



Photo is TK-290 K type.
Does not come with antenna.
Antenna is available as an option.

CONTENTS

GENERAL	2
SYSTEM SET-UP	2
OPERATING FEATURES	3
REALIGNMENT	10
CIRCUIT DESCRIPTION	16
SEMICONDUCTOR DATA	23
DESCRIPTION OF COMPONENTS	26
PARTS LIST	28
EXPLODED VIEW	34
PACKING	35
DISASSEMBLY FOR REPAIR	36
ADJUSTMENT	37
LEVEL DIAGRAM	48
PC BOARD VIEWS	
CONTROL UNIT (X53-3780-XX)	49
TX-RX UNIT (X57-5390-10)	53
SCHEMATIC DIAGRAM	59
BLOCK DIAGRAM	67
TERMINAL FUNCTION	69
KNB-17A (Ni-Cd BATTERY)	70
KMC-25/26 (SPEAKER MICROPHONE)	71
KSC-19 (CHARGER)	72
KSC-20 (RAPID CHARGER)	72
KPG-36 (PROGRAMMING INTERFACE CABLE)	72
KRA-14 (HELICAL ANTENNA)	72
SPECIFICATIONS	73

CAUTION

When using an external power connector,
please use with maximum final module protec-
tion of 10V

GENERAL / SYSTEM SET-UP

INTRODUCTION

SCOPE OF THIS MANUAL

This manual is intended for use by experienced technicians familiar with similar types of commercial grade communications equipment. It contains all required service information for the equipment and is current as of the publication data. Changes which may occur after publication are covered by either Service Bulletins or Manual Revisions. These are issued as required.

ORDERING REPLACEMENT PARTS

When ordering replacement parts or equipment information, the full part identification number should be included. This applies to all parts : components, kits, or chassis. If the part number is not known, include the chassis or kit number of which it is a part, and a sufficient description of the required component for proper identification.

PERSONNEL SAFETY

The following precautions are recommended for personnel safety :

- DO NOT transmit until all RF connectors are verified secure and any open connectors are properly terminated.
- SHUT OFF and DO NOT operate this equipment near electrical blasting caps or in an explosive atmosphere.
- This equipment should be serviced by a qualified technician only.

SERVICE

This radio is designed for easy servicing. Refer to the schematic diagrams, printed circuit board views, and alignment procedures contained within.

NOTE

WE CANNOT guarantee oscillator stability when using channel element manufactured by other than KENWOOD or its authorized agents.

FCC COMPLIANCE AND TYPE NUMBERS

Model	Type acceptance number	Frequency range	Compliance
TK-290	ALH21893110	136~174MHz	Parts 22,74,80,90

Model & destination	Unit		Frequency range	Remarks	Charger	Battery	Antenna	Keypad	
	X57-539X-XX	X53-378X-XX							
TK-290	K	0-10	0-10	136~174MHz	IF1 : 44.85MHz LOC : 45.305MHz	OP	OP	OP	-
	K2	0-10	0-11						

SYSTEM SET-UP

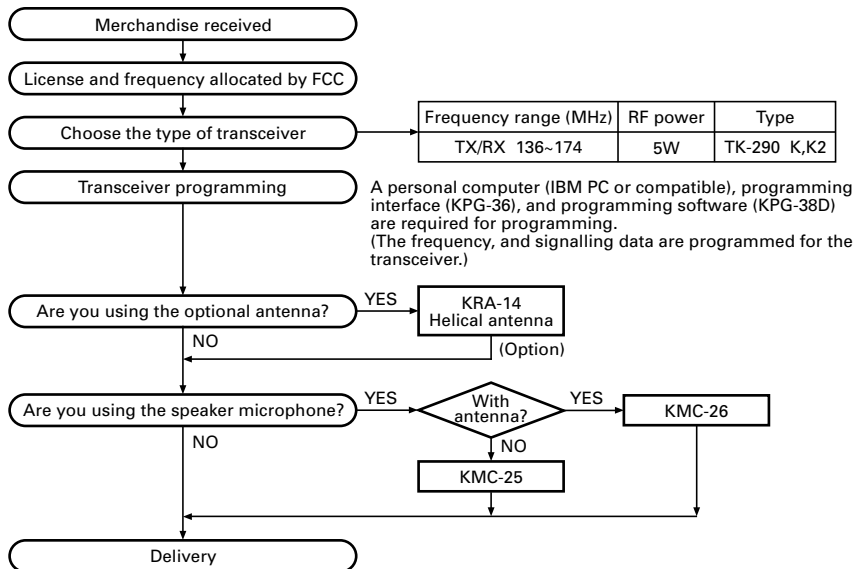

OPERATING FEATURES

1. Getting Acquainted

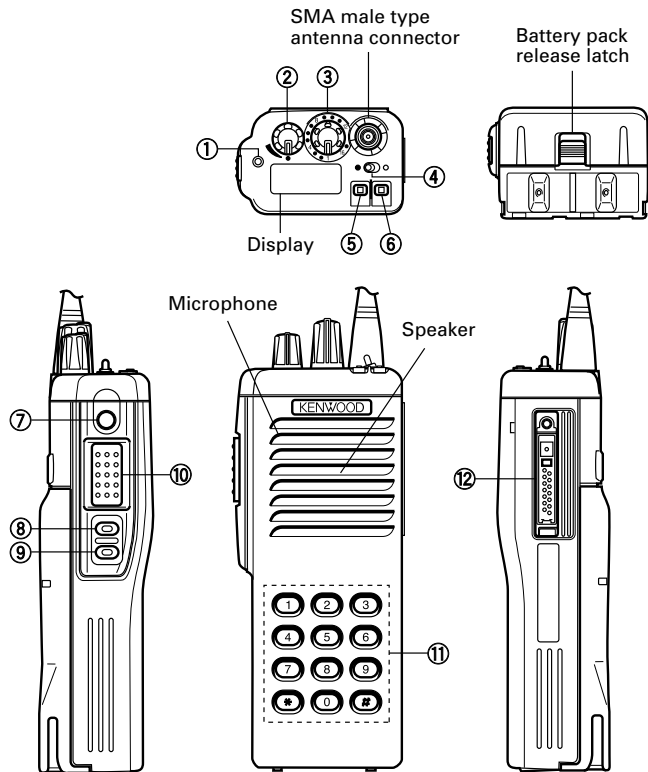

1-1. Key Descriptions

- ① **TX/Busy/Battery low indicator**
Lights red while transmitting. Lights green while receiving. Flashes red when the battery power is low while transmitting; replace or recharge the battery.
Note : This indicator can be disabled by your dealer.
- ② **Power switch/Volume control**
Turn clockwise to switch ON the transceiver. Turn counterclockwise, until a click sounds, to switch OFF the transceiver. Rotate to adjust the volume level.
- ③ **Selector**
Rotate this control to activate its programmable function (Page 8).
- ④ **Toggle switch**
Switch the toggle position to activate its programmable function (Page 8).
- ⑤ **Top 1**
⑥ **Top 2**
⑦ **Orange**
⑧ **Side 1**
⑨ **Side 2**
Press these PF (programmable function) keys to activate their programmable functions (Page 8)
- ⑩ **PTT (Push-To-Talk) switch**
Press this switch, then speak into the microphone to call a station.

- ⑪ **DTMF keypad (keypad models only)**
Press the keys on the telephone keypad to send DTMF tones.
- ⑫ **Universal connector**
Connect the external speaker/microphone (optional) here. Otherwise, keep the supplied cover in place.

1-2. Display

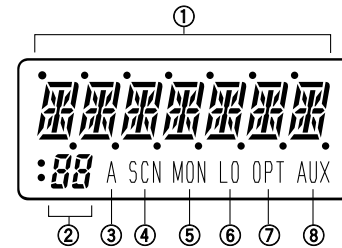

- ① **Alphanumeric display**
Displays the operating group or channel number, or the group or channel name. When making a DTMF or 2 Tone call, the display will alternate between CALL and the channel. Also displays various menu functions.
 - ② **7 Segment display**
Displays the operating group or channel number. Also displays tA (Talk Around), P1 (Priority1), P2 (Priority2), or HC (Home Channel); depending on the function being used.
 - ③ **A (Add) indicator**
Appears when a channel is added to the scanning sequence.
 - ④ **SCN (Scan) indicator**
Appears when Scan mode is active.
 - ⑤ **MON (Monitor) indicator**
Appears when the monitor function is active.
 - ⑥ **LO (Low) indicator**
Appears when low power is selected.
 - ⑦ **OPT indicator**
Appears when Operator Selectable Tone is enabled.
 - ⑧ **AUX (Auxiliary) indicator**
Appears when Aux is ON. Appears and blinks when the optional scrambler board is enabled.
- Note :** The alphanumeric and 7 segment displays can be inverted if a PF key or the toggle switch is programmed with Invert Display (Page 8).

OPERATING FEATURES

2. Scan Operating

2-1. Scan Types

• Single Group Scan

You can scan all valid (ADD) channels in the displayed group that can be selected with the group selector.

• Multiple Group Scan

You can scan all valid (ADD) channels in the all valid (ADD) group.

2-2. Scan Start Condition

One or more non-priority channels must be added to all channels that can be scanned. The transceiver must be in normal receive mode (PTT off).

When you activate the key or the toggle switch (to right position) programmed to the scan function, the scan starts. The scan icon "SCN" lights and "SCAN" or revert channel (programmable) is indicated on 7-digit alphanumeric display.

2-3. Scan Stop Condition

The scan stops temporarily if the following conditions are satisfied.

- 1) A carrier is detected, then signalling matches on channels for which receive the signalling is set by the programming software.
- 2) A carrier is detected on the channel for which receiving signalling is not set by the programming software or when the monitor (signalling cancel) function is activated.

2-4. Scan Channel Types

- 1) Priority channel 1 is the most important channel for the scan, and always detects a signal during scan and when the scan stops temporarily.
- 2) Priority channel 2 is the next important channel for the scan, and always detects a signal during scan and when the scan stops temporarily at a channel other than priority channel 1.
- 3) Non-priority channels detects a signal during scan. For the channels that can be selected with the group or channel selector when the scan does not occur, adds an indicator "A" lights.

2-5. Priority Channel Setting

Priority channels 1 or 2 can be set as follows with the programming software (KPG-38D).

- 1) Specify priority channels 1 or 2 as fixed priority channels.
- 2) Make selected channels, priority channels.
- 3) Operator delectable
Specify the initial channel before the operator changes it.

2-6. Scan Type According to the Priority Channel

- 1) When no priority channels are set : Only the non-priority channels are scanned.
If a non-priority channel stops temporarily, it stops until there is no signal on the channel.

- 2) When one priority channel is set : Either priority channel 1 or 2 is scanned.

If a non-priority channel stops temporarily, a priority channel signal is detected at certain intervals.

If a priority channel stops temporarily, it stops until there is no signal on the priority channel.

- 3) When two priority channels are set : The non-priority channel, priority channels 1 and 2 are scanned.

If a non-priority channel stops temporarily, priority channel 1 and 2 signals are detected at certain intervals.

If priority channel 2 stops temporarily, the priority channel 1 signal is detected at certain intervals.

If priority channel 1 stops temporarily, it stops until there is no signal on priority channel 1.

2-7. Revert Channel

The revert channel is used to transmit during scanning and set by the programming software (KPG-38D).

- 1) Priority 1

The transceiver reverts to the priority channel 1.

- 2) Priority 1 with talkback

The transceiver reverts to the priority channel 1.

If you press PTT during a resume timer (dropout delay time, TX dwell time) or calling, you can transmit on current channel to answer to the call however revert channel is set to priority channel 1.

After resume time, scan re-starts and transmission channel is return to priority channel 1.

- 3) Priority 2

The transceiver reverts to the priority channel 2.

- 4) Priority 2 with talkback

The transceiver reverts to the priority channel 2.

If you press PTT during resume timer (dropout delay time, TX dwell time) or calling, you can transmit on current channel to answer to the call however revert channel is set to priority channel 2.

After resume time, scan re-starts and transmission channel is return to priority channel 2.

- 5) Selected channel

The transceiver reverts to the channel before scanning or the channel that you changed during scan.

- 6) Last called channel

The transceiver reverts to the last called channel during the scan.

- 7) Last used channel

The transceiver reverts to the last used (transmitted) channel during scan. "Last used" revert channel includes talkback function.

- 8) Selected with talkback

The transceiver reverts to the channel before scanning or the channel that you changed during scan.

2-8. Scan End

When you reactivate the key or the toggle switch (to left position) programmed to the scan function during scan mode, the scan ends.

The scan icon "SCN" and "SCAN" or revert channel (programmable) display goes off.

OPERATING FEATURES

2-9. Temporarily Delete/Add

It is possible to delete or add channel temporarily during scan. When scan stops on unnecessary channel for example by interference of the other party, activate the delete/add function (for example press the key), then that channel is deleted temporarily and scan re-start immediately.

When you would like to add the deleted channel temporarily to scan sequence, select the desired (deleted) channel during scan, activate the delete/add function (for example press the key) before scan re-start.

That channel is added temporarily to scan sequence. The temporary deleted or added channels are returns to pre-set delete/add, when the transceiver exits from scan mode.

3. Optional Features

You can use these features using the programming software (KPG-38D).

3-1. Alphanumeric Display (Group/Channel Name)

The programming software (KPG-38D) enables you to set the alphanumeric display for group/channel name. The total text size of group and channel name are 7-digits.

For example, If you set 2-digits for group name, then you can use 5-digits for channel name. The characters can be used as shown in Figure 1.

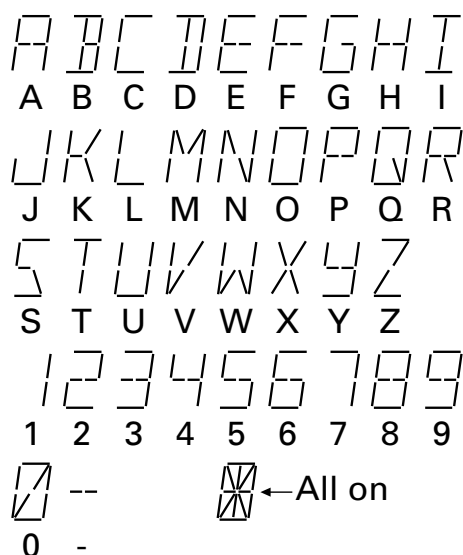

Fig. 1

3-2. Beep Tones

The beep tones (power on tone, control tone, warning tone, alert tone) are individually programmable to the fixed level 0 to 31 or follow the mechanical volume position.

3-3. Minimum Volume

The minimum volume is programmable (0 to 31). The transceiver remains the minimum volume level however the mechanical volume position is set to zero.

3-4. BCL (Busy Channel Lockout) Override

You can transmit in spite of Busy Channel Lockout situation. For example : To make an emergency voice call.

To transmit under busy channel lockout situation, press PTT once more within approx. 500ms after the PTT release.

3-5. Selective Call Alert LED

You can select whether or not the LED on the transceiver flashes in an orange color when Selective call was occurred.

3-6. Battery Warning

This transceiver has battery warning feature. If the low voltage is detected during transmission, the transceiver warns it by flashing red "LED".

Then more low voltage is detected during transmission, the transceiver stops transmission and warns it by flashing red "LED" and beep.

Please notice "standard" for the battery exchange, charging time by flashing red LED and beep.

3-7. Busy LED

You can program the enable or disable the busy "LED" function when a carrier is detected. "Disable" saves battery life.

3-8. TX LED

You can program the enable or disable the transmission "LED" function.

3-9. 2-Digit 7-Segment Display

You can use 2-digit 7-segment the display to display the channel number or group number. It is useful when the main (7-digit 13-segment) display indicates group or channel name.

3-10. Invert Display

Main (7-digit 13-segment) display and sub (2-digit 7-segment) display can be programmed to invert display.

It is easy to read the display when the operator suspended the transceiver on a waste belt. The operator also can change the display between normal and invert using key. Refer the invert display function of key function.

3-11. Emergency Channel Display

The transceiver can be programmed to display "EMERGENCY" channel name when it is in emergency mode.

If you set to "off" by KPG-38D the transceiver shows selected group/channel/status before entering to the emergency mode however the transceiver is in an emergency mode.

3-12. Clear to Transpond

The transceiver waits the transpond of 2-Tone/DTMF if channel is busy until channel open. This feature prevents the interference to other party.

3-13. External Speaker

It can be selected if the receive sound is made by SP-Mic SP or the main body SP at a SP-Mic mount.

OPERATING FEATURES

3-14. Mode (Enable/Disable)

The transceiver has many special modes mainly for maintenance.

- Self Programming mode
- Panel Test mode
- Clone mode
- Firmware Programming mode

It is possible to set enable/disable for each mode. We recommend to set these mode to Disable after set up to save contents.

3-15. ID

The transceiver is capable to have ID. The format is DTMF. The timing that the transceiver sends ID is programmable.

Connect ID : Connect ID is send on beginning of transmission.

Disconnect ID : Disconnect ID is send on end of transmission.

Both : Connect ID is send on beginning of transmission and disconnect ID is send on end of transmission.

Off : Sending ID function is disabled.

There is also "PTT ID" setting for each channel. Refer "PTT ID" of channel feature.

3-16. OST (Operator Selectable Tone)

The transceiver is capable to have "OST" function and 16 tone pair (QT/DQT) with max 7-digit name for each tone pair.

• "OST" Back Up

The transceiver is programmable the selected "OST" code is memorized or not. If you set to Disable (no memorized), the "OST" function always starts at "off".

• Direct "OST"

It is possible to call "OST" number directory using keypad. In this case, keypad is used for "OST", then "DTMF Auto PTT" "DTMF Auto Dial" functions by keypad are not usable.

3-17. Radio Password (Keypad Model Only)

The radio password prevent unauthorized users operation. Every time the power on, transceiver is locked and unusable until entering correct password.

Enter pre-programmed password by FPU and [#] key causes the transceiver unlocked.

3-18. Data Password (Keypad Model Only)

The data password prevents unauthorized reading of the programmed transceiver data by FPU. Enter pre-programmed password in FPU reading process. This password also protects the clone.

Enter pre-programmed password by FPU and [#] key to clone.

4. Group Features

You can use these features using the programming software (KPG-38D).

4-1. "TOT" (Time-Out Timer)

The transceiver has the "TOT". This parameter selects the period of time users can continuously transmit.

When the selected period passes, the transceiver generates an warning tone and stops the transmission.

4-2. "TOT" Pre-Alert

The transceiver has "TOT" pre-alert timer. This parameter selects the time at which the transceiver generates "TOT" pre-alert tone before "TOT" is expired.

"TOT" will be expired when the selected time passes from a TOT pre-alert tone.

4-3. "TOT" Re-Key Time

The transceiver has "TOT" re-key timer. This timer is the time you can not transmit after "TOT" exceeded. After "TOT" re-key time expired you can transmit again.

4-4. "TOT" Reset Time

The transceiver has "TOT" reset timer. This timer is the minimum wait time allowed during a transmission that will reset the "TOT" count.

"TOT" reset time causes the "TOT" to continue even after PTT is released unless the "TOT" reset timer has expired.

4-5. Group Delete/Add

The transceiver can set the delete/add in each group. If "Delete" is selected, the transceiver does not scan the deleted group in multi group scan.

4-6. Battery Save

This is the automatic battery saver during a standby mode operation. The receiver circuit is repeated on and off to conserve the battery life.

4-7. Signalling

Signalling "AND/OR" sets the audio unmute condition for any channel programmed with the option signalling (2-Tone/DTMF).

AND : "AND" requires both the valid option signalling and the programmed QT/DQT to be received for audio to unmute (and initiate an option signalling decode alert).

OR : "OR" requires either the valid option signalling or the programmed QT/DQT to be received for audio to unmute (an option signalling decode alert is only initiated if the proper option signalling is decoded).

OPERATING FEATURES

5. Channel Features

You can use these features using the programming software (KPG-38D).

5-1. Option Signalling

The transceiver is programmable to the option signalling (2-Tone decode program 1, 2-Tone decode program 2, 2-Tone decode program 3, DTMF decode) to each channel. It is useful to receive an individual call.

Receive format is selectable "AND" or "OR" with QT/DQT for each group. The radio response of option signalling is programmable "(Call) Alert tone" or "Transpond" for each option signalling (2-Tone decode program 1, 2-Tone decode program 2, 2-Tone decode program 3, DTMF).

5-2. PTT ID

PTT ID provides a DTMF ANI to be sent with every time PTT (connect ID at beginning of transmission, disconnect ID at end of transmission, or both).

You can program PTT ID "on" or "off" for each channel. The contents of ID are programmed for each transceiver.

5-3. Busy Channel Lockout

Transmission is inhibited when the channel is busy. It is able to set this feature "Yes" or "No" for each channel.

5-4. Beat Shift

This is the feature that the microprocessor shifts its system clock frequency slightly to prevent the receive interference. This transceiver can program this feature "Yes" or "No" for each channel.

5-5. TX Power

You can set the transmission power "High" or "Low" for each channel. The each power setting is tuned at factory.

However, you can re-tune the power, using PC Tuning Mode of KPG-38D.

5-6. Wide/Narrow

You can set the occupied band width mode "Wide" or "Narrow" for each channel. It is useful for the operator to use the transceiver on various sites.

5-7. Scan Delete/Add

Scanning "delete/add" is programmable for each channel. Set the currently selected channel required to include in the scan sequence to "add".

The operator can change the "delete/add" information using the key programmed to "delete/add" function.

6. Key Functions

You can use these features, using the programming software (KPG-38D). Selector function is selectable channel select or group select.

The functions for Toggle switch are listed page 8 (Fig. 2). Right position is active for programmed function on toggle switch except "group select".

The functions for the top key are listed page 8 (Fig.2). Hold action and shift action are programmable.

The functions for side key are listed page 8 (Fig.2). Hold action and shift action are programmable.

The functions for microphone key are listed page 8 (Fig.2). Hold action is programmable.

6-1. No Function

Sounds error operation beep, and no action will occur. Use this function when the transceiver is required to be more simple operated.

6-2. AUX.

This function can be programmed when the voice scrambler board is not installed.

If this key is pressed, "AUX" icon lights on the LCD and AUX port which is inside of the transceiver turns to the high level. If pressed again, the "AUX" icon goes off and the AUX ports turns to the lower level.

6-3. Channel Down

If this key is pressed once, the channel number decreases by one step. If this key holds down for 500ms (approximate), the channel number decreases continuously.

This key works as the squelch level adjuster in a squelch level adjust mode. This key works as the OST (operator selectable tone) number selector in the OST mode. This key works as the SCR (voice scrambler) code selector in the voice scrambler code select mode.

6-4. Channel Up

If this key is pressed once, the channel number increases by one step. If this key holds down for 500ms (approximate), channel number increases continuously.

This key works as the squelch level adjuster in squelch level adjust mode. This key works as the OST (operator selectable tone) number selector in the OST mode. This key works as the SCR (voice scrambler) code selector in the voice scrambler code select mode.

6-5. Channel Name

This key switches the LCD display between the group/channel number and the group/channel name.

6-6. Delete/Add

This key switches the currently displayed channel between "Delete" and "Add".

The "Add" channel contained in the scan sequence, and "Delete" channel is not contained. In the scan mode, this key switches the channel delete or add temporarily.

OPERATING FEATURES

Function Name	Selector ③	Toggle Switch ④	PF Keys ⑤⑥⑦ ⑧⑨	Speaker/ Microphone PF Keys
Aux ¹		✓	✓	✓
Channel Down			✓	✓
Channel Name			✓	✓
Channel Select	✓			
Channel Up			✓	✓
Delete/Add			✓	✓
Emergency Call ²			✓	✓
Group Down			✓	✓
Group Scan		✓		
Group Select	✓	✓		
Group Up			✓	✓
Home Channel			✓	✓
Invert Display		✓	✓	✓
Key Lock		✓	✓	✓
Lamp			✓	✓
Low Power		✓	✓	✓
Monitor		✓	✓	✓
Monitor Momentary			✓	✓
No Function		✓	✓	✓
Operator Selectable Tone			✓	✓
Operator Selectable Priority 1			✓	
Operator Selectable Priority 2			✓	
Scan		✓	✓	✓
Scrambler ³		✓	✓	✓
Shift		✓	✓	
SP Attenuation				✓
Squelch Level			✓	✓
Squelch OFF		✓	✓	✓
Squelch Momentary			✓	✓
Talk Around		✓	✓	✓

- 1 This function can be selected when the scrambler board has not been installed.
- 2 This function can be selected when the ANI board has been installed.
- 3 This function can be selected when the scrambler board has been installed.

Note : If "Shift" is programmed onto one of the PF keys or the toggle switch, the remaining PF keys can be programmed with two different functions. If "Shift" is programmed onto a PF key and the toggle switch, an error will occur and the function will not operate.

Fig. 2 Programmable functions

6-7. Group Down

If this key is pressed once, the group number decreases by one step. If this key holds down for 500ms (approximate), the group number decreases continuously.

This key works as the squelch level adjuster in squelch level adjust mode. This key works as the OST (operator selectable tone) number selector in the OST mode. This key works as the SCR (voice scrambler) code selector in the voice scrambler code select mode.

6-8. Group Up

If this key is pressed once, the group number increases by one step. If this key holds down for 500ms (approximate), the group number increases continuously.

This key works as the squelch level adjuster in the squelch level adjust mode. This key works as the OST (operator selectable tone) number selector in the OST mode. This key works as the SCR (voice scrambler) code selector in the voice scrambler code select mode.

6-9. Home Channel

Press this key once, the channel switches to the pre-programmed home channel. Press this key again, the channel goes back to the previous channel.

6-10. Invert Display

Press this key once, the displayed the group/channel number or group/channel name are inverted. Press this key again, the display returns to the normal.

For the operator who does not change the display and needs "Invert" only, refer "Invert Display" setting of optional feature.

6-11. Key Lock

Pressing this key causes the transceiver to accept an entry of only the [Shift], [KeyLock], [PTT], [Emergency] keys, [Selector switch], [Volume], [Toggle], [Lamp], [Moni], [Moni momentary], [SQ off] and [SQ momentary].

"Lock" is used to prevent users from unexceptable key press which might cause a transceiver malfunction. The display does not change while the key is being locked.

Switching the transceiver off and on or pressing Key Lock again cancels the key lock. Key locked transceiver can still receive. Pressing this key while scanning, keys are locked but a scanning continues.

6-12. Lamp

Press this key, the transceiver illuminates the display and keypad back lit approximate 5 seconds. Press this key again, the transceiver stops the illuminating.

Pressing any key except the LAMP key while the illuminated restarts the 5 second timer.

6-13. Low Power

Press this key, the transmission power of all channel changes to Low. Press this key again, the transmission power returns to programmed value.

OPERATING FEATURES

6-14. Monitor

Monitor the channel before a transmission.

Press this key once, "MON" appears and unmutes speaker if a carrier is present, regardless of the specified signalling (including option signalling). Press this key again, "MON" disappears and mutes speaker.

Press this key after the Option Signalling is matched, the Option Signaling is reset and monitor is activated. DBD (Dead Beat Disable) mode is not reset by this operation.

6-15. Monitor Momentary

While pressing this key, the monitor function (refer 6-14) is activated. Release this key, the monitor function is deactivated.

6-16. Operator Selectable Tone

This key switches the pre-set decode QT/DQT and encode QT/DQT to OST (Operator Selectable Tone) tone pair.

Press this key, the transceiver enters to OST select mode. In this mode, the display shows "OFF" and the operator can select one of the OST tone pair using the channel up/down key or the group up/down key. The display shows "TONE * * " and tone pair No. * * is selected.

Press OST key again, the transceiver exits from the OST select mode, and returns to the group/channel mode with "OPT" icon. "OPT" icon means that the OST tone pair is selected. OST tone pair number or OFF can be memorized for each channel.

16 kinds of tone pair for OST can be programmed by KPG-38D. OST is useful to access the repeater with same radio frequency and different tone (QT/DQT).

6-17. Operator Selectable P1

If priority channel 1 is set as "Fixed" and "None" in the scan information. The operator can select the priority channel 1, using this key (operator selectable fixed P1).

Press this key on normal channel, the channel becomes to priority channel 1. Previous priority channel 1 returns to the normal channel. Press this key on the priority channel 1, the priority 1 will be lost (no priority 1).

6-18. Operator Selectable P2

If priority channel 2 is set as "Fixed" and "None" in the scan information. The operator can select the priority channel 2, using this key (operator selectable fixed P2).

Press this key on the normal channel, the channel becomes to the priority channel 2. Previous priority channel 2 returns to the normal channel. Press this key on priority channel 2, the priority 2 will be lost (no priority 2).

6-19. Scan

Press this key starts scanning. Pressing this key stops scanning.

6-20. Shift

This key activates "Shift + [Key]" function. It is useful when the numbers or more of the functions are necessary.

6-21. Squelch Level

The preset squelch level is varied in user mode (0 to 15). Press the key programmed to "squelch level", the transceiver enters to "squelch level adjust mode".

The squelch level can be adjusted by group "up/down" function key or channel "up/down" function key. Press the key programmed to "squelch level" again, the adjusted level is memorized and returns to the normal user mode.

6-22. Squelch Momentary

While pressing this key, the transceiver unmutes speaker regardless of an existence of a carrier and "MON" appears and busy "LED" lights on.

Release this key, the transceiver mutes the speaker and "MON" disappears and busy "LED" lights off.

6-23. Squelch Off

Press this key, the transceiver unmutes speaker regardless of the existence of a carrier and "MON" appears and busy "LED" lights.

Press this key again, the transceiver mutes the speaker and "MON" disappears and busy "LED" lights off.

6-24. Talk Around

Press this key, the transceiver uses the receive frequency and the tone for transmission.

The operator can call the other party directory (without repeater). Press this key again, the talk around function goes off.

6-25. Emergency Call

Press this key, the transceiver enters to an emergency mode. In this mode, the channel is switched to the programmed emergency channel automatically and starts transmission with an emergency ID code which is programmed to ANI board.

The display depends on "Emergency Channel Display" setting.

6-26. SP Attenuation

Press this key once, the volume level of speaker-microphone is attenuated. Press this key again, the volume level of speaker-microphone returns to the previous level.

7. 2-Tone

Built-in 2-Tone decoder (decoder program 1, decoder program 2, decoder program 3) is available for option signalling. It is possible to use individual call or group call.

8. DTMF

Built-in DTMF encoder is available for dialing (Manual dial, Auto-dial (9 memory), Re-dial (1 memory)) (Keypad model only). Built-in DTMF decoder is available for option signalling.

It is possible to use individual call, group call, DBD (Dead Beat Disable).

OPERATING FEATURES / REALIGNMENT

9. Data Programming (PC Mode)

9-1. Preparation and Connection

TK-290 transceiver is programmed by using a personal computer, programming interface cable KPG-36, and programming software KPG-38D.

The programming software can be used with an IBM-PC or compatible machine. Figure 3 shows the setup for programming.

9-2. Programming Interface Cable KPG-36 Description

The KPG-36 is required to interface TK-290 to the computer. It has a circuit in its D-sub 25pin connector case that converts RS-232C logic level to TTL level.

KPG-36 is used to connect between TK-290 universal connector and RS-232C serial port of computer.

9-3. Programming Software KPG-38D Description

KPG-38D is the programming software for TK-290 supplied on a 3.5" floppy disk. This software runs under MS-DOS version 3.1 or later on an IBM-PC/XT, AT, or PS2 or compatible machine.

The data can be input to or read from TK-290 and edited on the screen. The programmed or edited data can be printed out. It is also possible to tune the transceiver.

We recommend that install KPG-38D for example to harddisk first then use it.

KPG-38D instruction manual part No. : B62-0814-XX.

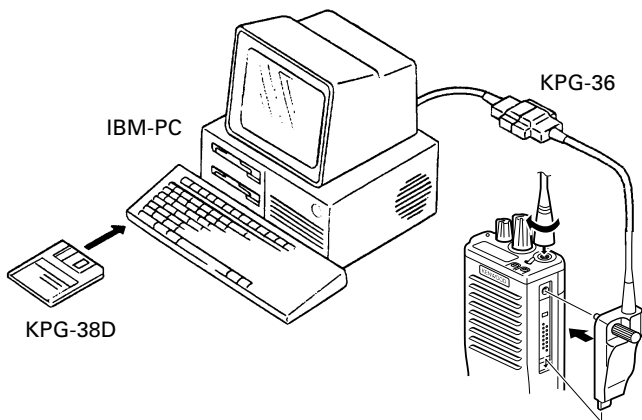
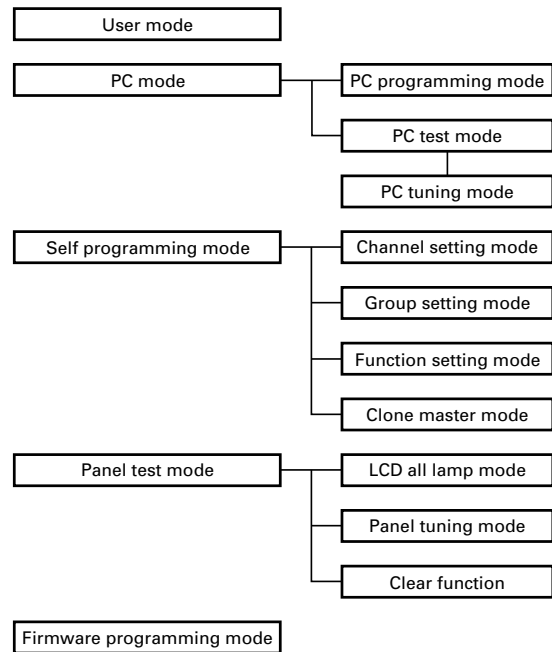

Fig. 3

REALIGNMENT

1. Mode



Mode	Function
User mode	Customer use this mode
PC mode	Communication between the radio and PC (IBM compatible). It requires the KPG-38D
PC programming mode	Frequency, signalling and features write to the radio and read from the radio.
PC test mode	Check the radio using the PC. This feature is included in the FPU.
Self programming mode	Frequency, signalling and features write to the radio.
Panel test mode (Refer to Adjustment)	Dealer use to check the fundamental characteristics.
Firmware programming mode	Re-write the firmware of the flash ROM.

2. How to Enter Each Mode

Mode	Operation
User mode	Power on
PC mode	Power on begins the USER MODE.
Self programming mode	Hold down the [Side 1] key and the [Side 2] key, turn the radio power on.
Panel test mode	Hold down the [Side 2] key and [PTT], turn the radio power on, and release [PTT] first.
Firmware programming mode	Held down the [Side 2] key and [PTT], turn the radio power on, and release [Side 2] key first.

REALIGNMENT

3. Self Programming

Write mode for frequency data and signalling etc. Mainly used by the person maintaining the user equipment.

3-1. Enter to the self programming mode

Turn the power switch on, with the lead wire with plug PF (8 pin) shorted to the E (10 pin) lead (Figure 4), or delete R466 (SELF, Figure 5) in the TX-RX unit and turn the power switch on while pressing the [Side 1] and [Side 2] keys.

Note :

This mode (self programming mode) cannot be set when it has been disabled with the FPU.

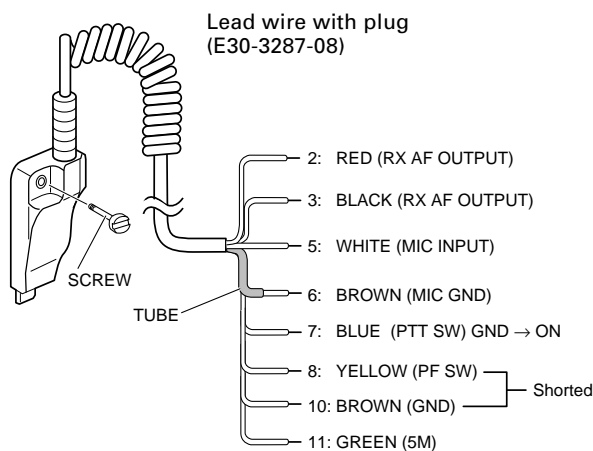

Fig. 4

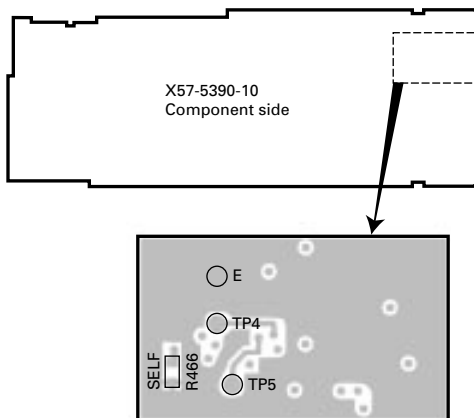

Fig. 5

When enter the self programming mode, "FUNC" appears after "SEL" is displayed for half a second.

Selecting any of Channel setting, Group setting, Function setting, or Clone master with the [Top 1] [Top 2] keys and then pressing [PTT] sets the Setting mode for that time.

Key operations in Self programming mode are as follows.

- [Selector switch] : Not used
- [PTT] : Functions as a RUN or Execute key
- [Top 1] : Use as a Down key
- [Top 2] : Use as an Up key
- [Side 1] : Use for select channel steps in Channel setting mode, or switching for QT/DQT.
- [Side 2] : Use as a cancel key
- [Orange] : Add or delete frequencies in Channel setting mode
- [Toggle] : Flipping this to the right while in Channel setting mode, shifts to MHz steps.

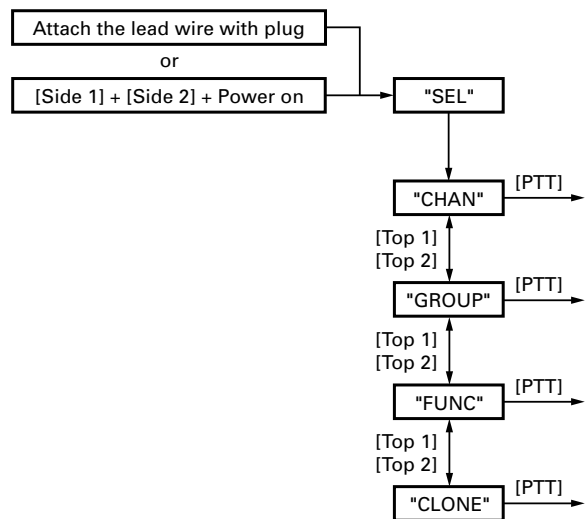

REALIGNMENT

3-2. Channel Setting Mode

Set data for each channel while in this mode. After first entering Self programming mode, select the "CHAN" display with [Top 1] [Top 2] and press [PTT] to set Channel Setting mode. Once in Channel Setting mode, select the group that needs setting with the [Top 1] [Top 2] keys and press [PTT]. Next select the channel for setting with the [Top 1] [Top 2] keys and press [PTT]. The setting items and setting data will then appear so reset the data with the [Top 1] [Top 2] keys and press [PTT]. When finished, the display shifts to the next setting item. After finished setting all items press [PTT] to return to Group selection. Changes in the frequency CH steps and the QT/DQT steps can be made in [Side 1].

No.	Function name	Display	Remarks
	Select Group/Channel	1.-1 during group selection 1-1. during channel selection	1-160~160-1
1	RX frequency	R150.0125	Receive frequency (Dot on right edge is lit up during 6.25kHz steps)
2	RX signalling	RX 023N	Receive QT/DQT (Dot on right edge is lit up during 1 step changes)
3	TX frequency	T150.0125	Transmit frequency (Dot on right edge is lit up during 6.25kHz steps)
4	TX signalling	TX 250.3	Transmit QT/DQT (Dot on right edge is lit up during 1 step changes)
5	Option signalling	2ToneA	OFF, DTMF, 2ToneA, 2ToneB, 2ToneC
6	DEL/ADD	D/A ADD	Delete, Add
7	Wide/Narrow	WIDE	Wide. Narrow
8	PTT ID	ID OFF	OFF, ON
9	TX power	POW HI	High, Low
10	Busy channel lockout	BCL OFF	OFF, ON
11	Beat shift	SFT OFF	OFF, ON

• Operation

1. Select the setting value with the [Top 1] [Top 2] keys.
2. Press the [PTT] and the selected value is backed up and operation shifts to the next item for setting.
3. Press [Side 2] on the Group selection screen in order to return to Self programming mode.

• Note

1. Different sample displays are shown.
2. Setting item No.s are displayed with a 7-segment 2-digit figure on the LCD.
3. Self programming mode cannot be set when set to Disaable with the FPU.
4. A red LED lights up during TX frequency and TX signalling.
5. Press [Orange] on the TX, RX frequencies setting screen in order to clear in the channel frequencies data.
6. Press [Orange] on the signalling setting screen in order to change or off the signalling function.
7. Flipping [Toggle] to the right during setting of RX, TX frequencies and performing Up/Down operation allows frequencies to be changed in MHz steps.
8. The RX and TX frequencies can be entered with the number pad keys.

• Flow Chart

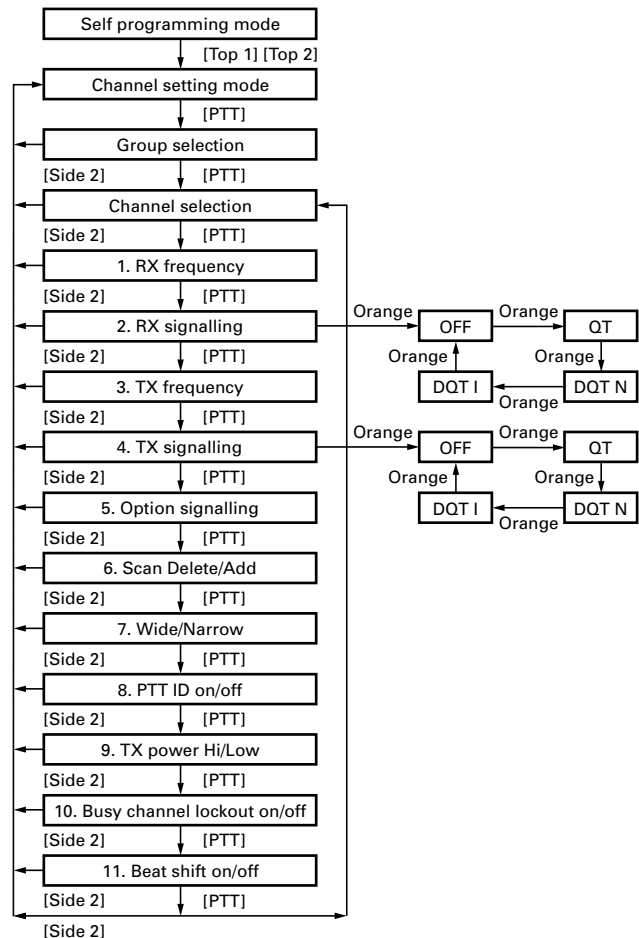

REALIGNMENT

3-3. Group Setting Mode

Set data for each Group while in this mode. After first entering Self programming mode, select the "GROUP" display with [Top 1] [Top 2] and press [PTT] to set Group Setting mode. Once in Group Setting mode, select the group that needs setting with the [Top 1] [Top 2] keys and press [PTT]. Next select the channel for setting with the [Top 1] [Top 2] keys and press [PTT]. The setting items and setting data will then appear so reset the data with the [Top 1] [Top 2] keys and press [PTT]. When finished, the display shifts to the next setting item. After finished setting all items press [PTT] to return to next Group selection.

No.	Function name	Display	Remarks
	Select Group	GRP 1	1~160
1	Battery save	BATT L	OFF, Short, Mid, Long
2	Time out timer	TOT 60	OFF, 30s~300s (30s step)
3	TOT pre alert	TOT.P 10	OFF, 1s~10s (1s step)
4	TOT rekey time	TOT.K 2	OFF, 1s~60s (1s setp)
5	TOT reset time	TOT.S 2	OFF, 1s~15s (1s step)
6	Group Delete/Add	D/A ADD	Delete, Add
7	Signalling	SIG AND	AND, OR

• Operation

1. Select the setting value with the [Top 1] [Top 2] keys.
2. Press the [PTT] and the selected value is backed up and operation shifts to the next item for setting.
3. Press [Side 2] on the Group selection screen in order to return to the Self programming mode initial display.

• Note

1. Different sample displays are shown.
2. Setting item No.s are displayed with a 7-segment 2-digit figure on the LCD.
3. Self programming mode cannot be set when set to Disable with the FPU.

• Flow Chart

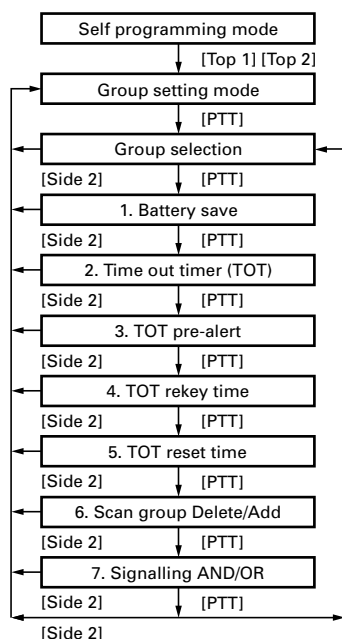

3-4. Function Setting Mode

This mode allows making function settings for the transceiver. After first entering Self programming mode, select "FUNC" display with [Top 1] [Top 2] and then press [PTT] to set this mode. Function setting items are listed below.

No.	Function name	Display	Remarks
1	Power on tone	POW.T 15 (or C)	Continuas, 0~31
2	Control tone	CON.T 15 (or C)	Continuas, 0~31
3	Warning tone	WAR.T 15 (or C)	Continuas, 0~31
4	Alert tone	ALR.T 15 (or C)	Continuas, 0~31
5	Minimum volume	MIN.V 8	0~31
6	Battery warning	BATT ON	Disable, Enable
7	Busy LED	B.LED ON	OFF, ON
8	TX LED	T.LED ON	OFF, ON
9	Invert Display	LCD ON	Disabel, Enable
10	Priority 1	P1 NONE	None, Selected, Fixed
11	Priority 1 group	1.-1	1-1~10-16
12	Priority 1 channel	1-1.	(Priority 1= In fixed)
13	Priority 2	P2 NONE	None, Selected, Fixed
14	Priority 2 group	1.-1	1-1~10-16
15	Priority 2 channel	1-1.	(Priority 2= In fixed)
16	Revert channel	REVT 1	1~8 1 : Selected 2 : Last called 3 : Last used 4 : Sel+Talk back 5 : Priority 1 6 : Priority 1+Talk back 7 : Priority 2 8 : Priority 2+Talk back
17	Squelch level	SQ.LV 15	0~15

• Operation

1. Select the setting value with the [Top 1] [Top 2] keys.
2. Press the [PTT] and the selected value is backed up and operation shifts to the next item for setting.
3. Press [Side 2] on the Group selection screen in order to return to the Self programming mode initial display.

• Note

1. Different sample displays are shown.
2. Setting item No.s are displayed with a 7-segment 2-digit figure on the LCD.
3. Self programming mode cannot be set when set to Disable with the FPU.

REALIGNMENT

• Flow Chart

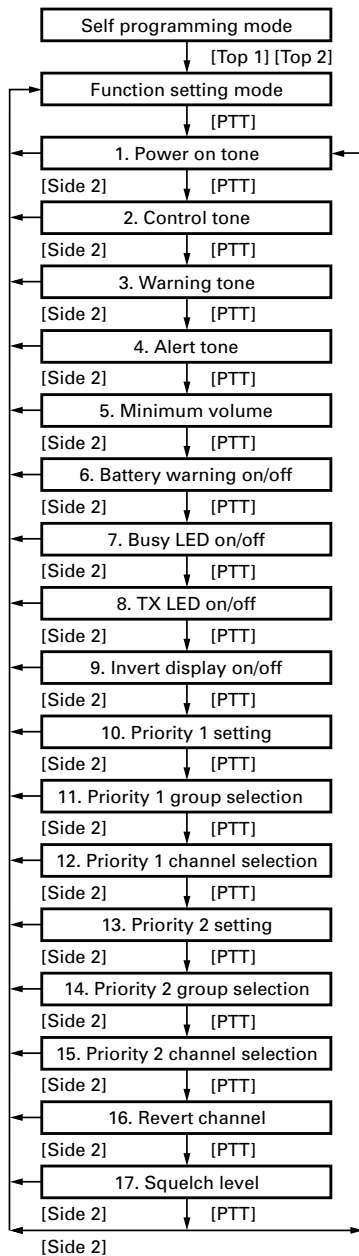

3-5. Clone Mode

1. Connect the cloning interface cable between the master side transceiver (source) and slave side transceiver (clone) as shown in the figure.

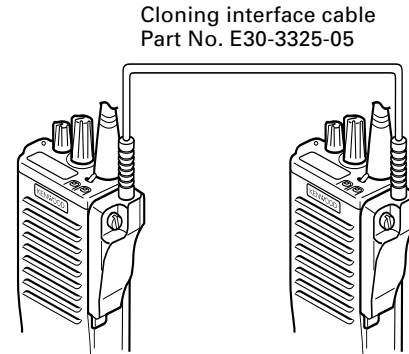

2. Set the master side transceiver to Self programming mode, and the transceiver display to "CLONE" with the [Top 1] key or [Top 2] key and press [PTT].

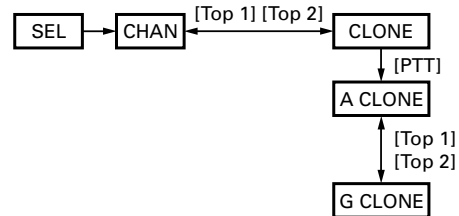

3. Set the power switch on the slave side transceiver to ON.
4. The red LED on the master side transceiver flashes when cloning starts and an "END" message appears when cloning ends.
5. The green LED on the slave side transceiver flashes.
6. When a problem occurs during cloning, an "ERROR" message appears on the master side transceiver.
7. Pressing the [Side 2] key sets clone mode.

Note :

The master transceiver copies only to type matched slave.

• All Clone

1. Press [PTT] on the master side transceiver to start cloning of all data except for the transceiver model type and alignment data.

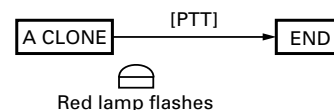

REALIGNMENT

• Group Clone

- To clone the transceiver group data and channel data within the group, as well as group alphanumeric data, use the [Top 1] key or [Top 2] key to switch the display on the master side transceiver from "A CLONE" to "G CLONE".

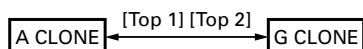

- Press [PTT] to show the group cloning selection.
- Select the group with the [Top 1] or [Top 2] keys.
- Press [PTT] to show the slave side group cloning selection.
- Select the group with the [Top 1] or [Top 2] keys.

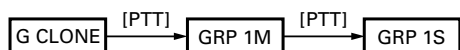

- Press the master side [PTT] to start cloning.

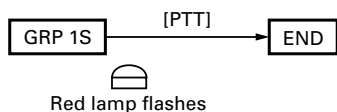

• Flow Chart

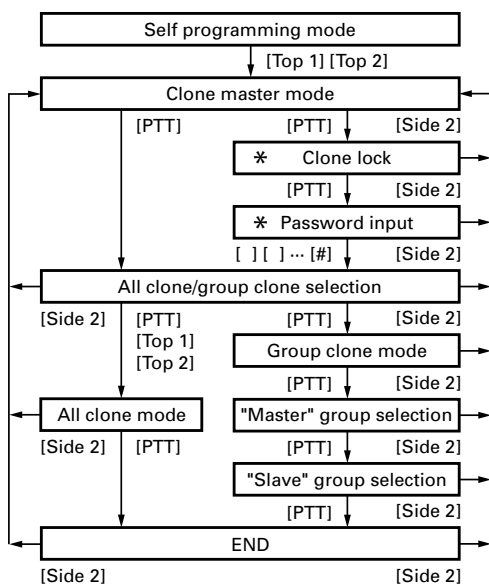

* Only the keypad model and set to password with the FPU.

4. Firmware Programming Mode

4-1. Preface

Flash memory is mounted on the TK-290. This allows the TK-290 to be upgraded when new features are released in the future. (For details on how to obtain the firmware, contact Customer Service.)

4-2. Connection Procedure

Connect the TK-290 to the personal computer (IBM PC or compatible) with the interface cable (KPG-36). (Connection is the same as in the PC Mode.)

4-3. Programming

- Start up the programming software (KPG-38D), select "firmware program" in the "Program" item, and press the Return key on the personal computer. This starts up the firmware programmer.
- The top screen is displayed. Press any key to advance to the next screen.
- Set the communications speed (normally, 38400 bps) and communications port in the Setup item.
- Set the firmware to be updated by File select (=F1).
- Held down the [Side 2] and [PTT]. Turn the TK-290 power on, and release [Side 2] first. Until the display change to "PROGRAM"
- Check the connection between the TK-290 and the personal computer, and make sure that the TK-290 is in the Program mode.
- Press F10 on the personal computer. A window opens on the display to indicate progress of writing. When the TK-290 starts to receive data, "PG" is appeared on 2 digit sub display.
- If writing ends successfully, the red LED on the TK-290 lights and the checksum is displayed.
- If you want to continue programming other TK-290s, repeat steps 5 to 8.

Notes :

- To start the Firmware Programmer from KPG-38D, the Fpro path must be set up by KPG-38D setup.
- This mode cannot be entered if the Main Program mode is set to Disable in the Programming software (KPG-38D).

4-4. Function

- If you press the [Top 2] switch while "PROGRAM" is displayed, the checksum is displayed. If you press the [Top 1] switch while the checksum is displayed, "PROGRAM" is redisplayed.
- If you press the [Top 1] switch while "PROGRAM" is displayed, 1 dot light ("M.") to indicate that the write speed is low-speed (19200 bps). If you press the [Top 1] switch again while low-speed (19200 bps), 2 dot lights ("M.") to indicate, and the write speed becomes the high-speed mode (38400 bps).

Note :

Normally, write in the high-speed mode.

5. Panel Test Mode

Setting method refer to ADJUSTMENT.

CIRCUIT DESCRIPTION

1. Overview

The KENWOOD model TK-290 is a VHF/FM hand-held transceiver designed to operate in the frequency range of 136 to 174MHz, the unit consists of a receiver, a transmitter, a phase-locked loop (PLL) frequency synthesizer, power supply circuits, a control unit.

2. Circuit Configuration by Frequency

The receiver is a double-conversion superheterodyne with a first intermediate frequency (IF) of 44.85MHz and a second IF of 455kHz. Incoming signals from the antenna are mixed with the local signal from the PLL to produce the first IF of 44.85MHz.

This is then mixed with the 45.305MHz second local oscillator output to produce the 455kHz second IF. This is detected to give the demodulated signal.

The transmit signal frequency is generated by the PLL VCO, and modulated by the signal from the microphone. It is then amplified and sent to the antenna.

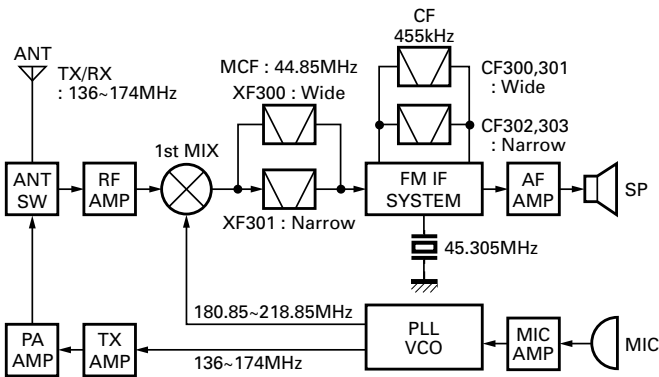

Fig. 1 Frequency configuration

3. Receiver System

3-1. Front-end RF amplifier

The signal are then passed through an antenna matching coil, where the high-frequency components are amplified by a GaAs FET (Q200). The signals are then fed into band-pass filter that uses varactor diode tuning to reject unwanted signal components, and is fed to the 1st mixer.

3-2. First mixer

The 1st mixer uses the GaAs IC (IC200). The 1st mixer mixes the signal with the 1st local oscillator frequency from the VCO, and converts it to the 1st IF (44.85MHz).

The signal then passes through monolithic crystal filter (XF300 ; Wide, XF301 ; Narrow) to remove unnecessary nearby frequency components. The signal from the MCF is used as the 1st IF signal.

3-3. IF amplifier

The 1st IF signal is amplified (Q302) and fed into IC300 in the FM IF IC. The IF signal is then mixed with the 2nd local oscillator frequency of 45.305MHz to generate the 2nd IF of 455kHz. The 455kHz signal is then passed through a ceramic filter (CF300, CF301 ; Wide, CF302, CF303 ; Narrow) and fed back into IC300 for additional amplification.

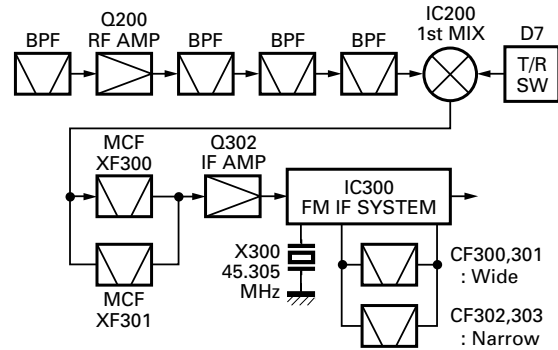

Fig. 2 Receiver section

Item	Rating
Nominal center frequency	44.85MHz
Pass band width	±5~7kHz or more at 3dB
Attenuation band width	±25kHz or less at 3dB
Ripple	1.0dB or less
Insertion loss	4dB or less
Guaranteed attenuation	80dB or more at $f_0 \pm 910\text{kHz}$ 40dB or more within $f_0 \pm 1\text{MHz}$
Terminating impedance	350 / 4.5pF

Table 1 Crystal filter XF300 (L71-0523-05) : Wide

Item	Rating
Nominal center frequency	44.85MHz
Pass band width	±3.75kHz or more at 3dB
Attenuation band width	±12.5kHz or less at 25dB
Ripple	1.0dB or less
Insertion loss	4dB or less
Guaranteed attenuation	80dB or more at $f_0 \pm 910\text{kHz}$ 40dB or more within $f_0 \pm 1\text{MHz}$
Terminating impedance	350 / 4.5pF

Table 2 Crystal filter XF301 (L71-0502-05) : Narrow

CIRCUIT DESCRIPTION

3-4. Wide/Narrow changeover circuit

Narrow and Wide settings can be made for each channel by switching the MCF; XF300 (Wide), XF301 (Narrow) with the ceramic filters CF300, CF301 (Wide), CF302, CF303 (Narrow).

The WIDE (high level) and NARROW (low level) data is output from IC400 (I/O port expansion) pin 4.

When a WIDE (high level) data is received, Q300, Q303 turn off and Q301, Q304 turn on. When a NARROW (low level) data is received, Q300, Q303 turn on and Q301, Q304 turn off. D300, D301 switch to MCF or D302, D303 are switched to ceramic filters when a high/low level data is received.

Q305 turns on/off with the Wide/Narrow data and the IC300 detector output level is changed to maintain a constant output level during wide or narrow signals.

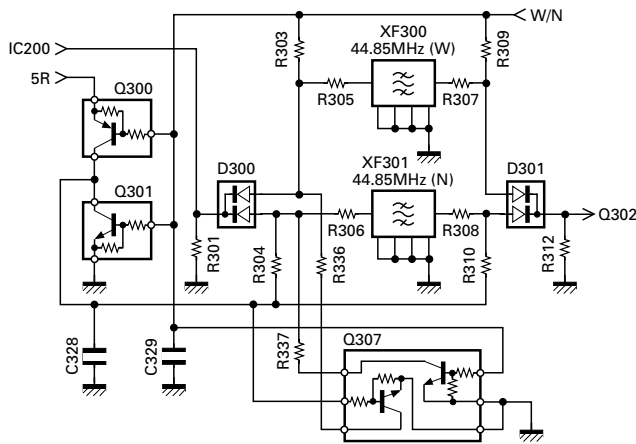

Fig. 3 Wide/Narrow changeover circuit

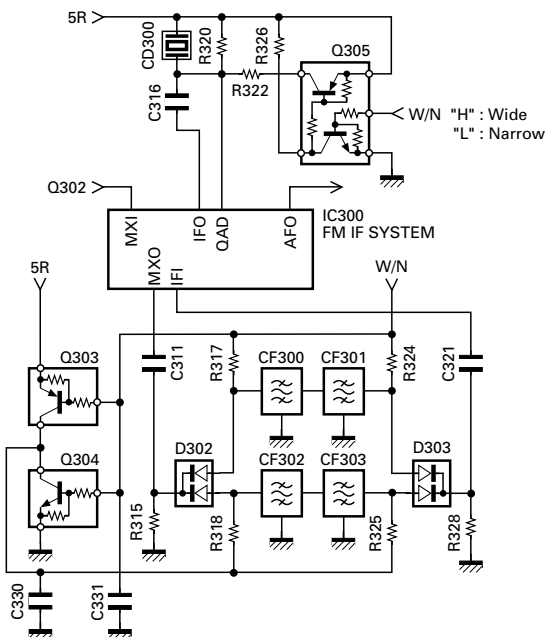

Fig. 4 Wide/Narrow changeover circuit

3-5. Audio amplifier circuit

• TX-RX unit

The demodulated signal from IC300 goes through IC301, and is amplified by IC601 (2/2), high-pass filtered, low-pass filtered, high-pass filtered, band-eliminate filtered, and deemphasized by IC607.

The signal then goes through an electronic volume control (IC603), an AF amplifier IC604 (2/2), and an AF switch (Q8 is on and Q7 is off of the control unit), and is routed to audio power amplifier (IC1 of the control unit), where it is amplified and output to the internal speaker.

• Control unit

The audio mute signal (AMP SW) from the microprocessor becomes Low in the standby and Q5, Q6 which are power supply circuit for IC1 turn off. When the audio is output, AMP SW becomes High to turn Q5, Q6 on, and voltage is supplied to power terminal VP of IC1.

Speaker switching is done from IC403 (TX-RX unit) by INT AFC or EXT AFC. First, the logic level at the speakers switching terminal (SSW) on the universal connector is input to the microprocessor (IC406 TX-RX unit). The microprocessor then outputs data to IC403 based on this input.

When there is no SP-MIC installed, this logic level is high. When the INT AFC is high, the EXT AFC goes low, so the AF signal is only input to the amplifier for the internal speaker (INT SP) of IC1. However, when a SP-MIC has been installed, this logic level is low, so the INT AFC goes low and the EXT AFC goes high. So that the AF signal is input only to amplifier for the external speaker (EXT SP) of IC1.

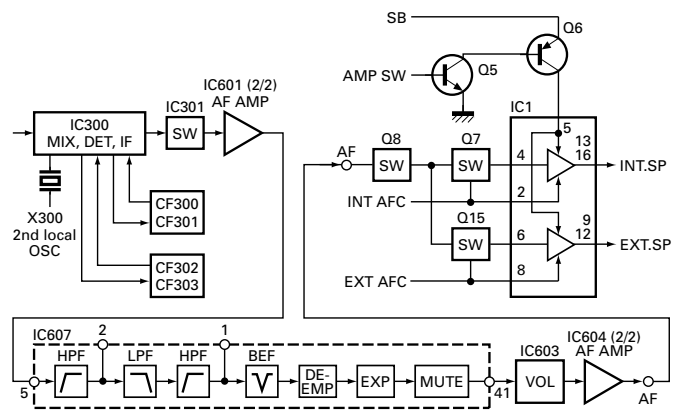

Fig. 5 Audio amplifier circuit

3-6. Squelch circuit

The output signal from the squelch circuit, which consists of IC605 (2/2) and Q600, is applied to the microprocessor. The microprocessor passes information to the shift register (IC403) and it controls the mute control lines (AMP SW, INT AFC, and EXT AFC) according to the input signal (noise pulse) and the microprocessor task condition.

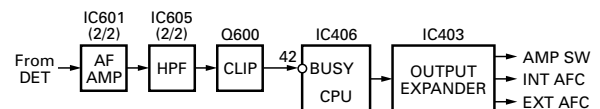

Fig. 6 Squelch circuit

CIRCUIT DESCRIPTION

4. Transmitter System

4-1. Microphone amplifier

The signal from IC3 (control unit) goes through the mute switch (Q403).

When the SP-MIC is not attached, the microphone switching terminal (MSW) on the universal connector becomes High, and mute switch (Q403) is turned on. When the SP-MIC is attached, MSW is connected to GND at inside of SP-MIC. For this reason, Q403 is turned off, the internal microphone is muted, and only the input of the external microphone is supplied to the microphone amplifier of the TX-RX unit.

The signal from microphone passes through the limiter circuit in D601, and through the high-pass filter, the ALC circuit, the low-pass filter, the high-pass filter, and pre-emphasis/IDC circuit in IC607. When encoding DTMF, mute switch (Q601) is turned off for muting the microphone input signal.

The signal passes through the D/A converter (IC603) for the maximum deviation adjustment, and enters the summing amplifier consisting of IC605 (1/2), and is mixed with the low speed data from the CPU (IC406).

The output signal from the summing amplifier goes to the VCO modulation input.

The other output signal from the summing amplifier passes through the D/A converter (IC603) again for the BAL adjustment, and the buffer amplifier (IC604 1/2), and goes to the VCXO modulation input.

4-2. Noise cancelling microphone circuit

The two signals from INT MIC (Main & Sub) are input to the positive (+) input (Sub) and to the negative (-) input (Main) of the IC3. If the same signal is input to both Main and Sub, the Main signal is canceled at the output of IC3 (pin 7). In other words, noise from nearby sources not directly connected to the transceiver enters the Main and Sub inputs at the same signal and is therefore canceled out.

When a signal is only input to Main and there is no signal at Sub, the Main signal is output as is, from IC3 (pin 7). In other words, only the voice audio of the operator in extremely close proximity to the Main MIC is input to Main so that the signal is output as is from IC3 (pin 7). Also, when the "N/C" switch is set to "L", transistor Q14 turns off so Sub microphone turns off and operation is the same as above.

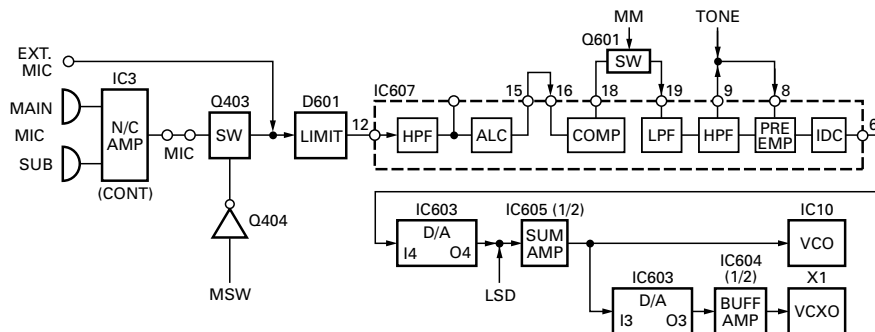

Fig. 7 Microphoen circuit

4-3. Drive and Final amplifier

The signal from the T/R switch (D7 is on) is amplified by the pre-drive (Q6) and drive amplifier (Q8) to 20mW. The output of the drive amplifier is amplified by the RF power amplifier (IC501) to 5W (1W when the power is low).

The RF power amplifier consists of two stages MOS FET transistor. The output of the RF power amplifier is then passed through the Transmit-Receive (TX-RX) antenna switching (D10 is on) and the harmonic filter (LPF) and the Internal-External (INT-EXT) antennal switching (in the universal connector) and applied to the antenna terminal.

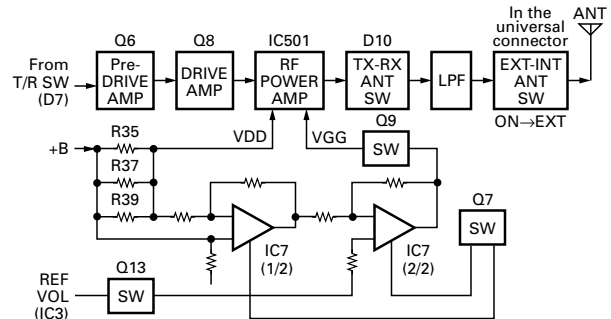

Fig. 8 Drive and final amplifier and APC circuits

4-4. Internal-External (INT-EXT) antenna switching

The INT-EXT antenna switch housed inside the universal connector only switches to the EXT ANT side when an antenna speaker-microphone has been installed.

This INT-EXT antenna switch works mechanically and switches based on the operation shown in Figure 9.

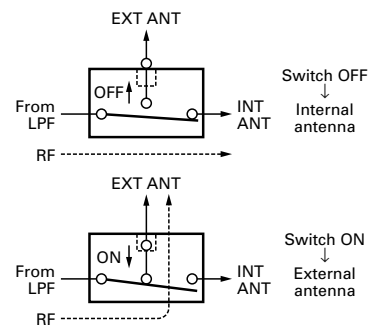

Fig. 9 Internal-External antenna switching

CIRCUIT DESCRIPTION

4-5. APC circuit

The APC circuit always monitors the current flowing through the RF power amplifier (IC501) and keeps a constant current. The voltage drop at R35, R37, and R39 is caused by the current flowing through the RF power amplifier and this voltage is applied to the differential amplifier (IC7 1/2).

IC7 (2/2) compares the output voltage of IC7 (1/2) with the reference voltage from IC3, and the output of IC7 (2/2) controls the VGG of the RF power amplifier to make the both voltages to same voltage.

The change of power high/low is carried out by the change of the reference voltage. Q7, Q9, and Q13 are turned on in transmit and the APC circuit is active. (See Figure 8)

5. PLL Frequency Synthesizer

The frequency synthesizer consists of the VCXO (X1), VCO (IC10), PLL IC (IC5) and buffer amplifiers.

The VCXO generates 16.8MHz. The frequency stability is within ± 2.0 ppm (temperature range of -30 to $+60^\circ\text{C}$). The frequency tuning and modulation of the VCXO are done to apply a voltage to pin 1 of the VCXO. The output of the VCXO is applied to pin 8 of the PLL IC.

The VCO of TK-290 covers the 38MHz spread, setting frequencies in r1, r2 (receive) and t1, t2 (transmit) with a bias voltage applied to the $-V$ terminal of the VCO. A zero (0) volt bias is applied at frequencies lower than r1, t1. Frequencies r1, t1 through r2, t2 are biased with -3 volts. Frequencies higher than r2, t2 are biased with -6 volts, and at 174MHz tp 178MHz are biased with -9 volts.

The relation of VCO frequency versus PLL lock voltage is shown in Figure 11.

The output of the VCO is amplified by the buffer amplifier (Q3) and routed to the pin 5 of the PLL IC. Also the output of the VCO is amplified by the buffer amplifier (Q5) and routed to the next stage according to T/R switch (D7).

The PLL IC consists of a prescaler, fractional divider, reference divider, phase comparator, charge pump. This PLL IC is fractional-N type synthesizer and performs is the 40 or 50kHz reference signal which is eighth of the channel step (5, 6.25 or 7.5kHz). The input signal from the pins 1 and 5 of the PLL IC is divided down to the 40 or 50kHz and compared at phase comparator. The pulsed output signal of the phase comparator is applied to the charge pump and transformed into DC signal in the loop filter (LPF). The DC signal is applied to the pin 4 of the VCO and locked to keep the VCO frequency constant.

PLL data is output from DT (pin21), CLK (pin 22) and LE (pin 20) of the microprocessor (IC406). The data are input to the PLL IC when the channel is changed or when transmission is changed to reception and vice versa. A PLL lock condition is always monitored by the pin 28 (UL) of the microprocessor. When the PLL is unlocked, the UL goes low.

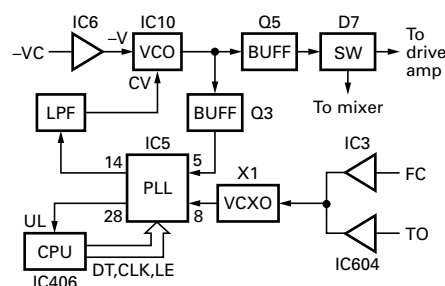

Fig. 10 PLL block diagram

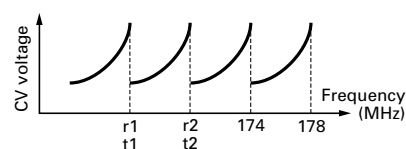

Fig. 11 CV voltage vs frequency

6. Power Supply Circuit

Battery +B is supplied via a 3A fuse from the battery terminal connected to the TX-RX unit. After passing through the power switch power supply (SB) is applied to the two AVR ICs, and AVR circuit.

IC401 supplies 5V (5CM) to the control circuit. IC402 supplies 5V (5M) to the common circuit.

AVR circuit (Q400, Q402, Q405, Q406) supplies voltage to the TX circuit and the RX circuit. 5C is common 5V and output when SAVE is not set at off. 5R is 5V for reception and output during reception. 5T is 5V for transmission and output during transmission.

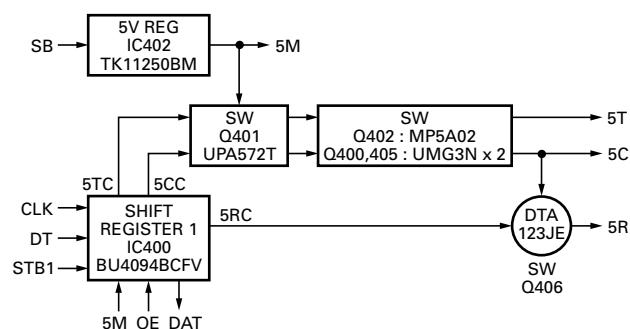

Fig. 12 Power supply circuit

CIRCUIT DESCRIPTION

7. Control Circuit

The control unit consists of microprocessor IC406 and its peripheral circuits. It controls the TX-RX unit and transfers data to and from the control unit. The CPU (IC406) mainly performs the following :

- 1) Switching between transmission and reception by PTT signal input.
- 2) Reading channel, frequency, and program data from the memory circuit.
- 3) Sending frequency program data to the PLL.
- 4) Controlling squelch on/off by the pulse signal input from the squelch circuit.
- 5) Controlling the audio mute circuit by decode data input.
- 6) Transmitting encode data (QT, DTQ).
- 7) Sending serial data to output expander (IC400, IC403, IC404 and IC405) to control various function in the unit.

7-1. Memory circuit

IC406 has a flash memory with a capacity of 1M bits that contains the transceiver control program for the CPU and data such as transceiver channels and operating features.

This program can be easily written from an external devices. Data, such as DTMF memories and operating status, are programmed into the EEPROM (IC412).

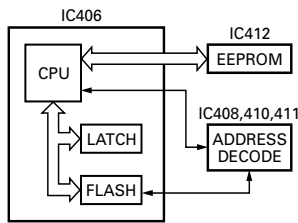

Fig. 13 Memory circuit

7-2. CPU clock shift

When the CPU (IC406) 14MHz clock (X400) high frequency (actually the integral double high frequency of 7MHz because it is halved) is multiplexed with the reception frequency, it becomes an internal beat signal, suppressing the signal sensitivity. To prevent this, by turning Q407 on, the clock frequency is shifted (about 4kHz).

(Shift on/off can be set through programming.)

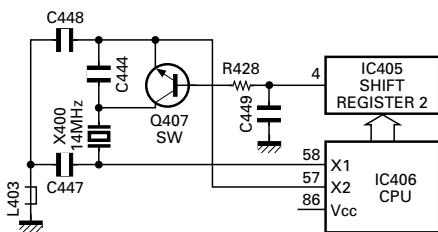

Fig. 14 CPU clock frequency shift

7-3. Shift register

IC400, 403, 404 and 405 is an interface IC for I/O port expansion. It is used to expand the CPU (IC406) output ports.

7-4. D/A converter

IC3 and IC603 is used as a conventional semi-fixed-resistor converter. It sets the following :

- 1) RX sensitivity
- 2) Transmission power
- 3) Modulation level
- 4) Audio power
- 5) Frequency

7-5. Key input

The clock is supplied to CLK terminal when the RES terminal (CPU pin 70) of the decade counter (IC2) is set to Low, Q0 to Q7 become High sequentially. Normally, K11 and K12 are Low (pulled down). When any key is pressed, K11 or K12 become High. The CPU detects which key is pressed, according to the voltage of K11 and K12 and clock timing.

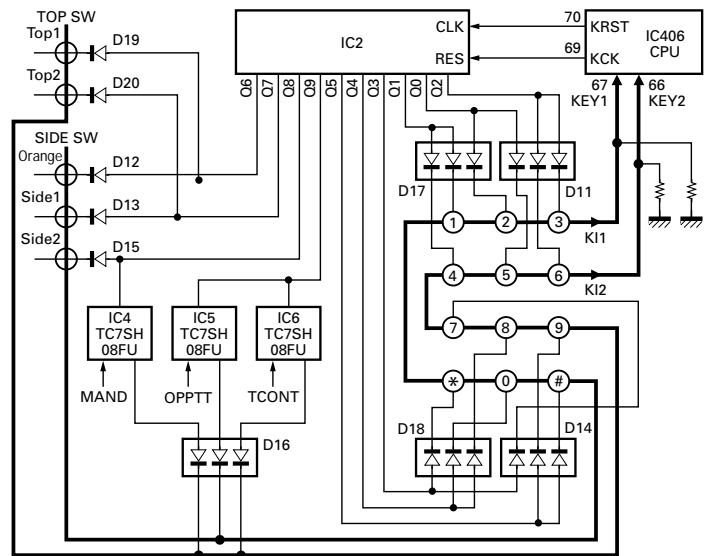

Fig. 15 Key input

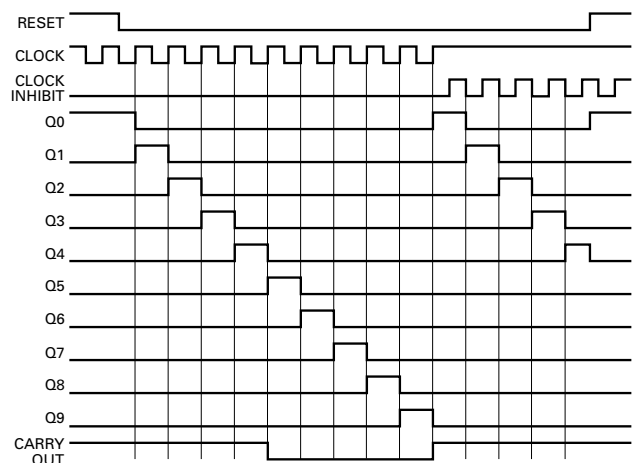

Fig. 16 Decade counter timing chart

CIRCUIT DESCRIPTION

7-6. Low battery warning

The battery voltage is monitored by the microprocessor (IC406). When the battery voltage falls below the voltage set by the Low Battery Warning adjustment, the red LED flashes to notify the operator that it is time to replace the battery. If the battery voltage falls even more (approx. 5.8V), a beep sounds and transmission is stopped.

Low battery warning	Battery condition
The red LED flashes during transmission	The battery voltage is low but the transceiver is still usable
The red LED flashes and continuous beep sounds while PTT pressed.	The battery voltage is low and the transceiver is not usable to make calls.

8. Signalling Circuit

8-1. Encode

The CPU (IC406) transmits the encode data selected by the program.

• Low-speed data (QT, DQT)

Low-speed data is output from pin 35 of the CPU. The signal passes through a low-pass CR filter, and goes to the summing amplifier (IC605 1/2). The signal is mixed with the audio signal and goes to the VCO (IC10) and VCXO (X1) modulation input after passing through the D/A converter (IC603) for BAL adjustment.

• High-speed data (DTMF)

High-speed data is output from pin 36 of the CPU. The signal passes through a low-pass filter consisting of IC413, and provides a TX DTMF tone and a RX DTMF tone including a beep tone. The TX DTMF tone is passed to the D/A converter (IC603) for DTMF deviation adjustment, and then applied to the audio processor (IC607).

The signal is mixed with the audio signal and goes to the VCO and VCXO. The RX DTMF tone is passed the D/A converter (IC603) for audio control, summing amplifier (IC604 2/2), audio power amplifier and then to the speaker.

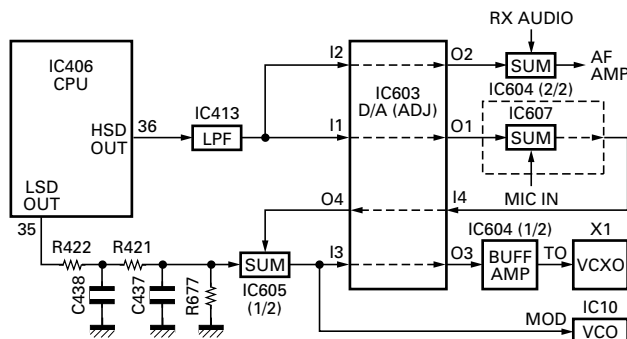

Fig. 17 Encode

8-2. Decode

• Low-speed data (QT, DQT)

The demodulated signal from the FM IF IC (IC300) is amplified by IC601 (2/2) and passes through a low-pass filter (IC602) to remove audio components. The signal is input to pin 26 of the CPU.

The CPU digitizes this signal, performs processing such as DC restoration, and decodes the signal.

• High-speed data (DTMF)

The DTMF input signal from the FM IF IC (IC300) is amplified by IC601 (2/2) and goes to IC600, the DTMF decoder. The decoded information is then processed by the CPU. During transmission and standby, the DTMF IC is set to the power down mode when the PD terminal is High. When the line is busy, the PD terminal becomes Low, the power down mode is canceled and decoding is carried out.

• High-speed data (2 tone)

The demodulated signal from the FM IF IC (IC300) is amplified by IC601 (2/2) and passes through an audio processor (IC607) and band-pass filter (IC606) to remove a low-speed data.

The CPU digitizes this signal, performs processing such as DC restoration, and decodes the signal.

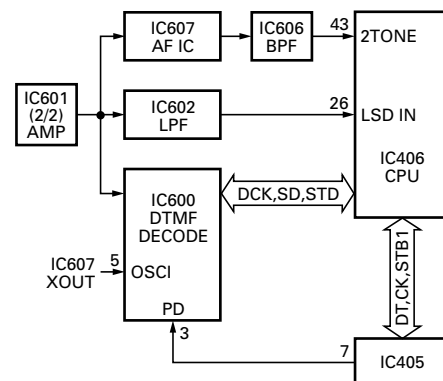

Fig. 18 Decode

CIRCUIT DESCRIPTION

9. Option Board Terminal

Terminals for mounting the option board are provided at the bottom of the TX-RX unit. The table below shows the correspondence between the board and terminals. Disconnect R414 and R665 in TX-RX unit when the option board is attached.

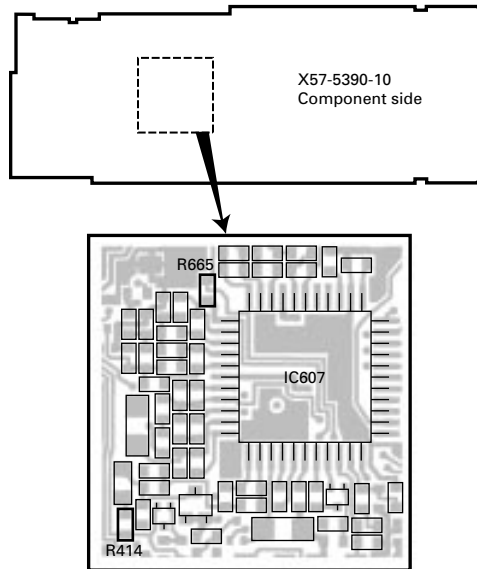

Fig. 19

9-1. Option port 1 (For ANI board etc.)

Name	Function	Note
DATI	Data input Received signal to board	Reference 1kHz STD Dev → 250~350mVrms
DATO	Data output Modulation (ANI) output from board	Reference 1kHz/150mVrms → 2.5~3.5kHz/wide 1.25~1.75kHz/narrow
TCONT	SP amp control from board	
STONE	Side tone from board	
AUDIH	MIC inhibit from board	
E	Ground	
MUTE	AF mute from board	
SCALL	Sel call LED port from board	No connection
AUX	EM CH request from board	EM : Emergency
PTT	PTT logic to board	
MAND	Man down logic to board	
EMERG	EM CH logic to board	EM : Emergency
BUSY	Busy logic to board	
KEY	TX request from board	TX : Transmission
A+	Power supply for board	Switched

9-2. Option port 2 (For voice scrambler etc.)

Name	Function	Note
CODE1	Scramble code select port 1	LSB
CODE2	Scramble code select port 2	
CODE3	Scramble code select port 3	
CODE4	Scramble code select port 4	MSB
TXOUT	Modulation output from board	Reference 1kHz/15mVrms → 2.5~3.5kHz/wide 1.25~1.75kHz/narrow
RXOUT	Received signal output from board	
NC	No Connection	
E	Ground	
PTTIO	TX (Low) / RX (High) to board	
CLR/C (AUX)	Clear (High) / Scramble (Low) to board (C : means Code)	
RXAEN	Power save request for board Save : Low	
RXIN	Received signal input to board	Reference 1kHz STD Dev → 250~350mVrms
TXIN	Modulation input to board	
+V	Power supply for board	Switched

SEMICONDUCTOR DATA

1. Microprocessor : MC-8800-802 (TX-RX Unit IC406)

1-1. Terminal function

Pin No.	Port name	I/O	Function	Pin No.	Port name	I/O	Function
1~4	A7~A4	I	NC : Flash memory address bus	49	DCK	O	DTMF clock
5~7	AD5~AD3	I/O	NC : Flash memory address and data bus	50	SCL	O	EEPROM clock
8~11	A3~A0	I	NC : Flash memory address bus	51	GND	-	GND
12	Vcc	-	+5V.	52	SDA	I/O	EEPROM data
13	OE	I	GND : Address latch output enable	53	LD	O	DA converter LD
14	VSS	I	GND : Test port	54	MSTB	O	MSK modulation strobe
15~18	CH A~CH D	I	Rotary SW 1~4	55	MSKE	O	MSK modulation enable
19	TGL	I	Toggle switch input	56	RESET	I	μ-com reset Active : L
20	LE	O	PLL enable	57,58	X2, X1	-	14.754MHz (System clock)
21	DATA	O	Common data	59	FCLR	O	MSK flame reset output
22	CLOCK	O	Common clock	60	RDT	I	MSK demodulation data input
23	VOL	I	Volume level input	61,62	STB2, STB1	O	Shift register strobe 2, 1
24	PF	I	SP key 1/2	63	SOE	O	Shift register output enable
25	TEMP	I	TEMP	64	PTT	I	PTT key input
26	LSDIN	I	Low speed data input (QT/DQT)	65	LCDCS	O	LCD driver chip select output
27	BATT	I	Battery voltage input	66,67	KEY2, KEY1	I	Key counter return 2, 1
28	UL	I	PLL unlock detect input	68	LCDDO	I	Radio kill data input for optional board
29	GND	-	GND	69	KCK	O	Key counter clock output
30	MDATA	O	Modem data input	70	KRST	O	Key counter reset output
31	EXSP	I	EXT SP Connect : L, Non connect : H	71	A10	I/O	NC : Not used
32	AVDD	-	+5V	72	RD	O	Flash ROM read bus
33	AVREF1	-	+5V	73	OE	I	Flash ROM output enable
34	AVSS	-	GND	74	A17	I/O	Flash memory address and data bus
35	LSDOUT	O	Low speed data output (QT/DQT)	75	CE	I	Flash memory chip enable
36	HSDOUT	O	High speed data output (DTMF/Beep)	76	A11	I/O	NC
37	AVREF2	-	+5V	77	A14	I/O	NC
38	AVREF3	-	GND	78,79	-	-	NC : Not used
39	SELF	I	Self programming enable/disable H : Enable, L : Disable	80	GND	-	GND
40	INTP0	I	μ-com stop	81,82	A9, A8	I/O	NC
41	STD	I	DTMF decoder STD	83,84	A13, A14	I/O	NC
42	BUSY	I	Noise pulse input	85	WR	O	Flash ROM write bus
43	2TONE	I	2 tone data input	86	Vcc	-	+5V
44	TRD	I	MSK modulation data output timing pulse input	87,88	A16, A15	I/O	A16, A15
45	RTM	I	MSK demodulation data input timing pulse input	89,90	A16, A15	I	A16, A15 : Flash memory address bus
46	SD	I	DTMF decoder SD	91	A12	I/O	NC
47	RXD	I	Serial interface input	92	NC	-	NC : Not used
48	TXD	O	Serial interface output	93~95	AD2~AD0	I/O	NC
				96,97	AD7, AD6	I/O	NC
				98,99	GND	-	GND
				100	ASTB	I/O	NC : Flash memory address strobe

2. D/A Converter : M62354GP (TX-RX Unit IC3)

2-1. Terminal connection

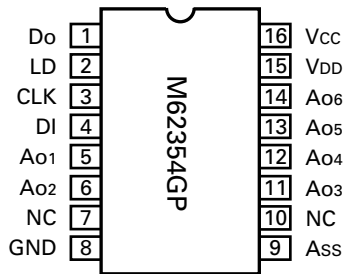

2-2. Block diagram

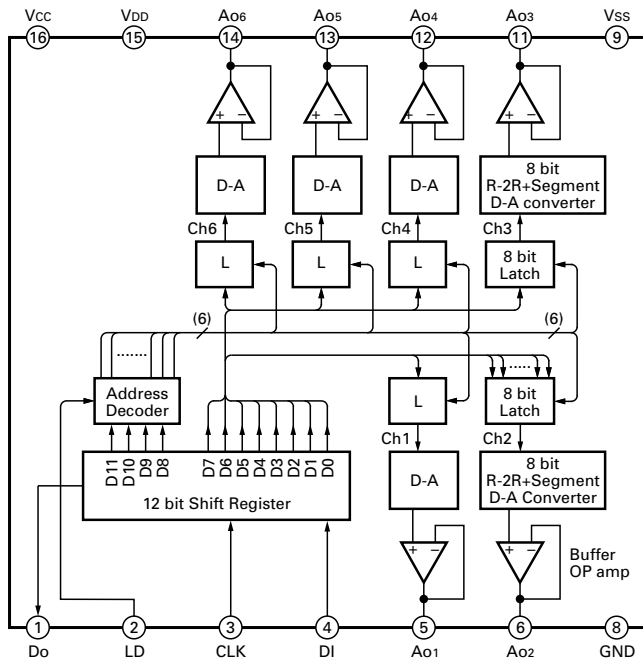

2-3. Terminal function

Pin No.	Symbol	I/O	Function
1	Do	O	12-bit shift register MSB bit data is output.
2	LD	I	When the LD is at the high level, the 12-bit shift register value is loaded to the D/A output register.
3	CLK	I	Shift clock input. With the rise of the shift clock, the input signal from the DI is input to the 12-bit shift register.
4	DI	I	Serial data input. Input serial data 12 bits long.
5,6	A01, A02	O	8-bit resolution D/A.
7	NC	-	Not connected.
8	GND	-	GND.
9	Vss	-	Terminal for determining the D/A conversion reference low side point level.
10	NC	-	Not connected.
11~14	A03~A06	O	8-bit resolution D/A.
15	VDD	-	Terminal for determining the D/A conversion reference up side point level.
16	Vcc	-	Power supply.

3. RF Power Amplifier : PHW2627-1 (Control Unit IC501)

3-1. Block diagram

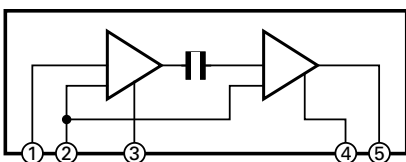

3-2. Maximum ratings (Flange temperature = 25°C)

Rating	Symbol	Value	Unit
DC supply voltage	VS1,2	10	Vdc
DC control voltage	Vcont	10	Vdc
RF input power	Pin	15	dBm
RF output power	Pout	8	W
Operating case temperature range	Tc	-30 to +100	°C
Storage temperature range	Tstg	-30 to +100	°C

SEMICONDUCTOR DATA

4. DC-DC Converter : MAX865 (TX-RX Unit IC4)

4-1. Terminal connection

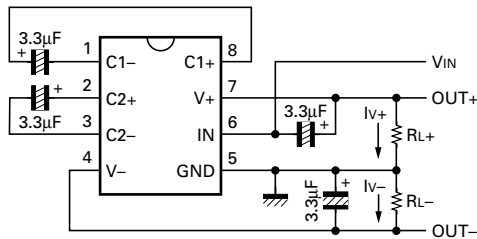

4-2. Terminal description

Pin No.	Name	Function
1	C1-	Negative terminal of the flying boost capacitor.
2	C2+	Positive terminal of the flying inverting capacitor.
3	C2-	Negative terminal of the flying inverting capacitor.
4	V-	Output of the inverting charge pump.
5	GND	Ground
6	IN	Positive power supply input
7	V+	Output of the boost charge pump.
8	C1+	Positive terminal of the flying boost capacitor.

4-3. Electrical characteristics

Parameter	Conditions	MIN	TYP	MAX	Units
Minimum supply voltage	RLOAD=10k	2.0	1.5		V
Maximum supply voltage	RLOAD=10k			6.0	V
Supply current	TA=+25°C		0.6	1.05	mA
	TA=-40°C to +85°C (Note 1)			1.15	
Oscillator frequency	TA=+25°C	19.5	24	32.5	kHz
	TA=-40°C to +85°C (Note 1)	18		34	

Note 1 : These specifications are guaranteed by design and are not production tested.

5. LCD Driver : LC75824W (Control unit IC101)

5-1. Block diagram

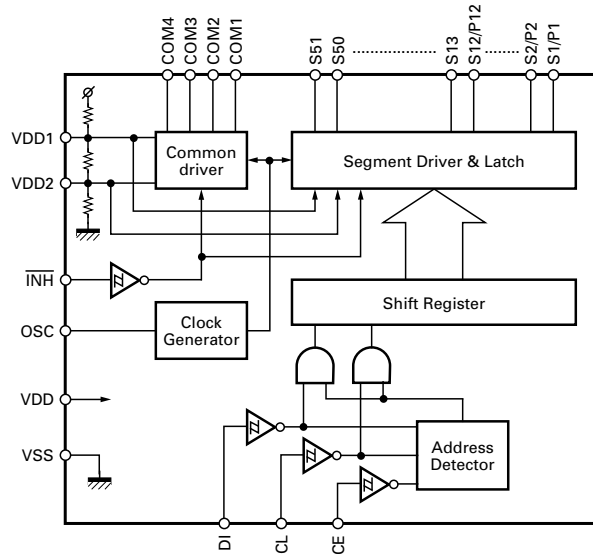

5-2. Terminal function

Pin No.	Name	I/O	Active	Function
1~12	S1/P1~S12/P12	O	-	Segment output for displaying data transferred from serial data.
13~51	S13~S51			
52~55	COM1~COM4	O	-	Common driver output. Frame frequency $f_o = (f_{osc}/512)$ Hz
56	VDD	-	-	
57	VDD1	I	-	Apply 2/3 the LCD drive bias voltage from outside. If 1/2 the bias is applied, connect to VDD2.
58	VDD2	I	-	Apply 1/3 the LCD drive bias voltage from outside. If 1/2 the bias is applied, connect to VDD1.
59	VSS	-	-	
60	OSC	I/O	-	Oscillation terminal.
61	INH	I	L	Force the display to turn off regardless of internal data. Serial data can be input regardless of whether it is "H" or "L".
62	CE	I	H	Chip enable. Serial data transfer terminal. Connected to the microprocessor.
63	CL	I	\uparrow	Synchronizing clock. Serial data transfer terminal. Connected to the microprocessor.
64	DI	I	-	Transfer data. Serial data transfer terminal. Connected to the microprocessor.

SEMICONDUCTOR DATA / DESCRIPTION OF COMPONENTS

6. VCO System : KCH40 (TX-RX Unit IC10)

6-1. Circuit diagram

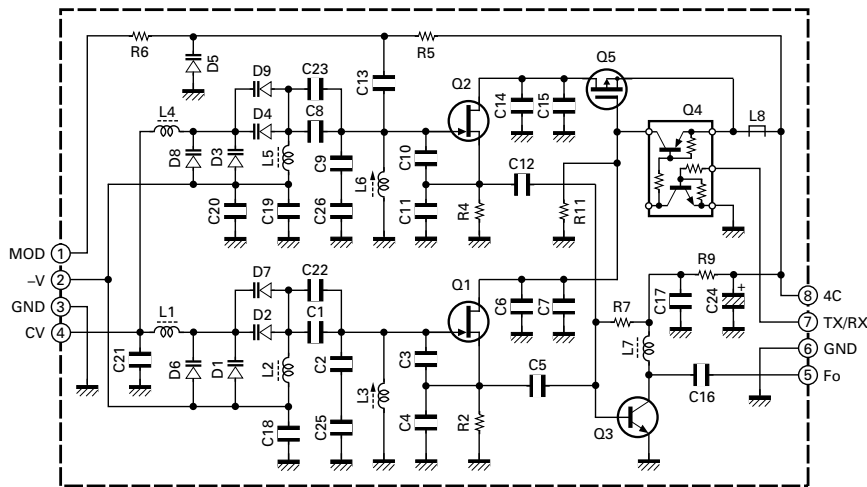

7. Active DBM : GN2011 (TX-RX Unit IC200)

7-1. Circuit diagram

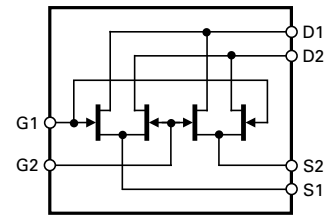

Control Unit (X53-3780-XX) -10 : K -11 : K2

Ref. No.	Use / Function	Operation / Condition	Ref. No.	Use / Function	Operation / Condition
IC1	Audio power amplifier	0.5W/16 , BTL method	Q14	N/C switch	N/C switch "H" : N/C on
IC2	Decimal counter		Q15	Ext. audio mute switch	EXT AFC "H" : EXT. SP audio signal on
IC3	MIC noise canceling circuit		D2	AVR	AF AMP power supply
IC4	Option board (MAND) control switch	AND circuit MAND : "H", OUT : "H" when Q8 port is "H"	D6~9	Key pad backlight	
IC5	Option board (OPPTT) control switch	AND circuit OPPTT : "H", OUT : "H" when Q9 port is "H"	D11	Reverse current prevention for number key pad	
IC6	Option board (TCONT) control switch	AND circuit MAND : "H", OUT : "H" when Q9 port is "H"	D12,13	Reverse current prevention for PF key.	
IC101	LCD driver		D14	Reverse current prevention for number key pad	
IC501	RF power amplifier		D15,16	Reverse current prevention for PF key.	
Q5	AF AMP switch	AF AMP SW "H" : on	D17,18	Reverse current prevention for number key pad	
Q6	AVR	AF AMP switch power supply	D19,20	Reverse current prevention for PF key.	
Q7	Int. audio mute switch	INT. AFC "H" : INT. SP audio signal on	D101	Speed up	
Q8	Audio mute switch signal off	MUTE "L" : RX audio	D102,103	LCD backlight	
			D104	LED	Red, green

DESCRIPTION OF COMPONENTS

TX-RX Unit (X57-5390-10)

Ref. No.	Use / Function	Operation / Condition	Ref. No.	Use / Function	Operation / Condition
IC2	Level shift		Q300	DC switch	1st IF W/N switch sets to on when Narrow
IC3	D/A converter (adjustment)		Q301	DC switch	1st IF W/N switch sets to on when Wide
IC4	DC-DC converter	Outputs \pm twice the input voltage 5M	Q302	IF amplifier	Post amplifier
IC5	Phase locked loop system		Q303	DC switch	2nd IF W/N switch sets to on when Narrow
IC6	Level shift		Q304	DC switch	2nd IF W/N switch sets to on when Wide
IC7	APC comparator		Q305	DC switch	
IC10	VCO system		Q307	DC switch	
IC200	Active DBM		Q400	DC switch	5TC "H" : on
IC300	FM IF system	2nd mixer, Quadrature detector, AF output, Noise amplifier output, S-meter output	Q401	DC switch	5CC "H" : on, 5TC "H" : on
IC301	Audio mute switch		Q402	DC switch	Regulator 5T, 5C
IC400	Shift register	Output expander	Q403	DC switch	MIC mute
IC401	Voltage regulator	5CM	Q404	DC switch	MIC switch
IC402	Voltage regulator	5M	Q405	DC switch	5CC "H" : on
IC403~405	Shift register	Output expander	Q406	DC switch	5R
IC406	Microprocessor	16 bit +1M flash	Q407	Clock frequency shift	
IC407	Voltage detector	INTPO	Q408	DC switch	TX LED (Red) driver
IC408	Address decoder	AND gate	Q409	DC switch	Busy LED (Green) driver
IC409	Voltage detector	Reset	Q410	DC switch	Lamp
IC410	Address decoder	OR gate	Q411	Current driver	Lamp : Backlight
IC411	Address decoder	NOR gate	Q600	DC switch	Clip
IC412	EEPROM		Q601	Mute switch	MIC line mute
IC413	Active filter	For HSD output	Q602	DC switch	
IC600	DTMF decoder		Q603	DC switch	SQL : W/N adjustment
IC601	Buffer amplifier		D4	Noise rejection	
IC602	Active filter	LPF for LSD input	D5	Frequency shift	2nd local cutoff frequency
IC603	D/A converter (Adjustment)		D6	Current steering	
IC604	Summing amplifier/ Buffer amplifier	AF/TO	D7	TX/RX switch	
IC605	Active filter/ Summing amplifier	SQL : HPF, MOD : Summing amplifier	D8	Temperature compensation	
IC606	Active filter	LPF for 2 tone	D9	Voltage protection	
IC607	Audio processor		D10,11	ANT switch	
Q1	DC switch	T/R "H" : RX	D200	Overload protection	
Q2	DC convert switch		D201,202	Varactor tuning	For L201
Q3	RF amplifier	Buffer for RF input	D203,204	Varactor tuning	For L202
Q4	Ripple filter	4C	D205,206	Varactor tuning	For L205
Q5	Buffer amplifier		D207,208	Varactor tuning	For L206
Q6	RF amplifier	TX drive	D300,301	RF switch	1st IF wide/narrow
Q7	DC switch	APC circuit power switch	D302,303	RF switch	2nd IF wide/narrow
Q8	RF amplifier	TX drive	D400	Reverse protection	
Q9	DC switch	APC voltage control	D401	Overload protection	
Q10	DC switch	APC off : Speed up	D402,403	Surge absorption	
Q13	DC switch	D/A port protection	D409	Voltage reference	
Q200	RF amplifier	RX front	D601	Voltage clamp	

TK-290

* New Parts. Δ indicates safety critical components.

Parts without **Parts No.** are not supplied.

Les articles non mentionnés dans le **Parts No.** ne sont pas fournis.

Teile ohne **Parts No.** werden nicht geliefert.

L : Scandinavia

Y : PX (Far East, Hawaii)

Y : AAFES (Europe)

K : USA

T : England

X : Australia

P : Canada

E : Europe

M : Other Areas

TK-290

CONTROL UNIT (X53-3780-XX)

Ref. No.	Address	New parts	Parts No.	Description	Destination
TK-290					
1	1A	*	A02-2139-43	CABINET ASSY	K
	1A	*	A02-2140-43	CABINET ASSY (10KEY)	K2
2	3A	*	A10-1374-31	CHASSIS	
3	2B	*	A22-2501-15	SUB PANEL ASSY	
4	3B	*	A62-0537-33	PANEL ASSY	
6	1C	*	B03-0594-04	DRESSING PLATE ACSY	
7	1C		B09-0363-03	CAP (UNIVERSAL) ACSY	
8	1B	*	B11-1183-14	REFLECTOR (LCD)	
9	1B	*	B38-0786-05	LCD	
10	1A		B42-3394-14	STANDARD LABEL	
11	1A	*	B43-1111-04	BADGE KENWOOD	
12	1D		B46-0470-00	WARRANTY CARD	
13	1D	*	B62-0816-00	INSTRUCTION MANUAL	
14	3A	*	B72-1288-04	MODEL NAME PLATE	
16	1D	*	D32-0421-24	STOPPER ACSY	
17	3A		E23-1048-05	TERMINAL (BATT-)	
18	3A	*	E23-1062-05	TERMINAL (BATT +)	
20	1B	*	E29-1165-05	INTER CONNECTOR (LCD)	
21	2A	*	E37-0682-05	FLAT CABLE (TX/RX-CONT)	
22	1B	*	E37-0684-05	LEAD WIRE WITH CONNECTOR (SP)	
23	2B	*	E37-0692-05	PROCESSED LEAD WIRE (TOGGLE SW)	
24	2B	*	E37-0722-05	LEAD WIRE WITH CONNECTOR (ANT COAXIAL)	
-	-	*	E37-0777-05	PROCESSED LEAD WIRE (UNIVERSAL-GND)	
26	3B	*	E58-0443-15	UNIVERSAL CONNECTOR	
27	2A	*	G01-0891-04	COIL SPRING (BATT RELEASE)	
-	-	*	G11-2538-04	SHEET (UNIVERSAL-CHASSIS)	
30	2A,3A	*	G13-1678-04	CUSHION	
-	-	*	G13-1688-04	CUSHION (CAP)	
31	3A		G53-0814-04	PACKING (BATT +)	
32	3B	*	G53-0822-04	PACKING (CHASSIS)	
33	1B	*	G53-0823-04	PACKING (SP)	
34	2A	*	G53-0824-13	PACKING (CABINET)	
36	2C	*	H12-3018-02	PACKING FIXTURE	
37	1C		H25-0029-04	PROTECTION BAG ACSY	
38	3D	*	H52-0998-02	ITEM CARTON CASE	
40	2A	*	J19-5330-14	HOLDER (BATT RELEASE)	
41	1A	*	J21-8326-14	HARDWARE FIXTURE (SIDE KEY)	
42	1B	*	J21-8328-14	HARDWARE FIXTURE (LCD)	
43	2A	*	J21-8329-14	HARDWARE FIXTURE (CONT UNIT)	
44	3A	*	J21-8330-04	HARDWARE FIXTURE (POWER MUDULE)	
45	2B	*	J21-8343-04	HARDWARE FIXTURE	
46	1C	*	J29-0652-05	CLIP ACSY	
47	1A	*	J82-0047-05	FPC (SIDE KEY)	
48	3B	*	J82-0049-05	FPC (VOL-ENC)	
49	3B	*	J82-0052-15	FPC (UNIVERSAL CONNECTOR)	
50	2B	*	J99-0346-14	ADHESIVE TAPE (TOGGLE SW)	
52	2B	*	K29-5172-12	KEY TOP (TOP)	
53	1A	*	K29-5173-13	KEY TOP (SIDE)	
54	2B	*	K29-5282-04	KNOB ASSY (SEL)	
55	2B	*	K29-5283-04	KNOB ASSY (VOL)	
56	1A	*	K29-5193-13	KEY TOP (10KEY)	K2

Ref. No.	Address	New parts	Parts No.	Description	Destination
57	1A	*	K29-5216-24	KNOB ASSY (SIDE KEY)	
58	2A	*	K29-5220-13	LEVER KNOB (BATT RELEASE)	
-	-		L33-0680-05	CHOKE COIL (POWER MUDULE)	
A	2B	*	N14-0577-04	CIRCULAR NUT (COAXIAL CON)	
B	2B	*	N14-0578-04	CIRCULAR NUT (VOL,ENC)	
C	3A		N30-2608-45	PAN HEAD MACHINE SCREW	
D	1A,2B	*	N78-2030-46	PAN HEAD TAPTITE SCREW	
E	2A,2B		N83-2004-46	PAN HEAD TAPTITE SCREW	
F	3A		N89-2605-46	BANDING HEAD TAPTITE SCREW	
62	1C		N99-2004-05	SCREW SET ACSY	
64	3B		R31-0626-05	VARIABLE RESISTOR	
66	3B	*	S60-0408-15	ROTARY SWITCH	
67	2B	*	S72-0402-05	TOGGLE SWITCH	
69	1B	*	T07-0349-05	SPEAKER	
70	2A,2B		T91-0575-05	MIC ELEMENT	

CONTROL UNIT (X53-3780-XX) -10 : K -11 : K2

D6-9			B30-2171-05	LED (10KEY BACK LIGHT)	K2
D102,103	*		B30-2190-05	LED (LCD BACK LIGHT)	
D104			B30-2019-05	LED (TX/BUSY)	
C1,2			CK73GB1H471K	CHIP C 470PF K	
C8			CK73FB1C474K	CHIP C 0.47UF K	
C12,13			CK73FB1C474K	CHIP C 0.47UF K	
C14			CK73FB1C104KTD	CHIP C 0.10UF K	
C15			CK73GB1H471K	CHIP C 470PF K	
C16	*		C92-0734-05	ELECTRO 100UF 10WV	
C19			CK73FB1C474K	CHIP C 0.47UF K	
C22			CK73GB1H471K	CHIP C 470PF K	
C27-29			CK73GB1C104K	CHIP C 0.10UF K	
C30			CK73FB1C474K	CHIP C 0.47UF K	
C31			CK73GB1E223K	CHIP C 0.022UF K	
C32			CK73FB1C474K	CHIP C 0.47UF K	
C33,34			CK73GB1H471K	CHIP C 470PF K	
C35			CK73GB1H102K	CHIP C 1000PF K	
C37			CC73GCH1H101J	CHIP C 100PF J	
C38			CK73GB1H102K	CHIP C 1000PF K	
C104			CC73GCH1H101J	CHIP C 100PF J	
C501			CK73GB1H183K	CHIP C 0.018UF K	
CN1	*		E40-5947-05	FLAT CABLE CONNECTOR	
CN2			E40-5662-05	PIN ASSY SOCKET	
CN3	*		E40-5948-05	FLAT CABLE CONNECTOR	
CN4			E40-5662-05	PIN ASSY SOCKET	
CN101	*		E40-5920-05	FLAT CABLE CONNECTOR	
CN501,502			E04-0403-05	PIN SOCKET	
L1-4			L92-0141-05	FERRITE CHIP	
L5			L92-0138-05	FERRITE CHIP	
L6			L92-0149-05	FERRITE CHIP	
L101			L92-0138-05	FERRITE CHIP	
CP1			R90-0723-05	MULTI-COMP 47K X2	
R1			RK73GB1J273J	CHIP R 27K J 1/16W	
R2			RK73GB1J102J	CHIP R 1.0K J 1/16W	

CONTROL UNIT (X53-3780-XX)
TX-RX UNIT (X57-5390-10)

Ref. No.	Address	New parts	Parts No.	Description	Destination	Ref. No.	Address	New parts	Parts No.	Description	Destination
R3			RK73GB1J470J	CHIP R 47 J 1/16W		C18			C92-0588-05	CHIP-TAN 1.5UF 16V	
R4,5			RK73GB1J473J	CHIP R 47K J 1/16W		C19,20			CK73GB1C104K	CHIP C 0.10UF K	
R6-8			R92-1252-05	CHIP R 0 OHM		C21			C92-0560-05	CHIP-TAN 10UF 6.3WV	
R9,10			RK73GB1J102J	CHIP R 1.0K J 1/16W		C22			CK73GB1H103K	CHIP C 0.010UF K	
R12			RK73GB1J102J	CHIP R 1.0K J 1/16W		C23			CC73GCH1H101J	CHIP C 100PF J	
R13			RK73GB1J473J	CHIP R 47K J 1/16W		C24			C92-0502-05	CHIP-TAN 0.33UF 35WV	
R14			RK73GB1J104J	CHIP R 100K J 1/16W		C27			CK73GB1C104K	CHIP C 0.10UF K	
R15			RK73GB1J222J	CHIP R 2.2K J 1/16W		C28			CK73GB1E223K	CHIP C 0.022UF K	
R17,18			RK73GB1J473J	CHIP R 47K J 1/16W		C29			CC73GCH1H100D	CHIP C 10PF D	
R19,20			RK73GB1J101J	CHIP R 100 J 1/16W	K2	C30			CC73GCH1H220J	CHIP C 22PF J	
R22,23			RK73GB1J102J	CHIP R 1.0K J 1/16W		C31			CK73GB1H471K	CHIP C 470PF K	
R26-28			RK73GB1J103J	CHIP R 10K J 1/16W		C32			C92-0002-05	CHIP-TAN 0.22UF 35WV	
R29,30			RK73GB1J223J	CHIP R 22K J 1/16W		C33			CC73GCH1H220J	CHIP C 22PF J	
R32			RK73GB1J680J	CHIP R 68 J 1/16W		C34			CC73GCH1H331J	CHIP C 330PF J	
R33			RK73GB1J223J	CHIP R 22K J 1/16W		C35			CC73GCH1H100D	CHIP C 10PF D	
R34			RK73GB1J182J	CHIP R 1.8K J 1/16W		C36			CC73GCH1H150J	CHIP C 15PF J	
R35			RK73GB1J103J	CHIP R 10K J 1/16W		C37			CK73GB1H471K	CHIP C 470PF K	
R36			RK73GB1J182J	CHIP R 1.8K J 1/16W	K	C38			CC73GCH1H050C	CHIP C 5.0PF C	
R36-42			RK73GB1J102J	CHIP R 1.0K J 1/16W	K2	C39			CK73GB1H102K	CHIP C 1000PF K	
R43,44			RK73GB1J473J	CHIP R 47K J 1/16W		C40			C92-0560-05	CHIP-TAN 10UF 6.3WV	
R45-49			RK73GB1J102J	CHIP R 1.0K J 1/16W	K	C41			CK73GB1H471K	CHIP C 470PF K	
R45-55			RK73GB1J102J	CHIP R 1.0K J 1/16W	K2	C42			CC73GCH1H100D	CHIP C 10PF D	
R56			RK73GB1J153J	CHIP R 15K J 1/16W		C43			C92-0507-05	CHIP-TAN 4.7UF 6.3WV	
R57			R92-1252-05	CHIP R 0 OHM		C45			CC73GCH1H120J	CHIP C 12PF J	
R59			RK73GB1J102J	CHIP R 1.0K J 1/16W		C46			CK73GB1H102K	CHIP C 1000PF K	
R101-104			RK73GB1J103J	CHIP R 10K J 1/16W		C47			CK73GB1H471K	CHIP C 470PF K	
R105			RK73GB1J332J	CHIP R 3.3K J 1/16W		C48			CK73GB1H102K	CHIP C 1000PF K	
R106			RK73GB1J274J	CHIP R 270K J 1/16W		C49,50			CK73GB1H471K	CHIP C 470PF K	
R502			RK73GB1J102J	CHIP R 1.0K J 1/16W		C52			CK73GB1H102K	CHIP C 1000PF K	
D2			DTZ3.9(B)	ZENER DIODE		C53-57			CK73GB1H471K	CHIP C 470PF K	
D11			IMN10	DIODE	K2	C58			CC73GCH1H101J	CHIP C 100PF J	
D12,13			MA2S111	DIODE		C59			CC73GCH1H680J	CHIP C 68PF J	
D14			IMN10	DIODE	K2	C60-64			CK73GB1H471K	CHIP C 470PF K	
D15			MA2S111	DIODE		C66,67			CK73GB1H471K	CHIP C 470PF K	
D16			IMN10	DIODE	K	C69			CC73GCH1H390J	CHIP C 39PF J	
D16-18			IMN10	DIODE	K2	C70			CC73GCH1H101J	CHIP C 100PF J	
D19,20			MA2S111	DIODE		C71			CK73FB1C474K	CHIP C 0.47UF K	
D101			1SS373	DIODE		C73			C92-0543-05	CHIP-TAN 3.3UF 10WV	
IC1			TDA7053AT	IC (AUDIO AMP)		C76			CC73GCH1H101J	CHIP C 100PF J	
IC2			MC74HC4017F	IC (GATE CMOS)		C77			CC73GCH1H070D	CHIP C 7.0PF D	
IC3			NJM2904V	IC (APC)		C78			CK73GB1H103K	CHIP C 0.010UF K	
IC4-6			TC7SH08FU	IC (2ch AND GATE)		C79			CK73FB1C474K	CHIP C 0.47UF K	
IC101	*		LC75824W	IC (LCD DRIVER)		C81,82			CK73GB1H102K	CHIP C 1000PF K	
IC501	*		PHW2627-1	IC (POWER MUDULE)		C83			CC73GCH1H200J	CHIP C 20PF J	
O5			2SC4617(S)	TRANSISTOR		C84,85			CK73GB1H102K	CHIP C 1000PF K	
O6			2SB798(DL,DK)	TRANSISTOR		C86			CC73GCH1H220J	CHIP C 22PF J	
O7,8			2SK1824	FET		C87			CK73GB1H102K	CHIP C 1000PF K	
O14			UMC4	TRANSISTOR		C88			CC73GCH1H120J	CHIP C 12PF J	
O15			2SK1824	FET		C89			CC73GCH1H090D	CHIP C 9.0PF D	
TX-RX UNIT (X57-5390-10)						C90			CC73GCH1H270J	CHIP C 27PF J	
C1			C92-0560-05	CHIP-TAN 10UF 6.3WV		C91			CC73GCH1H100D	CHIP C 10PF D	
C5			CK73GB1H102K	CHIP C 1000PF K		C92			CC73GCH1H120J	CHIP C 12PF J	
C6			C92-0560-05	CHIP-TAN 10UF 6.3WV		C93,94			CC73GCH1H100D	CHIP C 10PF D	
C8-10			CK73GB1H102K	CHIP C 1000PF K		C95-97			CK73GB1H102K	CHIP C 1000PF K	
C11			C92-0588-05	CHIP-TAN 1.5UF 16V		C99			CK73GB1H102K	CHIP C 1000PF K	
C13			CK73GB1C104K	CHIP C 0.10UF K		C100			C92-0560-05	CHIP-TAN 10UF 6.3WV	
C14,15			C92-0588-05	CHIP-TAN 1.5UF 16V		C202			CC73GCH1H060D	CHIP C 6.0PF D	
C16			CK73GB1C104K	CHIP C 0.10UF K		C204			CK73GB1H102K	CHIP C 1000PF K	
C17			CK73GB1H102K	CHIP C 1000PF K		C205			CC73GCH1H030C	CHIP C 3.0PF C	
						C206,207			CK73GB1H102K	CHIP C 1000PF K	

TK-290

TX-RX UNIT (X57-5390-10)

Ref. No.	Address	New parts	Parts No.	Description	Destination	Ref. No.	Address	New parts	Parts No.	Description	Destination
C209,210			CK73GB1H102K	CHIP C 1000PF K		C441			CK73HB1C103K	CHIP C 0.010UF K	
C212,213			CK73GB1H102K	CHIP C 1000PF K		C442			CK73FB1C474K	CHIP C 0.47UF K	
C214			CC73GCH1H060D	CHIP C 6.0PF D		C443			CK73GB1H222K	CHIP C 2200PF K	
C215			CC73GCH1H030C	CHIP C 3.0PF C		C444			CC73GCH1H680J	CHIP C 68PF J	
C216			CC73GCH1H010C	CHIP C 1.0PF C		C445,446			CK73GB1H222K	CHIP C 2200PF K	
C217			CK73GB1H102K	CHIP C 1000PF K		C447,448			CC73GCH1H270J	CHIP C 27PF J	
C219			CC73GCH1H060D	CHIP C 6.0PF D		C449			CK73GB1H103K	CHIP C 0.010UF K	
C222			CC73GCH1H151J	CHIP C 150PF J		C450			C92-0560-05	CHIP-TAN 10UF 6.3WV	
C223			CC73GCH1H070D	CHIP C 7.0PF D		C451-454			CC73GCH1H101J	CHIP C 100PF J	
C224			CK73GB1H471K	CHIP C 470PF K		C456-477			CC73GCH1H101J	CHIP C 100PF J	
C225			CC73GCH1H151J	CHIP C 150PF J		C478			CK73GB1C104K	CHIP C 0.10UF K	
C226-228			CK73GB1H471K	CHIP C 470PF K		C479			CC73GCH1H271J	CHIP C 270PF J	
C229,230			CK73GB1C104K	CHIP C 0.10UF K		C480			CC73GCH1H221J	CHIP C 220PF J	
C232			CC73GCH1H151J	CHIP C 150PF J		C481			CK73GB1H102K	CHIP C 1000PF K	
C233,234			CK73GB1H102K	CHIP C 1000PF K		C485			CC73GCH1H101J	CHIP C 100PF J	
C237,238			CK73GB1H102K	CHIP C 1000PF K		C600			CK73GB1C473K	CHIP C 0.047UF K	
C302,303			CC73GCH1H040C	CHIP C 4.0PF C		C601			C92-0003-05	CHIP-TAN 0.47UF 25WV	
C304			CK73GB1H102K	CHIP C 1000PF K		C602			CK73GB1C104K	CHIP C 0.10UF K	
C305			CK73GB1H103K	CHIP C 0.010UF K		C603			CK73GB1C683K	CHIP C 0.068UF K	
C306-308			CK73GB1H102K	CHIP C 1000PF K		C604			CK73GB1H103K	CHIP C 0.010UF K	
C309			C92-0560-05	CHIP-TAN 10UF 6.3WV		C606			CK73GB1H222K	CHIP C 2200PF K	
C310,311			CK73GB1C104K	CHIP C 0.10UF K		C607			CC73GCH1H101J	CHIP C 100PF J	
C312			CK73GB1H103K	CHIP C 0.010UF K		C608			CK73GB1H103K	CHIP C 0.010UF K	
C313,314			CC73GCH1H220J	CHIP C 22PF J		C609			CC73GCH1H121J	CHIP C 120PF J	
C315			CK73GB1H102K	CHIP C 1000PF K		C610			CK73GB1H103K	CHIP C 0.010UF K	
C316			CC73GCH1H820J	CHIP C 82PF J		C611			CK73GB1E123K	CHIP C 0.012UF K	
C317			CK73GB1H102K	CHIP C 1000PF K		C612			C92-0507-05	CHIP-TAN 4.7UF 6.3WV	
C318			CK73GB1C104K	CHIP C 0.10UF K		C613			CK73GB1H103K	CHIP C 0.010UF K	
C319			CK73GB1H103K	CHIP C 0.010UF K		C615			CC73GCH1H200J	CHIP C 20PF J	
C320			C92-0560-05	CHIP-TAN 10UF 6.3WV		C619			CK73GB1H471K	CHIP C 470PF K	
C321			CK73GB1C104K	CHIP C 0.10UF K		C621			CK73GB1C104K	CHIP C 0.10UF K	
C322			CK73GB1H103K	CHIP C 0.010UF K		C623			CK73GB1E103K	CHIP C 0.010UF K	
C323			C92-0560-05	CHIP-TAN 10UF 6.3WV		C625,626			CK73GB1C104K	CHIP C 0.10UF K	
C327-331			CK73GB1H103K	CHIP C 0.010UF K		C627			CK73GB1H122K	CHIP C 1200PF K	
C400,401			CC73GCH1H101J	CHIP C 100PF J		C629,630			CK73GB1H103K	CHIP C 0.010UF K	
C403-411			CC73GCH1H101J	CHIP C 100PF J		C631,632			CK73GB1C104K	CHIP C 0.10UF K	
C413			CK73GB1H471K	CHIP C 470PF K		C633			CK73GB1H103K	CHIP C 0.010UF K	
C414			CK73GB1H103K	CHIP C 0.010UF K		C634,635			CK73GB1H562K	CHIP C 5600PF K	
C415			CK73FB0J105K	CHIP C 1.0UF K		C636			CK73GB1C333K	CHIP C 0.033UF K	
C416,417			CK73GB1H471K	CHIP C 470PF K		C637			CK73GB1H562K	CHIP C 5600PF K	
C419			C92-0589-05	CHIP-TAN 47UF 6.3WV		C638			CK73GB1H272K	CHIP C 2700PF K	
C420		*	C92-0702-05	ELECTRO 47UF 6.3WV		C639			CC73GCH1H090D	CHIP C 9.0PF D	
C421			CK73GB1H471K	CHIP C 470PF K		C640,641			CK73GB1H272K	CHIP C 2700PF K	
C422			CK73FF1C105Z	CHIP C 1.0UF Z		C642			CC73GCH1H151J	CHIP C 150PF J	
C423,424			CK73GB1H471K	CHIP C 470PF K		C643			CK73GB1H122K	CHIP C 1200PF K	
C425			CK73GB1H103K	CHIP C 0.010UF K		C644			CK73GB1H102K	CHIP C 1000PF K	
C426			CK73GB1H471K	CHIP C 470PF K		C645			CC73GCH1H090D	CHIP C 9.0PF D	
C427			CK73GB1H103K	CHIP C 0.010UF K		C646			C92-0560-05	CHIP-TAN 10UF 6.3WV	
C428			C92-0004-05	CHIP-TAN 1.0UF 16WV		C647			CK73GB1C104K	CHIP C 0.10UF K	
C429			CK73GB1H102K	CHIP C 1000PF K		C648			CC73GCH1H101J	CHIP C 100PF J	
C430			CK73FB0J105K	CHIP C 1.0UF K		C649-651			CK73GB1C104K	CHIP C 0.10UF K	
C431			CK73GB1H471K	CHIP C 470PF K		C652			C92-0507-05	CHIP-TAN 4.7UF 6.3WV	
C432			CK73FB0J105K	CHIP C 1.0UF K		C653,654			CK73GB1H472K	CHIP C 4700PF K	
C433			C92-0698-05	ELECTRO 47UF 16WV		C655			CC73GCH1H101J	CHIP C 100PF J	
C434,435		*	CK73GB1H471K	CHIP C 470PF K		C656			CK73FB1H563K	CHIP C 0.056UF K	
C436			CK73FF1C105Z	CHIP C 1.0UF Z		C657			C92-0507-05	CHIP-TAN 4.7UF 6.3WV	
C437			CK73GB1H472K	CHIP C 4700PF K		C659			CK73GB1C104K	CHIP C 0.10UF K	
C438			CK73GB1H103K	CHIP C 0.010UF K		C660			C92-0560-05	CHIP-TAN 10UF 6.3WV	
C439			CK73GB1E103K	CHIP C 0.010UF K		C661			CK73GB1C104K	CHIP C 0.10UF K	
C440			CK73GB1C273K	CHIP C 0.027UF K		C663			CK73GB1H102K	CHIP C 1000PF K	

TX-RX UNIT (X57-5390-10)

Ref. No.	Address	New parts	Parts No.	Description	Destination	Ref. No.	Address	New parts	Parts No.	Description	Destination
C664			CK73GB1C104K	CHIP C 0.10UF K		CP700-707			R90-0741-05	MULTIPLE RESISTOR	
C665			CK73GB1C333K	CHIP C 0.033UF K		CP711-716			R90-0741-05	MULTIPLE RESISTOR	
C666			CK73GB1E153K	CHIP C 0.015UF K		CP718-720			R90-0741-05	MULTIPLE RESISTOR	
C667			CC73GCH1H120J	CHIP C 12PF J		R4			R92-1252-05	CHIP R 0 OHM	
C668			CK73GB1H102K	CHIP C 1000PF K		R5			RK73GB1J104J	CHIP R 100K J 1/16W	
C669			CC73GCH1H101J	CHIP C 100PF J		R6			RK73GB1J473J	CHIP R 47K J 1/16W	
C681			CK73GB1E103K	CHIP C 0.010UF K		R7			RK73GB1J104J	CHIP R 100K J 1/16W	
C700-710			CC73HCH1H101J	CHIP C 100PF J		R8			RK73GB1J683J	CHIP R 68K J 1/16W	
C714-720			CC73HCH1H101J	CHIP C 100PF J		R9			RK73GB1J682J	CHIP R 6.8K J 1/16W	
C722-728			CC73HCH1H101J	CHIP C 100PF J		R11			RK73GB1J563J	CHIP R 56K J 1/16W	
CN400		*	E40-5563-05	FLAT CABLE CONNECTOR		R12			RK73GB1J100J	CHIP R 10 J 1/16W	
CN401		*	E40-5947-05	FLAT CABLE CONNECTOR		R13			RK73GB1J104J	CHIP R 100K J 1/16W	
CN402			E40-5662-05	PIN ASSY SOCKET		R14			RK73GB1J184J	CHIP R 180K J 1/16W	
CN403		*	E40-5856-05	FLAT CABLE CONNECTOR		R15			RK73GB1J682J	CHIP R 6.8K J 1/16W	
CN404,405			E23-0342-05	TEST TERMINAL		R16			RK73GB1J151J	CHIP R 150 J 1/16W	
F400		*	F53-0143-05	CHIP FUSE 3A		R17			RK73GB1J394J	CHIP R 390K J 1/16W	
CD300			L79-1072-05	CERAMIC DISCRI		R18			RK73GB1J102J	CHIP R 1.0K J 1/16W	
CF300,301			L72-0916-05	CERAMIC FILTER		R20-23			RK73GB1J473J	CHIP R 47K J 1/16W	
CF302,303			L72-0939-05	CERAMIC FILTER		R24			RK73GB1J101J	CHIP R 100 J 1/16W	
L1			L92-0138-05	FERRITE CHIP		R25			RK73GB1J224J	CHIP R 220K J 1/16W	
L3			L92-0138-05	FERRITE CHIP		R27			RK73GB1J472J	CHIP R 4.7K J 1/16W	
L4			L40-4775-44	SMALL FIXED INDUCTOR (47.0NH)		R28			RK73GB1J223J	CHIP R 22K J 1/16W	
L5			L40-3981-37	SMALL FIXED INDUCTOR (0.390UH)		R29			RK73GB1J104J	CHIP R 100K J 1/16W	
L6			L40-6875-44	SMALL FIXED INDUCTOR (68.0NH)		R31			RK73GB1J471J	CHIP R 470 J 1/16W	
L7			L40-1085-44	SMALL FIXED INDUCTOR (100.0NH)		R32			RK73GB1J122J	CHIP R 1.2K J 1/16W	
L8			L40-5675-44	SMALL FIXED INDUCTOR (56.0NH)		R33			RK73GB1J103J	CHIP R 10K J 1/16W	
L9		*	L40-8275-44	SMALL FIXED INDUCTOR (82.0NH)		R34			RK73GB1J223J	CHIP R 22K J 1/16W	
L10,11			L92-0149-05	FERRITE CHIP		R35			RK73EB2ER39K	CHIP R 0.39 K 1/4W	
L12			L33-0760-05	SMALL FIXED INDUCTOR		R36			R92-1252-05	CHIP R 0 OHM	
L13			L40-1095-34	SMALL FIXED INDUCTOR (1UH)		R37			RK73EB2ER39K	CHIP R 0.39 K 1/4W	
L14			L33-0765-05	SMALL FIXED INDUCTOR		R38			RK73GB1J222J	CHIP R 2.2K J 1/16W	
L15,16			L33-1226-05	SMALL FIXED INDUCTOR		R39			RK73EB2ER39K	CHIP R 0.39 K 1/4W	
L17			L40-1092-81	SMALL FIXED INDUCTOR		R40			RK73GB1J822J	CHIP R 8.2K J 1/16W	
L18			L40-4791-37	SMALL FIXED INDUCTOR (4.700UH)		R41,42			RN73GH1J154D	CHIP R 150K D 1/16W	
L20,21			L92-0140-05	FERRITE CHIP		R43			RK73GB1J180J	CHIP R 18 J 1/16W	
L201		*	L34-4492-05	COIL		R44,45			RN73GH1J154D	CHIP R 150K D 1/16W	
L202		*	L34-4493-05	COIL		R46			RK73GB1J101J	CHIP R 100 J 1/16W	
L204			L40-6885-34	SMALL FIXED INDUCTOR (680NH)		R47,48			RN73GH1J154D	CHIP R 150K D 1/16W	
L205		*	L34-4493-05	COIL		R49			RK73GB1J101J	CHIP R 100 J 1/16W	
L206		*	L34-4492-05	COIL		R50			RK73GB1J470J	CHIP R 47 J 1/16W	
L207		*	L40-8275-44	SMALL FIXED INDUCTOR (82.0NH)		R51			R92-1252-05	CHIP R 0 OHM	
L208			L40-5675-44	SMALL FIXED INDUCTOR (56.0NH)		R52			RK73GB1J103J	CHIP R 10K J 1/16W	
L209,210		*	L40-8275-44	SMALL FIXED INDUCTOR (82.0NH)		R53			RK73GB1J220J	CHIP R 22 J 1/16W	
L211,212			L39-1272-05	TOROIDAL COIL		R54			RK73GB1J152J	CHIP R 1.5K J 1/16W	
L213			L92-0138-05	FERRITE CHIP		R55			R92-1252-05	CHIP R 0 OHM	
L214			L39-1272-05	TOROIDAL COIL		R56			RK73GB1J473J	CHIP R 47K J 1/16W	
L215		*	L40-8275-44	SMALL FIXED INDUCTOR (82.0NH)		R57			RK73GB1J104J	CHIP R 100K J 1/16W	
L300			L40-1095-34	SMALL FIXED INDUCTOR (1UH)		R58			RK73GB1J105J	CHIP R 1.0M J 1/16W	
L301			L40-3391-37	SMALL FIXED INDUCTOR (3.300UH)		R59			RK73GB1J104J	CHIP R 100K J 1/16W	
L400			L92-0136-05	FERRITE CHIP		R60			RK73GB1J680J	CHIP R 68 J 1/16W	
L401-403			L92-0138-05	FERRITE CHIP		R61			R92-1252-05	CHIP R 0 OHM	
X1		*	L77-1704-05	TCXO (16.8MHz)		R63			R92-1252-05	CHIP R 0 OHM	
X300		*	L77-1742-05	CRYSTAL RESONATOR (45.305MHz)		R65			RK73GB1J222J	CHIP R 2.2K J 1/16W	
X400			L78-0431-05	RESONATOR (14.7456MHz)		R69-71			RK73GB1J221J	CHIP R 220 J 1/16W	
X600			L77-1708-05	CRYSTAL RESONATOR (3.579545MHz)		R73			RK73GB1J223J	CHIP R 22K J 1/16W	
XF300		*	L71-0523-05	MCF (44.85MHz)		R74			RK73GB1J101J	CHIP R 100 J 1/16W	
XF301			L71-0502-05	MCF (44.85MHz)		R75			RK73GB1J102J	CHIP R 1.0K J 1/16W	
CP1			R90-0714-05	MULTI-COMP 10K X4		R76			RK73GB1J101J	CHIP R 100 J 1/16W	
						R77			RK73GB1J560J	CHIP R 56 J 1/16W	
						R79			RK73GB1J104J	CHIP R 100K J 1/16W	

TK-290

TX-RX UNIT (X57-5390-10)

Ref. No.	Address	New parts	Parts No.	Description	Destination	Ref. No.	Address	New parts	Parts No.	Description	Destination
R200			RK73GB1J473J	CHIP R 47K J 1/16W		R421			RK73GB1J223J	CHIP R 22K J 1/16W	
R201			RK73GB1J104J	CHIP R 100K J 1/16W		R422			RK73GB1J103J	CHIP R 10K J 1/16W	
R202			RK73GB1J274J	CHIP R 270K J 1/16W		R423			RK73GB1J473J	CHIP R 47K J 1/16W	
R203			RK73GB1J560J	CHIP R 56 J 1/16W		R424			RK73GB1J103J	CHIP R 10K J 1/16W	
R204			RK73GB1J271J	CHIP R 270 J 1/16W		R425			R92-1252-05	CHIP R 0 OHM	
R205			RK73GB1J104J	CHIP R 100K J 1/16W		R426			RK73GB1J103J	CHIP R 10K J 1/16W	
R206			RK73GB1J473J	CHIP R 47K J 1/16W		R428			RK73GB1J472J	CHIP R 4.7K J 1/16W	
R207			R92-1252-05	CHIP R 0 OHM		R429			RK73GB1J103J	CHIP R 10K J 1/16W	
R208			RK73GB1J122J	CHIP R 1.2K J 1/16W		R430			RK73GB1J473J	CHIP R 47K J 1/16W	
R209			RK73GB1J100J	CHIP R 10 J 1/16W		R432,433			RK73GB1J473J	CHIP R 47K J 1/16W	
R210,211			RK73GB1J104J	CHIP R 100K J 1/16W		R434			RK73GB1J103J	CHIP R 10K J 1/16W	
R212			RK73GB1J222J	CHIP R 2.2K J 1/16W		R435,436			RK73GB1J102J	CHIP R 1.0K J 1/16W	
R213			RK73GB1J271J	CHIP R 270 J 1/16W		R438-440			RK73GB1J102J	CHIP R 1.0K J 1/16W	
R214			RK73GB1J101J	CHIP R 100 J 1/16W		R442			RK73GB1J152J	CHIP R 1.5K J 1/16W	
R215,216			R92-1252-05	CHIP R 0 OHM		R443			RK73GB1J681J	CHIP R 680 J 1/16W	
R219			R92-1252-05	CHIP R 0 OHM		R444			R92-0670-05	CHIP R 0 OHM	
R222			R92-1252-05	CHIP R 0 OHM		R445			R92-1252-05	CHIP R 0 OHM	
R226			R92-1252-05	CHIP R 0 OHM		R446			RK73GB1J472J	CHIP R 4.7K J 1/16W	
R300			RK73GB1J220J	CHIP R 22 J 1/16W		R447			RK73GB1J473J	CHIP R 47K J 1/16W	
R301			RK73GB1J122J	CHIP R 1.2K J 1/16W		R448			RK73GB1J102J	CHIP R 1.0K J 1/16W	
R303,304			RK73GB1J472J	CHIP R 4.7K J 1/16W		R449,450			RK73GB1J473J	CHIP R 47K J 1/16W	
R305,306			R92-1252-05	CHIP R 0 OHM		R452-455			RK73GB1J104J	CHIP R 100K J 1/16W	
R307,308			RK73GB1J221J	CHIP R 220 J 1/16W		R456-460			RK73GB1J473J	CHIP R 47K J 1/16W	
R309,310			RK73GB1J472J	CHIP R 4.7K J 1/16W		R463,464			RK73GB1J473J	CHIP R 47K J 1/16W	
R312			RK73GB1J122J	CHIP R 1.2K J 1/16W		R465			RK73GB1J104J	CHIP R 100K J 1/16W	
R313			RK73GB1J331J	CHIP R 330 J 1/16W		R466			R92-1252-05	CHIP R 0 OHM	
R315			RK73GB1J472J	CHIP R 4.7K J 1/16W		R467,468			RK73GB1J473J	CHIP R 47K J 1/16W	
R317,318			RK73GB1J223J	CHIP R 22K J 1/16W		R470-472			R92-1252-05	CHIP R 0 OHM	
R319			RK73GB1J123J	CHIP R 12K J 1/16W		R474			RK73GB1J103J	CHIP R 10K J 1/16W	
R320			RK73GB1J392J	CHIP R 3.9K J 1/16W		R475-477			RK73GB1J101J	CHIP R 100 J 1/16W	
R321			RK73GB1J102J	CHIP R 1.0K J 1/16W		R481			R92-1252-05	CHIP R 0 OHM	
R322			RK73GB1J272J	CHIP R 2.7K J 1/16W		R601			RK73GB1J153J	CHIP R 15K J 1/16W	
R324,325			RK73GB1J223J	CHIP R 22K J 1/16W		R602			RK73GB1J223J	CHIP R 22K J 1/16W	
R326			RK73GB1J473J	CHIP R 47K J 1/16W		R603			R92-1252-05	CHIP R 0 OHM	
R328			RK73GB1J472J	CHIP R 4.7K J 1/16W		R605,606			R92-1252-05	CHIP R 0 OHM	
R329			RK73GB1J104J	CHIP R 100K J 1/16W		R607			RK73GB1J153J	CHIP R 15K J 1/16W	
R330			R92-1252-05	CHIP R 0 OHM		R608			RK73GB1J103J	CHIP R 10K J 1/16W	
R331			RK73GB1J104J	CHIP R 100K J 1/16W		R609			RK73GB1J154J	CHIP R 150K J 1/16W	
R332			RK73GB1J224J	CHIP R 220K J 1/16W		R610			RK73GB1J563J	CHIP R 56K J 1/16W	
R333			R92-1252-05	CHIP R 0 OHM		R611			RK73GB1J184J	CHIP R 180K J 1/16W	
R334			RK73GB1J100J	CHIP R 10 J 1/16W		R612			RK73GB1J334J	CHIP R 330K J 1/16W	
R335			RK73GB1J473J	CHIP R 47K J 1/16W		R614			RK73GB1J184J	CHIP R 180K J 1/16W	
R336,337			R92-1252-05	CHIP R 0 OHM		R615,616			RK73GB1J103J	CHIP R 10K J 1/16W	
R400			RK73GB1J102J	CHIP R 1.0K J 1/16W		R617			R92-1252-05	CHIP R 0 OHM	
R401			RK73GB1J272J	CHIP R 2.7K J 1/16W		R618			RK73GB1J683J	CHIP R 68K J 1/16W	
R402			RK73GB1J332J	CHIP R 3.3K J 1/16W		R620			RK73GB1J334J	CHIP R 330K J 1/16W	
R403			RK73GB1J473J	CHIP R 47K J 1/16W		R621			RK73GB1J683J	CHIP R 68K J 1/16W	
R404			RK73GB1J182J	CHIP R 1.8K J 1/16W		R622			RK73GB1J223J	CHIP R 22K J 1/16W	
R405			RK73GB1J332J	CHIP R 3.3K J 1/16W		R623			RK73GB1J334J	CHIP R 330K J 1/16W	
R407			RK73GB1J102J	CHIP R 1.0K J 1/16W		R624			RK73GB1J273J	CHIP R 27K J 1/16W	
R408			RK73GB1J104J	CHIP R 100K J 1/16W		R625			RK73GB1J333J	CHIP R 33K J 1/16W	
R409			RK73GB1J102J	CHIP R 1.0K J 1/16W		R626			RK73GB1J104J	CHIP R 100K J 1/16W	
R410			RK73GB1J272J	CHIP R 2.7K J 1/16W		R627			RK73GB1J684J	CHIP R 680K J 1/16W	
R411			RK73GB1J821J	CHIP R 820 J 1/16W		R628			RK73GB1J334J	CHIP R 330K J 1/16W	
R412			RK73GB1J182J	CHIP R 1.8K J 1/16W		R629			RK73GB1J223J	CHIP R 22K J 1/16W	
R413			RK73GB1J473J	CHIP R 47K J 1/16W		R632			RK73GB1J103J	CHIP R 10K J 1/16W	
R414			R92-1252-05	CHIP R 0 OHM		R635			RK73GB1J393J	CHIP R 39K J 1/16W	
R415			RK73GB1J471J	CHIP R 470 J 1/16W		R637			R92-1252-05	CHIP R 0 OHM	
R416,417			RK73GB1J104J	CHIP R 100K J 1/16W		R638			RK73GB1J472J	CHIP R 4.7K J 1/16W	
R420			RK73GB1J103J	CHIP R 10K J 1/16W		R639			RK73GB1J104J	CHIP R 100K J 1/16W	

TX-RX UNIT (X57-5390-10)

Ref. No.	Address	New parts	Parts No.	Description	Destination	Ref. No.	Address	New parts	Parts No.	Description	Destination
R640			RN73GH1J683D	CHIP R 68K D 1/16W		IC3		*	M62354GP	IC (D/A CONVERTER)	
R641			RK73GB1J104J	CHIP R 100K J 1/16W		IC4		*	MAX865	IC (DC/DC CONVERTER)	
R642			RN73GH1J333D	CHIP R 33K D 1/16W		IC5			SA7025DK	IC (PLL SYSTEM)	
R643			RK73GB1J564J	CHIP R 560K J 1/16W		IC6			LMC7101BIM5	IC (OP AMP)	
R644			RK73GB1J474J	CHIP R 470K J 1/16W		IC7			NJM2904V	IC (APC)	
R645			RN73GH1J274D	CHIP R 270K D 1/16W		IC10		*	KCH40	HIC (VCO)	
R646			RK73GB1J472J	CHIP R 4.7K J 1/16W		IC200		*	GN2011(Q)	IC	
R647			R92-1252-05	CHIP R 0 OHM		IC300			TA31136FN	IC (FM IF DETECTOR)	
R648			RK73GB1J104J	CHIP R 100K J 1/16W		IC301			TC7S66FU	IC (ANALOG SWITCH)	
R649			RN73GH1J682D	CHIP R 6.8K D 1/16W		IC400			BU4094BCFV	IC (8bit SHIFT/STORE REGISTER)	
R650			RK73GB1J103J	CHIP R 10K J 1/16W		IC401,402			TK11250BM	IC (VOLTAGE REGULATOR)	
R651			RK73GB1J155J	CHIP R 1.5M J 1/16W		IC403-405			BU4094BCFV	IC (8bit SHIFT/STORE REGISTER)	
R652			RK73GB1J473J	CHIP R 47K J 1/16W		IC406		*	MC-8800-802	IC (MICRO PROCESSOR)	
R653			RK73GB1J184J	CHIP R 180K J 1/16W		IC407			RN5VL45C	IC (REGULATOR)	
R654			RN73GH1J683D	CHIP R 68K D 1/16W		IC408			TC7S08FU	IC (2INPUT AND GATE)	
R655			RK73GB1J474J	CHIP R 470K J 1/16W		IC409			PST9140NR	IC (RESET SW)	
R656			RN73GH1J682D	CHIP R 6.8K D 1/16W		IC410			TC7S32FU	IC (2INPUT OR GATE)	
R657			RK73GB1J101J	CHIP R 100 J 1/16W		IC411			TC7S02FU	IC (2 INPUT NOR GATE)	
R658			RK73GB1J224J	CHIP R 220K J 1/16W		IC412			AT2408N10SI2.5	IC (8kbit SERIAL EEPROM)	
R659			RK73GB1J103J	CHIP R 10K J 1/16W		IC413			TA75S01F	IC (OP AMP)	
R660			RK73GB1J223J	CHIP R 22K J 1/16W		IC600			LC73872M	IC (DTMF RECEIVER)	
R661			RK73GB1J394J	CHIP R 390K J 1/16W		IC601			TC75W51FU	IC (OP AMP X2)	
R662			RK73GB1J470J	CHIP R 47 J 1/16W		IC602			TA75W01FU	IC (OP AMP X2)	
R663			RK73GB1J220J	CHIP R 22 J 1/16W		IC603			M62364FP	IC (D/A CONVERTER)	
R664			RK73GB1J333J	CHIP R 33K J 1/16W		IC604-606			TC75W51FU	IC (OP AMP X2)	
R665-666			R92-1252-05	CHIP R 0 OHM		IC607			TC35453F	IC (AUDIO PROCESSOR)	
R668			RK73GB1J334J	CHIP R 330K J 1/16W		Q1			DTA114EE	DIGITAL TRANSISTOR	
R669			R92-1252-05	CHIP R 0 OHM		Q2			2SJ144(GR)	FET	
R670-673			RK73GB1J472J	CHIP R 4.7K J 1/16W		Q3			2SC4619(P,Q)	TRANSISTOR	
R674			RK73GB1J104J	CHIP R 100K J 1/16W		Q4			2SC4617(S)	TRANSISTOR	
R675			RK73GB1J473J	CHIP R 47K J 1/16W		Q5			2SC4619(P,Q)	TRANSISTOR	
R676			RK73GB1J684J	CHIP R 680K J 1/16W		Q6			2SC5110(O)	TRANSISTOR	
R677			RK73GB1J333J	CHIP R 33K J 1/16W		Q7			DTC114EE	DIGITAL TRANSISTOR	
R678			RK73GB1J184J	CHIP R 180K J 1/16W		Q8			2SC4988	TRANSISTOR	
R700			RK73HB1J100J	CHIP R 10 J 1/16W		Q9			DTA144EE	DIGITAL TRANSISTOR	
R701,702			RK73HB1J102J	CHIP R 1.0K J 1/16W		Q10			DTC144EE	DIGITAL TRANSISTOR	
R703-705			RK73HB1J100J	CHIP R 10 J 1/16W		Q11			DTC114YE	DIGITAL TRANSISTOR	
R706			RK73HB1J102J	CHIP R 1.0K J 1/16W		Q12			DTA143EE	DIGITAL TRANSISTOR	
R707			R92-1368-05	CHIP R 0 OHM		Q13			2SK1824	FET	
R708,709			RK73HB1J102J	CHIP R 1.0K J 1/16W		Q200			3SK274	FET	
R710			RK73HB1J100J	CHIP R 10 J 1/16W		Q300			DTA144EE	DIGITAL TRANSISTOR	
R711-716			RK73HB1J102J	CHIP R 1.0K J 1/16W		Q301			DTC144EE	DIGITAL TRANSISTOR	
D4			MA2S111	DIODE		Q302			2SK1215(E)	FET	
D5			DAN235E	DIODE		Q303			DTA144EE	DIGITAL TRANSISTOR	
D6			MA2S111	DIODE		Q304			DTC144EE	DIGITAL TRANSISTOR	
D7			DAN235E	DIODE		Q305			UMC4	TRANSISTOR	
D8			DA221	DIODE		Q307			UMH6	TRANSISTOR	
D9			MA8062	ZENER DIODE		Q400			UMG3N	TRANSISTOR	
D10			MI809	DIODE		Q401			UPA572T	FET	
D11			1SS312	DIODE		Q402			MP5A02	TRANSISTOR	
D200			HSM88AS	DIODE		Q403			2SJ243	FET	
D201-208			1SV273	VARIABLE CAPACITANCE DIODE		Q404			DTC144EE	DIGITAL TRANSISTOR	
D300-303			DAN235E	DIODE		Q405			UMG3N	TRANSISTOR	
D400			1SR154-400	DIODE		Q406			DTA123JE	DIGITAL TRANSISTOR	
D401			MA2S111	DIODE		Q407			2SC4215(V)	TRANSISTOR	
D402,403			NNCD6.8G	ZENER DIODE		Q408-410			2SC4617(S)	TRANSISTOR	
D409			MA2S111	DIODE		Q411			2SB1132(Q,R)	TRANSISTOR	
D601			MA742	DIODE		Q600			DTC144EE	DIGITAL TRANSISTOR	
IC2			LMC7101BIM5	IC (OP AMP)		Q601-603			2SK1824	FET	

PACKING

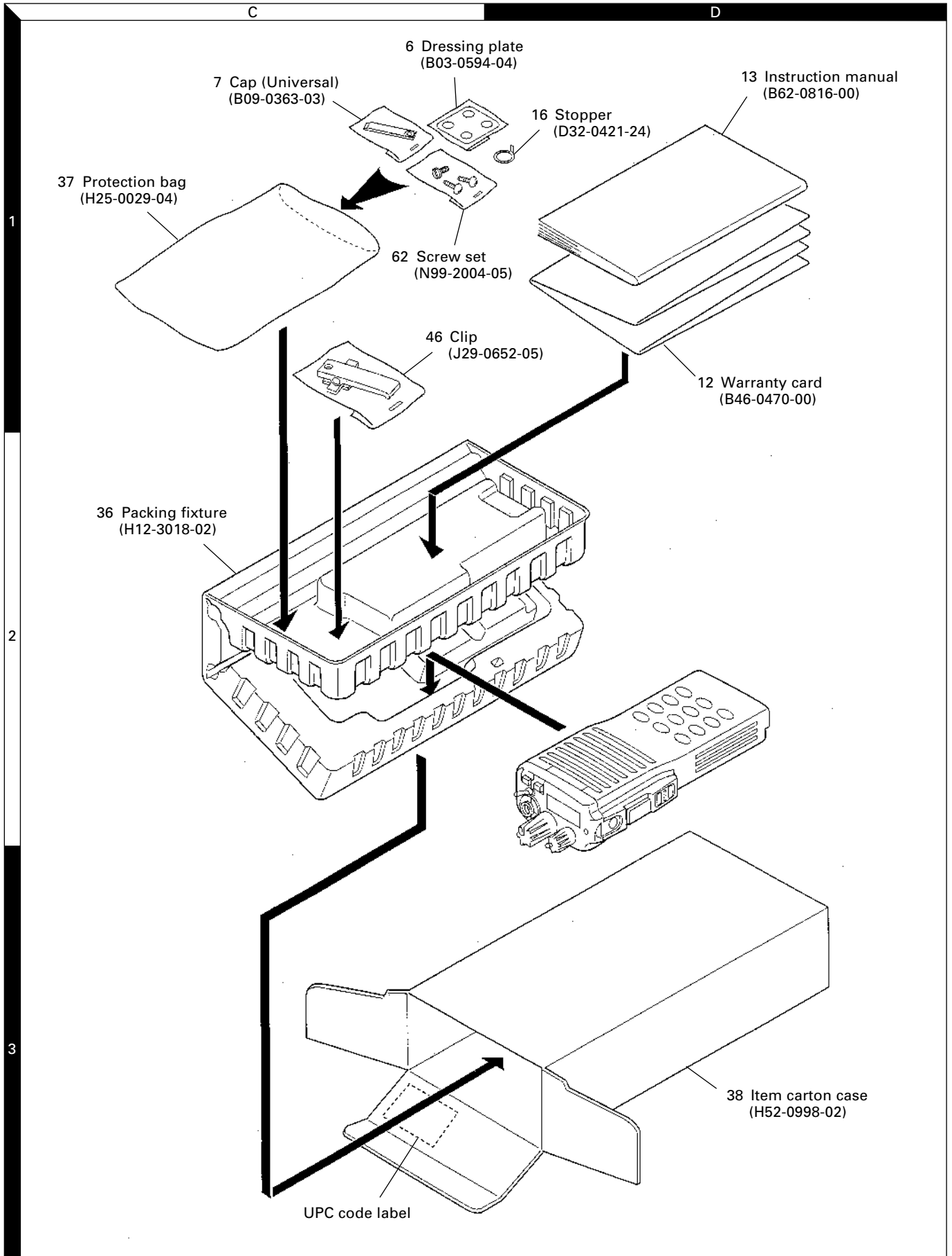

DISASSEMBLY FOR REPAIR

Disassembly of Front Case and Chassis

1. Remove the 2 screws (1) and a cap fixed screw (2).
2. Press the chassis bottom upwards and remove the clips (3) at the top. The front case is still connected to the chassis by the FPC at this time so be gentle when lifting upwards, otherwise unwanted stress is applied on the FPC.
3. The front case and chassis can only be opened to the side when connected by the FPC (4).

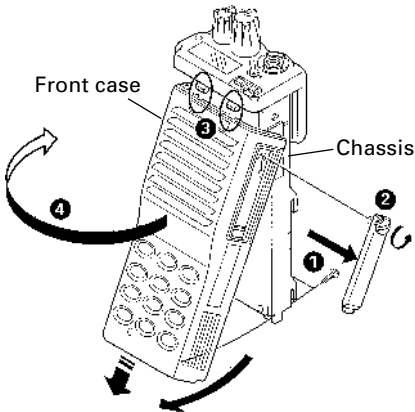

Remove the Side Key Assy

1. The side key assy is clips form a slide-hook structure. Lift up gently and take from the side (12).

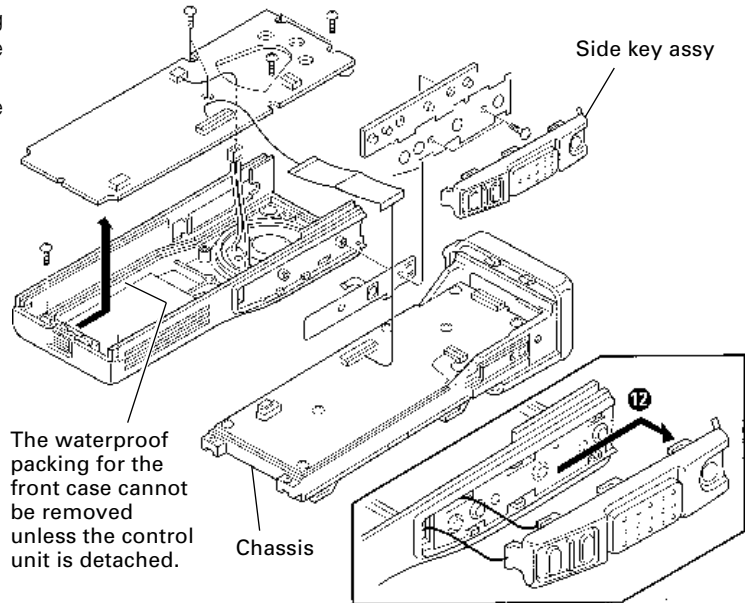

Remove the TX-RX Unit from the Chassis

1. The TX-RX unit cannot be removed simply by removing the seven screws (5).
2. A total of 9 solder connections, 6 on the RF power module (6) and 3 on the antenna daughter board (7) must be disconnected.

Remove the Universal Connector

1. The universal connector (8) is fastened to the chassis with double-side tape.
2. First unsolder the connection on the antenna daughter board (9).
3. Press firmly with a tool such as a screwdriver and so that it can peel (10).

Note : You must replace both parts together when replacing the universal connector or the FPC (11).

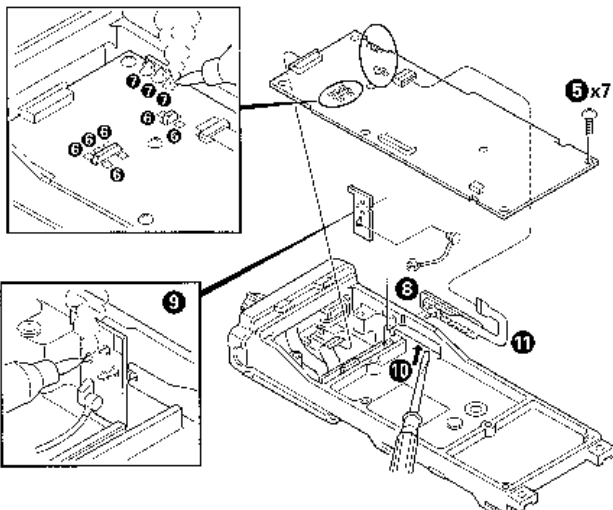

Disassembly of the Panel Assy

1. The LCD assy and toggle switch are joined by wire (13). Use caution not to break this wire during handling.

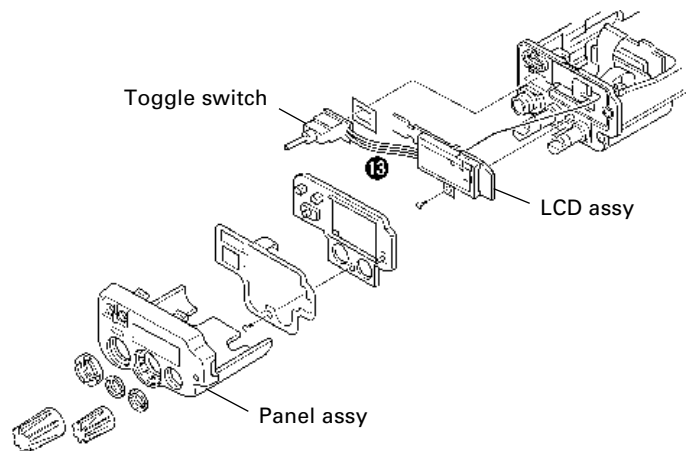

ADJUSTMENT

Test Equipment Required for Alignment

No.	Test Equipment	Major Specifications	
1	Standard Signal Generator (SSG)	Frequency Range Modulation Output	Maximum 600MHz or more. Frequency modulation and external modulation. -133dBm/0.05 μ V to 7dBm/501mV
2	Power Meter	Input Impedance Operation Frequency Measurement Range	50 Ω . Up to 600MHz. Full scale of 10W or so.
3	Deviation Meter	Frequency Range	100 to 200MHz.
4	Digital Volt Meter (DVM)	Measuring Range Accuracy	FS=18V or so. High input impedance for minimum circuit loading.
5	Oscilloscope		DC through 30MHz.
6	High Sensitivity Frequency Counter	Frequency Range Frequency Stability	Up to 1GHz or so. 0.2ppm or less.
7	Ammeter		5A.
8	AF Volt Meter (AF VTVM)	Frequency Range Voltage Range	50Hz to 1MHz. 1mV to 10V.
9	Audio Generator (AG)	Frequency Range Output	100Hz to 100kHz or more. 0 to 1V.
10	Distortion Meter	Capability Input Level	3% or less at 1kHz. 50mV to 10Vrms.
11	16 Ω Dummy Load		Approx. 16 Ω , 5W.
12	Regulated Power Supply		5V to 10V, approx. 5A Useful if ammeter equipped.
13	Spectrum Analyzer	Measuring Range	DC to 1GHz or more.
14	Tracking Generator	Center Frequency Frequency Deviation Output Voltage	50kHz to 600MHz. \pm 35MHz. 100mV or more.

■ The following parts are required for adjustment

1. Antenna connector adapter

The antenna connector of this radio uses an SMA terminal.

Use an antenna connector adapter [SMA(f) – BNC(f) or SMA(f) – N(f)] for adjustment. (The adapter is not provided as an option, so buy a commercially-available one.)

Note

When the antenna connector adapter touches the knob, draw out the knob to mount the connector.

2. Universal connector

Use the interface cable (KPG-36) for PC tuning or the lead wire with plug (E30-3287-08) and screw (N08-0535-08) for panel tuning. Connect the plug to the universal connector of the radio and tighten the screw.

The lead wire with plug (E30-3287-08) and screw (N08-0535-08) terminals are as follows. Numbers are universal connector terminal numbers.

Caution

- When connecting the plug to the universal connector of the radio, a short circuit may occur. To prevent this, be sure to turn the radio POWER switch off.
- Since the RX AF output is a BTL output, there is a DC component. Isolate this with a capacitor or transformer as shown in the figure.
- Do not connect an instrument between red or black and GND.

• Universal connector

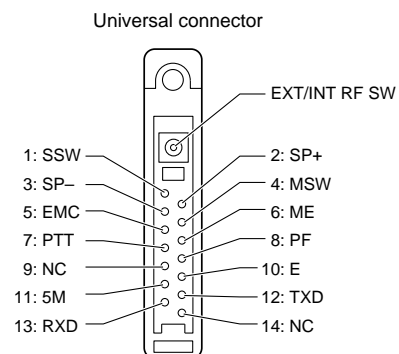

ADJUSTMENT

• Panel tuning

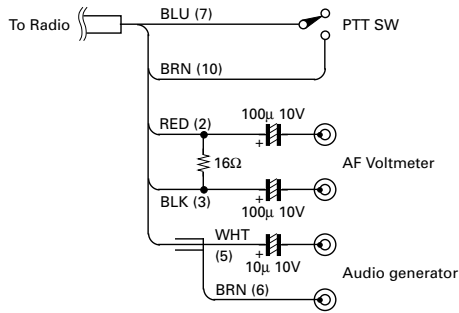
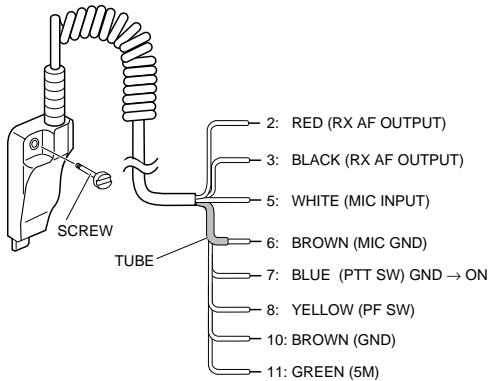

• PC tuning

Connect the wires to the PCB in the connector case of interface cable.

For output the wires out of the connector case, need to process the connector case.

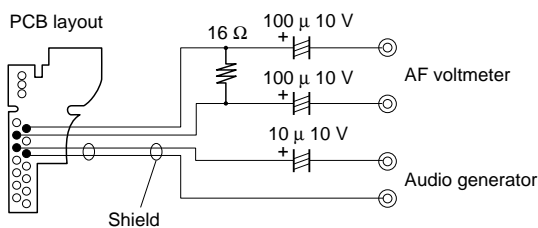
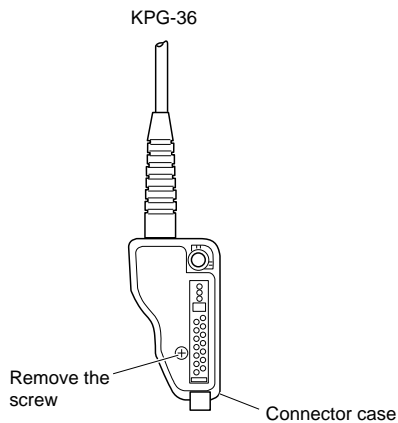

Repair Jig (Chassis)

Use jig (part No.: A10-1399-03) for repairing the TK-290. Place the TX-RX unit on the jig and fit it with 7 screws.

Note : Supply power from an external power supply (Battery terminal : +, jig (chassis) : -)

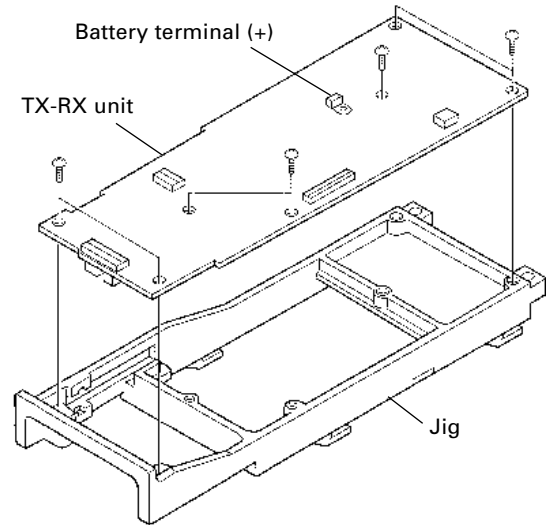

How to Remove the Flat Cable

1. Gently draw out both sides of the connector lever uniformly in the direction of the arrow with tweezers. (CN101, CN400)

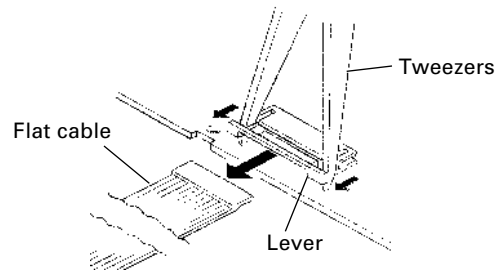

2. Gently rise up the connector lever in the direction of the arrow with a fine regular screwdriver or tweezers. (CN1, CN3, CN401, CN403)

Note : Gently push both sides of the connector lever, when put in the flat cable.

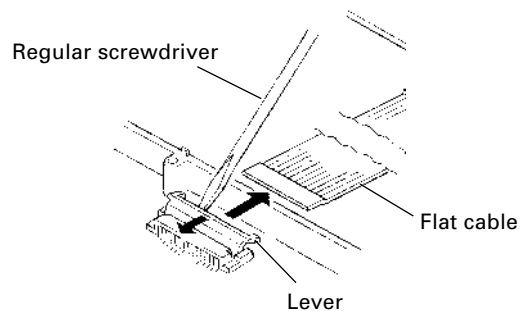

ADJUSTMENT

Panel Test Mode

This mode is used for making transceiver connection tests and clearing the memory.

To set Panel test mode, turn on the power with [Side 2] and [PTT] are still held down and then first release [PTT]. This mode cannot be set when disabled with the FPU.

In Panel test mode, when channel or signalling is selected, the signalling that was most recently used is displayed.

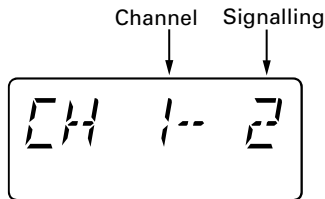

Key operations in Panel test mode are as follows.

- [Selector switch] : Use to select the test channel.
- [PTT] : For transmit.
- [Top 1] : For down signalling.
- [Top 2] : For up signalling.
- [Side 1] : For setting Panel tuning mode.
- [Side 2] : For switching power between Hi/Low.
Enter the LCD all lamp mode if held down for 2 seconds.
- [Orange] : For monitoring.
- [Toggle] : For switching between Wide/Narrow.

Frequency (MHz)

CH	RX	TX
1	155.1000 (Center)	155.0000 (Center)
2	136.1000 (Low)	136.0000 (Low)
2	173.9000 (Hi)	173.9750 (Hi)
4	155.0000	155.0000
5	155.2000	155.2000
6	155.4000	155.4000

Signalling

No.	Encode tone	Decode tone
1	None	None
2	QT 67.0Hz	QT 67.0Hz
3	QT 250.3Hz	QT 25.03Hz
4	DQT 023N	DQT 023N
5	None	2 tone 321.7/928.1Hz
6	DTMF (9)	DTMF (159)
7	MSK PN pattern	None
8	100Hz square wave	None
9	Single tone 1633Hz	None

LCD all lamp mode

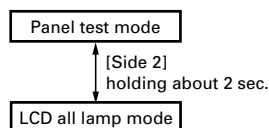

Clear function

Pressing [PTT] while holding down [Orange] in Panel test mode, triggers the clear function which clears all transceiver data settings.

Panel tuning mode

Press [Side 1] in Panel test mode to set Panel tuning mode.

Note : Different sample displays are shown.

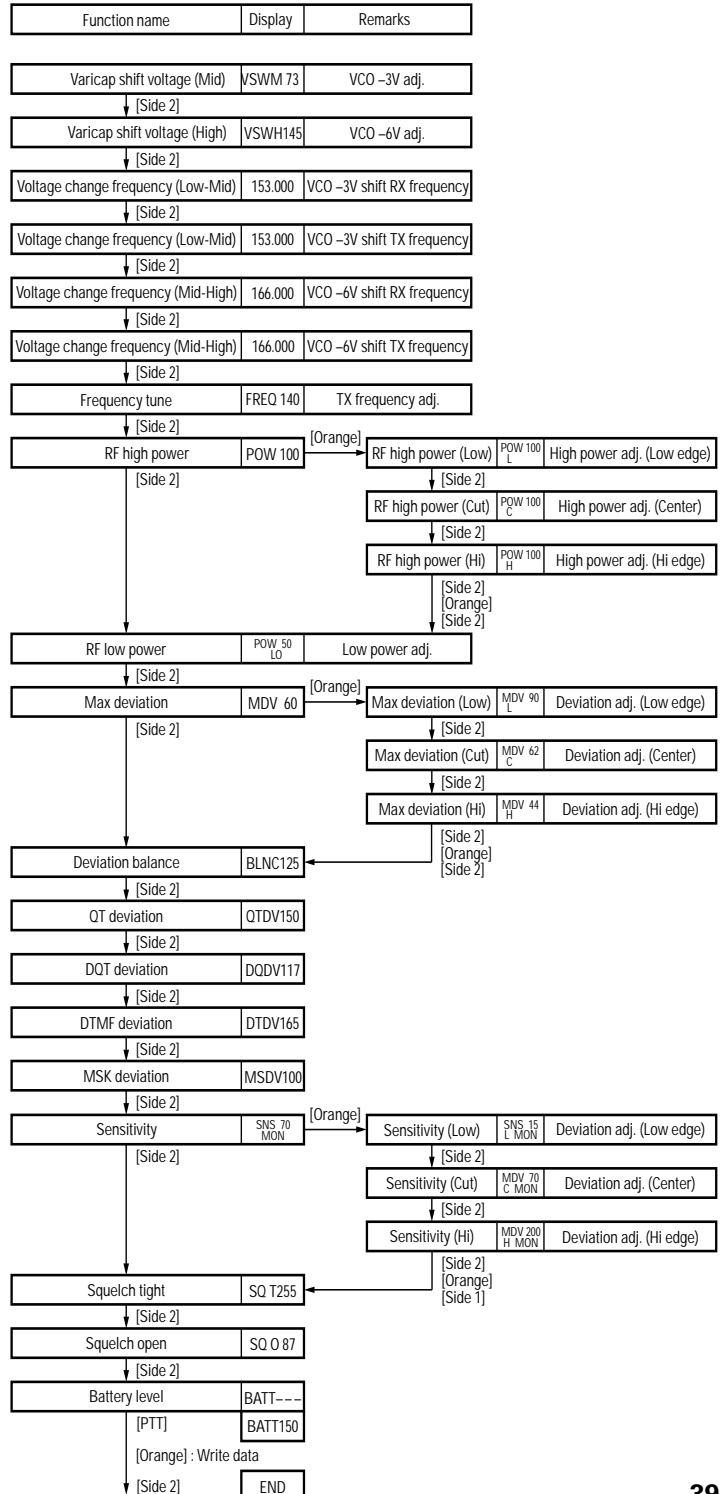

TK-290

Common Section

Item	Condition	Measurement			Adjustment			Specifications/Remarks
		Test-equipment	Unit	Terminal	Unit	Parts	Method	
1. Varicap shift voltage	1) Set panel tuning mode Push Side2 to select VSWM * *	DC VTVM	TX-RX	TP2	Panel	Top1/ Top2	-3V	±0.1V
Mid	2) Push Side2 to select VSWH * * *						-6V	±0.1V
High				TP1			4.15V	±0.05V
2. Voltage change frequency	1) Set panel tuning mode Push Side2 to select * * * . * * *						4.15V	±0.05V
Low-Mid RX	2) Push Side2 to select * * * . * * *	4.15V	±0.05V					
TX	3) Push Side2 to select * * * . * * *	4.15V	±0.05V					
Mid-Hi RX	4) Push Side2 to select * * * . * * *	4.15V	±0.05V					
TX	t2							

Caution : When adjusting transmit power and sensitivity, connect the cable to the SMA antenna connector on the top panel. At this time, use the antenna-less type jig connector (E30-3287-08) in the universal connector.

Transmitter Section

Item	Condition	Measurement			Adjustment			Specifications/Remarks
		Test-equipment	Unit	Terminal	Unit	Parts	Method	
1. Frequency adjustment	1) Set panel test mode CH No. : 3 Signalling No. : 1 Select FRQ * * * in panel tuning mode PTT : ON	Power meter f. counter	Panel	ANT	Panel	Top1/ Top2	155.100MHz	±50Hz
2. Maximum power check	1) Set panel test mode CH No. : 3 Signalling No. : 1 BATT terminal voltage : 7.5V Select POW 255 in panel tuning mode PTT : ON	Power meter Ammeter	Panel	ANT			Check	5.0W or more
3. TX high power adjustment	1) Set panel test mode CH No. : 3 Signalling No. : 1 Select POW * * * in tuning mode Push Orange to 3 point adjustment mode Select POW * * * L PTT : ON				Panel	Top1/ Top2	4.70W	±0.1W 2.3A or less
	2) Push Side2 to select POW * * * M PTT : ON							
	3) Push Side2 to select POW * * * H PTT : ON							

Item	Condition	Measurement			Adjustment			Specifications/Remarks
		Test-equipment	Unit	Terminal	Unit	Parts	Method	
4. TX high power check	1) Set panel test mode CH No. : 1 Signalling No. : 1 PTT : ON	Power meter	Panel	ANT			Check	3.7W~5.2W 2.3A or less
	2) CH No. : 3 Signalling No. : 1 PTT : ON	Ammeter						
	3) CH No. : 5 Signalling No. : 1 PTT : ON							
5. TX low power adjustment	1) Set panel test mode CH No. : 3 Signalling No. : 1 Select POW * * * LO in panel tuning mode Push Orange to 3 point adjustment mode Select POW * * * L LO PTT : ON				Panel	Top1/ Top2	1.0W	±0.1W 1.2A or less
	2) Push Side2 to select POW * * * M LO PTT : ON							
	3) Push Side2 to select POW * * * H LO PTT : ON							
6. TX low power check	1) Set panel test mode CH No. : 1 Signalling No. : 1 Set low power (Push Top2) PTT : ON						Check	0.5W~1.5W 1.2A or less
	2) CH No. : 3 Signalling No. : 1 Set low power (Push Top2) PTT : ON							
	3) CH No. : 5 Signalling No. : 1 Set low power (Push Top2) PTT : ON							
7. DQT balance adjustment	1) Set panel test mode CH No. : 3 Signalling No. : 1 Select BLNC * * * in panel tuning mode Deviation meter filter setting LPF : 3kHz HPF : OFF PTT : ON	Power meter Deviation meter Oscilloscope AG AF VTVM	Panel Side	ANT Universal	Panel	Top1/ Top2	Make the demodulation waves into square waves.	

TK-290

Item	Condition	Measurement			Adjustment			Specifications/Remarks
		Test-equipment	Unit	Terminal	Unit	Parts	Method	
8. Maximum deviation adjustment (Wide)	1) Set panel test mode CH No. : 3 Signalling No. : 1 Select MDV * * * in panel tuning mode Push Orange to 3 point adjustment mode Select MDV * * * L AG : 1kHz/150mV Deviation meter filter setting LPF : 15kHz HPF : OFF PTT : ON	Power meter Deviation meter Oscilloscope	Panel	ANT	Panel	Top1/ Top2	3.95kHz (According to the larger +, -)	±50Hz
	2) Push Side2 to select POW * * * M PTT : ON	AG	Side	Universal				
	3) Push Side2 to select POW * * * H PTT : ON	AF VTVM						
9. Maximum deviation adjustment (narrow)	1) Set panel test mode CH No. : 3 Signalling No. : 1 Select MDV * * * in panel tuning mode Turn the toggle SW to the right (narrow). Push Orange to 3 point adjustment mode Select MDV * * * N L AG : 1kHz/150mV Deviation meter filter setting LPF : 15kHz HPF : OFF PTT : ON						1.90kHz (According to the larger +, -)	±50Hz
	2) Push Side2 to select POW * * * N M PTT : ON							
	3) Push Side2 to select POW * * * N H PTT : ON							
10. MIC sensitivity check	1) Set panel test mode CH No. : 3 Signalling No. : 1 AG : 1kHz/15mV Deviation meter filter setting LPF : 15kHz HPF : OFF PTT : ON						Check	1.8kHz~3.6kHz
	2) Turn the toggle SW to the right (narrow) PTT : ON							0.9kHz~1.8kHz

Item	Condition	Measurement			Adjustment			Specifications/Remarks
		Test-equipment	Unit	Terminal	Unit	Parts	Method	
11. QT deviation adjustment (wide)	1) Set panel tuning mode CH No. : 3 Signalling No. : 1 MIC input : OFF Select QTDV * * * in panel tuning mode Deviation meter filter setting LPF : 3kHz HPF : 50Hz De-emphasis : 750μs PTT : ON	Power meter Deviation meter Oscilloscope AG AF VTVM	Panel Side	ANT Universal	Panel	Top1/ Top2	0.75kHz	±0.05kHz
12. QT deviation adjustment (narrow)	1) Set panel tuning mode CH No. : 3 Signalling No. : 1 MIC input : OFF Select QTDV * * * in panel tuning mode Turn the toggle SW to the right (narrow) Deviation meter filter setting LPF : 3kHz HPF : 50Hz De-emphasis : 750μs PTT : ON						0.375kHz	±0.05kHz
13. DQT deviation adjustment (wide)	1) Set panel test mode CH No. : 3 Signalling No. : 1 Select DQDV * * * in panel tuning mode Deviation meter filter setting LPF : 3kHz HPF : OFF PTT : ON						0.75kHz	±0.05kHz
14. DQT deviation adjustment (narrow)	1) Set panel tuning mode CH No. : 3 Signalling No. : 1 Select DQDV * * * in panel tuning mode Turn the toggle SW to the right (narrow) Deviation meter filter setting LPF : 3kHz HPF : OFF PTT : ON						0.375kHz	±0.05kHz
15. DTMF deviation adjustment (wide)	1) Set panel test mode CH No. : 3 Signalling No. : 1 Select DTDV * * * in tuning mode Deviation meter filter setting LPF : 15kHz HPF : OFF PTT : ON						3.0kHz	±50Hz

TK-290

Item	Condition	Measurement			Adjustment			Specifications/Remarks
		Test-equipment	Unit	Terminal	Unit	Parts	Method	
16. DTMF deviation adjustment (narrow)	1) Set panel tuning mode CH No. : 3 Signalling No. : 1 Select DTDV * * * in panel tuning mode Turn the toggle SW to the right (narrow) Deviation meter filter setting LPF : 15kHz HPF : OFF PTT : ON	Power meter Deviation meter Oscilloscope AG AF VTVM	Panel Side	ANT Universal	Panel	Top1/ Top2	1.5kHz	±50Hz
							3.00kHz	±50Hz
							1.50kHz	±50Hz
17. MSK deviation adjustment (wide)	1) Set panel test mode CH No. : 3 Signalling No. : 1 Select MSDV * * * in panel tuning mode Deviation meter filter setting LPF : 15kHz HPF : OFF PTT : ON							
18. MSK deviation adjustment (narrow)	1) Set panel tuning mode CH No. : 3 Signalling No. : 1 Select MSDV * * * in panel tuning mode Turn the toggle SW to the right (narrow) Deviation meter filter setting LPF : 15kHz HPF : OFF PTT : ON							
19. Transmission S/N check (wide)	1) Set panel test mode CH No. : 3 Signalling No. : 1 Deviation meter filter setting LPF : 300Hz HPF : 3kHz De-emphasis : 750µs PTT : ON						Check	42dB or more
20. Transmission S/N check (narrow)	1) Set panel test mode CH No. : 3 Signalling No. : 1 Turn the toggle SW to the right (narrow) Deviation meter filter setting LPF : 300Hz HPF : 3kHz De-emphasis : 750µs PTT : ON							37dB or more
21. BATT detection writing	1) Set panel test mode CH No. : 3 Signalling No. : 1 Select BATT * * * in panel tuning mode PTT : ON	Power meter DC VTVM	Panel Bottom	ANT BATT terminal	Side	Orange	Write the voltage level	6.2V

Item	Condition	Measurement			Adjustment			Specifications/Remarks
		Test-equipment	Unit	Terminal	Unit	Parts	Method	
22. BATT detection check	1) Set panel test mode CH No. : 3 Signalling No. : 1 BATT terminal voltage : 5.7V PTT : ON	Power meter	Panel	ANT			Check	Cannot transmit LED (TX) blinks
	2) BATT terminal voltage : 6.5V PTT : ON	DC VTVM	Bottom	BATT terminal				Transmit

Receiver Section

Item	Condition	Measurement			Adjustment			Specifications/Remarks
		Test-equipment	Unit	Terminal	Unit	Parts	Method	
1. AF level check	1) Set panel test mode CH No. : 3 Signalling No. : 1 SSG freq. : Each freq. output : -53dBm/501µV MOD. : 1kHz DEV. : 3kHz	SST	Panel	ANT			Check	0.63V±0.3V 3% or less
	2) Turn the toggle SW to the right (narrow) SSG freq. : Each freq. output : -53dBm/501µV MOD. : 1kHz DEV. : 1.5kHz	AF VTVM Oscilloscope Distortion meter Audio analyzer						0.63V±0.3V 5% or less
2. Hum and noise ratio check	1) Set panel test mode CH No. : 3 Signalling No. : 1 SSG output : -53dBm/501µV							42dB or more
	2) Turn the toggle SW to the right (narrow) SSG output : -53dBm/501µV							37dBm
3. BPF coil Use this adjustment procedure after replacing any of the BPF coils	1) Set panel test mode CH No. : 1 Connect the spectrum analyzer to TP3 Signalling No. : 1 Push Orange to 3 point adjustment mode Select SNS 70 M	Tracking generator Spectrum analyzer	Panel TX-RX	ANT TP3	TX-RX	L201 L202 L205 L206	Adjust the BPF coil so that the waveform is peaked. The frequency with the peak waveform does not have to be the center frequency. After finished peaking the waveform, perform a 3 point adjustment and set for maximum sensitivity.	<p>RX BPF 010.011 REF -10.0dBm ATT 10dB A write B blank 10dB/</p> <p>Center 155.4MHz ΔMKR 155.4MHz -27.20dBm</p> <p>TG LEVEL -30dBm Low Hi</p> <p>RBW 100kHz VBW 10kHz SWP 200ms</p> <p>CENTER 155.0MHz SPAN 100.0MHz</p>

Item	Condition	Measurement			Adjustment			Specifications/Remarks
		Test-equipment	Unit	Terminal	Unit	Parts	Method	
4. Sensitivity adjustment and check (wide)	1) Set panel test mode CH No. : 3 Signalling No. : 1 Select SNS * * * in panel tuning mode Push Orange to 3 point adjustment mode Select SNS * * * L SSG freq. : Low output : -116dBm/0.35μV	SSG AF VTVM Oscilloscope Distortion meter Audio analyzer	Panel Side	ANT Universal	Panel	Top1/ Top2	Adjust for maximum SINAD	12dB SINAD or more
	2) Push Side2 to select SNS * * * M SSG freq. : Center							
	3) Push Side2 to select SNS * * * H SSG freq. : Hi							
5. Sensitivity check (narrow)	1) Set panel test mode CH No. : 1 Signalling No. : 1 SSG output : -116dBm/0.35μV MOD. : 1kHz DEV. : 1.5kHz Turn the toggle SW to the right (narrow)					Check	12dB SINAD or more	
	2) Set panel test mode CH No. : 3 Signalling No. : 1 Turn the toggle SW to the right (narrow)							
	3) Set panel test mode CH No. : 5 Signalling No. : 1 Turn the toggle SW to the right (narrow)							
6. Tight squelch adjustment (wide)	1) Set panel test mode CH No. : 3 Signalling No. : 1 Select SQ T * * * in panel tuning mode				Panel	Top1/ Top2	Normally set to 110	
7. Tight squelch adjustment (narrow)	1) Set panel test mode CH No. : 3 Signalling No. : 1 Select SQ T * * * in panel tuning mode Turn the toggle SW to the right (narrow)							
8. Squelch adjustment (wide)	1) Set panel test mode CH No. : 3 Signalling No. : 1 Select SQ O * * * ϕ in panel tuning mode SSG output : 3dB below to 12dB SINAD level							

TERMINAL FUNCTION

CN No.	Pin No.	Name	I/O	Function					
TX-RX UNIT (X57-5390-10)									
CN400 for X53 (B/6)	1	CH D	I	CH switch data.					
	2	CH A	I	CH switch data.					
	3	CH C	I	CH switch data.					
	4	CH B	I	CH switch data.					
	5	E	-	GND.					
	6	VOL	I	Voltage level input for audio control.					
	7	5CM	-	5V.					
	8	B+	-	Power input after passing through the fuse.					
	9	B+	-	Power input after passing through the fuse.					
	10	SB	-	Power output after power switch.					
	11	SB	-	Power output after power switch.					
	12	TOGGLE	I	Normally : 5V, switched toggle when connected GND.					
	13	KEY2	I	Key input.					
	14	Q6	O	Key scan IC Q6 signal output.					
	15	Q7	O	Key scan IC Q7 signal output.					
	16	LCDCS	O	Chip select output for LCD driver.					
	17	CLK	O	Clock data output for LCD driver.					
	18	DAT	O	Data output for LCD driver.					
	19	LAMP	-	Backlight LED control. Normally : 0V, Lighting : 7.5V					
	20	TXLED	-	TX LED control. Normally : 0V, Lighting : 7.5V					
	21	BLED	-	Busy LED control. Normally : 0V, Lighting : 7.5V					
	22	5M	-	5V.					
CN401 for X53 (A/6)	1	TCONT	O	For optional board. (See page 22.)					
	2	OPPTT	O	For optional board. (See page 22.)					
	3	AMPSW	O	Audio AMP control switch output.					
	4	EXAFC	O	External speaker switch control.					
	5	INAFc	O	Internal speaker switch control.					
	6	KRS	O	Key scan IC reset output.					
	7	KCK	O	Key scan IC clock data output.					
	8	SOD	-	Not use.					
	9	KEY1	I	Key input.					
	10	KEY2	I	Key input.					
	11	LCS	-	Not use.					
	12	PTT	I	PTT signal input.					
	13	N/CSW	O	Noise canseler microphone switch output.					
	14	NC	-	Not use.					
	15	CLK	O	Clock data output.					
	16	DAT	O	Data output.					
	17	E	-	GND.					
	18	SB	-	Power output after power switch.					
	19	SB	-	Power output after power switch.					
	20	5M	-	5V.					
	21	MICE	-	MIC GND.					
	22	MIC	I	MIC signal input.					
	23	AF	O	Audio output.					
	24	AFE	-	Audio GND.					
	25	AFE	-	Audio GND.					
CN No.	Pin No.	Name	I/O	Function					
					26	SP+	I	BTL input + for external speaker.	
					27	SP-	I	BTL input - for external speaker.	
					28	MUTE	O	Audio mute signal output.	
					29	SD TO	O	For optional board.	
					30	MAN D	O	For optional board.	
					31	LAMP	O	Backlight LED control. Normally : 0V, Lighting : 7.5V	
					32	Q7	O	Key scan IC Q7 signal input.	
					33	Q6	O	Key scan IC Q6 signal input.	
					CN402	1	AFE	-	Audio GND.
						2	AFE	-	AUdio GND.
					CN403	1	SSW	I	EXT/INT speaker switch input.
						2	SP+	O	BTL output + for external speaker.
						3	SP-	O	BTL output - for external speaker.
4	MSW	I	EXT/INT MIC switch input.						
5	EMC	I	External microphone input.						
6	ME	-	External microphone GND.						
7	PTT	I	External PTT input.						
8	PF	I	Programmable function key input.						
9	NC	-	Not use.						
10	E	-	GND.						
11	5M	-	5V.						
12	TXD	O	Serial data output.						
13	RXD	I	Serial data input.						
14	NC	-	Not use.						
CONTROL UNIT (X53-3780-XX) (A/6)									
CN1 for X57	1	Q6	O	Key scan IC Q6 output.					
	2	Q7	O	Key scan IC Q7 output.					
	3	LAMP	I	Backlight LED control. Normally : 0V, Lighting : 7.5V					
	4	MAN D	I	For optional board. (See page 22.)					
	5	SD TO	I	For optional board. (See page 22.)					
	6	MUTE	I	Audio mute signal input.					
	7	SP-	O	BTL output - for external speaker.					
	8	SP+	O	BTL output + for external speaker.					
	9	AFE	-	Audio GND.					
	10	AFE	-	Audio GND.					
	11	AF	I	Audio output.					
	12	MIC	O	MIC signal input.					
	13	MICE	-	MIC GND.					
	14	5M	-	5V.					
	15	SB	-	Power output after power switch.					
	16	SB	-	Power output after power switch.					
	17	E	-	GND.					
	18	DATA	I	Data input.					
	19	CLK	I	Clock data input.					
	20	NC	-	Not use.					
	21	N/CSW	I	Noise canseler microphone switch input.					
	22	PTT	O	PTT signal output.					
	23	LCS	-	Not use.					
	24	KEY2	O	Key output.					
	25	KEY1	O	Key output.					

TERMINAL FUNCTION / KNB-17A (Ni-Cd BATTERY)

CN No.	Pin No.	Name	I/O	Function					
CN No.	Pin No.	Name	I/O	Function					
					26	NC	-	Not use.	
					27	KCK	I	Key scan IC clock data input.	
					28	KRS	I	Key scan IC reset input.	
					29	INAFc	I	Internal speaker switch input.	
					30	EXAFC	I	External speaker switch input.	
					31	AMPSW	I	Audio AMP control switch input.	
					32	OPPTT	I	For optional board. (See page 22.)	
					33	TCONT	I	For optional board. (See page 22.)	
					CN2 for X57	1	AFE	-	Audio GND.
						2	AFE	-	Audio GND.
					CN3	1	Q8	O	Key scan IC Q8 signal output.
2	Q7	O	Key scan IC Q7 signal output.						
3	PTTE	-	PTT GND.						
4	PTT	I	Normally : 5V, transmit when connected GND.						
5	KI1	I	Key input.						
6	Q6	O	Key scan IC Q6 signal output.						
CN4	1	+	-	BTL + output for internal speaker.					
	2	-	-	BTL - output for internal speaker.					
CONTROL UNIT (X53-3780-XX) (B/6)									
CN101 for X57	1	E	-	GND.					
	2	TOGGLE	O	Normally : 5V, switched toggle when connected GND.					
	3	KI2	O	Key output.					
	4	Q6	I	Key scan IC Q6 signal input.					
	5	Q7	I	Key scan IC Q7 signal input.					
	6	CE	I	Chip select input for LCD driver.					
	7	CL	I	Clock data input for LCD driver.					
	8	DI	I	Data input for LCD driver.					
	9	LAMP	-	Backlight LED control. Normally : 0V, Lighting : 7.5V					
	10	TX LED	-	TX LED control. Normally : 0V, Lighting : 7.5V					
	11	BLED	-	Busy LED control. Normally : 0V, Lighting : 7.5V					
	12	5M	-	5V.					

KNB-17A External View



KNB-17A Circuit Diagram

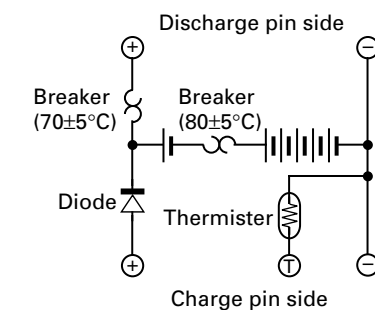

KNB-17A Specifications

Voltage	7.2V (1.2V x 6)
Charging current	1500mAh
Dimensions (mm)	58.0 W x 110.8 H x 20.0 D (Projections included)
Charger and charging time	
KSC-19 (Normal Charger)	Approx. 8 hours
KSC-20 (Rapid charger)	Approx. 1.3 hour
Weight	220g

KMC-25/26 (SPEAKER MICROPHONE)

KMC-25 External View



KMC-26 External View

Note : Stubby antenna are options



KMC-25/26 Specifications

Microphone
 Impedance2k
 Sensitivity -65dB±4.0dB at 1kHz

Speaker
 Impedance 16
 Input 0.5W
 Maximum input 1.5W

Dimensions 62 W x 81 H x 29 D (mm)
 Weight (With plug cord) Approx. 0.17kg

KMC-25/26 Circuit Diagram

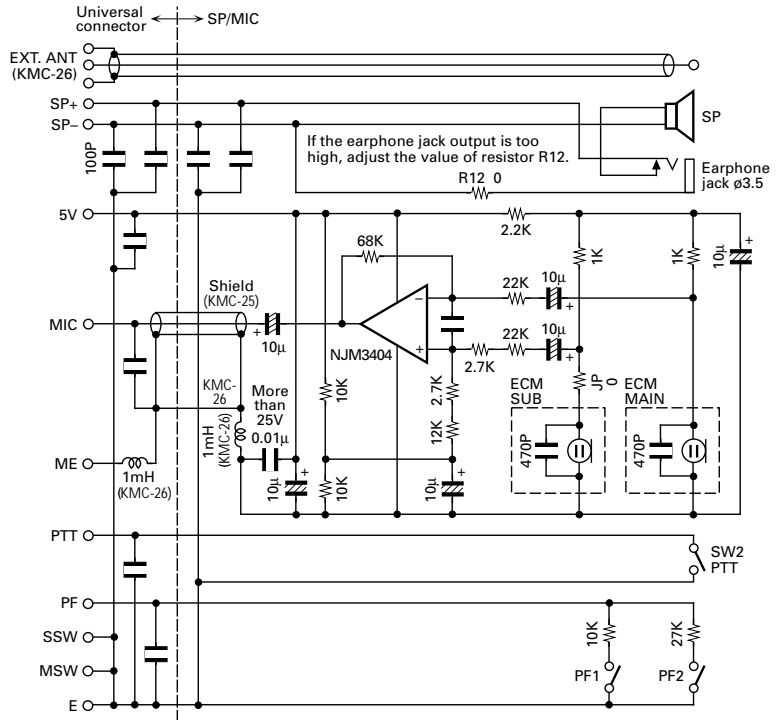

KMC-25/26 Parts List

* : New parts

Ref. No.	New parts	Parts No.	Description	Model
	*	A02-2092-08	Case (Front)	25
		A02-2253-08	Case (Front)	26
		A02-2093-08	Case (Rear)	25
	*	A02-2254-08	Case (Rear)	26
		B09-0382-08	Cap (Phone)	
		D10-0629-08	Lever (PTT)	
	*	E30-3287-08	Lead wire with plug assy	25
		E30-3322-08	Lead wire with plug assy	26
		J29-0644-08	Clip assy	
		J42-0495-08	Bushing	
		S70-0459-08	Tact switch	
		T07-0359-08	Speaker	
		T91-0584-08	MIC element	
		N08-0535-08	Dressed screw	

TK-290

KSC-19 (CHARGER) / KSC-20 (RAPID CHARGER) / KPG-36 (PROGRAMMING INTERFACE CABLE) / KRA-14 (HELICAL ANTENNA)

KSC-19 External View



KPG-36 External View



KSC-19 Charging

KNB-17A

Voltage	7.2V
Battery capacity	1500mAh
Charging time	Approx. 8 hours

KSC-20 External View



KRA-14 External View

M	: 148~162MHz
M2	: 162~174MHz
M3	: 130~159MHz



KSC-20 Specifications

Charging current	1100mA±150mA
Charging time	KNB-17A : 80 min.±24%
Source voltage	Approx 15V
Ambient temperature	0°C~40°C
Dimensions	105 W x 135 D x 52 H (mm)
Weight	0.18kg

SPECIFICATIONS

GENERAL

Frequency Range	136 to 174MHz
Number of Channels	160 channels
Channel Spacing	Wide : 25kHz, 30kHz, Narrow : 12.5kHz, 25kHz (PLL channel step 5kHz, 6.25kHz, 7.5kHz)
Battery Voltage	7.5V DC \pm 20%
Battery Life	10 hours at 5W (5-5-90 duty cycle)
Temperature Range	-30°C to +60°C (-22°F to +140°F)
Dimensions and Weight	6-3/32" (155mm) H x 2-5/16" (58mm) W x 1-1/2" (38mm) D, 1.25 lbs (565g)
With Keypad Model	6-3/32" (155mm) H x 2-5/16" (58mm) W x 1-9/16" (39.5mm) D

RECEIVER (Measurements made per EIA standard EIA-316-B)

Sensitivity	
EIA 12dB SINAD	0.25 μ V
20dB Quieting	0.35 μ V
Selectivity	Wide : -75dB, Narrow : -70dB
Intermodulation	Wide : -75dB, Narrow : -68dB
Spurious and Image Rejection	-75dB
Audio Power Output	500mW at less than 3% distortion
Frequency Stability	\pm 0.00025% from -30°C to +60°C
Channel Frequency Spread	38MHz

TRANSMITTER (Measurements made per EIA standard EIA-316-B)

RF Power Output	Hi : 5W, Low : 1W
Spurious and Harmonics	-70dB
Type of Emission	F3E, \pm 5kHz for 100% at 1000Hz
FM Noise	Wide : -45dB, Narrow : -40dB
Audio Distortion	Less than 3.0% at 1000Hz
Frequency Stability	\pm 0.00025% from -30°C to +60°C
Channel Frequency Spread	38MHz

KENWOOD CORPORATION

14-6, Dogenzaka 1-chome, Shibuya-ku, Tokyo 150-8501, Japan

KENWOOD SERVICE CORPORATION

P.O. BOX 22745, 2201 East Dominguez Street, Long Beach, CA 90801-5745, U.S.A.

KENWOOD ELECTRONICS LATIN AMERICA S.A.

P.O. BOX 55-2791 Piso 6 Plaza Chase Cl. 47 y Aquilino de la Guardia Panama, Republic of Panama

KENWOOD ELECTRONICS CANADA INC.

6070 Kestrel Road, Mississauga, Ontario, Canada L5T 1S8

KENWOOD ELECTRONICS DEUTSCHLAND GMBH

Rembrücker Str. 15, 63150 Heusenstamm, Germany

KENWOOD ELECTRONICS BELGIUM N.V.

Mechelsesteenweg 418 B-1930 Zaventem, Belgium

KENWOOD ELECTRONICS FRANCE S.A.

13, Boulevard Ney, 75018 Paris, France

KENWOOD ELECTRONICS U.K. LIMITED

KENWOOD House, Dwight Road, Watford, Herts., WD1 8EB United Kingdom

KENWOOD ELECTRONICS EUROPE B.V.

Amsterdamseweg 37, 1422 AC Uithoorn, The Netherlands

KENWOOD ELECTRONICS ITALIA S.p.A.

Via G. Sirtori, 7/9 20129 Milano, Italy

KENWOOD IBERICA S.A.

Bolivia, 239-08020 Barcelona, Spain

KENWOOD ELECTRONICS AUSTRALIA PTY. LTD.

(A.C.N. 001 499 074)

P.O. Box 504, 8 Figtree Drive, Australia Centre, Homebush, N.S.W. 2140, Australia

KENWOOD & LEE ELECTRONICS, LTD.

Unit 3712-3724, Level 37, Tower one Metroplaza, 223 Hing Fong Road, Kwai Fong, N.T., Hong Kong