

# Radius M130

## Field Radios

Operating Instructions

---

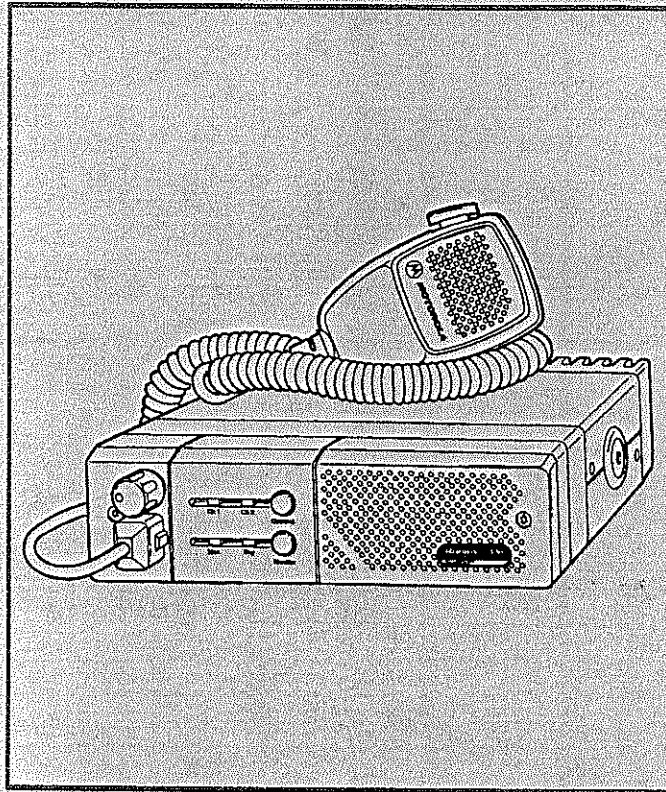

 **MOTOROLA**

<b>Computer Software Copyrights</b> .....	2
<b>Introduction</b> .....	3
Features List .....	3
Radio Self-Check .....	3
Radius Mobile Features .....	3
Service .....	4
<b>Dealer Programmable Features</b> .....	5
Field Programming Capabilities .....	5
Time-Out Timer .....	5
RapidCall Signalling .....	5
<b>Operating Instructions</b> .....	6
To Turn the Radio On .....	6
To Set the Radio Volume Level .....	6
To Receive .....	6
To Transmit .....	7
<b>RapidCall Operating Instructions</b> .....	8
To Receive a Call Alert .....	8
To Receive a Call Alert with Horn and Lights .....	8
To Receive a Voice Selective Call .....	9
<b>Installation Planning And Procedures</b> .....	10
Equipment Testing and Maintenance .....	10
Description of Power Protection Circuitry .....	10
Installation Planning--Mobile Radios .....	11
Installation Planning--Base/Control Stations .....	11
Recommended Tools .....	11
Antenna Mounting .....	11
<b>Radio Mounting</b> .....	12
Non-Locking Trunnion .....	12
Floor Mount .....	12
Quick Disconnect Slide Mount .....	12
Extra Stability Mounting Tray .....	12
Locking Trunnion .....	13
Remote Mount Capability .....	13
<b>Begin Installation</b> .....	14
DC Power Cable Installation .....	14
Non-Locking Trunnion Installation .....	15
<b>Accessories</b> .....	19
<b>Licensing And Safety Information</b> .....	21
Safety Standards .....	23
Safety Guidelines .....	24

## Computer Software Copyrights

The Motorola products described in this instruction manual include copyrighted Motorola computer programs stored in semiconductor memories or other mediums. Laws in the United States and other countries preserve for Motorola certain exclusive rights for copyrighted computer programs, including the exclusive right to copy or reproduce in any form the copyrighted computer program. Accordingly, any copyrighted Motorola computer programs contained in the Motorola products described in this instruction manual may not be copied or reproduced in any manner without the express written permission of Motorola. Furthermore, the purchase of Motorola products shall not be deemed to grant either directly or by implication, estoppel, or otherwise, any license under the copyrights, patents, or patent applications of Motorola, except for the normal non-exclusive, royalty fee license to use that arises by operation of law in the sale of a product.

## Introduction

Welcome to the Radius mobile family! Your choice of a Radius mobile means you have selected the highest of standards in design, quality, and performance. This manual is designed to acquaint you with all the features, care, and installation of the Radius mobile to better serve all your communication needs.

### *Radius Mobile Features*

The following features are standard in all models:

#### **Hardware Features**

- Radius High Performance Compact Microphone with Hardware
- Non-Locking Trunnion with Hardware
- 10 Ft. Power Cable
- Mini-UHF Antenna Connector
- Operator's Card and Owner's Manual

#### **Programming Features**

- Multiple Coded Squelch (Private Line and Digital Private Line) Capability
- Local/Distance per Channel Programmability
- Field Programming Capability at Dealer
- Time-Out Timer
- RapidCall Signalling Capability (MDC-1200 PTT-ID and Call Decode)

#### **Features Implicit to the Radio**

- Synthesized, Wide-Band Operation
- 12 V DC Negative Ground
- Mil-Spec 810 C, D and E Performance
- 3 Watt Internal Speaker
- Rotary Volume Control
- On-Hook Monitor Capability

### **Radio Self-Check**

Every time the radio is turned on, it performs a functional self-check and if necessary, will sound a 5 second warning tone instead of the chirp tone normally heard at power-up. This is an indication that the radio is no longer operating at the exact parameters set in the factory or field and should be serviced immediately.

## Service

Because this unit contains a radio transmitter, most local governments prohibit anyone from making any internal adjustments to the transmitter unless specifically licensed to do so by government regulations. If your radio fails to operate or any operational difficulties should arise, contact your local Motorola Radius dealer.

Proper repair and maintenance procedures will assure efficient operation and long life for this radio.

## Dealer Programmable Features

### *Field Programming Capabilities*

The Radius M130 mobile uses non-volatile memory to store customer unique information. If a frequency, squelch code or local/distance channel needs to be changed, it can be done at a service location with Radio Service Software (RSS). The Time-Out Timer can be disabled or changed to any duration from 1 to 255 seconds. The default setting is 60 seconds. It is not necessary to open the radio for reprogramming.

### *Time-Out Timer*

All models have a Time-Out-Timer (TOT) that will terminate your transmission if you hold the PTT button down for 60 seconds. To warn the user, an alert tone will sound from the speaker about 4 seconds before the transmission is cut. The Time-Out-Timer can be disabled or changed in duration. See your local dealer for more details.

### *RapidCall Signalling*

The M130 mobiles are offered with MDC-1200 RapidCall signalling features to support field radio operations. These radios can provide signalling features to improve your communicating efficiency. The programmable features include:

- **Push-to-Talk Identification (PTT-ID)**  
allows air time usage on RapidCall-equipped channels to be monitored by dispatchers on a per-unit basis. Each radio has its own ID, and specific transmissions can be linked back to radios and their users.
- **Call Alert Decode**  
allows field radios like the M130 to receive selective calls from control radios being used at a dispatching location. An incoming selective call is indicated by repeating tones that persist until you reset them by using radio controls. When your radio decodes the selective call, it sends an acknowledgement to the dispatcher radio.
- **Call Alert Decode with Horn and Lights Activation**  
alerts you to selective calls received by your radio when you are outside of your vehicle. When using this feature, an incoming selective call triggers the vehicle's horn and lights until you reset them by using radio controls. When your radio decodes the selective call, it sends an acknowledgement to the dispatcher radio.
- **Voice Selective Call Decode**  
is similar to voice paging in that a brief message can follow the initial tones of the call. The Voice Selective Call Decode resets after the voice message ends.

## Operating Instructions

(M130 Conventional FM Radio 2-Channel Model)

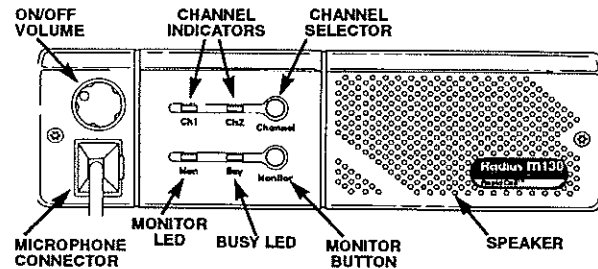

### To Turn the Radio On

Turn the ON/OFF VOLUME knob 1/2 turn clockwise. A start-up tone will be heard and a green LED CHANNEL INDICATOR light shows the last channel used by the radio.

### To Set the Radio Volume Level

Press the MONITOR BUTTON for two seconds (the amber MONITOR LED lights up and the amber BUSY LED flashes). You will hear "white noise", which means the radio is unscquelched. Adjust the ON/OFF VOLUME knob to a comfortable listening level. Press the MONITOR BUTTON again to return to normal receive mode.

### To Receive

Choose between channel 1 or 2 by pressing the CHANNEL SELECTOR button. Channels are shown by a green LED CHANNEL INDICATOR.

To receive only specific transmissions which have been pre-programmed with a PL/DPL code, remain on the selected channel and wait for a transmission. (The radio is now in the "coded squelch" or "PL/DPL" mode. This allows you to only hear transmissions which are meant for you).

To receive all transmissions on a selected channel, press the MONITOR BUTTON or take the microphone off hook.

The amber MONITOR LED is displayed. (The radio is now in the "monitor mode").

To return back to the "coded squelch" mode, press the MONITOR BUTTON again or place the microphone back on hook. This returns the radio to only receive transmissions meant for you.

### To Transmit

Choose between channel 1 or 2 by pressing the CHANNEL SELECTOR button. Channels are shown by a green LED CHANNEL INDICATOR.

Before transmitting, make sure the channel is clear. You can do this by either sight or sound. Visually, you can check the BUSY LED. The amber BUSY LED flashes whenever there is a transmission on the selected channel. You can also listen for a transmission by taking the microphone off hook.

Once the channel is clear, press and hold down the Push-to-Talk (PTT) button on the side of the microphone and speak slowly and clearly. The CHANNEL INDICATOR LED glows red and remains red until the PTT is released to indicate that you are "on-the-air".

#### NOTE

If your radio has the Time-Out-Timer function activated, transmission will terminate if the PTT button is pressed for over 60 seconds or the pre-programmed time period. When this occurs, an alert tone sounds for 4 seconds before the transmission is cut. To resume transmitting, release the PTT and press it again.

## Rapidcall Operating Instructions

(Mobile [Field Unit] Selective Signalling)

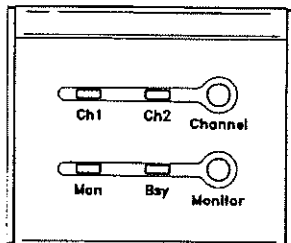

The Monitor LED is lit to indicate monitor mode in normal operations, and is also used to indicate received selective calls. When indicating received selective calls, the Monitor LED flashes.

### To Receive a Call Alert

When receiving a Call Alert, the amber Monitor LED flashes and a series of 4 alert tones sounds. Depending on the signalling format used, a voice message may follow. The Monitor LED flashes and the alert repeats every 10 seconds until you reset them by pressing the PTT or any other button on the radio. When your radio decodes the Call Alert, it sends an acknowledgement to the dispatcher radio. After acknowledgement, the radio returns to normal operation.

### To Receive a Call Alert with Horn and Lights

When your radio has been equipped with an external relay and programmed to use the Horn and Lights feature, incoming calls trigger the vehicle's horn and lights. The Horn and Lights feature can be programmed "ON" or "OFF" on a per-channel basis. Consult your radio dealer to determine which channels have been set up to provide this capability.

After a slight delay, the vehicle's horn and lights are triggered to alert you to an incoming Call Alert. If you are in or near your vehicle when your radio is receiving a Call Alert, you can prevent the horn and lights from being triggered by pressing the PTT or any button on the radio. When your radio decodes the Call Alert, it sends an acknowledgement to the dispatcher radio. After acknowledgement the radio returns to normal operation.

### To Receive a Voice Selective Call

When the radio receives a Voice Selective Call, a single 2-beep alert tone sounds and the amber Monitor LED flashes. The radio unmutes while it is receiving a voice message. When the voice message is finished, the radio returns to normal operation.

## Installation Planning And Procedures

### Testing and Maintenance

Your radio is completely adjusted, tested, and inspected before shipment. However, local governmental regulations may state that a station license be obtained for each radio installation (mobile or base) by the owner of the equipment. The station licensee is responsible for ensuring the transmitter power, frequency, and deviation are within the limits permitted under the station license.

No technician's license is required for installing and maintaining radio equipment. However, the frequency and deviation of the transmitter must be checked on installation and at least once yearly.

### Power Protection Circuitry

The Radius mobile you are installing has been tested for proper transmitter power output before leaving the factory. Each radio is set to the proper output power level while connected to an accurate 50 ohm load impedance. Once the power level has been set, the internal power control/protection circuitry will reduce the power output whenever it senses a load impedance significantly different from 50 ohms. This protection circuitry significantly enhances the radio's reliability with minimal performance degradation.

If you check transmitter output power levels during installation, be sure you are using a good 50 ohm load, with a minimum of adapters and using short test cables. Any load variation from 50 ohm may cause an apparent reduction in output power due to the normal operation of the control/protection circuitry. If power seems to be unusually low (greater than can be explained by the normal calibration differences you experience), check your test set-up. If power output goes up as you improve the quality of the load impedance (be sure to de-key when making any changes in load), the control/protection circuitry is performing normally.

Typical mismatches in the load impedance (greater than 1.2:1 VSWR) may result in a 10-20% variation in the actual measure power output. Within these limits, the radio operates normally and you should not attempt to service it.

### Installation Planning - Mobile Radios

Planning is the key to fast, easy radio installation. Before a hole is drilled or a wire is run, inspect the vehicle and determine how and where you intend to mount the antenna, radio, and accessories. Plan wire and cable runs to provide maximum protection from pinching, crushing, and overheating.

### Installation Planning - Base/Control Stations

The base/control station option provides the radio with a desk microphone and power supply for use at a fixed location. All operations are the same as the mobile, except for the desk microphone.

Choose a location for your base/control station as close as possible to where the antenna cable enters the building. Be sure 117V AC, 60 Hz power is available. Make sure sufficient air can flow around the radio to permit adequate cooling.

### Recommended Tools for Installation

The following tools are recommended for proper installation of your new radio:

- Portable Drill
- Hammer
- Center Punch
- 5/16" Hex Nut Driver
- 1/4" Hex Nut Driver
- Phillips #1 Screwdriver
- Phillips #2 Screwdriver
- 3/16" Blade Screwdriver
- 3/8" Diameter Drill Bit
- 5/16" Diameter Drill Bit
- 5/32" Diameter Drill Bit

### Antenna Mounting

The best mounting location for the antenna is in the center of a large, flat conductive surface. In almost all vehicles, these requirements are best satisfied by mounting the antenna at the center of the roof. Some vehicles have a large trunk lid that provides a good antenna location. If the trunk lid is used, connect grounding straps between the trunk lid and vehicle chassis to insure the trunk lid is a chassis ground. See the instruction manual supplied with the antenna for complete installation information.

## Radio Mounting

### **Non-Locking Trunnion**

The standard non-locking trunnion allows the radio to be mounted to a variety of mounting surfaces. Be sure the mounting surface is able to adequately support the weight of the radio. Allow sufficient space around the radio for free air flow for cooling. Be sure the unit is close enough to the vehicle operator to permit easy access to operating controls. Although the trunnion can be mounted to a plastic dashboard, it is recommended that the mounting screws be located so they penetrate the supporting metal frame of the dashboard.

### **Floor Mount**

A floor mount wedge (HLN9450) is available, which allows the radio to be tilted at either 45 or 60 degrees. (HLN9404 - Sleeve mounting bracket is also required).

### **Quick Disconnect Slide Mount**

The quick disconnect slide mount option is provided to allow easy removal and installation of the radio. This may be desired by the operator for security reasons or to allow the use of one radio in multiple vehicles. This mount securely mounts the radio and makes all electrical connections, including the antenna connection.

### **Extra Stability Mounting Tray**

The optional extra stability mounting tray is used in conjunction with the non-locking trunnion. If the radio is mounted on a rounded surface, you may need to supply and install shim washers (not provided) between the bracket and the mounting surface. Shims are necessary to tilt the radio because the heavy duty bracket blocks the standard trunnion adjustments. Follow instruction provided with the option.

### **Locking Trunnion**

The optional locking trunnion consists of a two-piece trunnion type mounting bracket equipped with a key lock and associated mounting screws and is designed to facilitate easy removal. The locking trunnion may be mounted on either metal or plastic surfaces, provided the mounting surface adequately supports the weight of the radio. Follow instructions provided with the option.

Before attempting to install the locking trunnion, examine the vehicle for suitable mounting locations. This bracket requires a flat mounting surface, 8" x 2" minimum with adequate clearance for inserting the radio. The chosen location should be convenient to the vehicle operator and provide access to the power and the antenna connectors. Be careful to choose a location that permits the locking trunnion to be removed from the mounting bracket. Vehicle operation should never be impaired by the location of the trunnion or radio.

---

**NOTE**

Overhead mounting is not recommended.

---

### **Remote Mount Capability**

The remote mount kit provides the necessary equipment to detach the front panel controls of the M130 from the transceiver. This allows for the installation of the transceiver box in the vehicle's trunk or under the seat.



## Begin Installation

### DC Power Cable Installation

This radio must be operated only in negative ground electrical systems. Reverse polarity does not damage the radio; however, radio protection circuits cause the cable fuse to open. Check the vehicle ground polarity before you begin installation to prevent wasted time and effort.

The 10 foot DC power cable shipped with the radio is long enough for installation in most vehicles. Begin the power cable installation in the following manner:

1. Determine a routing plan for the power cable with reference to where the radio is to be mounted.
2. Locate an existing hole with a grommet in the vehicle fire wall, or drill a 3/8" access hole at the location for passing the power cable into the engine compartment. Install a grommet with 1/4" I.D. in the access hole to avoid damage to the cable.

#### CAUTION

HIGH DEGREE OF CARE SHOULD BE EXERCISED NOT TO DAMAGE ANY EXISTING VEHICLE WIRES.

3. From inside the vehicle, feed the red and black leads (without lugs attached) through the access hole and into the engine compartment. (See Figure 1.)
4. Locate the nearest available vehicle chassis ground mounting point and shorten the black lead to remove excess cable length.
5. Install ring lugs (supplied) onto stripped end of power cable black lead, and onto stripped end of red lead on fuse holder as shown in Figure 2.
6. Locate the fuse holder as close to the battery as possible and away from any hot engine component. Mount the fuse holder using the provided mounting hole and dress wires as necessary. Connect the fuse holder red adapter lead plug to the mating receptacle on the red

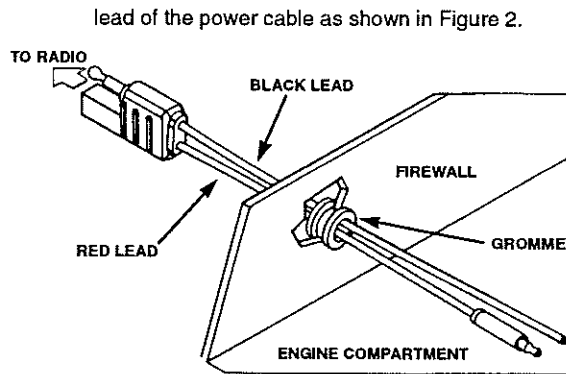

Figure 1. Power Cable Routing into Engine Compartment

7. Connect the power cable black lead directly to the VEHICLE CHASSIS GROUND. (See Figure 3).
8. Connect the power cable red lead from the fuse holder to the positive (+) battery terminal. Make sure the adapter cable is connected to the main power cable red lead. (See Figure 3).
9. Plug fuse into in-line fuse holder as shown in Figure 2.

#### NOTE

Failure to mount the red lead of the power cable kit directly to the battery may result in severe alternator whine interference and cause radio to revert to mode 1 each time the power is turned off.

### Non-locking Trunnion Installation

(See Figure 4)

1. Select the location to mount your radio either on the **Transmission Hump or Under the Dash** (see Figure 4).
2. Using the trunnion mounting bracket as a template,

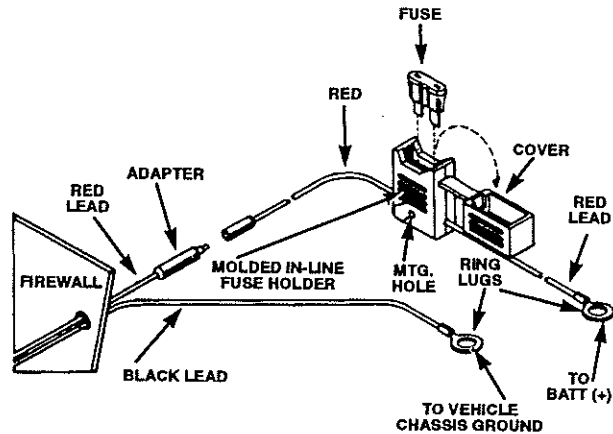
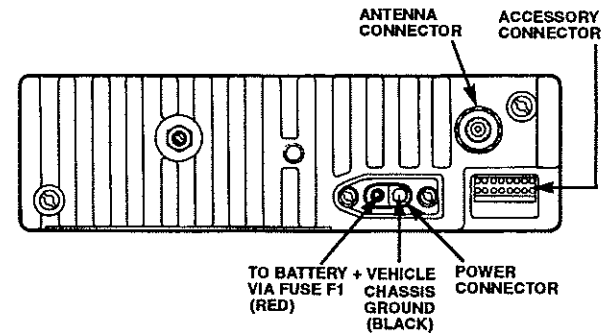

**Figure 2. Power Cable Assembly**

mark the positions of the holes on the mounting surface. Use the innermost four holes for a curved mounting surface such as the transmission hump, and the four outermost holes for a flat surface such as under the dash.

3. Center-punch the spots you have marked and drill a 5/32" hole at each.
4. Secure the trunnion mounting bracket and secure it with the two thumb screws provided.
5. To complete your radio installation plug the power cable into the radio POWER CONNECTOR (see Figure 3).
6. Mount the antenna using the instructions provided with the antenna kit. Run the coaxial cable to the radio mounting location. If necessary, cut off the access cable and install the cable connector.

7. Connect the antenna cable connector to the radio ANTENNA CONNECTOR on the rear of the radio. (See Figure 3).
8. Mount the microphone clip. Follow instructions provided with the microphone clip.
9. Plug the Microphone into the front panel connector. Your microphone has a telephone type connector at the end of its cord. Connect and disconnect your Radio Microphone in the same manner you connect and disconnect your telephone handset.



**Figure 3. Connections to Radio Rear Panel**

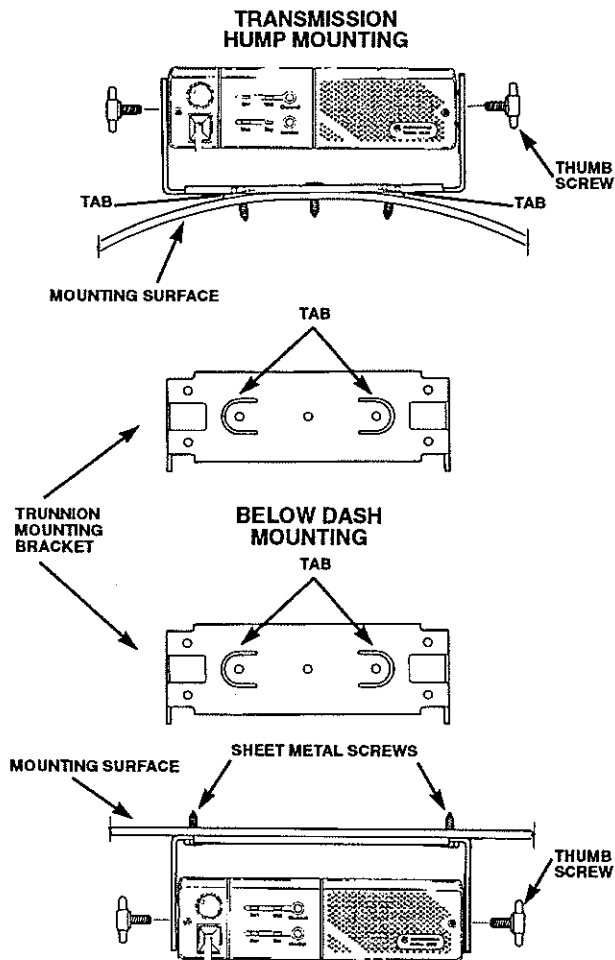

Figure 4. Trunnion Mount for Radio

## Accessories

Radius offers several accessories to increase communications efficiency. Many of the accessories available are listed below, but for a complete list, consult your Radius dealer.

### Antennas:

HAD4006_R	VHF 136-144 MHz, 1/4 wave roof mount
HAD4007_R	VHF 146-150.8 MHz, 1/4 wave roof mount
HAD4008_R	VHF 150.8-162 MHz, 1/4 wave roof mount
HAD4009_R	VHF 162-174 MHz, 1/4 wave roof mount
HAD4014_R	VHF 146-172 MHz, 3dB gain roof mount
HAE4003_R	UHF 450-470 MHz, 1/4 wave roof mount
HAE4004_R	UHF 470-512 MHz, 1/4 wave roof mount
HAE4002_R	UHF 403-430 MHz, 1/4 wave roof mount
HAE4010_R	UHF 406-420 MHz, 3.5dB gain roof mount
HAE4011_R	UHF 450-470 MHz, 3.5 dB gain roof mount
HAE4012_R	UHF 470-512 MHz, 3.5dB gain roof mount
HAE4013_R	UHF 494-512MHz, 3.5dB gain roof mount
HAE4019_R	UHF 450-470 MHz, 3.5 dB gain roof mount

### Microphones:

HMN3596_R	Compact Palm Microphone with 7 foot cord
HMN1035_R	Heavy Duty Palm Microphone with 10.5 ft. cord
HMN1037_R	Touch-code Microphone with hang-up clip
TDN8305_R	Touch-code Mic. with backlit keypad & hang-up clip
TMN6169_R	Touch-code Mic. with memory dial, backlit keypad & hang-up clip
HMN3141_R	Handset with hang-up cup
HLN9559_R	7 foot coil cord for Compact and Heavy Duty Microphones
HLN9560_R	10.5 foot extended coil cord for Compact and Heavy Duty Microphones
HLN9073_R	Microphone hang-up clip (all microphones)
HMN3001	M10 compact microphone with hang-up clip
HMN3002	M10 compact LED microphone with hang-up clip

### Installation Accessories:

HLN9284_R	Key lock mount
HLN5189_R	Non-locking bracket
HLN5226_R	Extra stability mount (use with HLN5189)
HLN9450_R	45 - 60 degree floor mount wedge (requires HLN9404)
HLN9404_R	Sleeve mounting bracket
HKN4137_R	VHF/UHF/800 MHz low power cable

HLN5282_R	Mini-U connector (all bands)
HKN9557_R	PL259/Mini-U antenna adapter - 8 inch cable
HLN8027_R	Mini - UHF to BNC antenna adapter
HLN8097_R	Removable slide mount tray package
HLN8098_R	Radio slide mount tray
HLN8099_R	Vehicle slide mount tray
HLN8143_R	Remote mount kit (17 FT. length)
HLN8144_R	Remote mount kit (8 FT. length)
HLN8413_R	Slide mount tray bracket
HLN9328_R	External Alarm Relay and Cable

**Control Station Accessories:**

HMN3000_R	Desk Microphone
HPN4001_R	Power supply and cable (all models)
HPN4002_R	Power supply and cable (1-10, 10-25 watt models)
HKN4139_R	Low power control station power cable (VHF/UHF)
HKN9455_R	High power control station power cable (VHF/UHF)
HLN5292_R	Base tray for control station

**Accessories / Kits interfacing with the 16 Pin Connector:**

HKN9327_R	Ignition switch cable
HSN8145_R	7.5 Watt external speaker - for receiver audio
HKN9969_R	Accessory for repeater interface communications kit-additional 3 foot, 16 conductor cable for connection to other accessories
HLN3333_R	Repeater interface communications kit- includes interface box, mounting bracket, and two 6 conductor cables
HLN9457_R	Hardware kit-includes 16 conn. pins, (9) 8" wires with pins & extra housing
TDN8300	DC Remote adapter and service manual - 2 channel operation order desktop controller separately)
TDN8301	Tone remote adapter and service manual - 2 channel operation (order desktop controller separately)

**Manuals:**

6880902Z98	Service manual
6880902Z96	Operator's card
6880902Z43	DTMF Manual
TDN8198	i50X Radio-Telephone interconnect service manual
TDN8448	DC Remote adapter manual
TDN8449	Tone remote adapter manual

**Licensing And Safety Information**

Your Radius radio operates on FM radio communication frequencies and is subject to the Rules and Regulations of the Local Communications Governing Agencies. These agencies may require that all operators using Private Land Mobile or General Mobile Radio frequencies obtain a radio license before operating their equipment. The operator receives a license for use of the radio equipment under a specific eligibility and on a particular frequency or set of frequencies. To determine eligibility for use of Private Land Mobile Service frequencies contact your local communications governing agency. They will be able to supply information required to properly obtain and complete the license application form.

**Agency addresses for several countries are listed below:**

**In the United States contact:**

Federal Communications Commission  
Consumer Assistance  
Branch License Division  
Gettysburg, PA 17326  
Tel (717) 337-1212

**In Canada contact:**

Head Equipment Approval Unit  
Department of Communications  
1241 Clyde Avenue  
Ottawa, Ontario K2C-1Y3  
Canada  
Tel (613) 998-5968

**In the United Kingdom contact:**

Radio Communications Agency  
P.O. Box 20  
London  
SE1 8TZ  
Tel 71 215 2152

**In Mexico contact:**

Secretaria De Comunicaciones Y Transportes  
Direccion General De Politicas  
Y Normas De Comunicaciones  
Av. Eugenia No. 197-5o. Piso  
Mexico, D.F. 06700

**In Singapore contact:**

Telecommunications Authority of Singapore  
3rd Storey Comcenter  
31 Exeter Road  
Singapore, 0923  
Singapore

**In Japan contact:**

Communications Research Laboratory  
Ministry of Posts & Telecommunications  
MKK Building  
7-2, 5-chome  
Yashio, Shinagawaku  
Tokyo, 140 Japan

**In Hong Kong contact:**

Hong Kong Telecommunications Authority  
Telecommunications Branch  
Post Office, Hong Kong  
6/F Sincere Building  
173 Des Voeux Road Central  
Hong Kong

**Safety Standards**

The FCC, with its action in General Docket 79-144, March 13, 1986, has adopted a safety standard for human exposure to radio frequency electromagnetic energy emitted by FCC regulated equipment. Motorola subscribes to the same safety standard for the use of its products. Proper use of this radio will result in exposure below government limits.

**The following precautions are recommended:**

- **DO NOT** operate the transmitter of a mobile radio when someone outside the vehicle is within two feet (0.6 meter) of the antenna.
- **DO NOT** operate the transmitter of a fixed radio (base station, microwave, the rural telephone RF equipment) or marine radio when someone is within two feet (0.6 meter) of the antenna.
- **DO NOT** operate the transmitter of any radio unless all RF connectors are secure and any open connectors are properly terminated.
- **DO NOT** operate the equipment near electrical blasting caps or in an explosive atmosphere.
- All equipment must be properly grounded according to Motorola installation instructions for safe operation.
- All equipment should be serviced only by a qualified technician.

## Safety Guidelines

### INSTALLATION SAFETY WARNING

Consider the occupants' safety when you choose a location for the radio. Do not mount the radio overhead or on a side wall unless you take special precautions.

If someone were to remove the radio and fail to replace it properly, road shock could bump the radio loose, and the falling radio could, in some circumstances, cause serious injury to the driver or a passenger. In a crash, even when properly installed, the radio could break loose and become a dangerous projectile.

If you must mount the radio overhead or on a side wall, give it the added protection of a retaining strap.

### OPERATIONAL SAFETY WARNINGS

#### WARNING

For vehicles equipped with electronic anti-skid systems, see "ANTI-SKID BRAKING PRECAUTIONS" Publication, Motorola Number 68P81109E34.

#### WARNING

For vehicles equipped with electronic ignition systems, check the service manual for warnings about the use of two-way radio equipment in the vehicle.

#### WARNING

It is mandatory that radio installations in vehicles fueled by liquefied petroleum gas conform to the following standards:

National Fire Protection Association standard NFPA 58 applies to radio installations in vehicles fueled by liquefied petroleum (LP) gas with LP gas container in the trunk or other sealed-off space within the interior of the vehicles. This standard requires that:

1. Any space containing radio equipment shall be isolated by a seal from the space in which the LP-gas container and its fittings are located.
2. Remote (outside) fitting connections shall be used.
3. The container space shall be vented to the outside.

#### CAUTION

### INSTALLATION OF ANTENNAS WITH MOBILE RADIO EQUIPMENT WITH TRANSMITTER POWER IN EXCESS OF 7 WATTS

#### NOTE

For low power mobile radios (7 watts or less), there are no antenna type or installation restrictions.

**Non-Metallic Body Vehicles** - In non-metallic body vehicles with transmitters at any frequency having a power output in excess of 7 watts, **do not** install any type of antenna closer than 2 feet in distance from any occupant of the vehicle. Failure to follow this procedure may result in the exposure, of the vehicle occupants, to radio frequency energy levels higher than recommended by the American National Standards Institute (ANSI).

**Metal Body Vehicles** - In metal body vehicles with transmitters at any frequency having a power output in excess of 7 watts, it is mandatory that when using a glass mount antenna the installation instructions covering the location of the antenna at the top of the front or rear window and the

cable routing be followed exactly as described. Failure to follow this procedure may result in the exposure of the vehicle occupants to radio frequency energy exposure levels higher than recommended by the American National Standards Institute (ANSI).

For other antenna types follow the existing installation instructions. The best location for the antenna is at the center of vehicle roof. A good alternate location is at the center of the trunk lid.

**IMPORTANT**

If installations different from these recommendations have already taken place, immediately notify your local Service Representative so that appropriate corrective action can be taken.

**CAUTION**

**UNSAFE USE OF CONVERTED MOBILE EQUIPMENT FOR PORTABLE APPLICATIONS**

Motorola two-way radio products which have been designed for mobile operation should not be used as battery operated portable units. In such use there is the danger that the user or other persons will be exposed to excessive radio frequency energy levels. This warning applies to all two-way radio equipment radiating in excess of seven (7) watts RF power. Motorola strongly recommends that any product which converts high power equipment for portable operation not to be used.

**NOTES**

Multiple horizontal lines for taking notes.

 Motorola, Radius, Private-Line, Digital Private-Line, RapidCall,  
and Touch Code are trademarks of Motorola, Inc.



6880903Z64-O

Motorola  
Radius Products Division  
Hwy 34 West  
Mt. Pleasant, IA 52641