

MIDLAND LMR

LAND MOBILE RADIO

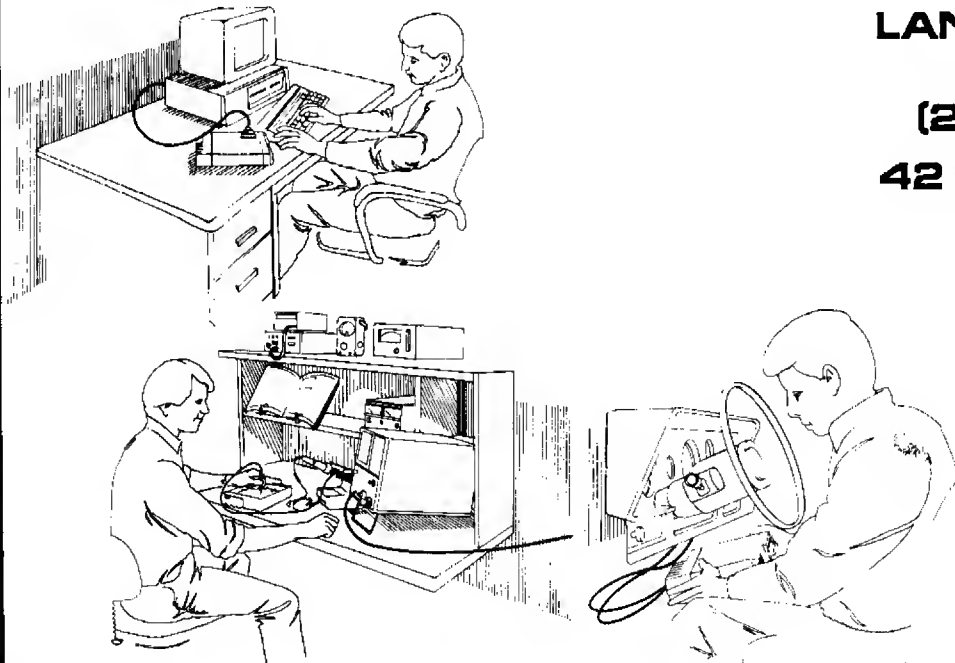

70-0371A/B/C AND 70-0375A/B/C
SYN-TECH XTR
FM TWO-WAY
LAND MOBILE RADIO
VHF LOW BAND
(29.7 - 36 MHz/36 -
42 MHz/42 - 50 MHz)
110 WATT



MANUAL NO. 70-371375
09-0371/0375-SM-7/91-2M

This user's manual is designed to facilitate the set-up and service of the MIDLAND 70-0371/0375 SYN-TECH XTR mobile transceivers. As necessary, user's manual supplements will be published and distributed on the following forms:

- Manual Addition (MA) For supplemental information useful in product service or improvement. Printed on BLUE paper.
- Change Notice (CN) For details about changes made during production by model and serial number. Printed on YELLOW paper.
- Manual Correction (MC) For correcting literature errors not related to production changes. Printed on GREEN paper.
- Technical Bulletin (TB) For solutions to field problems and tips for performance improvement. Printed on PINK paper.

Comments or suggestions concerning areas of manual improvement are welcome.

TABLE OF CONTENTS

Manual Supplement Information	ii
Table of Contents	iii

SECTION 1

GENERAL INFORMATION

Description	1 - 3
Specifications	1 - 3
Accessories	1 - 5

SECTION 2

PREPARATION

Preinstallation Check	2 - 3
Start-Up	2 - 3
Complete Realignment	2 - 4

SECTION 3

INSTALLATION

Installation	3 - 3
--------------------	-------

SECTION 4

SERVICING

Removing the TR-053 Board	4 - 3
Removing the PA-0502 Board	4 - 5
Troubleshooting Charts	4 - 7
Component Replacement	4 - 19
Eliminating Radio Interference	4 - 23
DC Voltages	4 - 27

SECTION 5

CIRCUIT DESCRIPTIONS

RF Section	5 - 3
110-Watt PA Section	5 - 5
Logic Section	5 - 5
IC901 Pinouts	5 - 7

SECTION 6

DIAGRAMS

Block Diagram 6 - 3
Under-Dash Wiring Diagram 6 - 4
Trunk-Mount Wiring Diagram 6 - 5
Control Head Layouts 6 - 6
Under-Dash Control Head Schematic 6 - 7
Trunk-Mount Control Head Schematic 6 - 8
TR-053 Layout—Bottom View 6 - 9
TR-053 Layout—Top View 6 - 10
TR-053 Schematic Diagram 6 - 11
TR-053 Transistor Schematic Pinouts 6 - 12
TR-053 Diode Schematic Pinouts 6 - 12
Z-593 Interface Schematic 6 - 13
Z-593 Layout 6 - 13
PA-0502 Layout 6 - 14
PA-0502 Schematic Diagram 6 - 15
Z-594 Layout 6 - 16
70-2157 (CTCSS) Layout 6 - 16
70-2157 (CTCSS) Schematic 6 - 17
Under-Dash Exploded View 6 - 18
Trunk-Mount Exploded View 6 - 19

SECTION 7

PARTS

Parts List 7 - 3
Replacement Parts Ordering 7 - 13

SECTION 1 - General Information

1

SECTION 2 - Preparation

2

SECTION 3 - Installation

3

SECTION 4 - Servicing

4

SECTION 5 - Circuit Descriptions

5

SECTION 6 - Diagrams

6

SECTION 7 - Parts

7

SECTION 1

GENERAL INFORMATION

GENERAL INFORMATION

70-0371/0375

NOTES

DESCRIPTION

The 70-0371/0375 MIDLAND SYN-TECH XTR transceivers are programmable frequency-synthesized two-way FM mobile radios that operate in the low-band VHF frequency range. They are programmable for up to 22 channels, or up to 99 channels with plug-in option.

The 70-0371/0375 are designed to operate within one of three frequency ranges: 29.7—36 MHz (A-Band), 36—42 MHz (B-Band), or 42—50 MHz (C-Band). Transmit RF power is programmable for 55—110 watts.

There are two types of control head configurations for the SYN-TECH XTR. Either the entire radio can be mounted under the vehicle dashboard (model number 70-0371), or the bulk of the radio can be placed under a seat or in the trunk, with only the control panel mounted in the operator's reach (model number 70-0375). If the 70-0371 is purchased, the XTR is shipped with the Control Panel attached. If the 70-0375 is purchased, the XTR is shipped with a cable-interface board and handle assembly mounted in place of the Control Head on the transceiver, and a separate Control Head. The two units must be connected together with a multi-conductor cable when installed.

1

SPECIFICATIONS

Refer to EIA-152-C, EIA/TIA-204-D, and DOC RSS-119, Issue 3 for standard of performance and method of measurement.

GENERAL**OPERATING FREQUENCY RANGE:**

A-Band: 29.7—36 MHz

B-Band: 36—42 MHz

C-Band: 42—50 MHz

COMMUNICATION SYSTEMS: Press-to-talk (1 or 2 frequency simplex)**CHANNEL SPACING:** 20 kHz**CHANNEL STEPPING:** 2.5 kHz**CHANNELS:** 22 or 99 (optional)**REFERENCE OSCILLATOR:** Microcomputer controlled**DUTY CYCLE:** 1 minute TX, 4 minute RX**POWER SUPPLY:** 13.4 V DC negative to ground**OPERATING VOLTAGE RANGE:** 12.2 to 15.0 V**ABSOLUTE VOLTAGE RANGE:** 10.9 to 16.3 V

GENERAL INFORMATION

70-0371/0375

CURRENT DRAIN:

Standby: 0.3 A (varies with options)
Receive (at full rated audio): 1.0 A (approx.)
Transmit (full power): 25.0 A (approx.)

RF IMPEDANCE: 50 Ω unbalanced

OPERATION TEMPERATURE: -30° C to $+60^{\circ}$ C

RELATIVE HUMIDITY: 90% at 50° C $\pm 2^{\circ}$ C

SHOCK: MIL 810D 516.3 Procedure I

VIBRATION: MIL 810C 514.2 Procedure VIII-V Category f
MIL 810D Method 514.3I-3.2.10

DIMENSIONS (H x W x D):

TX/RX Unit: 2.25 x 7.75 x 13.77 in (57 x 196 x 350 mm)
Remote Control Head: 2.25 x 4.75 x 3.31 in (57 x 120 x 84 mm)
Speaker: 4.81 x 4.81 x 2.87 in (121 x 121 x 72 mm)

WEIGHT:

Dash-mount: 9.7 lb (4.39 kg)
Trunk-mount: 14.1 lb (6.39 kg)

TRANSMITTER

RF POWER OUTPUT (programmable): 55—110 W, dual RF power levels

FREQUENCY STABILITY (-30° C to $+60^{\circ}$ C): $\pm 0.0005\%$ standard, $\pm 0.0002\%$, optional

MODULATION (direct FM): 16K0F3E, 5 kHz maximum

FREQUENCY SEPARATION:

A-Band: 6.3 MHz
B-Band: 6 MHz
C-Band: 8 MHz

SPURIOUS & HARMONICS: -66 dB

FM HUM & NOISE: -50 dB

AUDIO RESPONSE: per EIA and DOC specifications

AUDIO DISTORTION (at 60% deviation): 3% or less at 1000 Hz

OUTPUT IMPEDANCE: 50 Ω

RECEIVER

FREQUENCY STABILITY (-30° C to +60° C): ±0.0005% standard, ±0.0002% optional

SENSITIVITY (12 dB SINAD): 0.30 μV

SELECTIVITY (±30 kHz): -80 dB

FREQUENCY SEPARATION:

A-Band: 6.3 MHz

B-Band: 6 MHz

C-Band: 8 MHz

ACCEPTABLE RADIO FREQ. DISPLACEMENT: ±2.0 kHz minimum

SPURIOUS REJECTION: -80 dB

INTERMODULATION: -80 dB

SQUELCH SENSITIVITY: 0.18 μV maximum

AUDIO OUTPUT:

Int: 3 W at 3% distortion or less

Ext: 10 W at 3% distortion or less (into 3.2 Ω)

(Trunk-mount models measured at control head accessory connector with 4 meter maximum control cable. For longer control cables, measurement must be made at accessory connector on rear of radio.)

INPUT IMPEDANCE: 50 Ω

— All specifications subject to change without notice —

ACCESSORIES

OPTION KITS:

- 70-2180 99 Channel Option
- 70-2119 2 ppm Frequency Stability Kit
- 70-2120 2.5 ppm Frequency Stability Kit
- 70-2163 2nd IF Reverse Injection Kit
- 70-2963-1 MIL 810 C/D dust/rain/salt fog Kit
(T/M Control Head only)
- 70-2963-3 MIL 810 C/D dust/rain/salt fog Kit
(T/M Main Unit only)



GENERAL INFORMATION

70-0371/0375

SIGNALLING OPTIONS

70-2157	CTCSS/DCS Filter
70-2410	Digital Voice Storage/In Band Repeater (Requires 2413A Interface Board)
70-2412A	Rolling Code Variable Split Band Scrambler (Requires 2413A Interface Board)
70-2413A	Interface Board
70-2415	2 Tone Sequential Decoder
70-2416	Private Squelch
70-2418	Burst Tone Encoder
70-2419	Reverse Burst Generator
70-2420A	DTMF Decoder

SPEAKERS AND MICROPHONES

70-2302	Weatherproof Microphone
70-2306	Microphone
70-2103A	DTMF Microphone with Up-Down Channel Switch w/6 Pin Jack Kit (70-K33-1)
70-2104A	DTMF Microphone with Up-Down Channel Switch and ANI w/ 6 Pin Jack Kit (70-K33-1)
70-2305B	Dynamic Base Station Microphone (w/70-K33-1)
70-2311	Telephone Handset (70-K37 required)
70-2195	CTCSS Microphone Hang-Up switch
70-2355	15 Watt Remote Speaker
70-2356	15 Watt Weatherproof Speaker
70-2365	15 Watt Horn Speaker
70-2324	Talk Around Microphone (70-K35-2A required)
70-2325	Heavy Duty Amplified Condensor DTMF Microphone (w/ illuminated keypad)

MISCELLANEOUS

70-2269	Conversion Kit — Trunk Mount to Dash Mount
70-2270	Conversion Kit — Dash Mount to Trunk Mount
70-7070	Weatherproof Housing
70-2218	Ignition Relay Kit
70-2925	Memory Back up Kit (Short Term)
70-2926	Memory Back up Kit (Long Term)
70-2197	Electronic Noise Filter, 25 A

SECTION 2

PREPARATION

PREPARATION

70-0371/0375

NOTES

PREINSTALLATION CHECK

NOTE: Alignment will require a programmer: either the 70-1080A programmer (with Version 15.1 firmware or later) or the 70-1489 PC Programming software.

• **Setup**

1. Remove the eight securing screws on the cover and the cover itself.
2. If not already in place, connect the proper Control Head to the TX/RX Unit.
3. Connect a resistive, 50-Ω RF load (with a wattmeter) to Antenna Connector J502.
4. Connect 13.4 V DC power to J504.
5. Turn the radio on, turn MON on, turn selective signaling options off.

• **Carrier Frequency**

6. Initiate transmit on any channel. Measure transmitted RF carrier frequency without modulation and, if needed, set carrier frequency within ±100 Hz of channel frequency using the programmer. Refer to the CRYSTAL ALIGNMENT on page 2 - 6 for details.

7. RF output power is adjustable through the programmer. Initiate transmit on any channel. Measure power of RF output at 50-Ω Antenna Connector J502 and, if needed, adjust RF output power to obtain 110 W using the programmer. J402 is the interface connector between the transceiver and the programmer.

• **Maximum Deviation**

8. Select a channel with transmit frequency of 30 MHz for A-Band, 36 MHz for B-Band, or 42 MHz for C-Band. If CTCSS or DCS is used, be sure the channel is programmed to send the same frequency.
9. Disconnect the hand microphone from its front panel receptacle J301. Apply 3 V_{rms} of 1000 Hz signal to pin 1 of Mic Jack J301, then initiate transmit by grounding pin 4. Measure total carrier deviation. If it is not below ±5 kHz (including optional CTCSS/DCS signal), see MODULATOR ALIGNMENT on page 2 - 5.

START-UP

10. Program the radio customer frequencies and select features using the MIDLAND 70-1080A SYN-TECH XTR/II Programmer and its instruction manual.
11. The 70-0371/0375 Units are capable of operating across a wide band of channel frequencies; frequency selective circuits do not require realignment after the units are programmed with customer channel frequencies. After programming, only a general check of proper operation is needed. If any minor adjustments are necessary, refer to COMPLETE REALIGNMENT. These adjustments are of a general nature and do not require atypical equipment.

12. Install the radio into the vehicle (refer to Section 3 for instructions).

CAUTION: Do not ground any speaker wires because they are all electrically hot (each wire is connected to a differential audio amplifier output).

NOTE: You must use the 70-1080A Programmer, the 70-1083 Jumper Plug, or 70-1489 PC Programming software to set Carrier Frequency, Maximum Deviation and RF Output Power.

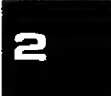

PREPARATION

70-0371/0375

COMPLETE REALIGNMENT

Complete realignment is only needed when a component that affects alignment has been replaced. RADIO REPROGRAMMING WITH TEST FREQUENCIES IS REQUIRED.

Table 2 - 1 — Test Equipment Required

TEST INSTRUMENT	INSTRUMENT CAPABILITIES	USE
Regulated DC Power Supply	13.4 V DC, 30 A, adjustable voltage	Radio power source
RF Wattmeter	150 W, 29.7—50 MHz, 50 Ω circuit	Transmitter power measurements
RF Load Resistor	50 Ω @ 200 W	Antenna dummy load
Frequency Modulation Meter	29.7—50 MHz, peak- responding, ± 5 kHz range	Modulation level measurements
Frequency Meter or Frequency counter	29.7—50 MHz, 1.0 ppm accuracy	Carrier frequency measurement
Audio Generator	1000 kHz sine wave, 0—4 V_{rms} output	Modulation level measurements
RF Signal Generator	29.7—50 MHz range 0.1—1 μV output, ± 3 kHz FM mod. with 1 kHz tone	All receiver measurements
Distortion Analyzer	1 kHz notch, 1% measuring range	Receiver performance test and IF alignment
Load Resistor (audio)	3.2 Ω , 20 W	Speaker load for all receiver measurements
AC Voltmeter	10 mV to 10 V_{rms}	Audio level adjustments
Oscilloscope	DC to 500 kHz bandwidth	DCS analysis
Digital Multimeter	0.1 to 20 V DC	Test point measurements and power supply setup
Programmer	MIDLAND 70-1080A (Version 15.1 firmware) or 70-1489 PC Programming software	Manual radio control

SET UP

1. Remove the eight securing screws from the bottom cover and the cover itself.
2. If not already in place, connect the proper Control Head to the TX/RX Unit.
3. Connect a resistive 50-Ω RF load and a wattmeter to Antenna Connector J502.
4. Connect 13.4 V DC power to transceiver J504.
5. Connect a 3.2-Ω, 20-W resistor to pins 4 and 6 of the Accessory Plug. The jumper between pins 5 and 6 must be temporarily disconnected to make this connection. The resistor serves as a constant load to replace the speaker's inconsistencies.

CAUTION: Both speaker terminals are LIVE! Never ground either one. Connect grounded receive-audio measuring equipment to only one side of the speaker, and chassis ground. Normally, voltage measurements will be half of true values.

1. Turn the radio on, set the Volume control to a mid-position, and set the Squelch control fully counter-clockwise.
2. Connect the programmer to Programming Port J402. Upload the radio programming Data-Packet into the programmer and initiate its Remote Control Mode. Refer to the appropriate manual for instructions.

SYNTHESIZER ALIGNMENT

• **VCO Resonance**

1. Select the Remote-Control Mode of the Programmer and change the RX and TX test frequencies to 30.00 MHz for A-Band, 36.00 MHz for B-Band, or 42.00 MHz for C-Band.
2. Adjust Channel RX Tank L713 to obtain 1.5 V DC on CM701 pin 1.

3. Activate the transmit mode (using the programmer). Adjust Channel TX Tank L733 to obtain 1.5 V DC on CM701-pin 1.

• **Crystal Type Selection**

4. Select the Test Mode of the Programmer, and choose Crystal Type as follows: X101 is marked "1", select Type 1; if X101 is marked "2", select Type 2; if X101 is marked "3", select Type 3. Refer to Crystal Alignment (page 2 - 6) for complete alignment instructions.

• **Reference Oscillator**

5. Initiate transmit on any channel. Measure transmitted RF carrier frequency without modulation and, if necessary, adjust L101 to bring the carrier frequency to within ±100 Hz of channel frequency.

110-WATT PA SECTION ALIGNMENT

1. Change the TX test to 30 MHz for A-Band, 36 MHz for B-Band, or 42 MHz for C-Band. Activate transmit mode.
2. Set RF output power to 110 W at J502 using the programmer.

MODULATOR ALIGNMENT

Always perform Modulator Alignment in its entirety—the following adjustments are interactive.

• **Modulation Limiting**

1. Disconnect the hand microphone from its front panel receptacle J301.
2. Apply 3 V_{rms} of 1000 Hz signal to pin 1 of Mic Jack J301, then initiate transmit (if not using the programmer, ground J301 pin 4).
3. Measure total carrier deviation and, if needed, adjust modulation limiting to obtain ±5 kHz using the programmer.

• **Microphone Gain**

4. No alignment for microphone gain is required.



PREPARATION

70-0371/0375

CRYSTAL ALIGNMENT

This alignment is required when a part in the reference oscillator circuit is replaced. This alignment is not needed during normal maintenance and radio alignment or programming.

When parts in the reference oscillator circuit are replaced, including the crystal, it is necessary to select the temperature compensation data of the microcomputer in accordance to the crystal markings. There are three types of crystals as (see Table 2 - 3). There are two ways to determine what type of crystal you have, either by the color of the dot on the top of the crystal or the type number on the side. See the example shown in Figure 2 - 2. See Figure 2 - 1 for crystal location.

The procedure varies depending on what programmer is used. Proceed to the correct instructions for the programmer you are using.

• 70-1080A Programmer

Refer to the 70-1080A Programmer's Manual for more information.

1. Connect the radio to power and test equipment as described under the alignment procedure section of the service manual.
2. Connect the 70-1080A programmer to the radio.
3. Upload the contents of the radio into the 70-1080A programmer.
4. Enter the test mode by pressing CH, 0, then ENT.
5. Enter the correct RX (receive) and TX (transmit) test frequency for the radio. **NOTE:** The CTCSS and DCS does not need to be used for this test.
6. Press GRP, 4, then ENT. 'XTAL CHANGE OK ?' will be displayed.
7. Press ENT. 'XTAL TYPE SELECT' will be displayed. Determine the type of crystal the radio has installed as shown in Figures 1 and 2 and enter the correct type as shown in Table 2 - 3.

8. Press ENT. 'DA CONTROL' will be displayed.
9. Press 3, then ENT. 'FO CONTROL' with a number (0 — 63) on the bottom line, representing the adjustment point of the reference oscillator frequency trim, will be displayed.
10. Measure the temperature of the body of R107 using a contact type thermometer. You must hold the thermometer on R107 for at least one minute before taking the temperature reading. R107 is located under the VCO shield (see Figure 2 - 1).
11. Using a digital voltmeter, measure the DC voltage on pin 60 of the microcomputer.
12. Find the measured temperature of R107 in Table 2 - 4 and find the corresponding voltage for the type of crystal installed. Compare this voltage to that measured in step 11.
13. If the voltage does not match within 0.02 V DC, adjust it by using the UP or DOWN keys on the 70-1080A programmer until the DC voltage on pin 60 of the microcomputer is correct. Typical setting should be between 30 — 40.
14. When complete press FNC, then OPT. 'DA DATA PROG END' will be displayed.
15. Initiate transmit and adjust L101 to within ± 100 Hz of test frequency.
16. Return the radio to normal operation.

• 70-1489 Computer Based Programmer

Refer to the 70-1489 Computer Based Programmer's Manual for more information.

1. Connect the radio to power and test equipment as described under the alignment procedure section of the service manual.
2. Connect the radio to the computer as described in the Computer Based Programmer's manual.
3. Upload the contents of the radio into the computer.

4. Enter the test mode of the program.
5. Select **RX-TX** in the TEST MODE and press **ENTER**.
6. Select **TX** in the RX-TX MODE and press **ENTER**.
7. Enter the correct RX (receive) and TX (transmit) test frequency for the radio. **NOTE:** The CTCSS/DCS tones/codes do not need to be used for this test. Do not leave the CHANNEL DATA FORM screen at this time.
8. Measure the temperature of the body of R107 using a contact type thermometer. You must hold the thermometer on R107 for at least one minute before taking the temperature reading. R107 is located under the VCO shield (see Figure 2 - 1) .
9. Determine the type of crystal the radio has installed as shown in Figures 2 - 1 and 2 - 2.
10. Using a digital voltmeter, measure the DC voltage on pin 60 of the microcomputer.
11. Find the measured temperature of R107 in Table 2 - 4 and find the corresponding voltage for the type of crystal installed. Compare this voltage to that measured in step 10. If the voltage is within 0.02 volts DC, then return the radio to normal operation. Otherwise:
12. Press **ESC** then **ENTER**.
13. Select **TX-CONTROL** in the TX MODE and press **ENTER**.
14. Use the **DOWN** arrow to select **CRYSTAL TYPE** and press **ENTER**. This will open the choice window.
15. Select the correct crystal type that the radio has and press **ENTER**.
16. Use the **UP** arrow to select the **REFERENCE FREQUENCY ADJUSTMENT**.
17. Using the **F5 — F8** keys, adjust the voltage to within 0.02 V DC of the voltage determined in step 11. The typical setting of the **REFERENCE FREQUENCY ADJUSTMENT** should be between 30 — 40. Press **ENTER** after each entry of the **F5 — F8**. After completion of the adjustment of the voltage on pin 60 of the microcomputer, press **ESC**.
18. Select **SAVE-TX** in the TX MODE and press **ENTER**.
19. Initiate transmit and adjust L101 to within ± 100 Hz of test frequency.
20. Return the radio to normal operation.

RECEIVER ALIGNMENT

1. Change the RX test frequency to 33.1 MHz for A-Band, 39.1 for B-Band, or 46.1 for C-Band.
- **First Injection**
 - 2. No adjustment for first injection is required.
- **Preselector Alignment**
 - 3. No adjustment for the preselector (L201, L202, L203, L204, L205, L206, L207, and L208) is required.
- **Quadrature Detector**
 - 4. Apply 1 mV of modulated (by 1 kHz tone at ± 3 kHz deviation) on-channel RF signal to Antenna Jack J502. Adjust Detector L250 for maximum audio output.
- **First IF**
 - 5. Apply enough modulated (by 1 kHz tone at ± 3 kHz deviation) on-channel RF signal to maintain 12 to 15 dB SINAD. Adjust L245, L247, L803 and L804 for maximum SINAD, reducing the RF signal generator output as necessary to stay between 12 and 15 dB SINAD.
- NOTE:** Do not adjust L801 or L802 unless appropriate test equipment is available for performing the "Noise Blanker Tuning" steps below. Normally, these coils are tuned for optimum sensitivity as are L803 and L804, then are retuned slightly for optimum noise blanker effectiveness. If the required test equipment is not available, skip steps 6

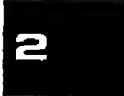

PREPARATION

70-0371/0375

Table 2 - 2 — Noise Blanker Test Equipment (Method 1)

TEST INSTRUMENT	CAPABILITIES	SUGGESTED MODEL
Pulse Generator	Pulse Rate: 5000 pulses per second Pulse Width: Adjustable to 10 ns at 1/2 amplitude. Output: Continuously variable from 0.1 to 10 V peak into 50 Ω	Hewlett Packard 8012B or similar
Power Divider, 3 port:	50 Ω each port, 6 dB attenuation, DC to 50 MHz as defined in EIA Standard RS-204C or RS-204D Appendix A.	Mini-Circuits model 2FRSC-2050 or similar

through 14. If coils L801 or L802 were replaced, they may be tuned for best sensitivity after adjustment of L245, L247, L803 and L804. Noise blanker performance specifications, however, may not be met.

• Noise Blanker Tuning — Method 1

This procedure requires the additional test equipment shown in Table 2 - 2. Refer to Method 2 if you do not have access to a pulse generator.

1. Adjust the pulse generator to obtain a 10 nsec wide pulse, as shown in Figure 2 - 2. Set the pulse period controls to obtain 200 μ sec between pulses (the pulse period is easier to observe on an oscilloscope if the pulse width is temporarily increased by about 10 times).
2. Temporarily disable the pulse generator.
3. Using coax cable of minimum convenient length, connect the pulse generator, the RF signal generator, and the radio to the two-way power divider.
4. Disable the noise blanker by placing SW801 to the OFF position.
5. Apply an on-channel signal to obtain 12 dB SINAD, then increase the RF generator output by 40 dB.

6. Enable the pulse generator to produce the 10 nsec pulses. Adjust pulse amplitude to return SINAD reading to 12 dB.
7. Switch SW801 to the ON position. The SINAD reading should improve.
8. Reduce the RF generator output until a 12 dB SINAD reading is obtained.
9. Using a non-metallic tuning tool, slowly tune L801 (clockwise or counter-clockwise, as required) for best SINAD. The amount of L801 adjustment required should be slight. Tune L802 in the same manner. Repeat this step. Noise Blanker tuning is complete.

• Noise Blanker Tuning — Method 2

Perform the following test procedure if you do not have access to a pulse generator. Please note, however, Method 1 is the more accurate test method.

1. Apply an on-channel signal to obtain 12 dB SINAD.
2. Switch SW801 to the ON position.
3. Using an oscilloscope or DC-Voltmeter, monitor test connector CM201 pin 1. Using a non-metallic tuning tool, slowly tune L801 for a peak in DC voltage (see Figure 2 - 2 for the location of CM201). This completes Noise Blanker tuning.

• **Tight Squelch**

4. Set the front panel Squelch control to maximum (full clockwise). Set Squelch Range RV241 fully counter clockwise.
5. **If filter FL801 has been removed from your radio:** Apply $0.4 \mu\text{V}$ of unmodulated on-channel RF signal to the $50\text{-}\Omega$ antenna connector.

For all other radios: Apply $1.5 \mu\text{V}$ of unmodulated on-channel RF signal to the $50\text{-}\Omega$ antenna connector.
6. Adjust Squelch Range RV241 clockwise until squelch just opens (audio on).

CTCSS/DCS (If Installed)

1. Enter DCS code +023, and adjust VR1 so that DCS deviation is at $0.75 \pm 0.1 \text{ kHz}$.
2. While observing recovered modulation on an oscilloscope, fine tune RV401 for a square DCS waveform as shown.
3. Readjust DCS deviation to $0.75 \pm 0.1 \text{ kHz}$.
4. Set frequency to CTCSS at 250.3 Hz. Adjust RV401 for $0.75 \pm 0.1 \text{ kHz}$
5. Repeat step 2.
6. Check CTCSS so that deviation is in 0.6—0.9 kHz range.

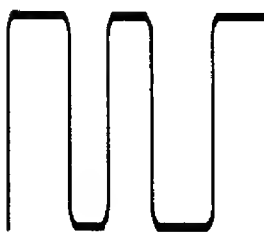

CORRECT

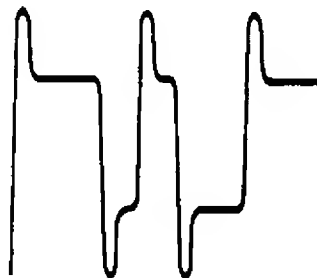

INCORRECT

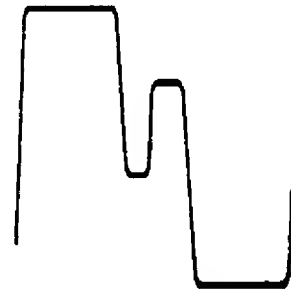

INCORRECT

PREPARATION

70-0371/0375

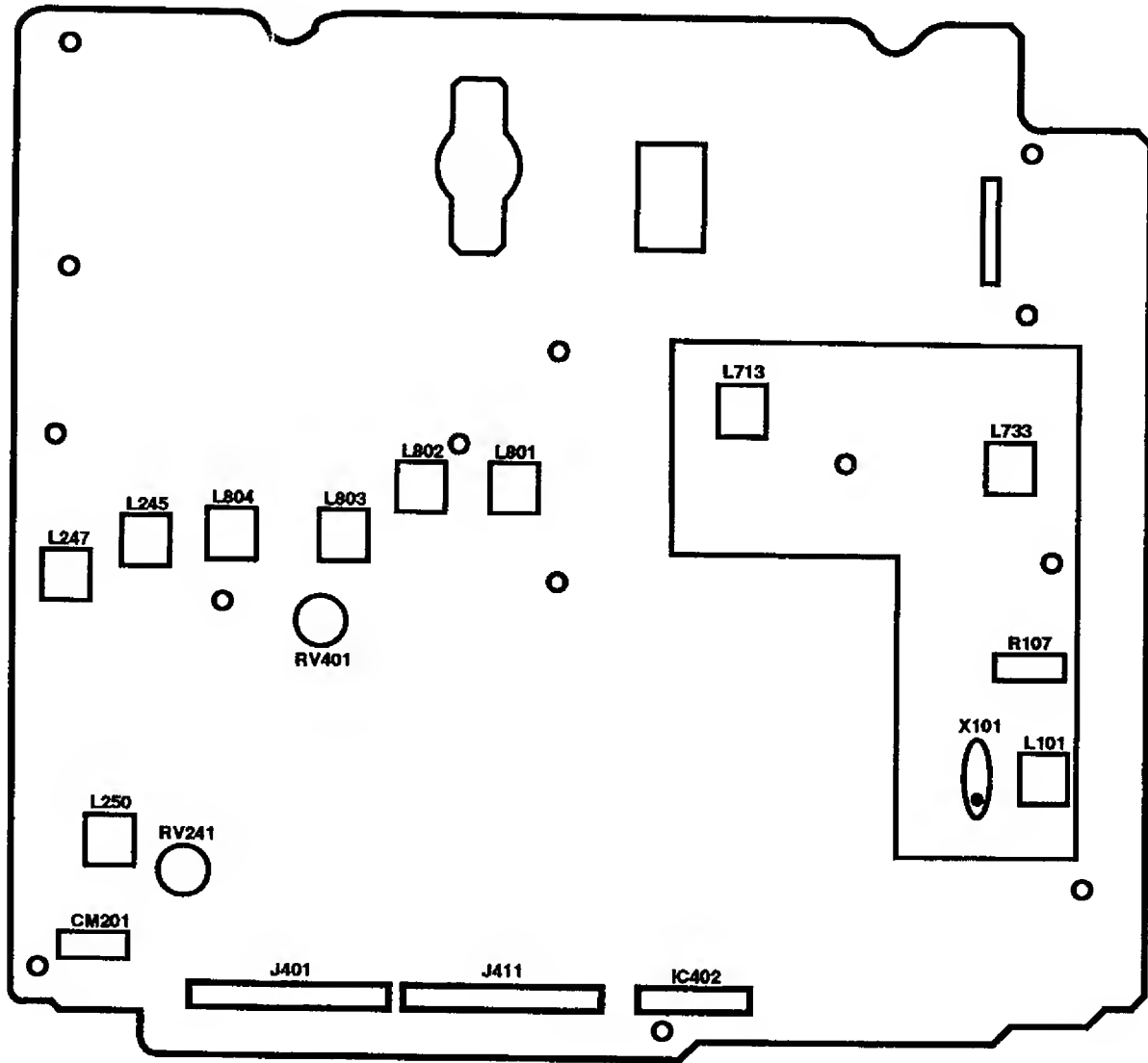
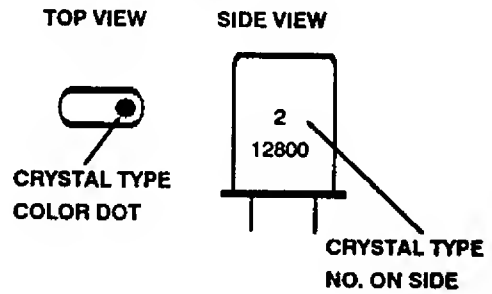

Figure 2 - 1 Adjustment Map — TR-053 Board

Table 2 - 3

CRYSTAL TYPE	I	II	III
CRYSTAL TYPE COLOR OF DOT ON TOP	BLACK	BLUE	RED
CRYSTAL TYPE TYPE NO. ON SIDE	1	2	3
TYPE NO. TO ENTER IN PROG MODE	1	2	3

Figure 2 - 2



2

Table 2 - 4

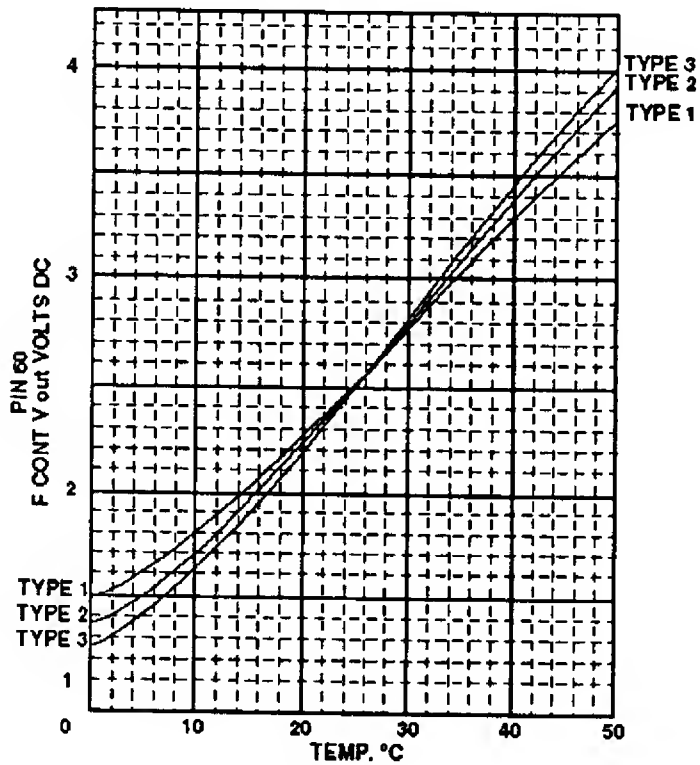

PREPARATION

70-0371/0375

NOTES

SECTION 3

INSTALLATION

INSTALLATION

70-0371/0375

NOTES

INSTALLATION

MOUNTING

• **Under-dash**

The 70-0371A/B/C mounting bracket slides into the transceiver siderails and provides a 3.25" x 7.75" flat surface across the transceiver top with holes for bolting to a flat surface in the vehicle. 5/32" holes must be drilled in the mounting surface to accept the four 3/8" screws and washers provided.

• **Trunk-Mount**

The operator controls for the 70-0375A/B/C transceiver are inside a compact control head for operator access, while the bulk of the transceiver is located in a separate remotely mounted unit. It does not have an internal speaker. Instead, a separate 3.2 Ω external speaker (included with the 70-0375 package) must be installed and connected to the Control Head.

The cable that interconnects the Control Head to the trunk unit is four meters long and flat for laying under carpeting. The cable must not lay near hot areas (above the catalytic converter, for example), or against sharp edges.

A trunk unit mounting tray is provided with each transceiver. The flat tray is 7.5" square and must be bolted to surface where the trunk unit will mount. 5/32" holes must be drilled in the mounting surface to accept the four 3/8" screws and washers provided. The 13" x 8" x 3" trunk unit then clips onto the tray.

A Control Head mounting bracket is provided with each transceiver. Its surface is 3/4" wide and 4" long with two screw holes 2" apart. 5/32" holes must be drilled in the mounting surface of the vehicle to accept the 3/8" screws and washers provided. The Control Head and Bracket assembly is 2 1/2 inches deep. At least 3/4" of additional depth is needed for

the connectors that attach to the rear of the Control Head.

POWER

• **Connections**

For Under-Dash units, the Power Cable is equipped with two unterminated 10 gauge wires two meters in length for connection to the vehicle electrical system. For Trunk-Mount units, the Power Cable is equipped with two unterminated 10 gauge wires six meters in length. These lengths will be sufficient for direct connection to battery.

Connect the black wire to the negative (-) chassis ground of the vehicle. Because this radio draws such a large current (25 A), the black wire should be connected directly to the battery. **NOTE: DO NOT ATTEMPT TO INSTALL THE TRANSCEIVER IN A POSITIVE GROUND VEHICLE.**

Connect the red wire to the positive (+) side of the vehicle electrical system. Because of current requirements, connection to an existing fused circuit should be avoided to prevent overload of that fuse. This wire has its own in-line fuse for protection against wire penetration and transceiver defect. If you wish for the radio to turn on when ignition is engaged, you must install an ignition relay. The 70-2218 Ignition Relay Kit can be purchased for this purpose.

• **Requirements**

Both the 70-0371 and 70-0375 transceivers are designed to operate from a 12 V DC negative ground automotive electrical system. Current drain of at least 25 A should be expected. Inspection of the vehicle is recommended prior to installation. A low battery or other electrical system defects may degrade transceiver performance.



INSTALLATION

70-0371/0375

CAUTION: Check the voltage source before connecting the power cable. Too much voltage (above 16 V) can severely damage the transceiver.

Included with the trunk-mount transceiver is a 6 m power cable. The under-dash transceiver is shipped with a 2 m Power/Accessory cable. Each cable includes fused power leads for connection to vehicle electrical system. Because the transceiver chassis is connected to the negative (-) lead, **DO NOT INSTALL THE TRANSCEIVER IN A POSITIVE GROUND VEHICLE.** If the transceiver is used as a base station, the external AC-line-to-DC power supply must be adequately regulated and have sufficient current capacity.

ANTENNA

The communications system component that can affect overall performance the most is the antenna. A good quality antenna designed to provide 50 Ω terminating impedance at appropriate transceiver frequencies is recommended. When adjusting the antenna, be sure to follow its manufacturer's instructions. A better quality SWR meter should be used to accurately measure minimum reflected energy.

MICROPHONE HANGER

The hand microphone included with the transceiver has a button on its backside to mate with its hang-up clip. The clip must be mounted with three screws in a location convenient to the operator. Three 1/2" screws and three 3/4" screws, each requiring a 5/64" hole, are also provided.

An optional microphone hanger (model 70-2195 for T/M radios, or 70-2195B for U/D radios) is available for use with the CTCSS/DCS option. This hang-up box may be installed in place of the microphone clip on both metallic or non-metallic surfaces.

POWER ACCESSORY PLUGS

• Under-dash

A 12-pin male Molex connector mates to the accessory connector (J415) on the rear of the 70-0371.

Extra pin positions are used for connection of optional devices not included with this assembly.

Optional devices can be connected to the Accessory Plug by inserting Molex pins included with these devices into their respective vacant holes. See **Figure 3 - 1.** Option connections are shown in lighter shade.

• Trunk-mount

The 70-0375 has one 12-pin and one 9-pin male Molex receptacles: J415 on the trunk unit; J324 on the control head. The Accessory Plug includes a jumper between pins 5 and 6 that routes speaker audio to the control head.

The 9-pin Accessory Plug connects to the rear of the control head. The speaker has Molex pins that insert into this plug. Extra pin positions are present for connection of the optional 70-2195 switching hang-up box (not included with the standard transceiver) for use with CTCSS or CDCSS. Two more pin positions are provided for optional auxiliary connections. See **Figure 3 - 2.**

EXTERNAL SPEAKER

• Under-dash (Model 70-2355)

Normally, the transceiver internal speaker is connected to receive audio by the jumper to pins 5 and 6. If one of the MIDLAND external speakers is to be utilized, the jumper must be removed to disable the internal speaker and the two wires from the external speaker must connect to pins 4 and 6.

NOTE: If the 70-2355 15 W External Speaker is to be connected, its input cable center conductor (white) must be connected to pin 6, and the shield (black) to pin 4.

• Trunk-mount

The 70-2355 15 W speaker comes with the standard trunk-mount transceiver configuration. It connects to the Control Head Accessory Plug. Its 5 1/2' cable is terminated with appropriate Molex pins for insertion into the trunk-mount Accessory Plug on the Control Head or the under-dash Power/Accessory Plug. The speaker housing and mounting bracket

assembly is 5" x 5" x 3", and the mounting surface is 4 1/4" x 1 1/4", with four 3/32" screw slots.

conductor of the shielded hang-up box cable connects to pin 3, the shield to pin 2.

HANG-UP BOX

If the CTCSS feature is included in the transceiver, the optional 70-2195 Microphone Hang-Up contact/switch-box is installed to unmute CTCSS squelch when the microphone is lifted. The center

AUXILIARY DEVICES

Pins 1 and 8 are available for auxiliary connections necessary with certain optional features. Wiring details for these are found in the literature for the option.

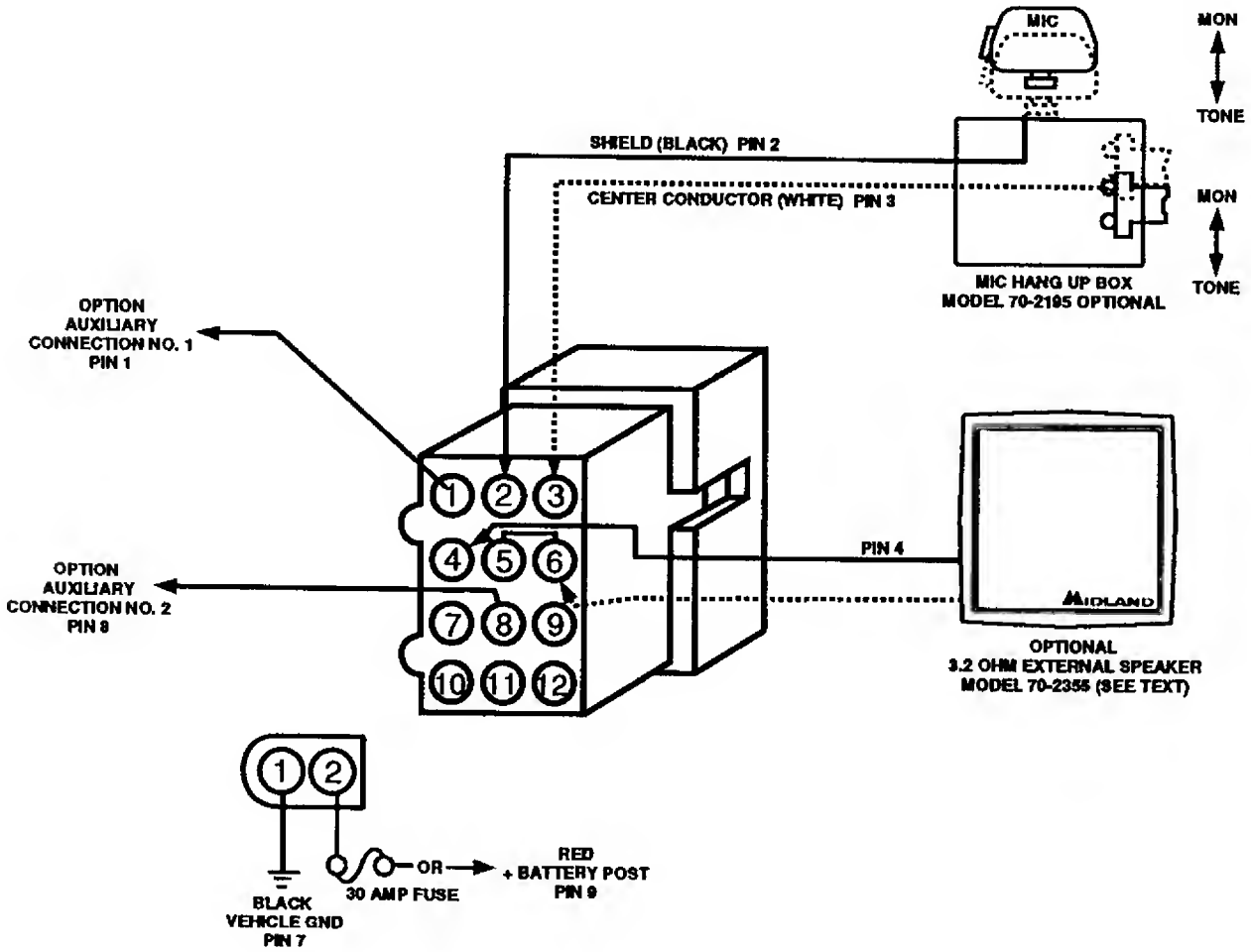

Figure 3 - 1 — Under-Dash Power/Accessory Plug

INSTALLATION

70-0371/0375

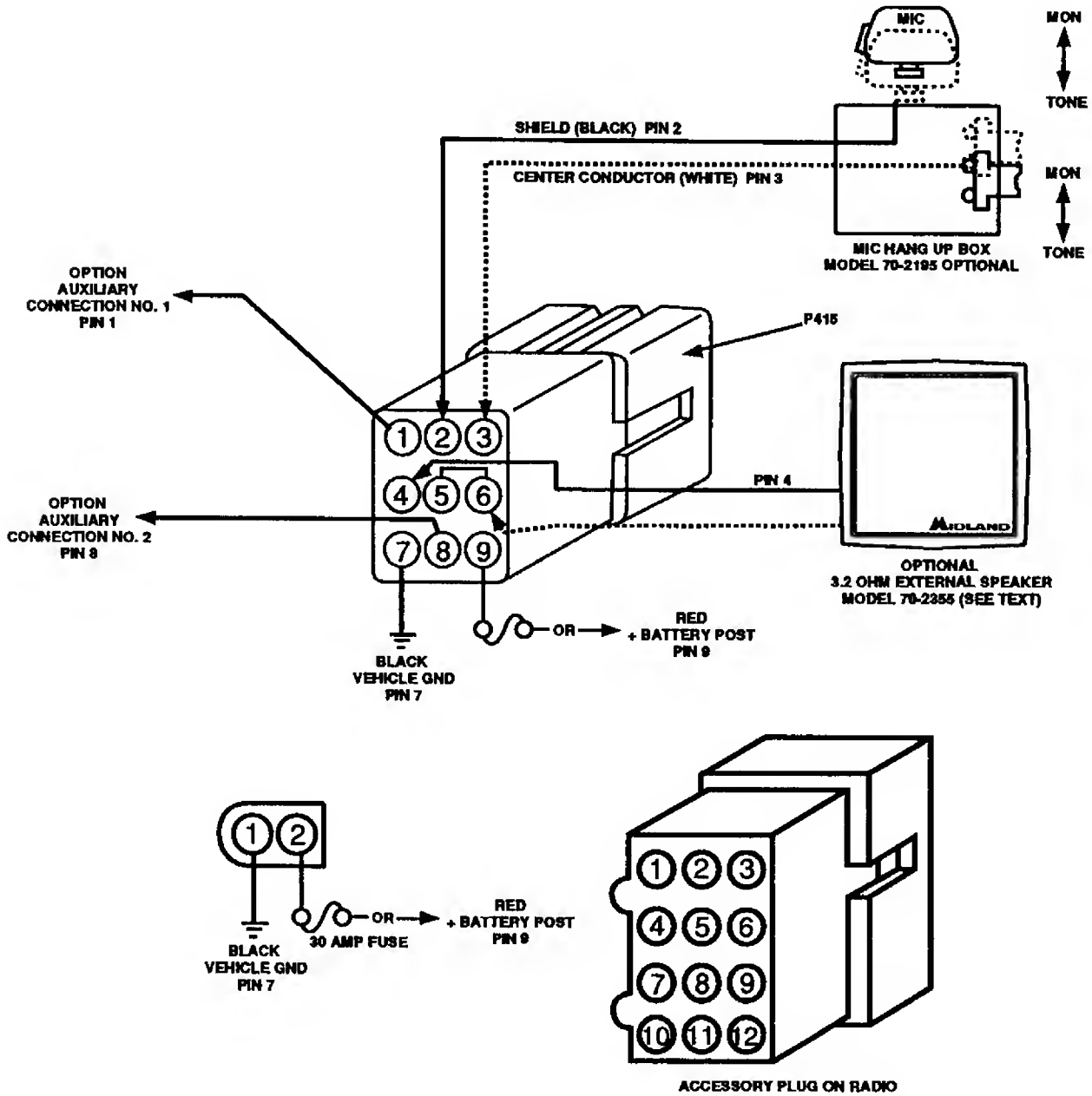

Figure 3 - 2 — Trunk-Mount Power and Accessory Plugs

SECTION 4

SERVICING

SERVICING

70-0371/0375

NOTES

REMOVING THE TR-053 BOARD

When servicing the XTR or adding option kits, you may need to remove the TR-053 Board. To do so:

1. Unscrew and remove the bottom cover.
2. Unplug J401 and J411 (for Trunk-Mount units, unplug J414 as well).
3. Under-Dash Units: Insert a screwdriver in the slot located on the Control Head above J411 and IC402 of the TR-053 Board (see Figures 4 - 1a and 4 - 1b). Pry up, then tilt the bottom part of the Control Head away from the radio chassis

Trunk-Mount Units: Remove the two screws securing the Nose-Piece (located in the handle), and pull it off.
4. Snap off the PA Section and VCO/Reference Oscillator shield covers.
5. Remove the fifteen screws securing the TR-053 Board.
6. Remove the three clips holding IC401, IC402, and IC406 to the front of the radio.
7. Lift the front part of the TR-053 Board up from the radio. Flip the board over, without removing it from the radio, in order to access its components.

The TR-053 Board is now ready for servicing.

After servicing, reinstall the board by following the following steps:

1. Lower the board back into the radio (make sure all wires are on top).
2. Insert the fifteen remaining screws, then tighten. Do not over-tighten.
3. Replace the clips for IC401, IC402 and IC406. Replace the connector plugs into J401 and J411 (for Trunk-Mount Units, also replace the brown connector plug into J414 — notice that the white connector plug is not used).
4. Replace the cover shields for the VCO/Reference Oscillator and PA Section. Make sure that you don't clamp the wires under the covers.
5. Replace the Control Head (or Nose-Piece for Trunk-Mount Units).
6. Replace the bottom cover.

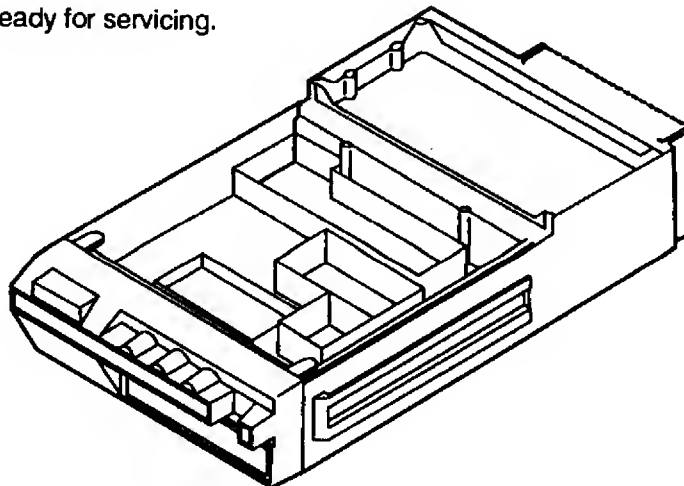

Figure 4 - 1a — SYN-TECH XTR Chassis and Control Head

SERVICING

70-0371/0375

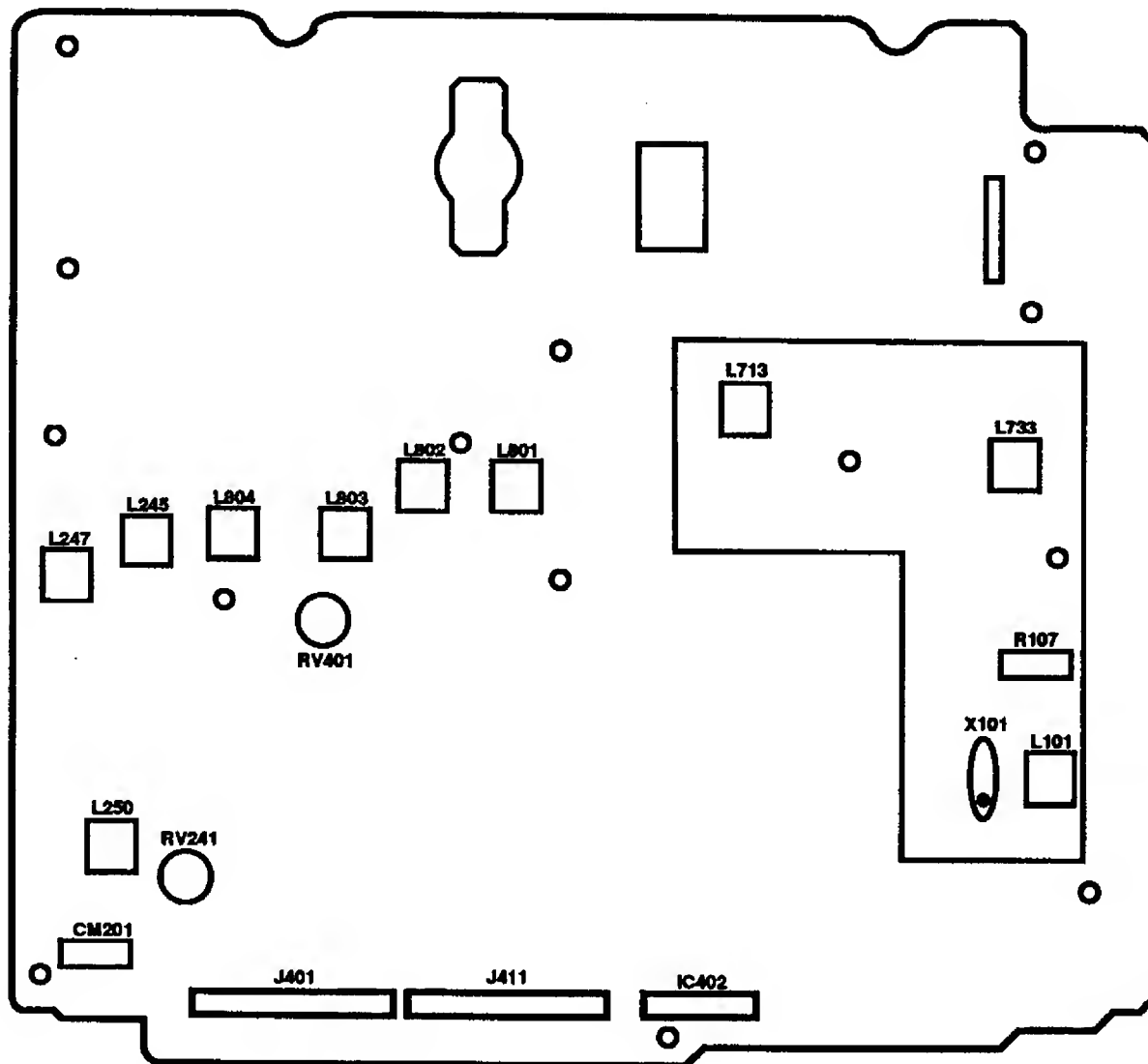

Figure 4 - 1b -- TR-053 Board

REMOVING THE PA-0502 BOARD

When servicing the Syn-Tech XTR, you may need to remove the PA-0502 Board. To do so:

1. Unscrew and remove the bottom cover.
2. Remove the black screw on the back of the radio, near Antenna Jack J502 (see **Figure 4 - 2a**).
3. Disconnect J502 by first removing the two screws securing it to the radio, then desoldering it from the PC Board. Allow J502 to fall out of the radio.
4. Remove the sixteen screws from the PA-0502 Board (see **Figure 4 - 2b**). Note that eight of the screws are of medium length, six are long, and the remaining two are short.
5. Lift the PA-0502 Board out of the radio.

The PA-0502 Board is now ready for servicing.

After servicing, reinstall the board by performing the following steps.

1. Lower the board back into the radio.
2. Replace the sixteen screws.
3. Replace J502. First screw, then solder it into place.
4. Replace the black screw on the back of the radio.
5. Replace the bottom cover.

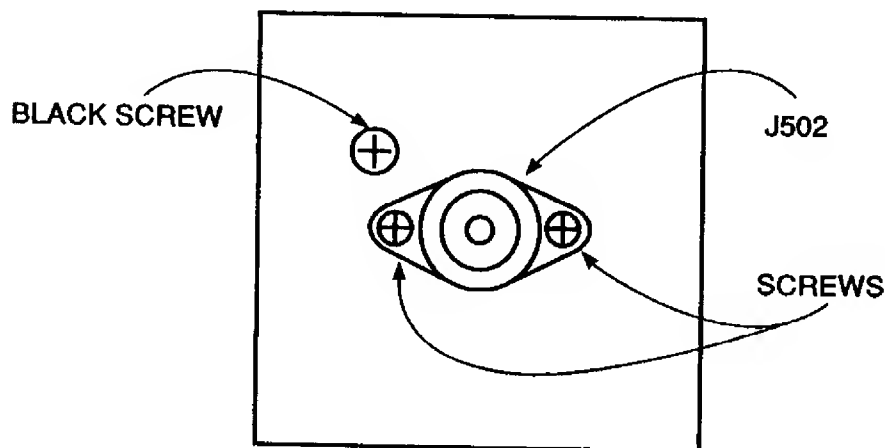
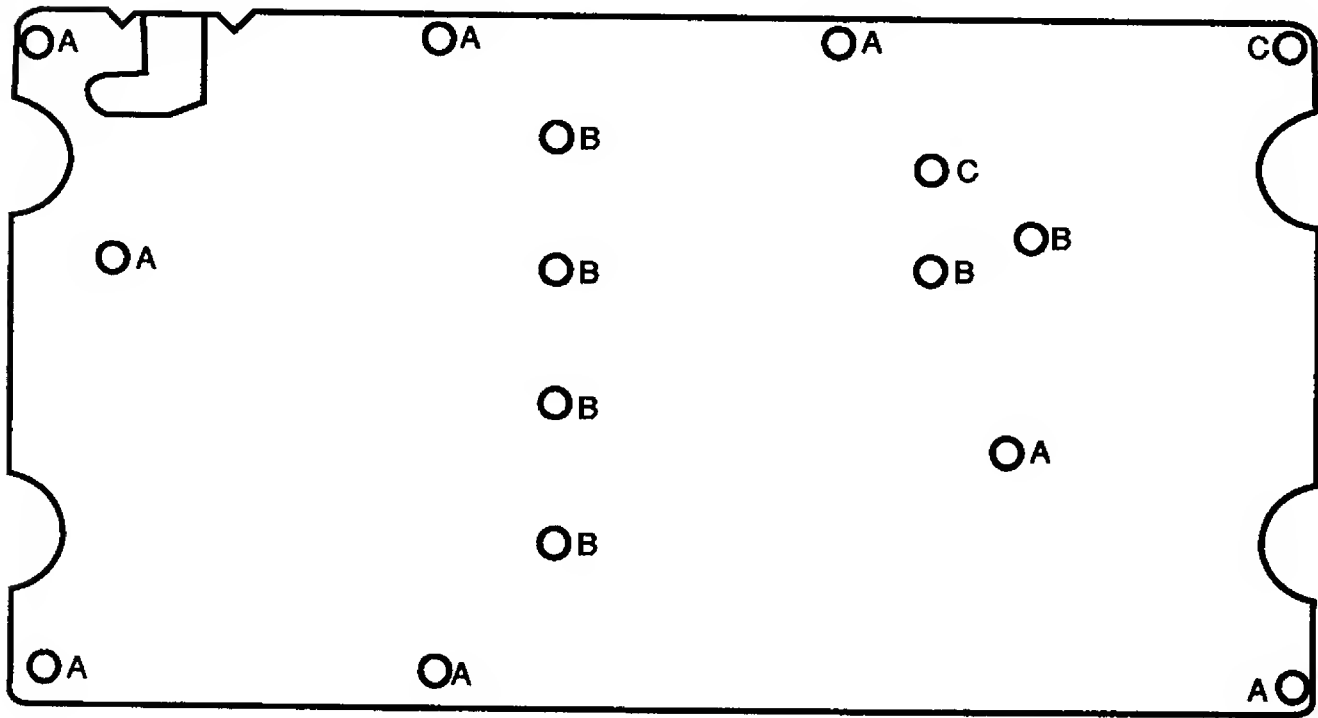

Figure 4 - 2a — Antenna Jack J502

SERVICING

70-0371/0375



A = MEDIUM

B = LONG

C = SHORT

Figure 4 - 2b — PA-0502 Board

TROUBLESHOOTING CHARTS

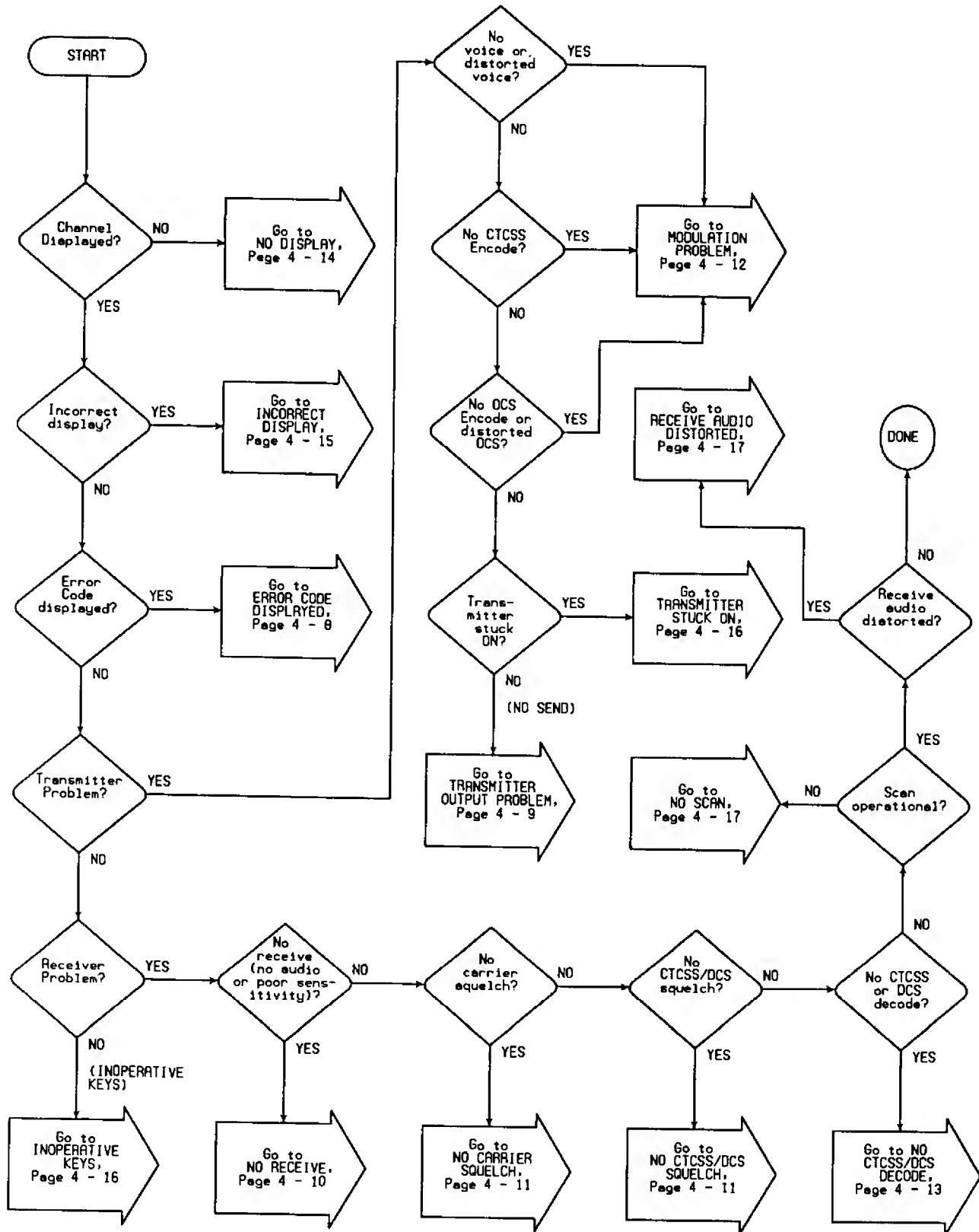

Troubleshooting Chart 4 - 1 — Getting Started

SERVICING

70-0371/0375

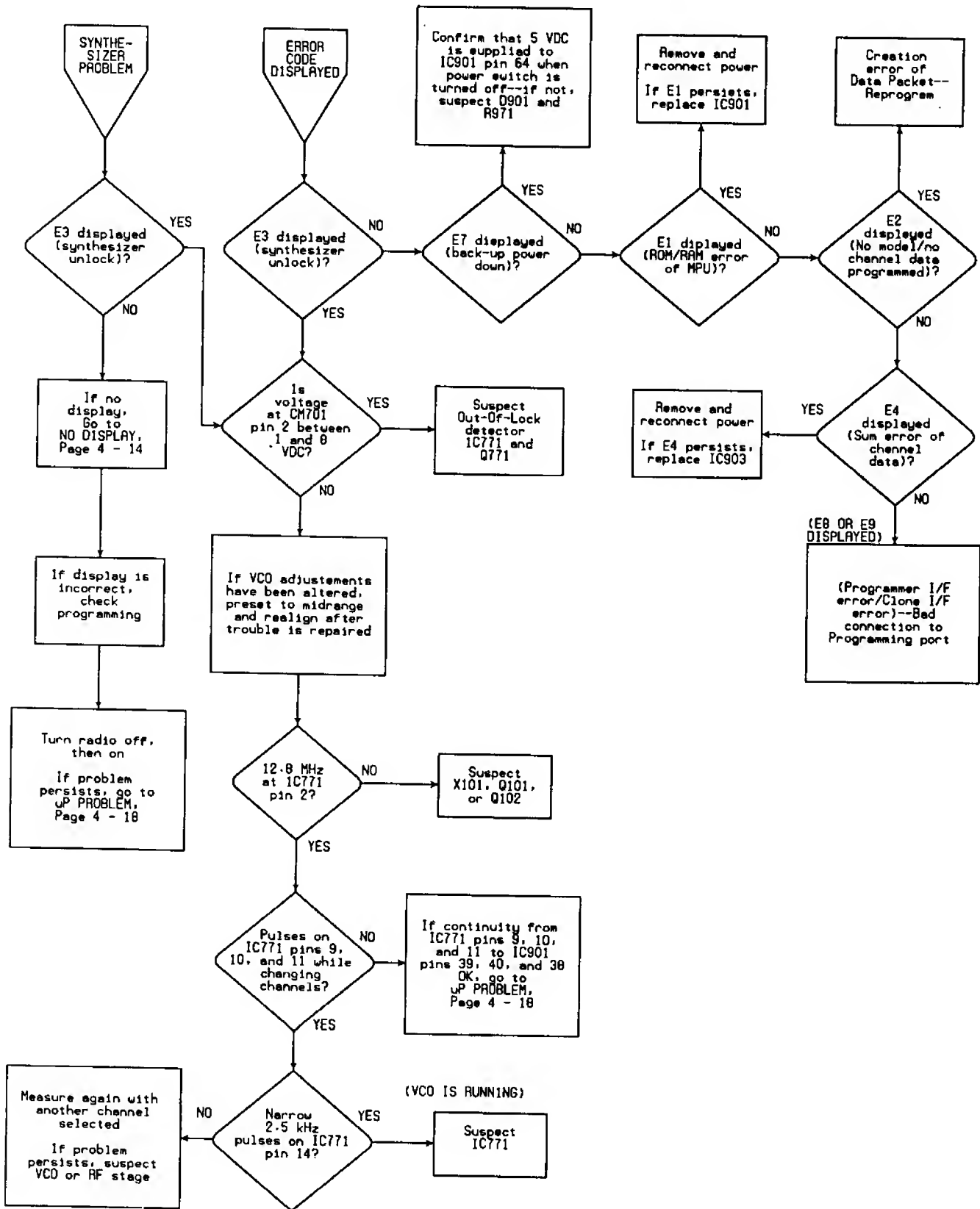

Troubleshooting Chart 4 - 2 — Synthesizer Problem/Error Code Displayed

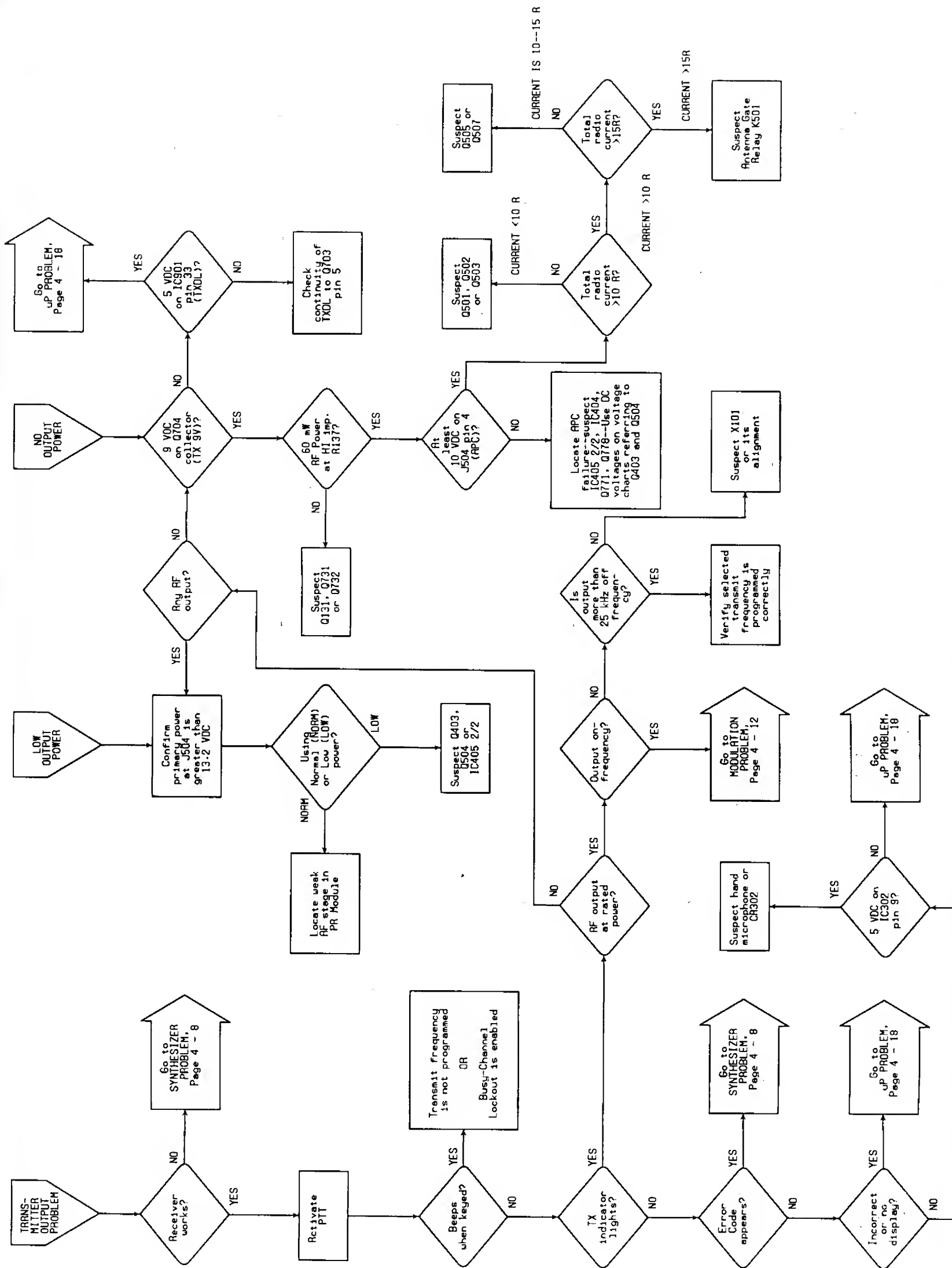

Troubleshooting Chart 4 - 3 — Transmitter Problem

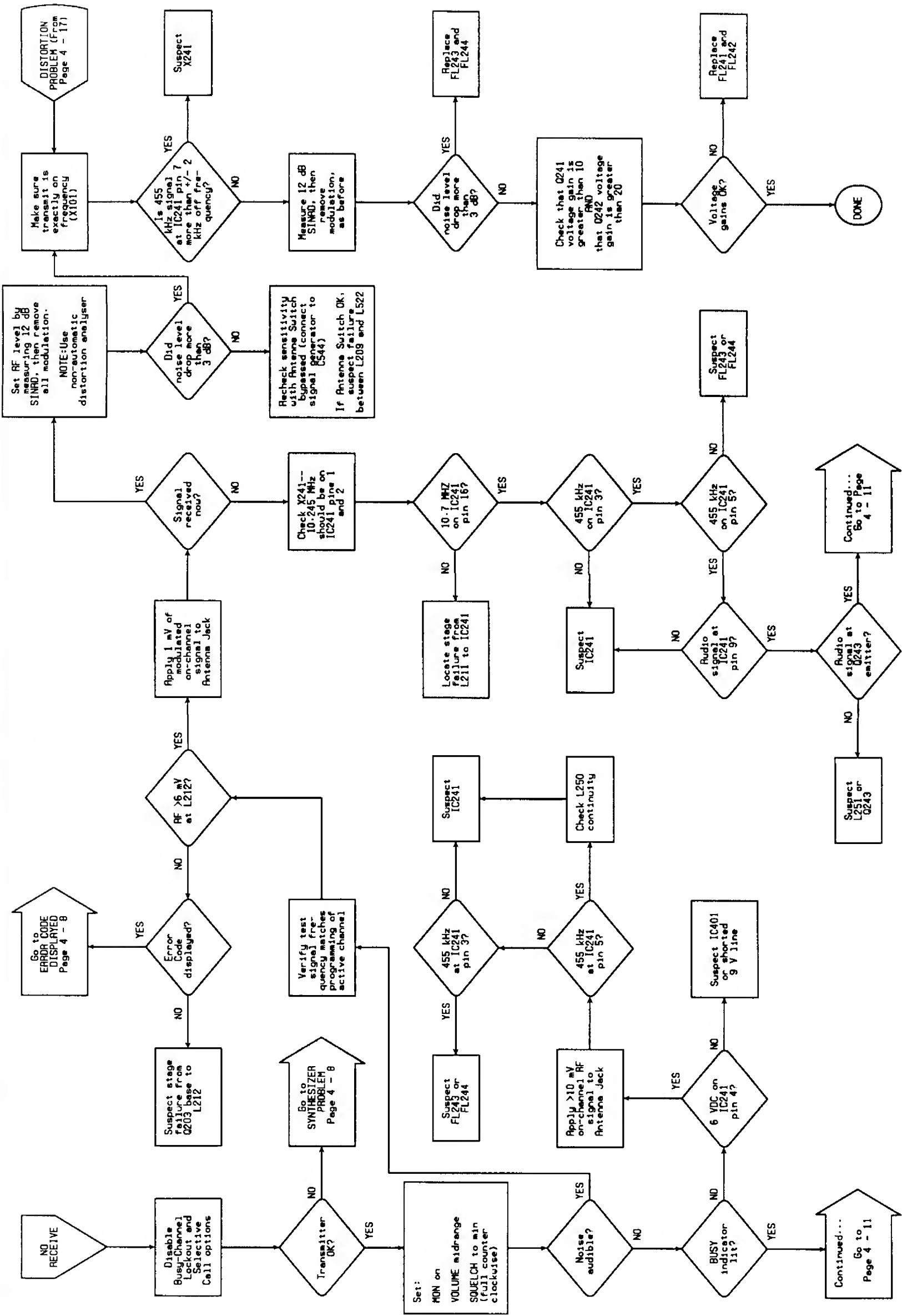

Troubleshooting Chart 4 - 4a — Receiver Problem

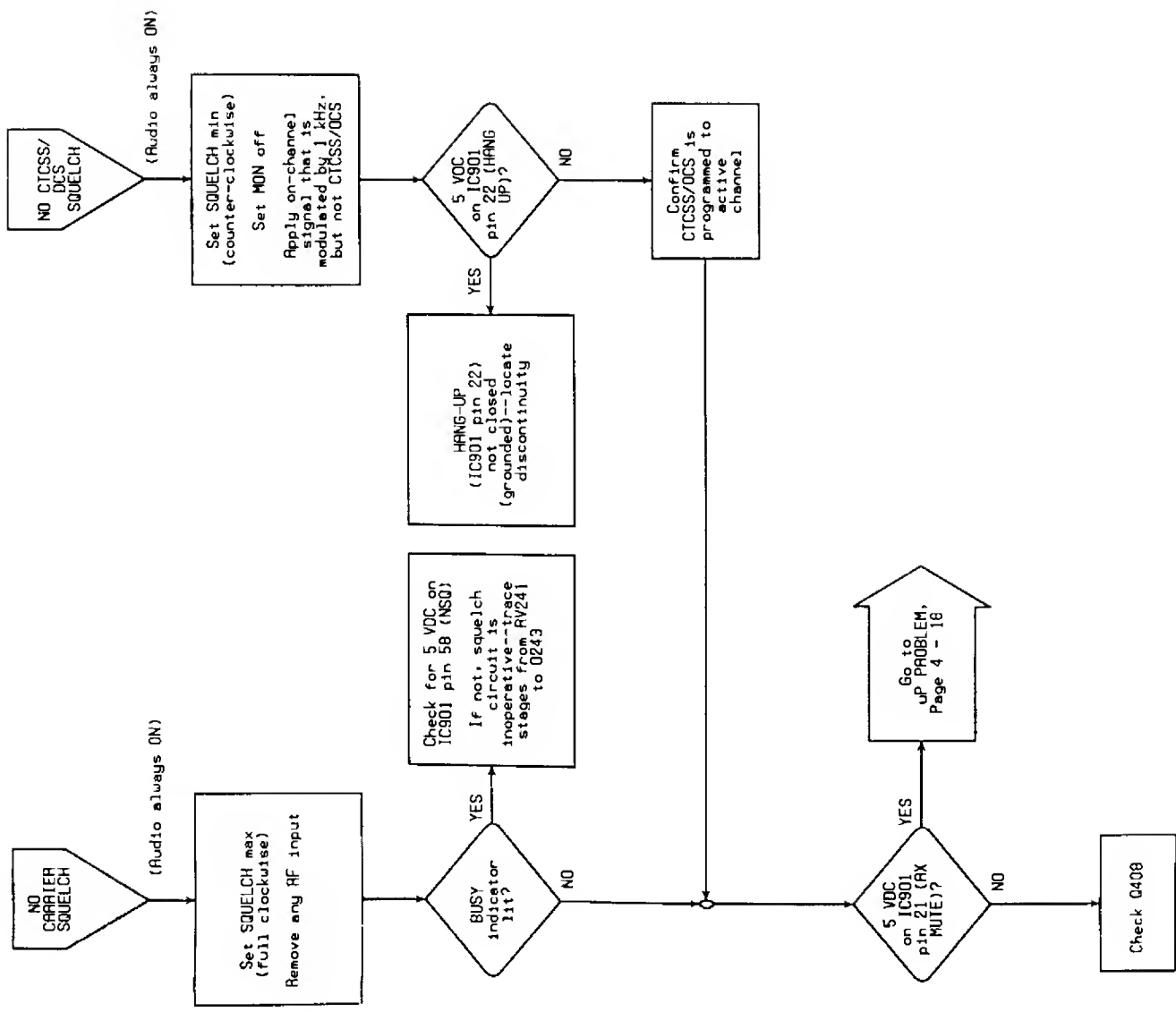
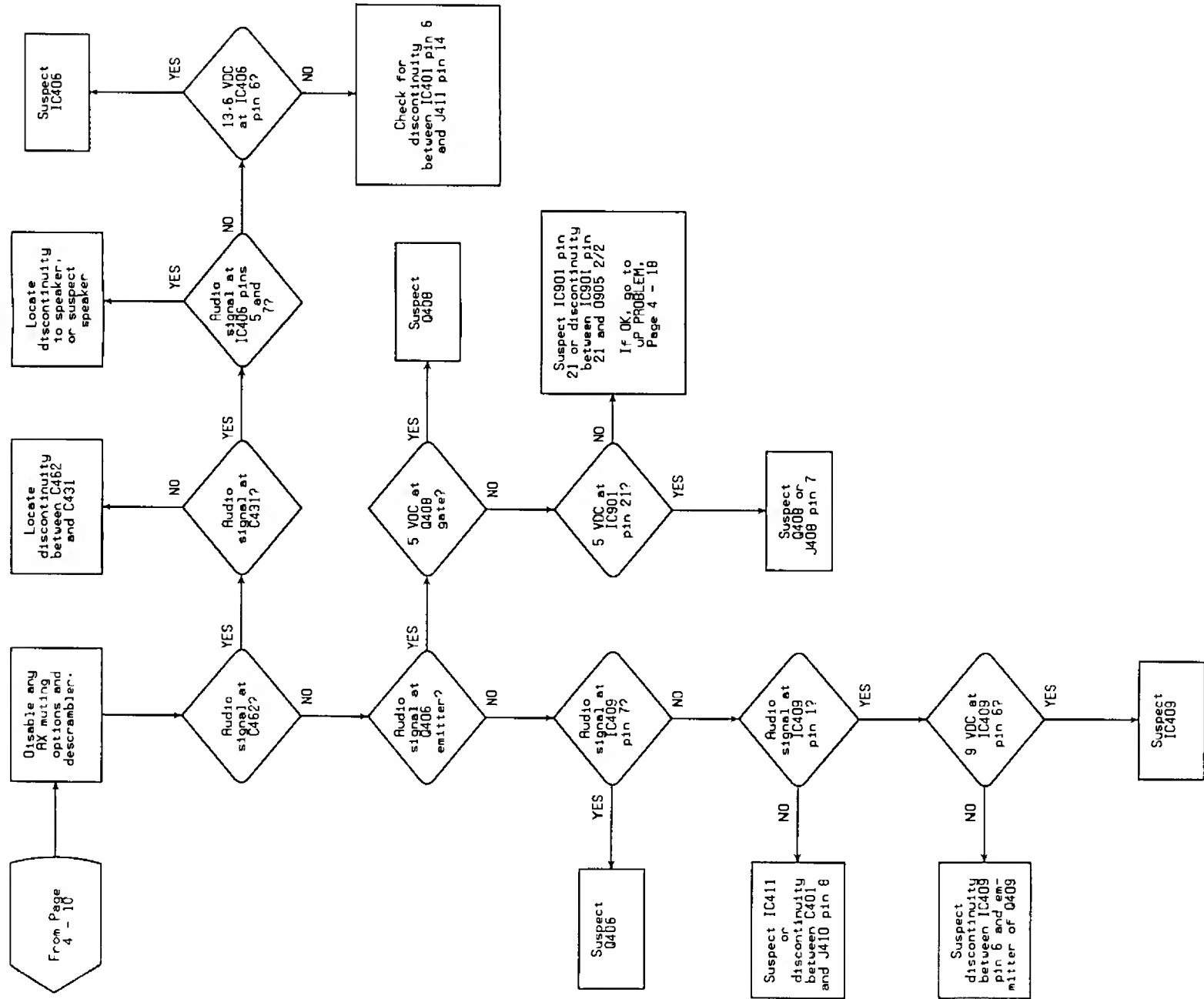

Troubleshooting Chart 4 - 4b — Receiver Problem (Continued)

Troubleshooting Chart 4 - 5 — Squelch Problem

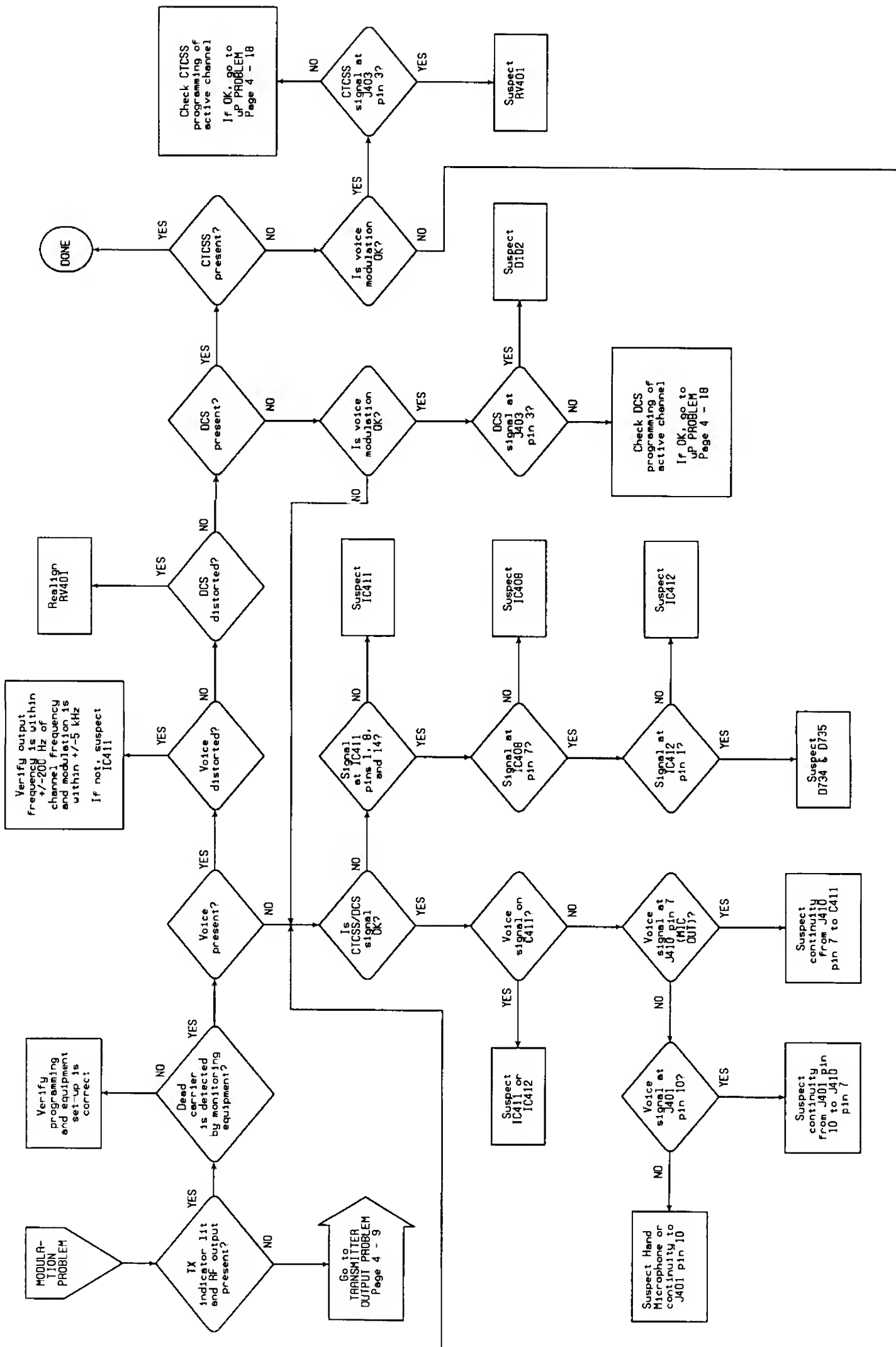

Troubleshooting Chart 4 - 6 — Modulation Problem

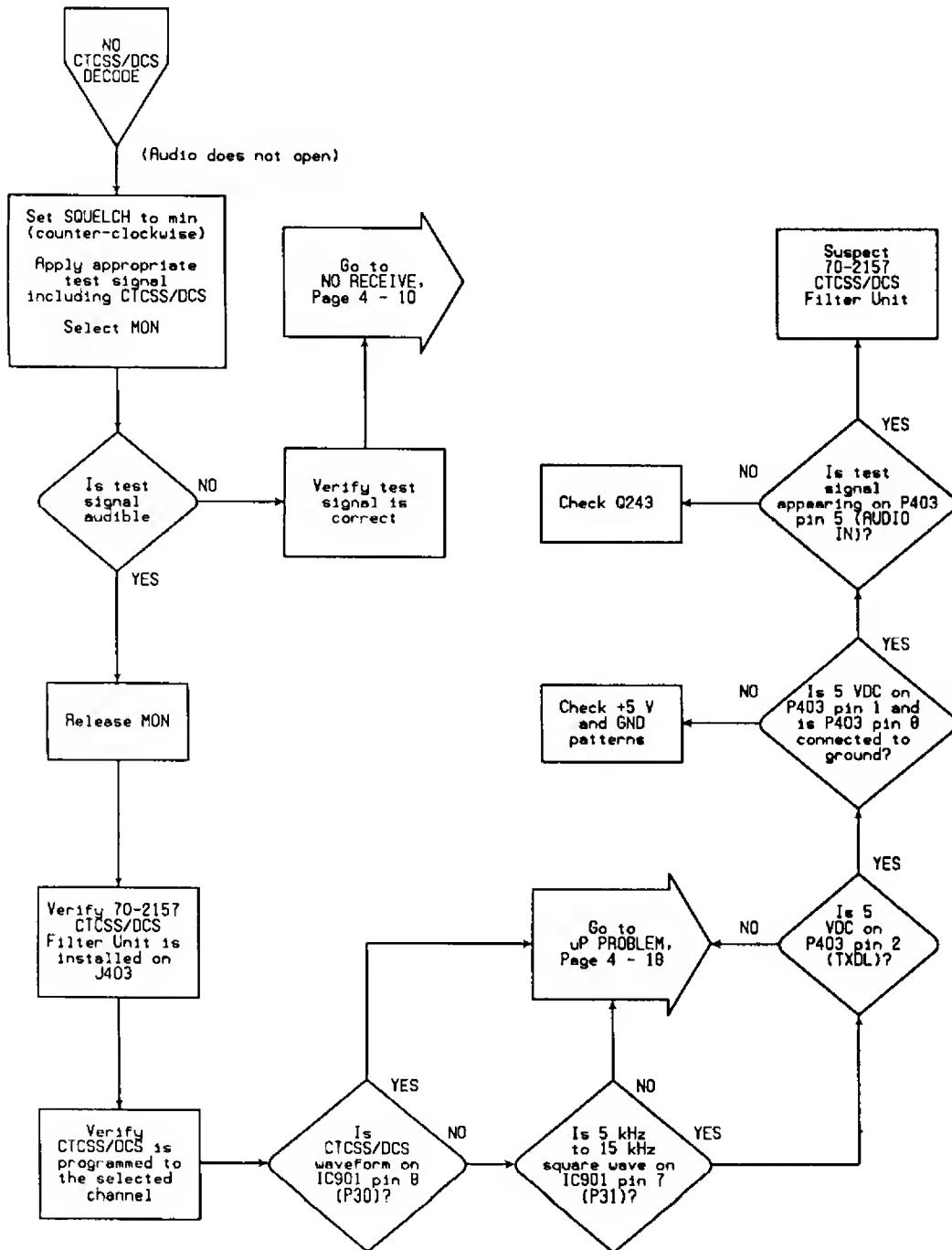

4

Troubleshooting Chart 4 - 7 — No CTCSS/DCS Decode

SERVICING

70-0371/0375

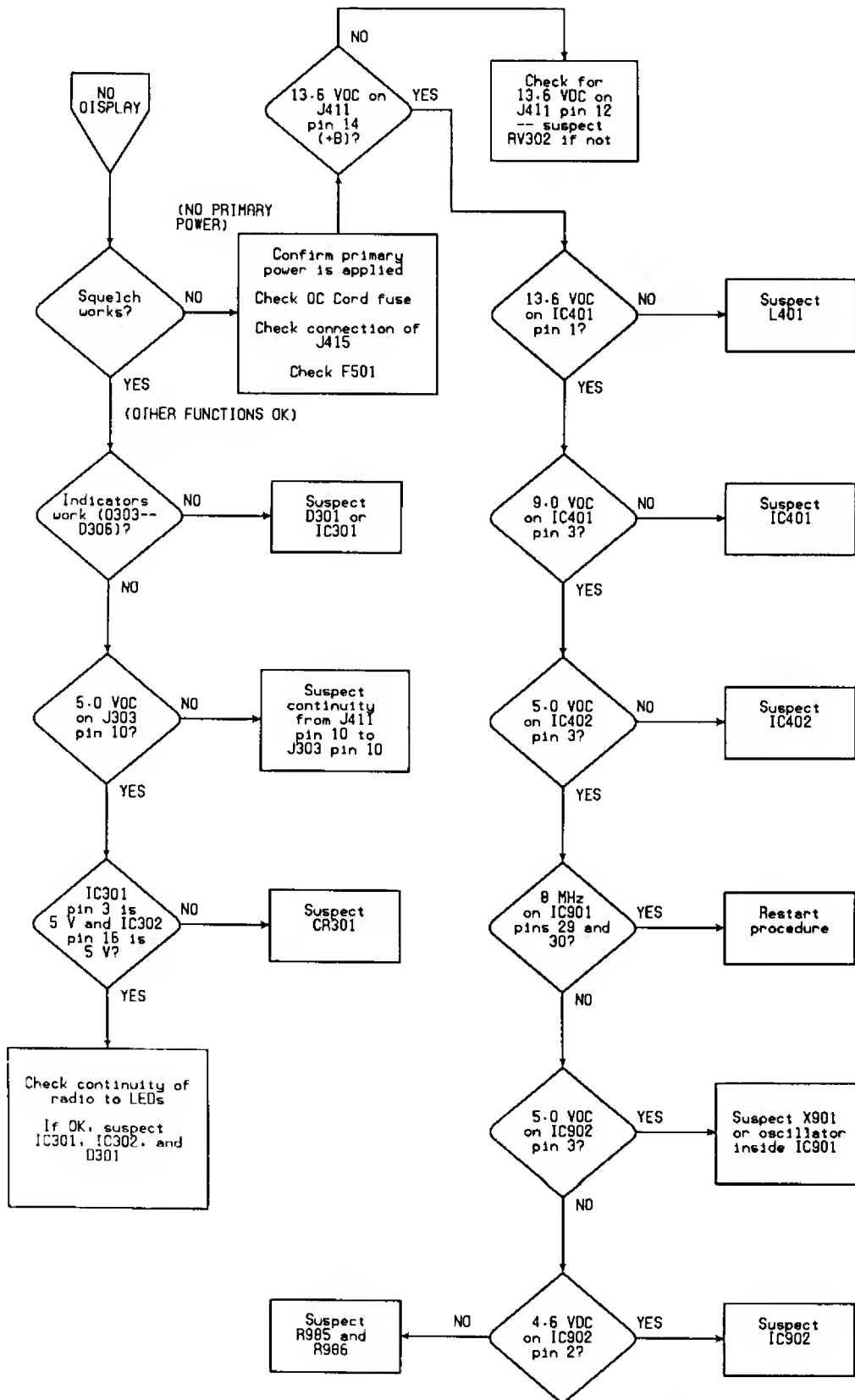

Troubleshooting Chart 4 - 8 — No Display

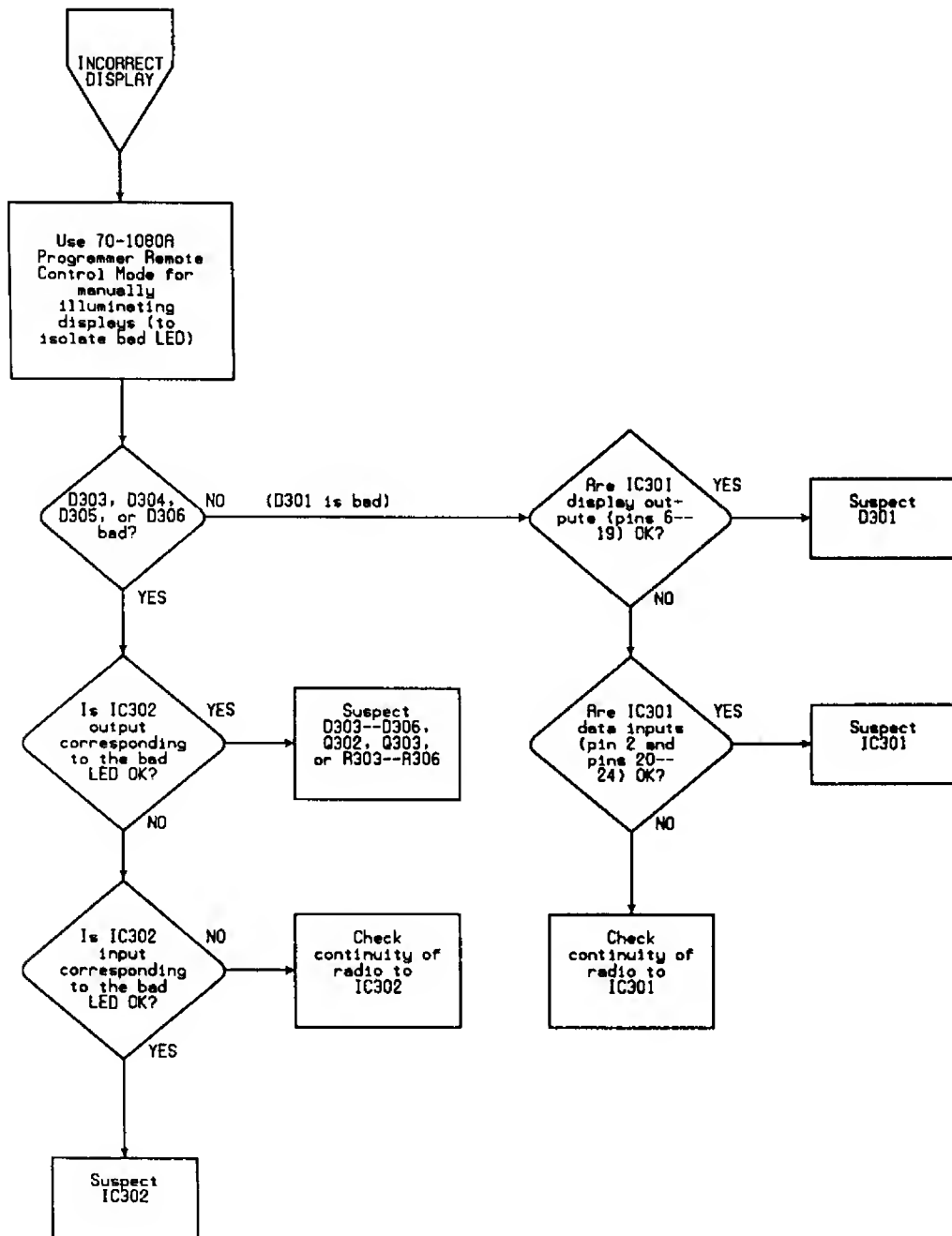

4

Troubleshooting Chart 4 - 9 -- Incorrect Display

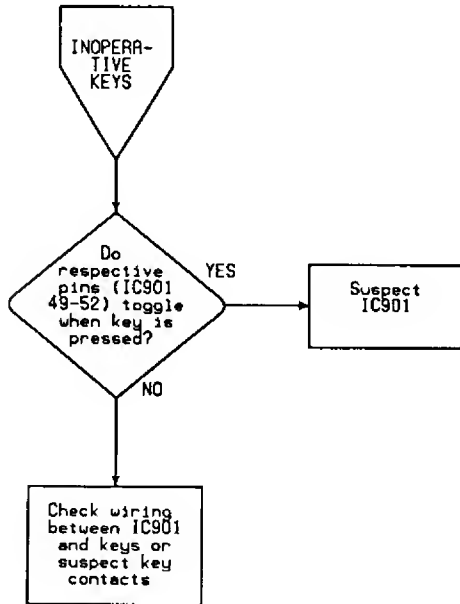

**Troubleshooting Chart 4 - 10 —
Inoperative Keys**

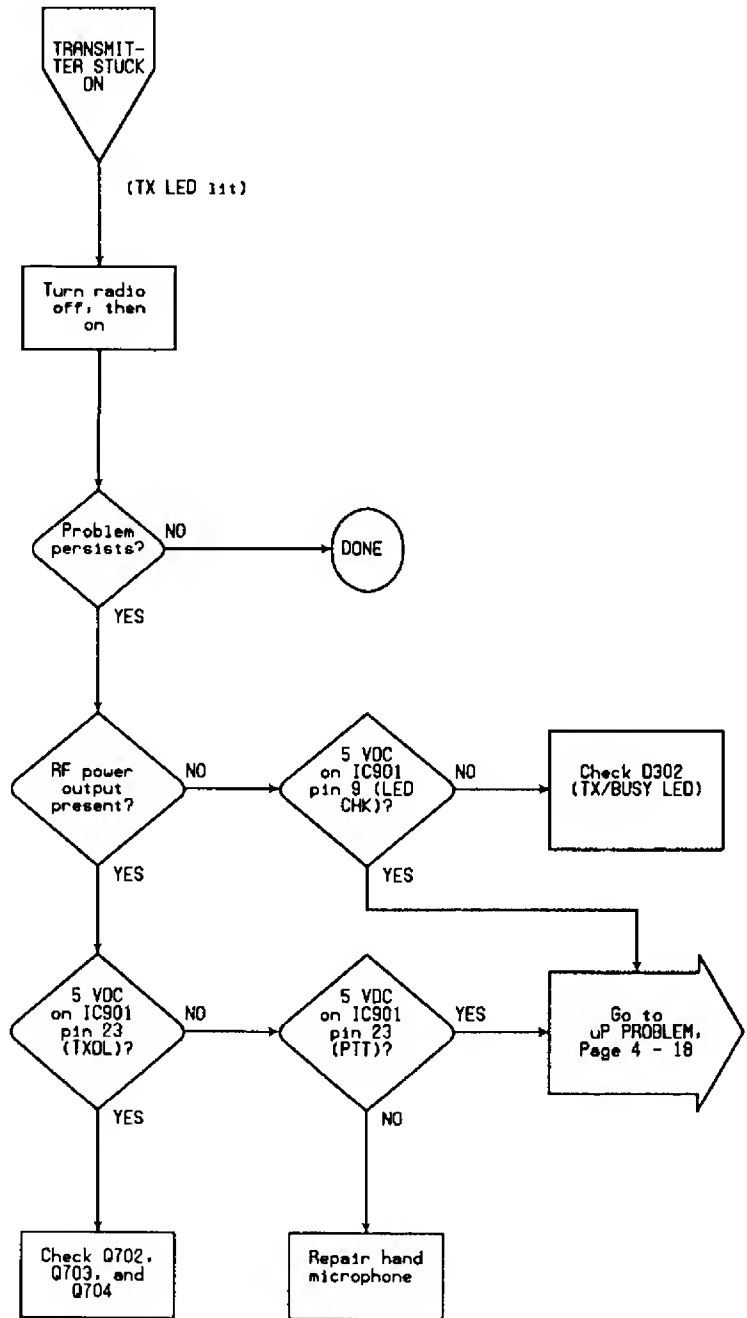

Troubleshooting Chart 4 - 11 — Transmitter Stuck On

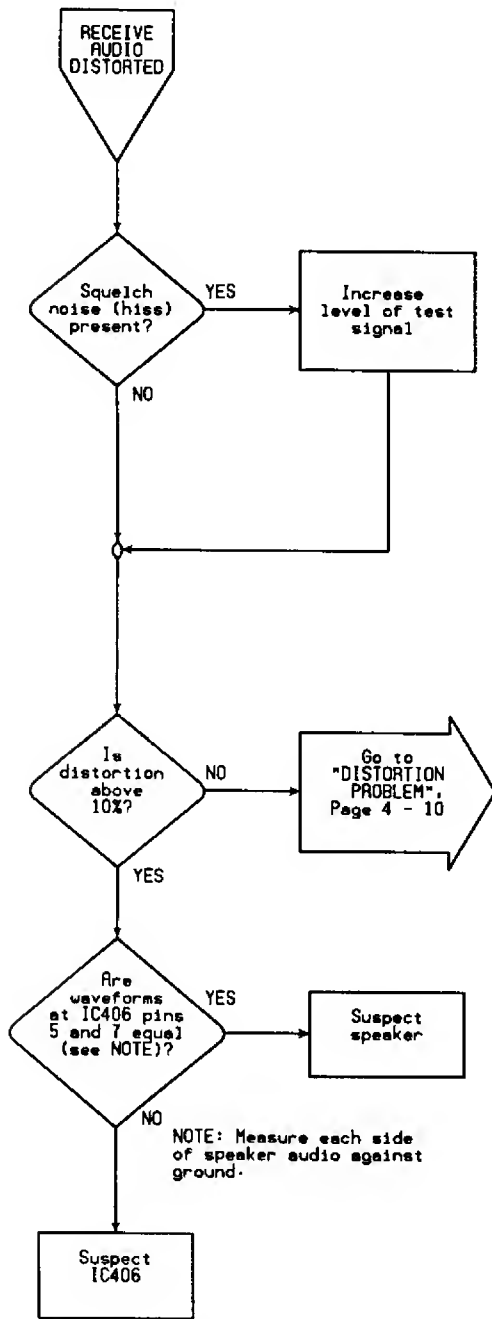

Troubleshooting Chart 4 - 12 — Receive Audio Distorted

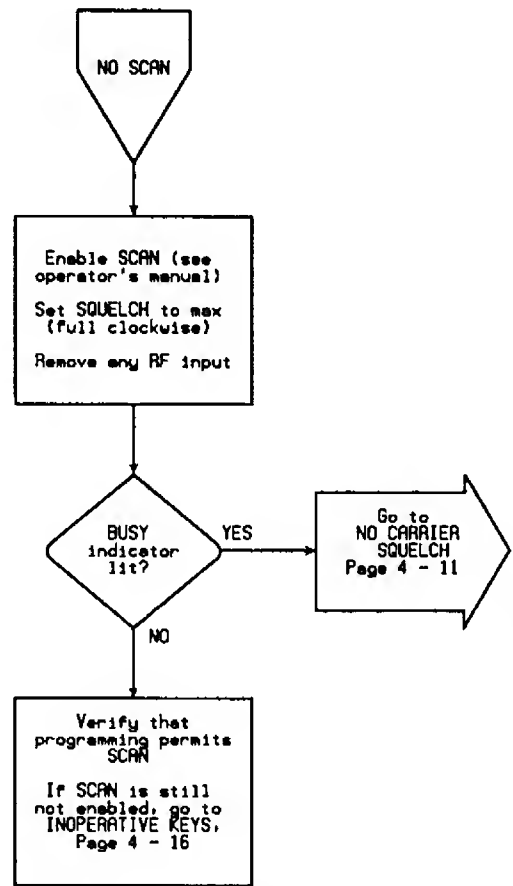

Troubleshooting Chart 4 - 13 — No Scan

4

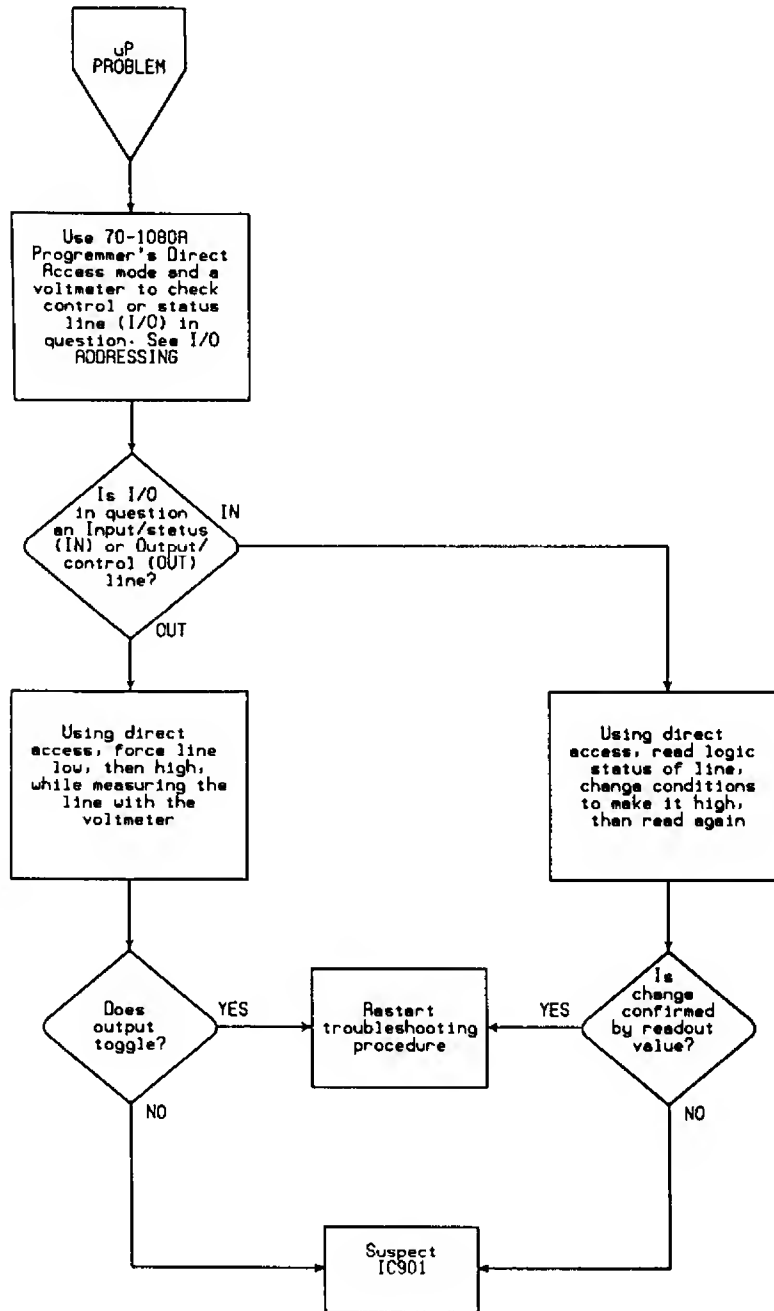

Troubleshooting Chart 4 - 14 — Microprocessor Problem

COMPONENT REPLACEMENT

STATIC POTENTIALS

Many of the transceiver components are susceptible to higher voltages whether they are in or out of a circuit. Avoid static or AC-line potentials when handling components and circuit boards. Prevent damage from electrically "hot" tips that carry AC-line or static potential by using a grounded soldering iron. The only way to alleviate risk of component damage from static discharge is to make sure all of the objects that touch the circuitry during component replacement carry the same potential. Since the soldering iron is grounded, everything else must be grounded: the bench, the equipment being worked on, and you. There usually isn't a need to wire yourself to your bench unless you work on carpeting on dry-air days. Just touch bench ground when you sit down so that you and the grounded work area are at the same potential.

REPLACING CHIP CAPACITORS AND RESISTORS

4

This section describes the best way to remove a chip component and install a new one. Chip components do not have leads, just metallic film on end-surfaces to solder to. Often the surface is tinned with solder. Because the metallic film can be easily damaged by contamination and excessive heat, these components must be soldered very carefully. No chip component can be unsoldered, then resoldered without damage. Always discard a used component.

• ITEMS REQUIRED:

- Grounded temperature-controlled soldering iron with a 1/32 inch flat-blade tip. The tip temperature must be maintained at approximately 600 degrees Fahrenheit.
- 60/40 electronics-grade solder, 22 gauge or thinner, with rosin flux.
- Tweezers or longnose pliers.
- Thin desoldering-wick.
- Isopropyl alcohol or Freon-TF for solvent.
- Rosin solder-flux. DO NOT USE ACID FLUX.

SERVICING

70-0371/0375

• **Procedure:**

1. Place the solder iron tip directly on the defective component to melt the glue under the component, then solder as shown in **Figure 4 - 2**. Remove the component with tweezers or longnose pliers. Discard the component.

CAUTION: Application of too much solder can create solder bridges between PC patterns under the soldered component and around the pad.

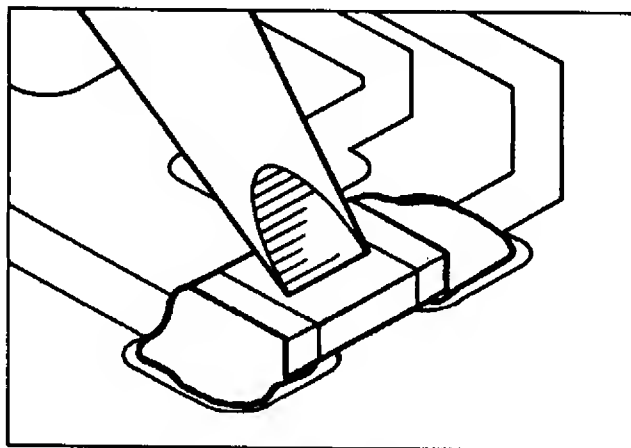

Figure 4 - 2

2. Completely remove old solder, old glue, and any other contaminants from the area with desoldering-wick and solvent.
3. Apply only enough fresh solder to coat the clean PC pad as shown in **Figure 4 - 3**.

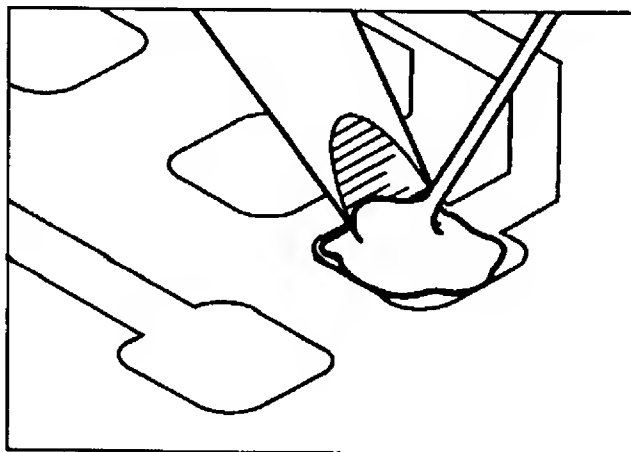

Figure 4 - 3

4. Place component and briefly heat the new solder and pad while holding the component with tweezers. Do not touch the new component with the iron. Only heated solder should touch the component to make a light "tack" bond to it. See Figure 4 - 4.

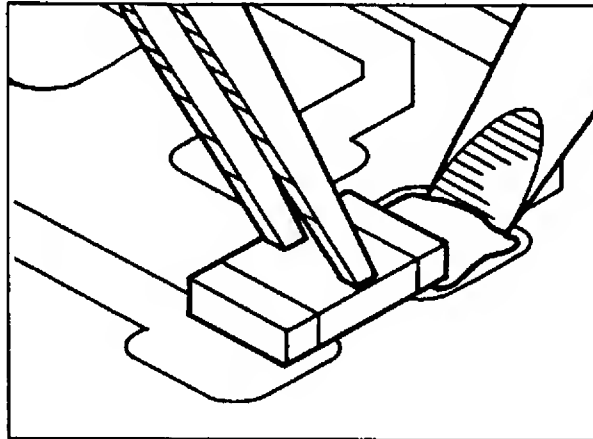

Figure 4 - 4

5. With one component end tacked to hold it, the other end can be soldered. Carefully apply heat to the PC pad while adding only enough fresh solder to produce a clean fillet as in Figure 4 - 5—do not apply too much solder, otherwise it may flow underneath and short the pads together. Let the hot solder flow onto the component—do not touch the component with the iron. Repeat to finish the other end of the component. Solder must adhere to all metallic end-surfaces on both ends as shown in Figure 4 - 6.

CAUTION: Avoid direct contact to the chip component with the iron tip. Too much heat and contamination will break down the metallic film on component ends resulting in loss of internal connection (a capacitor is comprised of several wafer plates that connect through the metallic end-surfaces). If satisfactory solder adhesion does not occur, the metallic end surface has been damaged and the chip component should be replaced again. More soldering will only damage the component further.

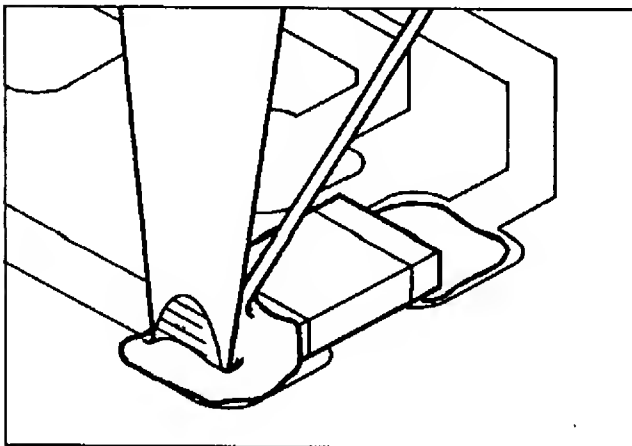

Figure 4 - 5

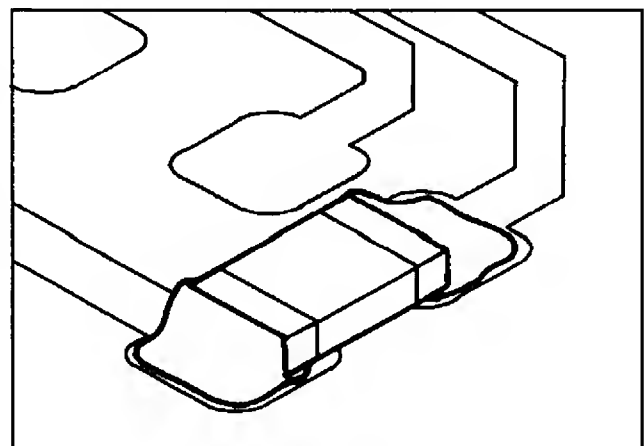

Figure 4 - 6

REPLACING COMPONENTS WITH FEED-THROUGH LEADS

Exercise extreme care when replacing components with leads that feed through a PC board. The copper plating on both sides of the printed circuit board and inside component lead holes easily separates and tears from the PC board when heated.

Use a solder suction tool or braided desoldering-wick to remove solder from component leads, one at a time. Solder must be removed carefully and thoroughly so that the IC can be pulled without resistance. After removing as much solder as possible, use a dental pick or straight-pin to break the leads loose from the inside of the cleaned-out hole. Cutting the defective components away from its leads first makes removing the leads and solder easier.

Before installing a new component, remove all solder from lead holes and make sure the device is oriented properly. Always inspect old part leads for any feed-through plating rings that may have been pulled out of holes. The plating may have completed a circuit. If so, make sure the corresponding lead of the new component is soldered to plating runners on both sides of PC board as shown below.

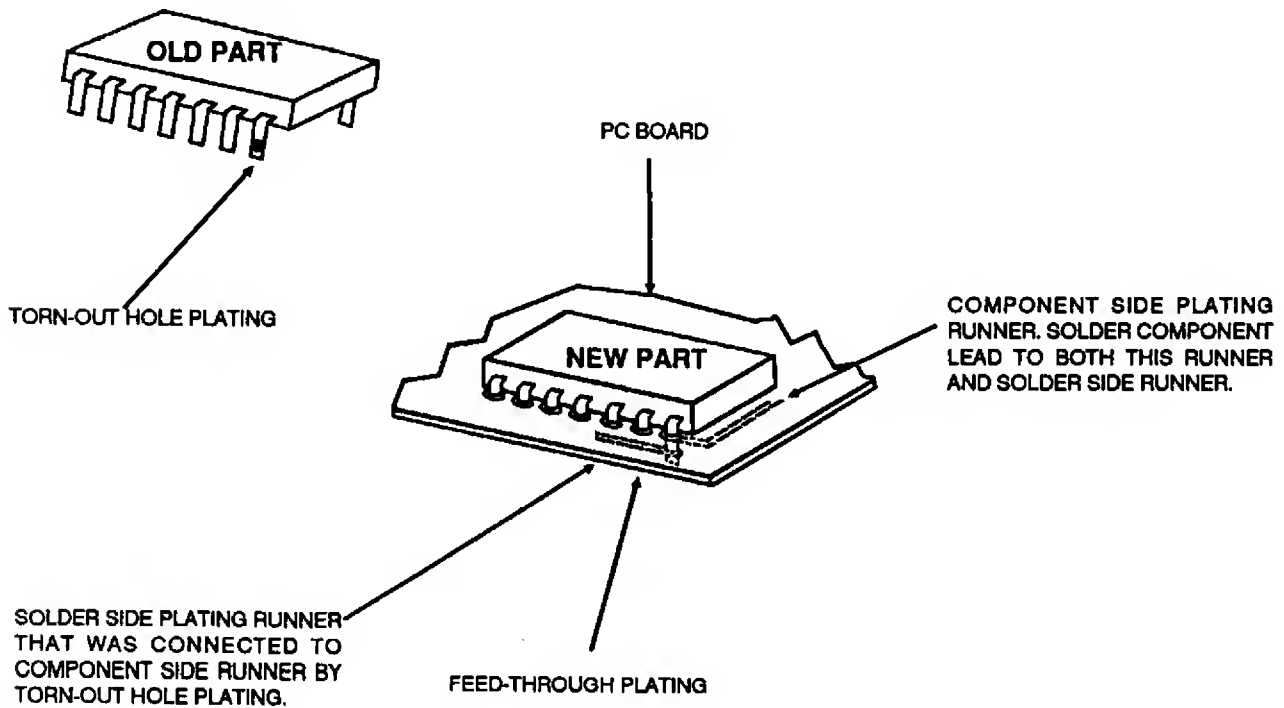

Figure 4 - 7

ELIMINATING RADIO INTERFERENCE

Occasionally, you must contend with interference from somewhere in the automobile. Interference problems are solved by understanding the interference and its path into the transceiver, locating its source logically, then eliminating it in the simplest way available.

Interference may be conducted into the transceiver directly, or induced into it, or both. Conducted interference passes through the DC power leads or the accessory wiring of the radio. Radiated interference, which can originate from anywhere in the vehicle, simply produces noise voltages on conductors inside the radio or its antenna. See **Figure 4 - 8**.

Conducted interference is simple noise voltage present in the vehicle electrical system. With many electrical devices turning on and off in a vehicle, current spikes produce voltage drops across wire resistances, causing voltage transients to appear throughout the electrical system. Connecting the radio power leads to this noisy electrical system applies the noise voltage directly to the radio. Most noise voltage is attenuated by power-line filters within the radio; but spikes that are severe enough may become audible.

While interference conducted through power leads affects only transceiver audio circuitry, induced interference often invades the receiver through the antenna by imitating receiver IF frequencies or channel frequencies. Induced interference occurs when an electromagnetic field penetrates the radio. If an electromagnetic field is strong enough, it can induce noise currents on the radio accessory and power wiring.

IDENTIFYING THE INTERFERENCE

The first step toward eliminating interference is to identify and characterize it. Listening to the noise can reveal a lot. For example: if the noise heard varies with engine speed, its source must relate to the engine, such as the alternator, ignition system, or tachometer.

Because you are dealing with frequency-modulated equipment, determining if the noise is at receiver-

sensitive frequencies is easy. With all squelch circuits open, simply apply an unmodulated signal to the transceiver that is strong enough (10 mV at the Antenna Jack) to overcome any high frequency noise signal that could invade below. If noise remains, interference is at low frequencies that can enter only by proximity coupling to radio wiring or direct conduction.

Next, power the radio with an independent 12 V power source (such as another car battery). Isolate by moving wiring and/or the radio while listening for changes in the noise level. If the noise stopped when you connected the independent power source, noise voltages are conducting through on the positive circuit or the ground (see **ELIMINATING CONDUCTED NOISE**).

ELIMINATING CONDUCTED NOISE

If noise voltage is present on the power leads, there may be defective equipment in the vehicle electrical system that needs repair. An alternator with a bad diode has a large current ripple on its output, which produces a whine in the transceiver that varies in pitch with engine speed. Its current capacity is limited, but vehicle operation will not be noticeably impaired. Lights that dim during large current demands are a good sign of such a defect.

Another possible source of conducted interference is a fan motor in the same circuit to which the radio is connected. Because a fan also induces interference, confirm that noise is conducted into the radio (see **IDENTIFYING THE INTERFERENCE**). If the interference is conducted into the DC power leads of the radio, find a power connection point in the electrical system for the transceiver that is further from the fan circuit.

Noise voltages can also be added to the radio DC power input via the ground path. This is a condition where a high, noisy current shares the ground path of the radio equipment. For example:

Ground current of a fan motor finds its way to the vehicle battery through segments of metal body A-frame assemblies (see **Figure 4 - 9**). If the elec-

ELECTROMAGNETIC RADIATION AT RECEIVER CHANNEL AND/OR I.F. FREQUENCIES

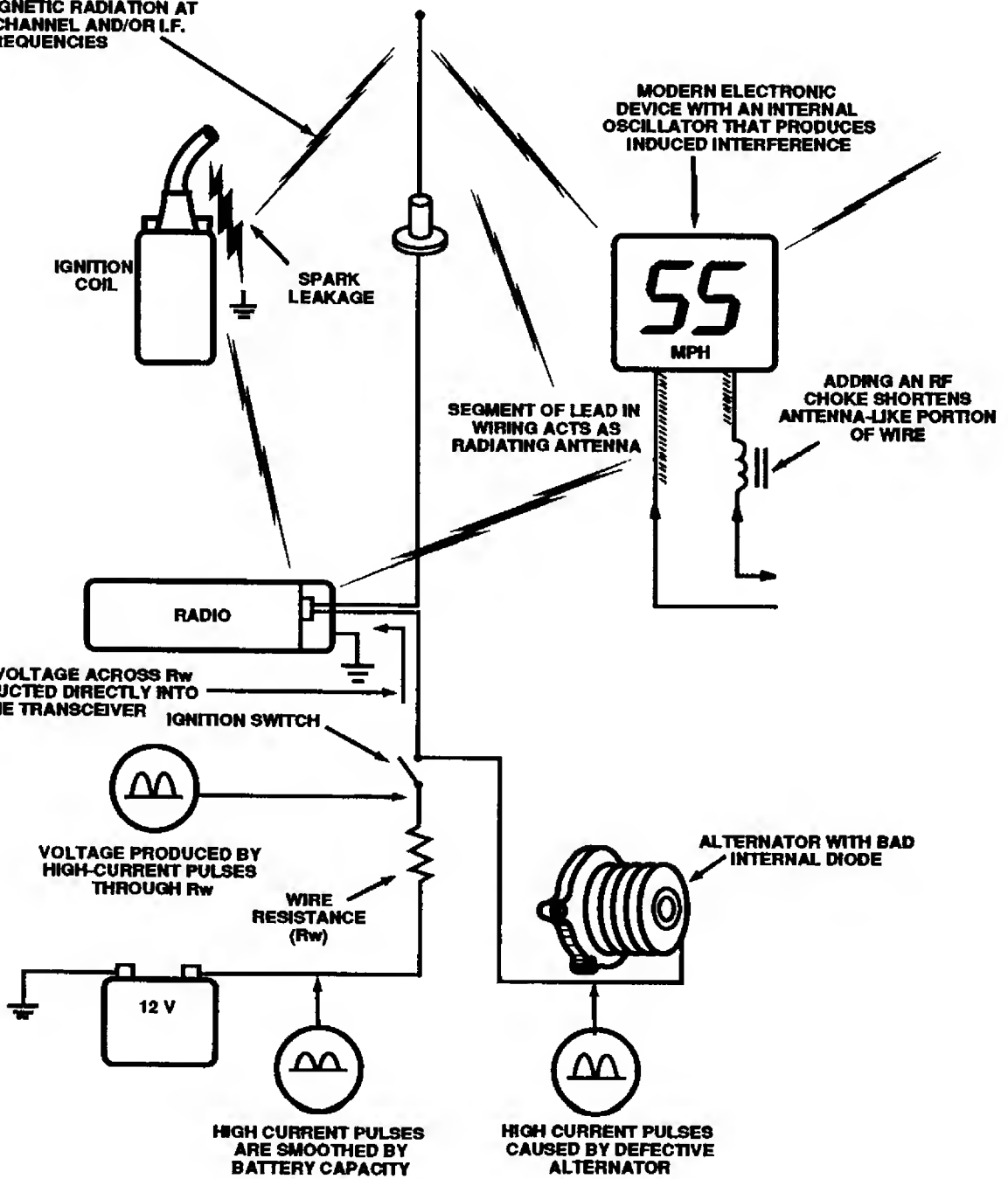

Figure 4 - 8 — Interference Paths

trical bond between two parts is weak, and the radio ground current must also travel through this weak joint, a voltage drop induced across the joint by the fan current will appear at the radio power plug.

To avoid a noisy ground, connect radio ground closer to the vehicle battery.

ELIMINATING RADIATED INTERFERENCE

If DC power source substitution proves interference is not conducted into the power leads, two likely sources of radiated interference are sparks and high frequency oscillators. Modern vehicles use many electronic accessories and systems that may produce a hash or whine in the transceiver. Oscillators within these devices, which sometimes are poorly shielded, may radiate an electromagnetic field at frequencies many multiples of the oscillator frequency.

Again, listen to the noise to learn about its source. Unless the interfering automobile accessory is part of engine operation, the noise won't vary with engine speed. The interfering accessory can be isolated by temporarily removing power to it and checking for absence of noise.

Because the lead-in wires of an automobile device can become radiating antennas, induced interference is more often radiated from the automobile accessory wiring than the accessory itself. Such interference can be inductively coupled into nearby radio power and accessory wiring or radiated toward the antenna.

Check that the radio wiring does not run next to, nor parallel with, vehicle wiring. Move the wiring to identify and/or solve this problem.

If necessary, RF chokes can be connected in series with the "hot" lead-in wires of the interfering device, close to its housing to kill the antenna effect. Usually, "hot" wires can be identified if the noise volume changes with wire movement.

Radiated interference may also enter through the antenna. This can be verified by substituting the antenna and its cable with a 50 Ω RF dummy load and short cable. The dummy load is necessary to

properly balance the receiver input and give comparable results. If the noise stops, interference was entering the antenna. The only way to solve this sort of interference problem is to eliminate radiation at the source with RF chokes as described above. Sometimes, positioning the antenna further from the interfering accessory may help.

ELIMINATING INTERFERENCE FROM SPARKS

Sparks produce electromagnetic energy over a large area of the RF spectrum. This energy usually invades the receiver input through the antenna. Therefore, the problem must be resolved at the source.

Modern vehicles use higher voltage ignition systems. As a result, electrical leakage occurs more easily through cracks and contaminants. If the interference produces a buzz while the engine is idling, and the buzz increases in pitch with engine speed, sparks are leaking to ground before distribution to the spark-plug wires. Check the Ignition coil, its high voltage wire, and distributor cap for signs of arcing through cracks and burns or over dirt.

If the interference produces a repetitive popping sound while the engine is idling, and it increases in rate with engine speed, a single spark plug or wire are suspect. Check the distributor cap, spark plug wires, and spark plugs for cracks, burns, and dirt.

Spark plug and ignition coil wires in modern vehicles are made with suppressive (resistive) conductors to reduce electromagnetic radiation. This may not be the case in older vehicles. Check with an ohmmeter.

Interference from sparks made by fan motor brushes produces a whine that varies with fan speed. Badly worn brushes or bearings cause excessive sparks, and you may need to replace them. A 0.1 μ F coaxial capacitor can be connected to the positive lead as close to the motor as practical to reduce radiated interference. The capacitor body must connect securely to the grounded motor housing.

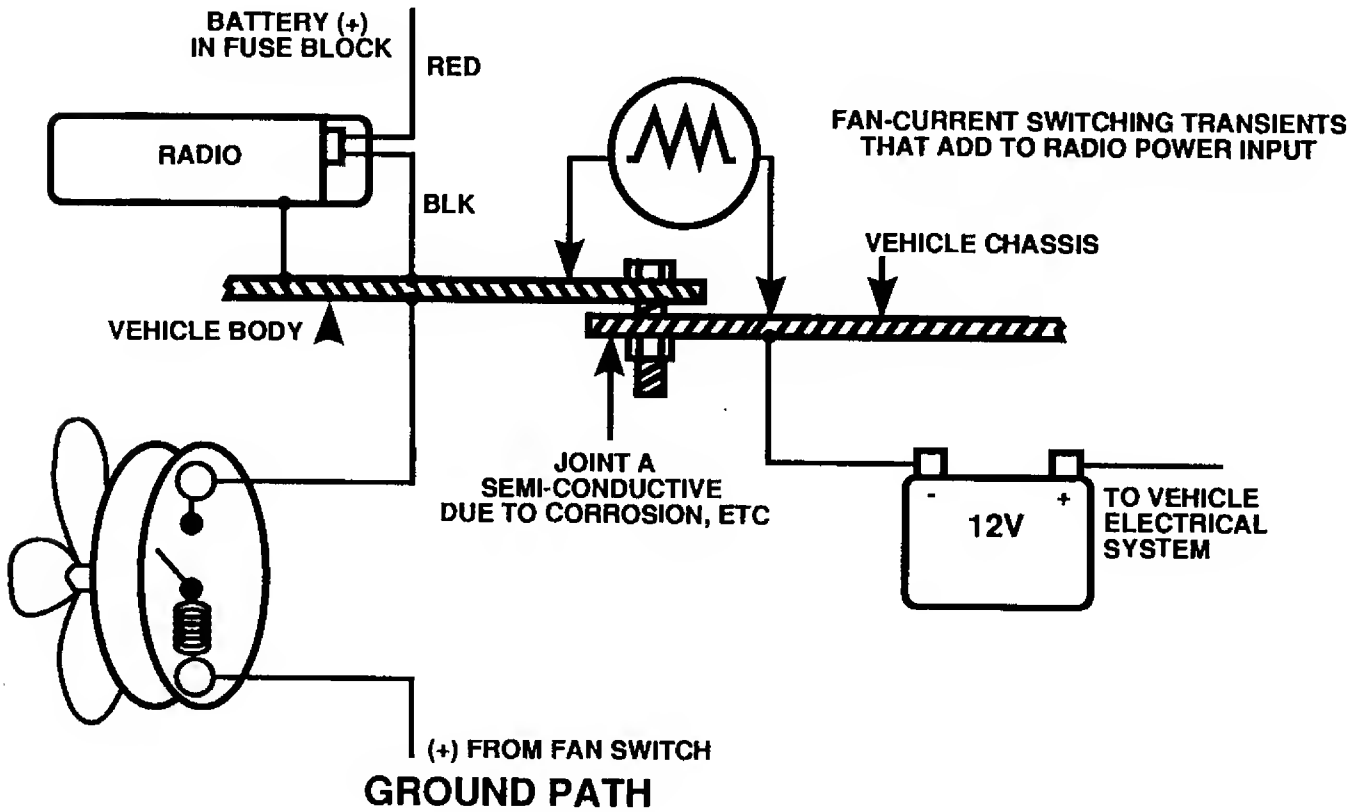

*THIS FAN MODEL EXCLUDES IT'S INDUCTANCE WHICH WOULD MAGNIFY THE ILLUSTRATED EFFECT

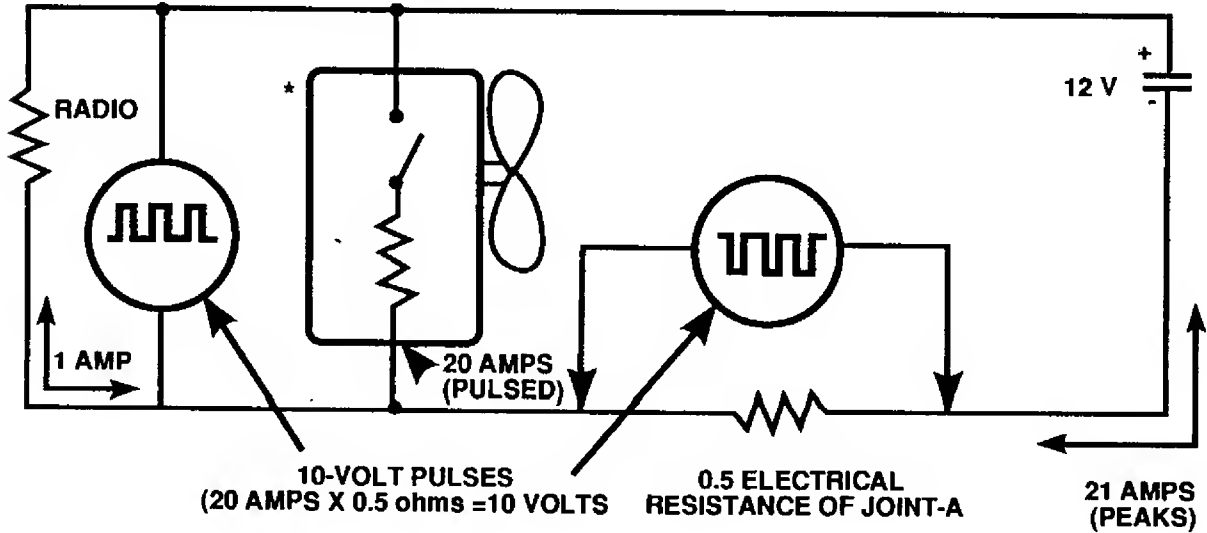

EQUIVALENT CIRCUIT

Figure 4 - 9 — A Noisy Ground

DC VOLTAGE CHARTS

Table 4 - 1 —Integrated Circuits, 13 to 16 Pins

NAME	MODE	PIN NO.							
		1	2	3	4	5	6	7	8
IC1	RX/TX	—	—	—	2.3	2.3	2.3	2.3	2.2
IC2	TX	—	—	—	—	5.0	0.0	0.0	2.3
	RX	—	—	—	—	0.0	5.0	0.0	2.3
IC50	RX/TX	1.7	1.7	1.7	5.0	1.7	1.7	1.7	1.7
IC241	SQ OPEN	6.7	6.6	6.6	6.8	6.4	6.4	6.4	6.8
	SQ CLOSED	6.7	6.0	6.6	6.8	6.4	6.4	6.4	6.8
IC301	RX/TX	0.0	—	5.0	—	—	—	—	—
IC302	RX/TX	—	—	—	—	—	—	—	0.0
IC404	RX/TX	4.7	8.5	9.1	0.0	0.1	4.8	0.0	0.0
IC411	RX/TX	4.7	4.7	4.7	9.0	4.7	4.7	4.7	4.7
IC771	RX/TX	2.3	2.3	4.7	4.7	4.6	0.0	4.7	3.2
IC772	RX/TX	0.7	0.7	0.7	0.7	9.0	9.0	0.0	0.7

NAME	MODE	PIN NO.							
		9	10	11	12	13	14	15	16
IC1	RX/TX	—	0.0	—	0.0	2.3	—	—	—
IC2	TX	2.3	2.3	2.3	5.0	0.0	5.0	—	—
	RX	2.3	2.3	2.3	0.0	5.0	5.0	—	—
IC50	RX/TX	1.7	1.7	0.0	1.7	1.7	—	—	—
IC241	SQ OPEN	2.8	0.7	0.8	3.0	0.0	3.0	0.0	1.8
	SQ CLOSED	2.8	0.7	0.8	3.1	6.3	4.7	0.0	1.8
IC301	RX/TX	—	—	—	—	—	—	—	—
IC302	RX/TX	—	—	—	—	—	—	—	5.0
IC404	RX/RX	8.5	9.1	0.0	0.2	0.0	9.0	—	—
IC411	RX/TX	4.7	4.7	0.0	4.7	4.7	4.7	—	—
IC771	RX/TX	0.0	4.8	0.1	—	—	—	4.6	3.5
IC772	RX/TX	0.7	0.7	0.7	9.0	9.0	9.1	—	—

4

Table 4 - 2 — Transistor Packs

NAME	MODE	PIN NO.					
		1	2	3	4	5	6
Q302	RX	0.0	5.0	0.0	0.0	5.0	0.0
Q303	RX	0.0	5.0	0.0	0.0	5.0	0.0
Q401	RX/TX	0.1	0.7	7.6	0.0	0.0	0.0
Q403	RX/TX	13.1	9.1	6.4	0.0	0—5.0	0.0—4.3
Q702	RX	7.6	0.0	0.0	0.0	0.0	8.2
	TX	7.6	0.0	7.5	7.5	8.0	8.2
Q703	RX	0.0	0.0	0.0	9.0	4.6	0.0
	TX	2.9	2.9	0.0	0.0	0.2	0.0
Q771	RX/TX	4.6	4.6	4.6	4.6	4.6	0.0
Q772	RX/TX	0.0	4.6	4.4	9.0	4.6	0.0
Q778	RX/TX	4.6	4.6	0.0	0.0	0.0	0.0

Table 4 - 3 — FET's

NAME	MODE	GATE 1	GATE 2	DRAIN	SOURCE
Q242	RX	0.0	—	9.0	0.52
Q408	SQ OPEN	4.7	—	5.0	5.0
	SQ CLOSED	0.0	—	5.0	5.0
Q711	RX	3.4	4.7	7.8	3.0
Q731	TX	3.4	4.7	7.8	3.0
Q801	RX	3.7	—	3.7	3.7
Q802	RX	3.7	—	3.7	3.7
Q803	RX	3.7	6.7	8.9	3.5

Table 4 - 4 — Integrated Circuits, 8 Pins or Less

NAME	MODE	PIN NO.							
		1	2	3	4	5	6	7	8
IC401	RX/TX	13.5	0.0	9.1	—	—	—	—	—
IC402	RX/TX	13.5	0.0	5.0	—	—	—	—	—
IC405	RX/TX	0.9	2.8	2.8	0.0	4.1	4.1	3.3	9.0
IC406	RX	6.5	6.5	6.4	0.0	6.0	13.5	6.5	—
IC408	TX	4.0	0.0	8.3	0.0	1.3	9.1	3.6	—
IC409	RX	4.0	0.0	0.0	0.0	1.3	9.1	3.6	—
IC412	TX	2.3	0.0	2.5	5.0	—	—	—	—
IC801	RX	8.9	8.9	0.0	2.83	4.5	2.8	0.0	8.9
IC9J2	RX/TX	4.9	4.9	0.0	—	—	—	—	—
IC903	RX/TX	0.0	0.0	0.0	8.2	—	1.2	9.1	3.6

Table 4 - 5 — Transistors

NAME	MODE	BASE	COLLECTOR	EMITTER
Q1	RX TX	0.7 0.0	0.0 5.0	0.0 0.0
Q2	RX	0.0-0.7	0.0-5.0	0.0
Q101	RX/TX	3.1	4.8	2.6
Q102	RX/TX	3.2	4.7	2.6
Q103	RX/TX	2.1	4.6	1.4
Q131	TX	0.9	7.6	0.7
Q201	RX	1.0	8.5	0.3
Q203	RX	0.7	6.2	0.5
Q241	RX	3.3	7.8	2.6
Q243	RX	3.1	9.1	2.2
Q244	RX	2.4	4.0	1.8
Q301	RX/TX	4.4	3.4	5.0
Q406	RX	3.6	5.0	3.0
Q409	RX/TX	8.8	8.8	8.2
Q410	RX	5.0	5.0	1.0
Q501	TX	0.5	0.0—12.2	0.0
Q502	TX	0.1	12.6	0.0
Q503	TX	0.0	12.6	0.0
Q504	TX	12.5	5.4	13.6
Q505	TX	0.0	12.6	0.0
Q507	TX	0.0	12.6	0.0
Q509	TX	0.7	0.6	0.0
Q701	RX/TX	9.0	9.1	8.2
Q704	TX	8.3	8.2	9.0
Q705	RX TX	4.2 0.2	0.3 8.0	0.0 0.0
Q712	RX	1.6	7.0	0.9
Q732	TX	1.0	7.6	0.4
Q733	RX/TX	1.8	8.3	1.3
Q734	TX	1.8	8.2	1.3
Q773	RX/TX	0.0	—	0.0
Q774	RX/TX	9.0	—	9.0
Q775	RX/TX	9.0	9.0	9.0
Q776	RX/TX	0.0	0.0	0.0
Q804	RX	0.7	0.3	0.1
Q805	RX	4.7	0.1	5.3
Q806	RX	8.6	0.1	5.3
Q807	RX	0.0	8.6	0.0
Q808	RX	8.6	0.0	8.1
Q809	RX	8.4	8.4	8.9
Q810	RX	8.4	5.4	8.9
Q811	RX	5.4	8.9	4.7

SERVICING

70-0371/0375

NOTES

SECTION 5

CIRCUIT DESCRIPTIONS

CIRCUIT DESCRIPTIONS

70-0371/0375

NOTES

The SYN-TECH XTR TX/RX unit is made up of three major sections: the RF Section, the PA Section, and the Logic Section.

RF SECTION

The RF Section consists of a frequency synthesizer, a transmit modulator, a receiver, and receive audio amplifier circuits.

SYNTHESIZER

Radio frequency signals for transmission and receiver injection are produced by voltage controlled oscillators (VCO's) in a phase-lock loop (PLL) configuration.

• Voltage Controlled Oscillator

In this radio, two VCO's are used — Q731 operates in transmit mode to generate transmit frequencies; Q711 operates in receive mode to generate receive injection frequencies. Each is buffered independently: by Q732 and Q712 respectively. Outputs of the buffers are amplified by Q131 and Q203 respectively. RF signal at receiver injection frequency ($F_c + 10.7$ MHz) is applied from the LO amplifier Q203 in the receiver circuit. RF signal from Q131 is amplified further by the PA portion.

When the frequency of the VCO output drifts away from the desired value, the loop adjusts the steering voltage to compensate. A single VCO tank is voltage-tuned by varactor diodes D711 and D731 respectively. Loop steering voltage applies reverse bias to all these varactor diodes simultaneously. As steering voltage increases, varactor diode capacitance decreases: thus, net capacitance in each tank decreases, which increases resonant frequency of the tanks.

• Loop Dividers

The amplitude of the VCO signal from Q734 collector for TX and Q733 collector for RX is sufficient to feed prescaling frequency divider involved in IC771, which applies an output pulse to once every 64 or 65 input cycles. Additional frequency division is also performed within IC771 to produce 2.5 kHz.

X101 is a temperature-compensated crystal oscillator that produces a reference frequency of exactly 12.8 MHz. The reference frequency is divided by

IC771 to produce 2.5 kHz that is compared to the down-counted 2.5 kHz sample of VCO output. Normally the loop response is slowed enough by a Lag-Lead filter to block 2.5 kHz reference noise and prevent loop correction of voice modulation during transmit. Higher active filter rolloff frequency is selected by the microcomputer system on the Logic portion when the radio changes channels or it is keyed and unkeyed, by a logic low applied to the base of Q772. This increase in loop response speeds locking time.

A connection from an intermediate point in the phase/frequency comparator in IC771 is made at pin 7. When the loop is out of lock, the down-counted VCO sample is not in phase with the 2.5 kHz reference and low going pulses appear here, which produce a logic low at pin 7. This logic low is applied to Q778 through Q771 to switch Q403-1/2 and Q504. Q504 then clamps off bias to transmit PA preamplifier Q501 to prevent emission of erratic signals generated by the uncontrolled VCO.

• Modulator

Voice signals from the hand-microphone are applied to the active filter IC411, where frequency response is pre-emphasized and splatter filtered. Gain is such that stronger signals bring the output into clipping, which limits modulation. Harmonics above the 3 kHz modulation pass-band are removed by the 2.5 kHz pi-network in IC411. Modulation signals are then adjusted by IC408 and IC404 so that modulation at limiting will produce transmitted carrier deviation of ± 5 kHz. Output of processed voice signals at IC411 pin 14 is fed to the gain control IC408, where the control voltage is fed from the D/A converter IC404, controlled by the programmer.

RECEIVER

• Preselector

Through the TX and RX relay, RF signals are routed to the receiver input. Signals at image frequencies

CIRCUIT DESCRIPTIONS

70-0371/0375

and frequencies far removed from the desired channel are rejected by a preselector comprised of eight top-coupled, parallel tanks: L201, L202, L203, L204, L205, L206, L207 and L208. No tuning of these tanks is required for the entire channel frequency spread (6.3 MHz for A Band, 6 MHz for B Band, and 8 MHz for C Band). Q201 provides adequate gain to overcome preselector signal losses and maximize receiver sensitivity.

• Injection

First Local Oscillator signal ($F_c + 10.7$ MHz) is synthesized by the phase-lock loop and applied to Q203. A low-pass filter is provided at the output of Q203, and this rejects extraneous synthesized signals.

• First Mixer

To maximize intermodulation immunity, a balanced configuration is used for the first-mixer stage. High Injection is applied to L212-primary and preselector output is applied to its secondary center tap. Diode double balanced mixer using quad-diode D202 is employed. High injection is applied to the push-pull input of the mixer. Some of this signal appears at mixer output, but most is lost because L211 is designed to be operated at the 10.7 MHz First IF frequency.

• First IF

Mixer output is applied to Q241, which drives L245. L245 tunes to match the input impedance of 10.7 MHz crystal filter FL241 and FL242, which reject signals outside the channel bandwidth. L247 matches FL242 to Q242 where the First IF signal is amplified at least 20 dB, then applied to Second IF IC241.

• Second IF

IC241 contains all second IF circuitry, a quadrature demodulator, and threshold gate. X241 and circuitry in IC241 generates a second LO injection of 10.245 MHz. A double-balanced mixer, that cancels both input signals internally, is used so that additional tuned circuits at its output are not needed. Mixer output signal of 455 kHz (IC241 pin 3) is bandpass filtered further by FL243 and FL244, then superamplified (100+ dB) by the second IF amplifier/limiter within IC241 (at pin 5).

• Demodulation

The quadrature detector in IC241 is another double-balanced mixer to which limiter output is applied. Its second input is taken from 455 kHz tank L250. Limiter output (IC241 pin 7) is also fed to L250. Frequency deviations from carrier center will cause phase difference between the two demodulator inputs, which produces output. Thus preamplified recovered audio appears at demodulator output pin 9. C264, C265 and L251 attenuate signals above 100 kHz.

• Audio

Recovered audio from Q243 is routed to the gain control IC409 and applied to the active filter IC411. The amplification level is controlled by the gain control unit. Output of the gain controller IC409 is applied to the audio amplifier IC406. Power Amplifier IC406 amplifies the audio signal and drives the speaker.

• Squelch

Audio signals at low-pass filter L251 are routed through Squelch Range RV241, which calibrates squelch-break level when the front panel SQUELCH control is maximum. Signals at RV241 top feed a two-tank 50 kHz filter. The resulting 50 kHz signal is amplified by IC241 and Q244, then rectified by D243 to produce a DC voltage that varies inversely with received RF-carrier level. The front panel Squelch control sinks current from D243 so that the voltage can be adjusted. The DC voltage is input to a level detector within IC241 and detector output is an open collector that sinks voltages to logic low when on-channel receiver input is above the squelch threshold established by RV241. Level detector output is applied through NSQ, the interconnect to microcomputer input port P41, so that the microcomputer can take appropriate action.

• Noise Blanker

Noise generated at the output of Q241 is amplified at Q803 and then sent to IC801. IC801 controls gain of pin 8 output through Q809—Q811 (rectifier/amplifier circuit). The signal is fed back to pin 5. Output of IC801 pin 1 is rectified at Q804 and sent to Q805 and Q806 (one-shot multi-vibrator), which generates a blanking pulse. This pulse is amplified at Q807 and Q808, causing Q801 and Q802 to switch IF signal on and off.

110-WATT PA SECTION

• RF Power Amplifier

A PC-board stripline is used to match the Q501 base terminal to the coax. RF impedance at the collector of Q501 is transformed by PC-board stripline to the base terminal of drive Q502 and the collector of Q502 is transformed to the base of Q503. Transformer T1 splits driver output to feed twin finals Q505 and Q507. Final-stage outputs are combined by Transformer T2. In transmit mode, K501 connect this RF signal to the harmonic filter consisting of L512, L521 and L522 which purifies the signal before emission by the antenna connected to J502. R520 and R521 serve to drain static and other DC potentials from the antenna.

• Antenna Gate

In receive mode, Relay K501 is switched to the J502—J503 route. The RF signal path from final amplifier Q505 and Q507 is then severed.

In transmit mode, Relay K501 is switched off the C544 route. The receiver port network is detuned so that it appears as a high impedance to the

antenna, and K501 switches final amplifier output to the antenna at J502.

• Automatic Power Control

T3, ahead of the harmonic filter, serves as a directional coupler. D502 rectifies a small RF sample that is developed across the thin runner, producing a DC voltage that increases with RF power traveling forward into the antenna. This power-level sensing voltage is the inverting input of the comparator IC405 pin 2. The reference voltage applied to the comparator IC405 pin 5 is fed from the D/A converter IC404 pin 4, which is controlled by the microcomputer via the programmer (in alignment mode).

Output of the comparator IC405 is applied to Q504 via Q404, which is a current source that feeds primary DC, to the collector circuits of the predriver Q501. The feedback loop, from the directional coupler to Q504 via the comparator input IC405 pin 6 holds RF output power at the constant level determined by the reference voltage of IC405 pin 5, which is initially adjusted using the programmer.

5

LOGIC SECTION

DC POWER AND RESET

5 V DC power to all logic circuitry in the Logic portion is supplied from switched 13.6 V and is regulated by IC402. Microcomputer IC901 is powered by the 5 V drop across D903, which is sourced by IC401 9 V regulator supply.

MICROCOMPUTER

Radio operation is under control of a microcomputer system located on the Logic Board. This system is comprised of Microcomputer IC901 and 2K EEPROM IC903.

All CPU activity is performed step-by-step in time with a clock. The frequency of the clock is fixed by crystal X901. Because of the high clock speed, microcomputer activity seems instantaneous.

• Display and Switches

Rotating S305 (UP) or (DN) applies a momentary logic low to pin 56 or 55 of IC901, respectively. IC901 interprets this request as a channel change up or down and outputs the appropriate BCD display data from pin 13—pin 16 (DSP3—DSP0), which is applied to the BCD-to-Seven Segment Display driver, IC301. The channel display data is latched into IC301 by the DSP STB from pin 12 of IC901. Once latched, the appropriate channel is displayed on the channel display, D301.

Pressing S301 (MON) applies a momentary logic low to pin 50 of IC901. IC901 responds by putting CTCSS/DCS decode (if installed) in the monitor state and outputs a logic high from pin 13 (DSP3) which is latched in IC302 by the LED STB sent from pin 11. The logic high is inverted by Q302-2/2 to light the MON LED, D303.

CIRCUIT DESCRIPTIONS

70-0371/0375

Pressing optional switch S302 (PSCAN) applies a momentary logic low to pin 51 of IC901. IC901 places the radio in the PSCAN mode and indicates this by outputting a logic high from pin 16 (DSP0) which is latched into IC302 by the LED STB sent from pin 11. The logic high is inverted by Q302-1/2 to light the optional PSCAN LED, D304.

Before going into the PSCAN mode, pressing S304 (ADD/DEL) applies a momentary logic low to pin 49 of IC901. IC901 outputs to the ADD/DEL LED (D306), causing it to begin flashing, allowing the user to check the PSCAN list.

During transmit, TX 9V is present at the anode of D701, which applies a positive voltage to the anode of the TX LED, turning it on. When a signal is received, Q410 is turned on, which allows a positive voltage to be applied to the anode of the BUSY LED via D401-3/3

• CTCSS/DCS Encode/Decode

IC901 controls CTCSS/DCS encode and decode. If the optional 70-2157 CTCSS board has been installed, during receive mode the receive audio signal is high-pass filtered at IC50 (on the 70-2157 board) to remove the CTCSS/DCS tones/codes. The CTCSS/DCS square wave is input through the Signal I/O line, pin 8 of IC901. IC901 determines if the CTCSS/DCS signal received is a valid tone/code. If it is valid, the output at pin 21 (MUTE) will go to logic high, which opens radio squelch.

In TX mode, pin 8 of IC901 will output the programmed CTCSS/DCS tone/code to the 70-2157 board, if installed. TXDL goes low, turning off Q1, which turns on IC2-2/4 and IC2-4/4, allowing the tone/code on the Signal I/O line to pass through IC1. IC1 is a programmable filter that "cleans up" CTCSS/DCS tones/codes. The generated tone is applied to Level Adjust RV1, and from there to Balance Control RV401 via C6. The signal is then sent to IC411-3/4, where it is mixed with the mic audio, and also to D102 in the reference oscillator.

• RX and TX Switching

In receive mode, TXDL (pin 33 of IC901) is at logic high. This turns Q705 on, which causes Q702-1/2 to turn on. This applies RX8V to the VCO. Also, when

TXDL is high, Q703-1/2 turns on, and Q703-2/2 turns off. This turns Q702-2/2 and Q704 off, which turns TX8V and TX9V off.

In transmit mode, TXDL is at logic low. This turns Q703-1/2 off, which turns Q703-2/2 on. This turns Q702-2/2 and Q704 on, which turn TX8V and TX9V on. Also, when TXDL is low, this turns Q705 off, which causes Q702-1/2 to turn off. This turns RX8V off, and TX8V and TX9V on.

• Data Control

When the radio is turned on, the contents of EEPROM IC903 are serially clocked into IC901 so that it can set up receiver frequency, scan operation, transmit/receive hold timer, busy-channel lock-out timer, time-out-timer and reference oscillator frequency control.

When a channel is changed, or when PTT is pressed, the contents of EEPROM IC903 are sent to IC901. IC901 then uses this data to send the appropriate information for the channel selected to IC771, CTCSS/DCS circuitry, display circuitry, and any signalling options.

• Reference Oscillator Frequency Control

The resistance of thermistor R107 varies with temperature. This resistance change is converted to a voltage by IC405. Output of IC405 is sent to IC901 pin 59 (TEMP). IC901 compares this data internally with the preset crystal type and programmed offset, and outputs a compensating voltage from pin 60 (F CONT). This voltage is sent to varactor diode D101 to stabilize the frequency of the reference oscillator.

• Transmit Output Power Control

Power level data is sent from IC901 pin 40 (DATA) to IC404 (the D/A converter) and outputs a reference voltage from pin 4 as described under "Automatic Power Control" on page 5 - 5.

• Modulation Level Control

Modulation level data is sent from IC901 pin 40 (DATA) to IC404 (the D/A converter) and outputs a reference voltage from pin 2, which adjust the gain of IC408. This controls the modulation level as described under "Modulator", page 5 - 3.

Table 5-1—IC901 PINOUTS

Pin No.	Pin Name	I/O Flow	Function Label	Logic & Function
1	P37	I	PC RTS	Programmer Interface
2	P36	O	PC CTS	Programmer Interface
3	P35	O	PC RD	Programmer Interface
4	P34	I	PC SD	Programmer Interface
5	P33	I	PC CD	Programmer Interface
6	P32	O	BEEP OUT	Beep Tone Output
7	P31	O	SGNCLK	Clock Output for CTCSS/CDCSS
8	P30	I/O	SG IO	Signal I/O for CTCSS/CDCSS
9	P57	O	LEDCHK	LED Check Output
10	P56	O	LEDAUX	not used
11	P55	O	LED STB	Paralleled-Data Strobe for Indicators
12	P54	O	DSP STB	Parallel Data Strobe for Displays
13	P53	O	DSP3	Display/LED Data
14	P52	O	DSP2	Display/LED Data
15	P51	O	DSP1	Display/LED Data
16	P50	O	DSP0	Display/LED Data
17	P67	O	AUXOUT	Aux Switch Output (Low = ON)
18	P66	I	TASW	Talk-around Switch Input (Low = ON)
19	P65	O	SCRB STB	Serial Data Strobe for Voice Scrambler
20	P64	O	AUX STB	Serial Data Strobe for AUX
21	P63	O	MUTE	Low = MUTE
22	P62	I	HANGUP	Low = HANG UP
23	P61	I	PTT	Low = TX
24	P60	I	VLINT	Low = LOW VOLTAGE
25	R/W	O	---	not used
26	SYNC.	O	---	not used
27	CNV _{SS}	I	---	GND
28	RESET	I	---	Low = MICROCOMPUTER RESET
29	X _{IN}	I	---	Crystal Oscillator, 8 MHZ
30	X _{OUT}	O	---	Crystal Oscillator, 8 MHZ
31	0	O	---	not used
32	V _{SS}	I	---	GND
33	P27	O	TXDL	Low = TX ACTIVATE
34	P26	O	DA STB	Serial Data Strobe for D/A Converter
35	P25	O	VCOSW	VCO Switch Signal Output
36	P24	O	LPSW	Loop Switch Signal Output
37	P23	I/O	PLCL	Synth Unlock (Low = UNLOCK)
38	P22	O	DSTB	Serial Data Strobe for Synthesizer
39	P21	O	DCLK	Clock for Serial Data
40	P20	O	CHDT	Serial Data Output
41	P17	I/O	---	not used
42	P16	I/O	ECS4	Chip Select for EEPROM 4
43	P15	I/O	ECS3	Chip Select for EEPROM 3
44	P14	I/O	ECS2	Chip Select for EEPROM 2
45	P13	I/O	ESC1	Chip Select for EEPROM 1
46	P12	O	ECLK	Clock for EEPROM
47	P11	O	EDI	Data Input into EEPROM
48	P10	I	ED0	Data Output from EEPROM
49	P07	I	AUXSW/CH0	AUX Switch (Low = ACTIVE)/CHNL NO. INPUT
50	P06	I	MONSW/CH1	Monitor Switch (Low = ACTIVE)/CHNL NO. INPUT
51	P05	I	PRI SW/CH2	PRI Switch (Low = ACTIVE)/CHNL NO. INPUT
52	P04	I	SCNSW/CH3	SCAN Switch (Low = ACTIVE)/CHNL NO. INPUT
53	P03	I	DEPWRSW/CH4	DE-POWER Switch (Low = ACTIVE)/CHNL NO. INPUT
54	P02	I	---/CH5	not used/CHNL NO. INPUT
55	P01	I	DNSW/CH6	DOWN Switch (Low = ACTIVE)/CHNL NO. INPUT
56	P00	I	UPSW/CH7	UP Switch (Low = ACTIVE)/CHNL NO. INPUT
57	P42	I	VL TIN	not used
58	P41	I	NSQIN	NSQ Status Input (High = RECEIVE)
59	P40	I	TMPTR	Thermal Sensor Input
60	DA2	O	REFCNT	Reference Frequency Control Output
61	CA1	O	---	not used
62	VREF	I	---	Reference Voltage Input to Convert A/D
63	AVSS	I	---	GND
64	VCC	I	---	+5 V

5

CIRCUIT DESCRIPTIONS

70-0371/0375

NOTES

SECTION 6

DIAGRAMS

DIAGRAMS

70-0371/0375

NOTES

A B C D E F G H I J K L M N

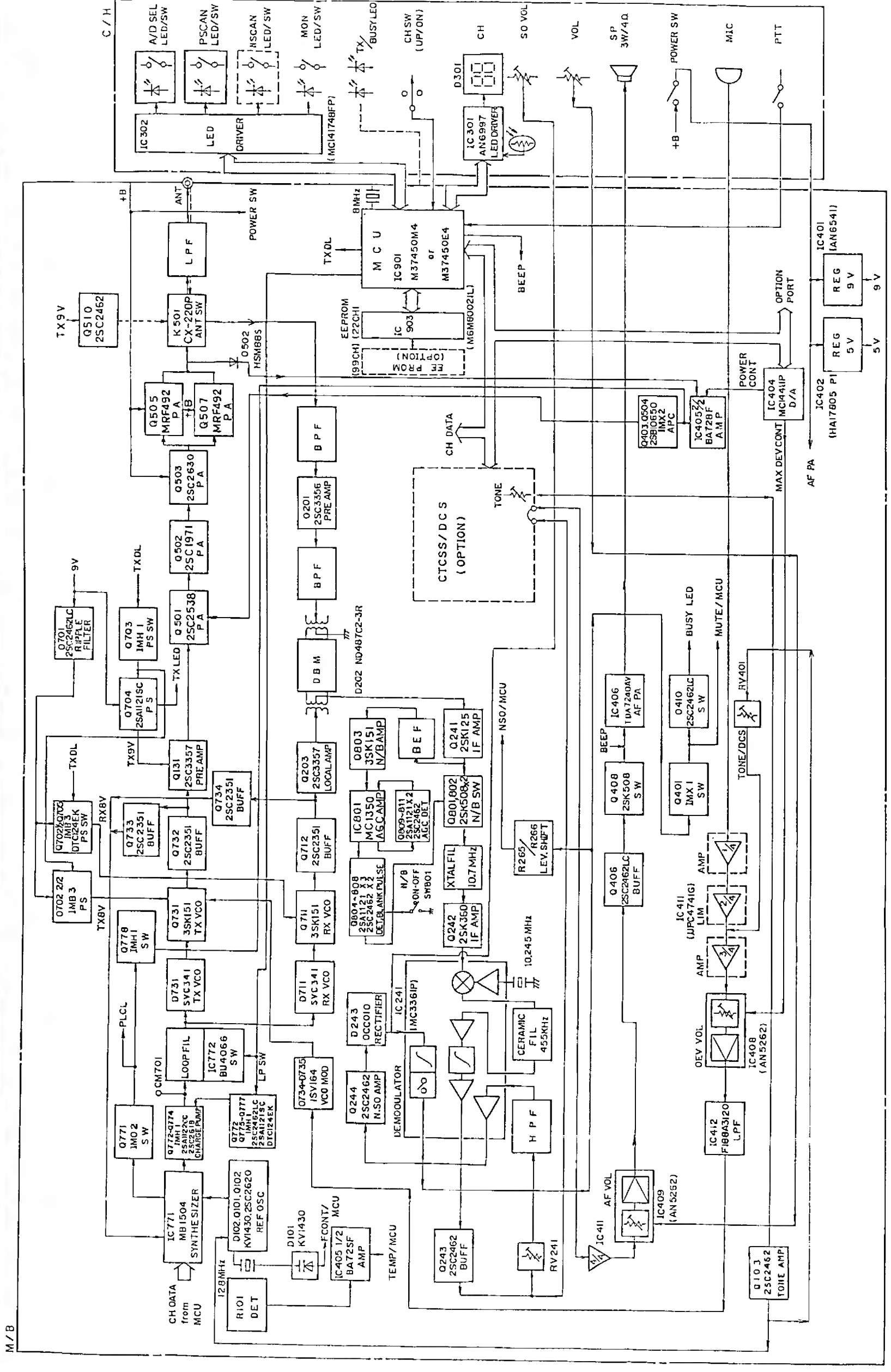

OPTION

UNDER-DASH WIRING DIAGRAM

70-0371/0375

A B C D E F G H I J K L M N

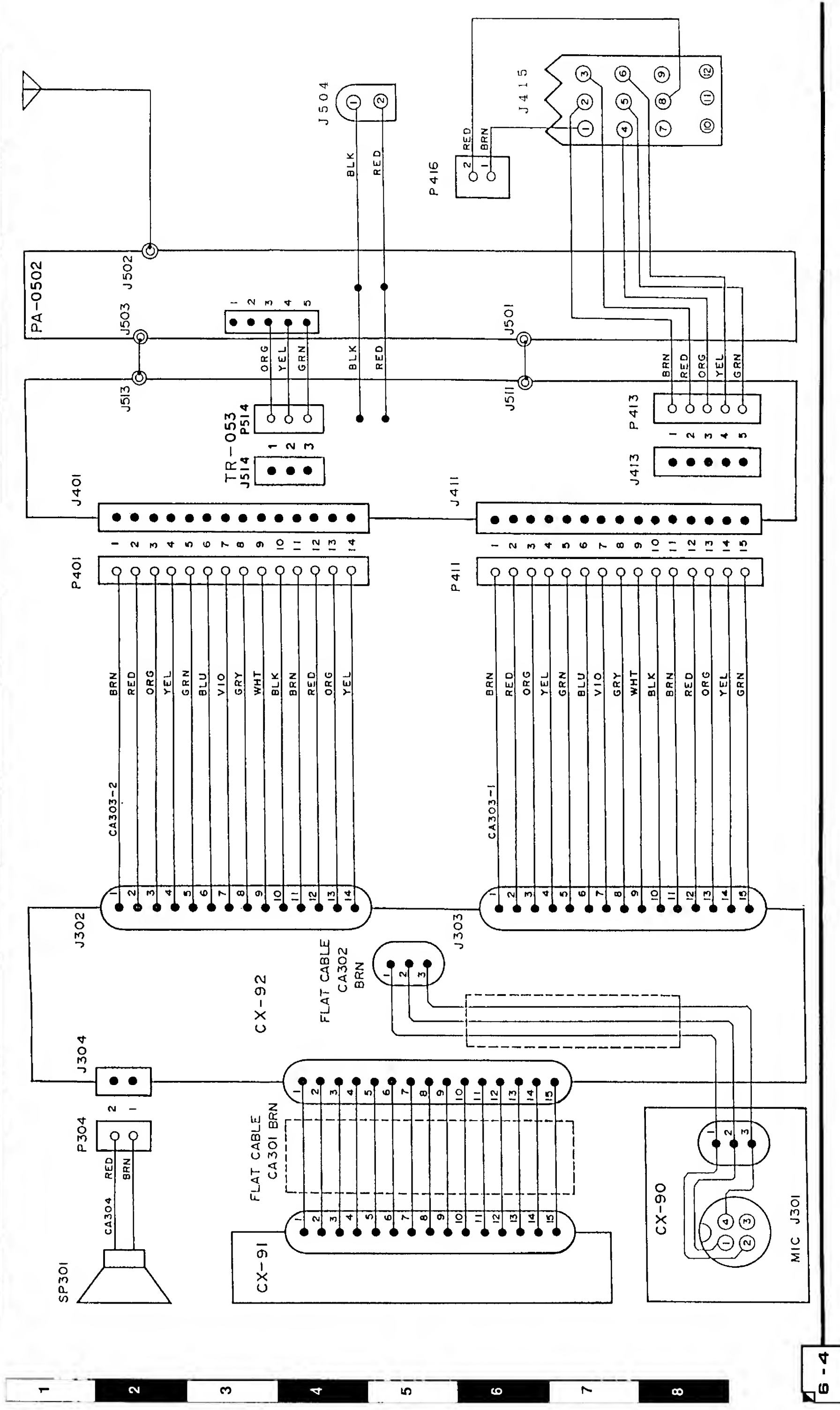

TRUNK-MOUNT WIRING DIAGRAM

70-0371/0375

A B C D E F G H I J K L M N

1 2 3 4 5 6 7 8

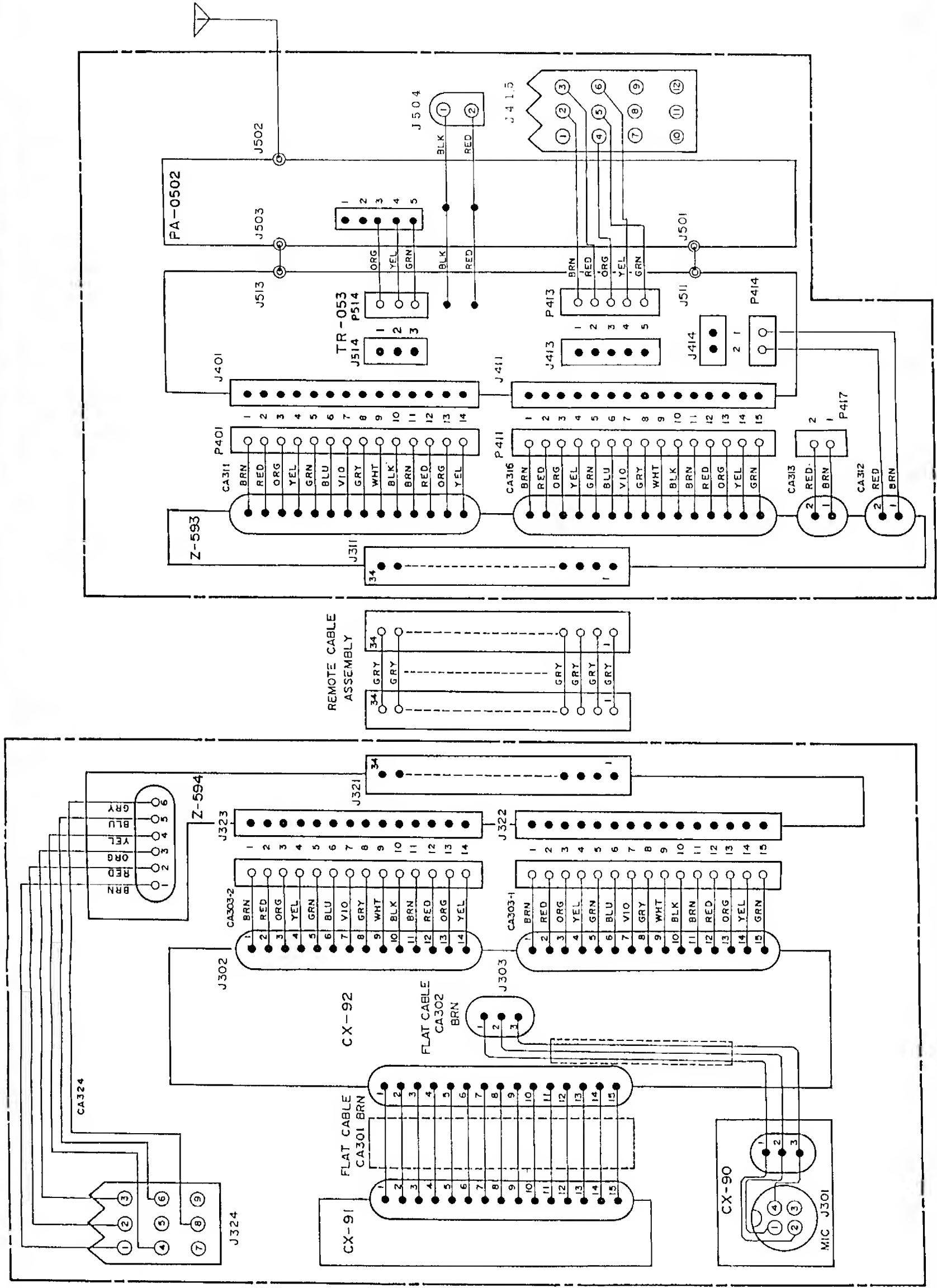

CX - 90 LAYOUT
TOP VIEW

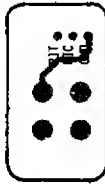

1

2

3

4

CX-90 LAYOUT
BOTTOM VIEW

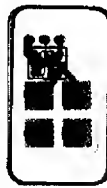

5

6

CX-91 LAYOUT TOP VIEW

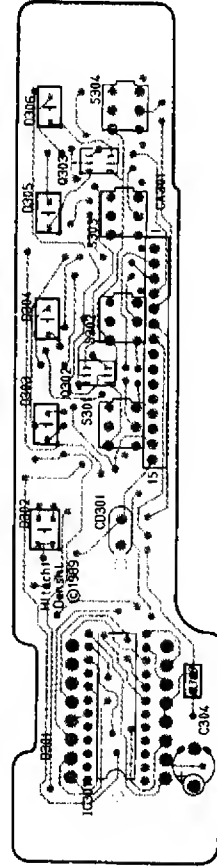
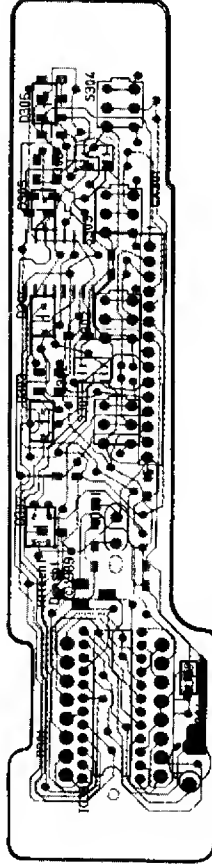

CX-91 LAYOUT BOTTOM VIEW

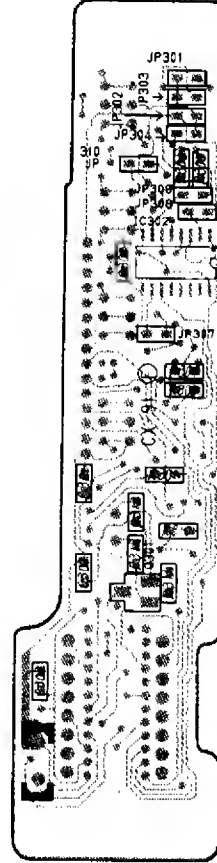
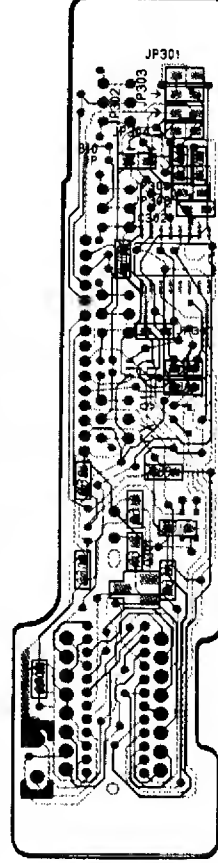

7

8

CX-92 LAYOUT TOP VIEW

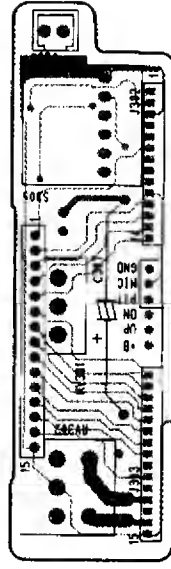
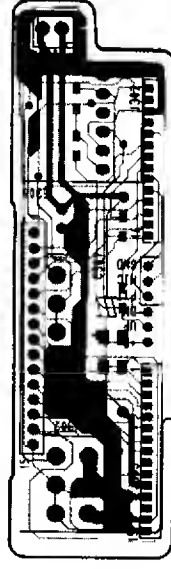

CX-92 LAYOUT BOTTOM VIEW

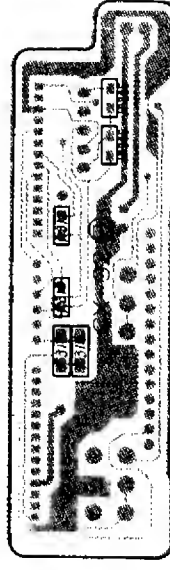
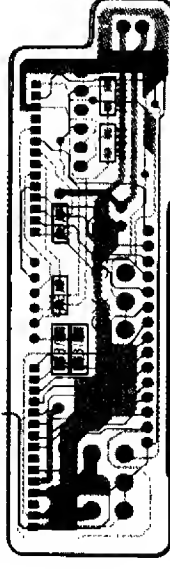

UNDER-DASH CONTROL HEAD SCHEMATIC

70-0371/0375

A

B

C

D

E

F

G

H

I

J

K

L

M

N

1

2

3

4

5

6

7

8

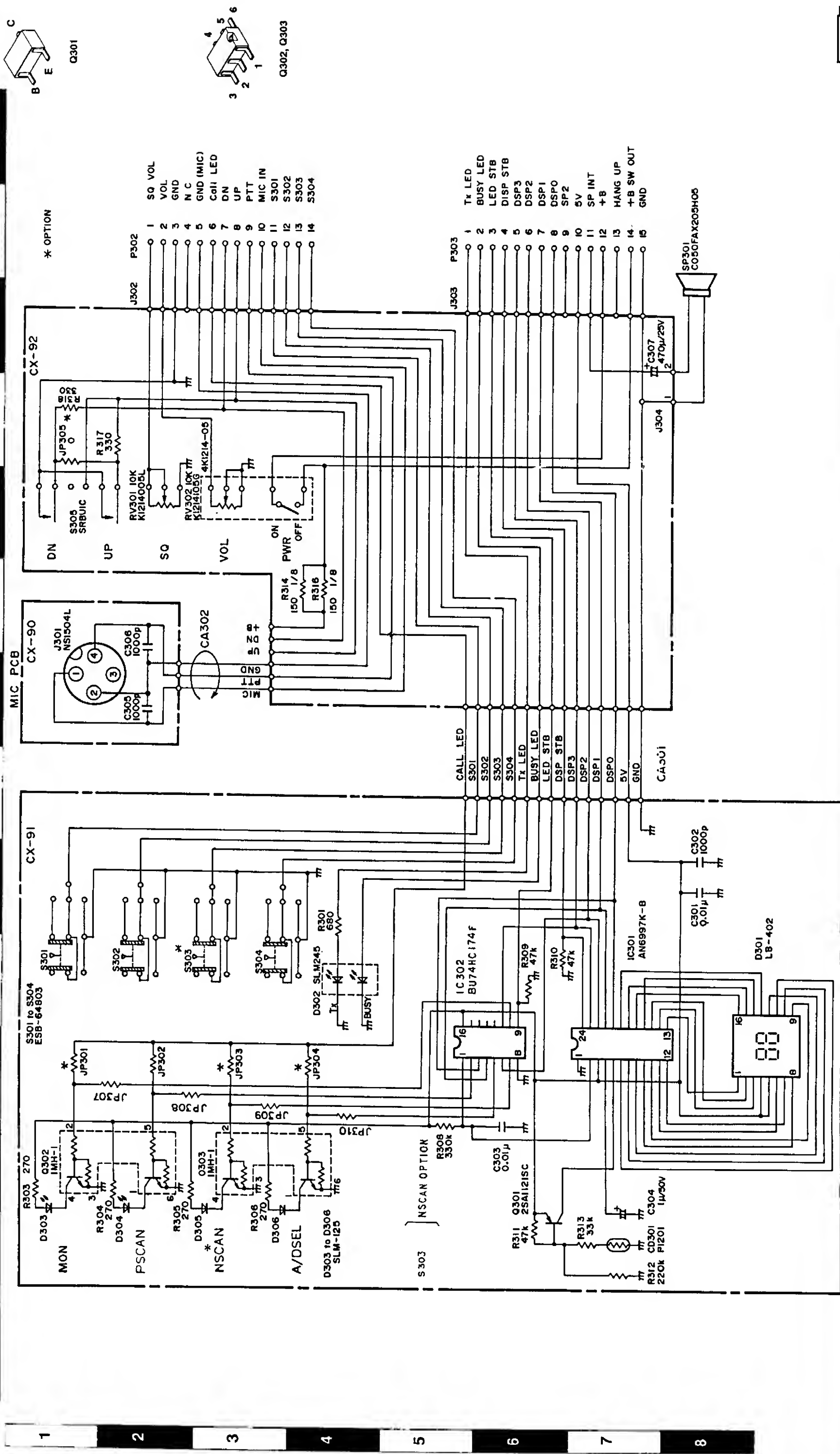

TRUNK-MOUNT CONTROL HEAD SCHEMATIC

70-0371/0375

A B C D E F G H I J K L M N

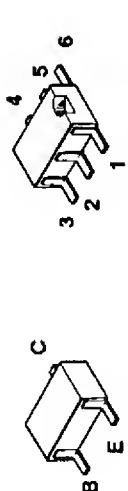
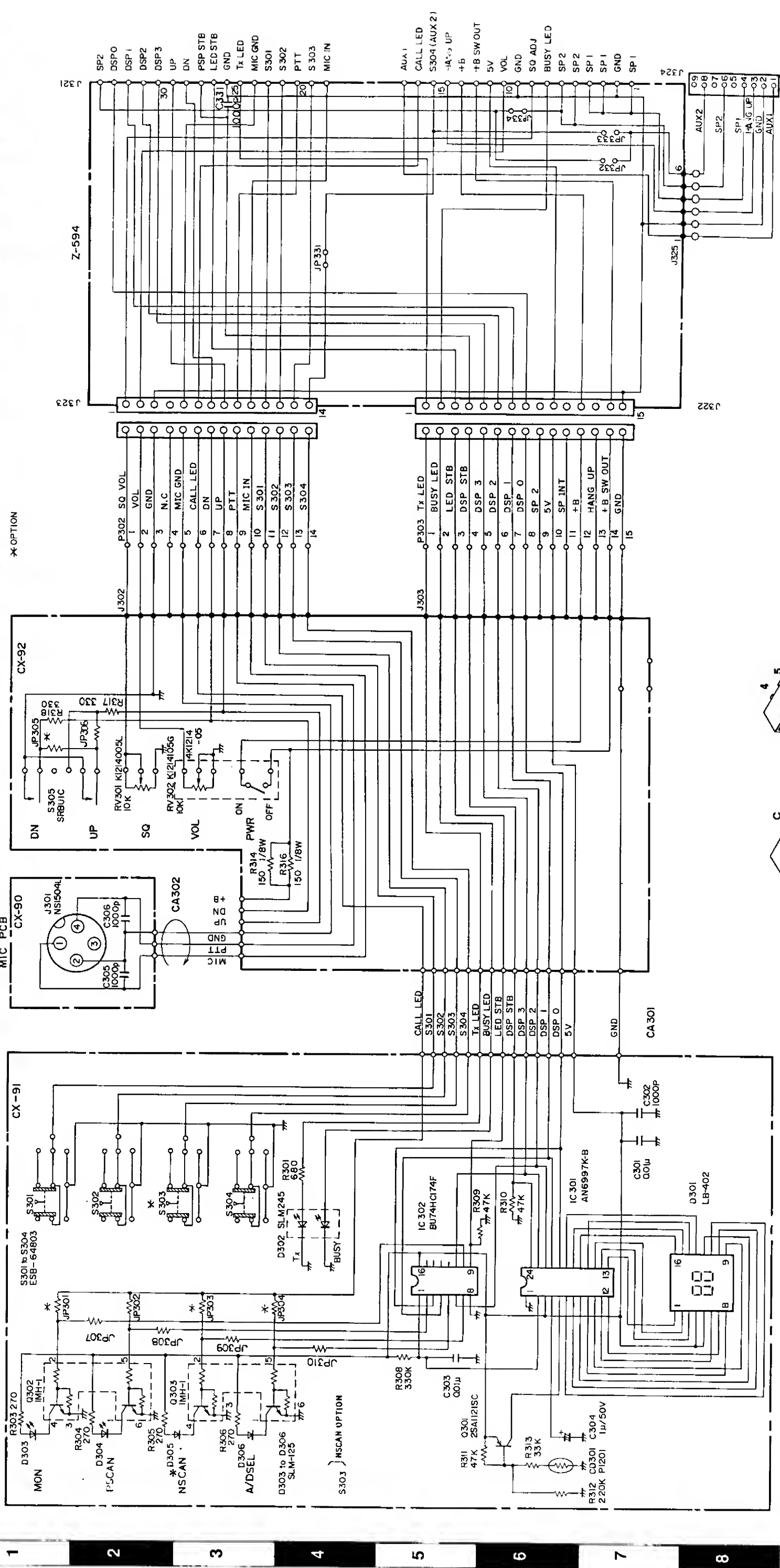

TR-053 LAYOUT--BOTTOM VIEW

70-0371/0375

A B C D E F G H I J K L M N

1 2 3 4 5 6 7 8

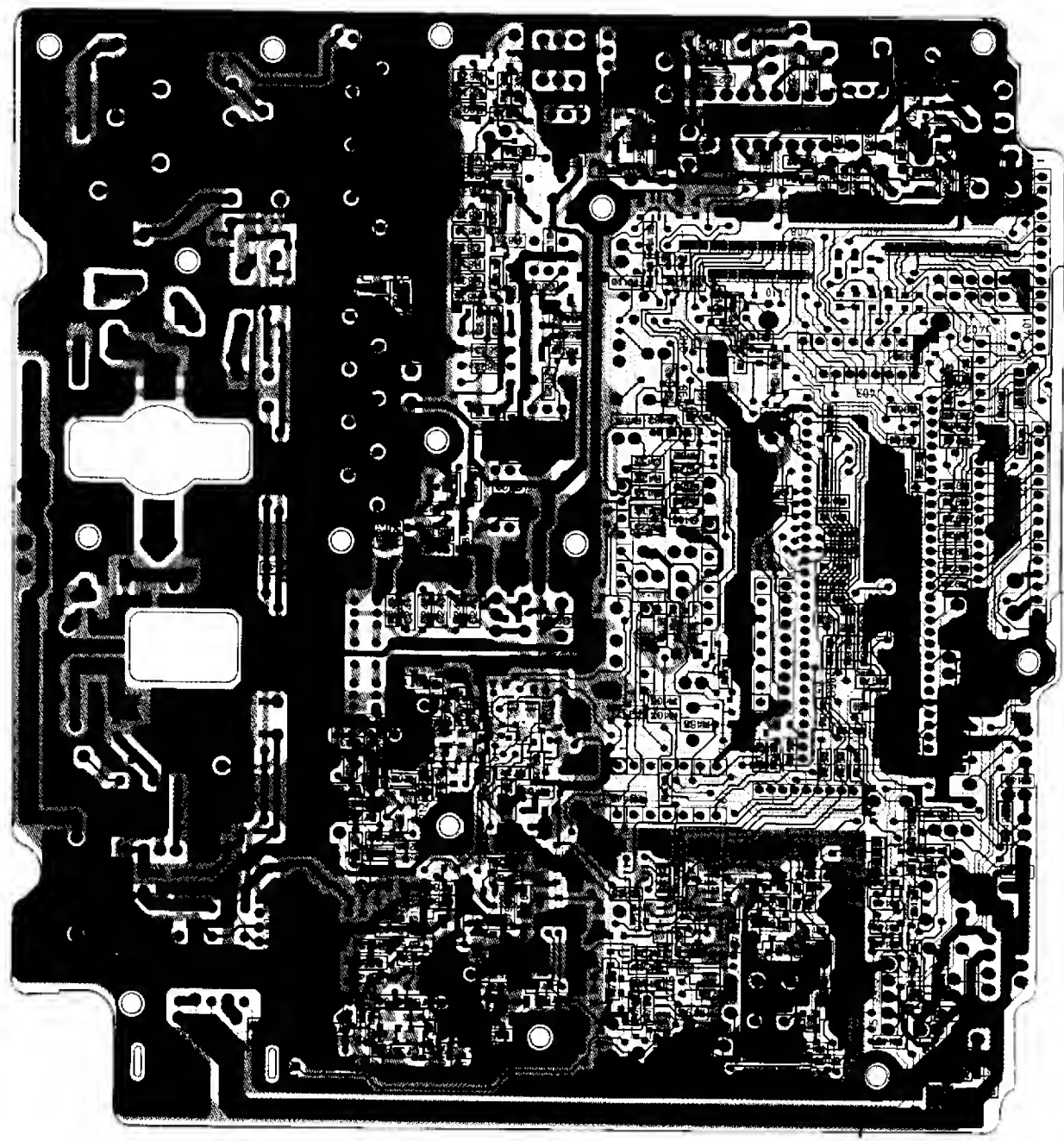
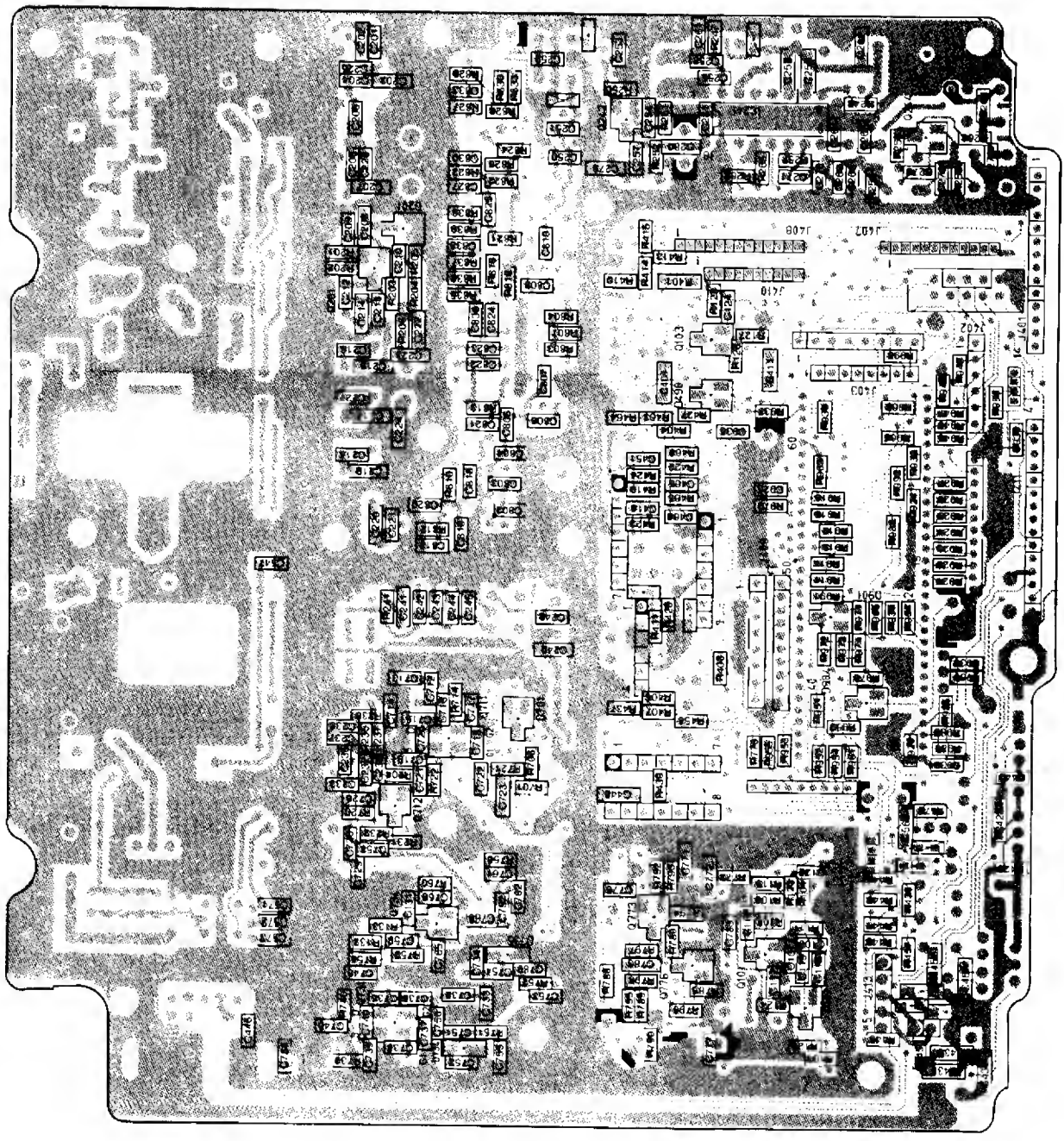

VISIBLE PLATING

UNDERSIDE PLATING



TR-053 LAYOUT--TOP VIEW

70-0371/0375

A

B

C

D

E

F

G

H

I

J

K

L

M

N

1

2

3

4

5

6

7

8

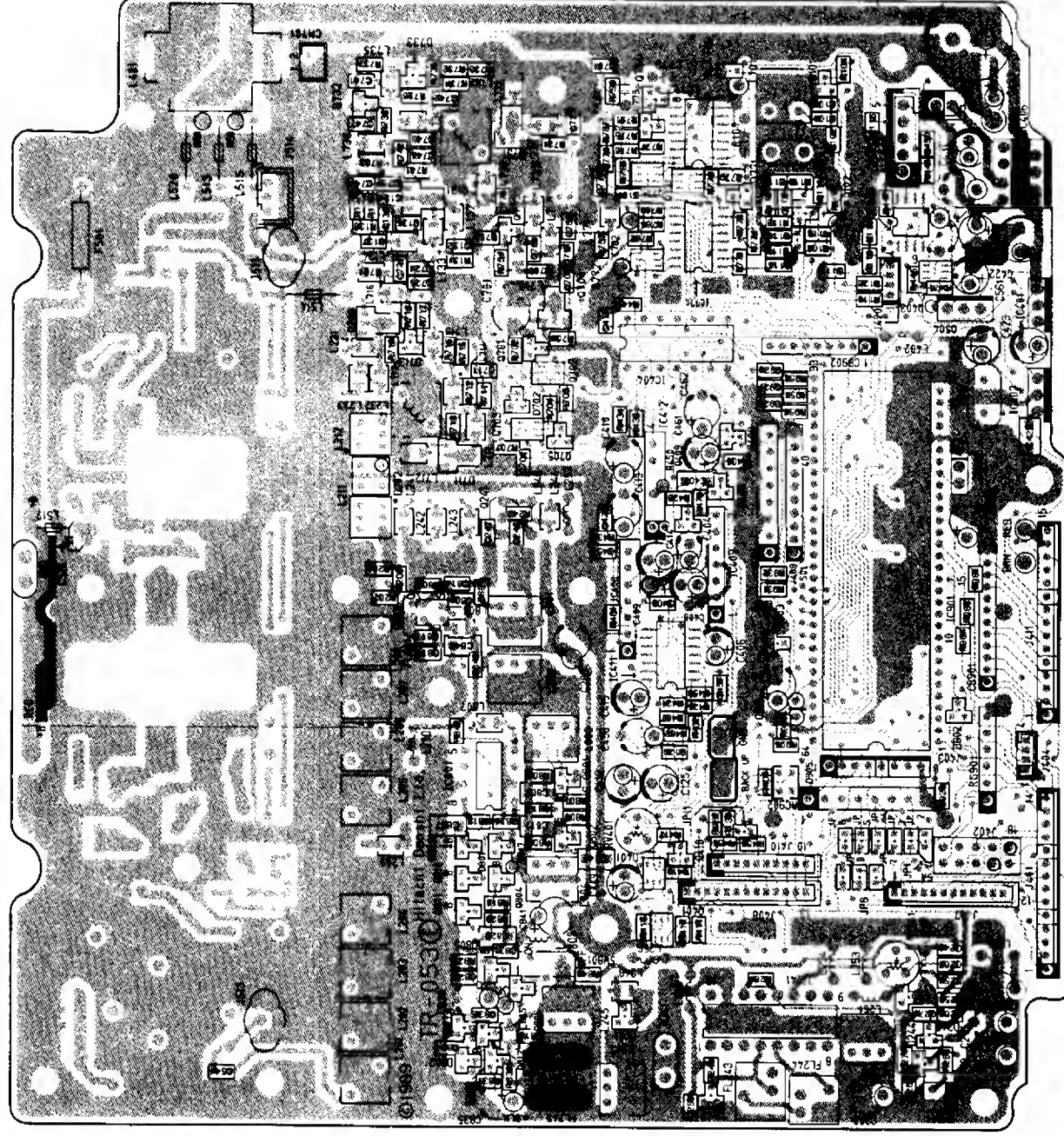
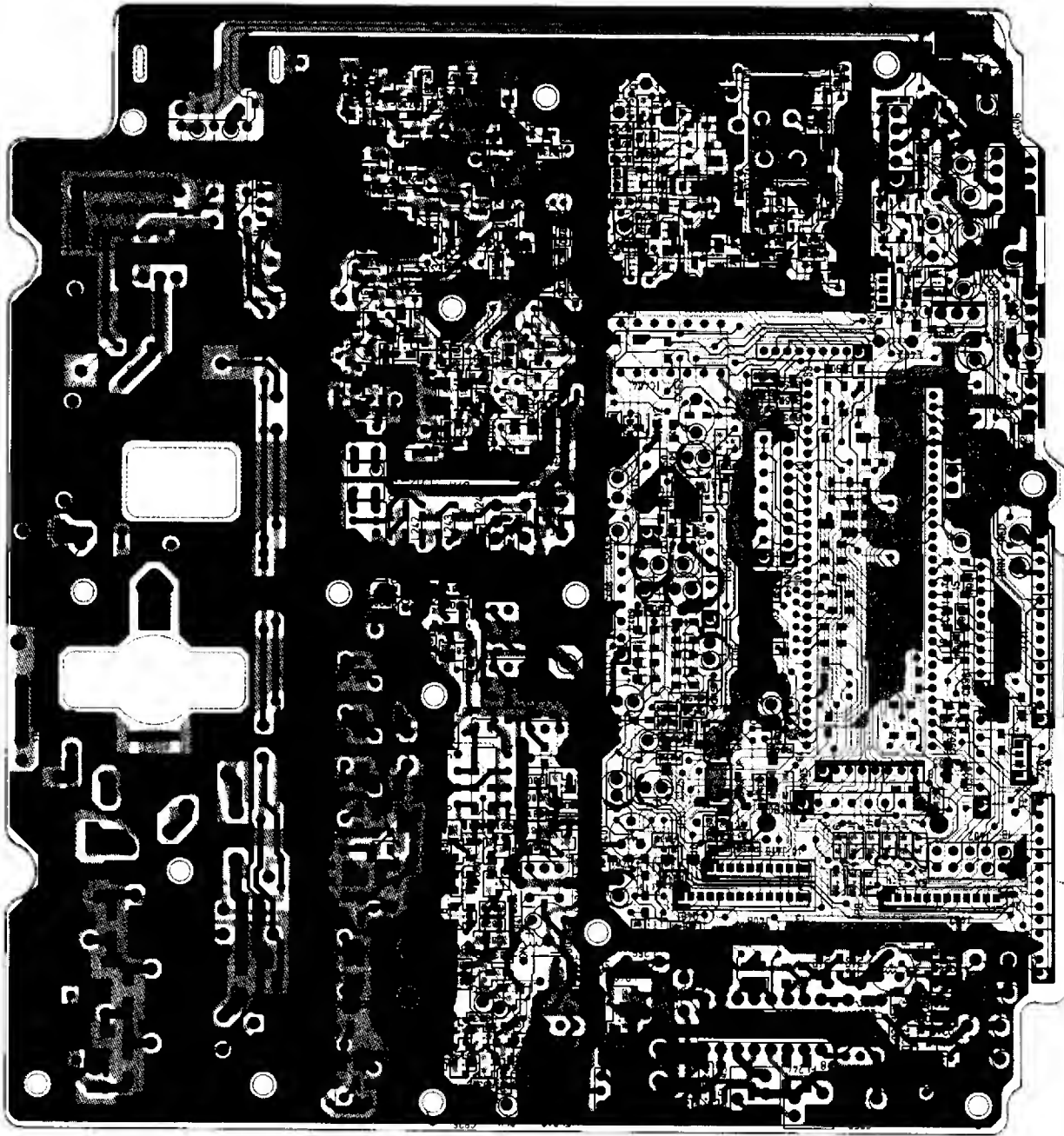

70-0371/0375

A B C D E F G H I J K L M N

1

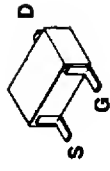

Q242

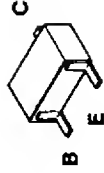

Q101, Q102, Q103, Q201, Q243, Q244, Q406, Q409, Q410, Q701, Q704, Q705, Q712, Q732, Q733, Q734, Q773, Q774, Q775, Q776, Q804, Q805, Q806, Q807, Q808, Q809, Q810, Q811, Q812

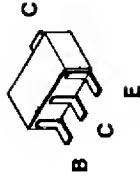

Q131, Q203, Q704



D201, D243, D502, D801

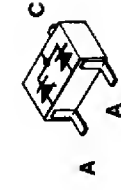

D101, D102, D713, D733, D771, D904



D903

2

3

4

5

6

7

8

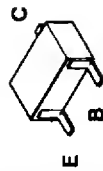

Q408, Q702



Q401, Q403, Q703, Q771, Q772, Q778



Q711, Q731, Q803



D241, D244, D502, D701, D702, D711, D731, D902, D904



D401



D501, D905



Q241



Q504

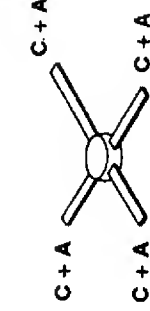

D202

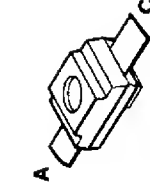

D734, D735

A B C D E F G H I J K L M N

1

2

3

4

5

6

7

8

TOP VIEW

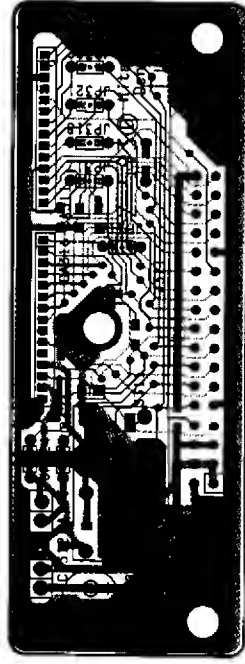

BOTTOM VIEW

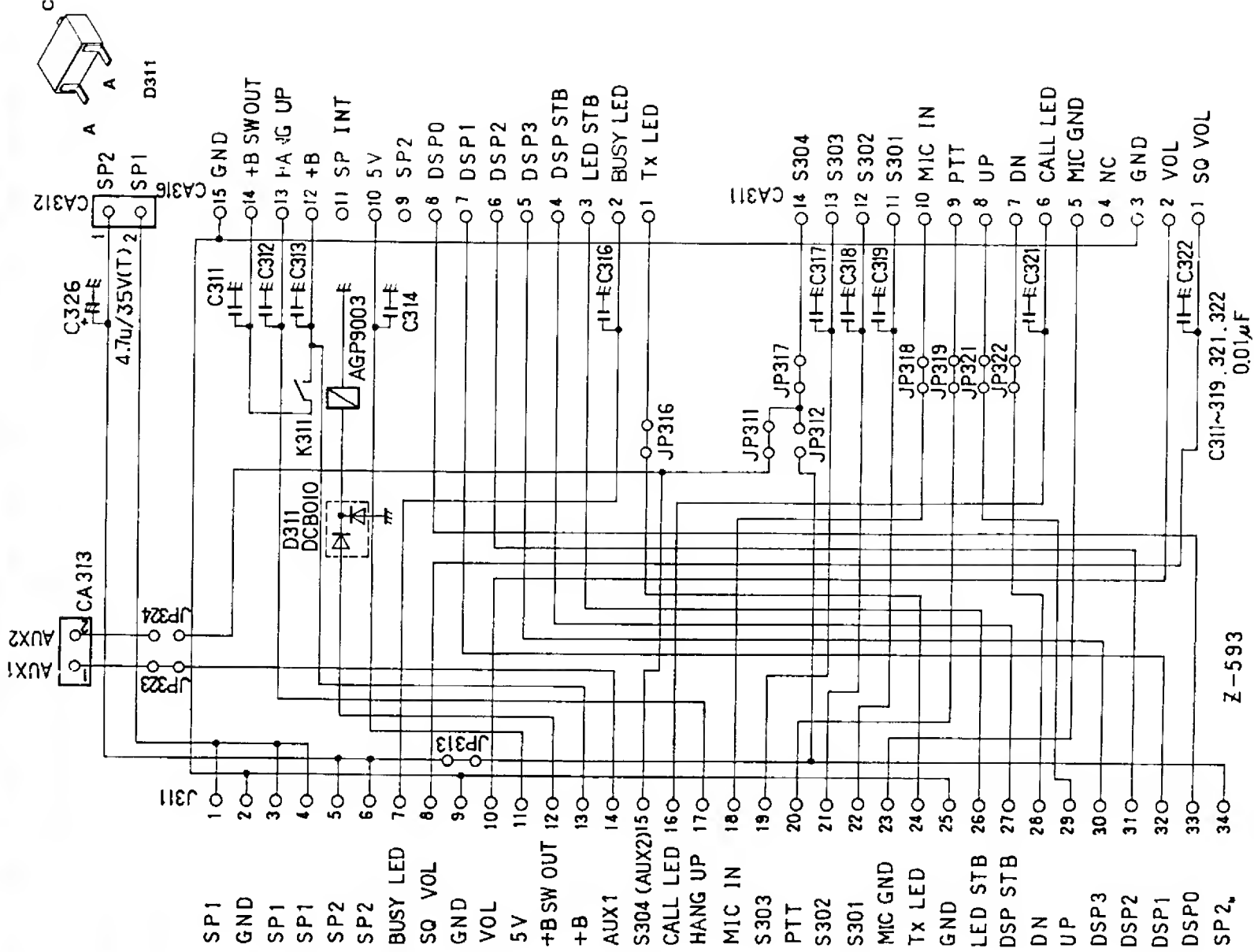
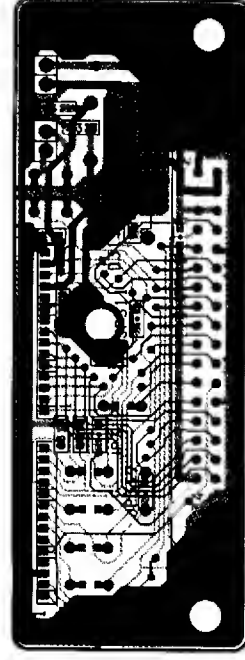

VISIBLE PLATING

UNDERSIDE PLATING

PA-0502 LAYOUT

70-0371/0375

A B C D E F G H I J K L M N

1

2

3

4

5

6

7

8

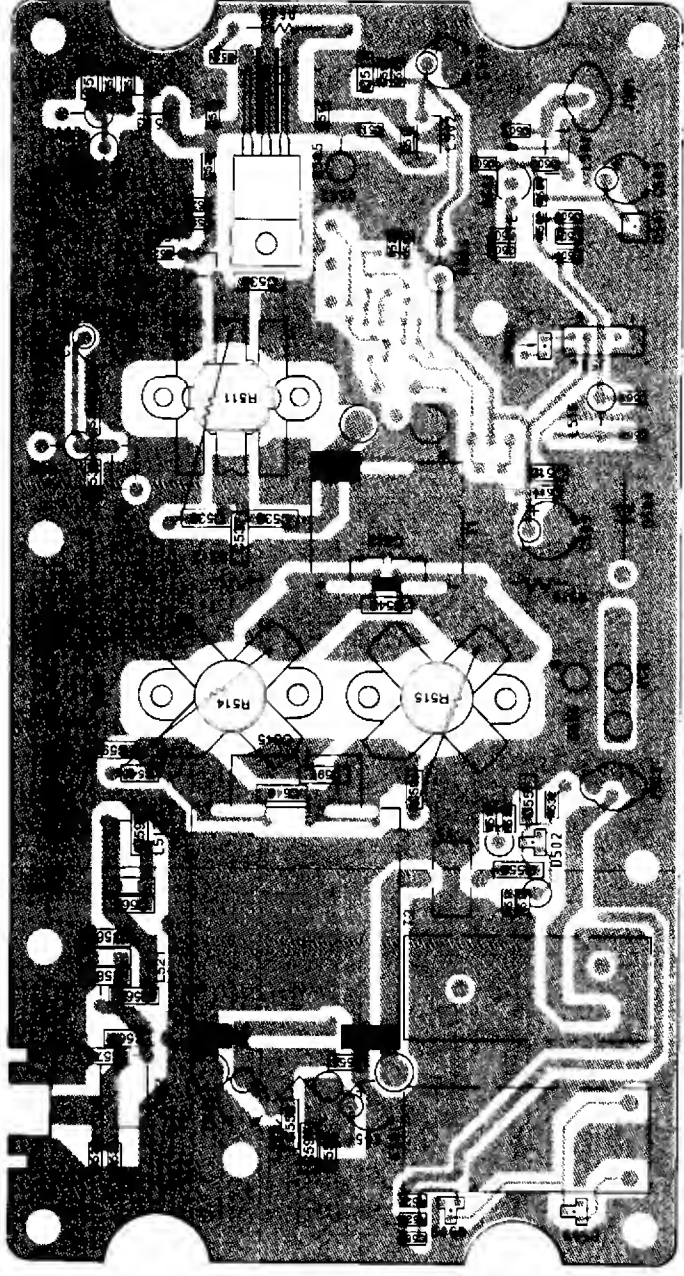
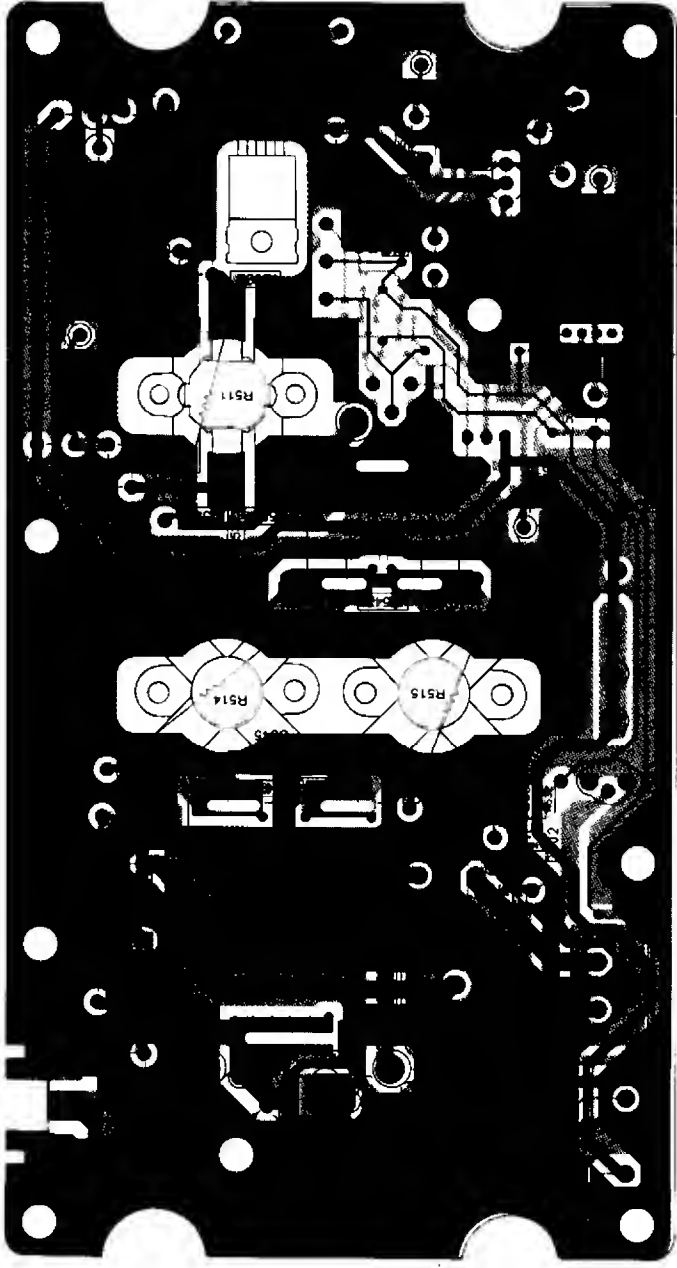

PA-0502 SCHEMATIC DIAGRAM

70-0371/0375

A B C D E F G H I J K L M N

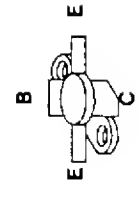
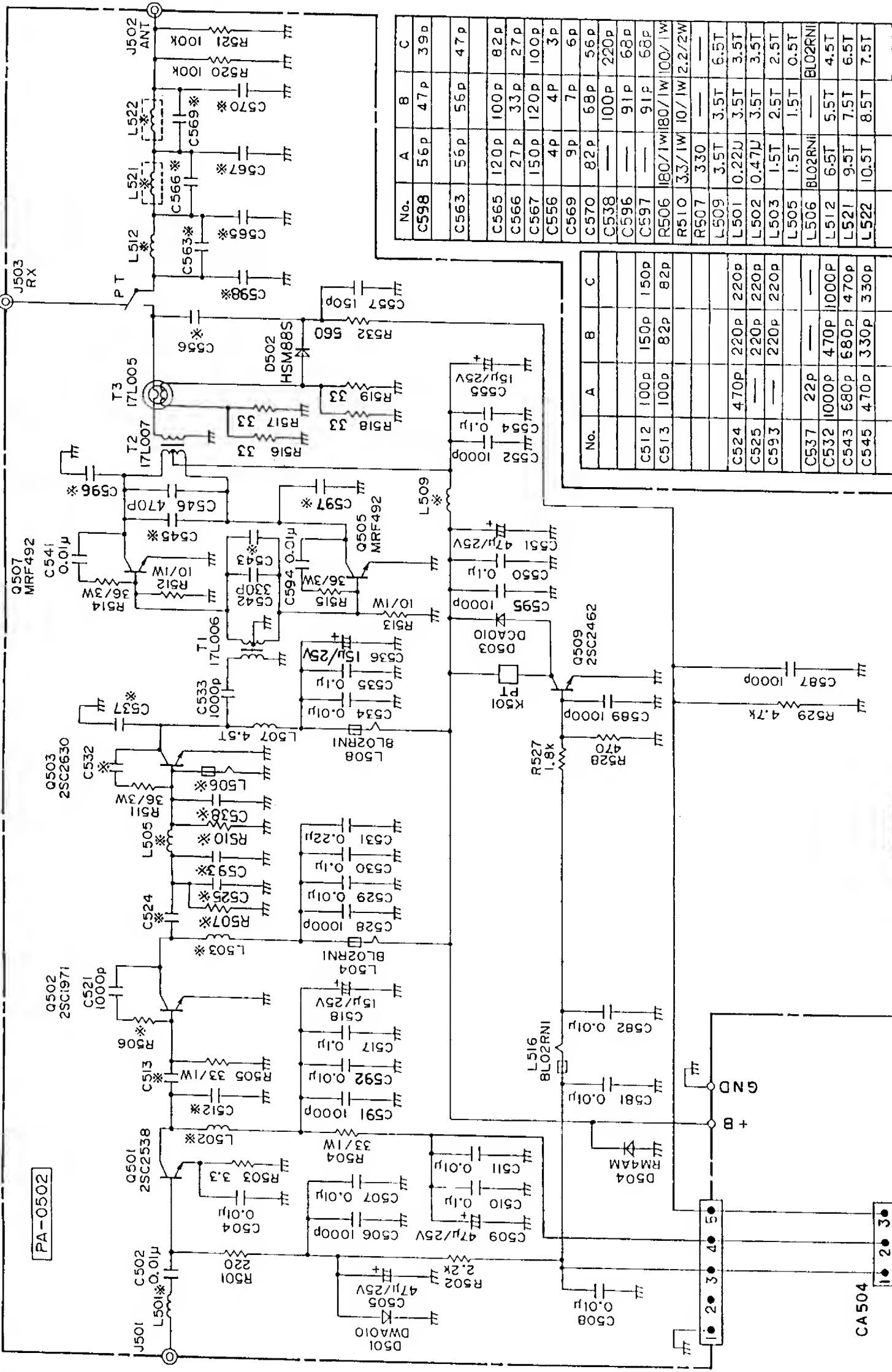

No.	A	B	C
C598	56p	47p	39p
C563	56p	56p	47p
C565	120p	100p	82p
C566	27p	33p	27p
C567	150p	120p	100p
C556	4p	4p	3p
C569	9p	7p	6p
C570	82p	68p	56p
C538	—	100p	220p
C596	—	91p	68p
C597	—	91p	68p
R506	180/1W	180/1W	100/1W
R510	3.3/1W	10/1W	2.2/2W
R507	330	—	—
L509	3.5T	3.5T	6.5T
L501	0.22u	3.5T	3.5T
L502	0.47u	3.5T	3.5T
L503	1.5T	2.5T	2.5T
L505	1.5T	1.5T	0.5T
L506	BLO2RNI	—	BLO2RNI
L512	6.5T	5.5T	4.5T
L521	9.5T	7.5T	6.5T
L522	10.5T	8.5T	7.5T

No.	A	B	C
C512	100p	150p	150p
C513	100p	82p	82p
C524	470p	220p	220p
C525	—	220p	220p
C593	—	220p	220p
C537	22p	—	—
C532	1000p	470p	1000p
C543	680p	680p	470p
C545	470p	330p	330p

1 2 3 4 5 6 7 8

70-0371/0375

A B C D E F G H I J K L M N

1 2 3 4 5 6 7 8

TOP VIEW

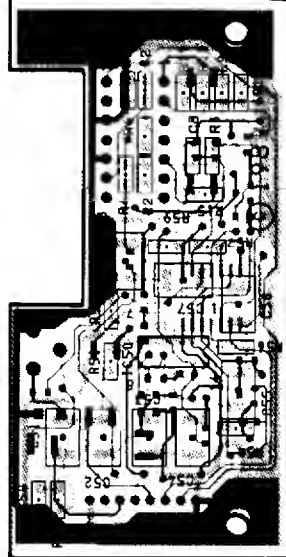

BOTTOM VIEW

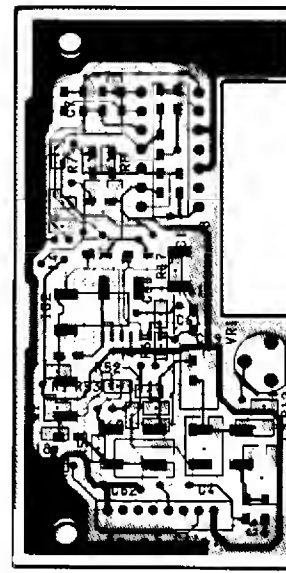

BOTTOM VIEW

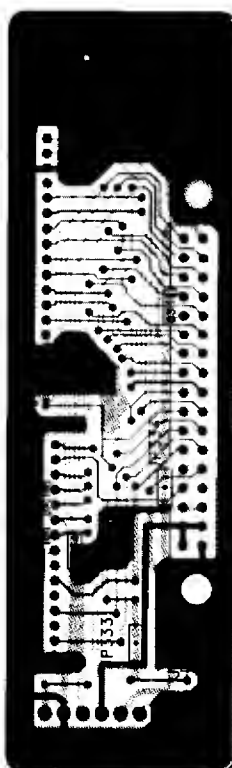

TOP VIEW

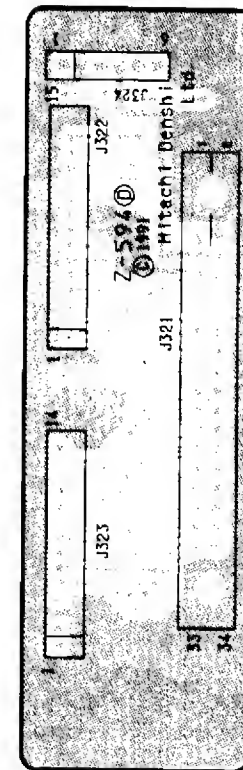
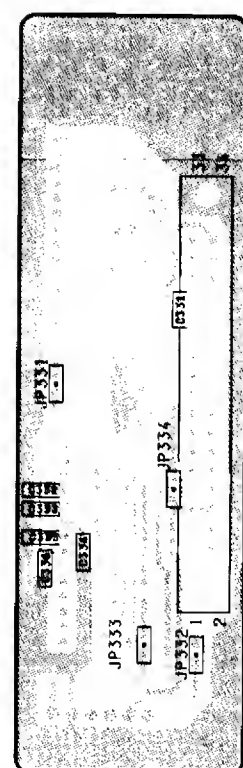
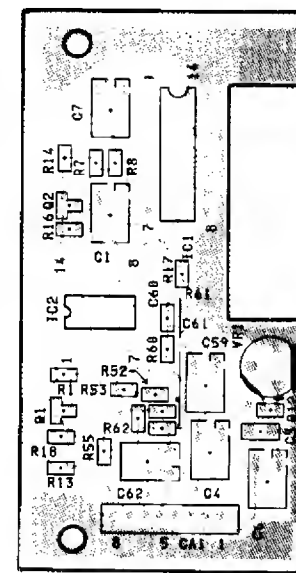
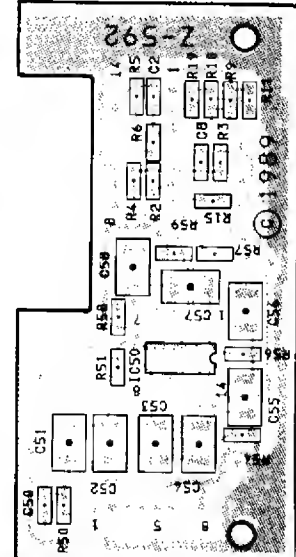
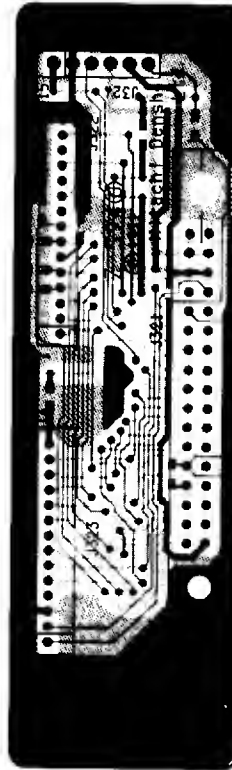

70-2157 CTCSS FILTER BOARD SCHEMATIC

A B C D E F G H I J K L M N

70-0371/0375

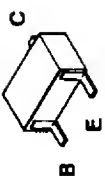
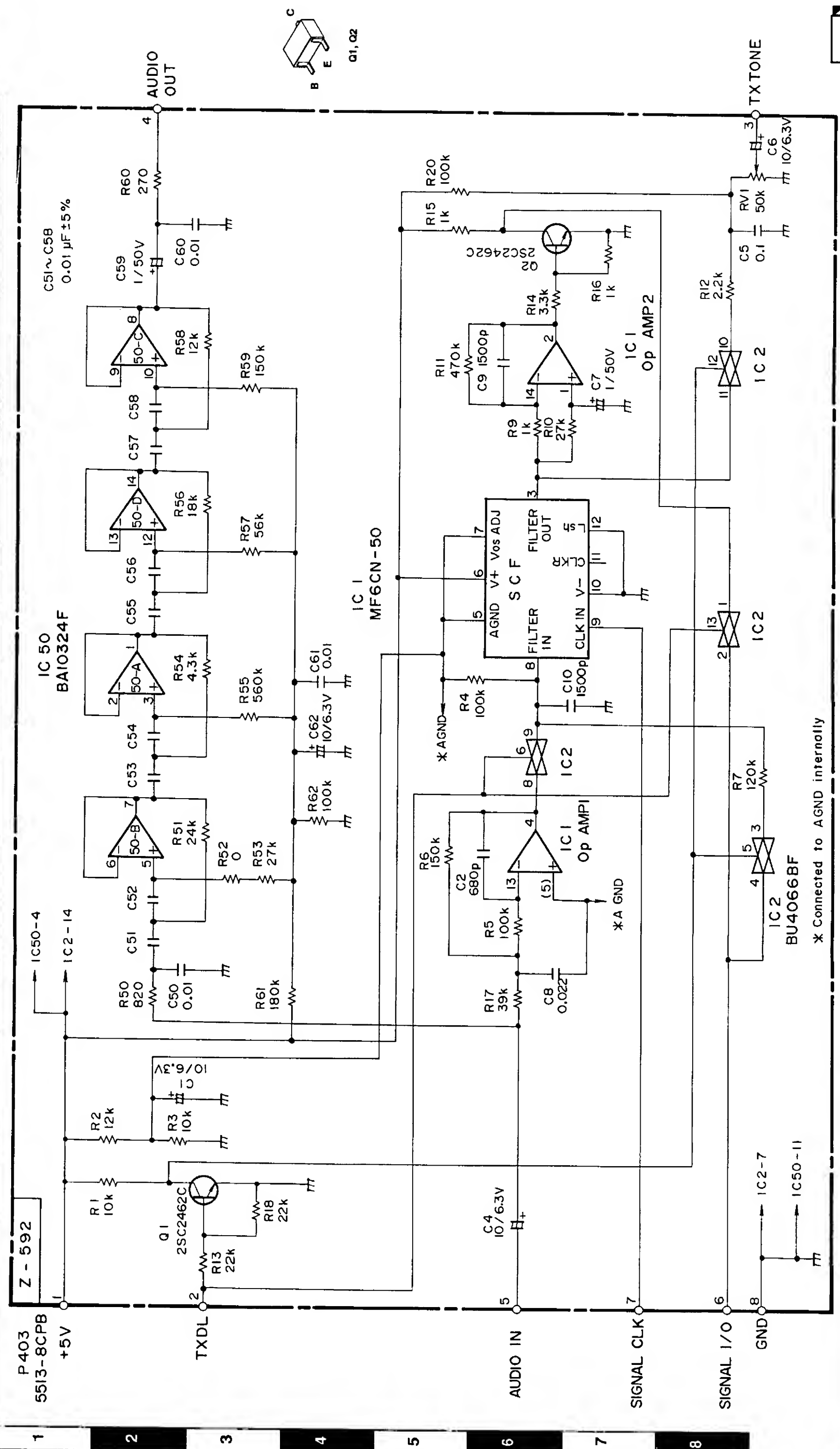

UNDER-DASH EXPLODED VIEW

70-0371/0375

A B C D E F G H I J K L M N

REF NO.	DESCRIPTION	PART NO.
2	COVER	70-010282
4	CLIP	70-150126
5	PROGRAMMER PORT PACKING	70-157358
12	PA SHIELD COVER	70-089340
13	VCO SHIELD CASE	70-089341
14	VCO SHIELD COVER	70-089342
15	LOG SHIELD CASE	70-089343
16	LOG SHIELD COVER	70-089344
22	FRONT COVER ASSY	70-010289
23	SPEAKER BRACKET	70-159324
24	VOLUME KNOB	70-110067
25	VOLUME KNOB	70-110068
26	SWITCH BUTTON	70-110065
38	PCB GUIDE	70-150272
40	VOLUME BRACKET	70-159328
42	LED SPACER	70-150133
50	BRACKET ASSY	70-158327
61	INSULATOR	70-157409
67	SEAL	70-157428
70	CHASSIS	70-010300
71	PA COVER (A)	70-010302
72	PA PACKING	70-157398
73	SHIELD GASKET	70-034330
74	CONNECTOR COVER	70-010304
75	LOCK PLATE	70-010303
78	FE GROUND SPRING	70-152131
80	SPACER B	70-130203
81	SPACER	70-150186
82	SPACER	70-150187
83	HEATSINK PLATE	70-089384
84	SHEET	70-157406
85	HEATSINK PLATE2	70-089382
86	SHEET	70-157407
87	LFF SHIELD	70-089383
88	PA SHIELD CASE	70-089386
89	IF SHIELD	70-157651
90	TUBE	70-150301
93	CLIP2	70-150301
101	SCREW PLAX PAN HD M3 x 10	70-150138
106	SCREW SEMS M3 x 10	70-150180
107	SCREW SEMS M3 x 12	70-150151
109	FIXED SCREW PACK	70-000012
111	SCREW BIND HD M3 x 8	70-150148
112	SCREW FLAT HD M3 x 12	70-150177
113	SCREW FLAT HD M3 x 8	70-150273
114	SCREW BIND HD M3 x 12	70-151836
115	SCREW BIND HD M3 x 10	70-150213
118	SCREW S-TIGHT M3 x 8	70-150151
119	SCREW FLAT HD S-TIGHT M3 x 8	70-150302
119	SCREW FLAT HD M3 x 10	70-150188
J301	NS1504L	70-159100
J502	MF1D62504E-01	70-159427
SP301	SPEAKER	70-080033
G01	TRX LOGIC PCB	TR-063
G02	MIC CONNECTOR PCB	CX-80
G03	DISPLAY PCB	CX-81
G04	OPERATE PCB	CX-82
G07	PA PCB	PA-0502

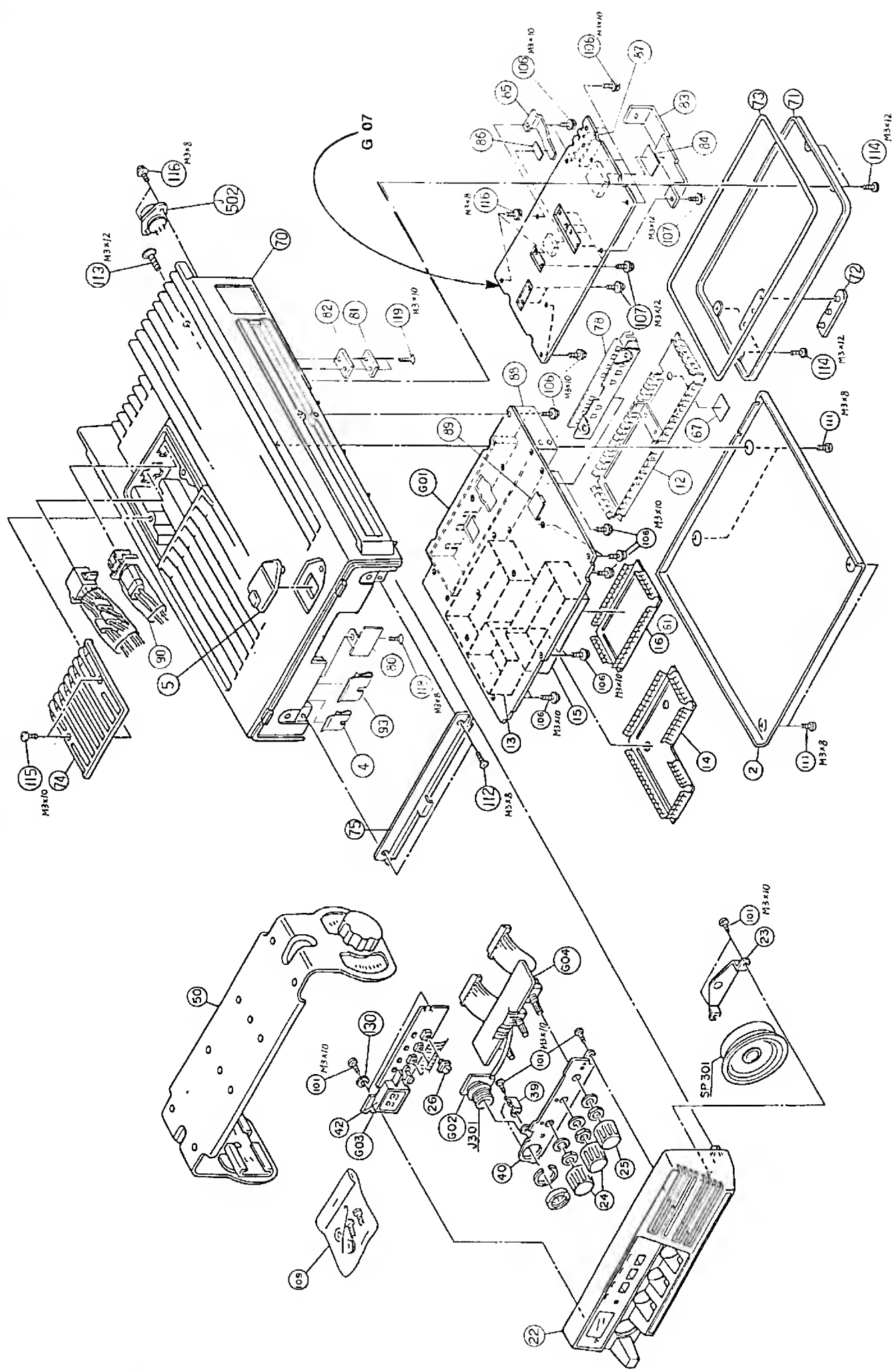

TRUNK-MOUNT EXPLODED VIEW

A B C D E F G H I J K L M N 70-0371/0375

REF NO.	DESCRIPTION	PART NO.
2	COVER	70-010282
4	CUP	70-150128
5	PROGRAMMER PORT PACKING	70-157358
6	BRACKET	70-158323
7	CAP	70-150127
12	PA SHIELD COVER	70-089340
13	VCC SHIELD CASE	70-089341
14	VCC SHIELD COVER	70-089342
15	LOG SHIELD CASE	70-089343
16	LOG SHIELD COVER	70-089344
21	FRONT COVER ASSY	70-010284
24	VOLUME KNOB	70-110066
25	VOLUME KNOB	70-110067
26	SWITCH BUTTON	70-110065
28	CONTROL CASE ASSEMBLY	70-010280
32	CONTROL CHASSIS	70-010287
33	CONTROL COVER	70-010288
34	CONTROL BRACKET	70-158329
35	COIN SCREW	70-150130
36	FIBER WASHER	70-151363
37	RUBBER WASHER	70-151364
38	PCB GUIDE	70-150272
40	VOLUME BRACKET	70-158328
42	LED SPACER	70-150133
44	HANDLE	70-158325
45	HANDLE BASE	70-150132
46	BRACKET ASSY	70-158326
48	INSULATOR	70-157409
61	SEAL	70-157429
67	CHASSIS	70-010300
70	PA COVER (H)	70-010302
71	PA PACKING	70-157386
72	SHIELD TUBE	70-034330
73	CONNECTOR COVER	70-010304
74	LOCK PLATE	70-010303
75	FE GROUND SPRING	70-152131
78	SPACER B	70-150203
80	SPACER	70-150186
81	SPACER	70-150187
82	HEATSINK PLATE	70-089384
83	SHEET	70-157406
84	HEATSINK PLATE2	70-089382
85	SHEET	70-157407
86	LFP S-SHIELD	70-089383
87	PA SHIELD CASE	70-089385
88	IF SHIELD	70-089386
89	TUBE	70-157851
90	CLIP2	70-150301
93	SCREW PLAX PAN HD M3 x 10	70-150136
101	SCREW SEMS PAN HD M3 x 14	70-150181
105	SCREW SEMS M3 x 10	70-150180
106	SCREW SEMS M3 x 12	70-150151
107	FIXED SCREW PACK	70-000013
110	SCREW BIND HD M3 x 8	70-150146
111	SCREW FLAT HD M3 x 8	70-150177
112	SCREW BIND HD M3 x 10	70-150273
113	SCREW FLAT HD M3 x 10	70-150273
114	SCREW BIND HD M3 x 12	70-151839
115	SCREW BIND HD M3 x 10	70-150213
116	SCREW S-TIGHT M3 x 8	70-150151
118	SCREW FLAT HD S-TIGHT M3 x 8	70-150302
119	SCREW FLAT HD M3 x 10	70-150186
CA311	IL-YB-14P-IL-S-14S	70-034627
J501	NS1504L	70-158100
J311	D3431	70-158662
J321	MR-D52504E-01	70-158662
J502	TRK. LOGIC PCB	70-159427
G01	MIC CONNECTOR PCB	TR-053
G02	DISPLAY PCB	CX-90
G03	OPERATE PCB	CX-81
G04	ADAPTOR (HANDLE) PCB	CX-92
G05	ADAPTOR (SMALL REMOTE)	Z-583
G06	PA PCB	Z-584
G07	PA PCB	PA-0502

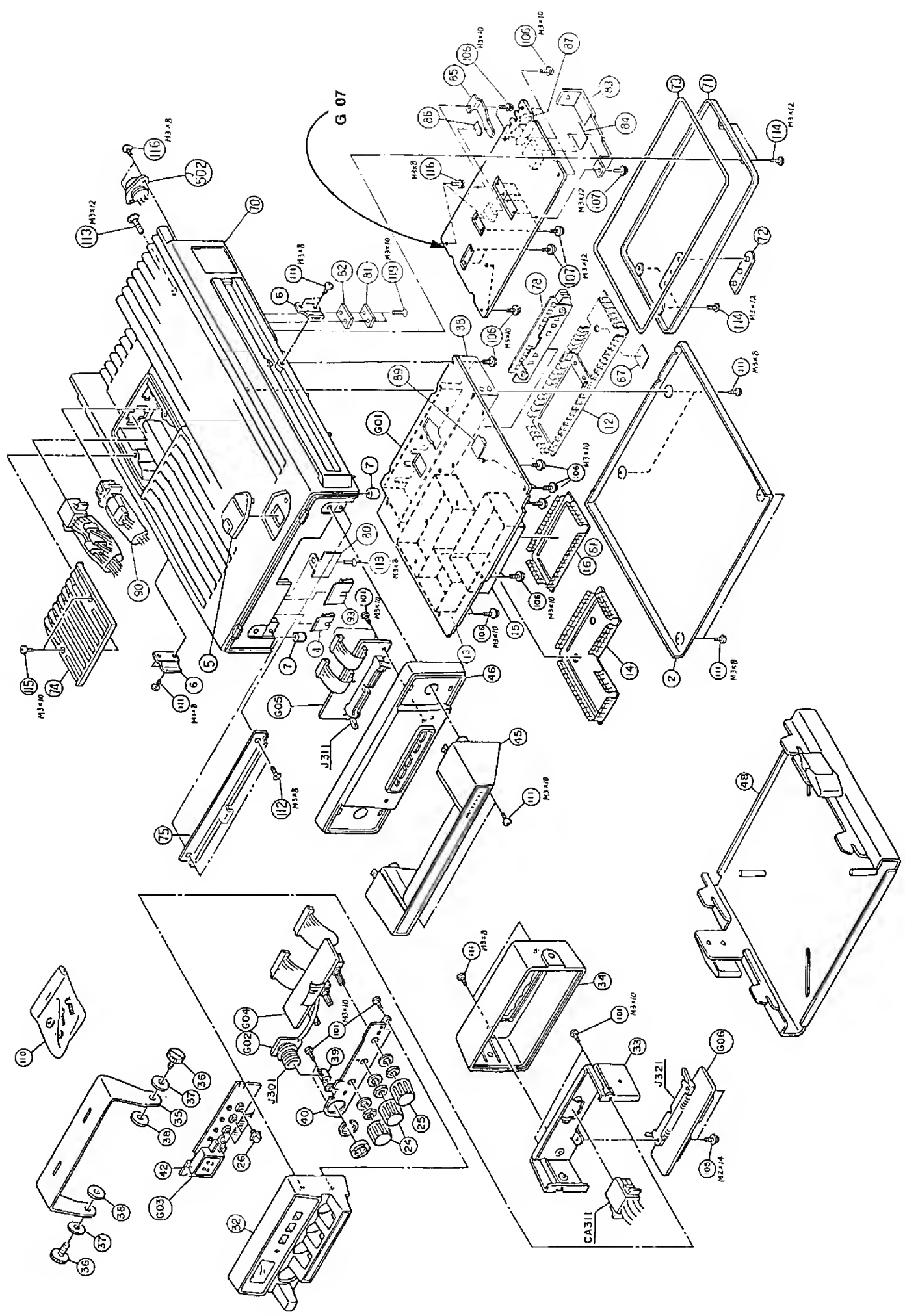

NOTES

SECTION 7

PARTS

PARTS

70-0371/0375

NOTES

MECHANICAL PARTS

U/D = UNDER-DASH T/M = TRUNK-MOUNT		
REF NO.	DESCRIPTION	PART NO.
2	COVER	70-010262
4	CLIP	70-150126
5	PROGRAMMER PORT PACKING	70-157358
6	T/M BRACKET	70-158323
7	T/M CAP	70-150127
12	PA SHIELD COVER	70-089340
13	VCO SHIELD CASE	70-089341
14	VCO SHIELD COVER	70-089342
15	LOG SHIELD CASE	70-089343
16	LOG SHIELD COVER	70-089344
21	T/M FRONT COVER ASSY	70-010264
22	U/D FRONT COVER ASSY	70-010269
23	U/D SPEAKER BRACKET	70-158324
24	U/D VOLUME KNOB	70-110068
25	U/D VOLUME KNOB	70-110067
26	U/D SWITCH BUTTON	70-110065
31	U/D CONTROL CASE ASSEMBLY	70-010266
32	T/M CONTROL CASE ASSEMBLY	70-010290
33	T/M CONTROL CHASSIS	70-010267
34	T/M CONTROL COVER	70-010268
35	T/M CONTROL BRACKET	70-158329
36	T/M COIN SCREW	70-150130
37	T/M FIBER WASHER	70-151363
38	T/M RUBBER WASHER	70-151364
39	PCB GUIDE	70-150272
40	VOLUME BRACKET	70-158328
42	LED SPACER	70-150133
45	T/M HANDLE	70-158325
46	T/M HANDLE BASE	70-150132
48	T/M BRACKET ASSY	70-158326
50	U/D BRACKET ASSY	70-158327
61	INSULATOR	70-157409
67	SEAL	70-157429
70	CHASSIS	70-010300
71	PA COVER (H)	70-010302
72	PA PACKING	70-157368
73	SHIELD TUBE	70-034330
74	CONNECTOR COVER	70-010304
75	LOCK PLATE	70-010303
78	FE GROUND SPRING	70-152131
80	SPACER B	70-150203
81	SPACER	70-150186
82	SPACER	70-150187
83	HEATSINK PLATE	70-089384
84	SHEET	70-157406
85	HEATSINK PLATE2	70-089362
86	SHEET	70-157407
87	LPF SHIELD	70-089363
88	PA SHIELD CASE	70-089363
90	TUBE	70-157651
89	IF SHIELD	70-089366
101	SCREW FLAX PAN HD M3 x 10	70-150136
105	T/M SCREW SEMS PAN HD M3 x 14	70-150191
106	SCREW SEMS M3 x 10	70-150180
107	SCREW SEMS M3 x 12	70-150151
109	U/D FIXED SCREW PACK	70-000012
110	T/M FIXED SCREW PACK	70-000013
111	SCREW BIND HD M3 x 8	70-150146
112	SCREW FLAT HD M3 x 8	70-150177
113	SCREW FLAT HD M3 x 10	70-150273
114	SCREW BIND HD M3 x 12	70-151839
115	SCREW BIND HD M3 x 10	70-150213
117	SCREW FLAT HD M3 x 10	70-150186
G01	TRX, LOGIC PCB	TR-053
G02	MIC CONNECTOR PCB	CX-90
G03	DISPLAY PCB	CX-91
G04	OPERATE PCB	CX-92
G05	T/M ADAPTOR (HANDLE) PCB	Z-593
G06	T/M ADAPTOR (SMALL REMOTE)	Z-594
G07	PA PCB	PA-0502

PARTS

70-0371/0375

TR-053 BOARD

70-0371/0375 A BAND USE "A"			70-0371/0375 B BAND USE "B"			70-0371/0375 C BAND USE "C"		
REF NO.	DESCRIPTION	PART NO.	REF NO.	DESCRIPTION	PART NO.			
CAPACITORS			CAPACITORS (CONTINUED)					
C102	47 pF, 50 V, CER	70-138185	C217 A	680 pF, 50 V, CER	70-138252			
C103	1000 pF, 50 V, CER	70-138255	C217 B	680 pF, 50 V, CER	70-138252			
C104	100 pF, 50 V, CER	70-138364	C217 C	560 pF, 50 V, CER	70-138407			
C106	22 pF, 50 V, CER	70-138171	C218 A	270 pF, 50 V, CER	70-138403			
C107	27 pF, 50 V, CER	70-138185	C218 B	180 pF, 50 V, CER	70-138230			
C108	0.022 uF, 50 V, CER	70-138182	C218 C	130 pF, 50 V, CER	70-138406			
C109	1000 pF, 50 V, CER	70-138255	C219 A	750 pF, 50 V, CER	70-138405			
C110	10 pF, 50 V, CER	70-138187	C219 B	560 pF, 50 V, CER	70-138407			
C111	0.022 uF, 50 V, CER	70-138182	C219 C	470 pF, 50 V, CER	70-138404			
C112	0.022 uF, 50 V, CER	70-138182	C220 A	750 pF, 50 V, CER	70-138405			
C113	47 pF, 50 V, CER	70-138185	C220 B	390 pF, 50 V, CER	70-138363			
C114	47 pF, 50 V, CER	70-138185	C220 C	220 pF, 50 V, CER	70-138176			
C115	1000 pF, 50 V, CER	70-138255	C221 A	270 pF, 50 V, CER	70-138403			
C116	0.022 uF, 50 V, CER	70-138182	C221 B	220 pF, 50 V, CER	70-138176			
C117	120 pF, 50 V, CER	70-138303	C221 C	180 pF, 50 V, CER	70-138230			
C118	120 pF, 50 V, CER	70-138303	C222	0.01 uF, 50 V, CER	70-138270			
C119	1000 pF, 50 V, CER	70-138255	C223	0.01 uF, 50 V, CER	70-138270			
C122	1000 pF, 50 V, CER	70-138255	C224	0.01 uF, 50 V, CER	70-138270			
C124	1000 pF, 50 V, CER	70-138255	C232 A	56 pF, 50 V, CER	70-138254			
C125	10 uF, 16 V, AL, ELYC	70-138191	C232 B	47 pF, 50 V, CER	70-138185			
C131	0.022 uF, 50 V, CER	70-138182	C232 C	33 pF, 50 V, CER	70-138188			
C132	4700 pF, 50 V, CER	70-138183	C233	4700 pF, 50 V, CER	70-138183			
C134	100 pF, 50 V, CER	70-138175	C235	100 pF, 50 V, CER	70-138175			
C136 A	220 pF, 50 V, CER	70-138349	C237 A	39 pF, 50 V, CER	70-138233			
C136 B	150 pF, 50 V, CER	70-138231	C237 B	33 pF, 50 V, CER	70-138188			
C136 C	100 pF, 50 V, CER	70-138175	C237 C	22 pF, 50 V, CER	70-138171			
C137	100 pF, 50 V, CER	70-138175	C238	100 pF, 50 V, CER	70-138175			
C137	100 pF, 50 V, CER	70-138175	C239	0.022 uF, 50 V, CER	70-138182			
C138 A	100 pF, 50 V, CER	70-138175	C241	560 pF, 50 V, CER	70-138407			
C138 B	68 pF, 50 V, CER	70-138229	C242	82 pF, 50 V, CER	70-138250			
C138 C	100 pF, 50 V, CER	70-138175	C243	270 pF, 50 V, CER	70-138403			
C201 A	270 pF, 50 V, CER	70-138403	C244	82 pF, 50 V, CER	70-138250			
C201 B	180 pF, 50 V, CER	70-138230	C245	22 pF, 50 V, CER	70-138171			
C201 C	150 pF, 50 V, CER	70-138231	C246	0.022 uF, 50 V, CER	70-138182			
C202 A	750 pF, 50 V, CER	70-138405	C247	0.022 uF, 50 V, CER	70-138182			
C202 B	470 pF, 50 V, CER	70-138404	C248	0.022 uF, 50 V, CER	70-138182			
C202 C	270 pF, 50 V, CER	70-138403	C249	0.022 uF, 50 V, CER	70-138182			
C203 A	680 pF, 50 V, CER	70-138252	C250	150 pF, 50 V, CER	70-138231			
C203 B	470 pF, 50 V, CER	70-138404	C251	330 pF, 50 V, CER	70-138228			
C203 C	390 pF, 50 V, CER	70-138363	C252	7 pF, 50 V, CER	70-138181			
C204 A	100 pF, 50 V, CER	70-138175	C253	66 pF, 50 V, CER	70-138226			
C204 B	130 pF, 50 V, CER	70-138406	C254	0.022 uF, 50 V, CER	70-138182			
C204 C	100 pF, 50 V, CER	70-138175	C255	47 pF, 50 V, CER	70-138185			
C205 A	33 pF, 50 V, CER	70-138186	C256	100 pF, 50 V, CER	70-138175			
C205 B	22 pF, 50 V, CER	70-138171	C257	22 pF, 50 V, CER	70-138171			
C205 C	15 pF, 50 V, CER	70-138205	C258	0.1 uF, 25 V, CER	70-138327			
C206 A	100 pF, 50 V, CER	70-138175	C259	0.1 uF, 25 V, CER	70-138327			
C206 B	130 pF, 50 V, CER	70-138406	C260	0.01 pF, 50 V, CER	70-138270			
C206 C	100 pF, 50 V, CER	70-138175	C261	0.022 uF, 50 V, CER	70-138182			
C207 A	680 pF, 50 V, CER	70-138252	C262	0.022 uF, 50 V, CER	70-138182			
C207 B	470 pF, 50 V, CER	70-138404	C263	120 uF, 16 V, AL, ELYC	70-135187			
C207 C	380 pF, 50 V, CER	70-138363	C264	0.022 uF, 50 V, CER	70-138182			
C208 A	820 pF, 50 V, CER	70-138406	C265	4700 pF, 50 V, CER	70-138183			
C208 B	560 pF, 50 V, CER	70-138407	C266	0.022 uF, 50 V, CER	70-138182			
C208 C	470 pF, 50 V, CER	70-138404	C267	0.022 uF, 50 V, CER	70-138182			
C209 A	270 pF, 50 V, CER	70-138403	C268	6800 pF, 50 V, CER	70-138173			
C209 B	180 pF, 50 V, CER	70-138230	C269	2200 pF, 50 V, CER	70-138235			
C209 C	120 pF, 50 V, CER	70-138303	C270	6800 pF, 50 V, CER	70-138173			
C210	0.01 uF, 50 V, CER	70-138270	C271	4700 pF, 50 V, CER	70-138183			
C212 A	66 pF, 50 V, CER	70-138229	C272	1000 pF, 50 V, CER	70-138255			
C212 B	0.01 uF, 50 V, CER	70-138270	C273	0.047 uF, 16 V, CER	70-138406			
C212 C	0.01 uF, 50 V, CER	70-138270	C274	4700 pF, 50 V, CER	70-138183			
C213 A	270 pF, 50 V, CER	70-138403	C275	1 uF, 35 V, TA, ELYC	70-136067			
C213 B	220 pF, 50 V, CER	70-138176	C276	0.022 pF, 50 V, CER	70-138182			
C213 C	180 pF, 50 V, CER	70-138230	C277	1000 pF, 50 V, CER	70-138255			
C214 A	750 pF, 50 V, CER	70-138405	C278	1 uF, 50 V, AL, ELYC	70-135147			
C214 B	470 pF, 50 V, CER	70-138404	C279	0.022 uF, 50 V, CER	70-138182			
C214 C	270 pF, 50 V, CER	70-138403	C280	1000 pF, 50 V, CER	70-138255			
C215 A	750 pF, 50 V, CER	70-138405	C281	47 pF, 50 V, CER	70-138185			
C215 B	560 pF, 50 V, CER	70-138407	C283	47 uF, 25 V, AL, ELYC	70-135144			
C215 C	470 pF, 50 V, CER	70-138404	C284	0.022 uF, 50 V, CER	70-135182			
C216 A	270 pF, 50 V, CER	70-138403	C285	220 uF, 25 V, AL, ELYC	70-131300			
C216 B	180 pF, 50 V, CER	70-138230	C401	0.1 uF, 25 V, CER	70-138327			
C216 C	130 pF, 50 V, CER	70-138406	C403	220 pF, 50 V, CER	70-138349			

TR-053 BOARD (CONTINUED)

REF NO.	DESCRIPTION	PART NO.	REF NO.	DESCRIPTION	PART NO.
CAPACITORS (CONTINUED)			CAPACITORS (CONTINUED)		
C404	10 uF, 16 V, AL, ELYC	70-138191	C727	22 pF, 50 V, CER	70-138171
C406	10 uF, 16 V, AL, ELYC	70-138191	C730	100 pF, 50 V, CER	70-138175
C407	0.047 uF, 50 V, CER	70-131298	C731	4700 pF, 50 V, CER	70-138183
C408	1 uF, 50 V, AL, ELYC	70-138194	C732	150 pF, 50 V, CER	70-138231
C409	220 uF, 16 V, AL, ELYC	70-135164	C733 A	5 pF, 50 V, CER	70-137085
C410	220 uF, 10 V, CER	70-135217	C733 B	6 pF, 50 V, CER	70-138210
C411	0.022 uF, 50 V, CER	70-132033	C733 C	6 pF, 50 V, CER	70-138210
C412	10 uF, 16 V, AL, ELYC	70-138191	C734 A	330 pF, 50 V, CER	70-138228
C413	10 uF, 16 V, AL, ELYC	70-138191	C734 B	330 pF, 50 V, CER	70-138228
C414	10 uF, 16 V, AL, ELYC	70-138191	C734 C	220 pF, 50 V, CER	70-138178
C415	10 uF, 16 V, AL, ELYC	70-138191	C735	10 pF, 50 V, CER	70-138167
C416	82 pF, 50 V, CER	70-138250	C736 A	220 pF, 50 V, CER	70-138176
C417	0.01 uF, 50 V, CER	70-138270	C736 B	220 pF, 50 V, CER	70-138176
C422	220 uF, 25 V, AL, ELYC	70-135166	C736 C	180 pF, 50 V, CER	70-138230
C423	10 uF, 16 V, AL, ELYC	70-138191	C737	4700 pF, 50 V, CER	70-138183
C424	10 uF, 16 V, AL, ELYC	70-138191	C738	4700 pF, 50 V, CER	70-138183
C425	1000 pF, 50 V, CER	70-138255	C739 A	100 pF, 50 V, CER	70-138175
C426	0.01 uF, 50 V, CER	70-138270	C739 B	120 pF, 50 V, CER	70-138303
C428	0.1 uF, 25 V, CER	70-138327	C739 C	100 pF, 50 V, CER	70-138175
C429	0.1 uF, 25 V, CER	70-138327	C740 A	100 pF, 50 V, CER	70-138175
C430	0.1 uF, 25 V, CER	70-138327	C740 B	120 pF, 50 V, CER	70-138303
C431	1 uF, 50 V, AL, ELYC	70-138194	C740 C	100 pF, 50 V, CER	70-138175
C432	22 uF, 16 V, AL, ELYC	70-135220	C741	3 pF, 50 V, CER	70-138164
C433	22 uF, 16 V, AL, ELYC	70-135220	C742	0.022 uF, 50 V, CER	70-138162
C434	2200 uF, 25 V, AL, ELYC	70-135235	C743	4700 pF, 50 V, CER	70-138163
C436	220 uF, 10 V, AL, ELYC	70-135217	C744	0.022 uF, 50 V, CER	70-138162
C438	0.1 uF, 25 V, CER	70-138327	C745	4700 pF, 50 V, CER	70-138163
C439	0.1 uF, 25 V, CER	70-138327	C746	4700 pF, 50 V, CER	70-138163
C443	0.01 uF, 50 V, CER	70-138270	C747	10 pF, 50 V, CER	70-138197
C446	1000 pF, 50 V, CER	70-138255	C750	100 pF, 50 V, CER	70-138175
C448	0.1 uF, 25 V, CER	70-138327	C751 A	8 pF, 50 V, CER	70-138186
C449	4.7 uF, 16 V, TA, ELYC	70-138101	C751 B	7 pF, 50 V, CER	70-138181
C450	1000 pF, 50 V, CER	70-138255	C751 C	6 pF, 50 V, CER	70-138210
C451	82 pF, 50 V, CER	70-138250	C752 A	27 pF, 50 V, CER	70-138165
C452	0.022 uF, 50 V, CER	70-138162	C752 B	16 pF, 50 V, CER	70-138208
C457	220 pF, 50 V, CER	70-138176	C752 C	22 pF, 50 V, CER	70-138171
C458	220 pF, 50 V, CER	70-138176	C753	2200 pF, 50 V, CER	70-138235
C461	10 uF, 16 V, AL, ELYC	70-138191	C754 A	36 pF, 50 V, CER	70-138233
C462	10 uF, 16 V, AL, ELYC	70-138191	C754 B	33 pF, 50 V, CER	70-138168
C465	100 pF, 50 V, CER	70-138175	C754 C	27 pF, 50 V, CER	70-138185
C466	220 pF, 50 V, CER	70-138176	C755	2200 pF, 50 V, CER	70-138235
C467	0.1 uF, 25 V, CER	70-138327	C756 A	8 pF, 50 V, CER	70-138203
C468	4.7 uF, 35 V, TA, ELYC	70-138066	C756 B	7 pF, 50 V, CER	70-138181
C515	1000 pF, 50 V, CER	70-138255	C756 C	6 pF, 50 V, CER	70-138210
C516	0.01 pF, 50 V, CER	70-138270	C758	3 pF, 50 V, CER	70-138164
C528	2200 uF, 25 V, AL, ELYC	70-135235	C759	3 pF, 50 V, CER	70-138164
C544	0.01 uF, 50 V, CER	70-138270	C760	4700 pF, 50 V, CER	70-138163
C547	1000 pF, 50 V, CER	70-138255	C761	4700 pF, 50 V, CER	70-138163
C548	1000 pF, 50 V, CER	70-138255	C762 A	15 pF, 50 V, CER	70-138205
C549	0.01 uF, 50 V, CER	70-138270	C762 B	8 pF, 50 V, CER	70-138210
C560	0.1 uF, 25 V, CER	70-138327	C762 C	3 pF, 50 V, CER	70-138164
C561	10 uF, 25 V, AL, ELYC	70-135173	C763	15 pF, 50 V, CER	70-138205
C701	47 uF, 16 V, AL, ELYC	70-135219	C765	4700 pF, 50 V, CER	70-138163
C702	0.022 uF, 50 V, CER	70-138162	C766	4700 pF, 50 V, CER	70-138163
C703	1000 pF, 50 V, CER	70-138255	C768	6 pF, 50 V, CER	70-138203
C711	4700 pF, 50 V, CER	70-138183	C769 A	220 pF, 50 V, CER	70-138349
C712 A	68 pF, 50 V, CER	70-138229	C769 B	100 pF, 50 V, CER	70-138175
C712 B	56 pF, 50 V, CER	70-138254	C769 C	100 pF, 50 V, CER	70-138175
C712 C	56 pF, 50 V, CER	70-138254	C770 A	56 pF, 50 V, CER	70-138254
C713	10 pF, 50 V, CER	70-138187	C770 B	33 pF, 50 V, CER	70-138186
C714	4700 pF, 50 V, CER	70-138183	C770 C	22 pF, 50 V, CER	70-138171
C715	22 pF, 50 V, CER	70-138171	C771	0.022 uF, 50 V, CER	70-138162
C716 A	150 pF, 50 V, CER	70-138231	C772	0.1 uF, 25 V, CER	70-138327
C716 B	100 pF, 50 V, CER	70-138175	C773	68 pF, 50 V, CER	70-138229
C716 C	100 pF, 50 V, CER	70-138175	C775	0.022 uF, 50 V, CER	70-138162
C717	4700 pF, 50 V, CER	70-138183	C776	47 uF, 25 V, AL, ELYC	70-135144
C718	4700 pF, 50 V, CER	70-138183	C777	1000 pF, 50 V, CER	70-138255
C719 A	100 pF, 50 V, CER	70-138175	C778	0.022 uF, 50 V, CER	70-138162
C719 B	68 pF, 50 V, CER	70-138229	C779	0.1 uF, 50 V, PLAS	70-138189
C719 C	68 pF, 50 V, CER	70-138229	C781	1000 pF, 50 V, CER	70-138255
C720 A	100 pF, 50 V, CER	70-138175	C782	1 uF, 63 V, PLAS	70-137101
C720 B	68 pF, 50 V, CER	70-138229	C783	0.022 uF, 50 V, CER	70-138162
C720 C	68 pF, 50 V, CER	70-138229	C784	0.1 uF, 50 V, PLAS	70-138189
C721	2 pF, 50 V, CER	70-138189	C785	0.022 uF, 50 V, CER	70-138162
C722	4700 pF, 50 V, CER	70-138183	C787	1000 pF, 50 V, CER	70-138255
C723	0.1 uF, 25 V, CER	70-138327	C788	1000 pF, 50 V, CER	70-138255
C724	0.022 uF, 50 V, CER	70-138162	C789 A	15 pF, 50 V, CER	70-138205
C725	4700 pF, 50 V, CER	70-138183	C789 B	15 pF, 50 V, CER	70-138205
C726	4700 pF, 50 V, CER	70-138183	C789 C	36 pF, 50 V, CER	70-138233

TR-053 BOARD (CONTINUED)

REF NO.	DESCRIPTION	PART NO.	REF NO.	DESCRIPTION	PART NO.
CAPACITORS (CONTINUED)			FILTERS		
C792 A	56 pF, 50 V, CER	70-138254	FL241	10F12B	70-179100
C792 B	47 pF, 50 V, CER	70-138185	FL242	10F12B	70-179100
C792 C	47 pF, 50 V, CER	70-138185	FL243	CFU455G2	70-179083
C801	39 pF, 50 V, CER	70-138233	FL244	CFU456F2	70-179078
C802	100 pF, 50 V, CER	70-138175	FL801	TPA 10.7 MA3	70-179101
C803	7 pF, 50 V, CER	70-138181			
C804	100 pF, 50 V, CER	70-138175			
C805	10 pF, 50 V, CER	70-138187			
C806	100 pF, 50 V, CER	70-138175			
C807	10 pF, 50 V, CER	70-138187	IC241	MC3381	70-076216
C808	100 pF, 50 V, CER	70-138175	IC401	AN8541	70-076253
C809	0.1 uF, 25 V, CER	70-138327	IC402	HA17805W	70-076567
C810	10 pF, 50 V, CER	70-138187	IC404	MC144111P	70-076568
C811	0.1 uF, 25 V, CER	70-138327	IC405	BA726F	70-076569
C813	220 pF, 50 V, CER	70-138176	IC406	TDA7240AV	70-076570
C814	4 pF, 50 V, CER	70-138179	IC408	AN5262	70-076571
C815	0.047 uF, 18 V, CER	70-138409	IC409	AN5262	70-076571
C816	0.047 uF, 18 V, CER	70-138409	IC411	MPC4741G2	70-076628
C818	15 pF, 50 V, CER	70-138205	IC412	AFL24F3120A14	70-076629
C819	0.022 uF, 50 V, CER	70-138162	IC771	MB1504PF-G-BND-TF	70-076568
C820	0.047 uF, 18 V, CER	70-138409	IC772	BU4068BF-T1	70-076573
C821	33 pF, 50 V, CER	70-138188	IC801	M1350F	70-076627
C822	0.022 uF, 50 V, CER	70-138162	IC901	M37450M4-273SP	70-076574
C823	0.047 uF, 18 V, CER	70-138409	IC902	MN1260R	70-076575
C824	0.01 uF, 50 V, CER	70-138270	IC903	M6M80021L	70-076576
C825	470 pF, 50 V, CER	70-138404			
C826	0.1 uF, 50 V, CER	70-138327			
C827	470 pF, 50 V, CER	70-138404			
C828	10 uF, 16 V, TA, ELYC	70-135165			
C829	18 pF, 50 V, CER	70-138206	J401	IL-S-14P-S2T2-EF	70-159558
C830	1000 pF, 50 V, CER	70-138255	J402	PS-10PE-D4T1-B1	70-159428
C831	0.047 uF, 50 V, CER	70-138409	J403	53029-0610	70-159559
C832	470 pF, 50 V, CER	70-138404	J404	IL-Y-4P-S15T2-EF	70-159560
C833	1000 pF, 50 V, CER	70-138255	J407	IL-Y-12P-S15T2-EF	70-159561
C834	4700 pF, 50 V, CER	70-138183	J408	IL-Y-13P-S15T2-EF	70-159562
C835	10 uF, 18 V, CER	70-135165	J409	JM6LS-10BAT	70-159563
C836	4700 pF, 50 V, CER	70-138163	J410	IL-Y-10P-S15T2-EF	70-159564
C837	0.1 uF, 25 V, CER	70-138327	J411	IL-S-15P-S2T2-EF	70-159425
C838	0.047 uF, 18 V, CER	70-138409	J413	EMC90552M	70-159093
C842	0.1 uF, 25 V, CER	70-138327	J414	IL-G-2P-S3T2-E	70-159565
C843	0.1 uF, 25 V, CER	70-138327	J420	IL-Y-4P-S15T2-EF	70-159560
C921	0.022 uF, 50 V, CER	70-138162	J511	JACK V	70-159089
C923	1000 pF, 50 V, CER	70-138255	J513	JACK V	70-159089
C925	0.01 uF, 50 V, CER	70-138270	J514	IL-D-3P-S2T2-EF	70-159254
C926	1000 pF, 50 V, CER	70-138255			
C927	1000 pF, 50 V, CER	70-138255			
C928	1000 pF, 50 V, CER	70-138255			
C929	22 pF, 50 V, CER	70-138171	JP1	0 OHM, 1/10 W, MET	70-144106
C930	47 pF, 50 V, CER	70-138185	JP2	0 OHM, 1/10 W, MET	70-144106
C931	10 uF, 16 V, AL, ELYC	70-138191	JP3	0 OHM, 1/10 W, MET	70-144106
C932	10 uF, 16 V, AL, ELYC	70-138191	JP6	0 OHM, 1/10 W, MET	70-144106
C933	1000 pF, 50 V, CER	70-138255	JP7	0 OHM, 1/10 W, MET	70-144106
C935	0.022 uF, 50 V, CER	70-138162	JP8	0 OHM, 1/10 W, MET	70-144106
C936	0.01 uF, 50 V, CER	70-138270	JP9	0 OHM, 1/10 W, MET	70-144106
			JP11	0 OHM, 1/10 W, MET	70-144106
DIODES			JUMPERS		
D101	KV1430TR01-34 (F3)	70-085312			
D102	KV1430TR01-34 (F3)	70-085312			
D201	DCC010	70-085313			
D202	ND487C2-3R	70-085228			
D241	DCA010-TA	70-085250			
D242	MA3088-M TW	70-085273			
D243	HSM88S	70-085154			
D244	DCA010-TA	70-085250			
D401	IMN10	70-085336			
D701	DCA010-TA	70-085250			
D702	DCA010-TA	70-085250			
D711	SVC341L	70-085352			
D713	MA704A	70-085247			
D731	SVC341L	70-085352			
D733	MA704A	70-085247			
D734	1SV166	70-085159			
D735	1SV166	70-085159			
D771	DCB010-TA	70-085245			
D901	DCC010	70-085513			
D901	DCB010-TA	70-085245			
D902	DCA010	70-085250			
D903	HZM5B	70-085253			
D904	DCA010	70-085250			
D905	DWA010-TF	70-085246			
			COILS		
			L101	42L-080	70-080482
			L132	LQH3N1R0M02M00-100	70-080535
			L133	LQN2AR22	70-080483
			L134	LQN2AR22	70-080483
			L201	L-1S7-M1 9.5T	70-080536
			L202	L-1S7-M1 9.5T	70-080536
			L203	L-1S7-M1 9.5T	70-080536
			L204	L-1S7-M1 9.5T	70-080536
			L205	L-1S7-M1 9.5T	70-080536
			L208	L-1S7-M1 9.5T	70-080536
			L207	L-1S7-M1 9.5T	70-080536
			L208	L-1S7-M1 9.5T	70-080536
			L209	LQH3N R36M	70-080537
			L210	ELESN470KA	70-080544
			L211	DBM	70-080407
			L212	DBM	70-080407
			L231	LQH3N1R0M02M00	70-080535
			L232	LQN2AR22K	70-080483
			L233	LQN2AR22K	70-080483
			L241	LQH3NR36	70-080537
			L242	LQH3N3P3	70-080538
			L243	LQH3N3P3	70-080538
			L244	LQH3N470	70-080538

TR-053 BOARD (CONTINUED)

REF NO.	DESCRIPTION	PART NO.	REF NO.	DESCRIPTION	PART NO.
COILS (CONTINUED)			TRANSISTORS (CONTINUED)		
L245	42L084	70-090540	Q711	3SK151GR	70-080303
L248	ELESN220KA	70-090541	Q712	2SC2351-T2B R3	70-080218
L247	24L129	70-090542	Q731	3SK151GR-TE85L	70-080303
L248	LQH3N8F8	70-090543	Q732	2SC2351-T2V R3	70-080218
L249	ELESN470KA	70-090544	Q733	2SC2351-T2V R3	70-080218
L250	41L001	70-090423	Q734	2SC2351-T2V R3	70-080218
L251	ELESN102KA	70-090474	Q771	IMD3-T1	70-080297
L252	ELESN47KA	70-090544	Q772	IMH1-T1	70-080298
L253	ELESN331KA	70-090478	Q773	2SC2482C	70-080288
L254	ELESN331KA	70-090478	Q774	2SA1122C	70-080182
L255	ELESN47KA	70-090544	Q775	2SA1121C	70-080339
L256	ELESN47KA	70-090544	Q776	2SC2482LC	70-080294
L401	1.0 MH	70-178057	Q778	IMH1	70-080298
L402	ELESN4.7KA	70-090488	Q801	2SK508K52	70-080324
L513	BL01RN-A62B1	70-090580	Q802	2SK508K52	70-080324
L514	BL01RN-A62B1	70-090580	Q803	3SK151GR	70-080303
L515	BL01RN-A62B1	70-090580	Q804	2SC2482C	70-080288
L517	BL01RN-1-A62	70-090483	Q805	2SA1121C	70-080339
L520	BL01RN-A62B1	70-090580	Q806	2SA1121C	70-080339
L521	ELESN 1F0	70-090480	Q807	2SC2482	70-080180
L525	BL01RN-A62	70-090482	Q808	2SA1121C	70-080339
L526	BL01RN-A62	70-090482	Q809	2SSA1121C	70-080339
L527	BL01RN-A62	70-090482	Q810	2SA1121C	70-080339
L528	BL01RN-A62	70-090482	Q811	2SC2482C	70-080180
L530	BL01RN-A62	70-090482	Q812	DTC124EK	70-080300
L711	LQH3N100K02M00-100	70-090545	RESISTORS		
L712	LQH3N100K02M00-100	70-090545	R101	47 KOHM, 1/10 W, MET	70-145145
L713 A	L-1S7-M1 7.5 T	70-090547	R102	47 KOHM, 1/10 W, MET	70-145145
L713 B	L-1S7-M1 7.5 T	70-090547	R103	47 KOHM, 1/10 W, MET	70-145145
L713 C	L-1S7-M1 6.5 T	70-090548	R104	47 KOHM, 1/10 W, MET	70-145145
L714	LQH3N100K02M00-100	70-090545	R106	22 KOHM, 1/10 W, MET	70-144121
L715	LQH3N100K02M00-100	70-090545	R107	1 KOHM, 1/4 W, MET	70-144268
L716	LQH3N100K02M00-100	70-090535	R108	10 KOHM, 1/10 W, MET	70-144120
L718	LQN2AR10K	70-090548	R109	4.7 KOHM, 1/10 W, MET	70-144123
L719	LQN2AR10K	70-090548	R110	2.2 KOHM, 1/10 W, MET	70-144113
L720	LQN2AR10K	70-090548	R111	1.5 KOHM, 1/10 W, MET	70-144134
L721	LQN2AR10K	70-090548	R112	10 KOHM, 1/10 W, MET	70-144120
L731	LQH3N100K02M00-100	70-090545	R113	4.7 KOHM, 1/10 W, MET	70-144123
L732	LQH3N100K02M00-100	70-090545	R114	1 KOHM, 1/10 W, MET	70-144125
L733 A	L-1S7-M1 10.5T	70-090551	R115	100 OHM, 1/10 W, MET	70-145146
L733 B	L-1S7-M1 9.5 T	70-090550	R116	100 OHM, 1/10 W, MET	70-145146
L733 C	L-1S7-M1 8.5T	70-090549	R117	220 OHM, 1/10 W, MET	70-144194
L734	LQH3N100K02M00-100	70-090545	R118	10 KOHM, 1/10 W, MET	70-144120
L735	LQH3N100K02M00-100	70-090545	R119	100 KOHM, 1/10 W, MET	70-145146
L736	LQH3N100K02M00-100	70-090545	R120	100 KOHM, 1/10 W, MET	70-145146
L771	LQN2A47NM	70-090484	R123	220 KOHM, 1/10 W, MET	70-145131
L801	42L084	70-090540	R124	47 KOHM, 1/10 W, MET	70-145122
L802	42L084	70-090540	R125	47 KOHM, 1/10 W, MET	70-145122
L803	42L084	70-090540	R126	15 KOHM, 1/10 W, MET	70-144119
L804	42L084	70-090540	R127	4.7 KOHM, 1/10 W, MET	70-144120
L805	LQH3N1F0	70-090535	R128	470 OHM, 1/10 W, MET	70-144152
L808	LQH3N4R7	70-090513	R129	680 OHM, 1/10 W, MET	70-144123
L807	LQH3N8F8	70-090543	R130	18 KOHM, 1/10 W, MET	70-144195
L808	ELESN102K	70-090474	R131	10 OHM, 1/10 W, MET	70-144115
T1	17005	70-090399	R132	470 OHM, 1/10 W, MET	70-144152
TRANSISTORS			R133	10 KOHM, 1/10 W, MET	70-144120
Q101	2SC2620B-TR (QB)	70-080181	R135	100 OHM, 1/10 W, MET	70-145146
Q102	2SC2482C-TR (LC)	70-080288	R136	88 OHM, 1/10 W, MET	70-144114
Q103	2SC2482C-TR (LC)	70-080288	R137	100 OHM, 1/10 W, MET	70-145146
Q131	2SC3357-T2	70-080375	R201 A	47 OHM, 1/10 W, MET	70-145130
Q201	2SC3356	70-080192	R201 B	33 OHM, 1/10 W, MET	70-140320
Q203	2SC3357	70-080375	R201 C	47 OHM, 1/10 W, MET	70-145130
Q241	2SK125	70-080089	R202	18 KOHM, 1/10 W, MET	70-144171
Q242	2SK360E	70-080362	R203	560 OHM, 1/10 W, MET	70-144130
Q243	2SC2482	70-080294	R204	22 KOHM, 1/10 W, MET	70-144121
Q244	2SC2482	70-080294	R205	5.6 KOHM, 1/10 W, MET	70-144168
Q401	IMX2-T108 (X2)	70-080363	R206	22 OHM, 1/10 W, MET	70-144180
Q403	IMX2-T108 (X2)	70-080363	R207 B	470 OHM, 1/10 W, MET	70-144152
Q406	2SC2482	70-080294	R207 C	270 OHM, 1/10 W, MET	70-144118
Q408	2SK508	70-080191	R208 B	10 OHM, 1/10 W, MET	70-144115
Q409	2SC2482	70-080294	R208 C	0 OHM, 1/10 W, MET	70-144108
Q410	2SC2482	70-080294	R208 B	470 OHM, 1/10 W, MET	70-144152
Q504	2SB1065Q	70-080367	R208 C	270 OHM, 1/10 W, MET	70-144116
Q701	2SC2482C	70-080288	R231	470 OHM, 1/10 W, MET	70-144152
Q702	IMB3-T110 (B3)	70-080384	R232	10 KOHM, 1/10 W, MET	70-144120
Q703	IMH1-T1	70-080298	R234	22 OHM, 1/10 W, MET	70-144180
Q704	2SB798	70-080184	R235	270 OHM, 1/10 W, MET	70-144118
Q705	DTC124EK	70-080274	R236	18 OHM, 1/10 W, MET	70-144171

PARTS

70-0371/0375

TR-053 BOARD (CONTINUED)

REF NO.	DESCRIPTION	PART NO.	REF NO.	DESCRIPTION	PART NO.
RESISTORS (CONTINUED)			RESISTORS (CONTINUED)		
R237	270 OHM, 1/10 W, MET	70-144118	R524	1 KOHM, 1/10 W, MET	70-144125
R241	47 OHM, 1/10 W, MET	70-145130	R701	220 OHM, 1/10 W, MET	70-144194
R242	150 OHM, 1/10 W, MET	70-140321	R702	47 KOHM, 1/10 W, MET	70-145145
R247	82 KOHM, 1/10 W, MET	70-144173	R704	47 KOHM, 1/10 W, MET	70-145145
R248	22 KOHM, 1/10 W, MET	70-144121	R705	47 KOHM, 1/10 W, MET	70-145145
R249	150 OHM, 1/10 W, MET	70-140321	R706	47 KOHM, 1/10 W, MET	70-145145
R250	12 KOHM, 1/10 W, MET	70-144111	R707	220 OHM, 1/10 W, MET	70-144194
R251	330 OHM, 1/10 W, MET	70-144184	R708	4.7 KOHM, 1/10 W, MET	70-144123
R252	3.9 KOHM, 1/10 W, MET	70-145132	R711	47 OHM, 1/10 W, MET	70-145130
R254	0 OHM, 1/10 W, MET	70-144106	R712	8.8 KOHM, 1/10 W, MET	70-144158
R255	1.2 KOHM, 1/10 W, MET	70-144187	R713	10 KOHM, 1/10 W, MET	70-144120
R258	82 KOHM, 1/10 W, MET	70-144173	R714	22 KOHM, 1/10 W, MET	70-144121
R257	47 KOHM, 1/10 W, MET	70-145145	R715	22 KOHM, 1/10 W, MET	70-144121
R258	470 KOHM, 1/10 W, MET	70-144188	R716	2.2 KOHM, 1/10 W, MET	70-144158
R259	2.2 KOHM, 1/10 W, MET	70-144113	R717	8.8 KOHM, 1/10 W, MET	70-140321
R260	5.8 KOHM, 1/10 W, MET	70-144188	R718	150 OHM, 1/10 W, MET	70-144118
R261	3.3 KOHM, 1/10 W, MET	70-144118	R719	3.3 KOHM, 1/10 W, MET	70-144118
R262	82 KOHM, 1/10 W, MET	70-144173	R720	1 KOHM, 1/10 W, MET	70-144125
R263	10 KOHM, 1/10 W, MET	70-144120	R721	100 OHM, 1/10 W, MET	70-145148
R264	27 KOHM, 1/10 W, MET	70-144183	R721	47 OHM, 1/10 W, MET	70-145130
R265	15 KOHM, 1/10 W, MET	70-144122	R722	47 OHM, 1/10 W, MET	70-145130
R268	47 KOHM, 1/10 W, MET	70-144231	R731	47 OHM, 1/10 W, MET	70-145130
R401	270 OHM, 1/4 W, MET	70-144183	R732	6.8 KOHM, 1/10 W, MET	70-144158
R402	22 KOHM, 1/10 W, MET	70-144121	R733	10 KOHM, 1/10 W, MET	70-144120
R404	33 KOHM, 1/10 W, MET	70-144112	R734	22 KOHM, 1/10 W, MET	70-144121
R405	1 KOHM, 1/10 W, MET	70-144125	R735	22 KOHM, 1/10 W, MET	70-144121
R406	100 KOHM, 1/10 W, MET	70-144321	R736	1 KOHM, 1/10 W, MET	70-144125
R407	100 KOHM, 1/10 W, MET	70-144321	R737	150 OHM, 1/10 W, MET	70-140321
R408	100 KOHM, 1/10 W, MET	70-144321	R738	3.3 KOHM, 1/10 W, MET	70-144118
R409	100 KOHM, 1/10 W, MET	70-144321	R739	1 KOHM, 1/10 W, MET	70-144125
R410	33 KOHM, 1/10 W, MET	70-144112	R740	100 OHM, 1/10 W, MET	70-145148
R411	22 KOHM, 1/10 W, MET	70-144121	R741	47 OHM, 1/10 W, MET	70-145130
R412	10 KOHM, 1/10 W, MET	70-144120	R742	47 OHM, 1/10 W, MET	70-145130
R413	1 KOHM, 1/10 W, MET	70-144125	R751	47 KOHM, 1/10 W, MET	70-145145
R414	15 KOHM, 1/10 W, MET	70-144122	R752	47 KOHM, 1/10 W, MET	70-145145
R415	150 KOHM, 1/10 W, MET	70-144129	R754	3.3 KOHM, 1/10 W, MET	70-144118
R416	68 KOHM, 1/10 W, MET	70-144119	R755	1 KOHM, 1/10 W, MET	70-144125
R417	4.7 KOHM, 1/10 W, MET	70-144123	R756	100 OHM, 1/10 W, MET	70-145148
R418	100 KOHM, 1/10 W, MET	70-145148	R757	47 OHM, 1/10 W, MET	70-145130
R419	330 KOHM, 1/10 W, MET	70-140318	R758	1 KOHM, 1/10 W, MET	70-144125
R421	150 KOHM, 1/10 W, MET	70-144129	R759	3.3 KOHM, 1/10 W, MET	70-144118
R422	22 KOHM, 1/10 W, MET	70-144121	R760	100 OHM, 1/10 W, MET	70-145148
R423	100 KOHM, 1/10 W, MET	70-144321	R781	0 OHM, 1/10 W, MET	70-144106
R424	47 KOHM, 1/10 W, MET	70-145145	R782	0 OHM, 1/10 W, MET	70-144106
R425	12 KOHM, 1/10 W, MET	70-144111	R770	47 KOHM, 1/10 W, MET	70-145145
R426	1 KOHM, 1/10 W, MET	70-144125	R771	100 KOHM, 1/10 W, MET	70-144321
R427	4.7 KOHM, 1/10 W, MET	70-144123	R772	22 OHM, 1/10 W, MET	70-144180
R428	680 OHM, 1/10 W, MET	70-144157	R773	100 KOHM, 1/10 W, MET	70-144321
R430	1 KOHM, 1/10 W, MET	70-144125	R774	1 KOHM, 1/10 W, MET	70-144125
R431	1.5 KOHM, 1/10 W, MET	70-144134	R775	0 OHM, 1/10 W, MET	70-144108
R434	15 KOHM, 1/10 W, MET	70-144122	R776	47 KOHM, 1/10 W, MET	70-145145
R435	10 KOHM, 1/10 W, MET	70-144120	R777	4.7 KOHM, 1/10 W, MET	70-144123
R436	22 KOHM, 1/10 W, MET	70-144121	R778	10 KOHM, 1/10 W, MET	70-144120
R437	10 KOHM, 1/10 W, MET	70-144120	R779	22 KOHM, 1/10 W, MET	70-144121
R438	1 KOHM, 1/10 W, MET	70-144125	R780	0 OHM, 1/10 W, MET	70-144108
R440	150 KOHM, 1/10 W, MET	70-144267	R782	4.7 KOHM, 1/10 W, MET	70-144123
R441	100 KOHM, 1/10 W, MET	70-144322	R783	47 KOHM, 1/10 W, MET	70-145145
R442	1 KOHM, 1/10 W, MET	70-144269	R784	47 KOHM, 1/10 W, MET	70-145145
R443	39 KOHM, 1/10 W, MET	70-144280	R785	100 KOHM, 1/10 W, MET	70-144321
R444	82 KOHM, 1/10 W, MET	70-144291	R786	22 KOHM, 1/10 W, MET	70-144121
R445	100 KOHM, 1/10 W, MET	70-144119	R787	100 OHM, 1/10 W, MET	70-145148
R446	2.2 KOHM, 1/10 W, MET	70-144113	R788	22 OHM, 1/10 W, MET	70-144180
R447	4.7 KOHM, 1/10 W, MET	70-144123	R789	4.7 KOHM, 1/10 W, MET	70-144123
R448	10 KOHM, 1/10 W, MET	70-144120	R790	1 KOHM, 1/10 W, MET	70-144125
R452	330 OHM, 1/8 W, MET	70-144085	R791	1 KOHM, 1/10 W, MET	70-144125
R453	100 OHM, 1/10 W, MET	70-144115	R792	4.7 KOHM, 1/10 W, MET	70-144123
R455	10 KOHM, 1/10 W, MET	70-144120	R793	47 KOHM, 1/10 W, MET	70-145145
R456	10 KOHM, 1/10 W, MET	70-144120	R794	1.5 KOHM, 1/10 W, MET	70-144134
R457	2.2 KOHM, 1/10 W, MET	70-144113	R795	47 KOHM, 1/10 W, MET	70-145145
R458	330 OHM, 1/10 W, MET	70-144184	R798	22 KOHM, 1/10 W, MET	70-144121
R461	1 KOHM, 1/10 W, MET	70-144125	R797	5.8 KOHM, 1/10 W, MET	70-144188
R462	3.3 KOHM, 1/10 W, MET	70-144118	R798	1 KOHM, 1/10 W, MET	70-144125
R463	560 OHM, 1/10 W, MET	70-144130	R799	2.7 KOHM, 1/10 W, MET	70-144159
R464	2.7 KOHM, 1/10 W, MET	70-144159	R801	4.7 KOHM, 1/10 W, MET	70-144123
R465	100 KOHM, 1/10 W, MET	70-144321	R802	3.3 KOHM, 1/10 W, MET	70-144118
R466	47 KOHM, 1/10 W, MET	70-145145	R803	10 KOHM, 1/10 W, MET	70-144120
R467	47 KOHM, 1/10 W, MET	70-145145	R804	10 KOHM, 1/10 W, MET	70-144120
R470	22 KOHM, 1/10 W, MET	70-144121	R805	3.3 KOHM, 1/10 W, MET	70-144118
R471	0 OHM, 1/10 W, MET	70-144106	R806	4.7 KOHM, 1/10 W, MET	70-144123
R472	22 KOHM, 1/10 W, MET	70-144121	R807	580 OHM, 1/10 W, MET	70-144130
			R808	4.7 KOHM, 1/10 W, MET	70-144123

PARTS

70-0371/0375

PA-0502 BOARD

70-0371/0375 A BAND USE "A"					
70-0371/0375 B BAND USE "B"					
70-0371/0375 C BAND USE "C"					
REF NO.	DESCRIPTION	PART NO.	REF NO.	DESCRIPTION	PART NO.
CAPACITORS			CAPACITORS (CONTINUED)		
C502	0.01 uF, 50 V, CERAMIC	70-138270	C582	0.01 uF, 50 V, CERAMIC	70-138270
C504	0.01 uF, 50 V, CERAMIC	70-138270	C587	1000 pF, 50 V, CERAMIC	70-138255
C505	47 uF, 25 V, AL, ELYC	70-135055	C589	1000 pF, 50 V, CERAMIC	70-138255
C508	1000 pF, 50 V, CERAMIC	70-138255	C591	1000 pF, 50 V, CERAMIC	70-138255
C507	0.01 uF, 50 V, CERAMIC	70-138270	C592	0.01 uF, 50 V, CERAMIC	70-138270
C506	0.01 uF, 50 V, CERAMIC	70-138270	C593 B	220 pF, 50 V, CERAMIC	70-138349
C509	47 uF, 25 V, AL, ELYC	70-135055	C593 C	220 pF, 50 V, CERAMIC	70-138349
C510	0.1 uF, 50 V, CERAMIC	70-138249	C594	0.01 uF, 50 V, CERAMIC	70-131297
C511	0.01 uF, 50 V, CERAMIC	70-138270	C595	1000 pF, 100 V, CERAMIC	70-138239
C512 A	100 pF, 50 V, CERAMIC	70-138175	C596 B	91 pF, 500 V, MICA	70-138110
C512 B	150 pF, 50 V, CERAMIC	70-138231	C596 C	96 pF, 500 V, MICA	70-138141
C512 C	150 pF, 50 V, CERAMIC	70-138231	C597 B	91 pF, 500 V, MICA	70-138110
C513 A	100 pF, 50 V, CERAMIC	70-138175	C597 C	96 pF, 500 V, MICA	70-138141
C513 B	82 pF, 50 V, CERAMIC	70-138250	C598 A	56 pF, 500 V, CERAMIC	70-138265
C513 C	82 pF, 50 V, CERAMIC	70-138250	C598 B	47 pF, 500 V, CERAMIC	70-138268
C517	0.1 uF, 50 V, CERAMIC	70-138249	C598 C	39 pF, 500 V, CERAMIC	70-138266
C518	15 uF, 25 V, AL, ELYC	70-135154			
C521	1000 pF, 50 V, CERAMIC	70-138255		DIODES	
C524 A	470 pF, 50 V, CERAMIC	70-138195	D501	DWA010	70-085246
C524 B	220 pF, 50 V, CERAMIC	70-138349	D502	HSM68S	70-085154
C524 C	220 pF, 50 V, CERAMIC	70-138349	D503	DCA010	70-085250
C525 B	220 pF, 50 V, CERAMIC	70-138349	D504	RM4AM LF-JB	70-085269
C525 C	220 pF, 50 V, CERAMIC	70-138349			
C528	1000 pF, 50 V, CERAMIC	70-138255		JACKS	
C529	0.01 uF, 50 V, CERAMIC	70-138270	J501	JACK V	70-156089
C530	0.1 uF, 50 V, CERAMIC	70-138249	J502	MR-D62504E-01	70-156427
C531	0.22 uF, 50 V, PLASTIC	70-138180	J503	JACK V	70-156089
C532 A	1000 pF, 100 V, CERAMIC	70-138239			
C532 B	470 pF, 100 V, CERAMIC	70-138239		COILS	
C532 C	1000 pF, 100 V, CERAMIC	70-138239	L501 A	ELE-Y R22MA	70-090374
C533	1000 pF, 100 V, CERAMIC	70-138239	L501 B	ZD.8C5D 3.5T	70-090099
C534	0.01 uF, 50 V, CERAMIC	70-138270	L501 C	ZD.8C5D 3.5T	70-090099
C535	0.1 uF, 50 V, CERAMIC	70-138249	L502 A	ELE-Y R47MA	70-090200
C536	15 uF, 25 V, AL, ELYC	70-135154	L502 B	ZD.8C5D 3.5T	70-090099
C537 A	22 pF, 500 V, MICA	70-138107	L502 C	ZD.8C5D 3.5T	70-090099
C538 C	220 pF, 100 V, CERAMIC	70-138261	L503 A	ZD.8C5D 1.5T	70-090097
C541	0.01 uF, 50 V, CERAMIC	70-131297	L503 B	ZD.8C5D 2.5T	70-090098
C542	330 pF, 100 V, CERAMIC	70-138320	L503 C	ZD.8C5D 2.5T	70-090098
C543 A	680 pF, 300 V, MICA	70-137103	L504	BL02RN1-R62	70-090122
C543 B	680 pF, 300 V, MICA	70-137103	L505 A	ZD.8C5D 1.5T	70-090097
C543 C	470 pF, 300 V, MICA	70-137104	L505 B	ZD.8C5D 1.5T	70-090097
C545 A	470 pF, 300 V, MICA	70-137104	L505 C	ZD.8C3D 0.5T	70-090184
C545 B	330 pF, 300 V, MICA	70-137105	L506	BL02RN1-R62	70-090122
C545 C	330 pF, 300 V, MICA	70-137105	L507	ZD.8C5D 4.5T	70-090129
C546	470 pF, 100 V, CERAMIC	70-138239	L508	BL02RN1-R62	70-090122
C550	0.1 uF, 50 V, CERAMIC	70-138249	L509 A	Z1.8C5D 3.5T	70-090099
C551	47 uF, 25 V, AL, ELYC	70-135055	L509 B	Z1.8C5D 3.5T	70-090099
C552	1000 pF, 100 V, CERAMIC	70-138239	L509 C	Z1.8C5D 6.5T	70-090131
C554	0.1 uF, 50 V, CERAMIC	70-138249	L512 A	Z1.0C5D 6.5T	70-090527
C555	15 uF, 25 V, AL, ELYC	70-135154	L512 B	Z1.0C5D 5.5T	70-090528
C556 A	4 pF, 500 V, CERAMIC	70-138328	L512 C	Z1.0C5D 4.5T	70-090591
C556 B	4 pF, 500 V, CERAMIC	70-138328	L516	BL02RN1-R62	70-090122
C556 C	3 pF, 500 V, CERAMIC	70-138311	L521 A	Z1.0C5D 9.5T	70-090529
C557	150 pF, 100 V, CERAMIC	70-138258	L521 B	Z1.0C5D 7.5T	70-090530
C563 A	56 pF, 500 V, CERAMIC	70-138265	L521 C	Z1.0C5D 6.5T	70-090527
C563 B	56 pF, 500 V, CERAMIC	70-138265	L522 A	Z1.0C5D 10.5T	70-090531
C563 C	47 pF, 500 V, CERAMIC	70-138268	L522 B	Z1.0C5D 6.5T	70-090532
C565 A	120 pF, 500 V, CERAMIC	70-138306	L522 C	Z1.0C5D 7.5T	70-090530
C565 B	100 pF, 500 V, CERAMIC	70-138264	T1	17L006	70-090524
C565 C	82 pF, 500 V, CERAMIC	70-138259	T2	17L007	70-090525
C566 A	27 pF, 500 V, CERAMIC	70-138305	T3	17L006	70-090399
C566 B	33 pF, 500 V, CERAMIC	70-138262			
C566 C	27 pF, 500 V, CERAMIC	70-138305		TRANSISTORS	
C567 A	150 pF, 500 V, CERAMIC	70-138256	Q501	29C2538	70-090108
C567 B	120 pF, 500 V, CERAMIC	70-138306	Q502	29C1971	70-090054
C567 C	100 pF, 500 V, CERAMIC	70-138264	Q503	29C2630	70-090091
C569 A	9 pF, 500 V, CERAMIC	70-138131	Q505	MRF492	70-085342
C569 B	7 pF, 500 V, CERAMIC	70-138310	Q507	MRF492	70-085342
C569 C	6 pF, 500 V, CERAMIC	70-138329	Q509	29C2482	70-090294
C570 A	82 pF, 500 V, CERAMIC	70-138259			
C570 B	66 pF, 500 V, CERAMIC	70-138268			
C570 C	56 pF, 500 V, CERAMIC	70-138265			
C581	0.01 uF, 50 V, CERAMIC	70-138270			

PA-0502 BOARD (CONTINUED)

REF NO.	DESCRIPTION	PART NO.	REF NO.	DESCRIPTION	PART NO.
RESISTORS			RESISTORS		
R501	220 OHM, 1/10 W, METAL	70-144184	R518	33 OHM, 1/10 W, METAL	70-140320
R502	2.2 KOHM, 1/10 W, METAL	70-144113	R517	33 OHM, 1/10 W, METAL	70-140320
R503	3.3 OHM, 1/10 W, METAL	70-144198	R518	33 OHM, 1/10 W, METAL	70-140320
R504	33 OHM, 1 W, METAL	70-142028	R519	33 OHM, 1/10 W, METAL	70-140320
R505	33 OHM, 1 W, METAL	70-142028	R520	100 KOHM, 1/10 W, METAL	70-144321
R508 A	180 OHM, 1/10 W, METAL	70-144313	R521	100 KOHM, 1/10 W, METAL	70-144321
R508 B	180 OHM, 1/10 W, METAL	70-144313	R527	1.8 KOHM, 1/10 W, METAL	70-144154
R508 C	100 OHM, 1 W, METAL	70-144139	R528	470 OHM, 1/10 W, METAL	70-144152
R507 A	330 OHM, 1 W, METAL	70-144184	R529	4.7 KOHM, 1/10 W, METAL	70-144123
R510 A	10 OHM, 2 W, METAL	70-144300	R532	580 OHM, 1/10 W, METAL	70-144130
R510 B	10 OHM, 2 W, METAL	70-144300	MISCELLANEOUS		
R510 C	2.2 OHM, 3 W, METAL	70-144200	CA502	CORE, Q58RID 7.5 x 7 x 13	70-178075
R511	36 OHM, 1 W, METAL	70-144314	CA504	CABLE ASSEMBLY 1-350345-0	70-034319
R512	10 OHM, 1 W, METAL	70-144082	K501	CABLE ASSEMBLY IL-T-3P-IL-S-3S	70-178099
R513	10 OHM, 1 W, METAL	70-144082		RELAY CX-220P	70-105014
R514	36 OHM, 3 W, METAL	70-144314			
R515	36 OHM, 3 W, METAL	70-144314			

CONTROL HEAD

REF NO.	DESCRIPTION	PART NO.	REF NO.	DESCRIPTION	PART NO.
70-0371/0375 A BAND USE "A"			UD = Under-dash only		
70-0371/0375 B BAND USE "B"			TM = Trunk-mount only		
70-0371/0375 C BAND USE "C"					
CAPACITORS			RESISTORS		
C301	0.01 uF, 50 V, CER	70-138270	R313	33 KOHM, 1/10 W, MET	70-144112
C302	1000 pF, 50 V, CER	70-138170	R314	150 OHM, 1/8 W, MET	70-144011
C303	0.01 uF, 50 V, CER	70-138270	R318	150 OHM, 1/8 W, MET	70-144011
C304	1 uF, 50 V, AL ELYC	70-138194	R317	330 OHM, 1/8 W, MET	70-144184
C305	1000 pF, 50 V, CER	70-138170	VARIABLE RESISTORS		
C306	1000 pF, 50 V, CER	70-138170	RV301	K1214005L (10KB)	70-180025
C307 (UD)	470 uF, 25 V, AL, ELYC	70-135237	RV302	K1214105G (10KB)	70-180026
C331 TM	1000 pF, 45 V, CER	70-131397	SWITCHES		
CABLE ASSEMBLIES			S301	ESB-64803	70-183080
CA301	SMV 2d 15x21	70-034620	S302	ESB-64803	70-183080
CA302	SMV 2d 3x83	70-034621	S303	ESB-64803	70-183080
CA303-1	ILYB-15P-ILS 15S	70-034622	S304	ESB-64803	70-183080
CA303-2	ILYB-14P-ILS 14S	70-034623	S305	SRBU1CL-15MM	70-183084
CA304	ILG 2S-5307	70-034624	JACKS		
CA324 TM	1282R L=120	70-034630	J301	NS1504L	70-159100
DIODES			J304	IL-G-2P-S3T2-EF	70-159565
D301	LED LB 402	70-202066	J321 TM	D3431	70-159593
D302	SLM-245 LMW TE84L	70-085316	J322 TM	IL-S-15P-S2T2-EF	70-159425
D303	SLM-125MT TE84L	70-085317	J323 TM	IL-S-14P-S2T2-EF	70-159558
D304	SLM-125MT TE84L	70-085317	J324 TM	IL-S-14P-S2T2-EF	70-159558
D305	SLM-125MT TE84L	70-085317	J325 TM	IL-S-14P-S2T2-EF	70-159558
D306	SLM-125MT TE84L	70-085317	JUMPERS		
INTEGRATED CIRCUITS			JP301	0 OHM, 1/10 W, MET	70-144106
IC301	AN6987K	70-078577	JP302	0 OHM, 1/10 W, MET	70-144106
IC302	BU74HC174F-T1	70-078578	JP303	0 OHM, 1/10 W, MET	70-144106
TRANSISTORS			JP304	0 OHM, 1/10 W, MET	70-144106
Q301	2SA1121C-TR	70-080339	JP306	0 OHM, 1/10 W, MET	70-144106
Q302	IMH1-T1	70-080296	JP307	0 OHM, 1/10 W, MET	70-144106
Q303	IMH1-T1	70-080296	JP308	0 OHM, 1/10 W, MET	70-144106
RESISTORS			JP309	0 OHM, 1/10 W, MET	70-144106
R301	880 OHM, 1/10 W, MET	70-144157	JP310	0 OHM, 1/10 W, MET	70-144106
R303	270 OHM, 1/10 W, MET	70-144118	JP331 TM	0 OHM, 1/10 W, MET	70-144105
R304	270 OHM, 1/10 W, MET	70-144118	JP332 TM	0 OHM, 1/10 W, MET	70-144105
R305	270 OHM, 1/10 W, MET	70-144118	JP333 TM	0 OHM, 1/10 W, MET	70-144105
R306	270 OHM, 1/10 W, MET	70-144118	JP334 TM	0 OHM, 1/10 W, MET	70-144105
R308	270 OHM, 1/10 W, MET	70-144118	MISCELLANEOUS		
R308	330 KOHM, 1/10 W, MET	70-140318	CD301	PHOTO SENSOR P1201	70-085054
R309	47 KOHM, 1/10 W, MET	70-145145	SP301 UD	SPEAKER	70-080033
R310	47 KOHM, 1/10 W, MET	70-145145			
R311	47 KOHM, 1/10 W, MET	70-145145			
R312	220 KOHM, 1/10 W, MET	70-144131			



PARTS

70-0371/0375

Z-593 TRUNK-MOUNT INTERFACE BOARD

70-0375 A BAND		USE "A"	70-0375 B BAND		USE "B"	70-0375 C BAND		USE "C"
REF NO.	DESCRIPTION	PART NO.	REF NO.	DESCRIPTION	PART NO.			
CAPACITORS			CONNECTORS					
C311	0.01 uF, 50 V, CER	70-138270	J311	D3431	70-159592			
C312	0.01 uF, 50 V, CER	70-138270	JUMPERS					
C313	0.01 uF, 50 V, CER	70-138270	JP311	0 OHM, 1/10 W, MET	70-144108			
C314	0.01 uF, 50 V, CER	70-138270	JP312	0 OHM, 1/10 W, MET	70-144108			
C316	0.01 uF, 50 V, CER	70-138270	JP313	0 OHM, 1/10 W, MET	70-144108			
C317	0.01 uF, 50 V, CER	70-138270	JP316	0 OHM, 1/10 W, MET	70-144108			
C318	0.01 uF, 50 V, CER	70-138270	JP317	0 OHM, 1/10 W, MET	70-144108			
C319	0.01 uF, 50 V, CER	70-138270	JP318	0 OHM, 1/10 W, MET	70-144108			
C321	0.01 uF, 50 V, CER	70-138270	JP319	0 OHM, 1/10 W, MET	70-144108			
C322	0.01 uF, 50 V, CER	70-138270	JP321	0 OHM, 1/10 W, MET	70-144108			
C328	4.7 uF, 50 V, CER	70-138086	JP322	0 OHM, 1/10 W, MET	70-144108			
CABLE ASSEMBLIES			JP323	0 OHM, 1/10 W, MET	70-144108			
CA311	IL-YB-14P-IL-S-14S	70-034827	JP324	0 OHM, 1/10 W, MET	70-144108			
CA312	IL-3-2P-IL-G-2S	70-034828	SWITCHES					
CA313	ILJ2P-EMCHUM0201W	70-034825	K311	RELAY AGP8003	70-105022			
CA316	IL-YE-15P-IL-S-15S	70-034596						
DIODES								
D311	DCB010	70-085323						

70-2157 CTCSS FILTER BOARD

70-0371/0375 A BAND		USE "A"	70-0371/0375 B BAND		USE "B"	70-0371/0375 C BAND		USE "C"
REF NO.	DESCRIPTION	PART NO.	REF NO.	DESCRIPTION	PART NO.			
CAPACITORS			RESISTORS					
C1	6.3 uF, 10 V, AL, ELYC	70-135335	R1	10 KOHM, 1/10 W, MET	70-144120			
C2	880 pF, 50 V, CER	70-136252	R2	12 KOHM, 1/10 W, MET	70-144111			
C4	6.3 uF, 10 V, AL, ELYC	70-135335	R3	10 KOHM, 1/10 W, MET	70-144120			
C5	0.1 uF, 25 V, CER	70-136327	R4	100 KOHM, 1/10 W, MET	70-145128			
C6	6.3 uF, 10 V, AL, ELYC	70-135335	R5	100 KOHM, 1/10 W, MET	70-145128			
C7	1 uF, 50 V, CER	70-135257	R6	150 KOHM, 1/10 W, MET	70-144128			
C8	0.022 uF, 25 V, CER	70-136162	R7	120 KOHM, 1/10 W, MET	70-144310			
C9	1500 pF, 50 V, CER	70-136204	R8	1 KOHM, 1/10 W, MET	70-144125			
C10	1500 pF, 50 V, CER	70-136204	R10	27 KOHM, 1/10 W, MET	70-144163			
C50	0.01 uF, 50 V, CER	70-136270	R11	470 KOHM, 1/10 W, MET	70-144199			
C51	0.01 uF, 25 V, PLAS	70-137128	R12	2.2 KOHM, 1/10 W, MET	70-144113			
C52	0.01 uF, 25 V, PLAS	70-137128	R13	22 KOHM, 1/10 W, MET	70-144121			
C53	0.01 uF, 25 V, PLAS	70-137128	R14	3.3 KOHM, 1/10 W, MET	70-144118			
C54	0.01 uF, 25 V, PLAS	70-137128	R15	1 KOHM, 1/10 W, MET	70-144125			
C55	0.01 uF, 25 V, PLAS	70-137128	R16	1 KOHM, 1/10 W, MET	70-144125			
C56	0.01 uF, 25 V, PLAS	70-137128	R17	39 KOHM, 1/10 W, MET	70-144198			
C57	0.01 uF, 25 V, PLAS	70-137128	R18	22 KOHM, 1/10 W, MET	70-144121			
C58	0.01 uF, 25 V, PLAS	70-137128	R20	100 KOHM, 1/10 W, MET	70-145128			
C59	1 uF, 50 V, AL, ELYC	70-135257	R50	820 OHM, 1/10 W, MET	70-144185			
C80	0.01 uF, 50 V, CER	70-136270	R51	24 KOHM, 1/10 W, MET	70-144306			
C81	0.01 uF, 50 V, CER	70-136270	R52	0 OHM, 1/10 W, MET	70-144108			
C82	6.8 uF, 10 V, AL, ELYC	70-135335	R53	27 KOHM, 1/10 W, MET	70-144163			
INTEGRATED CIRCUITS			R54	4.3 KOHM, 1/10 W, MET	70-144307			
IC1	MF6CN-50	70-076611	R55	560 KOHM, 1/10 W, MET	70-144306			
IC2	BU4066BF	70-076573	R56	18 KOHM, 1/10 W, MET	70-144195			
IC50	BA10324F	70-076612	R57	56 KOHM, 1/10 W, MET	70-144199			
TRANSISTORS			R58	12 KOHM, 1/10 W, MET	70-144111			
Q1	2SC2462C	70-080268	R59	150 KOHM, 1/10 W, MET	70-144129			
Q2	2SC2462C	70-080268	R60	270 OHM, 1/10 W, MET	70-144116			
VARIABLE RESISTORS			R61	180 KOHM, 1/10 W, MET	70-144309			
RV1	50 KOHM	70-164114	R62	100 KOHM, 1/10 W, MET	70-145128			
			MISCELLANEOUS					
			P403	SCREW BIND HD M26 x 6	70-150169			
							CONNECTOR 5613-8CP8	70-159567

REPLACEMENT PARTS ORDERING

To speed delivery and avoid errors, always include the following information when ordering replacement parts:

1. Best identification of the parts.
 - A. MIDLAND part number, or
 - B. Model and Serial numbers of equipment in which the part is used, with
 - C. Part description, and
 - D. Schematic reference designator, and,
 - E. If necessary, return the old part as sample.
2. Specify quantity desired of each part.
3. Ship-to address (and billing address if different).

Mail or phone your order to:

MIDLAND INTERNATIONAL CORPORATION
1690 North Topping Avenue
Kansas City, Missouri 64120
(816) 241-8500





1690 NORTH TOPPING • KANSAS CITY • MISSOURI • 64120
(P.O. BOX 419903 • KANSAS CITY • MISSOURI • 64141)
TELEPHONE: (816) 241-8500 • FAX: (816) 245-1144

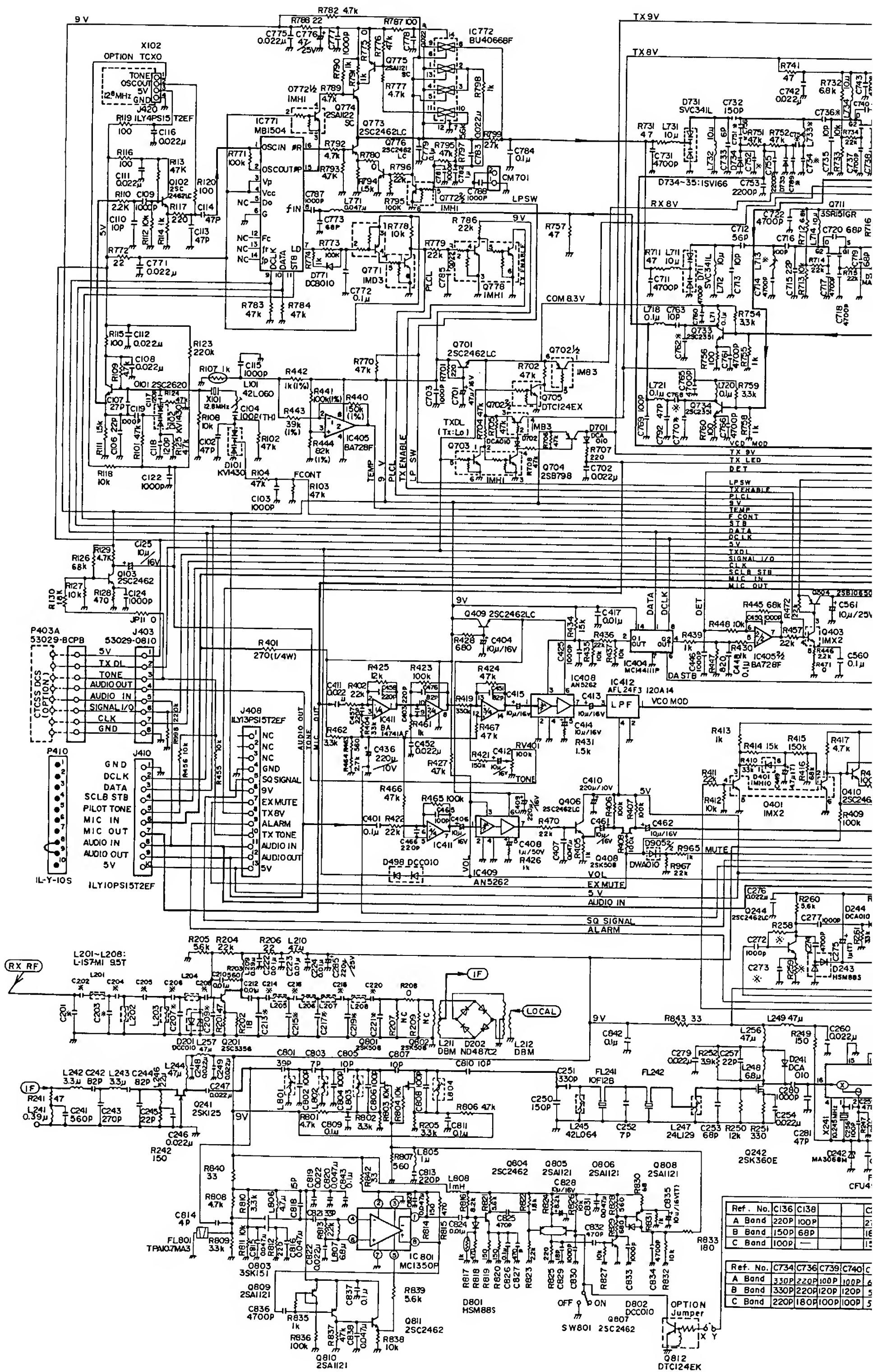

Ref. No.	C136	C138	C
A Band	220P	100P	2
B Band	150P	68P	1E
C Band	100P	—	1E

Ref. No.	C734	C736	C739	C740	C
A Band	330P	220P	100P	100P	6
B Band	330P	220P	120P	120P	5
C Band	220P	180P	100P	100P	5

OFF ON D802 OPTION
 SW801 25C2462 Jumper
 X Y
 D801 HSM885
 Q801 25C2462
 Q802 DCC010
 Q803 3SK151
 Q804 25C2462
 Q805 25A1121
 Q806 25A1121
 Q807 25C2462
 Q808 25A1121
 Q809 25A1121
 Q810 25A1121
 Q811 25C2462
 Q812 DTC124EK

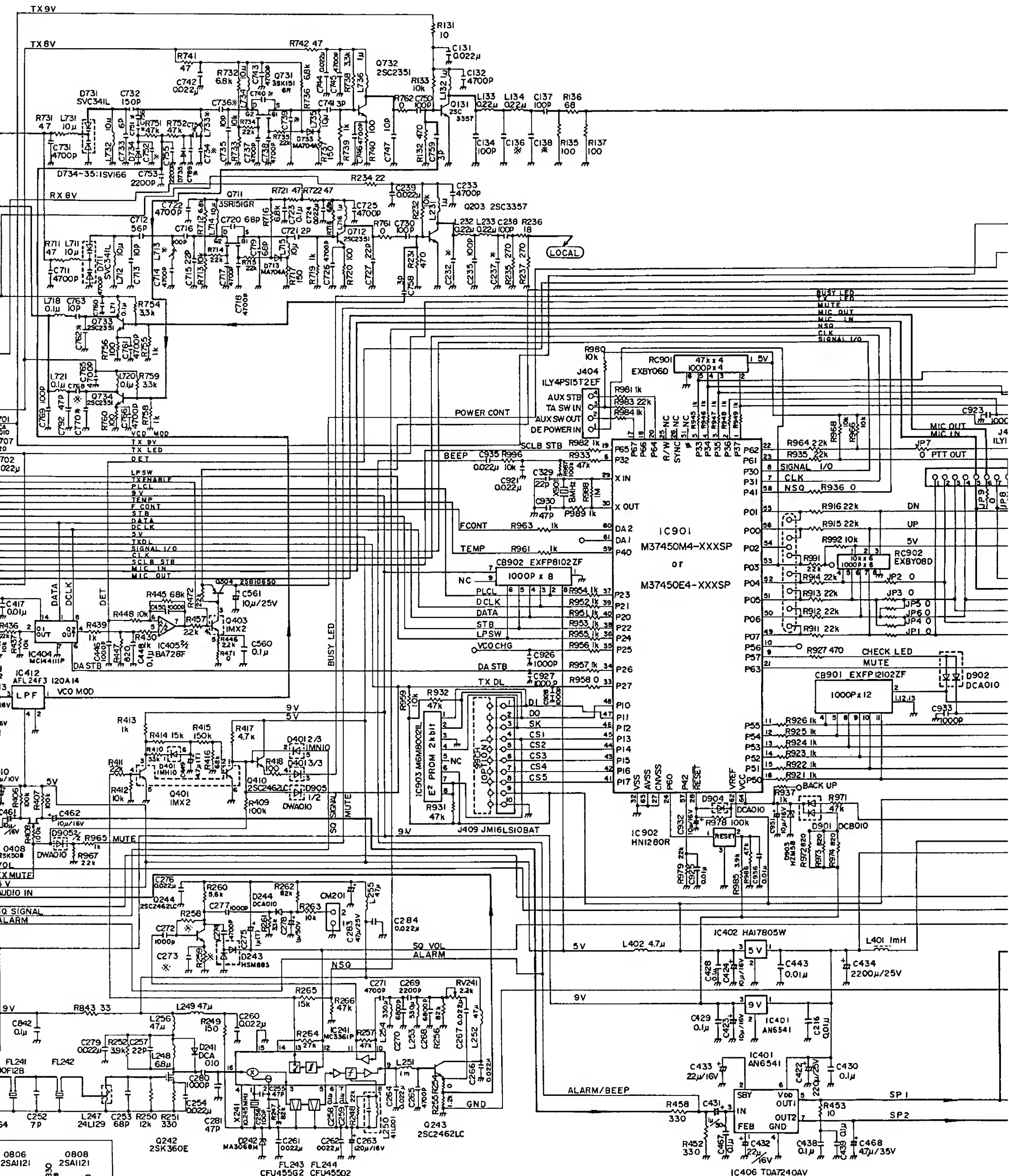

Ref. No.	C136	C138	C201	C202	C203	C204	C205	C206	C207	C208	C209	C213	C214	C215	C216	C217	C218	C219	C220	C221	C232	C237	C212	C225	C226	C227	C228	R258	R259
A Band	220P	100P	270P	750P	680P	100P	33P	100P	680P	620P	270P	270P	750P	750P	270P	680P	270P	750P	750P	270P	56P	39P	68P	100P	100P	220P	0.022	330K	1.5K
B Band	150P	68P	180P	470P	470P	130P	22P	130P	470P	560P	180P	180P	390P	560P	180P	680P	180P	560P	390P	180P	47P	33P	68P	-	-	68P	0.047	330K	1.5K
C Band	100P	-	150P	270P	390P	100P	15P	100P	390P	470P	120P	180P	270P	470P	130P	560P	130P	470P	220P	180P	33P	22P	0.01	-	-	-	0.047	470K	2.2K

Ref. No.	C734	C736	C739	C740	C712	C751	C752	C754	C756	C763	C762	C770	C789	C769	C792	L713	L733	C719	C720	C716	C733	C768
A Band	330P	220P	100P	100P	68P	9P	27P	39P	8P	15P	15P	47P	15P	220P	68P	7.5T	10.5T	100P	100P	150P	5P	7P
B Band	330P	220P	120P	120P	56P	7P	18P	33P	7P	10P	6P	33P	15P	220P	47P	7.5T	9.5T	68P	68P	100P	6P	8P
C Band	220P	180P	100P	100P	56P	6P	22P	27P	6P	10P	3P	22P	39P	100P	47P	6.5T	8.5T	68P	68P	100P	6P	8P

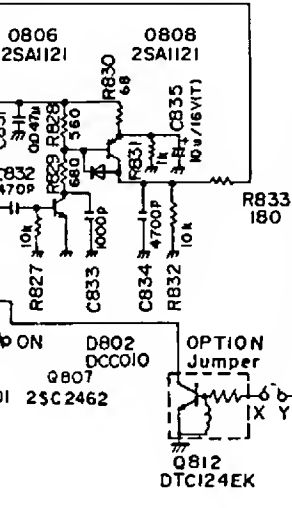

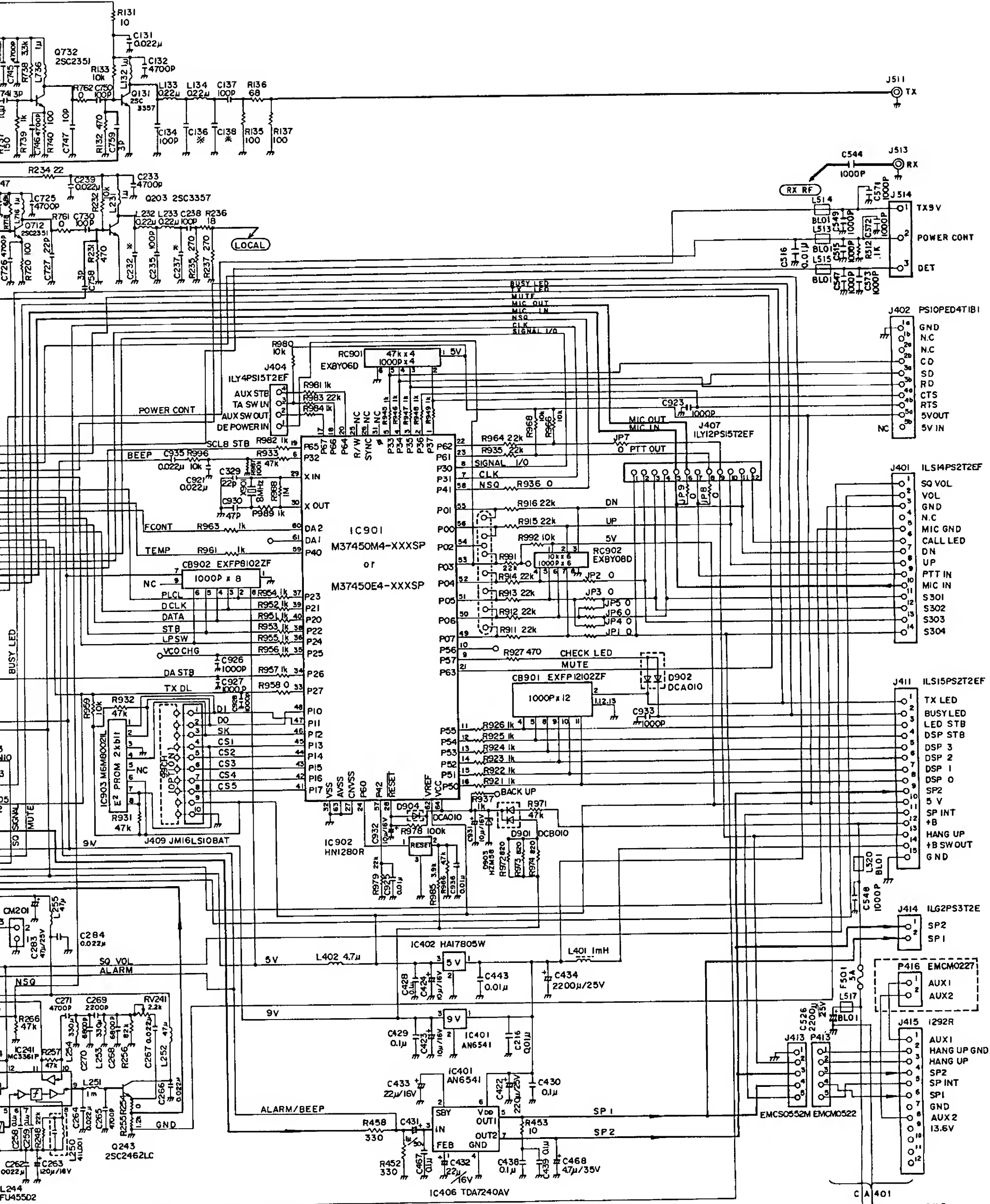

C203	C204	C205	C206	C207	C208	C209	C213	C214	C215	C216	C217	C218	C219	C220	C221	C232	C237	C212	C225	C226	C227	C273	R258	R259
680P	100P	33P	100P	680P	820P	270P	270P	750P	750P	270P	680P	270P	750P	750P	270P	56P	39P	68P	100P	100P	220P	0.022	330K	1.5K
470P	130P	22P	130P	470P	560P	180P	180P	390P	560P	180P	390P	180P	390P	180P	390P	33P	22P	0.01	—	—	68P	0.047	330K	1.5K
390P	100P	15P	100P	390P	470P	120P	180P	270P	470P	130P	560P	130P	470P	220P	180P	33P	22P	0.01	—	—	—	0.047	470K	2.2K

C752	C754	C756	C763	C762	C770	C789	C769	C792	L713	L733	C719	C720	C716	C733	C768
27P	39P	8P	15P	15P	47P	15P	220P	68P	7.5T	0.5T	100P	100P	150P	5P	7P
18P	33P	7P	10P	6P	33P	15P	220P	47P	7.5T	9.5T	68P	68P	100P	6P	8P
22P	27P	6P	10P	3P	22P	39P	100P	47P	6.5T	8.5T	68P	68P	100P	6P	8P

70-0371/0375 (TR-053)
 SCHEMATIC
 DIAGRAM