

# MIDLAND LMR

LAND MOBILE RADIO

## SYNTECH™-II SERVICE MANUAL

### PART THREE (TX/RX UNITS)

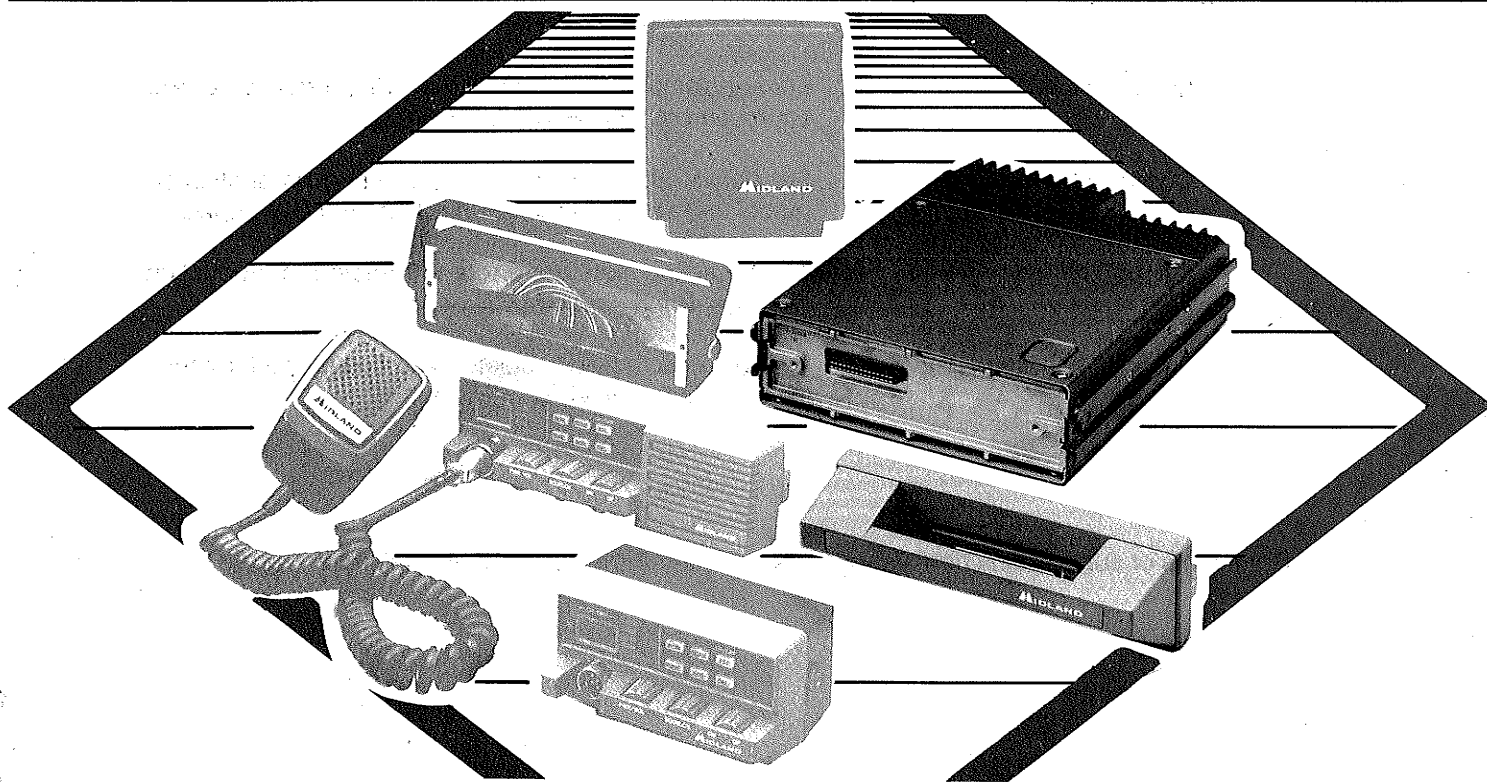

70-3400 AND 70-3800

II-BAND VHF 40-WATT AND 110-WATT

SYN-TECH II service information is published in three volumes.

**Part One** contains general servicing and installation information that is common to the entire SYN-TECH II line.

**Part Two** contains technical data and drawings for the SYN-TECH II Control Heads. Two versions of this section exists: one for the Deluxe Control Head, and one for the Standard Control Head plus the Small-Remote Control Head.

**Part Three** contains technical data and drawings for SYN-TECH II TX/RX units.

This service-manual section is Part Three, and it contains specific technical data and drawings for the 70-3400 and 70-3800 SYN-TECH II TX/RX Units. As necessary, service manual supplements will be published and distributed on the following forms:

- Manual Addition (MA) . . . . . For supplemental information useful in product service or improvement. Printed on BLUE paper.
- Change Notice (CN) . . . . . For details about changes made during production by model and serial number. Printed on YELLOW paper.
- Manual Correction (MC) . . . . . For correcting literature errors not related to production changes. Printed on GREEN paper.
- Technical Bulletin (TB) . . . . . For solutions to field problems and tips for performance improvement. Printed on PINK paper.

Comments or suggestions concerning areas of manual improvement are welcome.

# TABLE OF CONTENTS

<b>SYN-TECH II Service Manuals</b> .....	<b>ii</b>
<b>Table of Contents</b> .....	<b>iii</b>
<b>Acronyms and Abbreviations</b> .....	<b>vi</b>

## **SECTION 1                    GENERAL INFORMATION**

Description .....	1-3
Applicable SYN-TECH II Models .....	1-3
Specifications .....	1-4

## **SECTION 2                    ALIGNMENT**

Pre-Installation Check .....	2-3
Complete Realignment .....	2-4

## **SECTION 3                    SERVICING**

Component Replacement .....	3-3
Eliminating Radio Interference .....	3-7
Metering .....	3-12
Troubleshooting Charts .....	3-13
I/O Addressing .....	3-25
DC Voltages .....	3-31

## **SECTION 4                    CIRCUIT DESCRIPTIONS**

RF Board .....	4-3
40-Watt PA Module .....	4-6
110-Watt PA Module .....	4-7
Logic Board .....	4-7
Audio Routing .....	4-9
Pinout Charts .....	4-11
Option Connector P923 .....	4-15

**SECTION 5****DIAGRAMS**

70-3400 Block Diagram.....	5 - 3
70-3800 Block Diagram.....	5 - 4
70-3421/3851 Wiring Diagram.....	5 - 5
70-4421/4851 Wiring Diagram.....	5 - 6
70-4427/4857 Wiring Diagram.....	5 - 7
70-3422/3852 Wiring Diagram.....	5 - 8
70-4422/4852 Wiring Diagram.....	5 - 9
Logic Board Layouts.....	5 - 10
Logic Board Schematic.....	5 - 11
Audio Routing Diagram.....	5 - 12
RF Board Layouts — Bottom View.....	5 - 13
RF Board Layouts — Top View.....	5 - 14
RF Board Schematic.....	5 - 15
40-Watt PA-Module PCB Layouts.....	5 - 16
40-Watt PA Module Schematic.....	5 - 17
110-Watt PA-Module PCB Layouts.....	5 - 18
110-Watt PA-Module Schematic.....	5 - 19
Trunk Mount Nose-Piece Connector Board.....	5 - 20
IC Details.....	5 - 21
Under-Dash Bracket Exploded View.....	5 - 23
Trunk-Mount Bracket Exploded View.....	5 - 24
Trunk-Mount Nose Piece Exploded View.....	5 - 24
70-3400 Exploded View.....	5 - 25
70-3800 Exploded View.....	5 - 26

**SECTION 6****PARTS**

Parts List.....	6 - 3
70-2336 Parts List and Schematic.....	6 - 13
Replacement Parts Ordering.....	6 - 14

**SECTION 1—General Information**

**1**

**SECTION 2—Preparation**

**2**

**SECTION 3—Servicing**

**3**

**SECTION 4—Circuit Descriptions**

**4**

**SECTION 5—Diagrams**

**5**

**SECTION 6—Parts**

**6**

## ACRONYMS AND ABBREVIATIONS

Below is a list of common electrical acronyms and abbreviations used in this manual.

ANI .....	Automatic Number Identification
CTCSS .....	Continuous Tone-Controlled Squelch System
DCS (or CDCSS) .....	Continuous Digital-Controlled Squelch System
DTMF .....	Dual Tone Multi-Frequency
E <sup>2</sup> PROM .....	Electrically Erasable Programmable Read Only Memory
MIL .....	Military Specification
RX .....	Receive
SINAD .....	The ratio in decibels of signal + noise + distortion to noise + distortion
TX .....	Transmit
VCO .....	Voltage Controlled Oscillator

**SECTION 1**

---

**GENERAL INFORMATION**

**GENERAL INFORMATION**

---

70-3400/3800

**NOTES**



**DESCRIPTION**

The 70-3400 and 70-3800 TX/RX Units are RF packages for the SYN-TECH II high-band VHF FM mobile transceivers. The 70-3400 Unit is capable of producing 40 W RF output (45 W optional), the 70-3800 produces 110 W RF output. A-Band radios operate from 136 MHz to 160 MHz; B-Band radios operate from 150 MHz to 174 MHz. The TX/RX Units operate any channel frequency within its respective band, automatically (without retuning).

Generally, the SYN-TECH II is comprised of two parts: a TX/RX Unit, which is the major portion of the radio; and a detachable Control Head. SYN-TECH II radios are compact and can be mounted under a vehicle dashboard; but, if available space is limited, the SYN-TECH II radio can be purchased with its control panel detached so that the bulk of the radio can be mounted under a seat or in the trunk; only the control panel need be mounted in the operator's reach.

If an under-dash configuration is purchased, the TX/RX Unit is shipped with the Control Panel attached to it.

If a trunk-mount configuration is purchased, the TX/RX Unit has a cable-interface board and handle assembly mounted in place of the Control Head. A cable-interface board and rear cover are also added to the Control Head. The two units must be connected together with a multi-conductor cable when installed.

The chassis of the SYN-TECH II TX/RX Unit is constructed of cast aluminum with sectional cavities that house three major printed circuit boards. The RF Board contains transmitter, receiver, and synthesizer circuitry and is located on the underside of the radio. The Logic Board contains the microcomputer and interface circuitry and is mounted on the top side of the radio. Another, unused cavity is located on the radio topside to accommodate optional circuit boards. The third PC board is located inside the rear heat sink which comprises the PA Module. The PA Board is accessible by removal of the heat sink top cover.

**APPLICABLE SYN-TECH II MODELS**

Model numbers 70-3400 and 70-3800 identify a TX/RX Unit, which is a SYN-TECH II subassembly not the entire transceiver.

MIDLAND models 70-342x, 70-385x, 70-442x, and 70-485x SYN-TECH II transceivers consist of two major components: the TX/RX Unit (MIDLAND model number 70-3400 or 70-3800) and the Control Head (MIDLAND model number 70-0001, 70-0002, or 70-0007).

Model numbers of SYN-TECH II packages that contain the 70-3400 and 70-3800 TX/RX Units are defined in **Table 1 - 1**.

# GENERAL INFORMATION

70-3400/3800

MODEL NUMBER	MOUNTING*	RF OUTPUT POWER	CONTROL HEAD	FREQUENCY BAND (MHz)	TX/RX UNIT
70-3421A	UD	40 WATTS	STANDARD	136—160	70-3400A
70-3421B	UD	40 WATTS	STANDARD	150—174	70-3400B
70-3422A	UD	40 WATTS	DELUXE	136—160	70-3400A
70-3422B	UD	40 WATTS	DELUXE	150—174	70-3400B
70-4421A	TM	40 WATTS	STANDARD	136—160	70-3400A
70-4421B	TM	40 WATTS	STANDARD	150—174	70-3400B
70-4422A	TM	40 WATTS	DELUXE	136—160	70-3400A
70-4422B	TM	40 WATTS	DELUXE	150—174	70-3400B
70-4427A	TM	40 WATTS	SMALL REMOTE	136—160	70-3400A
70-4427B	TM	40 WATTS	SMALL REMOTE	150—174	70-3400B
70-3851A	UD	110 WATTS	STANDARD	136—160	70-3800A
70-3851B	UD	110 WATTS	STANDARD	150—174	70-3800B
70-3852A	UD	110 WATTS	DELUXE	136—160	70-3800A
70-3852B	UD	110 WATTS	DELUXE	150—174	70-3800B
70-4851A	TM	110 WATTS	STANDARD	136—160	70-3800A
70-4851B	TM	110 WATTS	STANDARD	150—174	70-3800B
70-4852A	TM	110 WATTS	DELUXE	136—160	70-3800A
70-4852B	TM	110 WATTS	DELUXE	150—174	70-3800B
70-4857A	TM	110 WATTS	SMALL REMOTE	136—160	70-3800A
70-4857B	TM	110 WATTS	SMALL REMOTE	150—174	70-3800B

\*UD = Under-Dash TM = Trunk-Mount

## SPECIFICATIONS

Refer to EIA-152-C, EIA/TIA-204-D, and DOC RSS-119, Issue 4 for standard of performance and method of measurement.

### GENERAL

#### OPERATING VOLTAGE:

Nominal, 70-3400: 13.6 VDC, negative ground

Nominal, 70-3800: 13.4 VDC, negative ground

Range: 10.5 to 16 VDC

**TEMPERATURE RANGE:** -30C to +60C

**ANTENNA IMPEDANCE:** 50  $\Omega$ , unbalanced

**FREQUENCY CONTROL:** Phase-Lock-Loop synthesized

#### FREQUENCIES OF OPERATION:

A-Band: 136—160 MHz

B-Band: 150—174 MHz

**CHANNEL CAPACITY:** Up to 320 transmit and 320 receive

**CHANNEL FREQUENCY SPREAD (without retuning):**

Transmit: 24 MHz  
Receive: 24 MHz

**FREQUENCY TOLERANCE AND STABILITY:**

Standard: 5.0 ppm both TX and RX  
Optional: 2.0 ppm both TX and RX

**DUTY CYCLE:** Intermittent. 1 min TX, 4 min RX  
(Per EIA 152-C)

**HIGH HUMIDITY:** 95% at 50C per EIA-152-C, sec.13

**VIBRATION STABILITY:** Per EIA 152-C and applicable portions of MIL810C/D

**SHOCK STABILITY:** Per EIA 152-C and applicable portions of MIL810C/D

**CURRENT DRAIN:**

Standby: 0.5 A DC (varies with options)  
Receive (at rated audio): 2.00 A DC  
Transmit at 40 W (70-3400/4400): 9.0 A DC  
Transmit at 110 W (70-3800/4800): 25.0 A DC

**DIMENSIONS (H x W x D):**

Under-Dash:  
70-3421/3422 (40 W): 57 x 185 x 300 mm (2.3" x 7.3" x 11.8")  
70-3821/3822 (110 W): 57 x 185 x 350 mm (2.3" x 7.3" x 13.8")  
  
Trunk-Mount (TX/RX Unit only):  
70-4421/4422/4427 (40 W): 57 x 185 x 320 mm (2.3" x 7.3" x 12.6")  
70-4821/4822/4827 (110 W): 57 x 185 x 370 mm (2.3" x 7.3" x 14.6")  
  
Standard Remote Control Head: 57 x 185 x 75 mm (2.3" x 7.3" x 3.0")  
Small Remote Control Head: 57 x 120 x 75 mm (2.3" x 4.7" x 3.0")  
Remote Speaker: 121 x 121 x 72 mm (4.8" x 4.8" x 2.8")

**WEIGHT:**

Under-Dash:  
70-3421/3422 (40 W): 3.1 kg (6.8 lbs)  
70-3821/3822 (110 W): 3.8 kg (8.4 lbs)  
  
Trunk-Mount (TX/RX Unit only):  
70-4421/4422/4427 (40 W): 3.2 kg (7.0 lbs)  
70-4821/4822/4827 (110 W): 3.9 kg (8.5 lbs)  
Standard Remote Control Head: 0.36 kg (0.8 lbs)  
Small Remote Control Head: 0.23 kg (0.5 lbs)  
Remote Speaker: 0.63 kg (1.38 lbs)

# GENERAL INFORMATION

---

70-3400/3800

## TRANSMITTER

### CARRIER POWER OUTPUT:

70-34xx/44xx: 40 W minimum (45 W optional), adjustable down to 20 W, and 1—10 W with Low-Power option

70-48xx/48xx: 110 W minimum, adjustable down to 55 W

**MODULATION SYSTEM:** 16K0F3E, Direct FM

**AUDIO FREQUENCY RESPONSE:** Per EIA and DOC specifications

**AUDIO HARMONIC DISTORTION:** 3% THD (1 kHz tone at 3.0 kHz deviation, and 750  $\mu$ s de-emphasis)

**SYSTEM DEVIATION:** 5 kHz maximum

**MODULATION LIMITING** Instantaneous peak clipping with low-pass audio filtering

**HUM AND NOISE** 55 dB

**OCCUPIED BANDWIDTH** Less than -60 dB of carrier power 30 kHz outside carrier frequency

**TRANSMIT CARRIER ATTACK TIME** 20 ms max. for 50% rated power

**CONDUCTED SPURIOUS EMISSIONS** Less than 2.5  $\mu$ W from 1 to 1000 MHz

**MICROPHONE INPUT LEVEL** -8 dBm  $\pm$ 3 dB at 600  $\Omega$

**OUTPUT PROTECTION:** Shall withstand without damage: 5 minutes of operation into a 20:1 load mismatch with any standing wave variance.

**OUTPUT STABILITY:** Shall not exceed spurious emission limits herein while operating into a 5:1 load mismatch with full standing-wave variance.

**RECEIVER****SENSITIVITY:**

12 dB SINAD 0.35  $\mu$ V maximum  
Threshold Squelch Break: 0.18  $\mu$ V maximum or 6 dB SINAD  
Tight Squelch Break: 0.8 to 1.2  $\mu$ V

**RECEIVER ATTACK TIME:** 50 ms

**RECEIVER SQUELCH CLOSING TIME:** 100 ms

**ACCEPTABLE RF DISPLACEMENT:** 3.0 kHz minimum

**ADJACENT CHANNEL REJECTION:** 90 dB at 30 kHz

**SPURIOUS RESPONSE IMMUNITY** 90 dB

**INTERMODULATION IMMUNITY:** 77 dB minimum (82 dB optional)

**AUDIO POWER OUTPUT:**

Under-Dash Radio: 1.0 W at 3% THD into its internal speaker, or  
12 W 3% THD into a 4- $\Omega$  external speaker  
Trunk-Mount Radio: 12 W at 3% THD into the 4- $\Omega$  external  
speaker

**AUDIO FREQUENCY RESPONSE:** Per EIA and DOC specifications

**HUM AND NOISE:**

Un-squelched: 45 dB  
Squelched: 60 dB

**CONDUCTED SPURIOUS EMISSIONS** 200  $\mu$ V across 50  $\Omega$  (800 pW) from DC to  
1 GHz

**INTERMEDIATE FREQUENCIES:** 21.4 MHz (1st) and 455 kHz (2nd)

— All specifications subject to change without notice —

# GENERAL INFORMATION

---

70-3400/3800

## NOTES

**SECTION 2**

---

**PREPARATION**

# PREPARATION

---

70-3400/3800

## NOTES



The 70-3400 and 70-3800 SYN-TECH II TX/RX Units are capable of operating across a 24 MHz channel frequency spread. They do not require optimizing alignment, even when reprogrammed with new customer frequencies. Only general transmitter performance should be checked. **COMPLETE REALIGNMENT MAY BE NECESSARY** after a component that affects transceiver tuning has been replaced. Realignment requires transceiver operation on special frequencies; therefore, the transceiver must be reprogrammed specifically for alignment, the Remote-Control mode of the 70-1080A Programmer can be used, or the RX-TX Test Commands of the 70-1488 PC Programming software can be used.

**PRE-INSTALLATION CHECK**

• **Setup**

1. Remove the four screws securing the bottom cover and the cover itself.
2. If not already in place, connect the proper Control Head to the TX/RX Unit.
3. Connect a resistive, 50-Ω RF load (with a wattmeter) to Antenna Connector J502.
4. Connect 13.6 V DC power to J506. Connect [+] to pin 2 and [-] to pin 1.
5. Turn the radio on, turn Scan and Priority Sampling off, turn MON on, turn selective signaling options off.

• **Carrier Frequency**

6. Initiate transmit on any channel. Measure transmitted RF carrier frequency without modulation and, if necessary, adjust REFERENCE OSCILLATOR X101 for zero carrier frequency offset.

• **RF Output Power**

7. Deselect the Low Power option (if installed), then initiate transmit on any channel. Measure power of RF output at 50-Ω Antenna Connector J502 and, if necessary, adjust H.PWR as follows:

70-3400: Adjust RV502 to obtain 40 W.

70-3800: Adjust RV501 to obtain 110 W.

RV501 and RV502 are located on the PA Module under the removable rubber cap.

If the LOW Power option is in place (70-3400 only); select LOW power, and initiate transmit again. Measure RF output power and, if necessary, adjust L.PWR RV501 to obtain desired LOW-power level.

• **Maximum Deviation**

Two deviation limit adjustments exist: one for channels in the upper half of the frequency band, the other for the lower half.

8. Select a channel with transmit frequency in the lower half of the band (below 148.48 MHz for A-Band units, or below 162.56 MHz for B-Band). If CTCSS or DCS is used, be sure this channel also is programmed to send the same.
9. Disconnect the hand microphone from its front panel receptacle P317. Apply 3 V<sub>rms</sub> of 1000 Hz signal to pin 1 of MIC JACK P317, then initiate transmit by grounding pin 4. Measure total carrier deviation to assure it is below 5 kHz (including CTCSS/DCS signal).
10. Repeat step 9 with channels in the upper half of the frequency band (above 148.48 MHz for A-Band units, or above 162.56 MHz for B-Band units).

**NOTE:** If adjustments are needed, see MODULATOR ALIGNMENT on following page 2 - 6.

# PREPARATION

70-3400/3800

## COMPLETE REALIGNMENT

The 70-3400 and 70-3800 TX/RX Units are capable of operating over a 24 MHz channel-frequency spread without retuning. The following procedure details entire transceiver realignment, and is needed only if a component that affects alignment has been replaced. RADIO RE-PROGRAMMING WITH TEST FREQUENCIES IS REQUIRED. Either the 70-1080A Programmer, or 70-1488 PC Programming Software can be used.

Table 2 - 1 — Test Equipment Required

TEST INSTRUMENT	CAPABILITIES	USE
Regulated DC Power Supply	13.8 VDC, 30 amps adjustable voltage	Radio power source
RF Wattmeter for 70-3400:  for 70-3800:	75 watts; 136—174 MHz ; 50- $\Omega$ circuit 150 watts; 136—174 MHz; 50- $\Omega$ circuit	Transmitter power measurements
RF Load Resistor	50 $\Omega$ ; 200 W	Antenna dummy load
Frequency Modulation Meter	136—174 MHz; peak-responding, 5kHz range	Modulation level measurements
Frequency Meter or Frequency Counter	136—174 MHz; 1.0 ppm accuracy	Carrier frequency measurement
Audio Generator	1000 kHz sine-wave; 0-3 V <sub>rms</sub> output	Modulation level measurements
RF Signal Generator	136—174 MHz range; 0.1—1K $\mu$ V output; 3 kHz FM mod. with 1kHz tone	All receiver measurements
Distortion Analyzer	1 kHz notch; 1% measuring range	Receiver performance test and I.F. alignment
Load Resistor (audio)	4 $\Omega$ , 20 W	Speaker load for all receiver measurements
AC Voltmeter	10 mV to 3 V <sub>rms</sub>	Audio level adjustments
Oscilloscope	DC to 500 kHz bandwidth	DCS alignment
Digital Multimeter	0.1 to 20 V DC	Test point measurements and power supply setup
SYN-TECH II Programmer	MIDLAND 70-1080A	Manual radio control

**SETUP**

1. Remove eight securing screws and the top and bottom covers. Loosen two securing screws and the PA Module cover.
2. If not already in place, connect the proper Control Head to the TX/RX Unit.
3. Connect a resistive, 50-Ω RF load and a watt-meter to Antenna Connector J502.
4. Connect 13.6 volts DC power to transceiver J506. Connect [+] to pin 2 and [-] to pin 1.
5. Connect a 4-Ω, 20-watt resistor to pins 4 and 6 of the Accessory Plug. The jumper between pin 5 and 6 must be temporarily disconnected to make this connection. The resistor serves as a constant load to replace the speaker's inconsistencies.

**CAUTION:** Both speaker terminals are LIVE! Never ground either one. Connect grounded receiver-audio measuring equipment to **only one side** of the speaker, and chassis ground. Normally, voltage measurements will be half of true values.

6. Turn the radio on, set the VOLUME control to a mid-position, and set the SQUELCH control fully counterclockwise.
7. Connect the programmer to Programming Port J909. Upload the radio programming Data-Packet into the programmer and initiate its Remote Control Mode. Refer to appropriate Operator's Manual for instructions.

**SYNTHESIZER ALIGNMENT**

• **VCO Resonance**

1. Select the Remote-Control Mode of the Programmer and enter the following test frequencies:

	A-Band	B-Band
RX Frequency:	136.00 MHz	150.00 MHz
TX Frequency:	136.00 MHz	150.00 MHz

2. Adjust LOW-CHANNEL RX TANK L702 (labeled "RX L") to obtain 2.5 V DC on CM118 pin 3 (VCO STEERING).
3. Activate the transmit mode (using the Programmer). Adjust LOW-CHANNEL TX TANK L722 (labeled "TX L") to obtain 2.0 V DC on CM118 pin 3.
4. Change the test frequencies to:
 

	A-Band	B-Band
RX Frequency:	148.20 MHz	162.30 MHz
TX Frequency:	148.50 MHz	162.60 MHz
5. Adjust HIGH-CHANNEL RX TANK L712 (labeled "RX H") to obtain 2.5 V DC on CM118 pin 3.
6. Activate transmit, then adjust HIGH-CHANNEL TX TANK L732 (labeled "TX H") to obtain 2.0 V DC on CM118 pin 3.

• **Reference Oscillator**

7. Initiate transmit on any channel. Measure transmitted RF carrier frequency without modulation and, if necessary, adjust REFERENCE OSCILLATOR X101 for zero carrier frequency offset (within 100 Hz of channel frequency if using a frequency counter).

**40-WATT PA MODULE  
(70-3400 TX/RX Units only)**

1. Change the TX test frequency to 160.00 MHz, for A-Band units, or 174.00 MHz for B-Band units.
2. Deselect the LOW Power option (if installed) and set H.PWR RV502 to maximum (full clockwise).
3. Activate transmit mode, then adjust CV501 and CV504 to obtain maximum RF power at Antenna Connector J502.
4. Adjust RV502 to obtain 40 W power at J502. If the LOW Power option is in place, select LOW power, and initiate transmit again. Measure RF output power and adjust L.PWR RV501 to obtain desired LOW-power level.



## PREPARATION

70-3400/3800

### 110-WATT PA MODULE (70-3800 TX/RX Units only)

1. Change the TX test frequency to 160.00 MHz for A-Band units, or 168.00 MHz for B-Band units.
2. Set PWR RV501 to maximum (full clockwise).
3. Set CV503 and CV504 to maximum capacitance (plates fully meshed).
4. Initiate transmit, then adjust CV505 to obtain maximum RF power at Antenna Connector J502.
5. If output power is less than 135 W, fine-tune CV504 to obtain maximum power; otherwise, skip this step.
6. Change the TX test frequency to 143.00 MHz for A-Band units, or 151.00 MHz for B-Band units.
7. Initiate transmit and adjust PWR RV501 to obtain 110 W power at J502. RV501 is located on the PA Module under a removable rubber cap.

### MODULATOR ALIGNMENT

Always perform Modulator Alignment in its entirety; the following adjustments are interactive.

#### • Modulation Limiting

Two deviation limit adjustments exist: one for channels in the upper half of the frequency band, the other for the lower half.

1. Change the TX test frequency to 148.00 MHz for A-Band units, or 162.00 MHz for B-Band units.
2. Clear CTCSS or DCS encode.
3. Disconnect the hand microphone from its front panel receptacle P317. Apply 3  $V_{rms}$  of 1000 Hz signal to pin 1 of MIC JACK P317, then initiate transmit (if not using the 70-1080A Programmer, ground P317-pin 4). Measure total carrier deviation and, if needed, adjust FL MOD LIMIT RV104 to obtain  $\pm 4.2$  kHz.

4. Change the TX test frequency to 160.00 MHz for A-Band units, or 174.00 MHz for B-Band units.
5. Apply 3  $V_{rms}$  of 1000 Hz signal to pin 1 of MIC JACK P317, then initiate transmit. Measure total carrier deviation and, if needed, adjust FH MOD LIMIT RV105 to obtain  $\pm 4.2$  kHz.

#### • VCO Modulation Port

6. Set CTCSS RV902 (accessed from the radio topside) to mid-range and set TONE2 RV101 (on the bottom side) near minimum.
7. Change the TX test frequency to 154.10 MHz for A-Band units, or 168.15 MHz for B-Band units.
8. Remove external modulation signals, enter the DCS code +023, then initiate transmit.
9. Observe the modulation level of the distorted recovered waveform and adjust TONE1 RV102 to obtain  $\pm 700$  Hz deviation at the peaks.

#### • Reference-Oscillator Modulating Port

10. While observing recovered modulation on an oscilloscope, adjust TONE2 RV101 to obtain a square DCS waveform as shown below. If modulation level exceeds  $\pm 700$  Hz deviation, reduce TONE1 RV102 slightly, then repeat this step.

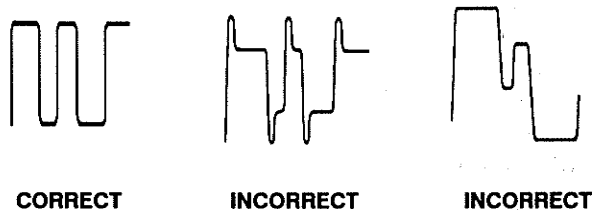

**WARNING:** Use equipment with DC coupling to avoid distortion of the DCS waveform that contains frequencies as low as 6 Hz.

**NOTE:** Observe the DCS waveform at pin 31 of J106 with an oscilloscope for a better example. The recovered DCS waveform above should be similar to it.

11. Change the TX test frequency to 148.00 MHz for A-Band units, or 162.00 MHz for B-Band units.

12. Apply 3 V<sub>rms</sub> of 1000 Hz signal to pin 1 of MIC JACK P317, then initiate transmit. Make sure total carrier deviation (1kHz tone plus DCS modulation) does not exceed ±5.0 kHz. If it must be turned down, adjust F<sub>L</sub> MOD LIMIT RV104.
13. Change the TX test frequency to 160.00 MHz for A-Band units, or 174.00 MHz for B-Band units.
14. Apply 3 V<sub>rms</sub> of 1000 Hz signal to pin 1 of MIC JACK P317, then initiate transmit. Make sure total carrier deviation (1kHz tone plus DCS modulation) does not exceed ±5.0 kHz. If it must be turned down, adjust F<sub>H</sub> MOD LIMIT RV105.

• **Microphone Gain**

15. Change the TX test frequency to 154.10 MHz for A-Band units, or 168.15 MHz for B-Band units.
16. Clear DCS encode.
17. Apply 310 mV<sub>rms</sub> of 1000 Hz sine-wave signal to pin 1 of MIC JACK P317; then initiate transmit. Measure carrier deviation and, if needed, adjust MIC GAIN RV103 to obtain 3 kHz.

• **CTCSS Level**

18. Enter the 100.0 Hz CTCSS tone and initiate transmit. Adjust CTCSS RV902 to obtain CTCSS modulation of ±700 Hz deviation). RV902 is located on the radio topside of the Logic Board.

• **Burst-Tone Level**

19. Clear the CTCSS tone and enter the highest Burst-Tone frequency used. Initiate transmit, then adjust BRST RV901 for 3 kHz deviation. RV901 is located on the radio topside of the Logic Board. If more than one Burst Tone is used, adjust as necessary to keep modulation level of all tones between ±2.0 kHz and ±3.5 kHz deviation.

**RECEIVER ALIGNMENT**

1. Change the RX test frequency to 148.20 MHz for A-Band units, or 162.30 MHz for B-Band units.

• **First Injection**

2. Adjust L222 and L223 to obtain maximum DC voltage on Injection Metering Point CM118 pin 4.

• **Preselector Alignment**

3. Apply sufficient unmodulated, on-channel RF signal to 50-Ω antenna connector J502 to obtain approximately 20 dB quieting. Adjust L201, L202, L207, L208, and L209 for maximum quieting indication (peak positive voltage) at CM118 pin 5. Readjust input signal, as necessary, to maintain 20 to 30 dB quieting while aligning.

• **Quadrature Detector**

4. Apply 1 mV of modulated (by 1 kHz tone at 3 kHz deviation) on-channel RF signal to Antenna Connector J502. Adjust DETECTOR L262 for maximum audio output.

• **First I.F.**

5. Apply enough modulated (by 1 kHz tone at 3 kHz deviation) on-channel carrier to maintain 12 to 15 dB SINAD. Adjust L221 and L261 for best SINAD.
6. Apply 1 mV modulated (by 1 kHz tone at 3 kHz deviation) on-channel carrier. Readjust L221 and L261 for minimum receive audio distortion. **NOTE:** If a distortion analyzer is not available, this step may be deleted although distortion specifications may not be met.

• **Tight Squelch**

7. Set the front panel SQUELCH control to maximum (full clockwise). Set SQUELCH RANGE RV261 fully counterclockwise.
8. Apply 1.5 μV of unmodulated on-channel RF signal to the 50-Ω antenna connector. Adjust SQUELCH RANGE RV261 clockwise just until squelch opens (audio on).



# PREPARATION

70-3400/3800

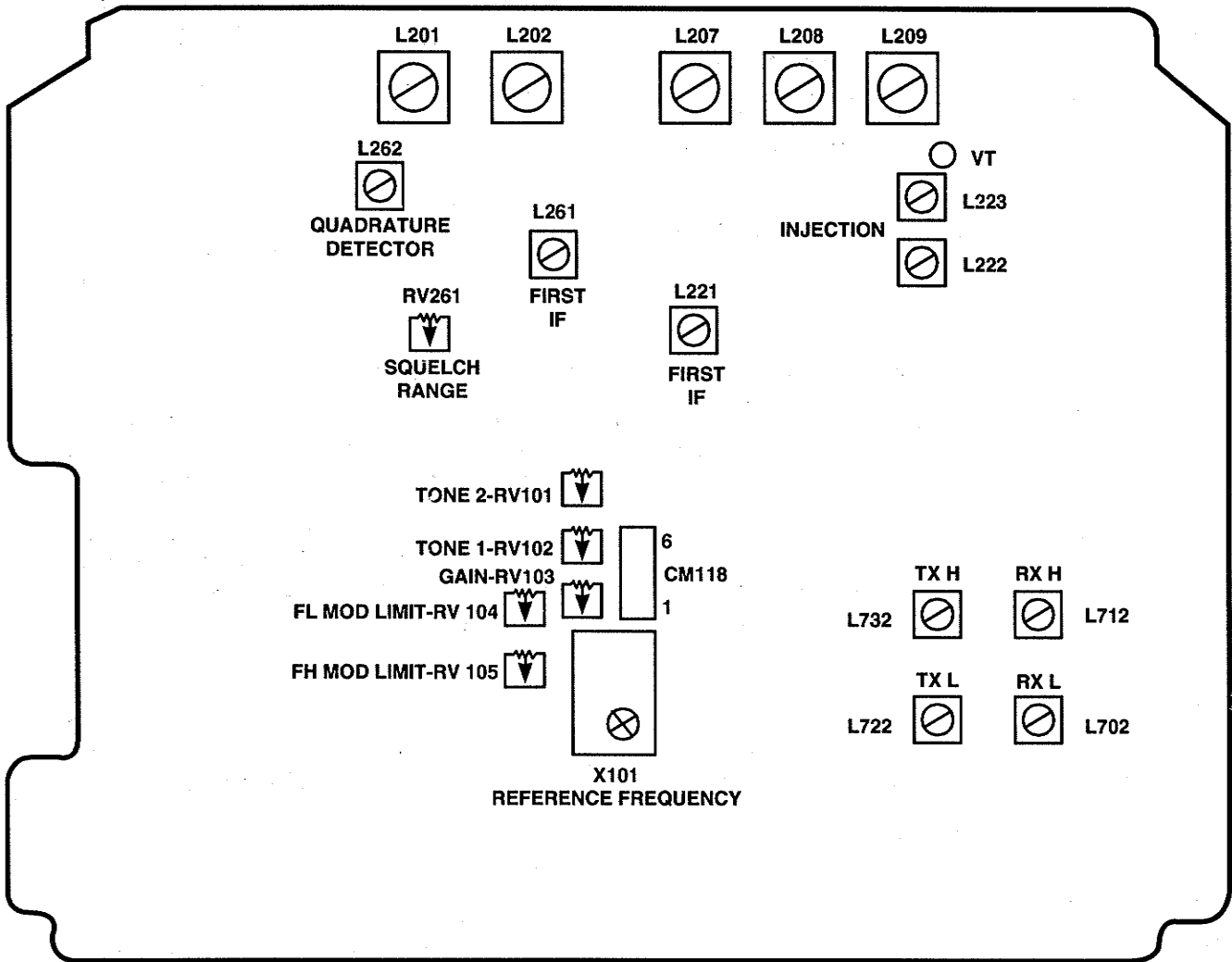

Figure 2 - 1 — Adjustment Map, RF Board

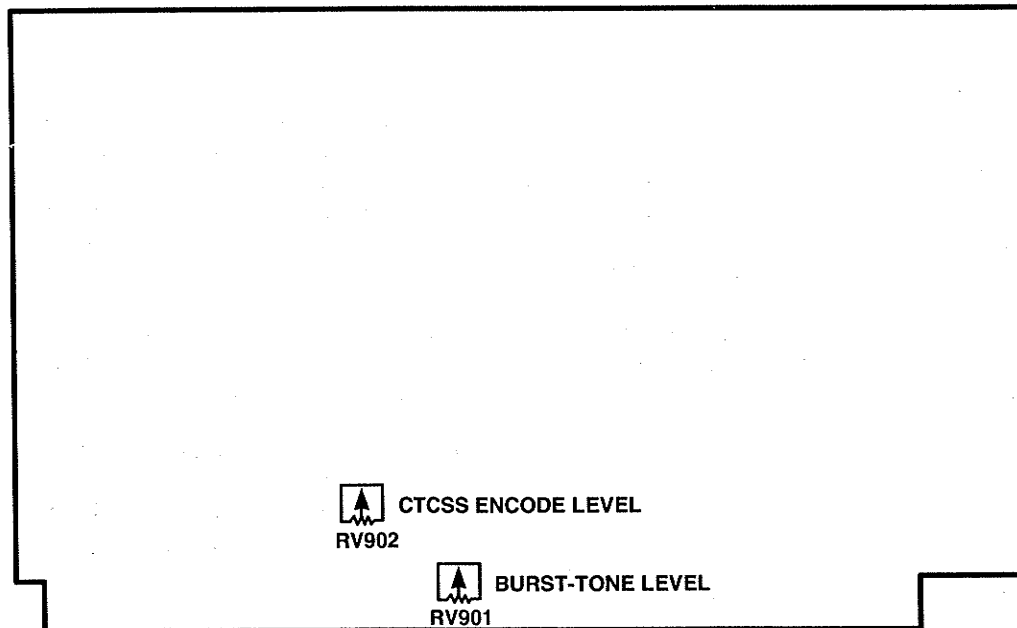
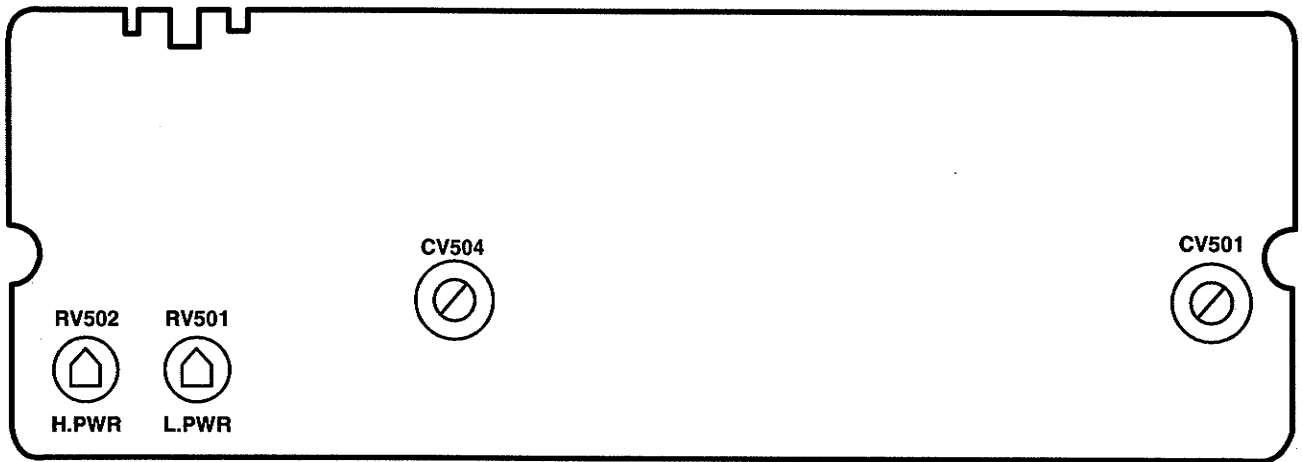
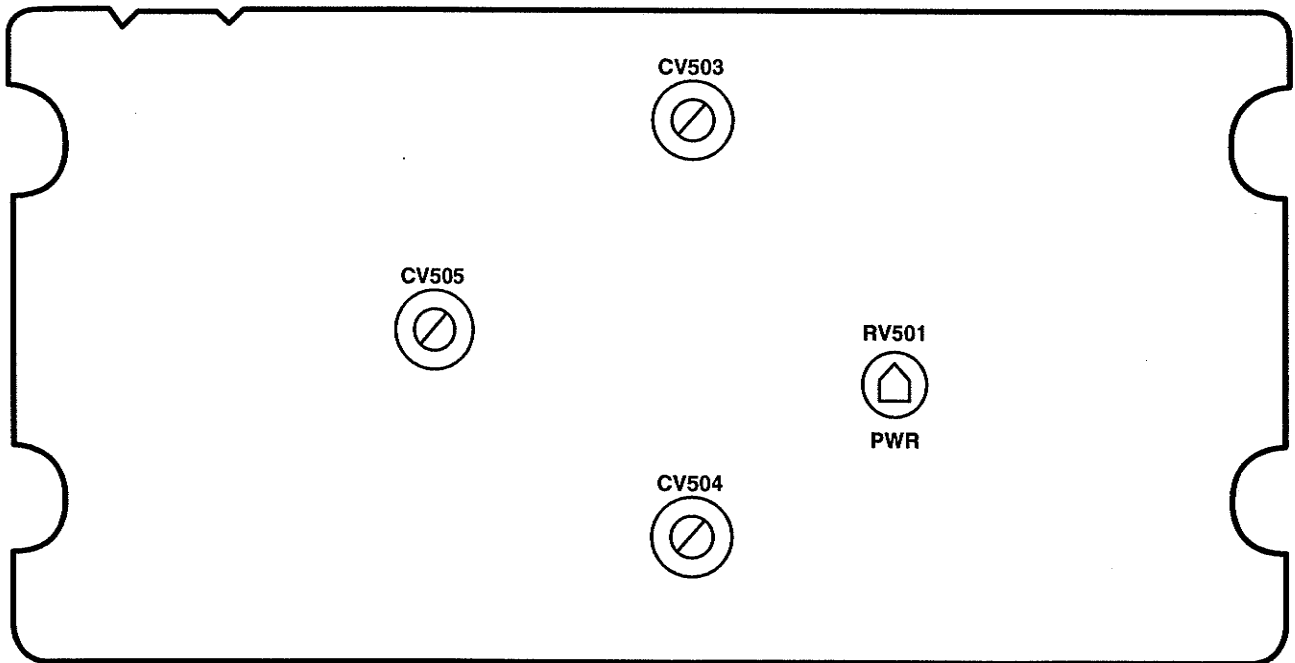

Figure 2 - 2 — Adjustment Map, Logic Board



**Figure 2 - 3 — Adjustment Map, 40 W PA Module**



**Figure 2 - 4 — Adjustment Map, 110 W PA Module**

# PREPARATION

---

70-3400/3800

## NOTES



**SECTION 3**

**SERVICING**

**NOTES**

## **COMPONENT REPLACEMENT**

### **STATIC POTENTIALS**

Many of the transceiver components are susceptible to higher voltages whether they are in or out of a circuit. Avoid static or AC-line potentials when handling components and circuit boards. Prevent damage from electrically "hot" tips that carry AC-line or static potential by using a grounded soldering iron. The only way to alleviate risk of component damage from static discharge is to make sure all of the objects that touch the circuitry during component replacement carry the same potential. Since the soldering iron is grounded, everything else must be grounded: the bench, the equipment being worked on, and you. There usually isn't a need to wire yourself to your bench unless you work on carpeting on dry-air days. Just touch bench ground when you sit down so that you and the grounded work area are at the same potential.

**3**

### **REPLACING CHIP CAPACITORS AND RESISTORS**

This section describes the best way to remove a chip component and install a new one. Chip components do not have leads; they have metallic film on end-surfaces to solder to. Often the surface is tinned with solder. Because the metallic film can be easily damaged by contamination and excessive heat, these components must be soldered very carefully. No chip component can be unsoldered, then resoldered without damage. Always discard a used component.

#### **• ITEMS REQUIRED:**

- Grounded temperature-controlled soldering iron with a 1/32" flat-blade tip. The tip temperature must be maintained at approximately 600 degrees Fahrenheit.
- 60/40 electronics-grade solder, 22 gauge or thinner, with rosin flux.
- Tweezers or longnose pliers.
- Thin desoldering-wick.
- Isopropyl alcohol or equivalent for solvent.
- Rosin solder-flux. **DO NOT USE ACID FLUX.**

## SERVICING

70-3400/3800

- **Procedure:**

1. Place the solder iron tip directly on the defective component to melt the glue under the component, then solder as shown in **Figure 3 - 1**. Remove the component with tweezers or longnose pliers. Discard the component.

**CAUTION:** Application of too much solder can create solder bridges between PC patterns under the soldered component and around the pad.

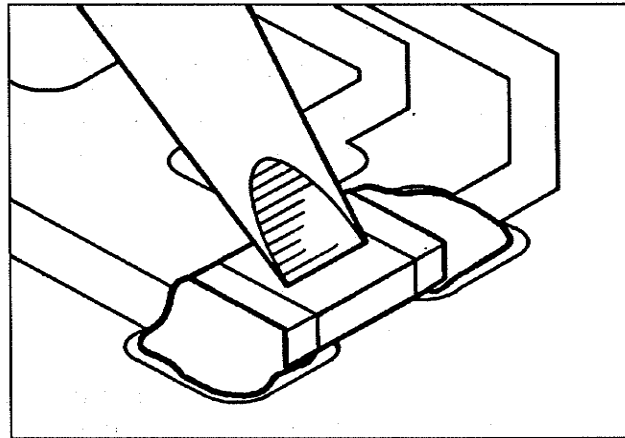

**Figure 3 - 1**

2. Completely remove old solder, old glue, and any other contaminants from the area with desoldering-wick and solvent.
3. Apply only enough fresh solder to coat the clean PC pad as shown in **Figure 3 - 2**.

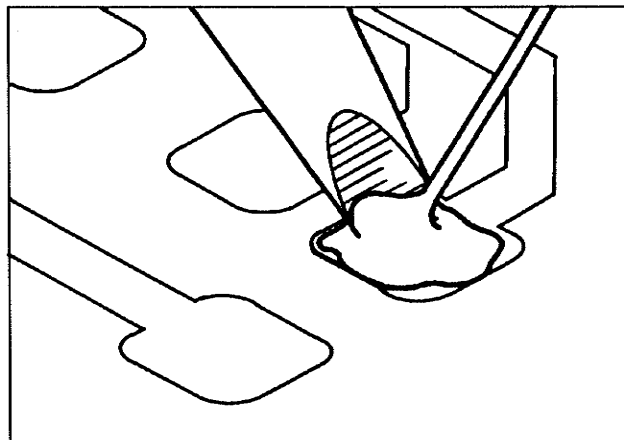

**Figure 3 - 2**

- Place component and briefly heat the new solder and pad while holding the component with tweezers. Do not touch the new component with the iron. Only heated solder should touch the component to make a light "tack" bond to it. See Figure 3 - 3.

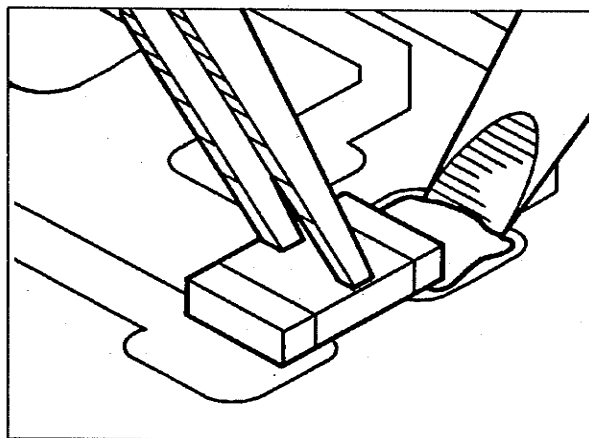

Figure 3 - 3

- With one component end tacked to hold it, the other end can be soldered. Carefully apply heat to the PC pad while adding only enough fresh solder to produce a clean fillet as in Figure 3 - 4 — do not apply too much solder, otherwise it may flow underneath and short the pads together. Let the hot solder flow onto the component—do not touch the component with the iron. Repeat to finish the other end of the component. Solder must adhere to all metallic end-surfaces on both ends as shown in Figure 3 - 5.

**CAUTION:** Avoid direct contact to the chip component with the iron tip. Too much heat and contamination will break down the metallic film on component ends resulting in loss of internal connection (a capacitor is comprised of several wafer plates that connect through the metallic end-surfaces). If satisfactory solder adhesion does not occur, the metallic end surface has been damaged and the chip component should be replaced again. More soldering will only damage the component further.

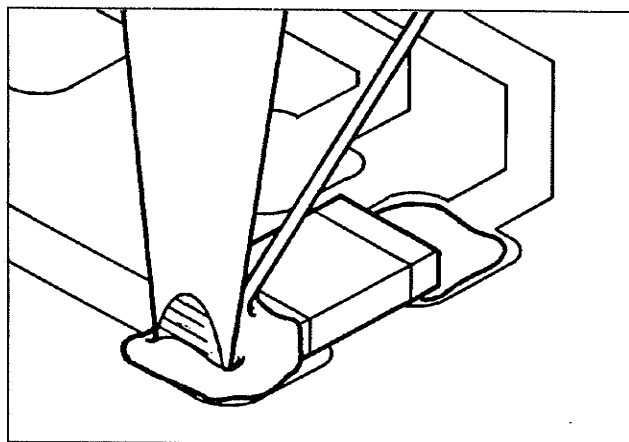

Figure 3 - 4

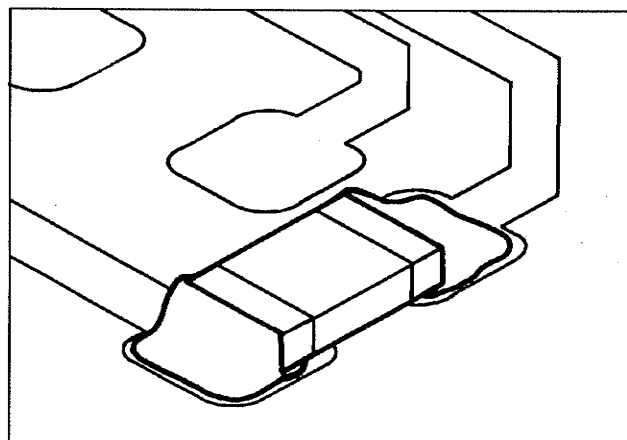

Figure 3 - 5

## REPLACING COMPONENTS WITH FEED-THROUGH LEADS

Exercise extreme care when replacing components with leads that feed through a PC board. The copper plating on both sides of the printed circuit board and inside component lead holes easily separates and tears from the PC board when heated.

Use a solder suction tool or braided desoldering-wick to remove solder from component leads, one at a time. Solder must be removed carefully and thoroughly so that the IC can be pulled without resistance. After removing as much solder as possible, use a dental pick or straight-pin to break the leads loose from the inside of the cleaned-out hole. Cutting the defective components away from its leads first makes removing the leads and solder easier.

Before installing a new component, remove all solder from lead holes and make sure the device is oriented properly. Always inspect old part leads for any feed-through plating rings that may have been pulled out of holes. The plating may have completed a circuit. If so, make sure the corresponding lead of the new component is soldered to plating runners on both sides of PC board as shown below.

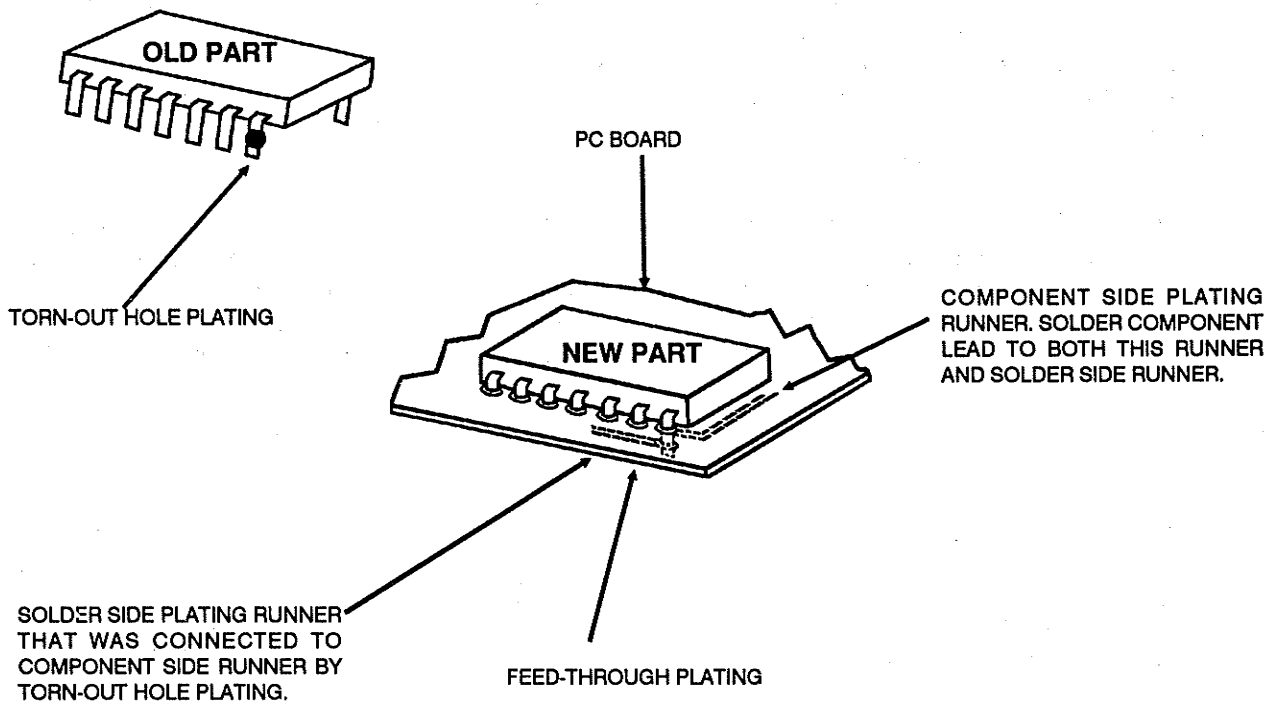

Figure 3 - 6

## ELIMINATING RADIO INTERFERENCE

Occasionally, you must contend with interference from somewhere in the automobile. Interference problems are solved by understanding the interference and its path into the transceiver, locating its source logically, then eliminating it in the simplest way available.

Interference may be conducted into the transceiver directly, or induced into it, or both. Conducted interference passes through the DC power leads or the accessory wiring of the radio. Radiated interference, which can originate from anywhere in the vehicle, simply produces noise voltages on conductors inside the radio or its antenna. See **Figure 3 - 7**.

Conducted interference is simple noise voltage present in the vehicle electrical system. With many electrical devices turning on and off in a vehicle, current spikes produce voltage drops across wire resistances, causing voltage transients to appear throughout the electrical system. Connecting the radio power leads to this noisy electrical system applies the noise voltage directly to the radio. Most noise voltage is attenuated by power-line filters within the radio; but spikes that are severe enough may become audible.

While interference conducted through power leads affects only transceiver audio circuitry, induced interference often invades the receiver through the antenna by imitating receiver IF frequencies or channel frequencies. Induced interference occurs when an electromagnetic field penetrates the radio. If an electromagnetic field is strong enough, it can induce noise currents on the radio accessory and power wiring.

### IDENTIFYING THE INTERFERENCE

The first step toward eliminating interference is to identify and characterize it. Listening to the noise can reveal a lot. For example: if the noise heard varies with engine speed, its source must relate to the engine, such as the alternator, ignition system, or tachometer.

Because you are dealing with frequency-modulated equipment, determining if the noise is at receiver-sensitive frequencies is easy. With all squelch circuits open, simply apply an unmodulated signal to the transceiver that is strong enough (10 mV at the

Antenna Jack) to overcome any high frequency noise signal that could invade below. If noise remains, interference is at low frequencies that can enter only by proximity coupling to radio wiring or direct conduction.

Next, power the radio with an independent 12 V power source (such as another car battery). Isolate by moving wiring and/or the radio while listening for changes in the noise level. If the noise stopped when you connected the independent power source, noise voltages are conducting through on the positive circuit or the ground (see **ELIMINATING CONDUCTED NOISE**).

### ELIMINATING CONDUCTED NOISE

If noise voltage is present on the power leads, there may be defective equipment in the vehicle electrical system that needs repair. An alternator with a bad diode has a large current ripple on its output, which produces a whine in the transceiver that varies in pitch with engine speed. Its current capacity is limited, but vehicle operation will not be noticeably impaired. Lights that dim during large current demands are a good sign of such a defect.

Another possible source of conducted interference is a fan motor in the same circuit to which the radio is connected. Because a fan also induces interference, confirm that noise is conducted into the radio (see **IDENTIFYING THE INTERFERENCE**). If the interference is conducted into the DC power leads of the radio, find a power connection point in the electrical system for the transceiver that is further from the fan circuit.

Noise voltages can also be added to the radio DC power input via the ground path. This is a condition where a high, noisy current shares the ground path of the radio equipment. For example:

Ground current of a fan motor finds its way to the vehicle battery through segments of metal body A-frame assemblies (see **Figure 3 - 8**). If the electrical bond between two parts is weak, and the radio ground current must also travel through this weak joint, a voltage drop induced across the joint by the fan current will appear at the radio power plug.

To avoid a noisy ground, connect radio ground closer to the vehicle battery.

ELECTROMAGNETIC RADIATION AT RECEIVER CHANNEL AND/OR I.F. FREQUENCIES

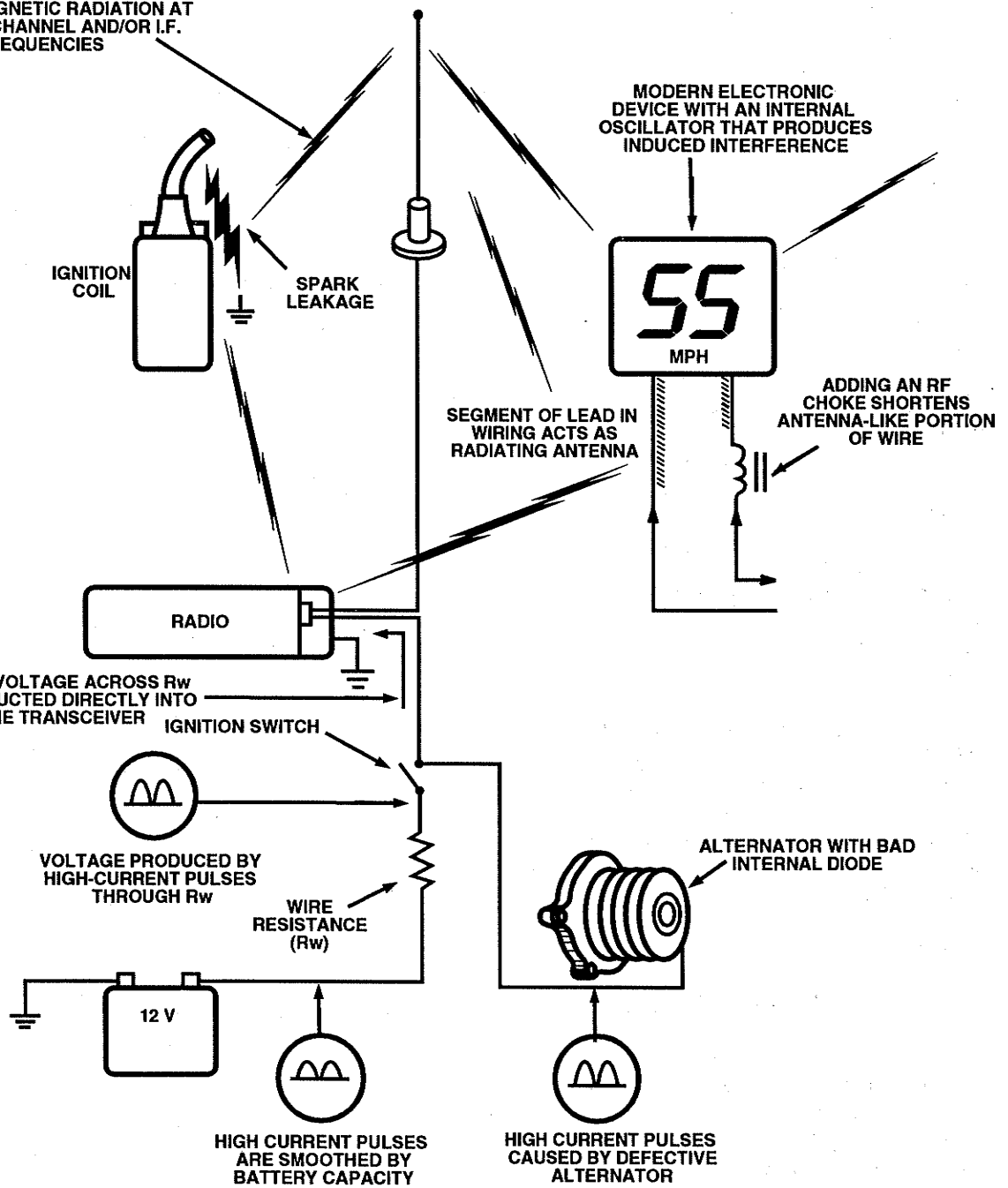

**Figure 3 - 7 — Interference Paths**



## ELIMINATING RADIATED INTERFERENCE

If DC power source substitution proves interference is not conducted into the power leads, two likely sources of radiated interference are sparks and high frequency oscillators. Modern vehicles use many electronic accessories and systems that may produce a hash or whine in the transceiver. Oscillators within these devices, which sometimes are poorly shielded, may radiate an electromagnetic field at frequencies many multiples of the oscillator frequency.

Again, listen to the noise to learn about its source. Unless the interfering automobile accessory is part of engine operation, the noise won't vary with engine speed. The interfering accessory can be isolated by temporarily removing power to it and checking for absence of noise.

Because the lead-in wires of an automobile device can become radiating antennas, induced interference is more often radiated from the automobile accessory wiring than the accessory itself. Such interference can be inductively coupled into nearby radio power and accessory wiring or radiated toward the antenna.

Check that the radio wiring does not run next to, nor parallel with, vehicle wiring. Move the wiring to identify and/or solve this problem.

If necessary, RF chokes can be connected in series with the "hot" lead-in wires of the interfering device, close to its housing to kill the antenna effect. Usually, "hot" wires can be identified if the noise volume changes with wire movement.

Radiated interference may also enter through the antenna. This can be verified by substituting the antenna and its cable with a 50  $\Omega$  RF dummy load and short cable. The dummy load is necessary to properly balance the receiver input and give comparable results. If the noise stops, interference was entering the antenna. The only way to solve this sort of interference problem is to eliminate radiation at the source with RF chokes as described above. Sometimes, positioning the antenna further from the interfering accessory may help.

## ELIMINATING INTERFERENCE FROM SPARKS

Sparks produce electromagnetic energy over a large area of the RF spectrum. This energy usually invades the receiver input through the antenna. Therefore, the problem must be resolved at the source.

Modern vehicles use higher voltage ignition systems. As a result, electrical leakage occurs more easily through cracks and contaminants. If the interference produces a buzz while the engine is idling, and the buzz increases in pitch with engine speed, sparks are leaking to ground before distribution to the spark-plug wires. Check the ignition coil, its high voltage wire, and distributor cap for signs of arcing through cracks and burns or over dirt.

If the interference produces a repetitive popping sound while the engine is idling, and it increases in rate with engine speed, a single spark plug or wire are suspect. Check the distributor cap, spark plug wires, and spark plugs for cracks, burns, and dirt.

Spark plug and ignition coil wires in modern vehicles are made with suppressive (resistive) conductors to reduce electromagnetic radiation. This may not be the case in older vehicles. Check with an ohmmeter.

Interference from sparks made by fan motor brushes produces a whine that varies with fan speed. Badly worn brushes or bearings cause excessive sparks, and you may need to replace them. A 0.1  $\mu$ F coaxial capacitor can be connected to the positive lead as close to the motor as practical to reduce radiated interference. The capacitor body must connect securely to the grounded motor housing.

# SERVICING

70-3400/3800

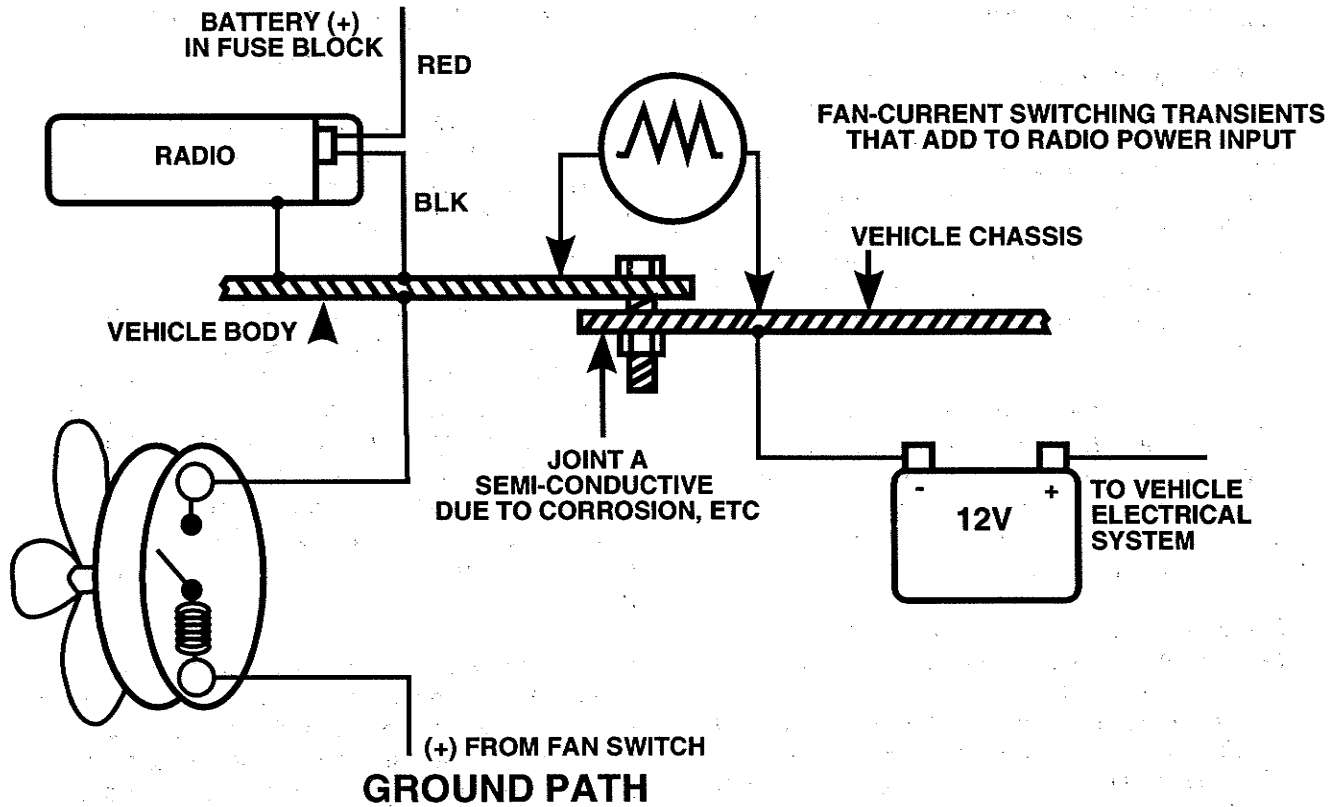

\*THIS FAN MODEL EXCLUDES IT'S INDUCTANCE WHICH WOULD MAGNIFY THE ILLUSTRATED EFFECT

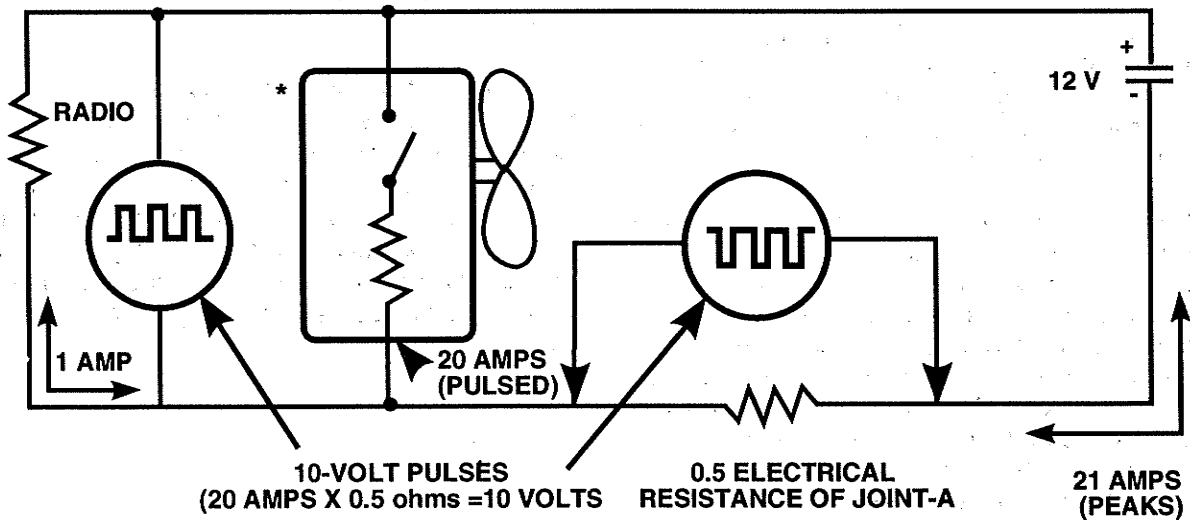

## EQUIVALENT CIRCUIT

Figure 3 - 8 — A Nolsy Ground

## VCO COVER REASSEMBLY

Certain attention to the VCO cover is required. The cover is a cast housing that is secured by six screws over the VCO circuitry in the RF Board. Located inside the cover is a rubber pad that applies pressure to the four VCO tuning coils, L702, L712, L722, and L732 (labeled RX-L, TX-L, RX-H, TX-H), to hold them solidly so they will not become microphonic.

When placing the VCO cover back onto the RF Board after repairs, its securing screws must be tightened in the pattern shown below to assure equal distribution of pressure on the tuning coils. Follow the numbers shown to sequentially tighten four of the six screws only a little each time, until all four screws are secure; then, tighten the last two.

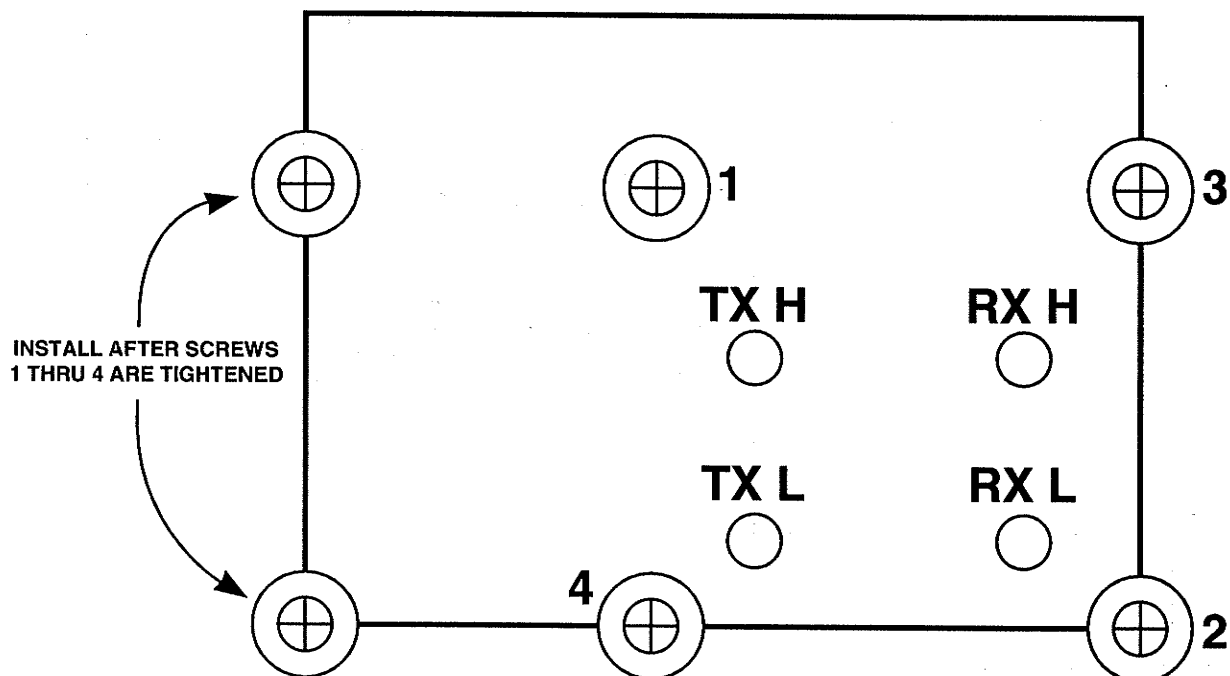

Figure 3 - 9 — Screw Tightening Pattern

**METERING**

The 70-3400 and the 70-3800 TX/RX Units contain a single block of metering pins for measurement of certain signals. This block, CM118, is a 6-pin, ribbon-plug receptacle. It is located on the RF Board next to the VCO cover and the synthesizer reference oscillator. Refer to **Table 3 - 1**.

PIN	NAME	MEASUREMENT
1	Ground	
2	Reference Oscillator Activity	A DC voltage that is produced by detection of IC102 reference-divider output that indicates existence of oscillator output. This metering voltage should be greater than 0.5 V.
3	VCO Steering	A DC voltage produced by the synthesizer phase-lock loop that controls resonance of the TX and RX VCO's. This metering voltage should be between 2.5 and 8.0 V DC when the loop is in lock; and varies with selected-channel frequency.
4	First-injection Level	A DC voltage produced by detection of first local-oscillator injection signal of the receiver, which is synthesized by the phase-lock loop. This metering voltage is used to optimize tuning of L222 and L223 and should be greater than 0.5 V.
5	Signal Strength	A DC voltage produced by detection of the 60 kHz bandpass-amplifier output in the noise-squelch circuit, which varies with on-channel RF signal level. Detected voltage subtracts from 8-V bias; therefore, metering voltage swings positive with RF signal increase.
6	Not used	

**NOTE:** Minimum voltmeter input impedance: 20,000  $\Omega$

A B C D E F G H I J K L M

1  
2  
3  
4  
5  
6  
7  
8

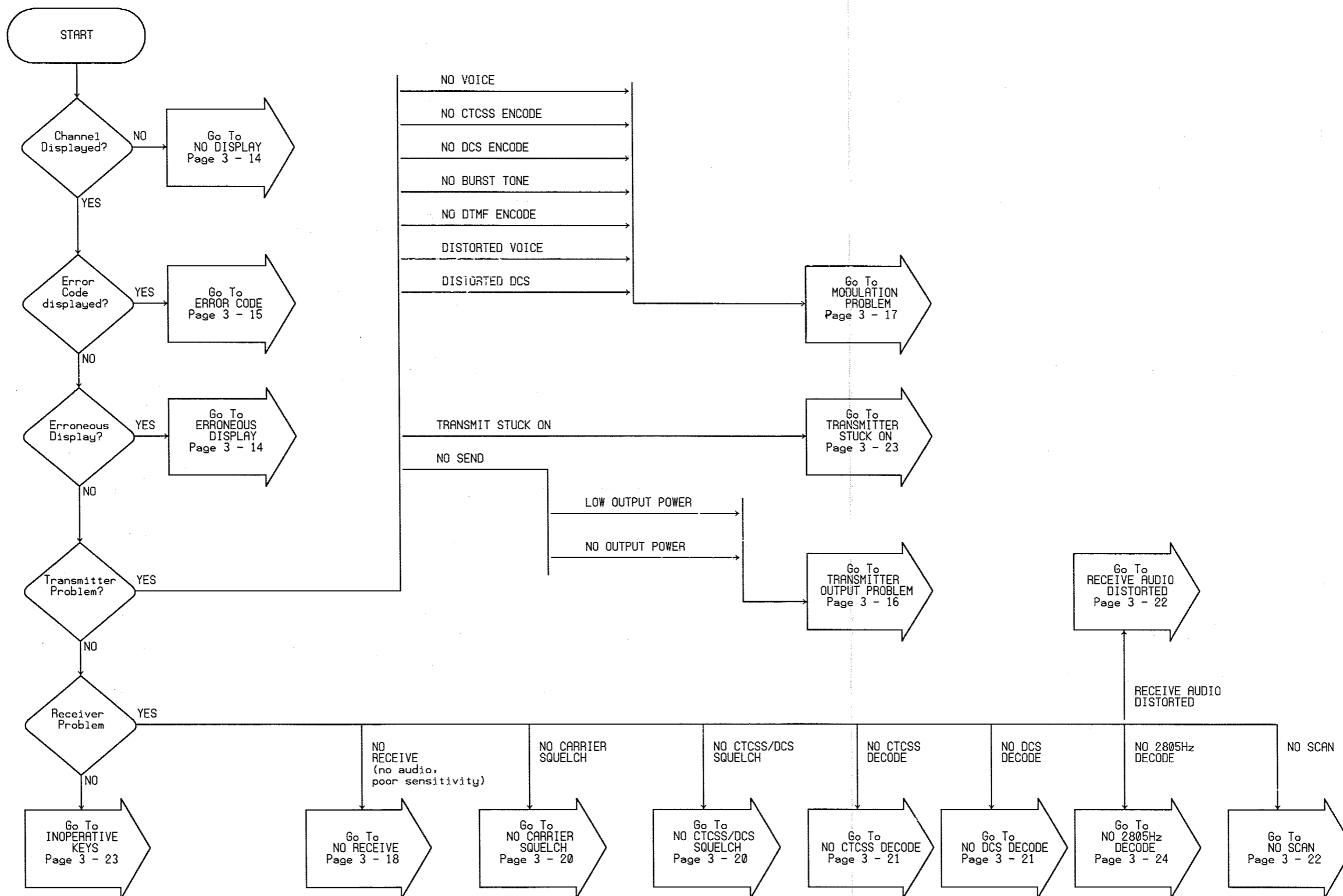

Troubleshooting Chart 3 - 1 — Getting Started

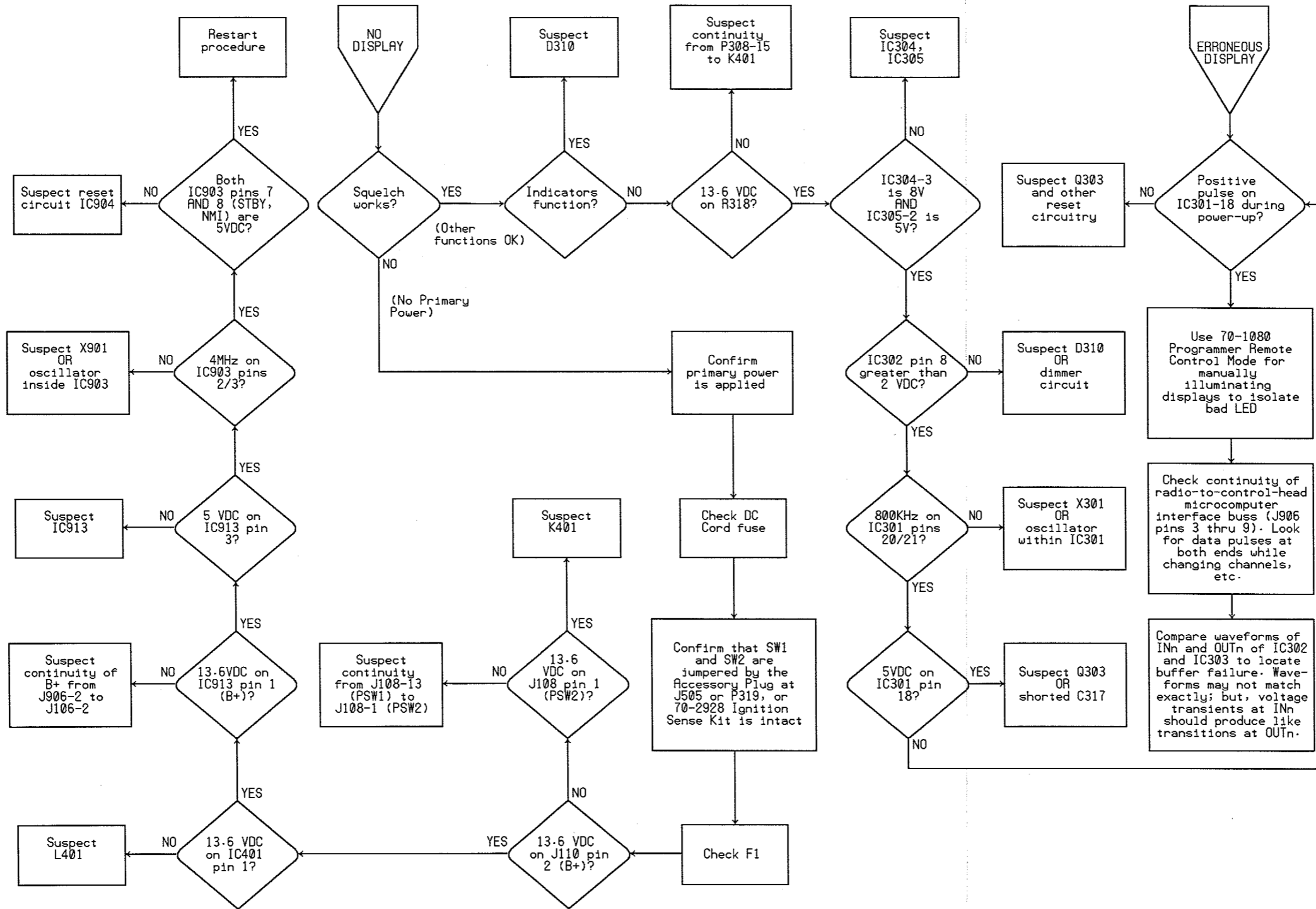

Troubleshooting Chart 3 - 2 — Display Problem

A B C D E F G H I J K L M

1  
2  
3  
4  
5  
6  
7  
8

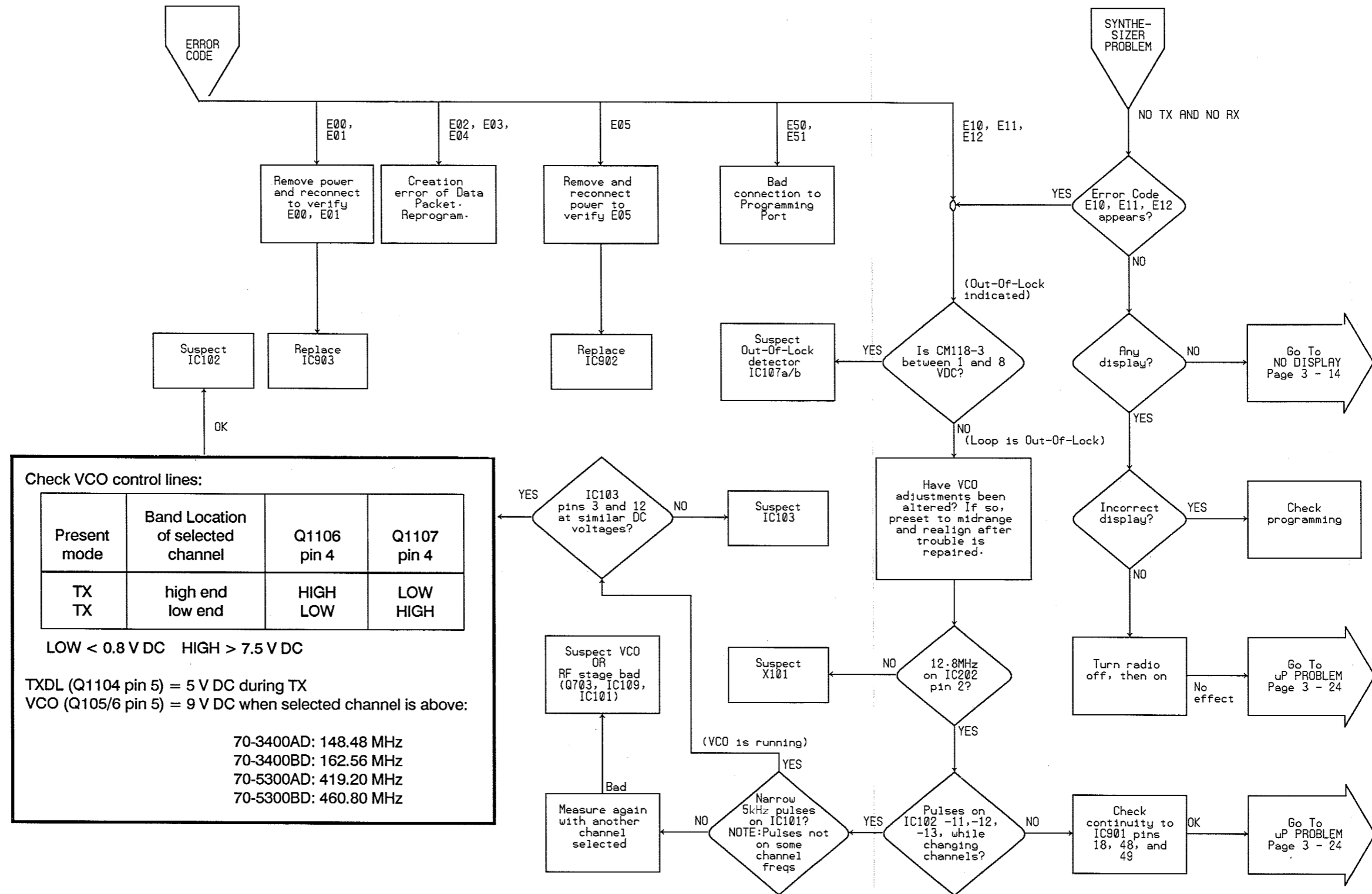

Troubleshooting Chart 3 - 3 — Error Code/Synthesizer Problem

1  
2  
3  
4  
5  
6  
7  
8

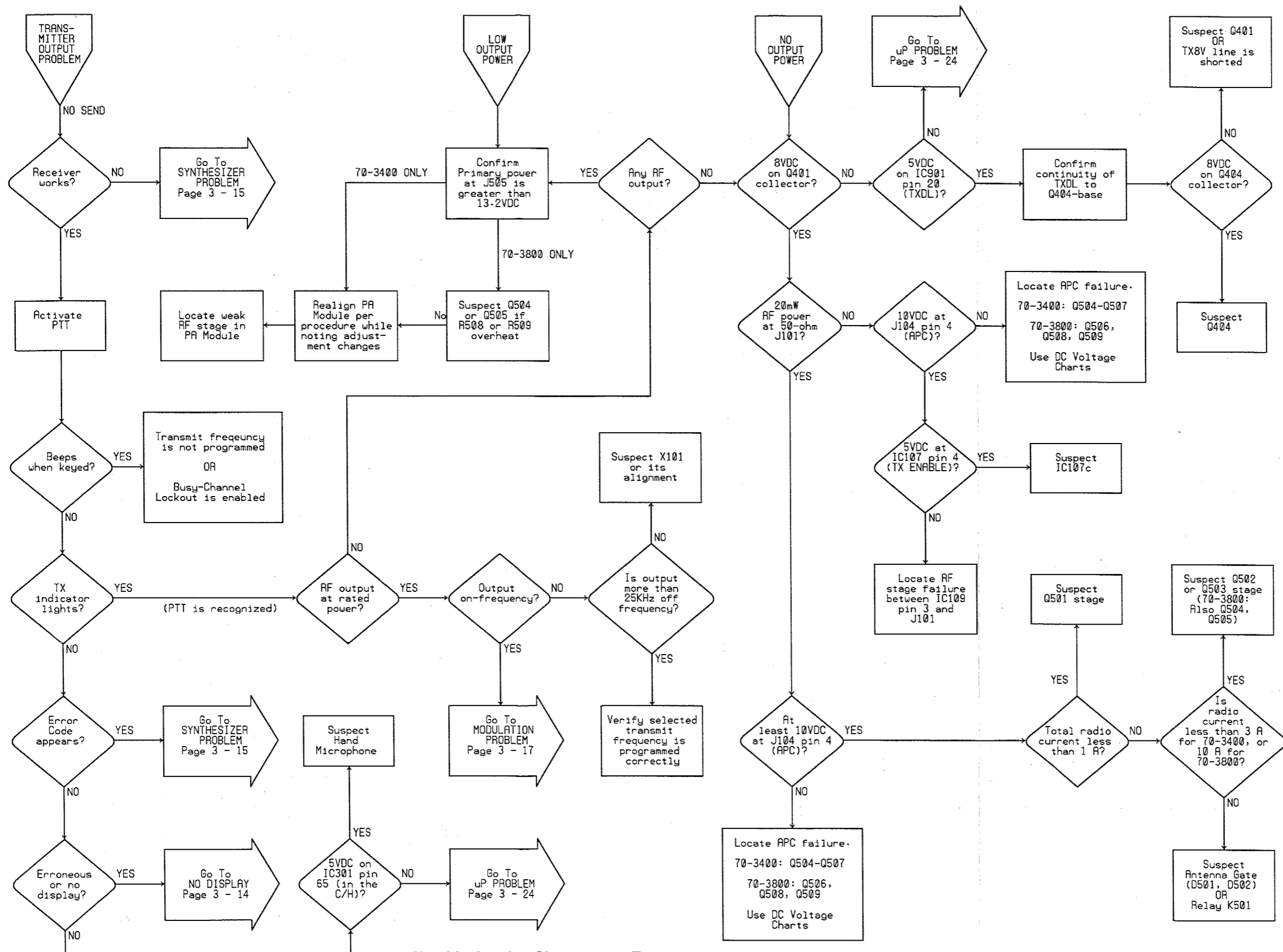

Troubleshooting Chart 3 - 4 — Transmitter Problem



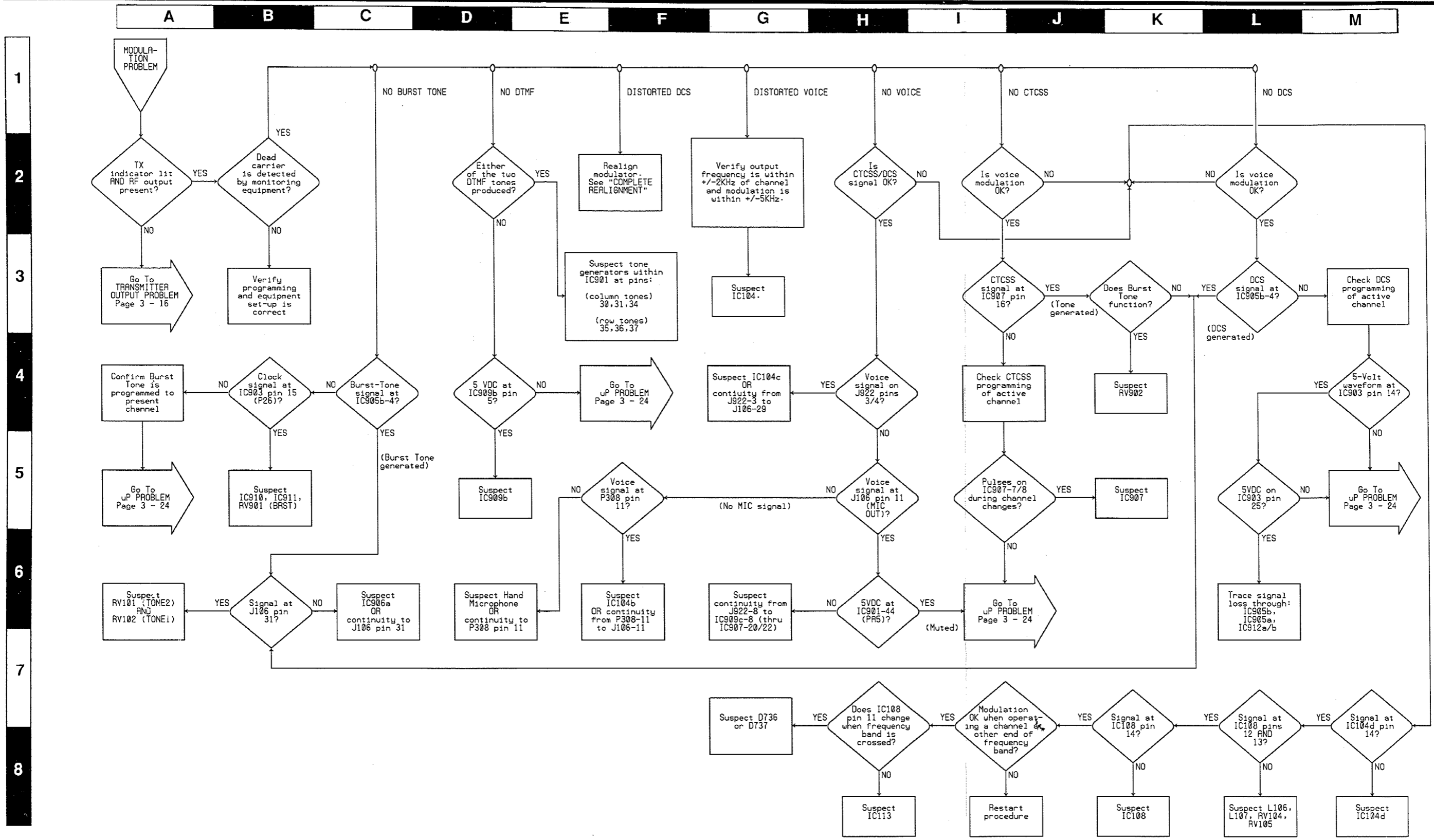

Troubleshooting Chart 3 - 5 — Modulation Problem

1  
2  
3  
4  
5  
6  
7  
8

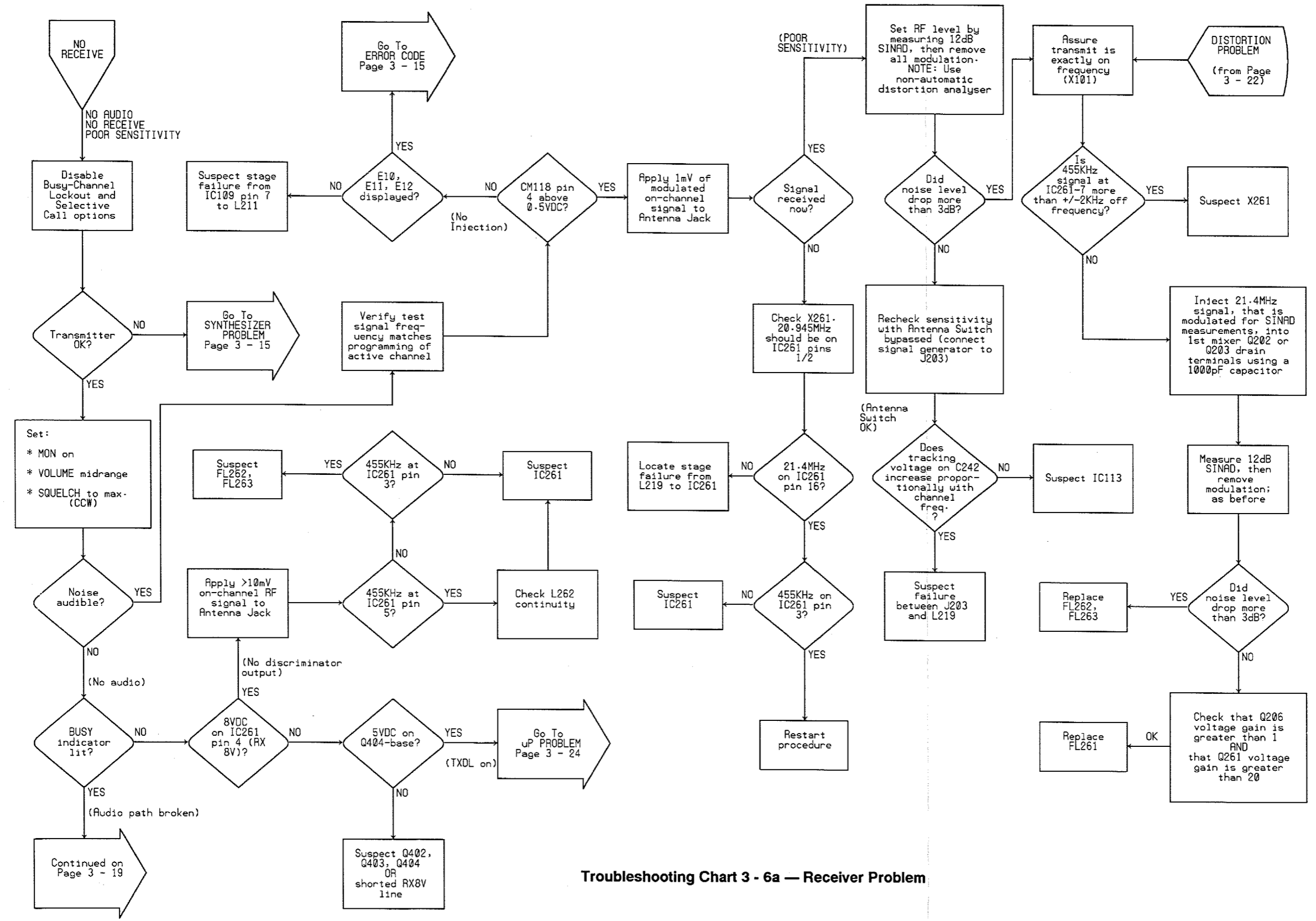

Troubleshooting Chart 3 - 6a — Receiver Problem

A B C D E F G H I J K L M

1  
2  
3  
4  
5  
6  
7  
8

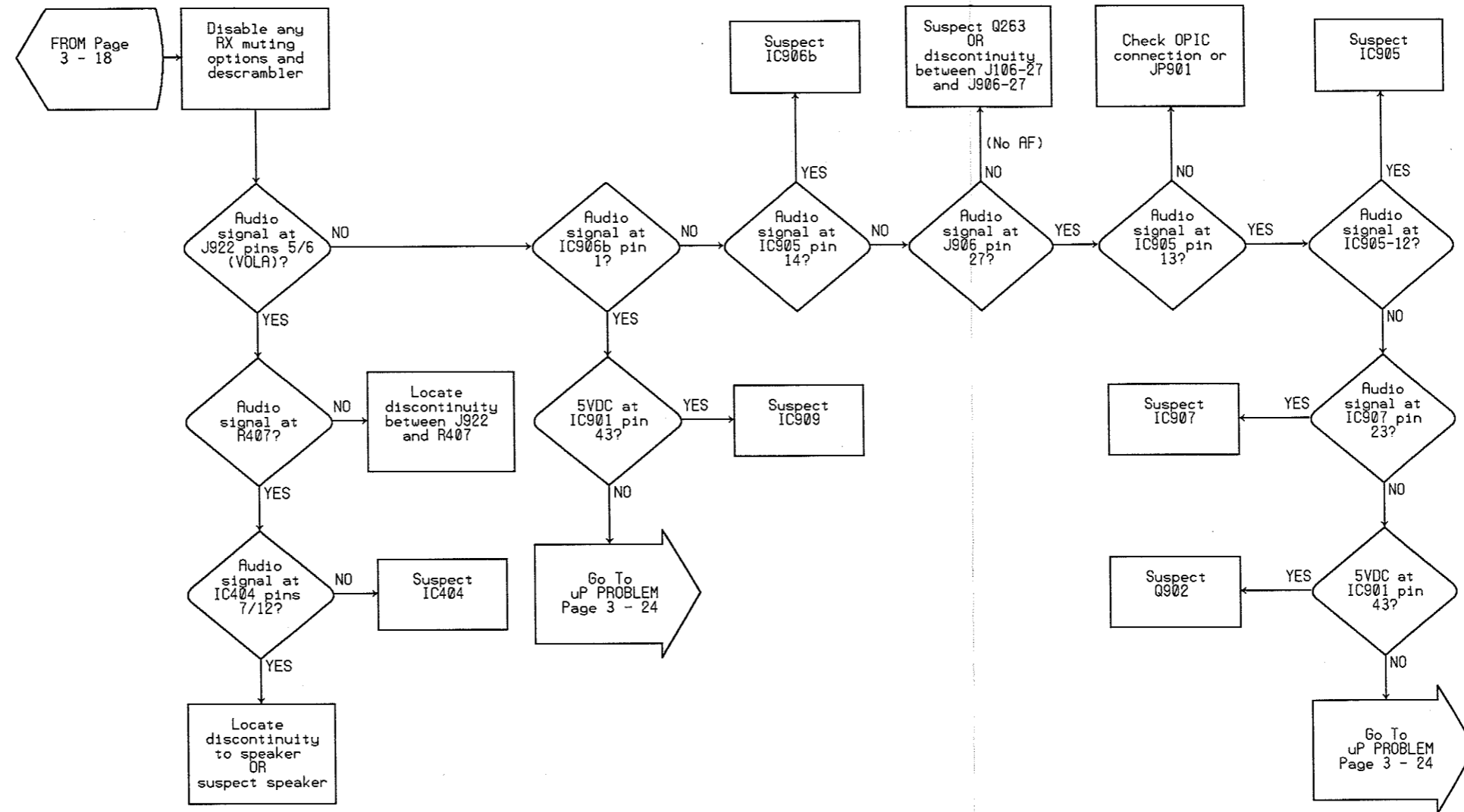

Troubleshooting Chart 3 - 6b — Receiver Problem (Continued)

1  
2  
3  
4  
5  
6  
7  
8

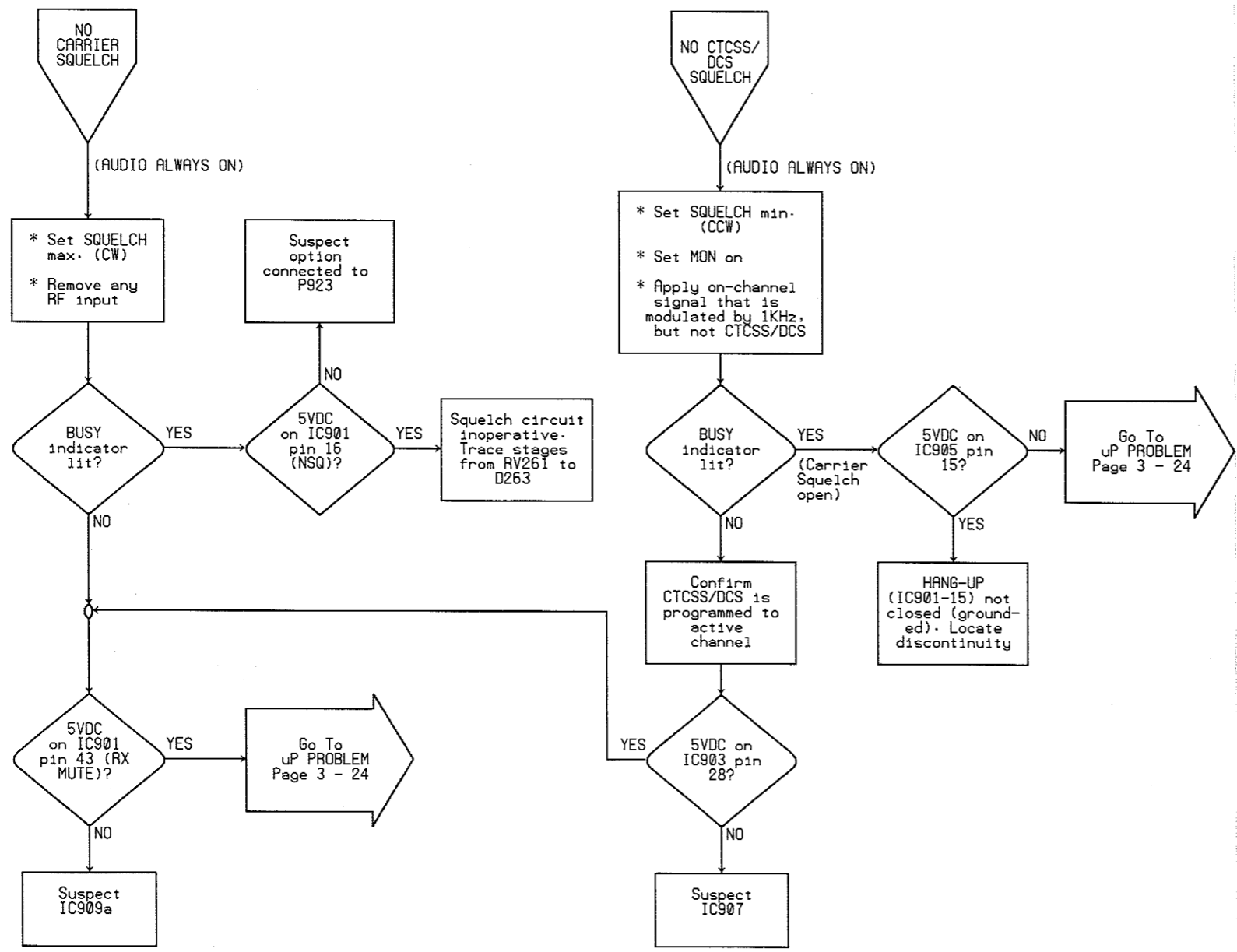

Troubleshooting Chart 3 - 7 — Squelch Problem

1  
2  
3  
4  
5  
6  
7  
8

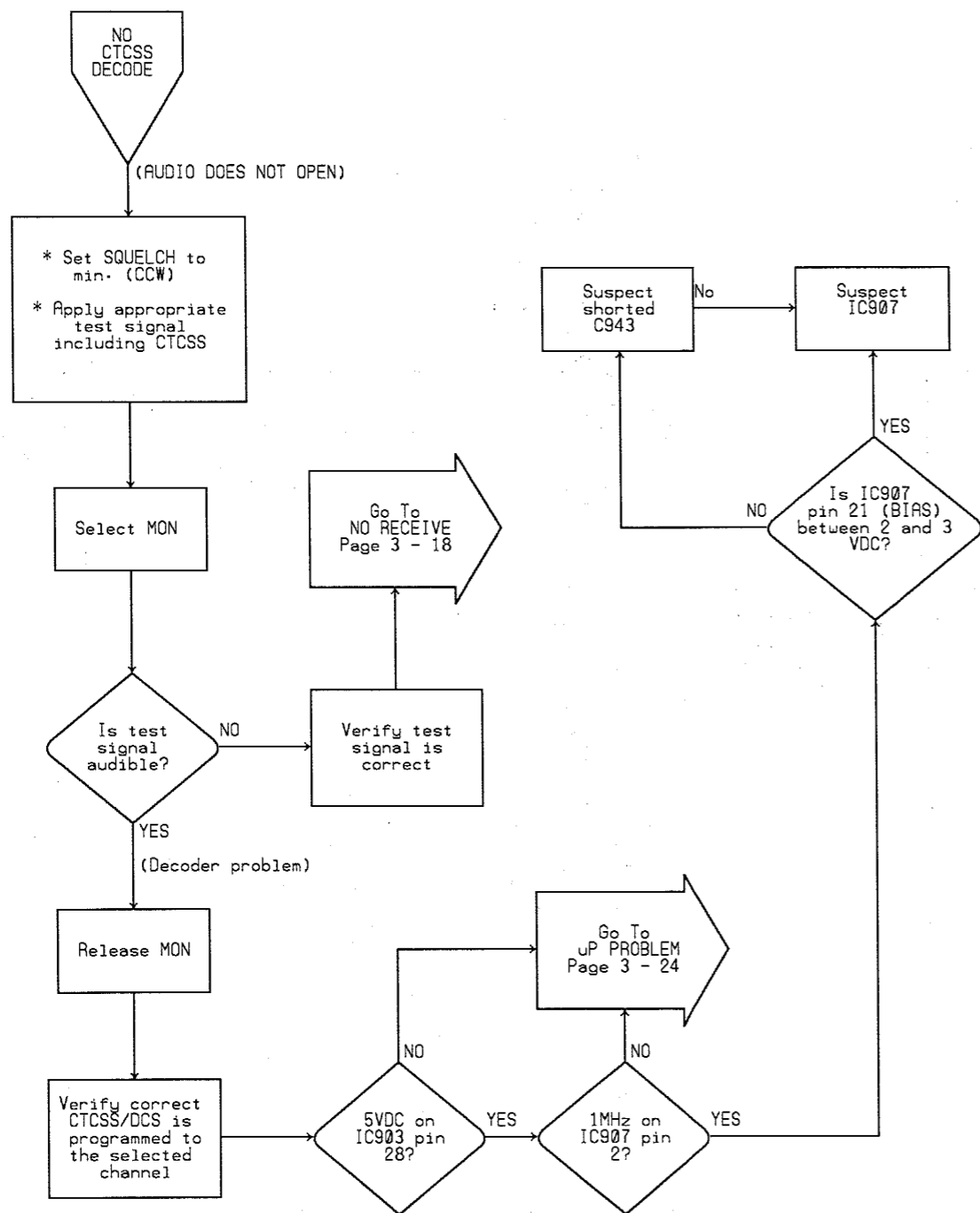

Troubleshooting Chart 3 - 8 — No CTCSS Decode

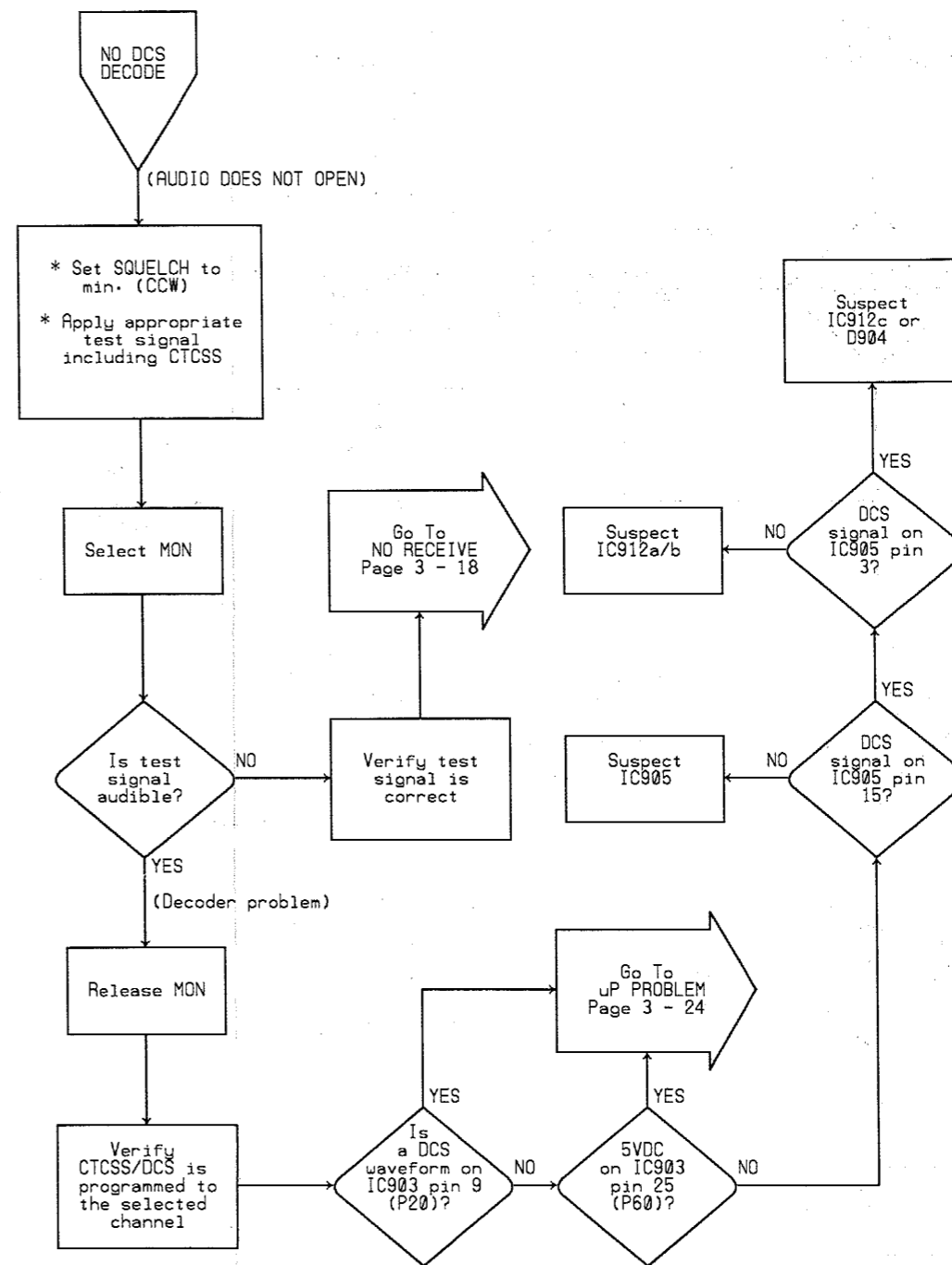

Troubleshooting Chart 3 - 9 — No DCS Decode

1  
2  
3  
4  
5  
6  
7  
8

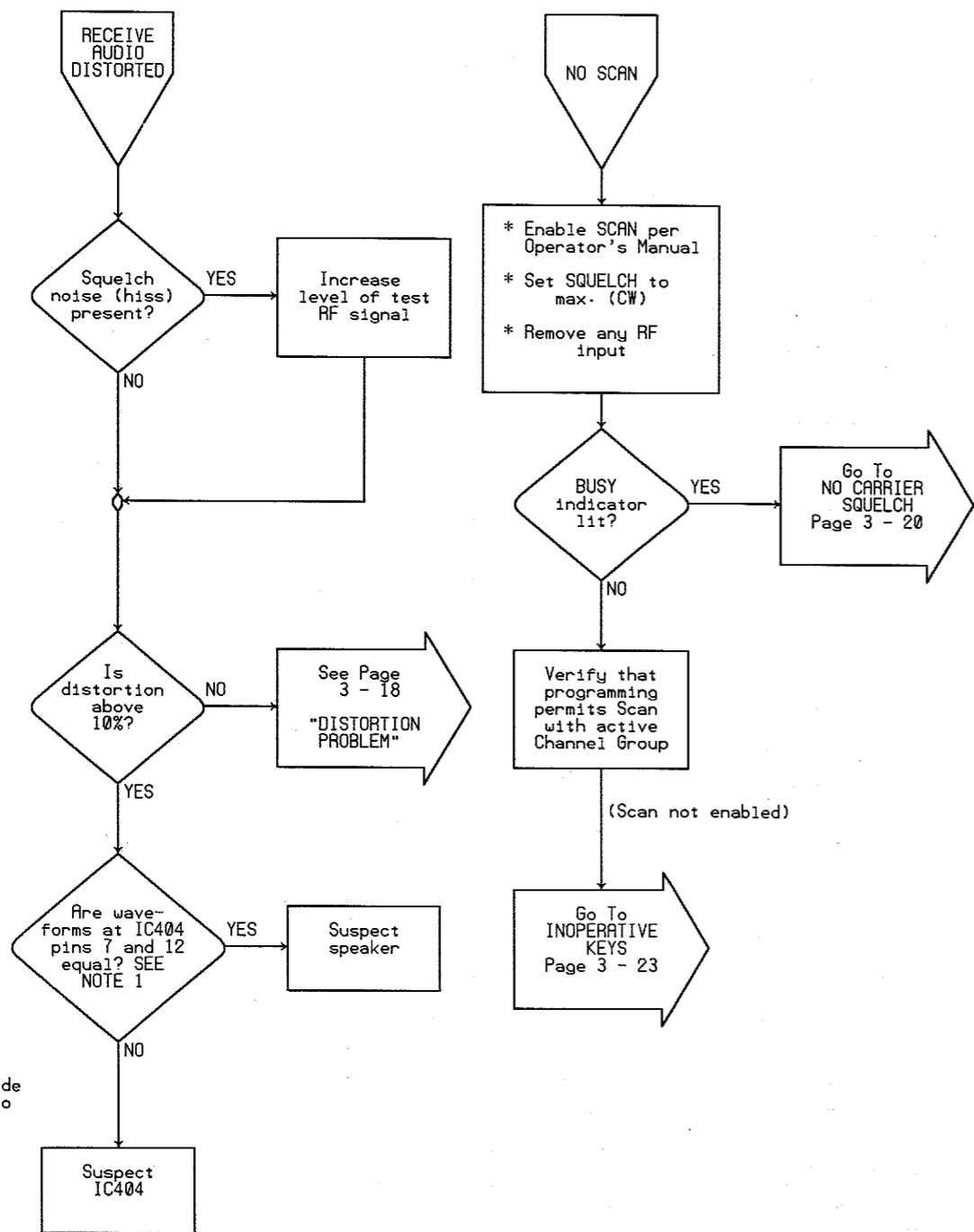

NOTE 1:  
Measure each side of speaker audio against ground.

Troubleshooting Chart 3 - 10 — Receive Audio Distorted

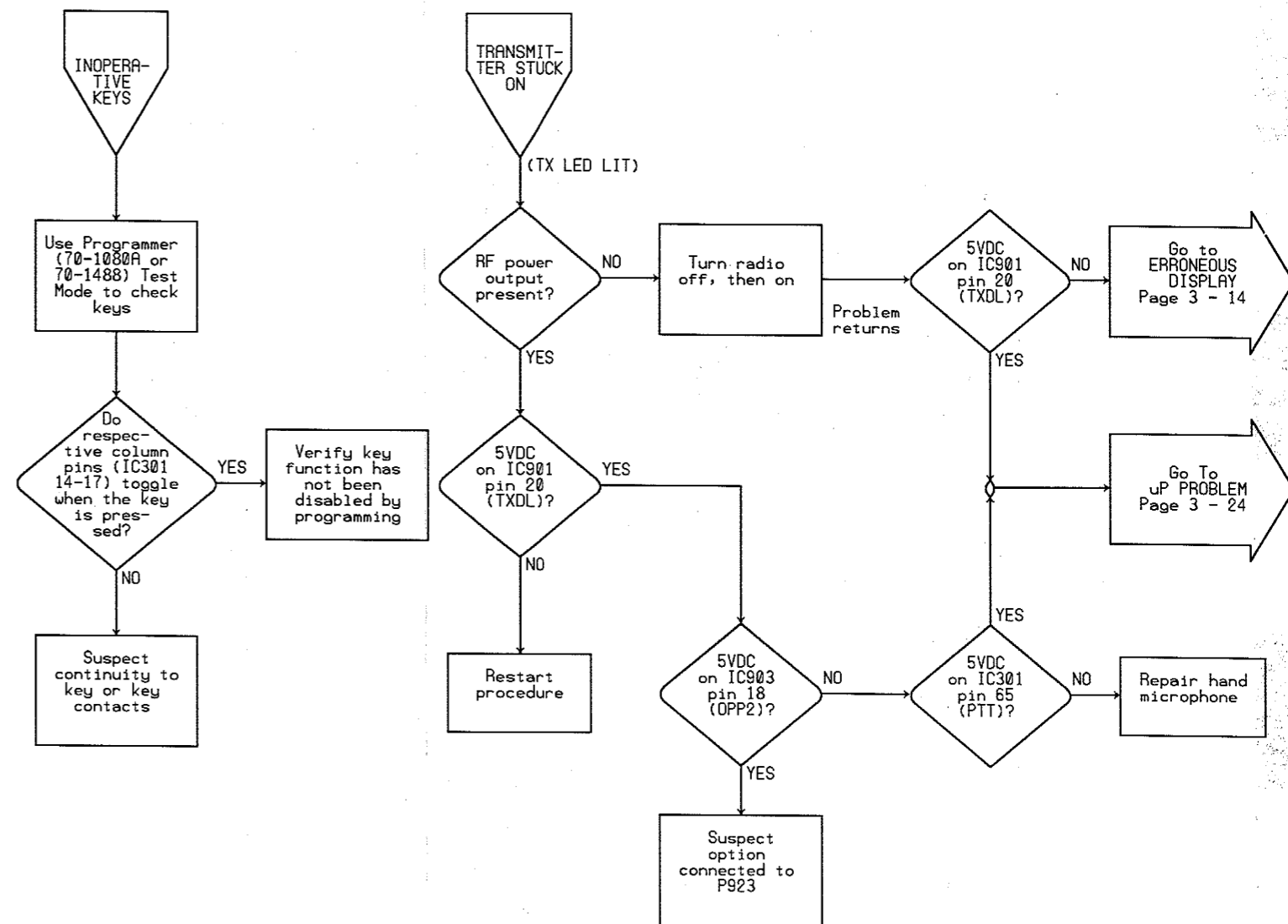

Troubleshooting Chart 3 - 11 — No Scan

1  
2  
3  
4  
5  
6  
7  
8

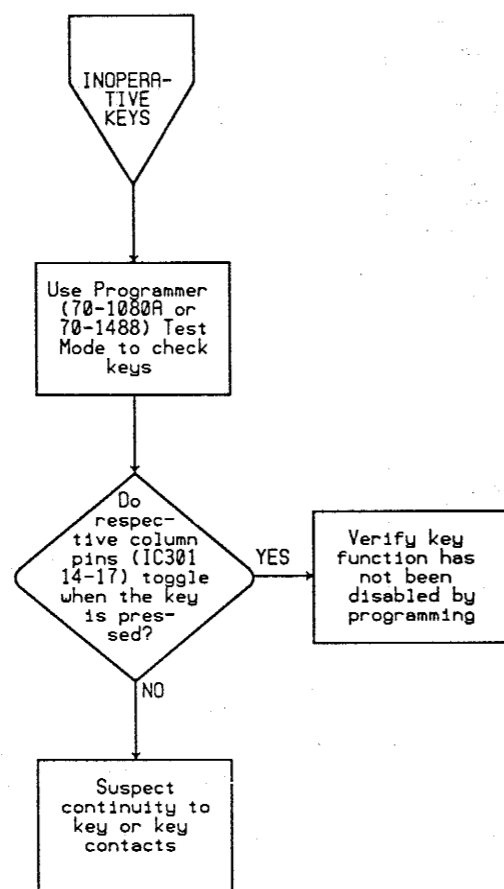

Troubleshooting Chart 3 - 12 — Inoperative Keys

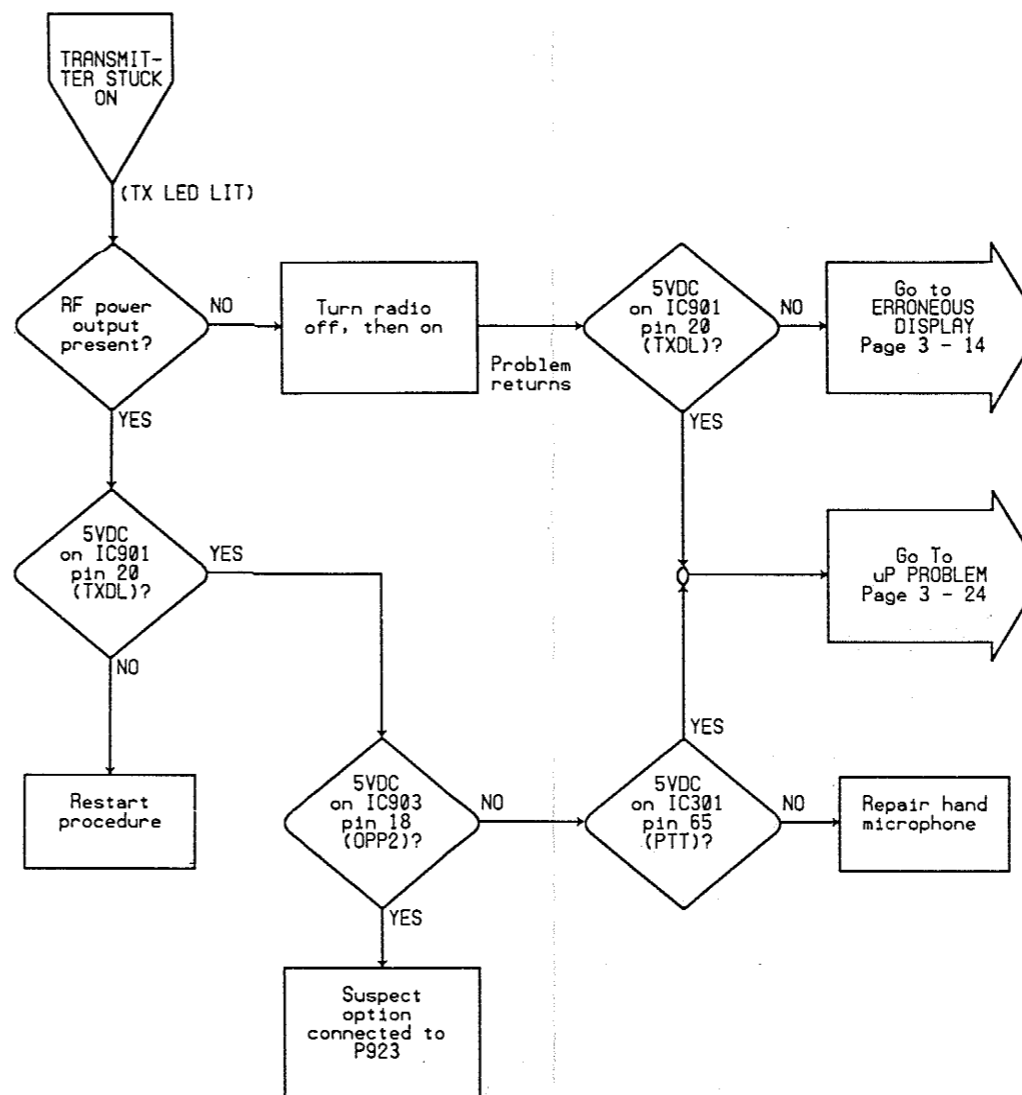

Troubleshooting Chart 3 - 13 — Transmitter Stuck On

1  
2  
3  
4  
5  
6  
7  
8

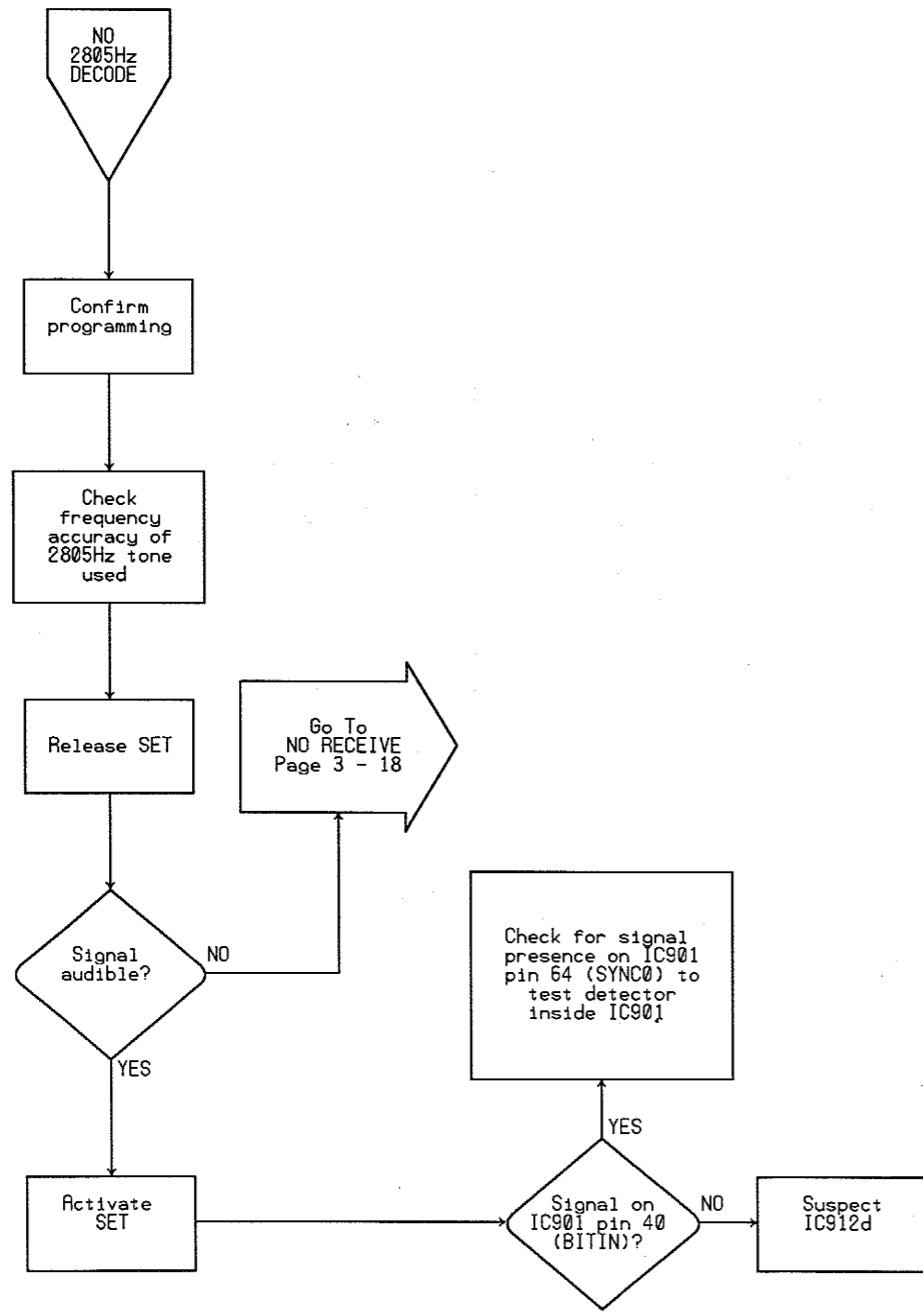

Troubleshooting Chart 3 - 14 — No 2805Hz Decode

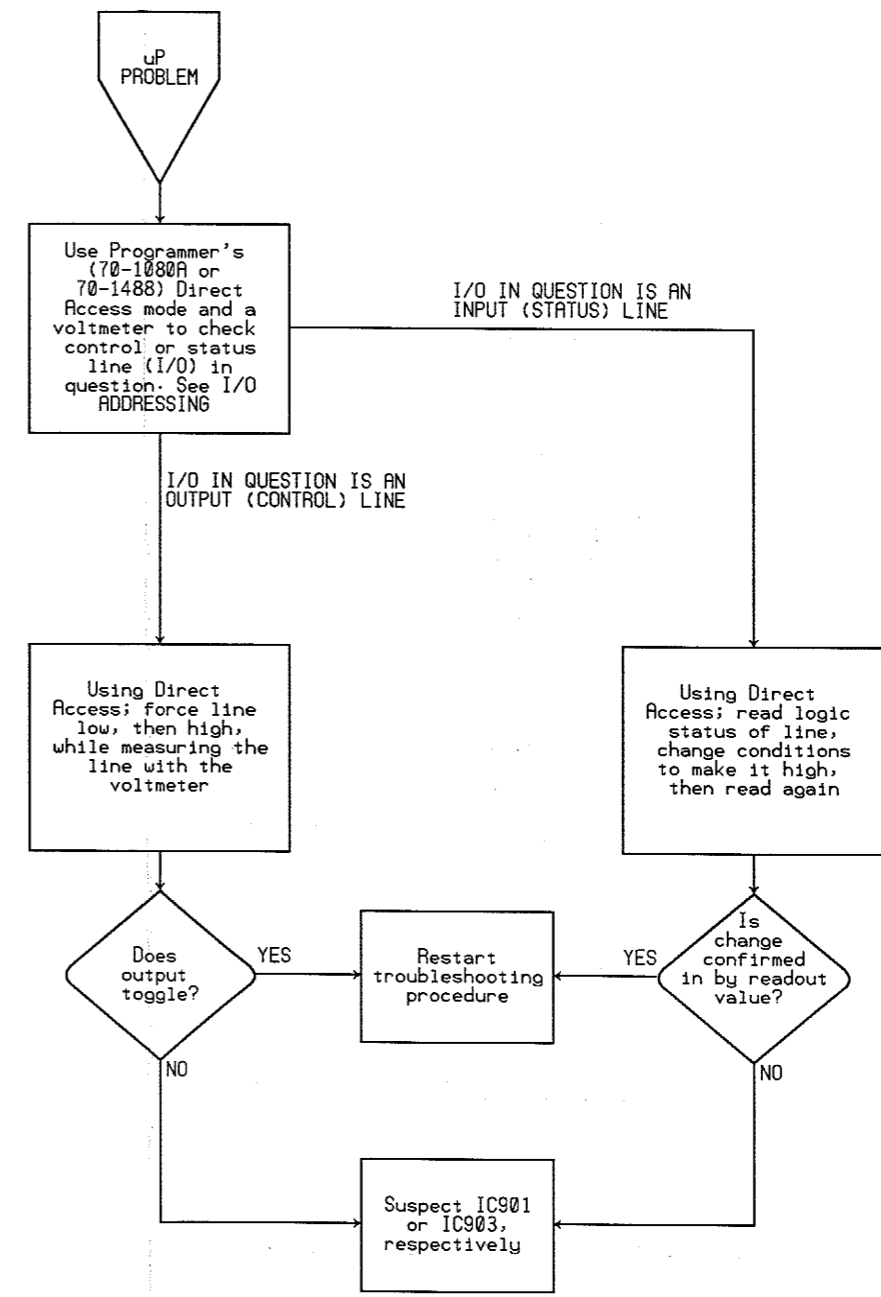

Troubleshooting Chart 3 - 15 — Microprocessor Problem



## I/O ADDRESSING

Please refer to the Troubleshooting Flow Charts, first. Due to the complications and confusions that can evolve when manipulating the microcomputer, only use I/O Addressing when troubleshooting process leads the failure to IC901 or IC903 ports.

Either the 70-1080A Programmer or 70-1488 PC Programming software is capable of manually controlling the microcomputer in the SYN-TECH II TX/RX Unit. This feature provides a valuable service tool; because, it is possible to verify microcomputer input/output port operation by bypassing microcomputer software and switching outputs at will, or reading inputs. For example: if you set port PB2 to "1", IC901-20 should measure 5 V. If not, you can conclude that internal port circuitry within IC901 is defective and IC901 needs to be replaced.

### A LITTLE BACKGROUND

The TX/RX Unit microcomputer, like most digital microcomputers, is comprised of a long column of data units. Each unit contains eight binary pieces of information (**bits**) in the form ones and zeros that represent electrical logic lows of nearly 0 V and logic highs of approximately 5 V, respectively. Each data unit, called a **byte**, has its own sequential numeric address in the column, so that it can be selected by the microprocessor. The entire column, with its addresses, is known as the **memory map**.

Byte locations in the column of bytes take different physical forms: some are read + write temporary storage locations (RAM); some are read-only locations filled with computer instructions (ROM); some are input ports where each bit is a radio status line, such as noise-squelch detector output (NSQ); some are output ports where each bit is applied to a radio control line, such as transmitter enable (TXDL). All these locations types are assembled using IC901, IC902, and IC903. Inside IC903 is a microprocessor that shuffles bytes from one location to another as dictated by the computer instructions in ROM. The microprocessor can also modify the byte on the way. Propelled by a 4 MHz clock, the processor's byte shuffling activity can produce useful results; like operating a two-way radio.

**Hexadecimals** are alphanumeric representations of half-bytes. Two hexadecimal numerals denote

one byte, which contains eight bits. Each bit value (one or zero) can be determined from the hexadecimal designators as follows.

BYTE 1 0 0 1 1 1 0 0 = 9C

x8 x4 x2 x1    x8 x4 x2 x1

8 + 0 + 0 + 1    8 + 4 + 0 + 0

9

C

### DIRECT ACCESS

Either the 70-1080A Programmer or 70-1488 PC Programming software is needed to manipulate SYN-TECH II I/O ports and the Direct Access function of the Programmer Remote Control Mode is used. Under Direct Access Remote Control, normal TX/RX Unit microcomputer operation is frozen and data within any byte location can be read or written to.

Refer to the appropriate Operator's Manual for instructions on how to connect the Programmer and initiate the Remote Control Mode, and how to operate the Direct Access function. Because it is possible to permanently lose radio programming while using the Direct Access function, ALWAYS upload the radio Data Packet into the Programmers memory BEFORE initiating the Remote Control Mode.

To troubleshoot an input port, the port is addressed using Direct Access, and its data byte (in hexadecimal) is read on the Programmer display. Depending on the byte value, the logic level on a specific status line can be determined mathematically. If the answer does not match voltmeter measurements, defective port circuitry is suspect. To troubleshoot an output port, the port is again addressed, then a byte is written to it. The value of the byte determines which control lines will be logic high. Again, voltmeter measurement locates a defect.

There are seven input and output ports that interface to the radio. Each port encompasses eight pinouts; some of which may not be used. When manipulating or reading a port, all eight pins are affected at once by one byte of information. Procedures herein detail specific I/O port access. Please follow these procedures to assure correct results.

# SERVICING

70-3400/3800

**RESETTING DIRECT ACCESS:** If a problem arises while using Direct Access, a hard-reset is the best way out. A hard-reset is accomplished by removing all DC power (13.6 V DC) from the radio for at least 10 seconds, and turning the Programmer off, then on. If the radio is equipped with the 70-2925 Memory Back-up Kit (a large capacitor clamped and wired to the Logic Board), you must also momentarily short the black and red wires of the supercapacitor while the radio power is disconnected.

## • IC901 — PORT A (PAx), Outputs Only

- Using the Programmer's Direct Access mode, enter this address: 5000 (hex), then press ENT. "5000" appears under the letters "ADS" and "00" appears under the letters "DATA" in the Programmer display.
- If you wish to output a logic high from a specific Port-A line, find the corresponding byte in the HIGH column of **Table 3 - 1**, and enter its two hexadecimal digits into the Programmer. Press ENT. A short beep will sound. If you wish to output a logic low instead, choose the corresponding byte in the LOW column to enter. The bytes in the chart are designed to switch the selected line, only; and leave the rest unchanged.
- When finished, disconnect the Programmer and turn it off. Disconnect the radio from its 13.6-V power source for at least ten seconds. If the radio is equipped with the 70-2925 Memory Back-up Kit, short the terminals of the supercapacitor while radio power is disconnected.

The selected control line should be at the selected logic voltage. If not, the output may be defective.

**Table 3 - 1 — IC901 Port A**

PAx BIT	IC901 PIN NO.	FUNCTION	BYTE TO BE ENTERED FOR	
			HIGH	LOW
0	49	CHDT - RF Board data	81	80
1	48	DCLK - RF Board data clock	82	80
2	47	DCL - HI= C/H data direction: to C/H	84	80
3	46	P. A. CNTL - HI= pub. add. gate enable	88	80
4	45	P. A. SW - HI= public address relay on	90	80
5	44	TX MUTE - LO= mute microphone audio	A0	80
6	43	RX MUTE - LO= mute receive audio	C0	80
7	42	RX PATH - HI= RX audio bypass IC907	80	00

## • IC901 — PORT B (PBx), Outputs Only

- Using the Programmer's Direct Access mode, enter this address: 5002 (hex), then press ENT. "5002" appears under the letters "ADS" and "96" appears under the letters "DATA" in the Programmer display.
- If you wish to output a logic high from a Port A line, find the appropriate byte in the HIGH column of the chart below, and enter its two hexadecimal digits into the Programmer. Press ENT. A short beep will sound. If you wish to output a logic low instead, choose the appropriate byte in the LOW column of **Table 3 - 2**, to enter. The bytes in the chart are designed to switch the selected line, only; and leave the rest unchanged.
- When finished, disconnect the Programmer and turn it off. Disconnect the radio from its 13.6-V power source for at least ten seconds. If the radio is equipped with the 70-2925 Memory Back-up Kit, short the terminals of the supercapacitor while radio power is disconnected.

The selected control line should be at the selected logic voltage. If not, the output may be defective.

Table 3 - 2 — IC901 Port B

PBx BIT	IC901 PIN NO.	FUNCTION	BYTE TO BE ENTERED FOR	
			HIGH	LOW
0	18	DSTB1 - LO= latch RF Board data	63	62
1	19	LPSW1 - LO= speed PLL lock time	63	61
2	20	TXDL1 - HI= transmitter circuits on	67	63
3	21	not used		
4	22	HORN SW - HI= horn switch is on	73	63
5	23	DSTB2 - LO= latch opt. 2nd PLL data	63	43
6	24	LPSW2 - LO= speed 2nd PLL lock time	63	23
7	25	TXDL2 - HI= 2nd TX'er circuits on	E3	63

• IC901 — PORT C (PCx), Inputs Only

1. Set up the radio as follows. This assures that the bytes read from the port will be the same values shown in Table 3 - 3. If these items are not set as shown, you may need to do additional hexadecimal-to-binary conversion to determine the logic status of the port in question.
  - a. Set the SQUELCH control to maximum (clockwise).
  - b. Place a jumper between pins 2 and 3 of Accessory Jack J505 on the TX/RX Unit. If the radio is an under-dash configuration (70-342x or 70-385x), either a jumper or a Hang-Up box (which must be closed) is already in place.
  - c. If the radio is a trunk-mount configuration, also remove the jumper between pins 2 and 3 of Accessory Jack J319 (or open the Hang-Up Box).
  - d. Disconnect the antenna so that no carrier is received.
2. Using the Programmer, enter this address: 5002 (hex), then press ENT. "5002" appears under the letters "ADS" and a two-character hexadecimal designator appears under the letters "DATA" in the Programmer display.
3. The DATA designator indicates the status of the logic voltages applied to the eight Port-C inputs. The hexadecimal value can be deciphered as follows:
4. When finished, disconnect the Programmer and turn it off. Disconnect the radio from its 13.6-V power source for at least ten seconds. If the radio is equipped with the 70-2925 Memory Back-up Kit, short the terminals of the supercapacitor while radio power is disconnected.

Table 3 - 3 — IC901 Port C

PCx BIT	IC901 PIN NO.	FUNCTION	BYTE VALUE IF PCx IS	
			HIGH	LOW
0	9	HI= 2805 Hz tone is detected	97	96
1	10	not used		
2	11	not used		
3	13	THSW - HI= PA Module is overheated	9E	96
4	14	C/H HANGUP -HI= U/D or J319-3 is gnd	96	86
5	15	T/R HANGUP - LO= J505-3 is grounded	B6	96
6	16	NSQ - HI= rcvr is quieted by carrier	D6	96
7	17	not used		

## SERVICING

70-3400/3800

### • IC901 — PORT D (PDx), Inputs and Outputs

This entire port is used as a communications buss between the Control Head microcomputer and the TX/RX Unit microcomputer. Manual control of these lines is complicated and troubleshooting by exchanging control heads is easier. Therefore, I/O-Port-D Manipulation instructions are not provided.

### • IC903 — PORT 2 (P2x), Input/Output

Many of the lines from this port are used to communicate to the Programmer; therefore, manipulation of those lines is impossible and manipulation any Port-2 line is precarious — an incorrect entry may lockup the Programmer or radio. A hard-reset would then be required.

#### Reading Port P20

(IC903-9, Recovered DCS Input):

1. Using the Programmer's Direct Access mode, enter this address: 0003 (hex), then press ENT. "0003" appears under the letters "ADS" and a two-digit hexadecimal designator appears under the letters "DATA" in the Programmer display.
2. If the DATA value is odd, voltage on P20 was at a logic high when the port was read; if even, P20 was low. **NOTE:** Squelch noise applies random logic lows and highs to this port; therefore, if Port 20 is functioning correctly, odd and even values should be extracted at least once each during several readings of this port.
3. When finished, disconnect the Programmer and turn it off. Disconnect the radio from its 13.6-V power source for at least ten seconds. If the radio is equipped with the 70-2925 Memory Back-up Kit, short the terminals of the supercapacitor while radio power is disconnected.

#### Writing to Port P25

(IC903-14, DCS Encode Output):

1. While the radio is under remote control, this line is programmed as an input and voltage on

it will be the 2.5 V bias as established by IC907 pin 21. Because other Port 2 lines are used to communicate to the Programmer, P25 cannot be set and held. You can only temporarily reprogram this line to be an output, in which case it will only apply a logic high; but, P25 will change back to an input as soon as you change Direct Access to another byte location.

2. Using the Programmer's Direct Access mode, enter this address: 0001, then press ENT. "0001" appears under the letters "ADS" and a two-digit hexadecimal designator appears under the letters "DATA" in the Programmer display.
3. Enter F2, then press ENT. This will set P25 to logic high until you enter another address.
4. When finished, disconnect the Programmer and turn it off. Disconnect the radio from its 13.6-V power source for at least ten seconds. If the radio is equipped with the 70-2925 Memory Back-up Kit, short the terminals of the supercapacitor while radio power is disconnected.

#### Writing to Port P26

(IC903-15, Burst-Tone Clock Output):

1. Using the Programmer's Direct Access mode, enter this address: 0003, then press ENT. "0003" appears under the letters "ADS" and a two-digit hexadecimal designator appears under the letters "DATA" in the Programmer display.
2. If you wish to output a logic high from P26; enter 78, then press ENT. If you wish to output a logic low, enter 38, then press ENT.
3. When finished, disconnect the Programmer and turn it off. Disconnect the radio from its 13.6-V power source for at least ten seconds. If the radio is equipped with the 70-2925 Memory Back-up Kit, short the terminals of the supercapacitor while radio power is disconnected.

**IC903 — PORT 5 (P5x), OPP Inputs/Outputs**

Each line of this port can be an input or an output, as determined by the value written to the direction register located at address 0020 (hex).

1. Disconnect any options that may be connected to P923.
2. Reprogram the Option Port Type parameter of the radio Data Packet for 0 (NONE), if necessary. You should already have the Data Packet stored in the Programmer, so simply change the Option parameter (see Programmer Operator's Manual) to 0 and download the Data Packet back into the radio. Then initiate Remote Control Mode.
3. All Port 5 lines will be unterminated; therefore, they will read as logic low (0). To test an input, it is necessary to apply a logic high (5 V) to the I/O line in question using a 1,000-Ω resistor from P923 pin 2. Leave the others unterminated.

**Input Test:**

4. Using the Programmer, enter this address: 0020, then press ENT. "0020" appears under the letters "ADS" and a two-digit hexadecimal designator appears under the letters "DATA" in the Programmer display.
5. Enter 00, then press ENT. This sets all Port-5 lines to input mode.
6. Press MNL, then enter this address: 0015 (hex). Press ENT. "0015" appears under the letters "ADS" and a two-digit hexadecimal designator appears under the letters "DATA" in the Programmer display. Refer to the table below to decode the status of the lines:

If	OPP1 (P50, IC903-17)	is high,	DATA will be	09
"	OPP2 (P51, IC903-18)	"	"	0A
"	OPP3 (P52, IC903-19)	"	"	0C
"	OPP4 (P54, IC903-21)	"	"	18
"	OPP5 (P55, IC903-22)	"	"	28
"	OPP6 (P56, IC903-23)	"	"	48
"	OPP7 (P57, IC903-24)	"	"	88

**Output Test:**

7. Press MNL, then enter this address: 0020 (hex). Press ENT. "0020" appears under the letters "ADS" and a two-digit hexadecimal designator appears under the letters "DATA" in the Programmer display.
8. Enter F7, then press ENT. This sets all OPP lines to output mode (P53 of IC903 must remain an input).
9. Press MNL, then enter this address: 0015 (hex). Press ENT. "0015" appears under the letters "ADS" and a two-digit hexadecimal designator appears under the letters "DATA" in the Programmer display.
10. Enter the appropriate two-digit hexadecimal value to apply a logic high to the line under question, per the table below.

To pull	OPP1 (P50, IC903-17)	high, enter	01
"	OPP2 (P51, IC903-18)	"	02
"	OPP3 (P52, IC903-19)	"	04
"	OPP4 (P54, IC903-21)	"	10
"	OPP5 (P55, IC903-22)	"	20
"	OPP6 (P56, IC903-23)	"	40
"	OPP7 (P57, IC903-24)	"	80

11. When finished, disconnect the Programmer and turn it off. Disconnect the radio from its 13.6-Volt power source for at least ten seconds. If the radio is equipped with the 70-2925 Memory Back-up Kit, short the terminals of the supercapacitor while radio power is disconnected.

**• IC903 — PORT 6 (P6x), Inputs and Outputs**

**Inputs (P63 and P66):**

1. Using the Programmer, enter this address: 0017, then press ENT. "0017" appears under the letters "ADS" and a two-digit hexadecimal designator appears under the letters "DATA" in the Programmer display.
2. Enter FA, then press ENT. This establishes a reference. The next address (18) will appear.



# SERVICING

70-3400/3800

3. Press **UP ARROW**, then **DOWN ARROW**. Address 17 will return with a new DATA value.

If DATA is	voltage at P63 (IC903-28)	voltage at P66 (IC903-31)
FA	HIGH	HIGH
F2	LOW	HIGH
BA	HIGH	LOW

### Outputs (P60, P61, P62, P64, P65):

1. Press **MNL**, then enter this address: 0017 (hex). Press **ENT**. "0017" appears under the letters "ADS" and a two-digit hexadecimal designator appears under the letters "DATA" in the Programmer display.

2. If you wish to output a logic high from a Port-A line, find the appropriate byte in the HIGH column of **Table 3 - 4**, and enter its two hexadecimal digits into the Programmer. Press **ENT**. A short beep will sound. If you wish to output a logic low instead, choose the appropriate byte in the LOW column to enter. The bytes in the chart are designed to switch the selected line, only; and leave the rest unchanged.

3. When finished, disconnect the Programmer and turn it off. Disconnect the radio from its 13.6-Volt power source for at least ten seconds. If the radio is equipped with the 70-2925 Memory Back-up Kit, short the terminals of the supercapacitor while radio power is disconnected.

**Table 3 - 4**

BIT	IC901 PIN NO.	FUNCTION	BYTE TO BE ENTERED FOR	
			HIGH	LOW
0	9	LO= Audio path switched for receive	FB	FA
1	10	HI= high beep level	FA	F8
2	11	HI= mute beeps	FE	FA
4	14	LO= latch CTCSS serial data on PA0	FA	EA
5	15	not used	---	---

DC VOLTAGE CHARTS

LOGIC BOARD

Table 3 - 5 — Integrated Circuits

PIN NO.	IC904 MB3771	IC905 14053B	IC906 uPC4558G	IC907 MX365P	IC909 14066B	IC912 uPC4519	IC913 7805
1	1.7	2.5	2.5	5.0	2.5	2.6	13.6
2	1.8	2.6	2.5	2.5	2.5	2.6	0.0
3	0.0	2.6	2.5	2.5	---	2.6	5.0
4	0.0	2.5	0.0	0.0	---	5.0	
5	5.0	2.5	2.5	5.0	---	2.6	
6	5.0	0.0	2.5	0.0	---	2.6	
7	1.5	0.0	2.5	---	0.0	2.6	
8	5.0	0.0	5.0	---	2.5	2.6	
9		---		4.9	2.5	2.6	
10		---		4.9	2.5	2.6	
11		---		0.0	2.5	0.0	
12		2.5		3.2	---	2.6	
13		2.5		---	---	2.6	
14		2.5		---	5.0	2.6	
15		2.6		---			
16		5.0		2.5			
17			4.9				
18			4.9				
19			2.5				
20			2.5				
21			2.5				
22			2.1				
23			2.3				
24			2.3				

3

**40-WATT PA MODULE****Table 3 - 6 — TRANSISTORS**

<b>SYMBOL</b>	<b>TYPE</b>	<b>BASE</b>	<b>COLL</b>	<b>EMIT</b>	<b>FUNCTION</b>
Q501	2SC1971	0.85	5.2	0.0	Pre-Driver
Q502	2SC2539	-0.16	5.0	0.0	Driver
Q503	2SC2694	-0.38	8.4	0.0	Final
Q504	2SC945Q	12.7	5.5	12.0	Current Regulator
Q505	2SC2462	0.0	8.5	0.0	LO Power Clamp
Q506	2SC2462	6.1	12.7	5.4	Differential Amp.
Q507	2SC2462	7.5	8.7	6.8	Differential Amp.

**110-WATT PA MODULE****Table 3 - 7 — Transistors**

<b>SYMBOL</b>	<b>TYPE</b>	<b>BASE</b>	<b>COLL</b>	<b>EMIT</b>	<b>FUNCTION</b>
Q501	2SC2538	0.3	—	0.0	Pre-Driver
Q502	2SC2539	0.0	11.0	0.0	Driver
Q503	2SC2630	0.0	12.5	0.0	Driver
Q504	2SC2694	0.0	12.5	0.0	Final
Q505	2SC2694	0.0	12.5	0.0	Final
Q506	2SB945Q	—	—	12.5	Current Regulator
Q508	2SC2462	2.0	9.0	1.4	Differential Amp.
Q509	2SC2462	2.0	—	1.4	Differential Amp.
Q510	2SC2462	0.7	0.6	0.0	Relay Driver



RF BOARD

Table 3 - 8 — Transistors

SYMBOL	TYPE	MODE	BASE	COLL	EMIT	FUNCTION
Q101	2SC2462LC			8.9	9.0	8.1
Q112	2SC3357	TX	3.8		3.0	TX Preamp
Q113	2SC2462LC	TX	0.0	4.0	0.0	Switch
Q115	DTC124EK		0.0	8.5	0.0	Buss Driver
Q201	2SC3357	RX	1.1	10.4	0.4	RF Amplifier
Q204	2SC3357	RX	5.7	12.2	4.9	Injection Amp
Q206	2SC3357	RX	1.5	7.5	0.7	1st IF Amp
Q261	2SC2620QB	RX	0.7	3.3	0.0	1st IF Amp
Q262	2SC2462LC	RX	2.3	4.1	1.9	60 kHz Amp
Q401	2SB798	RX	9.1	0.0	9.1	Switch
		TX	8.5	9.1	9.1	
Q402	2SB798	RX	8.5	9.1	9.1	Switch
		TX	9.1	0.0	9.1	
Q403	DTA114YK	RX	9.1	8.5	9.1	Switch
		TX	0.0	9.1	9.1	
Q404	DTC124EK	RX	0.0	9.1	0.0	Switch
		TX	5.0	0.3	0.0	
Q406	2SB798	RX	12.5	13.0	13.2	Regulator
		TX	13.1	0.0	13.6	
Q407	2SC2462	RX	9.1	12.5	8.5	Switch
		TX	0.0	13.1	0.0	
Q702	2SC2351	RX	2.4	7.9	1.7	Buffer Amp
Q703	2SC2351		2.6	7.0	2.2	Buffer Amp.
Q722	2SC2351	TX	2.5	8.0	1.9	Buffer Amp.

3

Table 3 - 9 — F. E. T. 's

SYMBOL	TYPE	MODE	GATE 1	GATE 2	SOURCE	DRAIN	FUNCTION
Q202	2SK125	RX	0.0		13.1	2.4	First Mixer
Q203	2SK125	RX	0.0		13.1	2.4	First Mixer
Q701	3SK151	RX	3.8	4.7	6.9	3.3	RX VCO
Q721	3SK151	TX	3.7	4.6	7.0	3.2	TX VCO

**Table 3 - 10 — Transistor Packs**

SYMBOL	TYPE	MODE	PIN NUMBER					
			1	2	3	4	5	6
Q102	IMB4	RX HI	0.0	7.9	0.0	7.4	0.0	0.6
		RX LO	7.7	0.6	0.0	0.0	0.0	7.9
		TX HI	0.0	0.0	7.9	7.7	0.6	0.0
		TX LO	7.7	0.0	0.6	0.0	8.0	0.0
Q103	IMH1	RX HI	2.9	2.9	0.0	0.0	0.0	0.0
		RX LO	2.9	2.9	0.0	0.0	0.0	0.0
		TX HI	0.0	0.0	0.0	8.0	5.0	0.0
		TX LO	0.0	0.0	0.0	8.0	5.0	0.0
Q104	IMD3	RX HI	7.8	7.8	7.9	0.0	0.0	0.0
		RX LO	8.0	0.6	7.9	7.8	0.0	0.0
		TX HI	0.0	0.0	0.0	0.0	5.0	0.0
		TX LO	0.0	0.0	0.0	0.0	5.0	0.0
Q105	IMD3	RX HI	0.0	0.0	7.9	7.8	9.8	0.0
		RX LO	3.0	7.9	7.9	0.0	0.0	0.0
		TX HI	0.0	0.0	0.0	0.0	9.8	0.0
		TX LO	3.0	0.0	0.0	0.0	0.0	0.0
Q106	IMD3	RX HI	0.0	0.0	0.0	0.0	9.8	0.0
		RX LO	7.6	0.0	0.0	0.0	0.0	0.0
		TX HI	0.0	0.6	8.0	7.8	9.8	0.0
		TX LO	7.7	7.9	8.0	0.0	0.0	0.0
Q107	IMD3	RX HI	7.7	0.0	0.0	0.0	0.0	0.0
		RX LO	0.0	0.0	0.0	0.0	3.0	0.0
		TX HI	7.6	7.9	7.9	0.0	0.0	0.0
		TX LO	0.0	0.6	8.0	7.8	3.0	0.0
Q116	IMH1	RX/TX	9.1	0.0	0.0	8.5	0.0	0.0

**Table 3 - 11 — Analog Integrated Circuits**

PIN NO.	IC261 MB3357P		IC103 DH1072	IC104 uPC458G	IC109 DH-1071		IC111 DH-1071		IC404 HA1384
	SQ	UNSQ		TX	RX	TX	RX	TX	
1	9.0	9.0	10.0	4.9	8.7	8.7	8.7	8.7	1.6
2	8.4	8.4	0.0	4.9	0.0	0.0	0.0	0.0	3.6
3	9.1	9.1	---	4.9	0.0	0.0	0.0	0.0	0.0
4	9.1	9.1	---	9.1	0.0	0.0	0.0	0.0	0.0
5	1.0	1.0	0.0	4.9	0.0	0.0	0.0	0.0	1.4
6	1.0	1.0	5.0	4.9	0.0	0.0	0.0	0.0	1.5
7	1.0	1.0	0.0	4.9	0.0	0.0	0.0	0.0	6.9
8	9.1	9.1	0.0	4.9	8.8	0.0	0.0	8.9	13.0
9	4.1	4.1	0.0	4.8	---	---	---	---	0.0
10	1.9	1.9	0.0	4.9	---	---	---	---	13.6
11	1.9	1.9	---	0.0	---	---	---	---	13.0
12	0.8	0.2	---	4.5	---	---	---	---	6.9
13	0.0	8.4	---	5.0	---	---	---	---	---
14	1.0	0.0	---	5.0	---	---	---	---	---
15	0.0	0.0	---	---	---	---	---	---	---
16	1.9	1.9	---	---	---	---	---	---	---

**3**

**NOTES**

**SECTION 4**

**CIRCUIT DESCRIPTIONS**

# CIRCUIT DESCRIPTIONS

---

70-3400/3800

## NOTES

Faint, illegible text, likely bleed-through from the reverse side of the page.

## RF BOARD

The SYN-TECH II radio unit is comprised of three major PC boards: the Logic Board, which contains a microcomputer and its peripheral interface circuits; the RF Board, which contains a frequency synthesizer, transmit modulator, receiver, and receive audio amplifier circuits; and the PA Module, which contains the transmitter RF power amplifier.

### SYNTHESIZER

Radio frequency signals for transmission and receiver injection are produced by voltage-controlled oscillators (VCO) in a phase-lock loop (PLL) configuration.

#### • Voltage Controlled Oscillator

In this radio, two VCO's are used. Q701 operates in transmit mode to generate transmit frequencies; Q721 operates in receive mode to generate receive injection frequencies. Each is buffered independently; by Q702 and Q722, respectively. Outputs of the buffers are amplified by Q703 and stage-gain hybrids IC109 and IC111. RF signal at receiver injection frequency ( $F_c - 21.4$  MHz) is applied from the intermediate output of IC109 (pin 7) to tuned LO amplifier Q204 in the receiver circuit. Intermediate RF output of IC111 is applied to the PLL dividers. RF signal from the last output of IC111 is amplified further by the PA Module.

The resonance of each VCO is adjusted by a DC steering voltage which is produced by the remainder of the phase-lock loop, and which appears at IC103. When the frequency of the VCO output drifts away from the desired value, the loop adjusts the steering voltage to compensate. Because of this tracking characteristic, VCO steering voltage is always greater with higher VCO output frequencies (unless the band split is crossed).

Because of circuit parameters, a single VCO tank cannot tune across the entire 24 MHz channel spread. Each of the two VCO's contains two electrically-tunable tank circuits: L702/L722 and L712/L732. Only one of the four tanks is switched in at a time and they are selected by the VCO CNT output of IC113 and TXDL from the Logic Board. The microcomputer sets VCO CNT to logic low when operating channel frequency is below a band-split point and it sets TXDL to logic high during transmit

mode. Q102—Q107 produce four tank-selecting voltages from VCO CNT and TXDL: VCO-TX-8V, VCO-TX-LO, VCO-RX-8V, VCO-RX-LO. Each tank-selecting voltage applies forward bias to a PIN diode (D706/D726) that connects a respective inductance-capacitance network to oscillator Q701/Q721. Each network is independently calibrated by L702, L712, L722, or L732.

Resonance of each VCO tank is voltage-tuned by varactor diodes D701—D704, D711—D714, D721—D724, and D731—D734, respectively. Loop steering voltage applies reverse bias to all these varactor diodes simultaneously. As steering voltage increases, varactor diode capacitance decreases; thus, net capacitance in each tank decreases, which increases resonant frequency of the tanks.

#### • Loop Dividers

The amplitude of the VCO signal from IC111 pin 3 is sufficient to feed prescaling frequency divider IC101, which applies an output pulse to IC102 pin 10 once every 128 or 129 input cycles. Additional frequency division is performed within IC102 to produce 2.5 kHz. Frequency division by IC101 is switched from 129 to 128 sometime between each of its output pulses and back to 129 during the start of each of those pulses. This provides vernier division of channel frequencies that do not divide evenly. 128/129 division is controlled by a programmable pulse counter in IC102 that applies control logic voltages to IC101 control input at pin 1.

X101 is a temperature-compensated crystal oscillator that produces a reference frequency of exactly 12.8 MHz. The reference frequency is divided by IC102 to produce 2.5 kHz that is compared to the down-counted 2.5 kHz sample of VCO output. Phase and/or frequency error between each 2.5 kHz signal produces current pulses that pass through IC102 pin 17. Depending on whether the phase difference of the comparator inputs is positive or negative, current pulses flow into or out of IC102, which charges or discharges C122 through loop filter IC103. The DC voltage developed across C122 serves as VCO steering, which is first applied through an active filter within IC103 to limit loop response. Normally, the loop response is slowed enough by the active filter to block 2.5 kHz reference noise and prevent loop correction of voice modula-

## CIRCUIT DESCRIPTIONS

70-3400/3800

tion during transmit. Higher active filter rolloff frequency is selected by the microcomputer system on the Logic Board when the radio changes channels or it is keyed and unkeyed, by a logic low applied to pin 6. This increase in loop response speeds locking time.

A connection from an intermediate point in the phase/frequency comparator in IC102 is made at pin 12. When the loop is out of lock, the down-counted VCO sample is not in phase with the 2.5 kHz reference and low-going pulses appear here, which produce a logic low at pins 12 and 13 of IC107-a. This logic low is applied back to the microcomputer system as status input, plus it is inverted by IC107-c to switch on Q113. Q113 then clamps off bias to transmit RF preamplifier Q112 to prevent emission of erratic signals generated by the uncontrolled VCO.

### • Modulator

Voice signals from the hand-microphone are applied to microphone amplifier IC104-b through MIC GAIN adjustment RV103. Amplified microphone signals exit the RF Board and connect through optional circuitry that may be connected to the Logic Board. Voice signals return to IC104-c where frequency response is pre-emphasized. Signals are amplified further by IC104-d. Gain is such that stronger signals bring IC104-d output into clipping, which limits modulation. Harmonics above the 3 kHz modulation pass-band are removed by the 2.5 kHz pi-network comprised of L106/L107. Modulation signals are then adjusted by RV104/RV105 to so that modulation at limiting will produce transmitted carrier deviation of 5 kHz. FL MOD LIMIT RV104 provides maximum deviation calibration when the operating channel is below the band-split frequency; FH MOD LIMIT RV105 provides maximum deviation calibration when the operating channel is above the band-split.

RV104/RV105 tap signals produce variations in reverse bias voltages across varactor diodes in the transmit VCO tank circuit. The varying capacitance of these diodes causes variations in resonance and output frequency, thus frequency modulation results.

Low frequency CTCSS tone and DCS code signals for transmission are produced on the Logic Board and applied to both IC104-a and RV102. TONE1

RV102 applies these signals to the modulator after the pre-emphasis portion. Because the lowest frequency that can modulate the VCO is much higher than the lowest DCS signal frequency (6 Hz), the DCS/CTCSS signals are also applied to the synthesizer reference oscillator (via IC104-a) where the 12.8 MHz reference is also frequency modulated. The reference-oscillator modulation port has a low-pass characteristic with rolloff determined by the loop filter response, while the VCO modulation port has a high-pass characteristic with rolloff determined by the same element; therefore, combined modulation through both ports can be perfectly flat if both ports are amplitude-balanced. TONE2 RV101 adjusts signal amplitude into the reference oscillator port, and it must be calibrated so that a low frequency signal (under 20 Hz) produces the same RF carrier deviation as would an equal amplitude, but higher frequency (over 200 Hz) signal. While TONE2 only adjusts modulation levels of lower frequency portion of DCS signals, TONE1 adjusts modulation levels of both higher frequency portions of DCS signals and CTCSS tones.

### • Transmit RF Preamplifier

Synthesizer output at IC111 pin 7 is modulated, on-channel RF signal that is ready for amplification and emission. Q112 is a preamplifier that feeds the coaxial cable that couples the RF signal to the PA Module. DC source current to the collector of Q112 is regulated by the Automatic Power Control (APC) circuitry on the PA Module.

## RECEIVER

The entire receiver is located on the RF Board. It is electronically tuned and uses dual conversion.

### • Preselector

Through PIN-diode gates in the PA Module, RF signals are routed to the receiver input at J203. Signals at image frequencies and frequencies far removed from the desired channel are rejected by a preselector comprised of five top-coupled, parallel tanks: L201, L202, L207, L208, and L209. To tune the preselector across the entire 24 MHz channel frequency spread, the capacitance of each tank is varied by varactor diode pairs D201/D202, D203/D204, D206/D207, D208/D209, and D211/D212, respectively. All diodes are reverse biased by a DC voltage applied from a digital-to-analog converter comprised of IC113 and R147—R154.



Depending on the frequency of the operating channel, the microcomputer system will switch one or more IC113 outputs to logic low; thus accumulatively sinking currents from R150 to ground. This computer-controlled voltage source varies bias of the varactor diodes to match the preselector tank resonance to the operating channel frequency. Q201 provides adequate gain to overcome preselector signal losses and maximize receiver sensitivity.

#### • Injection

First Local Oscillator signal (channel frequency minus 21.4 MHz) is synthesized by the phase-lock loop and applied to Q204. L222 and L223 reject extraneous synthesizer signals and couple the injection signal to the first mixer. A sample of the signal is extracted by C239 and converted to a DC voltage that appears at CM118 pin 4 as an injection-level metering point.

#### • First Mixer

To maximize intermodulation immunity, a balanced configuration is utilized for the first-mixer stage. L.O. Injection is applied to L211-primary and preselector output is applied to its secondary center tap. FET devices Q202 and Q203, in complementary grounded-gate configuration, provide mixer gain and non-linearity. Q202 and Q203 drain terminals feed opposite primary windings of L219 and mixer output is taken from L219 secondary winding. Because L.O. injection is applied to the push-pull input of the mixer, some of this signal appears at mixer output; although, most is lost because L219 is designed to operate at the 21.4 MHz first IF frequency.

Signals from the preselector enter the balanced push-push input of the mixer, where they are split equally in both phase and amplitude. Those signals appear at the two primary sides of L219 in phase, where they cancel. Therefore, any signal originating from the antenna is cancelled and does not exit the mixer. Due to non-linearities in Q202 and Q203, sum and difference frequencies are produced from the L.O. injection and antenna signals. These products are not 180° out of phase; however, and they appear at mixer output.

If two undesired signals, that are 21.4 MHz apart, are strong enough to reach the mixer, their intermodulation by-products created in Q202 and Q203 will be 180° out of phase because both signals entered the balanced mixer input; thus, they will cancel in L219.

#### • First IF

Mixer output is applied to Q206, which drives L221. L221 tunes to match the input impedance of 21.4 MHz crystal filter FL261 that rejects signals outside the channel bandwidth. L261 matches FL261 to Q261 where the first IF signal is amplified at least 20 dB, then applied to second IF IC261.

#### • Second I.F.

IC261 contains all second IF circuitry, a quadrature demodulator, and threshold gate. X261 and circuitry in IC261 generate second L.O. injection of 20.945 MHz. A double-balanced mixer, which cancels both input signals internally, is used so that additional tuned circuits at its output are not needed. Mixer output signal of 455 kHz (IC261-3) is bandpass filtered further by FL262 and FL263, then super-amplified (100+ dB) by the second IF.

#### • Demodulation

The quadrature detector in IC261 is another double-balanced mixer to which limiter output is applied. Its second input is taken from 455kHz tank L262 that is also fed with limiter output (IC261 pin 7). Frequency deviations from carrier center will cause phase difference between the two demodulator inputs, which produces output. Thus, preamplified recovered audio appears at demodulator output pin 9. C273, C274, and L263 attenuate signals above 100 kHz.

#### • Audio

Recovered audio from Q263 is routed to the Logic Board for gating, descrambling and/or squelch-code detection. Audio signal returns from the Front Panel Volume control through pin 15 of J110 and is adjusted by RV401, which sets maximum audio level. Power Amplifier IC404 amplifies the audio signal and drives the speaker. IC404 contains two amplifiers whose outputs are 180° out of phase and connected to respective sides of the speaker; both speaker terminals are "live". R199 is connected in

## CIRCUIT DESCRIPTIONS

70-3400/3800

series with the internal speaker to reduce maximum audio output in under-dash installations.

- **Squelch**

Audio signals at low-pass filter L263 are routed through SQUELCH RANGE RV261 that calibrates squelch-break level when the front panel SQUELCH control is maximum. Signals at RV261-tap feed a two-tank 60 kHz filter. The resulting 60 kHz signal is amplified by IC261 and Q262, then rectified by D263

to produce a DC voltage that varies inversely with received RF-carrier level. The front panel SQUELCH control sinks current from D263 so that the voltage can be adjusted. The DC voltage is input to a level detector within IC261, and detector output is an open collector that sinks voltages to logic low when on-channel receiver input is above the squelch threshold established by RV261 and RV301. Level detector output is applied through NSQ the interconnect to microcomputer input port PC6 so that the microcomputer can take appropriate action.

## 40-WATT PA MODULE

The 40-Watt Power Amplifier (PA) Module is the rear portion of the TX/RX Unit. It contains RF circuitry that is accessible by removing its cover.

- **RF Power Amplifier**

A 50- $\Omega$  coaxial cable from the TX RF preamplifier connects to J501. A PC-board stripline is utilized to match Q501-base terminal to the coax and CV501 fine-tunes this match by balancing reactances. RF impedance at the collector Q501 is transformed by PC-board stripline to the base terminal of driver Q502, and the collector of Q502 is transformed to the base of Q503, similarly. RF impedance at the collector of final-stage Q503 is again transformed by PC stripline and fine tuned by CV504 to match circuit impedance at RF-gate D501. L511—L514 and C545—C549 comprise the harmonic filter. R512 and R513 serve to drain static and other DC potentials from the antenna.

- **Antenna Gate**

In receive mode, PIN-diodes D501 and D502 are unbiased. The RF-signal path from final-amplifier Q503 is then severed, and the impedance matching network consisting of L515, C532, and C533 routes signals from the antenna to the receiver input through 50- $\Omega$  coax at J503.

In transmit mode, D501 and D502 are biased on. The receiver port network (L515, etc.) is detuned

such that it appears as a high impedance to the antenna, and D501 couples final amplifier output to the antenna at J502.

- **Automatic Power Control**

A PC stripline ahead of the harmonic filter, plus a thin PC runner adjacent to it, serve as a directional coupler. D503 rectifies a small RF sample that is developed across the thin runner; thus producing a DC voltage that increases with RF power travelling forward into the antenna. This power-level sensing voltage is inverting input of a differential amplifier comprised of Q506 and Q507. The non-inverting input is a DC voltage produced by the H.PWR adjustment RV502. Differential amplifier output drives Q504 which is a current source that feeds primary DC to the collector circuits of both predriver Q501 and preamplifier Q112. The feedback loop, from the directional coupler to Q504, holds RF output power at the constant level determined by RV502.

If the radio is equipped with the Low Power Option, Q505 reduces the H.PWR set-point by connecting L.PWR adjustment RV501 in parallel with RV502 when a logic high is applied to J504 pin 5. Q508 is also biased on to increase the sensitivity of the differential amplifier.

## 110-WATT PA MODULE

The 110-W Power Amplifier (PA) Module is the rear portion of the TX/RX Unit. It contains RF circuitry that is accessible by removing its cover.

### • RF Power Amplifier

TX RF Preamplifier output is connected to 50- $\Omega$  J501. C501 and L501 transform the 50- $\Omega$  circuit to Q501 input impedance. A PC stripline is used to couple class-B/C biased Q501 to class-C biased pre-driver Q502. Another PC stripline matches Q502-collector circuit to driver Q503, which is also class-C biased. PC striplines split driver output to feed twin finals Q504 and Q505. Each feeder is tuned by CV503 and CV504, respectively. Final-stage outputs are combined by PC-stripline transformers, and the junction is tuned by CV505 to maximize the match to Antenna Relay K501. In transmit mode, K501 connects this RF signal to the harmonic filter consisting of L515—L518 that purifies the signal before emission by the antenna connected to J502. R521 and R522 drain static and other DC potentials from the antenna.

If the twin finals are not in balance (due to component failure or CV503/CV504 misadjustment), RF voltages at the base terminals of the finals will be unequal; and the voltage difference across R508 will be enough to overheat the resistor. The same occurs with R509 across the final-stage collectors.

### • Antenna Relay

Relay K501 is used to switch the high RF power output of Q504 and Q505 to the antenna in transmit mode. In receive mode, the normally-closed contacts of K501 connect the antenna to the receiver input through J503. K501 is energized when Q510 is biased on by the TX 8V line from the RF Board. D505 absorbs magnetically induced back-voltage while the relay is de-energized.

### • Automatic Power Control

A PC stripline ahead of the harmonic filter, plus a thin PC runner adjacent to it, serve as a directional coupler. D502 rectifies a small RF sample that is developed across the thin runner; thus producing a DC voltage that increases with RF power travelling forward into the antenna. This power-level sensing voltage is inverting input of a differential amplifier comprised of Q508 and Q509. The non-inverting input is a DC voltage produced by PWR adjustment RV501. Differential amplifier output drives Q506 which is a current source that feeds primary DC to the collector circuits of both first pre-driver Q501 and pre-amplifier Q112. The feedback loop, from the directional coupler to Q506, holds RF output power at the constant level determined by RV501.

## LOGIC BOARD

The Logic Board is located on the top side of the TX/RX unit and occupies only half of the topside area. The other half is available for mounting add-on options.

### • Microcomputer

Radio operation is under control of a microcomputer system located on the Logic Board. This system is comprised of microcomputer IC903, 8K EEPROM IC902, and peripheral port IC901.

IC903 contains the CPU, ROM, RAM, input ports, and output ports. As determined by instructions in ROM; the CPU detects logic-level voltages on input ports, then changes logic voltages on appropriate output ports to perform the correct, predetermined

action. All CPU activity is performed step-by-step in time with a clock of which frequency is fixed by crystal X901. Because of the high clock speed, microcomputer activity seems instantaneous.

EEPROM IC902 appears as additional RAM to the microcomputer, where the Data Packet of radio operating parameters is stored. IC901 contains addressable latches for expanding input and output ports, the DTMF tone generator, and the 2805 Hz tone detector. Many input and output port connections route off of the Logic Board to interface with synthesizer, receiver, transmitter, and Control Head circuitry. Further details of input and output ports are found in following text and in the Pinout Charts of both major IC's on the Logic Board.

## CIRCUIT DESCRIPTIONS

70-3400/3800

### • System Clock

A 4-MHz system clock is divided by four to produce a 1-MHz clock for the tone decoder/encoder within IC901, for the CTCSS encoder/decoder IC907, and for optional circuitry connected to P923. This clock appears at IC903 pin 64.

### • Serial-Data Peripherals

Serial data output PA0, with its corresponding clock PA1 (IC901 pins 48 and 49), is used to program CTCSS encoder/decoder IC907, frequency synthesizer IC102 on the RF Board, RF controller IC113 on the RF Board, the OP IC, and an add-on option board connected to P923. The serial data selects CTCSS tone frequency, selects synthesizer division ratios, switches control lines, and controls optional circuitry. When serial data applied from PA0 is CTCSS tone-frequency information, the microcomputer pulses output-port P64 to instruct IC907 to latch and use that data. When data is for IC102 and/or IC113, microcomputer port PB0 is pulsed to force them to latch the data. Data to IC102 and IC113 is applied in two bursts: one burst programs two of three IC102 dividers, the second burst programs a third IC102 divider and IC113.

### • Control-Head Link

A communications bus, at J906 pins 3 through 9, connects the radio microcomputer to the microcomputer in the Control Head. Push-button codes and display information are transferred through this buss as required.

### • Programming Port

The microcomputer system is programmable through the Programming Port (J909); which is a bi-directional, asynchronous, 2400/31250 bps, serial communications port. The port connects directly to the microcomputer.

### • Option Interfaces

Option plug P923 connects all necessary signals and logic functions to operate any of the four configuration types of add-on option boards (Sequential tone decoder, DTMF decoder, etc.). The

functions of OPP1—OPP7 interconnects are programmable.

Eleven PC pads exist on the Logic Board to connect the OP IC, which is a voice-scrambler module. Jumpers JP901 and JP902 must be cut when this module is installed to route audio through it. Microcomputer control of the module is accomplished by serial data applied through pins 9 and 10, and by the OPP7 interconnect.

### • DC Power and Reset

5-V DC power to all logic circuitry on the Logic Board, except IC903, is supplied from switched 13.6 volt interconnect at J906 pin 2 and is regulated by IC913. Microcomputer IC903 is powered by the 5-volt drop across D902, which is sourced by the RF Board 9-V supply through J906 pin 33. R923 and R924 supply enough current to supply the microcomputer while it is running. When the radio is turned off, the microcomputer uses little current and its 5-V source input is maintained with low current from 47,000- $\Omega$  R410 on the RF Board from unswitched primary power. Because IC903 internal RAM is still powered, last selected channel information is not lost, unless primary power to the radio is disconnected. An optional super-capacitor can be installed in the radio, to R945, to hold DC voltage to RAM after radio primary power is removed.

When the radio is turned off, DC power throughout falls slowly as the filtering capacitors discharge. When switched 13.6-V line reaches 9 V, IC904 output at pin 3 switches high, which activates IC908-a, which activates IC903 /NMI input. The microcomputer then stores status data into RAM before all power is lost. When the 5-V source of the Logic Board drops to 4.2 V, IC904 pulls the microcomputer /RESET input low which stops the system. During power up, the microcomputer holds until its /HALT input is lifted, which occurs after primary power is above 9 V and all 5-V sources have stabilized.

## AUDIO ROUTING

Most of the remaining circuitry on the Logic Board routes, detects, or produces audio signals. The following descriptions refer to the Audio Routing Schematic. Microcomputer control and input ports are denoted with labeled ovals on the schematic.

### • Transmit Audio Route

Audio signal from the hand microphone is level calibrated by MIC GAIN RV103 and pre-amplified on the RF Board. It is then routed through JP902 on the Logic Board, through audio gate IC909-c, and back to the modulator on the RF Board. IC909-c is controlled by the PA5 output port, which applies a logic low to mute voice signals during tone transmission. IC104-c on the RF Board amplifies and pre-emphasizes voice signals. IC104-d amplifies stronger signals into limiting and L106/L107 filters resultant signals and harmonics above 3 kHz. RV104 and RV105 calibrate limited signal before it frequency modulates the VCO so that the peak amplitude produces 5-kHz carrier deviation. RV104 is switched into the circuit when the active channel frequency is below or equal to the mid-band crossover frequency of 148.48 MHz for A-Band, or 162.56 MHz for B-Band. RV105 is switched in if channel frequency is above the crossover.

During transmit, CTCSS tones are produced by IC907 and level calibrated by RV902. The CTCSS signals are then amplified by IC906-a and routed to the RF Board. The signal is applied into the TONE input of the modulator where it is split: one side routes into the voice limiter for modulating the VCO; the other side is amplified by IC104a and used to frequency-modulate the phase-lock loop reference oscillator. RV101 and RV102 adjust gain of each route to balance frequency response so that the TONE modulator-input port is flat from below 10 Hz to above 2.5 kHz.

Transmitted DCS signals are also applied to the TONE interconnect. The DCS waveform, which is 134-bit-per-second serial data, is produced by the microcomputer and applied from output port P25. Output port P60 is at logic high in transmit mode, which lets the sharp-square DCS waveform pass into a low-pass filter consisting of IC912-a and IC912-b. The filter rounds the waveform by attenuating frequencies above 134 Hz. IC905-b gates the

contoured signal to the input of TONE signal pre-amplifier IC906-a.

Burst-tone signals are produced by a staircase generator comprised of IC910 and IC911. The microcomputer applies a square wave at eight times the burst-tone frequency from output port P26. For every cycle of tone, the three-bit binary value appearing at IC910-pins 3, 10, and 11 increments from zero to seven, then decrements back down to zero. Values of R939, R940, and R941 correspond to the binary weight of their respective IC910 outputs; thus, the charge on C922 varies with the binary value of those outputs, which produces a near sine wave at the desired burst-tone frequency. Burst-tone signal level is calibrated by BRST LVL RV901; then coupled to TONE signal pre-amplifier IC906-a by C974.

DTMF tone pairs are produced in the same manner by two more staircase generators within IC901 that are clocked by the microcomputer (through internal connections) when DTMF tones are sent. One generator produces row tones and the other produces column tones; with outputs at RA, RB, RC, CA, CB, and CC (pins 30, 31, 34-37). Each set of generator outputs drive respective binary-weighted resistive adders: R925—R927 and R977—R979. Both adders share C973, which smooths the stairsteps. DTMF signal is routed two ways: 1) through R929 and R930 to the ALARM interconnect which connects to the speaker amplifier input; and 2) through audio gate IC909-b and C974 to TONE signal pre-amplifier IC906-a. Audio gate IC909-b passes the signal when the microcomputer sets SW port to logic high.

If the Public Address option is installed, the operator can press a front-panel push button to activate the feature. The microcomputer will activate analog gate IC909-d by applying a logic high to port PA3. Microphone audio will then be coupled to speaker amplifier IC404 input via C910 and the ALARM interconnect. The microcomputer will also apply a logic high to the PA SW2 input of the Relay Option Board at P125 of the RF Board, which switches speaker audio away from the radio speaker and to a public address speaker connected to corresponding sockets of the Accessory Jack.

## CIRCUIT DESCRIPTIONS

70-3400/3800

### • Receive Audio Route

Audio signal from the demodulator at IC261 pin 9 is contoured by the 100 kHz low-pass filter L263. The signal is then buffered by Q263, and sent to the Logic Board via the AF interconnection. Low-pass filtered signal is also routed through SQUELCH RANGE RV261, a two-tank 60 kHz filter, and amplifiers. The resulting signal, that is the 60 kHz portion of demodulator output, is then rectified by D263 to produce a DC voltage varies inversely with received RF-carrier level. The front panel SQUELCH adjusts this DC voltage and a level detector within IC261 uses it to produce a logic low when on-channel receiver input is greater than squelch threshold. Squelch status logic is then applied to microcomputer port PC6.

For operation in 2805 Hz signaling systems, AF signal is applied to band-pass filter IC912-d. 2805 Hz dialing bursts from the filter are applied to IC901 pin 40 where they are detected by the microcomputer system.

AF signal from the RF Board is also applied to a low-pass filter comprised of IC912-a and IC912-b through analog gate IC905-a that passes the signal only during receive mode. IC912-a/IC912-b filter extracts voice signals above the DCS frequency range. DCS logic is then detected by a zero-crossing detector comprised of IC912-c and D904. IC912-c compares the difference between its input signal and a reference voltage produced by the charge on C944. C944 charge is an accumulation of the logic high bits of the DCS code and varies with the amplitude of the DCS signal; therefore, detector reference is self-adjusting. IC912-c output is applied to D904 to block small voltage changes. Recovered DCS signal is then applied to microcomputer port P20 for decoding.

CTCSS encoder/decoder IC907 contains a high-pass filter through which AF signal from the receiver is routed to strip away CTCSS and DCS signals so that they cannot be heard. AF signal is also applied to the TONE IN input of IC907 for decoding. Under

control of the microcomputer through RX MUTE port PA6, Q902 passes AF signal when received voice signals are to be heard. Under certain conditions, a logic high from the microcomputer DIRECT port PA7 toggles audio gate IC905-c, which switches out the CTCSS/DCS stripping filter.

AF signal at IC905-c is amplified by IC906-b and again gated by IC909-a which is under control of RX MUTE port PA6. The signal returns to the RF Board via the VOL A interconnect; is attenuated by the front panel VOLUME control and the MAX VOLUME adjustment; then applied to the input of speaker amplifier IC404.

Beep tones, which occur when a push button is pressed or the operator is alerted, are produced by the DTMF tone generator. When microcomputer BEEP LEVEL port P61 is logic low, it sinks audio signal through R931 to attenuate it if the sounding tone is programmed for Low Volume. When BEEP MUTE port P62 is high, Q901 sinks the signal entirely to mute it.

Speakers are driven by IC404 that contains dual audio power amplifiers in push-pull configuration. EACH SIDE OF THE SPEAKER IS DRIVEN BY A LIVE AMPLIFIER OUTPUT. Pin-7 supplies speaker signal to the SP1 and the PA1 terminals in Accessories Jack J305 that is located on the radio chassis. IC404 pin 7 also applies signal to the Control Head through J108 pin 6 to connect to the SP1 and PA1 terminals of its Accessory Jack J319 (in trunk-mount configurations). When the 70-0001 Standard Control Head is used, a jumper on J305 connects SP1 to the INT SP terminal to route the audio signal through 12- $\Omega$  attenuating resistor R199 and to the internal speaker of the Standard Control Head that is connected to J108-pins 2 and 3. IC404 pin 12 feeds the SP2 terminal of both Accessory Jacks J305 and J319, and the other side of the front-panel speaker in the Standard Control Head. PA2 terminal of J305 and J319 routes through the Relay Option Board at P124 where it is connected to IC404 pin 12 if the Public Address Option is installed and enabled.

PINOUT CHARTS

Table 4 - 1a — IC901 HN671106U (Custom Peripheral LSIC)

PIN NO.	PIN NAME	FLOW	FUNCTION LABEL	LOGIC & FUNCTION
1	PD0	BOTH	CLK	LOW = C/H data present on port
2	PD1	BOTH	D1	C/H-to-T/R Unit communications bus
3	PD2	BOTH	D2	C/H-to-T/R Unit communications bus
4	PD3	BOTH	D3	C/H-to-T/R Unit communications bus
5	PD4	BOTH	D4	C/H-to-T/R Unit communications bus
6	PD5	BOTH	D5	C/H-to-T/R Unit communications bus
7	PD6			not used
8	PD7			not used
9	PC0	INP		HIGH = 2805Hz tone detected
10	PC1	INP		not used
11	PC2	INP		not used
12	Vss			ground
13	PC3	INP	TH SW	Temp. switch status. HIGH = TX off
14	PC4	INP	C/H HGUP	HI = U/D config. or J319-3 is ground
15	PC5	INP	T/R HGUP	LOW= J505-3 is grounded
16	PC6	INP	NSQ STAT	HIGH= noise-squelch detects carrier
17	PC7	INP		not used
18	PB0	OUT	DSTB1	RF Brd. data strobe. LOW=latch data
19	PB1	OUT	LPSW1	LOW= speed PLL loop response
20	PB2	OUT	TXDL1	HIGH = Activate transmit
21	PB3	OUT	INTRX	not used
22	PB4	OUT	HORN SW	HIGH = Horn switch is on
23	PB5	OUT	DSTB2	Optnl synth. serial data strobe
24	PB6	OUT	LPSW2	LOW= switch optnl synth loop filter
25	PB7	OUT	TXDL2	Optnl synth. TX control HIGH = TX
26	TCLK	INP		Mfr. test point not used
27	TEST	INP		Mfr. test point not used
28	CHOK	BOTH		Mfr. test point not used
29	CHER	BOTH		Mfr. test point not used
30	CA	OUT		Square wave at DTMF tone-1 freq.
31	CB			DTMF tone-1 frequency 2
32	Vss			ground
33	Vdd			+5 Volts
34	CC	OUT		DTMF tone-1 frequency 4
35	RA	OUT		Square wave at DTMF tone-2 freq.
36	RB	OUT		DTMF tone-2 frequency 2
37	RC	OUT		DTMF tone-2 frequency 4
38	SE	INP		Port-D direction control
39	TPL	OUT		not used

4

# CIRCUIT DESCRIPTIONS

70-3400/3800

Table 4 - 1b — IC901 HN671106U (Custom Peripheral LSIC Continued)

PIN NO.	PIN NAME	FLOW	FUNCTION LABEL	LOGIC & FUNCTION
40	BITIN	INP		2805 Hz input for detection
41	SW	OUT		HIGH = DTMF transmit
42	PA7	OUT		RX audio path control. HIGH=direct
43	PA6	OUT		LOW = mute receive audio
44	PA5	OUT	TX MUTE	LOW = mute transmit voice audio
45	PA4	OUT	PA SW	HIGH = Public Address optn enabled
46	PA3	OUT	PA	CNTL HIGH = Audio rerouted for Pub. Add.
47	PA2	OUT	DCL	C/H data bus directn. HIGH=to C/H
48	PA1	OUT	DCLK	Clock for serial data at PA0
49	PA0	OUT	CHDT	Serial control data to RF Board
50	A0	INP		Address bus
51	A1	INP		Address bus
52	Vss			ground
53	A2	INP		Address bus
54	A12	INP		Address bus
55	A13	INP		Address bus
56	A14	INP		Address bus
57	A15	INP		Address bus
58	/DEC7	OUT		not used
59	/DEC6	OUT		not used
60	/DEC4	OUT		not used
61	/DEC3	OUT		not used
62	/DEC2	OUT		not used
63	/DEC1	OUT		not used
64	SYNC0	OUT		2805Hz detector out. HIGH= present
65	SYNC1	OUT		not used
66	OSC	INP		Tone generator and detector clock
67	E	INP		Data-bus latch clock
68	/R	INP		LOW = system reset
69	/RD	INP		LOW = Read data from microcomputer
70	/WR	INP		LOW = Write data to microcomputer
71	D0	BOTH		Data bus
72	Vss			ground
73	Vdd			+5 Volts
74	D1	BOTH		Data bus
75	D2	BOTH		Data bus
76	D3	BOTH		Data bus
77	D4	BOTH		Data bus
78	D5	BOTH		Data bus
79	D6	BOTH		Data bus
80	D7	BOTH		Data bus



Table 4 - 2a — IC903 HD6301YOP (Radio Microcomputer)

PIN NO.	PIN NAME	FLOW	FUNCTION LABEL	LOGIC & FUNCTION
1	Vss			Ground
2	XTAL	NP		Crystal oscillator, 4 MHz
3	XTAL	INP		Crystal oscillator, 4 MHz
4	MP0	INP		not used
5	MP1	INP		not used
6	/RES	INP		LOW = Microcomputer reset
7	/STBY	INP		LOW = Microcomputer standby mode
8	/NM	INP		LOW GOING = Interrupt: store status
9	P20	INP		DCS signal in (for decoding)
10	P21	OUT	CTS	p/o Std. serial port to Programmer
11	P22	INP	RTS	p/o Std. serial port to Programmer
12	P23	INP	SD	p/o Std. serial port to Programmer
13	P24	OUT	RD	p/o Std. serial port to Programmer
14	P25	OUT		DCS signal output (for transmission)
15	P26	OUT		Burst-Tone clock (tone freq. x 8)
16	P27	OUT	CD	p/o Std. serial port to Programmer
17	P50	BOTH	OPP1	Programmable option port
18	P51	BOTH	OPP2	Programmable option port
19	P52	BOTH	OPP3	Programmable option port
20	/HALT	INP		LOW = Microcomputer HALT
21	P54	BOTH	OPP4	Programmable option port
22	P55	BOTH	OPP5	Programmable option port
23	P56	BOTH	OPP6	Programmable option port
24	P57	BOTH	OPP7	Programmable option port
25	P60	OUT		Signal-path switch. LOW=RX
26	P61	OUT		HIGH = High beep level
27	P62	OUT		HIGH = Mute beeps
28	P63	INP		LOW = CTCSS Tone detected
29	P64	OUT		LO= latch CTCSS data sent on PA0
30	P65			not used
31	P66	INP	PLCL1	LOW = RF Synthesizer is unlocked
32	P67	INP	PLCL2	LOW = Optional synthesizer unlocked
33	Vcc	INP		5 Volts DC
34	A15	OUT		Address Bus, MSB
35	A14	OUT		Address Bus
36	A13	OUT		Address Bus
37	A12	OUT		Address Bus
38	A11	OUT		Address Bus
39	A10	OUT		Address Bus
40	A9	OUT		Address Bus
41	A8	OUT		Address Bus

# CIRCUIT DESCRIPTIONS

70-3400/3800

Table 4 - 2b — IC903 HD6301YOP (Radio Microcomputer Continued)

PIN NO.	PIN NAME	FLOW	FUNCTION LABEL	LOGIC & FUNCTION
42	GND			
43	A7	OUT		Address Bus
44	A6	OUT		Address Bus
45	A5	OUT		Address Bus
46	A4	OUT		Address Bus
47	A3	OUT		Address Bus
48	A2	OUT		Address Bus
49	A1	OUT		Address Bus
50	A0	OUT		Address Bus, LSB
51	D7	BOTH		Data Bus, MSB
52	D6	BOTH		Data Bus
53	D5	BOTH		Data Bus
54	D4	BOTH		Data Bus
55	D3	BOTH		Data Bus
56	D2	BOTH		Data Bus
57	D1	BOTH		Data Bus
58	D0	BOTH		Data Bus, LSB
59	BA	OUT		not used
60	/LIR	OUT		not used
61	R/W	OUT		not used
62	/WR	OUT		LOW = Writing data
63	/RD	OUT		LOW = Reading data
64	E	OUT		1 MHz clock

**OPTION CONNECTOR P923**

P923 is a receptacle for connecting various add-on options. The RF Board serial port and seven I/O lines from the microcomputer are routed here to interface to options. There are four sets of functions of these I/O lines, and each set can be selected by programming. Page 20 of 70-1080A Programmer Operator's Manual describes Programming the Option Port Type parameter; and, which configuration Type used depends on which option is connected. One of four Types are available and a function-description chart for each is provided below. If "NONE" is programmed, OPP1 through OPP7 do not function.

**OPTION PORT TYPE 1**

PIN	NAME	FLOW	FUNCTION
4	OPP1	INPUT	LOW = valid code decoded
5	OPP2	INPUT	LOW = transmit request (PTT)
6	OPP3	OUTPUT	HIGH = Auxiliary push button is on
7	OPP4	OUTPUT	HIGH = carrier received (noise squelch)
8	OPP5	OUTPUT	LOW = transmit mode
9	OPP6	OUTPUT	HIGH = CTCSS/DCS decoded
10	OPP7	OUTPUT	HIGH = latch Option Data sent on P923-12
11	CLK	OUTPUT	HIGH = data bit is on P923-12 (data clock)
12	SER	OUTPUT	serial port data line for Option Data

**OPTION PORT TYPE 2**

PIN	NAME	FLOW	FUNCTION
4	OPP1	OUTPUT	LOW = DTMF code compares true PLUS carrier is present (noise squelch) PLUS transpond Burst-Tone is complete.
5	OPP2	INPUT	LOW = transmit request (PTT)
6	OPP3	INPUT	received-DTMF-data serial port
7	OPP4	INPUT	LOW = valid data string is on OPP3
8	OPP5	OUTPUT	LOW = transmit mode
9	OPP6	OUTPUT	HIGH = bit request for OPP3 data
10	OPP7	OUTPUT	HIGH = latch Option Data sent on P923-12
11	CLK	OUTPUT	HIGH = data bit is on P923-12
12	SER	OUTPUT	serial port data line for Option Data

4

# CIRCUIT DESCRIPTIONS

70-3400/3800

## OPTION PORT TYPE 3

PIN	NAME	FLOW	FUNCTION
4	OPP1	INPUT	LOW = valid code decoded
5	OPP2	INPUT	LOW = transmit request (PTT)
6	OPP3	INPUT	channel-number serial data
7	OPP4	INPUT	HIGH PULSE = request to send data on OPP3
8	OPP5	OUTPUT	LOW = transmit mode
9	OPP6	OUTPUT	HIGH = bit request for OPP3 data
10	OPP7	OUTPUT	HIGH = latch Option Data sent on P923-12
11	CLK	OUTPUT	HIGH = data bit is on P923-12
12	SER	OUTPUT	serial port data line for Option Data

## OPTION PORT TYPE 4

PIN	NAME	FLOW	FUNCTION
4	OPP1	INPUT	LOW = data ready on OPP2-OPP5
5	OPP2	INPUT	received DTMF parallel data, bit 0
6	OPP3	INPUT	received DTMF parallel data, bit 1
7	OPP4	INPUT	received DTMF parallel data, bit 2
8	OPP5	INPUT	received DTMF parallel data, bit 3
9	OPP6	OUTPUT	LOW = DTMF code compares true PLUS carrier is present (noise squelch) PLUS transpond Burst-Tone is complete.
10	OPP7	OUTPUT	HIGH = latch Option Data sent on P923-12
11	CLK	OUTPUT	HIGH = data bit is on P923-12
12	SER	OUTPUT	serial port data line for Option Data

**SECTION 5**

**DIAGRAMS**

# DIAGRAMS

---

70-3400/3800

## NOTES

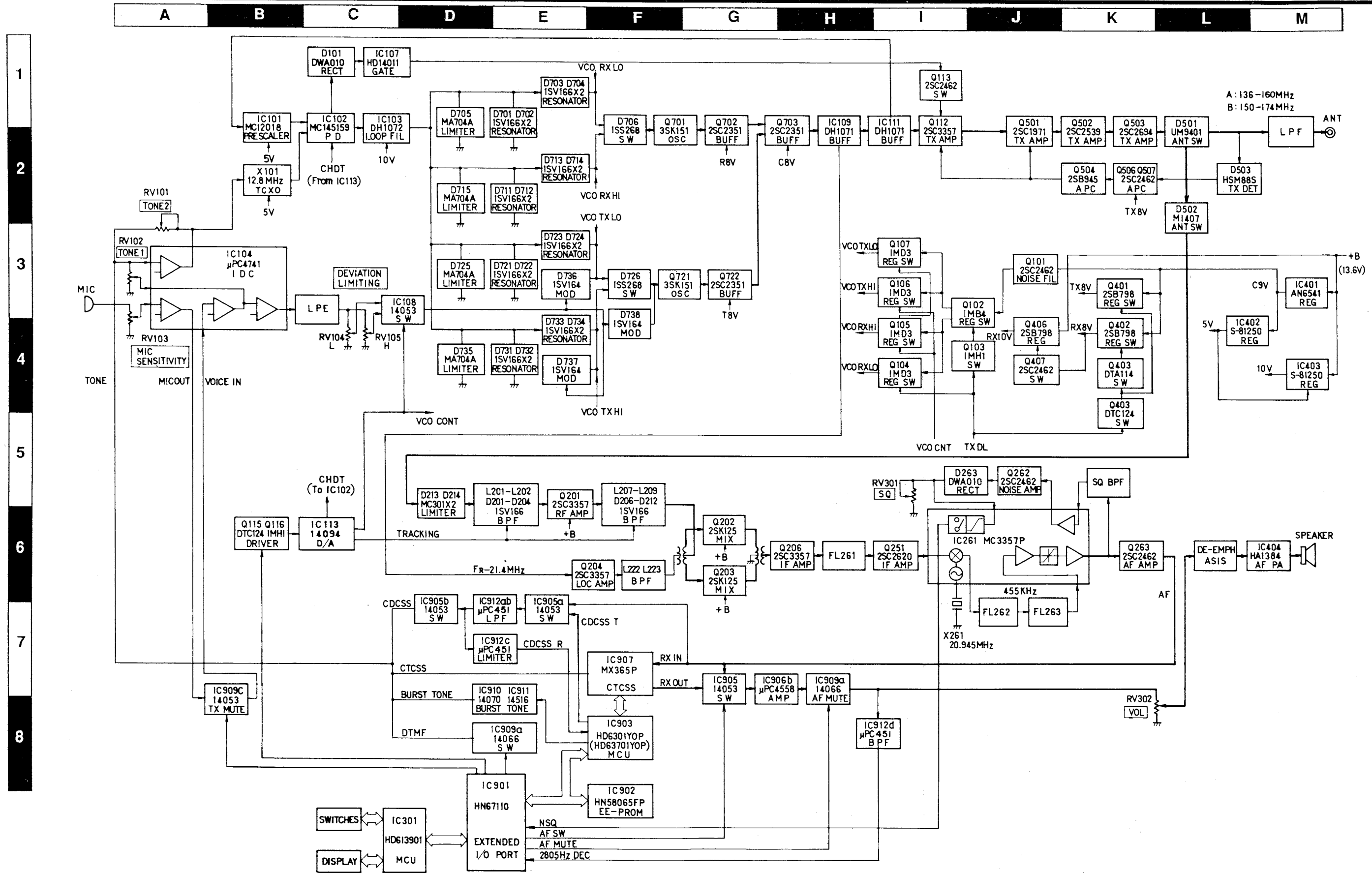

# 70-3800 BLOCK DIAGRAM

70-3400/3800

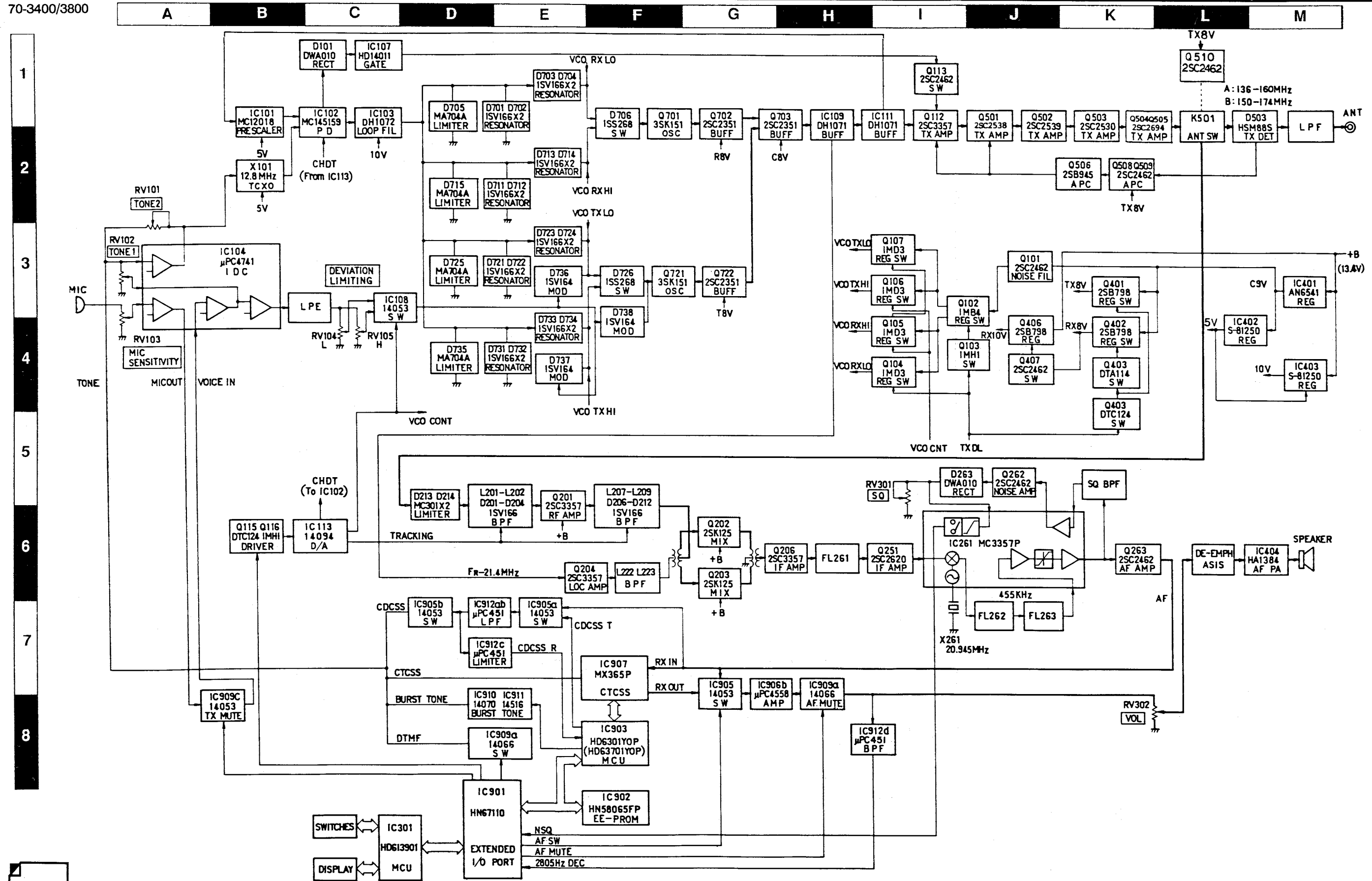



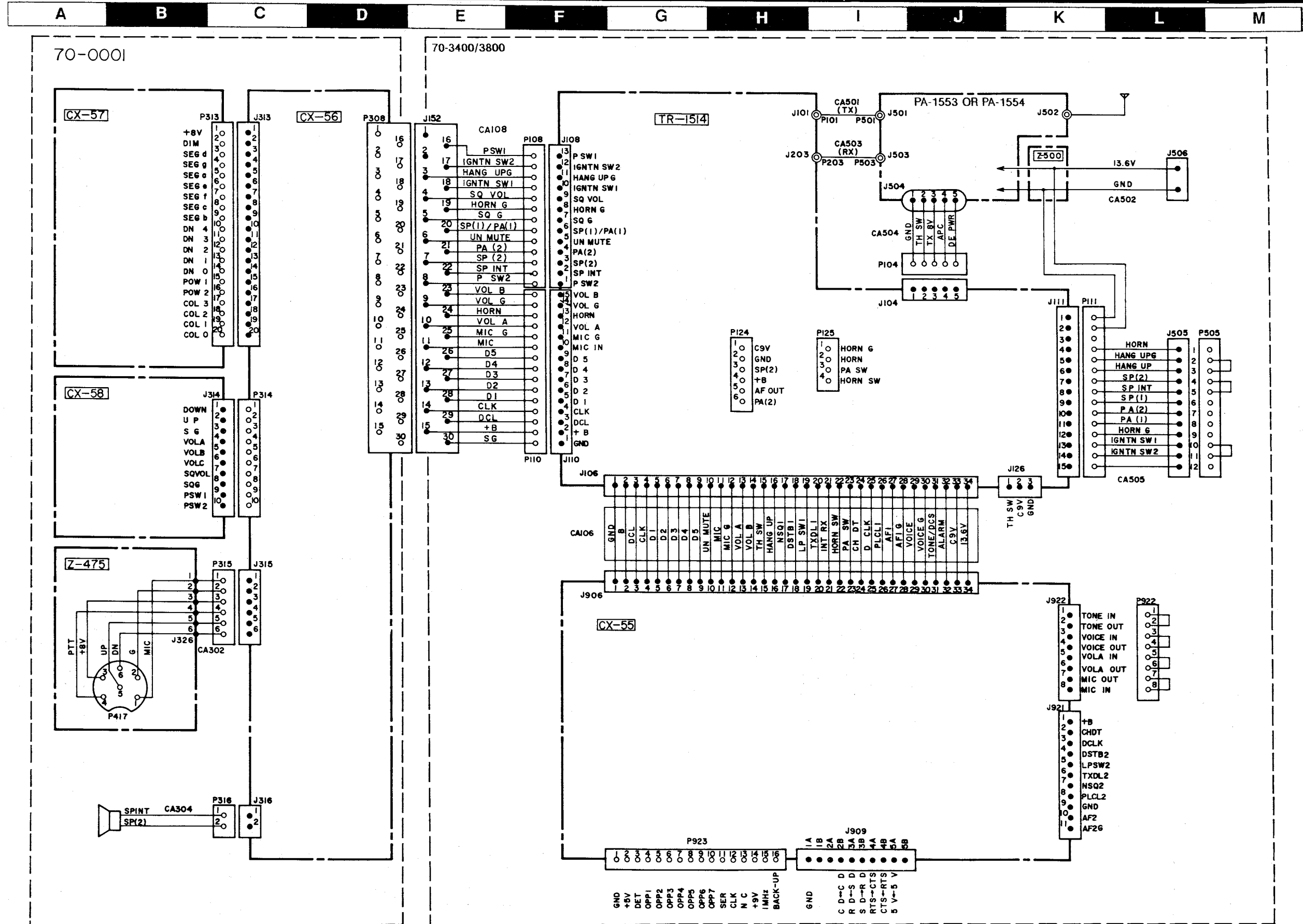

1  
2  
3  
4  
5  
6  
7  
8

# 70-4421/4851 WIRING DIAGRAM

70-3400/3800

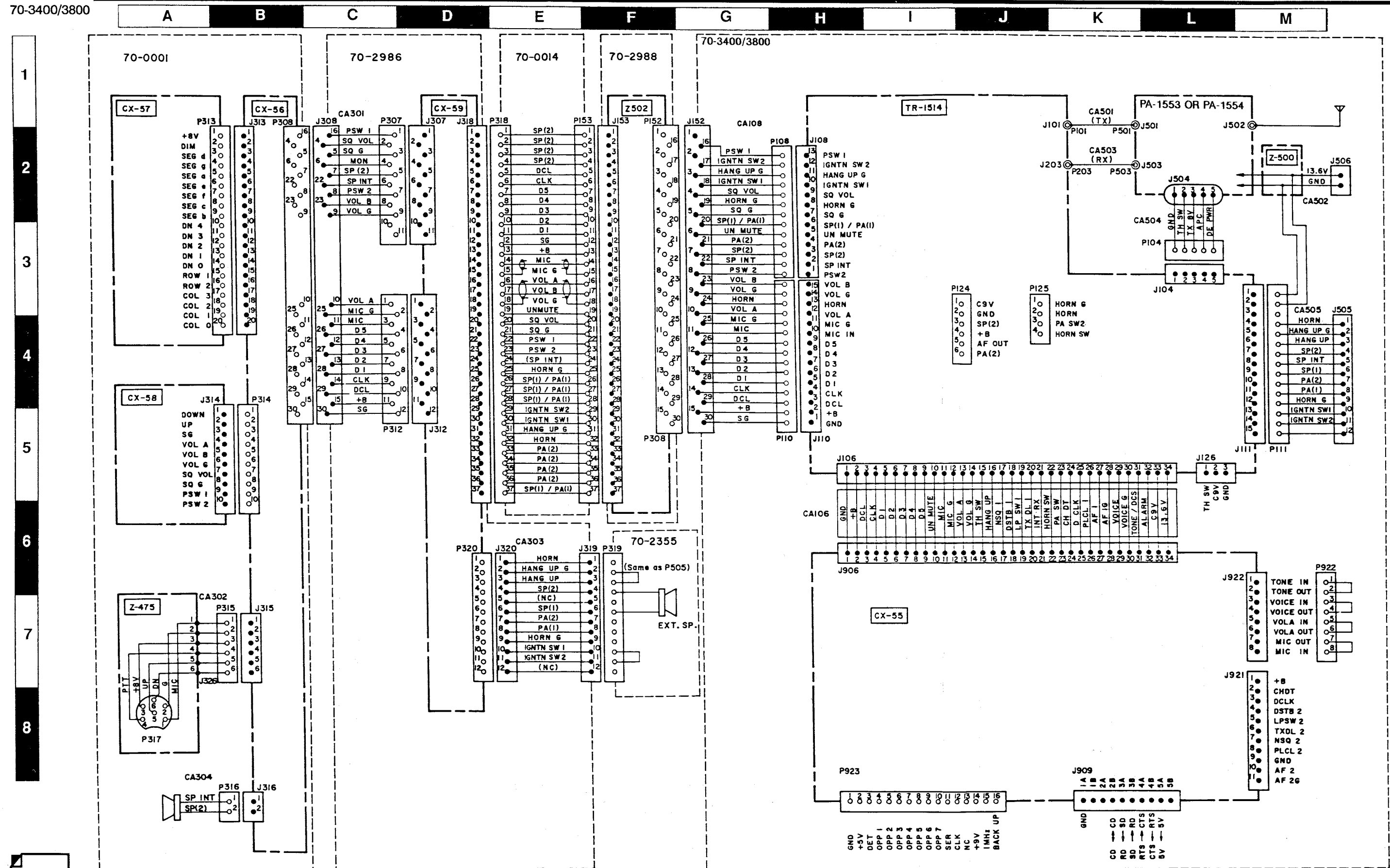

1  
2  
3  
4  
5  
6  
7  
8

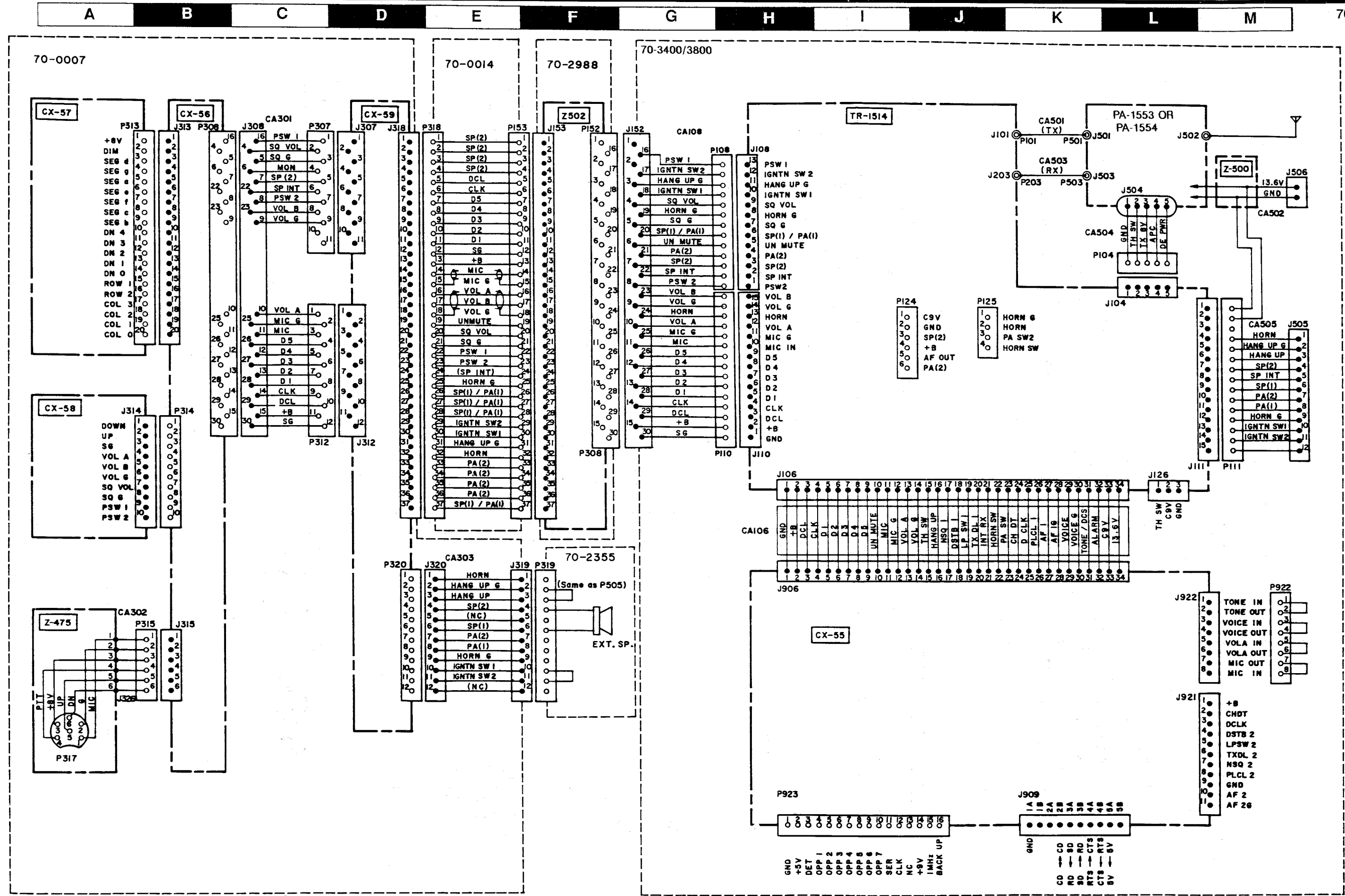

# 70-3422/3852 WIRING DIAGRAM

70-3400/3800

A B C D E F G H I J K L M

1  
2  
3  
4  
5  
6  
7  
8

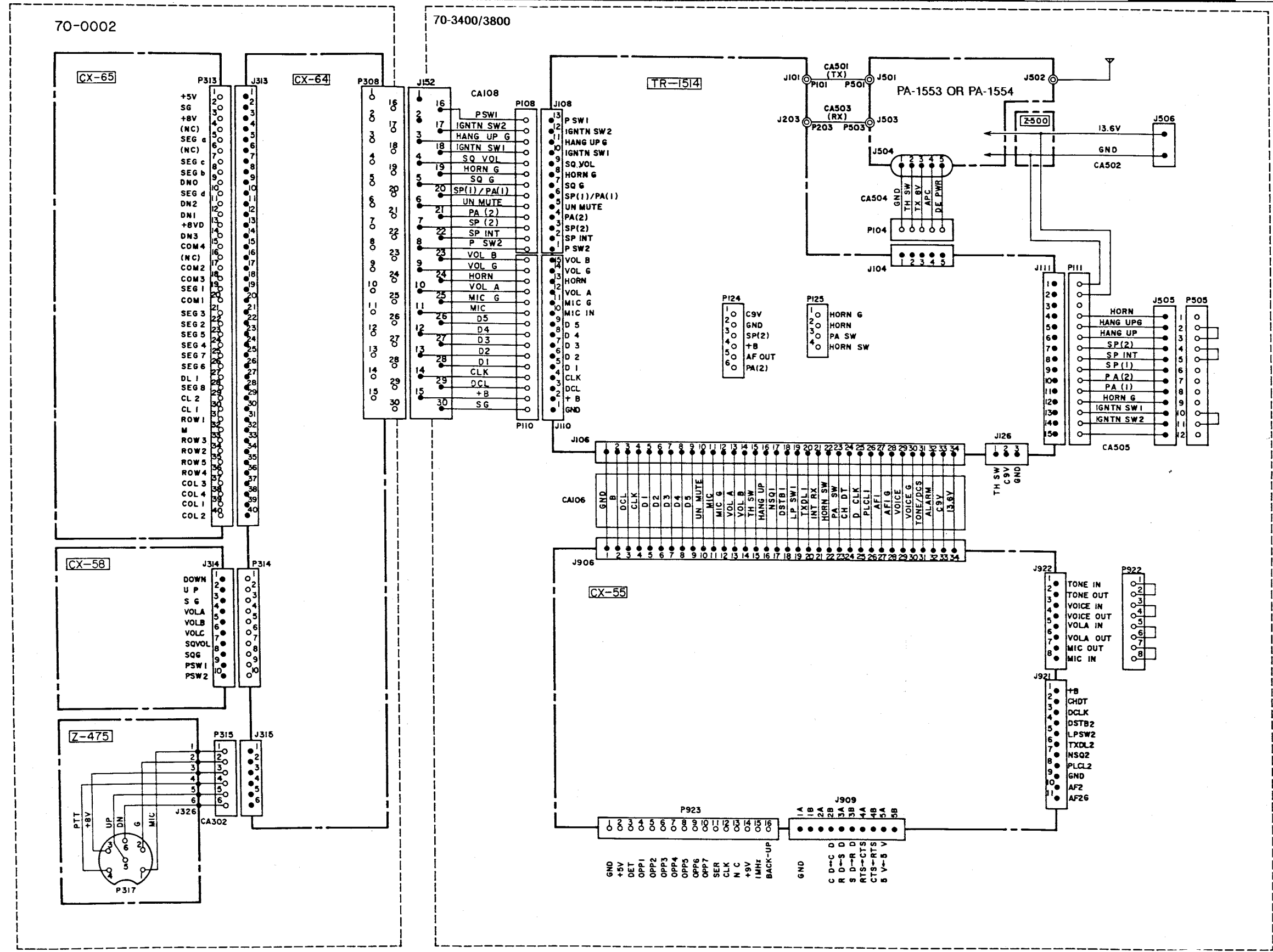

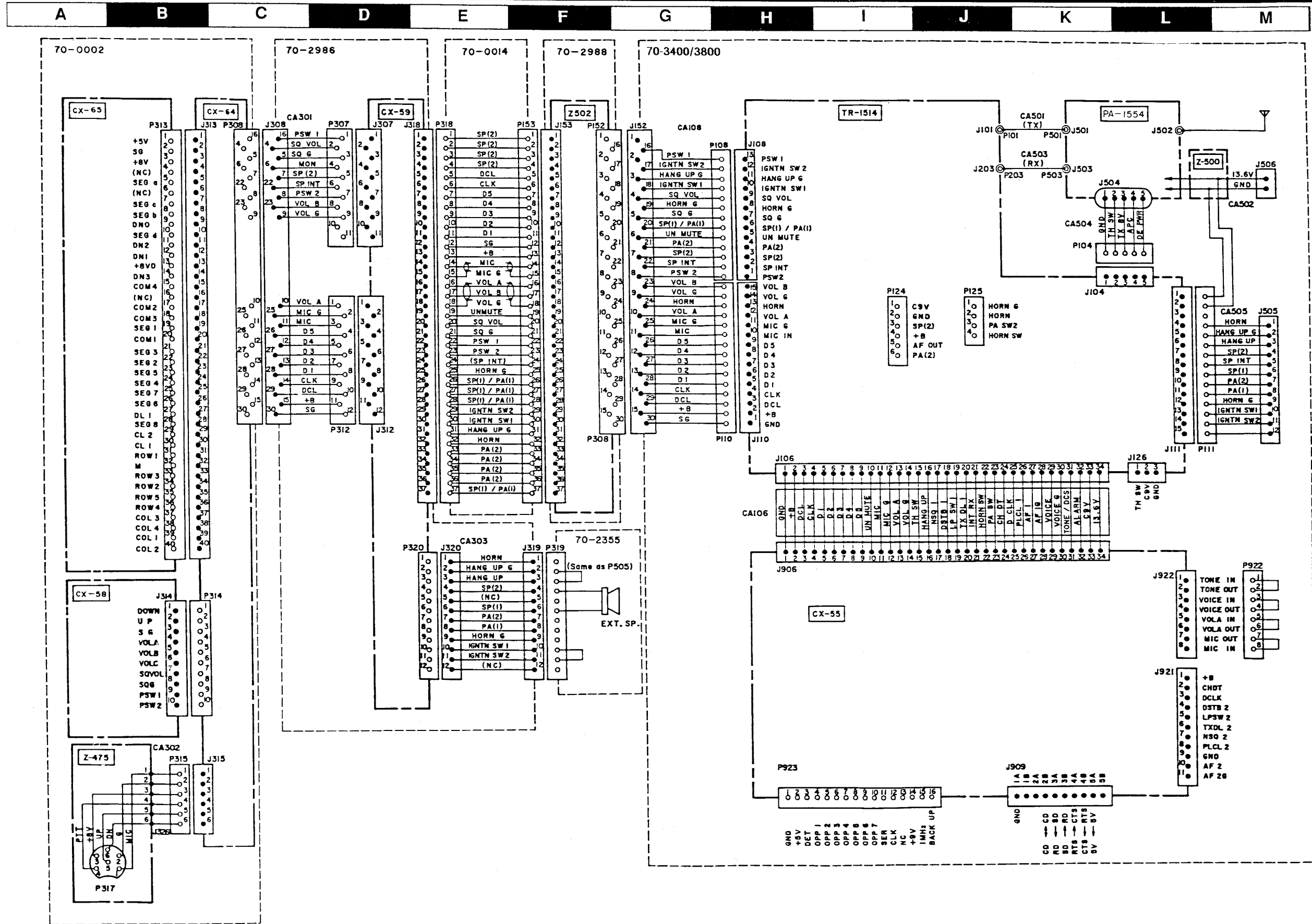

# CX-55 LOGIC BOARD LAYOUTS

70-3400/3800

A

B

C

D

E

F

G

H

I

J

K

L

M

1

2

3

4

5

6

7

8

## TOP VIEW

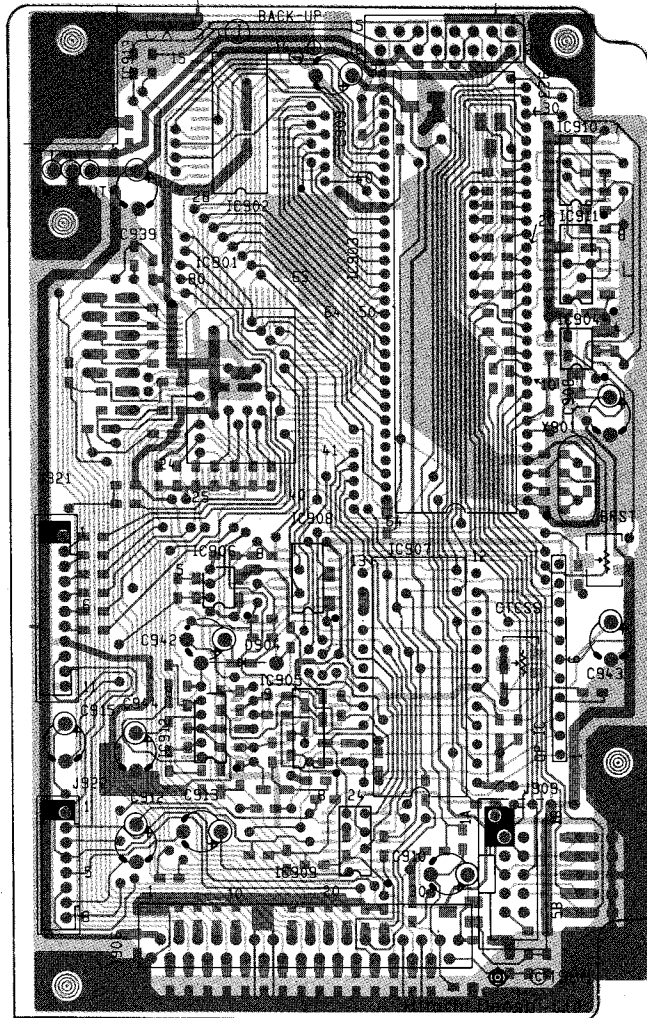
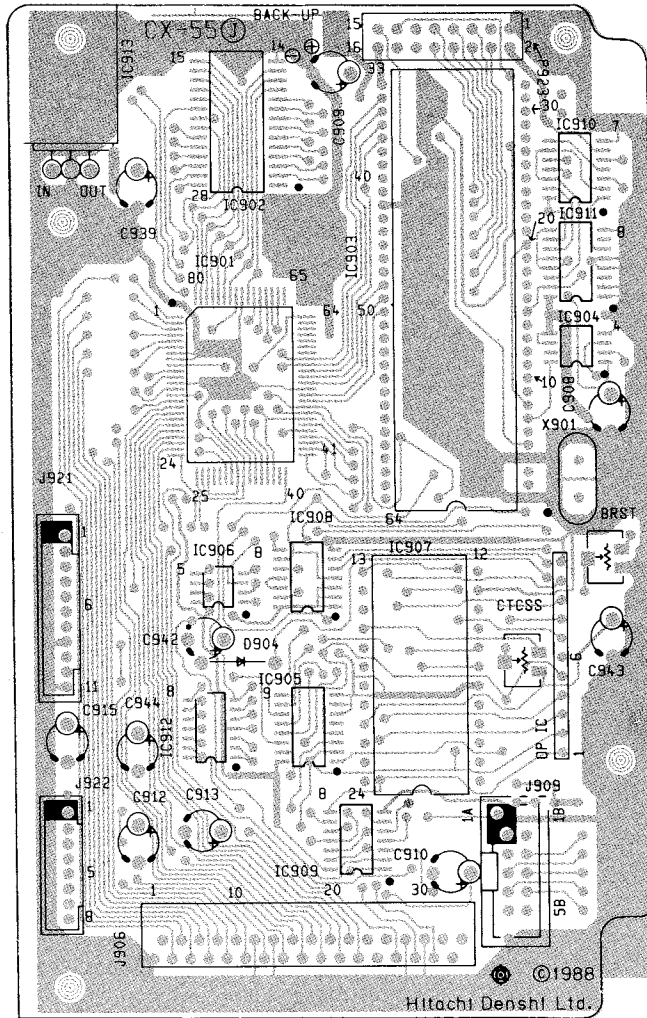

## BOTTOM VIEW

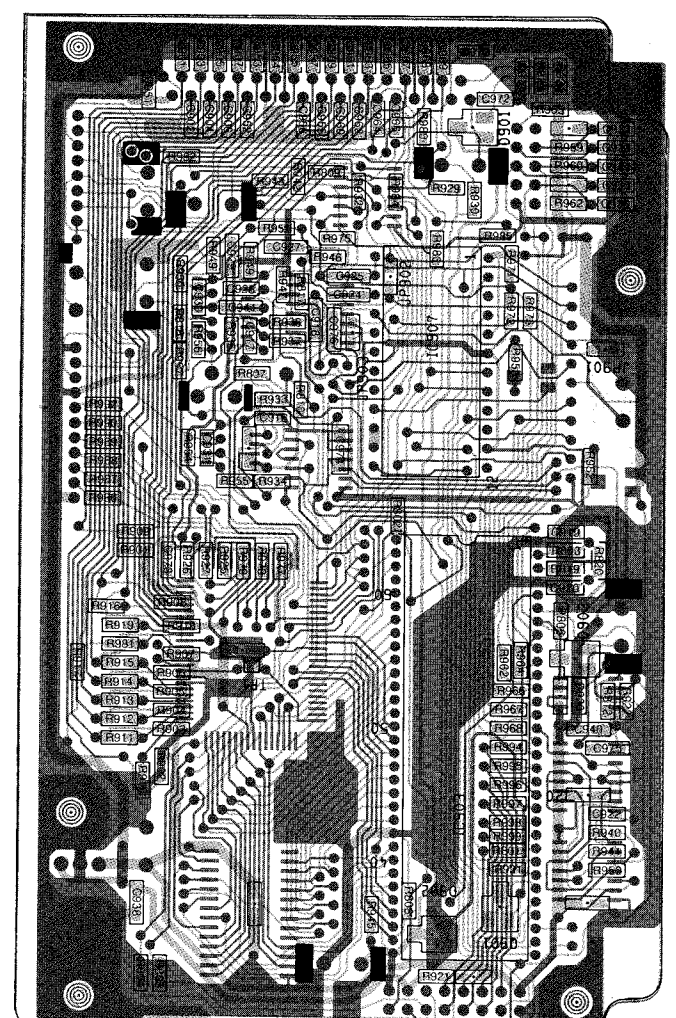
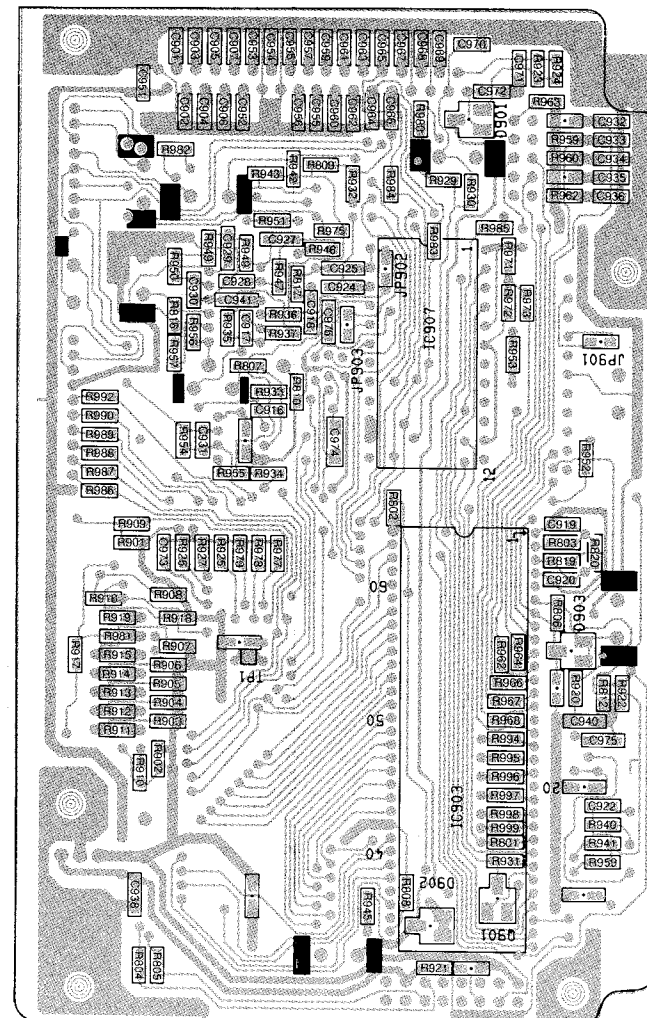

BLUE VISIBLE PLATING

RED UNDERSIDE PLATING

A B C D E F G H I J K L M

1  
2  
3  
4  
5  
6  
7  
8

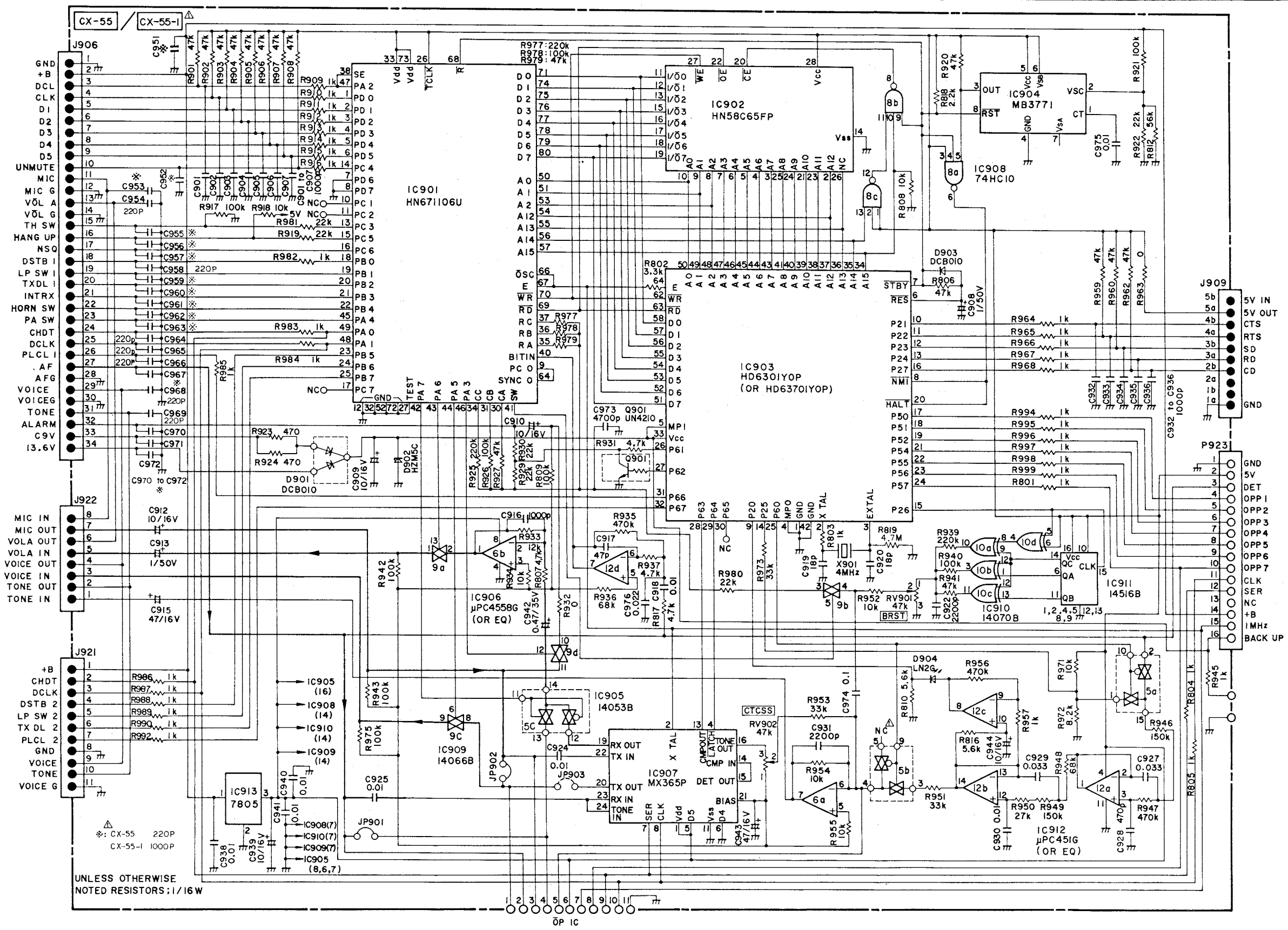

UNLESS OTHERWISE NOTED RESISTORS: 1/16W

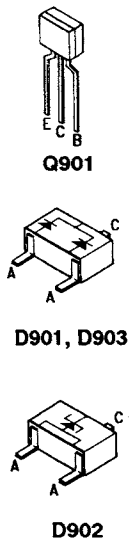

# AUDIO ROUTING DIAGRAM

70-3400/3800

A B C D E F G H I J K L M

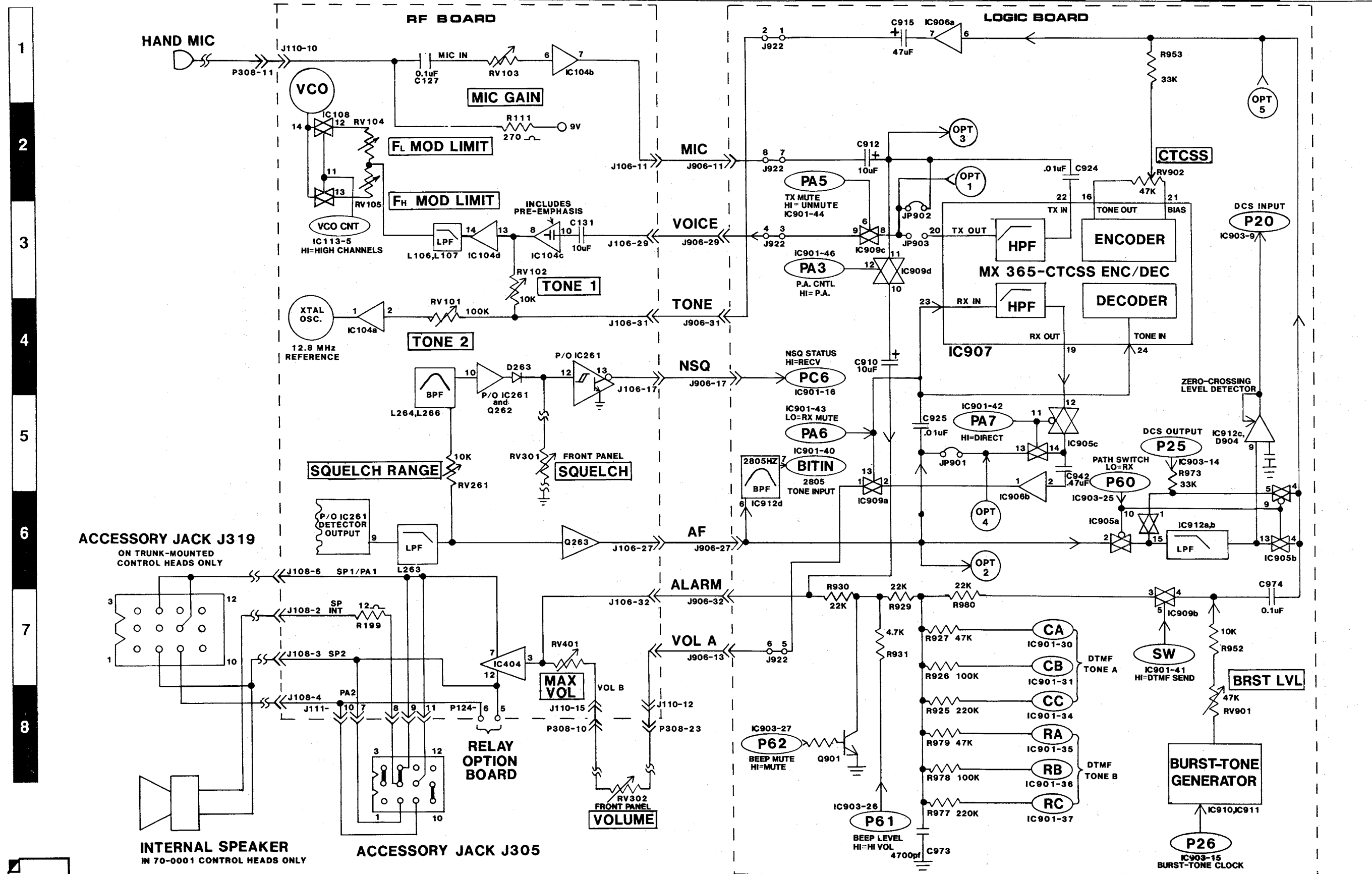



A B C D E F G H I J K L M

1  
2  
3  
4  
5  
6  
7  
8

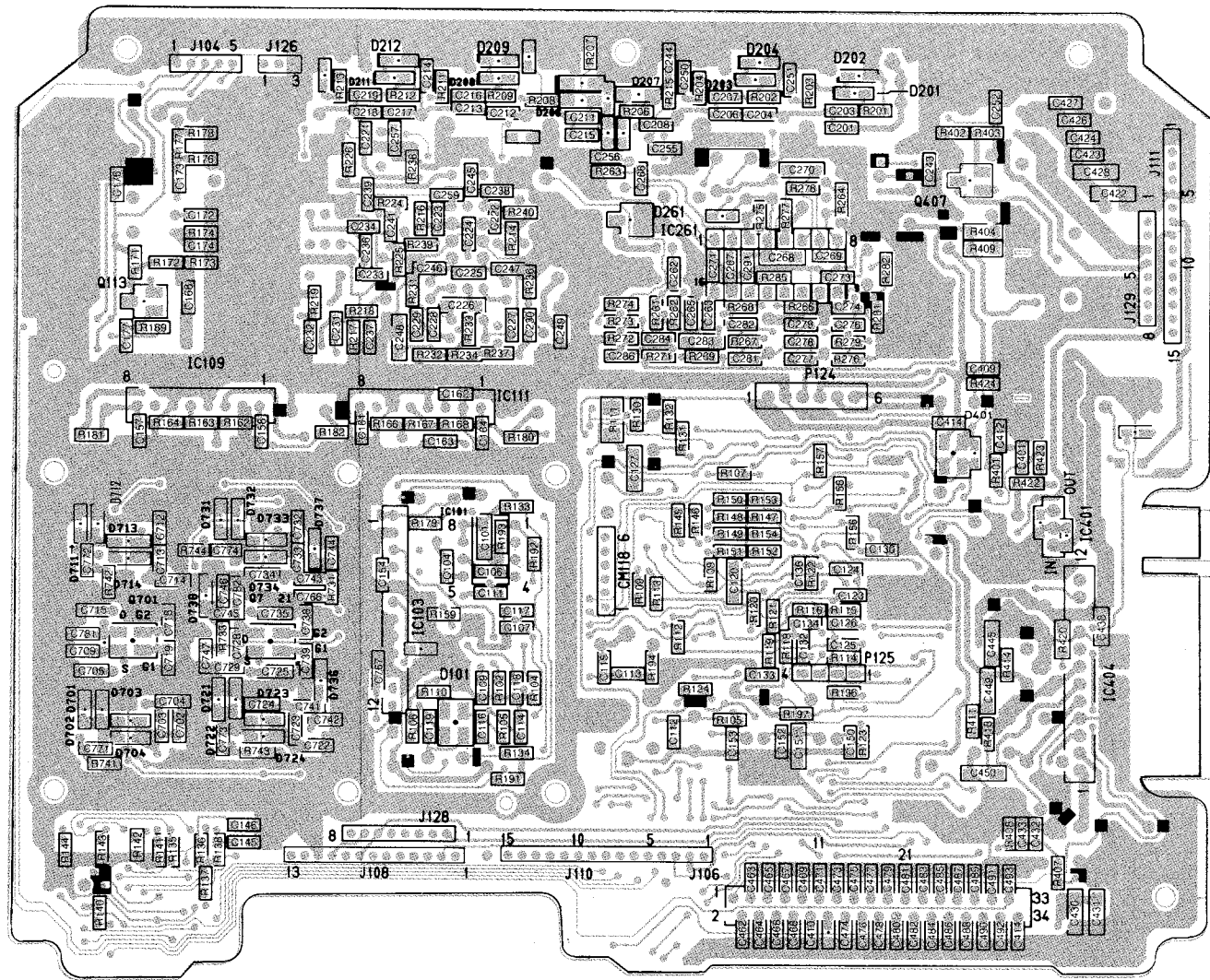
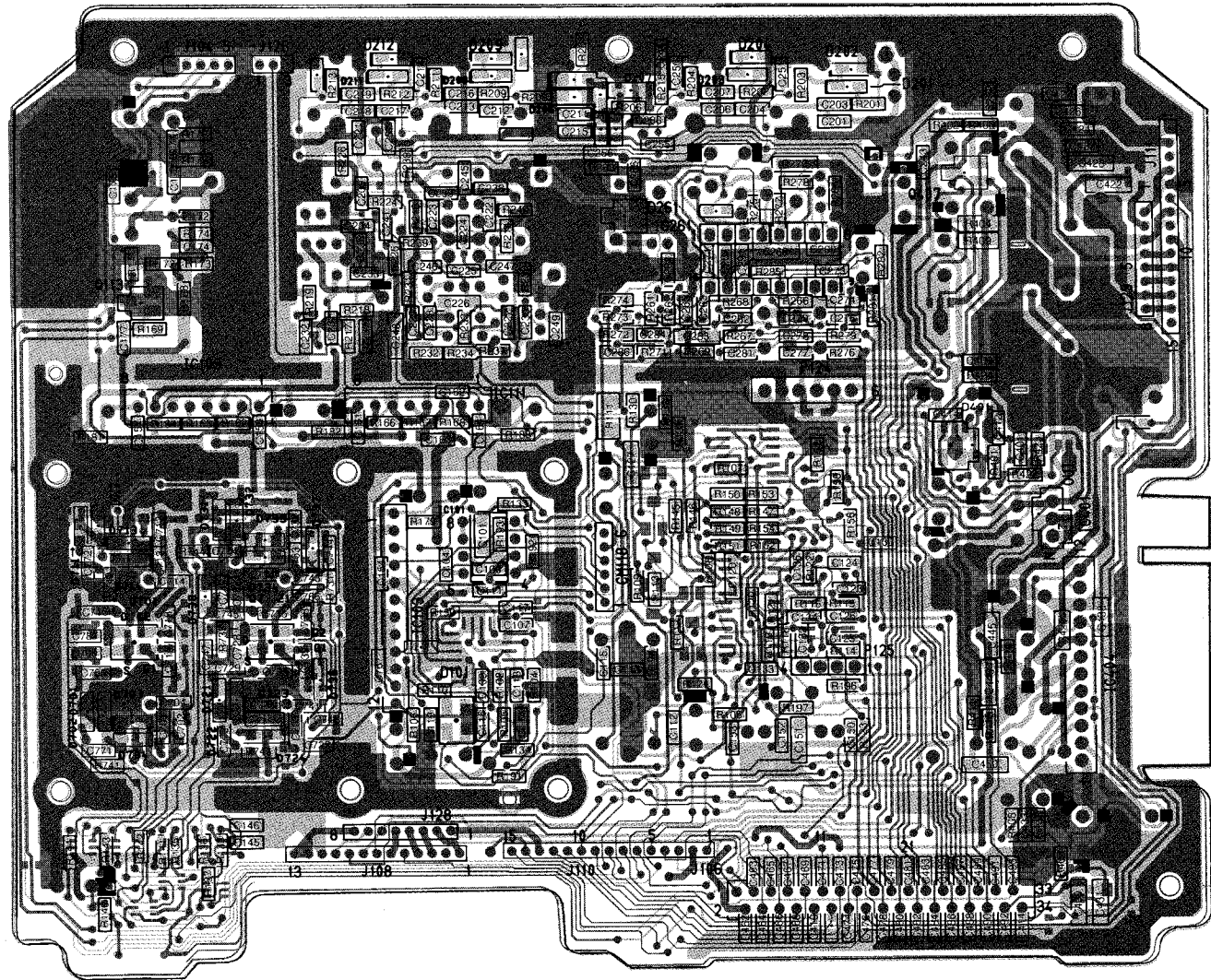

BLUE VISIBLE PLATING  
RED UNDERSIDE PLATING



TR-1514 RF BOARD LAYOUT — TOP VIEW

70-3400/3800

A B C D E F G H I J K L M

1  
2  
3  
4  
5  
6  
7  
8

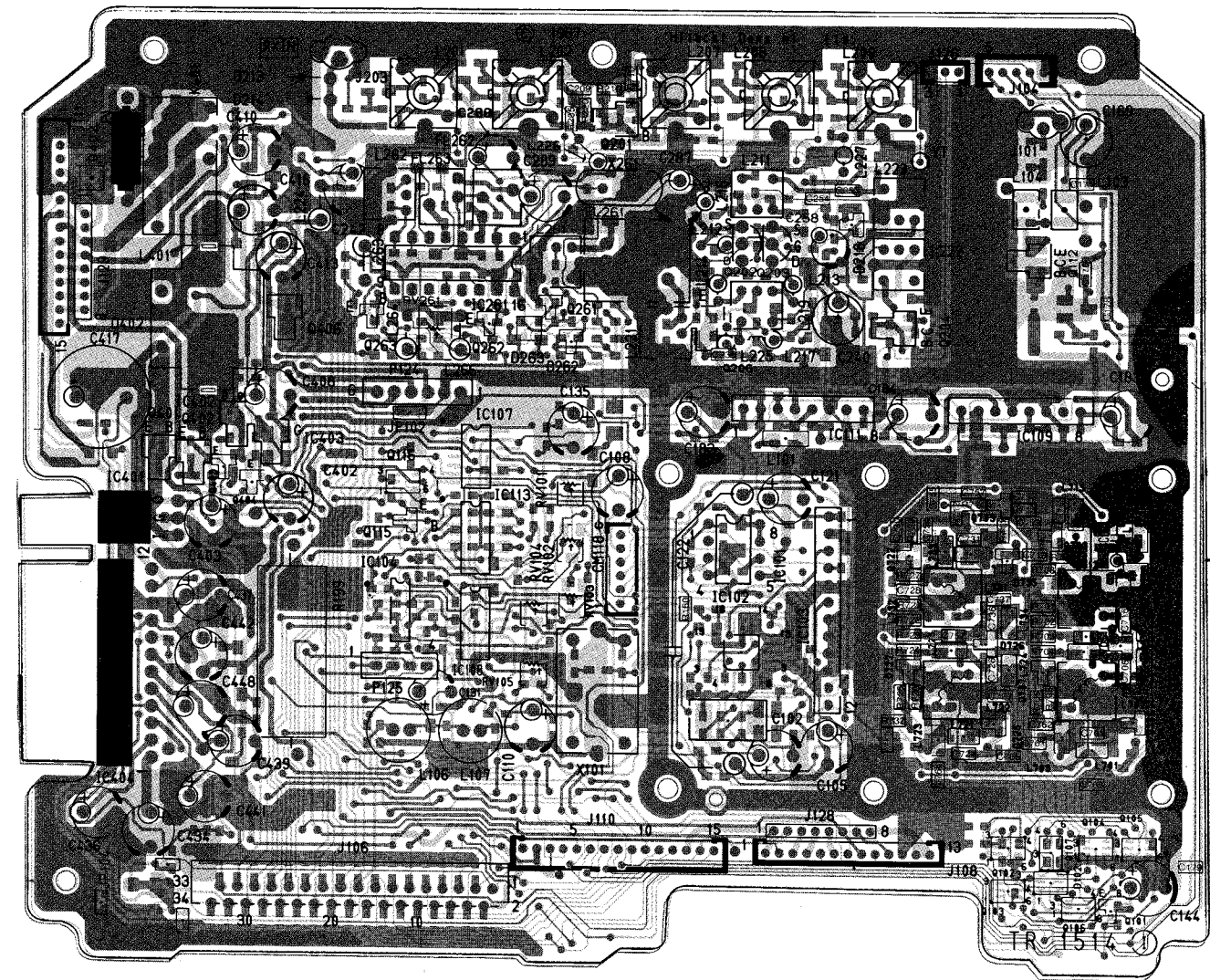
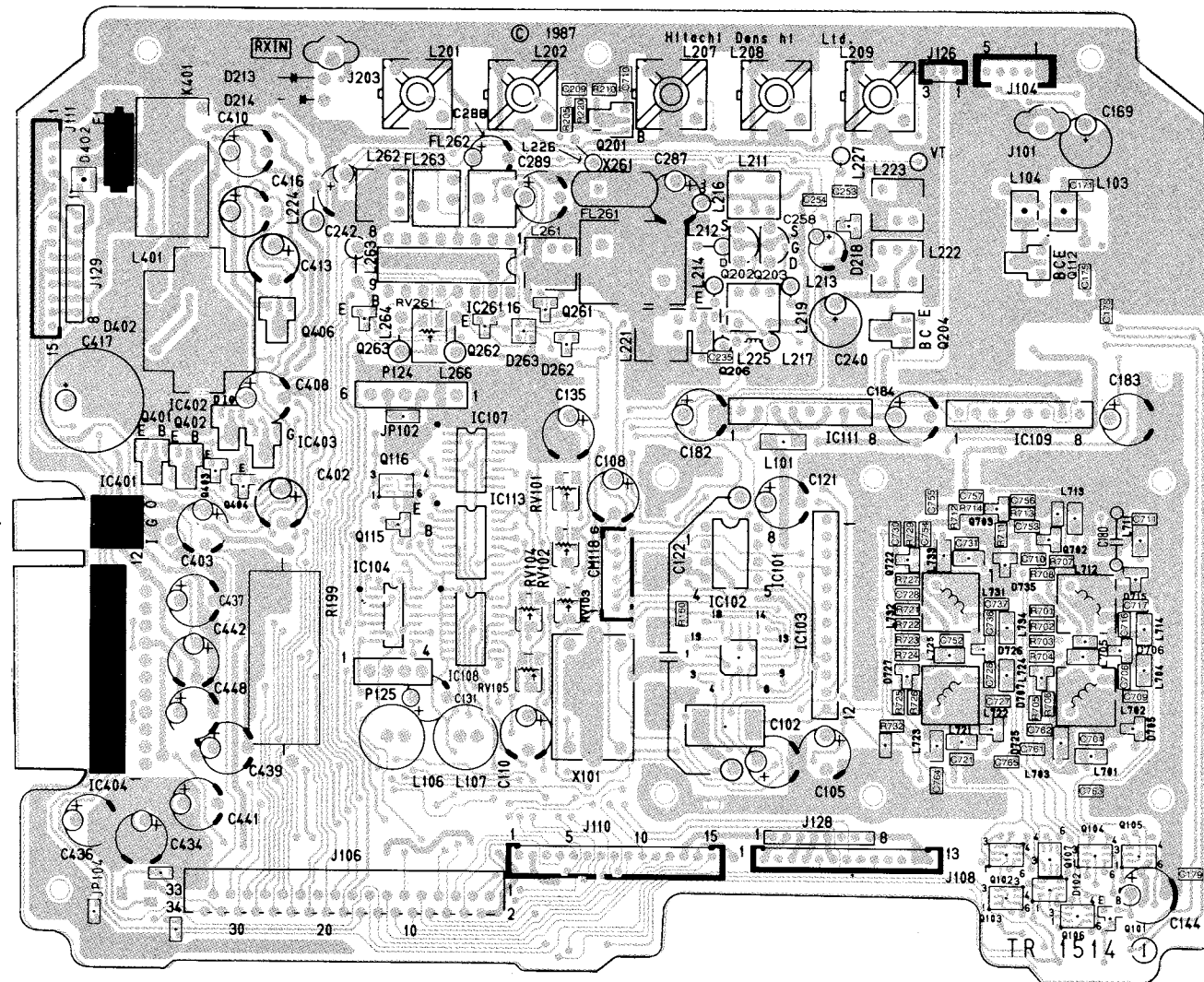

BLUE VISIBLE PLATING  
RED UNDERSIDE PLATING

A B C D E F G H I J K L M

1  
2  
3  
4  
5  
6  
7  
8

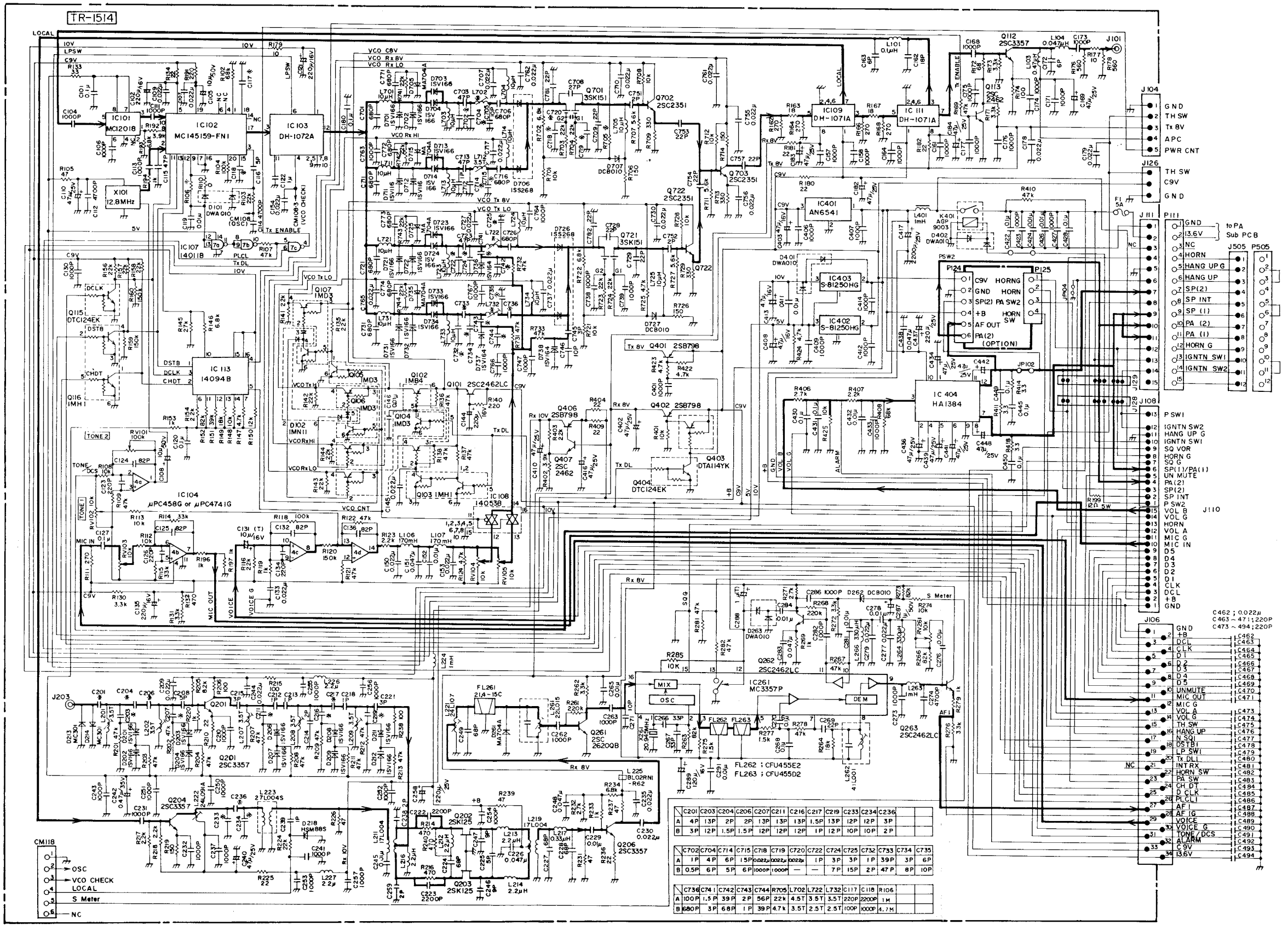

- D101, D263, D402
- Q101, Q113, Q115, Q261, Q262, Q263, Q403, Q404, Q407, Q702, Q703, Q722
- D102
- Q102, Q103, Q104, Q105, Q106, Q107, Q116
- D201, D202, D203, D204, D205, D206, D207, D208, D209, D210, D211, D212, D701, D702, D703, D704, D711, D712, D713, D714, D721, D722, D723, D724, D731, D732, D733, D734, D736, D737, D738
- Q112, Q201, Q206, Q401, Q402
- D218
- Q112, Q201, Q206, Q401, Q402
- D261, D262, D705, D706, D707, D715, D725, D726, D727, D735



A B C D E F G H I J K L M

1  
2  
3  
4  
5  
6  
7  
8

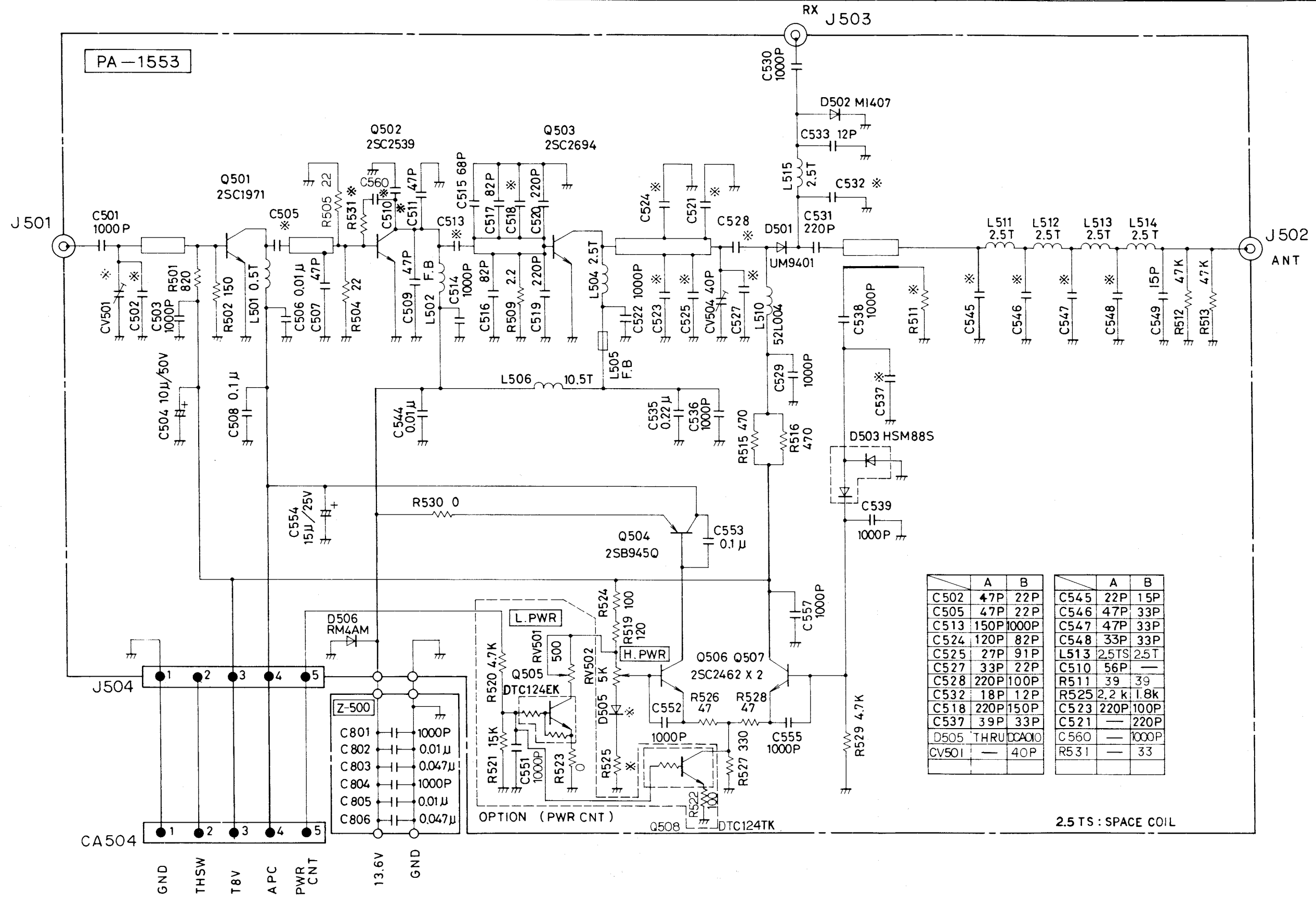

	A	B		A	B
C502	47P	22P	C545	22P	15P
C505	47P	22P	C546	47P	33P
C513	150P	1000P	C547	47P	33P
C524	120P	82P	C548	33P	33P
C525	27P	91P	L513	2.5TS	2.5T
C527	33P	22P	C510	56P	—
C528	220P	100P	R511	39	39
C532	18P	12P	R525	2.2 k	1.8k
C518	220P	150P	C523	220P	100P
C537	39P	33P	C521	—	220P
D505 THRU D506	—	—	C560	—	1000P
CV501	—	40P	R531	—	33

2.5 TS : SPACE COIL

- Q501
- Q502
- Q503
- Q504, Q505
- Q506, Q507
- D503
- D506

TOP VIEW

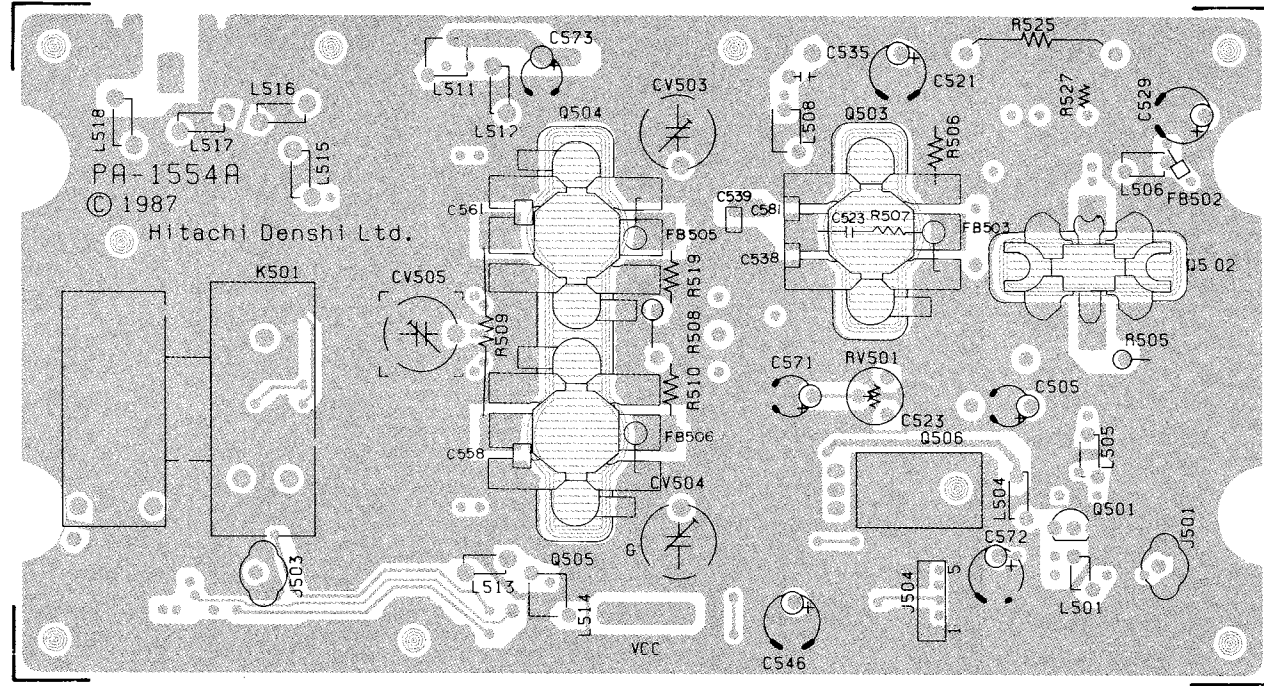

BOTTOM VIEW

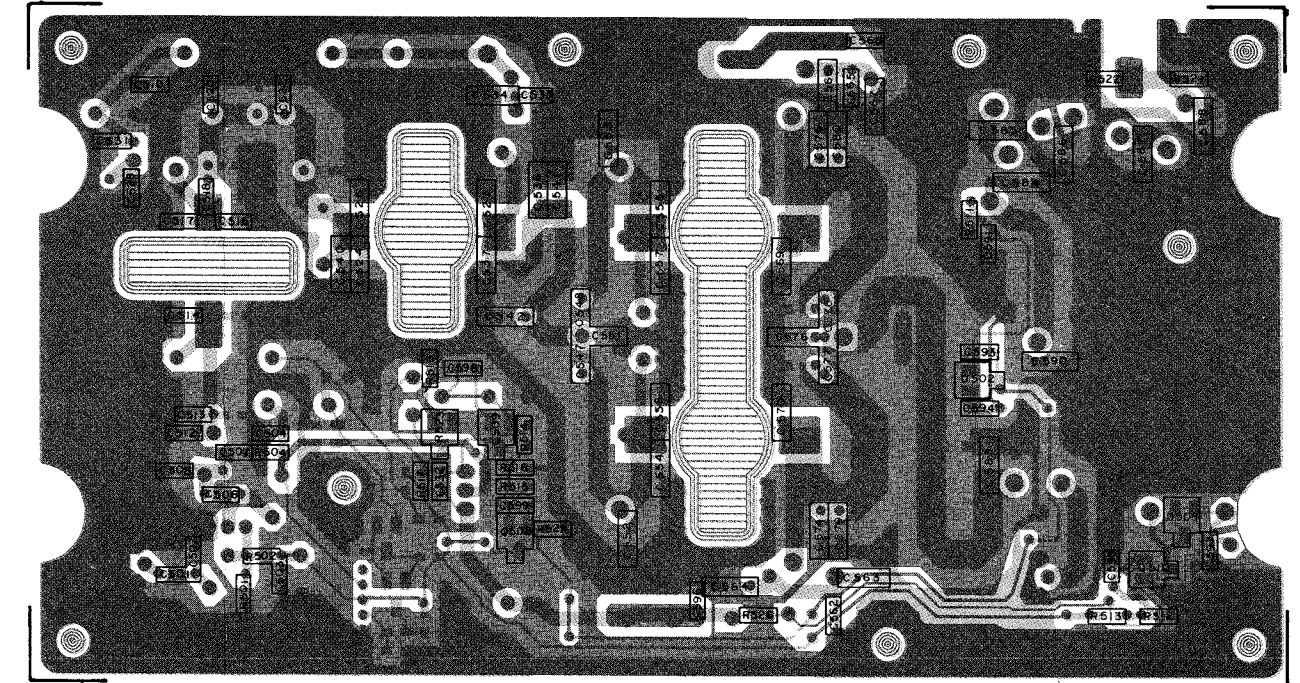
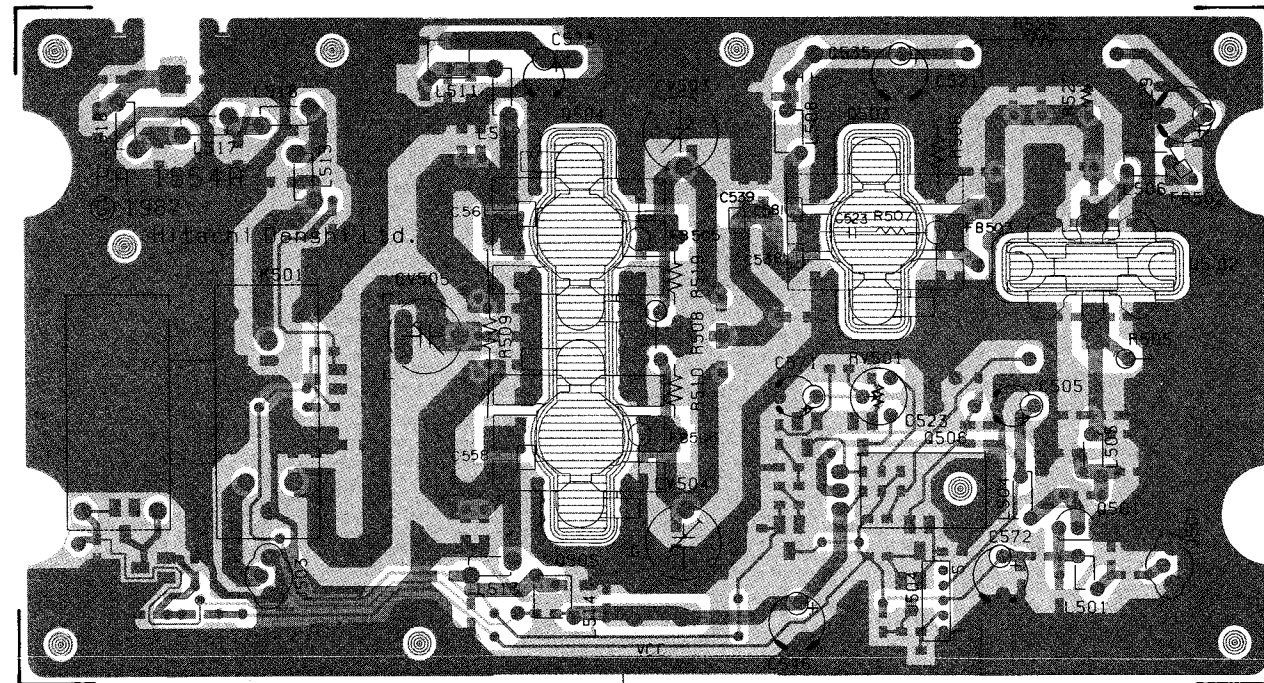
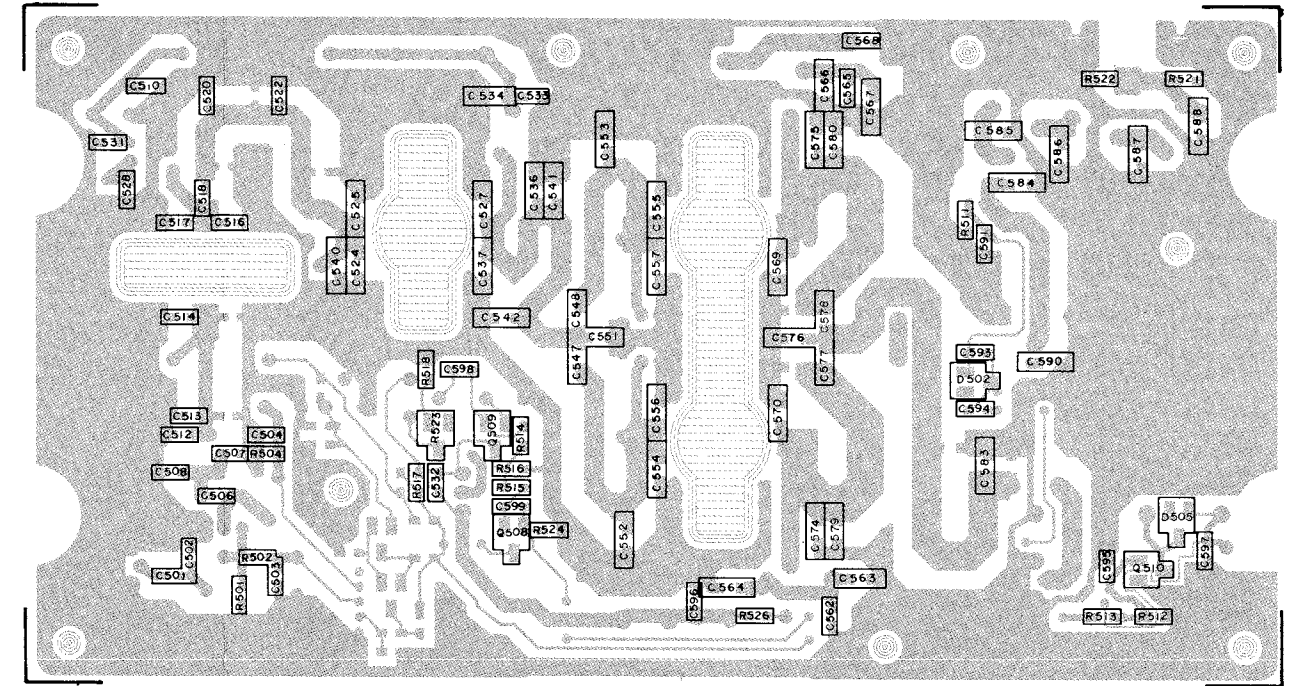

BLUE VISIBLE PLATING

RED UNDERSIDE PLATING

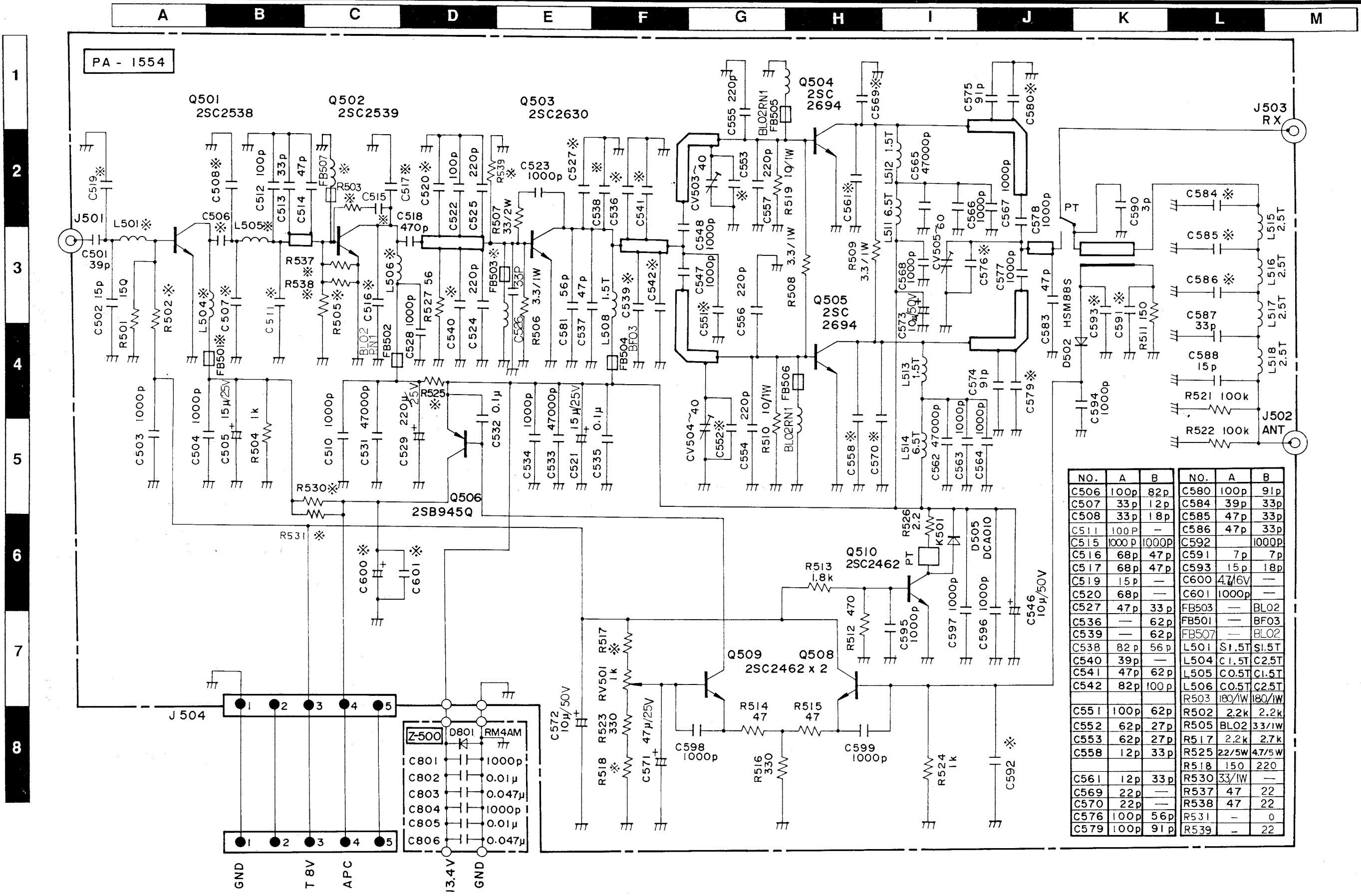

NO.	A	B	NO.	A	B
C506	100p	82p	C580	100p	91p
C507	33p	12p	C584	39p	33p
C508	33p	18p	C585	47p	33p
C511	100p	-	C586	47p	33p
C515	1000p	1000p	C592	-	1000p
C516	68p	47p	C591	7p	7p
C517	68p	47p	C593	15p	18p
C519	15p	-	C600	47/6V	-
C520	68p	-	C601	1000p	-
C527	47p	33p	FB503	-	BL02
C536	-	62p	FB501	-	BF03
C539	-	62p	FB507	-	BL02
C538	82p	56p	L501	S1.5T	S1.5T
C540	39p	-	L504	C1.5T	C2.5T
C541	47p	62p	L505	C0.5T	C1.5T
C542	82p	100p	L506	C0.5T	C2.5T
C551	100p	62p	R503	180/1W	180/1W
C552	62p	27p	R502	2.2k	2.2k
C553	62p	27p	R505	BL02	33/1W
C558	12p	33p	R517	2.2k	2.7k
C561	12p	33p	R525	22/5W	47/5W
C569	22p	-	R518	150	220
C570	22p	-	R530	33/1W	-
C576	100p	56p	R537	47	22
C579	100p	91p	R538	47	22
			R531	-	0
			R539	-	22

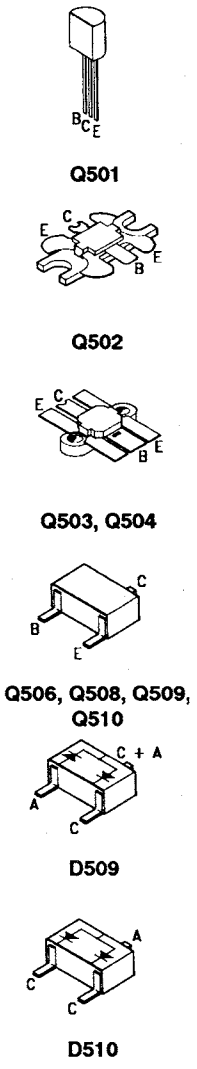

70-3400/3800

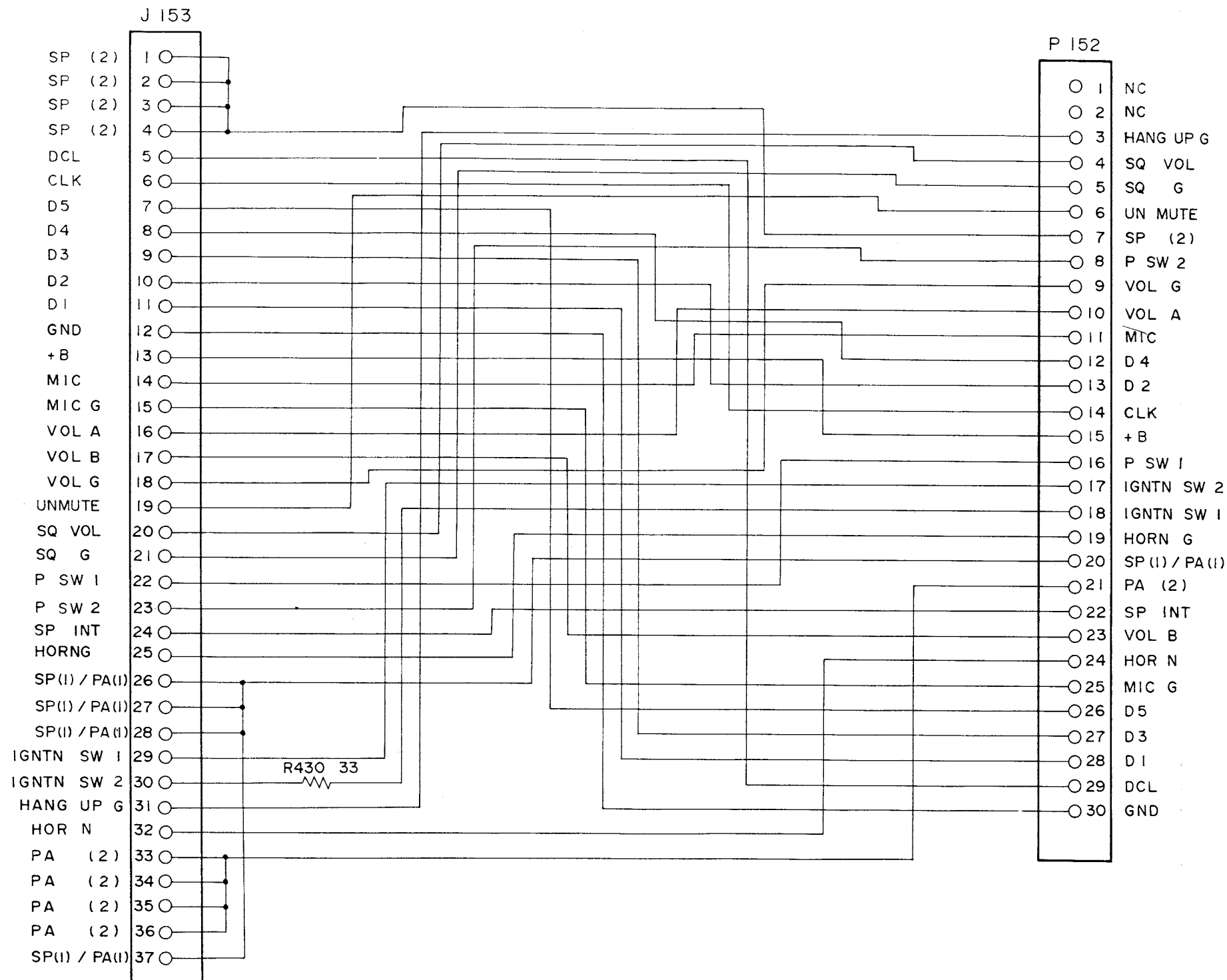

TOP VIEW

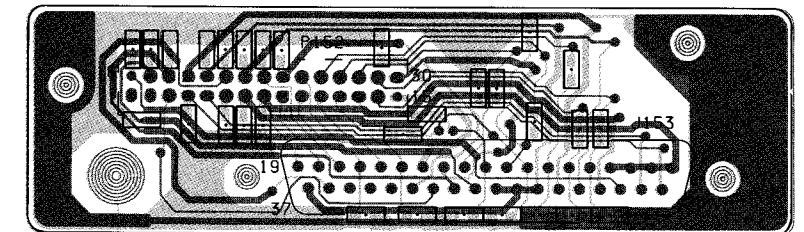
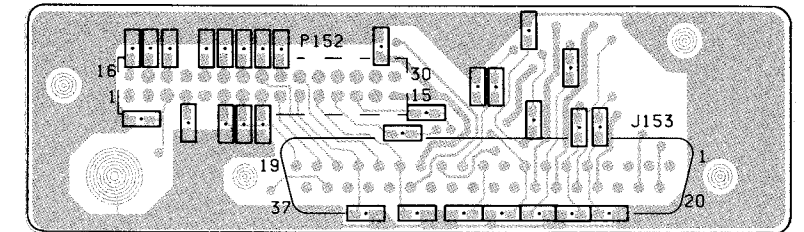

BOTTOM VIEW

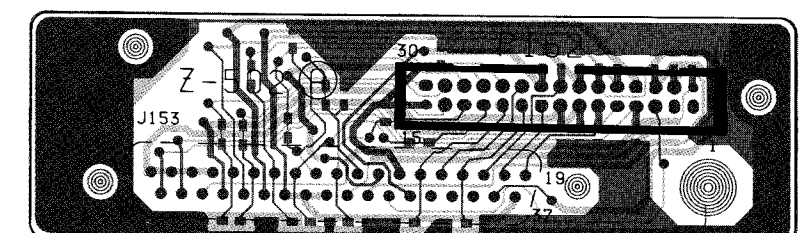
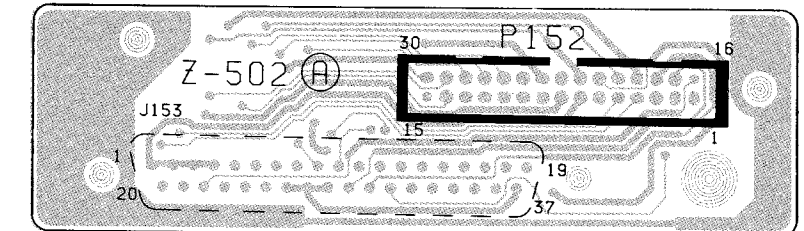

BLUE VISIBLE PLATING  
RED UNDERSIDE PLATING



A B C D E F G H I J K L M

1  
2  
3  
4  
5  
6  
7  
8

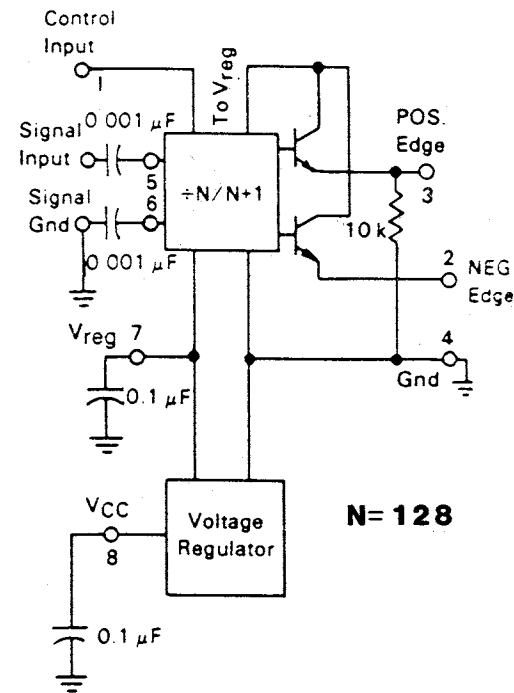

**IC101-MC12018 MODULUS PRESCALER**

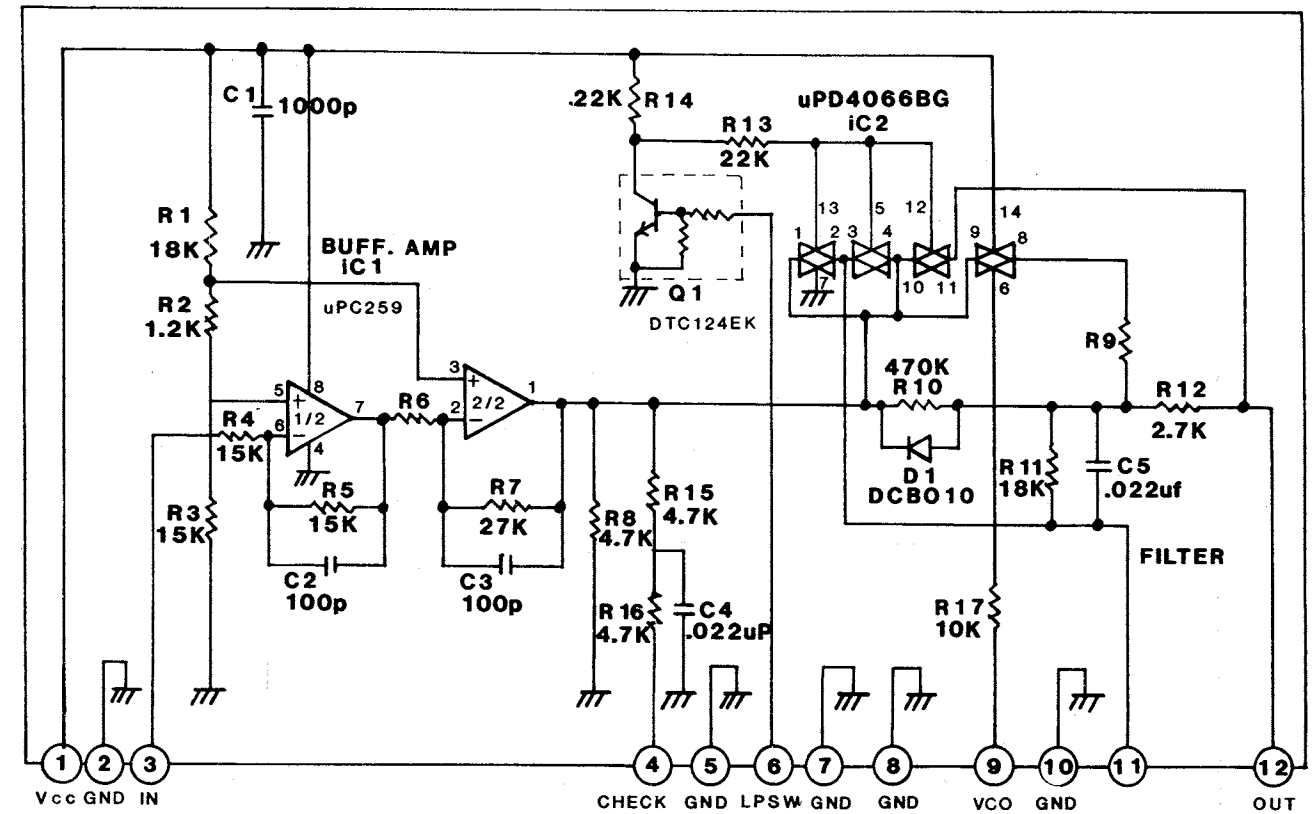

**IC103 - DH-1072A LOOP FILTER**

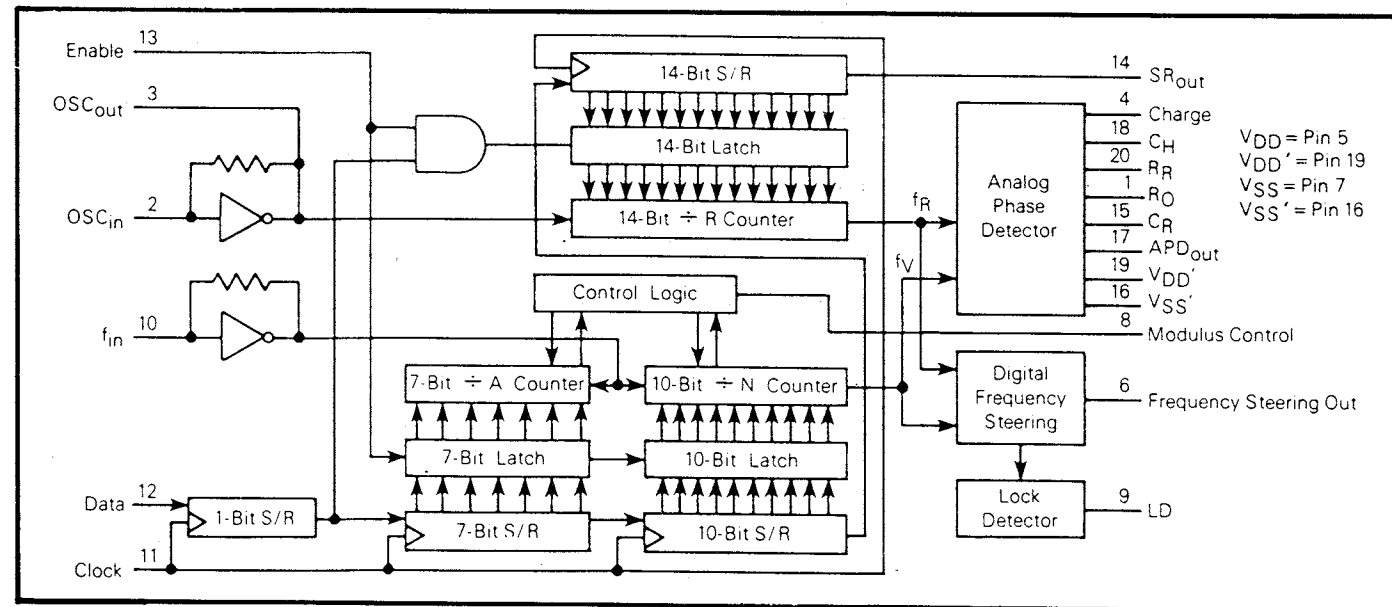

**IC102 - MC145159-FN1 PHASE-LOCK LOOP**

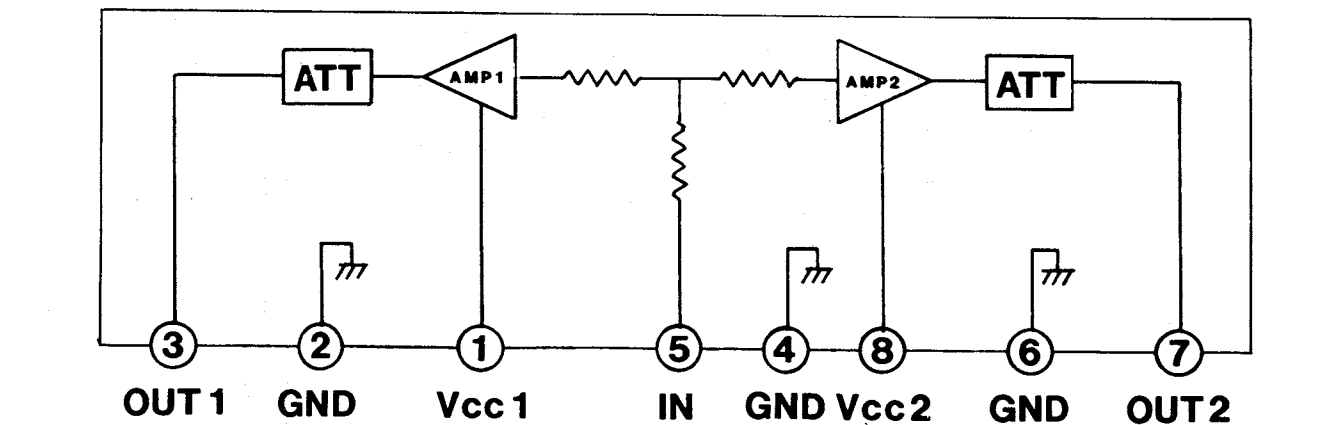

**IC109/IC111 - DH-1071A DUAL RF AMPLIFIER**

A B C D E F G H I J K L M

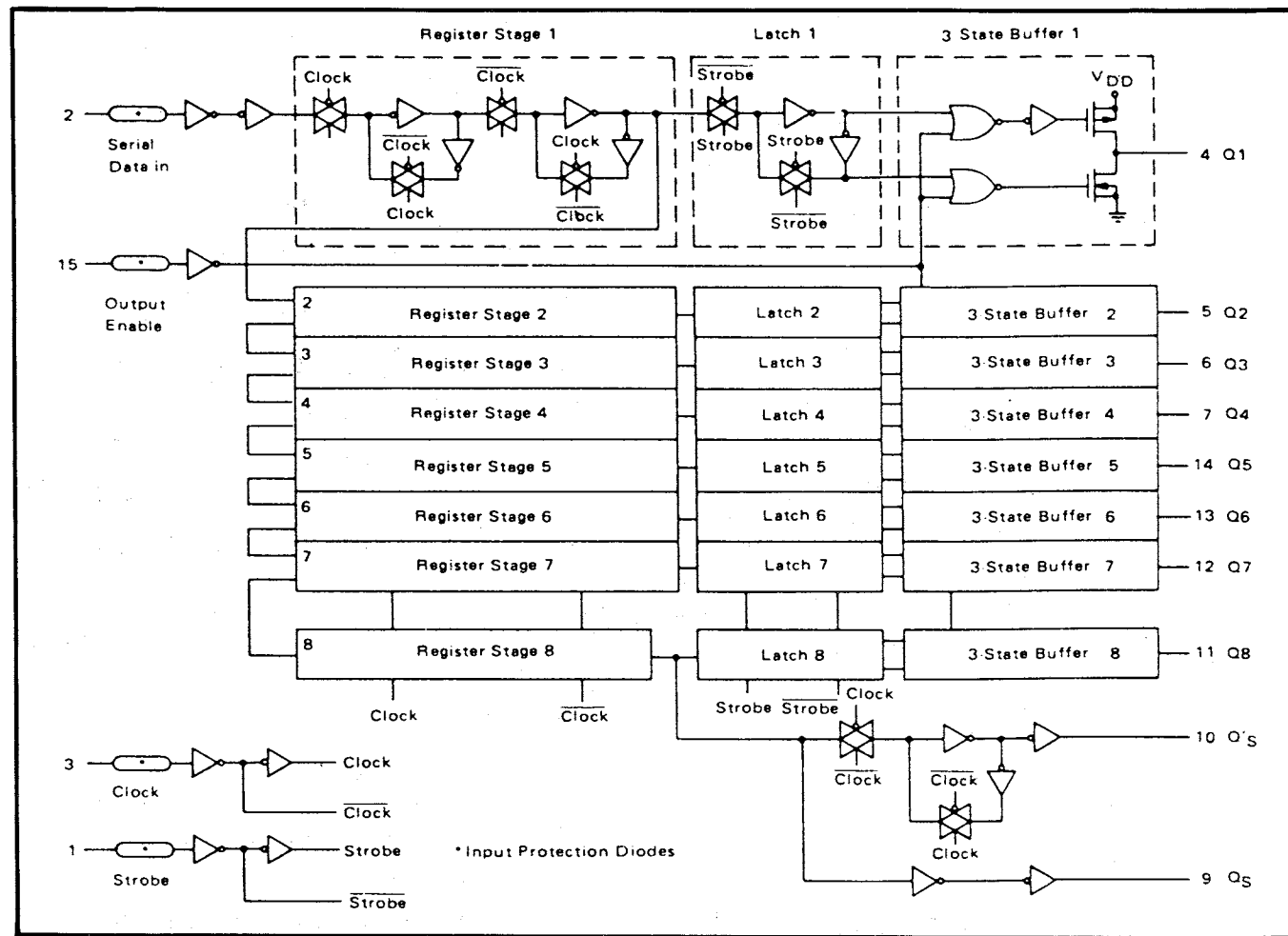

IC113 - MC14094B 8-BIT SHIFT REGISTER

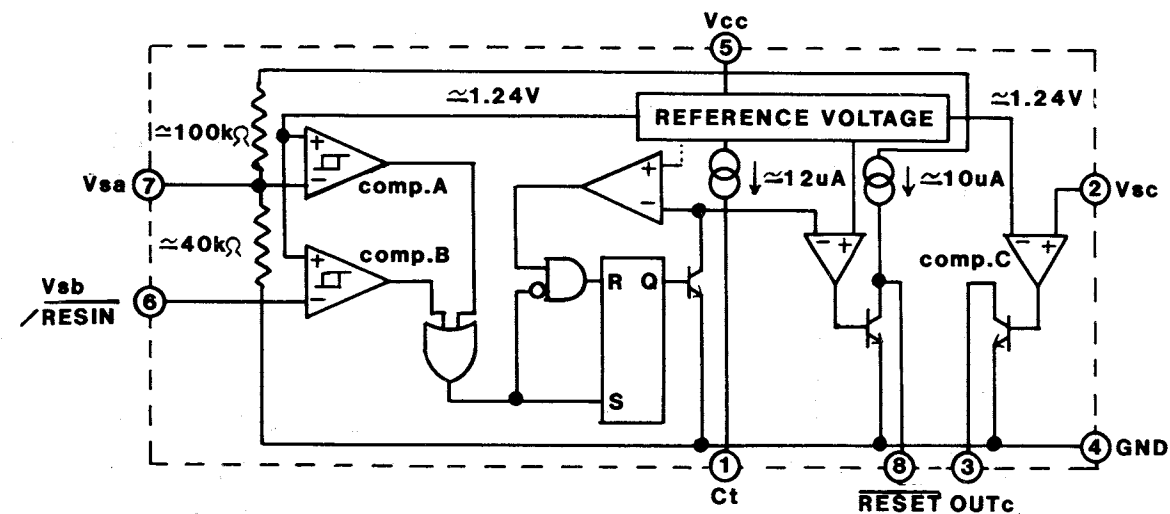

IC904 - MB3771 RESET CONTROLLER

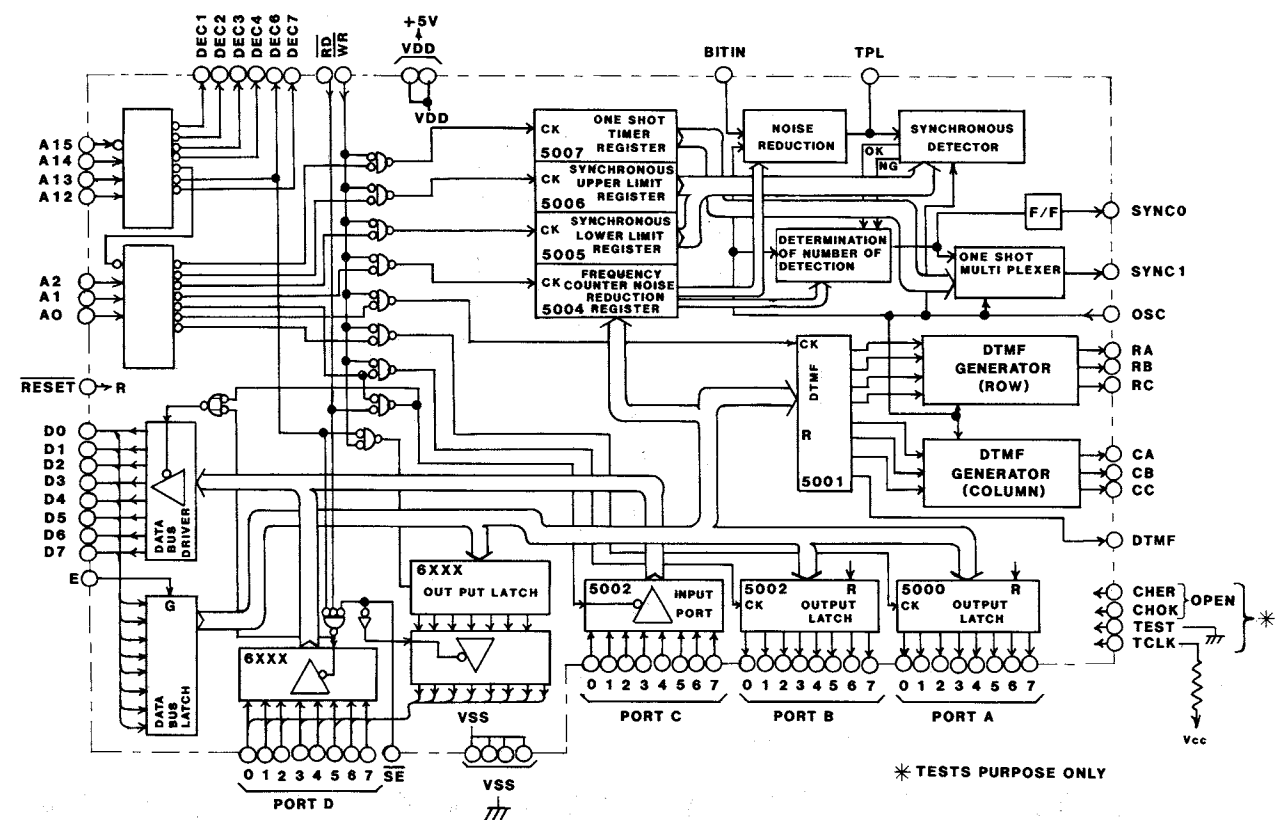

IC901 - HN671106U PERIPHERAL LSIC

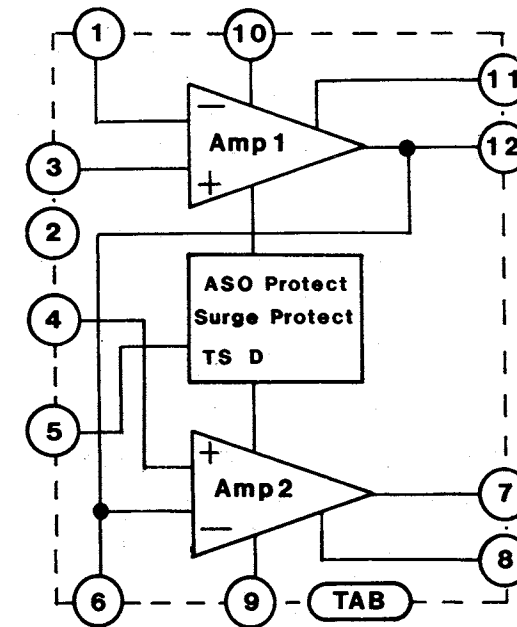

IC404 - HA1384 AUDIO POWER AMPLIFIER

A B C D E F G H I J K L M

1  
2  
3  
4  
5  
6  
7  
8

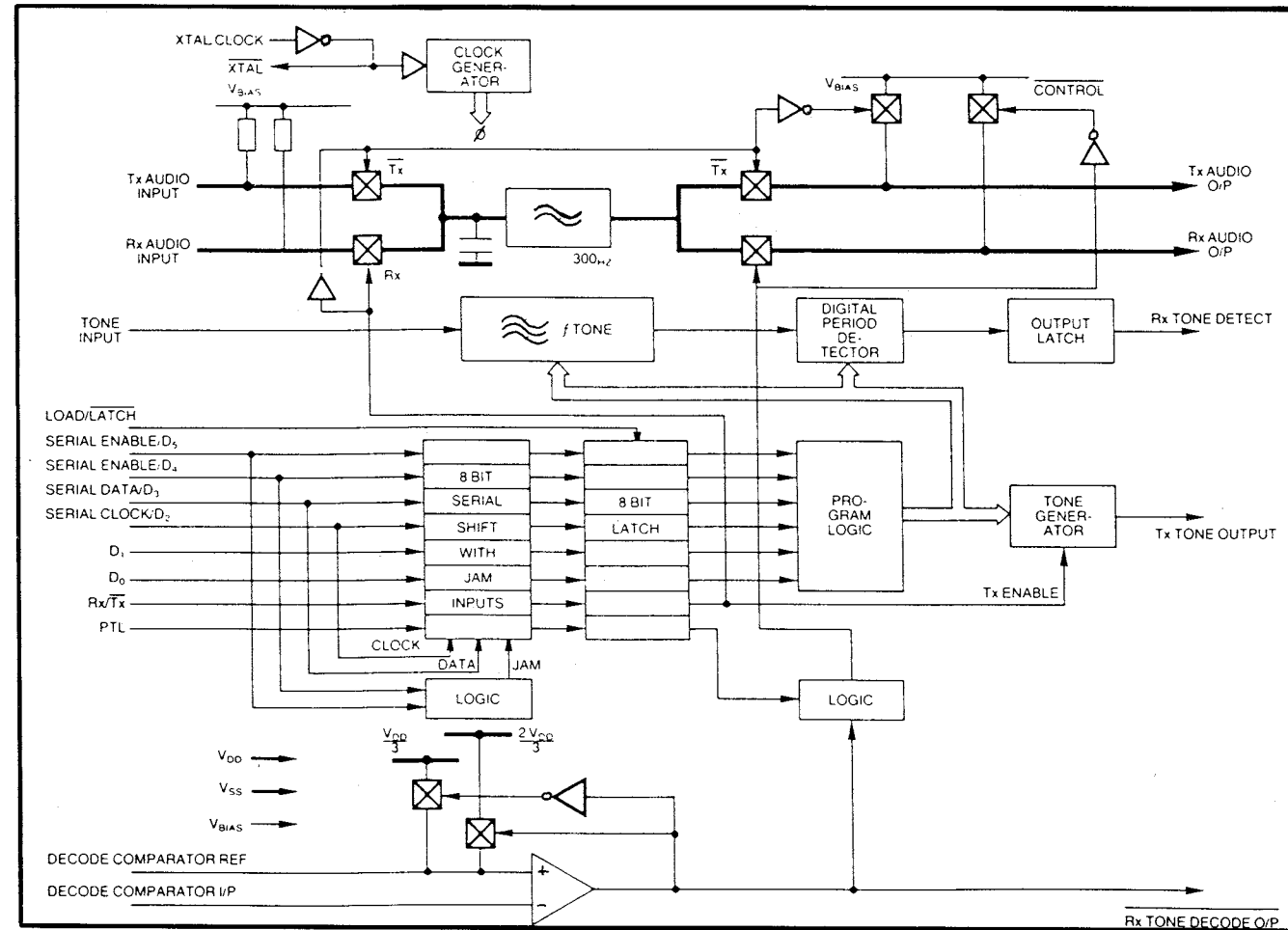

**IC907 - MX365P CTCSS ENCODER/DECODER**

REF NO.	DESCRIPTION	PART NO.
46	U/D BRACKET	70-158255
514	HARD WARE BAG	70-000012

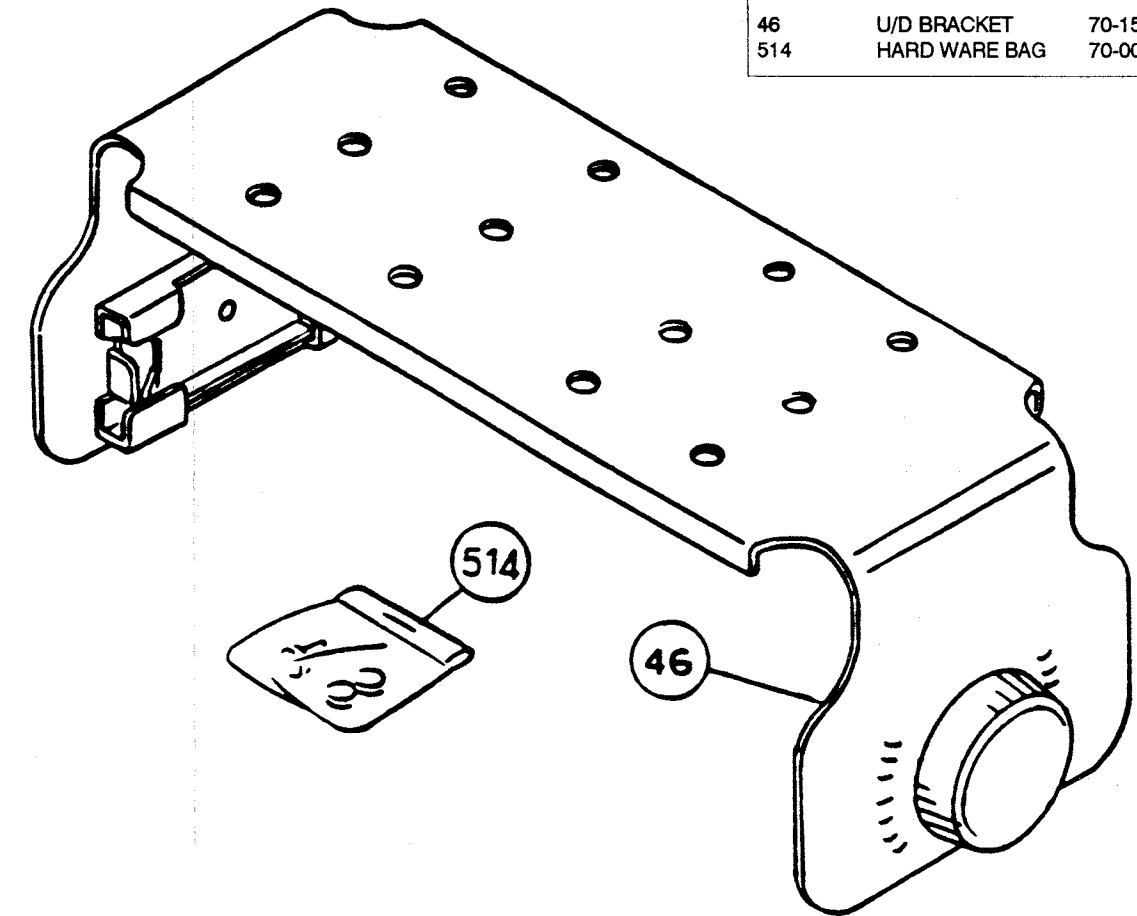

TRUNK-MOUNT BRACKET EXPLODED VIEW

TRUNK-MOUNT NOSE PIECE EXPLODED VIEW

70-3400/3800

A B C D E F G H I J K L M

1  
2  
3  
4  
5  
6  
7  
8

REF NO.	DESCRIPTION	PART NO.
8	CLIP	70-158252
47	T/M BRACKET	70-158256
510	SCREW M3 X 5	70-151840
515	HARD WARE BAG	70-000013

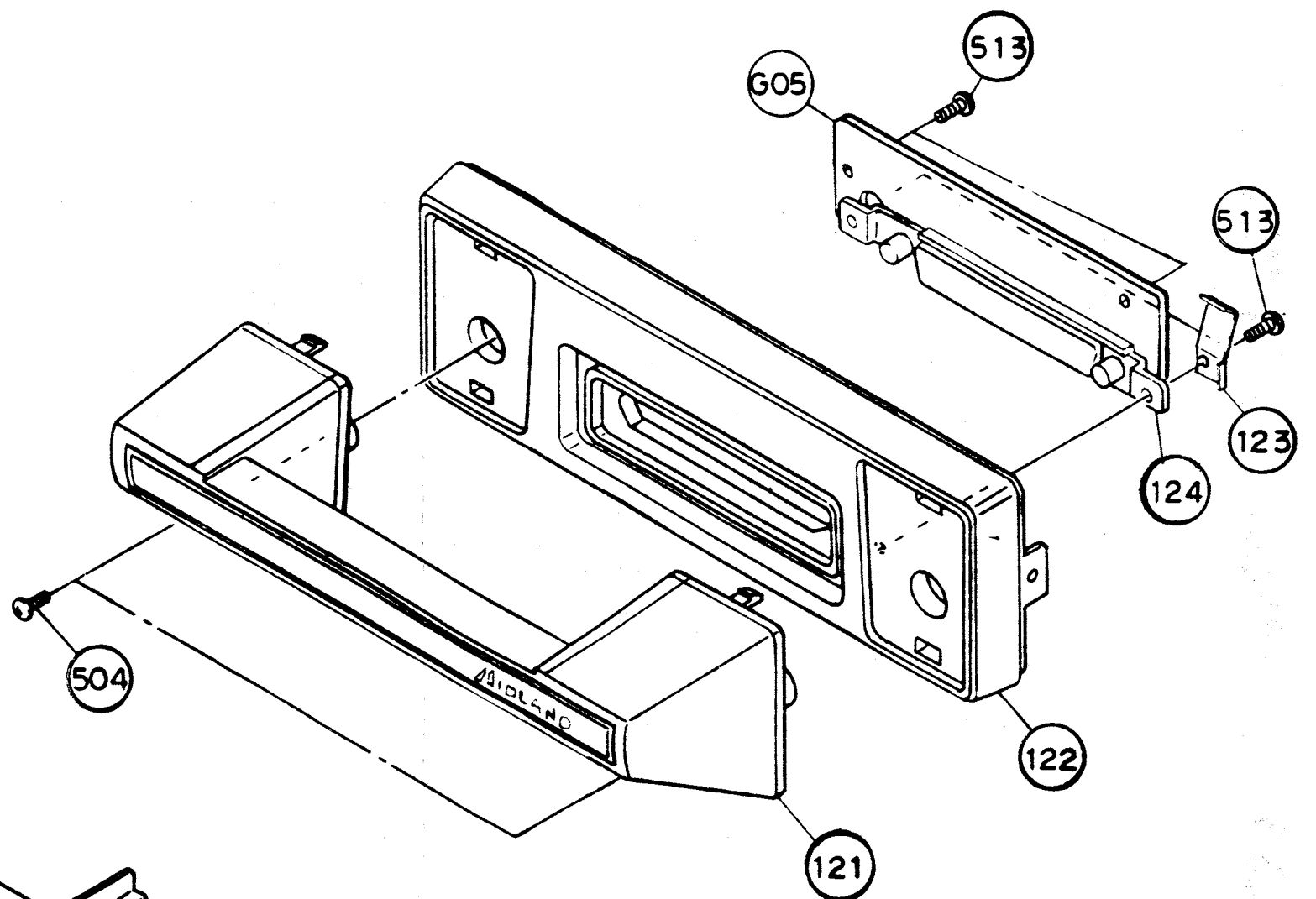
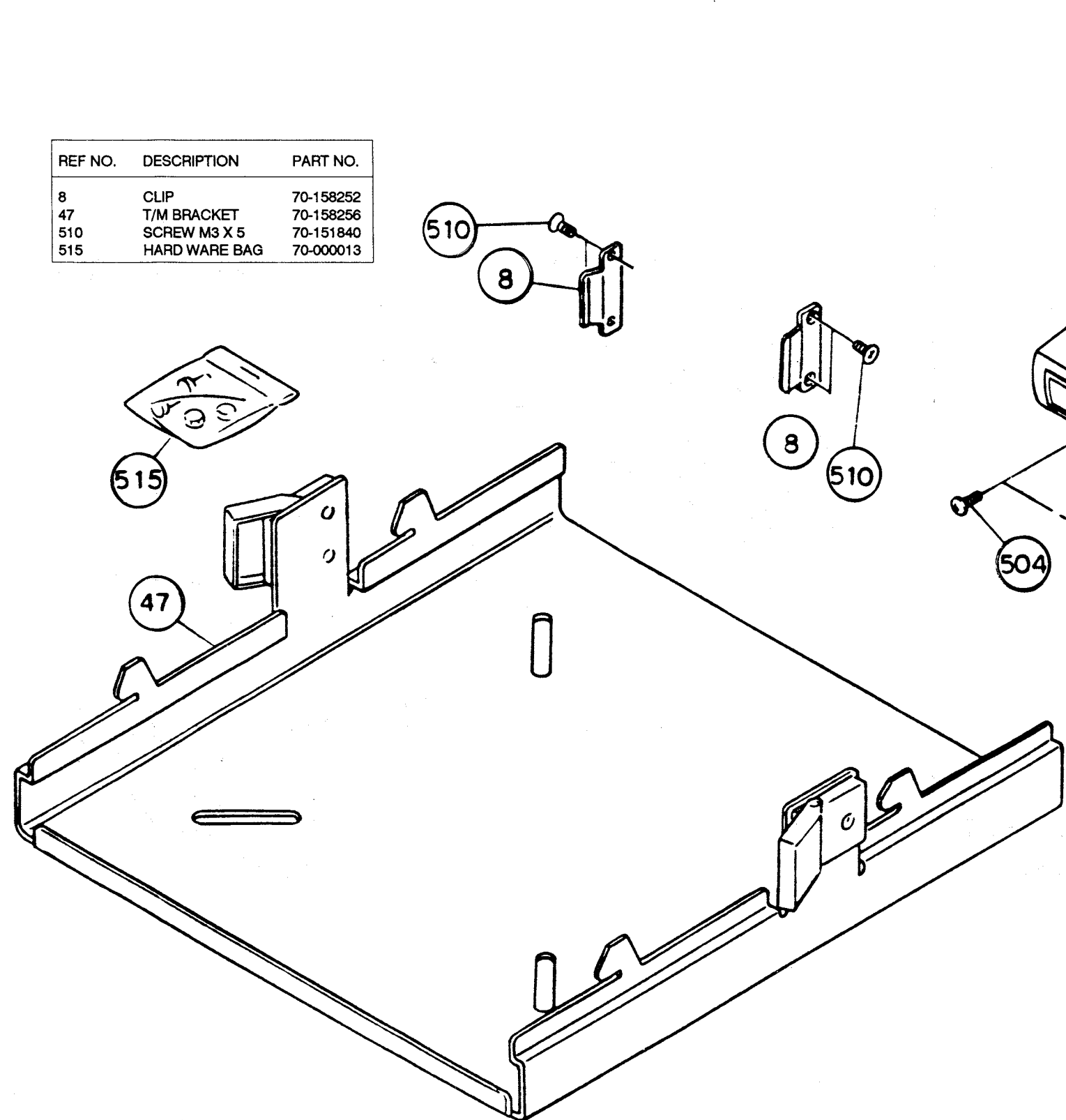

REF NO.	DESCRIPTION	PART NO.
121	HANDLE	70-158259
122	HANDLE BASE	70-158260
123	GROUND PLATE	70-151849
124	BRACKET	70-158261
125	HEX STUD	70-151852
504	SCREW M3 X 8	70-151356
513	SCREW M3 X 8	70-151843
522	WASHER	70-151853
523	WASHER	70-151854

A B C D E F G H I J K L M

1  
2  
3  
4  
5  
6  
7  
8

REF NO.	DESCRIPTION	PART NO.
1	CHASSIS	70-015043
2	VCO CASE	70-010189
3	RUBBER COVER	70-157271
4	TOP COVER	70-010190
5	BOTTOM COVER	70-010191
6	PORT COVER	70-010192
7	SIDE RAIL	70-010193
9	IC BRACKET	70-158253
10	CONNECTOR BRACKET	70-158254
12	GROUND SPRING	70-152095
16	GROUND SPRING	70-152097
17	IF SHIELD	70-089308
18	RF SHIELD	70-089309
21	PA HEATSINK	70-089307
23	PA COVER	70-010194
25	PA INSULATOR	70-010270
26	GROUND CABLE	70-034329
36	GROUND LUG	70-151271
46	U/D BRACKET	70-158255
502	SCREW M3 X6	70-151616
504	SCREW M3 X 2	70-151356
505	SCREW M3 X 8	70-151409
506	SCREW M3 X 12	70-151839
507	SCREW M3 X 8	70-151810
508	SCREW M3 X 10	70-151273
509	SCREW M3 X 12	70-151841
511	SCREW M3 X 10	70-151804
514	HARDWARE BAG	70-000012
G01 A	RF PCB TR 1514A	70-075312
G01 B	RF PCB TR 1514B	70-075374
G02	CX-55	70-075375
G03 A 40	PA-1553A	70-075313
G03 B 40	PA-1553B	70-075326
G03 A 110	PA-1553A	70-075314
G03 B 110	PA-1553B	70-075327
G04	DC FEED THRU Z-500 (INCLUDED IN PA-1553)	
G05	NOSE PIECE CONNECTOR BOARD Z-502	70-075321

A = A-Band Only    40 = 40 W PA  
B = B-Band Only    110 = 110 W PA

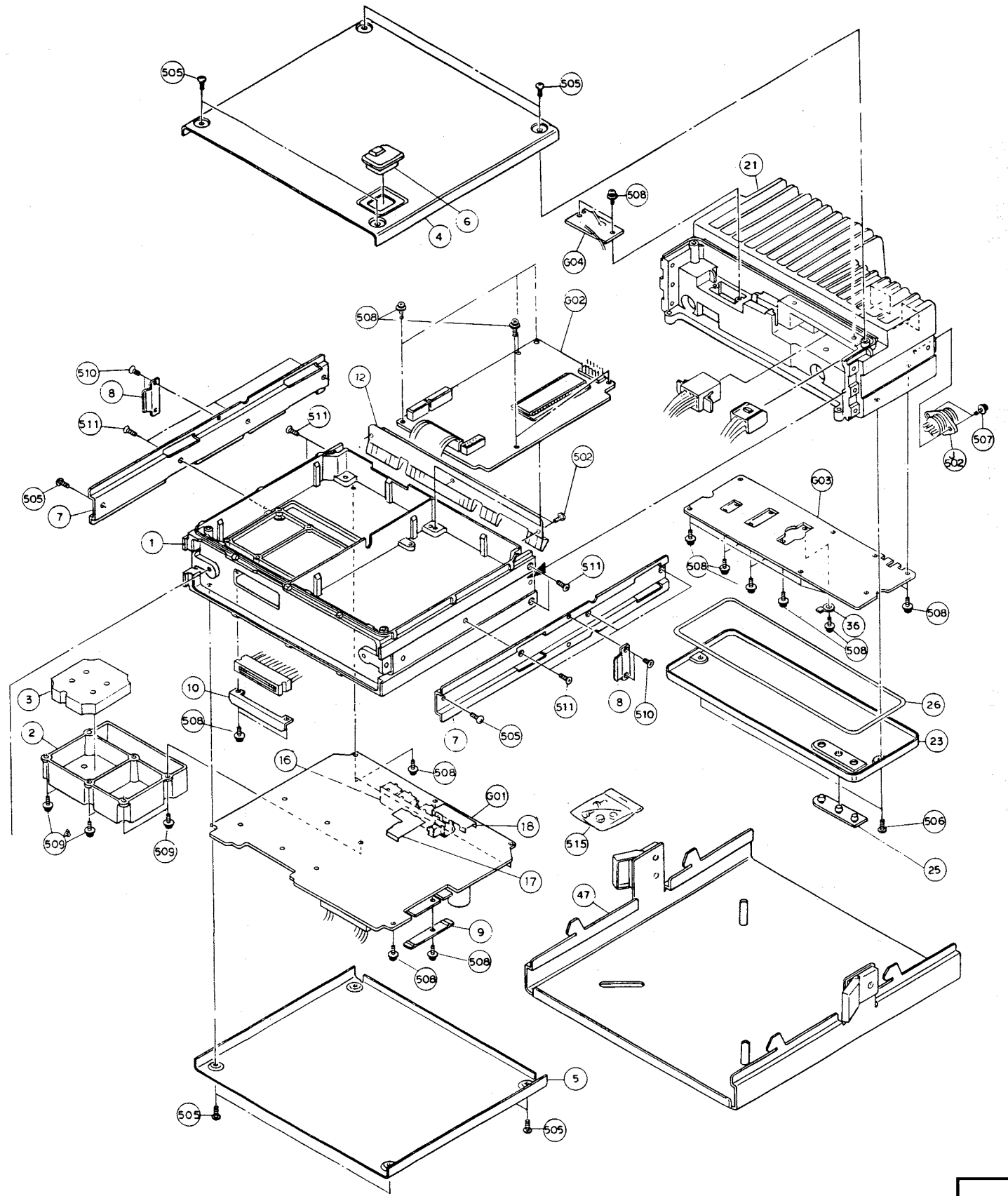

# 70-3800 EXPLODED VIEW

70-3400/3800

A B C D E F G H I J K L M

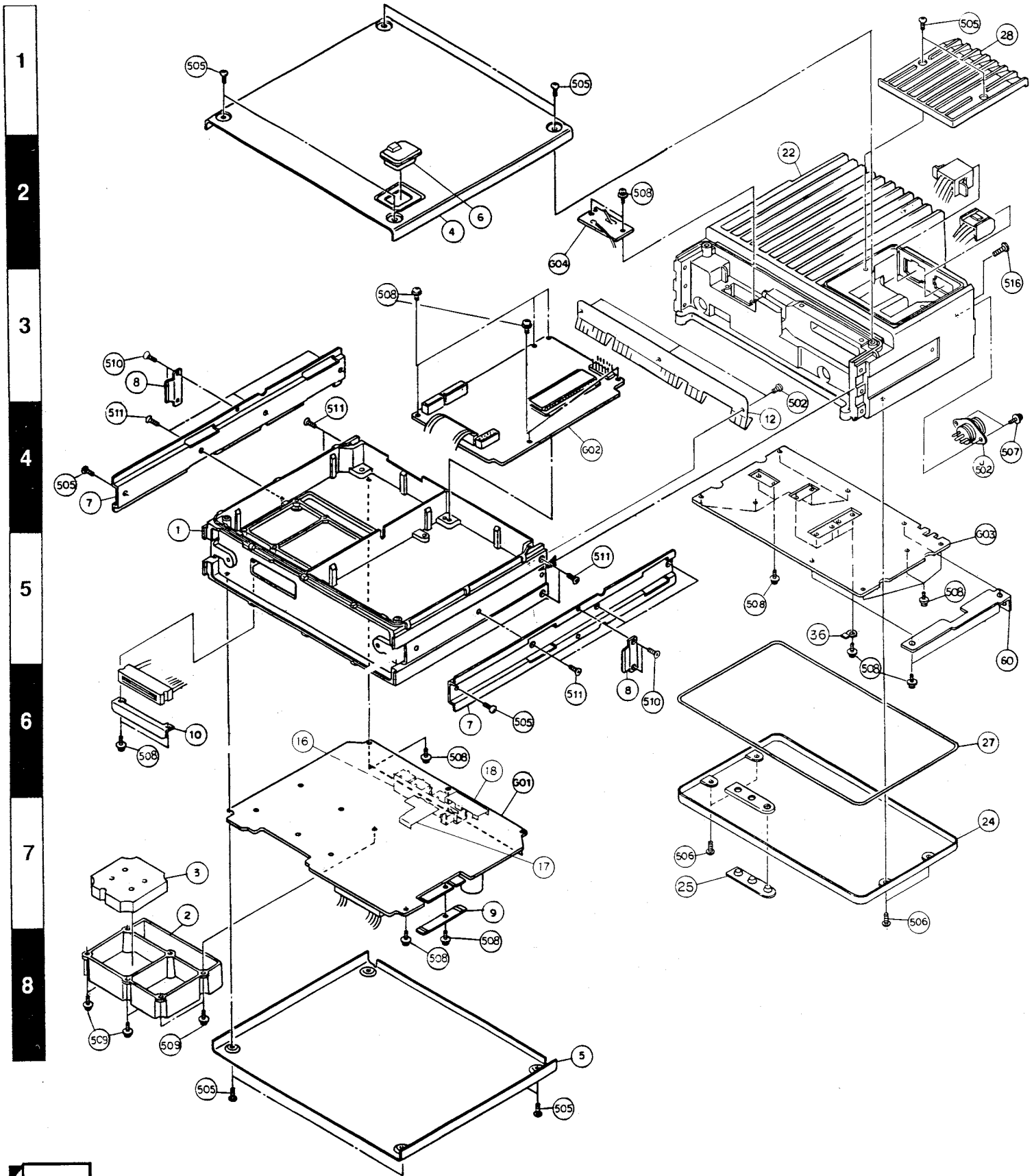

REF NO.	DESCRIPTION	PART NO.
1	CHASSIS	70-015043
2	VCO CASE	70-010189
3	RUBBER COVER	70-157271
4	TOP COVER	70-010190
5	BOTTOM COVER	70-010191
6	PORT COVER	70-010192
7	SIDE RAIL	70-010193
8	BRACKET	70-158252
9	IC BRACKET	70-158253
10	CONNECTOR BRACKET	70-158254
12	GROUND SPRING	70-152095
16	GROUND SPRING	70-152097
17	IF SHIELD	70-089308
18	RF SHIELD	70-089309
21	PA HEATSINK	70-089307
24	PA COVER	70-010187
25	PA INSULATOR	70-010271
27	GROUND CABLE	70-034330
28	CONNECTOR COVER	70-010188
36	GROUND LUG	70-151271
57	T/M BRACKET	70-158256
121	HANDLE	70-158259
122	HANDLE BASE	70-158260
123	GROUND PLATE	70-151849
124	BRACKET	70-158261
125	HEX STUD	70-151852
502	SCREW M3 X6	70-151616
504	SCREW M3 X 2	70-151356
505	SCREW M3 X 8	70-151409
506	SCREW M3 X 12	70-151839
507	SCREW M3 X 8	70-151810
508	SCREW M3 X 10	70-151273
509	SCREW M3 X 12	70-151841
510	SCREW M3 X 4	70-151840
511	SCREW M3 X 10	70-151804
513	SCREW M3 X 8	70-151843
522	WASHER	70-151853
523	WASHER	70-151854
515	HARDWARE BAG	70-000013
516	SCREW M3 X 10	70-151413
G01 A	RF PCB TR 1514A	70-075312
G01 B	RF PCB TR 1514B	70-075374
G02	CX-55	70-075375
G03 A 40	PA-1553A	70-075313
G03 B 40	PA-1553B	70-075326
G03 A 110	PA-1553A	70-075314
G03 B 110	PA-1553B	70-075327
G04	DC FEED THRU Z-500 (INCLUDED IN PA-1553)	
G05	NOSE PIECE CONNECTOR BOARD Z-502	70-075321

**SECTION 6**

**PARTS**

# PARTS

---

70-3400/3800

## NOTES



## MECHANICAL PARTS

REF NO.	DESCRIPTION	PART NO.
1	CHASSIS	70-015043
2	VCO CASE	70-010189
3	RUBBER COVER	70-157271
4	TOP COVER	70-010190
5	BOTTOM COVER	70-010191
6	PORT COVER	70-010192
7	SIDE RAIL	70-010193
8 TM	BRACKET	70-158252
9	IC BRACKET	70-158253
10	CONNECTOR BRACKET	70-158254
12	GROUND SPRING	70-152095
16	GROUND SPRING	70-152097
17	IF SHIELD	70-089308
18	RF SHIELD	70-089309
21	PA HEATSINK	70-089307
23 UD	PA COVER	70-010194
24 TM	PA COVER	70-010187
25 UD	PA INSULATOR	70-010270
25 TM	PA INSULATOR	70-010271
26 UD	GROUND CABLE	70-034329
27 TM	GROUND CABLE	70-034330
28 TM	CONNECTOR COVER	70-010188
38	GROUND LUG	70-151271
46 UD	U/D BRACKET	70-158255
57 TM	T/M BRACKET	70-158256
121 TM	HANDLE	70-158259
122 TM	HANDLE BASE	70-158280
123 TM	GROUND PLATE	70-151849
124 TM	BRACKET	70-158261
125 TM	HEX STUD	70-151852
502	SCREW M3 X6	70-151618
504	SCREW M3 X 2	70-151358
505	SCREW M3 X 8	70-151409
506	SCREW M3 X 12	70-151839
507	SCREW M3 X 8	70-151810
508	SCREW M3 X 10	70-151273
509	SCREW M3 X 12	70-151841
510 TM	SCREW M3 X 4	70-151840
511	SCREW M3 X 10	70-151804
513 TM	SCREW M3 X 8	70-151843
522 TM	WASHER	70-151853
523 TM	WASHER	70-151854
514 UD	HARDWARE BAG	70-000012
515 TM	HARDWARE BAG	70-000013
516 TM	SCREW M3 X 10	70-151413
G01 A	RF PCB TR 1514A	70-075312
G01 B	RF PCB TR 1514B	70-075374
G02	CX-55	70-075375
G03 A 40	PA-1553A	70-075313
G03 B 40	PA-1553B	70-075326
G03 A 110	PA-1553A	70-075314
G03 B 110	PA-1553B	70-075327
G04	DC FEED THRU Z-500 (INCLUDED IN PA-1553)	
G05	NOSE PIECE CONNECTOR BOARD Z-502	70-075321

# PARTS

70-3400/3800

## TR-1514 RF BOARD

A = A-Band Only		T = Topside		B = B-Band Only		U = Underside	
REF NO.	LOC	DESCRIPTION	PART NO.	REF NO.	LOC	DESCRIPTION	PART NO.
CONNECTORS				FILTERS			
CM118		METER JACK	70-159252	FL261	T	21.4—15	70-179072
J101		COAX JACK	70-159089	FL262	T	CFU455E2	70-179019
J104		5 PIN JACK	70-159424	FL263	T	CFU455D2	70-179071
J106		34 PIN JACK	70-159422				
J108		13 PIN JACK	70-159421			CRYSTALS	
J110		15 PIN JACK	70-159423				
J111		15 PIN JACK	70-159425	X101	T	12.8 MHz	70-128080
J203		COAX JACK	70-159089	X261	T	20.945 MHz	70-128081
P124		6 PIN PLUG	70-159426				
P125		4 PIN PLUG	70-159196			CONTROLS	
P126		3 PIN JACK	70-159254				
CABLE ASSEMBLIES							
CA106		34 COND. CABLE	70-034316	RV101	T	TONE 2, 100K	70-164093
CA108		CONNECTOR WIRE	70-034372	RV102	T	TONE 1, 10 K	70-164094
CA141		8 PIN CABLE	70-034317	RV103	T	MIC SENSITIVITY, 10 K	70-164094
				RV104	T	DEVIATION LO CH	70-164094
				RV105	T	DEVIATION HI CH	70-164094
				RV261	T	SQUELCH RANGE	70-164094
INTEGRATED CIRCUITS				DIODES			
IC101	T	MC12018P	70-076460	D101	U	DWA010	70-085246
IC102	T	MC145159FN1	70-076461	D102	T	IMN11	70-085257
IC103	T	DH1072A	70-076462	D201	U	1SV166	70-085159
IC104	T	uPC4741G	70-076463	D202	U	1SV166	70-085159
IC107	T	HD14011BFP	70-076464	D203	U	1SV166	70-085159
IC108	T	HDMC14053BFP	70-076465	D204	U	1SV166	70-085159
IC109	T	DH 1071A	70-076466	D205	U	1SV166	70-085159
IC111	T	DH 1071A	70-076466	D206	U	1SV166	70-085159
IC113	T	MC14094BF	70-076467	D207	U	1SV166	70-085159
IC261	T	MC3357P	70-076138	D208	U	1SV166	70-085159
IC401	T	AN6541	70-076468	D209	U	1SV166	70-085159
IC402	T	S-81250HG	70-076390	D210	U	1SV166	70-085159
IC403	T	S-81250HG	70-076390	D211	U	1SV166	70-085159
IC404	T	HA1384	70-076469	D212	U	1SV166	70-085159
				D213	U	MC301	70-085077
				D214	U	MC301	70-085077
				D218	U	HSM88S	70-085154
				D261	U	MA704A	70-085247
				D262	T	DCB010	70-085245
				D263	T	DWA010	70-085246
				D402	T	DWA010	70-085246
				D701	U	1SV166	70-085159
				D702	U	1SV166	70-085159
				D703	U	1SV166	70-085159
				D704	U	1SV166	70-085159
				D705	T	MA704A	70-085247
				D706	T	1SS268	70-085248
				D707	T	DCB010	70-085245
				D711	U	1SV166	70-085159
				D712	U	1SV166	70-085159
				D713	U	1SV166	70-085159
				D714	U	1SV166	70-085159
				D715	T	MA704A	70-085247
				D721	U	1SV166	70-085159
				D722	U	1SV166	70-085159
				D723	U	1SV166	70-085159
				D724	U	1SV166	70-085159
				D725	T	MA704A	70-085247
				D726	T	1SS268	70-085248
				D727	T	DCB010	70-085245
				D731	U	1SV166	70-085159
				D732	U	1SV166	70-085159
				D733	U	1SV166	70-085159
				D734	U	1SV166	70-085159
				D735	T	MA704A	70-085247
				D736	U	1SV164	70-085249
				D737	U	1SV164	70-085249
				D738	U	1SV164	70-085249
TRANSISTORS							
Q101	T	2SC2462LC	70-080160				
Q102	T	IMB4	70-080295				
Q103	T	IMH1	70-080296				
Q104	T	IMD3	70-080297				
Q105	T	IMD3	70-080297				
Q106	T	IMD3	70-080297				
Q107	T	IMD3	70-080297				
Q112	T	2SC3357	70-080298				
Q113	U	2SC2462LC	70-080160				
Q115	T	DTC124EK	70-080274				
Q116	T	IMH1	70-080296				
Q201	T	2SC3357	70-080298				
Q202	T	2SK125	70-080089				
Q203	T	2SK125	70-080089				
Q204	T	2SC3357	70-080298				
Q206	T	2SC3357	70-080298				
Q261	T	2SC2620QB	70-080161				
Q262	T	2SC2462LC	70-080160				
Q263	T	2SC2462LC	70-080160				
Q401	T	2SB798	70-080164				
Q402	T	2SB798	70-080164				
Q403	T	DTA114YK	70-080301				
Q404	T	DTC124EK	70-080274				
Q406	T	2SB798DK	70-080302				
Q407	U	2SC2462LC	70-080160				
Q701	U	3SK151GR	70-080303				
Q702	T	2SC2351	70-080218				
Q703	T	2SC2351	70-080218				
Q721	U	3SK151GR	70-080303				
Q722	T	2SC2351	70-080218				

## TR-1514 RF BOARD (Continued)

REF NO.	LOC	DESCRIPTION	PART NO.	REF NO.	LOC	DESCRIPTION	PART NO.
COILS				CAPACITORS (Continued)			
L101	T	MLF3216DR10KL	70-090316	C130	U	1000 pF, 50 V, CERAMIC	70-138170
L103	T	ELEY R47	70-090401	C131	T	10 uF, 50 V, TANT ELECT	70-135142
L104	T	Z0.8C8045T	70-090163	C132	U	82 pF, 50 V, CERAMIC	70-138250
L106	T	FS1012S-174K	70-178055	C133	U	22000 pF, 50 V, CERAMIC	70-138162
L107	T	FS1012S-174K	70-178055	C134	U	220 pF, 50 V, CERAMIC	70-138176
L201	T	3.5T	70-090239	C136	U	82 pF, 50 V, CERAMIC	70-138250
L202	T	3.5T	70-090239	C145	T	22000 pF, 50 V, PLASTIC	70-137082
L207	T	3.5T	70-090239	C148	T	0.01 uF, 50 V, CERAMIC	70-138270
L208	T	3.5T	70-090239	C150	U	22000 pF, 50 V, CERAMIC	70-138162
L209	T	3.5T	70-090239	C151	U	0.047 uF, 50 V, CERAMIC	70-131298
L211	T	17L004	70-090114	C152	U	10000 pF, 50 V, CERAMIC	70-138168
L212	T	ELE-Y 2R2	70-090261	C153	U	22000 pF, 50 V, CERAMIC	70-138162
L213	T	52L007	70-090319	C154	U	22000 pF, 50 V, CERAMIC	70-138162
L214	T	52L007	70-090319	C157	U	1000 pF, 50 V, CERAMIC	70-138170
L216	T	ELE-Y 2R2MA	70-090121	C158	U	1000 pF, 50 V, CERAMIC	70-138170
L217	T	ELE-Y R33	70-090400	C161	U	1000 pF, 50 V, CERAMIC	70-138170
L219	T	17L004	70-090114	C162	U	18 pF, 50 V, CERAMIC	70-138206
L221	T	24L107	70-090322	C163	U	6 pF, 50 V, CERAMIC	70-138210
L222	T	24L091A	70-090323	C164	U	1000 pF, 50 V, CERAMIC	70-138170
L223	T	27L004SA	70-090191	C168	U	1000 pF, 50 V, CERAMIC	70-138170
L224	T	ELE-Y102KA	70-090125	C169	T	47 uF, 25 V, AL ELECT	70-135144
L225	T	BLO2RN1-R62	70-090291	C171	U	1000 pF, 50 V, CERAMIC	70-138170
L226	T	ELE-Y 2R2MA	70-090121	C172	U	6 pF, 50 V, CERAMIC	70-138210
L227	T	ELE-Y 2R2MA	70-090121	C173	U	1000 pF, 50 V, CERAMIC	70-138170
L261	T	22L015	70-090240	C174	U	1000 pF, 50 V, CERAMIC	70-138170
L262	T	22L004	70-090112	C175	U	1000 pF, 50 V, CERAMIC	70-138170
L263	T	ELE-Y102KA	70-090125	C176	U	1000 pF, 50 V, CERAMIC	70-138170
L264	T	ELE-Y331KA	70-090124	C177	U	1000 pF, 50 V, CERAMIC	70-138170
L266	T	ELE-Y331KA	70-090124	C178	T	2200 pF, 25 V, CERAMIC	70-138162
L401	T	COIL 1 MH	70-178057	C179	T	2200 pF, 25 V, CERAMIC	70-138162
L701	T	MLF3216E100M-L	70-090324	C180	T	0.1 uF, 100 V, PLASTIC	70-137083
L702	T	MC122 4.5T	70-090237	C182	T	47 uF, 25 V, AL ELECT	70-135144
L703	T	MLF3216E100M-L	70-090324	C183	T	47 uF, 25 V, AL ELECT	70-135144
L704	T	MLF3216E100M-L	70-090324	C184	T	47 uF, 25 V, AL ELECT	70-135144
L705	T	MLF3216E100M-L	70-090324	C201 A	U	4 pF, 50 V, CERAMIC	70-138179
L711	T	MLF3216E100M-L	70-090324	C201 B	U	3 pF, 50 V, CERAMIC	70-138164
L713	T	MLF3216E100M-L	70-090324	C203 B	U	12 pF, 50 V, CERAMIC	70-138209
L714	T	MLF3216E100M-L	70-090324	C203 A	U	13 pF, 50 V, CERAMIC	70-138183
L721	T	MLF3216E100M-L	70-090324	C204 B	U	1.5 pF, 50 V, CERAMIC	70-138180
L722 A	T	MC122 3.5T	70-090235	C204 A	U	2 pF, 50 V, CERAMIC	70-138169
L722 B	T	MC122 2.5T	70-090315	C206 A	U	2 pF, 50 V, CERAMIC	70-138169
L723	T	MLF3216E100M-L	70-090324	C206 B	U	1.5 pF, 50 V, CERAMIC	70-138180
L724	T	MLF3216E100M-L	70-090324	C207 B	U	12 pF, 50 V, CERAMIC	70-138209
L725	T	MLF3216E100M-L	70-090324	C207 A	U	13 pF, 50 V, CERAMIC	70-138183
L731	T	MLF3216E100M-L	70-090324	C208	U	5 pF, 50 V, CERAMIC	70-138166
L732 A	T	MC122 3.5T	70-090235	C209	U	22000 pF, 50 V, CERAMIC	70-138162
L732 B	T	MC122 2.5T	70-090315	C209	T	2200 pF, 25 V, CERAMIC	70-138162
L732	T	MLF3216E100M-L	70-090324	C210	U	1000 pF, 50 V, CERAMIC	70-138170
L733	T	MLF3216E100M-L	70-090324	C210	T	1000 pF, 50 V, CERAMIC	70-138170
L734	T	MLF3216E100M-L	70-090324	C211 A	U	13 pF, 50 V, CERAMIC	70-138183
CAPACITORS				C211 B	U	12 pF, 50 V, CERAMIC	70-138209
C101	U	0.1 uF, 50 V, CERAMIC	70-138249	C212	U	1 pF, 50 V, CERAMIC	70-138174
C102	T	220 uF, 16 V, AL ELECT	70-135164	C213	U	1 pF, 50 V, CERAMIC	70-138174
C104	U	1000 pF, 50 V, CERAMIC	70-138170	C214	U	2 pF, 50 V, CERAMIC	70-138169
C105	T	10 uF, 50 V, AL ELECT	70-135420	C215	U	3 pF, 50 V, CERAMIC	70-138164
C106	U	1000 pF, 50 V, CERAMIC	70-138170	C216 A	U	13 pF, 50 V, CERAMIC	70-138183
C107	U	22000 pF, 50 V, CERAMIC	70-138162	C216 B	U	12 pF, 50 V, CERAMIC	70-138209
C108	T	10 uF, 50 V, AL ELECT	70-135142	C217 B	U	1 pF, 50 V, CERAMIC	70-138174
C109	U	22000 pF, 50 V, CERAMIC	70-138162	C217 A	U	1.5 pF, 50 V, CERAMIC	70-138180
C111	U	1000 pF, 50 V, CERAMIC	70-138170	C218	U	1 pF, 50 V, CERAMIC	70-138174
C112	U	4700 pF, 50 V, CERAMIC	70-138163	C219 A	U	13 pF, 50 V, CERAMIC	70-138183
C114	U	4700 pF, 50 V, CERAMIC	70-138163	C219 B	U	12 pF, 50 V, CERAMIC	70-138209
C115	U	47 pF, 50 V, CERAMIC	70-138185	C221	U	3 pF, 50 V, CERAMIC	70-138164
C116	U	5 pF, 50 V, CERAMIC	70-138166	C222	U	2200 pF, 50 V, CERAMIC	70-138235
C117	U	220 pF, 50 V, CERAMIC	70-138176	C223	U	2200 pF, 50 V, CERAMIC	70-138235
C118	U	2200 pF, 50 V, CERAMIC	70-138235	C224	U	68 pF, 50 V, CERAMIC	70-138229
C119	U	10000 pF, 50 V, CERAMIC	70-138168	C225	U	5 pF, 50 V, CERAMIC	70-138166
C120	U	0.1 uF, 50 V, CERAMIC	70-138249	C226	U	0.047 uF, 50 V, CERAMIC	70-131298
C121	T	220 uF, 16 V, AL ELECT	70-137065	C227	U	68 pF, 50 V, CERAMIC	70-138229
C122	T	1 uF, 200 V, PLASTIC	70-137081	C228	U	68 pF, 50 V, CERAMIC	70-138229
C123	U	220 pF, 50 V, CERAMIC	70-138176	C229	U	10000 pF, 50 V, CERAMIC	70-138168
C124	U	82 pF, 50 V, CERAMIC	70-138250	C230	U	22000 pF, 50 V, CERAMIC	70-138162
C125	U	82 pF, 50 V, CERAMIC	70-138250	C231	U	1000 pF, 50 V, CERAMIC	70-138170
C126	U	220 pF, 50 V, CERAMIC	70-138176	C232	U	1000 pF, 50 V, CERAMIC	70-138170
C127	U	0.1 uF, 50 V, CERAMIC	70-138249	C233 B	U	10 pF, 50 V, CERAMIC	70-138167
				C233 A	U	12 pF, 50 V, CERAMIC	70-138209
				C234 A	U	12 pF, 50 V, CERAMIC	70-138209
				C234 B	U	10 pF, 50 V, CERAMIC	70-138167

# PARTS

70-3400/3800

## TR-1514 RF BOARD (Continued)

REF NO.	LOC	DESCRIPTION	PART NO.	REF NO.	LOC	DESCRIPTION	PART NO.
CAPACITORS (Continued)				CAPACITORS (Continued)			
C235	T	2200 pF, 25 V, CERAMIC	70-138162	C439	T	47 uF, 25 V, AL ELECT	70-135168
C235	U	22000 pF, 50 V, CERAMIC	70-138162	C441	T	47 uF, 25 V, AL ELECT	70-135144
C236 B	U	2 pF, 50 V, CERAMIC	70-138169	C442	T	47 uF, 25 V, AL ELECT	70-135144
C236 A	U	12 pF, 50 V, CERAMIC	70-138164	C445	U	0.1 uF, 50 V, CERAMIC	70-138249
C237	U	1000 pF, 50 V, CERAMIC	70-138170	C448	T	47 uF, 25 V, AL ELECT	70-135144
C238	T	2 pF, 50 V, CERAMIC	70-138169	C449	U	0.1 uF, 50 V, CERAMIC	70-138249
C239	U	1 pF, 50 V, CERAMIC	70-138174	C450	T	0.1 uF, 50 V, CERAMIC	70-138249
C240	T	47 uF, 25 V, AL ELECT	70-135144	C452	T	2.2 uF, 50 V, AL ELECT	70-135171
C241	U	1000 pF, 50 V, CERAMIC	70-138170	C482	U	22000 pF, 50 V, CERAMIC	70-138162
C242	T	0.47 uF, 35 V, TANT ELECT	70-135094	C483	U	220 pF, 50 V, CERAMIC	70-138178
C243	U	1000 pF, 50 V, CERAMIC	70-138170	C484	U	220 pF, 50 V, CERAMIC	70-138178
C244	U	22000 pF, 50 V, CERAMIC	70-138162	C485	U	220 pF, 50 V, CERAMIC	70-138178
C245	U	10000 pF, 50 V, CERAMIC	70-138168	C486	U	220 pF, 50 V, CERAMIC	70-138178
C246	U	9 pF, 50 V, CERAMIC	70-138186	C487	U	220 pF, 50 V, CERAMIC	70-138178
C247	U	9 pF, 50 V, CERAMIC	70-138186	C488	U	220 pF, 50 V, CERAMIC	70-138178
C248	U	0.047 uF, 50 V, CERAMIC	70-131298	C489	U	220 pF, 50 V, CERAMIC	70-138178
C249	U	68 pF, 50 V, CERAMIC	70-138229	C470	U	220 pF, 50 V, CERAMIC	70-138178
C250	U	1000 pF, 50 V, CERAMIC	70-138170	C471	U	220 pF, 50 V, CERAMIC	70-138178
C251	U	1000 pF, 50 V, CERAMIC	70-138170	C473	T	220 pF, 50 V, CERAMIC	70-138178
C252	U	1000 pF, 50 V, CERAMIC	70-138170	C474	T	220 pF, 50 V, CERAMIC	70-138178
C253	T	1000 pF, 50 V, CERAMIC	70-138170	C475	T	220 pF, 50 V, CERAMIC	70-138178
C254	T	1000 pF, 50 V, CERAMIC	70-138170	C476	T	220 pF, 50 V, CERAMIC	70-138178
C255	U	1000 pF, 50 V, CERAMIC	70-138170	C477	T	220 pF, 50 V, CERAMIC	70-138178
C256	U	1000 pF, 50 V, CERAMIC	70-138170	C478	T	220 pF, 50 V, CERAMIC	70-138178
C257	U	1000 pF, 50 V, CERAMIC	70-138170	C479	T	220 pF, 50 V, CERAMIC	70-138178
C258	T	220 uF, 25 V, AL ELECT	70-135168	C480	T	220 pF, 50 V, CERAMIC	70-138178
C259	T	2 pF, 50 V, CERAMIC	70-138169	C481	T	220 pF, 50 V, CERAMIC	70-138178
C262	U	1000 pF, 50 V, CERAMIC	70-138170	C482	T	220 pF, 50 V, CERAMIC	70-138178
C263	U	1000 pF, 50 V, CERAMIC	70-138170	C483	T	220 pF, 50 V, CERAMIC	70-138178
C265	U	10000 pF, 50 V, CERAMIC	70-138188	C484	T	220 pF, 50 V, CERAMIC	70-138178
C266	U	33 pF, 50 V, CERAMIC	70-138188	C485	T	220 pF, 50 V, CERAMIC	70-138178
C267	U	33 pF, 50 V, CERAMIC	70-138188	C486	T	220 pF, 50 V, CERAMIC	70-138178
C268	U	0.1 uF, 50 V, CERAMIC	70-138249	C487	T	220 pF, 50 V, CERAMIC	70-138178
C269	U	22 pF, 50 V, CERAMIC	70-138171	C488	T	220 pF, 50 V, CERAMIC	70-138178
C270	U	0.1 uF, 50 V, CERAMIC	70-138249	C489	T	220 pF, 50 V, CERAMIC	70-138178
C273	U	1000 pF, 50 V, CERAMIC	70-138170	C490	T	220 pF, 50 V, CERAMIC	70-138178
C274	U	4700 pF, 50 V, CERAMIC	70-138163	C491	T	220 pF, 50 V, CERAMIC	70-138178
C276	U	10000 pF, 50 V, CERAMIC	70-138168	C492	T	220 pF, 50 V, CERAMIC	70-138178
C277	U	22000 pF, 50 V, CERAMIC	70-138162	C493	T	220 pF, 50 V, CERAMIC	70-138178
C278	U	10000 pF, 50 V, CERAMIC	70-138168	C494	T	220 pF, 50 V, CERAMIC	70-138178
C279	U	22000 pF, 50 V, CERAMIC	70-138162	C701	T	680 pF, 50 V, CERAMIC	70-138252
C281	U	10000 pF, 50 V, CERAMIC	70-138168	C702 B	U	0.5 pF, 50 V, CERAMIC	70-138182
C282	U	1000 pF, 50 V, CERAMIC	70-138170	C702 A	U	1 pF, 50 V, CERAMIC	70-138174
C283	U	0.047 uF, 50 V, CERAMIC	70-131298	C703	U	47 pF, 50 V, CERAMIC	70-138185
C284	U	10000 pF, 50 V, CERAMIC	70-138168	C704 B	U	6 pF, 50 V, CERAMIC	70-138210
C286	U	1000 pF, 50 V, CERAMIC	70-138151	C704 A	U	4 pF, 50 V, CERAMIC	70-138179
C287	T	1 uF, 50 V, AL ELECT	70-135147	C705	U	10 pF, 50 V, CERAMIC	70-138187
C288	T	0.047 uF, 35 V, TANT ELECT	70-138133	C706	T	680 pF, 50 V, CERAMIC	70-138252
C289	T	120 uF, 16 V, AL ELECT	70-135167	C707	T	2200 pF, 25 V, CERAMIC	70-138162
C291	U	10000 pF, 50 V, CERAMIC	70-138168	C708	U	27 pF, 50 V, CERAMIC	70-138165
C401	U	1000 pF, 50 V, CERAMIC	70-138170	C709	U	22 pF, 50 V, CERAMIC	70-138171
C402	T	47 uF, 25 V, AL ELECT	70-135144	C710	T	2200 pF, 25 V, CERAMIC	70-138162
C403	T	4.7 uF, 16 V, AL ELECT	70-135172	C711	T	680 pF, 50 V, CERAMIC	70-138252
C406	U	1000 pF, 50 V, CERAMIC	70-138170	C712	U	1 pF, 50 V, CERAMIC	70-138174
C407	U	1000 pF, 50 V, CERAMIC	70-138170	C713	U	47 pF, 50 V, CERAMIC	70-138185
C408	T	4.7 uF, 16 V, AL ELECT	70-135172	C714 B	U	5 pF, 50 V, CERAMIC	70-138166
C409	U	1000 pF, 50 V, CERAMIC	70-138170	C714 A	U	8 pF, 50 V, CERAMIC	70-138210
C410	T	47 uF, 25 V, AL ELECT	70-135144	C715 B	U	6 pF, 50 V, CERAMIC	70-138210
C411	U	10000 pF, 50 V, CERAMIC	70-138168	C715 A	U	15 pF, 50 V, CERAMIC	70-138205
C412	U	1000 pF, 50 V, CERAMIC	70-138170	C716	T	680 pF, 50 V, CERAMIC	70-138252
C413	T	4.7 uF, 16 V, AL ELECT	70-135172	C717	T	2200 pF, 25 V, CERAMIC	70-138162
C414	U	1000 pF, 50 V, CERAMIC	70-138170	C718 B	U	1000 pF, 50 V, CERAMIC	70-138170
C416	T	47 uF, 25 V, AL ELECT	70-135144	C718 A	U	0.022 pF, 50 V, CERAMIC	70-138162
C417	T	2200 uF, 25 V, AL ELECT	70-135169	C719 B	U	1000 pF, 50 V, CERAMIC	70-138170
C422	U	0.1 uF, 50 V, CERAMIC	70-138249	C719 A	U	0.022 pF, 50 V, CERAMIC	70-138162
C426	U	10000 pF, 50 V, CERAMIC	70-138168	C720	U	22000 pF, 50 V, CERAMIC	70-138162
C427	U	1000 pF, 50 V, CERAMIC	70-138170	C721	T	680 pF, 50 V, CERAMIC	70-138252
C428	U	0.1 uF, 50 V, CERAMIC	70-138249	C722	U	1 pF, 50 V, CERAMIC	70-138174
C430	U	0.1 uF, 50 V, CERAMIC	70-138249	C723	U	47 pF, 50 V, CERAMIC	70-138185
C432	U	10000 pF, 50 V, CERAMIC	70-138168	C724 A	U	3 pF, 50 V, CERAMIC	70-138164
C433	U	1000 pF, 50 V, CERAMIC	70-138170	C724 B	U	7 pF, 50 V, CERAMIC	70-138181
C434	T	47 uF, 25 V, AL ELECT	70-135168	C725 B	U	15 pF, 50 V, CERAMIC	70-138205
C436	T	47 uF, 25 V, AL ELECT	70-135144	C725 A	U	3 pF, 50 V, CERAMIC	70-138164
C437	T	220 uF, 25 V, AL ELECT	70-135170	C726	U	680 pF, 50 V, CERAMIC	70-138252
C438	U	0.047 uF, 50 V, CERAMIC	70-131298	C726	T	680 pF, 50 V, CERAMIC	70-138252
C423	U	1000 pF, 50 V, CERAMIC	70-138170	C727	T	2200 pF, 25 V, CERAMIC	70-138162
C424	U	10000 pF, 50 V, CERAMIC	70-138168	C728	U	22 pF, 50 V, CERAMIC	70-138171
C438	U	0.047 uF, 50 V, CERAMIC	70-131298				

## TR-1514 RF BOARD (Continued)

REF NO.	LOC	DESCRIPTION	PART NO.	REF NO.	LOC	DESCRIPTION	PART NO.
CAPACITORS (Continued)				RESISTORS (Continued)			
C729	U	22 pF, 50 V, CERAMIC	70-138171	R136	U	47 KOHM, 1/10 W, METAL	70-145145
C730	T	2200 pF, 25 V, CERAMIC	70-138162	R137	U	47 KOHM, 1/10 W, METAL	70-145145
C731	T	680 pF, 50 V, CERAMIC	70-138252	R138	U	47 KOHM, 1/10 W, METAL	70-145145
C732 B	U	2 pF, 50 V, CERAMIC	70-138169	R140	U	220 OHM, 1/10 W, METAL	70-144131
C732 A	U	1 pF, 50 V, CERAMIC	70-138174	R141	U	22 KOHM, 1/10 W, METAL	70-144121
C733 A	U	39 pF, 50 V, CERAMIC	70-138233	R142	U	22 KOHM, 1/10 W, METAL	70-144121
C733 B	U	39 pF, 50 V, CERAMIC	70-138185	R143	U	22 KOHM, 1/10 W, METAL	70-144121
C734 A	U	3 pF, 50 V, CERAMIC	70-138164	R144	U	22 KOHM, 1/10 W, METAL	70-144121
C734 B	U	8 pF, 50 V, CERAMIC	70-138203	R145	U	27 KOHM, 1/10 W, METAL	70-144183
C735 A	U	8 pF, 50 V, CERAMIC	70-138210	R146	U	6.8 KOHM, 1/10 W, METAL	70-144158
C735 B	U	10 pF, 50 V, CERAMIC	70-138187	R147	U	4.7 KOHM, 1/10 W, METAL	70-144123
C736 B	T	680 pF, 50 V, CERAMIC	70-138252	R148	U	10 KOHM, 1/10 W, METAL	70-144120
C736 A	T	100 pF, 50 V, CERAMIC	70-138175	R149	U	18 KOHM, 1/10 W, METAL	70-144185
C737	T	2200 pF, 25 V, CERAMIC	70-138162	R150	U	12 KOHM, 1/10 W, METAL	70-144111
C738	U	1000 pF, 50 V, CERAMIC	70-138170	R151	U	39 KOHM, 1/10 W, METAL	70-144198
C739	U	1000 pF, 50 V, CERAMIC	70-138170	R152	U	82 KOHM, 1/10 W, METAL	70-144173
C741 A	U	1.5 pF, 50 V, CERAMIC	70-138180	R153	U	1 KOHM, 1/10 W, METAL	70-144128
C741 B	U	3 pF, 50 V, CERAMIC	70-138164	R154	U	2.2 KOHM, 1/10 W, METAL	70-144113
C742 B	U	68 pF, 50 V, CERAMIC	70-138229	R156	U	22 KOHM, 1/10 W, METAL	70-144121
C742 A	U	39 pF, 50 V, CERAMIC	70-138233	R157	U	22 KOHM, 1/10 W, METAL	70-144121
C743 B	U	1 pF, 50 V, CERAMIC	70-138174	R158	U	22 KOHM, 1/10 W, METAL	70-144121
C743 A	U	2 pF, 50 V, CERAMIC	70-138169	R159	T	150 KOHM, 1/10 W, METAL	70-144129
C744 A	U	56 pF, 50 V, CERAMIC	70-138254	R159	U	4.7 KOHM, 1/10 W, METAL	70-144123
C744 B	U	39 pF, 50 V, CERAMIC	70-138233	R162	U	270 OHM, 1/10 W, METAL	70-144116
C745	U	3 pF, 50 V, CERAMIC	70-138164	R163	U	18 OHM, 1/10 W, METAL	70-144171
C746	U	10 pF, 50 V, CERAMIC	70-138187	R164	U	270 OHM, 1/10 W, METAL	70-144116
C747	U	1000 pF, 50 V, CERAMIC	70-138170	R166	U	270 OHM, 1/10 W, METAL	70-144116
C751	T	2 pF, 50 V, CERAMIC	70-138175	R167	U	18 OHM, 1/10 W, METAL	70-144171
C752	T	2 pF, 50 V, CERAMIC	70-138175	R168	U	270 OHM, 1/10 W, METAL	70-144116
C753	T	22 pF, 50 V, CERAMIC	70-138171	R169	U	47 KOHM, 1/10 W, METAL	70-145145
C754	T	22 pF, 50 V, CERAMIC	70-138171	R171	U	3.3 KOHM, 1/10 W, METAL	70-144144
C755	T	2200 pF, 25 V, CERAMIC	70-138162	R172	U	68 OHM, 1/10 W, METAL	70-144114
C756	T	2200 pF, 25 V, CERAMIC	70-138162	R173	U	3.3 KOHM, 1/10 W, METAL	70-144144
C757	T	22 pF, 50 V, CERAMIC	70-138171	R174	U	100 OHM, 1/10 W, METAL	70-144146
C761	T	2200 pF, 25 V, CERAMIC	70-138162	R176	U	560 OHM, 1/10 W, METAL	70-144130
C762	T	2200 pF, 25 V, CERAMIC	70-138162	R177	U	10 OHM, 1/10 W, METAL	70-144115
C763	T	1000 pF, 50 V, CERAMIC	70-138170	R178	U	560 OHM, 1/10 W, METAL	70-144130
C764	T	1000 pF, 50 V, CERAMIC	70-138170	R179	U	10 OHM, 1/10 W, METAL	70-144115
C765	T	2200 pF, 25 V, CERAMIC	70-138162	R180	U	22 OHM, 1/10 W, METAL	70-144160
C766	U	1000 pF, 50 V, CERAMIC	70-138170	R181	U	22 OHM, 1/10 W, METAL	70-144160
C767	U	1000 pF, 50 V, CERAMIC	70-138170	R182	U	22 OHM, 1/10 W, METAL	70-144160
C771	U	680 pF, 50 V, CERAMIC	70-138252	R184	U	470 OHM, 1/10 W, METAL	70-144156
C772	U	680 pF, 50 V, CERAMIC	70-138252	R185	U	100 KOHM, 1/10 W, METAL	70-145128
C773	U	680 pF, 50 V, CERAMIC	70-138252	R191	U	220 OHM, 1/10 W, METAL	70-144131
C774	U	680 pF, 50 V, CERAMIC	70-138252	R192	U	3.9 KOHM, 1/10 W, METAL	70-144132
C781	U	22 pF, 50 V, CERAMIC	70-138171	R193	U	6.8 KOHM, 1/10 W, METAL	70-144158
C782	U	22 pF, 50 V, CERAMIC	70-138171	R194	U	1 KOHM, 1/10 W, METAL	70-144128
RESISTORS				R196	U	1 KOHM, 1/10 W, METAL	70-144128
R102	U	88 KOHM, 1/10 W, METAL	70-144119	R197	U	1 KOHM, 1/10 W, METAL	70-144128
R103	U	22 KOHM, 1/10 W, METAL	70-144121	R199	U	12 OHM, 5 W, METAL	70-144197
R104	U	100 KOHM, 1/10 W, METAL	70-145128	R201	U	47 KOHM, 1/10 W, METAL	70-145145
R105	U	47 OHM, 1/10 W, METAL	70-145130	R202	U	47 KOHM, 1/10 W, METAL	70-145145
R106	U	1 MOHM, 1/10 W, METAL	70-144155	R203	U	47 KOHM, 1/10 W, METAL	70-145145
R107	U	47 KOHM, 1/10 W, METAL	70-145145	R204	U	47 KOHM, 1/10 W, METAL	70-145145
R108	U	10 KOHM, 1/10 W, METAL	70-144120	R205	T	8.2 KOHM, 1/10 W, METAL	70-144305
R109	U	47 KOHM, 1/10 W, METAL	70-145145	R215	U	100 OHM, 1/10 W, METAL	70-144146
R110	U	0 OHM, 1/10 W, METAL	70-144106	R216	U	470 OHM, 1/10 W, METAL	70-144156
R111	U	270 OHM, 1/4 W, METAL	70-144193	R217	U	2.2 KOHM, 1/10 W, METAL	70-144113
R112	U	10 KOHM, 1/10 W, METAL	70-144120	R218	U	2.2 KOHM, 1/10 W, METAL	70-144113
R113	U	10 KOHM, 1/10 W, METAL	70-144120	R219	U	150 OHM, 1/10 W, METAL	70-144321
R114	U	33 KOHM, 1/10 W, METAL	70-144112	R220	T	1 KOHM, 1/10 W, METAL	70-144125
R115	U	33 KOHM, 1/10 W, METAL	70-144112	R224	U	22 KOHM, 1/10 W, METAL	70-144121
R116	U	22 KOHM, 1/10 W, METAL	70-144121	R225	U	22 OHM, 1/10 W, METAL	70-144160
R118	U	100 KOHM, 1/10 W, METAL	70-145128	R226	U	47 OHM, 1/10 W, METAL	70-145130
R119	U	1 KOHM, 1/10 W, METAL	70-144128	R231	U	47 OHM, 1/10 W, METAL	70-145130
R120	U	150 KOHM, 1/10 W, METAL	70-144129	R232	U	2.7 KOHM, 1/10 W, METAL	70-144159
R121	U	47 KOHM, 1/10 W, METAL	70-145145	R233	U	1 KOHM, 1/10 W, METAL	70-144128
R122	U	47 KOHM, 1/10 W, METAL	70-145145	R234	U	8.8 KOHM, 1/10 W, METAL	70-144158
R123	U	2.2 KOHM, 1/10 W, METAL	70-144113	R236	U	22 OHM, 1/10 W, METAL	70-144160
R124	U	4.7 KOHM, 1/10 W, METAL	70-144123	R237	U	47 OHM, 1/10 W, METAL	70-145130
R130	U	3.3 KOHM, 1/10 W, METAL	70-144118	R206	U	100 OHM, 1/10 W, METAL	70-144146
R131	U	3.3 KOHM, 1/10 W, METAL	70-144118	R207	U	47 KOHM, 1/10 W, METAL	70-145145
R132	U	470 OHM, 1/10 W, METAL	70-144156	R208	U	47 KOHM, 1/10 W, METAL	70-145145
R133	U	33 OHM, 1/10 W, METAL	70-140320	R209	U	47 KOHM, 1/10 W, METAL	70-145145
R134	U	22 OHM, 1/10 W, METAL	70-144160	R210	T	22 OHM, 1/10 W, METAL	70-144160
R135	U	22 KOHM, 1/10 W, METAL	70-144121	R211	U	47 KOHM, 1/10 W, METAL	70-145145
				R212	U	47 KOHM, 1/10 W, METAL	70-145145

# PARTS

70-3400/3800

## TR-1514 RF BOARD (Continued)

REF NO.	LOC	DESCRIPTION	PART NO.	REF NO.	LOC	DESCRIPTION	PART NO.
RESISTORS (Continued)				RESISTORS (Continued)			
R213	U	47 KOHM, 1/10 W, METAL	70-145145	R422	U	4.7 KOHM, 1/10 W, METAL	70-144123
R214	U	470 OHM, 1/10 W, METAL	70-144156	R423	U	4.7 KOHM, 1/10 W, METAL	70-144123
R238	U	100 OHM, 1/10 W, METAL	70-144146	R424	U	4.7 KOHM, 1/10 W, METAL	70-144123
R239	U	47 OHM, 1/10 W, METAL	70-145130	R425	U	10 KOHM, 1/10 W, METAL	70-144120
R240	U	470 OHM, 1/10 W, METAL	70-145152	R701	T	10 KOHM, 1/10 W, METAL	70-144120
R261	U	220 OHM, 1/10 W, METAL	70-144131	R702	T	6.8 KOHM, 1/10 W, METAL	70-144158
R262	U	3.3 KOHM, 1/10 W, METAL	70-144118	R703	T	22 KOHM, 1/10 W, METAL	70-144121
R263	U	82 KOHM, 1/10 W, METAL	70-144173	R704	T	22 KOHM, 1/10 W, METAL	70-144121
R264	U	18 KOHM, 1/10 W, METAL	70-144195	R705	T	4.7 KOHM, 1/10 W, METAL	70-144123
R265	U	0 OHM, 1/10 W, METAL	70-144106	R705	T	22 KOHM, 1/10 W, METAL	70-144121
R266	U	82 KOHM, 1/10 W, METAL	70-144173	R706	T	150 OHM, 1/10 W, METAL	70-144321
R267	U	47 KOHM, 1/10 W, METAL	70-145145	R707	T	5.6 KOHM, 1/10 W, METAL	70-144168
R268	U	220 KOHM, 1/10 W, METAL	70-144131	R708	T	10 KOHM, 1/10 W, METAL	70-144120
R269	U	1 KOHM, 1/10 W, METAL	70-144128	R711	T	5.6 KOHM, 1/10 W, METAL	70-144168
R271	U	2.7 KOHM, 1/10 W, METAL	70-144159	R712	T	10 KOHM, 1/10 W, METAL	70-144120
R272	U	3.3 KOHM, 1/10 W, METAL	70-144118	R713	T	330 OHM, 1/10 W, METAL	70-144164
R273	U	82 KOHM, 1/10 W, METAL	70-144173	R714	T	150 OHM, 1/10 W, METAL	70-144321
R274	U	10 KOHM, 1/10 W, METAL	70-144120	R721	T	10 KOHM, 1/10 W, METAL	70-144120
R275	U	1.5 KOHM, 1/10 W, METAL	70-144134	R722	T	6.8 KOHM, 1/10 W, METAL	70-144158
R276	U	3.3 KOHM, 1/10 W, METAL	70-144118	R723	T	22 KOHM, 1/10 W, METAL	70-144121
R277	U	1.5 KOHM, 1/10 W, METAL	70-144134	R724	T	22 KOHM, 1/10 W, METAL	70-144121
R278	U	47 KOHM, 1/10 W, METAL	70-145145	R725	T	4.7 KOHM, 1/10 W, METAL	70-144123
R279	U	1 KOHM, 1/10 W, METAL	70-144128	R726	T	150 OHM, 1/10 W, METAL	70-144321
R281	U	47 KOHM, 1/10 W, METAL	70-145145	R727	T	5.6 KOHM, 1/10 W, METAL	70-144168
R282	U	47 KOHM, 1/10 W, METAL	70-145145	R728	T	10 KOHM, 1/10 W, METAL	70-144120
R330	T	330 OHM, 1/10 W, METAL	70-144164	R729	T	330 OHM, 1/10 W, METAL	70-144164
R401	U	10 KOHM, 1/10 W, METAL	70-144120	R731	U	47 KOHM, 1/10 W, METAL	70-145145
R402	U	3.9 KOHM, 1/10 W, METAL	70-144132	R732	T	47 KOHM, 1/10 W, METAL	70-144145
R403	U	2.2 KOHM, 1/10 W, METAL	70-144113	R733	U	47 KOHM, 1/10 W, METAL	70-145145
R404	U	22 OHM, 1/8 W, METAL	70-144074	R741	U	22 KOHM, 1/10 W, METAL	70-144121
R406	T	2.7 KOHM, 1/10 W, METAL	70-144159	R742	U	22 KOHM, 1/10 W, METAL	70-144121
R407	U	2.2 KOHM, 1/10 W, METAL	70-144113	R743	U	22 KOHM, 1/10 W, METAL	70-144121
R408	U	68 KOHM, 1/10 W, METAL	70-144119	R744	U	22 KOHM, 1/10 W, METAL	70-144121
R409	U	22 OHM, 1/8 W, METAL	70-144074			MISCELLANEOUS	
R410	U	47 KOHM, 1/10 W, METAL	70-145145	JP102	U	0 OHM, 1/10 W, METAL	70-144106
R411	U	2.3 OHM, 1/8 W, METAL	70-144198	K401		RELAY AGP9003	70-105022
R414	U	2.3 OHM, 1/8 W, METAL	70-144198	F1		FUSE 5A	70-204062
R418	U	2.3 OHM, 1/8 W, METAL	70-144198				
R420	U	1 KOHM, 1/10 W, METAL	70-144128				

## CX-55 LOGIC BOARD

REF NO.	LOC	DESCRIPTION	PART NO.	REF NO.	LOC	DESCRIPTION	PART NO.
CONNECTORS				DIODES			
J906		34 PIN JACK	70-159422	D901	U	DCB010	70-085245
J909		PROGRAM JACK	70-159428	D902	U	HZM5C-TR	70-085251
J921		11 PIN JACK	70-159429	D903	U	DCB010	70-085245
J922		8 PIN JACK	70-159253	D904	U	LN2G	70-085252
P923		16 PIN PLUG	70-159430	CAPACITORS			
P922		8 PIN PLUG	70-034324	C901	U	1000 pF, 50 V, CERAMIC	70-138170
INTEGRATED CIRCUITS				C902	U	1000 pF, 50 V, CERAMIC	70-138170
IC901	T	HN671106U	70-076470	C903	U	1000 pF, 50 V, CERAMIC	70-138170
IC902	T	HN58C65FP-25	70-076471	C904	U	1000 pF, 50 V, CERAMIC	70-138170
IC903	T	HD63701YOPJ	70-076509	C905	U	1000 pF, 50 V, CERAMIC	70-138170
IC904	T	MB3771FPT	70-076473	C906	U	1000 pF, 50 V, CERAMIC	70-138170
IC905	T	HD/MC14053BFPTR	70-076474	C907	U	1000 pF, 50 V, CERAMIC	70-138170
IC906 A	T	uPC4558G	70-076475	C908	T	1 uF, 50 V, ELECT	70-135172
IC906 B	T	BA228F	70-076569	C909	T	10 uF, 18 V, ELECT	70-135163
IC907	T	MX365P	70-076476	C910	T	10 uF, 18 V, ELECT	70-135163
IC908	T	HD/MC74HC10FPTR	70-076477	C912	T	10 uF, 18 V, ELECT	70-135163
IC909	T	HD/MC14066BFPTR	70-076478	C913	T	1 uF, 50 V, ELECT	70-135172
IC910	T	HD/MC14070BRPTR	70-076479	C915	T	47 uF, 18 V, ELECT	70-135140
IC911	T	HD/MC14516BFPTR	70-076480	C916	U	1000 pF, 50 V, CERAMIC	70-138170
IC912	T	uPC451G2	70-076481	C917	U	47 pF, 50 V, CERAMIC	70-138185
IC913	T	HA17605P	70-076482	C918	U	10000 pF, 50 V, CERAMIC	70-138168
TRANSISTORS				C919	U	18 pF, 50 V, CERAMIC	70-138206
Q901	U	UN4210	70-080304	C920	U	18 pF, 50 V, CERAMIC	70-138206
CONTROLS				C922	U	2200 pF, 50 V, CERAMIC	70-138235
RV901		BRST ADJ 47K	70-164095	C924	U	10000 pF, 50 V, CERAMIC	70-138168
RV901		CTCSS ADJ 47K	70-164095	C925	U	10000 pF, 50 V, CERAMIC	70-138168
				C927	U	33000 pF, 50 V, CERAMIC	70-138257
				C928	U	470 pF, 50 V, CERAMIC	70-138195
				C929	U	33000 pF, 50 V, CERAMIC	70-138257

## CX-55 LOGIC BOARD (Continued)

REF NO.	LOC	DESCRIPTION	PART NO.	REF NO.	LOC	DESCRIPTION	PART NO.
CAPACITORS (Continued)				RESISTORS (Continued)			
C830	U	10000 pF, 50 V, CERAMIC	70-138168	R819	U	22 KOHM, 1/10 W, METAL	70-144121
C831	U	2200 pF, 50 V, CERAMIC	70-138235	R820	U	47 KOHM, 1/10 W, METAL	70-145145
C832	U	10000 pF, 50 V, CERAMIC	70-138168	R821	U	100 KOHM, 1/10 W, METAL	70-145128
C833	U	10000 pF, 50 V, CERAMIC	70-138168	R822	U	22 KOHM, 1/10 W, METAL	70-144121
C834	U	10000 pF, 50 V, CERAMIC	70-138168	R823	U	470 OHM, 1/10 W, METAL	70-144158
C835	U	10000 pF, 50 V, CERAMIC	70-138168	R824	U	470 OHM, 1/10 W, METAL	70-144158
C836	U	10000 pF, 50 V, CERAMIC	70-138168	R825	U	220 KOHM, 1/10 W, METAL	70-144131
C838	U	10000 pF, 50 V, CERAMIC	70-138168	R826	U	100 KOHM, 1/10 W, METAL	70-145128
C839	T	10 uF, 16 V, ELECT	70-135163	R827	U	47 KOHM, 1/10 W, METAL	70-145145
C840	U	10000 pF, 50 V, CERAMIC	70-138168	R829	U	22 KOHM, 1/10 W, METAL	70-144121
C841	U	10000 pF, 50 V, CERAMIC	70-138168	R830	U	22 KOHM, 1/10 W, METAL	70-144121
C842	T	0.47 uF, 35 V, TANT	70-138214	R831	U	4.7 KOHM, 1/10 W, METAL	70-144123
C843	T	47 uF, 16 V, ELECT	70-135140	R832	U	0 OHM, 1/10 W, METAL	70-144108
C844	T	10 uF, 16 V, ELECT	70-135163	R833	U	12 KOHM, 1/10 W, METAL	70-144111
C851	U	220 pF, 50 V, CERAMIC	70-138176	R834	U	100 KOHM, 1/10 W, METAL	70-144120
C852	U	220 pF, 50 V, CERAMIC	70-138176	R835	U	470 KOHM, 1/10 W, METAL	70-144199
C853	U	220 pF, 50 V, CERAMIC	70-138176	R836	U	68 KOHM, 1/10 W, METAL	70-144119
C854	U	220 pF, 50 V, CERAMIC	70-138176	R837	U	4.7 KOHM, 1/10 W, METAL	70-144123
C855	U	220 pF, 50 V, CERAMIC	70-138176	R839	U	220 KOHM, 1/10 W, METAL	70-144131
C856	U	220 pF, 50 V, CERAMIC	70-138176	R840	U	100 KOHM, 1/10 W, METAL	70-145128
C857	U	220 pF, 50 V, CERAMIC	70-138176	R841	U	47 KOHM, 1/10 W, METAL	70-145145
C858	U	220 pF, 50 V, CERAMIC	70-138176	R842	U	100 KOHM, 1/10 W, METAL	70-145128
C859	U	220 pF, 50 V, CERAMIC	70-138176	R843	U	100 KOHM, 1/10 W, METAL	70-145128
C860	U	220 pF, 50 V, CERAMIC	70-138176	R845	U	1 KOHM, 1/10 W, METAL	70-144128
C861	U	220 pF, 50 V, CERAMIC	70-138176	R846	U	150 KOHM, 1/10 W, METAL	70-144129
C862	U	220 pF, 50 V, CERAMIC	70-138176	R847	U	470 KOHM, 1/10 W, METAL	70-144199
C863	U	220 pF, 50 V, CERAMIC	70-138176	R848	U	68 KOHM, 1/10 W, METAL	70-144119
C864	U	220 pF, 50 V, CERAMIC	70-138176	R849	U	150 KOHM, 1/10 W, METAL	70-144129
C865	U	220 pF, 50 V, CERAMIC	70-138176	R851	U	33 KOHM, 1/10 W, METAL	70-144112
C866	U	220 pF, 50 V, CERAMIC	70-138176	R852	U	10 KOHM, 1/10 W, METAL	70-144120
C867	U	220 pF, 50 V, CERAMIC	70-138176	R853	U	33 KOHM, 1/10 W, METAL	70-144112
C868	U	220 pF, 50 V, CERAMIC	70-138176	R854	U	10 KOHM, 1/10 W, METAL	70-144120
C869	U	220 pF, 50 V, CERAMIC	70-138176	R855	U	10 KOHM, 1/10 W, METAL	70-144120
C870	U	220 pF, 50 V, CERAMIC	70-138176	R858	U	470 KOHM, 1/10 W, METAL	70-144199
C871	U	220 pF, 50 V, CERAMIC	70-138176	R857	U	1 KOHM, 1/10 W, METAL	70-144128
C872	U	220 pF, 50 V, CERAMIC	70-138176	R859	U	47 KOHM, 1/10 W, METAL	70-145145
C873	U	4700 pF, 60 V, CERAMIC	70-138204	R860	U	47 KOHM, 1/10 W, METAL	70-145145
C874	U	0.1 uF, 50 V, CERAMIC	70-138236	R862	U	47 KOHM, 1/10 W, METAL	70-145145
C875	U	10000 pF, 50 V, CERAMIC	70-138168	R863	U	0 OHM, 1/10 W, METAL	70-144108
C878	U	0.022 pF, 50 V, PLASTIC	70-137082	R864	U	1 KOHM, 1/10 W, METAL	70-144128
RESISTORS				R865	U	1 KOHM, 1/10 W, METAL	70-144128
R801	U	1 KOHM, 1/10 W, METAL	70-144128	R866	U	1 KOHM, 1/10 W, METAL	70-144128
R802	U	3.3 KOHM, 1/10 W, METAL	70-144144	R867	U	1 KOHM, 1/10 W, METAL	70-144128
R803	U	1 KOHM, 1/10 W, METAL	70-144128	R868	U	1 KOHM, 1/10 W, METAL	70-144128
R804	U	1 KOHM, 1/10 W, METAL	70-144128	R871	U	10 KOHM, 1/10 W, METAL	70-144120
R805	U	1 KOHM, 1/10 W, METAL	70-144128	R872	U	8.2 KOHM, 1/10 W, METAL	70-144305
R806	U	47 KOHM, 1/10 W, METAL	70-145145	R873	U	33 KOHM, 1/10 W, METAL	70-144112
R807	U	4.7 KOHM, 1/10 W, METAL	70-144123	R875	U	100 KOHM, 1/10 W, METAL	70-145128
R808	U	10 KOHM, 1/4 W, CARBON	70-141212	R877	U	220 KOHM, 1/10 W, METAL	70-144131
R809	U	100 KOHM, 1/4 W, CARBON	70-141213	R878	U	100 KOHM, 1/10 W, METAL	70-145128
R810	T	5.6 KOHM, 1/4 W, CARBON	70-141214	R879	U	47 KOHM, 1/10 W, METAL	70-145145
R811	U	5.6 KOHM, 1/4 W, CARBON	70-141214	R880	U	22 KOHM, 1/10 W, METAL	70-144121
R812	U	56 KOHM, 1/10 W, METAL	70-144189	R881	U	22 KOHM, 1/10 W, METAL	70-144121
R816	U	5.6 KOHM, 1/4 W, CARBON	70-141214	R882	U	1 KOHM, 1/10 W, METAL	70-144128
R817	U	4.7 KOHM, 1/10 W, METAL	70-144123	R883	U	1 KOHM, 1/10 W, METAL	70-144128
R818	T	2.2 KOHM, 1/10 W, METAL	70-144107	R884	U	1 KOHM, 1/10 W, METAL	70-144128
R819	T	47 MOHM, 1/10 W, METAL	70-144182	R885	U	1 KOHM, 1/10 W, METAL	70-144128
R901	U	47 KOHM, 1/10 W, METAL	70-145145	R886	U	1 KOHM, 1/10 W, METAL	70-144128
R902	U	47 KOHM, 1/10 W, METAL	70-145145	R887	U	1 KOHM, 1/10 W, METAL	70-144128
R903	U	47 KOHM, 1/10 W, METAL	70-145145	R888	U	1 KOHM, 1/10 W, METAL	70-144128
R904	U	47 KOHM, 1/10 W, METAL	70-145145	R889	U	1 KOHM, 1/10 W, METAL	70-144128
R905	U	47 KOHM, 1/10 W, METAL	70-145145	R890	U	1 KOHM, 1/10 W, METAL	70-144128
R906	U	47 KOHM, 1/10 W, METAL	70-145145	R892	U	1 KOHM, 1/10 W, METAL	70-144128
R907	U	47 KOHM, 1/10 W, METAL	70-145145	R894	U	1 KOHM, 1/10 W, METAL	70-144128
R908	U	47 KOHM, 1/10 W, METAL	70-145145	R895	U	1 KOHM, 1/10 W, METAL	70-144128
R909	U	1 KOHM, 1/10 W, METAL	70-144128	R896	U	1 KOHM, 1/10 W, METAL	70-144128
R910	U	1 KOHM, 1/10 W, METAL	70-144128	R897	U	1 KOHM, 1/10 W, METAL	70-144128
R911	U	1 KOHM, 1/10 W, METAL	70-144128	R898	U	1 KOHM, 1/10 W, METAL	70-144128
R912	U	1 KOHM, 1/10 W, METAL	70-144128	R899	U	1 KOHM, 1/10 W, METAL	70-144128
R913	U	1 KOHM, 1/10 W, METAL	70-144128	MISCELLANEOUS			
R914	U	1 KOHM, 1/10 W, METAL	70-144128	JP801	U	0 OHM, 1/10 W, METAL	70-144108
R915	U	1 KOHM, 1/10 W, METAL	70-144128	JP802	U	0 OHM, 1/10 W, METAL	70-144108
R916	U	1 KOHM, 1/10 W, METAL	70-144128	X801	T	CRYSTAL	70-128078
R917	U	100 KOHM, 1/10 W, METAL	70-145128	Z323	T	SUB-PC BOARD	70-070302
R918	U	10 KOHM, 1/10 W, METAL	70-144120				

# PARTS

70-3400/3800

## PA-1553 40 WATT PA MODULE

REF NO.	LOC	DESCRIPTION	PART NO.	REF NO.	LOC	DESCRIPTION	PART NO.
CONNECTORS				CAPACITORS			
J501		INPUT JACK	70-159089	C517	U	82 pF, 50 V, CERAMIC	70-138260
J502		ANTENNA JACK	70-159427	C518 A	U	220 pF, 100 V, CERAMIC	70-138261
J503		RECEIVE JACK	70-159089	C518 B	U	150 pF, 100 V, CERAMIC	70-138258
P505		ACCESSORY PLUG	70-034322	C519	T	220 pF, 100 V, CERAMIC	70-138261
CABLES				C520	T	220 pF, 100 V, CERAMIC	70-138261
CA501		TX COAX	70-034325	C521 B	T	220 pF, 100 V, MICA	70-138112
CA502		J508 ASSEMBLY	70-034318	C522	U	1000 pF, 100 V, CERAMIC	70-138239
CA503		RX COAX	70-034325	C523 A	U	220 pF, 100 V, MICA	70-138112
CA504		P104 ASSEMBLY	70-034320	C523 B	U	100 pF, 100 V, MICA	70-138115
CA505		J505 ASSEMBLY	70-034321	C524 A	U	120 pF, 100 V, MICA	70-138109
TRANSISTORS				C524 B	U	82 pF, 100 V, MICA	70-138250
Q501	T	2SC1971	70-080305	C525 B	U	91 pF, 100 V, MICA	70-138110
Q502	T	2SC2539	70-080090	C525 A	U	120 pF, 100 V, MICA	70-138116
Q503	T	2SC2694	70-080133	C527 A	U	33 pF, 500 V, CERAMIC	70-138262
Q504	T	2SC26945	70-080338	C527 B	U	22 pF, 500 V, CERAMIC	70-138263
Q505	T	2SC26945	70-080338	C528 A	U	220 pF, 500 V, CERAMIC	70-138261
Q506	U	2SC2462LC	70-080160	C528 B	U	100 pF, 500 V, CERAMIC	70-138264
Q507	U	2SC2462LC	70-080160	C529	U	1000 pF, 50 V, CERAMIC	70-138170
COILS				C530	U	1000 pF, 50 V, CERAMIC	70-138170
L501	T	Z0.8C5D 0.5T	70-090325	C531	U	220 pF, 100 V, CERAMIC	70-138261
L502	T	BL02RN1-R62	70-090122	C532 B	U	12 pF, 500 V, CERAMIC	70-138266
L504	T	Z0.8C5D 2.5T	70-090098	C532 A	U	18 pF, 500 V, CERAMIC	70-138265
L505	T	BL02RN1-R62	70-090122	C533	U	12 pF, 50 V, CERAMIC	70-138209
L506	T	Z0.8C5D 0.5T	70-090160	C535	T	0.22 uF, 50 V, PLASTIC	70-138160
L510	T	42L004	70-090127	C536	U	1000 pF, 50 V, CERAMIC	70-138170
L511	T	Z1.2C5D 2.5T	70-090102	C537 A	U	39 pF, 50 V, CERAMIC	70-138233
L512	T	Z1.2C5D 2.5T	70-090102	C537 B	U	33 pF, 50 V, CERAMIC	70-138188
L513	T	Z1.2C5D 2.5T	70-090102	C538	U	1000 pF, 50 V, CERAMIC	70-138170
L514	T	Z1.2C5D 2.5T	70-090102	C539	U	1000 pF, 50 V, CERAMIC	70-138170
L515	T	Z0.8C5D 2.5T	70-090098	C544	U	0.01 uF, 50 V, CERAMIC	70-138168
L517	T	Z0.8C5D 2.5T	70-090098	C545 B	U	15 pF, 500 V, CERAMIC	70-138267
DIODES				C545 A	U	22 pF, 500 V, CERAMIC	70-138263
D501	T	UM9401	70-085056	C546 B	U	33 pF, 500 V, CERAMIC	70-138262
D502	T	MI407	70-085047	C546 A	U	47 pF, 500 V, CERAMIC	70-138268
D503	U	HSM885	70-085154	C547 A	U	47 pF, 500 V, CERAMIC	70-138268
D505	U	DCA010	70-085250	C547 B	U	33 pF, 500 V, CERAMIC	70-138262
D506	T	RM4AM	70-085157	C548	U	33 pF, 500 V, CERAMIC	70-138262
TRIMMER CAPACITORS				C549	U	15 pF, 500 V, CERAMIC	70-138267
CV501	T	40 pF	70-123024	C552	U	0.1 uF, 50 V, CERAMIC	70-138249
CV504	T	40 pF	70-123024	C552	U	1000 pF, 50 V, CERAMIC	70-138170
CONTROLS				C554	T	15 uF, 25 V, ELECT	70-135154
RV502	T	HI PWR ADJUSTMENT	70-164096	C555	U	1000 pF, 50 V, CERAMIC	70-138170
CAPACITORS				C557	U	1000 pF, 50 V, CERAMIC	70-138170
C501	U	1000 pF, 50 V, CERAMIC	70-138170	C560 B	T	1000 pF, 50 V, CERAMIC	70-132042
C502 A	U	47 pF, 50 V, CERAMIC	70-138185	C801	U	1000 pF, 50 V, CERAMIC	70-138170
C502 B	U	22 pF, 50 V, CERAMIC	70-138171	C802	U	0.01 uF, 50 V, CERAMIC	70-138168
C503	U	1000 pF, 50 V, CERAMIC	70-138170	C803	U	0.047 uF, 50 V, CERAMIC	70-138256
C504	T	10 uF, 50 V, ELECT	70-135174	C804	U	1000 pF, 50 V, CERAMIC	70-138170
C505 B	T	22 pF, 50 V, CERAMIC	70-138171	C805	U	0.01 uF, 50 V, CERAMIC	70-138168
C505 A	T	47 pF, 50 V, CERAMIC	70-138185	C806	U	0.047 uF, 50 V, CERAMIC	70-138256
C506	U	0.01 uF, 50 V, CERAMIC	70-138168	RESISTORS			
C507	T	47 pF, 50 V, CERAMIC	70-138185	R501	U	820 OHM, 1/10 W, METAL	70-144165
C508	T	0.1 uF, 50 V, PLASTIC	70-137084	R502	U	150 OHM, 1/10 W, METAL	70-140321
C509	U	47 pF, 50 V, CERAMIC	70-138185	R504	U	22 OHM, 1/8 W, METAL	70-144074
C510	U	58 pF, 50 V, CERAMIC	70-138254	R505	U	22 OHM, 1/8 W, METAL	70-144074
C511	U	47 pF, 50 V, CERAMIC	70-138185	R509	T	2.2 OHM, 1/8 W, METAL	70-144200
C513 B	U	1000 pF, 100 V, CERAMIC	70-138239	R511 A	U	39 OHM, 1/10 W, METAL	70-144125
C513 A	U	150 pF, 50 V, CERAMIC	70-138258	R511 B	U	47 OHM, 1/10 W, METAL	70-145130
C514	U	1000 pF, 100 V, CERAMIC	70-138239	R512	U	47 KOHM, 1/10 W, METAL	70-145145
C515	U	68 pF, 50 V, CERAMIC	70-138229	R513	U	47 KOHM, 1/10 W, METAL	70-145145
C516	U	82 pF, 500 V, CERAMIC	70-138259	R515	U	470 OHM, 1/10 W, METAL	70-144015
				R516	U	470 OHM, 1/10 W, METAL	70-144015
				R519	U	120 OHM, 1/8 W, METAL	70-144010
				R524	U	100 OHM, 1/10 W, METAL	70-144009
				R525 A	U	2.2 KOHM, 1/10 W, METAL	70-144229
				R525 B	U	1.8 KOHM, 1/10 W, METAL	70-144154
				R526	U	47 OHM, 1/10 W, METAL	70-145130
				R527	U	330 OHM, 1/10 W, METAL	70-144164
				R528	U	47 OHM, 1/10 W, METAL	70-145130
				R529	U	4.7 KOHM, 1/10 W, METAL	70-144199
				R530	U	0 OHM, 1/10 W, METAL	70-144106
				R531	T	33 OHM, 1 W, METAL	70-144201



## PA-1554 110 WATT PA MODULE

REF NO.	LOC	DESCRIPTION	PART NO.	REF NO.	LOC	DESCRIPTION	PART NO.
CONNECTORS				CAPACITORS (Continued)			
J501		INPUT JACK	70-159089	C518 B	U	47 pF, 50 V, CERAMIC	70-138185
J502		ANTENNA JACK	70-159427	C517 A	U	68 pF, 50 V, CERAMIC	70-138229
J503		RECEIVE JACK	70-159089	C517 B	U	47 pF, 50 V, CERAMIC	70-138185
P505		ACCESSORY PLUG	70-034333	C518	U	470 pF, 50 V, CERAMIC	70-138238
CABLES				C519 A	U	1000 pF, 50 V, CERAMIC	70-138170
CA501		TX COAX	70-034198	C520	U	68 pF, 50 V, CERAMIC	70-138229
CA502		J501 ASSEMBLY	70-034332	C521 B	T	15 uF, 25 V, ELECT	70-135154
CA503		RX COAX	70-034198	C521 A	T	100 uF, 25 V, ELECT	70-135050
CA504		P104 ASSEMBLY	70-034320	C522	U	100 pF, 50 V, CERAMIC	70-138175
CA505		J505 ASSEMBLY	70-034321	C523	T	1000 pF, 50 V, CERAMIC	70-132042
TRANSISTORS				C524	T	220 pF, 100 V, MICA	70-138112
Q501	T	2SC2538	70-080108	C525	T	220 pF, 100 V, MICA	70-138112
Q502	T	2SC2539	70-080090	C526	T	33 pF, 500 V, MICA	70-138098
Q503	T	2SC2630	70-080091	C527 B	T	33 pF, 500 V, MICA	70-138098
Q504	T	2SC2694	70-080133	C527 A	T	47 pF, 500 V, MICA	70-138109
Q506	T	2SB945Q	70-080214	C528	T	1000 pF, 50 V, CERAMIC	70-132042
Q508	U	2SC2462	70-080160	C529	T	220 uF, 25 V, ELECT	70-131030
Q509	U	2SC2462	70-080160	C531	U	0.047 uF, 50 V, CERAMIC	70-138258
Q510	U	2SC2462	70-080160	C532 A	U	1000 pF, 50 V, CERAMIC	70-138170
DIODES				C532 B	U	0.1 uF, 50 V, CERAMIC	70-138249
D502	U	HSM88S	70-085154	C533	U	0.047 uF, 50 V, CERAMIC	70-138258
D505 B	U	DCA010	70-085250	C534	U	1000 pF, 50 V, CERAMIC	70-131222
COILS				C535	T	0.1 uF, 50 V, PLASTIC	70-138189
L501	T	Z0.8C5D 1.5T	70-090097	C538 B	U	62 pF, 500 V, MICA	70-138121
L504	T	Z0.8C5D 1.5T	70-090097	C537 B	U	47 pF, 500 V, MICA	70-138114
L508	T	Z0.8C5D 1.5T	70-090097	C538 A	T	82 pF, 500 V, MICA	70-138109
L505 A	T	Z0.8C5D 0.5T	70-090160	C538 B	T	56 pF, 500 V, MICA	70-138117
L505 B	T	Z0.8C5D 1.5T	70-090097	C539	T	62 pF, 500 V, MICA	70-138121
L506 A	T	Z0.8C5D 0.5T	70-090160	C540 A	U	39 pF, 100 V, MICA	70-138112
L506 B	T	Z0.8C5D 2.5T	70-090098	C541 B	U	62 pF, 500 V, MICA	70-138121
L511	T	Z0.8C5D 8.5T	70-090131	C541 A	U	47 pF, 100 V, MICA	70-138114
L514	T	Z0.8C5D 8.5T	70-090131	C542 A	U	82 pF, 100 V, MICA	70-138109
L512	T	Z1.2C5D 1.5T	70-090133	C542 B	U	100 pF, 100 V, MICA	70-138115
L513	T	Z1.2C5D 1.5T	70-090133	C543 A	U	47 pF, 50 V, CERAMIC	70-138283
L515	T	Z1.2C5D 2.5T	70-090102	C546	T	10 uF, 50 V, ELECT	70-135059
L516	T	Z1.2C5D 2.5T	70-090102	C547	U	1000 pF, 50 V, CERAMIC	70-131222
L517	T	Z1.2C5D 2.5T	70-090102	C548	U	1000 pF, 50 V, CERAMIC	70-131222
L518	T	Z1.2C5D 2.5T	70-090102	C551 A	U	100 pF, 100 V, MICA	70-138115
CONTROLS				C551 B	U	62 pF, 500 V, MICA	70-138121
RV501	T	POWER ADJUSTMENT	70-184040	C552 B	U	27 pF, 500 V, MICA	70-138097
VARIABLE CAPACITORS				C552 A	U	62 pF, 500 V, MICA	70-138121
CV503	T	40 uF	70-123024	C554	U	220 pF, 100 V, MICA	70-138073
CV504	T	40 uF	70-123024	C555	U	220 pF, 100 V, MICA	70-138073
CV505	T	222-809-08003	70-123031	C556	U	220 pF, 100 V, MICA	70-138112
CAPACITORS				C557	U	220 pF, 100 V, MICA	70-138112
C501 B	U	39 pF, 50 V, CERAMIC	70-138233	C558 A	T	12 pF, 500 V, MICA	70-138094
C502	U	15 pF, 50 V, CERAMIC	70-138205	C558 B	T	33 pF, 500 V, MICA	70-138083
C503	U	1000 pF, 50 V, CERAMIC	70-138255	C561 A	T	12 pF, 500 V, MICA	70-138094
C504	U	1000 pF, 50 V, CERAMIC	70-138255	C561 B	T	33 pF, 500 V, MICA	70-138083
C505	T	15 uF, 25 V, ELECT	70-135154	C562 A	U	0.047 uF, 50 V, CERAMIC	70-138258
C506 B	U	82 pF, 50 V, CERAMIC	70-138250	C562 B	U	4700 PF, 50 V, CERAMIC	70-132034
C506 A	U	100 pF, 50 V, CERAMIC	70-138175	C563	U	1000 pF, 50 V, CERAMIC	70-131222
C507 A	U	33 pF, 50 V, CERAMIC	70-138188	C564	U	1000 pF, 50 V, CERAMIC	70-138073
C507 B	U	12 pF, 50 V, CERAMIC	70-138209	C565 A	U	0.047 uF, 50 V, CERAMIC	70-138258
C508 A	U	33 pF, 50 V, CERAMIC	70-138188	C565 B	U	4700 PF, 50 V, CERAMIC	70-132034
C508 B	U	18 pF, 50 V, CERAMIC	70-138208	C566	U	1000 pF, 50 V, CERAMIC	70-131222
C510	U	1000 pF, 50 V, CERAMIC	70-138255	C567	U	1000 pF, 50 V, CERAMIC	70-138073
C511	U	100 pF, 50 V, CERAMIC	70-138175	C568	U	1000 pF, 50 V, CERAMIC	70-138170
C512 B	U	100 pF, 50 V, CERAMIC	70-138175	C569 A	U	22 pF, 100 V, MICA	70-138107
C513	U	33 pF, 50 V, CERAMIC	70-138188	C570 A	U	22 pF, 100 V, MICA	70-138107
C514	U	47 pF, 50 V, CERAMIC	70-138185	C571	T	47 uF, 25 V, ELECT	70-135055
C515 A	U	5 pF, 50 V, CERAMIC	70-138205	C574	U	91 pF, 500 V, MICA	70-138110
C515 B	U	1000 pF, 50 V, CERAMIC	70-132042	C575	U	91 pF, 500 V, MICA	70-138110
C518 A	U	68 pF, 50 V, CERAMIC	70-138229	C575	U	22 pF, 100 V, MICA	70-138107
				C576 B	U	56 pF, 500 V, MICA	70-138117
				C576 A	U	100 pF, 500 V, MICA	70-138115
				C577	U	1000 pF, 50 V, CERAMIC	70-131222
				C578	U	1000 pF, 50 V, CERAMIC	70-131222
				C579 B	U	91 pF, 500 V, MICA	70-138110
				C579 A	U	100 pF, 100 V, MICA	70-138115
				C580 A	U	100 pF, 100 V, MICA	70-138115
				C580 B	U	91 pF, 500 V, MICA	70-138110
				C581	T	56 pF, 500 V, MICA	70-138117
				C581	U	33 pF, 500 V, MICA	70-138083
				C583	U	47 pF, 500 V, MICA	70-138114
				C584 A	U	22 pF, 500 V, MICA	70-138084
				C584 B	U	27 pF, 500 V, MICA	70-138083
				C585 B	U	33 pF, 500 V, MICA	70-138083

# PARTS

70-3400/3800

## PA-1554 110 WATT PA MODULE (Continued)

REF NO.	LOC	DESCRIPTION	PART NO.	REF NO.	LOC	DESCRIPTION	PART NO.
CAPACITORS (Continued)				RESISTORS			
C585 A	U	58 pF, 500 V, MICA	70-138107	R501	U	150 OHM, 1/10 W, METAL	70-140321
C586 A	U	58 pF, 500 V, MICA	70-138107	R502	U	2.2 KOHM, 1/10 W, METAL	70-144113
C586 B	U	33 pF, 500 V, MICA	70-138083	R503	R	180 OHM, 1/10 W, METAL	70-144221
C588	U	15 pF, 500 V, MICA	70-138080	R504	U	1 KOHM, 1/10 W, METAL	70-144125
C590 B	U	3 pF, 500 V, MICA	70-138126	R505 A	U	COIL BLOZRN1-R82	70-090326
C591	U	7 pF, 50 V, CERAMIC	70-138181	R505 B	U	3.3 OHM, 1 W, METAL	70-142028
C592	U	1000 pF, 50 V, CERAMIC	70-138170	R506	U	3.3 OHM, 1 W, METAL	70-144048
C593 B	U	18 pF, 50 V, CERAMIC	70-138206	R508	U	3.3 OHM, 1 W, METAL	70-144048
C593 A	U	27 pF, 50 V, CERAMIC	70-138165	R509	U	3.3 OHM, 1 W, METAL	70-144048
CONNECTORS				R507	U	3.3 OHM, 2 W, METAL	70-145143
C594	U	1000 pF, 50 V, CERAMIC	70-138170	R510 B	U	10 OHM, 2 W, METAL	70-144082
C595	U	1000 pF, 50 V, CERAMIC	70-138170	R512	U	470 OHM, 1/10 W, METAL	70-144156
C596	U	1000 pF, 50 V, CERAMIC	70-138170	R513	U	1.8 KOHM, 1/10 W, METAL	70-144154
C597	U	1000 pF, 50 V, CERAMIC	70-138170	R514	U	47 OHM, 1/10 W, METAL	70-145130
C598	U	1000 pF, 50 V, CERAMIC	70-138170	R515	U	47 OHM, 1/10 W, METAL	70-145130
C599	U	1000 pF, 50 V, CERAMIC	70-138170	R516	U	330 OHM, 1/10 W, METAL	70-144164
C600 A	T	4.7 uF, 16 V, ELECT	70-138172	R517 A	U	2.2 KOHM, 1/10 W, METAL	70-144113
C601 A	U	1000 pF, 50 V, CERAMIC	70-138170	R517 B	U	2.7 KOHM, 1/10 W, METAL	70-144159
C801	U	1000 pF, 50 V, CERAMIC	70-138170	R518 A	U	150 OHM, 1/10 W, METAL	70-140321
C802	U	0.01 uF, 50 V, CERAMIC	70-138168	R518 B	U	100 OHM, 1/10 W, METAL	70-145131
C803	U	0.047 uF, 50 V, CERAMIC	70-138256	R519 B	U	10 OHM, 2 W, METAL	70-145131
C804	U	1000 pF, 50 V, CERAMIC	70-138170	R521	U	100 KOHM, 1/10 W, METAL	70-145128
C805	U	0.01 uF, 50 V, CERAMIC	70-138168	R522	U	100 KOHM, 1/10 W, METAL	70-145128
C806	U	0.047 uF, 50 V, CERAMIC	70-138256	R523	U	300 OHM, 1/10 W, METAL	70-144164
FERRITE BEADS				R525 A	U	2.2 OHM, 2 W, METAL	70-145050
FB501 B	U	FERRITE BEAD	70-178088	R525 B	U	4.7 OHM, 5 W, METAL	70-144197
FB502	U	FERRITE BEAD	70-178089	R526	U	2.2 KOHM, 1/10 W, METAL	70-144202
FB503	U	FERRITE BEAD	70-178089	R527 B	U	58 OHM, 1/10 W, METAL	70-141217
FB505	U	FERRITE BEAD	70-178089	R530 A	U	33 OHM, 1 W, METAL	70-142028
FB506	U	FERRITE BEAD	70-178089	R531	U	0 OHM, 1/10 W, METAL	70-144106
FB504	U	FERRITE BEAD	70-178088	R537 A	U	0 OHM, 1/10 W, METAL	70-144106
FB507 A	U	FERRITE BEAD	70-178089	R538 B	T	22 OHM, 1/10 W, METAL	70-144074
				R538 A	U	47 OHM, 1/10 W, METAL	70-144006
				R538 B	T	22 OHM, 1/10 W, METAL	70-144074
				R539	T	22 OHM, 1/10 W, METAL	70-144074

## Z-502 NOSE PIECE CONNECTOR BOARD

REF NO.	DESCRIPTION	PART NO.
CONNECTORS		
P152	30 PIN PLUG	70-159431
J153	CONTROL CABLE JACK	70-159432
RESISTORS		
R430	33 OHM, 1 W	70-142028

**70-2326 MICROPHONE**

DESCRIPTION	PART NO.
LMR DYNAMIC MIC	70-038013
ELEMENT, DYNAMIC	70-038004
P/T SWITCH	70-183004
PCB W/ COMP	70-075014
PCB W/O COMP	70-070008
2SA1015	70-080025
2SC536	70-080028
ELECT CAP, 10 uF, 50 WV	70-135002
CERAMIC CAP (102)	70-132005
RESISTOR 270 OHM, 1/4 W	70-141010
RESISTOR, 470 OHM, 1/4 W	70-141016
RESISTOR, 180 KOHM, 1/4 W	70-141037
PLUG MIC 6 PIN	70-159184

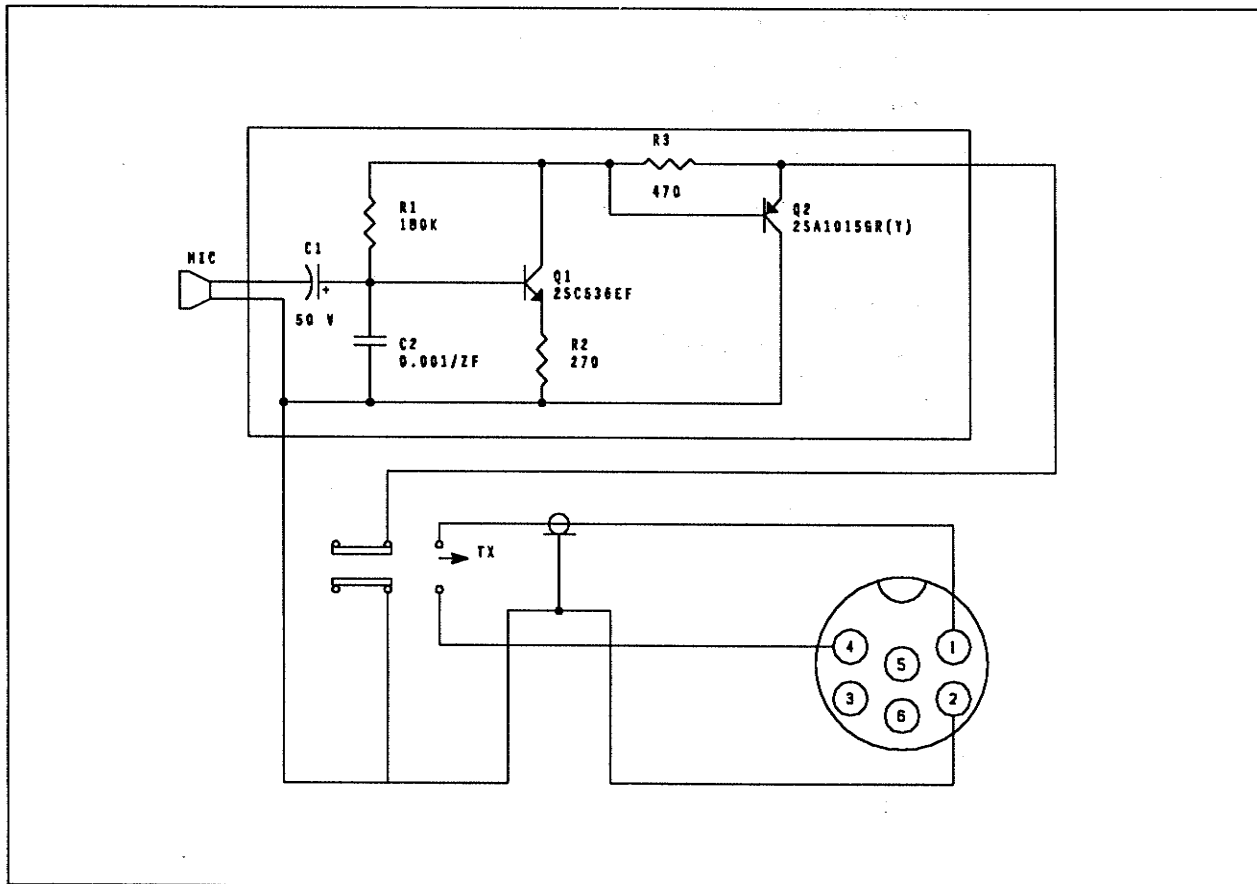

**6**

**REPLACEMENT PARTS ORDERING**

To speed delivery and avoid errors, always include the following information when ordering replacement parts:

1. Best identification of the parts.
  - A. MIDLAND part number, or
  - B. Model and Serial numbers of equipment in which the part is used, with
  - C. Part description, and
  - D. Schematic reference designator, and,
  - E. If necessary, return the old part as sample.
2. Specify quantity desired of each part.
3. Ship-to address (and billing address if different).

Mail or phone your order to:

MIDLAND INTERNATIONAL CORPORATION  
1690 North Topping Avenue  
Kansas City, Missouri 64120  
(816) 241-8500

1

2

3

4



THE UNIVERSITY OF CHICAGO  
DIVISION OF THE PHYSICAL SCIENCES  
DEPARTMENT OF CHEMISTRY  
5708 S. UNIVERSITY AVENUE  
CHICAGO, ILLINOIS 60637  
TEL: 773-936-3700  
FAX: 773-936-3701  
WWW: WWW.CHEM.UCHICAGO.EDU

10/10/00

# **MIDLAND**

## **RADIO CORPORATION**

**5900 Parretta Drive**

**Kansas City, MO 64120**

**Tele: 816-241-8500**

**Fax: 816-241-5713**

**[www.midlandradio.com](http://www.midlandradio.com)**

**Email: [mail@midlandradio.com](mailto:mail@midlandradio.com)**

**(Info correct as of 2/10/2006)**