

K13

# MIDLAND LMR

LAND MOBILE RADIO

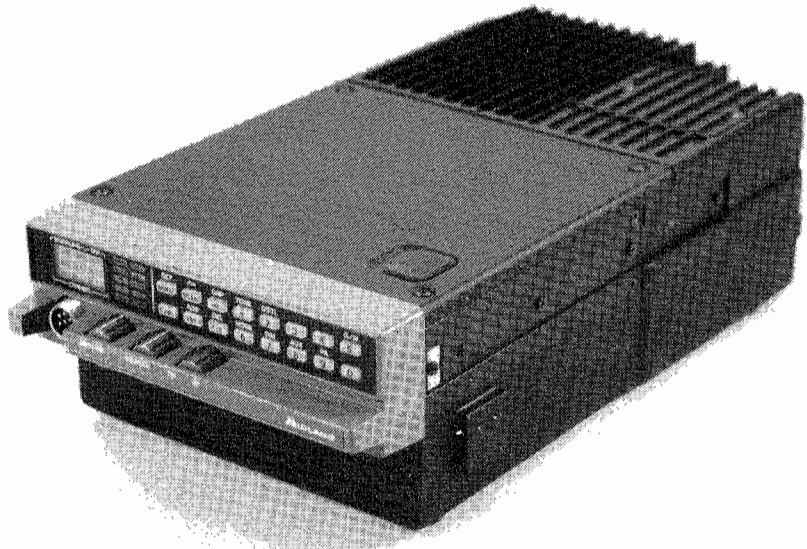

70-5400B

## SERVICE MANUAL

### 70-3400AD/BD

### 70-5300AD/BD

### SYN-TECH II DUPLEX

### MOBILE/BASE STATION/ REPEATER

### VHF HIGH BAND

(136 — 160 MHz, 150 — 174 MHz)

### 40 WATT

### UHF BAND

(406 — 430 MHz, 450 — 470 MHz)

### 30 WATT

MANUAL NO.: 70-340530  
09-3400/5300-SM-1/93

SYN-TECH II service information is published in three parts.

**Part One** contains general servicing and installation information that is common to the entire SYN-TECH II line.

**Part Two** contains technical data and drawings for the SYN-TECH II Control Heads. Two versions of this part exist: one for the the Deluxe Control head, and one for the Standard and Small-Remote Control Heads.

**Part Three** contains technical data and drawings for SYN-TECH II TX/RX Units.

This service manual is Part Three, and contains specific technical data and drawings for the 70-3400AD/BD and 70-5300AD/BD SYN-TECH II TX/RX Units.

This manual section is designed to facilitate the set-up and service of the Syn-Tech II Duplexer transceivers. As necessary, service manual supplements will be published and distributed on the following forms:

- Manual Addition (MA) . . . . . For supplemental information useful in product service or improvement. Printed on BLUE paper.
- Change Notice (CN) . . . . . For details about changes made during production by model and serial number. Printed on YELLOW paper.
- Manual Correction (MC) . . . . . For correcting literature errors not related to production changes. Printed on GREEN paper.
- Technical Bulletin (TB) . . . . . For solutions to field problems and tips for performance improvement. Printed on PINK paper.

Comments or suggestions concerning areas of manual improvement are welcome.

**IMPORTANT NOTE**

The 70-3400AD/BD and 70-5300AD/BD are based on the 70-3400 and 70-5300, respectively. A Transmit Exciter Board has been added, some changes to the wiring have been made, the PA casting has been enlarged, and a duplexer housing has been added. For this reason, only information relating to these modifications has been covered in this manual. All other information for VHF units (70-3400AD/BD) can be found in the 70-3400A/B service manual (manual number 70-340380). For UHF units (70-5300AD/BD), refer to 70-5300A/B service manual (manual number 70-530000).

# TABLE OF CONTENTS

	<b>Manual Supplement Information</b> .....	ii
	<b>Table of Contents</b> .....	iii
	<b>Acronyms and Abbreviations</b> .....	vi
<b>SECTION 1</b>	<b>GENERAL INFORMATION</b>	
	Description .....	1 - 3
	Specifications .....	1 - 3
	Accessories .....	1 - 5
<b>SECTION 2</b>	<b>PREPARATION</b>	
	Alignment Requirements .....	2 - 3
	70-3400AD/BD Alignment .....	2 - 4
	70-5300AD/BD Alignment .....	2 - 5
<b>SECTION 3</b>	<b>SERVICING</b>	
	Accessing Duplexer Housing .....	3 - 3
	Troubleshooting Charts .....	3 - 5
<b>SECTION 4</b>	<b>CIRCUIT DESCRIPTIONS</b>	
	70-3400AD/BD Circuit Description .....	4 - 3
	70-5300AD/BD Circuit Description .....	4 - 5
	Logic Board — Serial-Data Peripherals .....	4 - 7
	Transmit Audio Routing .....	4 - 8
<b>SECTION 5</b>	<b>DIAGRAMS</b>	
	Duplexer Wiring Diagram .....	5 - 3
	70-0001 Wiring Diagram—Under-Dash .....	5 - 3
	70-0001 Wiring Diagram—Trunk-Mount .....	5 - 3
	70-0002 Wiring Diagram—Under-Dash .....	5 - 4
	70-0002 Wiring Diagram—Trunk-Mount .....	5 - 4
	70-0007 Wiring Diagram—Trunk-Mount .....	5 - 4
	70-7010 Interface Connections .....	5 - 5
	70-3400AD/BD Block Diagram .....	5 - 6
	70-5300AD/BD Block Diagram .....	5 - 7
	70-3400AD/BD Board Layout .....	5 - 8
	70-3400AD/BD TX Exciter Schematic .....	5 - 9
	70-5300AD/BD Board Layout .....	5 - 10
	70-5300AD/BD TX Exciter Schematic .....	5 - 11
	70-3400AD/BD Exploded View .....	5 - 12
	70-5300AD/BD Exploded View .....	5 - 13
<b>SECTION 6</b>	<b>PARTS</b>	
	Parts List .....	6 - 3
	Replacement Parts Ordering .....	6 - 8

**SECTION 1—General Information** **1**

**SECTION 2—Preparation** **2**

**SECTION 3—Servicing** **3**

**SECTION 4—Circuit Descriptions** **4**

**SECTION 5—Diagrams** **5**

**SECTION 6—Parts** **6**

## ACRONYMS AND ABBREVIATIONS

Below is a list of common electrical acronyms and abbreviations used in this manual.

ANI .....	Automatic Number Identification
CTCSS .....	Continuous Tone-Controlled Squelch System
DCS (or CDCSS) .....	Continuous Digital-Controlled Squelch System
DTMF .....	Dual Tone Multi-Frequency
E <sup>2</sup> PROM .....	Electrically Erasable Programmable Read Only Memory
MIL .....	Military Specification
RX .....	Receive
SINAD .....	The ratio in decibels of signal + noise + distortion to noise + distortion
TX .....	Transmit
VCO .....	Voltage Controlled Oscillator

**SECTION 1**

---

**GENERAL INFORMATION**

# GENERAL INFORMATION

---

70-3400AD/BD—70-5300AD/BD

## NOTES

**DESCRIPTION**

The SYN-TECH II Duplex product series is based on the standard SYN-TECH II Radio. The duplex unit incorporates the use of two synthesizer boards instead of one. One operates as the transmit synthesizer/exciter and the other as the receiver local oscillator synthesizer. This enables the unit to receive and transmit simultaneously in duplex or repeater operation.

**1****SPECIFICATIONS**

Refer to EIA 152C, EIA/TIA 204-D and DOC RSS-119 Issue 4 for standard of performance and method of measurement.

**GENERAL****FREQUENCY RANGE:**

VHF A-Band: 136—160 MHz  
VHF B-Band: 150—174 MHz  
UHF A-Band: 406—430 MHz  
UHF B-Band: 450—470 MHz

**MODEL NUMBER:**

VHF A-Band: 70-3400AD  
VHF B-Band: 70-3400BD  
UHF A-Band: 70-5300AD  
UHF B-Band: 70-5300BD

**PRIMARY POWER:** 13.6 V DC

**CURRENT DRAIN:**

Transmit (full power): 8.0 A  
Receive (at full rated audio): 2.0 A  
Standby (varies with options): 0.6 A typical

**CHANNEL CAPACITY:** Programmable for up to 320 TX and RX channels in up to 16 groups

**DIMENSIONS (H x W x D):**

Basic TX/RX Units: 103 x 190 x 330 mm (4.12 x 7.60 x 13.20 in) **NOTE:** Control units (dash-mount configuration) adds 40 mm (1.57 in) depth. Trunk-mount front cap adds 60 mm (2.36 in) depth.

Control units configured as trunk-mount control heads: 57 x 185 x 75 mm (2.25 x 7.28 x 2.95 in)

Small Remote Control Head: 57 x 120 75 mm (2.25 x 4.72 x 2.95 in)

External Speaker: 121 x 121 x 72 mm (4.75 x 4.75 x 2.87 in)

**WEIGHT:**

Basic TX/RX Units: 5.94 kg (13.2 lb) **NOTE:** Control units (dash-mount configuration) adds 0.23 kg (0.50 lb). Trunk-mount front cap adds 0.28 kg (0.62 in).

Control units configured as trunk-mount control heads: 0.36 kg (0.80 lb)

Small Remote Control Head: 0.23 kg (0.50 lb)

External Speaker: 0.63 kg (1.38 lb)

**SHOCK AND VIBRATION:** Meets applicable standard of MIL 810C/D



# GENERAL INFORMATION

---

70-3400AD/BD—70-5300AD/BD

## TRANSMITTER

### RF POWER OUTPUT (adjustable):

VHF: 20—40 W and 1—10 W

UHF: 15—30 W and 1—10 W

### FREQUENCY STABILITY:

VHF:  $\pm 0.0005\%$  standard,  $\pm 0.00025\%$  optional

UHF:  $\pm 0.00025\%$

**MODULATION (direct FM):** 16K0F3E, 5 kHz maximum

### FREQUENCY SEPARATION:

VHF/UHF A-Band: 24 MHz

UHF B-Band: 20 MHz

**SPURIOUS AND HARMONICS:** -80 dB

**FM HUM AND NOISE:** -55 dB

**AUDIO RESPONSE:** per EIA and DOC specifications

**AUDIO DISTORTION (at 60% deviation):** 3% or less at 1000 Hz

**OUTPUT IMPEDANCE:** 50  $\Omega$

## RECEIVER

### FREQUENCY STABILITY:

Standard:  $\pm 0.0005\%$

Optional:  $\pm 0.00025\%$

**SENSITIVITY (12 dB SINAD)** 0.35  $\mu$ V

### SELECTIVITY:

VHF ( $\pm 30$  kHz): -90 dB

UHF ( $\pm 25$  kHz): -80 dB

### FREQUENCY SEPARATION:

VHF/UHF A-Band: 24 MHz

UHF B-Band: 20 MHz

**ACCEPTABLE RADIO FREQUENCY**  $\pm 3.5$  kHz minimum

### DISPLACEMENT:

**SPURIOUS REJECTION:** -90 dB

### INTERMODULATION:

VHF -80 dB

UHF -75 dB

**SQUELCH SENSITIVITY:** 0.18  $\mu$ V MAXIMUM

**AUDIO OUTPUT (max):** 12 W at 3% distortion or less

**INPUT IMPEDANCE:** 50  $\Omega$

— Specifications subject to change without notice —

**ACCESSORIES**

- 70-2914..... Controller Card (factory installed)
- 70-7010..... Interface Board (factory installed)
- 70-7011..... Tone Remote Interface
- 70-2037..... DC Remote Interface
- 70-7030..... Rack mount Chassis (requires power supply)
- 70-7031..... Rack mount Chassis with 15 A power supply
- 70-7032..... Option Mounting Shelf
- 70-K30..... Battery Backup Kit
- 71-939..... Repeater Panel
- 71-3400..... VHF High Band 150 W Power Amplifier
- 71-5400..... UHF Band 120 W Power Amplifier
- 71-7200..... External Power Supply
- 71-8813..... PA Control Cable
- 71-8814..... RF Cable Assembly Kit

# GENERAL INFORMATION

---

70-3400AD/BD—70-5300AD/BD

## NOTES

**SECTION 2**

---

**PREPARATION**

# PREPARATION

---

70-3400AD/BD—70-5300AD/BD

## NOTES

**ALIGNMENT REQUIREMENTS**

The SYN-TECH II Duplex product is based on the standard SYN-TECH II radio. The duplex unit incorporates the use of two synthesizer boards instead of one. One operates as the transmit exciter and the other for the receiver local oscillator.

The Logic Board incorporates new firmware in the micom to control the two synthesizers independently. The PA is factory modified and includes the low power kit for that particular radio.

The alignment procedures for the Receiver and the PA can be found in the appropriate manual. This manual only covers the alignment of the transmit exciter synthesizer board for VHF and UHF Bands. The Test Equipment Required Table lists all the test equipment needed to align the entire radio.

**TEST EQUIPMENT REQUIRED**

TEST INSTRUMENT	INSTRUMENT CAPABILITIES	USE
Regulated DC Power Supply	13.6 VDC, 20 A adjustable voltage	Radio power source
RF Wattmeter	75 W, 136—174 MHz (VHF) 50 W, 406—470 MHz (UHF) 50 $\Omega$	Transmitter power measurements
RF Load Resistor	50- $\Omega$ 100 W	Antenna dummy load
Frequency Modulation Meter	136—174 MHz (VHF) 406—470 MHz (UHF) peak responding, $\pm 5$ kHz range	Modulation level measurements
Frequency Meter or Frequency Counter	136—174 MHz (VHF) 406—470 MHz (UHF) 1.0 ppm accuracy	Carrier frequency measurement
Audio Generator	1000 kHz sine-wave 0-3 V <sub>rms</sub> output	Modulation level measurements
RF Signal Generator	136—174 MHz (VHF) 406—470 MHz (UHF) 0.1-1K $\mu$ V output: $\pm 3$ kHz FM mod. with 1 kHz tone	All receiver measurements
Distortion Analyzer	1 kHz notch: 1% measuring range	Receiver performance test and I.F. alignment
Load Resistor (audio)	4 $\Omega$ , 20 W	Speaker load for all receiver measurements
AC Voltmeter	10 mV to 3 V <sub>rms</sub>	Audio level adjustments
Oscilloscope	DC to 500 kHz bandwidth	DCS alignment
Digital Multimeter	0.1 to 20 V DC	Test point measurements and power supply setup
SYN-TECH II Programmer	MIDLAND 70-1080A, or 70-1488 Software and 70-1308 Programming Interface	Manual radio control

# PREPARATION

70-3400AD/BD—70-5300AD/BD

## 70-3400AD/BD ALIGNMENT

The 70-3400AD/BD TX/RX Units are capable of operating over a 24 MHz channel-frequency spread without retuning. The following procedure details exciter alignment and is needed only if a component that affects alignment has been replaced. RADIO REPROGRAMMING (using either the 70-1080A Programmer or 70-1488 PC Programming Software—refer to the appropriate manual) WITH TEST FREQUENCIES IS REQUIRED.

### SETUP

1. Remove the screw securing the coax cover on the bottom and remove cover. Loosen five RX and TX screws securing the duplex cover and carefully lift off of radio. Remove the Rx and Tx coax. Remove four securing screws and the top cover. Loosen two securing screws and the PA Module cover.
2. If not already in place, connect the proper Control Head to the TX/RX Unit.
3. Connect a resistive, 50- $\Omega$  RF load and a watt-meter to the TX Antenna coax. Connect a coax to RX coax cable to the RF generator.
4. Connect 13.6 volts DC power to transceiver J506. Connect [+] to pin 2 and [-] to pin 1.
5. Connect a 4- $\Omega$ , 20-W resistor to pins 4 and 6 of the Accessory Plug. The jumper between pin 5 and 6 must be temporarily disconnected to make this connection, if equipped. The resistor serves as a constant load to replace the speaker's inconsistencies.

**CAUTION:** Both speaker terminals are LIVE! Never ground either one. Connect grounded receiver--audio measuring equipment to **only one side** of the speaker, and chassis ground. Normally, voltage measurements will be half of true values.

6. Turn the radio on, set the VOLUME control to a mid-position, and set the SQUELCH control fully counterclockwise.
7. Connect the 70-1080A Programmer to Programming Port J909. Upload the radio programming Data-Packet into the Programmer and initiate its Remote control Mode. Refer to The 70-1080A Operator's Manual for instructions.

### TRANSMITTER SYNTHESIZER

#### • VCO Resonance

Refer to **Figure 2 - 1**.

1. Select the Remote-Control Mode of the Programmer and enter a test transmit frequency of 136.00 MHz for A-Band radios, or 150.00 MHz for B-Band radios.
2. Activate the transmit mode (using the Programmer). Adjust LOW-CHANNEL TX TANK L1722 (labeled "TX L") to obtain 2.0 volts DC on CM1118-pin 3.
3. Change the TX test frequency to 148.500 MHz for A-Band radios, or 162.600 for B-Band radios.
4. Activate transmit, then adjust HIGH-CHANNEL TX TANK L1732 (labeled "TX H") to obtain 2.0 V DC on CM1118-pin 3.

#### • Reference Oscillator

5. Initiate transmit on any channel. Measure transmitted RF carrier frequency without modulation and, if necessary, adjust REFERENCE OSCILLATOR X1101 for zero carrier frequency offset (within 100 Hz of channel frequency if using a frequency counter).

### MODULATOR ALIGNMENT

Always perform Modulator Alignment in its entirety. The following adjustments are interactive. Refer to **Figure 2 - 1**.

#### • Programing Channels

Temporarily program Channels 1, 2, and 3 as follows:

	A-Band	B-Band	Code/Tone
Channel 1	154.10 MHz	168.15 MHz	+023
Channel 2	136.00 MHz	150.00 MHz	100 Hz
Channel 3	160.00 MHz	174.00 MHz	None

• **Reference-Oscillator Modulating Port**

1. Set RV1102 (on TX Synthesizer side) to minimum. Select Channel 1, and initiate transmit.
2. Observe modulation level of the recovered waveform and adjust TONE2 RV1101 so that its peaks equal desired DCS modulation level (typically  $\pm 750$  Hz).

• **Modulation Limiting**

Two deviation limit adjustments exist: one for channels in the upper half of the frequency band, the other for the lower half.

3. Select Channel 2.
4. Disconnect the hand microphone from its front panel receptacle P317. Apply 3  $V_{rms}$  of 1000 Hz signal to pin 1 of MIC JACK P317, then initiate transmit (if not using the 70-1080A Programmer, ground P317-pin 4). Measure total carrier deviation and, if needed, adjust FL MOD LIMIT RV1104 to obtain  $\pm 5$  kHz.
5. Select Channel 3.
6. Apply 3  $V_{rms}$  of 1000 Hz signal to pin 1 of MIC JACK P317, then initiate transmit. Measure

total carrier deviation and, if needed, adjust  $F_H$  MOD LIMIT RV1105 to obtain  $\pm 5$  kHz.

7. Apply 310 mV to pin 1 of P317 and adjust RV103 for 3 kHz.
8. Repeat steps 4 through 7. **NOTE:** If the 70-2914 option is installed the adjustment of RV5 will affect the adjustment of RV103 so that 3 kHz may not be achieved. If so, adjust RV103 to maximum.

• **VCO Modulation Port**

9. Select Channel 1.
10. While observing recovered modulation on an oscilloscope, fine-tune TONE1 RV1102 for a square DCS waveform as shown in **Figure 2 - 2**.

**WARNING:** Use equipment with DC coupling to avoid distortion of the DCS waveform that contains frequencies as low as 6 Hz.

**NOTE:** Observe the DCS waveform at pin 10 of J1121 with an oscilloscope for a better example. The recovered DCS waveform above should be identical to it.

**70-5300AD/BD ALIGNMENT**

The 70-5300AD/BD TX/RX Units are capable of operating over a 24 MHz (A-Band), or 20 MHz (B-Band) channel-frequency spread without retuning. The following procedure details exciter alignment and is needed only if a component that affects alignment has been replaced. RADIO REPROGRAMMING (using either the 70-1080A Programmer or 70-1488 PC Programming Software—refer to the appropriate manual) WITH TEST FREQUENCIES IS REQUIRED.

**SETUP**

1. Remove the screw securing the coax cover on the bottom and remove cover. Loosen five RX and TX screws securing the duplex cover and carefully lift off of radio. Remove the RX and TX coax. Remove four securing screws and the top cover. Loosen two securing screws and the PA Module cover.
2. If not already in place, connect the proper Control Head to the TX/RX Unit.
3. Connect a resistive, 50- $\Omega$  RF load and a wattmeter to the TX Antenna coax. Connect a coax to RX coax cable to the RF generator.

4. Connect 13.6 volts DC power to transceiver J506. Connect [+] to pin 2 and [-] to pin 1.
5. Connect a 4- $\Omega$ , 20-W resistor to pins 4 and 6 of the Accessory Plug. The jumper between pin 5 and 6 must be temporarily disconnected to make this connection, if equipped. The resistor serves as a constant load to replace the speaker's inconsistencies.

**CAUTION:** Both speaker terminals are LIVE! Never ground either one. Connect grounded receiver--audio measuring equipment to **only one side** of the speaker, and chassis ground. Normally, voltage measurements will be half of true values.





## PREPARATION

70-3400AD/BD—70-5300AD/BD

6. Turn the radio on, set the VOLUME control to a mid-position, and set the SQUELCH control fully counterclockwise.
7. Connect the 70-1080A Programmer to Programming Port J909. Upload the radio programming Data-Packet into the Programmer and initiate its Remote control Mode. Refer to appropriate manual for instructions.

### TRANSMITTER SYNTHESIZER

#### • VCO Resonance

Refer to **Figure 2 - 1**.

1. Select the Remote-Control Mode of the Programmer and enter the a transmit test frequency of 406.00 MHz for A-Band radios, or 450.00 MHz for B-Band radios.
2. Activate the transmit mode (using the Programmer). Adjust LOW-CHANNEL TX TANK L1722 (labeled "TX L") to obtain 2.0 volts DC on CM1118-pin 3.
3. Change the test frequencies to 419.20 MHz for A-Band radios, or 460.80 MHz for B-Band radios.
4. Activate transmit, then adjust HIGH-CHANNEL TX TANK L1732 (labeled "TX H") to obtain 2.0 V DC on CM1118-pin 3.

#### • Reference Oscillator

5. Initiate transmit on any channel. Measure transmitted RF carrier frequency without modulation and, if necessary, adjust REFERENCE OSCILLATOR X1101 for zero carrier frequency offset (within 100 Hz of channel frequency if using a frequency counter).

### MODULATOR ALIGNMENT

Always perform Modulator Alignment in its entirety. The following adjustments are interactive. Refer to **Figure 2 - 1**.

#### • Programing Channels

Temporarily program Channels 1, 2, and 3 as follows:

	A-Band	B-Band	Code/Tone
Channel 1	419.20 MHz	460.80 MHz	+023
Channel 2	406.00 MHz	450.00 MHz	100 Hz

#### • Reference-Oscillator Modulating Port

1. Set RV1102 (on TX Synthesizer side) to minimum. Select Channel 1.
2. Observe modulation level of the recovered waveform and adjust TONE2 RV1101 so that its peaks equal desired DCS modulation level (typically  $\pm 750$  Hz).

#### • Modulation Limiting

Two deviation limit adjustments exist: one for channels in the upper half of the frequency band, the other for the lower half.

3. Select Channel 2.
4. Disconnect the hand microphone from its front panel receptacle P317. Apply 3  $V_{rms}$  of 1000 Hz signal to pin 1 of MIC JACK P317, then initiate transmit (if not using the 70-1080A Programmer, ground P317-pin 4). Measure total carrier deviation and, if needed, adjust FL MOD LIMIT RV1104 to obtain  $\pm 5$  kHz.
5. Select Channel 1.
6. Apply 3  $V_{rms}$  of 1000 Hz signal to pin 1 of MIC JACK P317, then initiate transmit. Measure total carrier deviation and, if needed, adjust FH MOD LIMIT RV1105 to obtain  $\pm 5$  kHz.
7. Apply 310 mV to pin 1 of P317 and adjust RV103 for 3 kHz.
8. Repeat steps 4 through 7. **NOTE:** If the 70-2914 option is installed the adjustment of RV5 will affect the adjustment of RV103 so that 3 kHz may not be achieved. If so, adjust RV103 to maximum.

#### • VCO Modulation Port

9. While observing recovered modulation on an oscilloscope, fine-tune TONE1 RV1102 for a square DCS waveform as shown in **Figure 2 - 2**.

**WARNING:** Use equipment with DC coupling to avoid distortion of the DCS waveform that contains frequencies as low as 6 Hz.

**NOTE:** Observe the DCS waveform at pin 10 of J1121 with an oscilloscope for a better example. The recovered DCS waveform above should be identical to it.

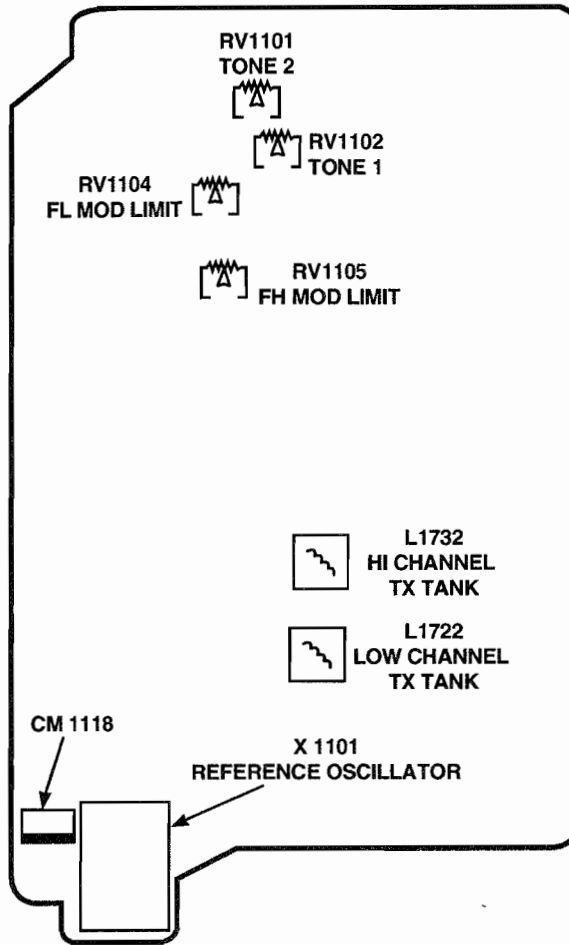

Figure 2 - 1 — Adjustment Map

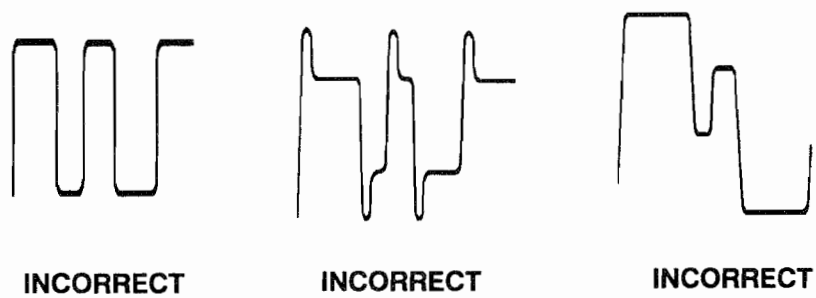

Figure 2 - 2 — DCS Waveforms

# PREPARATION

---

70-3400AD/BD—70-5300AD/BD

## NOTES

**SECTION 3**

**SERVICING**

# SERVICING

---

70-3400AD/BD—70-5300AD/BD

## NOTES

## ACCESSING DUPLEXER HOUSING

### REMOVING DUPLEXER HOUSING

The duplexer housing is mounted to the radio chassis. To remove the duplexer housing (refer to **Figure 3 - 1**) :

1. Turn the radio over to expose the bottom of the duplexer housing (251).
2. There is one screw (505) fastening a metal plate (252) to the duplexer housing. Remove this screw, and the metal plate. The RF cables will need to be disconnected from the duplexer or antenna jacks (whichever is installed) to completely separate the duplexer housing from the radio chassis. These cables may be accessed through the holes in the duplexer housing.
3. There are five recessed screws (525) on the bottom of duplexer housing. Loosen these five screws.
4. Lift the duplexer housing away from the radio.

You may now make adjustments to the PA Board, or RF Board. Refer to Section 2 of the appropriate service manual (70-340380 for 70-3400AD/BD, or 70-530000 for 70-5300AD/BD).

You may also make adjustments to the Duplexer, as described below.

### REPLACING DUPLEXER WITH ANTENNA JACKS

You may wish to remove the duplexer and replace it with separate antenna jacks. To do so:

1. Locate the antenna jack (J1101) at the back of the duplexer housing (251). In the port next to it, an additional antenna jack will need to be installed (order Midland Part Number 70-159799 for the jack, and 70-151356 for each of the two screws required to mount it).
2. Remove hole plug (254) from duplexer housing. Install the second antenna jack in the hole plug cavity. Secure with the two screws.

3. Route the RX RF cable from the RF Board to the jack labeled RX; route the TX RF cable from the PA Board to the jack labeled TX.

The radio is ready to be reassembled.

### INSTALLING/REMOVING A DUPLEXER

#### • Installing a 70-D02 Duplexer (70-3400AD/BD Only)

1. With the duplexer labels facing up, place the antenna port end of the duplexer (250) against the stops at the antenna end of the duplexer housing (251). Gently lower the duplexer in place. Two alignment pins will pass through two of the holes on the opposite ends of the duplexer.
2. Place the metal bracket (253) on the duplexer housing. Attach the two screws (504) used to secure the bracket in place.

#### • Installing a 70-D03 Duplexer (70-5300AD/BD Only)

1. With the duplexer labels facing down, place the antenna port end of the duplexer (250) over the stops at the antenna end of the duplexer housing (251). Gently lower the duplexer into the housing. Make sure that there is a space between the opposite end of the duplexer and the duplexer housing.
2. Place the two metal brackets (253) on the duplexer housing. Secure each with two screws (504).

#### • Removing a Duplexer

1. Remove the two screws (504) from both brackets (253).
2. Remove the bracket, then lift the duplexer (250) out of the housing.

The duplexer is now ready for retuning or replacing.

# SERVICING

70-3400AD/BD—70-5300AD/BD

## REASSEMBLY

1. Place the duplexer housing (251) under the radio chassis.
2. Re-connect the RF cables to the duplexer or antenna jacks (whichever are installed).
3. There are five recessed screws (525) are on the bottom of duplexer housing. Tighten these five screws.
4. Place metal plate (252) onto the duplexer housing. Secure with screw (505).

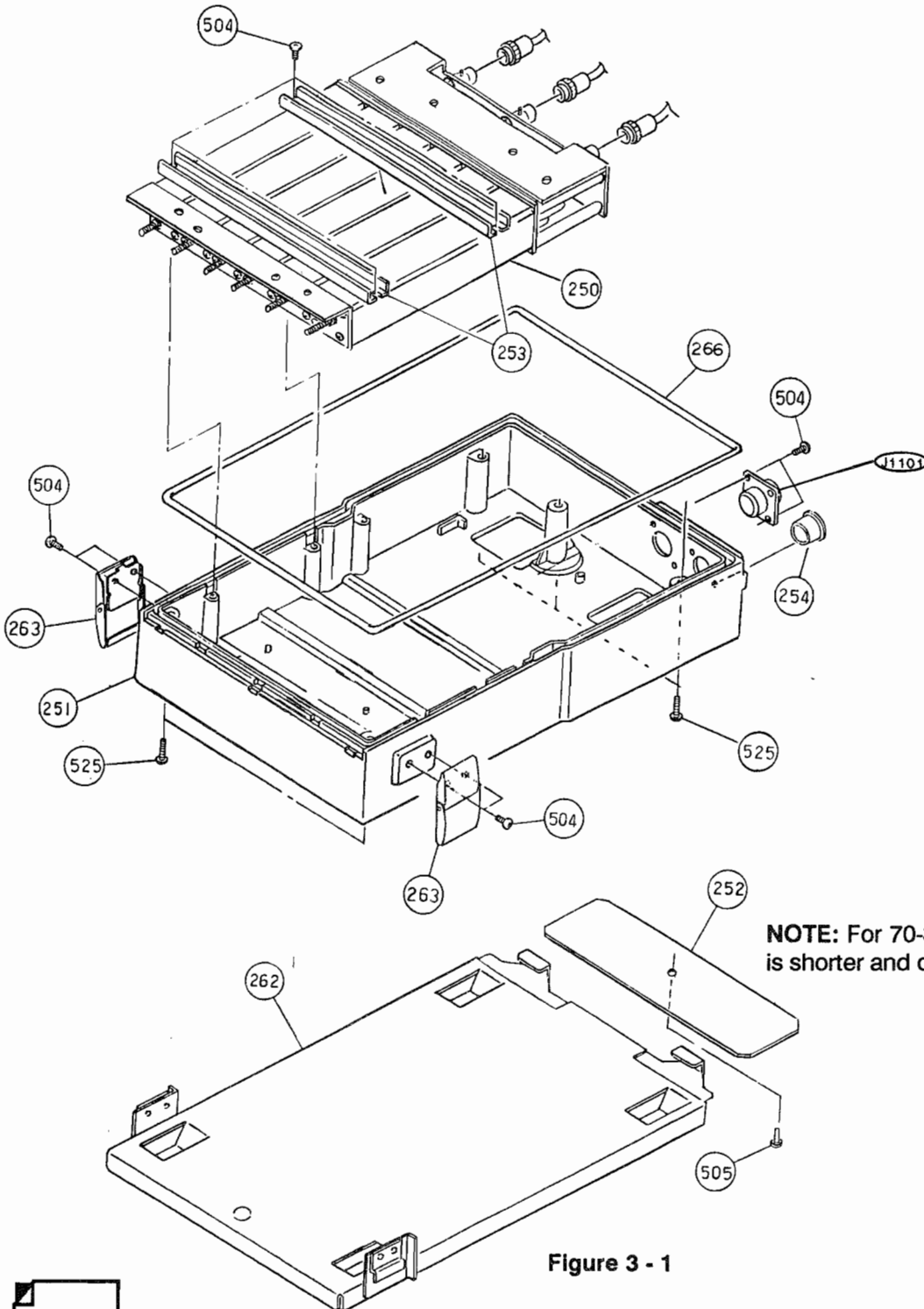

**NOTE:** For 70-3400AD/BD, duplexer is shorter and oriented label side up.

Figure 3 - 1

A B C D E F G H I J K L

1  
2  
3  
4  
5  
6  
7  
8

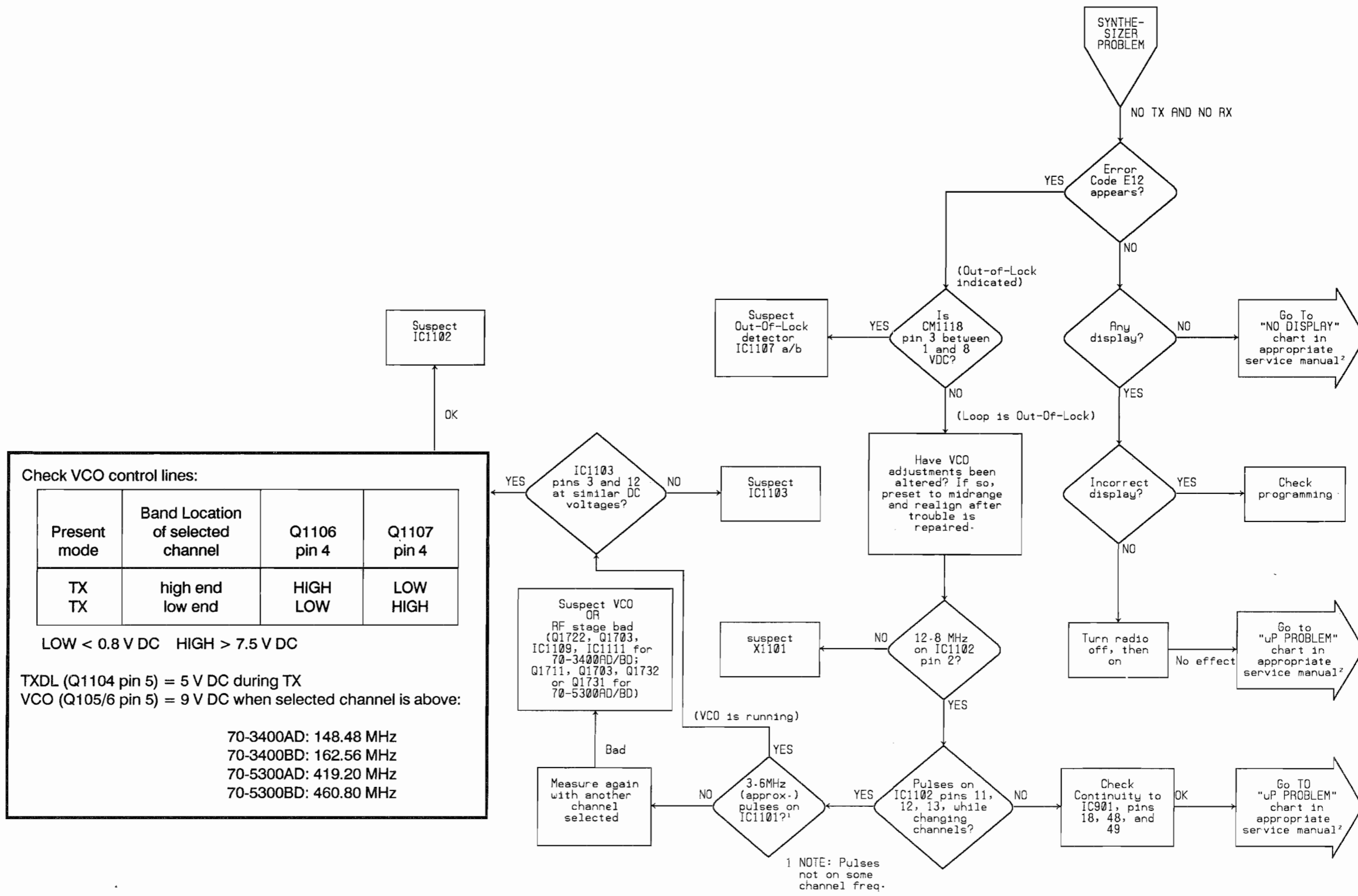

Check VCO control lines:

Present mode	Band Location of selected channel	Q1106 pin 4	Q1107 pin 4
TX	high end	HIGH	LOW
TX	low end	LOW	HIGH

LOW < 0.8 V DC HIGH > 7.5 V DC

TXDL (Q1104 pin 5) = 5 V DC during TX  
 VCO (Q105/6 pin 5) = 9 V DC when selected channel is above:

70-3400AD: 148.48 MHz  
 70-3400BD: 162.56 MHz  
 70-5300AD: 419.20 MHz  
 70-5300BD: 460.80 MHz

1 NOTE: Pulses not on some channel freq.

<sup>2</sup> For 70-3400AD/BD, use 70-340380  
 For 70-5300AD/BD, use 70-530000

Troubleshooting Chart 3 - 1 — Synthesizer Problem



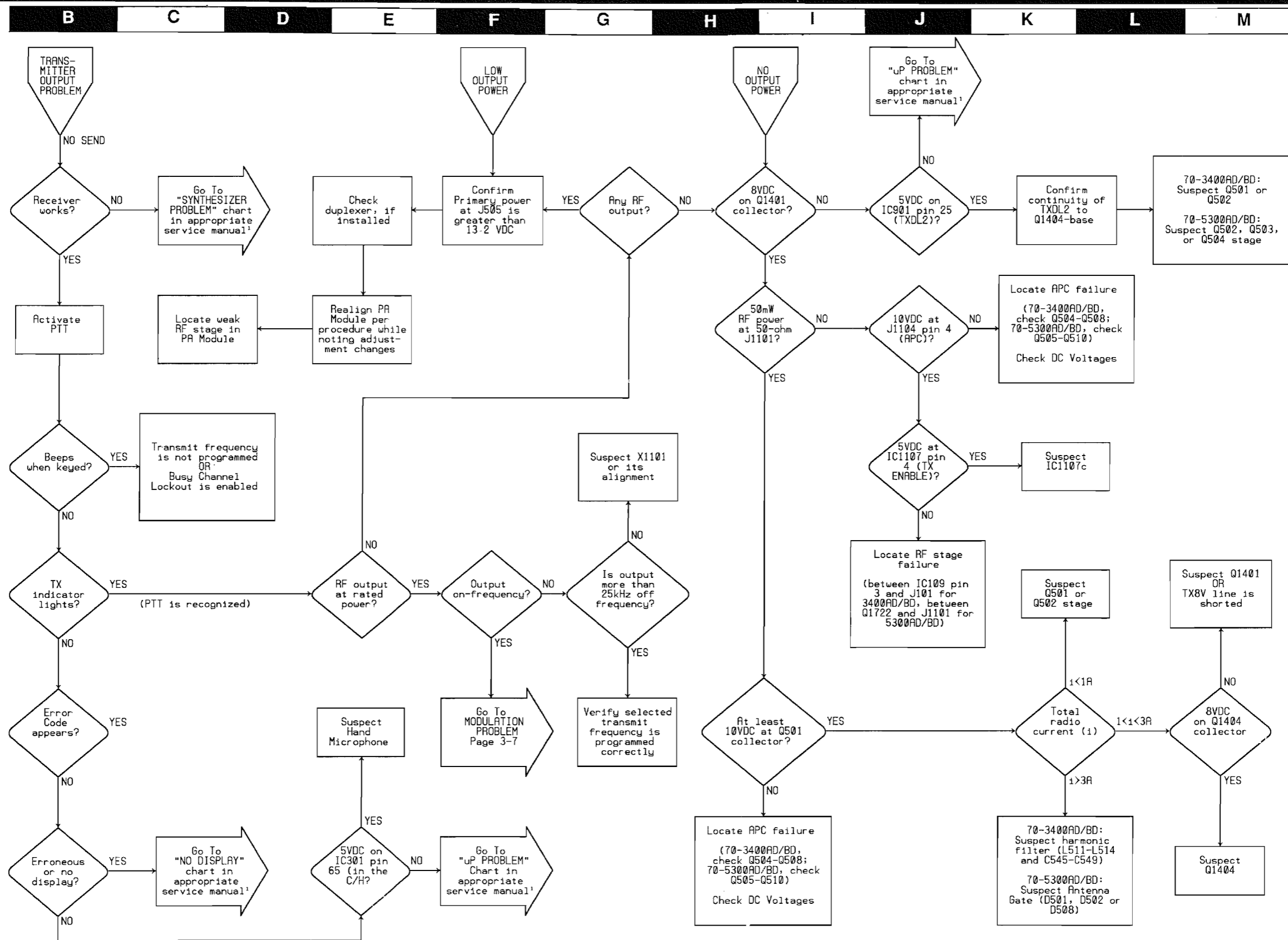

Troubleshooting Chart 3 - 2 — Transmitter & Power Output Problems

<sup>1</sup> For 70-3400AD/BD, use 70-340380  
For 70-5300AD/BD, use 70-530000

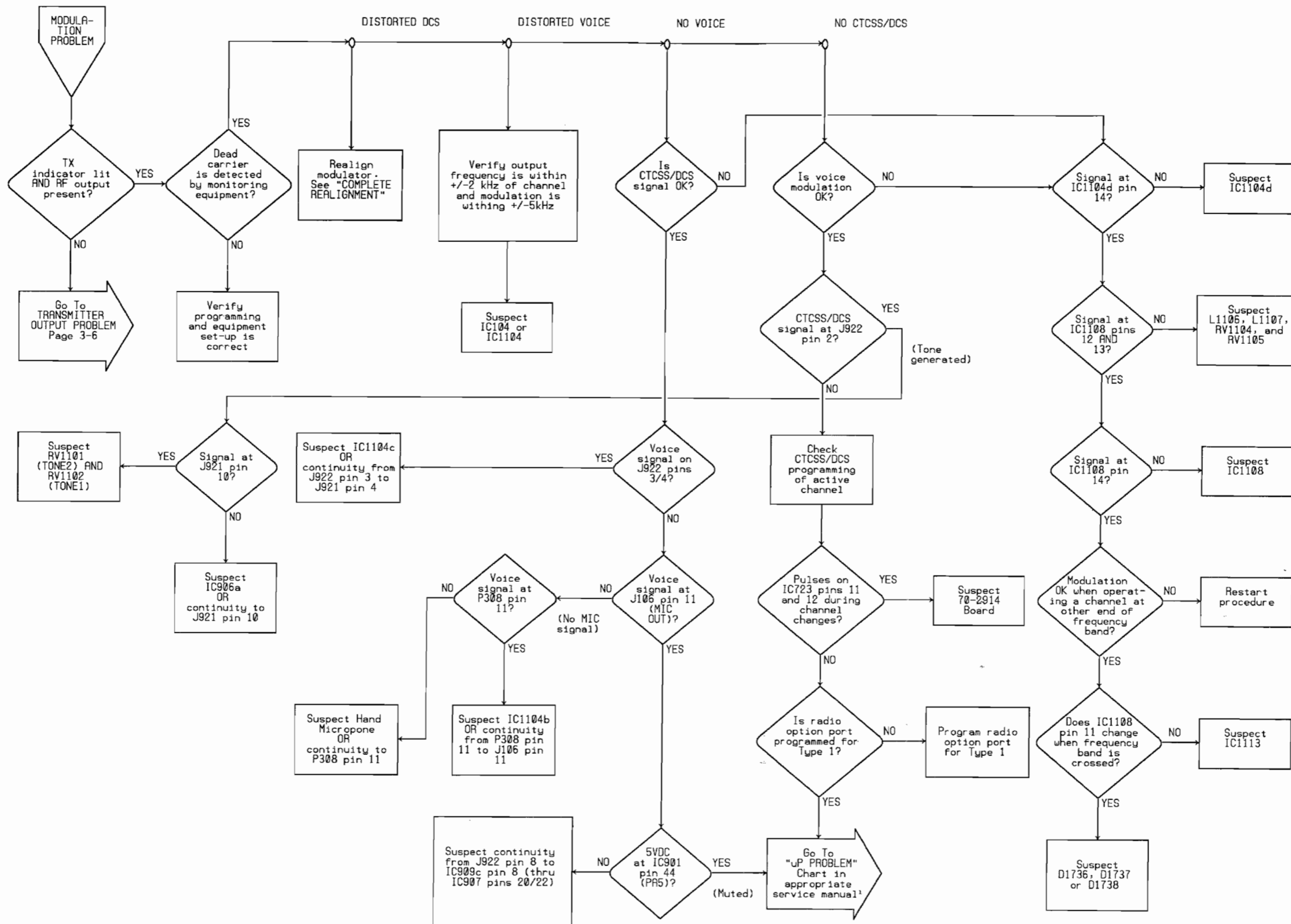

<sup>1</sup> For 70-3400AD/BD, use 70-340380  
 For 70-5300AD/BD, use 70-530000

Troubleshooting Chart 3 - 3 — Modulation Problem

**SERVICING**

70-3400AD/BD—70-5300AD/BD

<b>B</b>	<b>C</b>	<b>D</b>	<b>E</b>	<b>F</b>	<b>G</b>	<b>H</b>	<b>I</b>	<b>J</b>	<b>K</b>	<b>L</b>	<b>M</b>
----------	----------	----------	----------	----------	----------	----------	----------	----------	----------	----------	----------

- 1
- 2
- 3
- 4
- 5
- 6
- 7
- 8

NOTES

**SECTION 4**

---

**CIRCUIT DESCRIPTIONS**

# CIRCUIT DESCRIPTIONS

---

70-3400AD/BD—70-5300AD/BD

## NOTES

The Full Duplex SYN-TECH II radio unit is comprised of four major PC boards: the Logic Board, which contains a microcomputer and its peripheral interface circuits; the RF Board, which contains the receiver frequency synthesizer, receiver, and receive audio amplifier circuits; Transmit Exciter Board, which contains the transmitter frequency synthesizer, transmit modulator; and the PA Module, which contains the transmitter RF power amplifier. Refer to the appropriate service manual for information about the Logic and RF board. The Transmit Exciter Board and the PA Module are described in this section. The Serial-Data Peripherals for the Logic Board and Transmit Audio Routing are also described here.

## 70-3400AD/BD CIRCUIT DESCRIPTION

### TRANSMIT EXCITER BOARD

The Transmit Exciter Board is located on the top side of the Duplex TX/RX unit and occupies only one half on the topside area. The other half is occupied by the Logic Board.

#### • Transmitter Synthesizer

Radio frequency signals for the transmitter is produced by transmit voltage-controlled oscillator (VCO) in a phase-lock loop (PLL) configuration.

#### • Voltage Controlled Oscillator

In this radio, Q1721 operates to generate the transmit frequencies. It is buffered by Q1722. Output of the buffer is amplified by Q1703 and stage-gain hybrids IC1109 and IC1111. Intermediate RF output of IC1111 is applied to the PLL dividers. RF signal from the last output of IC1111 is amplified further by the PA Module. The resonance of each VCO is adjusted by a DC steering voltage which is produced by the remainder of the phase-lock loop, and which appears at IC1103. When the frequency of the VCO output drifts away from the desired value, the loop adjusts the steering voltage to compensate. Because of this tracking characteristic, VCO steering voltage is always greater with higher VCO output frequencies (unless the band split is crossed).

Because of circuit parameters, a single VCO tank cannot tune across the entire 24 MHz channel spread. The VCO contains two electrically-tunable tank circuits L1722 and L1732. Only one of the two tanks is switched in at a time and they are selected by the VCO CNT output of IC1113 and TXDL from the Logic Board. The microcomputer sets VCO CNT to logic low when operating channel frequency is below a band-split point and it sets TXDL to logic high during transmit mode. Q1103, Q1106 and Q1107 produce two tank-selecting voltages from VCO CNT and TXDL: VCO-TX-8V and VCO-TX-LO. Each tank-selecting voltage applies forward bias to a PIN diode D1726 that connects a respective in-

ductance-capacitance network to oscillator Q1721. Each network is independently calibrated by L1722 or L1732.

Resonance of each VCO tank is voltage-tuned by varactor diodes D1721—D1724 and D1731—D1734 respectively. Loop steering voltage applies reverse bias to all these varactor diodes simultaneously. As steering voltage increases, varactor diode capacitance decreases; thus, net capacitance in each tank decreases, which increases resonant frequency of the tanks.

#### • Loop Dividers

The amplitude of the VCO signal from IC1111 pin 3 is sufficient to feed prescaling frequency divider IC1101, which applies an output pulse to IC1102 pin 10 once every 128 or 129 input cycles. Additional frequency division is performed within IC1102 to produce 2.5 kHz. Frequency division by IC1101 is switched from 129 to 128 sometime between each of its output pulses and back to 129 during the start of each of those pulses. This provides vernier division of channel frequencies that do not divide evenly. 128/129 division is controlled by a programmable pulse counter in IC1102 that applies control logic voltages to IC1101 control input at pin 1.

X1101 is a temperature-compensated crystal oscillator that produces a reference frequency of exactly 12.8 MHz. This reference frequency is divided by IC1102 to produce 2.5 kHz that is compared to the down-counted 2.5 kHz sample of VCO output. Phase and/or frequency error between each 2.5 kHz signal produces current pulses that pass through IC1102-pin 17. Depending on whether the phase difference of the comparator inputs is positive or negative, current pulses flow into or out of IC1102, which charges or discharges C1122 through loop filter IC1103. The DC voltage developed across C1122 serves as VCO steering, which is first applied through an active filter within IC1103 to limit loop response. Normally, the loop response is slowed enough by the active filter to block 2.5 kHz

## CIRCUIT DESCRIPTIONS

70-3400AD/BD—70-5300AD/BD

reference noise and prevent loop correction of voice modulation during transmit. Higher active filter rolloff frequency is selected by the microcomputer system on the Logic Board when the radio changes channels or it is keyed and unkeyed, by a logic low applied to pin 6. This increase in loop response speeds locking time.

A connection from an intermediate point in the phase/frequency comparator in IC1102 is made at pin 12. When the loop is out of lock, the down-counted VCO sample is not in phase with the 2.5 kHz reference and low-going pulses appear here, which produce a logic low at pins 12 and 13 of IC1107-a. This logic low is applied back to the microcomputer system as status input, plus it is inverted by IC1107-c to switch on Q1113. Q1113 then clamps off bias to transmit RF preamplifier Q1112 to prevent emission of erratic signals generated by the uncontrolled VCO.

### • Modulator

Voice signals from the hand-microphone are applied to microphone amplifier IC104-b through MIC GAIN adjustment RV103, located on the RF Board. Amplified microphone signals exit the RF Board and connect through optional circuitry that may be connected to the Logic Board. Voice signals are sent to the Transmit Exciter Board to IC1104-c where frequency response is pre-emphasized. Signals are amplified further by IC1104-d. Gain is such that stronger signals bring IC1104-d output into clipping, which limits modulation. Harmonics above the 3 kHz modulation pass-band are removed by the 2.5 kHz pi-network comprised of L1106/L1107. Modulation signals are then adjusted by RV1104/RV1105 so that modulation at limiting will produce transmitted carrier deviation of 5 kHz.  $F_L$  MOD LIMIT RV1104 provides maximum deviation calibration when the operating channel is below the band-split frequency;  $F_H$  MOD LIMIT RV1105 provides maximum deviation calibration when the operating channel is above the band-split.

RV1104/RV1105-tap signals produce variations in reverse bias voltages across varactor diodes in the transmit VCO tank circuit. The varying capacitance of these diodes causes variations in resonance and output frequency, thus frequency modulation results.

Low frequency CTCSS tone and DCS code signals for transmission are sent from the Logic Board and applied to both IC1104-a and RV1102. TONE1

RV1102 applies these signals to the modulator after the pre-emphasis portion. Because the lowest frequency that can modulate the VCO is much higher than the lowest DCS signal frequency (6 Hz), the DCS/CTCSS signals are also applied to the synthesizer reference oscillator (via IC1104-a) where the 12.8 MHz reference is also frequency modulated. The reference-oscillator modulation port has a low-pass characteristic with rolloff determined by the loop filter response, while the VCO modulation port has a high-pass characteristic with rolloff determined by the same element; therefore, combined modulation through both ports can be perfectly flat if both ports are amplitude-balanced. TONE2 RV1101 adjusts signal amplitude into the reference oscillator port, and it must be calibrated so that a low frequency signal (under 20 Hz) produces the same RF carrier deviation as would an equal amplitude, but higher frequency (over 200 Hz) signal. While TONE2 only adjusts modulation levels of lower frequency portion of DCS signals, TONE1 adjusts modulation levels of both higher frequency portions of DCS signals and CTCSS tones.

### • Transmit RF Preamplifier

Synthesizer output at IC1111-pin 7 is modulated, on-channel RF signal that is ready for amplification and emission. Q1112 is a preamplifier that feeds the coaxial cable that couples the RF signal to the PA Module. DC source current to the Q1112-collector circuit is regulated by the Automatic Power Control (APC) circuitry on the PA Module.

## 40-W PA MODULE

The 40-W Power Amplifier (PA) Module is the rear portion of the Duplex TX/RX unit. It contains RF circuitry that is accessible by removing its cover.

### • RF Power Amplifier

A 50- $\Omega$  coaxial cable from the TX RF preamplifier connects to J501. A PC-board stripline is used to match the base of Q501 terminal to the coax and CV501 fine-tunes this match by balancing reactance. RF impedance at the collector of Q501 is transformed by PC-board stripline to the base terminal of driver Q502, and the collector of Q502 is transformed to the base of Q503. RF impedance at the collector of final-stage Q503 is again transformed by PC stripline and fine tuned by CV504 to match circuit impedance at RF-gate D501. L511—L514 and C545—C549 comprise the harmonic filter. R512 and R513 serve to drain static and other DC potentials from the antenna.

- **Antenna Gate**

There is no antenna gate required with this duplex radio. The output of the PA amplifier (J502) and the input to the receiver (J203) are coupled through separate antenna connectors. The separate receive signal and transmit signal can then be combined with an internal or external duplexer. These RF signal lines can also be coupled to external antennas.

- **Automatic Power Control**

A PC stripline ahead of the harmonic filter, plus a thin PC runner adjacent to it, serve as a directional coupler. D503 rectifies a small RF sample that is developed across the thin runner; thus producing a DC voltage that increases with RF power travelling

forward into the antenna. This power-level sensing voltage is the inverting input of a differential amplifier comprised of Q506 and Q507. The non-inverting input is a DC voltage produced by the H.PWR adjustment RV502. Differential amplifier output drives Q504 which is a current source that feeds primary DC to the collector circuits of both predriver Q501 and preamplifier Q112. The feedback loop, from the directional coupler to Q504, holds RF output power at the constant level determined by RV502.

If the radio is equipped with the Low Power Option, Q505 reduces the H.PWR set-point by connecting L.PWR adjustment RV501 in parallel with RV502 when a logic high is applied to J504-pin 5. Q508 is also biased on to increase the sensitivity of the differential amplifier.

## 70-5300AD/BD CIRCUIT DESCRIPTION

### TRANSMIT EXCITER BOARD

The Transmit Exciter Board is located on the top side of the Duplex TX/RX unit and occupies only one half on the topside area. The other half is occupied by the Logic Board.

- **Transmitter Synthesizer**

Radio frequency signals for the transmitter is produced by transmit voltage-controlled oscillator (VCO) in a phase-lock loop (PLL) configuration.

- **Voltage Controlled Oscillator**

In this radio, Q1721 operates to generate the transmit frequencies. It is doubled by Q1722. Output is buffered by Q1703, Q1731 and Q1733. Intermediate RF output of Q1732 is applied to the PLL dividers. RF signal from the last output of Q1112 is amplified further by the PA Module. The resonance of each VCO is adjusted by a DC steering voltage which is produced by the remainder of the phase-lock loop, and which appears at IC1103 pin 12. When the frequency of the VCO output drifts away from the desired value, the loop adjusts the steering voltage to compensate. Because of this tracking characteristic, VCO steering voltage is always greater with higher VCO output frequencies (unless the band split is crossed).

Because of circuit parameters, a single VCO tank cannot tune across the entire channel spread (24 MHz A-Band, 20 MHz B-Band). The VCO con-

tains two electrically-tunable tank circuits L1722 and L1732. Only one of the two tanks is switched in at a time and they are selected by the VCO CNT output of IC1113 and TXDL from the Logic Board. The microcomputer sets VCO CNT to logic low when operating channel frequency is below a band-split point and it sets TXDL to logic high during transmit mode. Q1103, Q1106 and Q1107 produce two tank-selecting voltages from VCO CNT and TXDL: VCO-TX-HI and VCO-TX-LO. Each tank-selecting voltage applies forward bias to a PIN diode D1726 that connects a respective inductance-capacitance network to oscillator Q1721. Each network is independently calibrated by L1722 or L1732.

Resonance of each VCO tank is voltage-tuned by varactor diodes D1721—D1724 and D1731—D1734 respectively. Loop steering voltage applies reverse bias to all these varactor diodes simultaneously. As steering voltage increases, varactor diode capacitance decreases; thus, net capacitance in each tank decreases, which increases resonant frequency of the tanks.

- **Loop Dividers**

The amplitude of the VCO signal from Q1732 is sufficient to feed prescaling frequency divider IC1101, which applies an output pulse to IC1102-pin 10 once every 128 or 129 input cycles. Additional frequency division is performed within IC1102 to produce 12.5 kHz. Frequency division by IC1101



## CIRCUIT DESCRIPTIONS

70-3400AD/BD—70-5300AD/BD

is switched from 129 to 128 sometime between each of its output pulses and back to 129 during the start of each of those pulses. This provides vernier division of channel frequencies that do not divide evenly. 128/129 division is controlled by a programmable pulse counter in IC1102 that applies control logic voltages to IC1101 control input at pin 6.

X1101 is a temperature-compensated crystal oscillator with a frequency stability of 2.5 ppm. This produces a reference frequency of exactly 12.8 MHz. The reference frequency is divided by IC1102 to produce 12.5 kHz that is compared to the down-counted 12.5 kHz sample of VCO output. Phase and/or frequency error between each 12.5 kHz signal produces current pulses that pass through IC1102-pin 17. Depending on whether the phase difference of the comparator inputs is positive or negative, current pulses flow into or out of IC1102, which charges or discharges C1122 through loop filter IC1103. The DC voltage developed across C1122 serves as VCO steering, which is first applied through an active filter within IC1103 to limit loop response. Normally, the loop response is slowed enough by the active filter to block 12.5 kHz reference noise and prevent loop correction of voice modulation during transmit. Higher active filter roll-off frequency is selected by the microcomputer system on the Logic Board when the radio changes channels or it is keyed and unkeyed, by a logic low applied to pin 1. This increase in loop response speeds locking time.

A connection from an intermediate point in the phase/frequency comparator in IC1102 is made at pin 9. When the loop is out of lock, the down-counted VCO sample is not in phase with the 12.5 kHz reference and low-going pulses appear here, which produce a logic low at pins 12 and 13 of IC1107-a. This logic low is applied back to the microcomputer system as status input, plus it is inverted by IC1107-c to switch on Q1113. Q1113 then clamps off bias to transmit RF preamplifier Q1112 to prevent emission of erratic signals generated by the uncontrolled VCO.

### • Modulator

Voice signals from the hand-microphone are applied to microphone amplifier IC104-b through MIC GAIN adjustment RV103, located on the RF Board. Amplified microphone signals exit the RF Board and

connect through optional circuitry that may be connected to the Logic Board. Voice signals are sent to the Transmit Exciter Board to IC1104-c where frequency response is pre-emphasized. Signals are amplified further by IC1104-d. Gain is such that stronger signals bring IC1104-d output into clipping, which limits modulation. Harmonics above the 3 kHz modulation pass-band are removed by the 2.5 kHz pi-network comprised of L1106/L1107. Modulation signals are then adjusted by RV1104/RV1105 to so that modulation at limiting will produce transmitted carrier deviation of 5 kHz.  $F_L$  MOD LIMIT RV1104 provides maximum deviation calibration when the operating channel is below the band-split frequency;  $F_H$  MOD LIMIT RV1105 provides maximum deviation calibration when the operating channel is above the band-split.

RV1104/RV1105-tap signals produce variations in reverse bias voltages across varactor diodes in the transmit VCO tank circuit. The varying capacitance of these diodes causes variations in resonance and output frequency, thus frequency modulation results.

Low frequency CTCSS tone and DCS code signals for transmission are sent from the Logic Board and applied to both IC1104-a/RV1101 and RV1102. TONE1 RV1102 applies these signals to the modulator after the pre-emphasis portion. Because the lowest frequency that can modulate the VCO is much higher than the lowest DCS signal frequency (6 Hz), the DCS/CTCSS signals are also applied to the synthesizer reference oscillator (via IC1104-a and RV1101) where the 12.8 MHz reference is also frequency modulated. The reference-oscillator modulation port has a low-pass characteristic with roll-off determined by the loop filter response, while the VCO modulation port has a high-pass characteristic with roll-off determined by the same element; therefore, combined modulation through both ports can be perfectly flat if both ports are amplitude-balanced. TONE2 RV1101 adjusts signal amplitude into the reference oscillator port, and it must be calibrated so that a low frequency signal (under 20 Hz) produces the same RF carrier deviation as would an equal amplitude, but higher frequency (over 200 Hz) signal. While TONE2 only adjusts modulation levels of lower frequency portion of DCS signals, TONE1 adjusts modulation levels of both higher frequency portions of DCS signals and CTCSS tones.

- **Transmit RF Preamplifier**

Synthesizer output at Q1733 is modulated, on-channel RF signal that is ready for amplification and emission. Q1112 is a preamplifier that feeds the coaxial cable that couples the RF signal to the PA Module. DC source current to the Q1112-collector circuit is regulated by the Automatic Power Control (APC) circuitry on the PA Module.

### 30-W PA MODULE

The 30-W Power Amplifier (PA) Module is the rear portion of the Duplex TX/RX unit. It contains RF circuitry that is accessible by removing its cover.

- **RF Power Amplifier**

A 50- $\Omega$  coaxial cable from the TX RF preamplifier connects to J501. A PC-board stripline is used to match the base of Q501. RF impedance at the collector of Q501 is transformed by PC-board stripline to the base terminal of driver Q502, and the collector of Q502 is transformed PC-board stripline to the base of Q503. RF impedance at the collector of Q503 is transformed by PC stripline and fine tuned by CV501 to the base of final-stage Q504. RF impedance at the collector of final-stage Q504 is again transformed by PC stripline and fine tuned by CV502 to match circuit impedance of the low pass filter. L503—L507 and C518—C521 comprise the harmonic filter. R504 and R505 serve to drain static and other DC potentials from the antenna.

- **Antenna Gate**

There is no antenna gate required with this duplex radio. The output of the PA amplifier (J502) and the input to the receiver (J203) are coupled through separate antenna connectors. The separate receive signal and transmit signal can then be combined with an internal or external duplexer. These rf signal lines can also be coupled to external antennas.

- **Automatic Power Control**

A PC stripline ahead of the harmonic filter, plus a thin PC runner adjacent to it, serve as a directional coupler. D503 rectifies a small RF sample that is developed across the thin runner; thus producing a DC voltage that increases with RF power travelling forward into the antenna. This power-level sensing voltage is inverting input of a differential amplifier comprised of Q506 and Q507. The non-inverting input is a DC voltage produced by the H.PWR adjustment RV502. Differential amplifier output drives Q510 which is a current source that feeds primary DC to the collector circuits of both predriver Q501. The feedback loop, from the directional coupler to Q504, holds RF output power at the constant level determined by RV502.

If the radio is equipped with the Low Power Option, Q505 reduces the H.PWR set-point by connecting L.PWR adjustment RV501 in parallel with RV502 when a logic high is applied to J504-pin 5. Q508 is also biased on to increase the sensitivity of the differential amplifier.

## LOGIC BOARD — SERIAL-DATA PERIPHERALS

The Logic Board is located on the top side of the TX/RX unit and occupies only half of the topside area. The other half is occupied with the Transmit Exciter Board.

Serial data output PA0, with its corresponding clock PA1 (IC901 pins 48 and 49), is used to program the 70-2914 Board, frequency synthesizer IC102, RF controller IC113 on the RF Board, frequency synthesizer IC1102, RF controller IC1113 on the Transmit Exciter Board, the OP IC, and an add-on option board connected to P923. The serial data selects CTCSS tone frequency, selects synthesizer division ratios, switches control lines, and controls optional

circuitry. When serial data applied from PA0 is CTCSS tone-frequency information, the microcomputer pulses output-port P64 to instruct IC907 to latch and use that data. When data is for IC102, IC113, IC1102 and/or IC1113, microcomputer port PB0 is pulsed to force them to latch the data. Data to IC102, IC113, IC1102 and IC1113 is applied in two bursts: one burst programs two of three IC102 dividers, the second burst programs a third IC102 divider and IC113. The third burst programs two of three IC1102 dividers and the fourth burst programs a third IC102 divider and IC113.

## CIRCUIT DESCRIPTIONS

---

70-3400AD/BD—70-5300AD/BD

### TRANSMIT AUDIO ROUTING

Most of the remaining circuitry on the Logic Board routes, detects, or produces audio signals. The following descriptions refer to the Audio Routing Schematic. Microcomputer control and input ports are denoted with labeled ovals on the schematic.

Audio signal from the hand microphone is level calibrated by MIC GAIN RV103 and pre-amplified on the RF Board. It is then routed through JP902 on the Logic Board, through audio gate IC909-c, and back to the modulator on the RF Board. IC909-c is controlled by the PA5 output port, which applies a logic low to mute voice signals during tone transmission. IC1104-c on the Transmit Exciter Board amplifies and pre-emphasizes voice signals. IC1104-d amplifies stronger signals into limiting and L1106/L1107 filters resultant signals and harmonics above 3 kHz. RV1104 and RV1105 calibrate limited signal before it frequency modulates the VCO so that the peak amplitude produces 5-kHz carrier deviation. RV1104 is switched into the circuit when the active

channel frequency is below or equal to the mid-band crossover frequency (for VHF A-Band radios, 148.48 MHz; for VHF B-Band radios, 162.56 MHz, for UHF A-Band radios, 419.6 MHz; or for UHF B-Band radios, 460.8 MHz ). RV1105 is switched in if channel frequency is above the crossover.

During transmit, both DCS and CTCSS tones are produced by the 70-2914 Board. The signals are then routed to the Transmit Exciter Board. The signal is applied into the TONE input of the modulator where it is split: one side routes into the voice limiter for modulating the VCO; the other side is amplified by IC1104a and used to frequency-modulate the phase-lock loop reference oscillator. RV1101 and RV1102 adjust gain of each route to balance frequency response so that the TONE modulator-input port is flat from below 10 Hz to above 2.5 kHz.

**SECTION 5**

---

**DIAGRAMS**

**DIAGRAMS**

70-3400AD/BD—70-5300AD/BD

**NOTES**

**DUPLEXER WIRING DIAGRAM**

**70-0001 WIRING DIAGRAM —UNDER-DASH**

70-3400AD/BD—70-5300AD/BD

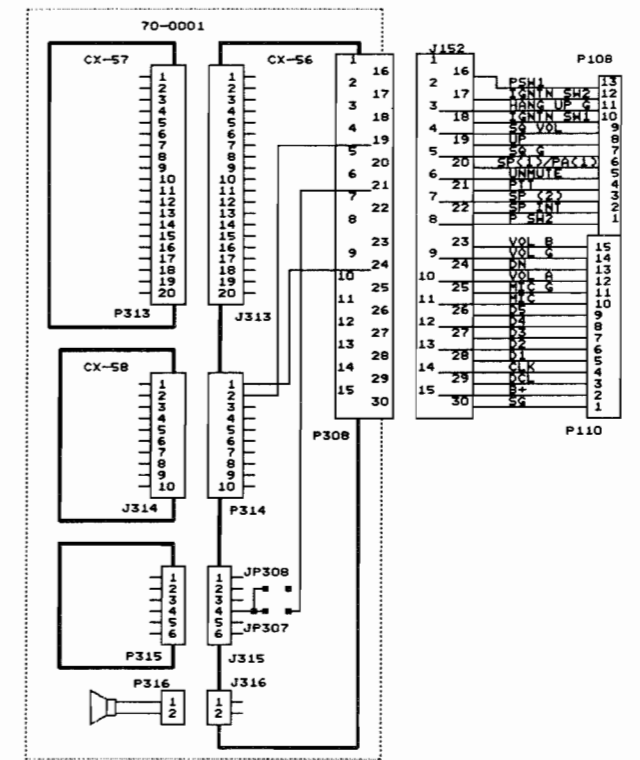
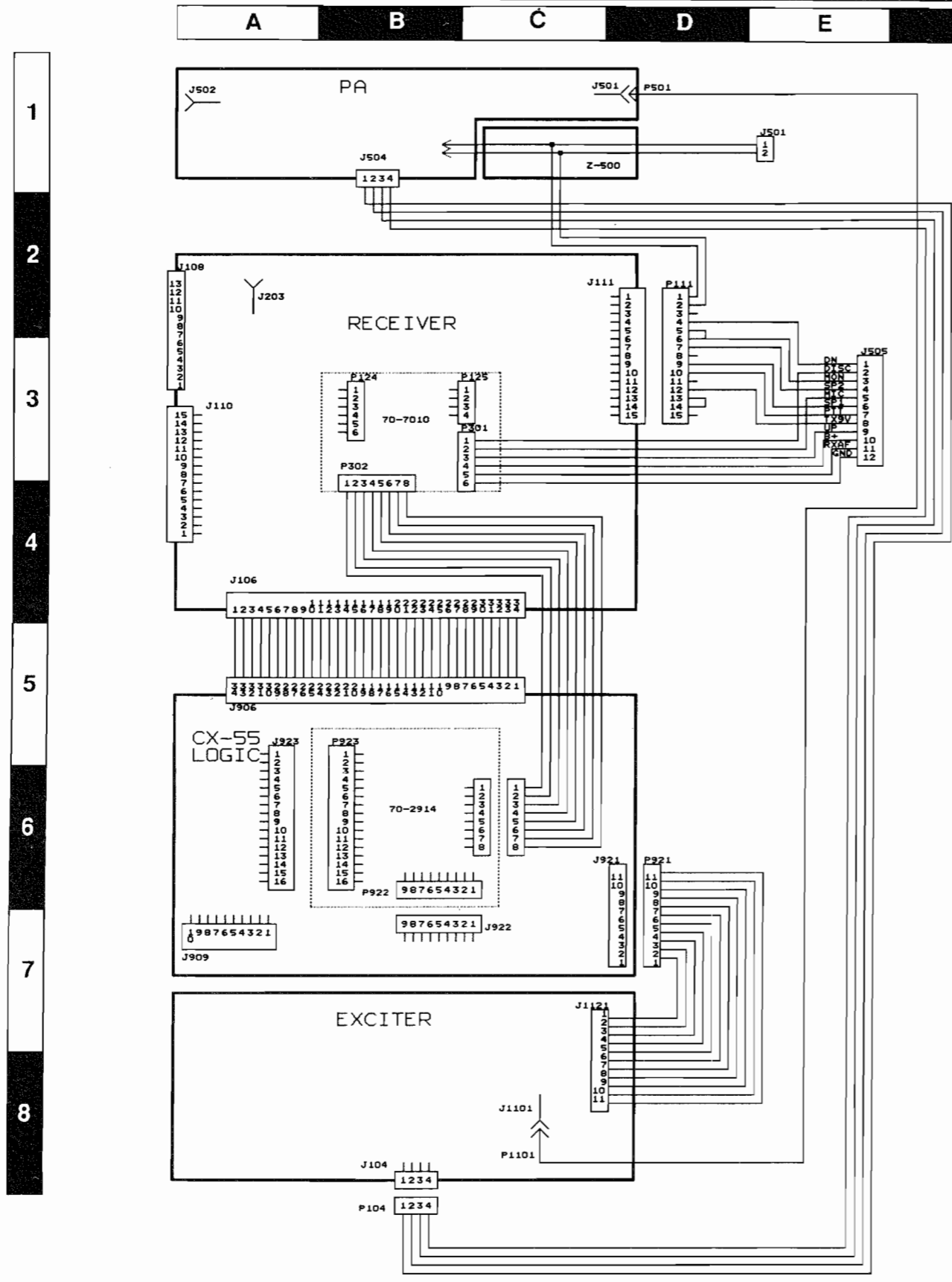

**70-0001 WIRING DIAGRAM —TRUNK-MOUNT**

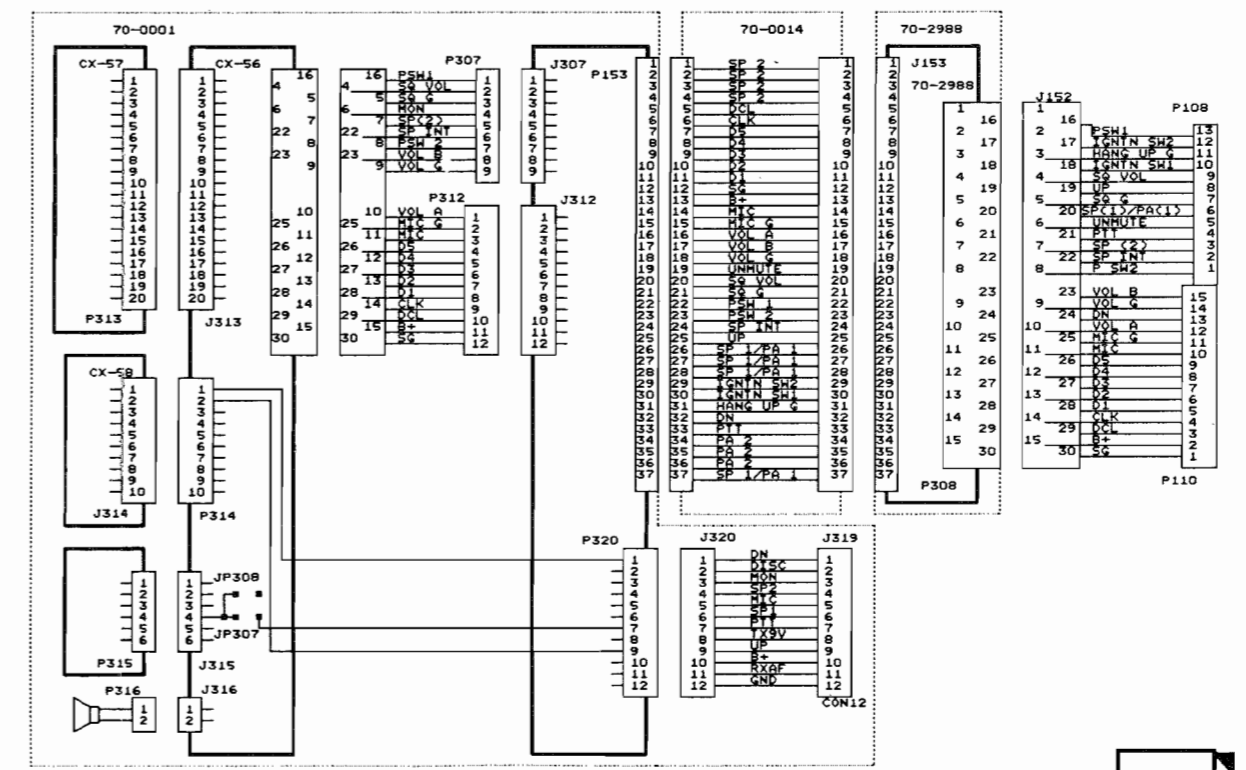

70-3400AD/BD—70-5300AD/BD

B C D E F G H I J K L M

1  
2  
3  
4  
5  
6  
7  
8

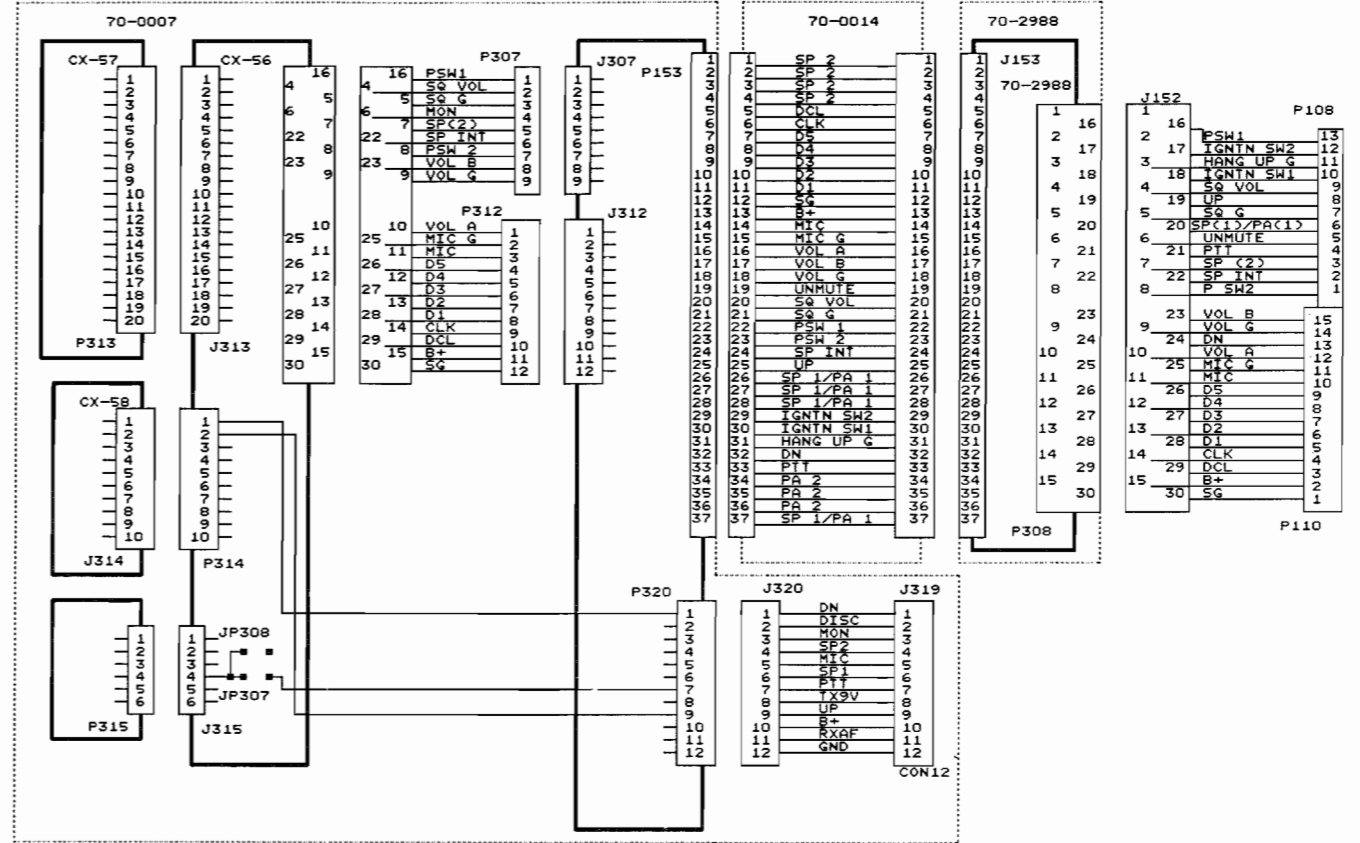
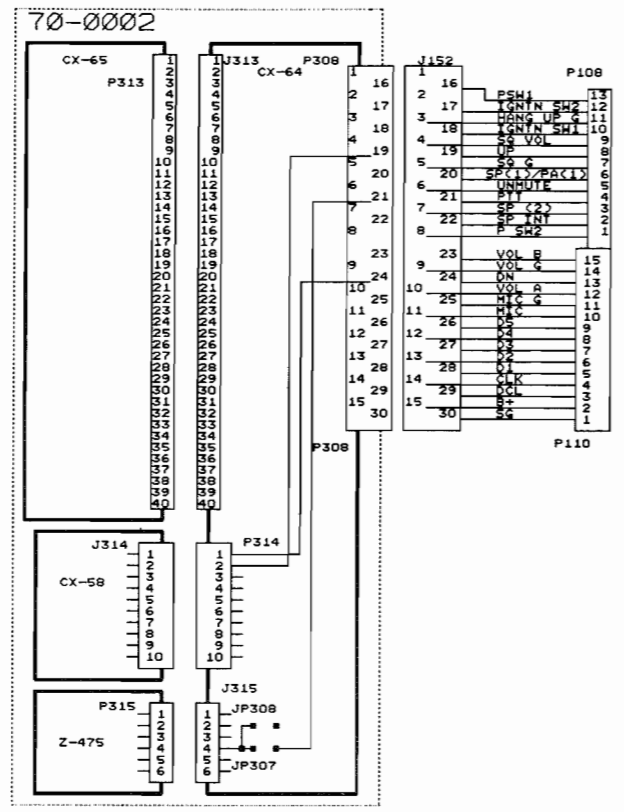

70-0002 WIRING DIAGRAM —TRUNK-MOUNT

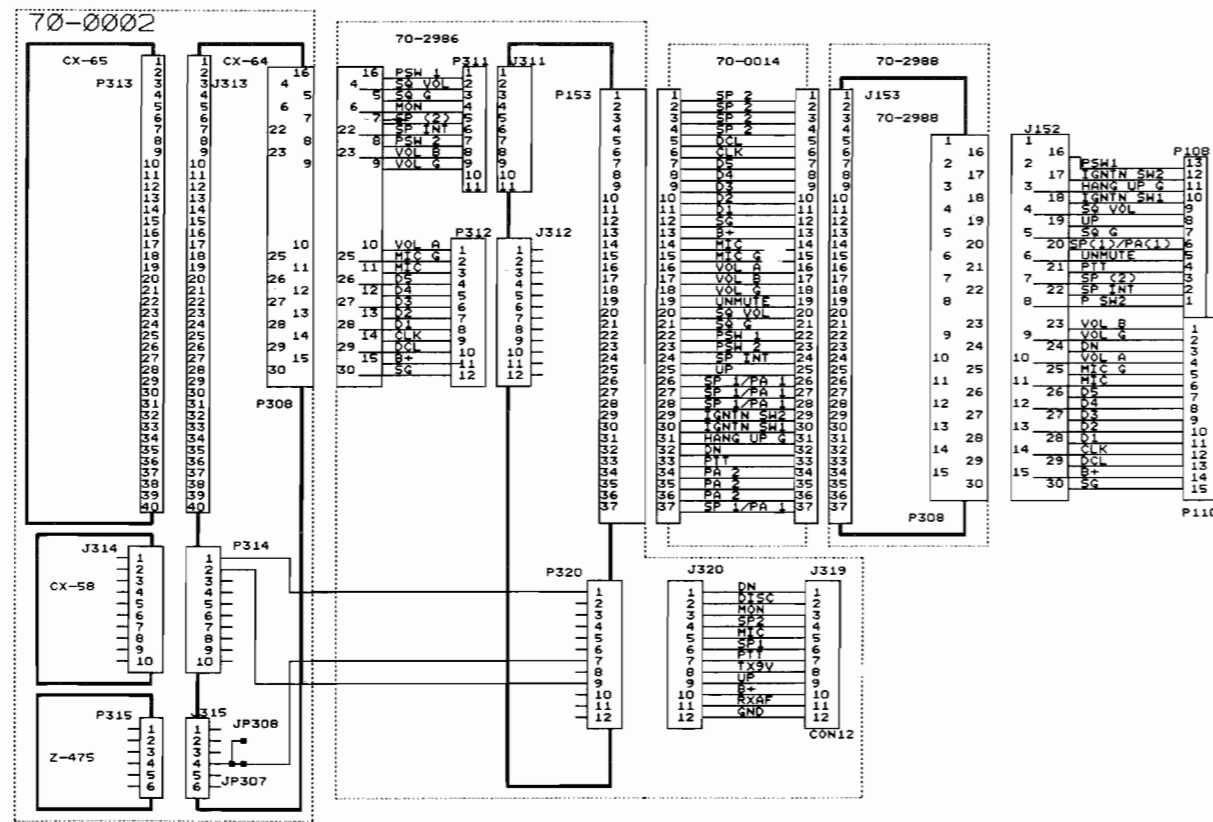

A B C D E F G H I J K L

1  
2  
3  
4  
5  
6  
7  
8

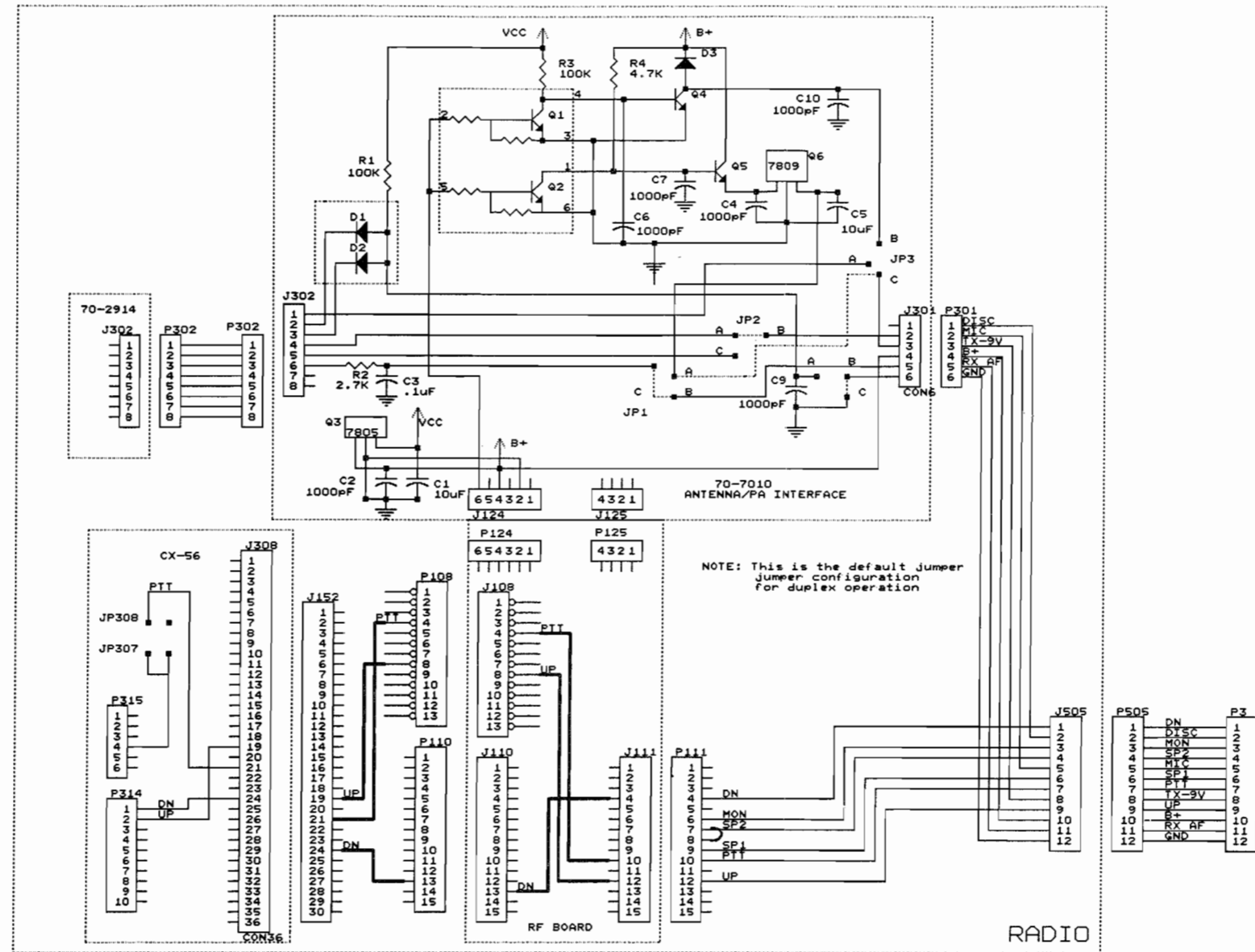



# 70-3400AD/BD BLOCK DIAGRAM

70-3400AD/BD—70-5300AD/BD

B C D E F G H I J K L M

## TRANSMITTER

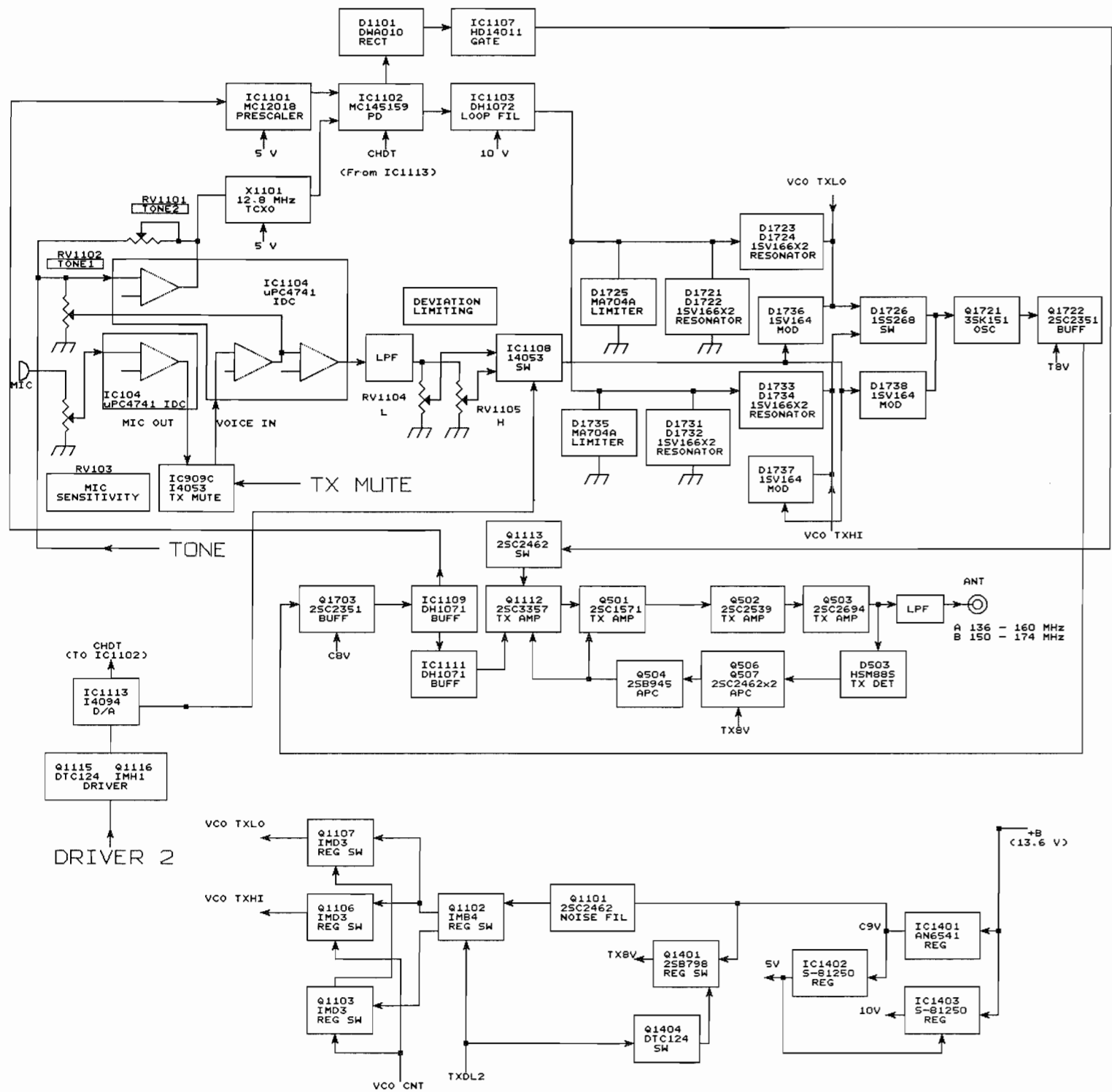

## RECEIVER/LOGIC

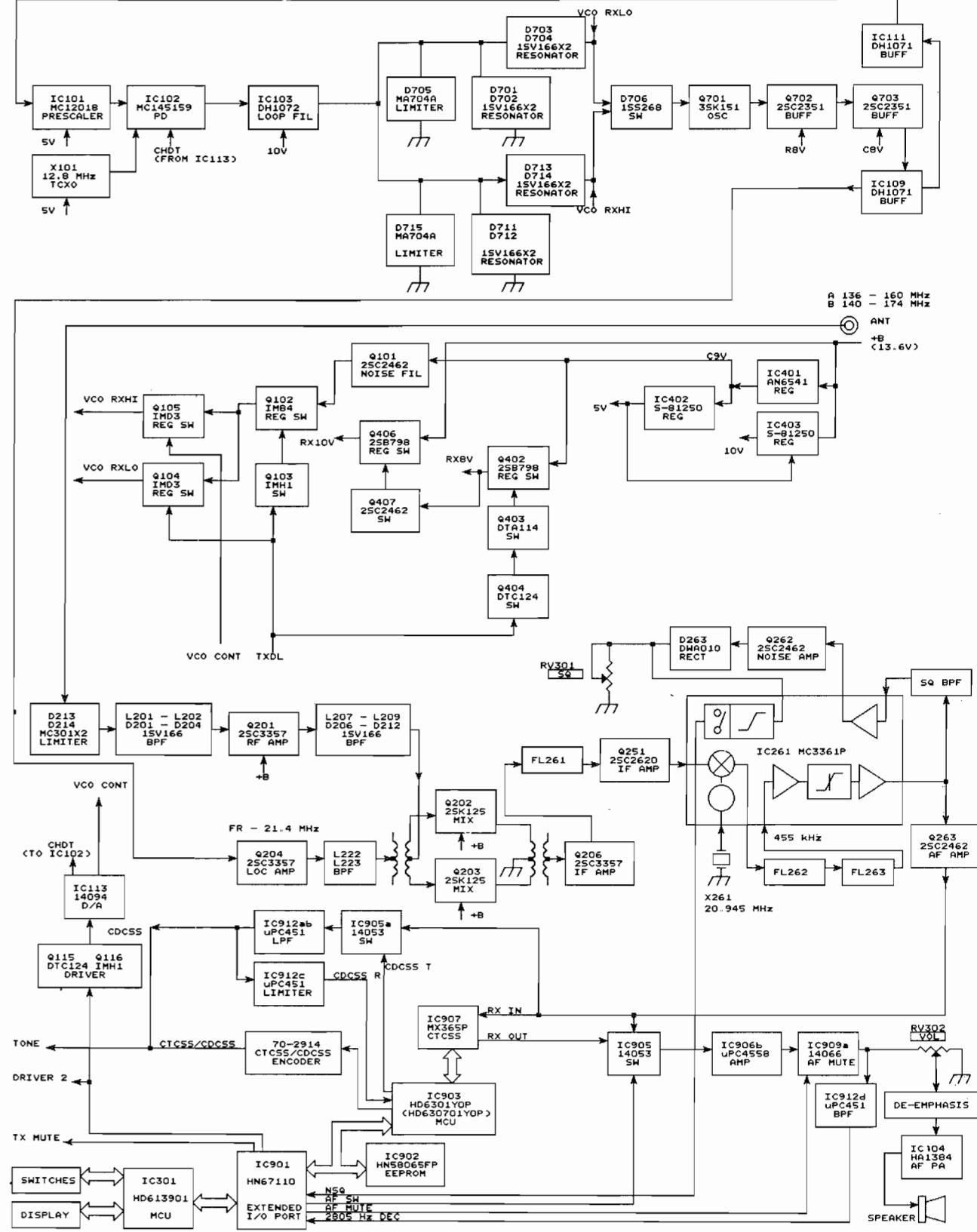

A B C D E F G H I J K L

1  
2  
3  
4  
5  
6  
7  
8

TRANSMITTER

RECEIVER/LOGIC

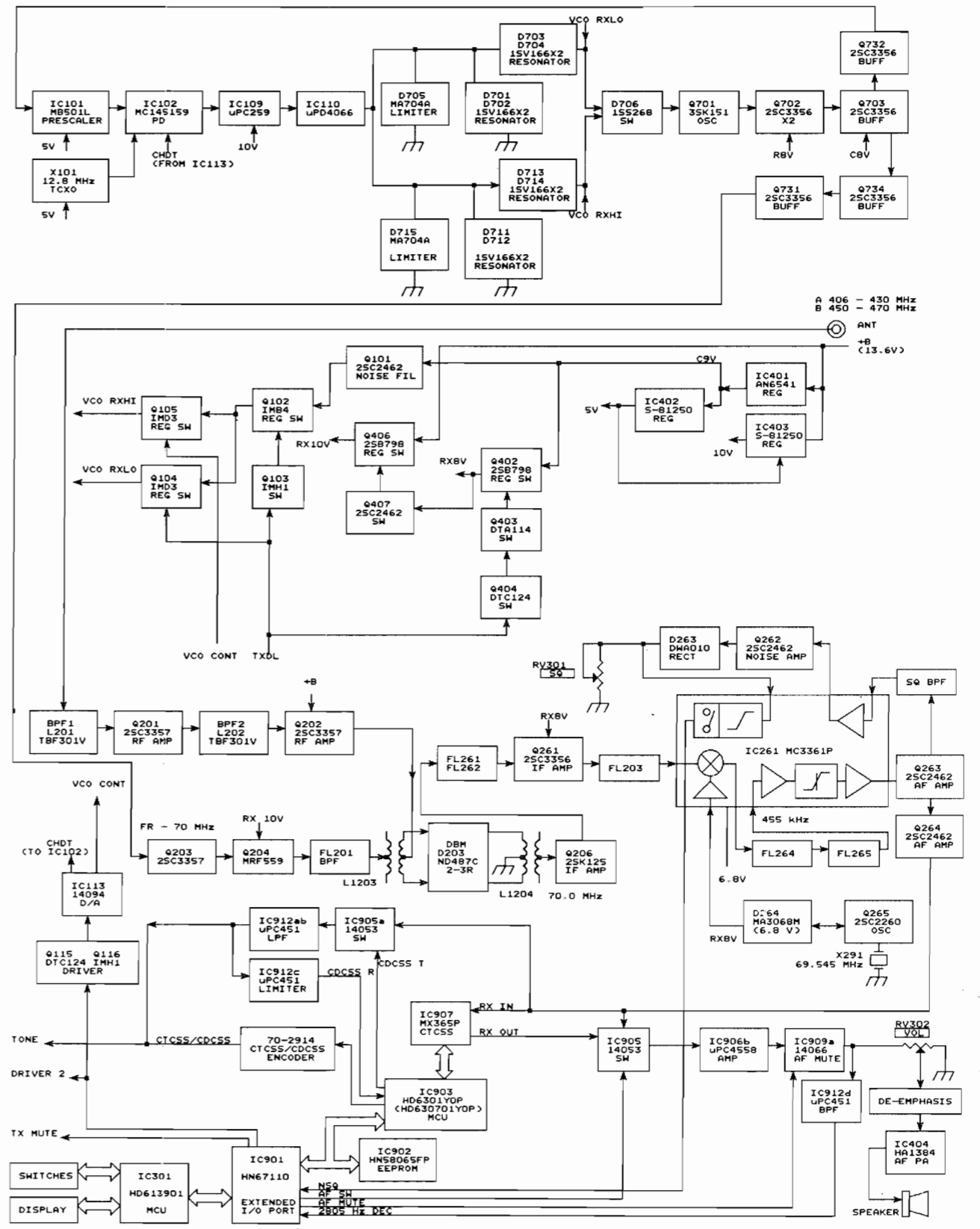
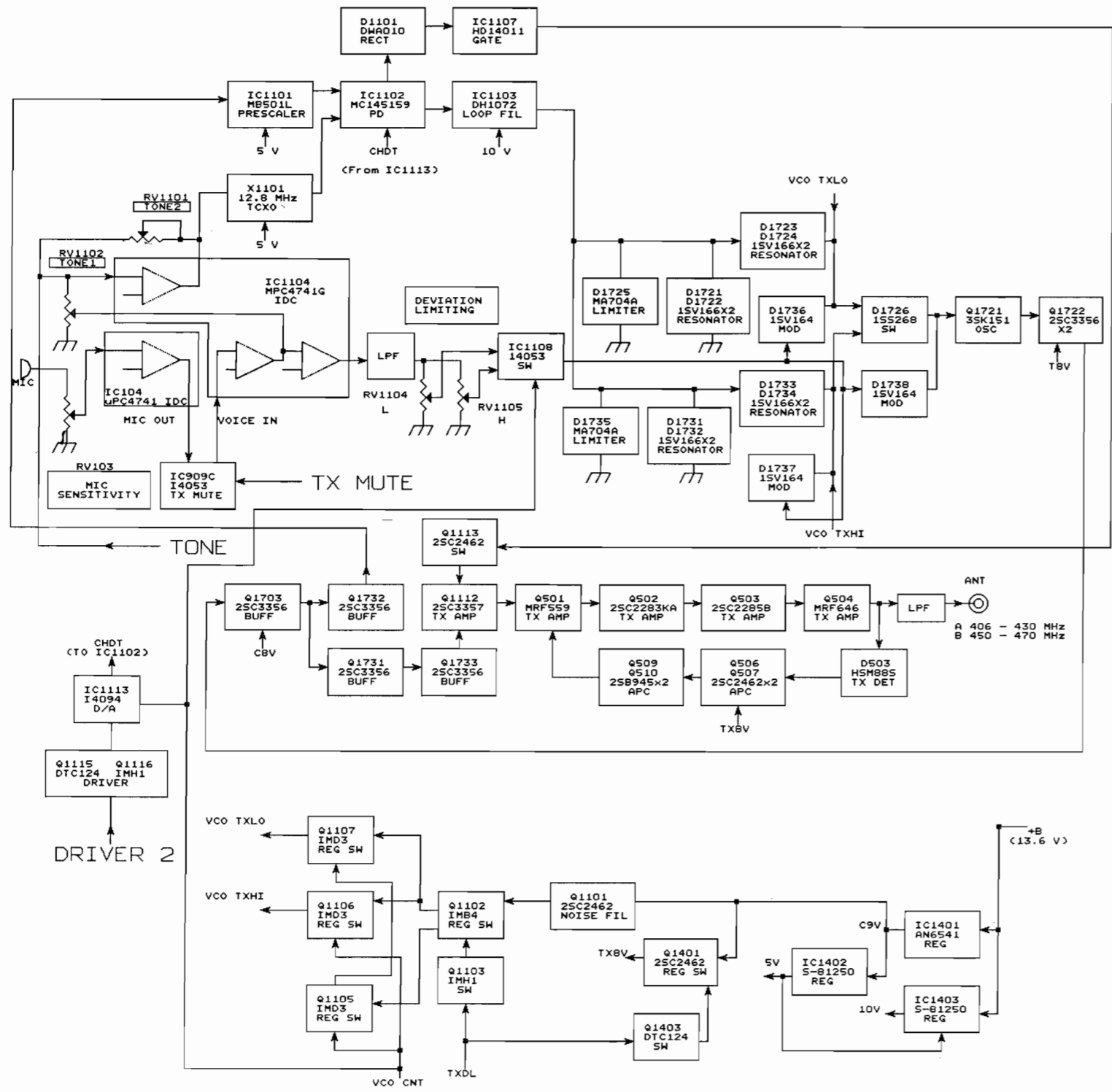

TOP VIEW

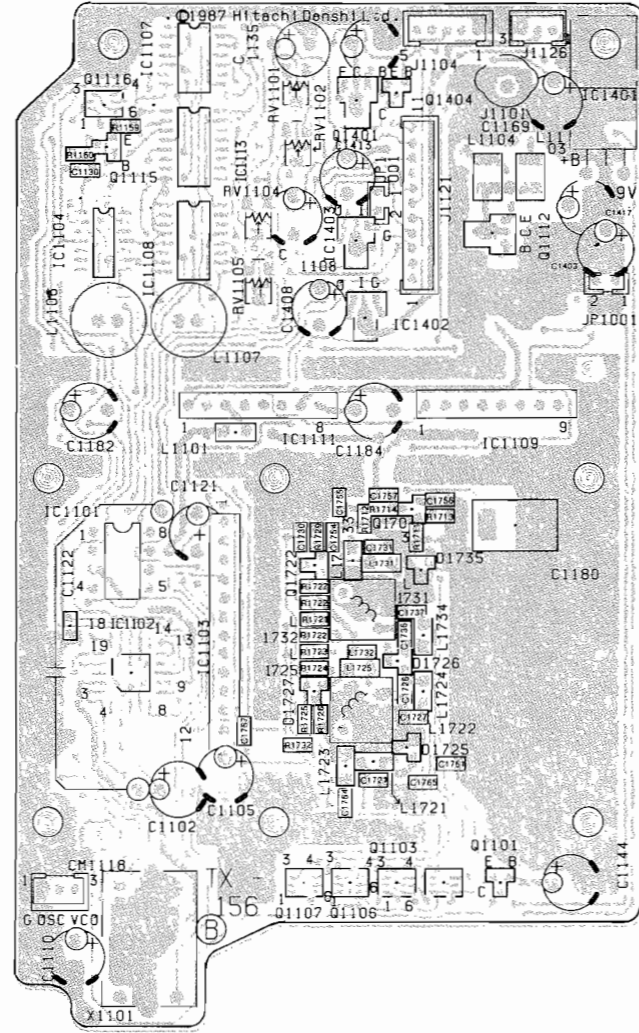
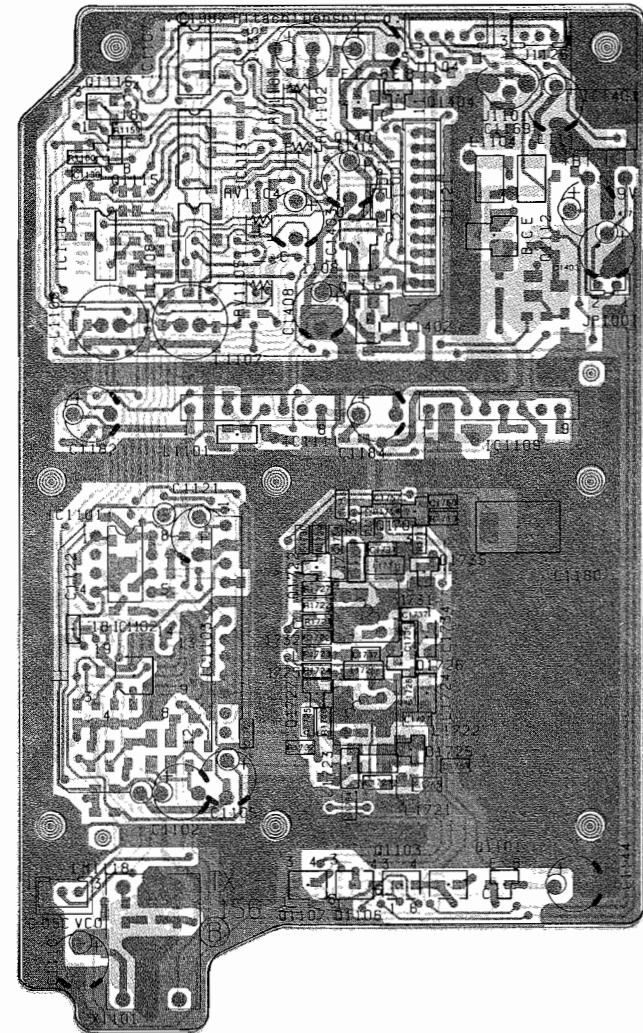

BOTTOM VIEW

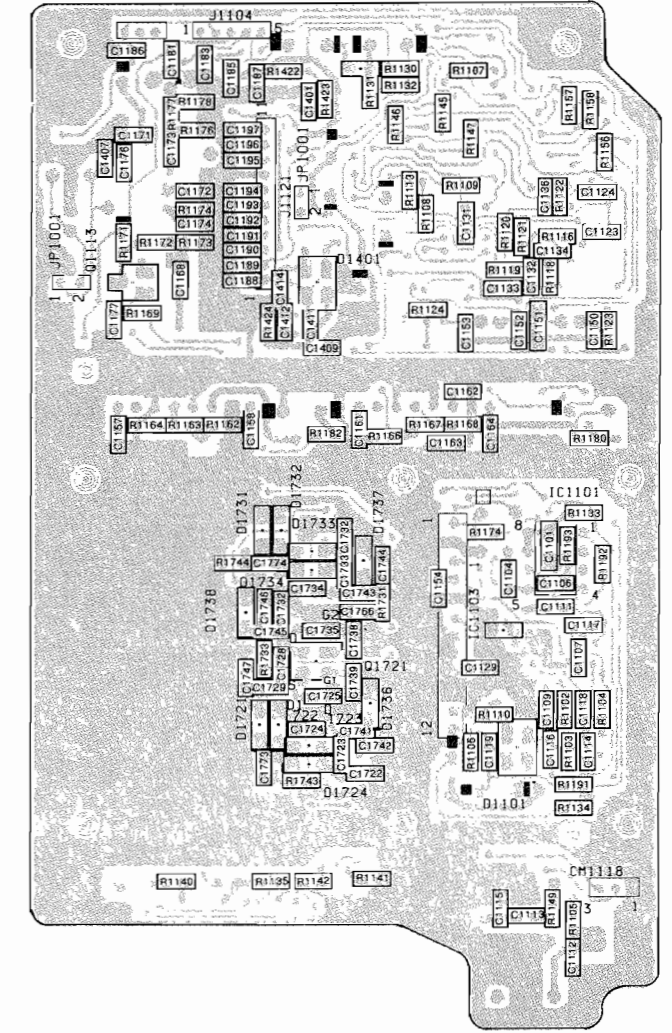
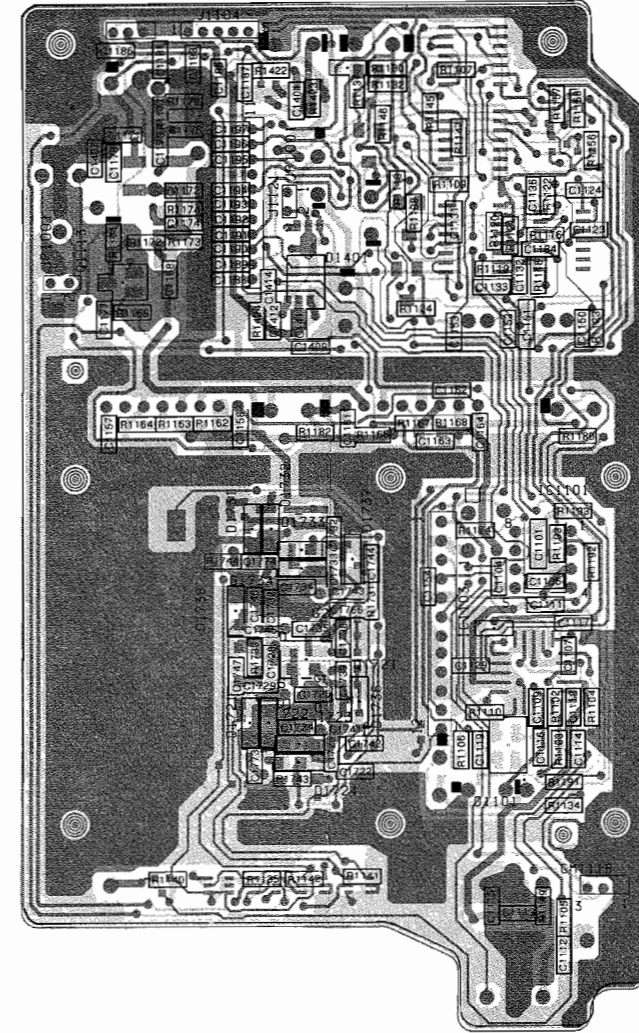

BLUE VISIBLE PLATING  
RED UNDERSIDE PLATING

1  
2  
3  
4  
5  
6  
7  
8

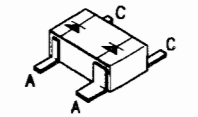
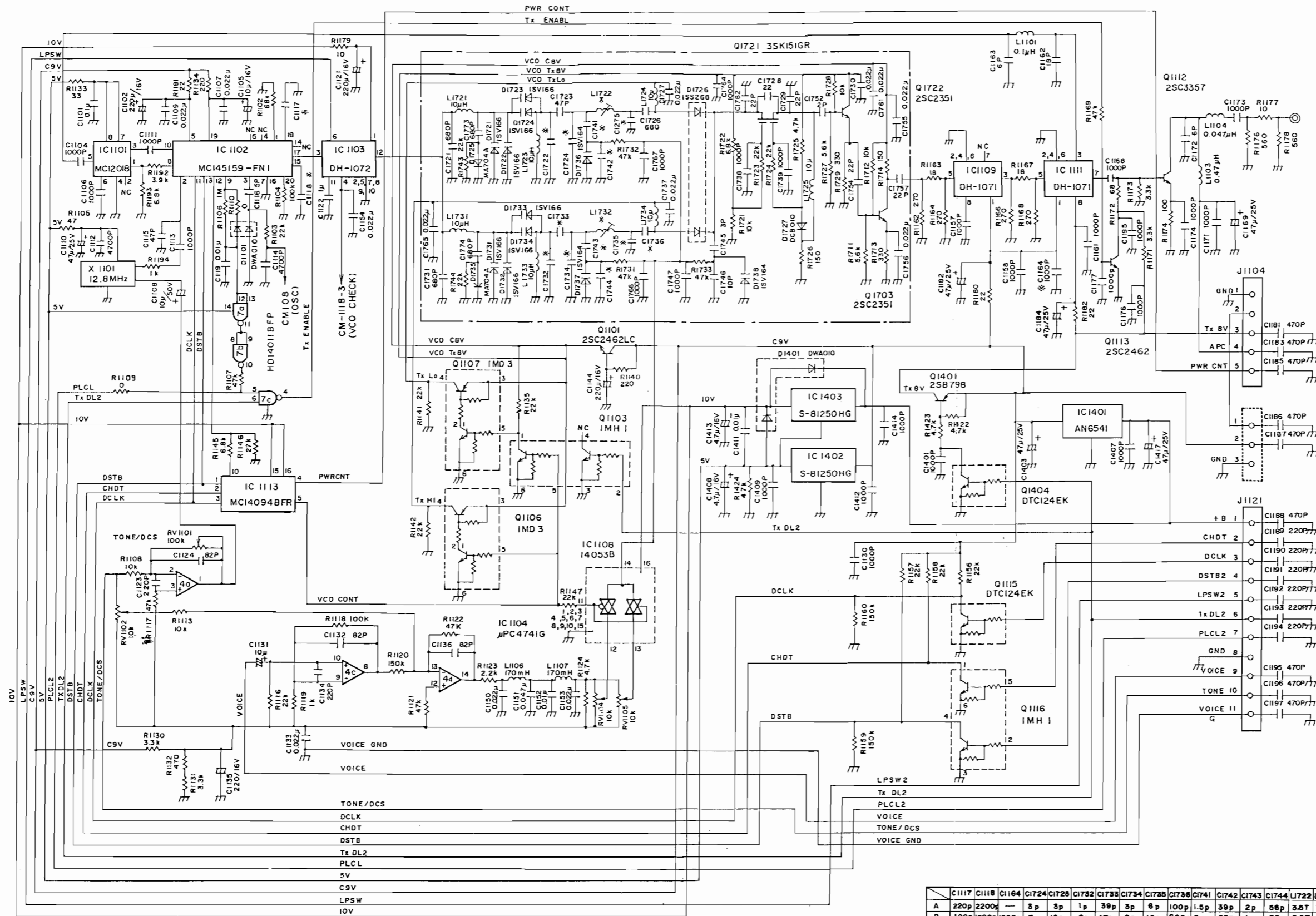

D1101, D1401

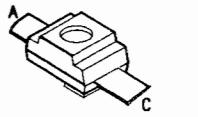

D1721, D1722, D1723, D1724, D1731, D1732, D1733, D1734, D1736, D1737, D1738

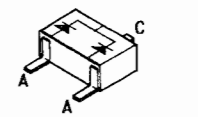

D1725, D1726, D1727, D1728

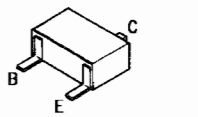

Q1101, Q1113, Q1115, Q1404, Q1703, Q1722

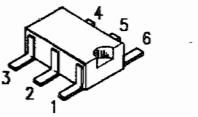

Q1102, Q1103, Q1106, Q1107, Q1116

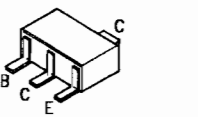

Q1401

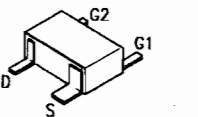

Q1721

	C1117	C1118	C1164	C1724	C1726	C1732	C1733	C1734	C1735	C1736	C1741	C1742	C1743	C1744	L1722	L1723
A	220p	2200p	—	3p	3p	1p	39p	3p	6p	100p	1.5p	39p	2p	56p	3.5T	3.5T
B	100p	1000p	1000p	7p	15p	2p	47p	8p	10p	680p	3p	68p	1p	39p	2.5T	2.5T

**BOTTOM VIEW**

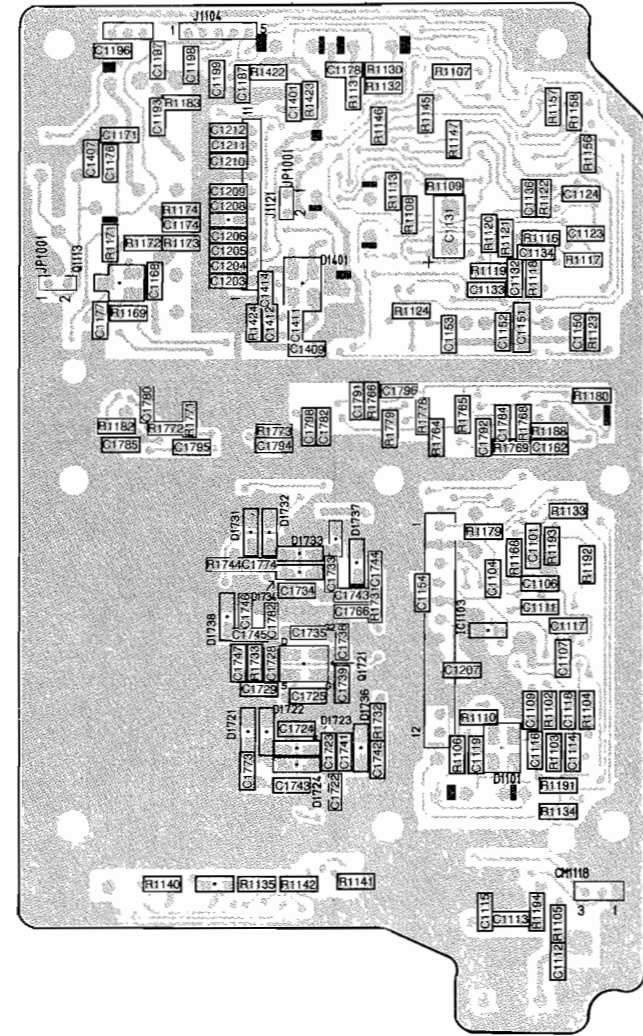
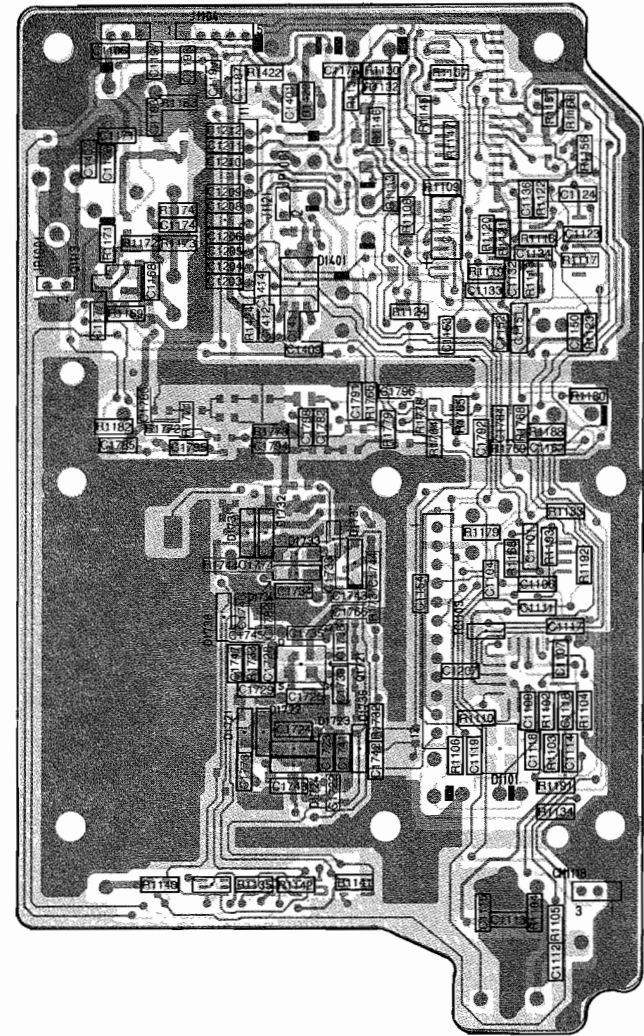

**TOP VIEW**

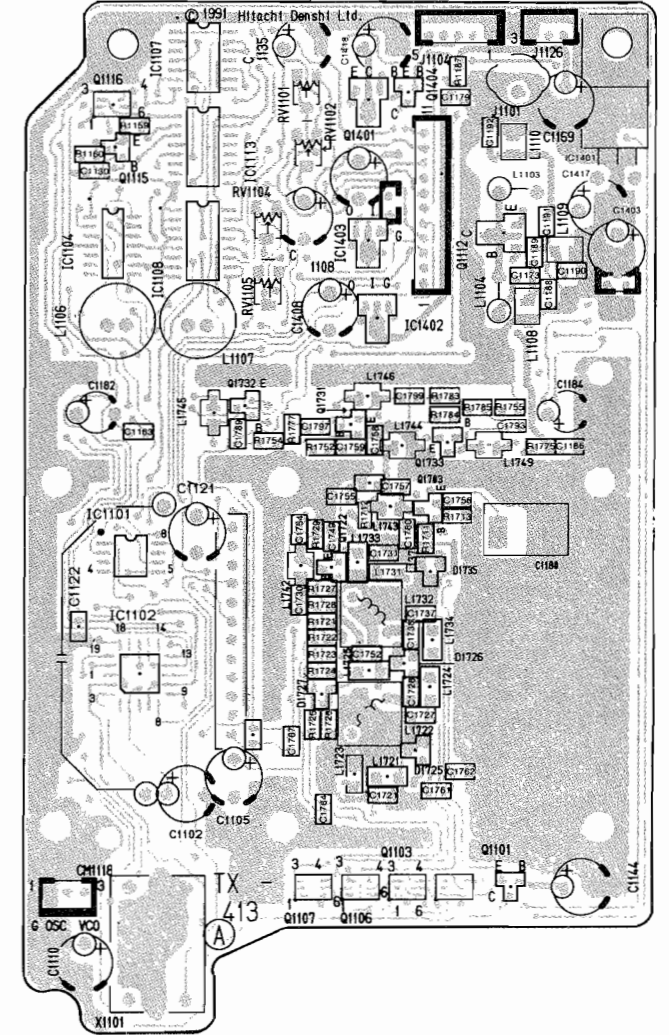
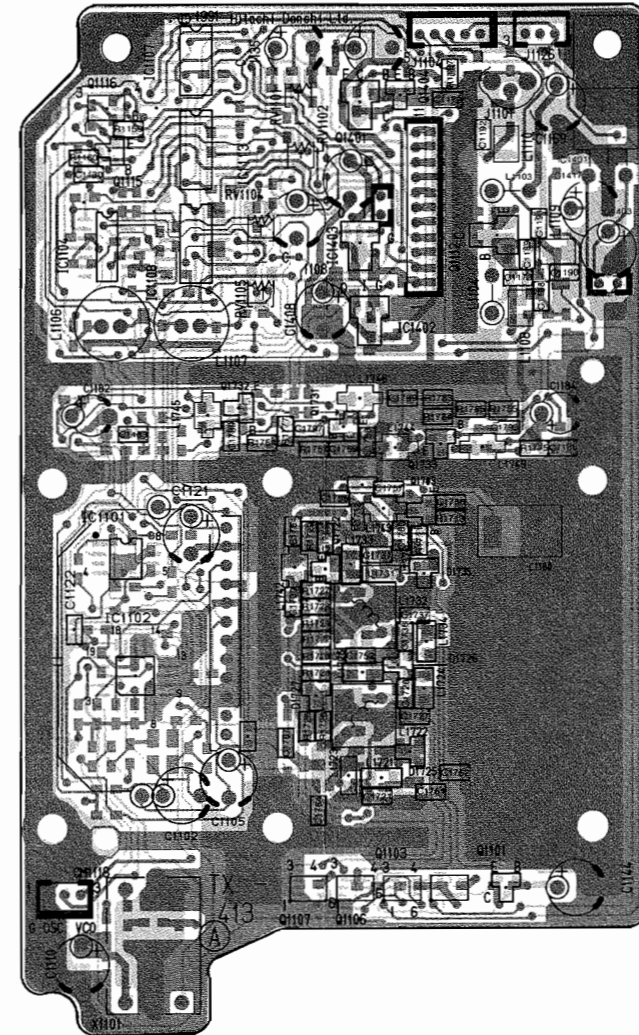

**BLUE** VISIBLE PLATING  
**RED** UNDERSIDE PLATING

# 70-5300AD/BD TX EXCITER SCHEMATIC

70-3400AD/BD—70-5300AD/BD

1  
2  
3  
4  
5  
6  
7  
8

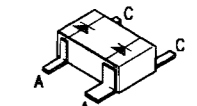
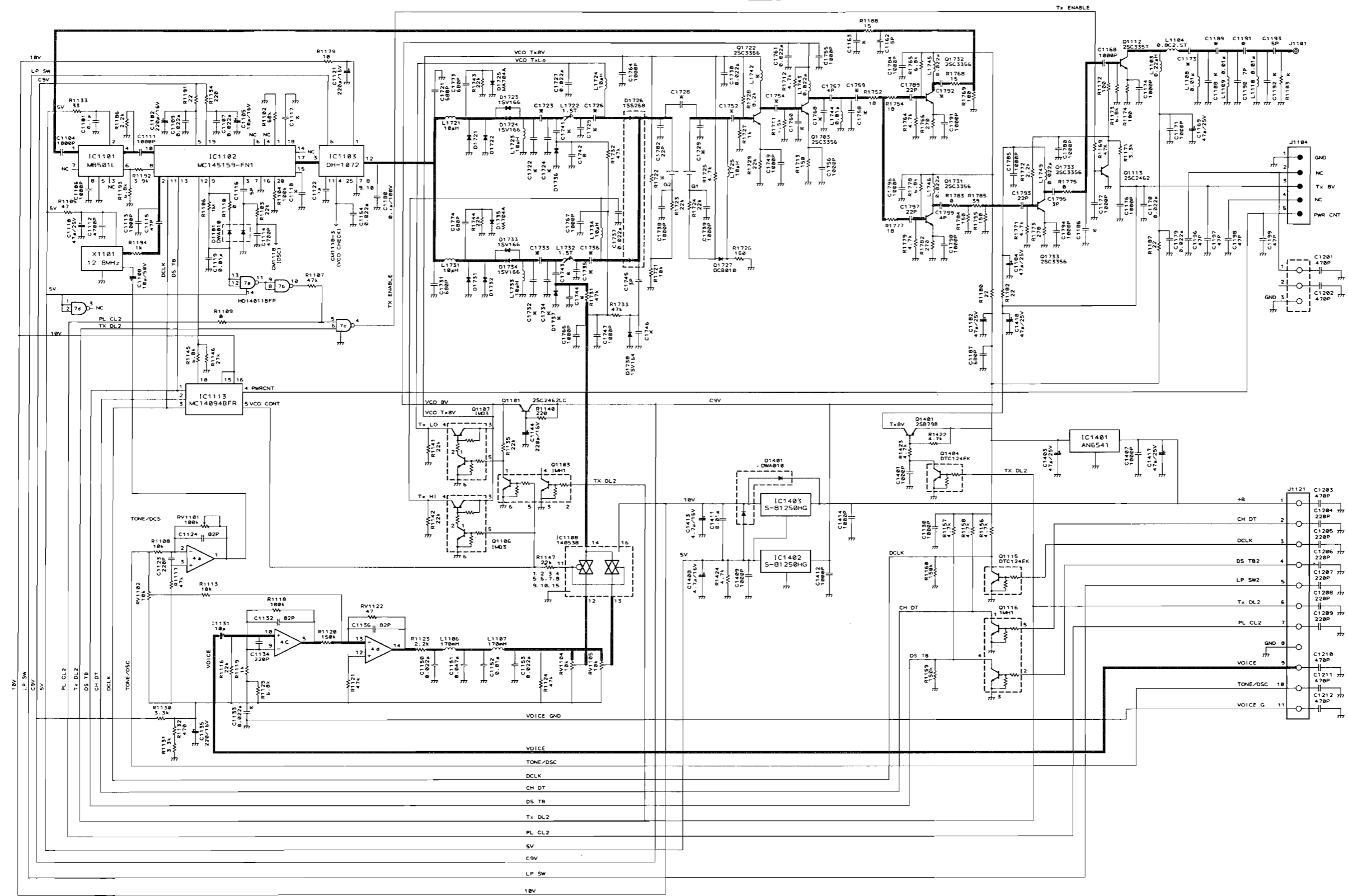

D1101, D1401

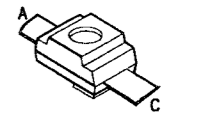

D1721, D1722, D1723, D1724,  
D1731, D1732, D1733, D1734,  
D1736, D1737, D1738

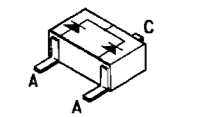

D1725, D1726, D1727, D1735

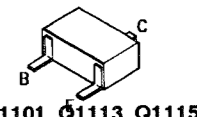

Q1101, Q1113, Q1115,  
Q1404, Q1703, Q1722,  
Q173, Q1732, Q1733

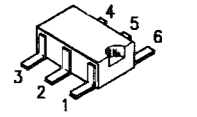

Q1103, Q1106, Q1107, Q1116,

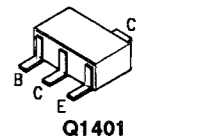

Q1401

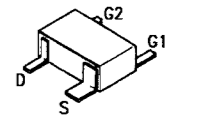

Q1721

BAND	R1722	C1173	C1186	C1188	C1189	C1198	C1191	C1192	D1737	C1117	C1118	C1722	C1723	C1724	C1725	C1126	C1732	C1733	C1734	C1735	C1736	C1741	C1742	C1743	C1744	C1746	C1760	C1728	C1729	C1752	C1754	C1758	C1759	C1768	C1792	C1163	R1183	L1742	C1133	
A	22k	12p	—	7p	3p	8p	5p	7p	—	100p	1000p	4p	33p	22p	10p	600p	5p	33p	27p	5p	600p	1p	33p	—	—	22p	—	22p	22p	3p	7p	10p	5p	5p	5p	6p	7p	150	0.01u	OPTION
B	5.8k	7p	8p	7p	2p	7p	5p	7p	15V164	100p	1000p	3p	22p	15p	5p	800p	—	10p	10p	—	600p	1p	47p	1p	100p	22p	10p	22p	22p	3p	5p	5p	4p	—	4p	10p	150	0.022u	OPTION	

# 70-3400AD/BD EXPLODED VIEW

70-3400AD/BD—70-5300AD/BD

**B C D E F G H I J K L M**

**1**  
**2**  
**3**  
**4**  
**5**  
**6**  
**7**  
**8**

REF NO	DESCRIPTION	PART NO.
4	TOP COVER	70-010190
6	PORT COVER	70-010192
7	SIDE RAIL	70-010193
23	PA COVER	70-089320
25	PA INSULATOR	70-010270
26	GROUND CABLE	70-034329
250	DUPLEXER	70-D02
251	COVER	70-010394
252	BOTTOM PLATE	70-013048
253	BRACKET	70-158421
254	HOLE PLUG	70-157723
255	PA HEAT SINK	70-089421
256	CONNECTOR COVER	70-010395
257	PCB RADIATOR	70-089422
258	CABLE HOLDER	70-158422
260	VCO CASE	70-089420
261	RUBBER	70-157271
262	T/M BRACKET	70-158423
263	SNAP LOCK	70-158424
264	SPACER	70-156151
504	SCREW BIND HD M3 X 8 FE NIP	70-151356
505	SCREW BIND HD M3 X 8 FE DNIP	70-151409
506	SCREW M3 X 12	70-151839
508	SCREW SEMS PAN HD M3 X 10 FE NIP	70-151273
509	SCREW SEMS PAN HD M3 X 14 FE NIP	70-150451
525	SCREW BIND HD M3 X 16 SUS DNIP	70-150452
526	SCREW TAPPING M6 X 20	70-150453
J1101	BNC — UHF PANEL ADAPTER	70-159799

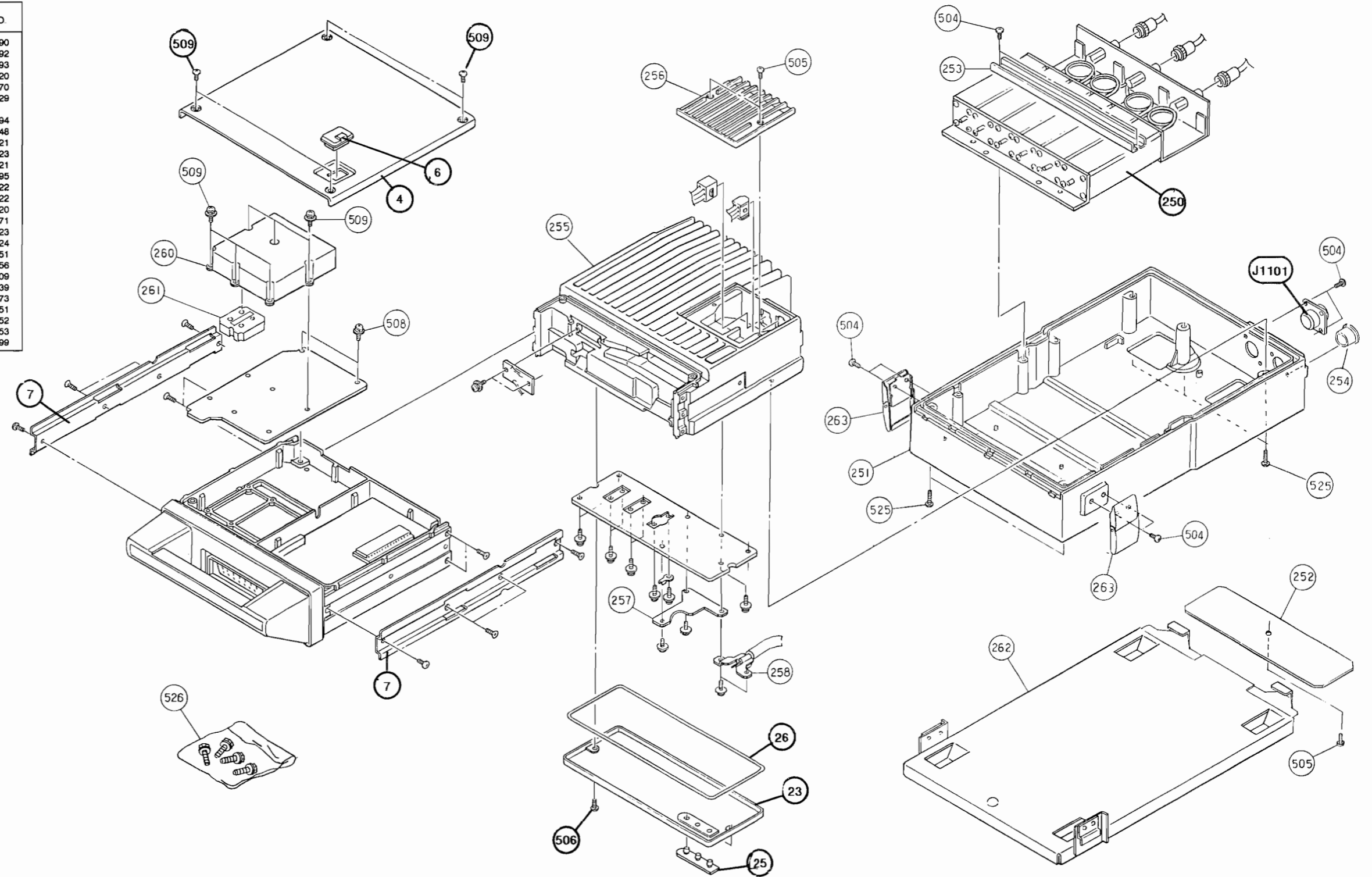

A B C D E F G H I J K L

1  
2  
3  
4  
5  
6  
7  
8

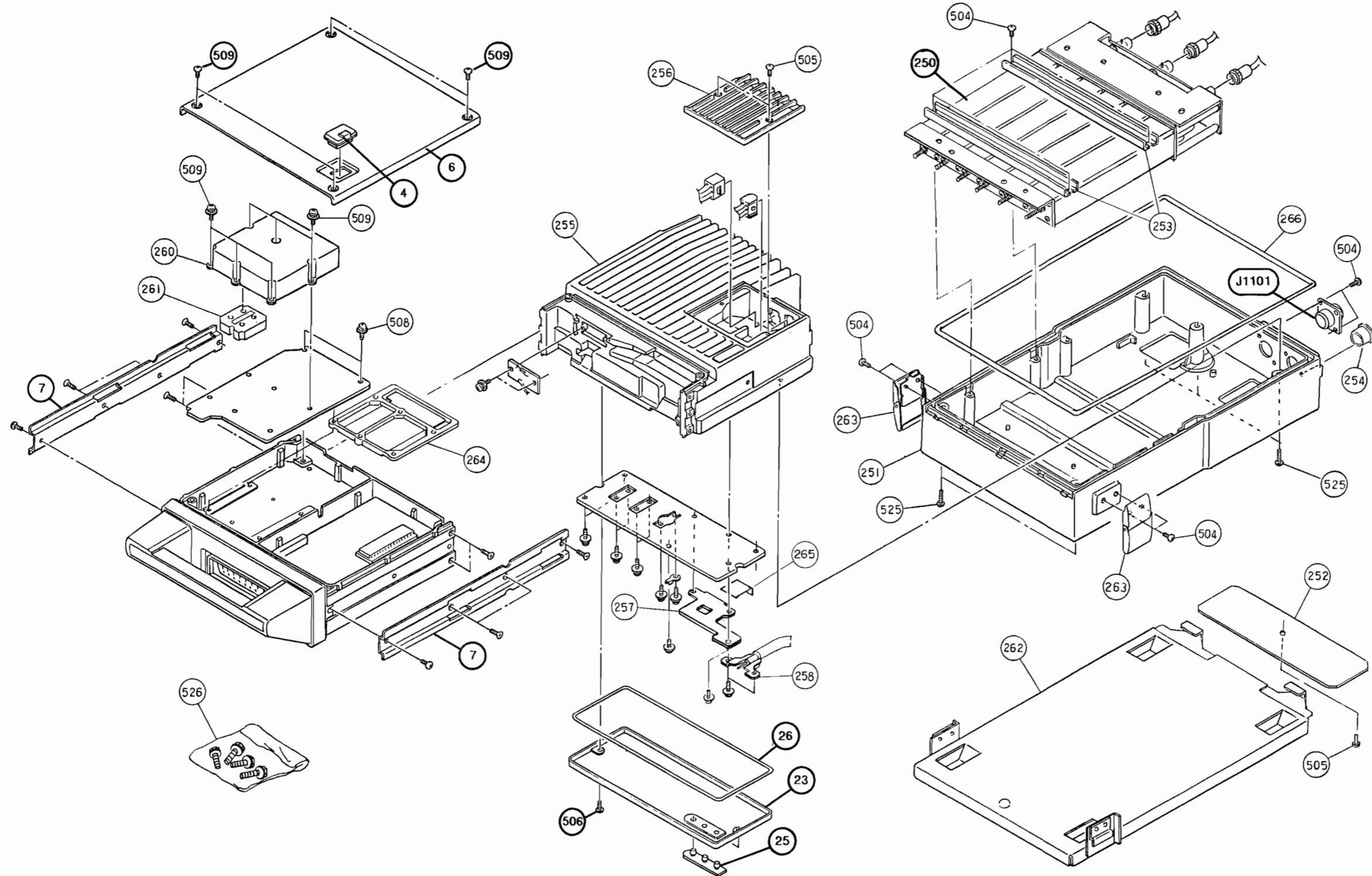

REF NO.	DESCRIPTION	PART NO.
4	TOP COVER	70-010180
6	PORT COVER	70-010182
7	SIDE RAIL	70-010183
23	PA COVER	70-089320
25	PA INSULATOR	70-010270
26	GROUND CABLE	70-034329
250	DUPLEXER	70-D03
251	COVER	70-010394
252	BOTTOM PLATE	70-013048
253	BRACKET	70-158421
254	HOLE PLUG	70-157723
255	PA HEAT SINK	70-089421
256	CONNECTOR COVER	70-010395
257	PCB RADIATOR	70-089426
258	CABLE HOLDER	70-158426
260	VCO CASE	70-089420
261	RUBBER	70-157271
262	T/M BRACKET	70-158423
263	SNAP LOCK	70-158424
264	SPACER	70-156151
265	THERMAL SHEET	70-157736
266	SHIELD TUBE	70-034908
504	SCREW BIND HD M3 X 8 FE NIP	70-151356
505	SCREW BIND HD M3 X 8 FE DNIP	70-151409
506	SCREW M3 X 12	70-151839
508	SCREW SEMS PAN HD M3 X 10 FE NIP	70-151273
509	SCREW SEMS PAN HD M3 X 14 FE NIP	70-150451
525	SCREW BIND HD M3 X 16 SUS DNIP	70-150452
526	SCREW TAPPING M6 X 20	70-150453
J1101	BNC — UHF PANEL ADAPTER	70-159789



**DIAGRAMS**

70-3400AD/BD—70-5300AD/BD

<b>B</b>	<b>C</b>	<b>D</b>	<b>E</b>	<b>F</b>	<b>G</b>	<b>H</b>	<b>I</b>	<b>J</b>	<b>K</b>	<b>L</b>	<b>M</b>
----------	----------	----------	----------	----------	----------	----------	----------	----------	----------	----------	----------

1

NOTES

2

3

4

5

6

7

8

**SECTION 6**

---

**PARTS**

# PARTS

---

70-3400AD/BD—70-5300AD/BD

## NOTES

## MECHANICAL PARTS

V = VHF (3400AD/BD) ONLY      U = UHF (5300AD/BD) ONLY		
REF NO.	DESCRIPTION	PART NO.
250 V	DUPLEXER	70-D02
250 U	DUPLEXER	70-D03
251	COVER	70-010394
252	BOTTOM PLATE	70-013048
253	BRACKET	70-158421
254	HOLE PLUG	70-157723
255	PA HEAT SINK	70-089421
256	CONNECTOR COVER	70-010395
257 V	PCB RADIATOR	70-089422
257 U	PCB RADIATOR	70-089426
258 V	CABLE HOLDER	70-158422
258 U	CABLE HOLDER	70-158426
260	VCO CASE	70-089420
261	RUBBER	70-157271
262	T/M BRACKET	70-158423
263	SNAP LOCK	70-158424
264	SPACER	70-156151
265 U	THERMAL SHEET	70-157736
266 U	SHIELD TUBE	70-034908
504	SCREW BIND HD M3 X 8 FE NIP	70-151356
505	SCREW BIND HD M3 X 8 FE DNIP	70-151409
508	SCREW SEMS PAN HD M3 X 10 FE NIP	70-151273
509	SCREW SEMS PAN HD M3 X 14 FE NIP	70-150451
525	SCREW BIND HD M3 X 16 SUS DNIP	70-150452
526	SCREW TAPPING M6 X 20	70-150453

## 70-3400AD/BD ELECTRICAL PARTS (TX-156)

A = A-Band Only    B = B-Band Only    U = PCB Underside    T = PCB Topside							
REF NO.	LOC	DESCRIPTION	PART NO.	REF NO.	LOC	DESCRIPTION	PART NO.
CAPACITORS				CAPACITORS (Continued)			
C1101	U	0.1 $\mu$ F, 50 V, CERAMIC	70-133117	C1164 B	U	1000 pF, 50 V, CERAMIC	70-138170
C1102	T	220 $\mu$ F, 16 V, AL ELYC	70-135164	C1168	U	1000 pF, 50 V, CERAMIC	70-138170
C1104	U	1000 pF, 50 V, CERAMIC	70-138170	C1169	T	47 $\mu$ F, 25 V, AL ELYC	70-135144
C1105	T	10 $\mu$ F, 16 V, AL ELYC	70-135163	C1171	U	1000 pF, 50 V, CERAMIC	70-138170
C1106	U	1000 pF, 50 V, CERAMIC	70-138170	C1172	U	6 pF, 50 V, CERAMIC	70-138348
C1107	U	0.022 $\mu$ F, 25 V, CERAMIC	70-138253	C1173	U	1000 pF, 50 V, CERAMIC	70-138170
C1108	T	10 $\mu$ F, 50 V, AL ELYC	70-135142	C1174	U	1000 pF, 50 V, CERAMIC	70-138170
C1109	U	0.022 $\mu$ F, 25 V, CERAMIC	70-138253	C1175	T	1000 pF, 50 V, CERAMIC	70-138170
C1110	T	47 $\mu$ F, 25 V, AL ELYC	70-135144	C1176	U	1000 pF, 50 V, CERAMIC	70-138170
C1111	U	1000 pF, 50 V, CERAMIC	70-138170	C1177	U	1000 pF, 50 V, CERAMIC	70-138170
C1112	U	4700 pF, 50 V, CERAMIC	70-138163	C1178	T	0.022 $\mu$ F, 25 V, CERAMIC	70-138253
C1113	U	1000 pF, 50 V, CERAMIC	70-138170	C1179	T	0.022 $\mu$ F, 25 V, CERAMIC	70-138253
C1114	U	4700 pF, 50 V, CERAMIC	70-138163	C1180	T	0.1 $\mu$ F, 100 V, PLASTIC	70-137086
C1115	U	47 pF, 50 V, CERAMIC	70-138185	C1182	T	47 $\mu$ F, 25 V, AL ELYC	70-135144
C1116	U	5 pF, 50 V, CERAMIC	70-138160	C1183	U	470 pF, 50 V, CERAMIC	70-138195
C1117 A	U	220 pF, 50 V, CERAMIC	70-138349	C1184	T	47 $\mu$ F, 25 V, AL ELYC	70-135144
C1117 B	U	100 pF, 50 V, CERAMIC	70-138175	C1185	U	470 pF, 50 V, CERAMIC	70-138195
C1118 A	U	2200 pF, 50 V, CERAMIC	70-138235	C1187	U	470 pF, 50 V, CERAMIC	70-138195
C1118 B	U	1000 pF, 50 V, CERAMIC	70-138170	C1188	U	470 pF, 50 V, CERAMIC	70-138195
C1119	U	0.01 pF, 50 V, CERAMIC	70-138270	C1189	U	220 pF, 50 V, CERAMIC	70-138349
C1121	T	220 $\mu$ F, 16 V, AL ELYC	70-135164	C1190	U	220 pF, 50 V, CERAMIC	70-138349
C1122	T	1 $\mu$ F, 200 V, PLASTIC	70-137081	C1191	U	220 pF, 50 V, CERAMIC	70-138349
C1123	T	220 pF, 50 V, CERAMIC	70-138349	C1192	U	220 pF, 50 V, CERAMIC	70-138349
C1124	U	82 pF, 50 V, CERAMIC	70-138250	C1193	U	220 pF, 50 V, CERAMIC	70-138349
C1130	T	1000 pF, 50 V, CERAMIC	70-138170	C1194	U	220 pF, 50 V, CERAMIC	70-138349
C1131	U	10 $\mu$ F, 16 V, TA ELYC	70-135090	C1195	U	470 pF, 50 V, CERAMIC	70-138195
C1132	U	82 pF, 50 V, CERAMIC	70-138250	C1196	U	470 pF, 50 V, CERAMIC	70-138195
C1133	U	0.022 $\mu$ F, 25 V, CERAMIC	70-138253	C1197	U	470 pF, 50 V, CERAMIC	70-138195
C1134	U	220 pF, 50 V, CERAMIC	70-138349	C1401	U	1000 pF, 50 V, CERAMIC	70-138170
C1135	T	220 $\mu$ F, 16 V, AL ELYC	70-135164	C1401	U	1000 pF, 50 V, CERAMIC	70-138170
C1136	U	82 pF, 50 V, CERAMIC	70-138250	C1403	T	4.7 $\mu$ F, 25 V, AL ELYC	70-135144
C1144	T	220 $\mu$ F, 16 V, AL ELYC	70-135164	C1403	T	47 $\mu$ F, 25 V, AL ELYC	70-135144
C1150	U	0.022 $\mu$ F, 25 V, CERAMIC	70-138253	C1407	U	1000 pF, 50 V, CERAMIC	70-138170
C1151	U	0.047 $\mu$ F, 50 V, CERAMIC	70-131298	C1408	U	4.7 $\mu$ F, 16 V, AL ELYC	70-135172
C1152	U	0.01 $\mu$ F, 50 V, CERAMIC	70-138270	C1409	U	1000 pF, 50 V, CERAMIC	70-138170
C1153	U	0.022 $\mu$ F, 25 V, CERAMIC	70-138253	C1409	U	1000 pF, 50 V, CERAMIC	70-138170
C1154	U	0.022 $\mu$ F, 25 V, CERAMIC	70-138253	C1411	U	0.01 $\mu$ F, 50 V, CERAMIC	70-138270
C1157	T	1000 pF, 50 V, CERAMIC	70-138170	C1411	U	0.01 $\mu$ F, 50 V, CERAMIC	70-138270
C1158	U	1000 pF, 50 V, CERAMIC	70-138170	C1412	U	1000 pF, 50 V, CERAMIC	70-138170
C1161	U	1000 pF, 50 V, CERAMIC	70-138170	C1412	U	1000 pF, 50 V, CERAMIC	70-138170
C1162	U	18 pF, 50 V, CERAMIC	70-138206	C1413	U	4.7 $\mu$ F, 16 V, AL ELYC	70-135172
C1163	U	6 pF, 50 V, CERAMIC	70-138348	C1414	U	1000 pF, 50 V, CERAMIC	70-138170

**PARTS**

70-3400AD/BD—70-5300AD/BD

**70-3400AD/BD ELECTRICAL PARTS (TX-156)— Continued**

REF NO.	LOC	DESCRIPTION	PART NO.	REF NO.	LOC	DESCRIPTION	PART NO.
CAPACITORS (Continued)				INTEGRATED CIRCUITS (Continued)			
C1414	U	1000 pF, 50 V, CERAMIC	70-138170	IC1107	T	HD14011BFP/MC14011BFP	70-076506
C1417	U	47 μF, 25 V, AL ELYC	70-135144	IC1108	T	HD14053BFP/MC14053BFP	70-076465
C1721	T	680 pF, 50 V, CERAMIC	70-138252	IC1109	T	DH-1071A	70-076466
C1722 A	U	1 pF, 50 V, CERAMIC	70-138174	IC1111	T	DH-1071A	70-076466
C1723	U	47 pF, 50 V, CERAMIC	70-138185	IC1113	T	MC1409BF	70-076467
C1724 A	U	3 pF, 50 V, CERAMIC	70-138460	IC1401	T	AN6541	70-076253
C1724 B	U	7 pF, 50 V, CERAMIC	70-138181	IC1402	T	S-81250HG	70-076753
C1725 A	U	3 pF, 50 V, CERAMIC	70-138460	IC1403	T	S-81250HG	70-076753
C1725 B	U	15 pF, 50 V, CERAMIC	70-138205	TRANSISTORS			
C1726	T	680 pF, 50 V, CERAMIC	70-138252	Q1101	T	2SC2462LC	70-080294
C1727	T	0.022 μF, 25 V, CERAMIC	70-138253	Q1102	T	IMB4	70-080295
C1728	U	22 pF, 50 V, CERAMIC	70-138171	Q1103	T	IMH1	70-080296
C1729	U	22 pF, 50 V, CERAMIC	70-138171	Q1106	T	IMD3	70-080297
C1730	T	0.022 μF, 25 V, CERAMIC	70-138253	Q1107	T	IMD3	70-080297
C1731	U	680 pF, 50 V, CERAMIC	70-138252	Q1112	T	2SC3357-T2	70-080298
C1732 A	U	1 pF, 50 V, CERAMIC	70-138174	Q1113	U	2SC2462LC	70-080294
C1732 B	U	2 pF, 50 V, CERAMIC	70-138169	Q1115	T	DTC124K	70-080300
C1733 A	U	39 pF, 50 V, CERAMIC	70-138233	Q1116	T	IMH1	70-080296
C1733 B	U	47 pF, 50 V, CERAMIC	70-138185	Q1401	T	2SB798	70-080164
C1734 A	U	3 pF, 50 V, CERAMIC	70-138460	Q1404	T	DTC124EK	70-080300
C1734 B	U	8 pF, 50 V, CERAMIC	70-138203	Q1703	T	2SC2351	70-080218
C1735 A	U	6 pF, 50 V, CERAMIC	70-138348	Q1721	U	3SK151GR	70-080303
C1735 B	U	10 pF, 50 V, CERAMIC	70-138187	Q1722	T	2SC2351	70-080218
C1736 A	T	100 pF, 50 V, CERAMIC	70-138175	RESISTORS			
C1736 B	T	680 pF, 50 V, CERAMIC	70-138252	R1102	U	68 kΩ, 1/10 W, METAL	70-144119
C1737	T	0.022 μF, 25 V, CERAMIC	70-138253	R1103	U	22 kΩ, 1/10 W, METAL	70-144121
C1738	U	1000 pF, 50 V, CERAMIC	70-138170	R1104	U	100 kΩ, 1/10 W, METAL	70-144321
C1739	U	1000 pF, 50 V, CERAMIC	70-138170	R1105	U	47 kΩ, 1/10 W, METAL	70-145130
C1741 A	U	1.5 pF, 50 V, CERAMIC	70-138180	R1106	U	1 MΩ, 1/10 W, METAL	70-144155
C1741 B	U	3 pF, 50 V, CERAMIC	70-138460	R1107	U	47 kΩ, 1/10 W, METAL	70-144231
C1742 A	U	39 pF, 50 V, CERAMIC	70-138233	R1108	U	10 kΩ, 1/10 W, METAL	70-144120
C1742 B	U	68 pF, 50 V, CERAMIC	70-138229	R1109	T	0 Ω, 1/10 W, METAL	70-144106
C1743 A	U	2 pF, 50 V, CERAMIC	70-138169	R1110	U	0 Ω, 1/10 W, METAL	70-144106
C1743 B	U	1 pF, 50 V, CERAMIC	70-138174	R1113	U	10 kΩ, 1/10 W, METAL	70-144120
C1744 A	U	56 pF, 50 V, CERAMIC	70-138254	R1116	U	22 kΩ, 1/10 W, METAL	70-144121
C1744 B	U	39 pF, 50 V, CERAMIC	70-138233	R1117	U	47 kΩ, 1/10 W, METAL	70-141210
C1745	U	3 pF, 50 V, CERAMIC	70-138460	R1118	U	100 kΩ, 1/10 W, METAL	70-144321
C1746	U	10 pF, 50 V, CERAMIC	70-138187	R1119	U	1 kΩ, 1/10 W, METAL	70-144125
C1747	U	1000 pF, 50 V, CERAMIC	70-138170	R1120	U	150 kΩ, 1/10 W, METAL	70-144129
C1752	T	2 pF, 50 V, CERAMIC	70-138169	R1121	U	47 kΩ, 1/10 W, METAL	70-144231
C1754	T	22 pF, 50 V, CERAMIC	70-138171	R1122	U	47 kΩ, 1/10 W, METAL	70-144231
C1755	T	0.022 μF, 25 V, CERAMIC	70-138253	R1123	U	2.2 kΩ, 1/10 W, METAL	70-144113
C1756	T	0.022 μF, 25 V, CERAMIC	70-138253	R1124	U	4.7 kΩ, 1/10 W, METAL	70-144123
C1757	T	22 pF, 50 V, CERAMIC	70-138171	R1130	U	33 kΩ, 1/10 W, METAL	70-144112
C1761	T	0.022 μF, 25 V, CERAMIC	70-138253	R1131	U	33 kΩ, 1/10 W, METAL	70-144112
C1764	T	1000 pF, 50 V, CERAMIC	70-138170	R1132	U	4.7 kΩ, 1/10 W, METAL	70-144123
C1765	T	0.022 μF, 25 V, CERAMIC	70-138253	R1133	U	33 Ω, 1/10 W, METAL	70-140320
C1766	U	1000 pF, 50 V, CERAMIC	70-138170	R1134	U	220 Ω, 1/10 W, METAL	70-144194
C1767	T	1000 pF, 50 V, CERAMIC	70-138170	R1135	U	22 kΩ, 1/10 W, METAL	70-144121
C1773	U	690 pF, 50 V, CERAMIC	70-138252	R1136	U	47 kΩ, 1/10 W, METAL	70-144231
C1774	U	690 pF, 50 V, CERAMIC	70-138252	R1140	U	220 Ω, 1/10 W, METAL	70-144194
C1782	U	22 pF, 50 V, CERAMIC	70-138171	R1141	U	22 kΩ, 1/10 W, METAL	70-144121
DIODES				R1142	U	22 kΩ, 1/10 W, METAL	70-144121
D1101	T	DWA010-TF	70-085246	R1145	U	6.8 kΩ, 1/10 W, METAL	70-144158
D1401	U	DWA010-TF	70-085246	R1146	U	27 kΩ, 1/10 W, METAL	70-144163
D1721	U	1SV166	70-085159	R1147	U	22 kΩ, 1/10 W, METAL	70-144121
D1722	U	1SV166	70-085159	R1156	U	22 kΩ, 1/10 W, METAL	70-144121
D1723	U	1SV166	70-085159	R1157	U	22 kΩ, 1/10 W, METAL	70-144121
D1724	U	1SV166	70-085159	R1158	U	22 kΩ, 1/10 W, METAL	70-144121
D1725	T	MA704A	70-085247	R1159	U	150 kΩ, 1/10 W, METAL	70-144129
D1726	T	1SS268	70-085248	R1160	U	150 kΩ, 1/10 W, METAL	70-144129
D1727	T	DCB010	70-085245	R1162	U	270 Ω, 1/10 W, METAL	70-144116
D1731	U	1SV166	70-085159	R1163	U	18 Ω, 1/10 W, METAL	70-144171
D1732	U	1SV166	70-085159	R1164	U	270 Ω, 1/10 W, METAL	70-144116
D1733	U	1SV166	70-085159	R1166	U	270 Ω, 1/10 W, METAL	70-144116
D1734	U	1SV166	70-085159	R1167	U	18 Ω, 1/10 W, METAL	70-144171
D1735	T	MA704A	70-085247	R1168	U	270 kΩ, 1/10 W, METAL	70-144116
D1736	U	1SV164	70-085191	R1169	U	47 kΩ, 1/10 W, METAL	70-144231
D1737	U	1SV164	70-085191	R1171	U	3.3 kΩ, 1/10 W, METAL	70-144118
D1738	U	1SV164	70-085191	R1172	U	68 Ω, 1/10 W, METAL	70-144114
INTEGRATED CIRCUITS				R1173	U	3.3 kΩ, 1/10 W, METAL	70-144118
IC1101	T	MC12018P	70-076460	R1174	U	100 Ω, 1/10 W, METAL	70-144136
IC1102	T	MC145159FN1	70-076461	R1176	U	580 Ω, 1/10 W, METAL	70-144130
IC1103	T	DH1072A	70-076462				
IC1104	T	MPC4741G	70-076628				

## 70-3400AD/BD ELECTRICAL PARTS (TX-156)— Continued

REF NO.	LOC	DESCRIPTION	PART NO.	REF NO.	LOC	DESCRIPTION	PART NO.
RESISTORS (Continued)				VARIABLE RESISTORS			
R1177	U	10 Ω, 1/10 W, METAL	70-144115	RV1101	T	100 kΩ	70-164093
R1178	U	560 Ω, 1/10 W, METAL	70-144130	RV1102	T	10 kΩ	70-164094
R1179	U	10 Ω, 1/10 W, METAL	70-144115	RV1104	T	10 kΩ	70-164094
R1180	U	22 Ω, 1/10 W, METAL	70-144160	RV1105	T	10 kΩ	70-164094
R1182	U	22 Ω, 1/10 W, METAL	70-144160	JACKS AND CONNECTORS			
R1191	U	22 Ω, 1/10 W, METAL	70-144160	CM1118	T	IL-S-3P-S2T2-EF	70-159254
R1192	U	3.9 kΩ, 1/10 W, METAL	70-145132	J1101	T	BNC - UHF PANEL ADAPTER	70-159799
R1193	U	6.8 kΩ, 1/10 W, METAL	70-144158	J1104	T	IL-S-5P-S2T2-EF	70-159424
R1194	U	1.0 kΩ, 1/10 W, METAL	70-144125	COILS AND CONDUCTORS			
R1422	U	4.7 kΩ, 1/10 W, METAL	70-144123	L1101	T	MLF321606DR10KL	70-090648
R1423	U	4.7 kΩ, 1/10 W, METAL	70-144123	L1103	T	MLF3216DR47KL	70-090318
R1424	U	4.7 kΩ, 1/10 W, METAL	70-144123	L1104	T	MLF3216DR47KL	70-178055
R1711	T	5.6 kΩ, 1/10 W, METAL	70-144168	L1106	T	FS1012S-174K	70-178055
R1712	T	10 kΩ, 1/10 W, METAL	70-144120	L1107	T	FS1012S-174K	70-178055
R1713	T	330 kΩ, 1/10 W, METAL	70-144164	L1721	T	MLF321611E 100M	70-090324
R1714	T	150 kΩ, 1/10 W, METAL	70-144321	L1722 A	T	MC122 3 5T	70-090235
R1721	T	10 kΩ, 1/10 W, METAL	70-144120	L1722 B	T	MC122 2 5T	70-090315
R1722	T	6.8 kΩ, 1/10 W, METAL	70-144158	L1723	T	MLF321611E 100M	70-090324
R1723	T	22 kΩ, 1/10 W, METAL	70-144121	L1724	T	MLF321611E 100M	70-090324
R1724	T	22 kΩ, 1/10 W, METAL	70-144121	L1725	T	MLF321611E 100M	70-090324
R1725	T	4.7 kΩ, 1/10 W, METAL	70-144123	L1731	T	MLF321611E 100M	70-090324
R1726	T	150 Ω, 1/10 W, METAL	70-144321	L1732 A	T	MC122 3 5T	70-090235
R1727	T	5.6 kΩ, 1/10 W, METAL	70-144168	L1732 B	T	MC122 2 5T	70-090315
R1728	T	10 kΩ, 1/10 W, METAL	70-144120	L1733	T	MLF321611E 100M	70-090324
R1729	T	330 Ω, 1/10 W, METAL	70-144164	L1734	T	MLF321611E 100M	70-090324
R1731	U	47 kΩ, 1/10 W, METAL	70-144231	MISCELLANEOUS			
R1732	T	47 kΩ, 1/10 W, METAL	70-144231	X1101	T	12.8 MHz CRYSTAL	70-128080
R1733	U	47 kΩ, 1/10 W, METAL	70-144231				
R1743	U	22 kΩ, 1/10 W, METAL	70-144121				
R1744	U	22 kΩ, 1/10 W, METAL	70-144121				

## 70-5300AD/BD ELECTRICAL PARTS (TX-413)

A = A-Band Only		B = B-Band Only		U = PCB Underside		T = PCB Topside	
REF NO.	LOC	DESCRIPTION	PART NO.	REF NO.	LOC	DESCRIPTION	PART NO.
CAPACITORS				CAPACITORS (Continued)			
C1101	U	0.1 μF, 50 V, CERAMIC	70-133117	C1153	U	0.022 μF, 25 V, CERAMIC	70-138253
C1102	T	220 μF, 16 V, AL ELYC	70-135164	C1154	U	0.022 μF, 25 V, CERAMIC	70-138253
C1104	U	1000 pF, 50 V, CERAMIC	70-138170	C1162 B	U	10 pF, 50 V, CERAMIC	70-138187
C1105	T	10 μF, 50 V, AL ELYC	70-135142	C1163 A	T	7 pF, 50 V, CERAMIC	70-138181
C1106	U	1000 pF, 50 V, CERAMIC	70-138170	C1163 B	T	10 pF, 50 V, CERAMIC	70-138187
C1107	U	0.022 μF, 25 V, CERAMIC	70-138253	C1168	U	1000 pF, 50 V, CERAMIC	70-138170
C1108	T	10 μF, 50 V, AL ELYC	70-135142	C1169	T	47 μF, 25 V, CERAMIC	70-135144
C1109	U	0.022 μF, 25 V, CERAMIC	70-138253	C1171	U	1000 pF, 50 V, CERAMIC	70-138170
C1110	T	47 μF, 25 V, AL ELYC	70-135144	C1173 A	T	12 pF, 50 V, CERAMIC	70-138209
C1111	U	1000 pF, 50 V, CERAMIC	70-138170	C1173 B	T	7 pF, 50 V, CERAMIC	70-138181
C1111	U	1000 pF, 50 V, CERAMIC	70-138170	C1174	U	1000 pF, 50 V, CERAMIC	70-138170
C1112	U	4700 pF, 50 V, CERAMIC	70-138163	C1176	U	1000 pF, 50 V, CERAMIC	70-138170
C1113	U	1000 pF, 50 V, CERAMIC	70-138170	C1177	U	1000 pF, 50 V, CERAMIC	70-138170
C1114	U	4700 pF, 50 V, CERAMIC	70-138163	C1178	T	0.022 μF, 25 V, CERAMIC	70-138253
C1115	U	47 pF, 50 V, CERAMIC	70-138185	C1179	T	0.022 μF, 25 V, CERAMIC	70-138253
C1116	U	5 pF, 50 V, CERAMIC	70-138166	C1182	T	47 μF, 25 V, CERAMIC	70-135144
C1117	U	100 pF, 50 V, CERAMIC	70-138175	C1184	T	47 μF, 25 V, CERAMIC	70-135144
C1118	U	1000 pF, 50 V, CERAMIC	70-138170	C1187	U	680 pF, 50 V, CERAMIC	70-138252
C1119	U	0.01 μF, 50 V, CERAMIC	70-138270	C1188 B	T	7 pF, 50 V, CERAMIC	70-138181
C1121	T	220 μF, 16 V, AL ELYC	70-135164	C1189 A	T	3 pF, 50 V, CERAMIC	70-138480
C1122	T	1 μF, 200 V, PLASTIC	70-137081	C1189 B	T	2 pF, 50 V, CERAMIC	70-138169
C1123	T	220 pF, 50 V, CERAMIC	70-138349	C1190 A	T	8 pF, 50 V, CERAMIC	70-138203
C1124	U	82 pF, 50 V, CERAMIC	70-138250	C1190 B	T	7 pF, 50 V, CERAMIC	70-138181
C1130	T	1000 pF, 50 V, CERAMIC	70-138170	C1191	T	5 pF, 50 V, CERAMIC	70-138166
C1131	U	10 μF, 10 V, AL ELYC	70-135269	C1192 B	T	7 pF, 50 V, CERAMIC	70-138181
C1132	U	82 pF, 50 V, CERAMIC	70-138250	C1193	T	5 pF, 50 V, CERAMIC	70-138166
C1133	U	0.022 μF, 25 V, CERAMIC	70-138253	C1196	U	47 pF, 50 V, CERAMIC	70-138185
C1134	U	220 pF, 50 V, CERAMIC	70-138349	C1197	U	47 pF, 50 V, CERAMIC	70-138185
C1135	T	220 μF, 16 V, AL ELYC	70-135164	C1198	U	47 pF, 50 V, CERAMIC	70-138185
C1136	U	82 pF, 50 V, CERAMIC	70-138250	C1199	U	47 pF, 50 V, CERAMIC	70-138185
C1144	T	220 μF, 16 V, AL ELYC	70-135164	C1203	U	470 pF, 50 V, CERAMIC	70-138195
C1150	U	0.022 μF, 25 V, CERAMIC	70-138253	C1204	U	220 pF, 50 V, CERAMIC	70-138349
C1151	U	0.047 μF, 50 V, CERAMIC	70-131298	C1205	U	220 pF, 50 V, CERAMIC	70-138349
C1152	U	0.01 μF, 50 V, CERAMIC	70-138270	C1206	U	220 pF, 50 V, CERAMIC	70-138349
				C1207	U	220 pF, 50 V, CERAMIC	70-138349

# PARTS

70-3400AD/BD—70-5300AD/BD

## 70-5300AD/BD ELECTRICAL PARTS (TX-413) — Continued

REF NO.	LOC	DESCRIPTION	PART NO.	REF NO.	LOC	DESCRIPTION	PART NO.
CAPACITORS (Continued)				CAPACITORS (Continued)			
C1208	U	220 pF, 50 V, CERAMIC	70-138349	C1793	T	22 pF, 50 V, CERAMIC	70-138171
C1209	U	220 pF, 50 V, CERAMIC	70-138349	C1794	U	1000 pF, 50 V, CERAMIC	70-138170
C1210	U	470 pF, 50 V, CERAMIC	70-138195	C1795	U	3 pF, 50 V, CERAMIC	70-138460
C1211	U	470 pF, 50 V, CERAMIC	70-138195	C1796	U	1000 pF, 50 V, CERAMIC	70-138170
C1212	U	470 pF, 50 V, CERAMIC	70-138195	C1797	T	22 pF, 50 V, CERAMIC	70-138171
C1403	T	47 μF, 25 V, AL ELYC	70-135144	C1798	U	1000 pF, 50 V, CERAMIC	70-138170
C1407	U	1000 pF, 50 V, CERAMIC	70-138170	C1799	T	4 pF, 50 V, CERAMIC	70-138179
C1408	T	4.7 μF, 16 V, AL ELYC	70-135172	DIODES			
C1409	U	1000 pF, 50 V, CERAMIC	70-138170	D1101	B	DWA010-TF	70-085246
C1411	U	0.01 μF, 50 V, CERAMIC	70-138270	D1401	U	DWA010	70-085246
C1412	U	1000 pF, 50 V, CERAMIC	70-138170	D1721	U	1SV166	70-085159
C1413	U	4.7 μF, 16 V, AL ELYC	70-135172	D1722	U	1SV166	70-085159
C1414	U	1000 pF, 50 V, CERAMIC	70-138170	D1723	U	1SV166	70-085159
C1417	T	47 μF, 25 V, AL ELYC	70-135144	D1724	U	1SV166	70-085159
C1418	T	47 μF, 25 V, AL ELYC	70-135144	D1725	T	MA704A	70-085247
C1721	T	680 pF, 50 V, CERAMIC	70-138252	D1726	T	1SS268	70-085248
C1722 A	U	4 pF, 50 V, CERAMIC	70-138179	D1727	T	DCB010	70-085245
C1722 B	U	3 pF, 50 V, CERAMIC	70-138460	D1731	U	1SV166	70-085159
C1723 A	U	33 pF, 50 V, CERAMIC	70-138188	D1732	U	1SV166	70-085159
C1723 B	U	22 pF, 50 V, CERAMIC	70-138171	D1733	U	1SV166	70-085159
C1724 A	U	22 pF, 50 V, CERAMIC	70-138171	D1734	U	1SV166	70-085159
C1724 B	U	15 pF, 50 V, CERAMIC	70-138205	D1735	T	MA704A	70-085247
C1725 A	U	10 pF, 50 V, CERAMIC	70-138187	D1736	U	1SV164	70-085191
C1725 B	U	5 pF, 50 V, CERAMIC	70-138186	D1737 B	U	1SV164	70-085191
C1726 B	T	680 pF, 50 V, CERAMIC	70-138252	D1738	U	1SV164	70-085191
C1727	T	0.022 μF, 25 V, CERAMIC	70-138253	INTEGRATED CIRCUITS			
C1728 B	U	22 pF, 50 V, CERAMIC	70-138171	IC1101	T	MB501L-S0P	70-076514
C1729 B	U	22 pF, 50 V, CERAMIC	70-138171	IC1102	T	MC145159FN1	70-076461
C1730	T	0.022 μF, 25 V, CERAMIC	70-138253	IC1103	T	DH1072A	70-076462
C1731	T	680 pF, 50 V, CERAMIC	70-138252	IC1104	T	MPC4741G	70-076628
C1732 A	U	5 pF, 50 V, CERAMIC	70-138166	IC1107	T	HD14011BFF/MC14011BFF	70-076506
C1732 B	U	5 pF, 50 V, CERAMIC	70-138166	IC1108	T	HD14053BFF/MC14053BFF	70-076465
C1733 A	U	33 pF, 50 V, CERAMIC	70-138188	IC1113	T	MC14094BF	70-076467
C1733 B	U	18 pF, 50 V, CERAMIC	70-138206	IC1401	T	AN6541	70-076253
C1734 A	U	27 pF, 50 V, CERAMIC	70-138185	IC1402	T	S-81250HG	70-076753
C1734 B	U	18 pF, 50 V, CERAMIC	70-138206	IC1403	T	S-81250HG	70-076753
C1735 A	U	5 pF, 50 V, CERAMIC	70-138166	TRANSISTORS			
C1735 B	U	7 pF, 50 V, CERAMIC	70-138181	Q1101	T	2SC2462LC	70-080288
C1736 B	T	680 pF, 50 V, CERAMIC	70-138252	Q1103	T	IMH1	70-080296
C1737	T	0.022 μF, 25 V, CERAMIC	70-138253	Q1106	T	IMD3	70-080297
C1738	U	1000 pF, 50 V, CERAMIC	70-138170	Q1107	T	IMD3	70-080297
C1739	U	1000 pF, 50 V, CERAMIC	70-138170	Q1112	T	2SC3357-T2	70-080298
C1741 B	U	1 pF, 50 V, CERAMIC	70-138174	Q1113	U	2SC2462LC	70-080288
C1742 A	U	33 pF, 50 V, CERAMIC	70-138188	Q1115	T	DTC124K	70-080300
C1742 B	U	47 pF, 50 V, CERAMIC	70-138185	Q1116	T	IMH1	70-080296
C1743 B	U	1 pF, 50 V, CERAMIC	70-138174	Q1401	T	2SB798	70-080164
C1744 B	U	100 pF, 50 V, CERAMIC	70-138175	Q1404	T	DTC124EK	70-080300
C1745 B	U	3 pF, 50 V, CERAMIC	70-138590	Q1703	T	2SC3356	70-080192
C1746 B	U	22 pF, 50 V, CERAMIC	70-138171	Q1721	T	3SK151GR	70-080303
C1747	U	1000 pF, 50 V, CERAMIC	70-138170	Q1722	T	2SC3356	70-080192
C1749	T	1000 pF, 50 V, CERAMIC	70-138170	Q1731	T	2SC3356	70-080192
C1751 A	T	5 pF, 50 V, CERAMIC	70-138166	Q1732	T	2SC3356	70-080192
C1752	T	3 pF, 50 V, CERAMIC	70-138460	Q1733	T	2SC3356	70-080192
C1754 A	T	7 pF, 50 V, CERAMIC	70-138181	Q1733	T	2SC3356	70-080192
C1754 B	T	5 pF, 50 V, CERAMIC	70-138166	RESISTORS			
C1755	T	1000 pF, 50 V, CERAMIC	70-138170	R1102	U	68 kΩ, 1/10 W, METAL	70-144119
C1756	T	1000 pF, 50 V, CERAMIC	70-138170	R1103	U	22 kΩ, 1/10 W, METAL	70-144121
C1757	T	4 pF, 50 V, CERAMIC	70-138179	R1104	U	100 kΩ, 1/10 W, METAL	70-144321
C1758 A	T	10 pF, 50 V, CERAMIC	70-138187	R1105	U	47 Ω, 1/10 W, METAL	70-144130
C1758 B	T	5 pF, 50 V, CERAMIC	70-138166	R1106	U	1 MΩ, 1/10 W, METAL	70-144155
C1759 A	T	5 pF, 50 V, CERAMIC	70-138166	R1107	U	47 kΩ, 1/10 W, METAL	70-144231
C1759 B	T	4 pF, 50 V, CERAMIC	70-138179	R1108	U	10 kΩ, 1/10 W, METAL	70-144120
C1760 B	T	10 pF, 50 V, CERAMIC	70-138187	R1109	U	0 Ω, 1/10 W, METAL	70-144106
C1761	T	0.022 μF, 25 V, CERAMIC	70-138253	R1110	U	0 Ω, 1/10 W, METAL	70-144106
C1762	T	0.022 μF, 25 V, CERAMIC	70-138253	R1113	U	10 kΩ, 1/10 W, METAL	70-144120
C1764	T	1000 pF, 50 V, CERAMIC	70-138170	R1116	U	22 kΩ, 1/10 W, METAL	70-144121
C1766	U	1000 pF, 50 V, CERAMIC	70-138170	R1117	U	47 kΩ, 1/10 W, METAL	70-144231
C1767	T	1000 pF, 50 V, CERAMIC	70-138170	R1118	U	100 kΩ, 1/10 W, METAL	70-144321
C1768 A	T	5 pF, 50 V, CERAMIC	70-138166	R1119	U	1 kΩ, 1/10 W, METAL	70-144125
C1773	U	680 pF, 50 V, CERAMIC	70-138252	R1120	U	150 kΩ, 1/10 W, METAL	70-144129
C1774	U	680 pF, 50 V, CERAMIC	70-138252	R1121	U	47 kΩ, 1/10 W, METAL	70-144231
C1780	U	1000 pF, 50 V, CERAMIC	70-138170				
C1782 B	U	22 pF, 50 V, CERAMIC	70-138171				
C1784	U	1000 pF, 50 V, CERAMIC	70-138170				
C1785	U	1000 pF, 50 V, CERAMIC	70-138170				
C1789	T	22 pF, 50 V, CERAMIC	70-138171				
C1791	U	1000 pF, 50 V, CERAMIC	70-138170				
C1792 A	U	6 pF, 50 V, CERAMIC	70-138348				
C1792 B	U	4 pF, 50 V, CERAMIC	70-138179				