



**MOTOROLA**  
*intelligence everywhere™*



# CDM1550•LS+™

200 MHz  
700 MHz

Professional Series  
Two-Way Radio Detailed Service Manual

## Product Software License Agreement

THIS LICENSE AGREEMENT BETWEEN YOU, THE USER, AND MOTOROLA, APPLIES TO THE SOFTWARE EMBEDDED IN OR DELIVERED WITH THE ACCOMPANYING MOTOROLA PRODUCT ("SOFTWARE"), AND IS APPLICABLE UNLESS A SIGNED LICENSE AGREEMENT COVERING ITS SUBJECT MATTER HAS BEEN EXECUTED BETWEEN YOU AND MOTOROLA. BY USING THE PRODUCT, YOU ACKNOWLEDGE THAT THIS AGREEMENT HAS BEEN READ AND UNDERSTOOD AND THAT YOU AGREE TO BE BOUND BY ITS TERMS AND CONDITIONS. IF YOU DO NOT AGREE, YOU ARE NOT LICENSED TO USE THE PRODUCT, AND IF YOU ARE THE PURCHASER OF THE PRODUCT, YOU SHOULD IMMEDIATELY RETURN THE PRODUCT IN ITS ENTIRETY TO ITS PLACE OF PURCHASE FOR A REFUND.

Motorola grants to You a non-exclusive license to use the SOFTWARE in the manner described in the documentation associated with the product. Motorola retains ownership of the SOFTWARE including all patent, copyrights, and other intellectual property rights. You may transfer this license to use the SOFTWARE as long as the transferee agrees to be bound by the terms of this Agreement.

You agree not to reverse engineer or create derivative works of the SOFTWARE; not to transmit the SOFTWARE electronically; not to modify, configure, or use the SOFTWARE in any manner not authorized by MOTOROLA; and, except as an integral part of the product, not to rent, lease, or convey the SOFTWARE.

MOTOROLA SHALL NOT BE LIABLE FOR INCIDENTAL OR CONSEQUENTIAL DAMAGES ARISING FROM THE USE OF THIS SOFTWARE.

With respect to the U.S. Government, if acquired under FAR policy (52.227-19), the SOFTWARE is provided with Restricted Rights, and if acquired under DFARS policy (227.7202), then the SOFTWARE is provided only with the commercial rights of this Agreement.

This license is effective until terminated. It will terminate immediately and automatically if You fail to comply with any term of this Agreement.

You agree that this is the complete and exclusive statement of the agreement between You and Motorola and that any modification of these terms shall be made only by mutual agreement and evidenced by written amendment signed by both parties. This Agreement shall be governed and interpreted by the laws of the State of Illinois, United States of America.

## Computer Software Copyrights

This manual may not be reproduced, in whole or in part, in any form whatsoever, without the express written permission of Motorola, Inc.

The Motorola products described in this manual contain one or more computer programs. These computer programs are protected by copyright law and international treaties. Unauthorized reproduction or distribution of these programs, or any part thereof, may result in severe civil and criminal penalties, and will be prosecuted to the maximum extent possible under the law. U.S. and international patents pending.

**This product is covered by one or more issued U.S. Patents. Other Patent applications pending.**

# Table of Contents

|  |     |
|--|-----|
| <i>Product Safety and RF Exposure Compliance</i> ..... | vii |
|--|-----|

## Chapter 1 *Introduction*

|   |     |
|---|-----|
| 1.1 Scope of Manual.....                      | 1-1 |
| 1.2 Warranty and Service Support.....         | 1-1 |
| 1.2.1 Warranty Period .....                   | 1-1 |
| 1.2.2 Return Instructions.....                | 1-1 |
| 1.2.3 After Warranty Period .....             | 1-1 |
| 1.3 Related Documents .....                   | 1-2 |
| 1.4 Technical Support.....                    | 1-2 |
| 1.5 Warranty and Repairs.....                 | 1-2 |
| 1.6 Radio Model Chart and Specifications..... | 1-3 |
| 1.7 Radio Model Information.....              | 1-3 |

## Chapter 2 *Theory of Operation*

|   |      |
|---|------|
| 2.1 Overview.....   | 2-1  |
| 2.2 Controller .....  | 2-1  |
| 2.2.1 Radio Power Distribution .....                              | 2-2  |
| 2.2.2 Automatic On/Off .....                                      | 2-3  |
| 2.2.3 Emergency.....  | 2-4  |
| 2.2.4 Mechanical On/Off .....                                     | 2-4  |
| 2.2.5 Ignition .....  | 2-4  |
| 2.2.6 Microprocessor Clock Synthesizer.....                       | 2-5  |
| 2.2.7 Serial Peripheral Interface (SPI) .....                     | 2-5  |
| 2.2.8 SBEP Serial Interface .....                                 | 2-6  |
| 2.2.9 General Purpose Input/Output.....                           | 2-6  |
| 2.2.10 Normal Microprocessor Operation.....                       | 2-7  |
| 2.2.11 Static Random Access Memory (SRAM).....                    | 2-8  |
| 2.3 Controller Board Audio and Signalling Circuits.....           | 2-8  |
| 2.3.1 Audio Signalling Filter IC with Compander (ASFIC CMP) ..... | 2-8  |
| 2.3.2 Transmit Audio Circuits.....                                | 2-9  |
| 2.3.3 Microphone Input Path.....                                  | 2-9  |
| 2.3.3.1 PTT Sensing and TX Audio Processing .....                 | 2-10 |
| 2.3.3.2 TX Secure Audio (optional) .....                          | 2-10 |
| 2.3.3.3 Option Board Transmit Audio .....                         | 2-10 |
| 2.3.4 Transmit Signalling Circuits .....                          | 2-11 |
| 2.3.4.1 Sub-Audible Data (PL/DPL) .....                           | 2-11 |
| 2.3.4.2 High Speed Data .....                                     | 2-12 |

---

|         |   |      |
|---------|---|------|
| 2.3.4.3 | Dual Tone Multiple Frequency (DTMF) Data .....            | 2-12 |
| 2.3.5   | Receive Audio Circuits .....                              | 2-13 |
| 2.3.5.1 | Squelch Detect.....                                       | 2-13 |
| 2.3.5.2 | Audio Processing and Digital Volume Control .....         | 2-13 |
| 2.3.5.3 | Audio Amplification Speaker (+) Speaker (-) .....         | 2-14 |
| 2.3.5.4 | Handset Audio .....                                       | 2-14 |
| 2.3.5.5 | Filtered Audio and Flat Audio.....                        | 2-15 |
| 2.3.5.6 | RX Secure Audio Option.....                               | 2-15 |
| 2.3.5.7 | Option Board Receive Audio.....                           | 2-15 |
| 2.3.6   | Receive Signalling Circuits.....                          | 2-16 |
| 2.3.6.1 | Sub-Audible Data (PL/DPL) and High Speed Data Decoder ... | 2-16 |
| 2.3.6.2 | Alert Tone Circuits .....                                 | 2-16 |
| 2.3.6.3 | Voice Storage Option.....                                 | 2-17 |
| 2.4     | 200 MHz Receiver Front-End.....                           | 2-18 |
| 2.4.1   | Receiver Front End .....                                  | 2-18 |
| 2.4.2   | Receiver Back End.....                                    | 2-19 |
| 2.5     | Transmitter Power Amplifier (PA) 25 W .....               | 2-19 |
| 2.5.1   | Power Controlled Stage .....                              | 2-20 |
| 2.5.2   | Pre-Driver Stage.....                                     | 2-20 |
| 2.5.3   | Final Stage .....   | 2-20 |
| 2.5.4   | Directional Coupler.....                                  | 2-20 |
| 2.5.5   | Antenna Switch .....                                      | 2-20 |
| 2.5.6   | Harmonic Filter .....                                     | 2-21 |
| 2.5.7   | Power Control.....  | 2-21 |
| 2.6     | Frequency Synthesis.....                                  | 2-21 |
| 2.6.1   | Reference Oscillator.....                                 | 2-21 |
| 2.6.2   | Fractional-N Synthesizer .....                            | 2-22 |
| 2.6.3   | Voltage Controlled Oscillator (VCO).....                  | 2-23 |
| 2.6.4   | Synthesizer Operation .....                               | 2-24 |
| 2.7     | 700 MHz Receiver Front-End.....                           | 2-25 |
| 2.7.1   | Receiver Front-End .....                                  | 2-25 |
| 2.7.2   | Receiver Back-End.....                                    | 2-25 |
| 2.8     | Transmitter Power Amplifier (PA) 15 W .....               | 2-26 |
| 2.8.1   | Power Controlled Stage .....                              | 2-26 |
| 2.8.2   | Driver Stage .....  | 2-27 |
| 2.8.3   | Final Stage .....   | 2-27 |
| 2.8.4   | Antenna Switch .....                                      | 2-27 |
| 2.8.5   | Harmonic Filter .....                                     | 2-27 |
| 2.8.6   | Bi-Directional Coupler .....                              | 2-27 |
| 2.8.7   | Power Control.....  | 2-27 |
| 2.9     | Frequency Synthesis.....                                  | 2-28 |
| 2.9.1   | Reference Oscillator .....                                | 2-28 |
| 2.9.2   | Fractional-N Synthesizer .....                            | 2-28 |
| 2.9.3   | Voltage Controlled Oscillator (VCO).....                  | 2-29 |
| 2.9.4   | Synthesizer Operation.....                                | 2-31 |

|  |      |
|--|------|
| 2.10 Control Head (CDM1550•LS+) .....                | 2-31 |
| 2.10.1 Power Supplies .....                          | 2-31 |
| 2.10.2 Power On / Off .....                          | 2-32 |
| 2.10.3 Microprocessor Circuit .....                  | 2-32 |
| 2.10.4 SBEP Serial Interface .....                   | 2-32 |
| 2.10.5 Keypad Keys.....                              | 2-33 |
| 2.10.6 Status LED and Back Light Circuit.....        | 2-33 |
| 2.10.7 Liquid Crystal Display (LCD).....             | 2-33 |
| 2.10.8 Microphone Connector Signals.....             | 2-34 |
| 2.10.9 Speaker.....                                  | 2-35 |
| 2.10.10 Electrostatic Transient Protection .....     | 2-35 |
| 2.11 PassPort Trunking Controller Board (PTCB) ..... | 2-35 |

### **Chapter 3     *Maintenance***

|   |      |
|---|------|
| 3.1 Introduction .....                                | 3-1  |
| 3.2 Preventive Maintenance .....                      | 3-1  |
| 3.2.1 Inspection.....                                 | 3-1  |
| 3.2.2 Cleaning.....                                   | 3-1  |
| 3.3 Safe Handling of CMOS and LDMOS.....              | 3-2  |
| 3.4 General Repair Procedures and Techniques .....    | 3-2  |
| 3.5 Recommended Test Tools.....                       | 3-5  |
| 3.6 Receiver Troubleshooting Chart (200 MHz) .....    | 3-6  |
| 3.7 Receiver Troubleshooting Chart (700 MHz) .....    | 3-8  |
| 3.8 Transmitter Troubleshooting Chart (200 MHz) ..... | 3-10 |
| 3.9 Transmitter Troubleshooting Chart (700 MHz) ..... | 3-11 |
| 3.10 Synthesizer Troubleshooting Chart (200 MHz)..... | 3-12 |
| 3.11 Synthesizer Troubleshooting Chart (700 MHz)..... | 3-13 |
| 3.12 VCO Troubleshooting Chart (200 MHz).....         | 3-15 |
| 3.13 VCO Troubleshooting Chart (700 MHz).....         | 3-16 |

### **Chapter 4     *Schematic Diagrams, Overlays, and Parts Lists***

|  |      |
|--|------|
| 4.1 Introduction .....   | 4-1  |
| 4.1.1 Notes For All Schematics and Circuit Boards .....        | 4-1  |
| Figure 4-1. CDM1550•LS+ Control Head Top Overlay .....         | 4-3  |
| Figure 4-2. CDM1550•LS+ Control Head Bottom Overlay .....      | 4-4  |
| Figure 4-3. CDM1550•LS+ Control Head Schematic Diagram .....   | 4-5  |
| Figure 4-4. CDM1550•LS+ Control Head Keypad Schematic .....    | 4-6  |
| Figure 4-5. CDM1550•LS+ Control Head Backlight Schematic ..... | 4-7  |
| Figure 4-6. CDM1550•LS+ Control Head Display Schematic .....   | 4-8  |
| CDM1550•LS+ Control Head Parts List.....                       | 4-9  |
| Figure 4-7. 200 MHz Main Board Top Side PCB .....              | 4-11 |
| Figure 4-8. 200 MHz Main Board Bottom Side PCB .....           | 4-12 |
| Figure 4-9. 200 MHz Receiver Front End Schematic Diagram ..... | 4-13 |

---

|              |   |      |
|--------------|---|------|
| Figure 4-10. | 200 MHz Receiver IF Schematic Diagram .....                   | 4-14 |
| Figure 4-11. | 200 MHz Transmitter Power Amplifier Schematic Diagram .....   | 4-15 |
| Figure 4-12. | 200 MHz Fractional-N Synthesizer Schematic Diagram .....      | 4-16 |
| Figure 4-13. | 200 MHz Voltage Controlled Oscillator Schematic Diagram ..... | 4-17 |
| Figure 4-14. | 200 MHz Overall Controller Schematic Diagram .....            | 4-18 |
| Figure 4-15. | 200 MHz Microprocessor Schematic Diagram .....                | 4-19 |
| Figure 4-16. | 200 MHz Audio Schematic Diagram .....                         | 4-20 |
| Figure 4-17. | 200 MHz Interface and Connectors Schematic Diagram .....      | 4-21 |
| Figure 4-18. | 200 MHz Power Supply Schematic Diagram .....                  | 4-22 |
|              | 200 MHz Radio Parts List.....                                 | 4-23 |
| Figure 4-19. | 700 MHz Main Board Top Side PCB .....                         | 4-27 |
| Figure 4-20. | 700 MHz Main Board Bottom Side PCB .....                      | 4-28 |
| Figure 4-21. | 700 MHz Receiver Front End Schematic Diagram .....            | 4-29 |
| Figure 4-22. | 700 MHz Receiver IF Schematic Diagram .....                   | 4-30 |
| Figure 4-23. | 700 MHz Transmitter Power Amplifier Schematic Diagram .....   | 4-31 |
| Figure 4-24. | 700 MHz Fractional-N Synthesizer Schematic Diagram .....      | 4-32 |
| Figure 4-25. | 700 MHz Voltage Controlled Oscillator Schematic Diagram ..... | 4-33 |
| Figure 4-26. | 700 MHz Overall Controller Schematic Diagram .....            | 4-34 |
| Figure 4-27. | 700 MHz Microprocessor Schematic Diagram .....                | 4-35 |
| Figure 4-28. | 700 MHz Audio Schematic Diagram .....                         | 4-36 |
| Figure 4-29. | 700 MHz Interface and Connectors Schematic Diagram .....      | 4-37 |
| Figure 4-30. | 700 MHz Power Supply Schematic Diagram .....                  | 4-38 |
|              | 700 MHz Radio Parts List.....                                 | 4-39 |
| Figure 4-31. | PassPort Trunking Controller Board Side 1 & 2 .....           | 4-45 |
| Figure 4-32. | PassPort Trunking Controller Board Schematic Diagram .....    | 4-46 |

# List of Figures

|              |   |      |
|--------------|---|------|
| Figure 2-1.  | Controller Block Diagram.....                                 | 2-1  |
| Figure 2-2.  | DC Power Distribution Block Diagram .....                     | 2-3  |
| Figure 2-3.  | Transmit Audio Paths .....                                    | 2-9  |
| Figure 2-4.  | Transmit Signalling Paths .....                               | 2-11 |
| Figure 2-5.  | Receive Audio Paths .....                                     | 2-13 |
| Figure 2-6.  | Receive Signalling Paths .....                                | 2-16 |
| Figure 2-7.  | 200 MHz Receiver Block Diagram.....                           | 2-18 |
| Figure 2-8.  | 200 MHz Transmitter Block Diagram.....                        | 2-19 |
| Figure 2-9.  | 200 MHz Synthesizer Block Diagram .....                       | 2-22 |
| Figure 2-10. | 200 MHz VCO Block Diagram .....                               | 2-23 |
| Figure 2-11. | 700 MHz Receiver Block Diagram.....                           | 2-25 |
| Figure 2-12. | 700 MHz Transmitter Block Diagram.....                        | 2-26 |
| Figure 2-13. | 700 MHz Synthesizer Block Diagram .....                       | 2-29 |
| Figure 2-14. | 700 MHz VCO Block Diagram .....                               | 2-30 |
| Figure 4-1.  | CDM1550•LS+ Control Head Top Overlay .....                    | 4-3  |
| Figure 4-2.  | CDM1550•LS+ Control Head Bottom Overlay.....                  | 4-4  |
| Figure 4-3.  | CDM1550•LS+ Control Head Schematic Diagram .....              | 4-5  |
| Figure 4-4.  | CDM1550•LS+ Control Head Keypad Schematic .....               | 4-6  |
| Figure 4-5.  | CDM1550•LS+ Control Head Backlight Schematic .....            | 4-7  |
| Figure 4-6.  | CDM1550•LS+ Control Head Display Schematic.....               | 4-8  |
| Figure 4-7.  | 200 MHz Main Board Top Side PCB .....                         | 4-11 |
| Figure 4-8.  | 200 MHz Main Board Bottom Side PCB.....                       | 4-12 |
| Figure 4-9.  | 200 MHz Receiver Front End Schematic Diagram .....            | 4-13 |
| Figure 4-10. | 200 MHz Receiver IF Schematic Diagram .....                   | 4-14 |
| Figure 4-11. | 200 MHz Transmitter Power Amplifier Schematic Diagram .....   | 4-15 |
| Figure 4-12. | 200 MHz Fractional-N Synthesizer Schematic Diagram .....      | 4-16 |
| Figure 4-13. | 200 MHz Voltage Controlled Oscillator Schematic Diagram ..... | 4-17 |
| Figure 4-14. | 200 MHz Overall Controller Schematic Diagram .....            | 4-18 |
| Figure 4-15. | 200 MHz Microprocessor Schematic Diagram .....                | 4-19 |
| Figure 4-16. | 200 MHz Audio Schematic Diagram.....                          | 4-20 |
| Figure 4-17. | 200 MHz Interface and Connectors Schematic Diagram .....      | 4-21 |
| Figure 4-18. | 200 MHz Power Supply Schematic Diagram.....                   | 4-22 |
| Figure 4-19. | 700 MHz Main Board Top Side PCB .....                         | 4-27 |
| Figure 4-20. | 700 MHz Main Board Bottom Side PCB .....                      | 4-28 |
| Figure 4-21. | 700 MHz Receiver Front End Schematic Diagram .....            | 4-29 |
| Figure 4-22. | 700 MHz Receiver IF Schematic Diagram .....                   | 4-30 |
| Figure 4-23. | 700 MHz Transmitter Power Amplifier Schematic Diagram .....   | 4-31 |
| Figure 4-24. | 700 MHz Fractional-N Synthesizer Schematic Diagram .....      | 4-32 |
| Figure 4-25. | 700 MHz Voltage Controlled Oscillator Schematic Diagram ..... | 4-33 |
| Figure 4-26. | 700 MHz Overall Controller Schematic Diagram .....            | 4-34 |
| Figure 4-27. | 700 MHz Microprocessor Schematic Diagram .....                | 4-35 |
| Figure 4-28. | 700 MHz Audio Schematic Diagram.....                          | 4-36 |
| Figure 4-29. | 700 MHz Interface and Connectors Schematic Diagram .....      | 4-37 |
| Figure 4-30. | 700 MHz Power Supply Schematic Diagram.....                   | 4-38 |
| Figure 4-31. | PassPort Trunking Controller Board Side 1 & 2 .....           | 4-45 |
| Figure 4-32. | PassPort Trunking Controller Board Schematic Diagram .....    | 4-46 |

# List of Tables

|            |                              |     |
|------------|------------------------------|-----|
| Table 1-1. | Related Documents.....       | 1-2 |
| Table 1-2. | Radio Model Number .....     | 1-3 |
| Table 3-1. | Recommended Test Tools ..... | 3-5 |



---

## PRODUCT SAFETY AND RF EXPOSURE COMPLIANCE



**Caution**

Before using this product, read the operating instructions for safe usage contained in the Product Safety and RF Exposure booklet enclosed with your radio.

### ATTENTION!

**This radio is restricted to occupational use only to satisfy FCC RF energy exposure requirements.**

Before using this product, read the RF energy awareness information and operating instructions in the Product Safety and RF Exposure booklet enclosed with your radio (Motorola Publication part number 68P81095C99) to ensure compliance with RF energy exposure limits.

For a list of Motorola-approved antennas, batteries, and other accessories, visit the following web site which lists approved accessories: <http://www.motorola.com/cgiss/index.shtml>.

This page intentionally left blank

---

# Chapter 1

## Introduction

### 1.1 Scope of Manual

This manual is intended for use by service technicians familiar with similar types of equipment. It contains service information required for the equipment described and is current as of the printing date. Changes that occur after the printing date are incorporated by a complete manual revision or alternatively, as additions.

**Note:** Before operating or testing these units, please read the Safety Information Section in the front of this manual.

### 1.2 Warranty and Service Support

Motorola offers long term support for its products. This support includes full exchange and/or repair of the product during the warranty period, and service/repair or spare parts support out of warranty. Any "return for exchange" or "return for repair" by an authorized Motorola dealer must be accompanied by a warranty claim form. Warranty claim forms are obtained by contacting customer service.

#### 1.2.1 Warranty Period

The terms and conditions of warranty are defined fully in the Motorola dealer or distributor or reseller contract. These conditions may change from time to time and the following notes are for guidance purposes only.

#### 1.2.2 Return Instructions

In instances where the product is covered under a "return for replacement" or "return for repair" warranty, a check of the product should be performed prior to shipping the unit back to Motorola. This is to ensure that the product has been correctly programmed or has not been subjected to damage outside the terms of the warranty.

Prior to shipping any radio back to a Motorola warranty depot, please contact the appropriate customer service for instructions. All returns must be accompanied by a warranty claim form, available from your customer services representative. Products should be shipped back in the original packaging, or correctly packaged to ensure no damage occurs in transit.

#### 1.2.3 After Warranty Period

After the Warranty period, Motorola continues to support its products in two ways:

Firstly, Motorola's Accessories and Aftermarket Division (ADD) offers a repair service to both end users and dealers at competitive prices.

Secondly, Motorola's service department supplies individual parts and modules that can be purchased by dealers who are technically capable of performing fault analysis and repair.

### 1.3 Related Documents

The following documents are directly related to the use and maintainability of this product.

**Table 1-1. Related Documents**

| Title  | Part Number |
|--|-------------|
| 200/700 MHz Professional Radio Mobile<br>Level 1&2 Basic Service Manual- English | 6864110R16  |

### 1.4 Technical Support

Technical support is available to assist the dealer/distributor and self-maintained customers in resolving any malfunction which may be encountered. Initial contact should be by telephone to customer resources wherever possible. When contacting Motorola technical support, be prepared to provide the product model number and the unit's serial number. The contact locations and telephone numbers are listed below.

#### **Motorola Radio Support Center**

3761 South Central Avenue  
Rockford, IL 61102-4294  
1-800-227-6772  
1-815-489-1000

#### **Motorola Toronto Service Center**

400 Matheson Blvd. W,  
Mississauga, Ontario, Canada L5R 3M1  
1-800-543-3222  
1-416-756-5841  
1-888-331-9872 (Fax)

#### **Motorola U.S. Federal Government Depot**

4395 Nicole Drive  
Lanham, MD 20706  
1-800-969-6680  
1-301-731-6676

### 1.5 Warranty and Repairs

For warranty and repairs, contact Motorola Technical Support as listed below. Be prepared to provide the product **model number** and the unit's **serial number**.

Some replacement parts, spare parts, and/or product information can be ordered directly. If a complete Motorola part number is assigned to the part, and it is not identified as "Depot ONLY", the part is available from Motorola Accessories and Aftermarket Division (AAD). If no part number is assigned, the part is not normally available from Motorola. If the part number is appended with an asterisk, the part is serviceable by a Motorola depot only. If a parts list is not included, this generally means that no user-serviceable parts are available for that kit or assembly. Technical Support the product **model number** and the unit's **serial number**.

#### **Parts Order Entry:**

7:00 A.M. to 7:00 P.M. (Central Standard Time)  
Monday through Friday (Chicago, U.S.A.)

#### **To Order Parts:**

1-800-422-4210, or 847-538-8023  
 1-800-826-1913, or 410-712-4907 (U.S. Federal Government)  
 TELEX: 280127  
 FAX: 1-847-538-8198  
 FAX: 1-410-712-4991 (U.S. Federal Government)  
 (U.S.A.) after hours or weekends:  
 1-800-925-4357

### Motorola Parts

Accessories and Aftermarket Division  
 (United States and Canada)  
 Attention: Order Processing  
 2200 Galvin Dr.  
 Elgin, IL 60123

### Parts Identification

1-800-422-4210 menu 3

## 1.6 Radio Model Chart and Specifications

The radio model charts and specifications are located in the Basic Service Manual listed under the Related Documents paragraph of this chapter.

## 1.7 Radio Model Information

The model number and serial number are located on a label attached to the back of your radio. You can determine the RF output power, frequency band, protocols, and physical packages from these numbers. The example below shows one portable radio model number and its specific characteristics.

**Table 1-2.** Radio Model Number

**Example:** AAM25MHF4DP5AN

|                                       | Type of Unit         | Model Series | Freq. Band                           | Power Level                             | Physical Packages | Channel Spacing | Protocol       | Feature Level                           | Model Revision | Model Package |
|---------------------------------------|----------------------|--------------|--------------------------------------|---|-------------------|-----------------|----------------|---|----------------|---------------|
| AA<br>↑<br>AA = Motorola Internal Use | M<br>↑<br>M = Mobile | 25           | M<br>(200 MHz)<br><br>5<br>(700 MHz) | H<br>1 to<br>25 W<br>or<br>1 to<br>15 W | F<br>CDM1550•LS+  | 4<br>12.5 kHz   | DP<br>PassPort | 5<br>4 Chan.,<br>64 Chan.,<br>128 Chan. | A              | N             |

This page intentionally left blank

## Chapter 2

# Theory of Operation

### 2.1 Overview

This chapter provides a detailed theory of operation for the radio and its components. The radio is designed as a single board unit consisting of a transmitter, receiver, and controller circuits. The board also accepts one additional option board that can provide functions such as secure voice/data, voice storage, or a signalling decoder.

A control head, mounted directly on the front of the radio or remotely connected by an extension cable, provides a user interface for controlling the various features of the radio. The control head contains LED indicators, microphone connector, and buttons depending on the radio type, display, and speaker.

The rear of the radio provides connections for a power, antenna, and accessory cable. The accessory cable provides connections for items such as an external speaker, emergency switch, foot operated PTT, and ignition sensing, etc.

### 2.2 Controller

The radio controller, shown in Figure 2-1, is divided into three main functions:

- Digital control
- Audio processing
- Voltage regulation.

The digital control section of the radio consists of a microprocessor ( $\mu\text{P}$ ), support memory, support logic, signal MUX ICs, on/off circuit, and general purpose input/output circuits.

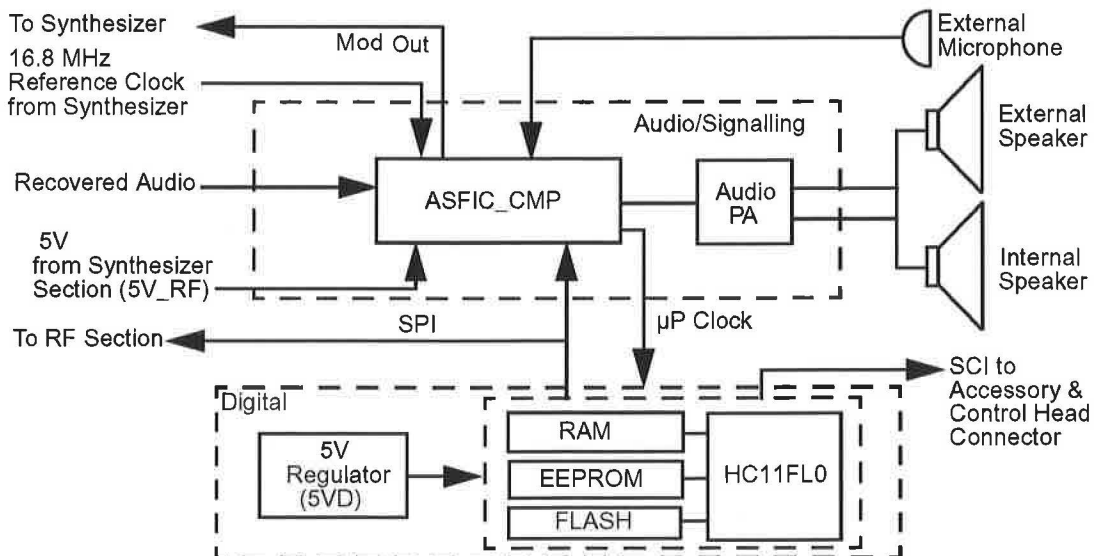

Figure 2-1. Controller Block Diagram

### 2.2.1 Radio Power Distribution

The dc power distribution throughout the radio board is shown in Figure 2-2. Voltage regulation for the controller is provided by four separate devices:

- U0651 (MC78M05) +5 volts
- U0641 (LM2941) +9.3 volts
- U0611 (LM2941) +12 volts
- VSTBY 5V (a combination of R0621 and VR0621)
- U3211 Additional 5 volt regulator located in the RF section.

The dc voltage applied to connector J0601 supplies power directly to the following:

- Electronic on/off control
- RF power amplifier
- 12 volt regulator
- 9.3 volt regulator
- Audio PA
- 5.6 volt stabilization circuit
- 9.3 volt regulator (U0641) supplies power to the 5 volt regulator (U0651) and 6 volt voltage divider Q0681

Regulator U0641 generates the 9.3 volts required by some audio circuits, the RF and power control circuits. Input and output capacitors C0641 and C0644 / C0645 are used to reduce high frequency noise. Resistors R0642 / R0643 set the output voltage of the regulator. If the voltage at pin 1 is greater than 1.3 volts the regulator output decreases and if the voltage is less than 1.3 volts the regulator output increases. This regulator output is enabled by a 0 volt signal on pin 2. Transistors Q0661, Q0641, and R0641 are used to disable the regulator when the radio is turned off.

Voltage regulator U0651 provides 5 volts operating voltage for the digital circuits. Operating voltage is from the regulated 9.3volts supply. Input and output capacitors (C0651 / C0652 and C0654 / C0655) reduce high frequency noise and provide proper operation during battery transients. Voltage sense device U0652 or alternatively U0653 provides a reset output that goes to 0 volts if the regulator output goes below 4.5 volts. This resets the controller to prevent improper operation. Diode D0651 prevents discharge of C0652 by negative spikes on the 9.3 volt supply.

Transistor Q0681 and resistors R0681 / R0682 divide the regulated 9.3 volts down to about 6 volts. This voltage supplies the 5 volt regulator, located on the RF section. By reducing the supply voltage of the regulator, the power dissipation is divided between the RF section and the controller section.

The VSTBY signal, derived directly from the supply voltage by components R0621 and VR0621, buffers the internal RAM. Capacitor C0622 allows the battery voltage to be disconnected for several seconds without losing RAM information. Dual diode D0621 prevents radio circuits from discharging this capacitor. When the supply voltage is applied to the radio, C0622 is charged via R0621 and D0621. When the radio is switched on, the  $\mu$ P enters the wrong mode if the voltage across C0622 is still too low. The regulated 5 volts charges C0622 via diode D0621.



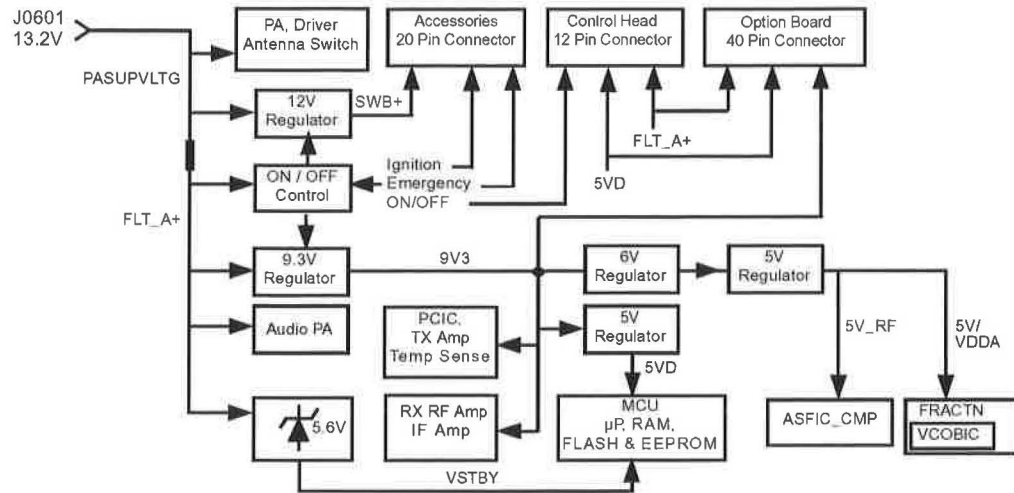

**Figure 2-2.** DC Power Distribution Block Diagram

The INT SW B+ voltage from switching transistor Q0661 provides power to the circuit controlling the audio PA output. The voltage is monitored by the  $\mu$ P through voltage divider R0671/R0672 and the line battery voltage. Diode VR0671 limits the divided voltage to 5.6 volts to protect the  $\mu$ P.

Regulator U0611 generates the voltage for the switched supply voltage output (SWB+) at accessory connector J0501, pin 13. U0611 operates as a switch with voltage and current limit. Resistors R0611/R0612 set the maximum output voltage to 16.5 volts. This limitation is only active at high supply voltage levels. The regulator output is enabled by a 0 volt signal at Q0661, pin 2. Q0641 and R0641 disable the regulator when the radio is turned off. Input and output capacitors C0603 and C0611/C0612 reduce high frequency noise.

Diode VR0601 protects against transients and reverse polarity of the supply voltage.

## 2.2.2 Automatic On/Off

The radio software and/or external triggers turn the radio on or off without direct user action. For example, automatic turn on when ignition is sensed and off when ignition is off.

Q0661 provides the INT SW B+ voltage to the various radio circuits and to enable the voltage regulators via transistor Q0641 which contains a pnp and an npn transistor that provide an electronic on/off switch. The switch is on when the collector of the npn transistor within Q0661 is low. When the radio is off the collector is at supply voltage level. This effectively prevents current flow from emitter to collector of the pnp transistor. When the radio is turned on the voltage at the base of the npn transistor is pulled high and the pnp transistor switches on (saturation). With the INT SWB+ voltage now at supply voltage level, transistor Q0641 pulls pin 2 of the voltage regulators U0611 and U0641 to ground level, enabling their outputs.

The electronic on/off circuits are enabled by the  $\mu$ P through ASFIC CMP port GCB2, line DC POWER ON, emergency switch (line EMERGENCY CONTROL), the mechanical On/Off/Volume knob on the control head (line ON OFF CONTROL), or the ignition sense circuits (line IGNITION CONTROL). If any of the four paths cause a low at the collector of the npn transistor within Q0661, the electronic "ON" is engaged.

### 2.2.3 Emergency

The emergency switch (J0501, pin 9), when engaged, grounds the base of Q0662 via the EMERGENCY CONTROL line. This switches Q0662 off and resistor R0662 pulls the collector of Q0662 and the base of Q0663 to levels above two volts. Transistor Q0663 then switches on and pulls the collector of the npn transistor within Q0661 to ground level. This enables the voltage regulators via Q0641. When the emergency switch is released, R0541 pulls the base of Q0662 up to 0.6 volts causing the collector of transistor Q0662 to go low (0.2 volts), switching Q0663 off.

While the radio is on, the  $\mu\text{P}$  monitors the voltage at the emergency input on the accessory connector via pin 60 and the GP5 IN ACC9 line. Three different conditions can exist: no emergency, emergency, and open connection to the emergency switch. If no emergency switch is connected or the connection to the emergency switch is broken, the resistive divider R0541/R0512 sets the voltage to about 4.7 volts. If an emergency switch is connected, a resistor to ground within the emergency switch reduces the voltage on line GP5 IN ACC9 to inform the  $\mu\text{P}$  that the emergency switch is operational. An engaged emergency switch pulls line GP5 IN ACC9 to ground level. Diode D0179 limits the voltage to protect the  $\mu\text{P}$  input.

While the EMERGENCY CONTROL signal is low and INT SW B+ is on, the  $\mu\text{P}$  starts execution, reads that the emergency input is active through the voltage level of line GP5 IN ACC9, and sets the DC POWER ON output of the ASFIC CMP, pin 13 to a logic high. This keeps Q0661 and Q0641 switched to allow a momentary press of the emergency switch to power up the radio. When the  $\mu\text{P}$  has finished processing the emergency press, it sets the DC POWER ON line to a logic 0. This turns off Q0661 and the radio turns off. Notice that the  $\mu\text{P}$  is alerted to the emergency condition via line GP5 IN ACC9. If the radio is already on when the emergency is triggered, the DC POWER ON signal is already high.

### 2.2.4 Mechanical On/Off

This refers to the on/off/volume knob located on the control head which is used to turn the radio on and off and control the volume.

If the radio is turned off and the on/off/volume knob is pressed, line ON OFF CONTROL (J0401, pin 11) goes high and switches the radio's voltage regulators on as long as the button is pressed. The  $\mu\text{P}$  is alerted through line ON OFF SENSE (U0101, pin 6) which is pulled to low by Q0110 while the on/off/volume knob is pressed. In addition, an interrupt is generated at  $\mu\text{P}$ , pin 96. The  $\mu\text{P}$  asserts line DC POWER ON via ASFIC CMP, pin 13 high which keeps the radio switched on. The  $\mu\text{P}$  switches the radio off by setting DC POWER ON to low via ASFIC CMP pin 13.

### 2.2.5 Ignition

Ignition sense prevents the radio from draining the vehicle's battery because the engine is not running.

When the IGNITION input (J0501, pin 10) goes above 5 volts, Q0661 is turned on via line IGNITION CONTROL. Q0661 turns on INT SW B+ and the voltage regulators by turning on Q0641 and the  $\mu\text{P}$  starts execution. The  $\mu\text{P}$  is alerted through line GP6 IN ACC10. While the on/off button is pressed, a high signal turns Q0181 on, which pulls  $\mu\text{P}$ , pin 74 to low. If the software detects a low state it asserts DC POWER ON via ASFIC, pin 13 high which keeps Q0661 and Q0641 and the radio switched on.

When the IGNITION input goes below 3 volts, Q0181 switches off and R0181 pulls  $\mu\text{P}$ , pin 74 to high. This alerts the software to switch off the radio by setting DC POWER ON to low. The next time the IGNITION input goes above 5 volts the above process is repeated.

## 2.2.6 Microprocessor Clock Synthesizer

The clock source for the  $\mu$ P system is generated by the ASFIC CMP (U0221). Upon power-up the synthesizer IC (FRAC-N) generates a 16.8 MHz waveform that is routed from the RF section to the ASFIC CMP, pin 34. For the main board controller the ASFIC CMP uses 16.8 MHz as a reference input clock signal for its internal synthesizer. The ASFIC CMP, in addition to the audio circuit, has a programmable synthesizer which can generate a synthesized signal ranging from 1200Hz to 32.769MHz in 1200Hz steps.

When power is first applied, the ASFIC CMP generates its default 3.6864MHz CMOS square wave UP CLK (on U0221, pin 28) and this is routed to the  $\mu$ P (U0101, pin 90). After the  $\mu$ P starts operation, it reprograms the ASFIC CMP clock synthesizer to a higher UP CLK frequency (usually 7.3728 or 14.7456 MHz) and continues operation.

The ASFIC CMP may be reprogrammed to change the clock synthesizer frequencies at various times depending on the software features that are executing. In addition, the clock frequency of the synthesizer is changed in small amounts if there is a possibility of harmonics of this clock source interfering with the desired radio receive frequency.

The ASFIC CMP synthesizer loop uses C0245, C0246 and R0241 to set the switching time and jitter of the clock output. If the synthesizer cannot generate the required clock frequency it switches back to its default 3.6864MHz output.

Because the ASFIC CMP synthesizer and the  $\mu$ P do not operate without the 16.8 MHz reference clock, the synthesizer and the voltage regulators should be checked first in debugging the system.

The  $\mu$ P uses crystal oscillator Y0131 and associated components to form a real time clock used to display the time on control heads (with display) or as time stamp for incoming calls or messages. The real time clock is powered from the voltage VSTBY to keep running while the radio is switched off. If the radio is disconnected from the supply voltage, the time must be reset.

## 2.2.7 Serial Peripheral Interface (SPI)

The  $\mu$ P communicates to many of the IC's through its SPI port. This port consists of SPI TRANSMIT DATA (MOSI) (U0101, pin 100), SPI RECEIVE DATA (MISO) (U0101, pin 99), SPI CLK (U0101, pin 1) and chip select lines going to the various ICs. The BUS is a synchronous bus, in that the timing clock signal CLK is sent while SPI data (SPI TRANSMIT or RECEIVE) is sent. Therefore, whenever there is activity on either SPI TRANSMIT DATA or SPI RECEIVE DATA there should be a uniform signal on CLK.

The SPI TRANSMIT DATA sends serial data from the  $\mu$ P to a device, and SPI RECEIVE DATA is sends data from a device to the  $\mu$ P. On the controller there are two ICs on the SPI BUS: ASFIC CMP (U0221, pin 22), and EEPROM (U0111, pin 5). In the RF section there are two ICs on the SPI BUS: FRAC-N Synthesizer, and the Power Control IC (PCIC). The SPI TRANSMIT DATA and CLK lines going to the RF section are filtered by L0481/R0481 and L0482/R0482 to minimize noise. The chip select line CSX from U0101, pin 2 is shared by the ASFIC CMP, FRAC-N Synthesizer, and PCIC. Each of these IC's check the SPI data and when the sent address information matches the IC's address, the data that follows is processed. The chip select lines for the EEPROM (EE CS), voice storage (VS CS), expansion board (EXP1 CS, EXP2 CS) and option board (OPT CS) are decoded by the address decoder U0141.

When the  $\mu$ P needs to program any of these IC's it brings the chip select line CSX to a logic 0 and then sends the proper data and clock signals. The amount of data sent varies, for example the ASFIC CMP can receive up to 19 bytes (152 bits) while the PCIC can receive up to 6 bytes (48 bits). After the data is sent, the chip select line is returned to logic 1.

The option board interfaces are different in that the  $\mu\text{P}$  can also read data back from devices connected. The timing and operation of this interface is specific to the option connected, but the general pattern is as follows:

- Option board generates a service request via J0551, pin 29, line RDY, and  $\mu\text{P}$ , pin 79
- The main board asserts a chip select for that option board via U0141, pin 14, line OPT CS, J0551, pin 30
- The main board  $\mu\text{P}$  generates the CLK (J0551, pin 3)
- The main board  $\mu\text{P}$  writes serial data via J0551, pin 15 and reads serial data via J0551, pin 16
- When data transfer is complete the main board terminates the chip select and CLK activity

### 2.2.8 SBEP Serial Interface

The SBEP serial interface allows the radio to communicate with the Customer Programming Software (CPS), or the universal tuner via the Radio Interface Box (RIB). This interface connects to the microphone connector via control head connector (J0401, pin 8) or to the accessory connector J0401, pin 17 and comprises BUS+. The line is bi-directional, meaning that either the radio or the RIB can drive the line. The  $\mu\text{P}$  sends serial data via pin 98 and D0101 and it reads serial data via pin 97. Whenever the  $\mu\text{P}$  detects activity on the BUS+ line, it starts communication.

In addition, the SBEP serial interface is used to communicate with a connected control head. When a control head key is pressed or the volume knob is rotated, the line ON OFF CONTROL goes high. This turns on transistor Q0110 which pulls line ON OFF SENSE and  $\mu\text{P}$ , pin 6 to ground level. In addition, an interrupt is generated via R0109 (for SELECT 5 / MDC models) and  $\mu\text{P}$ , pin 96. This indicates that the control head wants to start SBEP communication. The  $\mu\text{P}$  then reads the registers of the Universal Asynchronous Receiver Transmitter (UART) U0125 to determine that the interrupt source was the control head. If the interrupt source was from the control head, the  $\mu\text{P}$  requests the data from the control head. The control head starts sending and after all data has been sent, the ON OFF CONTROL line goes low. The control head ignores any data on BUS+ during SBEP communication with the CPS or universal tuner.

### 2.2.9 General Purpose Input/Output

The controller provides eight general purpose lines (DIG1 through DIG8) available on the accessory connector J0501 to interface the external options. Lines DIG IN 1,3,5,6, are inputs, DIG OUT 2 is an output and DIG IN OUT 4,7,8 are bidirectional. The software and the hardware of the radio model define the function of each port.

DIG IN 1 can be used as external PTT input or others, set by the CPS. The  $\mu\text{P}$  reads this port via pin 77 and Q0171.

DIG OUT 2 can be used as normal output or external alarm output, set by the CPS. Transistor Q0173 is controlled by the  $\mu\text{P}$  via ASFIC CMP, pin 14.

DIG IN 3 is read by  $\mu\text{P}$ , pin 63 via resistor R0176

DIG IN 5 can be used as normal input or emergency input, set by the CPS. The  $\mu\text{P}$  reads this port via R0179 and  $\mu\text{P}$ , pin 60. Diode D0179 limits the voltage to protect the  $\mu\text{P}$  input.

DIG IN 6 can be used as normal input, set by the CPS. The  $\mu\text{P}$  reads this port via, pin 74 and Q0181.

DIG IN OUT 4,7,8 are bidirectional and use the same circuit configuration. Each port uses an output transistor Q0177, Q0183, Q0185 controlled by  $\mu\text{P}$ , pins 46, 47, 53. The ports are read by  $\mu\text{P}$ , pins 75, 54, 76. To use one of the ports as input the  $\mu\text{P}$  must turn off the corresponding output transistor.

In addition the signals from DIG IN 1, DIG IN OUT 4 are fed to the option board connector J0551 and the expansion board connector J0451.

### 2.2.10 Normal Microprocessor Operation

The  $\mu\text{P}$  is configured to operate in one of two modes: expanded or bootstrap. In expanded mode, the  $\mu\text{P}$  uses external memory devices to operate. In bootstrap mode, the  $\mu\text{P}$  uses only its internal memory.

During normal operation of the radio, the  $\mu\text{P}$  is operating in expanded mode and the  $\mu\text{P}$  (U0101) has access to three external memory devices: U0121 (EEPROM), U0122 (SRAM), and U0111 (EEPROM). Also, within the  $\mu\text{P}$  there are three KBs of internal RAM, as well as logic to select external memory devices.

The external EEPROM (U0111) space contains the information in the radio which is customer specific, referred to as the codeplug. This information consists of items such as:

- Band in which the radio operates
- What frequencies are assigned to what channel
- Tuning information.

The external SRAM (U0122) as well as the  $\mu\text{P}$ 's own internal RAM space are used for temporary calculations required by the software during execution. All of the data stored in both of these locations is lost when the radio powers off (See the particular device subsection for more details).

The  $\mu\text{P}$  provides an address bus of 16 address lines (ADDR 0 - ADDR 15), and a data bus of eight data lines (DATA 0 - DATA 7). There are also three control lines: CSPROG (U0101, pin 38) to chip select U0121, pin 30 (EEPROM), CSGP2 (U0101, pin 41) to chip select U0122, pin 20 (SRAM) and PG7 R W (U0101, pin 4) to select whether to read or to write. The external EEPROM (U0111, pin 1), the OPTION BOARD and EXPANSION BOARD are selected by three lines of the  $\mu\text{P}$  using address decoder U0141. The chips ASFIC CMP / FRAC-N / PCIC are selected by line CSX (U0101, pin 2).

When the  $\mu\text{P}$  is functioning normally, the address and data lines are toggling at CMOS logic levels. Specifically, the logic high levels should be between 4.8 to 5.0 volts, and the logic low levels should be between 0 to 0.2 volts. No other intermediate levels should be observed, and the rise and fall times should be  $<30\text{ns}$ .

The low-order address lines (ADDR 0 - ADDR 7) and the data lines (DATA 0-DATA 7) should be toggling at a high rate, e. g., you should set your oscilloscope sweep to  $1\mu\text{s}/\text{div}$ . or faster to observe individual pulses. High speed CMOS transitions should also be observed on the  $\mu\text{P}$  control lines. On the  $\mu\text{P}$  the lines XIRQ (U0101, pin 48), MODA LIR (U0101, pin 58), MODB VSTPY (U0101, pin 57) and RESET (U0101, pin 94) should be high at all times during normal operation. Whenever a data or address line becomes open or shorted to an adjacent line, a common symptom is that the RESET line goes low periodically, with the period being in the order of 20msecs. In the case of shorted lines you may also detect the line periodically at an intermediate level, i.e. around 2.5 volts when two shorted lines attempt to drive to opposite rails.

The MODA LIR (U0101, pin 58) and MODB VSTPY (U0101, pin 57) inputs to the  $\mu\text{P}$  must be at a logic 1 for it to start executing correctly. After the  $\mu\text{P}$  starts execution it periodically pulses these lines to determine the desired operating mode. While the central processing unit (CPU) is running, MODA LIR is an open-drain CMOS output which goes low whenever the  $\mu\text{P}$  begins a new instruction. One instruction typically requires 2-4 external bus cycles, or memory fetches.

There are eight analog-to-digital converter ports (A/D) on U0101 labelled within the device block as PE0-PE7. These lines sense the voltage level ranging from 0 to 5V of the input line and convert that level to a number ranging from 0 to 255 which is read by the software to take appropriate action.

For example U0101, pin 67 is the battery voltage detect line. R0671 and R0672 form a resistor divider on INT SWB+. With 30K and 10K and a voltage range of 11V to 17V, that A/D port is 2.74V to 4.24V which is then be converted to  $\sim 140$  to 217 respectively.

U0101-69 is the high reference voltage for the A/D ports on the  $\mu$ P. Capacitor C0101 filters the +5 volt reference. If this voltage is lower than +5 volt, the A/D reading is incorrect. Likewise U0101, pin 68 is the low reference for the A/D ports. This line is normally tied to ground. If this line is not connected to ground, the A/D readings could be incorrect.

### 2.2.11 Static Random Access Memory (SRAM)

The SRAM (U0121) contains temporary radio calculations or parameters that can change very frequently, and which are generated and stored by the software during its normal operation. The information is lost when the radio is turned off.

The device allows an unlimited number of write cycles. SRAM accesses are indicated by the CS signal U0122, pin 20 which is the result of U0101-CSGP2 going low. U0122 is commonly referred to as the external RAM as opposed to the internal RAM which is the 3 KBs of RAM (part of the 68HC11FL0). Both RAM spaces serve the purpose. However, the internal RAM is used for the calculated values which are accessed most often.

Capacitor C0122 filters out any ac noise which may ride on +5V at U0122.

## 2.3 Controller Board Audio and Signalling Circuits

### 2.3.1 Audio Signalling Filter IC with Compander (ASFIC CMP)

The ASFIC CMP (U0221) used in the controller has the four following functions:

- RX/TX audio shaping, i.e. filtering, amplification, attenuation
- RX/TX signalling, PL/DPL/HST/MDC
- Squelch detection
- $\mu$ P clock signal generation

The ASFIC CMP is programmable through the SPI BUS (U0221-20/21/22), normally receiving 19 bytes. This programming sets up various paths within the ASFIC CMP to route audio and/or signalling signals through the appropriate filtering, gain, and attenuator blocks. The ASFIC CMP also has six general control bits (GCB0-5) which are CMOS level outputs and used for NOISE BLANKER (GCB0) in low band radios, EXTERNAL ALARM (GCB1), and DC POWER ON (GCB2) to switch the voltage regulators (and the radio) on and off. GCB3 controls U0251, pin 11 to output either RX FLAT AUDIO or RX FILTERED AUDIO on the accessory connector, pin 11. GCB4 controls U0251, pin 10 to use either the external microphone input or the voice storage playback signal. GCB5 switches the audio PA on and off.

## 2.3.2 Transmit Audio Circuits

Refer to Figure 2-3 for the descriptions that follow.

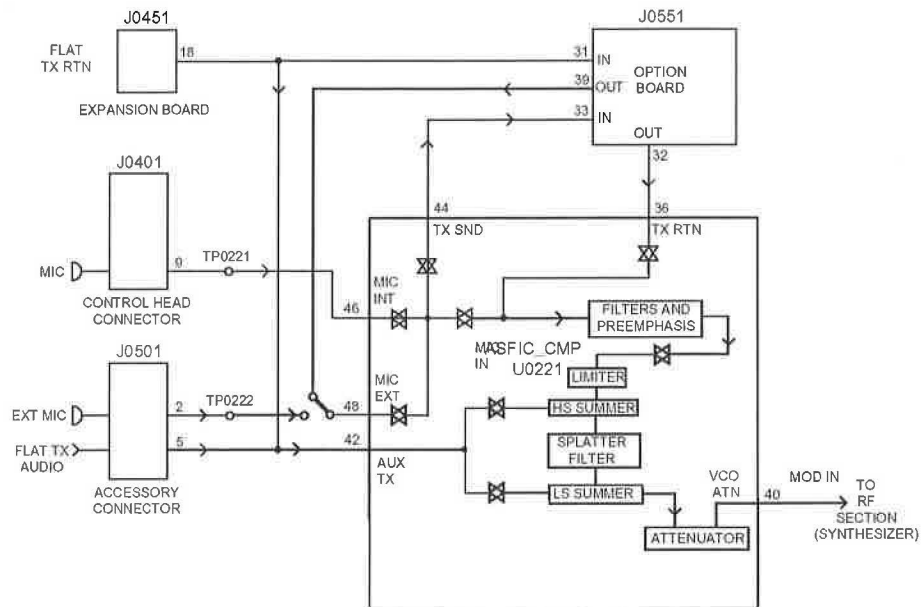

Figure 2-3. Transmit Audio Paths

## 2.3.3 Microphone Input Path

The radio supports two microphone input paths. One from the control head external microphone accessory connector J0501, pin 2, and one from the microphone auxiliary path (FLAT TX AUDIO) via accessory connector J0501, pin 5. The microphones require a DC biasing voltage provided by a resistive network.

The two microphone audio input paths enter the ASFIC CMP at U0221, pin 48 (external microphone) and U0221, pin 46 (auxiliary microphone).

The microphone is plugged into the radio control head which is connected to the controller board via J0401, pin 9. The signal is then routed via R0409 and line INT MIC to R0205. Resistors R0201 and R0202 provide 9.3Vdc bias. Resistive divider R0205/R0207 divide the input signal by 5.5 and provide input protection for the CMOS amplifier input. R0202 and C0201 provide a 560 ohm AC path to ground that sets the input impedance for the microphone and determines the gain based on the emitter resistor in the microphone's amplifier circuit.

Capacitor C0204 provides dc blocking. The audio signal at U0221, pin 46 (TP0221) is approximately 14mV for 1.5kHz deviation.

The external microphone signal enters the radio on accessory connector J0501, pin 5, then it is routed via line EXT MIC to resistor R0206. Resistors R0201 and R0204 provide a 9.3Vdc bias. Resistive divider R0206 / R0208 divide the input signal by 5.5 and provide input protection for the CMOS amplifier input. R0204 and C0201 provide a 560 ohm AC path to ground that sets the input impedance for the microphone and determines the gain based on the emitter resistor in the microphone's amplifier circuit. Capacitor C0254 provides dc blocking.

Multi switch U0251 controlled by ASFIC CMP port GCB4 selects either the external microphone input signal or the voice storage playback signal for entering the ASFIC CMP at pin 48. The audio signal at U0221-48 (TP0222) is approximately 14mVrms for 1.5kHz deviation with 12.5kHz channel spacing.

The FLAT TX AUDIO signal from accessory connector J0501-5 is fed to the ASFIC CMP (U0221, pin 42) through C0541 and line FLAT TX RTN.

The ASFIC has an internal AGC that controls the gain in the microphone audio path. The AGC can be disabled/enabled by the  $\mu$ P. Another feature that can be enabled/disabled in the ASFIC is the VOX. This circuit, along with the capacitor at U0221, pin 7, provides a dc voltage allows the  $\mu$ P to detect microphone audio. The ASFIC can also be programmed to route the microphone audio to a speaker for public address operation.

### **2.3.3.1 PTT Sensing and TX Audio Processing**

The microphone PTT signal coming from the control head is sent via the SBEP bus to the  $\mu$ P. An external PTT can be generated by grounding pin 3 on the accessory connector if this input is programmed for PTT by the CPS. When microphone PTT is sensed, the  $\mu$ P always configures the ASFIC CMP for the "internal" microphone audio path, and external PTT results in the external microphone audio path being selected.

Inside the ASFIC CMP, the microphone audio is filtered to eliminate frequency components outside the 300-3000Hz voice band, and pre-emphasized if pre-emphasis is enabled. The signal is then limited to prevent the transmitter from over deviating. The limited microphone audio is then routed through a summer, which is used to add in signalling data, and then to a splatter filter to eliminate high frequency spectral components that could be generated by the limiter. The audio is then routed to an attenuator, which is tuned in the factory or the field to set the proper amount of FM deviation. The TX audio emerges from the ASFIC CMP at U0221-40 MOD IN, at which point it is routed to the RF section.

### **2.3.3.2 TX Secure Audio (optional)**

The audio follows the normal transmit audio processing until it emerges from the ASFIC CMP TX SND pin (U0221-44), which is fed to the Secure board residing at option connector J0551-33. The Secure board contains circuits to amplify, encrypt, and filter the audio. The encrypted signal is then fed back from J0551-32 to the ASFIC CMP TX RTN input (U0221-36). The signal level at this pin should be about 65mVrms. The signal is then routed through the TX path in the ASFIC CMP and emerges at MOD IN pin 40.

### **2.3.3.3 Option Board Transmit Audio**

The audio follows the normal transmit audio processing until it emerges from the ASFIC CMP TX SND pin (U0221-44), which is fed to the option board residing at option connector J0551-33. The option board contains circuits to process the audio. The processed signal is then fed back from J0551-32 to the ASFIC CMP TX RTN input (U0221-36). The signal level at this pin is approximately 65mVrms. The signal is then routed through the TX path in the ASFIC CMP and out at MOD IN, pin 40.



### 2.3.4 Transmit Signalling Circuits

Refer to Figure 2-4 for the descriptions that follow.

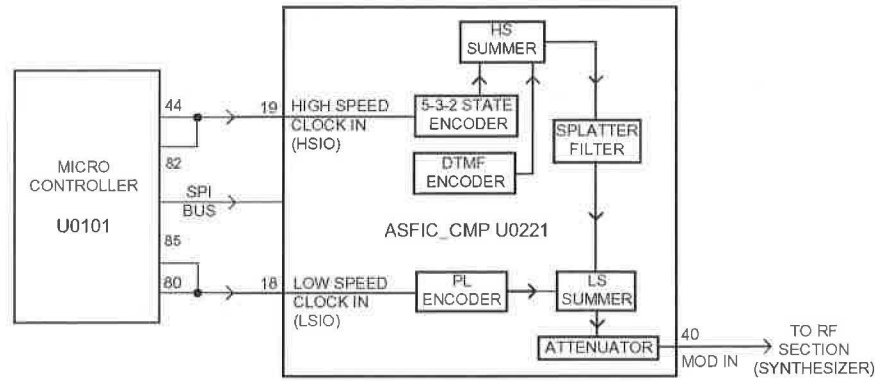

**Figure 2-4.** Transmit Signalling Paths

The three types of transmit signalling paths are as follows:

- Sub-audible data (PL/DPL/connect tone) summed with transmit voice or signalling
- DTMF data for telephone communication between trunked and conventional systems
- Audible signalling

**Note:** All three types are supported by the hardware while the radio software determines which signalling type is available.

#### 2.3.4.1 Sub-Audible Data (PL/DPL)

Sub-audible data implies signalling whose frequency/data rate is below 300Hz. PL and DPL waveforms are used for conventional operation and connect tones for trunked voice channel operation. The trunking connect tone is simply a PL tone at a higher deviation level than PL in a conventional system. Although it is referred to as "sub-audible data," the actual frequency spectrum of these waveforms may be as high as 250 Hz, which is audible to the human ear. However, the radio receiver filters out any audio below 300Hz, so these tones are never heard in the actual system.

Only one type of sub-audible data can be generated by U0221 (ASFIC CMP) at any one time. The process is as follows, using the SPI BUS, the  $\mu$ P programs the ASFIC CMP to set up the proper low-speed data deviation and select the PL or DPL filters. The  $\mu$ P then generates a square wave which strobes the ASFIC PL / DPL encode input LSIO U0221-18 at twelve times the desired data rate. For example, for a PL frequency of 103Hz, the frequency of the square wave is 1236Hz.

This drives a tone generator inside U0221 which generates a staircase approximation to a PL sine wave or DPL data pattern. This internal waveform is then low-pass filtered and summed with voice or data. The resulting summed waveform then appears on U0221-40 (MOD IN), where it is sent to the RF board as previously described for transmit audio. A trunking connect tone would be generated in the same manner as a PL tone.

### **2.3.4.2 High Speed Data**

High speed data refers to the 3600 baud data waveforms, known as inbound signalling words (ISWs) used in a trunking system for high speed communication between the central controller and the radio. To generate an ISW, the  $\mu$ P first programs the ASFIC CMP (U0221) to the proper filter and gain settings. It then begins strobing U0221-19 (HSIO) with a pulse when the data is supposed to change states. U0221's 5-3-2 state encoder, which is in a 2-state mode, is then fed to the post-limiter summer block and then the splatter filter. From that point, it is routed through the modulation attenuators and then out of the ASFIC CMP to the RF board. MPT 1327 and MDC are generated in much the same way as trunking ISW. However, in some cases these signals may also pass through a data pre-emphasis block in the ASFIC CMP. Also these signalling schemes are based on sending a combination of 1200 Hz and 1800 Hz tones only. Microphone audio is muted during high speed data signalling.

### **2.3.4.3 Dual Tone Multiple Frequency (DTMF) Data**

DTMF data is a dual tone waveform used during phone interconnect operation. It is the same type of tones which are heard when using a "Touch Tone" telephone.

There are seven frequencies, with four in the low group (697, 770, 852, 941Hz) and three in the high group (1209, 1336, 1477Hz).

The high-group tone is generated by the  $\mu$ P (U0101-44) strobing U0221-19 at six times the tone frequency for tones less than 1440Hz or twice the frequency for tones greater than 1440Hz. The low group tone is generated by the ASFIC CMP, controlled by the  $\mu$ P via SPI bus. Inside U0221 the low-group and high-group tones are summed (with the amplitude of the high group tone being approximately 2 dB greater than that of the low group tone) and then pre-emphasized before being routed to the summer and splatter filter. The DTMF waveform then follows the same path as described for high-speed data

## 2.3.5 Receive Audio Circuits

Refer to Figure Figure 2-5 for the descriptions that follow.

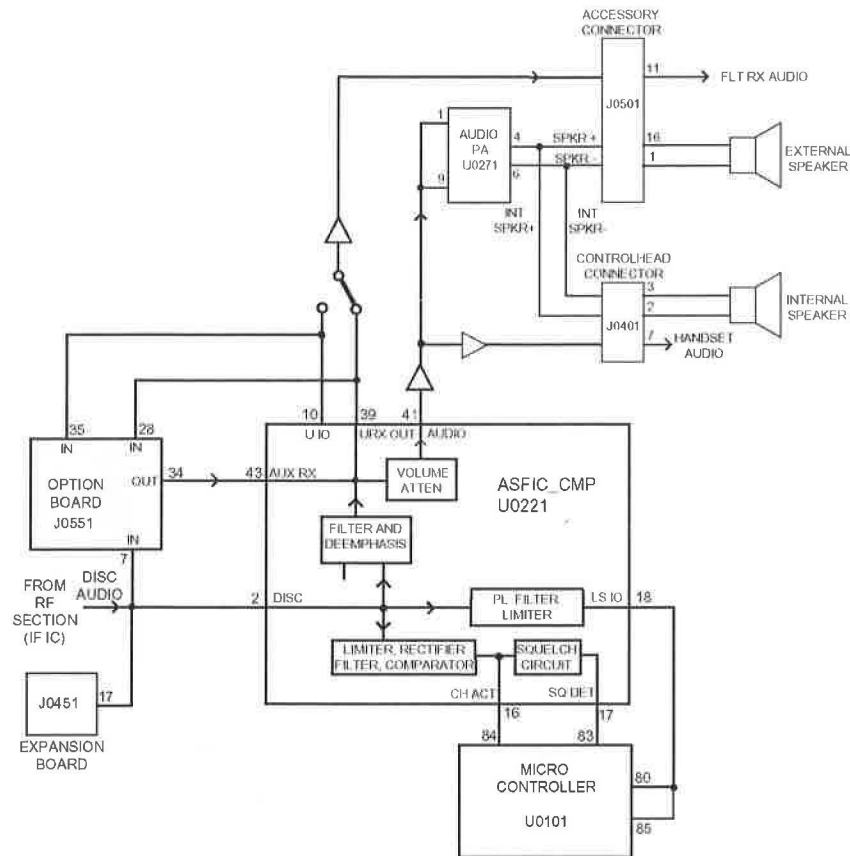

Figure 2-5. Receive Audio Paths

### 2.3.5.1 Squelch Detect

The squelch detect circuits are all contained within the ASFIC CMP as shown in Figure 2-5. The radio's RF circuits are constantly producing an output (DISC AUDIO) at the discriminator IF IC. The output signal is applied to the ASFIC CMP's squelch detect circuits DISC input (U0221, pin 2). The squelch signal entering the ASFIC CMP is amplified, filtered, attenuated, and rectified. It is then sent to a comparator to produce an active high signal (CH ACT). The squelch circuit produces the SQ DET signal at U0221, pin 17 from the CH ACT input signal. The state of CH ACT and SQ DET go from a low (logic 0) to a high (logic 1) when an RF carrier is detected. The CH ACT and SQ DET signals from the squelch circuit are applied to the  $\mu$ P pins 84 and 83 respectively.

SQ DET is used to determine all audio mute/unmute decisions except for conventional scan. In this case CH ACT is a pre-indicator as it occurs slightly faster than SQ DET.

### 2.3.5.2 Audio Processing and Digital Volume Control

The receiver audio signal (DISC AUDIO) enters the controller section from the IF IC where it is AC coupled by C0227 before entering the ASFIC CMP via the DISC input at U0221, pin 2. The signal is then applied to both the audio and the PL/DPL paths.

The signal on the audio path is applied to a programmable amplifier, whose setting is based on the channel bandwidth being received, an LPF filter to remove any frequency components above 3000Hz, and HPF filter to strip off any sub-audible data below 300Hz. The recovered audio passes through a de-emphasis filter, if it is enabled, to compensate for pre-emphasis which is used to reduce the effects of FM noise. The audio then goes through the 8-bit programmable attenuator whose level is set depending on the value of the volume control. The resulting filtered audio signal is passed through an output buffer within the ASFIC CMP and exits the ASFIC CMP at the AUDIO output (U0221, pin 41).

The  $\mu$ P programs the attenuator, using the SPI BUS, based on the volume setting. The minimum/maximum settings of the attenuator are set by codeplug parameters.

Since sub-audible signalling is summed with voice information on transmit, it must be separated from the voice information before processing. Any sub-audible signal enters the ASFIC CMP from the IF IC at DISC U0221, pin 2, then through the PL/DPL path. The signal first passes through one of two low pass filters, either PL low pass filter, or DPL/LST low pass filter. Either signal is then filtered, goes through a limiter, and exits the ASFIC CMP at LSIO (U0221, pin 18). At this point the signal appears as a square wave version of the sub-audible signal the radio received. The  $\mu$ P (U0101, pin 80) decodes the signal directly to determine if it is the tone/code currently active on that mode.

### **2.3.5.3 Audio Amplification Speaker (+) Speaker (-)**

The output of the ASFIC CMP's digital volume pot (U0221, pin 41) is routed through dc blocking capacitor C0256 to a buffer formed by U0211, pin 1. Resistors R0256 and R0268 set the correct input level to the audio PA (U0271). This is necessary because the gain of the audio PA is 46 dB and the ASFIC CMP output is capable of overdriving the PA unless the maximum volume is limited. Resistor R0267 and capacitor C0267 increase frequency components below 350 Hz.

The audio then passes through R0269 and C0272 which provides AC coupling and low frequency roll-off. C0273 provides high frequency roll-off as the audio signal is routed to audio power amplifier U0271, pins 1 and 9 which are both tied to the received audio. The audio power amplifier has one inverted and one non-inverted output that produces the differential audio output SPK+/SPK- (U0271, pins 4 and 6).

The audio PA's dc biases are not activated until the audio PA is enabled at pin 8. The audio PA is enabled via the ASFIC CMP (U0221, pin 38). When the base of Q0271 is low, the transistor is off and U0271-8 is high via pull-up resistor R0273, and the audio PA is ON. The voltage at U0273-8 must be above 8.5Vdc to properly enable the device. If the voltage is between 3.3 and 6.4V, the device is active, but has its input (U0273, pins 1 and 9) off. This is a mute condition used to prevent an audio pop when the PA is enabled.

The SPK+ and SPK- outputs of the audio PA are dc biased and vary proportionately with FLT A+ (U0271, pin 7). FLT A+ of 11V yields a dc offset of 5V, and FLT A+ of 17V yields a dc offset of 8.5V. If either of these lines is shorted to ground, it is possible that the audio PA could be damaged. SPK+ and SPK- are routed to the accessory connector (J0501, pins 1 and 16) and to the control head connector (J0401, pins 2 and 3).

### **2.3.5.4 Handset Audio**

Certain accessories have a self contained speaker which requires a different voltage level than that provided by U0271. For those devices, HANDSET AUDIO is available at control head connector J0401, pin 7.

The received audio from the output of the ASFIC CMP's digital volume attenuator and buffered by U0211, pin 1, is also routed to U0211, pin 9 where it is amplified by 20 dB. This is set by the 10k/100k combination of R0261 and R0262. This signal is routed from the output of the op amp U0211 to J0401-7. The control head sends this signal directly out to the microphone jack. The maximum value of this output is 6.6Vp-p.

### **2.3.5.5 Filtered Audio and Flat Audio**

The ASFIC CMP audio output at U0221, pin 39 is filtered and de-emphasized, but has not yet gone through the digital volume attenuator. From ASFIC CMP U0221, pin 39 the signal is routed via R0251 through gate U0251, pin 12 and AC coupled to U0211, pin 2. The gate controlled by ASFIC CMP port GCB3 (U0221, pin 35) selects between the filtered audio signal from the ASFIC CMP at pin 39 (URXOUT) or the unfiltered flat audio signal from the ASFIC CMP, U10, pin 10. Resistors R0251 and R0253 determine the gain of op amp U0211, pin 2 for the filtered audio while R0252 and R0253 determine the gain for the flat audio. The output of U0253, pin 7 is then routed to J0501, pin 11 via dc blocking capacitor C0542. Note that any volume adjustment of the signal on this path must be done by the accessory.

### **2.3.5.6 RX Secure Audio Option**

Discriminator audio, which is now encrypted audio, follows the normal receive audio processing until it is output from the ASFIC CMP UIO (U0221, pin 10), which is fed to the secure audio board at option connector J0551, pin 35. On the secure board, the encrypted signal is converted back to normal audio format, then fed back through J0551, pin 34 to AUX RX of the ASFIC CMP (U0221, pin 43). The signal then follows a path identical to the conventional receive audio, where it is filtered (0.3 - 3kHz) and deemphasized. The signal URX SND from the ASFIC CMP (U0221-39) also routed to option connector J0551, pin 28, is not used for the secure board, but for other option boards.

### **2.3.5.7 Option Board Receive Audio**

Unfiltered audio from the ASFIC CMP (U0221, pin 10) enters the option board at connector J0551, pin 35. Filtered audio from the ASFIC CMP URXOUT (U0221, pin 39) enters the option board at connector J0551, pin 28. On the option board, the signal is processed, then fed back through (J0551, pin 34) to AUX RX of the ASFIC CMP (U0221, pin 43). The signal then follows a path identical to conventional receive audio, where it is filtered (0.3 - 3kHz) and de-emphasized.

## 2.3.6 Receive Signalling Circuits

Refer to Figure Figure 2-6 for the descriptions that follow.

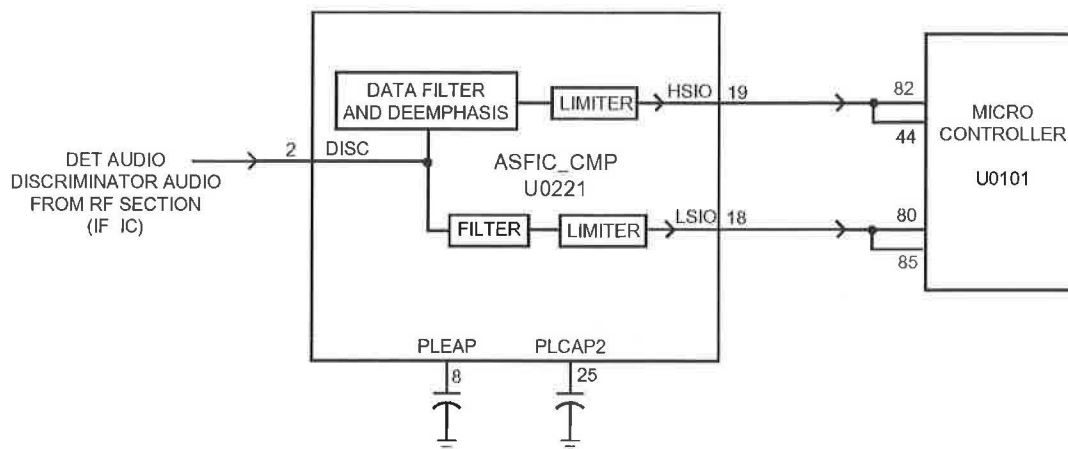

Figure 2-6. Receive Signalling Paths

### 2.3.6.1 Sub-Audible Data (PLIDPL) and High Speed Data Decoder

The ASFIC CMP (U0221) filters and limits all received data. The data enters the ASFIC CMP at input DISC (U0221, pin 2). Inside U0221 the data is filtered according to data type (HS or LS), then it is limited to a 0-5V digital level. The MDC and trunking high speed data appear at U0221, pin 19, where it connects to the  $\mu$ P U0101, pin 82

The low speed limited data output (PL, DPL, and trunking LS) appears at U0221, pin 18, where it connects to the  $\mu$ P U0101, pin 80.

The low speed data is read by the  $\mu$ P at twice the frequency of the sampling waveform; a latch configuration in the ASFIC CMP stores one bit every clock cycle. The external capacitors C0236, and C0244 set the low frequency pole for a zero crossings detector in the limiters for PL and HS data. The hysteresis of these limiters is programmed based on the type of received data.

### 2.3.6.2 Alert Tone Circuits

When the software determines that it needs to give the operator an audible feedback for a good key press, or for a bad key press, or radio status (trunked system busy, phone call, circuit failures), it sends an alert tone to the speaker. It does so by sending SPI BUS data to U0221 which sets up the audio path to the speaker for alert tones. The alert tone itself can be generated in one of two ways: internally by the ASFIC CMP, or externally using the  $\mu$ P and the ASFIC CMP.

The allowable internal alert tones are 304, 608, 911, and 1823Hz. In this case a code contained within the SPI BUS load to the ASFIC CMP sets up the path and determines the tone frequency, and at what volume level to generate the tone. (It does not have to be related to the voice volume setting).

For external alert tones, the  $\mu$ P can generate any tone within the 100-3000Hz audio band. This is accomplished by the  $\mu$ P generating a square wave which enters the ASFIC CMP at U0221-19. Inside the ASFIC CMP this signal is routed to the alert tone generator

The output of the generator is summed into the audio chain just after the RX audio de-emphasis block. Inside U0221 the tone is amplified and filtered, then passed through the 8-bit digital volume attenuator, which is typically loaded with a special value for alert tone audio. The tone exits at U0221-41 and is routed to the audio PA like receive audio.

### 2.3.6.3 Voice Storage Option

The Voice Storage (VS) can be used to store audio signals coming from the receiver or from the microphone. Any stored audio signal can be played back over the radio's speaker or sent out via the radio's transmitter.

The PTCB hosts the Voice Storage circuitry. Voice Storage IC U611 provides all the required functionality and is powered from the regulated 3.3 volts from U610. The  $\mu$ P controls U611 via SPI bus lines CLK (U611-8), DATA (U611-10) and MISO (U611-11). To transfer data, the  $\mu$ P first selects the U611 via line VS CS and U611 pin 9. Then the  $\mu$ P sends data through line DATA and receives data through line MISO. Pin 2 (RAC) of U611 indicates the end of a message row by a low state for 12.5 ms and connects to  $\mu$ P pin 65. A low at pin 5 (INT), which is connected to  $\mu$ P pin 55, indicates that the Voice Storage IC requires service from the  $\mu$ P.

Audio, either from the radio's receiver or from one of the microphone inputs, emerges from the ASFIC CMP (U404) at pin 43, through switch U608-1 that is selected by the  $\mu$ P via ASFIC CMP pin 5 (DACR) and then enters the voice storage IC U611 at pin 25. During playback, the stored audio emerges from U611 at pin 20. To transmit the audio signal, it is fed through resistive divider R657 / R658, through switch U608-3 and through line EXT MIC. When this path is selected, the audio signal enters the ASFIC CMP at pin 48 and is processed like normal transmit audio. To play the stored audio over the radio's speaker, the audio from U611 pin 20 is buffered by op-amp U605-1, through switch U608-2 and fed via line FLAT RX SND to ASFIC CMP pin 10 (UIO). In this case, this ASFIC CMP pin is programmed as input and feeds the audio signal through the normal receiver audio path to the speaker or handset. Switches U608-2 and U608-3 are controlled by the  $\mu$ P via ASFIC CMP pin 6 (DACG) and feed the stored audio only to the ASFIC CMP port UIO when it is programmed as input.

## 2.4 200 MHz Receiver Front-End

The 200 MHz receiver design covers the frequency range of 217 to 222 MHz and is separated into two blocks, the front end and the back end. The overall block diagram of the receiver is shown in Figure 2-11. Detailed descriptions of these stages are contained in the paragraphs that follow.

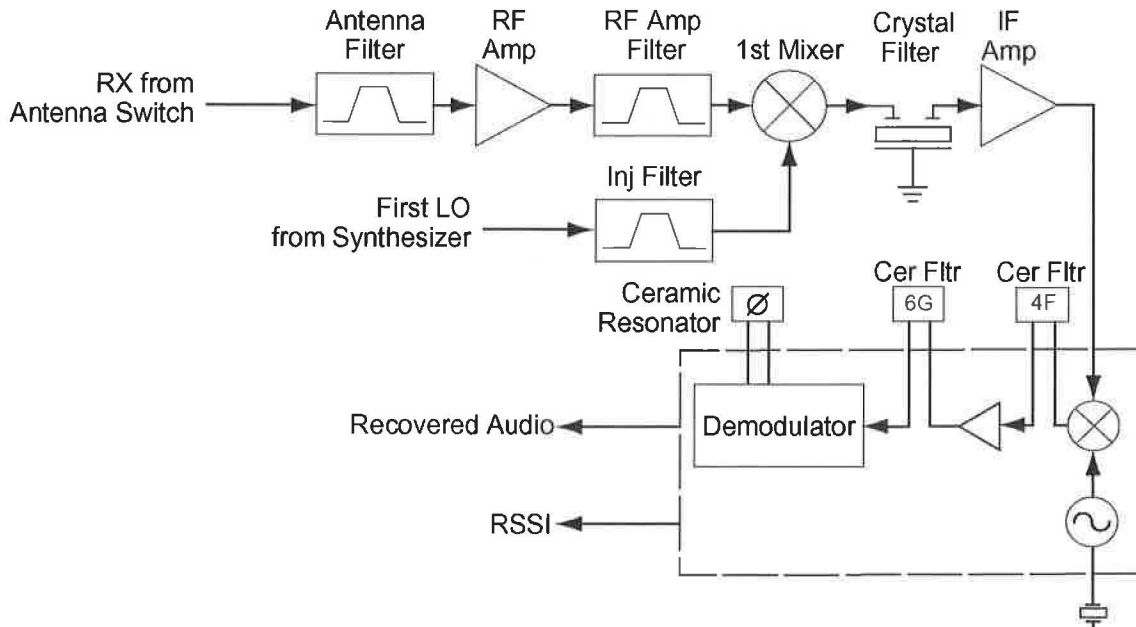

Figure 2-7. 200 MHz Receiver Block Diagram

### 2.4.1 Receiver Front End

The received signal from the antenna is routed through the harmonic filter and antenna switch and applied to the antenna filter, consisting of L320-22 and C3040-47. This fixed-tuned 3-pole bandpass filter is configured to provide steeper attenuation above the passband for improved spurious rejection when high-side first injection is used. The output of this filter is coupled to RF amplifier Q3002. Diode CR3003 protects the RF amplifier by limiting excessive RF levels. Current mirror Q3003 maintains constant current operation of the RF amp vs. device and temperature variations, for optimum dynamic range and noise figure.

The output of the RF amplifier is applied to the RF amp filter comprised of L3023-4, L3041, C3052-7 and C3359, also a fixed-tuned 3-pole bandpass filter configured to provide steeper high-side attenuation. The antenna filter and RF amp filter have a combined 3 dB bandwidth of 24 MHz and utilize 2% inductors and 1% capacitors for accurate and repeatable passband response.

The output of the RF amp filter is routed through a switchable local-distance attenuator consisting of R3099, D3090, Q3090 and associated components. Normally Q3090 and D3090 are on and the receiver sensitivity is at maximum. When Q3090 and D3090 are off, the series resistor R3099 reduces receiver sensitivity to minimize intermodulation when operating in the presence strong undesired signals. The output of the local-distance attenuator is connected to the passive double-balanced mixer consisting of components T3001, T3002, and CR3001. High-side injection from the frequency synthesizer is lowpass filtered by C3073-6, C3081, and L3027-8 to remove second harmonic energy which may degrade half-IF spurious rejection performance, and applied to T3002 at a level of +19 dBm.



The IF output from T3301 is applied to a diplexer (L3025, C3061, R3032, L3181) which matches the 44.85 MHz IF signal to the crystal filter and terminates the mixer into 50Ω at all other frequencies.

## 2.4.2 Receiver Back End

The receiver back end is a dual conversion design. High IF selectivity is provided by FL3101, a 4-pole fundamental mode 44.85 MHz crystal filter with a minimum 3 dB bandwidth of 7.5 kHz. The output is fed to IF amplifier stage Q3110, whose input impedance is adjusted using feedback to provide a proper terminating impedance for the filter. The output of Q3110 is applied to the input of the receiver IFIC U3101. Diode CR3200 prevents overdriving the IFIC.

The IFIC is a low-voltage monolithic FM IF system incorporating a mixer/oscillator, two limiting IF amplifiers, quadrature detector, logarithmic received signal strength indicator (RSSI), voltage regulator and audio and RSSI op amps. The second LO frequency is determined by Y3100. Additional IF selectivity is provided by two ceramic filters, Y3104 (between the second mixer and IF amp) and FL3106 (between the IF amp and the limiter input). Y3104 is a 4 element filter with a BW6 = 12 kHz. FL3106 is a 6 element filter with a BW6 = 9 kHz. These bandwidths are optimum for 12.5 kHz channel spacing systems. Ceramic resonator Y3102 provides phase vs. frequency characteristic required by the quadrature detector, with 90 degree phase shift occurring at 455 kHz. Buffer Q3111 provides a lower driving impedance from the limiter to the resonator, improving the IF waveform and lowering distortion.

## 2.5 Transmitter Power Amplifier (PA) 25 W

The radio's 25 W PA is a three-stage amplifier used to amplify the output from the VCOBIC to the radio transmit level. The line-up consists of three stages which utilize LDMOS technology. The gain of the first stage (U3401) is adjustable, controlled by pin 4 of PCIC (U3501) via U3402-1 (VCNTRL). It is followed by an LDMOS pre-driver stage (Q3421) and an LDMOS final stage (Q3441).

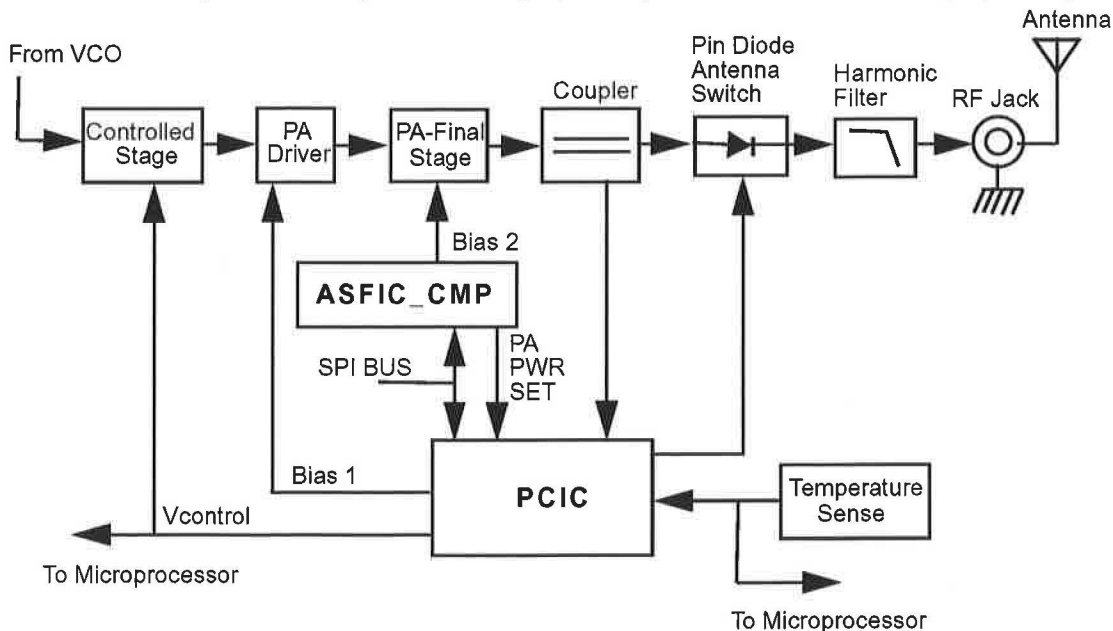

Figure 2-8. 200 MHz Transmitter Block Diagram

Devices U3401 and Q3421 are surface mounted. Q3441 is directly attached to the heat sink.

### 2.5.1 Power Controlled Stage

The first stage (U3401) is a 20 dB gain integrated circuit containing two LDMOS FET amplifier stages. It amplifies the RF signal from the VCO (TXINJ). The output power of stage U3401 is controlled by a dc voltage applied to pin 1 from the power control circuit (U3501 pin 4, with U3402 providing current gain and level-shifting). The control voltage simultaneously varies the bias of two FET stages within U3401. This biasing point determines the overall gain of U3401 and therefore its output drive level to Q3421, which in turn controls the output power of the PA.

In receive mode the voltage control line is at ground level which switches off the biasing voltage to U3401.

### 2.5.2 Pre-Driver Stage

The next stage is an LDMOS device (Q3421) providing a gain of +13 dB. This device requires a positive gate bias and a quiescent current flow for proper operation. The voltage of the line PCIC\_MOSBIAS\_1 is set during transmit mode by the PCIC pin 24, and fed to the gate of Q3421 via the resistive network R3415-16. The bias voltage is factory tuned.

### 2.5.3 Final Stage

The following stage is an enhancement-mode N-Channel MOSFET device (Q3441) providing a gain of 10 dB. This device also requires a positive gate bias and a quiescent current flow for proper operation. The voltage of the line MOSBIAS\_2 is set in transmit mode by the ASFIC and fed to the gate of Q3441 via the resistive network R3404, R3406, and R3431-5. This bias voltage is also tuned in the factory. If the transistor is replaced, the bias voltage must be tuned using the Customer Programming Software (CPS). Care must be taken not to damage the device by exceeding the maximum allowed bias voltage. The device's drain current is drawn directly from the radio's dc supply voltage input, PASUPVLTG, via L3437.

A matching network consisting of C3441-2, C3445-6, and L3443 and two striplines, transforms the impedance to approximately 50 ohms and feeds the directional coupler.

### 2.5.4 Directional Coupler

The directional coupler is a microstrip printed circuit, which couples a small amount of the forward and reflected power delivered by Q3441. The coupled signals are rectified by D3451. The resulting dc voltage is proportional to RF output power and feeds the RFIN port of the PCIC (U3501, pin 1). The PCIC controls the gain of stage U3401 as necessary to hold this voltage constant, thus ensuring the forward power out of the radio to be held to a constant value.

An abnormally high reflected power level, such as may be caused by a damaged antenna, also causes the dc voltage applied to the PCIC to increase, and this will cause a reduction in the gain of U3401, reducing transmitter output power to prevent damage to the final device due to an improper load.

### 2.5.5 Antenna Switch

The antenna switch consists of two PIN diodes, D3471 and D3472. In the receive mode, both diodes are off. Signals applied at the antenna jack J3401 are routed, via the harmonic filter, through network L3472, C3474 and C3475, to the receiver input. In the transmit mode, the keyed A+ turns on Q3471 which enables current sink Q3472, set to 96 mA by R3473 and VR3471. This completes a dc path from PASUPVLTG, through L3437, L3443, D3471, L3472, D3472, L3471, R3474 and the current sink, to ground. Both diodes are forward biased into conduction. The transmitter RF from the directional coupler is routed via D3471 to the harmonic filter and antenna jack. D3472 also conducts, shunting RF power and preventing it from reaching the receiver port (RXIN). L3472 is selected to appear as a broadband quarter-wave transmission line, making the short circuit presented by D3472 appear as an open circuit at the junction of D3472 and the receiver path.

## 2.5.6 Harmonic Filter

Components L3491-L3493 and C3491-C3499 form a seven-pole Chebychev low-pass filter to attenuate harmonic energy of the transmitter. R3491 is used to drain electrostatic charge that might otherwise build up on the antenna. The harmonic filter also prevents high level RF signals above the receiver passband from reaching the receiver circuits, improving spurious response rejection.

## 2.5.7 Power Control

The transmitter uses the power control IC (PCIC, U3501) to control the power output of the radio. A portion of the forward and reflected RF power from the transmitter is sampled by the directional coupler, rectified and summed, to provide a dc voltage to the RFIN port of the PCIC (pin 1) which is proportional to the sampled RF power.

The ASFIC contains a digital to analog converter (DAC) which provides a reference voltage of the control loop to the PCIC via R3505. The reference voltage level is programmable through the SPI line of the PCIC. This reference voltage is proportional to the desired power setting of the transmitter, and is factory programmed at several points across the frequency range of the transmitter to offset frequency response variations of the transmitter's power detector circuit.

The PCIC provides a dc output voltage at pin 4 (INT) which is amplified and shifted in dc level by U3402. The 0 to 4 Vdc range at U3501, pin 4 is translated to a 0 to 8.5 Vdc range at the output of U3402, and applied as VCONT to the power-adjust input pin of the first transmitter stage U3401. This adjusts the transmitter power output to the intended value. Variations in forward or reflected transmitter power cause the dc voltage at pin 1 to change, and the PCIC adjusts the control voltage above or below its nominal value to raise or lower output power.

Capacitors C3502-4, in conjunction with resistors and integrators within the PCIC, control the transmitter power-rise (key-up) and power-decay (de-key) characteristic to minimize splatter into adjacent channels.

U3502 is a temperature-sensing device, which monitors the circuit board temperature in the vicinity of the transmitter driver and final devices, and provides a dc voltage to the PCIC (TEMP, pin 29) proportional to temperature. If the dc voltage produced exceeds the set threshold in the PCIC, the transmitter output power is reduced so as to reduce the transmitter temperature.

The power control circuitry includes a safety switch (S3440) that consists of a conductive portion of the rubber pad which pushes the RF final transistor Q3441 against the chassis. When the chassis cover and rubber pad are properly assembled, the conductive portion of the pad contacts a pattern on the circuit board, electrically closing switch S3440. If the cover and pad are not in place, switch S3440 is open-circuited and the power control circuit is disabled. This prevents thermal damage of the RF final transistor which might occur if the transmitter is operated without adequate heatsinking.

## 2.6 Frequency Synthesis

The frequency synthesizer subsystem consists of the reference oscillator (Y3263), the Low Voltage Fractional-N synthesizer (LVFRAC-N, U3201), and the voltage-controlled oscillators and buffer amplifiers (U3301, Q3301, Q3304 and associated circuits).

### 2.6.1 Reference Oscillator

The reference oscillator (Y3263) contains a temperature compensated crystal oscillator with a frequency of 16.8 MHz. An analog-to-digital (A/D) converter internal to U3201 (LVFRAC-N) and controlled by the  $\mu$ P via serial interface (SRL) sets the voltage at the warp output of U3201 (pin 25) to set the frequency of the oscillator. The output of the oscillator (Y3263 pin 3) is applied to pin 23 (XTAL1) of U3201 via R3263 and C3235.

## 2.6.2 Fractional-N Synthesizer

The LVFRAC-N synthesizer IC (U3201) consists of a pre-scaler, a programmable loop divider, control divider logic, a phase detector, a charge pump, an A/D converter for low frequency digital modulation, a balance attenuator to balance the high frequency analog modulation and low frequency digital modulation, a 13 volt positive voltage multiplier, a serial interface for control, and finally a super filter for the regulated 5 volts.

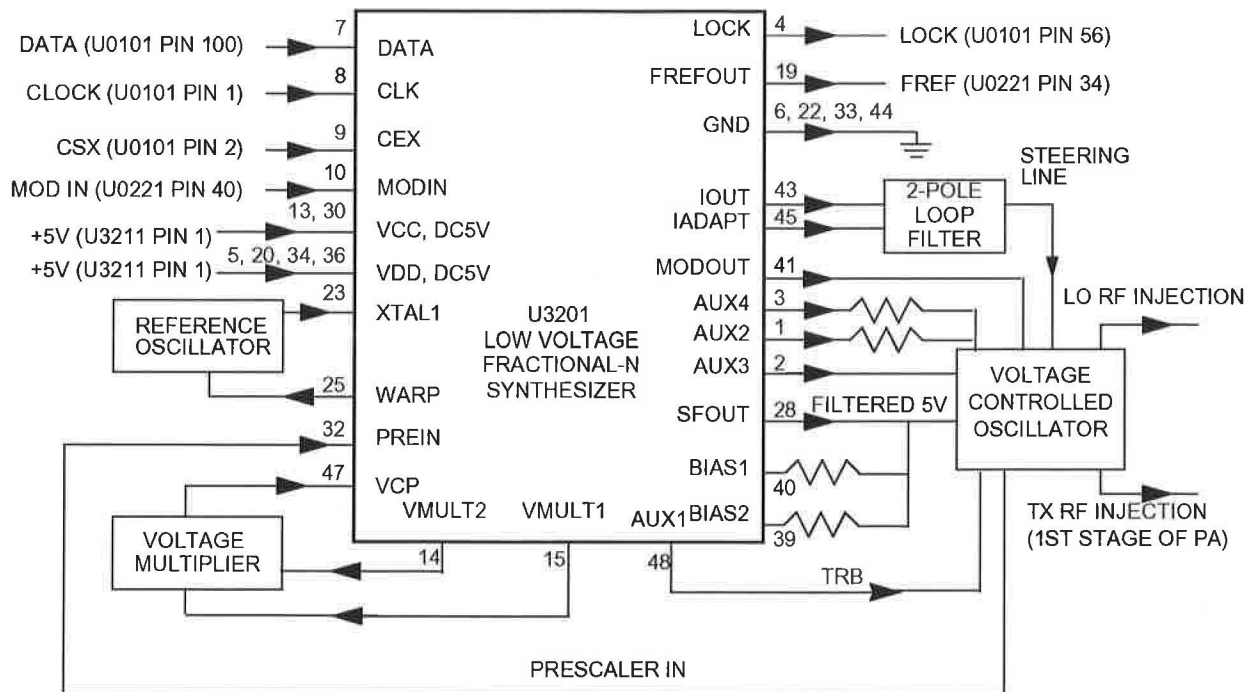

**Figure 2-9. 200 MHz Synthesizer Block Diagram**

A voltage of 5V applied to the super filter input (U3201 pin 30) supplies an output voltage of 4.5 Vdc (VSF) at pin 28. It supplies the VCO, VCO modulation bias circuit (via R3363) and the synthesizer charge pump resistor network (R3251, R3252). The synthesizer supply voltage is provided by the 5V regulator U3211.

In order to generate a high voltage to supply the phase detector (charge pump) output stage at pin VCP (U3201-47), a voltage of 13 Vdc is being generated by the positive voltage multiplier circuits (D3201, C3202, C3203). This voltage multiplier is basically a diode capacitor network driven by two signals (1.05MHz) 180 degrees out of phase signals (U3201-14 and -15).

Output LOCK (U3201-4) provides information about the lock status of the synthesizer loop. A high level at this output indicates a stable loop. IC U3201 provides the 16.8 MHz reference frequency at pin 19.

The serial interface (SRL) is connected to the  $\mu$ P via the data line DATA (U3201-7), clock line CLK (U3201-8), and chip enable line CSX (U3201-9).

### 2.6.3 Voltage Controlled Oscillator (VCO)

The Voltage Controlled Oscillator (VCO) consists of the VCO/Buffer IC (VCOBIC, U3301), the TX and RX tank circuits, the external RX VCO and buffer stages, and the modulation circuits.

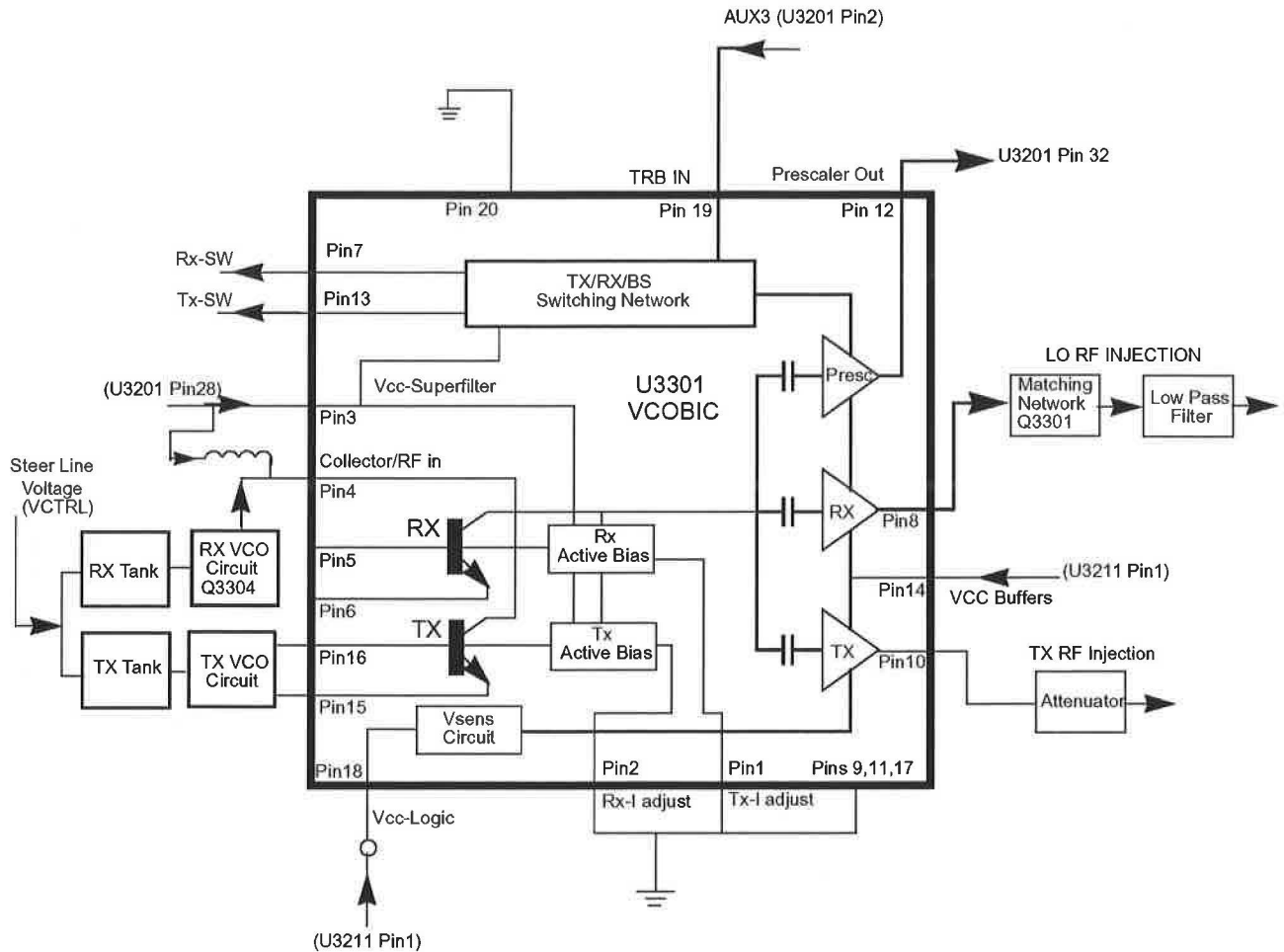

**Figure 2-10.** 200 MHz VCO Block Diagram

The VCOBIC together with the Fractional-N synthesizer (U3201) generates the required frequencies in both the transmit and receive modes. The TRB line (U3301, pin 19) determines which tank circuits and internal buffers are to be enabled. A high level on TRB enables the TX tank and TX output (pin 10), and a low enables the RX tank and RX output (pin 8). A sample of the signal from the enabled RF output is routed from U3301, pin 12 (PRESC\_OUT), via a low pass filter, to U3201, pin 32 (PREIN).

A steering line voltage (VCTRL) between 2.5 volts and 11 volts at varactor diode D3361 tune the full TX frequency range (TXINJ) from 217 MHz to 222 MHz, and varactor diode D3341 tunes the full RX frequency range (RXINJ) from 262 MHz to 267 MHz. The RX tank circuit uses a Hartley configuration for wider bandwidth. For the RX tank circuit, an external transistor Q3304 is used for better side-band noise.

The operating point of external RX VCO buffer Q3301 is stabilized by current mirror Q3302 which adjusts Q3301's base current to maintain its collector current constant. Q3301-2 are enabled by a high at U3301 pin 7, via transistor switches Q3310-11. In the TX mode, the modulation signal (VCOMOD) from the LVFRAC-N synthesizer IC (U3201 pin 41) is applied to varactor diode D3362, which modulates the TX VCO frequency via capacitor C3362. Varactor D3362 is biased for linearity from the VSF via R3363.

## 2.6.4 Synthesizer Operation

The complete synthesizer subsystem consists of the low voltage FRAC-N (LVFRACN), reference oscillator (a crystal oscillator with temperature compensation), charge pump circuit, loop filter circuit and a dc supply. The output signal PRESC from the VCOBIC (U3301 pin 12) is fed to U3201 pin 32 (PREIN) via a low pass filter (C3318, L3318 and C3226) which attenuates harmonics and provides the correct level to close the synthesizer loop.

The pre-scaler in the synthesizer (U3201) is a dual modulus type with selectable divider ratios. The divider ratio of the pre-scaler is controlled by the loop divider, which in turn receives its inputs via the SRL. The output of the pre-scaler is applied to the loop divider. The output of the loop divider is connected to the phase detector, which compares the loop divider's output signal with the reference signal. The reference signal is generated by dividing down the signal of reference oscillator Y3263.

The output signal of the phase detector is a pulsed dc signal which is routed to the charge pump. The charge pump outputs a current at U3201 pin 43 (IOUT). The loop filter (which consists of R3221-R3223, R3343, C3221-C3224, and C3346) transforms this current into a voltage that is applied to the varactor diodes (D3361 for transmit, D3341 for receive) to alter the output frequency of the appropriate VCO. The current can be set to a value fixed within the LVFRAC-N IC, or to a value determined by the currents flowing into BIAS 1 (U3201-40) or BIAS 2 (U3201-39). The currents are set by the value of R3251 and R3252 respectively. The selection of the three different bias sources is done by software programming.

To reduce synthesizer lock time when new frequency data has been loaded into the synthesizer, the magnitude of the loop current is increased by enabling the IADAPT pin (U3201-45) for a certain software programmable time (adapt mode). The adapt mode timer is started by a low to high transient of the CSX line. When the synthesizer is within the lock range, the current is determined only by the resistors connected to BIAS 1 and BIAS 2, or by the internal current source. A settled synthesizer loop is indicated by a high level signal at U3201-4 (LOCK).

The LOCK signal is routed to one of the  $\mu$ P's ADC inputs (U0101-56). From the measured voltage, the  $\mu$ P determines whether LOCK is active.

To modulate the PLL, the two spot modulation method is utilized. Via U3201, pin 10 (MODIN), the audio signal is applied to both the A/D converter (low frequency path) as well as the balance attenuator (high frequency path). The A/D converter changes the low frequency analog modulating signal into a digital code that is applied to the loop divider, thereby causing the carrier to deviate. The balance attenuator is used to adjust the VCO's deviation sensitivity to high frequency modulating signals. The output of the balance attenuator is present at the MODOUT port (U3201-41) and connected to the VCO modulation diode D3362 via R3364.

## 2.7 700 MHz Receiver Front-End

The 700 MHz receiver design is separated into two blocks, the front end and the back end. The overall block diagram of the receiver is shown in Figure 2-11. Detailed descriptions of these stages are contained in the paragraphs that follow.

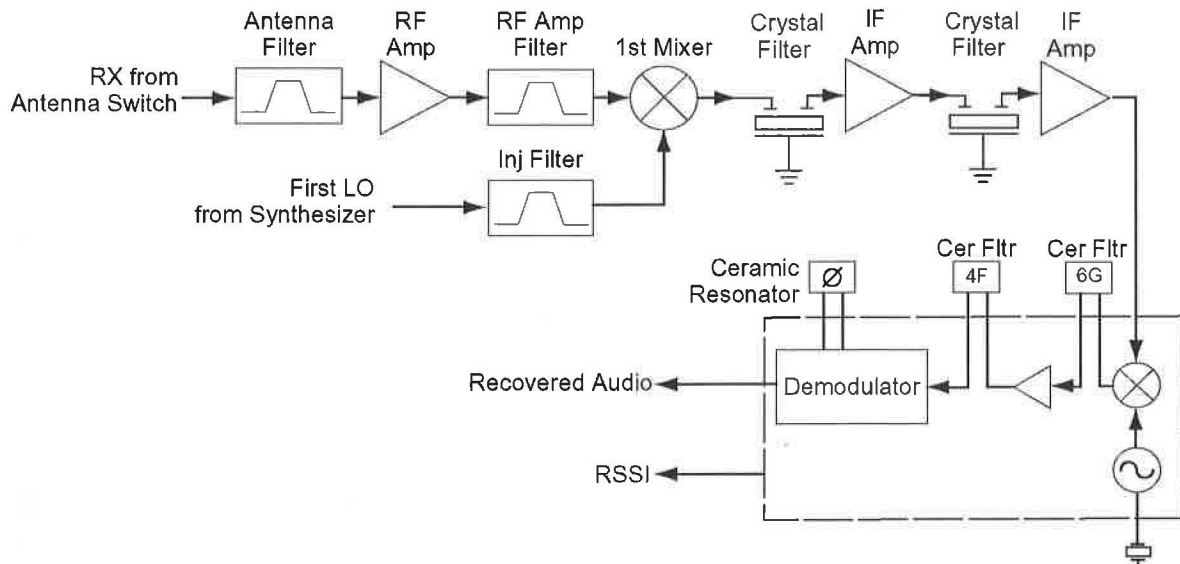

Figure 2-11. 700 MHz Receiver Block Diagram

### 2.7.1 Receiver Front-End

The received signal from the antenna is routed through the harmonic filter and antenna switch and applied to the antenna filter FL3000. This is a fixed-tuned 3-pole ceramic bandpass filter with a passband of 744 MHz to 766 MHz and an insertion loss of 2.6 dB. The output of this filter is coupled to RF amplifier Q3001. Diode CR3000 protects the RF amplifier by limiting excessive RF levels.

The output of the RF amplifier is applied to the RF amp filter FL3001, identical to FL3000. The output of FL3001 is routed through a switchable local-distance attenuator consisting of R3013, D3000, Q3003 and associated components. Normally Q3003 and D3000 are on and the receiver sensitivity is at maximum. When Q3003 and D3000 are off, the series resistor R3013 reduces receiver sensitivity to minimize intermodulation when operating in the presence strong undesired signals. The output of the local-distance attenuator is connected to the passive double-balanced mixer consisting of components T3001, T3002, and CR3001. High-side injection from the frequency synthesizer is band-pass filtered by C3021-C3029 and L3008-9 to remove second harmonic energy which may degrade half-IF spurious rejection performance, and applied to T3002 at a level of +18 dBm.

The IF output from T3002 is applied to a diplexer (L3006-7, C3017-3020 and R3014) which matches the 73.35 MHz IF signal to the crystal filter and terminates the mixer into 50Ω at all other frequencies.

### 2.7.2 Receiver Back-End

The receiver back end is a dual conversion design. The 73.35 MHz high IF consists of 2-pole crystal filter FL3101, IF amp Q3101, 2-pole crystal filter FL3102 and IF amp Q3102. Each crystal filter has a 3 dB bandwidth of 9.0 kHz and a maximum insertion loss of 2 dB. The output of Q3102 is applied to the input of the receiver IFIC U3101. Diode D3101 prevents overdriving the IFIC.

The IFIC is a low-voltage monolithic FM IF system incorporating a mixer/oscillator, two limiting IF amplifiers, quadrature detector, logarithmic received signal strength indicator (RSSI), voltage regulator and audio and RSSI op amps. The second LO frequency is determined by Y3101. Additional IF selectivity is provided by two ceramic filters, FL3111 (between the second mixer and IF amp) and FL3113 (between the IF amp and the limiter input). FL3111 is a 6 element filter with a BW6 = 9 kHz. FL3113 is a 4 element filter with a BW6 = 12 kHz. These bandwidths are optimum for 12.5 kHz channel spacing systems. Ceramic resonator Y3102 provides phase vs. frequency characteristic required by the quadrature detector, with 90 degree phase shift occurring at 455 kHz. Buffer Q3141 provides a lower driving impedance from the limiter to the resonator, improving the IF waveform and lowering distortion.

## 2.8 Transmitter Power Amplifier (PA) 15 W

The radio's 15W power amplifier (PA) is a three stage amplifier used to amplify the output from the VCOBIC to the radio transmit level. It consists of the following three stages in the line-up. The first stage is a LDMOS predriver (U3401) that is controlled by pin 4 of PCIC (U3501) via U3503 (CNTLVLTG). It is followed by another LDMOS stage (Q3420) and an LDMOS final stage (Q3440).

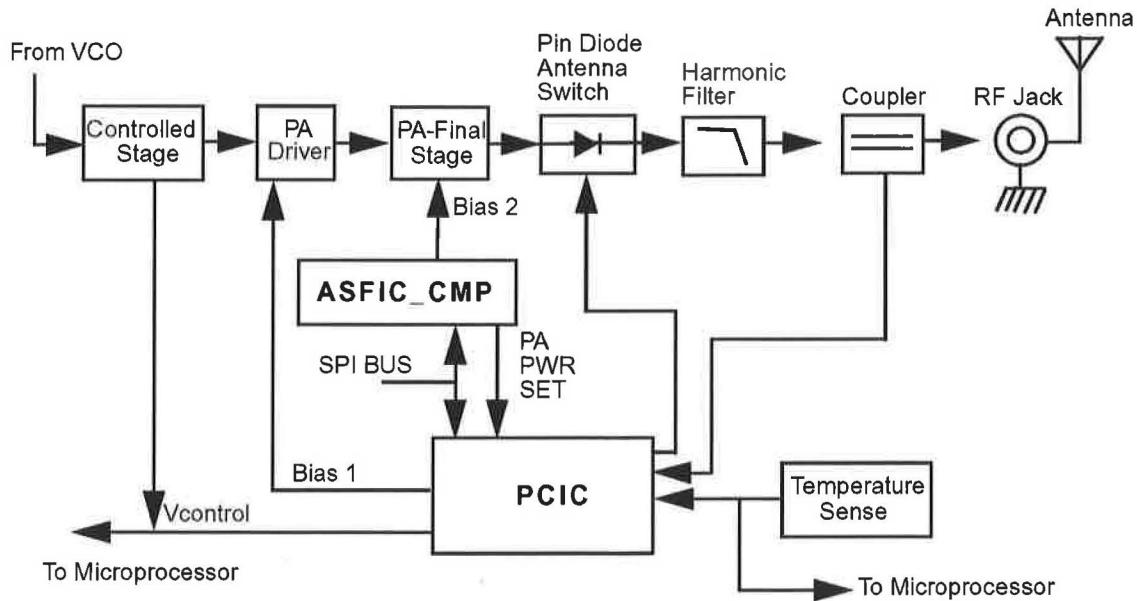

Figure 2-12. 700 MHz Transmitter Block Diagram

### 2.8.1 Power Controlled Stage

The first stage (U3401) is an integrated circuit containing two LDMOS FET amplifier stages having a combined gain of 11 dB. It amplifies the RF signal from the VCO (TXINJ). The output power of stage U3401 is controlled by a DC voltage applied to pin 1 from opamp U3503-1 pin 1. The control voltage simultaneously varies the bias of two FET stages within U3401. This biasing point determines the overall gain of U3401 and therefore its output drive level to Q3420, which in turn controls the output power of the PA.

Opamp U3503-1 monitors the drain current of U3401 via resistor R3513 and adjusts the bias voltage of U3401 so that the current remains constant. The PCIC (U3501) provides a DC output voltage at pin 4 (INT) which sets the reference voltage of the current control loop. An increasing power output causes the DC voltage from the PCIC to fall, and U3503-1 adjusts the bias voltage for a lower drain current to reduce the gain of the stage.



In the receive mode the DC voltage control line is at ground level which switches off the biasing voltage to U3401 via U3503.

## 2.8.2 Driver Stage

The next stage is an 11 dB gain LDMOS device (Q3420) which requires a positive gate bias and a quiescent current flow for proper operation. The voltage of the line PCIC\_MOSBIAS\_1 is set in transmit mode by PCIC pin 24 and fed to the gate of Q3420 via the resistive network R3525-6. The bias voltage is tuned in the factory.

## 2.8.3 Final Stage

The final stage is an enhancement-mode N-Channel LDMOS device (Q3440) providing a gain of 17 dB. This device also requires a positive gate bias and a quiescent current flow for proper operation. The voltage of the line Bias\_2\_700\_PA\_1 is set in transmit mode by the ASFIC and fed to the gate of Q3440 via the resistive network R3527-8. This bias voltage is also tuned in the factory. If the transistor is replaced, the bias voltage must be tuned using the Customer Programming Software (CPS). Care must be taken not to damage the device by exceeding the maximum allowed bias voltage. The device's drain current is drawn directly from the radio's dc supply voltage input, A+, via L3442. A matching network consisting of C3448-C3452 and L3442 transforms the impedance to 50Ω and feeds the antenna switch and harmonic filter.

## 2.8.4 Antenna Switch

The antenna switch utilizes the existing dc feed (A+) to the last stage device (Q3440). Both PIN diodes D3470 and D3471 are turned on during key-up by forward biasing them. Forward biasing is achieved pulling down the voltage at the cathode end of D3471 to around 11.8V (0.7V drop across each diode). Q3471 is configured as a current source that maintains the current through the antenna switch diodes at 90 mA, as set by VR3470 and R3472. The current source is enabled only during transmit by Q3470 and U3501 pin 32.

## 2.8.5 Harmonic Filter

Inductors L3474-6, capacitors C3481-2 and two microstrip stubs form a low-pass filter to attenuate harmonic energy from the transmitter. R3475 is used to drain any electrostatic charges that might otherwise build up on the antenna. The harmonic filter also prevents high level RF signals above the receiver passband from reaching the receiver circuits, improving spurious response rejection. L3479 and C3492-3 form a trap that improves 2nd harmonic rejection.

## 2.8.6 Bi-Directional Coupler

The Bi-directional coupler is a microstrip printed circuit which couples a small amount of the forward and reverse power of the RF power from Q3440. The coupled signal is rectified to an output power proportional dc voltage by the diodes D3472 and D3473 and sent to the RFIN of the PCIC. The PCIC controls the gain of stage U3401 as necessary to hold this voltage constant. This ensures the forward power out of the radio is held to a constant value.

## 2.8.7 Power Control

The transmitter uses the Power Control IC (PCIC, U3501) to control the power output of the radio. A portion of the forward RF power from the transmitter is sampled by the bi-directional coupler and rectified, to provide a dc voltage to the RFIN port of the PCIC (pin 1) which is proportional to the sampled RF power.

The PCIC has internal digital to analog converters (DACs) which provide the reference voltage of the control loop. The reference voltage level is programmable through the SPI line of the PCIC. This reference voltage is proportional to the desired power setting of the transmitter, and is factory

programmed at several points across the frequency range of the transmitter to offset frequency response variations of the transmitter's power detector circuits.

The PCIC provides a dc output voltage at pin 4 (INT) which sets the drain current of the first stage (U3401) via current control opamp U3503-1. This adjusts the transmitter power output to the intended value. Variations in forward transmitter power cause the dc voltage at pin 1 to change, and the PCIC adjusts the control voltage above or below its nominal value to raise or lower output power.

Capacitors C3501-3, in conjunction with resistors and integrators within the PCIC, control the transmitter power-rise (key-up) and power-decay (de-key) characteristic to minimize splatter into adjacent channels.

U3502 is a temperature-sensing device, which monitors the circuit board temperature in the vicinity of the transmitter driver and final devices, and provides a dc voltage to the PCIC (TEMP, pin 29) proportional to temperature. If the dc voltage produced exceeds the set threshold in the PCIC, the transmitter output power is reduced so as to reduce the transmitter temperature.

The power control circuitry includes a safety switch (S3501) that consists of a conductive portion of the rubber pad which pushes the RF final transistor Q3440 against the chassis. When the chassis cover and rubber pad are properly assembled, the conductive portion of the pad contacts a pattern on the circuit board, electrically closing switch S3501. If the cover and pad are not in place, switch S3501 is open-circuited and the power control circuit is disabled. This prevents thermal damage of the RF final transistor which might occur if the transmitter is operated without adequate heatsinking.

## 2.9 Frequency Synthesis

The synthesizer subsystem consists of the reference oscillator, the low voltage fractional-N synthesizer (LVFRAC-N), and the Voltage Controlled Oscillator VCO.

### 2.9.1 Reference Oscillator

The reference oscillator (Y3201) contains a temperature compensated crystal oscillator with a frequency of 16.8 MHz. An Analog-to-Digital (A/D) converter internal to U3201 (LVFRAC-N) and controlled by the  $\mu$ P via serial interface (SRL) sets the voltage at the warp output of U3201, pin 25 to set the frequency of the oscillator. The output of the oscillator (pin 3 of Y3201) is applied to pin 23 (XTAL1) of U3201 via an RC series combination.

### 2.9.2 Fractional-N Synthesizer

The LVFRAC-N synthesizer IC (U3201) consists of a pre-scaler, a programmable loop divider, control divider logic, a phase detector, a charge pump, an A/D converter for low frequency digital modulation, a balanced attenuator to balance the high frequency analog modulation and low frequency digital modulation, a 13V positive voltage multiplier, a serial interface for control, and finally a super filter for the regulated 5 volts.

A voltage of 5V applied to the super filter input (U3201 pin 30) supplies an output voltage of 4.5 Vdc (VSF) at pin 28. It supplies the VCO and the synthesizer charge pump resistor network. The synthesizer supply voltage is provided by the 5V regulator U3202.

In order to generate a high voltage to supply the phase detector (charge pump) output stage at pin VCP (U3201 pin 47), a voltage of 13 Vdc is being generated by the positive voltage multiplier circuitry (D3201 and C3212-13). This voltage multiplier is basically a diode capacitor network driven by two signals (1.05MHz) 180 degrees out of phase (U3201-14 and -15).

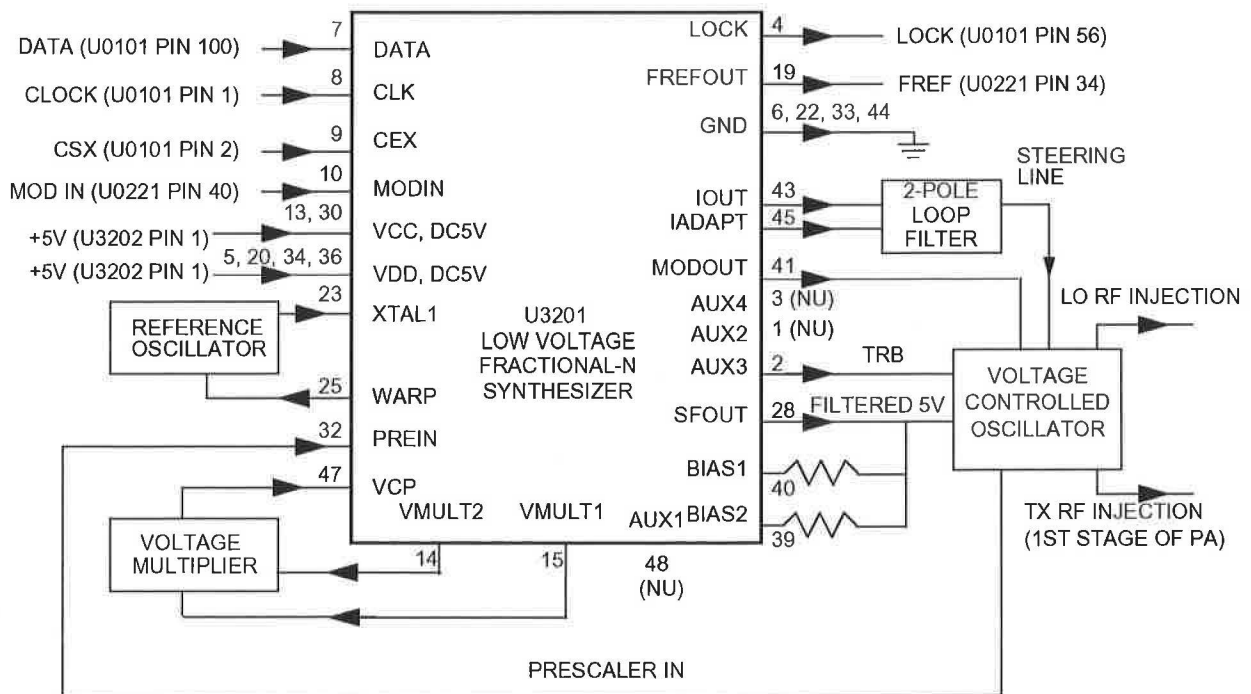

**Figure 2-13.** 700 MHz Synthesizer Block Diagram

Output LOCK (U3201-4) provides information about the lock status of the synthesizer loop. A high level at this output indicates a stable loop. IC U3201 provides the 16.8 MHz reference frequency at pin 19.

The serial interface (SRL) is connected to the  $\mu$ P via the data line DATA (U3201-7), clock line CLK (U3201-8), and chip enable line CSX (U3201-9).

### 2.9.3 Voltage Controlled Oscillator (VCO)

The Voltage Controlled Oscillator (VCO) consists of the VCO buffer IC (VCOBIC, U3301), the TX and RX tank circuits, the external RX buffer stages, and the modulation circuits.

The VCOBIC together with Fractional-N synthesizer (U3201) generates the required frequencies in both transmit and receive modes. The TRB line (U3301 pin 19) determines which tank circuits and internal buffers are to be enabled. A high level on TRB enables TX tank and TX output (pin 10), and a low enables RX tank and RX output (pin 8). A sample of the signal from the enabled output is routed from U3301 pin 12 (PRESC\_OUT), via a low pass filter, to pin 32 of U3201 (PREIN).

A steering line voltage (VCTRL) between 3.0V and 10.0V at varactor diode CR3303 will tune the full TX frequency range (TXINJ) from 746 MHz to 794 MHz, and at varactor diodes CR3301 and CR3302 will tune the full RX frequency range (RXINJ) from 819 MHz to 837 MHz. The tank circuits uses the Hartley configuration for wider bandwidth. External VCO transistors (Q3305, TX and Q3306, RX) are used for lower noise.

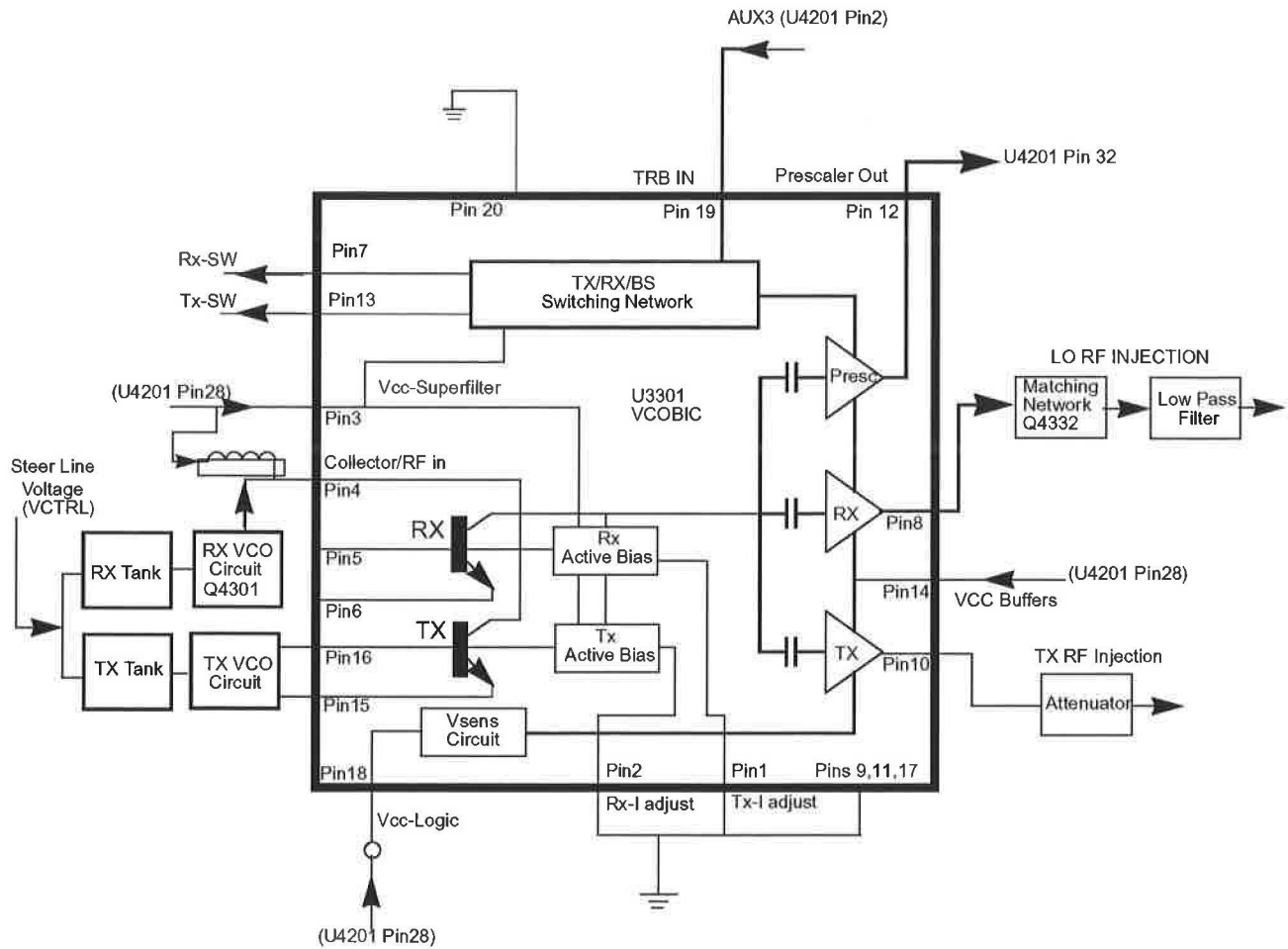

**Figure 2-14. 700 MHz VCO Block Diagram**

The external RX buffers (Q3301-2) are enabled by a high at U3301 pin 7 via transistor switch Q3303. In TX mode the modulation signal (VCOMOD) from the LVFRAC-N synthesizer IC (U3201 pin 41) is superimposed on the steering line voltage (VCTRL) via an attenuator network (R3319-20, C3241 and C3245).

## 2.9.4 Synthesizer Operation

The complete synthesizer subsystem comprises mainly of a low voltage FRAC-N (LVFRACN) IC, Reference Oscillator (crystal oscillator with temperature compensation), charge pump circuits, loop filter circuits, and dc supply. The output signal (PRESC\_OUT) of the VCOBIC (U3301, pin12) is fed to of U3201, pin 32 (PREIN) via a low pass filter (L3205 and C3246) which attenuates harmonics and provides correct level to close the synthesizer loop.

The pre-scaler in the synthesizer (U3201) is basically a dual modulus pre-scaler with selectable divider ratios. The divider ratio of the pre-scaler is controlled by the loop divider, which in turn receives its inputs via the SRL. The output of the pre-scaler is applied to the loop divider. The output of the loop divider is connected to the phase detector, which compares the loop divider's output signal with the reference signal. The reference signal is generated by dividing down the signal of the reference oscillator (Y3201).

The output signal of the phase detector is a pulsed dc signal which is routed to the charge pump. The charge pump outputs a current at pin 43 of U3201 (IOUT). The loop filter (which consists of R3214-15, R3218, C3235-7, C3245 and L3204) transforms this current into a voltage that is applied to the varactor diodes CR3303 for transmit, CR3301-2 for receive and alters the output frequency of the VCO. The current can be set to a value fixed in the LVFRAC-N IC or to a value determined by the currents flowing into BIAS 1 (U3201-40) or BIAS 2 (U3201-39). The currents are set by the value of R3211 or R3213 respectively. The selection of the three different bias sources is done by software programming.

LOCK (U3201-4) signal is routed to one of the  $\mu$ P's ADCs input U101-56. From the voltage the  $\mu$ P determines whether LOCK is active.

In order to modulate the PLL the two spot modulation method is utilized Via pin 10 (MODIN) on U3201. The audio signal is applied to both the A/D converter (low frequency path) as well as the balanced attenuator (high frequency path). The A/D converter converts the low frequency analog modulating signal into a digital code which is applied to the loop divider, thereby causing the carrier to deviate. The balance attenuator is used to adjust the VCO's deviation sensitivity to high frequency modulating signals. The output of the balance attenuator is present at the MODOUT port (U3201-41) and connected to the steering line via R3219-20 and C3241.

## 2.10 Control Head (CDM1550•LS<sup>+</sup>)

The control head contains the internal speaker, the on/off/volume knob, the microphone connector, several buttons to operate the radio, several indicator light emitting diodes (LEDs) to inform the user about the radio status, and a 14 character liquid crystal display (LCD) for alpha - numerical information, e.g. channel number or call address name. To control the LED's and the LCD, and to communicate with the host radio the control head uses the Motorola 68HC11E9  $\mu$ P.

### 2.10.1 Power Supplies

The power supply to the control head is taken from the host radio's FLT A+ voltage via connector J0801 pin 3 and the regulated +5V via connector J0801 pin 7. The voltage FLT A+ is at battery level and is used for the LED's, the back light and to power up the radio via on / off / volume knob. The stabilized +5 volt is used for the  $\mu$ P, display, display driver, and keypad buttons. The voltage USW 5V derived from the FLT A+ voltage and stabilized by the series combination of R0822, VR0822 is used to buffer the internal RAM of the  $\mu$ P (U0831). C0822 allows the battery voltage to be disconnected for a couple of seconds without losing RAM parameters. Dual diode D0822 prevents radio circuits from discharging this capacitor. When the supply voltage is applied to the radio, C0822 is charged via R0822 and D0822. To avoid that the  $\mu$ P enters the wrong mode when the radio is switched on while the voltage across C0822 is still too low, the regulated 5V charge C0822 via diode D0822.

### 2.10.2 Power On / Off

The on/off/volume knob when pressed switches the radio's voltage regulators on by connecting line ON OFF CONTROL to line UNSW 5V via D0821. Additionally, 5 volts at the base of digital transistor Q0822 informs the control head's  $\mu$ P about the pressed knob. The  $\mu$ P asserts pin 62 and line CH REQUEST low to hold line ON OFF CONTROL at 5 volts via Q0823 and D0821. The high line ON OFF CONTROL also informs the host radio, that the control head's  $\mu$ P wants to send data via SBEP bus. When the radio returns a data request message, the  $\mu$ P informs the radio about the pressed knob. If the radio was switched off, the radio's  $\mu$ p switches it on and vice versa. If the on/off/volume knob is pressed while the radio is on, the software detects a low state on line ON OFF SENSE, the radio is alerted via line ON OFF CONTROL and sends a data request message. The control head  $\mu$ p will inform the radio about the pressed knob and the radio's  $\mu$ p switches the radio off.

### 2.10.3 Microprocessor Circuit

The control head uses the Motorola 68HC11E9 microprocessor ( $\mu$ p) (U0831) to control the LED's and the LCD and to communicate with the host radio. RAM and ROM are contained within the  $\mu$ P itself.

The  $\mu$ P generates its clock using the oscillator inside the  $\mu$ P along with a 8 MHz ceramic resonator (U0833) and R0920.

The  $\mu$ P's RAM is always powered to maintain parameters such as the last operating mode. This is achieved by maintaining 5 volts at  $\mu$ p, pin 25. Under normal conditions, when the radio is off, USW 5V is formed by FLT A+ running to D0822. C0822 allows the battery voltage to be disconnected for a couple of seconds without losing RAM parameters. Diode D0822 prevents radio circuits from discharging this capacitor.

There are eight analog-to-digital converter ports (A/D) on the  $\mu$ p. They are labeled within the device block as PE0-PE7. These lines sense the voltage level ranging from 0 to 5V of the input line and convert that level to a number ranging from 0 to 255 which can be read by the software to take appropriate action.

Pin VRH is the high reference voltage for the A/D ports on the  $\mu$ p. If this voltage is lower than +5V the A/D reading is incorrect. Likewise pin VRL is the low reference for the A/D ports. This line is normally tied to ground. If this line is not connected to ground, the A/D readings could be incorrect.

The  $\mu$ P determines the used keypad type and the control head ID by reading the levels at ports PC0 – PC7. Connections JU0852/3/4 are provided by the individual keypads.

The MODB / MODA input of the  $\mu$ P must be at a logic 1 for it to start executing correctly. The XIRQ and the IRQ pins should also be at a logic 1.

Voltage sense device U0832 provides a reset output that goes to 0 volts if the regulated 5 volts goes below 4.5 volts. This is used to reset the controller to prevent improper operation.

### 2.10.4 SBEP Serial Interface

The host radio (master) communicates to the control head  $\mu$ P (slave) through its SBEP bus. This bus uses only line BUS+ for data transfer. The line is bi-directional, meaning that either the radio or the control head  $\mu$ P can drive the line. The  $\mu$ P sends serial data via pin 50 and D0831 and it reads serial data via pin 47. Whenever the  $\mu$ P detects activity on the BUS+ line, it starts communication.

When the host radio needs to communicate to the control head  $\mu$ P, it sends data via line BUS+. Any transition on this line generates an interrupt and the  $\mu$ P starts communication. The host radio may send data like display information, LED and back light status or it may request the control head ID or the keypad ID.

When the control head  $\mu\text{P}$  wants to communicate to the host radio, the  $\mu\text{P}$  brings request line CH REQUEST to a logic 0 via  $\mu\text{P}$ , pin 62. This switches on Q0823, which pulls line ON OFF CONTROL high through diode D0821. A low to high transition on this line informs the radio, that the control head requires service. The host radio then sends a data request message via BUS+ and the control head  $\mu\text{P}$  replies with the data it wanted to send. This data can be information such as a key is pressed or the volume knob rotated.

The control head  $\mu\text{P}$  monitors all messages sent via BUS+, but ignores any data communication between host radio and CPS or Universal Tuner.

### 2.10.5 Keypad Keys

The control head keypad is a 6-key keypad (Model B) or a 10- key keypad (model C). All keys are configured as two analog lines read by  $\mu\text{P}$ , pins 13 and 15. The voltage on the analog lines varies between 0 volts and +5 volts depending on which key has been pressed. If no key is pressed, the voltage at both lines is 5 volts. The key configuration can be thought of as a matrix, where the two lines represent one row and one column. Each line is connected to a resistive divider powered by +5 volts. If a button is pressed, it will connect one specific resistor of each divider line to ground level and thereby reduce the voltages on the analog lines. The voltages of the lines are A/D converted inside the  $\mu\text{P}$  (ports PE 0 - 1) and specify the pressed button. To determine which key is pressed, the voltage of both lines must be considered.

An additional pair of analog lines and A/D  $\mu\text{P}$  ports (PE 3 - 2) is available to support a keypad microphone, connected to the microphone connector J0811. Any microphone key press is processed the same way as a key press on the control head.

### 2.10.6 Status LED and Back Light Circuit

All the indicator LED's (red, yellow, green) are driven by current sources. To change the LED status the host radio sends a data message via SBEP bus to the control head  $\mu\text{P}$ . The control head  $\mu\text{P}$  determines the LED status from the received message and switches the LED's on or off via port PB 7 - 0 and port PA4. The LED status is stored in the  $\mu\text{P}$ 's memory. The LED current is determined by the resistor at the emitter of the respective current source transistor.

The back light for the LCD and the keypad is controlled by the host radio the same way as the indicator LED's using  $\mu\text{P}$  port PA 5. This port is a Pulse Width Modulator (PWM) output. The output signal charges capacitor C0843 through R0847. By changing the pulse width under software control, the dc voltage of C0843 and thereby, the brightness of the back light can be changed in four steps. The keypad back light current is drawn from the FLT A+ source and controlled by transistor Q0933. The current flowing through the LED's cause a proportional voltage drop across the parallel resistors R0947, R0948. This voltage drop is amplified by the op-amp U0931-2. U0931-2 and Q0934 form a differential amplifier. The voltage difference between the base of Q0934 and the output of U0931-2 determines the current from the base of the LED control transistor Q0933 and in turn the brightness of the LED's. The  $\mu\text{P}$  controls the LED's by changing the dc level at the base of Q0934. If the base of Q0934 is at ground level, Q0934 is switched off and no current flows through Q0933 and the LED's. If the base voltage of Q0934 rises a current flows through Q0934 and in turn through Q0933 causing the LED's to turn on and a rising voltage drop across R0947, R0948. The rising voltage causes the output of the op-amp to rise and to reduce the base to emitter voltage of Q0934. This decreases the current of Q0933 until the loop has settled.

### 2.10.7 Liquid Crystal Display (LCD)

The LCD H0971 uses the display driver U0971. The display is a single-layer super-twist pneumatic (STN) LCD display. It has 14 characters with a 5\*8 dot matrix for displaying alpha - numerical information and a line with 21 pre - defined icons above the dot matrix.

The driver contains a data interface to the  $\mu\text{P}$ , an LCD segment driver, an LCD power circuit, an oscillator, data RAM and control logic. At power up the driver's control logic is reset by a logic 0 at input SR2 (U0971-15). The driver's internal oscillator is set to about 20 kHz and can be measured at pin 22. The driver's  $\mu\text{P}$  interface is configured to accept 8 bit parallel data input (U0971-D0-D7) from the control head  $\mu\text{P}$  (U0831 port PC0-PC7).

To write data to the driver's RAM the  $\mu\text{P}$  sets chip select (U0971-20) to logic 0 via U0831-11, RD (U0971-18) to logic 1 via (U0831-10) and WR (U0971-17) to logic 0 via U0831-9. With input A0 (U0971-21) set to logic 0 via U0831-12 the  $\mu\text{P}$  writes control data to the driver. Control data includes the RAM start address for the following display data. With input A0 set to logic 1 the  $\mu\text{P}$  then writes the display data to the display RAM. When data transfer is complete the  $\mu\text{P}$  terminates the chip select, RD, and WD activities.

The display driver's power circuit provides the voltage supply for the display. This circuit consists of a voltage multiplier, voltage regulator and a voltage follower. The external capacitors C0971 - C0973 configure the multiplier to double the supply voltage. In this configuration the multiplier output VOUT (U0971-8) supplies a voltage of -5V ( $2 \times -5\text{V}$  below VDD). The multiplied voltage VOUT is sent to the internal voltage regulator. To set the voltage level of the regulator output V5 (U0971-5) this voltage is divided by the resistors R0973 and R0974 and fed back to the reference input VR (U0971-6). In addition the regulator output voltage V5 can be controlled electronically by a control command sent to the driver. With the used configuration the voltage V5 is about -2V. The voltage V5 is resistively divided by the driver's voltage follower to provide the voltages V1 - V4. These voltages are needed for driving the liquid crystals. The level of V5 can be measured by one of the  $\mu\text{P}$ 's analog-to-digital converters (U0831-20) via resistive divider R0975, R0976. To stabilize the display brightness over a large temperature range the  $\mu\text{P}$  measures the temperature via analog-to-digital converter (U0831-18) using temperature sensor U0834. Dependent on the measured temperature the  $\mu\text{P}$  adjusts the driver output voltage V5, and in turn the display brightness, via parallel interface.

## 2.10.8 Microphone Connector Signals

Signals BUS+, PTT IRDEC, HOOK, MIC, HANDSET AUDIO, FLT A+, +5V and 2 A/D converter inputs are available at the microphone connector J0811. Signal BUS+ (J0811-7) connects to the SBEP bus for communication with the CPS or the Universal Tuner. Line MIC (J0811-5) feeds the audio from the microphone to the radio's controller via connector J0801-4. Line HANDSET AUDIO (J0811-8) feeds the receiver audio from the controller (J0801-6) to a connected handset. FLT A+, which is at supply voltage level, and +5V are used to supply any connected accessory like a microphone or a handset.

The two A/D converter inputs (J0811-9/10) are used as a microphone with keypad. A pressed key changes the dc voltage on both lines. The voltages depend on which key is pressed. The  $\mu\text{P}$  determines, from the voltage on these lines, which key is pressed and sends this information to the host radio.

Line PTT IRDEC (J0811-6) is used to key up the radio's transmitter. While the PTT button on a connected microphone is released, line PTT IRDEC line is pulled to a +5 volts level by R0843. Transistor Q0843 is then switched on causing a low at  $\mu\text{P}$  port PA2. When the PTT button is pressed, signal PTT IRDEC is pulled to ground level. This switches off Q0843 and the resulting high level at  $\mu\text{P}$  port PA2 informs the  $\mu\text{P}$  about the pressed PTT button. The  $\mu\text{P}$  informs the host radio about any status change on the PTT IRDEC line via the SBEP bus.

When line PTT IRDEC is connected to FLT A+ level, transistor Q0821 is switched on through diode VR0821 pulling the level on the line ON OFF CONTROL to FLT A+ level. This switches on the radio and puts the radio's  $\mu\text{P}$  in bootstrap mode. Bootstrap mode is used to load the firmware into the radio's flash memory.

The HOOK input (J0811-3) is used to inform the  $\mu\text{P}$  when the microphone's hang-up switch is engaged. Dependent on the CPS programming the  $\mu\text{P}$  may take actions like turning the audio PA on or off. While the hang up switch is open, line HOOK is pulled to +5 volts level by R0841. Transistor



Q0841 is switched on causing a low at  $\mu$ P port PA1. When the HOOK switch is closed, signal HOOK is pulled to ground level. This switches off R0841 and the resulting high level at  $\mu$ P port PA1 informs the  $\mu$ P about the closed hang up switch. The  $\mu$ P informs the host radio about any status change on the HOOK line via SBEP bus.

### **2.10.9 Speaker**

The control head contains a speaker for the receiver audio. The receiver audio signal from the differential audio output of the audio amplifier located on the radio's controller is fed via connector J0801-10, -11 to the speaker connector P0801, pins 1 and 2. The speaker is connected to the speaker connector P0801. The control head speaker can only be disconnected if an external speaker, connected on the accessory connector, is used.

### **2.10.10 Electrostatic Transient Protection**

Electrostatic transient protection is provided for sensitive components in the control head by diodes VR0811 VR0812 and VR0816 - VR0817. The diodes limit any transient voltages. The associated capacitors provide radio frequency interference (RFI) protection.

## **2.11 PassPort Trunking Controller Board (PTCB)**

PassPort is an enhanced trunking protocol developed by Trident Microsystems that supports wide area dispatch networking. A network is formed by linking several trunked sites together to form a single system. This offers users an extended communication coverage area. Additionally, users with PassPort can seamlessly roam among all sites within the network. Seamless roaming means that the radio user does not have to manually change the position on the radio when roaming from site-to-site. For models which feature PassPort Trunking operation, the PassPort Trunking Controller Board is added to the top cover of the radio. This board also provides advanced voice storage features. Refer to Figures 2-2, 2-3, and 2-5 for connector and signal routing from and to the radio and PTCB. The PTCB is a non-servicable board and should be replaced if defective. The schematic and circuit board details are included in this manual for informational purposes only.

This page intentionally left blank

## Chapter 3

# Maintenance

### 3.1 Introduction

This chapter of the manual describes:

- Preventive maintenance
- Safe handling of CMOS and LDMOS devices
- Repair procedures and techniques

### 3.2 Preventive Maintenance

The radios do not require a scheduled preventive maintenance program, however, periodic visual inspection and cleaning is recommended.

#### 3.2.1 Inspection

Check that the external surfaces of the radio are clean, and that all external controls and switches are functional. It is not recommended to inspect the interior electronic circuitry.

#### 3.2.2 Cleaning

The following procedures describe the recommended cleaning agents and the methods to be used when cleaning the external and internal surfaces of the radio. External surfaces include the front cover, housing assembly, and battery case. These surfaces should be cleaned whenever a periodic visual inspection reveals the presence of smudges, grease, and/or grime.

**Note:** Internal surfaces should be cleaned only when the radio is disassembled for servicing or repair.

The only recommended agent for cleaning the external radio surfaces is a 0.5% solution of a mild dishwashing detergent in water. The only factory recommended liquid for cleaning the printed circuit boards and their components is isopropyl alcohol (70% by volume).



WARNING

**CAUTION: The effects of certain chemicals and their vapors can have harmful results on certain plastics. Aerosol sprays, tuner cleaners, and other chemicals should be avoided.**

#### Cleaning External Plastic Surfaces

The detergent-water solution should be applied sparingly with a stiff, non-metallic, short-bristled brush to work all loose dirt away from the radio. A soft, absorbent, lintless cloth or tissue should be used to remove the solution and dry the radio. Make sure that no water remains entrapped near the connectors, cracks, or crevices.

#### Cleaning Internal Circuit Boards and Components

Isopropyl alcohol may be applied with a stiff, non-metallic, short-bristled brush to dislodge embedded or caked materials located in hard-to-reach areas. The brush stroke should direct the dislodged material out and away from the inside of the radio. Make sure that controls or tunable components are

not soaked with alcohol. Do not use high-pressure air to hasten the drying process since this could cause the liquid to collect in unwanted places. Upon completion of the cleaning process, use a soft, absorbent, lintless cloth to dry the area. Do not brush or apply any isopropyl alcohol to the frame, front cover, or back cover.

**Note:** Always use a fresh supply of alcohol and a clean container to prevent contamination by dissolved material (from previous usage).

### 3.3 Safe Handling of CMOS and LDMOS

Complementary metal-oxide semiconductor (CMOS) devices are used in this family of radios. CMOS characteristics make them susceptible to damage by electrostatic or high voltage charges. Damage can be latent, resulting in failures occurring weeks or months later. Therefore, special precautions must be taken to prevent device damage during disassembly, troubleshooting, and repair.

Handling precautions are mandatory for CMOS circuits and are especially important in low humidity conditions. DO NOT attempt to disassemble the radio without first referring to the CMOS CAUTION paragraph in the Disassembly and Reassembly section of the manual.



WARNING

**CAUTION: This radio contains static-sensitive devices. Do not open the radio unless you are properly grounded. Take the following precautions when working on this unit:**

- Store and transport all CMOS devices in conductive material so that all exposed leads are shorted together. Do not insert CMOS devices into conventional plastic "snow" trays used for storage and transportation of other semiconductor devices.
- Ground the working surface of the service bench to protect the CMOS device. We recommend using the Motorola Static Protection Assembly (part number 0180386A82), which includes a wrist strap, two ground cords, a table mat, and a floor mat.
- Wear a conductive wrist strap in series with a 100k resistor to ground. (Replacement wrist straps that connect to the bench top covering are Motorola part number RSX-4015.)
- Do not wear nylon clothing while handling CMOS devices.
- Do not insert or remove CMOS devices with power applied. Check all power supplies used for testing CMOS devices to be certain that there are no voltage transients present.
- When straightening CMOS pins, provide ground straps for the apparatus used.
- When soldering, use a grounded soldering iron.
- If at all possible, handle CMOS devices by the package and not by the leads. Prior to touching the unit, touch an electrical ground to remove any static charge that you may have accumulated. The package and substrate may be electrically common. If so, the reaction of a discharge to the case would cause the same damage as touching the leads.

### 3.4 General Repair Procedures and Techniques

#### Parts Replacement and Substitution

When damaged parts are replaced, identical parts should be used. If the identical replacement component is not locally available, check the parts list for the proper Motorola part number and order the component from the nearest Motorola Communications parts center listed in the Piece Parts Availability section of this manual (See Chapter 1). You also need to review Motorola's Rework and Repair Technical Reference manual, P/N 6880309G53, which can be ordered from AAD at 1-800-422-4210.

#### Rigid Circuit Boards

The family of radios uses bonded, multi-layer, printed circuit boards. Since the inner layers are not accessible, some special considerations are required when soldering and unsoldering components.

The printed-through holes may interconnect multiple layers of the printed circuit. Therefore, care should be exercised to avoid pulling the plated circuit out of the hole.

When soldering near the 20-pin and 40-pin connectors:

- Avoid accidentally getting solder in the connector.
- Be careful not to form solder bridges between the connector pins.
- Closely examine your work for shorts due to solder bridges.
- Do not exceed 210 degrees C when reworking boards.
- Do not exceed 5 degrees temperature ramp rate.

### Flexible Circuits

The flexible circuits are made from a different material than the rigid boards and different techniques must be used when soldering. Excessive prolonged heat on the flexible circuit can damage the material. Avoid excessive heat and excessive bending.

For parts replacement, use the ST-1087 R1319A Temperature-Controlled Solder Station with a 600-700 degree tip for OMPAC (BGA) CSP, micro BGA and connectors. Use digital tweezers for all other component. Use small diameter solder such as ST-633. The smaller size solder will melt faster and require less heat to be applied to the circuit.

To replace a component on a flexible circuit:

1. Grasp the edge of the flexible circuit with seizers (hemostats) near the part to be removed.
2. Pull gently.
3. Apply the tip of the soldering iron to the component connections while pulling with the seizers.

**Note:** Do not attempt to puddle out components. Prolonged application of heat may damage the flexible circuit.

### Chip Components

Use either the RLN-4062 R1319A Chipmaster Hot-Air Repair Station or the Motorola 0180381B45 Repair Station R1364a digital heated tweezer system for chip component replacement. When using the 0180381B45 Repair Station, select the TJ-65 mini-thermojet hand piece. On either unit, adjust the temperature control to 700 degrees F. (370 degrees C), and adjust the airflow to a minimum setting. Airflow can vary due to component density.

**To remove a chip component:**

1. Use a hot-air hand piece and position the nozzle of hand piece R1319A approximately 1/8" (0.3 cm) above the component to be removed.
2. Begin applying the hot air. Once the solder reflows, remove the component using the pair of tweezers contained in the SMD tool kit shipped with the R1319A.
3. Using a solder wick (Motorola P/N 6680334B25) and a soldering iron or a power desoldering station, remove the excess solder from the pads.

**To replace a chip component using a soldering iron:**

1. Select the appropriate micro-tipped soldering iron and apply fresh solder paste (Motorola P/N 6680333E72) to one of the solder pads.
2. Using a pair of tweezers, position the new chip component in place while heating the fresh solder.
3. Once solder wicks onto the new component, remove the heat from the solder.
4. Heat the remaining pad with the soldering iron and apply solder until it wicks to the component. If necessary, touch up the first side. All solder joints should be smooth and shiny.

**To replace a chip component using hot air:**

1. Use the hot-air hand piece and reflow the solder on the solder pads to smooth it. For components having two or three solder connections, apply a dot of NO-CLEAN solder paste to the lead joints before removal.
2. Apply a drop of solder paste flux to each pad. For dual leaded devices such as SOICs, TSOPs, and quad leaded devices less than 20 leads, such as PLCCs and QFPs, apply a bead of solder paste.
3. Using a pair of tweezers, position the new component in place. As component is removed, it will carry away excess solder, leaving the ideal amount on the pads for their surface area.
4. Position the hot-air hand piece approximately 1/8" (0.3 cm) above the component and begin applying heat. For an extensive discussion of chip component rework and other technical procedures, order manual 6880309G53 from Motorola AAD.
5. Once the solder wicks to the component, remove the heat and inspect the repair. All joints should be smooth and shiny.

**Shields**

Removing and replacing shields will be done with the R-1070 R1319A station with the temperature control set to approximately 415°F (215°C) [445°F (230°C) maximum].

**To remove the shield:**

1. Place the circuit board in the R-1070's holder.
2. Select the proper heat focus head and attach it to the heater chimney.
3. Add paste flux (Motorola P/N 6680333E71) around the base of the shield.
4. Position the shield under the heat-focus head.
5. Lower the vacuum tip and attach it to the shield by turning on the vacuum pump.
6. Lower the focus head until it is approximately 1/8" (0.3 cm) above the shield.
7. Turn on the heater and wait until the shield lifts off the circuit board.
8. Once the shield is off, turn off the heat, grab the part with a pair of tweezers, and turn off the vacuum pump.
9. Remove the circuit board from the R-1070's circuit board holder.

**To replace the shield:**

1. Add solder to the shield if necessary, using a micro-tipped soldering iron.
2. Rub the soldering iron tip along the edge of the shield to smooth out any excess solder. Use solder wick and a soldering iron to remove excess solder from the solder pads on the circuit board.
3. Place the circuit board back in the R1070's R1319A circuit board holder.
4. Place the shield on the circuit board using a pair of tweezers.
5. Place a small bead of no-clean flux (Motorola P/N 6680333E71) around the tinned surface.
6. Position the heat-focus head over the shield and lower it to approximately 1/8" (0.3 cm) above the shield.
7. Turn on the heater and wait for the solder to reflow. The R1319A will record removal time, add 30 to 40 seconds for replacement.
8. Once complete, turn off the heat, raise the heat-focus head and wait approximately one minute for the part to cool.
9. Remove the circuit board and inspect the repair. No cleaning should be necessary.

### 3.5 Recommended Test Tools

Table 3-1 lists the recommended tools used for maintaining this family of radios. These tools are also available from Motorola.

**Table 3-1.** Recommended Test Tools

| Motorola Part Number   | Description   | Application  |
|--|---|--|
| RSX4043  | Torx Driver   | Tighten and remove chassis screws  |
| 6680387A70   | T-6 Torx Bit  | Removable Torx driver bit  |
| WADN4055A<br>6604008K01<br>6604008K02  | Portable soldering station<br>0.4mm replacement tip<br>0.8mm replacement tip  | Digitally controlled soldering Iron<br>For WADN4055A soldering Iron                            |
| 0180386A78   | Illuminated magnifying glass with lens attachment.  |  |
| 0180302E51   | Illuminated Magnification System  | Illuminated and magnification of components  |
| 0180386A82<br><br>6684253C72<br>6680384A98<br>1010041A86<br><br>0180303E45   | Anti-static grounding kit<br><br>Straight prober<br>Brush<br>Solder (RMA type), 63/37, 0.5mm diameter<br>1 lb. spool<br>SMD tool kit (Include with R1319A)  | Used during all radio assembly and disassembly procedures                                      |
| R-1321A R1319A   | Shields and surface-mounted component and IC removal/rework station (order all heat-focus heads separately)   | Removal and assembly of surface-mounted integrated circuits and shields. Includes five nozzles |
| 6680334B49<br>6680334B50<br>6680334B51<br>6680334B52<br>6680334B53<br>6680370B51<br>6680370B54<br>6680370B57<br>6680370B58<br>6680371B15<br>6680371B74<br>6680332E45<br>6680332E46 | 0.410" x 0.410"<br>0.430" x 0.430"<br>0.492" x 0.492"<br>0.572" x 0.572"<br>0.670" x 0.790"<br>0.475" x 0.475"<br>0.710" x 0.710"<br>0.245" x 0.245"<br>0.340" x 0.340"<br>0.460" x 0.560"<br>0.470" x 0.570"<br>0.591" x 0.315"<br>0.862" x 0.350" | Heat-focus heads for R-1319A work station  |
| R1364A   | Digital Heated Tweezer System   | Chip component removal   |
| R1427A   | Board Preheater   | Reduces heatsink on multi-level boards   |
| 6680309B53   | Rework Procedures Manual  | Contains Application notes, procedures, and technical references regarding rework equipment    |

### 3.6 Receiver Troubleshooting Chart (200 MHz)

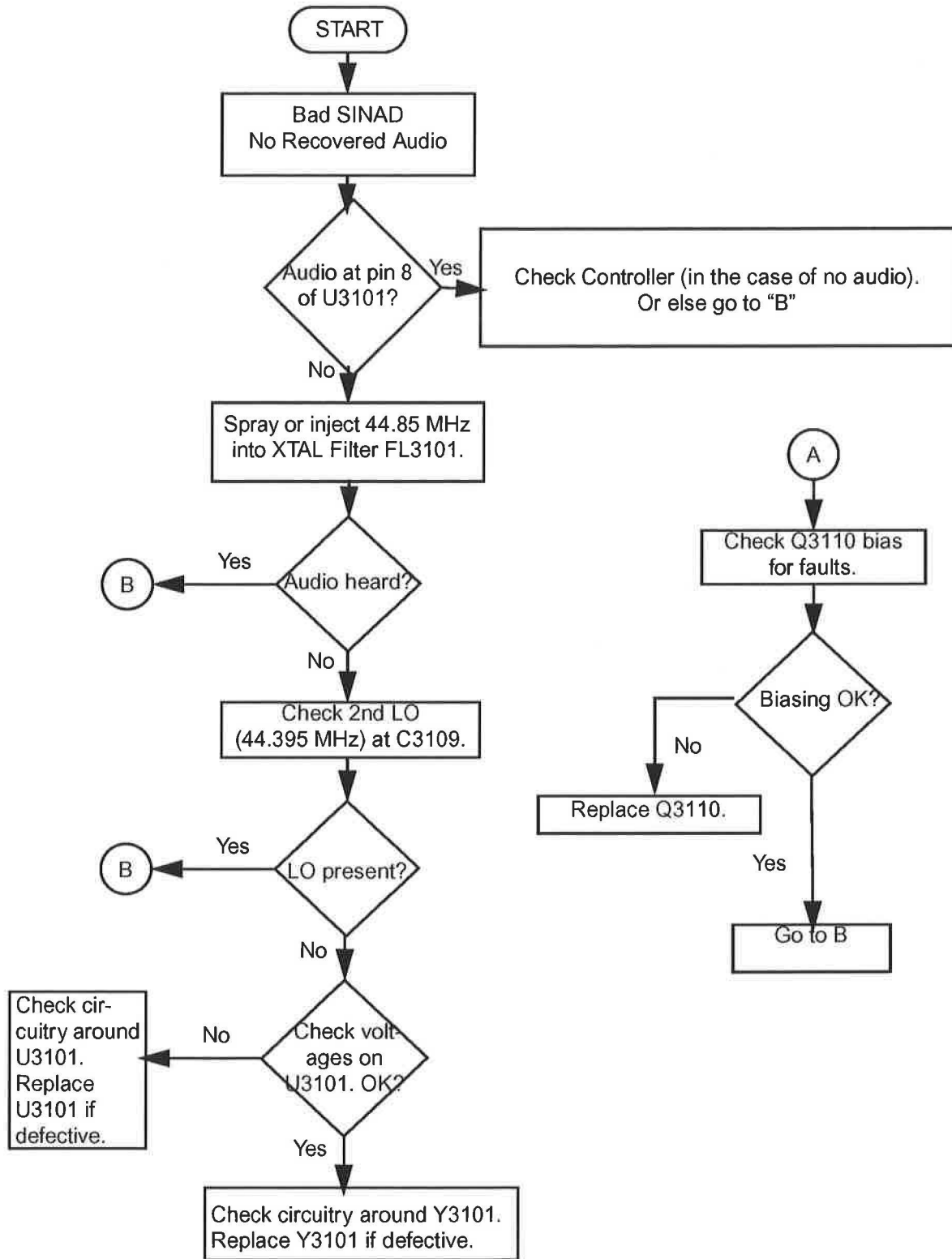

**Troubleshooting Flow Chart for Receiver (200 MHz) (Sheet 1 of 2)**



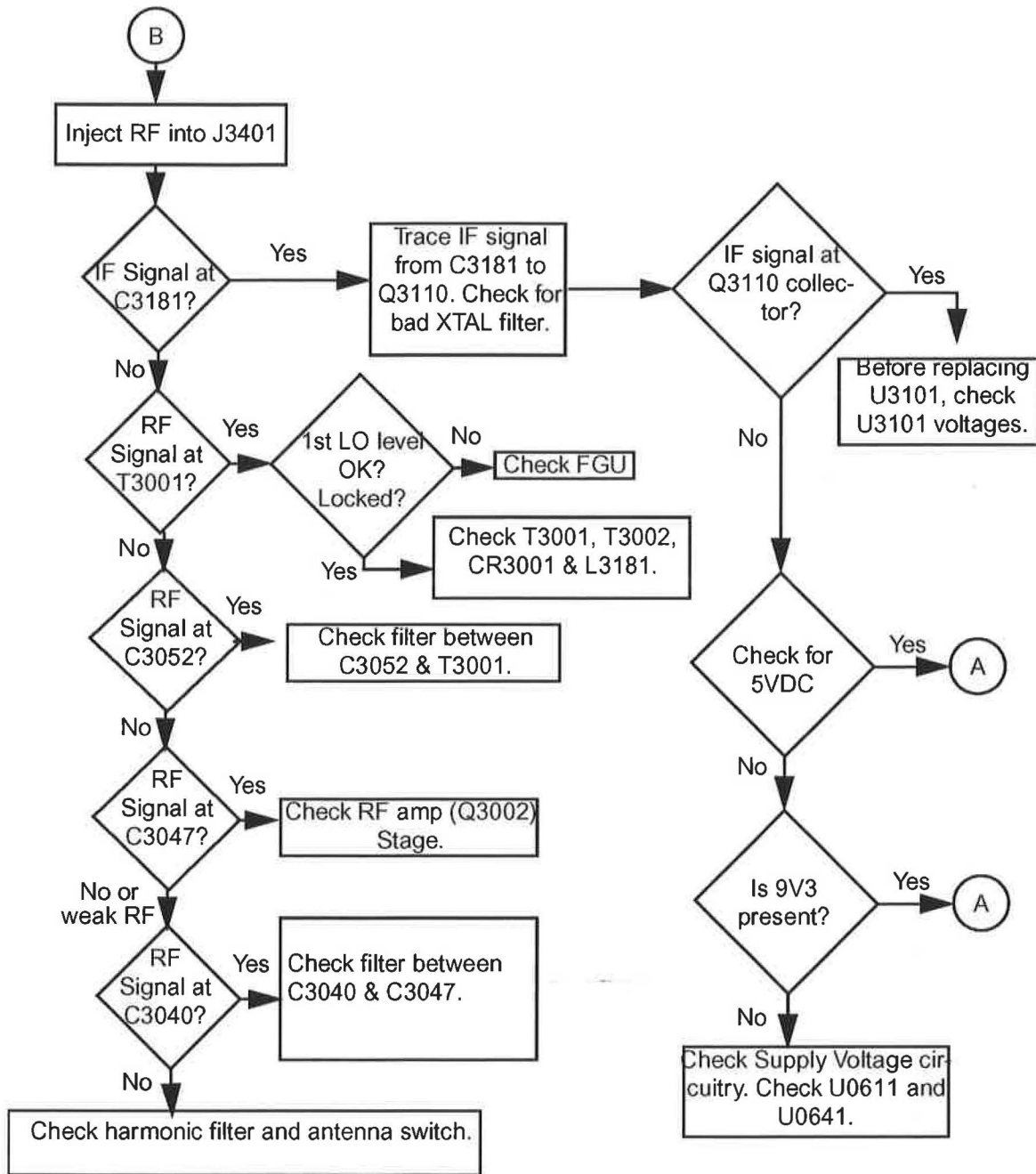

**Troubleshooting Flow Chart for Receiver (200 MHz) (Sheet 2 of 2)**

### 3.7 Receiver Troubleshooting Chart (700 MHz)

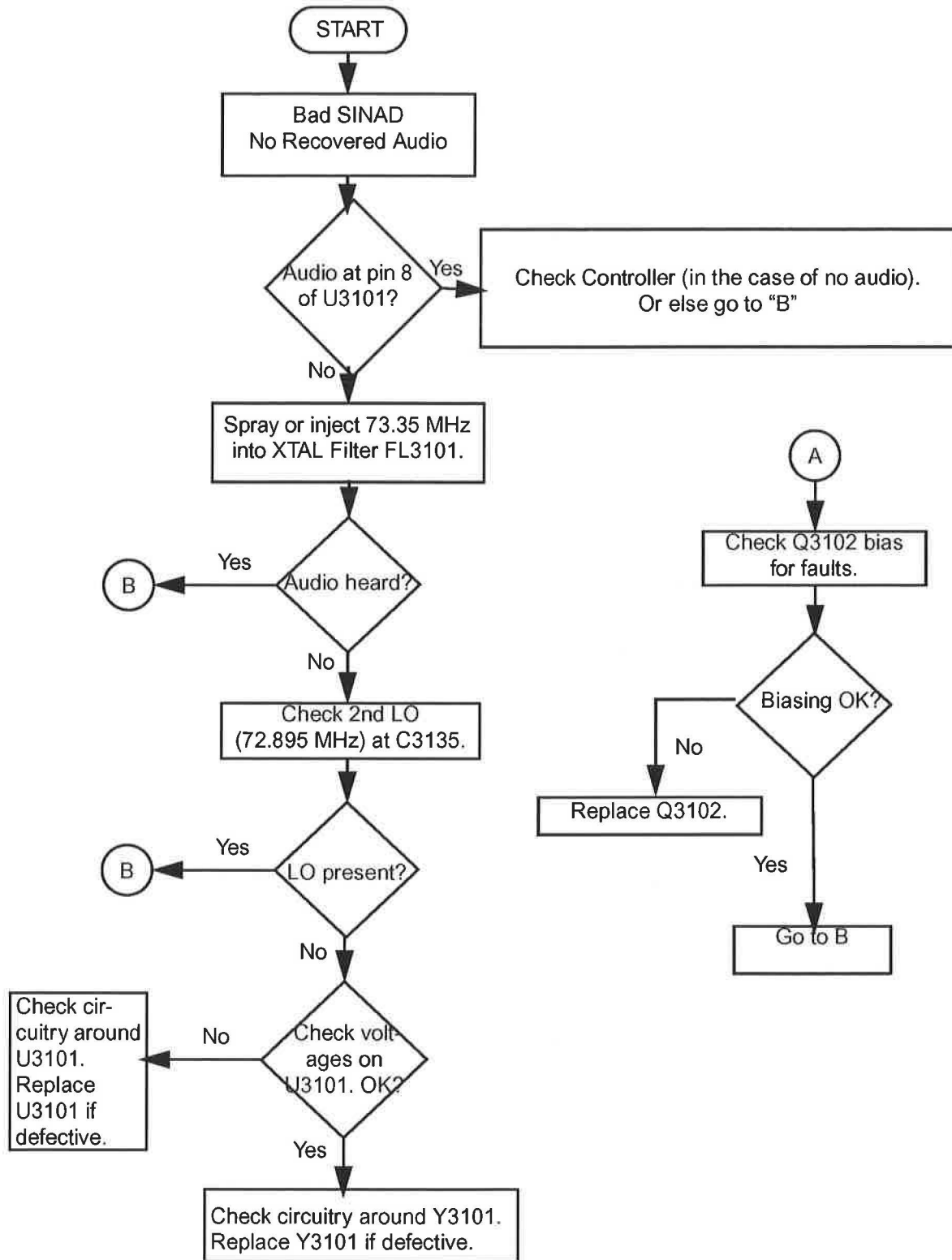

**Troubleshooting Flow Chart for Receiver (700 MHz) (Sheet 1 of 2)**

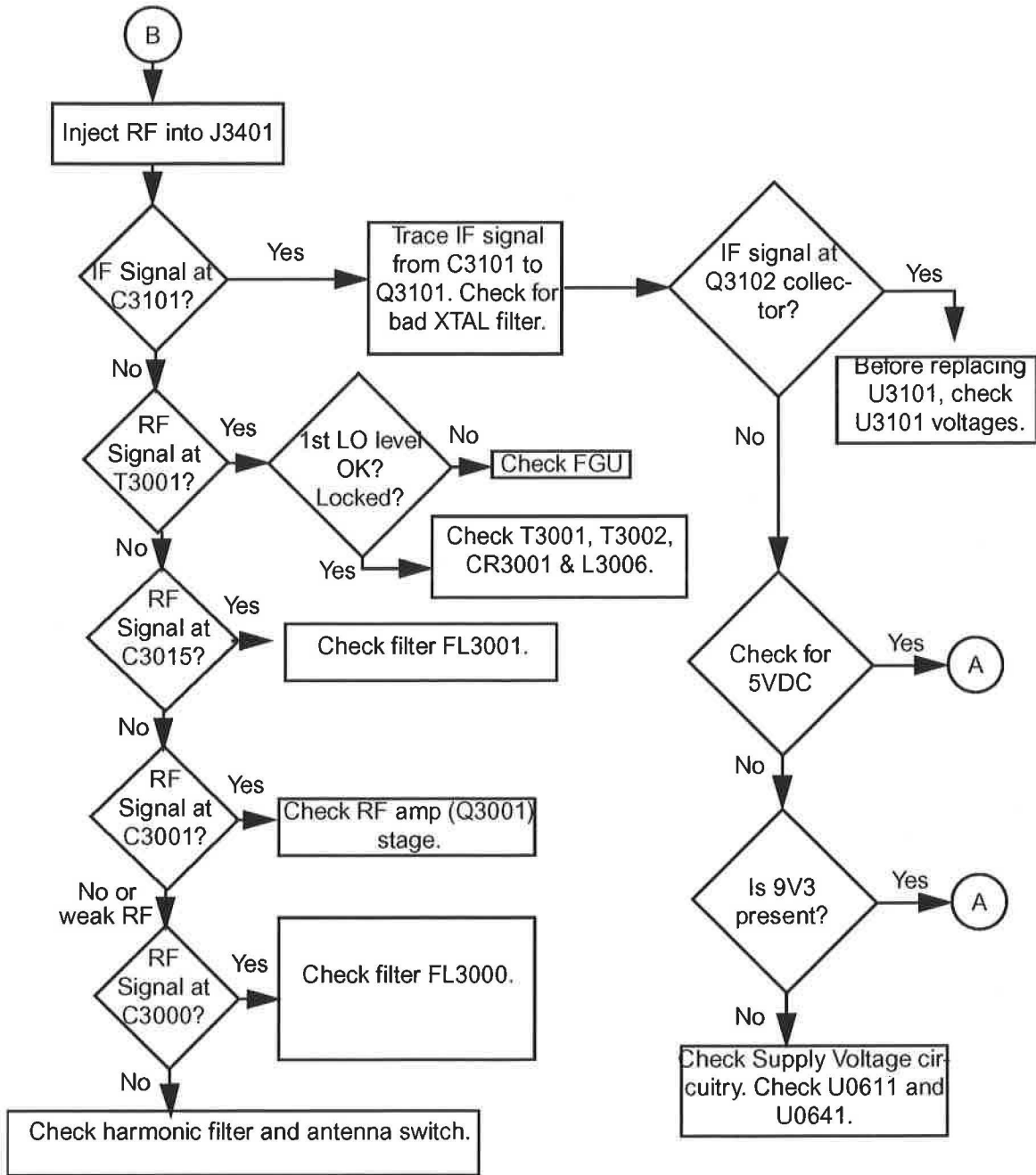

**Troubleshooting Flow Chart for Receiver (700 MHz) (Sheet 2 of 2)**

### 3.8 Transmitter Troubleshooting Chart (200 MHz)

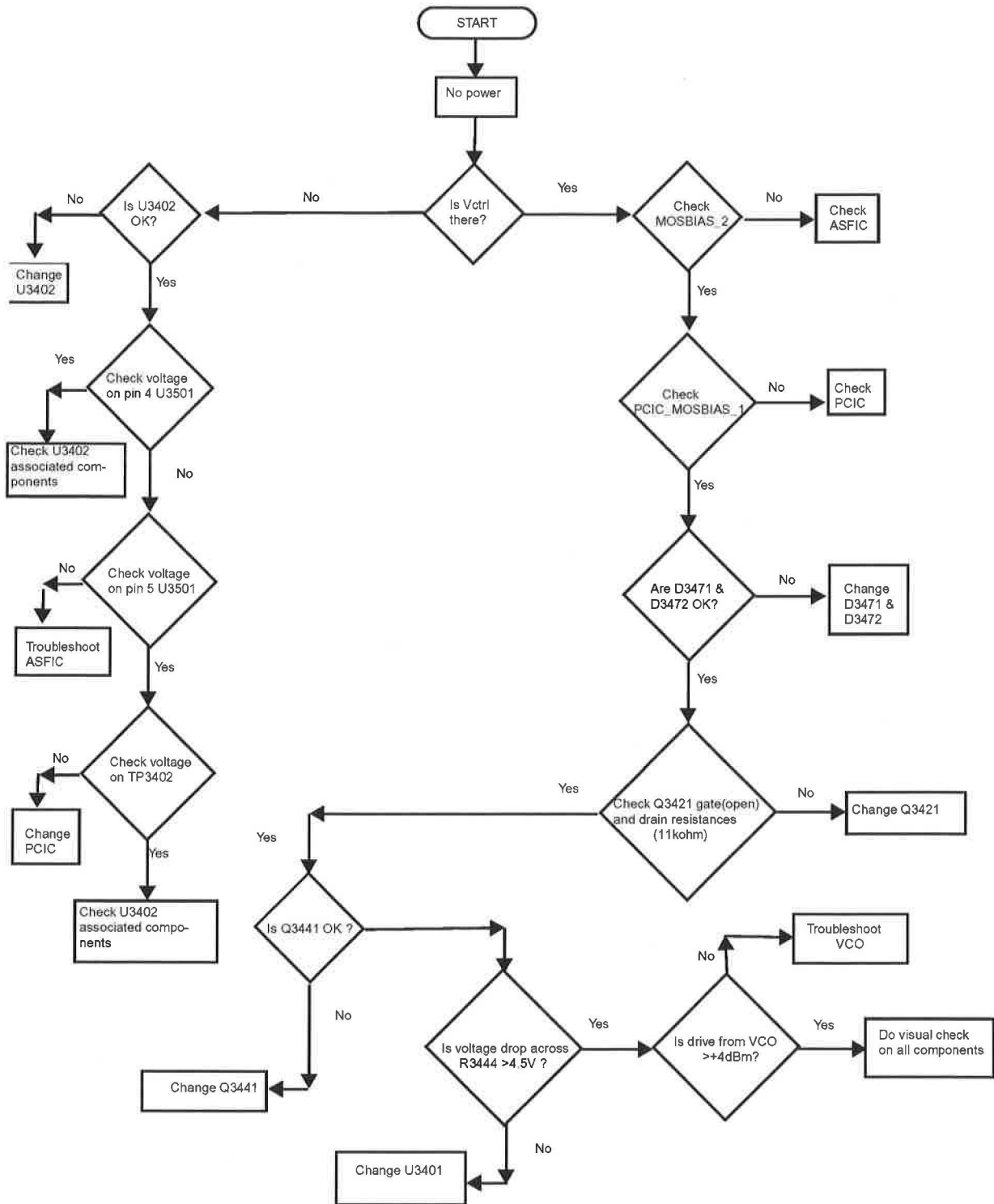

### 3.9 Transmitter Troubleshooting Chart (700 MHz)

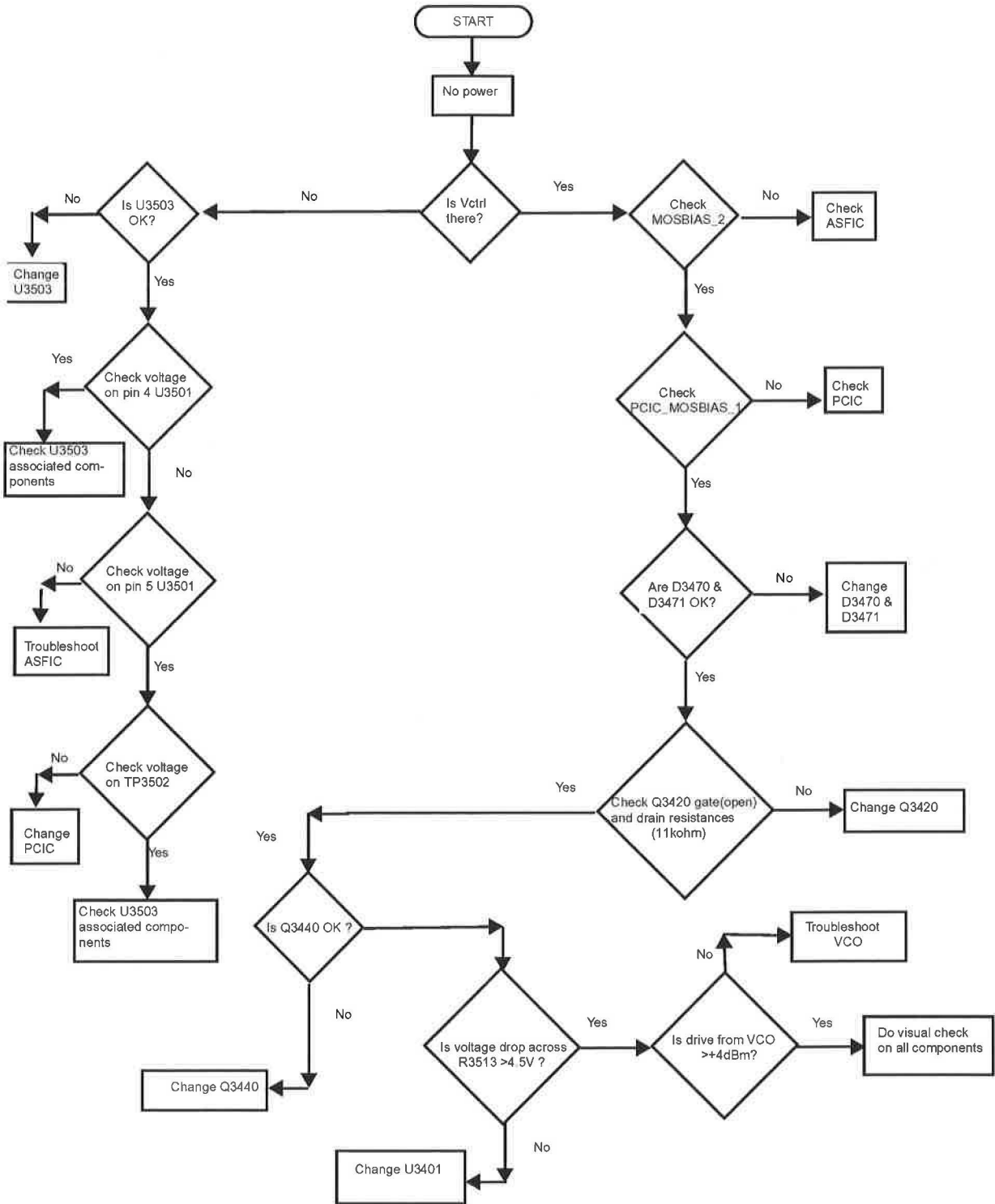

### 3.10 Synthesizer Troubleshooting Chart (200 MHz)

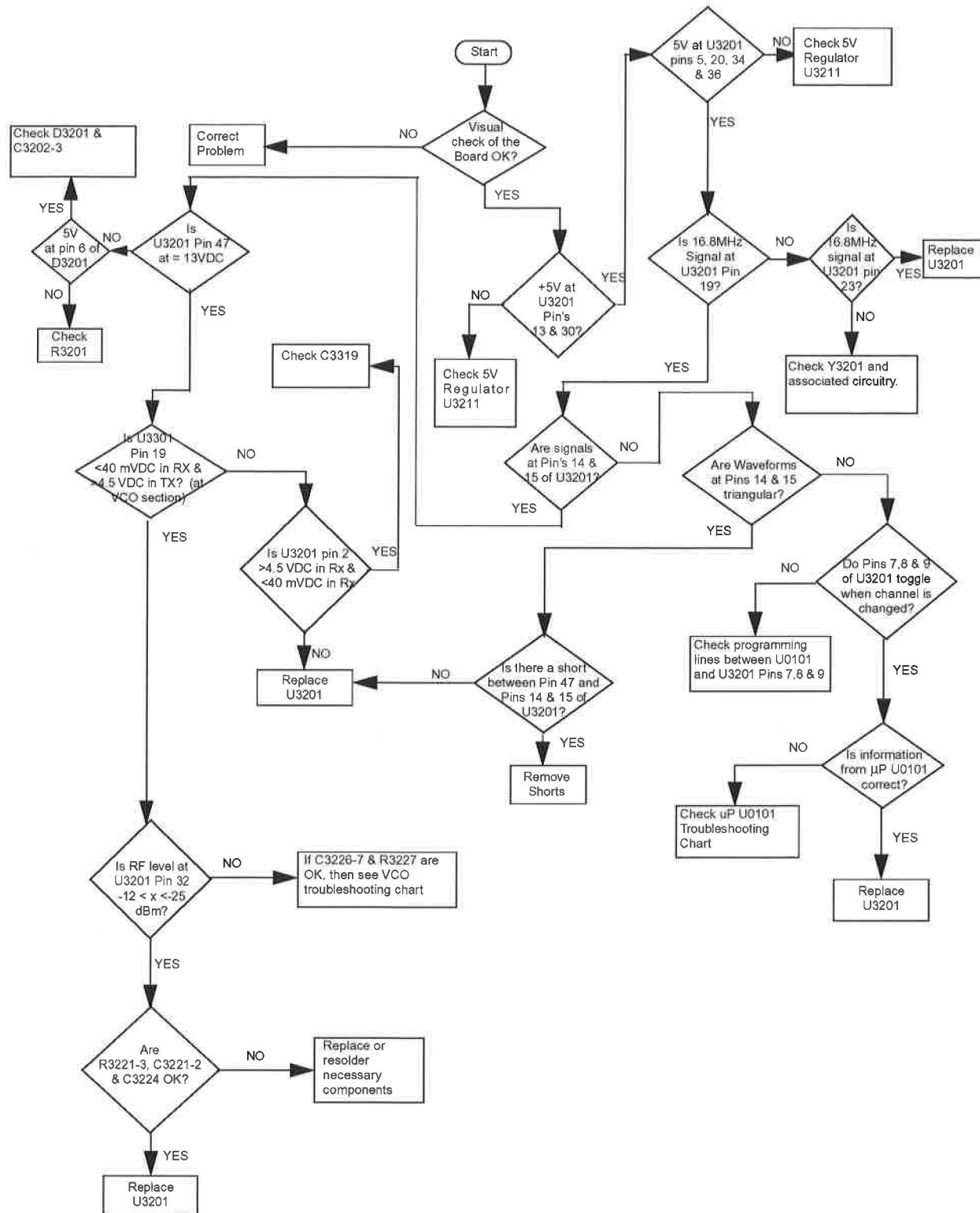

**Troubleshooting Flow Chart for 200 MHz Mobile Synthesizer Section**

### 3.11 Synthesizer Troubleshooting Chart (700 MHz)

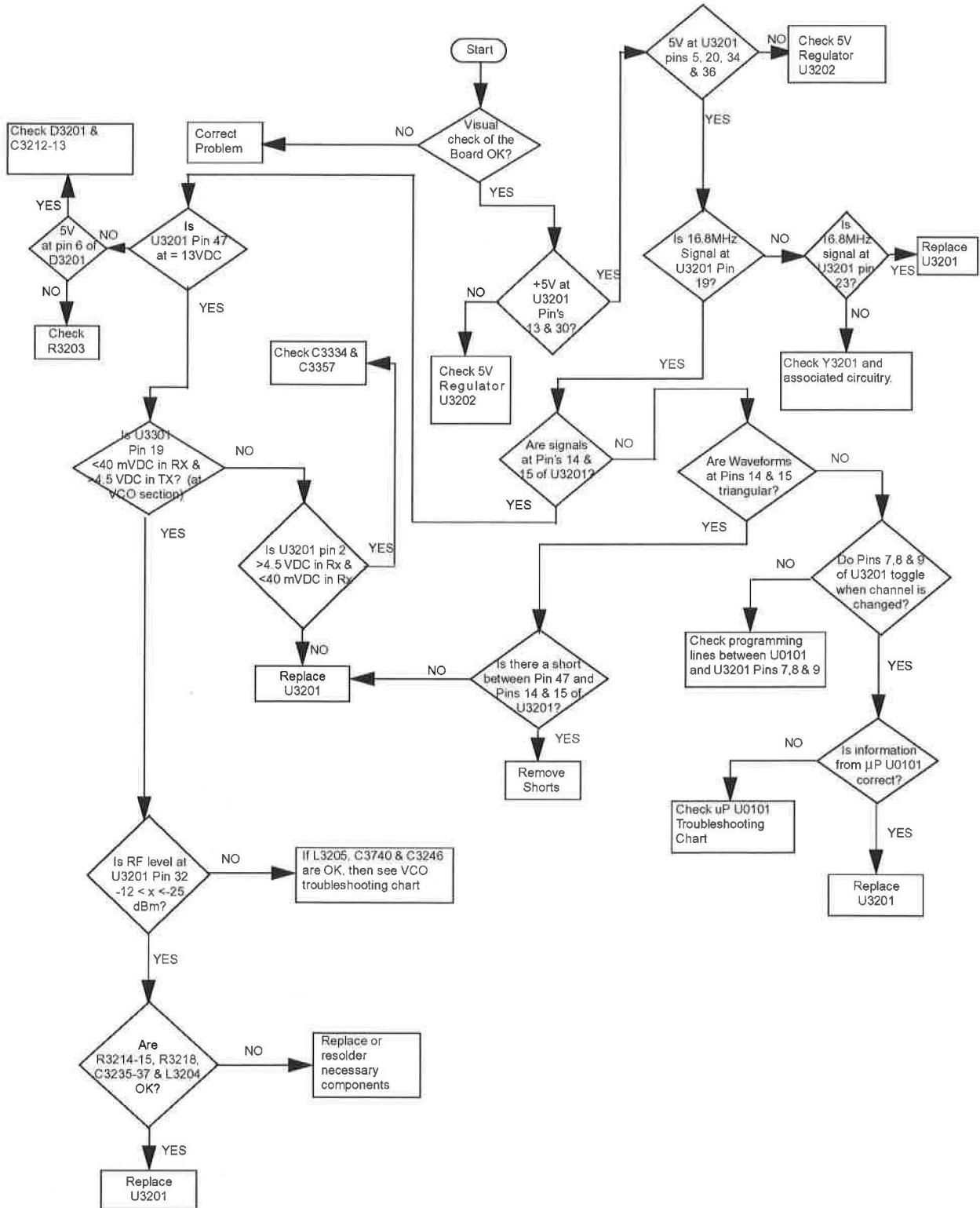

**Troubleshooting Flow Chart for 700 MHz Mobile Synthesizer Section**

This page intentionally left blank



## Chapter 4

# Schematic Diagrams, Overlays, and Parts Lists

### 4.1 Introduction

This chapter provides schematic diagrams, overlays, and parts lists for the radio circuit boards and interface connections.

#### 4.1.1 Notes For All Schematics and Circuit Boards

\* Component is frequency sensitive. Refer to the Electrical Parts List for value and usage.

1. Unless otherwise stated, resistances are in Ohms ( $K = 1000$ ), capacitances are in picofarads (pF) or microfarads ( $\mu F$ ), and inductances are in microhenries ( $\mu H$ ) or nanohenries (nH).
2. DC voltages are measured from point indicated to chassis ground using a Motorola DC multimeter or equivalent. Transmitter measurements should be made with a  $1.2 \mu H$  choke in series with the voltage probe to prevent circuit loading.
3. Reference Designators are assigned in the following manner:

##### Radio Main Board

|           |                                   |
|-----------|-----------------------------------|
| 0100      | Controller Microprocessor Section |
| 0200      | Audio and ASFIC                   |
| 0600      | Power Supply                      |
| 0800-0900 | Control Head                      |
| 3000      | Receiver Front End                |
| 3100      | Receiver Back End                 |
| 3200      | Fractional-N Synthesizer          |
| 3300      | VCO                               |
| 3400      | TX RF Power Amplifier             |
| 3500      | TX Power Control                  |

##### PassPort Trunking Controller Board

|     |                              |
|-----|------------------------------|
| 600 | PassPort Trunking Controller |
|-----|------------------------------|

4. Interconnect Tie Point Legend:

|        |   |                                 |
|--------|---|---------------------------------|
| UNSWB+ | = | Unswitched Battery Voltage      |
| SWB+   | = | Switched Battery Voltage        |
| R5     | = | Receiver Five Volts             |
| CLK    | = | Clock                           |
| Vdda   | = | Regulated 5 Volts (for analog)  |
| Vddd   | = | Regulated 5 Volts (for digital) |
| CSX    | = | Chip Select Line                |
| SYN    | = | Synthesizer                     |
| VSF    | = | Voltage Super Filtered          |
| VR     | = | Voltage Regulator               |

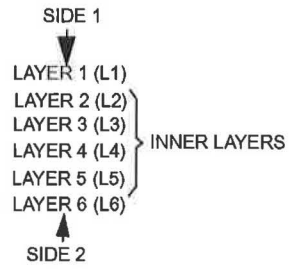

6-LAYER CIRCUIT  
BOARD DETAIL VIEWING  
COPPER STEPS IN PROPER  
LAYER SEQUENCE

### 3.12 VCO Troubleshooting Chart (200 MHz)

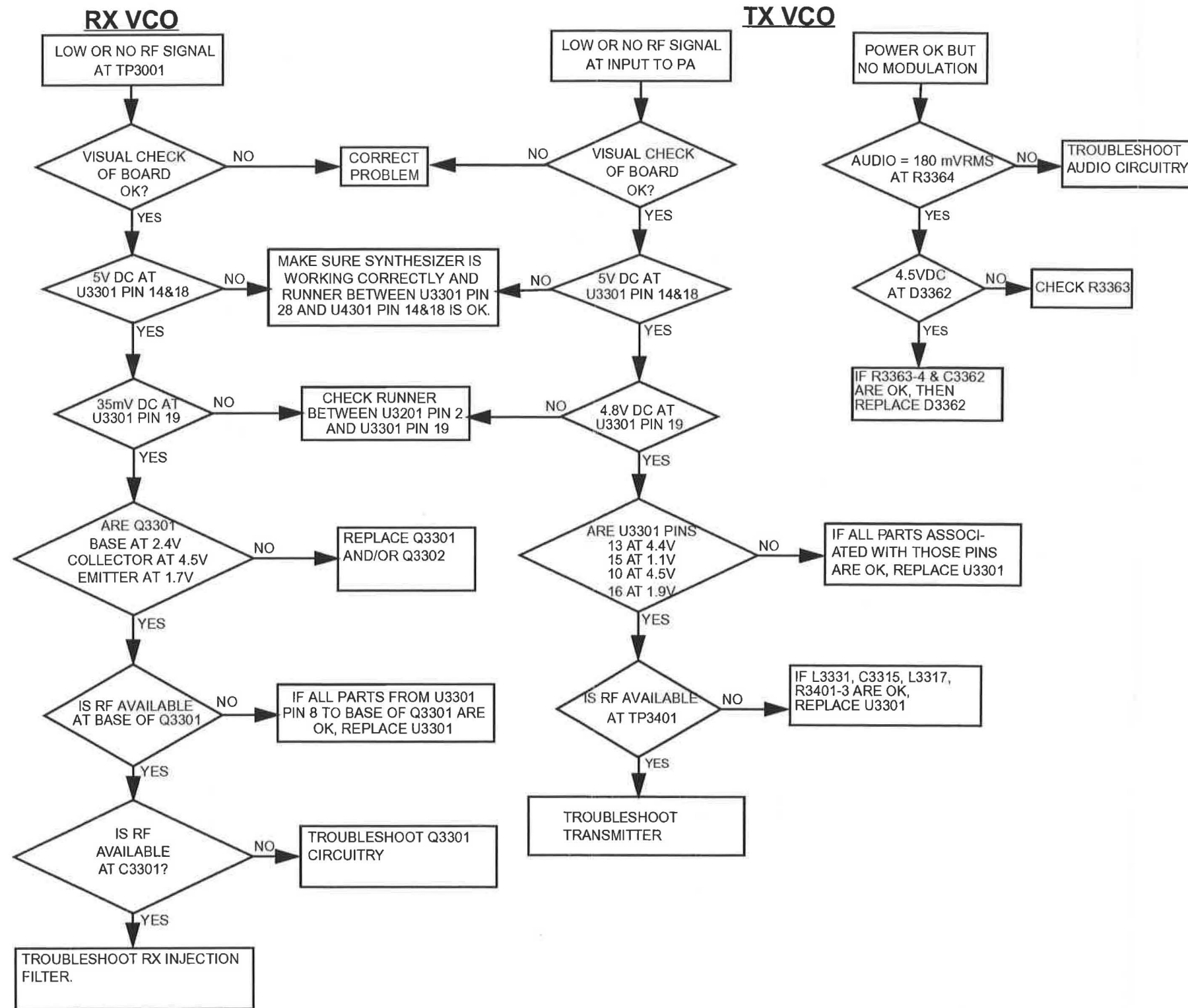

### 3.13 VCO Troubleshooting Chart (700 MHz)

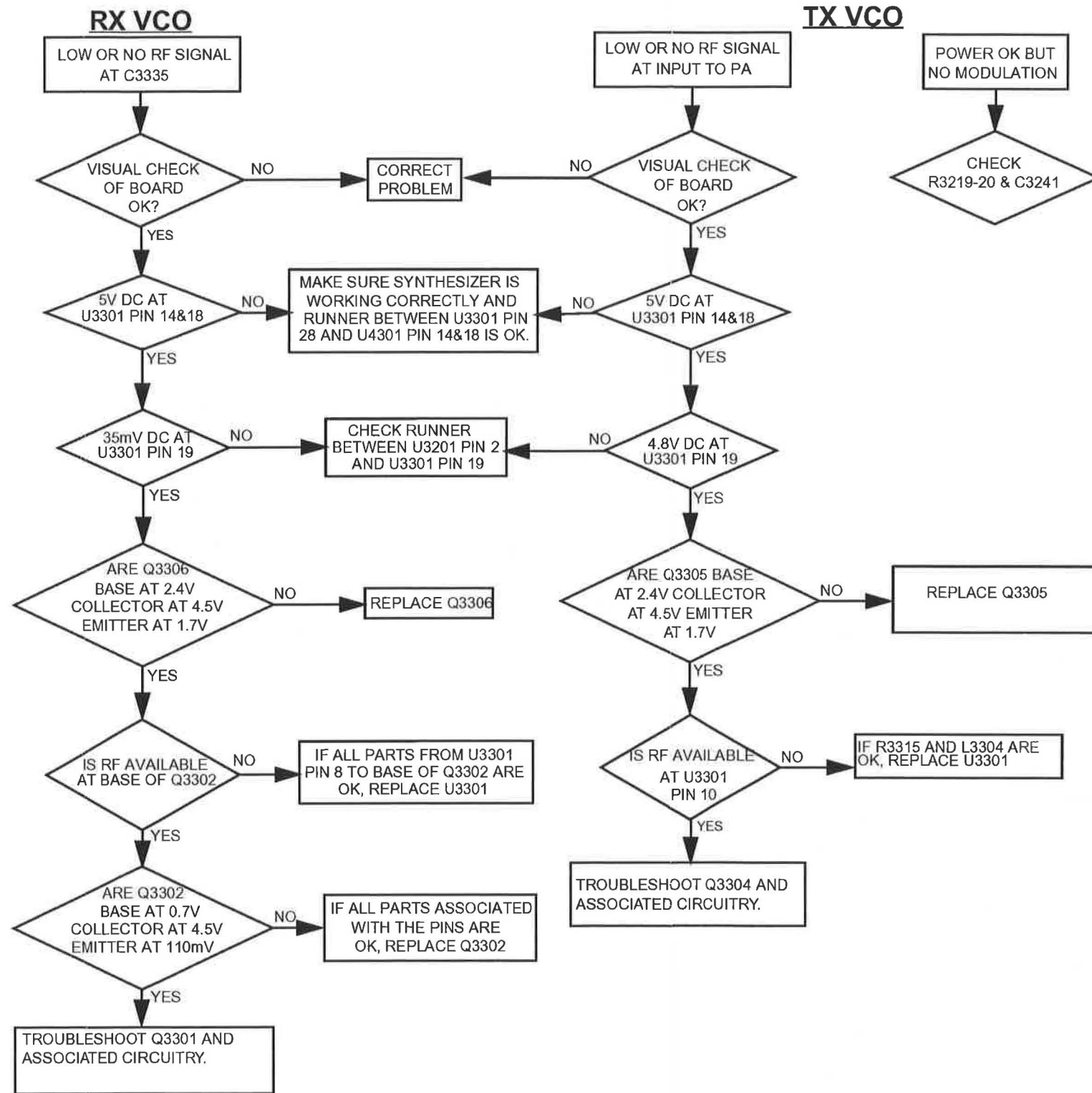

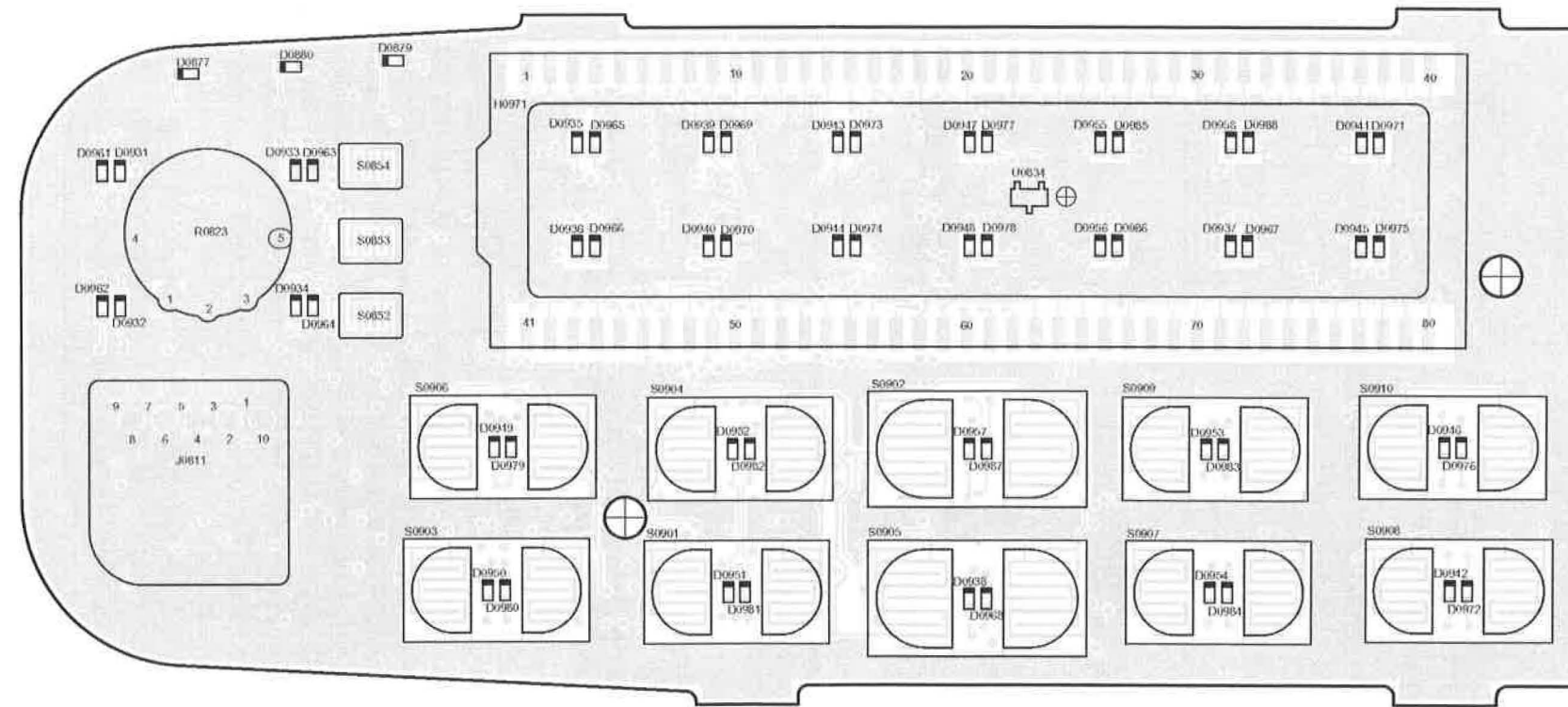

ZWG0130138

Figure 4-1. CDM1550•LS+ Control Head Top Overlay

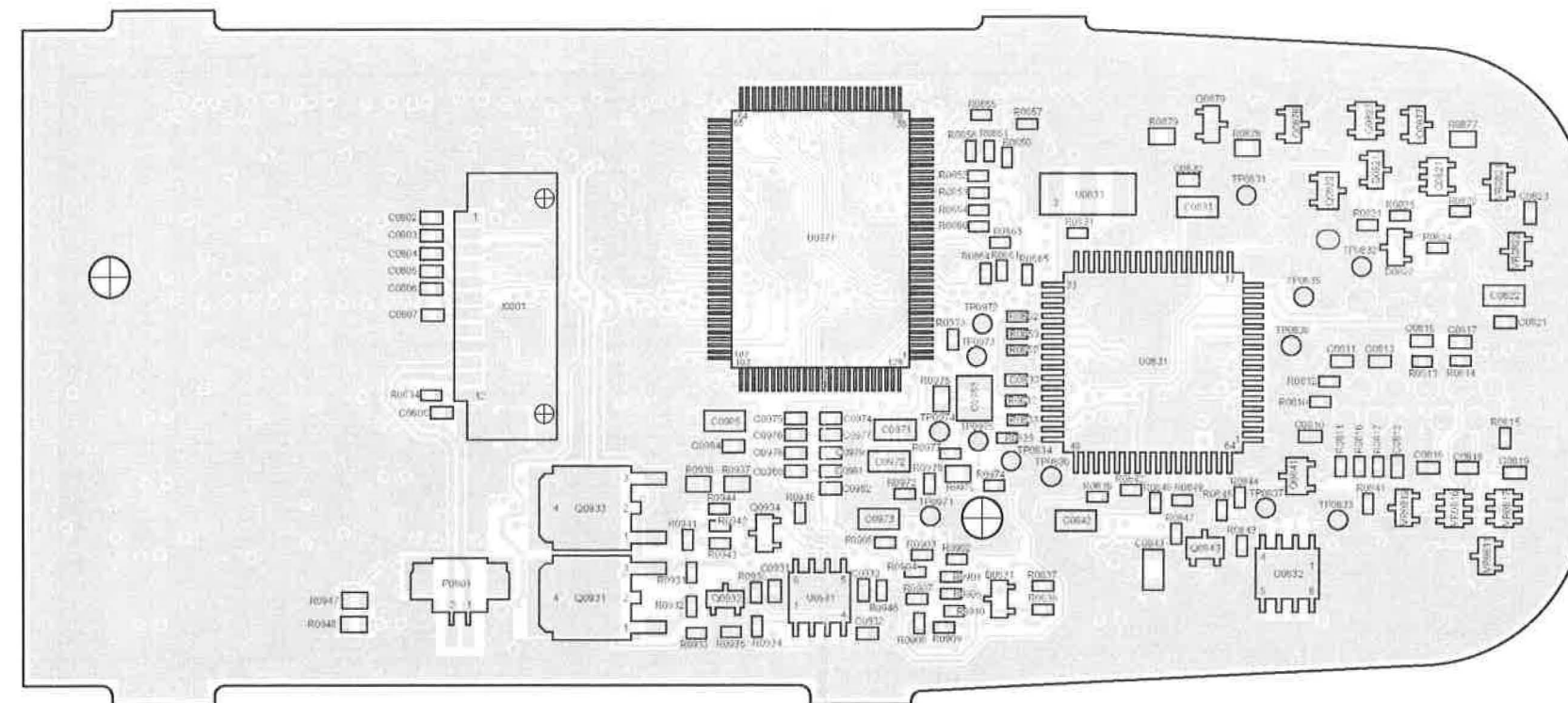

ZWG0130137

Figure 4-2. CDM1550•LS<sup>+</sup> Control Head Bottom Overlay

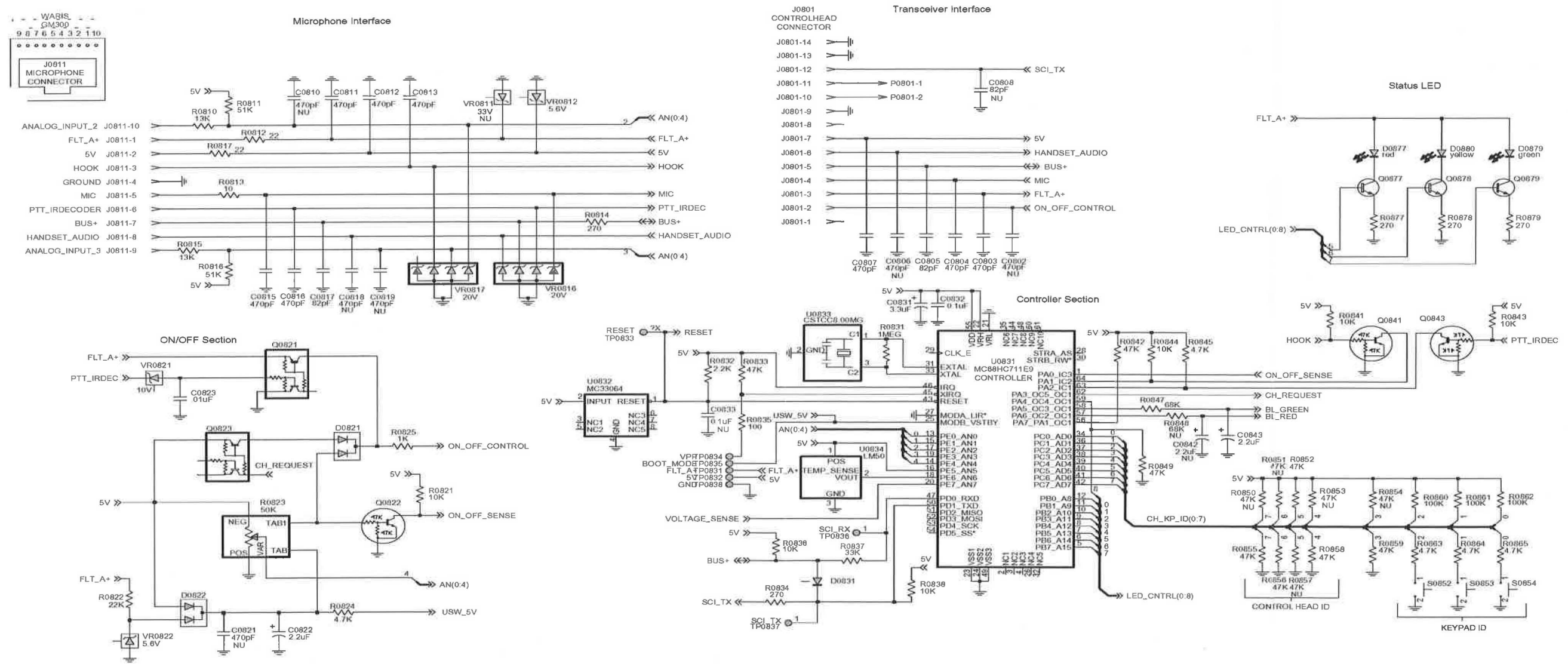

ZWG0130241

Figure 4-3. CDM1550-LS+ Control Head Schematic Diagram

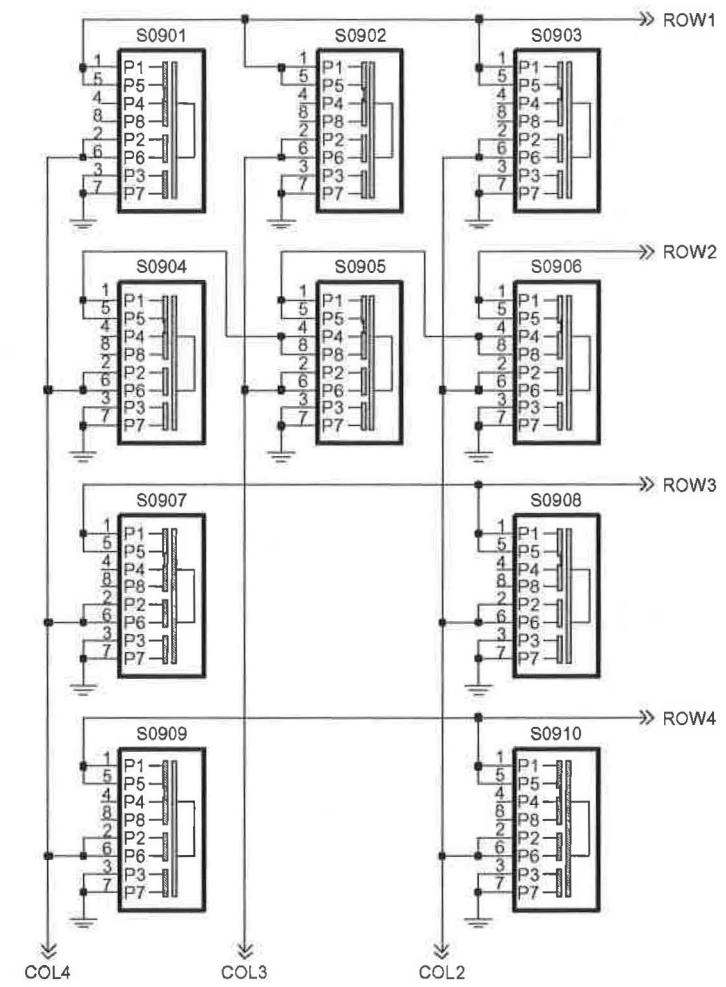
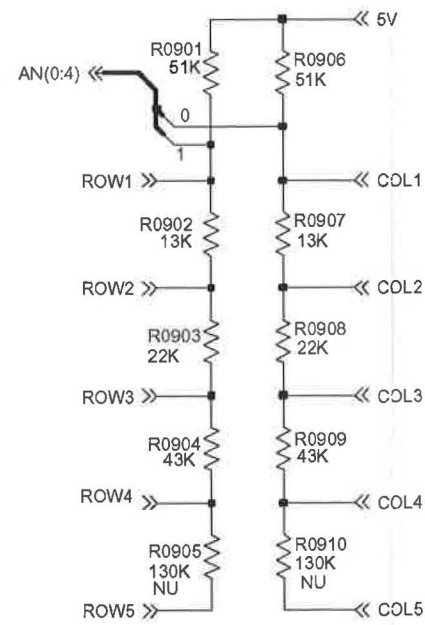
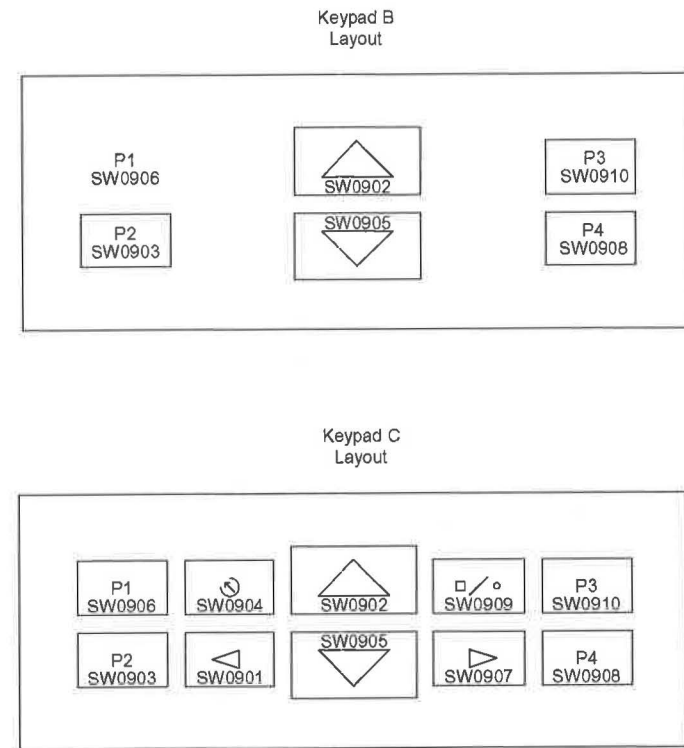

ZWG0130242

Figure 4-4. CDM1550-LS+ Control Head Keypad Schematic



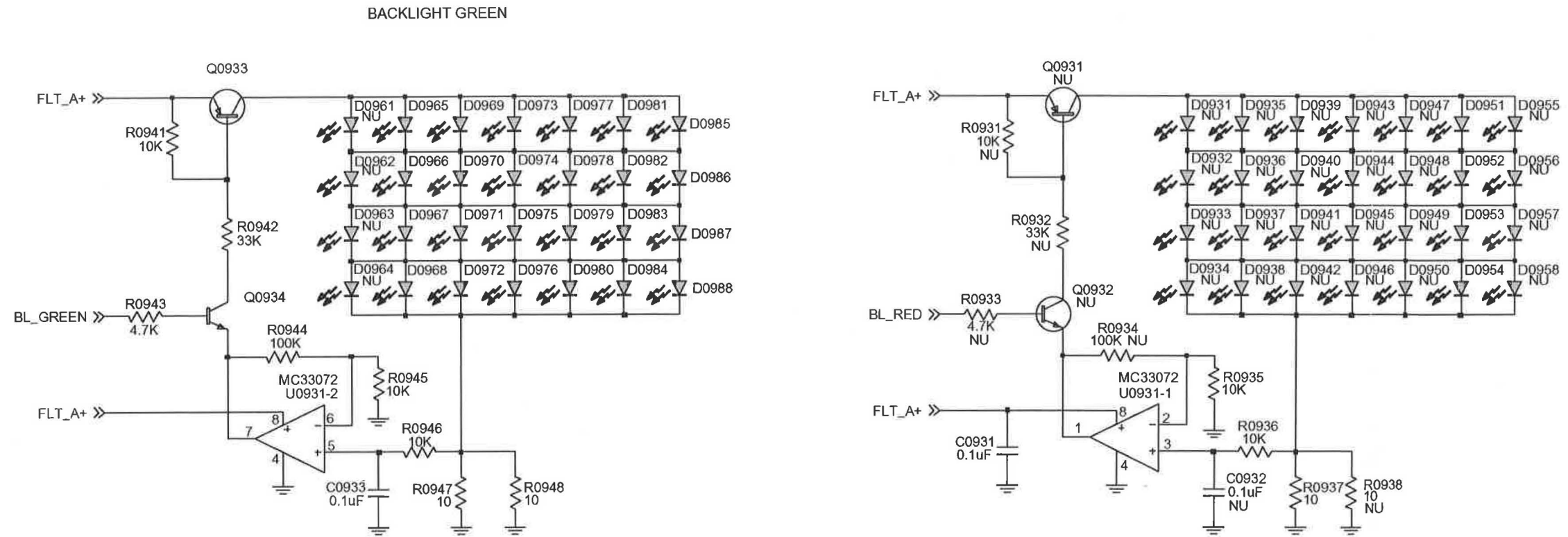

ZWG0130243

Figure 4-5. CDM1550•LS<sup>+</sup> Control Head Backlight Schematic

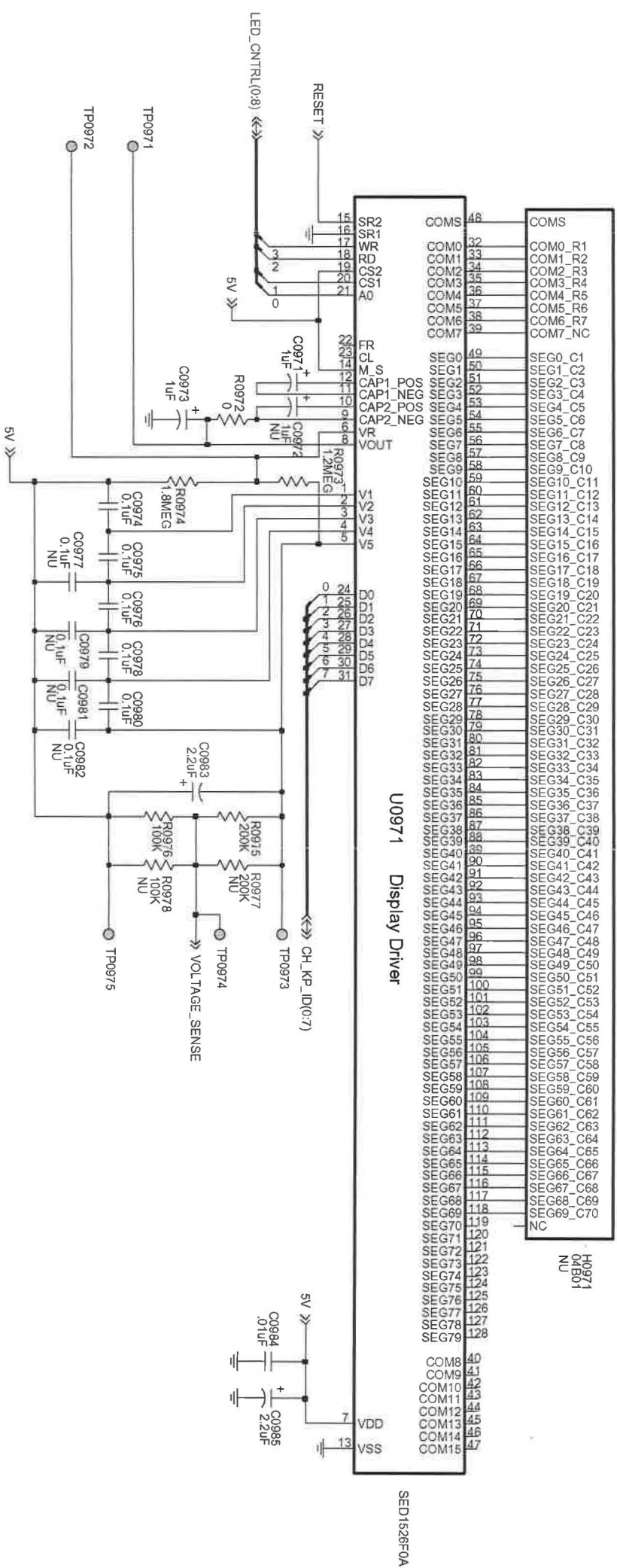

Figure 4-6. CDM1550-LS+ Control Head Display Schematic

CDM1550\*LS<sup>+</sup> Control Head Parts List

| Reference Designator | Motorola Part No. | Description   |
|----------------------|-------------------|---------------|
| C0803                | 2113741F17        | 470pF         |
| C0804                | 2113741F17        | 470pF         |
| C0805                | 2113740F49        | 100pF         |
| C0807                | 2113741F17        | 470pF         |
| C0811                | 2113741F17        | 470pF         |
| C0812                | 2113741F17        | 470pF         |
| C0813                | 2113741F17        | 470pF         |
| C0815                | 2113741F17        | 470pF         |
| C0816                | 2113741F17        | 470pF         |
| C0817                | 2113740F49        | 82pF          |
| C0822                | 2311049A40        | 2.2uF         |
| C0823                | 2113741F49        | 10nF          |
| C0831                | 2311049A42        | 3.3uF         |
| C0832                | 2113743E20        | 100nF         |
| C0843                | 2311049A40        | 470pF         |
| C0931                | 2113743E20        | 100nF         |
| C0933                | 2113743E20        | 100nF         |
| C0971                | 2311049A07        | 1uF           |
| C0973                | 2311049A07        | 1uF           |
| C0974                | 2113743E20        | 100nF         |
| C0975                | 2113743E20        | 100nF         |
| C0976                | 2113743E20        | 100nF         |
| C0978                | 2113743E20        | 100nF         |
| C0980                | 2113743E20        | 100nF         |
| C0983                | 2311049A09        | 2.2uF         |
| C0984                | 2113741F49        | 10nF          |
| C0985                | 2311049A40        | 2.2 uF        |
| D0821                | 4813833C02        | Dual Schottky |
| D0822                | 4813833C02        | Dual Schottky |
| D0831                | 4880236E05        | Schottky      |
| D0877                | 4886171B01        | LED, Red      |
| D0879                | 4886171B04        | LED, Green    |
| D0880                | 4886171B03        | LED, Yellow   |
| D0951                | 4886171B02        | LED, Orange   |
| D0952                | 4886171B02        | LED, Orange   |
| D0953                | 4886171B02        | LED, Orange   |
| D0954                | 4886171B02        | LED, Orange   |
| D0965                | 4886171B04        | LED, Green    |
| D0966                | 4886171B04        | LED, Green    |
| D0967                | 4886171B04        | LED, Green    |
| D0968                | 4886171B04        | LED, Green    |
| D0969                | 4886171B04        | LED, Green    |
| D0970                | 4886171B04        | LED, Green    |
| D0971                | 4886171B04        | LED, Green    |
| D0972                | 4886171B04        | LED, Green    |
| D0973                | 4886171B04        | LED, Green    |
| D0974                | 4886171B04        | LED, Green    |
| D0975                | 4886171B04        | LED, Green    |
| D0976                | 4886171B04        | LED, Green    |
| D0977                | 4886171B04        | LED, Green    |

| Reference Designator | Motorola Part No. | Description      |
|----------------------|-------------------|------------------|
| D0978                | 4886171B04        | LED, Green       |
| D0979                | 4886171B04        | LED, Green       |
| D0980                | 4886171B04        | LED, Green       |
| D0981                | 4886171B04        | LED, Green       |
| D0982                | 4886171B04        | LED, Green       |
| D0983                | 4886171B04        | LED, Green       |
| D0984                | 4886171B04        | LED, Green       |
| D0985                | 4886171B04        | LED, Green       |
| D0986                | 4886171B04        | LED, Green       |
| D0987                | 4886171B04        | LED, Green       |
| D0988                | 4886171B04        | LED, Green       |
| J801                 | 0902636Y02        | 12-pin connector |
| J811                 | 2864287B01        | 10-pin connector |
| P0801                | 2809926G01        | 2-pin connector  |
| Q0821                | 4805921T02        | Transistor, dual |
| Q0822                | 4880048M01        | Transistor, NPN  |
| Q0823                | 4805921T02        | Transistor, dual |
| Q0841                | 4880048M01        | Transistor, NPN  |
| Q0843                | 4880048M01        | Transistor, NPN  |
| Q0877                | 4813824A10        | Transistor, NPN  |
| Q0878                | 4813824A10        | Transistor, NPN  |
| Q0879                | 4813824A10        | Transistor, NPN  |
| Q0933                | 4813824A08        | Transistor, PNP  |
| Q0934                | 4813824A10        | Transistor, NPN  |
| R0810                | 0662057A76        | 13K              |
| R0811                | 0662057A90        | 51K              |
| R0812                | 0662057A09        | 22               |
| R0813                | 0662057A01        | 10               |
| R0814                | 0662057A35        | 270              |
| R0815                | 0662057A76        | 13K              |
| R0816                | 0662057A90        | 51K              |
| R0817                | 0662057A09        | 22               |
| R0821                | 0662057A73        | 10K              |
| R0822                | 0662057A82        | 24K              |
| R0823                | 1805911V01        | Volume Pot       |
| R0824                | 0662057A65        | 4K               |
| R0825                | 0662057A49        | 1K               |
| R0831                | 0662057B22        | 1M               |
| R0832                | 0662057A57        | 2K               |
| R0833                | 0662057A89        | 47K              |
| R0834                | 0662057A35        | 270              |
| R0835                | 0662057A25        | 100              |
| R0836                | 0662057A73        | 10K              |
| R0837                | 0662057A85        | 33K              |
| R0838                | 0662057A73        | 10K              |
| R0841                | 0662057A73        | 10K              |
| R0842                | 0662057A89        | 47K              |
| R0843                | 0662057A73        | 10K              |
| R0844                | 0662057A73        | 10K              |
| R0845                | 0662057A65        | 4K               |
| R0847                | 0662057A93        | 22               |

| Reference Designator | Motorola Part No. | Description        |
|----------------------|-------------------|--------------------|
| R0849                | 0662057A89        | 47K                |
| R0852*               | 0662057A89        | 47K                |
| R0853                |                   | not used           |
| R0855                | 0662057A89        | 47K                |
| R0856                | 0662057A89        | 47K                |
| R0857                |                   | not used           |
| R0858                | 0662057A89        | 47K                |
| R0859                | 0662057A89        | 47K                |
| R0860                | 0662057A97        | 100K               |
| R0861                | 0662057A97        | 100K               |
| R0862                | 0662057A97        | 100K               |
| R0863                | 0662057A65        | 4K                 |
| R0864                | 0662057A65        | 4K                 |
| R0865                | 0662057A65        | 4K                 |
| R0877                | 0660076A35        | 270                |
| R0878                | 0660076A35        | 270                |
| R0879                | 0660076A35        | 270                |
| R0901                | 0662057A90        | 51K                |
| R0902                | 0662057A76        | 13K                |
| R0903                | 0662057A81        | 22K                |
| R0904                | 0662057A88        | 43K                |
| R0906                | 0662057A90        | 51K                |
| R0907                | 0662057A76        | 13K                |
| R0908                | 0662057A81        | 22K                |
| R0909*               | 0662057A88        | 43K                |
| R0935                | 0662057A73        | 10K                |
| R0936                | 0662057A73        | 10K                |
| R0937                | 0660076A01        | 10                 |
| R0941                | 0662057A73        | 10K                |
| R0942                | 0662057A85        | 33K                |
| R0943                | 0662057A65        | 4K                 |
| R0944                | 0662057A97        | 100K               |
| R0945                | 0662057A73        | 10K                |
| R0946                | 0662057A73        | 10K                |
| R0947                | 0660076A01        | 10                 |
| R0948                | 0660076A01        | 10                 |
| R0972                | 0662057B47        | 0                  |
| R0973                | 0662057B24        | 1.2M               |
| R0974                | 0662057B28        | 1.8M               |
| R0975                | 0662057G29        | 200K               |
| R0976                | 0662057G13        | 100K               |
| U0831                | 5113802A24        | IC                 |
| U0832                | 5113815A02        | Voltage Sensor     |
| U0833                | 4886061B01        | 8 MHz              |
| U0834                | 5185963A15        | Temperature Sensor |
| U0931                | 5113818A03        | IC                 |
| U0971                | 5186158B01        | LCD Driver         |
| VR0812               | 4813830A15        |                    |
| VR0816               | 4805656W09        | Diode, Zener       |
| VR0817               | 4805656W09        | Diode, Zener       |

| Reference Designator | Motorola Part No. | Description |
|----------------------|-------------------|-------------|
| VR0821               | 4813830A23        | Diode, 5.6V |
| VR0822               | 4813830A15        | Diode, 5.6V |

This page intentionally left blank

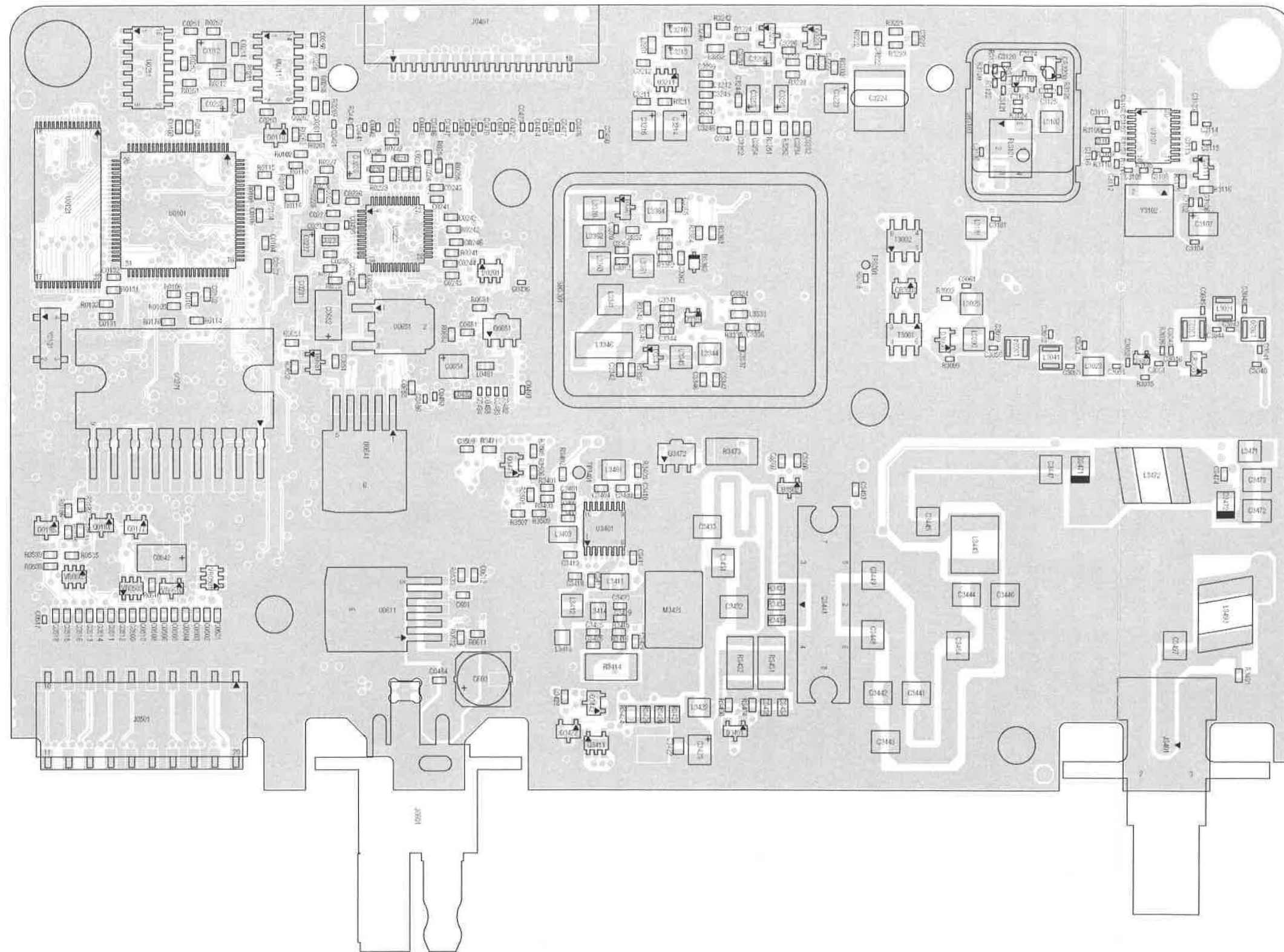

Figure 4-7. 200 MHz Main Board Top Side PCB

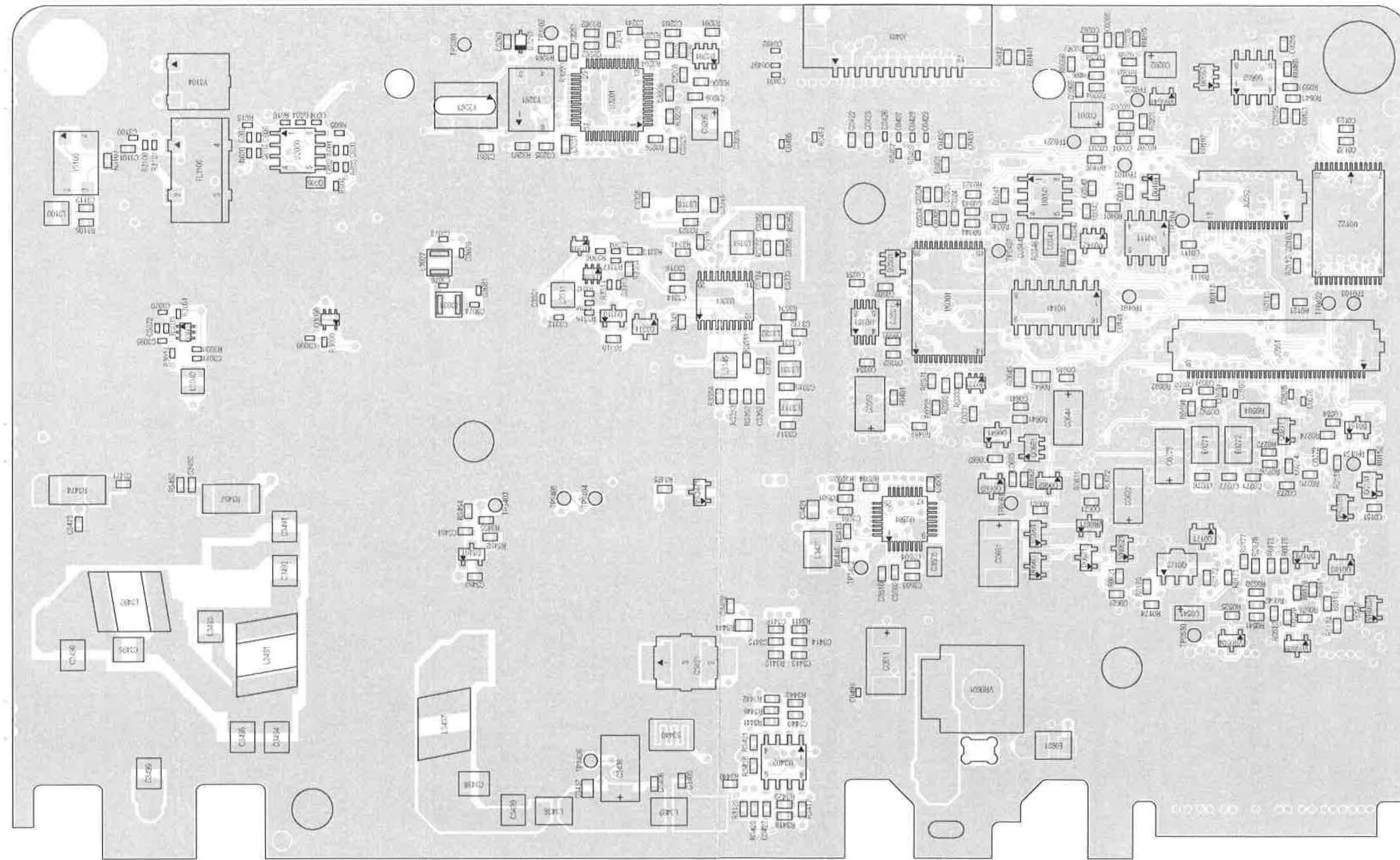

Figure 4-8. 200 MHz Main Board Bottom Side PCB

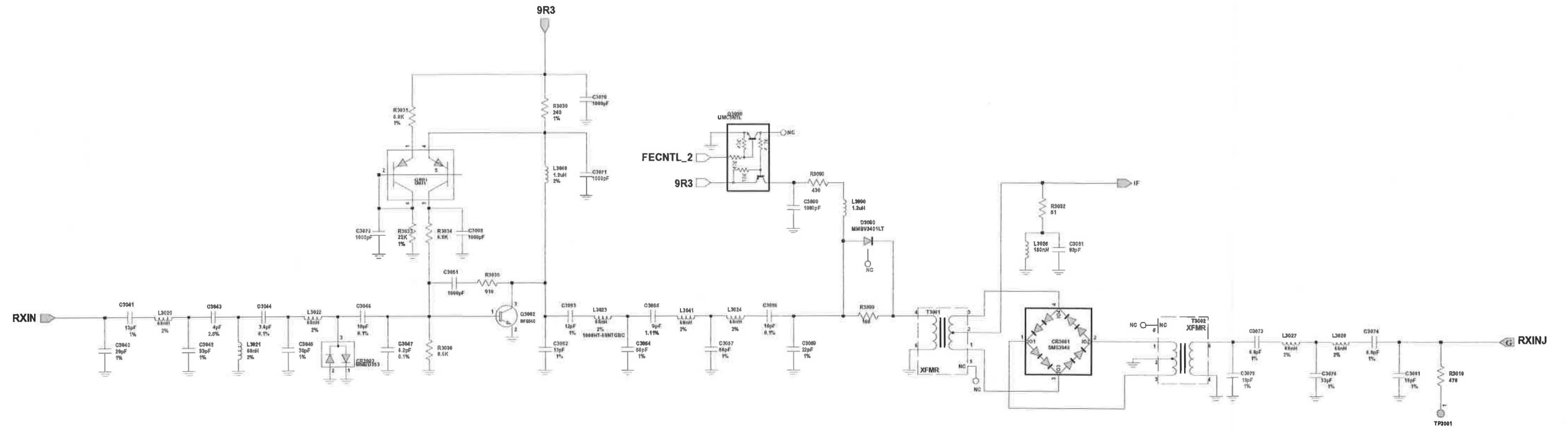

Figure 4-9. 200 MHz Receiver Front End Schematic Diagram

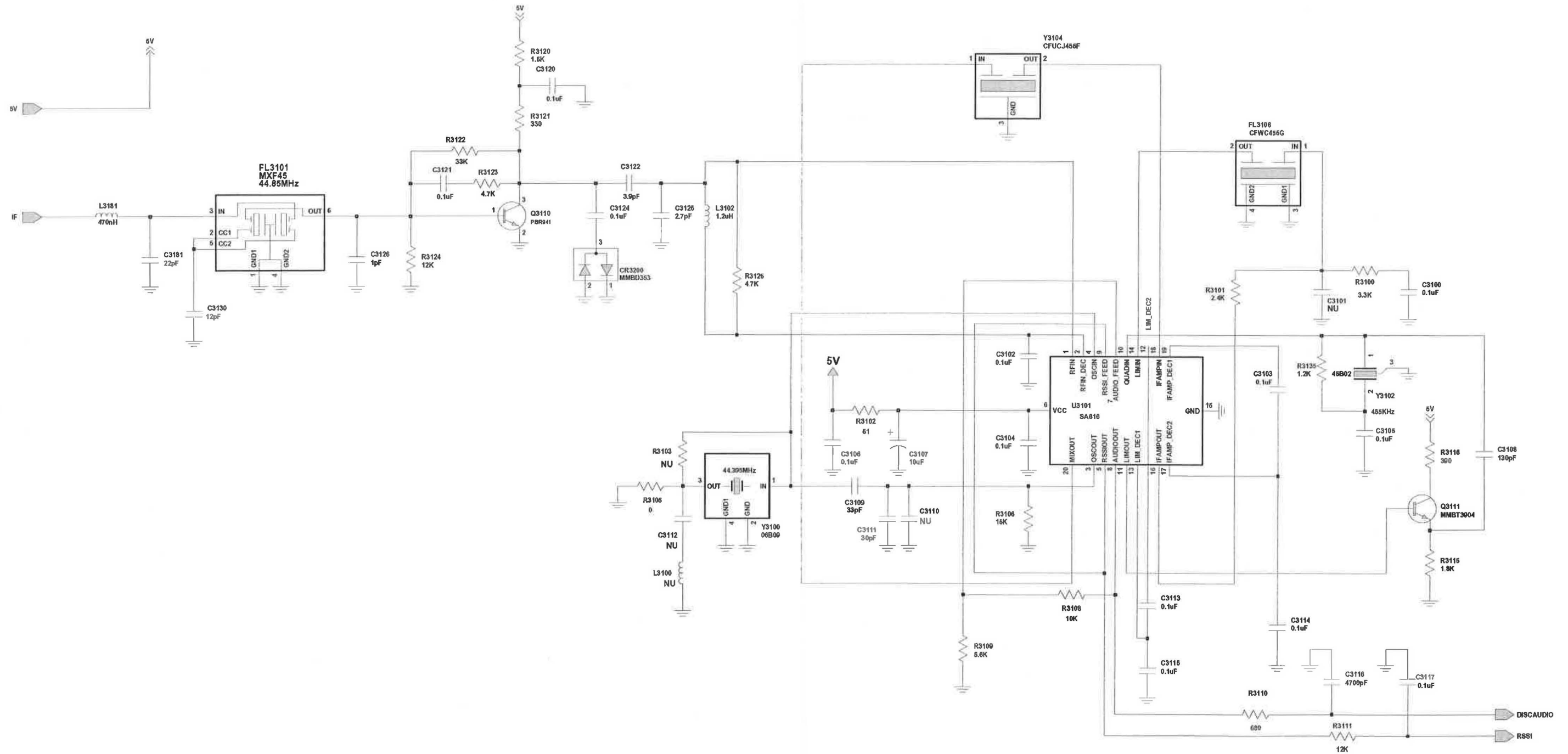

Figure 4-10. 200 MHz Receiver IF Schematic Diagram



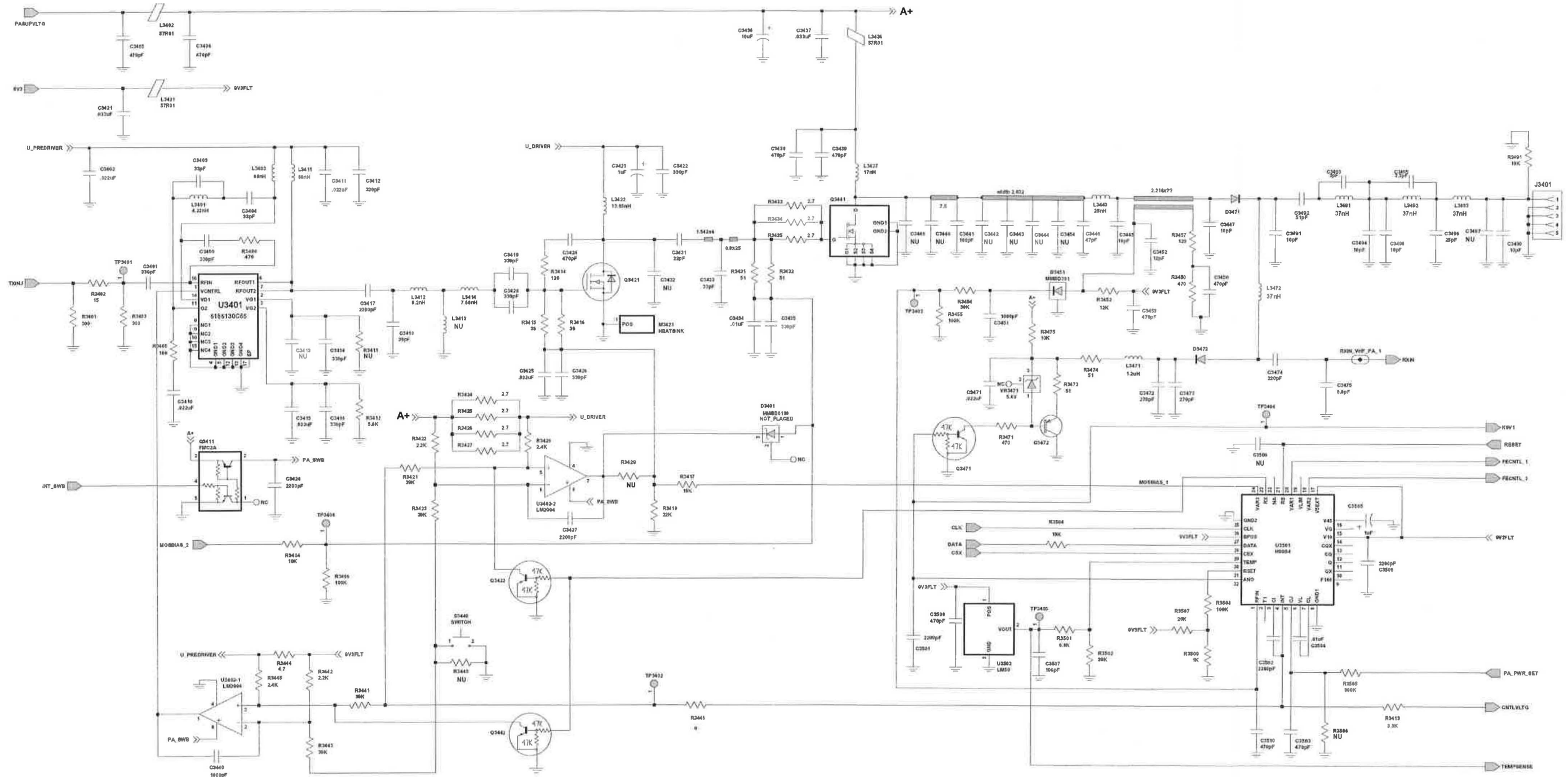

Figure 4-11. 200 MHz Transmitter Power Amplifier Schematic Diagram

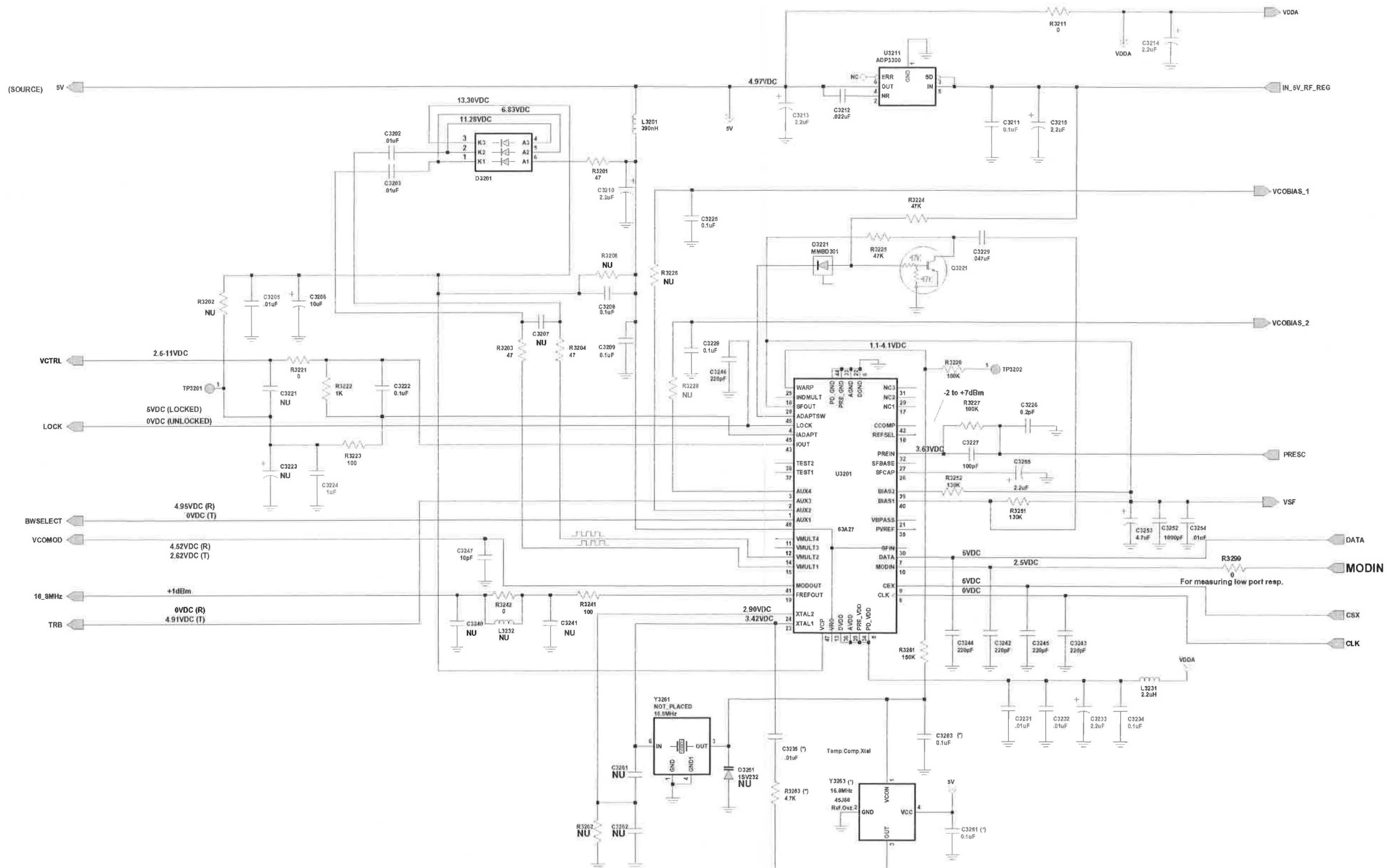

Figure 4-12. 200 MHz Fractional-N Synthesizer Schematic Diagram

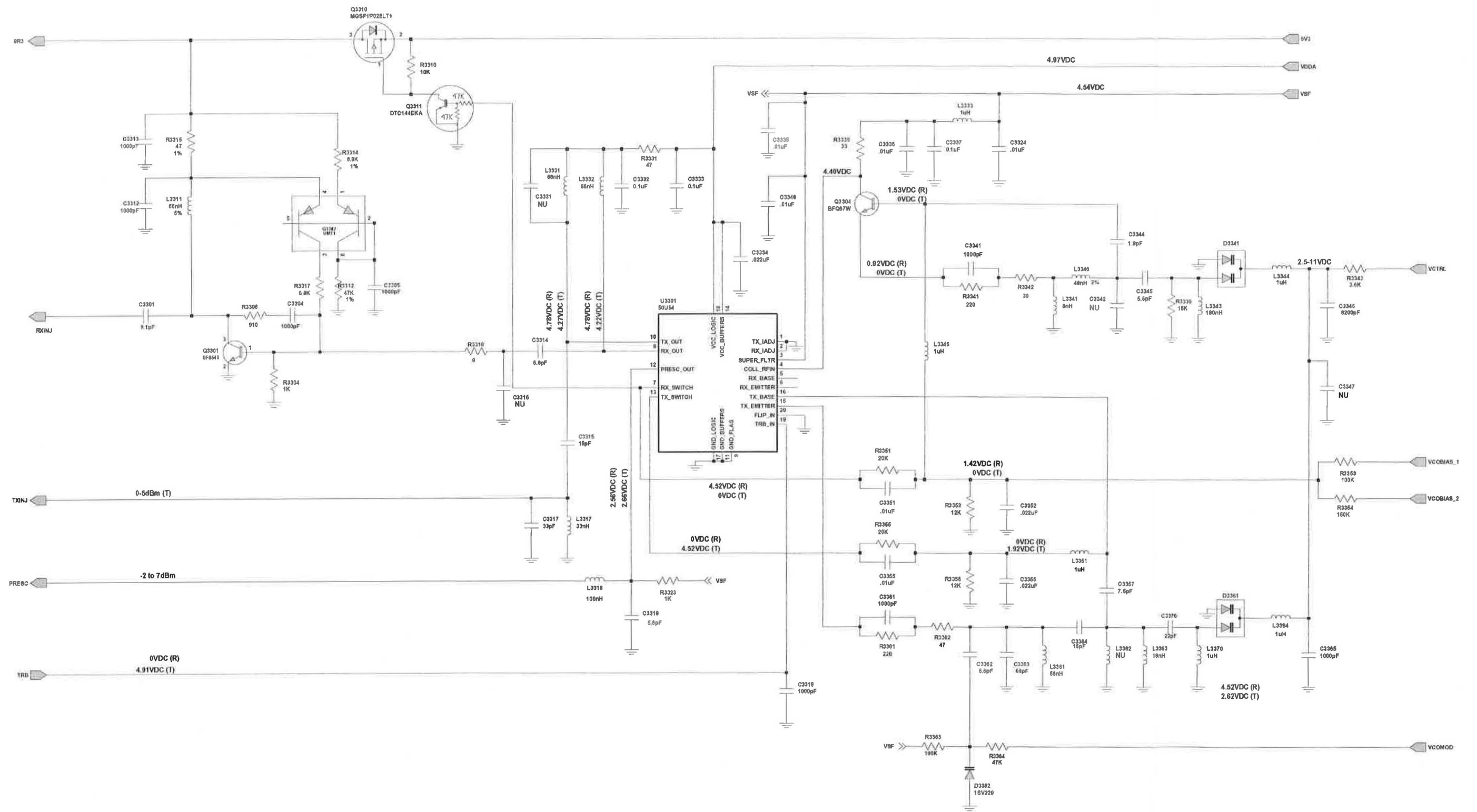

Figure 4-13. 200 MHz Voltage Controlled Oscillator Schematic Diagram

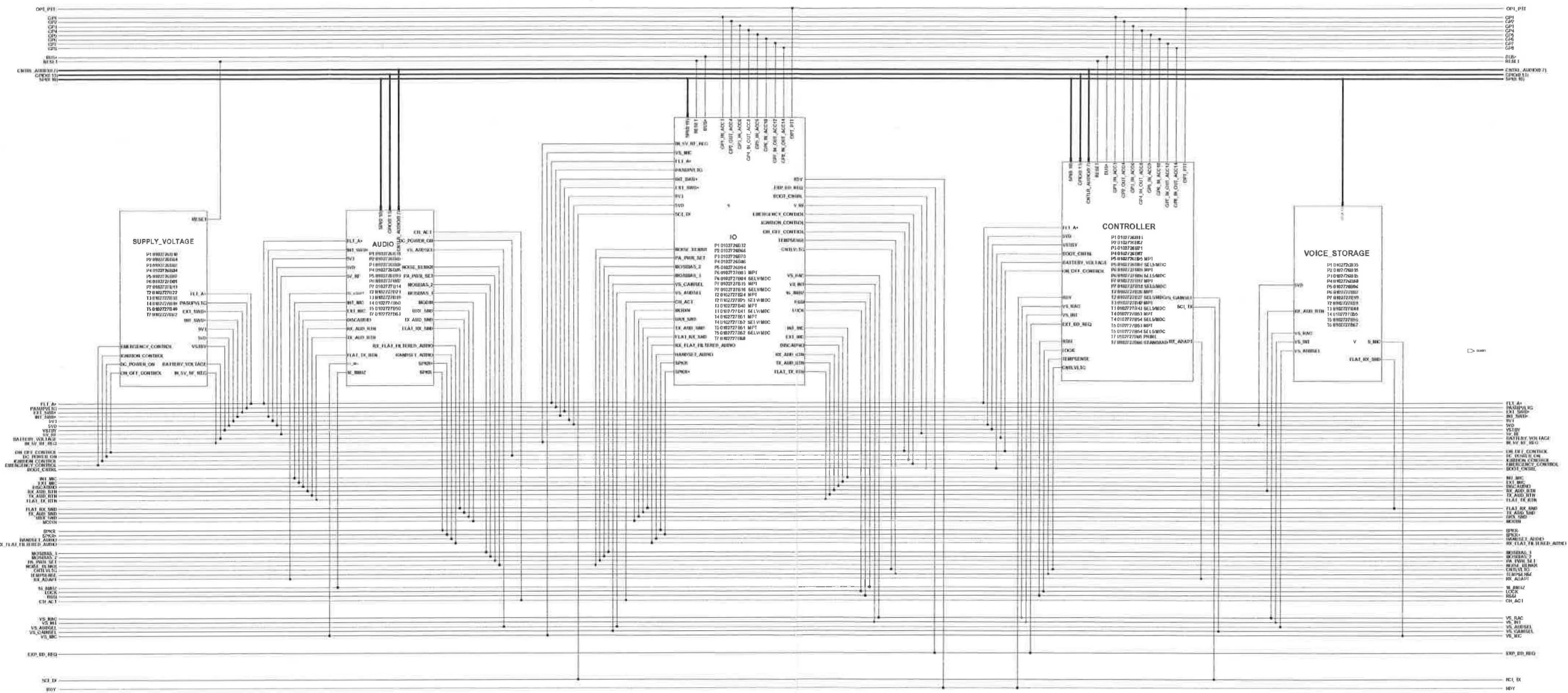

Figure 4-14. 200 MHz Overall Controller Schematic Diagram

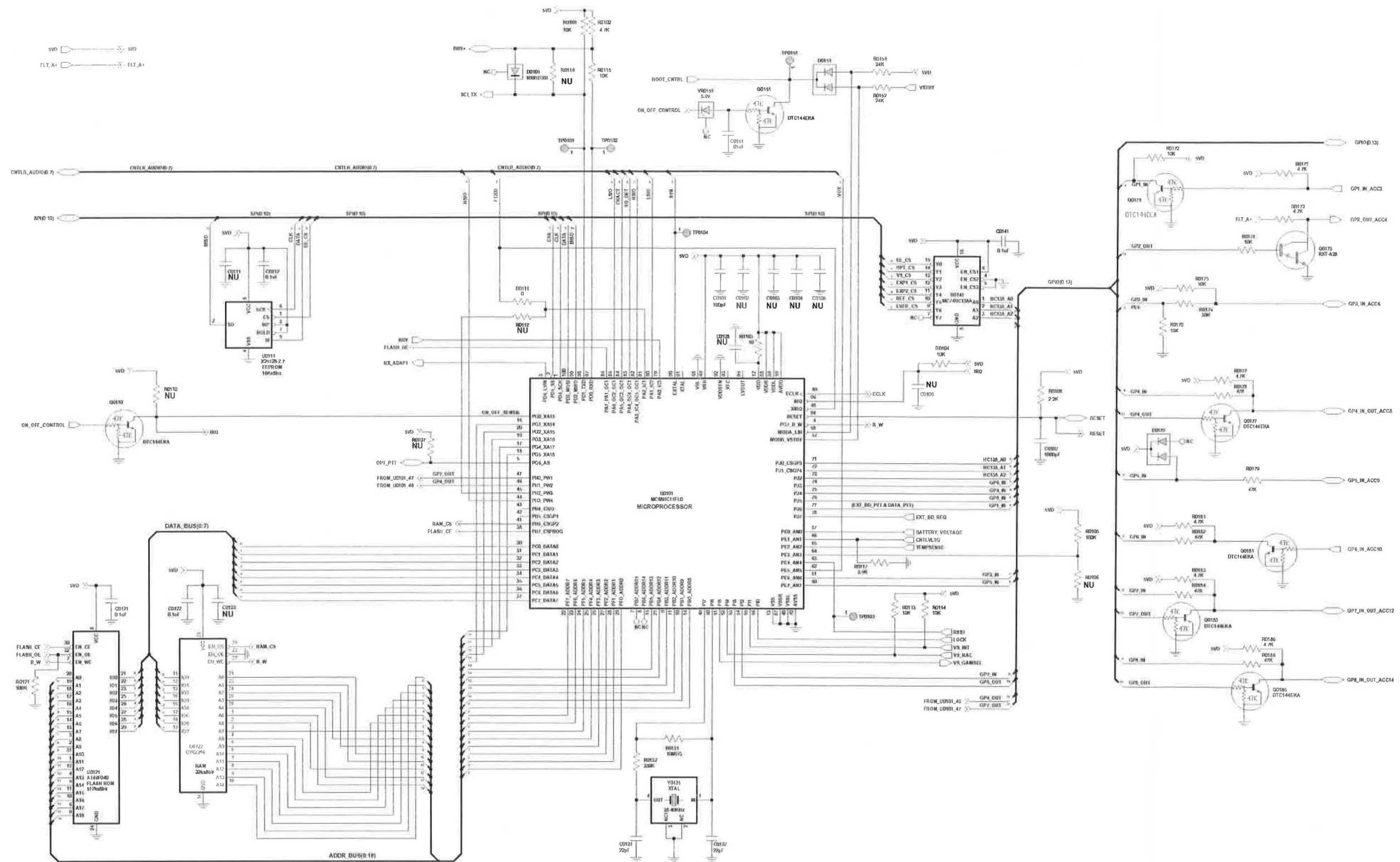

Figure 4-15. 200 MHz Microprocessor Schematic Diagram

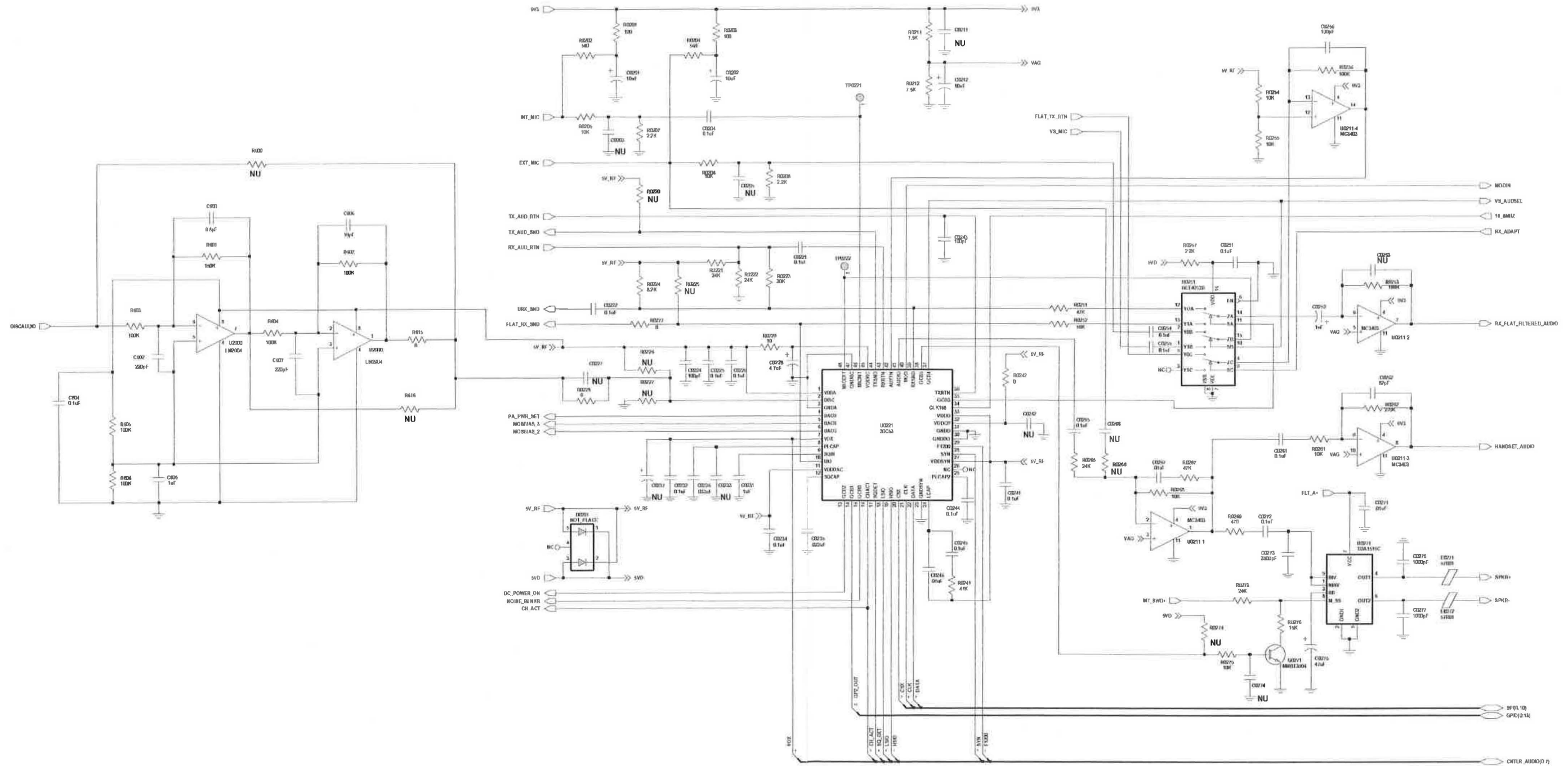

Figure 4-16. 200 MHz Audio Schematic Diagram

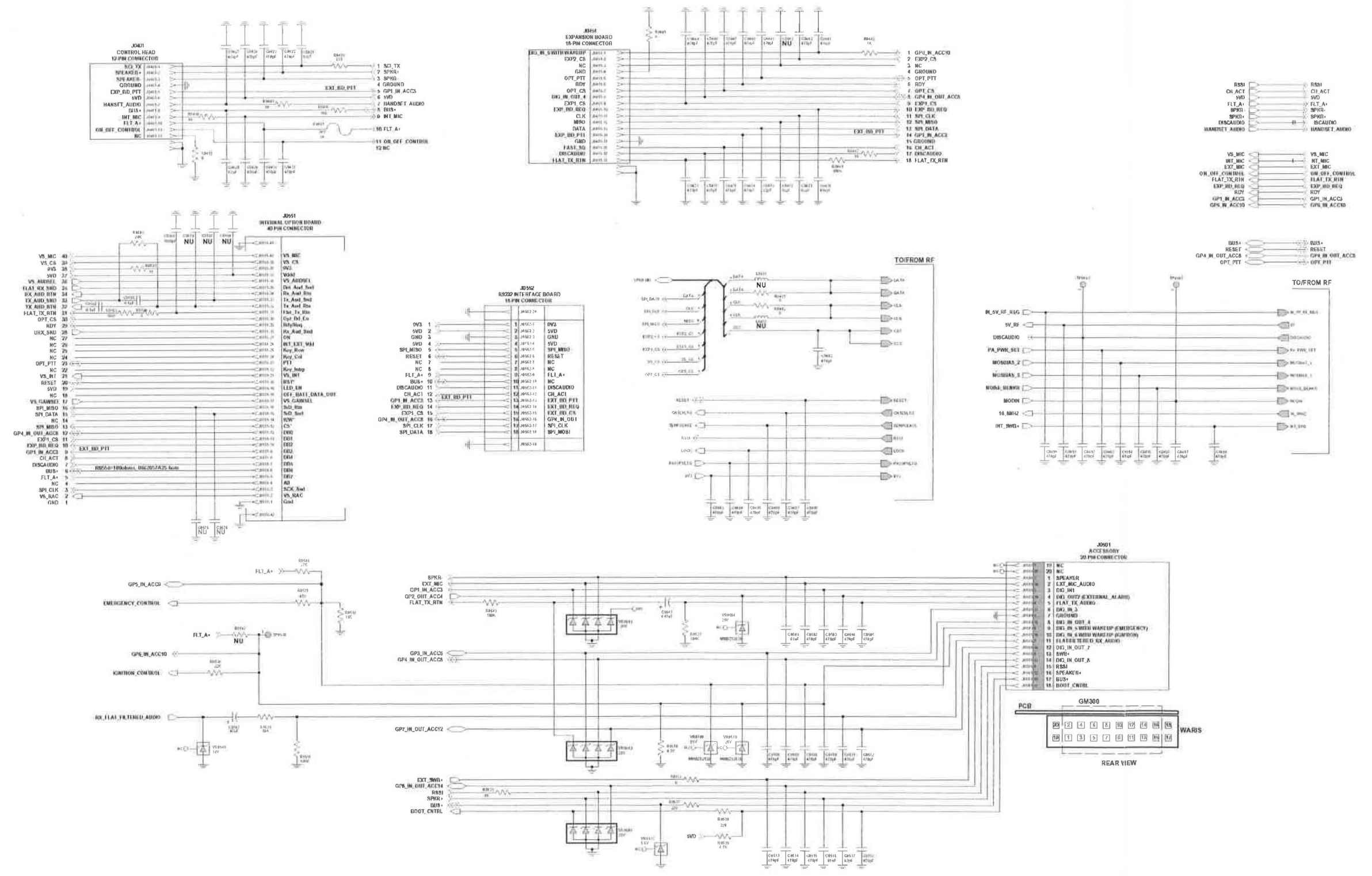

Figure 4-17. 200 MHz Interface and Connectors Schematic Diagram

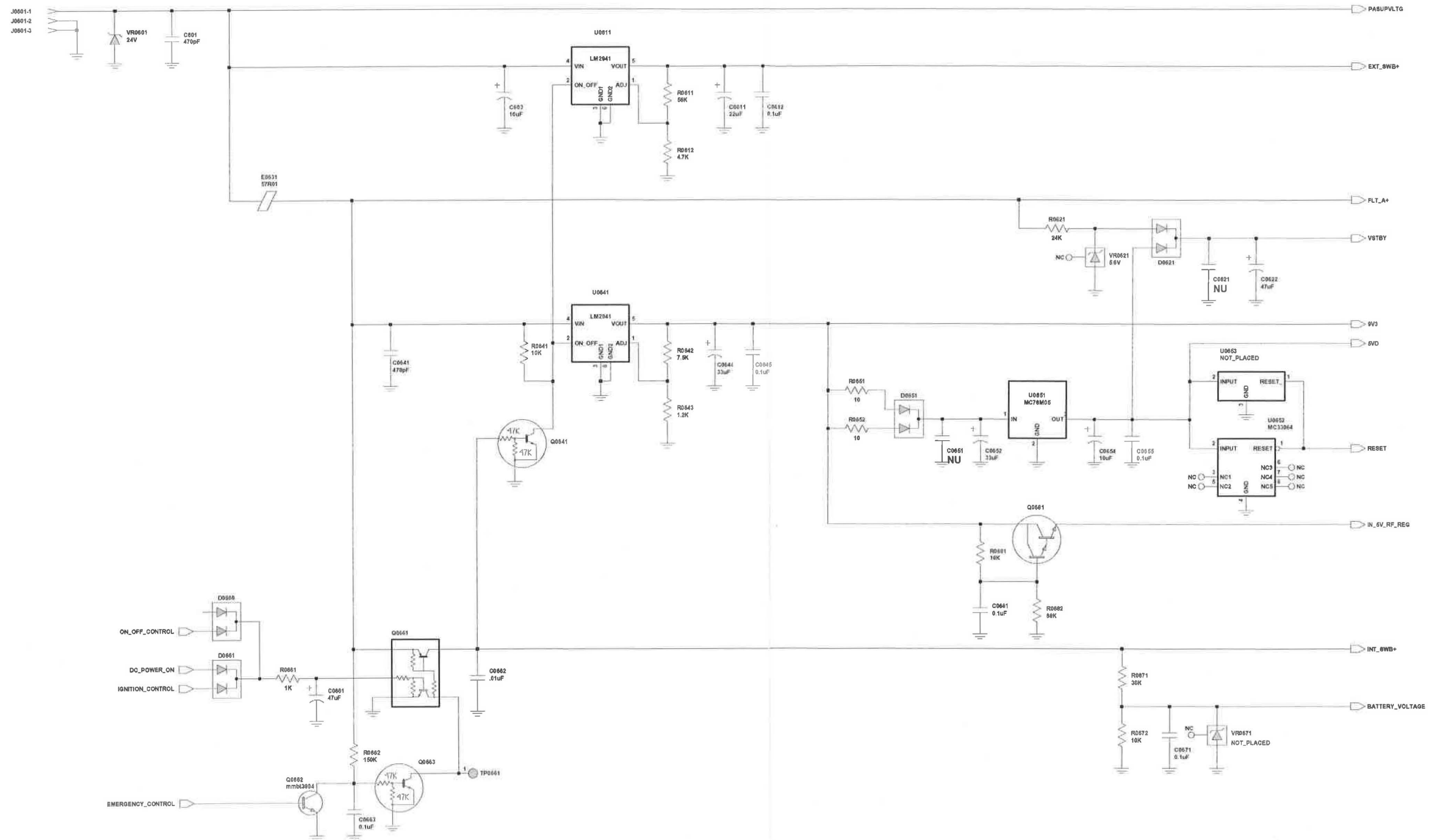

Figure 4-18. 200 MHz Power Supply Schematic Diagram



## 200 MHz Radio Parts List

| Circuit Ref | Motorola Part No. | Description          |
|-------------|-------------------|----------------------|
| C0101       | 2113740F51        | 100 pF               |
| C0102       |                   | not used             |
| C0103       |                   | not used             |
| C0104       |                   | not used             |
| C0105       |                   | not used             |
| C0106       |                   | not used             |
| C0107       | 2113741F25        | 1000 pF              |
| C0108       |                   | not used             |
| C0111       |                   | not used             |
| C0112       | 2113743E20        | 0.1 uF ±10%; 16 V    |
| C0121       | 2113743E20        | 0.1 uF ±10%; 16 V    |
| C0122       | 2113743E20        | 0.1 uF ±10%; 16 V    |
| C0123       |                   | not used             |
| C0131       | 2113740F35        | 22 pF                |
| C0132       | 2113740F35        | 22 pF                |
| C0141       | 2113743E20        | 0.1 uF ±10%; 16 V    |
| C0151       | 2113741F49        | .01 uF ±5%; 50 V     |
| C0201       | 2311049A57        | 10 uF ±10%; 16 V     |
| C0202       | 2311049A57        | 10 uF ±10%; 16 V     |
| C0203       |                   | not used             |
| C0204       | 2113743E20        | 0.1 uF ±10%; 16 V    |
| C0205       |                   | not used             |
| C0211       |                   | not used             |
| C0212       | 2311049A57        | 10 uF ±10%; 16 V     |
| C0221       | 2113743E20        | 0.1 uF ±10%; 16 V    |
| C0222       | 2113743E20        | 0.1 uF ±10%; 16 V    |
| C0224       | 2113740F51        | 100 pF               |
| C0225       | 2113743E20        | 0.1 uF ±10%; 16 V    |
| C0226       | 2113743E20        | 0.1 uF ±10%; 16 V    |
| C0227       |                   | not used             |
| C0228       | 2311049A56        | 4.7 uF ±20%; 10 V    |
| C0231       | 2113743B29        | 1 uF ±10%; 16 V      |
| C0232       | 2113743E20        | 0.1 uF ±10%; 16 V    |
| C0233       |                   | not used             |
| C0234       | 2113743E20        | 0.1 uF ±10%; 16 V    |
| C0235       | 2113743E07        | .022 uF ±10%; 16 V   |
| C0236       | 2113743E10        | .033 uF ±10%; 16 V   |
| C0237       |                   | not used             |
| C0241       | 2113743E20        | 0.1 uF ±10%; 16 V    |
| C0242       |                   | not used             |
| C0243       | 2113740F51        | 100 pF               |
| C0244       | 2113743E20        | 0.1 uF ±10%; 16 V    |
| C0245       | 2113743E20        | 0.1 uF ±10%; 16 V    |
| C0246       | 2113741F49        | .01 uF ±5%; 50 V     |
| C0251       | 2113743E20        | 0.1 uF ±10%; 16 V    |
| C0252       | 2311049A07        | 1 uF ±10%; 16 V+C217 |
| C0253       |                   | not used             |
| C0254       | 2113743E20        | 0.1 uF ±10%; 16 V    |
| C0255       | 2113743E20        | 0.1 uF ±10%; 16 V    |
| C0256       | 2113740F51        | 100 pF               |

| Circuit Ref | Motorola Part No. | Description       |
|-------------|-------------------|-------------------|
| C0261       | 2113743E20        | 0.1 uF ±10%; 16 V |
| C0262       | 2113740F49        | 82 pF             |
| C0265       | 2113743E20        | 0.1 uF ±10%; 16 V |
| C0266       |                   | not used          |
| C0267       | 2113741F49        | .01 uF ±5%; 50 V  |
| C0271       | 2113741F49        | .01 uF ±5%; 50 V  |
| C0272       | 2113743E20        | 0.1 uF ±10%; 16 V |
| C0273       | 2113741F37        | 3300 pF           |
| C0274       |                   | not used          |
| C0275       | 2311049A99        | 47 uF ±20%; 10 V  |
| C0276       | 2113741F25        | 1000 pF           |
| C0277       | 2113741F25        | 1000 pF           |
| C0421       | 2113743N48        | 82 pF             |
| C0422       | 2113741F17        | 470 pF            |
| C0423       | 2113741F17        | 470 pF            |
| C0426       | 2113743L09        | 470 pF            |
| C0427       | 2113743L09        | 470 pF            |
| C0428       | 2113743N48        | 82 pF             |
| C0429       | 2113743L09        | 470 pF            |
| C0430       | 2113741F17        | 470 pF            |
| C0431       | 2113741F17        | 470 pF            |
| C0441       | 2113743L09        | 470 pF            |
| C0442       | 2113743L09        | 470 pF            |
| C0443       |                   | not used          |
| C0445       | 2113743L09        | 470 pF            |
| C0446       | 2113743L09        | 470 pF            |
| C0447       | 2113743L09        | 470 pF            |
| C0448       | 2113743L09        | 470 pF            |
| C0449       | 2113743L09        | 470 pF            |
| C0470       | 2113743L09        | 470 pF            |
| C0471       | 2113743N48        | 82 pF             |
| C0472       | 2113743N48        | 82 pF             |
| C0473       | 2113743N48        | 82 pF             |
| C0474       | 2113743L09        | 470 pF            |
| C0476       | 2113743L09        | 470 pF            |
| C0477       | 2113743L09        | 470 pF            |
| C0478       | 2113743L09        | 470 pF            |
| C0482       | 2113743L09        | 470 pF            |
| C0483       | 2113743L09        | 470 pF            |
| C0484       | 2113741F17        | 470 pF            |
| C0485       | 2113743L09        | 470 pF            |
| C0486       | 2113743L09        | 470 pF            |
| C0487       | 2113743L09        | 470 pF            |
| C0488       | 2113743L09        | 470 pF            |
| C0490       | 2113743L09        | 470 pF            |
| C0491       | 2113743L09        | 470 pF            |
| C0492       | 2113743L09        | 470 pF            |
| C0493       | 2113743L09        | 470 pF            |
| C0494       | 2113743L09        | 470 pF            |
| C0495       | 2113743L09        | 470 pF            |
| C0496       | 2113743L09        | 470 pF            |

| Circuit Ref | Motorola Part No. | Description           |
|-------------|-------------------|-----------------------|
| C0497       | 2113743L09        | 470 pF                |
| C0499       | 2113743L09        | 470 pF                |
| C0501       | 2113741F49        | .01 uF ±5%; 50 V      |
| C0502       | 2113741F17        | 470 pF                |
| C0503       | 2113741F17        | 470 pF                |
| C0504       | 2113741F17        | 470 pF                |
| C0505       | 2113741F17        | 470 pF                |
| C0506       | 2113741F17        | 470 pF                |
| C0508       | 2113741F17        | 470 pF                |
| C0509       | 2113741F17        | 470 pF                |
| C0510       | 2113741F17        | 470 pF                |
| C0511       | 2113741F17        | 470 pF                |
| C0512       | 2113741F17        | 470 pF                |
| C0513       | 2113741F17        | 470 pF                |
| C0514       | 2113741F17        | 470 pF                |
| C0515       | 2113741F17        | 470 pF                |
| C0516       | 2113741F49        | .01 uF ±5%; 50 V      |
| C0517       | 2113743N48        | 82 pF                 |
| C0518       | 2113741F17        | 470 pF                |
| C0541       | 2311049A05        | 0.47 uF               |
| C0542       | 2311049A99        | 47 uF ±20%; 10 V      |
| C0554       |                   | not used              |
| C0558       |                   | not used              |
| C0559       |                   | not used              |
| C0560       | 2113743L17        | 1000 pF               |
| C0575       |                   | not used              |
| C0576       |                   | not used              |
| C0591       | 2113743E20        | 0.1 uF ±10%; 16 V     |
| C0592       | 2113743E20        | 0.1 uF ±10%; 16 V     |
| C0600       | 2113743N22        | 6.8 pF                |
| C0601       | 2113741F17        | 470 pF                |
| C0602       | 2113743L01        | 220 pF                |
| C0603       | 2380090M24        | 10 uF ±20%; 50 V      |
| C0604       | 2113743M24        | 0.1 uF +80/-20%; 16 V |
| C0605       | 2113743F16        | 1 uF +80/-20%; 16 V   |
| C0606       | 2113743N31        | 16 pF                 |
| C0607       | 2113743L01        | 220 pF                |
| C0611       | 2311049C06        | 22 uF ±20%; 35 V      |
| C0612       | 2113743E20        | 0.1 uF ±10%; 16 V     |
| C0621       |                   | not used              |
| C0622       | 2311049A99        | 47 uF ±20%; 10 V      |
| C0641       | 2113741F17        | 470 pF                |
| C0644       | 2311049A97        | 33 uF ±20%; 16 V      |
| C0645       | 2113743E20        | 0.1 uF ±10%; 16 V     |
| C0651       |                   | not used              |
| C0652       | 2311049A97        | 33 uF ±20%; 16 V      |
| C0654       | 2311049A57        | 10 uF ±10%; 16 V      |
| C0655       | 2113743E20        | 0.1 uF ±10%; 16 V     |
| C0661       | 2311049C05        | 47 uF ±10%; 16 V      |
| C0662       | 2113741F49        | .01 uF ±5%; 50 V      |
| C0663       | 2113743E20        | 0.1 uF ±10%; 16 V     |

| Circuit Ref | Motorola Part No. | Description           |
|-------------|-------------------|-----------------------|
| C0671       | 2113743E20        | 0.1 uF ±10%; 16 V     |
| C0681       | 2113743E20        | 0.1 uF ±10%; 16 V     |
| C3040       | 2109445U40        | 20 pF                 |
| C3041       | 2109445U36        | 13 pF                 |
| C3042       | 2109445U45        | 33 pF                 |
| C3043       | 2109445U28        | 4 pF                  |
| C3044       | 2109445U16        | 3.6 pF                |
| C3045       | 2109445U44        | 30 pF                 |
| C3046       | 2109445U27        | 10 pF                 |
| C3047       | 2109445U22        | 6.2 pF                |
| C3051       | 2113743L17        | 1000 pF               |
| C3052       | 2109445U36        | 13 pF                 |
| C3053       | 2109445U35        | 12 pF                 |
| C3054       | 2109445U51        | 56 pF                 |
| C3055       | 2109445U33        | 9 pF                  |
| C3056       | 2109445U27        | 10 pF                 |
| C3057       | 2109445U51        | 56 pF                 |
| C3059       | 2109445U41        | 22 pF                 |
| C3061       | 2113743N48        | 82 pF                 |
| C3070       | 2113743L17        | 1000 pF               |
| C3071       | 2113743L17        | 1000 pF               |
| C3072       | 2113743L17        | 1000 pF               |
| C3073       | 2109445U23        | 6.8 pF                |
| C3074       | 2109445U23        | 6.8 pF                |
| C3075       | 2109445U37        | 15 pF                 |
| C3076       | 2109445U45        | 33 pF                 |
| C3081       | 2109445U37        | 15 pF                 |
| C3090       | 2113743L17        | 1000 pF               |
| C3095       | 2113743L17        | 1000 pF               |
| C3100       | 2113743M24        | 0.1 uF +80/-20%; 16 V |
| C3101       |                   | not used              |
| C3102       | 2113743M24        | 0.1 uF +80/-20%; 16 V |
| C3103       | 2113743E20        | 0.1 uF ±10%; 16 V     |
| C3104       | 2113743M24        | 0.1 uF +80/-20%; 16 V |
| C3105       | 2113743M24        | 0.1 uF +80/-20%; 16 V |
| C3106       | 2113743M24        | 0.1 uF +80/-20%; 16 V |
| C3107       | 2311049A57        | 10 uF ±10%; 16 V      |
| C3108       | 2113743N53        | 130 pF                |
| C3109       | 2113743N38        | 33 pF                 |
| C3110       |                   | not used              |
| C3111       | 2113740L29        | 30 pF                 |
| C3112       |                   | not used              |
| C3113       | 2113743M24        | 0.1 uF +80/-20%; 16 V |
| C3114       | 2113743M24        | 0.1 uF +80/-20%; 16 V |
| C3115       | 2113743M24        | 0.1 uF +80/-20%; 16 V |
| C3116       | 2113743R33        | 4700 pF               |
| C3117       | 2113743M24        | 0.1 uF +80/-20%; 16 V |
| C3120       | 2113743M24        | 0.1 uF +80/-20%; 16 V |
| C3121       | 2113743M24        | 0.1 uF +80/-20%; 16 V |
| C3122       | 2113743N16        | 3.9 pF                |
| C3124       | 2113743M24        | 0.1 uF +80/-20%; 16 V |

| Circuit Ref | Motorola Part No. | Description             |
|-------------|-------------------|-------------------------|
| C3125       | 2113743N12        | 2.7 pF                  |
| C3126       | 2113743N03        | 1 pF                    |
| C3130       | 2113743N28        | 12 pF                   |
| C3181       | 2113743N34        | 22 pF                   |
| C3202       | 2113741F49        | .01 uF ±5%; 50 V        |
| C3203       | 2113741F49        | .01 uF ±5%; 50 V        |
| C3205       | 2113741F49        | .01 uF ±5%; 50 V        |
| C3206       | 2311049A57        | 10 uF ±10%; 16 V        |
| C3207       |                   | not used                |
| C3208       | 2113743E20        | 0.1 uF ±10%; 16 V       |
| C3209       | 2113743E20        | 0.1 uF ±10%; 16 V       |
| C3210       | 2311049A40        | 2.2 uF ±10%; 10 V       |
| C3211       | 2113743E20        | 0.1 uF ±10%; 16 V       |
| C3212       | 2113743E07        | .022 uF ±10%; 16 V      |
| C3213       | 2311049A40        | 2.2 uF ±10%; 10 V       |
| C3214       | 2311049A09        | 2.2 uF ±10%; 10 V       |
| C3215       | 2311049A09        | 2.2 uF ±10%; 10 V       |
| C3221       |                   | not used                |
| C3222       | 2113743E20        | 0.1 uF ±10%; 16 V       |
| C3223       |                   | not used                |
| C3224       | 0882422W23        | 1 uF                    |
| C3225       | 2113743E20        | 0.1 uF ±10%; 16 V       |
| C3226       | 2113740F25        | 8.2 pF                  |
| C3227       | 2113740F51        | 100 pF                  |
| C3228       | 2113743E20        | 0.1 uF ±10%; 16 V       |
| C3229       | 2113743E12        | .047 uF ±10%; 16 V+C289 |
| C3231       | 2113741F49        | .01 uF ±5%; 50 V        |
| C3232       | 2113741F49        | .01 uF ±5%; 50 V        |
| C3233       | 2311049A40        | 2.2 uF ±10%; 10 V       |
| C3234       | 2113743E20        | 0.1 uF ±10%; 16 V       |
| C3235       | 2113741F49        | .01 uF ±5%; 50 V        |
| C3240       |                   | not used                |
| C3241       |                   | not used                |
| C3242       | 2113740F59        | 220 pF                  |
| C3243       | 2113740F59        | 220 pF                  |
| C3244       | 2113740F59        | 220 pF                  |
| C3245       | 2113740F59        | 220 pF                  |
| C3246       | 2113740F59        | 220 pF                  |
| C3247       | 2113740F27        | 10 pF                   |
| C3251       | 2113743E20        | 0.1 uF ±10%; 16 V       |
| C3252       | 2113741F25        | 1000 pF                 |
| C3253       | 2311049A56        | 4.7 uF ±20%; 10 V       |
| C3254       | 2113741F49        | .01 uF ±5%; 50 V        |
| C3255       | 2311049A40        | 2.2 uF ±10%; 10 V       |
| C3261       |                   | not used                |
| C3262       |                   | not used                |
| C3263       | 2113743E20        | 0.1 uF ±10%; 16 V       |
| C3301       | 2113743N25        | 9.1 pF                  |
| C3304       | 2113743L17        | 1000 pF                 |
| C3305       | 2113743L17        | 1000 pF                 |
| C3312       | 2113743L17        | 1000 pF                 |

| Circuit Ref | Motorola Part No. | Description        |
|-------------|-------------------|--------------------|
| C3313       | 2113743L17        | 1000 pF            |
| C3314       | 2113740F23        | 6.8 pF             |
| C3315       | 2113740F31        | 15 pF              |
| C3316       |                   | not used           |
| C3317       | 2113740F39        | 33 pF              |
| C3318       | 2113740F21        | 5.6 pF             |
| C3319       | 2113741F25        | 1000 pF            |
| C3324       | 2113741F49        | .01 uF ±5%; 50 V   |
| C3331       |                   | not used           |
| C3332       | 2113743E20        | 0.1 uF ±10%; 16 V  |
| C3333       | 2113743E20        | 0.1 uF ±10%; 16 V  |
| C3334       | 2113743E07        | .022 uF ±10%; 16 V |
| C3335       | 2113741F49        | .01 uF ±5%; 50 V   |
| C3336       | 2113741F49        | .01 uF ±5%; 50 V   |
| C3337       | 2113743E20        | 0.1 uF ±10%; 16 V  |
| C3341       | 2113741F25        | 1000 pF            |
| C3342       |                   | not used           |
| C3344       | 2113740F09        | 1.8 pF             |
| C3345       | 2113740F21        | 5.6 pF             |
| C3346       | 2113741F47        | 8200 pF            |
| C3347       |                   | not used           |
| C3348       | 2113741F49        | .01 uF ±5%; 50 V   |
| C3351       | 2113741F49        | .01 uF ±5%; 50 V   |
| C3352       | 2113743E07        | .022 uF ±10%; 16 V |
| C3355       | 2113741F49        | .01 uF ±5%; 50 V   |
| C3356       | 2113743E07        | .022 uF ±10%; 16 V |
| C3357       | 2113740F24        | 7.5 pF             |
| C3361       | 2113741F25        | 1000 pF            |
| C3362       | 2113740F21        | 5.6 pF             |
| C3363       | 2113740F47        | 68 pF              |
| C3364       | 2113740F31        | 15 pF              |
| C3365       | 2113741F25        | 1000 pF            |
| C3370       | 2113743N34        | 22 pF              |
| C3400       | 2113740F63        | 330 pF             |
| C3401       | 2113740F63        | 330 pF             |
| C3402       | 2113743E07        | .022 uF ±10%; 16 V |
| C3403       | 2113740F39        | 33 pF              |
| C3404       | 2113740F39        | 33 pF              |
| C3405       | 2113740F67        | 470 pF             |
| C3406       | 2113740F67        | 470 pF             |
| C3410       | 2113743E07        | .022 uF ±10%; 16 V |
| C3411       | 2113743E07        | .022 uF ±10%; 16 V |
| C3412       | 2113740F63        | 330 pF             |
| C3413       |                   | not used           |
| C3414       | 2113740F63        | 330 pF             |
| C3415       | 2113743E07        | .022 uF ±10%; 16 V |
| C3416       | 2113740F63        | 330 pF             |
| C3417       | 2113741F33        | 2200 pF            |
| C3418       | 2113740F41        | 39 pF              |
| C3419       | 2113740F63        | 330 pF             |
| C3420       | 2113740F63        | 330 pF             |

| Circuit Ref | Motorola Part No. | Description           |
|-------------|-------------------|-----------------------|
| C3421       | 2113741A57        | .033 uF ±5%; 50 V     |
| C3422       | 2113740A67        | 330 pF                |
| C3423       | 2311049A08        | 1 uF                  |
| C3424       | 2113740F67        | 470 pF                |
| C3425       | 2113743E07        | .022 uF ±10%; 16 V    |
| C3426       | 2113740F63        | 330 pF                |
| C3427       | 2113741F33        | 2200 pF               |
| C3428       | 2113741F33        | 2200 pF               |
| C3431       | 2111078B22        | 22 pF                 |
| C3432       |                   | not used              |
| C3433       | 2111078B29        | 33 pF                 |
| C3434       | 2113741A45        | .01 uF ±5%; 50 V      |
| C3435       | 2113740A67        | 330 pF                |
| C3436       | 2311049A45        | 10 uF ±10%; 35 V+C361 |
| C3437       | 2113741A57        | .033 uF ±5%; 50 V     |
| C3438       | 2111078B59        | 470 pF                |
| C3439       | 2111078B59        | 470 pF                |
| C3440       | 2113741F25        | 1000 pF               |
| C3441       | 2111078B42        | 100 pF                |
| C3442       |                   | not used              |
| C3443       |                   | not used              |
| C3444       |                   | not used              |
| C3445       | 2111078B20        | 18 pF                 |
| C3446       | 2111078B34        | 47 pF                 |
| C3447       | 2111078B13        | 10 pF                 |
| C3448       |                   | not used              |
| C3449       |                   | not used              |
| C3450       | 2113740F67        | 470 pF                |
| C3451       | 2113741F25        | 1000 pF               |
| C3452       | 2113740F29        | 12 pF                 |
| C3453       | 2113740F67        | 470 pF                |
| C3454       |                   | not used              |
| C3471       | 2113743E07        | .022 uF ±10%; 16 V    |
| C3472       | 2111078B53        | 270 pF                |
| C3473       | 2111078B53        | 270 pF                |
| C3474       | 2113740F59        | 220 pF                |
| C3475       | 2113740F23        | 6.8 pF                |
| C3491       | 2111078B13        | 10 pF                 |
| C3492       | 2111078B35        | 51 pF                 |
| C3493       | 2180060M05        | 3 pF                  |
| C3494       | 2111078B13        | 10 pF                 |
| C3495       | 2111078B01        | 3.3 pF                |
| C3496       | 2111078B24        | 25 pF                 |
| C3497       |                   | not used              |
| C3498       | 2111078B13        | 10 pF                 |
| C3499       | 2111078B13        | 10 pF                 |
| C3501       | 2113741F33        | 2200 pF               |
| C3502       | 2113741F33        | 2200 pF               |
| C3503       | 2113740F67        | 470 pF                |
| C3504       | 2113741F49        | .01 uF ±5%; 50 V      |
| C3505       | 2311049A07        | 1 uF                  |

| Circuit Ref | Motorola Part No. | Description                     |
|-------------|-------------------|---------------------------------|
| C3506       | 2113741F33        | 2200 pF                         |
| C3507       | 2113740F51        | 100 pF                          |
| C3508       | 2113740F67        | 470 pF                          |
| C3509       |                   | not used                        |
| C3510       | 2113740F67        | 470 pF                          |
| CR3001      | 4802245J92        | Quad Crossover Mixer Diode      |
| CR3003      | 4880154K03        | Dual Schottky Diode MMBD353     |
| CR3200      | 4880154K03        | Dual Schottky Diode MMBD353     |
| D0101       | 4813825A05        | Schottky Diode MMBD301          |
| D0151       | 4813833C02        | Dual Diode Common Cathode       |
| D0179       | 4813833C02        | Dual Diode Common Cathode       |
| D0201       |                   | not used                        |
| D0621       | 4813833C02        | Dual Diode Common Cathode       |
| D0651       | 4813833C02        | Dual Diode Common Cathode       |
| D0660       | 4813833C02        | Dual Diode Common Cathode       |
| D0661       | 4813833C02        | Dual Diode Common Cathode       |
| D3090       | 4880142L01        | MMBV3401LT                      |
| D3201       | 4802233J09        | IMN10                           |
| D3221       | 4813825A05        | Schottky Diode MMBD301          |
| D3261       |                   | not used                        |
| D3341       | 4805649Q13        | Varactor 1SV228                 |
| D3361       | 4805649Q13        | Varactor 1SV228                 |
| D3362       | 4862824C01        | Varactor 1SV228                 |
| D3401       |                   | not used                        |
| D3451       | 4813825A05        | Schottky Diode MMBD301          |
| D3471       | 4802482J02        | PIN Diode MA4P959               |
| D3472       | 4802482J02        | PIN Diode MA4P959               |
| E0271       | 2484657R01        | Ferrite Bead                    |
| E0272       | 2484657R01        | Ferrite Bead                    |
| E0631       | 2484657R01        | Ferrite Bead                    |
| F0401       | 6580542Z01        | Fuse 3A                         |
| FL3101      | 9180022M10        | 44.85 MHz 4-pole Crystal Filter |
| FL3106      | 9180469V03        | 6-pole 455 kHz Ceramic Filter   |
| J0401       | 0902636Y02        | Connector, Flex, 12-pin         |
| J0451       | 0902636Y01        | Connector, Flex, Side Entry     |
| J0501       | 0986105B01        | Connector, 20-pin, Accessory    |
| J0551       | 0905505Y04        | Connector, 40-pin, Option Board |
| J0552       | 0905505Y03        | Connector, 18-pin, RS232        |
| J0601       | 0986165B01        | DC Power Connector              |
| J3401       | 0986166B02        | Mini-UHF RF Connector           |
| L0481       |                   | not used                        |
| L0482       |                   | not used                        |
| L3020       | 2413923C09        | 68 nH                           |
| L3021       | 2413923C09        | 68 nH                           |
| L3022       | 2413923C09        | 68 nH                           |
| L3023       | 2409415M39        | 68 nH                           |
| L3024       | 2413923C09        | 68 nH                           |

| Circuit Ref | Motorola Part No. | Description            | Circuit Ref | Motorola Part No. | Description            | Circuit Ref | Motorola Part No. | Description | Circuit Ref | Motorola Part No. | Description |
|-------------|-------------------|------------------------|-------------|-------------------|------------------------|-------------|-------------------|-------------|-------------|-------------------|-------------|
| L3025       | 2462587N55        | 150 nH                 | Q0181       | 4880048M01        | Digital NPN DTC144EKA  | R0173       | 0662057A65        | 4.7 K       | R0275       | 0662057A73        | 10 K        |
| L3027       | 2413923C09        | 68 nH                  | Q0183       | 4880048M01        | Digital NPN DTC144EKA  | R0174       | 0662057A73        | 10 K        | R0276       | 0662057A77        | 15 K        |
| L3028       | 2413923C09        | 68 nH                  | Q0185       | 4880048M01        | Digital NPN DTC144EKA  | R0175       | 0662057A73        | 10 K        | R0277       | 0662057B47        | 0           |
| L3040       | 2413923A25        | 1.2 uH                 | Q0271       | 4880214G02        | MMBT3904 NPN           | R0176       | 0662057A84        | 30 K        | R0401       | 0662057A33        | 220         |
| L3041       | 2413923C09        | 68 nH                  | Q0641       | 4880048M01        | Digital NPN DTC144EKA  | R0177       | 0662057A65        | 4.7 K       | R0407       | 0662057M26        | 10          |
| L3090       | 2462587N69        | 1.2 uH                 | Q0661       | 4805921T02        | Dual NPN/PNP FMC2A     | R0178       | 0662057A89        | 47 K        | R0408       | 0662057A25        | 100         |
| L3100       |                   | not used               | Q0662       | 4813824A10        | MMBT3904 NPN           | R0179       | 0662057A89        | 47 K        | R0409       | 0662057M26        | 10          |
| L3102       | 2462587N69        | 1.2 uH                 | Q0663       | 4880048M01        | Digital NPN DTC144EKA  | R0181       | 0662057A65        | 4.7 K       | R0412       | 0662057B47        | 0           |
| L3181       | 2462587N61        | 470 nH                 | Q0681       | 4880052M01        | RXT-A28 NPN Darlington | R0182       | 0662057A89        | 47 K        | R0441       | 0662057B47        | 0           |
| L3201       | 2462587Q42        | 390 nH                 | Q3002       | 4802245J95        | BFS540 NPN             | R0183       | 0662057A65        | 4.7 K       | R0442       | 0662057A49        | 1 K         |
| L3231       | 2462587Q20        | 2.2 uH                 | Q3003       | 4805723X02        | Dual PNP UMT1          | R0184       | 0662057A89        | 47 K        | R0467       | 0662057M26        | 10          |
| L3232       |                   | not used               | Q3090       | 4809939C05        | Dual NPN/PNP UMC5NTL   | R0185       | 0662057A65        | 4.7 K       | R0468       | 0662057A97        | 100 K       |
| L3311       | 2462587N50        | 56 nH                  | Q3110       | 4802197J95        | PBR941 NPN             | R0186       | 0662057A89        | 47 K        | R0481       | 0662057B47        | 0           |
| L3317       | 2462587V28        | 33 nH                  | Q3111       | 4813824A10        | MMBT3904 NPN           | R0201       | 0662057A25        | 100         | R0482       | 0662057B47        | 0           |
| L3318       | 2462587V34        | 100 nH                 | Q3221       | 4880048M01        | Digital NPN DTC144EKA  | R0202       | 0662057A43        | 560         | R0510       | 0662057A65        | 4.7 K       |
| L3331       | 2462587V32        | 68 nH                  | Q3301       | 4802245J95        | BFS540 NPN             | R0203       | 0662057A25        | 100         | R0511       | 0662057A97        | 100 K       |
| L3332       | 2462587V31        | 56 nH                  | Q3302       | 4805723X02        | Dual PNP UMT1          | R0204       | 0662057A43        | 560         | R0512       | 0662057A77        | 15 K        |
| L3333       | 2462587Q47        | 1 uH                   | Q3304       | 4805218N63        | BFQ67W NPN             | R0205       | 0662057A73        | 10 K        | R0525       | 0662057A97        | 100 K       |
| L3341       | 2484562T13        | 8 nH                   | Q3310       | 4813823A27        | MGSF1P02ELT1           | R0206       | 0662057A73        | 10 K        | R0529       | 0662057A89        | 47 K        |
| L3343       | 2462587N56        | 180 nH                 | Q3311       | 4880048M01        | Digital NPN DTC144EKA  | R0207       | 0662057A57        | 2.2 K       | R0530       | 0662057A81        | 22 K        |
| L3344       | 2462587N68        | 1 uH                   | Q3411       | 4805921T02        | FMC2A                  | R0208       | 0662057A57        | 2.2 K       | R0531       | 0662057A43        | 560         |
| L3345       | 2462587N68        | 1 uH                   | Q3421       | 4886212B01        | MRF1518                | R0211       | 0660076E70        | 7.5 K       | R0533       | 0662057B47        | 0           |
| L3346       | 2484562T19        | 48 nH                  | Q3422       | 4880048M01        | Digital NPN DTC144EKA  | R0212       | 0660076E70        | 7.5 K       | R0535       | 0662057A49        | 1 K         |
| L3351       | 2462587N68        | 1 uH                   | Q3441       | 4886136B01        | 36B01                  | R0220       |                   | not used    | R0537       | 0662057A33        | 220         |
| L3361       | 2462587N50        | 56 nH                  | Q3442       | 4880048M01        | Digital NPN DTC144EKA  | R0221       | 0662057A82        | 24 K        | R0538       | 0662057A33        | 220         |
| L3362       |                   | not used               | Q3471       | 4880048M01        | Digital NPN DTC144EKA  | R0222       | 0662057A82        | 24 K        | R0539       | 0662057A65        | 4.7 K       |
| L3363       | 2462587N44        | 18 nH                  | Q3472       | 4805128M27        | BSR33 PNP              | R0223       | 0662057A84        | 30 K        | R0541       | 0662057A83        | 27 K        |
| L3364       | 2462587N68        | 1 uH                   | R0101       | 0662057A73        | 10 K                   | R0224       | 0662057A71        | 8.2 K       | R0542       |                   | not used    |
| L3370       | 2462587N68        | 1 uH                   | R0102       | 0662057A65        | 4.7 K                  | R0225       |                   | not used    | R0543       | 0662057A97        | 100 K       |
| L3401       | 2479990A01        | 4.22 nH                | R0103       | 0662057A01        | 10                     | R0226       |                   | not used    | R0591       | 0662057A82        | 24 K        |
| L3402       | 2484657R01        | Ferrite Bead           | R0104       | 0662057A73        | 10 K                   | R0227       |                   | not used    | R0592       | 0662057A01        | 10          |
| L3403       | 2462587T13        | 68 nH                  | R0105       | 0662057A97        | 100 K                  | R0228       | 0662057B47        | 0           | R0593       | 0662057A97        | 100 K       |
| L3411       | 2462587T13        | 68 nH                  | R0106       |                   | not used               | R0229       | 0662057A01        | 10          | R0594       | 0611077A01        | 0           |
| L3412       | 2462587N40        | 8.2 nH                 | R0107       |                   | not used               | R0241       | 0662057A89        | 47 K        | R0600       |                   | not used    |
| L3413       |                   | not used               | R0108       | 0662057A57        | 2.2 K                  | R0242       | 0662057B47        | 0           | R0601       | 0662057N27        | 150 K       |
| L3414       | 2479990A02        | 7.66 nH                | R0110       |                   | not used               | R0251       | 0662057A89        | 47 K        | R0602       | 0662057N23        | 100 K       |
| L3421       | 2484657R01        | Ferrite Bead           | R0111       | 0662057B47        | 0                      | R0252       | 0662057A91        | 56 K        | R0603       | 0662057N23        | 100 K       |
| L3422       | 2479990C03        | 13.85 nH               | R0112       |                   | not used               | R0253       | 0662057A97        | 100 K       | R0604       | 0662057N23        | 100 K       |
| L3436       | 2484657R01        | Ferrite Bead           | R0113       | 0662057A73        | 10 K                   | R0254       | 0662057A73        | 10 K        | R0605       | 0662057N23        | 100 K       |
| L3437       | 2460592A01        | 17 nH                  | R0114       | 0662057A73        | 10 K                   | R0255       | 0662057A73        | 10 K        | R0606       | 0662057N23        | 100 K       |
| L3443       | 2460591X02        | 25 nH                  | R0115       | 0662057A73        | 10 K                   | R0256       | 0662057A97        | 100 K       | R0615       | 0662057M01        | 0           |
| L3471       | 2462587N69        | 1.2 uH                 | R0116       |                   | not used               | R0257       | 0662057A57        | 2.2 K       | R0616       |                   | not used    |
| L3472       | 2460592B02        | 37 nH                  | R0117       | 0662057A63        | 3.9 K                  | R0261       | 0662057A73        | 10 K        | R0611       | 0662057A91        | 56 K        |
| L3491       | 2460592B02        | 37 nH                  | R0121       | 0662057A97        | 100 K                  | R0262       | 0662057B08        | 270 K       | R0612       | 0662057A65        | 4.7 K       |
| L3492       | 2460592B02        | 37 nH                  | R0131       | 0662057B46        | 10 C577MEG             | R0265       | 0662057A82        | 24 K        | R0621       | 0662057A82        | 24 K        |
| L3493       | 2460592B02        | 37 nH                  | R0132       | 0662057B10        | 330 K                  | R0266       |                   | not used    | R0641       | 0662057A73        | 10 K        |
| Q0110       | 4880048M01        | Digital NPN DTC144EKA  | R0151       | 0662057A82        | 24 K                   | R0267       | 0662057A89        | 47 K        | R0642       | 0660076E70        | 7.5 K       |
| Q0151       | 4880048M01        | Digital NPN DTC144EKA  | R0152       | 0662057A82        | 24 K                   | R0268       | 0662057A73        | 10 K        | R0643       | 0660076E51        | 1.2 K       |
| Q0171       | 4880048M01        | Digital NPN DTC144EKA  | R0170       | 0662057A73        | 10 K                   | R0269       | 0662057A41        | 470         | R0651       | 0662057A01        | 10          |
| Q0173       | 4880052M01        | RXT-A28 NPN Darlington | R0171       | 0662057A65        | 4.7 K                  | R0273       | 0662057A82        | 24 K        | R0652       | 0662057A01        | 10          |
| Q0177       | 4880048M01        | Digital NPN DTC144EKA  | R0172       | 0662057A73        | 10 K                   | R0274       |                   | not used    | R0661       | 0662057A49        | 1 K         |

| Circuit Ref | Motorola Part No. | Description |
|-------------|-------------------|-------------|
| R0662       | 0662057B02        | 150 K       |
| R0671       | 0662057A84        | 30 K        |
| R0672       | 0662057A73        | 10 K        |
| R0681       | 0662057A79        | 18 K        |
| R0682       | 0662057A93        | 68 K        |
| R3018       | 0662057M66        | 470         |
| R3030       | 0662057U61        | 240         |
| R3031       | 0662057U97        | 6.8 K       |
| R3032       | 0662057M43        | 51          |
| R3033       | 0662057V11        | 22 K        |
| R3034       | 0662057M94        | 6.8 K       |
| R3035       | 0662057M73        | 910         |
| R3036       | 0662057M92        | 5.6 K       |
| R3090       | 0662057M65        | 430         |
| R3099       | 0662057M50        | 100         |
| R3100       | 0662057M86        | 3.3 K       |
| R3101       | 0662057M83        | 2.4 K       |
| R3102       | 0662057M43        | 51          |
| R3103       |                   | not used    |
| R3105       | 0662057B47        | 0           |
| R3106       | 0662057N03        | 15 K        |
| R3108       | 0662057M98        | 10 K        |
| R3109       | 0662057M92        | 5.6 K       |
| R3110       | 0662057M70        | 680         |
| R3111       | 0662057N01        | 12 K        |
| R3115       | 0662057A55        | 1.8 K       |
| R3116       | 0662057A39        | 390         |
| R3120       | 0662057M78        | 1.5 K       |
| R3121       | 0662057M62        | 330         |
| R3122       | 0662057N11        | 33 K        |
| R3123       | 0662057M90        | 4.7 K       |
| R3124       | 0662057N01        | 12 K        |
| R3125       | 0662057M90        | 4.7 K       |
| R3135       | 0662057M76        | 1.2 K       |
| R3201       | 0662057A17        | 47          |
| R3202       |                   | not used    |
| R3203       | 0662057A17        | 47          |
| R3204       | 0662057A17        | 47          |
| R3206       |                   | not used    |
| R3211       | 0662057B47        | 0           |
| R3220       | 0662057A97        | 100 K       |
| R3221       | 0662057B47        | 0           |
| R3222       | 0662057A49        | 1 K         |
| R3223       | 0662057A25        | 100         |
| R3224       | 0662057A89        | 47 K        |
| R3225       | 0662057A89        | 47 K        |
| R3226       |                   | not used    |
| R3227       | 0662057A97        | 100 K       |
| R3228       |                   | not used    |
| R3241       | 0662057A25        | 100         |
| R3242       | 0662057B47        | 0           |

| Circuit Ref | Motorola Part No. | Description |
|-------------|-------------------|-------------|
| R3251       | 0662057B01        | 130 K       |
| R3252       | 0662057B01        | 130 K       |
| R3261       | 0662057B02        | 150 K       |
| R3262       |                   | not used    |
| R3263       | 0662057A65        | 4.7 K       |
| R3299       | 0662057B47        | 0           |
| R3304       | 0662057A49        | 1 K         |
| R3306       | 0662057M73        | 910         |
| R3310       | 0662057A73        | 10 K        |
| R3312       | 0662057V19        | 47 K        |
| R3314       | 0662057U97        | 6.8 K       |
| R3315       | 0662057U43        | 47          |
| R3317       | 0662057M94        | 6.8 K       |
| R3318       | 0662057B47        | 0           |
| R3323       | 0662057A49        | 1 K         |
| R3331       | 0662057A17        | 47          |
| R3335       | 0662057A13        | 33          |
| R3336       | 0662057A77        | 15 K        |
| R3341       | 0662057A33        | 220         |
| R3342       | 0662057A15        | 39          |
| R3343       | 0662057A62        | 3.6 K       |
| R3351       | 0662057A80        | 20 K        |
| R3352       | 0662057A75        | 12 K        |
| R3353       | 0662057A97        | 100 K       |
| R3354       | 0662057B02        | 150 K       |
| R3355       | 0662057A80        | 20 K        |
| R3356       | 0662057A75        | 12 K        |
| R3361       | 0662057A33        | 220         |
| R3362       | 0662057A17        | 47          |
| R3363       | 0662057B04        | 180 K       |
| R3364       | 0662057A89        | 47 K        |
| R3400       | 0662057A41        | 470         |
| R3401       | 0662057A36        | 300         |
| R3402       | 0662057A05        | 15          |
| R3403       | 0662057A36        | 300         |
| R3404       | 0662057A73        | 10 K        |
| R3405       | 0662057A25        | 100         |
| R3406       | 0662057A97        | 100 K       |
| R3411       |                   | not used    |
| R3412       | 0662057A67        | 5.6 K       |
| R3413       | 0662057A61        | 3.3 K       |
| R3414       | 0683962T51        | 120         |
| R3415       | 0662057A14        | 36          |
| R3416       | 0662057A14        | 36          |
| R3417       | 0662057A73        | 10 K        |
| R3418       | 0662057A81        | 22 K        |
| R3421       | 0662057A87        | 39 K        |
| R3422       | 0662057A57        | 2.2 K       |
| R3423       | 0662057A87        | 39 K        |
| R3424       | 0662057C13        | 2.7         |
| R3425       | 0662057C13        | 2.7         |

| Circuit Ref | Motorola Part No. | Description                         |
|-------------|-------------------|-------------------------------------|
| R3426       | 0662057C13        | 2.7                                 |
| R3427       | 0662057C13        | 2.7                                 |
| R3428       | 0662057A58        | 2.4 K                               |
| R3429       |                   | not used                            |
| R3431       | 0680194M18        | 51                                  |
| R3432       | 0680194M18        | 51                                  |
| R3433       | 0662057C13        | 2.7                                 |
| R3434       | 0662057C13        | 2.7                                 |
| R3435       | 0662057C13        | 2.7                                 |
| R3440       |                   | not used                            |
| R3441       | 0662057A87        | 39 K                                |
| R3442       | 0662057A57        | 2.2 K                               |
| R3443       | 0662057A87        | 39 K                                |
| R3444       | 0662057C19        | 4.7                                 |
| R3445       | 0662057A58        | 2.4 K                               |
| R3446       | 0662057B47        | 0                                   |
| R3450       | 0662057A41        | 470                                 |
| R3452       | 0662057A75        | 12 K                                |
| R3454       | 0662057A84        | 30 K                                |
| R3455       | 0662057A97        | 100 K                               |
| R3457       | 0683962T51        | 120                                 |
| R3471       | 0662057A41        | 470                                 |
| R3473       | 0680194M18        | 51                                  |
| R3474       | 0680194M18        | 51                                  |
| R3475       | 0662057A73        | 10 K                                |
| R3491       | 0662057A73        | 10 K                                |
| R3501       | 0662057A69        | 6.8 K                               |
| R3502       | 0662057A87        | 39 K                                |
| R3504       | 0662057A73        | 10 K                                |
| R3505       | 0662057B09        | 300 K                               |
| R3506       |                   | not used                            |
| R3507       | 0662057A80        | 20 K                                |
| R3508       | 0662057A97        | 100 K                               |
| R3509       | 0662057A49        | 1 K                                 |
| SH3103      | 2686081B03        | Shield, IF Top                      |
| SH3301      | 2602641Y02        | Shield, VCO Top                     |
| T3001       | 2580541Z02        | Mixer Balun                         |
| T3002       | 2580541Z02        | Mixer Balun                         |
| U0101       | 5102226J56        | Microcontroller MC68HC11FLO         |
| U0111       | 5102463J64        | EEPROM X25128-2.7                   |
| U0121       | 5186137B01        | 512K x 8bit Flash ROM               |
| U0122       | 5185748L01        | 32K x 8bit SRAM                     |
| U0141       | 5113805A30        | Demux MC74HC138A                    |
| U0211       | 5183222M49        | Quad Opamp MC3403                   |
| U0221       | 5185130C53        | ASFIC Audio Filter IC               |
| U0251       | 5184704M60        | Mux/Demux HEF4053B                  |
| U0271       | 5102463J95        | Audio Power Amp TDA1519C            |
| U0611       | 5183308X01        | Adjustable Voltage Regulator LM2941 |

| Circuit Ref | Motorola Part No. | Description                         |
|-------------|-------------------|-------------------------------------|
| U0641       | 5183308X01        | Adjustable Voltage Regulator LM2941 |
| U0651       | 5113816A07        | 5V Regulator MC78M05                |
| U0652       | 5113815A02        | Under Voltage Sensor MC33064        |
| U0653       |                   | not used                            |
| U2000       | 5180932W01        | Dual Opamp LM2904                   |
| U3101       | 5186144B01        | SA616 IFIC                          |
| U3201       | 5185963A27        | Low Voltage FracN                   |
| U3211       | 5105739X05        | 5V Regulator MC78M05                |
| U3301       | 5105750U54        | VCO Buffer IC                       |
| U3401       | 5185130C65        | LDMOS Power Amplifier               |
| U3402       | 5180932W01        | Dual Opamp LM2904                   |
| U3501       | 5185765B26        | Power Control IC                    |
| U3502       | 5185963A15        | Temperature Sensor LM50             |
| VR0151      | 4813830A15        | 5.6V Zener MMBZ5232B                |
| VR0501      | 4805656W09        | Quad 20V Zener MMQA20VT1            |
| VR0503      | 4805656W09        | Quad 20V Zener MMQA20VT1            |
| VR0504      | 4813830A36        | 25V Zener MMBZ5253B                 |
| VR0505      | 4805656W09        | Quad 20V Zener MMQA20VT1            |
| VR0509      | 4813830A36        | 25V Zener MMBZ5253B                 |
| VR0510      | 4813830A36        | 25V Zener MMBZ5253B                 |
| VR0537      | 4813830A15        | 5.6V Zener MMBZ5232B                |
| VR0541      | 4813830A27        | 14V Zener MMBZ5244B                 |
| VR0601      | 4813832C77        | Transient Suppressor MR2835S        |
| VR0621      | 4813830A15        | 5.6V Zener 5.6V Zener MMBZ5232B     |
| VR0671      |                   | not used                            |
| VR3471      | 4813830A15        | 5.6V Zener MMBZ5232B                |
| Y0131       | 4880113R19        | Ceramic Resonator 38.4 kHz          |
| Y3100       | 4880606B09        | 44.395 MHz 3rd Overtone Crystal     |
| Y3102       | 9186145B02        | 455 kHz Discriminator               |
| Y3104       | 9180468V04        | 4-pole 455 kHz Ceramic Filter       |
| Y3261       |                   | not used                            |
| Y3263       | 4802245J68        | 16.8 MHz Crystal Oscillator         |

\* Motorola Depot Servicing only

Reference designators with an asterisk indicate components which are not field replaceable because they need to be calibrated with specialized factory equipment after installation. Radios in which these parts have been replaced in the field will be off-frequency at temperature extremes.

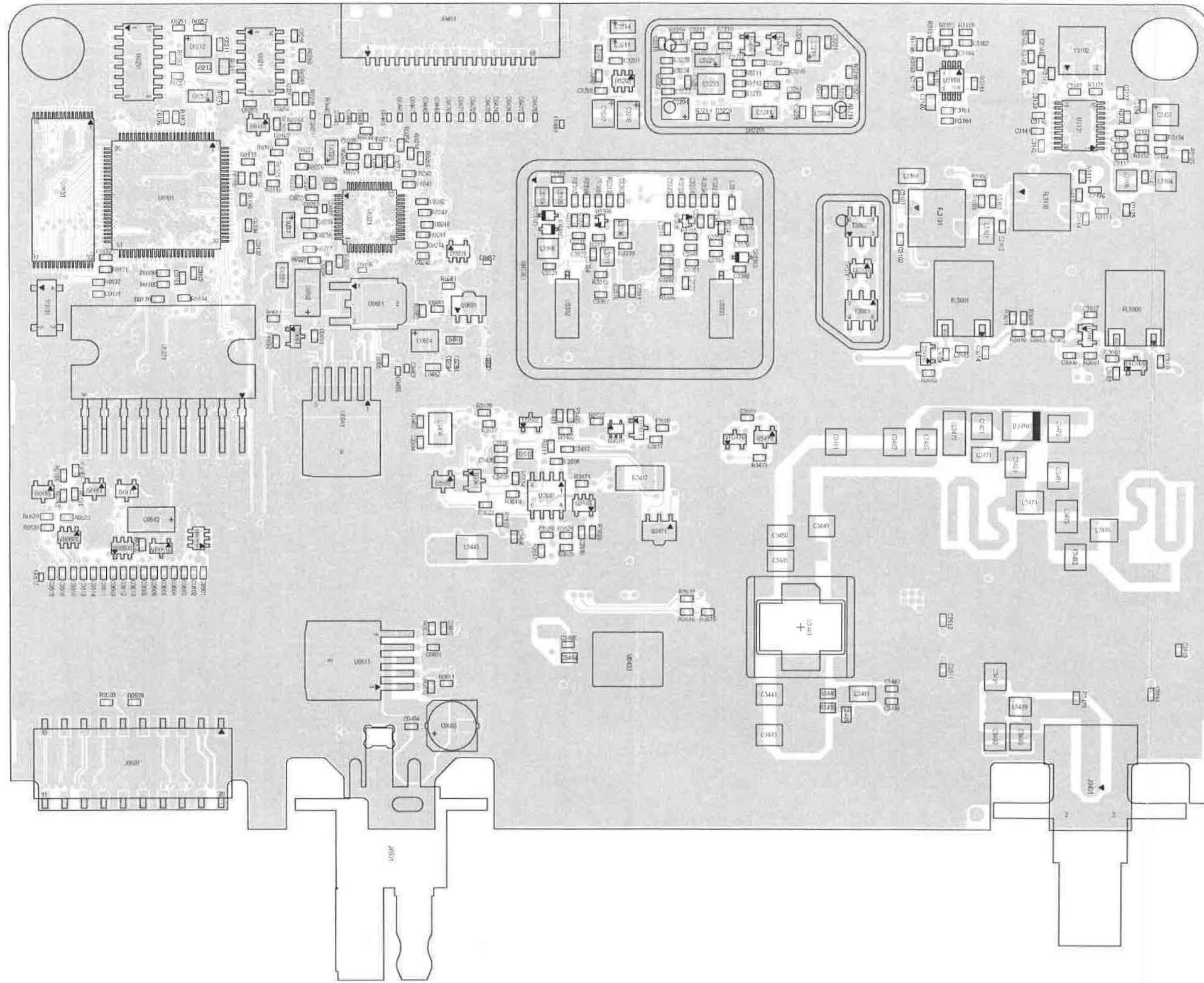

Figure 4-19. 700 MHz Main Board Top Side PCB

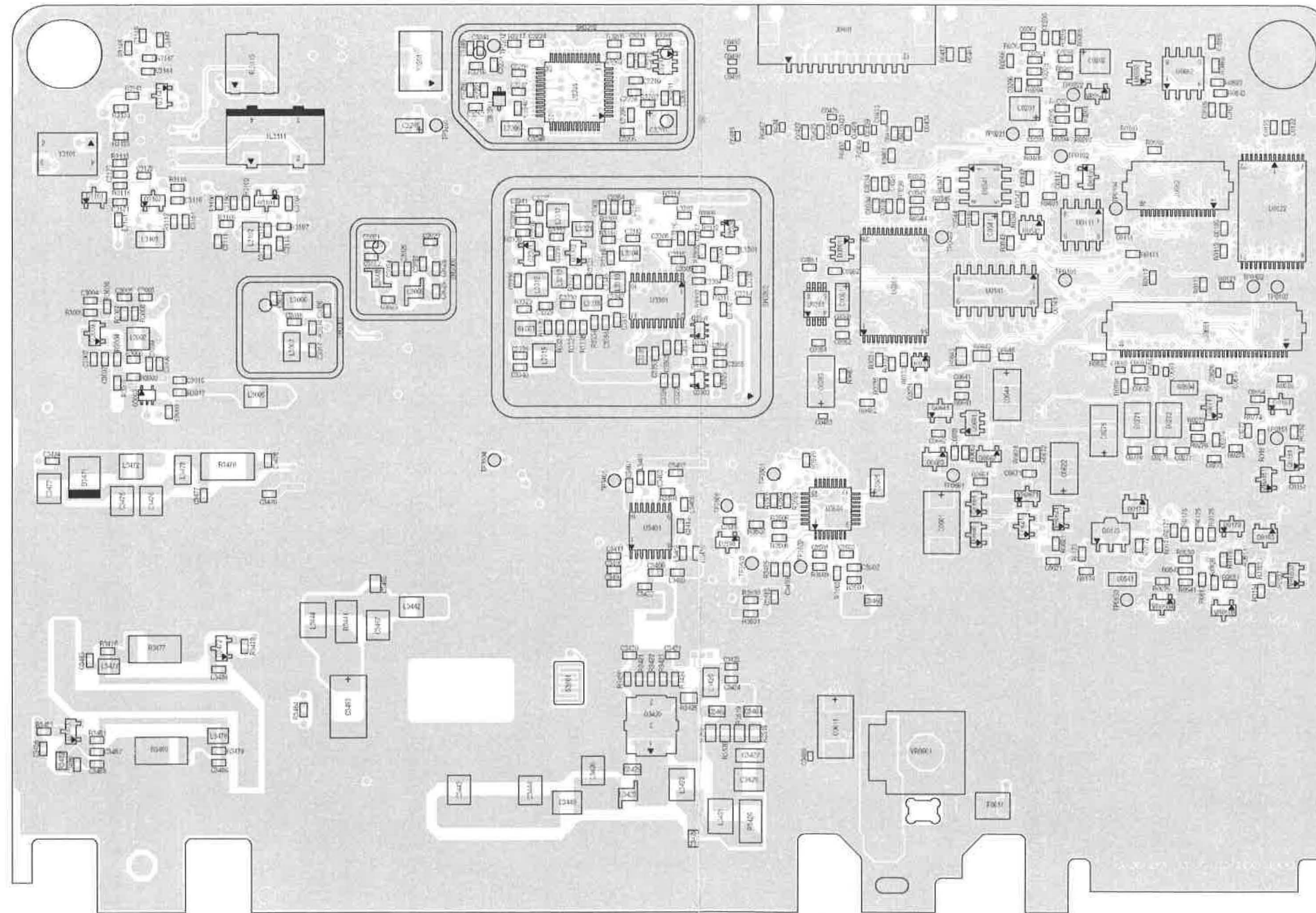

Figure 4-20. 700 MHz Main Board Bottom Side PCB

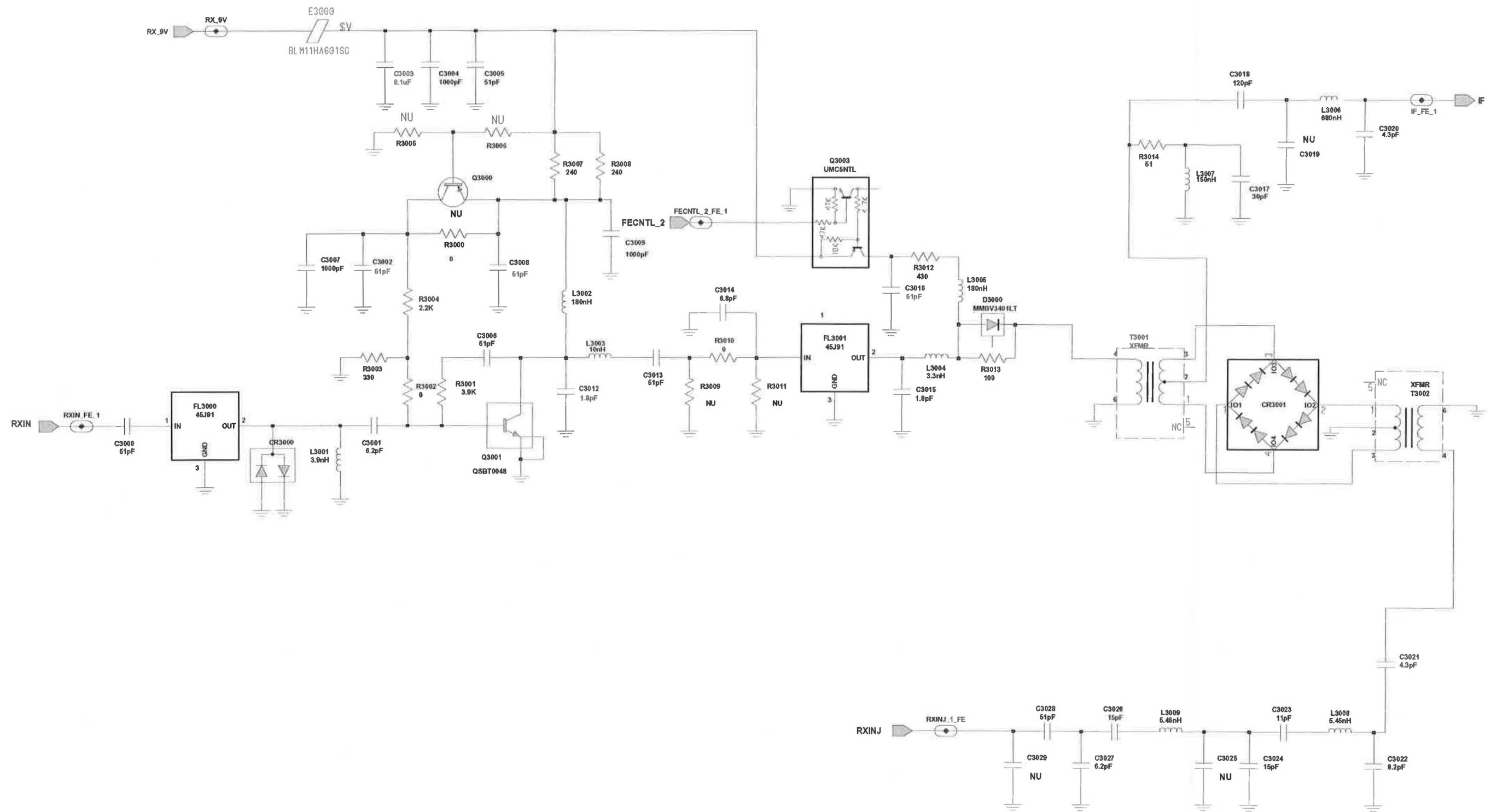

Figure 4-21. 700 MHz Receiver Front End Schematic Diagram

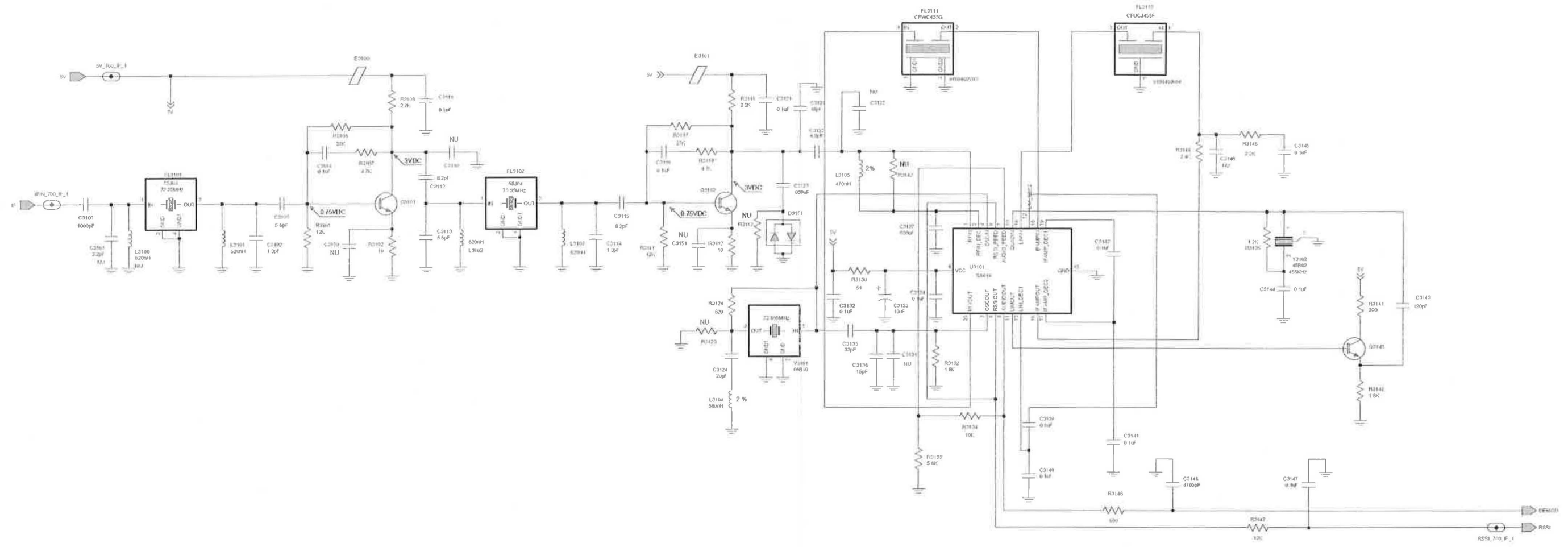

Figure 4-22. 700 MHz Receiver IF Schematic Diagram



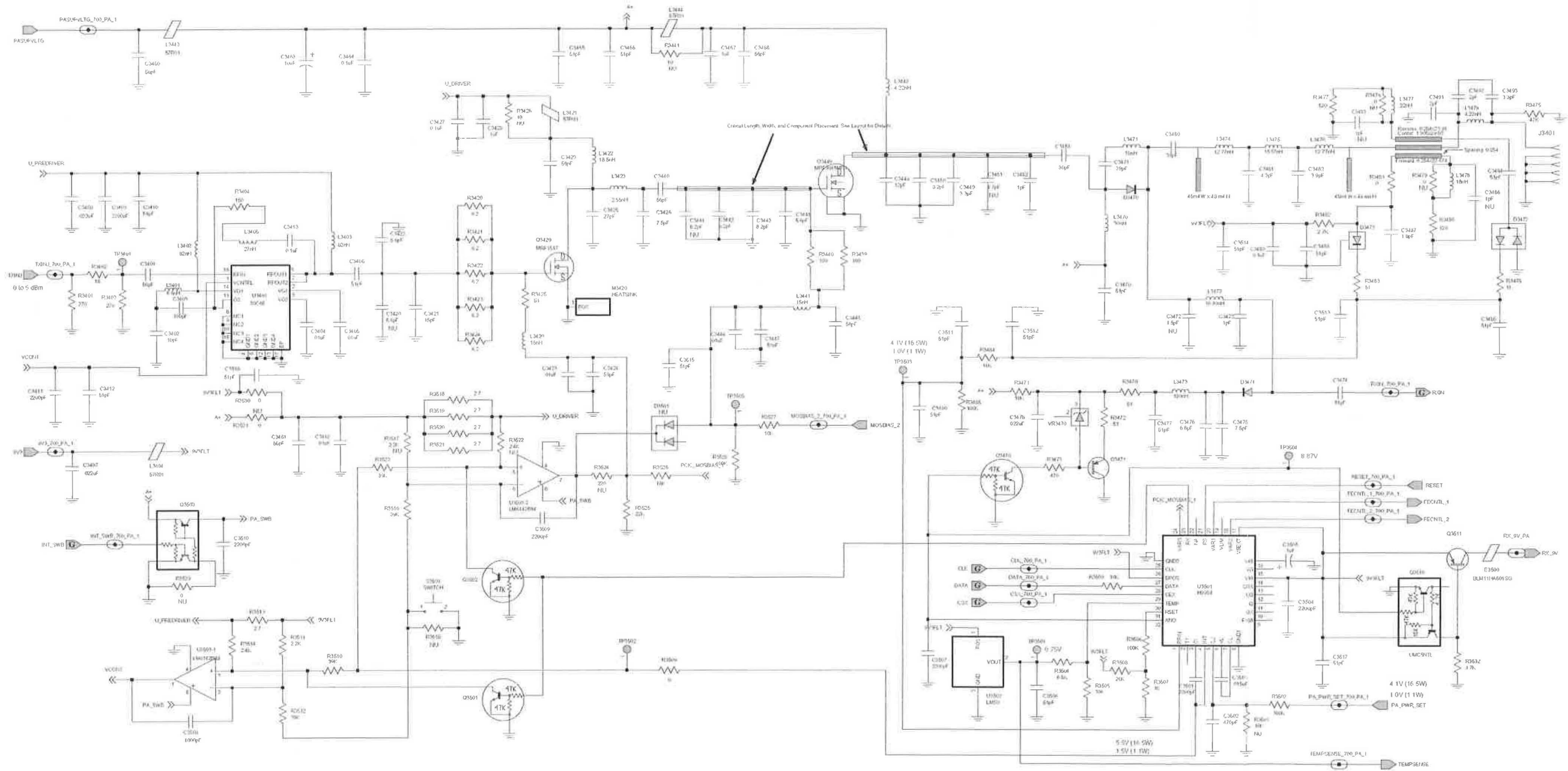

Figure 4-23. 700 MHz Transmitter Power Amplifier Schematic Diagram

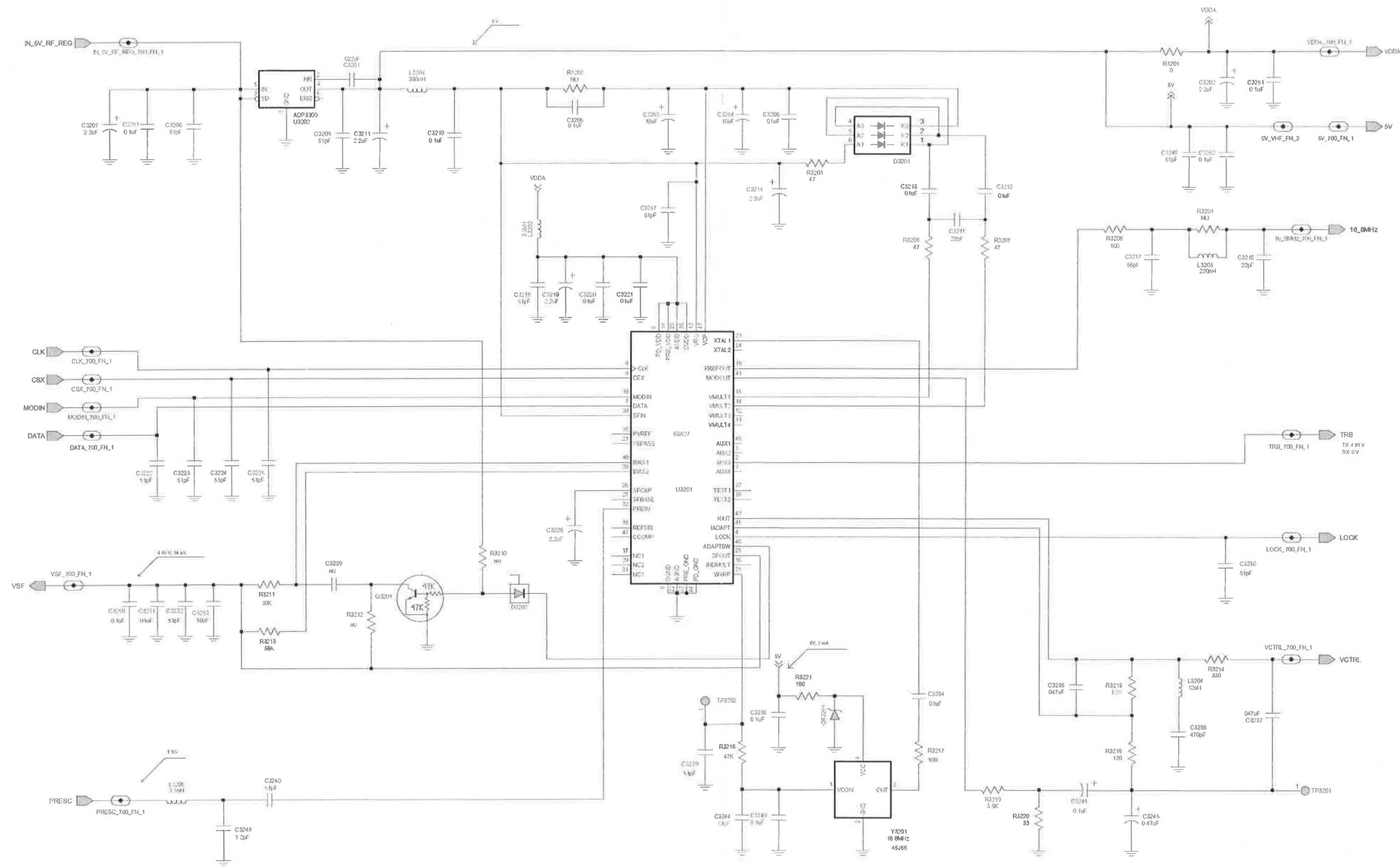

Figure 4-24. 700 MHz Fractional-N Synthesizer Schematic Diagram

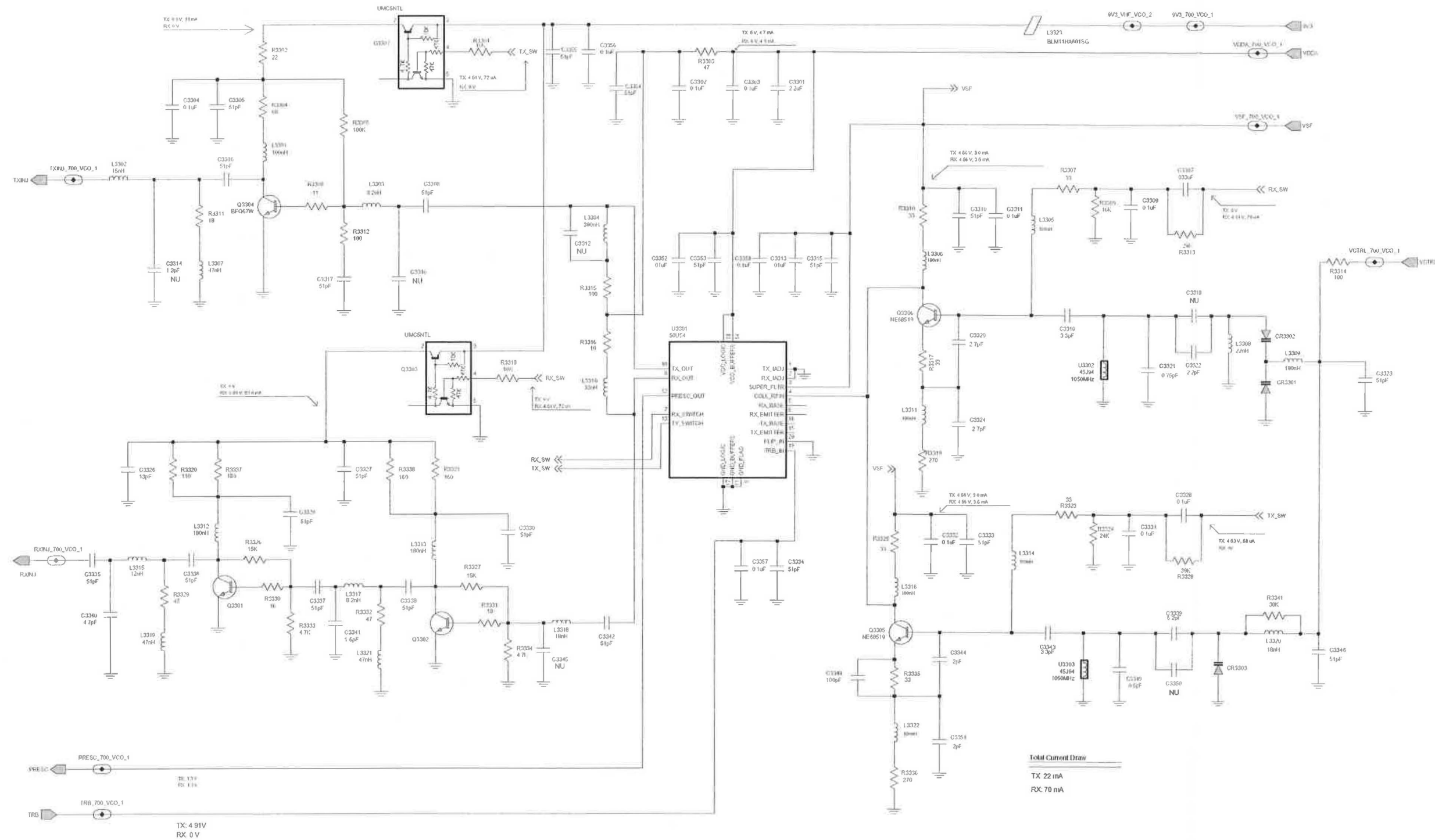

Figure 4-25. 700 MHz Voltage Controlled Oscillator Schematic Diagram

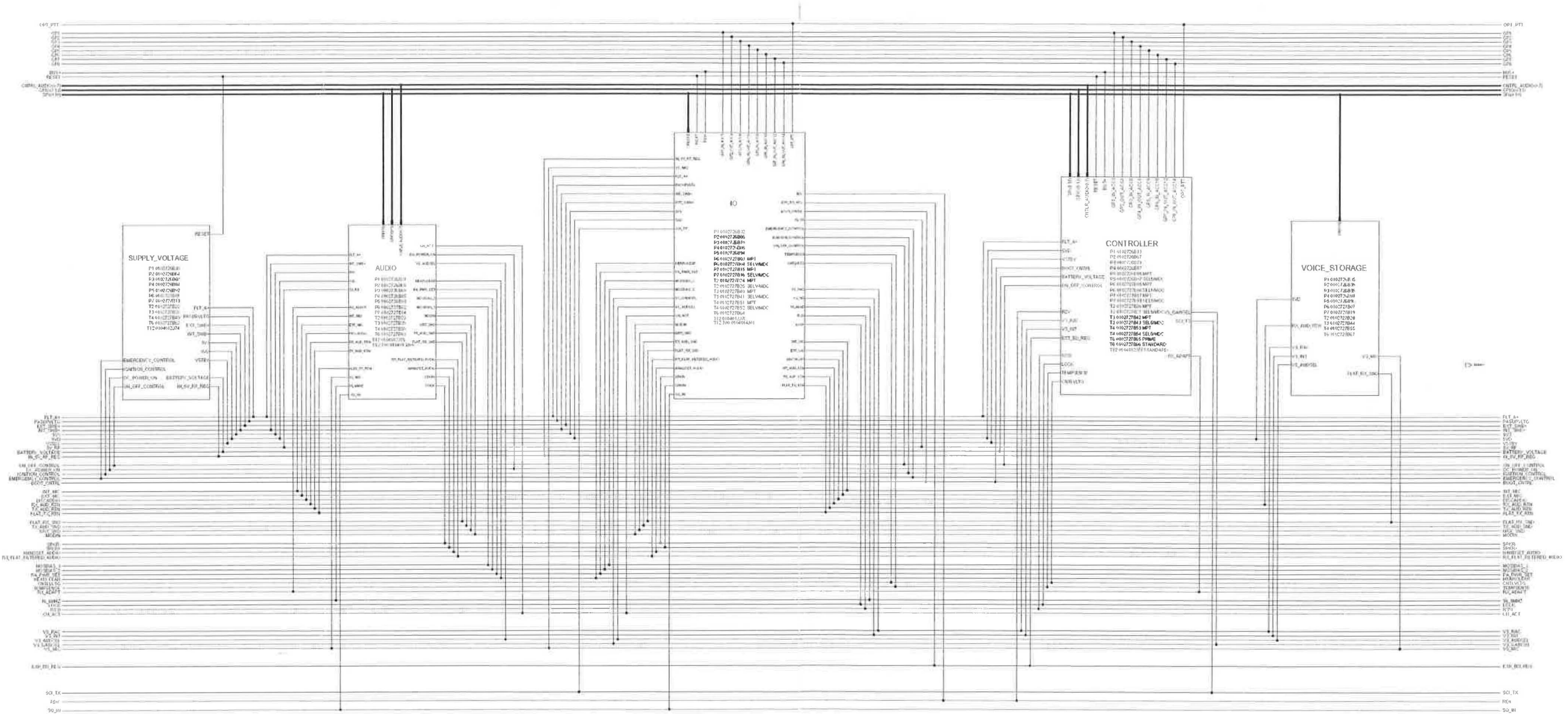

Figure 4-26. 700 MHz Overall Controller Schematic Diagram



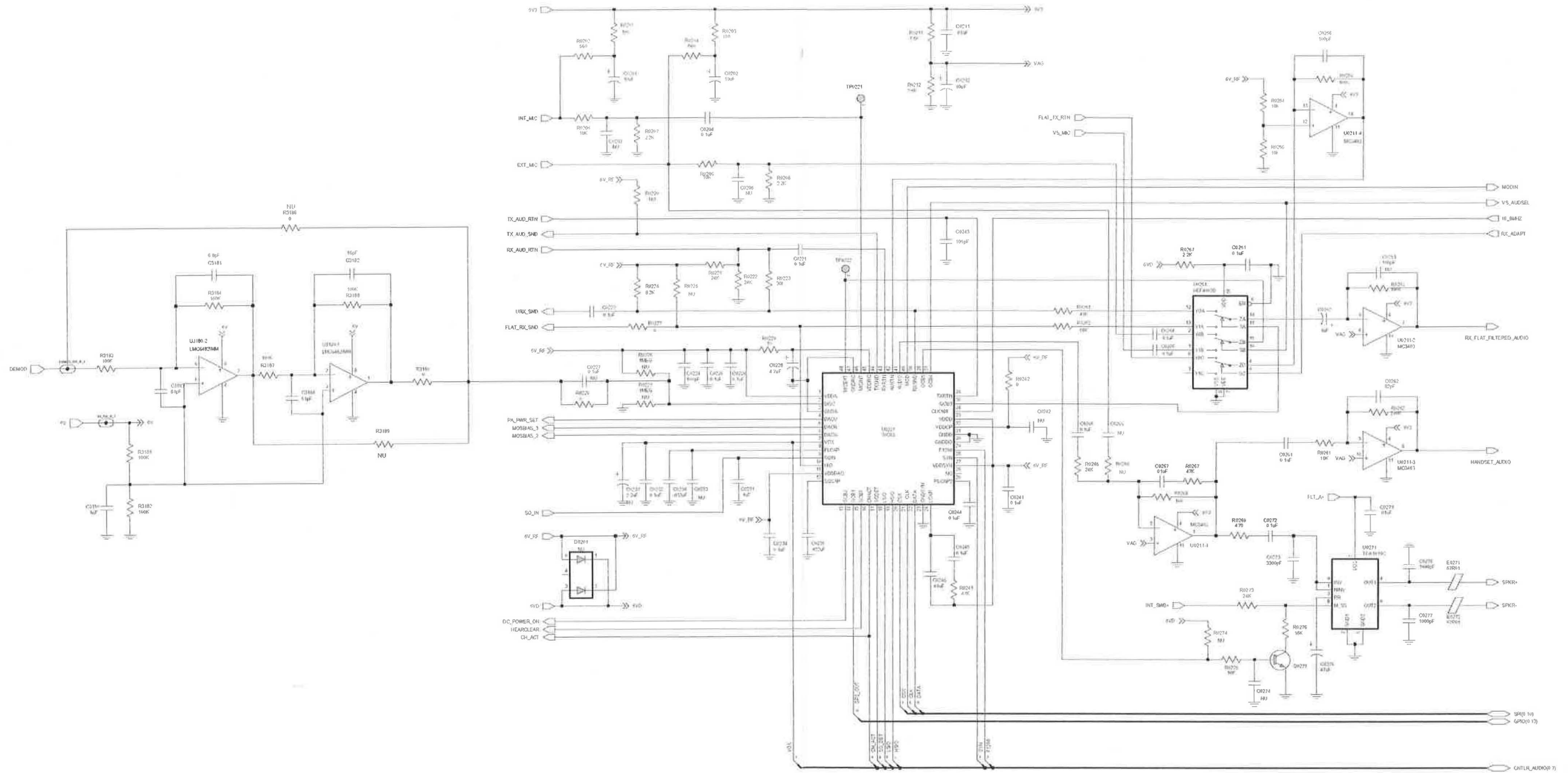

Figure 4-28. 700 MHz Audio Schematic Diagram



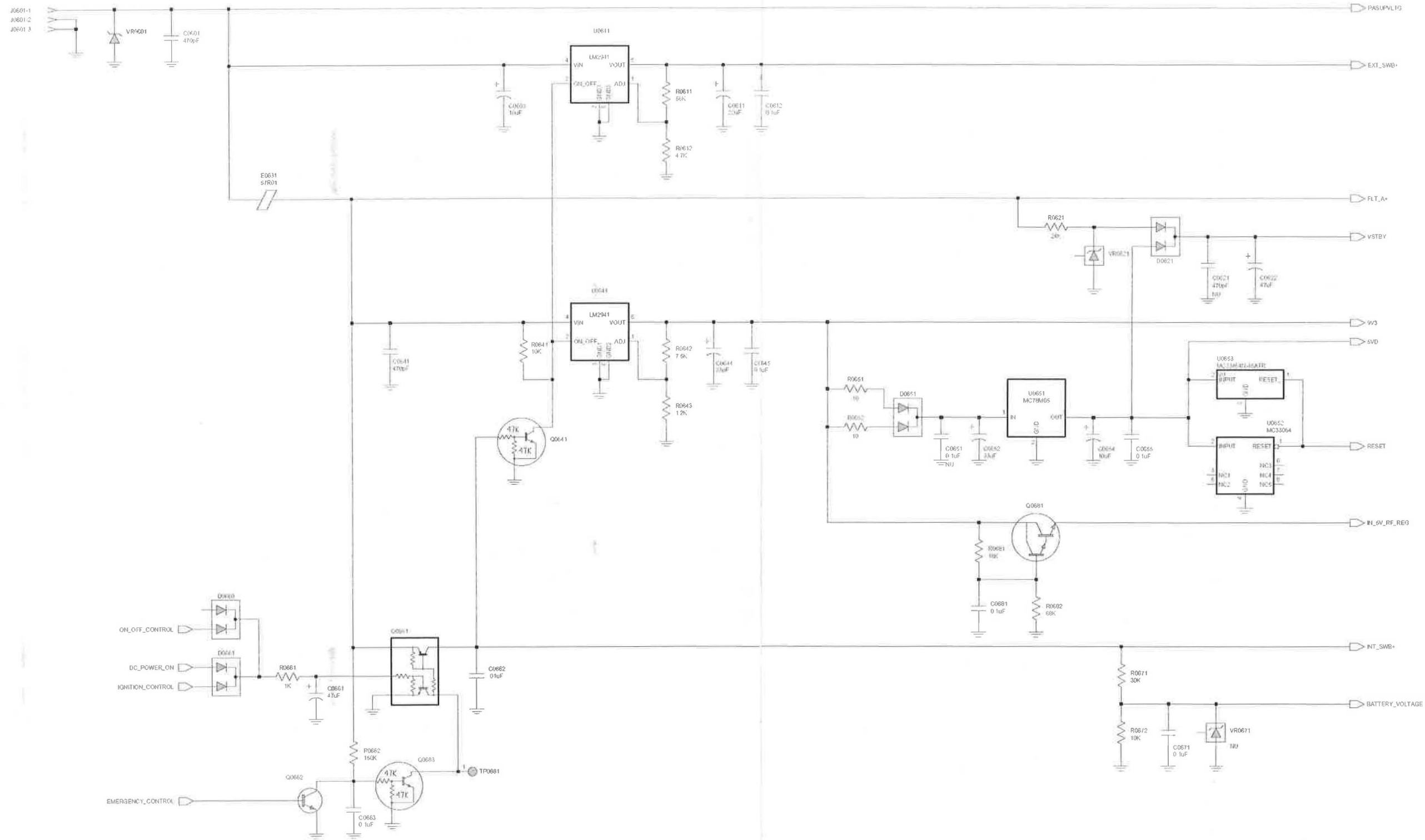

Figure 4-30. 700 MHz Power Supply Schematic Diagram



## 700 MHz Radio Parts List

| Circuit Ref | Motorola Part No. | Description                 |
|-------------|-------------------|-----------------------------|
| C0101       | 2113740F51        | 100 pF                      |
| C0102       |                   | not used                    |
| C0103       |                   | not used                    |
| C0104       |                   | not used                    |
| C0105       |                   | not used                    |
| C0106       |                   | not used                    |
| C0107       | 2113741F25        | 1000 pF                     |
| C0108       |                   | not used                    |
| C0111       |                   | not used                    |
| C0112       | 2113743E20        | 0.1 uF, $\pm 10\%$ ; 16 V   |
| C0121       | 2113743E20        | 0.1 uF, $\pm 10\%$ ; 16 V   |
| C0122       | 2113743E20        | 0.1 uF, $\pm 10\%$ ; 16 V   |
| C0123       |                   | not used                    |
| C0131       | 2113740F35        | 22 pF                       |
| C0132       | 2113740F35        | 22 pF                       |
| C0141       | 2113743E20        | 0.1 uF, $\pm 10\%$ ; 16 V   |
| C0151       | 2113741F49        | 0.01 uF, $\pm 5\%$ ; 50 V   |
| C0201       | 2311049A57        | 10 uF, $\pm 10\%$ ; 16 V    |
| C0202       | 2311049A57        | 10 uF, $\pm 10\%$ ; 16 V    |
| C0203       |                   | not used                    |
| C0204       | 2113743E20        | 0.1 uF, $\pm 10\%$ ; 16 V   |
| C0205       |                   | not used                    |
| C0211       | 2113741F49        | 0.01 uF, $\pm 5\%$ ; 50 V   |
| C0212       | 2311049A57        | 10 uF, $\pm 10\%$ ; 16 V    |
| C0221       | 2113743E20        | 0.1 uF, $\pm 10\%$ ; 16 V   |
| C0222       | 2113743E20        | 0.1 uF, $\pm 10\%$ ; 16 V   |
| C0224       | 2113740F51        | 100 pF                      |
| C0225       | 2113743E20        | 0.1 uF, $\pm 10\%$ ; 16 V   |
| C0226       | 2113743E20        | 0.1 uF, $\pm 10\%$ ; 16 V   |
| C0227       |                   | not used                    |
| C0228       | 2311049A56        | 4.7 uF, $\pm 20\%$ ; 10 V   |
| C0231       | 2113743B29        | 1 uF, $\pm 10\%$ ; 16 V     |
| C0232       | 2113743E20        | 0.1 uF, $\pm 10\%$ ; 16 V   |
| C0233       |                   | not used                    |
| C0234       | 2113743E20        | 0.1 uF, $\pm 10\%$ ; 16 V   |
| C0235       | 2113743E07        | 0.022 uF, $\pm 10\%$ ; 16 V |
| C0236       | 2113743E10        | 0.033 uF, $\pm 10\%$ ; 16 V |
| C0237       |                   | not used                    |
| C0241       | 2113743E20        | 0.1 uF, $\pm 10\%$ ; 16 V   |
| C0242       |                   | not used                    |
| C0243       | 2113740F51        | 100 pF                      |
| C0244       | 2113743E20        | 0.1 uF, $\pm 10\%$ ; 16 V   |
| C0245       | 2113743E20        | 0.1 uF, $\pm 10\%$ ; 16 V   |
| C0246       | 2113741F49        | 0.01 uF, $\pm 5\%$ ; 50 V   |
| C0251       | 2113743E20        | 0.1 uF, $\pm 10\%$ ; 16 V   |
| C0252       | 2311049A07        | 1 uF, $\pm 10\%$ ; 16 V     |
| C0253       |                   | not used                    |
| C0254       | 2113743E20        | 0.1 uF, $\pm 10\%$ ; 16 V   |
| C0255       | 2113743E20        | 0.1 uF, $\pm 10\%$ ; 16 V   |
| C0256       | 2113740F51        | 100 pF                      |

| Circuit Ref | Motorola Part No. | Description               |
|-------------|-------------------|---------------------------|
| C0261       | 2113743E20        | 0.1 uF, $\pm 10\%$ ; 16 V |
| C0262       | 2113740F49        | 82 pF                     |
| C0265       | 2113743E20        | 0.1 uF, $\pm 10\%$ ; 16 V |
| C0266       |                   | not used                  |
| C0267       | 2113741F49        | 0.01 uF, $\pm 5\%$ ; 50 V |
| C0271       | 2113741F49        | 0.01 uF, $\pm 5\%$ ; 50 V |
| C0272       | 2113743E20        | 0.1 uF, $\pm 10\%$ ; 16 V |
| C0273       | 2113741F37        | 3300 pF                   |
| C0274       |                   | not used                  |
| C0275       | 2311049A99        | 47 uF, $\pm 20\%$ ; 10 V  |
| C0276       | 2113741F25        | 1000 pF                   |
| C0277       | 2113741F25        | 1000 pF                   |
| C0421       | 2113743N48        | 82 pF                     |
| C0422       | 2113741F17        | 470 pF                    |
| C0423       | 2113741F17        | 470 pF                    |
| C0424       | 2113743L41        | 0.01 uF, $\pm 5\%$ ; 50 V |
| C0425       | 2113743L41        | 0.01 uF, $\pm 5\%$ ; 50 V |
| C0426       | 2113743L09        | 470 pF                    |
| C0427       | 2113743L09        | 470 pF                    |
| C0428       | 2113743N48        | 82 pF                     |
| C0429       | 2113743L09        | 470 pF                    |
| C0430       | 2113741F17        | 470 pF                    |
| C0431       | 2113741F17        | 470 pF                    |
| C0433       | 2113741F49        | 0.01 uF, $\pm 5\%$ ; 50 V |
| C0434       | 2113741F49        | 0.01 uF, $\pm 5\%$ ; 50 V |
| C0441       | 2113743L09        | 470 pF                    |
| C0442       | 2113743L09        | 470 pF                    |
| C0443       |                   | not used                  |
| C0445       | 2113743L09        | 470 pF                    |
| C0446       | 2113743L09        | 470 pF                    |
| C0447       | 2113743L09        | 470 pF                    |
| C0448       | 2113743L09        | 470 pF                    |
| C0449       | 2113743L09        | 470 pF                    |
| C0470       | 2113743L09        | 470 pF                    |
| C0471       | 2113743N48        | 82 pF                     |
| C0472       | 2113743N48        | 82 pF                     |
| C0473       | 2113743N48        | 82 pF                     |
| C0474       | 2113743L09        | 470 pF                    |
| C0476       | 2113743L09        | 470 pF                    |
| C0477       | 2113743L09        | 470 pF                    |
| C0478       | 2113743L09        | 470 pF                    |
| C0482       | 2113743L09        | 470 pF                    |
| C0483       | 2113743L09        | 470 pF                    |
| C0484       | 2113741F17        | 470 pF                    |
| C0485       | 2113743L09        | 470 pF                    |
| C0486       | 2113743L09        | 470 pF                    |
| C0487       | 2113743L09        | 470 pF                    |
| C0488       | 2113743L09        | 470 pF                    |
| C0490       | 2113743L09        | 470 pF                    |
| C0491       | 2113743L09        | 470 pF                    |
| C0492       | 2113743L09        | 470 pF                    |

| Circuit Ref | Motorola Part No. | Description                |
|-------------|-------------------|----------------------------|
| C0493       | 2113743L09        | 470 pF                     |
| C0494       | 2113743L09        | 470 pF                     |
| C0495       | 2113743L09        | 470 pF                     |
| C0496       | 2113743L09        | 470 pF                     |
| C0497       | 2113743L09        | 470 pF                     |
| C0499       | 2113743L09        | 470 pF                     |
| C0501       | 2113741F49        | 0.01 uF, $\pm 5\%$ ; 50 V  |
| C0502       | 2113741F17        | 470 pF                     |
| C0503       | 2113741F17        | 470 pF                     |
| C0504       | 2113741F17        | 470 pF                     |
| C0505       | 2113741F17        | 470 pF                     |
| C0506       | 2113741F17        | 470 pF                     |
| C0508       | 2113741F17        | 470 pF                     |
| C0509       | 2113741F17        | 470 pF                     |
| C0510       | 2113741F17        | 470 pF                     |
| C0511       | 2113741F17        | 470 pF                     |
| C0512       | 2113741F17        | 470 pF                     |
| C0513       | 2113741F17        | 470 pF                     |
| C0514       | 2113741F17        | 470 pF                     |
| C0515       | 2113741F17        | 470 pF                     |
| C0516       | 2113741F49        | 0.01 uF, $\pm 5\%$ ; 50 V  |
| C0517       | 2113743N48        | 82 pF                      |
| C0518       | 2113741F17        | 470 pF                     |
| C0541       | 2311049A05        | 0.47 uF, $\pm 10\%$ ; 25 V |
| C0542       | 2311049A99        | 47 uF, $\pm 20\%$ ; 10 V   |
| C0554       |                   | not used                   |
| C0558       |                   | not used                   |
| C0559       |                   | not used                   |
| C0560       | 2113743L17        | 1000 pF                    |
| C0575       |                   | not used                   |
| C0576       |                   | not used                   |
| C0591       | 2113743E20        | 0.1 uF, $\pm 10\%$ ; 16 V  |
| C0592       | 2113743E20        | 0.1 uF, $\pm 10\%$ ; 16 V  |
| C0601       | 2113741F17        | 470 pF                     |
| C0603       | 2380090M24        | 10 uF, $\pm 20\%$ ; 50 V   |
| C0611       | 2311049C06        | 22 uF, $\pm 20\%$ ; 35 V   |
| C0612       | 2113743E20        | 0.1 uF, $\pm 10\%$ ; 16 V  |
| C0621       |                   | not used                   |
| C0622       | 2311049A99        | 47 uF, $\pm 20\%$ ; 10 V   |
| C0641       | 2113741F17        | 470 pF                     |
| C0644       | 2311049A97        | 33 uF, $\pm 20\%$ ; 16 V   |
| C0645       | 2113743E20        | 0.1 uF, $\pm 10\%$ ; 16 V  |
| C0651       |                   | not used                   |
| C0652       | 2311049A97        | 33 uF, $\pm 20\%$ ; 16 V   |
| C0654       | 2311049A57        | 10 uF, $\pm 10\%$ ; 16 V   |
| C0655       | 2113743E20        | 0.1 uF, $\pm 10\%$ ; 16 V  |
| C0661       | 2311049C05        | 47 uF, $\pm 10\%$ ; 16 V   |
| C0662       | 2113741F49        | 0.01 uF, $\pm 5\%$ ; 50 V  |
| C0663       | 2113743E20        | 0.1 uF, $\pm 10\%$ ; 16 V  |
| C0671       | 2113743E20        | 0.1 uF, $\pm 10\%$ ; 16 V  |
| C0681       | 2113743E20        | 0.1 uF, $\pm 10\%$ ; 16 V  |

| Circuit Ref | Motorola Part No. | Description                 |
|-------------|-------------------|-----------------------------|
| C3000       | 2113740F44        | 51 pF                       |
| C3001       | 2113740F22        | 6.2 pF                      |
| C3002       | 2113740F44        | 51 pF                       |
| C3003       | 2113743E20        | 0.1 uF, $\pm 10\%$ ; 16 V   |
| C3004       | 2113741F25        | 1000 pF                     |
| C3005       | 2113740F44        | 51 pF                       |
| C3006       | 2113740F44        | 51 pF                       |
| C3007       | 2113741F25        | 1000 pF                     |
| C3008       | 2113740F44        | 51 pF                       |
| C3009       | 2113741F25        | 1000 pF                     |
| C3012       | 2113740F09        | 1.8 pF                      |
| C3013       | 2113740F44        | 51 pF                       |
| C3014       | 2113740F23        | 6.8 pF                      |
| C3015       | 2113740F09        | 1.8 pF                      |
| C3016       | 2113740F44        | 51 pF                       |
| C3017       | 2113740F38        | 30 pF                       |
| C3018       | 2113740F53        | 120 pF                      |
| C3019       |                   | not used                    |
| C3020       | 2113740F18        | 4.3 pF                      |
| C3021       | 2113740F18        | 4.3 pF                      |
| C3022       | 2113740F25        | 8.2 pF                      |
| C3023       | 2113740F28        | 11 pF                       |
| C3024       | 2113740F31        | 15 pF                       |
| C3025       |                   | not used                    |
| C3026       | 2113740F31        | 15 pF                       |
| C3027       | 2113740F22        | 6.2 pF                      |
| C3028       | 2113740F44        | 51 pF                       |
| C3029       |                   | not used                    |
| C3000       | 2113741F25        | 1000 pF                     |
| C3010       |                   | not used                    |
| C3102       | 2113740F06        | 1.3 pF                      |
| C3103       | 2113740F21        | 5.6 pF                      |
| C3104       | 2113743E20        | 0.1 uF, $\pm 10\%$ ; 16 V   |
| C3110       |                   | not used                    |
| C3111       | 2113743E20        | 0.1 uF, $\pm 10\%$ ; 16 V   |
| C3112       | 2113740F25        | 8.2 pF                      |
| C3113       | 2113740F21        | 5.6 pF                      |
| C3114       | 2113740F06        | 1.3 pF                      |
| C3115       | 2113740F25        | 8.2 pF                      |
| C3116       | 2113743E20        | 0.1 uF, $\pm 10\%$ ; 16 V   |
| C3121       | 2113743E20        | 0.1 uF, $\pm 10\%$ ; 16 V   |
| C3122       | 2113740F23        | 6.8 pF                      |
| C3123       | 2113743E11        | 0.039 uF, $\pm 10\%$ ; 16 V |
| C3124       | 2113740F34        | 20 pF                       |
| C3125       |                   | not used                    |
| C3126       | 2113740F33        | 18 pF                       |
| C3131       |                   | not used                    |
| C3132       | 2113743E20        | 0.1 uF, $\pm 10\%$ ; 16 V   |
| C3133       | 2311049A57        | 10 uF, $\pm 10\%$ ; 16 V    |
| C3134       | 2113743E20        | 0.1 uF, $\pm 10\%$ ; 16 V   |
| C3135       | 2113740F39        | 33 pF                       |

| Circuit Ref | Motorola Part No. | Description           |
|-------------|-------------------|-----------------------|
| C3136       | 2113740F31        | 15 pF                 |
| C3137       | 2113743E11        | 0.039 uF, ± 10%; 16 V |
| C3139       | 2113743E20        | 0.1 uF, ± 10%; 16 V   |
| C3140       | 2113743E20        | 0.1 uF, ± 10%; 16 V   |
| C3141       | 2113743E20        | 0.1 uF, ± 10%; 16 V   |
| C3142       | 2113743E20        | 0.1 uF, ± 10%; 16 V   |
| C3143       | 2113740F53        | 120 pF                |
| C3144       | 2113743E20        | 0.1 uF, ± 10%; 16 V   |
| C3145       | 2113743E20        | 0.1 uF, ± 10%; 16 V   |
| C3146       | 2113741F41        | 4700 pF               |
| C3147       | 2113743E20        | 0.1 uF, ± 10%; 16 V   |
| C3148       |                   | not used              |
| C3150       |                   | not used              |
| C3151       |                   | not used              |
| C3180       | 2113928E01        | 1 uF, ± 10%; 10 V     |
| C3181       | 2113740F23        | 6.8 pF                |
| C3182       | 2113740F32        | 16 pF                 |
| C3183       | 2113740F44        | 51 pF                 |
| C3184       | 2113740F44        | 51 pF                 |
| C3201       | 2113743E07        | 0.022 uF, ± 10%; 16 V |
| C3202       | 2311049A09        | 2.2 uF, ± 10%; 20 V   |
| C3203       | 2311049A57        | 10 uF, ± 10%; 16 V    |
| C3204       | 2311049A57        | 10 uF, ± 10%; 16 V    |
| C3205       | 2113741F49        | 0.01 uF, ± 5%; 50 V   |
| C3206       | 2113743E20        | 0.1 uF, ± 10%; 16 V   |
| C3207       | 2311049A09        | 2.2 uF, ± 10%; 20 V   |
| C3208       | 2113740F44        | 51 pF                 |
| C3209       | 2113740F44        | 51 pF                 |
| C3210       | 2113743E20        | 0.1 uF, ± 10%; 16 V   |
| C3211       | 2311049A40        | 2.2 uF, ± 10%; 10 V   |
| C3212       | 2113741F49        | 0.01 uF, ± 5%; 50 V   |
| C3213       | 2113741F49        | 0.01 uF, ± 5%; 50 V   |
| C3214       | 2311049A40        | 2.2 uF, ± 10%; 10 V   |
| C3215       | 2113740F35        | 22 pF                 |
| C3216       | 2113740F35        | 22 pF                 |
| C3217       | 2113740F45        | 56 pF                 |
| C3218       | 2113740F44        | 51 pF                 |
| C3219       | 2311049A40        | 2.2 uF, ± 10%; 10 V   |
| C3220       | 2113741F49        | 0.01 uF, ± 5%; 50 V   |
| C3221       | 2113741F49        | 0.01 uF, ± 5%; 50 V   |
| C3222       | 2113740F44        | 51 pF                 |
| C3223       | 2113740F44        | 51 pF                 |
| C3224       | 2113740F44        | 51 pF                 |
| C3225       | 2113740F44        | 51 pF                 |
| C3228       | 2311049A40        | 2.2 uF, ± 10%; 10 V   |
| C3229       |                   | not used              |
| C3230       | 2113740F44        | 51 pF                 |
| C3231       | 2113741F49        | 0.01 uF, ± 5%; 50 V   |
| C3232       | 2113740F44        | 51 pF                 |
| C3233       | 2113743T19        | 10 uF, ± 10%; 16 V    |
| C3234       | 2113741F49        | 0.01 uF, ± 5%; 50 V   |

| Circuit Ref | Motorola Part No. | Description           |
|-------------|-------------------|-----------------------|
| C3235       | 2113743E12        | 0.047 uF, ± 10%; 16 V |
| C3236       | 2113743E20        | 0.1 uF, ± 10%; 16 V   |
| C3237       | 2113743E12        | 0.047 uF, ± 10%; 16 V |
| C3238       | 2113741F17        | 470 pF                |
| C3239       | 2113740F44        | 51 pF                 |
| C3240       | 2113740F44        | 51 pF                 |
| C3241       | 2311049A01        | 0.1 uF, ± 10%; 16 V   |
| C3244       | 2113740F44        | 51 pF                 |
| C3245       | 2311049A05        | 0.47 uF, ± 10%; 25 V  |
| C3246       | 2113740F05        | 1.2 pF                |
| C3247       | 2113740F44        | 51 pF                 |
| C3248       | 2113740F44        | 51 pF                 |
| C3249       | 2113743E20        | 0.1 uF, ± 10%; 16 V   |
| C3250       | 2113743E20        | 0.1 uF, ± 10%; 16 V   |
| C3251       | 2113743E20        | 0.1 uF, ± 10%; 16 V   |
| C3252       | 2113743E20        | 0.1 uF, ± 10%; 16 V   |
| C3253       | 2113743E20        | 0.1 uF, ± 10%; 16 V   |
| C3301       | 2113743F18        | 2.2 uF, ± 80%; 16 V   |
| C3302       | 2113743E20        | 0.1 uF, ± 10%; 16 V   |
| C3303       | 2113743E20        | 0.1 uF, ± 10%; 16 V   |
| C3304       | 2113743E20        | 0.1 uF, ± 10%; 16 V   |
| C3305       | 2113740F44        | 51 pF                 |
| C3306       | 2113740F44        | 51 pF                 |
| C3307       | 2113743E10        | 0.033 uF, ± 10%; 16 V |
| C3308       | 2113740F44        | 51 pF                 |
| C3309       | 2113743E20        | 0.1 uF, ± 10%; 16 V   |
| C3310       | 2113740F44        | 51 pF                 |
| C3311       | 2113743E20        | 0.1 uF, ± 10%; 16 V   |
| C3312       |                   | not used              |
| C3313       | 2113741F49        | 0.01 uF, ± 5%; 50 V   |
| C3314       |                   | not used              |
| C3315       | 2113740F44        | 51 pF                 |
| C3316       |                   | not used              |
| C3317       | 2113740F44        | 51 pF                 |
| C3318       |                   | not used              |
| C3319       | 2113740L06        | 3.3 pF                |
| C3320       | 2113740L04        | 2.7 pF                |
| C3321       | 2113740F02        | 0.75 pF               |
| C3322       | 2113740L02        | 2.2 pF                |
| C3323       | 2113740F44        | 51 pF                 |
| C3324       | 2113740L04        | 2.7 pF                |
| C3326       | 2113740F30        | 13 pF                 |
| C3327       | 2113740F44        | 51 pF                 |
| C3328       | 2113743E20        | 0.1 uF, ± 10%; 16 V   |
| C3329       | 2113740F44        | 51 pF                 |
| C3330       | 2113740F44        | 51 pF                 |
| C3331       | 2113743E20        | 0.1 uF, ± 10%; 16 V   |
| C3332       | 2113743E20        | 0.1 uF, ± 10%; 16 V   |
| C3333       | 2113740F44        | 51 pF                 |
| C3334       | 2113740F44        | 51 pF                 |
| C3335       | 2113740F44        | 51 pF                 |

| Circuit Ref | Motorola Part No. | Description           |
|-------------|-------------------|-----------------------|
| C3336       | 2113740F44        | 51 pF                 |
| C3337       | 2113740F44        | 51 pF                 |
| C3338       | 2113740F44        | 51 pF                 |
| C3339       | 2113740L13        | 6.2 pF                |
| C3340       | 2113740F19        | 4.7 pF                |
| C3341       | 2113740F08        | 1.6 pF                |
| C3342       | 2113740F44        | 51 pF                 |
| C3343       | 2113740L06        | 3.3 pF                |
| C3344       | 2113740L01        | 2 pF                  |
| C3345       |                   | not used              |
| C3346       | 2113740F44        | 51 pF                 |
| C3348       | 2113740F51        | 100 pF                |
| C3349       | 2113740F01        | 0.5 pF                |
| C3350       |                   | not used              |
| C3351       | 2113740L01        | 2 pF                  |
| C3352       | 2113741F49        | 0.01 uF, ± 5%; 50 V   |
| C3353       | 2113740F44        | 51 pF                 |
| C3354       | 2113740F44        | 51 pF                 |
| C3355       | 2113740F44        | 51 pF                 |
| C3356       | 2113743E20        | 0.1 uF, ± 10%; 16 V   |
| C3357       | 2113743E20        | 0.1 uF, ± 10%; 16 V   |
| C3358       | 2113743E20        | 0.1 uF, ± 10%; 16 V   |
| C3401       | 2113740F45        | 56 pF                 |
| C3402       | 2113740F27        | 10 pF                 |
| C3403       | 2113740F51        | 100 pF                |
| C3404       | 2113741F49        | 0.01 uF, ± 5%; 50 V   |
| C3405       | 2113741F49        | 0.01 uF, ± 5%; 50 V   |
| C3406       | 2113740F44        | 51 pF                 |
| C3407       | 2113743E07        | 0.022 uF, ± 10%; 16 V |
| C3408       | 2113743E07        | 0.022 uF, ± 10%; 16 V |
| C3409       | 2113741F33        | 2200 pF               |
| C3410       | 2113740F44        | 51 pF                 |
| C3411       | 2113741F33        | 2200 pF               |
| C3412       | 2113740F44        | 51 pF                 |
| C3413       | 2113743E20        | 0.1 uF, ± 10%; 16 V   |
| C3420       |                   | not used              |
| C3421       | 2113740F31        | 15 pF                 |
| C3422       | 2113740F21        | 5.6 pF                |
| C3423       | 2113741F49        | 0.01 uF, ± 5%; 50 V   |
| C3424       | 2113740F44        | 51 pF                 |
| C3425       | 2113740A39        | 27 pF                 |
| C3426       | 2111078B10        | 7.5 pF                |
| C3427       | 2113741B69        | 0.1 uF, ± 10%; 16 V   |
| C3428       | 2113741W01        | 1 uF, ± 10%; 25 V     |
| C3429       | 2113740A49        | 56 pF                 |
| C3440       | 2111078B36        | 56 pF                 |
| C3441       | 2111078B07        | 5.6 pF                |
| C3442       | 2111078B08        | 6.2 pF                |
| C3443       | 2111078B11        | 8.2 pF                |
| C3444       |                   | not used              |
| C3445       | 2113740A49        | 56 pF                 |

| Circuit Ref | Motorola Part No. | Description           |
|-------------|-------------------|-----------------------|
| C3446       | 2113741F49        | 0.01 uF, ± 5%; 50 V   |
| C3447       | 2113740F44        | 51 pF                 |
| C3448       | 2111078B15        | 12 pF                 |
| C3449       | 2111078B01        | 3.3 pF                |
| C3450       | 2111078B11        | 8.2 pF                |
| C3451       |                   | not used              |
| C3452       | 2180060M01        | 1 pF                  |
| C3453       | 2111078B27        | 30 pF                 |
| C3460       | 2113740A49        | 56 pF                 |
| C3461       | 2113740A49        | 56 pF                 |
| C3462       | 2113741A45        | 0.01 uF, ± 5%; 50 V   |
| C3463       | 2311049A45        | 10 uF, ± 10%; 35 V    |
| C3464       | 2113741M69        | 0.1 uF, ± 10%; 16 V   |
| C3465       | 2113740F44        | 51 pF                 |
| C3466       | 2113740F44        | 51 pF                 |
| C3467       | 2113741W01        | 1 uF, ± 10%; 25 V     |
| C3468       | 2113740A49        | 56 pF                 |
| C3470       | 2113740F44        | 51 pF                 |
| C3471       | 2111078B32        | 39 pF                 |
| C3472       |                   | not used              |
| C3473       | 2180060M01        | 1 pF                  |
| C3474       | 2113740F44        | 51 pF                 |
| C3475       | 2111078B10        | 7.5 pF                |
| C3476       | 2111078B09        | 6.8 pF                |
| C3477       | 2113740F44        | 51 pF                 |
| C3478       | 2113743E07        | 0.022 uF, ± 10%; 16 V |
| C3480       | 2111078B32        | 39 pF                 |
| C3481       | 2111078B04        | 4.3 pF                |
| C3482       | 2111078B03        | 3.9 pF                |
| C3483       |                   | not used              |
| C3484       | 2113740F44        | 51 pF                 |
| C3485       | 2113740F44        | 51 pF                 |
| C3486       |                   | not used              |
| C3487       | 2113740F09        | 1.8 pF                |
| C3488       | 2113740F44        | 51 pF                 |
| C3489       | 2113743E20        | 0.1 uF, ± 10%; 16 V   |
| C3490       | 2113740F44        | 51 pF                 |
| C3491       | 2180060M03        | 2 pF                  |
| C3492       | 2180060M03        | 2 pF                  |
| C3493       | 2111078B01        | 3.3 pF                |
| C3501       | 2113741F33        | 2200 pF               |
| C3502       | 2113741F17        | 470 pF                |
| C3503       | 2113743E03        | 0.015 uF, ± 10%; 16 V |
| C3504       | 2113741F33        | 2200 pF               |
| C3505       | 2311049A07        | 1 uF, ± 10%; 16 V     |
| C3506       | 2113740F44        | 51 pF                 |
| C3507       | 2113741F33        | 2200 pF               |
| C3508       | 2113741F25        | 1000 pF               |
| C3509       | 2113741F33        | 2200 pF               |
| C3510       | 2113741F33        | 2200 pF               |
| C3511       | 2113740F44        | 51 pF                 |

| Circuit Ref | Motorola Part No. | Description                    | Circuit Ref | Motorola Part No. | Description                     | Circuit Ref | Motorola Part No. | Description           | Circuit Ref | Motorola Part No. | Description           |
|-------------|-------------------|--------------------------------|-------------|-------------------|---------------------------------|-------------|-------------------|-----------------------|-------------|-------------------|-----------------------|
| C3512       | 2113740F44        | 51 pF                          | J0551       | 0905505Y04        | Connector, 40-pin, Option Board | L3402       | 2413926H23        | 82 nH                 | Q3420       | 4813828A09        | MRF1517               |
| C3513       | 2113740F44        | 51 pF                          | J0552       | 0905505Y03        | Connector, 18-pin, RS232        | L3403       | 2413926H23        | 82 nH                 | Q3440       | 0104014J28        | MRF9045               |
| C3514       | 2113740F44        | 51 pF                          | J0601       | 0986165B01        | DC Power Connector              | L3404       | 2484657R01        | Ferrite Bead          | Q3470       | 4880048M01        | Digital NPN DTC144EKA |
| C3515       | 2113740F44        | 51 pF                          | J3401       | 0986166B02        | Mini-UHF RF Connector           | L3405       | 2413926G12        | 27 nH                 | Q3471       | 4805128M27        | BSR33 PNP             |
| C3517       | 2113740F44        | 51 pF                          | L0481       |                   | not used                        | L3420       | 2462587T05        | 15 nH                 | Q3501       | 4880048M01        | Digital NPN DTC144EKA |
| C3518       | 2113740F44        | 51 pF                          | L0482       |                   | not used                        | L3421       | 2484657R01        | Ferrite Bead          | Q3502       | 4880048M01        | Digital NPN DTC144EKA |
| CR3000      | 4880154K03        | Dual Schottky Diode            | L3001       | 2413926H07        | 3.9 nH                          | L3422       | 2484562T05        | 18.5 nH               | Q3503       | 4805921T02        | Dual NPN/PNP          |
| CR3001      | 4802245J92        | Quad Crossover Diode Mixer     | L3002       | 2462587N56        | 180 nH                          | L3423       | 2409348J02        | 2.55 nH               | Q3510       | 4809939C05        | Dual NPN/PNP          |
| CR3201      | 4802021P13        | 2.9V Zener                     | L3003       | 2413926H12        | 10 nH                           | L3441       | 2462587T05        | 15 nH                 | Q3511       | 4813824A17        | MMBT3906 PNP          |
| CR3301      | 4862824C01        | Varactor                       | L3004       | 2413926H06        | 3.3 nH                          | L3442       | 2479990A01        | 4.22 nH               | R0101       | 0662057A73        | 10 K                  |
| CR3302      | 4862824C01        | Varactor                       | L3005       | 2462587N56        | 180 nH                          | L3443       | 2484657R01        | Ferrite Bead          | R0102       | 0662057A65        | 4.7 K                 |
| CR3303      | 4862824C01        | Varactor                       | L3006       | 2462587T26        | 680 nH                          | L3444       | 2484657R01        | Ferrite Bead          | R0103       | 0662057A01        | 10                    |
| D0101       | 4813825A05        | Schottky Diode                 | L3007       | 2462587T17        | 150 nH                          | L3470       | 2460591E77        | 30 nH                 | R0104       | 0662057A73        | 10 K                  |
| D0151       | 4813833C02        | Dual Diode Common Cathode      | L3008       | 2409348J11        | 5.45 nH                         | L3471       | 2462587T37        | 18 nH                 | R0105       | 0662057A97        | 100 K                 |
| D0179       | 4813833C02        | Dual Diode Common Cathode      | L3009       | 2409348J11        | 5.45 nH                         | L3472       | 2460591A77        | 10.40 nH              | R0106       |                   | not used              |
| D0201       |                   | not used                       | L3100       |                   | not used                        | L3473       | 2462587T18        | 180 nH                | R0107       |                   | not used              |
| D0621       | 4813833C02        | Dual Diode Common Cathode      | L3101       | 2462587T25        | 620 nH                          | L3474       | 2460591B73        | 12.77 nH              | R0108       | 0662057A57        | 2.2 K                 |
| D0651       | 4813833C02        | Dual Diode Common Cathode      | L3102       | 2462587T25        | 620 nH                          | L3475       | 2460591C53        | 15.57 nH              | R0110       |                   | not used              |
| D0660       | 4813833C02        | Dual Diode Common Cathode      | L3103       | 2462587T25        | 620 nH                          | L3476       | 2460591B73        | 12.77 nH              | R0111       | 0662057B47        | 0                     |
| D0661       | 4813833C02        | Dual Diode Common Cathode      | L3104       | 2413923A13        | 560 nH                          | L3477       | 2462587V26        | 22 nH                 | R0112       |                   | not used              |
| D3000       | 4880142L01        | Diode                          | L3105       | 2413923A12        | 470 nH                          | L3478       | 2462587V25        | 18 nH                 | R0113       | 0662057A73        | 10 K                  |
| D3101       | 4880154K03        | Dual Schottky Diode            | L3106       | 2462587Q42        | 390 nH                          | L3479       | 2479990A01        | 4.22 nH               | R0114       | 0662057A73        | 10 K                  |
| D3201       | 4802233J09        | Triple Diode                   | L3201       | 2462587Q20        | 2.2 uH                          | M3420       | 2686201B01        | PA Heatsink           | R0115       | 0662057A73        | 10 K                  |
| D3202       | 4813825A05        | Diode                          | L3202       | 2462587Q08        | 220 nH                          | Q0110       | 4880048M01        | Digital NPN DTC144EKA | R0116       |                   | not used              |
| D3470       | 4808379X02        | Diode                          | L3203       | 2462587P25        | 12 uH                           | Q0151       | 4880048M01        | Digital NPN DTC144EKA | R0117       | 0662057A63        | 3.9 K                 |
| D3471       | 4808379X02        | Diode                          | L3204       | 2462587P25        | 12 uH                           | Q0171       | 4880048M01        | Digital NPN DTC144EKA | R0121       | 0662057A97        | 100 K                 |
| D3472       | 4882290T02        | Dual Schottky Diode            | L3205       | 2462587V20        | 3.3 nH                          | Q0173       | 4880052M01        | Digital NPN DTC144EKA | R0131       | 0662057B46        | 10 MEG                |
| D3473       | 4813825A05        | Diode                          | L3301       | 2413926G19        | 100 nH                          | Q0177       | 4880048M01        | Digital NPN DTC144EKA | R0132       | 0662057B10        | 330 K                 |
| D3501       |                   | not used                       | L3302       | 2413926G09        | 15 nH                           | Q0181       | 4880048M01        | Digital NPN DTC144EKA | R0151       | 0662057A82        | 24 K                  |
| E0271       | 2484657R01        | Ferrite Bead                   | L3303       | 2413926G06        | 8.2 nH                          | Q0183       | 4880048M01        | Digital NPN DTC144EKA | R0152       | 0662057A82        | 24 K                  |
| E0272       | 2484657R01        | Ferrite Bead                   | L3304       | 2462587V41        | 390 nH                          | Q0185       | 4880048M01        | Digital NPN DTC144EKA | R0170       | 0662057A73        | 10 K                  |
| E0631       | 2484657R01        | Ferrite Bead                   | L3305       | 2462587V37        | 180 nH                          | Q0271       | 4880214G02        | MMBT3904 NPN          | R0171       | 0662057A65        | 4.7 K                 |
| E3000       | 2462586G40        | Ferrite Bead                   | L3306       | 2462587V37        | 180 nH                          | Q0641       | 4880048M01        | Digital NPN DTC144EKA | R0172       | 0662057A73        | 10 K                  |
| E3100       | 2462586G40        | Ferrite Bead                   | L3307       | 2413926G15        | 47 nH                           | Q0661       | 4805921T02        | Dual NPN/PNP          | R0173       | 0662057A65        | 4.7 K                 |
| E3101       | 2462586G40        | Ferrite Bead                   | L3308       | 2462587N45        | 22 nH                           | Q0662       | 4880214G02        | MMBT3904 NPN          | R0174       | 0662057A73        | 10 K                  |
| E3500       | 2462586G40        | Ferrite Bead                   | L3309       | 2462587V37        | 180 nH                          | Q0663       | 4880048M01        | Digital NPN DTC144EKA | R0175       | 0662057A73        | 10 K                  |
| F0401       | 6580542Z01        | Fuse 3A                        | L3310       | 2462587V28        | 33 nH                           | Q0681       | 4880052M01        | Digital NPN DTC144EKA | R0176       | 0662057A84        | 30 K                  |
| FL3000      | 4802245J91        | 3 Pole Ceramic Bandpass Filter | L3311       | 2462587V37        | 180 nH                          | Q3000       |                   | not used              | R0177       | 0662057A65        | 4.7 K                 |
| FL3001      | 4802245J91        | 3 Pole Ceramic Bandpass Filter | L3312       | 2462587N56        | 180 nH                          | Q3001       | 4802245J56        | QSTB0048 NPN          | R0178       | 0662057A89        | 47 K                  |
| FL3101      | 4802655J04        | 73.35 MHz IF Crystal Filter    | L3313       | 2462587V37        | 180 nH                          | Q3003       | 4809939C05        | Dual NPN/PNP          | R0179       | 0662057A89        | 47 K                  |
| FL3102      | 4802655J04        | 73.35 MHz IF Crystal Filter    | L3314       | 2413926G19        | 100 nH                          | Q3101       | 4802197J95        | PBR941 NPN            | R0181       | 0662057A65        | 4.7 K                 |
| FL3111      | 9180469V03        | 4-Pole 455 kHz Ceramic Filter  | L3315       | 2462587N42        | 12 nH                           | Q3102       | 4802197J95        | PBR941 NPN            | R0182       | 0662057A89        | 47 K                  |
| FL3113      | 9180468V04        | 6-Pole 455 kHz Ceramic Filter  | L3316       | 2413926G19        | 100 nH                          | Q3141       | 4880214G02        | MMBT3904 NPN          | R0183       | 0662057A65        | 4.7 K                 |
| J0401       | 0902636Y02        | Connector, Flex, 12-pin        | L3317       | 2462587N40        | 8.2 nH                          | Q3201       | 4880048M01        | Digital NPN DTC144EKA | R0184       | 0662057A89        | 47 K                  |
| J0451       | 0902636Y01        | Connector, Flex, Side Entry    | L3318       | 2462587V25        | 18 nH                           | Q3301       | 4802197J95        | PBR941 NPN            | R0185       | 0662057A65        | 4.7 K                 |
| J0501       | 0986105B01        | Connector, 20-pin, Accessory   | L3319       | 2462587V30        | 47 nH                           | Q3302       | 4802197J95        | PBR941 NPN            | R0186       | 0662057A89        | 47 K                  |
|             |                   |                                | L3320       | 2413926G10        | 18 nH                           | Q3303       | 4809939C05        | Dual NPN/PNP          | R0201       | 0662057A25        | 100                   |
|             |                   |                                | L3321       | 2462587V30        | 47 nH                           | Q3304       | 4805218N63        | BFQ67W NPN            | R0202       | 0662057A43        | 560                   |
|             |                   |                                | L3322       | 2413926G19        | 100 nH                          | Q3305       | 4805793Y01        | NEC NPN               | R0203       | 0662057A25        | 100                   |
|             |                   |                                | L3323       | 2462586G40        | Ferrite Bead                    | Q3306       | 4805793Y01        | NEC NPN               | R0204       | 0662057A43        | 560                   |
|             |                   |                                | L3401       | 2413926G05        | 6.8 nH                          | Q3307       | 4809939C05        | Dual NPN/PNP          | R0205       | 0662057A73        | 10 K                  |

| Circuit Ref | Motorola Part No. | Description |
|-------------|-------------------|-------------|
| R0206       | 0662057A73        | 10 K        |
| R0207       | 0662057A57        | 2.2 K       |
| R0208       | 0662057A57        | 2.2 K       |
| R0211       | 0660076E70        | 7.5 K       |
| R0212       | 0660076E70        | 7.5 K       |
| R0220       |                   | not used    |
| R0221       | 0662057A82        | 24 K        |
| R0222       | 0662057A82        | 24 K        |
| R0223       | 0662057A84        | 30 K        |
| R0224       | 0662057A71        | 8.2 K       |
| R0225       |                   | not used    |
| R0226       |                   | not used    |
| R0227       |                   | not used    |
| R0228       | 0662057B47        | 0           |
| R0229       | 0662057A01        | 10          |
| R0241       | 0662057A89        | 47 K        |
| R0242       | 0662057B47        | 0           |
| R0251       | 0662057A89        | 47 K        |
| R0252       | 0662057A91        | 56 K        |
| R0253       | 0662057A97        | 100 K       |
| R0254       | 0662057A73        | 10 K        |
| R0255       | 0662057A73        | 10 K        |
| R0256       | 0662057A97        | 100 K       |
| R0257       | 0662057A57        | 2.2 K       |
| R0261       | 0662057A73        | 10 K        |
| R0262       | 0662057B08        | 270 K       |
| R0265       | 0662057A82        | 24 K        |
| R0266       |                   | not used    |
| R0267       | 0662057A89        | 47 K        |
| R0268       | 0662057A73        | 10 K        |
| R0269       | 0662057A41        | 470         |
| R0273       | 0662057A82        | 24 K        |
| R0274       |                   | not used    |
| R0275       | 0662057A73        | 10 K        |
| R0276       | 0662057A77        | 15 K        |
| R0277       | 0662057B47        | 0           |
| R0401       | 0662057A33        | 220         |
| R0407       | 0662057M26        | 10          |
| R0408       | 0662057A25        | 100         |
| R0409       | 0662057M26        | 10          |
| R0412       | 0662057B47        | 0           |
| R0441       | 0662057B47        | 0           |
| R0442       | 0662057A49        | 1 K         |
| R0467       | 0662057M26        | 10          |
| R0468       | 0662057A97        | 100 K       |
| R0481       | 0662057B47        | 0           |
| R0482       | 0662057B47        | 0           |
| R0508       | 0662057A41        | 470         |
| R0509       | 0662057B47        | 0           |
| R0510       | 0662057A65        | 4.7 K       |
| R0511       | 0662057A97        | 100 K       |

| Circuit Ref | Motorola Part No. | Description |
|-------------|-------------------|-------------|
| R0512       | 0662057A77        | 15 K        |
| R0525       | 0662057A97        | 100 K       |
| R0529       | 0662057A89        | 47 K        |
| R0530       | 0662057A81        | 22 K        |
| R0531       | 0662057A43        | 560         |
| R0533       | 0662057B47        | 0           |
| R0535       | 0662057A49        | 1 K         |
| R0537       | 0662057A33        | 220         |
| R0538       | 0662057A33        | 220         |
| R0539       | 0662057A65        | 4.7 K       |
| R0541       | 0662057A83        | 27 K        |
| R0542       |                   | not used    |
| R0543       | 0662057A97        | 100 K       |
| R0555       | 0662057A25        | 100         |
| R0556       | 0662057A25        | 100         |
| R0591       | 0662057A82        | 24 K        |
| R0592       | 0662057A01        | 10          |
| R0593       | 0662057A97        | 100 K       |
| R0594       | 0611077A01        | 0           |
| R0611       | 0662057A91        | 56 K        |
| R0612       | 0662057A65        | 4.7 K       |
| R0621       | 0662057A82        | 24 K        |
| R0641       | 0662057A73        | 10 K        |
| R0642       | 0660076E70        | 7.5 K       |
| R0643       | 0660076E51        | 1.2 K       |
| R0651       | 0662057A01        | 10          |
| R0652       | 0662057A01        | 10          |
| R0661       | 0662057A49        | 1 K         |
| R0662       | 0662057B02        | 150 K       |
| R0671       | 0662057A84        | 30 K        |
| R0672       | 0662057A73        | 10 K        |
| R0681       | 0662057A79        | 18 K        |
| R0682       | 0662057A93        | 68 K        |
| R3000       | 0662057B47        | 0           |
| R3001       | 0662057A63        | 3.9 K       |
| R3002       | 0662057B47        | 0           |
| R3003       | 0662057A37        | 330         |
| R3004       | 0662057A57        | 2.2 K       |
| R3005       |                   | not used    |
| R3006       |                   | not used    |
| R3007       | 0662057A34        | 240         |
| R3008       | 0662057A34        | 240         |
| R3009       |                   | not used    |
| R3010       | 0662057B47        | 0           |
| R3011       |                   | not used    |
| R3012       | 0662057A40        | 430         |
| R3013       | 0662057A25        | 100         |
| R3014       | 0662057A18        | 51          |
| R3101       | 0662057A75        | 12 K        |
| R3102       | 0662057A01        | 10          |
| R3106       | 0662057A83        | 27 K        |

| Circuit Ref | Motorola Part No. | Description |
|-------------|-------------------|-------------|
| R3107       | 0662057A65        | 4.7 K       |
| R3108       | 0662057A57        | 2.2 K       |
| R3111       | 0662057A75        | 12 K        |
| R3112       | 0662057A01        | 10          |
| R3113       |                   | not used    |
| R3116       | 0662057A57        | 2.2 K       |
| R3117       | 0662057A83        | 27 K        |
| R3118       | 0662057A65        | 4.7 K       |
| R3123       |                   | not used    |
| R3124       | 0662057A47        | 820         |
| R3130       | 0662057A18        | 51          |
| R3132       | 0662057A55        | 1.8 K       |
| R3133       | 0662057A67        | 5.6 K       |
| R3134       | 0662057A73        | 10 K        |
| R3135       | 0662057A51        | 1.2 K       |
| R3141       | 0662057A39        | 390         |
| R3142       | 0662057A55        | 1.8 K       |
| R3143       | 0662057A65        | 4.7 K       |
| R3144       | 0662057A58        | 2.4 K       |
| R3145       | 0662057A61        | 3.3 K       |
| R3146       | 0662057A45        | 680         |
| R3147       | 0662057A75        | 12 K        |
| R3181       | 0662057A97        | 100 K       |
| R3182       | 0662057A97        | 100 K       |
| R3183       | 0662057A97        | 100 K       |
| R3184       | 0662057B02        | 150 K       |
| R3185       | 0662057B47        | 0           |
| R3186       |                   | not used    |
| R3187       | 0662057A97        | 100 K       |
| R3188       | 0662057A97        | 100 K       |
| R3189       |                   | not used    |
| R3201       | 0662057B47        | 0           |
| R3202       |                   | not used    |
| R3203       | 0662057A17        | 47          |
| R3204       |                   | not used    |
| R3205       | 0662057A25        | 100         |
| R3206       | 0662057A17        | 47          |
| R3207       | 0662057A17        | 47          |
| R3210       |                   | not used    |
| R3211       | 0662057A84        | 30 K        |
| R3212       |                   | not used    |
| R3213       | 0662057A91        | 56 K        |
| R3214       | 0662057A37        | 330         |
| R3215       | 0662057A51        | 1.2 K       |
| R3216       | 0662057A89        | 47 K        |
| R3217       | 0662057A25        | 100         |
| R3218       | 0662057A27        | 120         |
| R3219       | 0662057A63        | 3.9 K       |
| R3220       | 0662057A13        | 33          |
| R3221       | 0662057A31        | 180         |
| R3301       | 0662057A73        | 10 K        |

| Circuit Ref | Motorola Part No. | Description |
|-------------|-------------------|-------------|
| R3302       | 0662057A09        | 22          |
| R3303       | 0662057A17        | 47          |
| R3304       | 0662057A21        | 68          |
| R3305       | 0662057A97        | 100 K       |
| R3307       | 0662057A13        | 33          |
| R3308       | 0662057A02        | 11          |
| R3309       | 0662057A78        | 16 K        |
| R3310       | 0662057A13        | 33          |
| R3311       | 0662057A07        | 18          |
| R3312       | 0662057A25        | 100         |
| R3313       | 0662057A82        | 24 K        |
| R3314       | 0662057A25        | 100         |
| R3315       | 0662057A25        | 100         |
| R3316       | 0662057A01        | 10          |
| R3317       | 0662057A13        | 33          |
| R3318       | 0662057A73        | 10 K        |
| R3319       | 0662057A35        | 270         |
| R3320       | 0662057A26        | 110         |
| R3321       | 0662057A30        | 160         |
| R3323       | 0662057A13        | 33          |
| R3324       | 0662057A81        | 22 K        |
| R3325       | 0662057A13        | 33          |
| R3326       | 0662057A77        | 15 K        |
| R3327       | 0662057A77        | 15 K        |
| R3328       | 0662057A85        | 33 K        |
| R3329       | 0662057A17        | 47          |
| R3330       | 0662057A01        | 10          |
| R3331       | 0662057A07        | 18          |
| R3332       | 0662057A17        | 47          |
| R3333       | 0662057A65        | 4.7 K       |
| R3334       | 0662057A65        | 4.7 K       |
| R3335       | 0662057A13        | 33          |
| R3336       | 0662057A35        | 270         |
| R3337       | 0662057A31        | 180         |
| R3338       | 0662057A30        | 160         |
| R3341       | 0662057A84        | 30 K        |
| R3401       | 0662057A35        | 270         |
| R3402       | 0662057A07        | 18          |
| R3403       | 0662057A35        | 270         |
| R3404       | 0662057A29        | 150         |
| R3420       | 0662057B67        | 6.2         |
| R3421       | 0662057B67        | 6.2         |
| R3422       | 0662057B67        | 6.2         |
| R3423       | 0662057B67        | 6.2         |
| R3424       | 0662057B67        | 6.2         |
| R3425       | 0662057C44        | 51          |
| R3426       |                   | not used    |
| R3439       | 0662057C51        | 100         |
| R3440       | 0662057C51        | 100         |
| R3441       |                   | not used    |
| R3470       | 0680194M18        | 51          |

| Circuit Ref | Motorola Part No. | Description          |
|-------------|-------------------|----------------------|
| R3471       | 0662057A73        | 10 K                 |
| R3472       | 0680194M18        | 51                   |
| R3473       | 0662057A41        | 470                  |
| R3475       | 0662057A89        | 47 K                 |
| R3476       |                   | not used             |
| R3477       | 0683962T51        | 120                  |
| R3478       | 0662057A49        | 1 K                  |
| R3479       |                   | not used             |
| R3480       | 0683962T51        | 120                  |
| R3481       | 0662057B47        | 0                    |
| R3482       | 0662057C85        | 2.7 K                |
| R3483       | 0662057A18        | 51                   |
| R3484       | 0662057A73        | 10 K                 |
| R3485       | 0662057A97        | 100 K                |
| R3501       |                   | not used             |
| R3502       | 0662057B09        | 300 K                |
| R3503       | 0662057A73        | 10 K                 |
| R3504       | 0662057A69        | 6.8 K                |
| R3505       | 0662057A87        | 39 K                 |
| R3506       | 0662057A97        | 100 K                |
| R3507       | 0662057A49        | 1 K                  |
| R3508       | 0662057A80        | 20 K                 |
| R3509       | 0662057B47        | 0                    |
| R3510       | 0662057A87        | 39 K                 |
| R3511       | 0662057A57        | 2.2 K                |
| R3512       | 0662057A87        | 39 K                 |
| R3513       | 0662057C13        | 2.7                  |
| R3514       | 0662057A58        | 2.4 K                |
| R3515       |                   | not used             |
| R3516       | 0662057A87        | 39 K                 |
| R3517       |                   | not used             |
| R3518       | 0662057C13        | 2.7                  |
| R3519       | 0662057C13        | 2.7                  |
| R3520       | 0662057C13        | 2.7                  |
| R3521       | 0662057C13        | 2.7                  |
| R3522       |                   | not used             |
| R3523       | 0662057A87        | 39 K                 |
| R3524       |                   | not used             |
| R3525       | 0662057A81        | 22 K                 |
| R3526       | 0662057A73        | 10 K                 |
| R3527       | 0662057A73        | 10 K                 |
| R3528       | 0662057A97        | 100 K                |
| R3529       |                   | not used             |
| R3530       | 0662057B47        | 0                    |
| R3531       |                   | not used             |
| R3532       | 0662057A65        | 4.7 K                |
| SH3000      | 2680554Z01        | Shield, FE Top       |
| SH3001      | 2680509Z01        | Shield, FE Bottom    |
| SH3002      | 2680554Z01        | Shield, FE Top       |
| SH3201      | 2686081B02        | Shield, FracN Bottom |
| SH3202      | 2686081B02        | Shield, FracN Top    |

| Circuit Ref | Motorola Part No. | Description                            |
|-------------|-------------------|--|
| SH3301      | 2602641Y02        | Shield, VCO Bottom                     |
| SH3302      | 2602641Y02        | Shield, VCO Top                        |
| T3001       | 2580541Z02        | Mixer Balun                            |
| T3002       | 2580541Z02        | Mixer Balun                            |
| U0101       | 5102226J56        | Microcontroller<br>MC68HC11FL0         |
| U0111       | 5102463J64        | EEPROM X25128-2.7                      |
| U0121       | 5186137B01        | 512K x 8bit Flash ROM                  |
| U0122       | 5185748L01        | 32K x 8bit SRAM                        |
| U0141       | 5113805A30        | Demux MC74HC138A                       |
| U0211       | 5183222M49        | Quad Opamp MC3403                      |
| U0221       | 5185130C53        | ASFIC Audio Filter IC                  |
| U0251       | 5184704M60        | Mux/Demux HEF4053B                     |
| U0271       | 5102463J95        | Audio Power Amp TDA1519C               |
| U0611       | 5183308X01        | Adjustable Voltage Regulator<br>LM2941 |
| U0641       | 5183308X01        | Adjustable Voltage Regulator<br>LM2941 |
| U0651       | 5113816A07        | 5V Regulator MC78M05                   |
| U0652       | 5113815A02        | Under Voltage Sensor                   |
| U0653       |                   | not used                               |
| U3101       | 5186144B01        | SA616 IFIC                             |
| U3180       | 5185661L01        | Dual Rail to Rail Opamp                |
| U3201       | 5185963A27        | Low Voltage FracN                      |
| U3202       | 5105739X05        | 5V Regulator MC78M05                   |
| U3301       | 5105750U54        | VCO Buffer IC                          |
| U3302       | 4802245J94        | Resonator                              |
| U3303       | 4802245J94        | Resonator                              |
| U3401       | 5185130C65        | LDMOS Power Amplifier                  |
| U3501       | 5185765B26        | Power Control IC                       |
| U3502       | 5185963A15        | Temperature Sensor                     |
| U3503       | 5109731C21        | Dual Opamp                             |
| VR0151      | 4813830A15        | 5.6V Zener MMBZ5232B                   |
| VR0501      | 4805656W09        | Quad 20V Zener<br>MMQA20VT1            |
| VR0503      | 4805656W09        | Quad 20V Zener<br>MMQA20VT1            |
| VR0504      | 4813830A40        | 33V Zener MMBZ5257B                    |
| VR0505      | 4805656W09        | Quad 20V Zener<br>MMQA20VT1            |
| VR0509      | 4813830A40        | 33V Zener MMBZ5257B                    |
| VR0510      | 4813830A40        | 33V Zener MMBZ5257B                    |
| VR0537      | 4813830A15        | 5.6V Zener MMBZ5232B                   |
| VR0541      | 4813830A27        | 14V Zener                              |
| VR0601      | 4813832C77        | Transient Suppressor                   |
| VR0621      | 4813830A15        | 5.6V Zener MMBZ5232B                   |
| VR0671      |                   | not used                               |
| VR3470      | 4813830A15        | 5.6V Zener MMBZ5232B                   |
| Y0131       | 4880113R19        | Ceramic Resonator 38.4 kHz             |

| Circuit Ref | Motorola Part No. | Description                        |
|-------------|-------------------|------------------------------------|
| Y3101       | 4880606B10        | 72.895 MHz 3rd Overtone<br>Crystal |
| Y3102       | 9186145B02        | 455 kHz Discriminator              |
| Y3201       | 4802245J68        | 16.8 MHz Reference<br>Oscillator   |

\* Motorola Depot Servicing only

Reference designators with an asterisk indicate components which are not field replaceable because they need to be calibrated with specialized factory equipment after installation. Radios in which these parts have been replaced in the field will be off-frequency at temperature extremes.

This page intentionally left blank

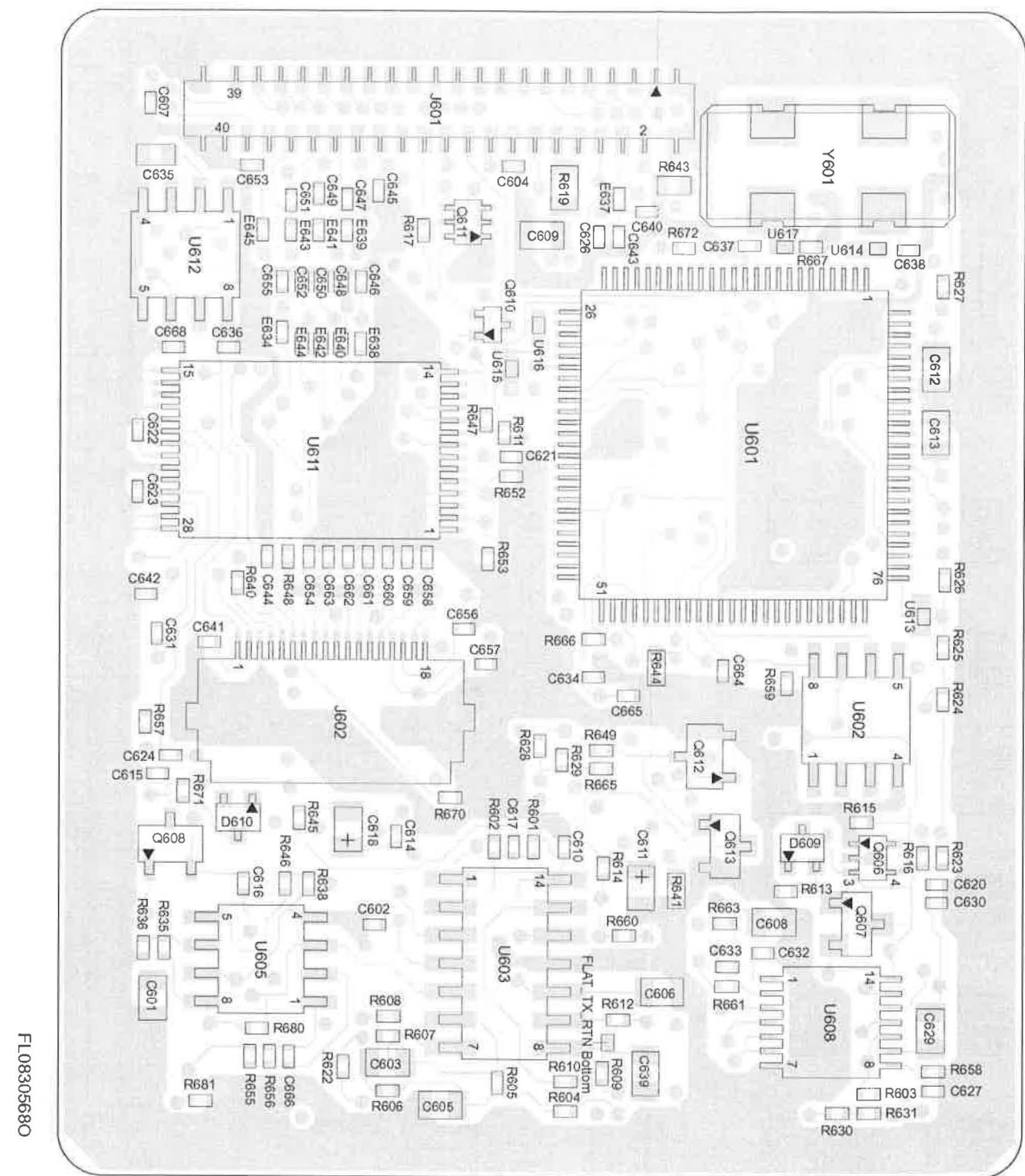
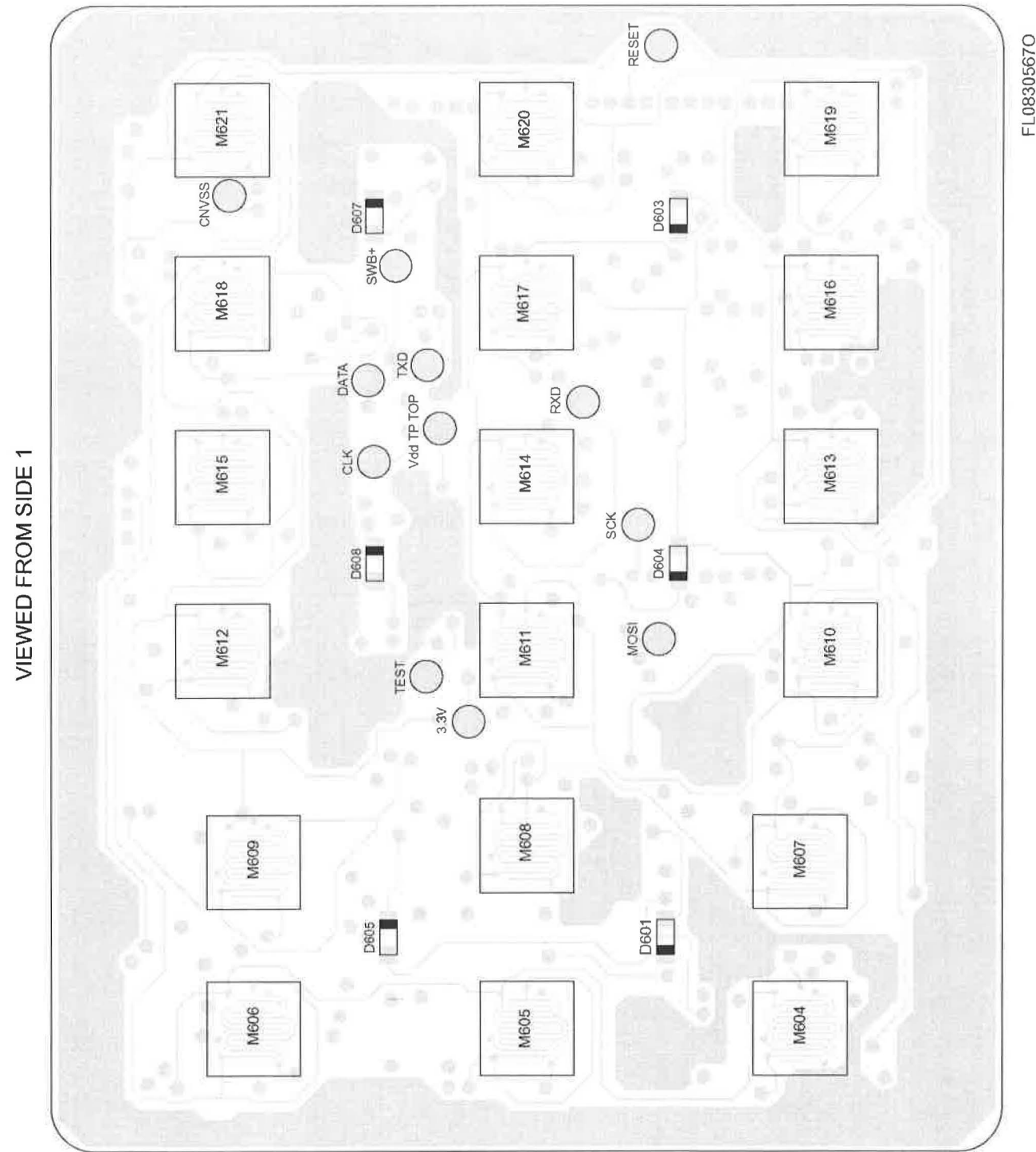

Figure 4-31. PassPort Trunking Controller Board Side 1 & 2

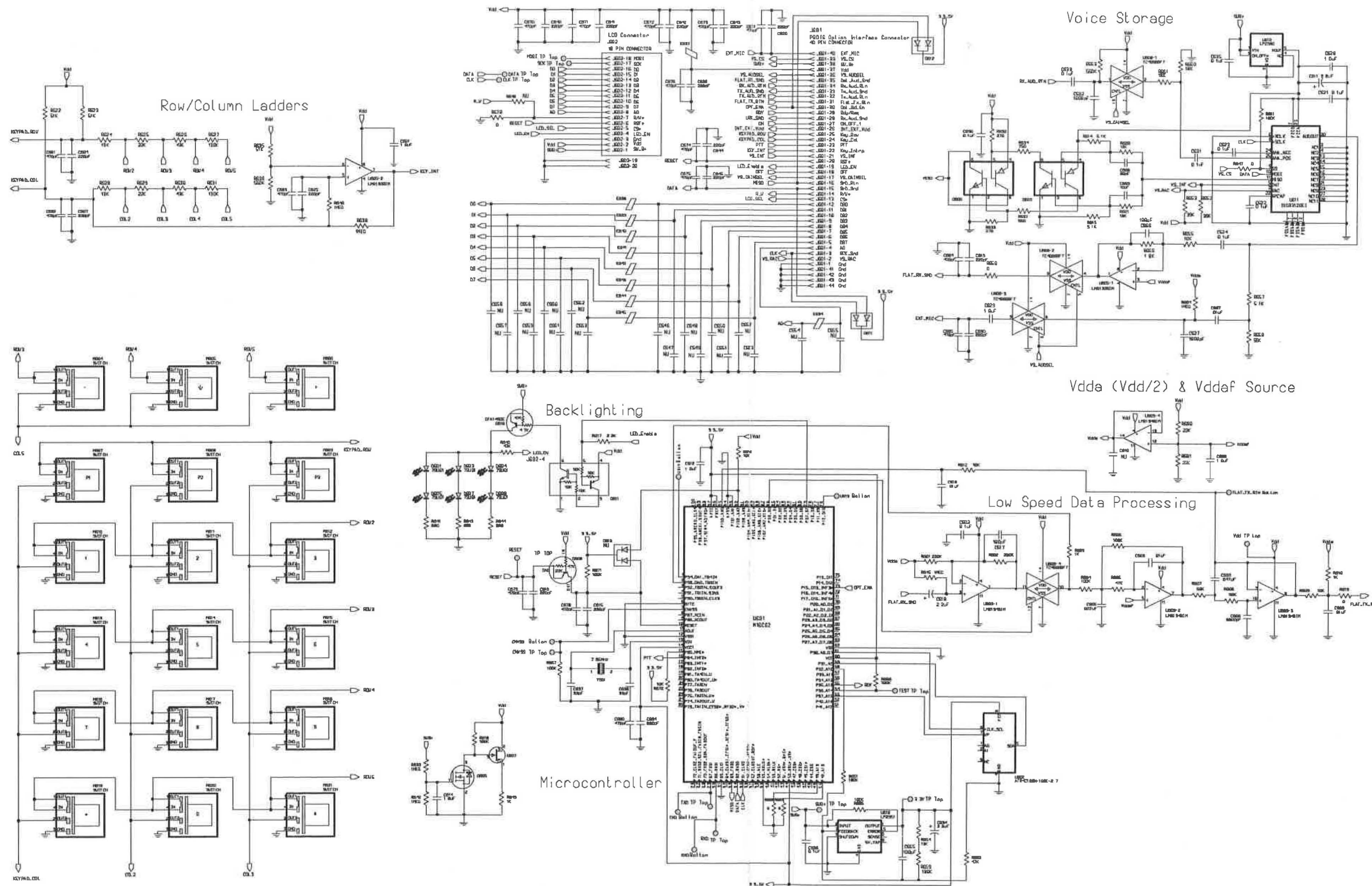

Figure 4-32. PassPort Trunking Controller Board Schematic Diagram







Motorola, The Stylized M logo, Intelligence Everywhere, and Professional Radio are trademarks of Motorola, Inc.  
LTR is a registered trademark of E.F. Johnson Company.  
PassPort is a registered trademark of Trident Datacom Technologies, Inc.  
All other product or service names are the property of their respective owners.  
© 2002 Motorola, Inc. All rights reserved. Printed in U.S.A.



6864110R14-O