

Asterisk (*) denotes parts not placed for the basic model radio (see the logic board parts list).
 Double asterisks (**) denote J750 not placed for GTX radios only.

Schematic Diagram
 for FLN8514A, FLN9053A, FLN9064A, HLN9859, HLN9860, FEN1648, and FEN1656 Logic Board

parts list

FLN8514A Logic Board

REFERENCE SYMBOL	MOTOROLA PART NO.	DESCRIPTION
capacitors: ±5%, 50 V unless otherwise stated		
C406	2113741F49	0.01 µF
C407	2311049A40	2.2 µF
C435	2113743E20	100 nF
C700	2113743E07	22 nF
C700	Not placed in Basic Model Radios.	
C707	2113741F17	470 pF
C708	2113741F49	0.01 µF
C710	2311049J11	4.7 µF
C711	2311049A07	1 µF
C716	2113743F08	0.22 µF
C717	2113743F01	0.1 µF
C718	2113743E20	100 nF
C719	2113743F01	0.1 µF
C720	2113741A45	10 nF
C721	2311049A01	0.1 µF
C733	2113740F41	39 pF
C737	2113740F41	39 pF
C738	2113740F41	39 pF
C741-745	2113740F41	39 pF
C745	Not placed in Basic Model Radios.	
C746, 747	2113740F41	39 pF
C754	2113743E20	100 nF
C758	2113743E20	100 nF
C761	2113740F41	39 pF
C763	2113741F49	0.01 µF
C765	2113743E20	100 nF
C769	2113740F41	39 pF
C777	2311049A07	1 µF
C781	2113743E20	100 nF
C786-787	2113743E20	100 nF
C788	2113743K15	0.1 µF
C789	2113740F41	39 pF
C790	2113741F13	330 pF

diodes: (see note)		
CR707-708	4813833C02	MMBD6100L

LEDs:		
DS701-704	4805729G92	GREEN
DS701-704	Not placed in Basic Model Radios.	

shield:		
E01	2683423K03	423K03

connectors, receptacle:		
J700	0904658J02	edge
J750	0980332L01	edge
J750	Not placed in GTX models.	

transistors: (see note 1)		
Q1	4813824A10	NPN, 3904L
Q1	Not placed in Basic Model Radios.	
Q2	4882033T01	NPN, 1_DTC144YK

resistors: Ω, 5%, 1/16 W unless otherwise stated		
R403	0662057A97	100K
R468	0662057A73	10K
R700	0662057A97	100K
R700	Not placed in Basic Model Radios.	

REFERENCE SYMBOL	MOTOROLA PART NO.	DESCRIPTION
R705	0662057A89	47K
R710	0662057A89	47K
R725	0662057A94	75K
R726	0662057A95	82K
R751	0662057B47	0
R753	0662057A73	10K
R756	0662057A73	10K
R763	0662057A65	4.7K
R764	0662057A73	10K
R790	0662057A81	22K
R792	0662057A73	10K
R793	0662057C55	150
R793	Not placed in Basic Model Radios.	
R794	0662057C55	150
R794	Not placed in Basic Model Radios.	
R795	0662057A85	33K
R797-798	0662057A73	10K
integrated circuits: (see note 1)		
U701	5105835U45	ASFIC_F83-1
U703	5108444S49	X25320
U704	5180633C01	TK11950
U705	5108444S61	E28F020
U706	5108444S67	SRAM 32Kx8
U707	5102463J21	MSM6606
U707	Not placed in Basic Model Radios.	
U709	5102463J20	MC68HC11K1
Zener diodes: (see note 1)		
VR707	4813830A27	MMBZ5244L

FLN9053A Logic Board

REFERENCE SYMBOL	MOTOROLA PART NO.	DESCRIPTION
All parts listed for FLN9053A is identical to those listed for FLN8514A with the following addition:		
integrated circuits: (see note 1)		
U703	5108444S71	8K EEPROM

FLN9064A Logic Board

REFERENCE SYMBOL	MOTOROLA PART NO.	DESCRIPTION
All parts listed for FLN9064A are identical to those listed for FLN8514A with the following addition:		
capacitors: ±5%, 50 V unless otherwise stated		
C716	2113743F12	0.33 µF

Notes:
 1. For optimum performance, diodes, transistors and integrated circuits must be ordered by MOTOROLA part numbers.
 2. When ordering quartz crystal units or ceramic resonators, specify carrier frequency, crystal (or resonator) frequency, and crystal (or resonator) type number.

GTX/GTX LTR Mechanical Parts List

REFERENCE SYMBOL	MOTOROLA PART NO.	DESCRIPTION
1	1580421K01	front housing
2		lens
3	3380425K01	name plate
4	7580437C01	PTT keypad
5	1380159S01	PTT bezel
6	3286074C01	PTT chim
7	3880428C01	dust cap
8	6180968Y01	light pipe
9	3280960Y01	seal, 2 used
10	1386080C01	escutcheon
11	5880636V01	antenna adapter
12	8505241U03	antenna whip
13	3680448K01	frequency knob
14	3680447K01	volume knob
15	3580998Z04	speaker felt
16	3080560D01	speaker/mic cable
17	1480577C01	microphone boot
18	5013920A03	microphone
19	5005589U05	speaker
20	7580506C02	speaker pad
21	3286062C01	speaker chim
22	3980546B02	front-shield ground contact pad
23	7580685K01	pad
24	7580427K01	keypad
25*	8408050Y01	heat-sealed flexible cable
26*	7204616J01	LCD
27	FLN8514A	logic board, assembled (used in FUF1190A)
	FLN9064A	logic board, assembled (used in FUF1198B)
28	6180687K01	reflector
29	2680402K01	logic board shield
30	4105944K01	battery latch spring, 2 used
31	5580438B01	latch
32	4280190R04	shield clip, 4 used
33	2680532C01	front shield
34	8408051Y01	RF-to-Logic flexible circuit
35	FUF5591A	RF board, assembled
36	3286063C01	O-ring gasket
37	1480610B01	chassis insulator
38	2780549B01	chassis
39	3286213C01	handie talkie label
40	5480673K02	FCC label
41	3980188R01	contact, B+/B-
42	FLN8517A	battery filter board, assembled
43	3202386L03	shield RFI
44	HNN9628	battery
45	HLN9724/ HLN8255	standard belt clip

* Not field repairable

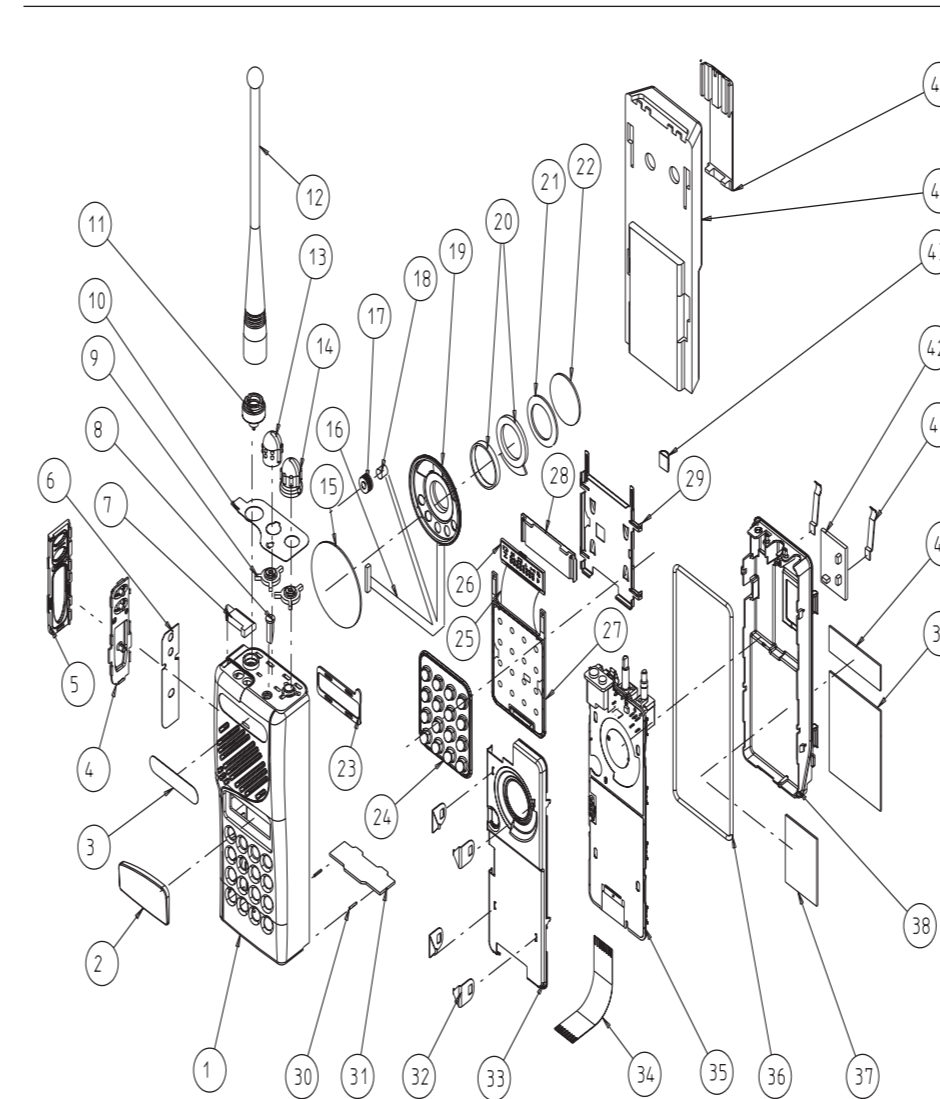

GTX Exploded View

GTX/GTX LTR Basic Model Mechanical Parts List

REFERENCE SYMBOL	MOTOROLA PART NO.	DESCRIPTION
1	1580638V01	front housing
2	3380637V01	label, front
3	3380425K01	name plate
4	7580437C01	PTT keypad
5	1380159S01	PTT bezel
6	3880428C01	dust cap
7	6180968Y01	light pipe
8	3280960Y01	seal, 2 used
9	1380507B03	escutcheon
10	5880376L01	antenna adapter
11	8505241U04	antenna whip
12	3680448K01	frequency knob
13	3680447K01	volume knob
14	3580998Z04	speaker felt
15	3080560D01	speaker/mic cable
16	1480577C01	microphone boot
17	5013920A03	microphone
18	5005589U05	speaker
19	7580506C02	speaker pad
20	3286062C01	speaker chim
21	3980546B02	front-shield ground contact pad
22	FLN8836A	logic board, assembled
23	2680402K01	battery latch spring, 2 used
24	4105944K01	latch
25	5580438B01	shield clip, 4 used
26	4280190R04	front shield
27	2680532C01	RF-to-Logic flexible circuit
28	8408051Y01	RF board, assembled
29	FUF5691A	O-ring gasket
30	3280545C01	chassis insulator
31	1480610B01	chassis
32	2780549B01	FCC label
33	5480673K02	contact, B+/B-
34	3980188R01	battery filter board, assembled
35	FLN8517A	shield RFI
36	3202386L03	battery
37	HNN9628	battery
38	HLN9724/ HLN8255	standard belt clip

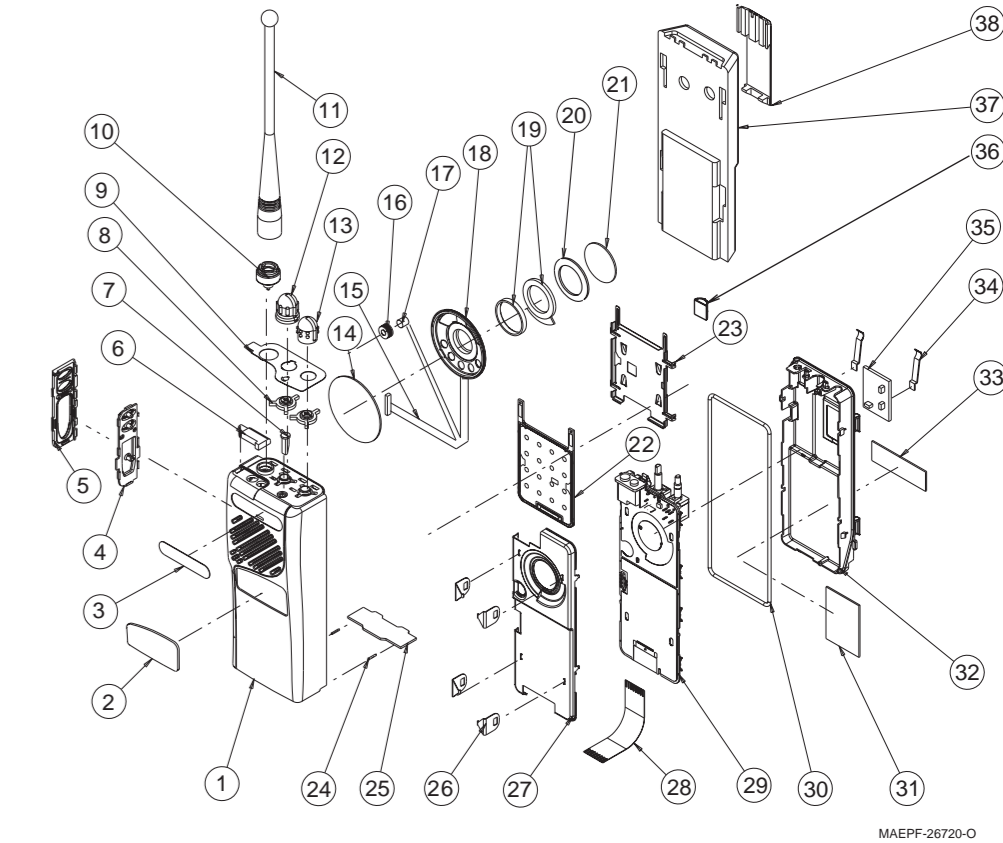

GTX Basic Model Radio Exploded View

LTS 2000 Mechanical Parts List

REFERENCE SYMBOL	MOTOROLA PART NO.	DESCRIPTION
1	1580422K02	front housing
2	-----LENS	cannot be ordered separately
3	3380455K01	name plate
4	7580430K01	PTT keypad
5	1380431K01	PTT bezel
6	3286074C01	PTT chim
7	3880428C01	dust cap
8	6180968Y01	light pipe
9	3280960Y01	seal, 2 used
10	1380463K01	escutcheon (8 positions) (used in FUF1192A and FUF1493A)
	1380463K02	escutcheon (16 positions) (used in FUF1492A)
11	5880636V01	antenna adapter
12	8505241U03	antenna whip
13	3680433K01	frequency knob (8 positions) (used in FUF1192A and FUF1493A)
	3680433K02	frequency knob (16 positions) (used in FUF1492A)
14	3680432K01	volume knob
15	3580998Z04	speaker felt
16	3080560D01	speaker/mic cable
17	1480577C01	microphone boot
18	5013920A03	microphone
19	5005589U05	speaker
20	7580506C02	speaker pad
21	3286062C01	speaker chim
22	3980546B02	front-shield ground contact
23	7580685K01	pad
24	7580428K02	keypad
25*	8408050Y01	heat-sealed flexible cable
26*	7204616J01	LCD
27	FLN8514A	logic board, assembled (used in FUF1192A)
	FLN9053A	logic board, assembled (used in FUF1492A and FUF1493A)
28	6180687K01	reflector
29	2680402K01	logic board shield
30	4105944K01	battery latch spring, 2 used
31	5580438B01	latch
32	4280190R04	shield clip, 4 used
33	2680532C01	front shield
34	8408051Y01	RF-to-logic flexible circuit
35	FUF5590A	RF board, assembled (used in FUF1192A, FUF1492A, and FUF1493A)
36	3286063C01	O-ring gasket
37	1480610B01	chassis insulator
38	2780549B01	chassis
39	3286213C01	handie talkie label
40	5480673K02	FCC label
41	3986132F01	contact, B+/B-
42	FLN8517A	battery filter board
43	3202386L03	shield RFI
44	HNN9628	battery
45	HLN9724/ HLN8255	standard belt clip

* Not field repairable

* Not field repairable

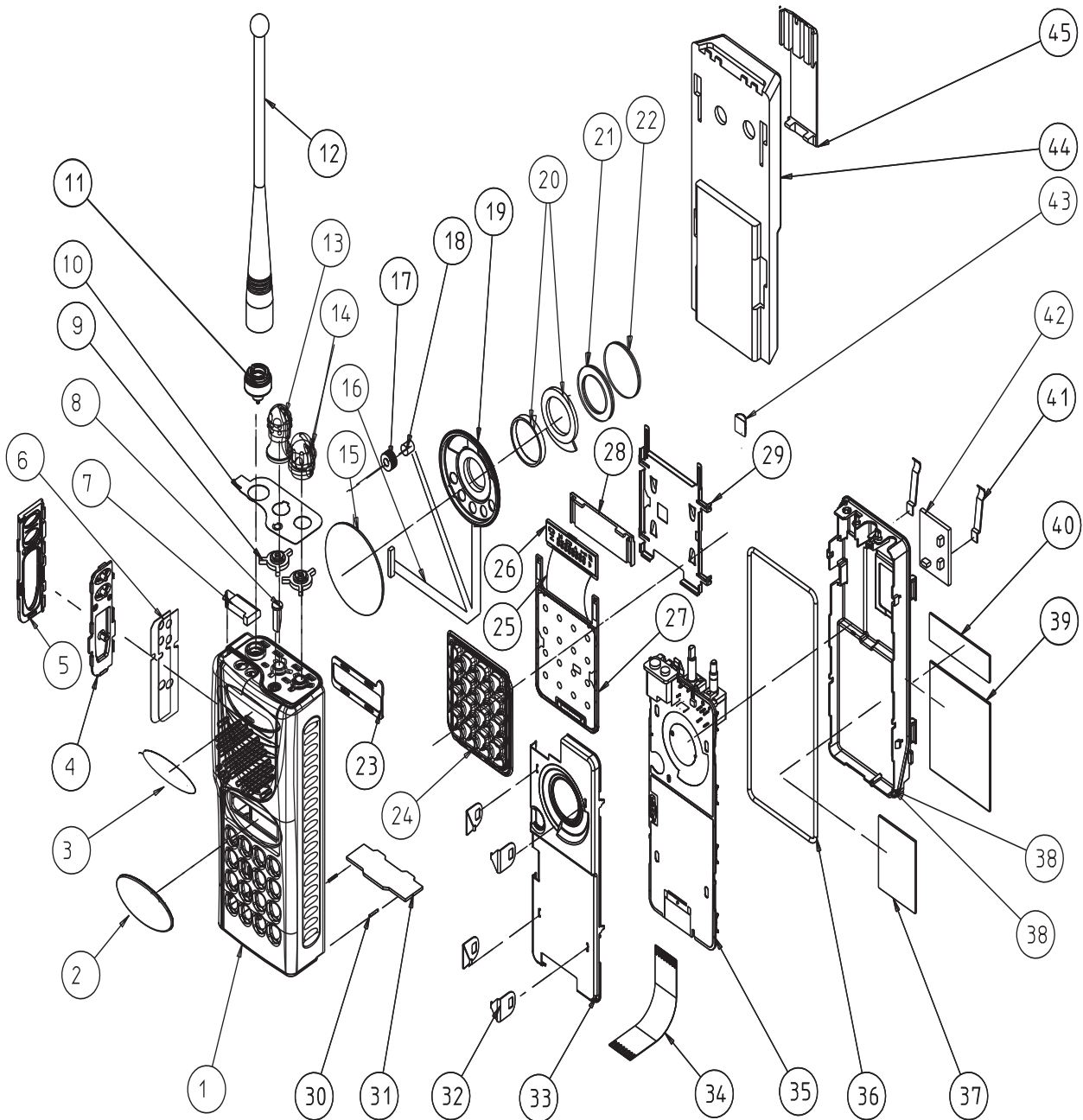

LTS 2000 Exploded View

Miscellaneous Parts Lists

FHN5873A Housing (GTX/GTX LTR)

REFERENCE SYMBOL	MOTOROLA PART NO.	DESCRIPTION
Qty	non-referenced items:	
1	1380159S01	PTT bezel
1	1386080C01	escutcheon
1	1580421K01	housing
2	3280960Y01	seal
1	3286074C01	PTT chim
1	3380425K01	logo
1	3580998Z04	speaker felt
1	3880428C01	dust cap
2	4105944K01	battery latch spring
1	5580438B01	latch
1	5880376L01	adapter antenna
1	6180968Y01	light pipe led
1	7580437C01	PTT keypad

FHN5874A Housing (LTS 2000)

REFERENCE SYMBOL	MOTOROLA PART NO.	DESCRIPTION
Qty	non-referenced items:	
1	1380431K01	PTT bezel
1	1380463K01	top esc
1	1580422K02	housing
1	3280960Y01	seal
1	3286074C01	PTT chim
1	3380455K01	logo
1	3580998Z04	speaker felt
1	3880428C01	dust cap
2	4105944K01	battery latch spring
1	5580438B01	latch
1	5880376L01	adapter antenna
1	6180968Y01	light pipe led
1	7580430K01	PTT keypad

FHN5978A Housing (LTS 2000 SmartZone)

REFERENCE SYMBOL	MOTOROLA PART NO.	DESCRIPTION
Qty	non-referenced items:	
1	1380431K01	PTT bezel
1	1380463K02	top escutcheon 16 pos.
1	1580422K02	housing, front hsng
2	3280960Y01	seal vol
1	3286074C01	PTT chim
1	3380455K01	logo
1	3580998Z04	speaker felt
1	3880428C01	dust cap
2	4105944K01	battery latch spring
1	5580438B01	latch
1	5880376L01	adapter antenna
1	6180968Y01	light pipe led
1	7580430K01	PTT keypad

Miscellaneous Parts Lists (cont.)

FLN8574A Housing Miscellaneous Parts (GTX/GTX LTR)

REFERENCE SYMBOL	MOTOROLA PART NO.	DESCRIPTION
Qty non-referenced items:		
1	2680402K01	logic board shield
0.2	3202386L03	RFI shield
1	6180687K01	LCD light reflector
1	7580427K01	main keypad
1	7580685K01	pad

FLN8576A Housing Miscellaneous Parts (LTS 2000)

REFERENCE SYMBOL	MOTOROLA PART NO.	DESCRIPTION
Qty non-referenced items:		
1	2680402K01	logic board shield
0.2	3202386L03	RFI shield
1	6180687K01	LCD light reflector
1	7580428K02	main keypad
1	7580685K01	pad

FLN8575A Shield & Parts

REFERENCE SYMBOL	MOTOROLA PART NO.	DESCRIPTION
Qty non-referenced items:		
1	2680532C01	front shield
4	4280190R04	shield clip

FLN8577A Miscellaneous Parts (GTX/GTX LTR)

REFERENCE SYMBOL	MOTOROLA PART NO.	DESCRIPTION
Qty non-referenced items:		
1	3286063C01	O-ring, gasket
1	3380184R01	FCC label
1	3680447K01	volume knob
1	3680448K01	frequency knob
1	8408051Y01	rf-to-logic flexible circuit

FLN8665A Miscellaneous Parts (LTS 2000)

REFERENCE SYMBOL	MOTOROLA PART NO.	DESCRIPTION
Qty non-referenced items:		
1	3286063C01	O-ring, gasket
1	3380184R01	FCC label
1	3680432K01	volume knob
1	3680433K01	frequency knob
1	8408051Y01	rf-to-logic flexible circuit

FLN8665B Miscellaneous Parts (LTS 2000 SmartZone)

REFERENCE SYMBOL	MOTOROLA PART NO.	DESCRIPTION
Qty non-referenced items:		
1	3286063C01	O-ring gasket
1	3380184R01	FCC label
1	3680432K01	volume knob
1	3680433K02	frequency knob 16 pos.
1	8408051Y01	rf-to-logic flexible circuit

FSN5509A Speaker & Microphone Assembly

REFERENCE SYMBOL	MOTOROLA PART NO.	DESCRIPTION
Qty non-referenced items:		
1	1480577C01	microphone boot
1	2113740F41	chip capacitor, 39 μ F \pm 5% 50V
1	3080560D01	speaker mic cable
1	3286062C01	speaker chim
1	3980546B01	front shield ground contact
1	5005589U05	speaker
1	5013920A03	microphone
1	7580506C02	speaker pad

NAF5037A Antenna

REFERENCE SYMBOL	MOTOROLA PART NO.	DESCRIPTION
Qty non-referenced item:		
1	8505241U03	whip antenna, 800 MHz

SERVICE MANUAL QUESTIONNAIRE

We believe that reports from users provide valuable information for producing quality manuals. By taking a few moments to answer the following questions as they relate to this specific manual, you can take an active role in the continuing effort to ensure that our manuals contain the most accurate and complete information of benefit to you. Thank you for your cooperation.

In reference to Manual Number: 68P02945C75-A

GTX/GTX LTR/LTS 2000™ Portable Radio

1. Please check all the appropriate boxes:

	Complete	Incomplete	Correct	Incorrect	Clear	Confusing	Size Adequate	Size Too Small	Not Covered in This Manual
Disassembly Procedures									
Alignment Procedures									
Exploded Views									
Schematic Diagrams									
Circuit Board Details									
Electrical Parts Lists									
Exploded View Parts List									

2. How would you rate the overall organization of this manual?

excellent
 very good
 good
 fair
 poor

3. Did this Service manual provide you with the information necessary to service and maintain the specific equipment?

very much so
 generally yes
 to some extent
 no

4. How do you rate this particular Service Manual?

excellent
 very good
 good
 fair
 poor

5. We would appreciate any corrections or recommendations for improving this manual. Please include the specific page number(s) of the diagram or procedure in question.

a. Disassembly Procedures:(Page No. _____)

b. Alignment Procedures:(Page No. _____)

c. Exploded Views:(Page No. _____)

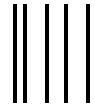

NO POSTAGE
NECESSARY
IF MAILED
IN THE
UNITED STATES



BUSINESS REPLY MAIL
FIRST CLASS MAIL PERMIT NO 9040 FT. LAUDERDALE, FL

POSTAGE WILL BE PAID BY ADDRESSEE



MOTOROLA

Attention: Technical Communications
8000 W. Sunrise Boulevard
Ft. Lauderdale, FL 33322



FOLD

FOLD

(Continued)

Please specify the page number along with any corrections or recommendations for improvement.

- d. Schematic Diagrams: (Page No. _____)
- e. Component Location Details: (Page No. _____)
- f. Electrical Parts List: (Page No. _____)
- g. Exploded View Parts List: (Page No. _____)

6. General comments/suggestions:

Name:.....

Company:.....

Customer COSC MSS FTR Other

Address:

City/State/Zip:.....

Phone Number (Please include Area Code):

PLEASE USE TAPE TO SEAL

POSTAL REGULATIONS PROHIBIT USE OF STAPLES