

**QUANTAR**<sup>TM</sup>**Digital – Capable Station**

For Conventional, *SECURENET*, *ASTRO*,  
6809 Trunking, and *IntelliRepeater* Systems

VHF — 25W & 125W  
UHF — 25W, 100W, & 110W  
800 MHz — 20W & 100W  
900 MHz — 100W



THIS MANUAL HAS BEEN  
**DISCONTINUED**

**Instruction Manual**

68P81095E05 – B /D



## Table of Contents

Model/Option Information .....	xi
Foreword .....	xxiv
General Safety Information .....	xxvi
Performance Specifications .....	xxviii
<b>DESCRIPTION .....</b>	<b>68P81096E56</b>
<b>Introduction .....</b>	<b>page 1</b>
Compact Mechanical Design .....	page 1
State-of-the-Art Electrical Design .....	page 2
Summary of Operating Features .....	page 3
Multiple System Capability .....	page 4
<b>Station Components .....</b>	<b>page 6</b>
<b>Functional Theory of Operation .....</b>	<b>page 8</b>
Transmitter Circuitry Operation .....	page 5
Receiver Circuitry Operation .....	page 9
Station Control Circuitry Operation .....	page 9
Wireline Interface Board Operation .....	page 10
Power Supply Module Operation .....	page 10
<b>INSTALLATION .....</b>	<b>68P81096E57</b>
<b>Pre-Installation Considerations .....</b>	<b>page 2</b>
Installation Overview .....	page 2
Environmental Conditions at Intended Site .....	page 3
Equipment Ventilation .....	page 3
AC Input Power Requirements .....	page 4
Equipment Mounting Methods .....	page 4
Site Grounding and Lightning Protection .....	page 5
Recommended Tools and Equipment .....	page 6
Equipment Unpacking and Inspection .....	page 6
Physical Dimensions and Clearances .....	page 7
<b>Mechanical Installation .....</b>	<b>page 14</b>
Unpacking the Equipment .....	page 14
Mounting Procedures .....	page 20
Stacking Cabinets .....	page 25
Stacking Modular Racks .....	page 26
Anti-Vibration/EMI Screws .....	page 27

<b>Electrical Connections</b> .....	<b>page 28</b>
Power Supply Connections .....	page 28
RF Cabling Connections .....	page 32
Connecting System Cables .....	page 38
Connecting Telephone Lines .....	page 46
Connecting V24 Modems .....	page 50
Connecting External Reference .....	page 51
<b>Post-Installation Checkout</b> .....	<b>page 54</b>
Applying Power .....	page 54
Verifying Proper Operation .....	page 54
Proceeding to Optimization .....	page 56

**OPTIMIZATION** ..... **68P81086E72**

<b>Description</b> .....	<b>page 1</b>
--------------------------	---------------

**OPERATION** ..... **68P81096E58**

<b>Description</b> .....	<b>page 1</b>
Summary of Switches, Pushbuttons, and Connectors .....	page 1
Summary of LED Indicators .....	page 1

## **Maintenance & Troubleshooting**

**ROUTINE MAINTENANCE** ..... **68P81086E39**

<b>Introduction</b> .....	<b>page 1</b>
<b>Recommended Test Equipment</b> .....	<b>page 1</b>

**TROUBLESHOOTING** ..... **68P81096E59**

<b>Introduction</b> .....	<b>page 1</b>
<b>Recommended Test Equipment</b> .....	<b>page 1</b>
<b>Troubleshooting Procedures</b> .....	<b>page 2</b>
Troubleshooting Overview .....	page 2
Interpreting LED Indicators .....	page 6
Interpreting Alarm Alert Tones .....	page 9
Verifying Transmitter Circuitry .....	page 10
Verifying Receiver Circuitry .....	page 14

**Module Replacement Procedures** .....

General Replacement Information .....	<b>page 19</b>
Replacing Power Amplifier Module .....	page 21
Replacing Exciter Module .....	page 22
Replacing Power Supply Module .....	page 23
Replacing Station Control Module .....	page 24
Replacing Wireline Interface Board .....	page 30
Replacing Receiver Module and/or Preselector Assembly (VHF and UHF) .....	page 32
Replacing Receiver Module (800 MHz and 900 MHz) .....	page 33
Replacing ASTRO Modem Card .....	page 34
Replacing Backplane Board .....	page 35

<b>Preselector Field Tuning Procedure</b> .....	<b>page 36</b>
Required Test Equipment .....	page 36
VHF Tuning Procedure .....	page 37
UHF Tuning Procedure .....	page 40

## Station Modules

### RECEIVER CIRCUITRY

<b>RECEIVER MODULE (VHF RANGES 1 AND 2; INCLUDES PRESELECTOR)</b> .....	<b>68P81086E28</b>
---	--------------------

<b>Description</b> .....	<b>page 1</b>
General Description .....	page 1
Overview of Circuitry .....	page 1
<b>Controls, Indicators, and Inputs/Outputs</b> .....	<b>page 2</b>
<b>Functional Theory of Operation</b> .....	<b>page 3</b>
Synthesizer and VCO Circuitry .....	page 3
Preselector Filter Assembly .....	page 4
Receiver Front End Circuitry .....	page 4
Custom Receiver IC Circuitry .....	page 4
Address Decode and A/D Converter Circuitry .....	page 5
Voltage Regulator Circuitry .....	page 5

<b>RECEIVER MODULE (UHF)</b> .....	<b>68P81086E48</b>
------------------------------------	--------------------

<b>Description</b> .....	<b>page 1</b>
General Description .....	page 1
Overview of Circuitry .....	page 1
<b>Controls, Indicators, and Inputs/Outputs</b> .....	<b>page 2</b>
<b>Functional Theory of Operation</b> .....	<b>page 3</b>
Synthesizer and VCO Circuitry .....	page 3
Preselector Filter Assembly .....	page 4
Receiver Front End Circuitry .....	page 4
Custom Receiver IC Circuitry .....	page 4
Address Decode and A/D Converter Circuitry .....	page 5
Voltage Regulator Circuitry .....	page 5

<b>RECEIVER MODULE (800 MHz)</b> .....	<b>68P81086E76</b>
--	--------------------

<b>Description</b> .....	<b>page 1</b>
General Description .....	page 1
Overview of Circuitry .....	page 1
<b>Controls, Indicators, and Inputs/Outputs</b> .....	<b>page 2</b>
<b>Functional Theory of Operation</b> .....	<b>page 3</b>
Synthesizer and VCO Circuitry .....	page 3
Receiver Front End Circuitry .....	page 4
Custom Receiver IC Circuitry .....	page 4
Address Decode and A/D Converter Circuitry .....	page 5
Voltage Regulator Circuitry .....	page 5

---

**RECEIVER MODULE (900 MHz) ..... 68P81091E92**

**Description ..... page 1**

General Description ..... page 1

Overview of Circuitry ..... page 1

**Controls, Indicators, and Inputs/Outputs ..... page 2**

**Functional Theory of Operation ..... page 3**

Synthesizer and VCO Circuitry ..... page 3

Receiver Front End Circuitry ..... page 4

Custom Receiver IC Circuitry ..... page 4

Address Decode and A/D Converter Circuitry ..... page 5

Voltage Regulator Circuitry ..... page 5

**TRANSMITTER CIRCUITRY**

**EXCITER BOARD (VHF, UHF, 800/900 MHz) ..... 68P81086E24**

**Description ..... page 1**

General Description ..... page 1

Overview of Circuitry ..... page 1

**Controls, Indicators, and Inputs/Outputs ..... page 2**

**Functional Theory of Operation ..... page 3**

Synthesizer and VCO Circuitry ..... page 3

RF Switch Circuitry ..... page 4

Microprocessor Circuitry ..... page 4

TX Power Control Circuitry ..... page 5

**VHF POWER AMPLIFIER MODULE (25W/125W R1 & R2) ..... 68P81086E23**

**Description ..... page 1**

General Description ..... page 1

Overview of Circuitry ..... page 1

**Controls, Indicators, and Inputs/Outputs ..... page 2**

**Functional Theory of Operation ..... page 3**

RF Signal Path ..... page 3

Output Power Control ..... page 3

Sense and Detect Circuitry ..... page 4

Cooling Fans Control Circuitry ..... page 6

**UHF POWER AMPLIFIER MODULE (R0/110W; R1 & R2/25W; R1-3/110W; R4/100W) ..... 68P81088E44**

**Description ..... page 1**

General Description ..... page 1

Overview of Circuitry ..... page 1

**Controls, Indicators, and Inputs/Outputs ..... page 2**

**Functional Theory of Operation ..... page 3**

RF Signal Path ..... page 3

Output Power Control ..... page 3

Sense and Detect Circuitry ..... page 4

Cooling Fans Control Circuitry ..... page 6

---

**POWER AMPLIFIER MODULE (20W/100W 800 MHZ; 100W 900 MHZ;) 68P81091E91**

**Description . . . . . page 1**  
    General Description . . . . . Page 1  
    Overview of Circuitry . . . . . page 1

**Controls, Indicators, and Inputs/Outputs . . . . . page 2**

**Functional Theory of Operation . . . . . page 3**  
    RF Signal Path. . . . . Page 3  
    Output Power Control . . . . . Page 3  
    Sense and Detect Circuitry . . . . . page 4  
    Cooling Fans Control Circuitry . . . . . page 6

**Station Control Circuitry**

**STATION CONTROL MODULE (CLN6960/CLN6961) . . . . . 68P81094E76**

**Description . . . . . page 1**  
    General Description . . . . . page 1  
    Overview of Circuitry . . . . . page 2

**Controls, Indicators, and Inputs/Outputs . . . . . page 3**

**Functional Theory of Operation . . . . . page 4**  
    Host Microprocessor/Host ASIC Circuitry . . . . . page 4  
    Non-Volatile Memory . . . . . page 5  
    DRAM Memory . . . . . page 5  
    External Line Interface Circuitry . . . . . page 6  
    Digital Signal Processor (DSP) and DSP ASIC Circuitry . . . . . page 7  
    Station Reference Circuitry . . . . . page 8  
    HDLC Bus Control Circuitry . . . . . page 8  
    Audio Interface Circuitry . . . . . page 9  
    Input/Output Ports . . . . . page 10  
    6809/MRTI Interface Circuitry . . . . . page 10  
    Front Panel LEDs and Switches . . . . . page 11  
    Supply Voltages Circuitry . . . . . page 11

**STATION CONTROL MODULE (CLN1614) . . . . . 68P81096E87**

**Description . . . . . page 1**  
    General Description . . . . . page 1  
    Overview of Circuitry . . . . . page 2

**Controls, Indicators, and Inputs/Outputs . . . . . page 4**

**Functional Theory of Operation (CLN7060A Control Board) . . . . . page 6**  
    Host Microprocessor/Host ASIC Circuitry . . . . . page 6  
    Non-Volatile Memory . . . . . page 7  
    DRAM Memory . . . . . page 7  
    External Line Interface Circuitry . . . . . page 8  
    Digital Signal Processor (DSP) and DSP ASIC Circuitry . . . . . page 9  
    Station Reference Circuitry . . . . . page 10  
    HDLC Bus Control Circuitry . . . . . page 10  
    Audio Interface Circuitry . . . . . page 11  
    Input/Output Ports . . . . . page 12  
    6809/MRTI Interface Circuitry . . . . . page 12

---

Supply Voltages Circuitry .....	page 13
<b>Functional Theory of Operation (CLN7098A LED Board) .....</b>	<b>page 14</b>
Front Panel LEDs and Switches .....	page 14
Front Panel Connectors .....	page 14
<b>STATION CONTROL MODULE (CLN7692) .....</b>	<b>68P81012Y01</b>
<b>Description .....</b>	<b>page 1</b>
General Description .....	page 1
Overview of Circuitry .....	page 1
<b>Controls, Indicators, and Inputs/Outputs .....</b>	<b>page 2</b>
<b>Functional Theory of Operation .....</b>	<b>page 4</b>
Host Microprocessor/Host ASIC Circuitry .....	page 4
Non-Volatile Memory .....	page 5
SDRAM Memory .....	page 5
External Line Interface Circuitry .....	page 5
Digital Signal Processor (DSP) and DSP ASIC Circuitry .....	page 6
Station Reference Circuitry .....	page 8
HDLC Bus Control Circuitry .....	page 9
Audio Interface Circuitry .....	page 9
Input/Output Ports .....	page 10
6809/MRTI Interface Circuitry .....	page 11
Front Panel LEDs and Switches .....	page 11
Supply Voltages Circuitry .....	page 14

## Wireline Circuitry

<b>WIRELINE INTERFACE BOARD (4-WIRE) .....</b>	<b>68P81094E77</b>
<b>Description .....</b>	<b>page 1</b>
General Description .....	page 1
Overview of Circuitry .....	page 1
<b>Controls, Indicators, and Inputs/Outputs .....</b>	<b>page 2</b>
<b>Functional Theory of Operation .....</b>	<b>page 3</b>
Functional Overview .....	page 3
Description of Audio/Data Signal Paths .....	page 7
<b>WIRELINE INTERFACE MODULE (8-WIRE) .....</b>	<b>68P81094E78</b>
<b>Description .....</b>	<b>page 1</b>
General Description .....	page 1
Overview of Circuitry .....	page 1
<b>Controls, Indicators, and Inputs/Outputs .....</b>	<b>page 2</b>
<b>Functional Theory of Operation .....</b>	<b>page 3</b>
Functional Overview .....	page 3
Description of Audio/Data Signal Paths .....	page 7

---

# Station Backplane

## STATION BACKPLANE BOARD

<b>Description</b> .....	<b>page 1</b>
<b>Location of Backplane Connectors</b> .....	<b>page 2</b>
<b>Backplane Connectors Information</b> .....	<b>page 3</b>

## Station Power Supply Modules

### 265W POWER SUPPLY MODULE (AC INPUT) ..... 68P81096E09

<b>Description</b> .....	<b>page 1</b>
General Description .....	page 1
Power Supply Module Simplified Block Diagram .....	page 2
Overview of Circuitry .....	page 3
<b>Performance Specifications</b> .....	<b>page 6</b>
<b>Controls, Indicators, and Inputs/Outputs</b> .....	<b>page 7</b>
<b>Functional Theory of Operation (AC-to-DC Converter Board)</b> .....	<b>page 8</b>
Input Conditioning Circuitry .....	page 8
Startup Delay Circuitry .....	page 8
Boost/Power Factor Correction Circuitry .....	page 9
Battery Revert Trigger Circuitry .....	page 9
VCC Supply Circuitry .....	page 9
LED Status Indicators .....	page 10
<b>Functional Theory of Operation (DC-to-DC Converter Board)</b> .....	<b>page 11</b>
+14V Main Supply Circuitry .....	page 11
+5V Supply Circuitry .....	page 12
Battery Charger Control Circuitry .....	page 12
Reference Voltage Circuitry .....	page 12
Diagnostics Circuitry .....	page 13
Address Decode Circuitry .....	page 13
Startup/Shutdown Control Circuitry .....	page 14
<b>Functional Theory of Operation (Battery Charger/Revert Board)</b> .....	<b>page 15</b>
Charger Supply Circuitry .....	page 15
Pulse Width Modulator Circuitry .....	page 16
Battery Revert Circuitry .....	page 16
Current Mode Controller Circuitry .....	page 16
SPI Bus Interface Circuitry .....	page 17
Shutdown Circuitry .....	page 17
Local Supplies Circuitry .....	page 17



---

<b>625W POWER SUPPLY MODULE (ac input)</b> .....	<b>68P81095E88</b>
<b>Description</b> .....	<b>page 1</b>
<b>Performance Specifications</b> .....	<b>page 6</b>
<b>Controls, Indicators, and Inputs/Outputs</b> .....	<b>page 7</b>
<b>Functional Theory of Operation (AC-to-DC Converter Board)</b> .....	<b>page 8</b>
Input Conditioning Circuitry .....	page 8
Startup Delay Circuitry .....	page 8
Boost/Power Factor Correction Circuitry .....	page 9
Battery Revert Trigger Circuitry .....	page 9
VCC Supply Circuitry .....	page 9
LED Status Indicators .....	page 10
<b>Functional Theory of Operation (DC-to-DC Converter Board)</b> .....	<b>page 11</b>
+28V Main Supply Circuitry .....	page 11
+14V Supply Circuitry .....	page 12
+5V Supply Circuitry .....	page 12
Battery Charger Control Circuitry .....	page 13
Reference Voltage Circuitry .....	page 13
Diagnostics Circuitry .....	page 13
Address Decode Circuitry .....	page 14
Startup/Shutdown Control Circuitry .....	page 14
<b>Functional Theory of Operation (Battery Charger/Revert Board)</b> .....	<b>page 15</b>
Charger Supply Circuitry .....	page 15
Pulse Width Modulator Circuitry .....	page 16
Battery Revert Circuitry .....	page 16
Current Mode Controller Circuitry .....	page 16
SPI Bus Interface Circuitry .....	page 17
Shutdown Circuitry .....	page 17
Local Supplies Circuitry .....	page 17
<b>210W POWER SUPPLY MODULE (12/24 AND 48/60 V DC INPUT)</b> .....	<b>68P81085E12</b>
<b>Description</b> .....	<b>page 1</b>
General Description .....	page 1
Overview of Circuitry .....	page 2
<b>Performance Specifications</b> .....	<b>page 3</b>
<b>Controls, Indicators, and Inputs/Outputs</b> .....	<b>page 4</b>
<b>Functional Theory of Operation</b> .....	<b>page 5</b>
Input Conditioning Circuitry .....	page 5
Startup Inverter Circuitry .....	page 6
Main Inverter Circuitry .....	page 6
+5V Inverter Circuitry .....	page 7
Diagnostics Circuitry .....	page 8
Address Decode Circuitry .....	page 8

---

<b>600W POWER SUPPLY MODULE (24 V DC INPUT)</b> .....	<b>68P81090E44</b>
<b>Description</b> .....	<b>page 1</b>
<b>Performance Specifications</b> .....	<b>page 3</b>
<b>Controls, Indicators, and Inputs/Outputs</b> .....	<b>page 4</b>
<b>Functional Theory of Operation</b> .....	<b>page 5</b>
Input Conditioning Circuitry .....	page 5
Startup Inverter Circuitry .....	page 6
Main Inverter Circuitry .....	page 6
14.2 V Inverter Circuitry .....	page 7
+5 V Inverter Circuitry .....	page 7
Diagnostics Circuitry .....	page 8
Address Decode Circuitry .....	page 8

<b>600W POWER SUPPLY MODULE (48/60 V DC INPUT)</b> .....	<b>68P81096E84</b>
<b>Description</b> .....	<b>page 1</b>
General Description .....	page 1
Power Supply Module Simplified Block Diagram .....	page 2
Overview of Circuitry .....	page 3
<b>Performance Specifications</b> .....	<b>page 4</b>
<b>Controls, Indicators, and Inputs/Outputs</b> .....	<b>page 5</b>
<b>Functional Theory of Operation (DC Input Board)</b> .....	<b>page 6</b>
Input Conditioning Circuitry .....	page 6
Inverter Circuitry A and B .....	page 7
Output Filter Circuitry .....	page 7
<b>Functional Theory of Operation (DC Output Board)</b> .....	<b>page 8</b>
Inverters A/B Control Circuitry .....	page 8
+14.2 V Supply Circuitry .....	page 9
+5V Supply Circuitry .....	page 9
Reference Voltage Circuitry .....	page 9
Diagnostics Circuitry .....	page 10
Address Decode Circuitry .....	page 10
Startup/Shutdown Control Circuitry .....	page 11

## Ancillary Equipment

<b>ANTENNA RELAY (OPTION X371AA)</b> .....	<b>68P81086E22</b>
<b>Description</b> .....	<b>page 1</b>
<b>Input and Output Connections</b> .....	<b>page 2</b>
<b>Option Complement</b> .....	<b>page 3</b>
<b>Performance Specifications</b> .....	<b>page 3</b>
<b>Mounting Locations</b> .....	<b>page 4</b>
<b>Functional Theory of Operation</b> .....	<b>page 5</b>

---

## TRIPLE CIRCULATOR OPTIONS

<b>VHF TRIPLE CIRCULATOR OPTION (OPTIONS X676AA-AC)</b> .....	<b>68P81086E34</b>
Description .....	page 1
Options Complement .....	page 2
Performance Specifications.....	page 3
Inputs/Outputs.....	page 4
Functional Theory of Operation.....	page 5
<b>UHF TRIPLE CIRCULATOR OPTION (OPTIONS X676AN AND X676AP)</b> .....	<b>68P81088E54</b>
Description .....	page 1
Option Complement .....	page 2
Performance Specifications.....	page 3
Inputs/Outputs.....	page 4
Functional Theory of Operation.....	page 5
<b>800/900 MHz TRIPLE CIRCULATOR OPTION (OPTIONS X676AR AND X676AQ)</b> .....	<b>68P81090E86</b>
Description .....	page 1
Option Complement .....	page 2
Performance Specifications.....	page 2
Inputs/Outputs.....	page 3
Functional Theory of Operation.....	page 4

## DUPLEXER OPTIONS

<b>VHF DUPLEXERS (OPTIONS X182AA, AB, AJ)</b> .....	<b>68P81086E71</b>
Description .....	page 1
Adjustments and Inputs/Outputs .....	page 2
Performance Specifications.....	page 3
Typical Mounting Configuration .....	page 3
Field Tuning Procedure .....	page 6
<b>UHF DUPLEXER (OPTIONS X182AC THROUGH X182AF)</b> .....	<b>68P81087E94</b>
Description .....	page 1
Inputs/Outputs.....	page 2
Performance Specifications.....	page 3
Typical Mounting Configuration .....	page 4

---

<b>Field Tuning Procedure</b> .....	<b>page 6</b>
Field Tuning Overview .....	page 6
Required Test Equipment .....	page 6
Setting Up for Tuning Duplexer .....	page 7
Duplexer Tuning Procedure .....	page 8

<b>800/900 MHz DUPLEXERS (OPTIONS X182AG AND X182AH)</b> .....	<b>68P81091E93</b>
<b>Description</b> .....	<b>page 1</b>
<b>Inputs/Outputs</b> .....	<b>page 2</b>
<b>Performance Specifications</b> .....	<b>page 3</b>
<b>Typical Mounting Configuration</b> .....	<b>page 3</b>

**MODEM OPTION**

<b>ASTRO MODEM CARD (OPTION X437AA)</b> .....	<b>68P81086E38</b>
<b>Description</b> .....	<b>page 1</b>

**PERIPHERAL TRAY OPTION**

<b>PERIPHERAL TRAY (OPTION X696AA)</b> .....	<b>68P81086E37</b>
<b>Description</b> .....	<b>page 1</b>
<b>Options Complement</b> .....	<b>page 2</b>
<b>Peripheral Tray Contents and Inputs/Outputs</b> .....	<b>page 3</b>

**UHSO OPTION**

<b>ULTRA HIGH STABILITY OSCILLATOR (UHSO; OPTION X873AA)</b> .....	<b>68P81088E08</b>
<b>Description</b> .....	<b>page 1</b>
<b>Inputs/Outputs</b> .....	<b>page 2</b>
<b>Functional Theory of Operation</b> .....	<b>page 3</b>

## **SYSTEM APPLICATIONS**

<b>RA/RT CONFIGURATION (TRC CONTROL)</b> .....	<b>68P81090E98</b>
<b>Overview</b> .....	<b>page 1</b>
<b>Electrical Connections (RF Link)</b> .....	<b>page 2</b>
Console to Station 1 Wiring Connections .....	page 2
Station 2 to Station 3 Wiring Connections .....	page 3
<b>Electrical Connections (Microwave Link)</b> .....	<b>page 4</b>
Console to Microwave Station 1 Wiring Connections .....	page 4
Microwave Station 2 to Station 3 Wiring Connections .....	Page 5
<b>RSS Programming</b> .....	<b>page 6</b>
<b>TX Wireline Alignment</b> .....	<b>page 7</b>
Station 1 TX Wireline Alignment .....	page 7

---

Station 2 TX Wireline Alignment .....	page 7
Station 3 TX Wireline Alignment .....	page 8
<b>RA/RT CONFIGURATION (E &amp; M KEYING) .....</b>	<b>68P81090E99</b>
<b>Overview .....</b>	<b>page 1</b>
<b>Electrical Connections (RF Link) .....</b>	<b>page 2</b>
Console to Station 1 Wiring Connections .....	page 2
Station 2 to Station 3 Wiring Connections .....	page 3
<b>Electrical Connections (Microwave Link) .....</b>	<b>page 5</b>
Console to Microwave Station 1 Wiring Connections .....	page 5
Microwave Station 2 to Station 3 wiring Connections .....	page 6
<b>RSS Programming .....</b>	<b>page 8</b>
<b>TX Wireline Alignment .....</b>	<b>page 9</b>
Station 1 TX Wireline Alignment .....	page 9
Station 2 TX Wireline Alignment .....	page 9
Station 3 TX Wireline Alignment .....	page 10
<b>FALL BACK IN-CABINET REPEAT FEATURE .....</b>	<b>68P81095E96</b>
<b>Overview .....</b>	<b>page 1</b>
<b>Configuring the FBICR Feature .....</b>	<b>page 4</b>
<b>MAIN/STANDBY CONFIGURATION .....</b>	<b>68P81095E89</b>
<b>Overview .....</b>	<b>page 1</b>
<b>Electrical Connections .....</b>	<b>page 2</b>
<b>Setting Wireline Impedance Jumpers .....</b>	<b>page 4</b>
<b>RSS Programming .....</b>	<b>page 5</b>
<b>Main/Standby Operation .....</b>	<b>page 6</b>
<b>Customizing Main/Standby Operation .....</b>	<b>page 8</b>
<b>FAST KEYUP FEATURE .....</b>	<b>68P80800A02</b>
<b>Overview .....</b>	<b>page 1</b>
<b>Electrical Connections .....</b>	<b>page 2</b>
<b>RSS Programming .....</b>	<b>page 4</b>
<b>Fast Keyup Performance Characteristics .....</b>	<b>page 5</b>
<b>DUAL CONTROL OF GATED ADDRESS VIA TRC AND SAM .....</b>	<b>68P81096E11</b>
<b>Overview .....</b>	<b>page 1</b>
<b>Station RSS Programming .....</b>	<b>page 4</b>
<b>SAM RSS Programming .....</b>	<b>page 8</b>

---

---

<b>INPUT/OUTPUT SPECIFICATIONS FOR EXTERNAL CONTROLLERS</b> .....	<b>68P81096E86</b>
<b>Overview</b> .....	<b>page 1</b>
<b>Electrical Connections</b> .....	<b>page 2</b>
<b>Electrical Characteristics</b> .....	<b>page 3</b>
<b>Editing Wildcard Tables</b> .....	<b>page 8</b>
<b>SERIAL INTERFACE SPECIFICATIONS</b> .....	<b>68P81131E57</b>
<b>Overview</b> .....	<b>page 1</b>
<b>Making Serial Connection to Station</b> .....	<b>page 1</b>
<b>Entering “RSS Mode”</b> .....	<b>page 3</b>
<b>Supported Commands</b> .....	<b>page 4</b>
<b>Important Things to Know</b> .....	<b>page 12</b>

---

# FOREWORD

---

## Product Maintenance Philosophy

Due to the high percentage of surface-mount components and multi-layer circuit boards, the maintenance philosophy for this product is one of Field Replaceable Unit (FRU) substitution. The station is comprised of self-contained modules (FRUs) which, when determined to be faulty, may be quickly and easily replaced with a known good module to bring the equipment back to normal operation. The faulty module must then be shipped to the Motorola System Support Center for further troubleshooting and repair to the component level.

---

## Scope of Manual

This manual is intended for use by experienced technicians familiar with similar types of equipment. In keeping with the maintenance philosophy of Field Replaceable Units (FRU), this manual contains functional information sufficient to give service personnel an operational understanding of all FRU modules, allowing faulty FRU modules to be identified and replaced with known good FRU replacements.

The information in this manual is current as of the printing date. Changes which occur after the printing date are incorporated by Instruction Manual Revisions (SMR). These SMRs are added to the manuals as the engineering changes are incorporated into the equipment.

---

## Service and Replacement Modules

For complete information on ordering FRU replacement modules, or instructions on how to return faulty modules for repair, contact the System Support Center:

**Motorola System Support Center**  
2214 Galvin Drive  
Elgin, IL 60123  
1-800-221-7144  
Int'l 1-847-576-7300  
FAX 1-847-576-2172

The following FRU replacement modules are available:

Receiver Module (VHF Range 1)	TLN3250
Receiver Module (VHF Range 2)	TLN3251
Receiver Module (UHF Range 0)	DLN1215
Receiver Module (UHF Range 1)	TLN3313
Receiver Module (UHF Range 2)	TLN3314
Receiver Module (UHF Range 3)	TLN3373
Receiver Module (UHF Range 4)	TLN3374
Receiver Module (800 MHz)	TLN3315
Receiver Module (900 MHz)	TLN3316
Exciter Module (VHF Range 1)	TLN3252
Exciter Module (VHF Range 2)	TLN3253
Exciter Module (UHF Range 0)	DLN1214
Exciter Module (UHF Range 1)	TLN3305
Exciter Module (UHF Range 2)	TLN3306
Exciter Module (UHF Range 3)	TLN3375
Exciter Module (UHF Range 4)	TLN3376
Exciter Module (800 MHz)	TLN3307
Exciter Module (900 MHz)	TLN3308
Power Amplifier Module (VHF 25W, R1 & R2)	TLN3255
Power Amplifier Module (VHF 125W, R1)	TLN3379
Power Amplifier Module (VHF 125W, R2)	TLN3254
Power Amplifier Module (UHF Range 0; 110W)	DLN1216
Power Amplifier Module (UHF Range 1; 25W)	TLN3443
Power Amplifier Module (UHF Range 2; 110W)	TLN3446
Power Amplifier Module (UHF Range 4; 100W)	TLN3450
Power Amplifier Module (800 MHz 20W)	TLN3441
Power Amplifier Module (800 MHz 100W)	TLN3442
Power Amplifier Module (900 MHz 100W)	TLN3299
Station Control Module (Conventional/6809)	CLN1293
Station Control Module (Conventional/6809 <i>EPIC III</i> )	CLN1621
Station Control Module (EPIC IV)	CLN7692
Station Control Module ( <i>IntelliRepeater</i> )	CLN1294
4-Wire Wireline Interface Module	CLN1295
8-Wire Wireline Interface Module	CLN1296
Power Supply Module (625W AC)	TLN3259
Power Supply Module (625W AC w/charger)	TLN3260
Power Supply Module (265W AC)	TLN3261
Power Supply Module (265W AC w/charger)	TLN3262
Power Supply Module (210W 12/24 V DC)	TLN3264
Power Supply Module (210W 48/60 V DC)	TLN3378
Power Supply Module (600W 24 V DC)	TLN3263
Power Supply Module (600W 48/60 V DC)	TLN3377
ASTRO Modem Card	TLN3265



---

## GENERAL SAFETY INFORMATION

The following general safety precautions must be observed during all phases of operation, service, and repair of the equipment described in this manual. The safety precautions listed below represent warnings of certain dangers of which we are aware. You should follow these warnings and all other safety precautions necessary for the safe operation of the equipment in your operating environment.

---

### General Safety Precautions

- Read and follow all warning notices and instructions marked on the product or included in this manual before installing, servicing or operating the equipment. Retain these safety instructions for future reference. Also, all applicable safety procedures, such as Occupational, Safety, and Health Administration (OSHA) requirements, National Electrical Code (NEC) requirements, local code requirements, safe working practices, and good judgement must be used by personnel.
- Refer to appropriate section of the product service manual for additional pertinent safety information.
- Because of danger of introducing additional hazards, do not install substitute parts or perform any unauthorized modifications of equipment.
- Identify maintenance actions that require two people to perform the repair. Two people are required when:
  - A repair has the risk of injury that would require one person to perform first aid or call for emergency support. An example would be work around high voltage sources. A second person may be required to remove power and call for emergency aid if an accident occurs to the first person. **Note** Use the National Institute of Occupational Safety and Health (NIOSH) lifting equation to determine whether a one or two person lift is required when a system component must be removed and replaced in its rack.
- If troubleshooting the equipment while power is applied, be aware of the live circuits.
- DO NOT operate the transmitter of any radio unless all RF connectors are secure and all connectors are properly terminated.
- All equipment must be properly grounded in accordance with *Motorola Standards and Guideline for Communications Sites 68P81089E50* (sometimes referred to as "R56 Manual") and specified installation instructions for safe operation.
- Slots and openings in the cabinet are provided for ventilation. To ensure reliable operation of the product and to protect it from overheating, these slots and openings must not be blocked or covered.
- Only a qualified technician familiar with similar electronic equipment should service equipment.
- Some equipment components can become extremely hot during operation. Turn off all power to the equipment and wait until sufficiently cool before touching.
- Never store combustible materials in or near equipment racks. The combination of combustible material, heat, and electrical energy increases the risk of a fire safety hazard.

---

### Human Exposure Compliance

This equipment is designed to generate and radiate radio frequency (RF) energy by means of an external antenna. When terminated into a non-radiating RF load, the base station equipment is certified to comply with Federal Communications Commission (FCC) regulations pertaining to human

---

exposure to RF radiation In accordance with the FCC Rules Part 1 section 1.1310 as published in title 47 code of federal regulations and procedures established in TIA/EIA TSB92, Report On EME Evaluation for RF Cabinet Emissions Under FCC MPE Guidelines. Compliance to FCC regulations of the final installation should be assessed and take into account site specific characteristics such as type and location of antennas, as well as site accessibility of occupational personnel (controlled environment) and the general public (uncontrolled environment). This equipment should only be installed and maintained by trained technicians. Licensees of the FCC using this equipment are responsible for insuring that its installation and operation comply with FCC regulations Part 1 section 1.1310 as published in title 47 code of federal regulations.

Whether a given installation meets FCC limits for human exposure to radio frequency radiation may depend not only on this equipment but also on whether the “environments” being assessed are being affected by radio frequency fields from other equipment, the effects of which may add to the level of exposure. Accordingly, the overall exposure may be affected by radio frequency generating facilities that exist at the time the licensee's equipment is being installed or even by equipment installed later. Therefore, the effects of any such facilities must be considered in site selection and in determining whether a particular installation meets the FCC requirements.

FCC OET Bulletin 65 provides materials to assist in making determinations if a given facility is compliant with the human exposure to RF radiation limits. Determining the compliance of transmitter sites of various complexities may be accomplished by means of computational methods. For more complex sites direct measurement of the power density may be more expedient. Additional information on the topic of electromagnetic exposure is contained in the *Motorola Standards and Guideline for Communications Sites* publication. Persons responsible for installation of this equipment are urged to consult the listed reference material to assist in determining whether a given installation complies with the applicable limits.

---

In general the following guidelines should be observed when working in or around radio transmitter sites: ~ All personnel should have electromagnetic energy awareness training

- All personnel entering the site must be authorized ~ Obey all posted signs
- Assume all antennas are active
- Before working on antennas, notify owners and disable appropriate transmitters
- Maintain minimum 3 feet clearance from all antennas ~ Do not stop in front of antennas
- Use personal RF monitors while working near antennas
- Never operate transmitters without shields during normal operation ~ Do not operate base station antennas in equipment rooms

For installations outside of the U.S., consult with the applicable governing body and standards for RF energy human exposure requirements and take the necessary steps for compliance with local regulations.

---

## References

- TIA/EIA TSB92 "Report On EME Evaluation for RF Cabinet Emissions Under FCC MPE Guidelines," Global Engineering Documents: <http://global.ihs.com/>
- FCC OET Bulletin 65 "Evaluating Compliance with FCC Guidelines for Human Exposure to Radio frequency Electromagnetic Fields": <http://www.fcc.gov/oet/rfsafety/>
- *Motorola Standards and Guideline for Communications Sites*, Motorola manual 68P81089E50
- IEEE Recommended Practice for the Measure of Potentially Hazardous Electromagnetic Fields – RF and Microwave, IEEE Std C95.3–1991, Publication Sales, 445 Hoes Lane, P.O. Box 1331, Piscataway, NJ 08855-1331
- IEEE Standard for Safety Levels with Respect to Human Exposure to Radio Frequency Electromagnetic Fields, 3 kHz to 300 GHz, IEEE C95.1–1991, Publication Sales, 445 Hoes Lane, P.O. Box 1331, Piscataway, NJ 08855-1331

# PERFORMANCE SPECIFICATIONS

## General

TX Sub-Band Range	<b>VHF</b> 132–154 MHz (R1) 150–174 MHz (R2)	<b>UHF</b> 380–433 MHz (R0) 403–433 MHz (R1) 438–470 MHz (R2) 470–494 MHz (R3) 494–520 MHz (R4)	<b>800</b> 851–870 MHz	<b>900</b> 935–941 MHz
RX Sub-Band Range	<b>VHF</b> 132–154 MHz (R1) 150–174 MHz (R2)	<b>UHF</b> 380–433 MHz (R0) 403–433 MHz (R1) 438–470 MHz (R2) 470–494 MHz (R3) 494–520 MHz (R4)	<b>800</b> 806–825 MHz	<b>900</b> 896–902 MHz
Number of Channels	16			
Channel Spacing	<b>VHF:</b> 30, 25, 12.5 kHz	<b>UHF/800:</b> 12.5, 25 kHz	<b>900:</b> 12.5 kHz	
Frequency Generation	Synthesized			
Power Supply Type	Switching			
Power Supply Input Voltage	90–280 V ac			
Power Supply Input Frequency	47–63 Hz			
Battery Revert	12V (25W radios) 24V (100W, 110W, and 125W radios)			
T/R Separation (without duplexer option)	<b>VHF/UHF:</b> Any spacing within same sub-band		<b>800:</b> 45 MHz	<b>900:</b> 39 MHz
T/R Separation (with duplexer option)	<b>VHF/UHF:</b> $\geq 1.5$ MHz		<b>800:</b> 45 MHz	<b>900:</b> 39 MHz
Temperature Range (ambient)	–30° C to +60° C			

# PERFORMANCE SPECIFICATIONS (Cont'd)

## Receiver

I–F Frequencies	<b>VHF</b> 21.45 MHz (1st) 450 kHz (2nd)	<b>UHF</b> 73.35 MHz (1st) 450 kHz (2nd)	<b>800</b> 73.35 MHz (1st) 450 kHz (2nd)	<b>900</b> 73.35 MHz (1st) 450 kHz (2nd)
Preselector Bandwidth	<b>VHF/UHF:</b> 4 MHz		<b>800:</b> 19 MHz	<b>900:</b> 6 MHz
Sensitivity (12 dB SINAD)	<b>VHF:</b> 0.25 $\mu$ V	<b>UHF:</b> 0.35 $\mu$ V	<b>800/900:</b> 0.30 $\mu$ V	
Sensitivity (20 dB Quieting)	<b>VHF:</b> 0.35 $\mu$ V	<b>UHF:</b> 0.5 $\mu$ V	<b>800/900:</b> 0.42 $\mu$ V	
Adjacent Channel Rejection	<b>VHF</b> 90 dB (25/30 kHz) 80 dB (23.5 kHz)	<b>UHF</b> 75 dB (12.5 kHz) 85 dB (25 kHz)	<b>800</b> 70 dB (12.5 kHz) 80 dB (25 kHz)	<b>900</b> 70dB 80 db (25 kHz)
Intermodulation Rejection	<b>VHF</b> 85 dB (25/30 kHz) 80 dB (30 kHz)	<b>UHF</b> 85 dB	<b>800</b> 85 dB	<b>900</b> 70 dB
Spurious and Image Rejection	100 dB			
Wireline Output	–20 dBm to 0 dBm @ 60% Rated System Deviation, 1 kHz			
Audio Response (Analog Mode)	+1, –3 dB from 6 dB per octave de–emphasis; 300–3000 Hz referenced to 1000 Hz at line input			
Audio Distortion	Less than 3% @ 1000 Hz			
FM Hum and Noise (300 to 3000 kHz bandwidth)	<b>VHF</b> 50 dB (25/30 kHz) 45 dB (12.5 kHz)	<b>UHF</b> 45 dB (12.5 kHz) 50 dB (25 kHz)	<b>800</b> 45 dB (12.5 kHz) 50 dB (25 kHz)	<b>900</b> 45 db
Frequency Stability	<b>VHF/UHF/800:</b> 1 ppm		<b>900:</b> 0.1 ppm	
RF Input Impedance	50 $\Omega$			
FCC Designation (FCC Rule Part 15)	<b>VHF:</b> ABZ89FR3776 <b>900:</b> ABZ89FR5768	<b>UHF:</b> ABZ89FR4796	<b>800:</b> ABZ89FR5757	

# PERFORMANCE SPECIFICATIONS (Cont'd)

## Transmitter

Power Output	<b>VHF</b> 6–25W 25–125W	<b>UHF</b> 5–25W 25–110W	<b>800</b> 5–20W 20–100W	<b>900</b> 25–100W
Electronic Bandwidth	Full sub-band			
Intermodulation Attenuation	<b>VHF:</b> 20 dB (single circulator; standard on all PAs) 65 dB (triple circulator – requires triple circulator option) <b>UHF:</b> 50 dB (single circulator; standard on all PAs) <b>800:</b> 50 dB (single circulator; standard on all PAs) <b>900:</b> 20 dB (single circulator; standard on all PAs) 70 dB (triple circulator – requires triple circulator option)			
Spurious and Harmonic Emissions Attenuation	90 dB			
Deviation	<b>VHF, UHF, and 800</b> ±5 kHz (25 kHz) ±2.5 kHz (12.5 kHz)		<b>900</b> ±2.5 kHz	
Audio Sensitivity	–35 dBm to 0 dBm (variable)			
Audio Response (Analog Mode)	+1, –3 dB from 6 dB per octave pre-emphasis; 300–3000 Hz referenced to 1000 Hz at line input			
Audio Distortion	Less than 2% @ 1000 Hz @ 60% rated system deviation			
FM Hum and Noise (300 to 3000 Hz bandwidth)	45 dB nominal (12.5 kHz) 50 dB nominal (25/30 kHz)			
Frequency Stability	<b>VHF, UHF, 800:</b> 1 ppm		<b>900:</b> 0.1ppm	
RF Output Impedance	50 Ω			
FCC Designation	<b>VHF</b> 25W: ABZ89FC3774 (FCC Rule Parts 22, 74, 80, 90) 125W: ABZ89FC3773 (FCC Rule Parts 22, 74, 80, 90)			
	<b>UHF</b> 25W/R1–2: ABZ89FC4797 (FCC Rule Parts 22, 74, 90) 110W/R0: ABZ89FC4798-A (FCC Rule Part 90) 110W/R1–3: ABZ89FC4798 (FCC Rule Parts 22, 90) 100W/R4: ABZ89FC4798 (FCC Rule Part 74)			
	<b>800</b> 20W: ABZ89FC5775 (FCC Rule Parts 22, 90) 100W: ABZ89FC5776 (FCC Rule Parts 22, 90)			
FCC Designation	<b>900</b> 100W: ABZ89FC5767 (FCC Rule Part 90)			

Measurement Methods per TIA/EIA–603  
 Specifications subject to change without notice

END OF PART 1

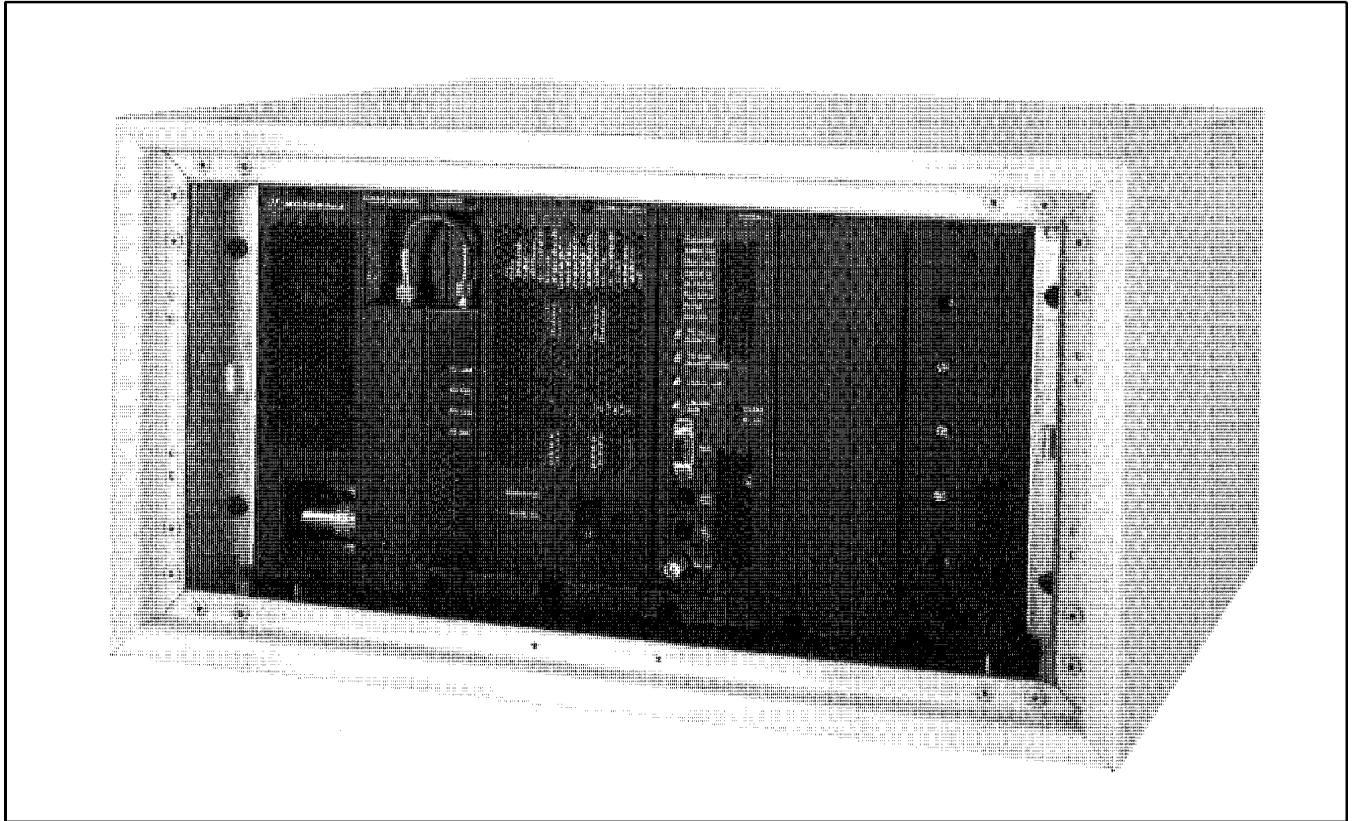

**Figure 1.** *Quantar* Station in 12" Cabinet (UHF Shown)

## **1** INTRODUCTION

The Motorola *Quantar* Station (available in VHF, UHF, 800 MHz and 900 MHz) provides conventional analog, *ASTRO*, *ASTRO CAI*, 6809 Trunking, and *IntelliRepeater* capabilities in a compact, software-controlled design. The station architecture and microprocessor-controlled Station Control Module allow for fast and reliable expansion and upgrading. FLASH memory in the Station Control Module allows software downloads to be performed locally (using serial or Ethernet port) or remotely via modem.

### **Compact Mechanical Design**

The entire *Quantar* station is housed in a 5 rack-unit-high card cage weighing only 55 lbs. A single cage may be mounted in a 12" cabinet (shown in Figure 1) or multiple cages may be mounted in standard telephone-style equipment racks or various sizes of Motorola cabinets.

---

## State-of-the-Art Electrical Design

### ***Transmitter Circuitry***

The station transmitter circuitry is designed for continuous duty operation and may be operated at full-rated power. Output power is continually monitored by an internal calibrated wattmeter. The wattmeter output feeds a power control loop which continually adjusts and maintains the desired output power. All adjustments are electronic, including deviation and output power.

### ***Receiver Circuitry***

The station receive circuitry features multiple bandwidth capability (12.5, 25, or 30 kHz, depending on band), as well as *ASTRO* digital operation. Injection signals for the 1st and 2nd mixers are generated by frequency synthesizer circuitry electronically controlled by the Station Control Module. All receive signals (analog, *ASTRO*, and *ASTRO CAI*) are detected and digitized before being sent to the Station Control Module, providing improved audio quality consistency throughout the coverage area.

### ***Station Control Module***

The *Quantar* Station Control Module is microprocessor-based and features extensive use of ASIC and digital signal processing technology. The module serves as the main controller for the station, providing signal processing and operational control for the station modules.

### ***Wireline Circuitry***

The station wireline circuitry provides a wide variety of telephone interfaces, including analog, *ASTRO*, *ASTRO CAI*, Tone Remote Control, DC Remote Control, and WildCard I/O connections. Telephone line connections are easily made to the wireline circuitry via connectors on the rear of the station.

### ***Switching Power Supply***

The *Quantar* station features a switching-type power supply which accepts a wide range of ac inputs (90–280 V ac, 47–63 Hz) and generates the necessary dc operating voltages for the station modules. The power supply continually monitors and adjusts the output voltages, and requires no external adjustments or calibration.



---

## Summary of Operating Features

### **Standard Features**

The following are a few of the standard *Quantar* features:

- Compact, single cage design
- Extensive Self-Test Diagnostics and Alarm Reporting
- FRU maintenance philosophy (reduces down time)
- Easily programmed via Radio Service Software
- Local or Remote Software downloading to FLASH memory
- Expansion and upgrades performed by module replacement and/or software upgrade
- Highly reliable and accurate continuous duty transmitter circuitry
- Operates as *IntelliRepeater* trunking station
- Compatible (with appropriate options) with analog, *ASTRO* and *ASTRO CAI* digital signaling
- Versatile and reliable switching-type power supply
- Wide operating temperature range:  $-30^{\circ}\text{C}$  to  $+60^{\circ}\text{C}$  ( $-22^{\circ}\text{F}$  to  $+140^{\circ}\text{F}$ )

### **Optional Hardware Features**

The following are a few of the *Quantar* station optional hardware features:

- **Battery Revert** — charges co-located storage batteries and automatically reverts to battery backup operation in the event of ac power failure
- **Triple Circulator Option** — provides additional isolation and intermodulation protection for rf-congested transmitter sites
- **Duplexer Option** — allows a single antenna to serve for both transmitter and receiver circuitry in repeater applications
- **Antenna Relay Option** — allows a single antenna to be switched between transmitter and receiver circuitry for base station applications
- **UHSO Option** — ultra-high stability oscillator provides improved station frequency accuracy required for some system types
- **ASTRO Modem** — allows connection (for *ASTRO* digital signaling) to a console through a Digital Interface Unit (DIU) in an *ASTRO* system
- **Station Access Module (SAM)** — allows station to decode MDC Repeater Access (e.g., Select5, DTMF, etc.)
- **Wide Space Receiver** — provides 8 MHz receiver bandwidth for VHF and UHF stations

---

## Multiple System Capability

In addition to conventional capabilities, the *Quantar* station can be programmed to operate in 6809 Trunking and *IntelliRepeater* Trunking systems.

### **6809 Trunking**

When programmed for 6809 Trunking capability, the station can operate in a *SMARTNET* trunking system under control of a 6809 Trunking Controller.

### **IntelliRepeater Trunking**

When programmed for *IntelliRepeater* capability, the *Quantar* station can operate in Motorola's most advanced wide-area trunking systems — *SMARTZONE*. The station can operate both as a remote voice channel and, if necessary, perform all call processing and channel assignment tasks normally requiring a trunking controller.

## **2** STATION COMPONENTS

Figure 2 shows the *Quantar* station modules and components (UHF shown).

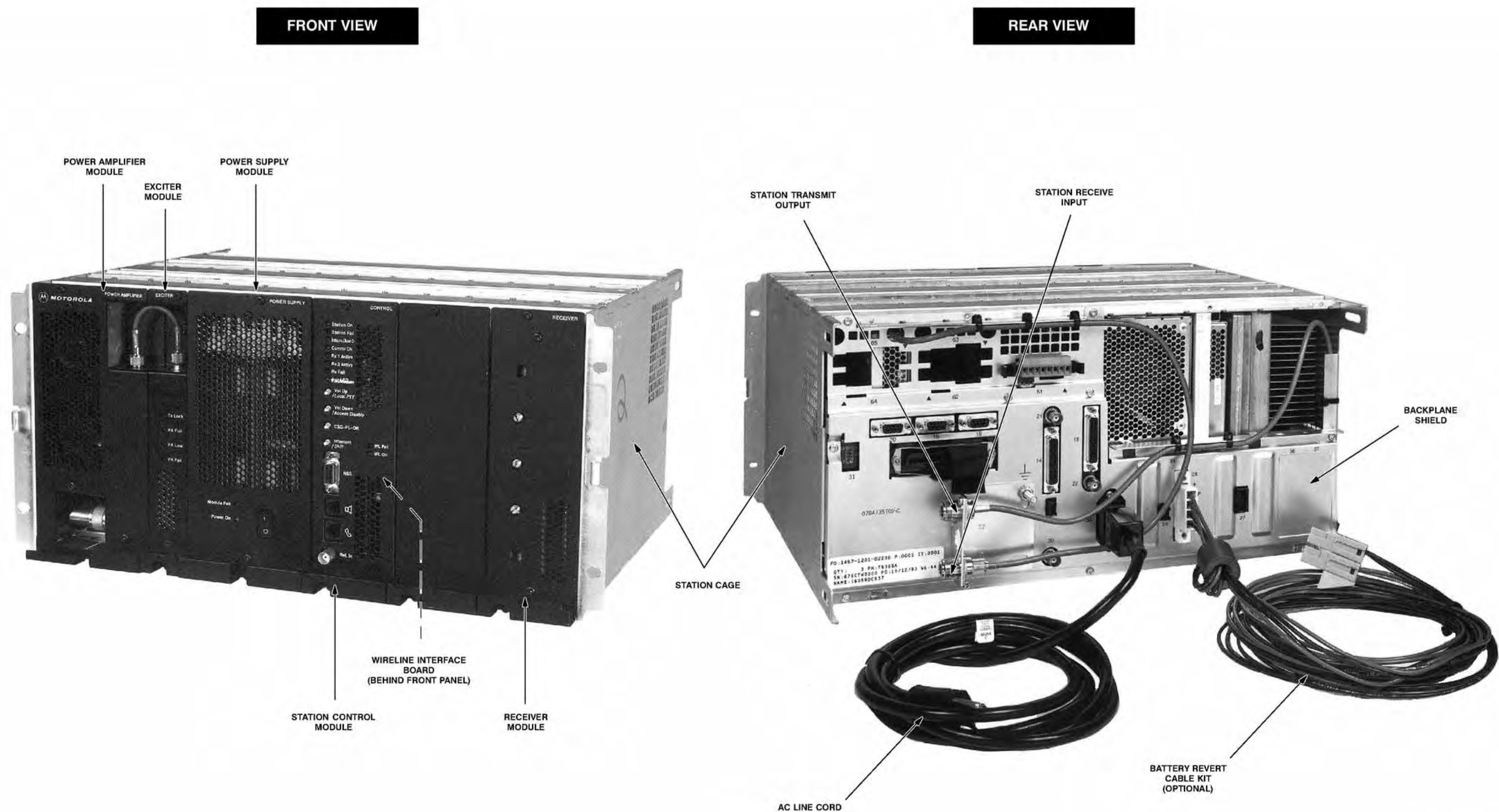

Figure 2. Quantar Station Components (Front and Rear Views; UHF Shown)

## 3 FUNCTIONAL THEORY OF OPERATION

The following functional theory of operation provides an overview of the station circuitry. For a more thorough functional description of a particular module, refer to the functional sections located behind the tab **STATION MODULES**. Refer to the block diagram in Figure 3 for the following functional theory of operation.

### Transmitter Circuitry Operation

#### **Introduction**

The Transmitter Circuitry is comprised of the Exciter Module and the Power Amplifier (PA) Module. These modules combine to produce the modulated, amplified rf signal which is transmitted via the site transmit antenna.

#### **Exciter Module Operation**

The Exciter Module is a microprocessor-controlled module which generates a modulated rf signal at the desired transmit frequency and sends this signal to the PA for amplification. The circuitry operates as follows.

The synthesizer/VCO accepts frequency programming data from the Station Control Module (via the SPI bus) and generates an rf carrier signal at the specified frequency. The modulation audio signal (from the SCM) modulates the carrier, resulting in a modulated rf signal at approximately +13 dBm which is fed to the PA.

The TX Power Control Circuitry accepts an output power detect voltage from the PA and compares this signal to a reference voltage representing the desired output power. Based on the comparison, a power control voltage is generated to control the output power from the PA. This feedback and control loop continually monitors the output power and adjusts the control voltage to maintain the proper output power from the PA.

#### **Power Amplifier Module Operation**

The modulated rf signal from the Exciter Module is input to the Intermediate Power Amplifier (IPA) in the PA. After amplification to approximately 0–10 W (depending on power control voltage from Exciter Module), the signal is fed to a Driver or a Final module (depending on station's maximum output power). The gain of the IPA stage is controlled by the power control voltage from the Exciter Module.

The modulated rf signal is amplified by the Driver and/or Final and is output to the site transmit antenna via a circulator and a harmonic filter/coupler. The coupler consists of a calibrated wattmeter which feeds a dc voltage proportional to the output power to the TX Power Control Circuitry in the Exciter Module to serve as the feedback signal in the power control loop.

---

## Receiver Circuitry Operation

### **Introduction**

The Receiver Circuitry accepts receive rf signals from the site receive antenna, performs filtering and dual conversion, and outputs a digitized receive signal to the Station Control Module.

### **Receiver Module Operation**

The receive signal is input from the site receive antenna to a multi-pole preselector filter which provides highly selective bandpass filtering. The filtered signal is then amplified and fed to the rf input of the 1st mixer, which mixes the signal with an injection signal generated by the synthesizer/VCO, resulting in a 21.45 MHz (VHF) or a 73.35 MHz (UHF, 800, 900) 1st i-f (intermediate frequency) signal. (The injection signal frequency is determined by frequency programming data from the Station Control Module via the SPI bus.)

The 21.45 MHz or 73.35 MHz 1st i-f signal is filtered and input to a custom receiver IC. This component contains circuitry for 2nd injection and mixing, amplification, and A/D (analog to digital) conversion, resulting in a digitized receive signal. This signal is fed as differential data to the Station Control Module.

---

## Station Control Module Operation

### **Introduction**

The Station Control Module (SCM) is the microprocessor-based controller for the station. Major components include an MC68360 microprocessor, a 56002 Digital Signal Processor (DSP), and two ASIC devices (host and DSP). The SCM operates as follows.

### **Station Control Module Operation**

The Host Microprocessor ( $\mu$ P) serves as the controller for the SCM, operating from the station software stored in FLASH memory. This software determines the system capabilities of the station (analog, *ASTRO*, etc.) The Host  $\mu$ P communicates with the station modules and the SCM circuitry via address and data buses, an HDLC bus, and a SPI bus. External communications ports include a serial port SCM front panel and backplane) and an Ethernet port (backplane).

The DSP and DSP ASIC perform the necessary digital processing for the station audio and data signals. The DSP circuitry interfaces with the Receiver Module (receive audio), the Exciter Module (modulation signal), the Wireline Interface Board (wireline audio), and external audio devices (microphone, handset, external speaker, and station local speaker).

The 2.1 MHz Reference Oscillator generates the reference signal used by the Receiver and Exciter Modules.

---

## Wireline Interface Board Operation

**Note:** The WIB is offered in 4-wire and 8-wire models. The WIB shown in the block diagram is a simplified 4-wire model. Refer to the functional sections located behind tab WIRELINE CIRCUITRY for details on both models.

### Introduction

The Wireline Interface Board (WIB) serves as the interface between the customer telephone lines and the station. In general, the WIB processes and routes all wireline audio signals between the station and the landline equipment (such as consoles, modems, etc.). Landline-to-station and station-to-landline audio signals are connected to the WIB via copper pairs at the rear of the station.

### Wireline Interface Board Operation

The WIB contains a microprocessor, two FLASH memory ICs (which contain the WIB operating software downloaded by the SCM), and an ASIC device to process and route the various audio signals. Analog and ASTRO signals are processed as follows.

- Analog signals are converted to digital signals and routed to the SCM via the TDM (time division multiplex) bus.
- ASTRO and ASTRO CAI data signals are processed by an ASTRO modem card (daughter board plugged into the WIB) and sent to/from the SCM via the HDLC bus. (The station operates in *transparent* mode only, and **does not** perform encryption or decryption of the ASTRO or ASTRO CAI signal.)

The WIB also contains the I/O circuitry used with the WildCard Option. Refer to the *Quantar/Quantro* RSS User's Guide (68P81085E35) for more information on the WildCard Option.

---

## Power Supply Module Operation

The Power Supply Module is a switching-type power supply which accepts an ac input (90–280 V ac, 47–63 Hz) and generates the necessary dc operating voltages for the station modules. Stations rated at 20/25 W output power are equipped with Power Supply Modules which generate +5 and +14.2 V dc. Stations rated at 100/110/125 W output power are equipped with Power Supply Modules which generate +5, +14.2 V, and +28 V dc.

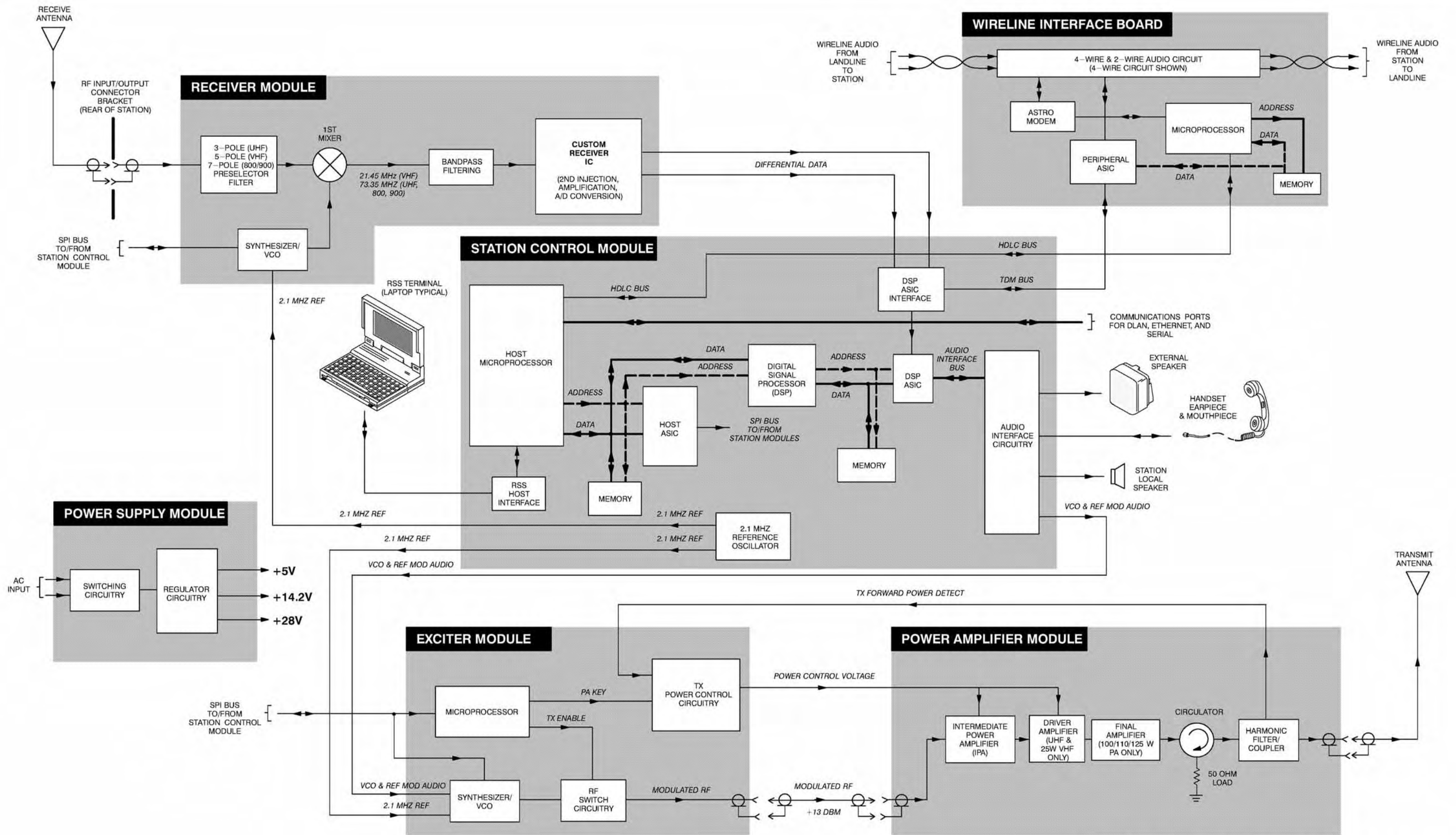

Figure 3. Quantar Station Functional Block Diagram



---

---

## Contents

<b>1. Pre-Installation Considerations</b> . . . . .	<b>2</b>	<b>3. Electrical Connections</b> . . . . .	<b>28</b>
Installation Overview . . . . .	2	Power Supply Connections . . . . .	28
Environmental Conditions at Intended Site . . . . .	3	AC Input Power Connection . . . . .	28
Equipment Ventilation . . . . .	3	DC Input Power Connection . . . . .	29
AC Input Power Requirements . . . . .	4	Ground Connection . . . . .	30
Equipment Mounting Methods . . . . .	4	Storage Battery Connections . . . . .	31
Site Grounding and Lightning Protection . . . . .	5	RF Cabling Connections . . . . .	32
Recommended Tools and Equipment . . . . .	6	Introduction . . . . .	32
Equipment Unpacking and Inspection . . . . .	6	Separate RX and TX Connectors . . . . .	33
Physical Dimensions and Clearances . . . . .	7	Antenna Relay Option . . . . .	34
<i>Quantar</i> Cage without Cabinet . . . . .	7	Duplexer Option . . . . .	35
<i>Quantar</i> Cages Installed in 7', 7½' and 8' Racks . . . . .	8	Connecting System Cables . . . . .	38
<i>Quantar</i> Cages Installed in Modular Racks . . . . .	9	Introduction . . . . .	38
12" x 20" Cabinet . . . . .	10	<i>IntelliRepeater</i> D-LAN Cabling Connections . . . . .	38
30" x 20" Cabinet . . . . .	11	<i>IntelliRepeater</i> Ethernet Cabling Connections . . . . .	40
46" x 20" Cabinet . . . . .	12	6809 Trunking Cabling Connections . . . . .	42
60" Indoor Cabinet . . . . .	13	Zone Controller Cabling Connections . . . . .	43
		6809 Controller TSC/CSC Link Connections . . . . .	44
<b>2. Mechanical Installation</b> . . . . .	<b>14</b>	Connecting Telephone Lines . . . . .	46
Unpacking the Equipment . . . . .	14	Introduction . . . . .	46
Introduction . . . . .	14	Telephone Line Specifications . . . . .	46
Unpacking Standalone <i>Quantar</i> Station Cage . . . . .	14	Location of Telephone Line Connections . . . . .	47
Unpacking 12" x 20" Cabinet . . . . .	16	2-Wire / 4-Wire Jumper Setting . . . . .	48
Unpacking 30", 46", and 60" Cabinets . . . . .	18	Input/Output Impedance Matching Jumpers . . . . .	48
Mounting Procedures . . . . .	20	System Type vs Wireline Circuit Matrix . . . . .	48
Introduction . . . . .	20	Connecting V.24 Modems . . . . .	50
Mounting Cage in Customer-Supplied Cabinet . . . . .	20	Connecting External Reference . . . . .	51
Mounting Cage in Customer-Supplied Rack . . . . .	22	Overview . . . . .	51
Installing 7', 7½', and 8' and Modular Racks . . . . .	24	Single Station Connections . . . . .	51
Mounting 30", 46" and 60" Cabinets . . . . .	24	Multi-Drop Connections . . . . .	52
Stacking Cabinets . . . . .	25	<b>4. Post-Installation Checkout</b> . . . . .	<b>54</b>
Stacking Modular Racks . . . . .	26	Applying Power . . . . .	54
Anti-Vibration/EMI Screws . . . . .	27	Verifying Proper Operation . . . . .	54
		Proceeding to Optimization . . . . .	56

# 1 PRE-INSTALLATION CONSIDERATIONS

A good installation is important to ensure the best possible performance and reliability of the station equipment. Vital to a good installation is pre-installation planning. Planning the installation includes considering the mounting location of the equipment in relation to input power, antenna(s), and telephone interfaces. Also to be considered are site environmental conditions, the particular mounting method (several available), and required tools and equipment. The following paragraphs provide additional details on these and other pre-installation considerations.

**Important**— If this is your first time installing this type of equipment, it is highly recommended that you completely read the entire Installation section before beginning the actual installation.

---

## Installation Overview

The following information is intended to serve as an overview for installing the *Quantar* station and ancillary equipment. Step-by-step procedures for each of the major tasks are then provided beginning in paragraph 2.

- Plan the installation, paying particular attention to environmental conditions at the site, ventilation requirements, and grounding and lightning protection.
- Unpack and inspect the equipment
- Mechanically install the equipment at the site
- Make necessary electrical and cabling connections, including the following:
  - AC input cabling
  - Coaxial cables to transmit and receive antennas
  - Phone line connections
  - System cables
- Perform a post-installation functional checkout test of the equipment to verify proper installation
- Proceed to the Optimization procedures (located behind the OPTIMIZATION tab) to customize the station parameters per customer specifications (e.g., operating frequency, PL codes, etc.)

---

## Environmental Conditions at Intended Installation Site

**Important** - If the station is to be installed in an environment which is unusually dusty or dirty (and thus does not meet the air quality requirements), the air used to cool the station modules must be treated using appropriate filtering devices. Dust, dirt or corrosive particulates accumulating on the internal circuit boards and modules is not easily removed, and can cause such malfunctions as overheating and/or intermittent electrical connections.

**Important** - The equipment should not be directly exposed to corrosive environments. Corrosive contaminants may come from local sources or the general atmosphere in the area of the radio equipment. A common source of corrosive contaminants comes from salt mist at a site located in a coastal environment. In such a case, proper air filtration for the site should be in place to protect the equipment from salt mist contamination.

The Quantar station may be installed in any location suitable for electronic communications equipment, provided that the environmental conditions do not exceed the equipment specifications for temperature, humidity, and air quality. These are:

Operating Temperature Range —  $-30^{\circ}\text{C}$  to  $+60^{\circ}\text{C}$

Humidity — not to exceed 95% relative humidity @  $50^{\circ}\text{C}$

Air Quality — For equipment operating in an environmentally controlled environment with the station cage(s) rack mounted, the airborne particulates level must not exceed  $25\ \mu\text{g}/\text{m}^3$

For equipment operating in an area which is not environmentally controlled (station cage(s) cabinet mounted), the airborne particulates level must not exceed  $90\ \mu\text{g}/\text{m}^3$

**Important!** Rack-mounted stations must be protected from dripping water from overhead pipes, air conditioning equipment, etc. Serious damage to station components could occur if proper protection is not provided.

---

## Equipment Ventilation

Two of the station modules (the power amplifier and power supply modules) are equipped with cooling fans (thermostatically controlled) that are used to provide forced convection cooling. The air flow is front to back, allowing several station cages to be stacked within a rack or cabinet. When planning the installation, observe the following ventilation guidelines:

- Customer-supplied cabinets must be equipped with ventilation slots or openings in the front (for air entry) and back or side panels (for air to exit). If several station cages are installed in a single cabinet, ensure ventilation openings surround **each** cage to allow for adequate cooling.
- All cabinets must have at least six inches of open space between the air vents and any walls or other cabinets. This allows adequate air flow.
- When multiple cabinets (each equipped with several station cages) are installed in an enclosed area, make sure the ambient temperature of the room does not exceed the recommended maximum operating temperature ( $+60^{\circ}\text{C}$ ). It may be necessary to have air conditioning or other climate control equipment installed to satisfy the environmental requirements.

## AC Input Power Requirements

**Note:** *If you wish to connect the station to a 220 VAC outlet, you must obtain a line cord employing "HAR" flexible cord with fittings approved by a safety testing agency in the end use country.*

The *Quantar* station is equipped with a multiple-output dc power supply module (various models available) that operates from 90Vrms to 280Vrms, 50 or 60 Hz ac input power (automatic range and line frequency selection). A standard 3-prong line cord is supplied to connect the power supply (rear of station) to the ac source.

It is recommended that a standard 3-wire grounded electrical outlet be used as the ac source. The outlet must be connected to an ac source capable of supplying a maximum of 766 Watts. For a nominal 110V ac input, the ac source must supply 8.5 amperes and should be protected by a circuit breaker rated at 15 amperes. For a nominal 220V ac input, the ac source must supply approximately 4.25 amperes.

## Equipment Mounting Methods

The *Quantar* station equipment may be mounted in a variety of racks and cabinets (available as options), as follows:

### No Rack or Cabinet

- Station shipped without rack or cabinet (Option X87AA) — customer may install station in rack or cabinet of choice; station is designed to fit standard EIA 19" rack configuration

### Standard Open Racks

- 7' (Model TRN7342), 7½' (Model TRN7343), or 8' (Model TRN7344) racks— open frame racks accept multiple *Quantar* stations and ancillary equipment; EIA 19" rack configuration. Note that rack mounting hardware (Option X153AA) is required for each *Quantar* cage to be rack mounted.

### Modular Racks

- 30" (Option X741AA), 45" (Option X742AA), or 60" (Option X743AA) modular racks — accept multiple *Quantar* stations and ancillary equipment; EIA 19" rack configuration. These racks are designed to be stacked (see page 26).

### Cabinets

- Shipped in 12" x 20" cabinet (Option X430AA) — roll-formed cabinet with front and rear vented doors holds a single *Quantar* station
- Shipped in 30" x 20" cabinet (Option X52AA) — roll-formed cabinet with front and rear vented doors holds up to three (3) *Quantar* stations
- Shipped in 46" x 20" cabinet (Option X308AA) — roll-formed cabinet with front and rear vented doors holds up to four (4) *Quantar* stations
- Shipped in 60" x 20" cabinet (Option X180AA) — roll-formed cabinet with front and rear vented doors holds up to six (6) *Quantar* stations

**Note:** *Although cabinets can physically house multiple stations, thermal limitations may reduce the maximum number of stations for a given cabinet size. Consult Motorola System Engineering or the Product System Planner if you anticipate possible thermal limitations.*

## Site Grounding and Lightning Protection



Proper site grounding and lightning protection are vitally important considerations. Failure to provide proper lightning protection may result in permanent damage to the radio equipment.

### **Site Grounding and Lightning Protection Recommendations**

One of the most important considerations when designing a communications site is the ground and lightning protection system. While proper grounding techniques and lightning protection are closely related, the general category of site grounding may be divided as follows:

**Electrical Ground** — Ground wires carrying electrical current from circuitry or equipment at the site is included in the category of electrical ground. Examples include the ac or dc electrical power used to source equipment located at the site, telephone lines, and wires or cables connected to alarms or sensors located at the site.

**RF Ground** — This type of ground is related to the transmission of radio-frequency energy to earth ground. An example of rf grounding is the use of shielding to prevent (or at least minimize) the leakage of unwanted rf transmissions from communications equipment and cables.

**Lightning Ground** — Providing adequate lightning protection is critical to a safe and reliable communications site. Telephone lines, rf transmission cables, and ac and dc power lines must all be protected to prevent lightning energy from entering the site building.

Although a comprehensive coverage of site grounding techniques and lightning protection is not within the scope of this instruction manual, there are several excellent industry sources for rules and guidelines on grounding and lightning protection at communications sites. Motorola recommends the following reference source:

*Standards and Guidelines for Communication Sites (R56)*      68P81089E50-A

### **Quantar Equipment Grounding Guidelines**

The *Quantar* station cage is equipped with a single ground lug located on the rear panel of the cage. Use this lug to connect the cage to the site ground point. It is assumed that all telephone lines, antenna cables, and ac or dc power cabling has been properly grounded and lightning protected by following the rules and guidelines provided in the previously mentioned reference source.

---

## Recommended Tools and Equipment

In addition to the typical complement of hand tools, the following tools and equipment are recommended for proper installation of the station equipment.

- A six to eight foot wooden step ladder (used to access the top of the 7', 7½', and 8' racks, if applicable)
- A block-and-tackle or suitable hoist is recommended to lift cabinets equipped with multiple stations, and to stack cabinets or modular racks. (Each fully equipped station cage weighs approximately 55 lbs.)
- Tarpaulin or plastic drop cloth to cover surrounding equipment while drilling concrete anchor holes (for installations where cabinet or rack is being anchored to concrete flooring)
- Vacuum cleaner for removing concrete dust (for installations where cabinet or rack is being anchored to concrete flooring)

---

## Equipment Unpacking and Inspection

The *Quantar* station equipment may be shipped either by air freight or electronic van (as specified by customer). The packing methods are as follows:

- If no cabinet or rack is selected, the station cage is shipped in a cardboard container with styrofoam interior corner braces.
- If the 12" x 20" cabinet is selected, the station cage is shipped installed in the cabinet, all contained within a cardboard container with corrugated interior corner braces.
- All other available cabinets are shipped with the *Quantar* station cage(s) installed in the cabinet, with the cabinet bolted to a wooden skid and covered with a cardboard box with corrugated interior corner braces
- Stations ordered for use in open frame racks (7', 7½', or 8' available) are shipped with the cage(s) in a cardboard container with corrugated interior corner braces. The rack is shipped separately wrapped in insulating foam.
- Stations ordered for use in a modular rack (30", 45", or 52" available) are shipped installed in the rack. The rack is then covered in an anti-static bag.

Thoroughly inspect the equipment as soon as possible after delivery. If any part of the equipment has been damaged in transit, immediately report the extent of the damage to the transportation company.

### Physical Dimensions and Clearances

#### Quantar Cage without Cabinet

Figure 1 shows the dimensions and recommended clearances for a single *Quantar* station cage.

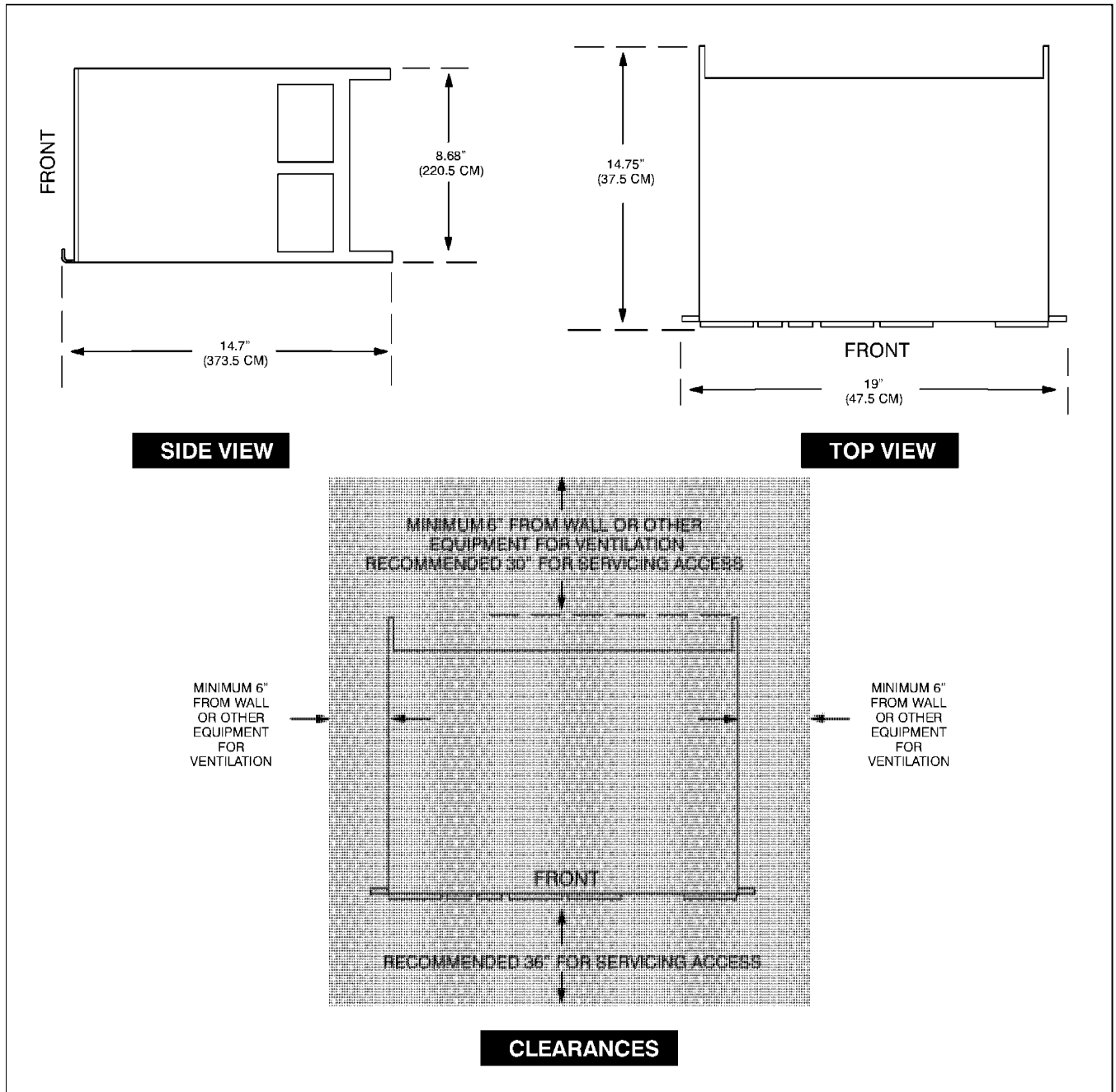

Figure 1. Quantar Station Cage Dimensions and Clearances

## Physical Dimensions and Clearances (Continued)

Model numbers for the three rack sizes are:

7'	TRN7342
7½'	TRN7343
8'	TRN7344

### Quantar Cages Installed in 7', 7½', and 8' Racks

Three sizes of racks are available for mounting *Quantar* station cages and ancillary equipment. Figure 2 shows the physical dimensions for all three rack sizes (shown is 8' rack with ten (maximum) *Quantar* cages installed; 7' and 7½' racks each hold nine maximum). Recommended clearance front and rear is 36" minimum for servicing access. Refer to Equipment Ventilation on Page 3 for recommended ventilation clearances.

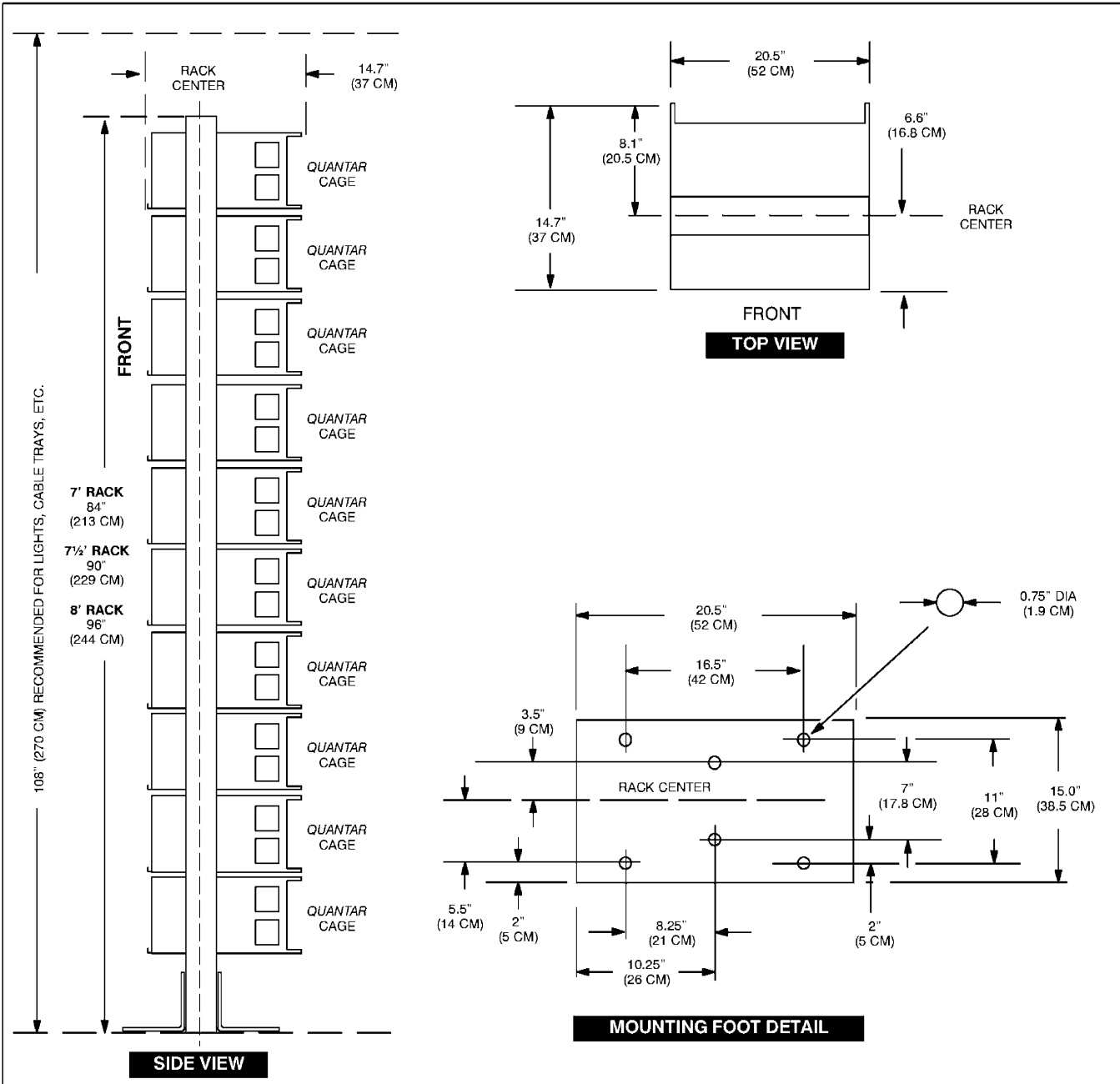

Figure 2. Dimensions and Clearances for 7', 7½', and 8' Racks



## Physical Dimensions and Clearances (Continued)

Option numbers for the three modular rack sizes for **Quantar** stations are:

- 30" X741AA
- 45" X742AA
- 52" X743AA

### Quantar Cages Installed in Modular Racks

Three sizes of modular racks are available for mounting *Quantar* station cages and ancillary equipment. Figure 3 shows the physical dimensions for all three rack sizes (shown is 52" modular rack with five (maximum) *Quantar* cages installed; 30" racks hold 3 cages and 45" racks hold 4 cages maximum). Recommended clearance front and rear is 36" minimum for servicing access. Refer to Equipment Ventilation on Page 3 for recommended ventilation clearances.

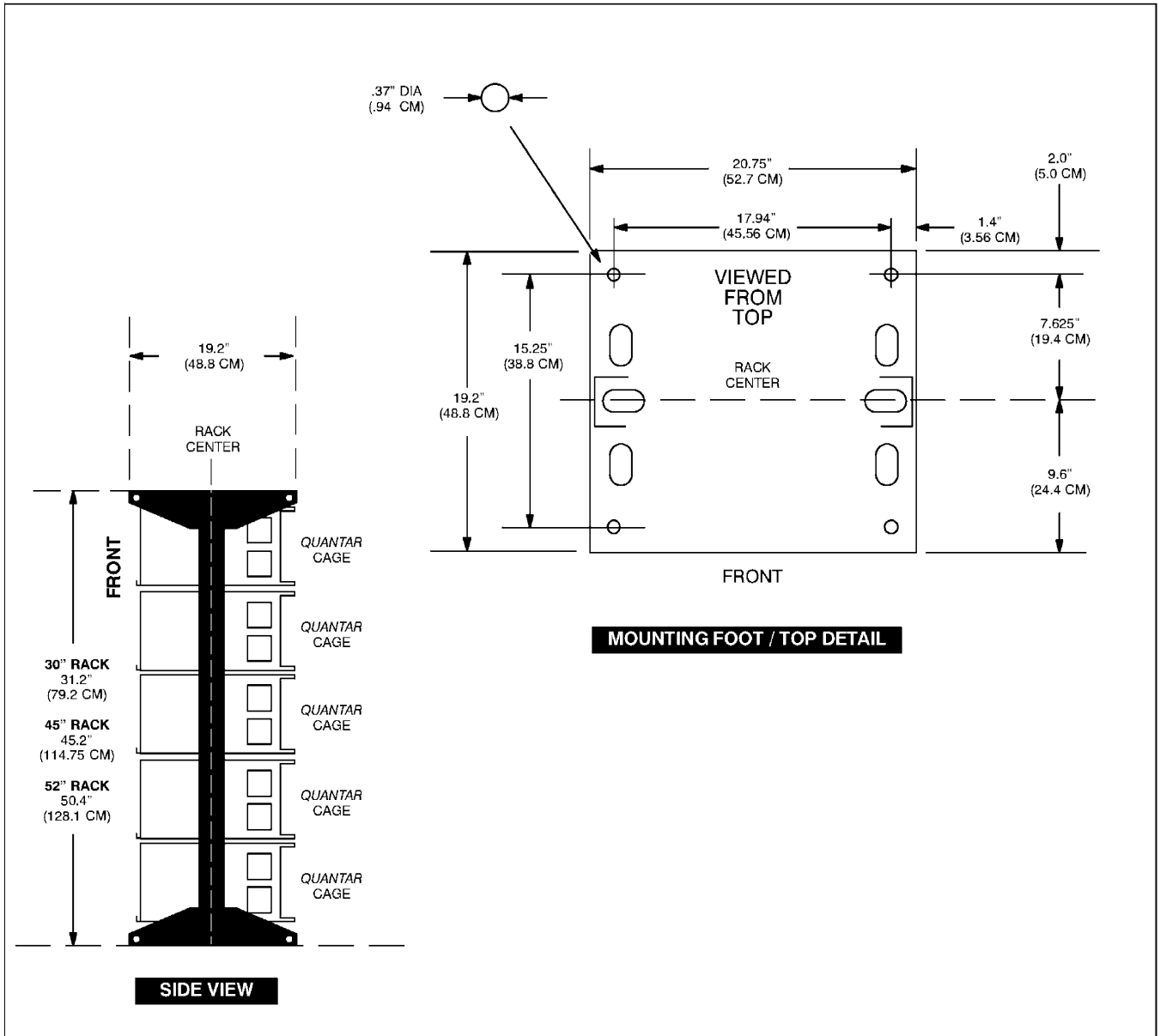
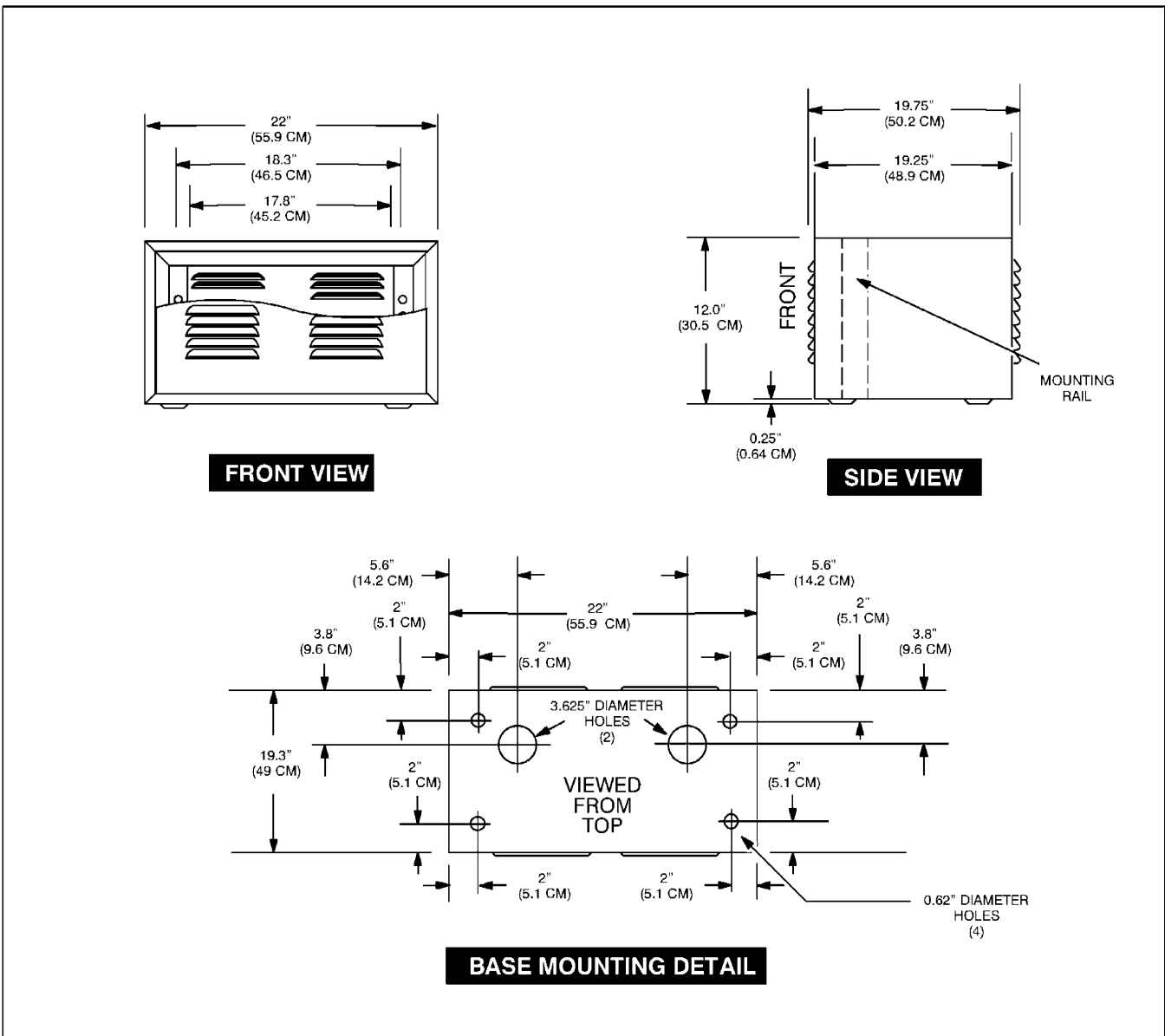

Figure 3. Dimensions and Clearances for 30", 45", and 52" Modular Racks

**Physical Dimensions and Clearances (Continued)**

**12" x 20" Cabinet**

Figure 4 shows the physical dimensions for a 12" x 20" cabinet (Option X430AA). Minimum recommended clearances are 30" (front) and 36" (rear) for installation access. Refer to Equipment Ventilation on Page 3 for recommended ventilation clearances.

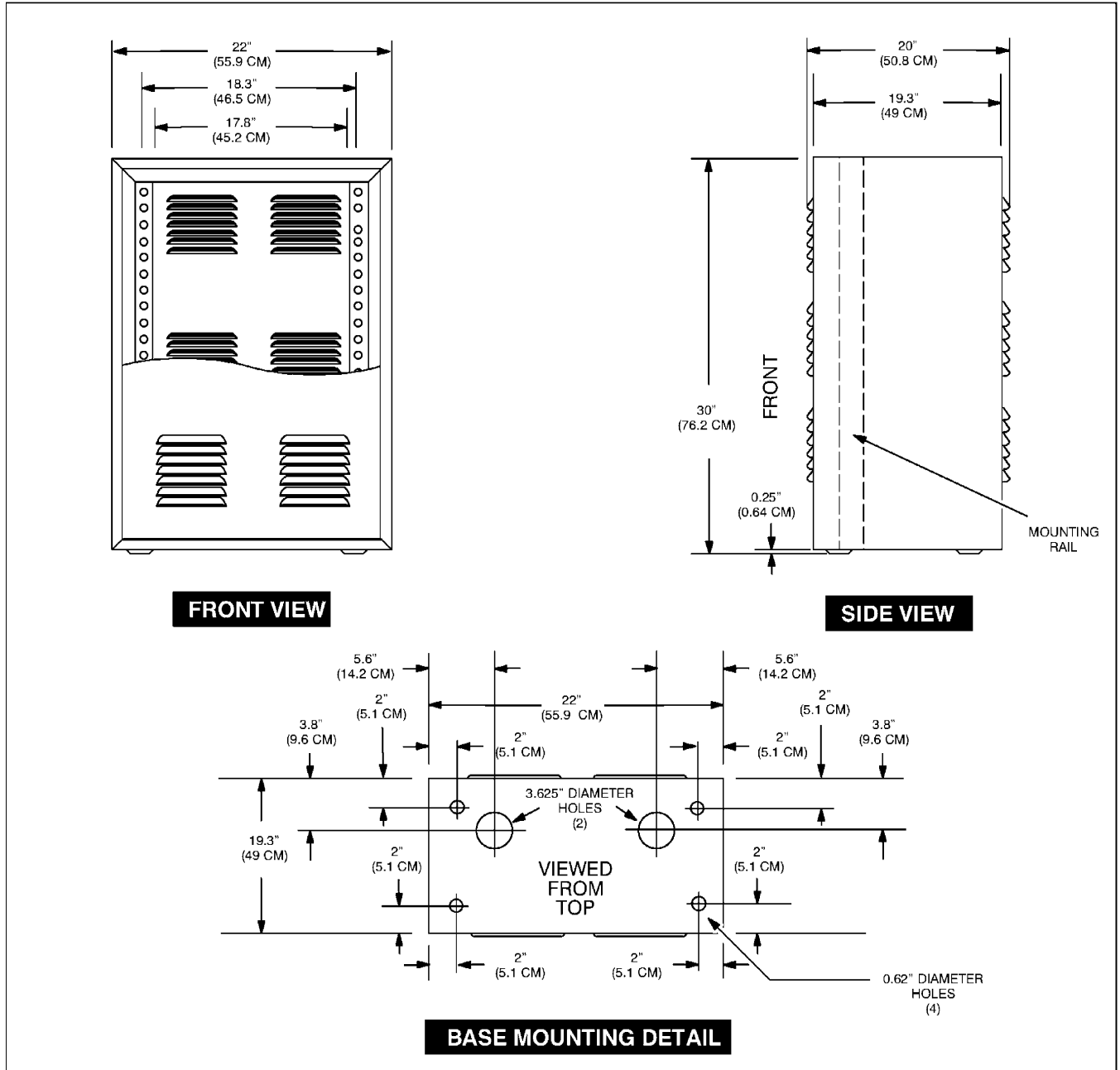

**Figure 4.** 12" x 20" Cabinet Dimensions

**Physical Dimensions and Clearances (Continued)**

**30" x 20" Cabinet**

Figure 5 shows the physical dimensions for a 30" x 20" cabinet (Option X52AA). Minimum recommended clearances are 30" (front) and 36" (rear) for installation access. Refer to Equipment Ventilation on Page 3 for recommended ventilation clearances.

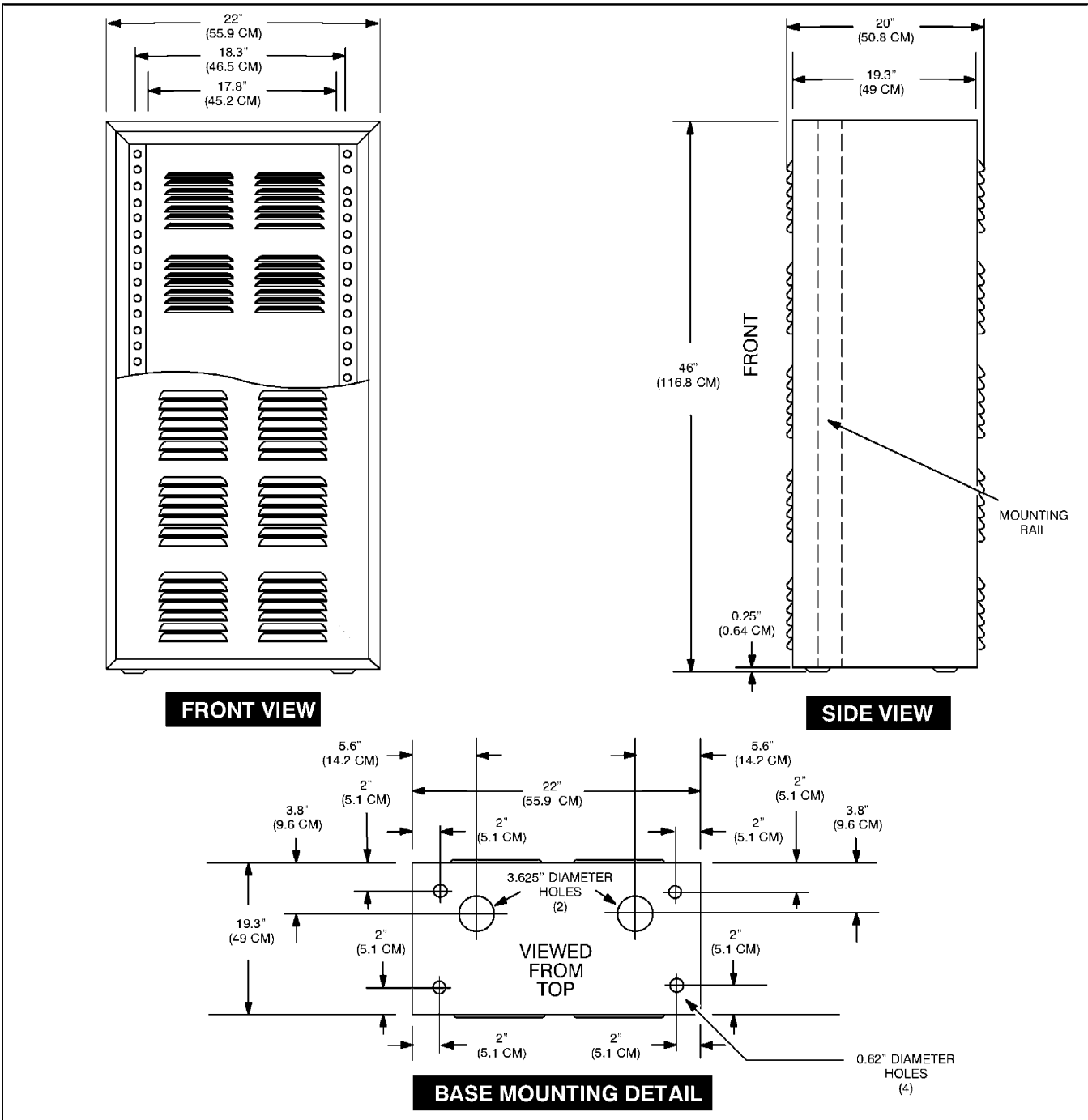

**Figure 5.** 30" x 20" Cabinet Dimensions

**Physical Dimensions and Clearances (Continued)**

**46" x 20" Cabinet**

Figure 6 shows the physical dimensions for a 46" x 20" cabinet (Option X308AA). Minimum recommended clearances are 30" (front) and 36" (rear) for installation access. Refer to Equipment Ventilation on Page 3 for recommended ventilation clearances.

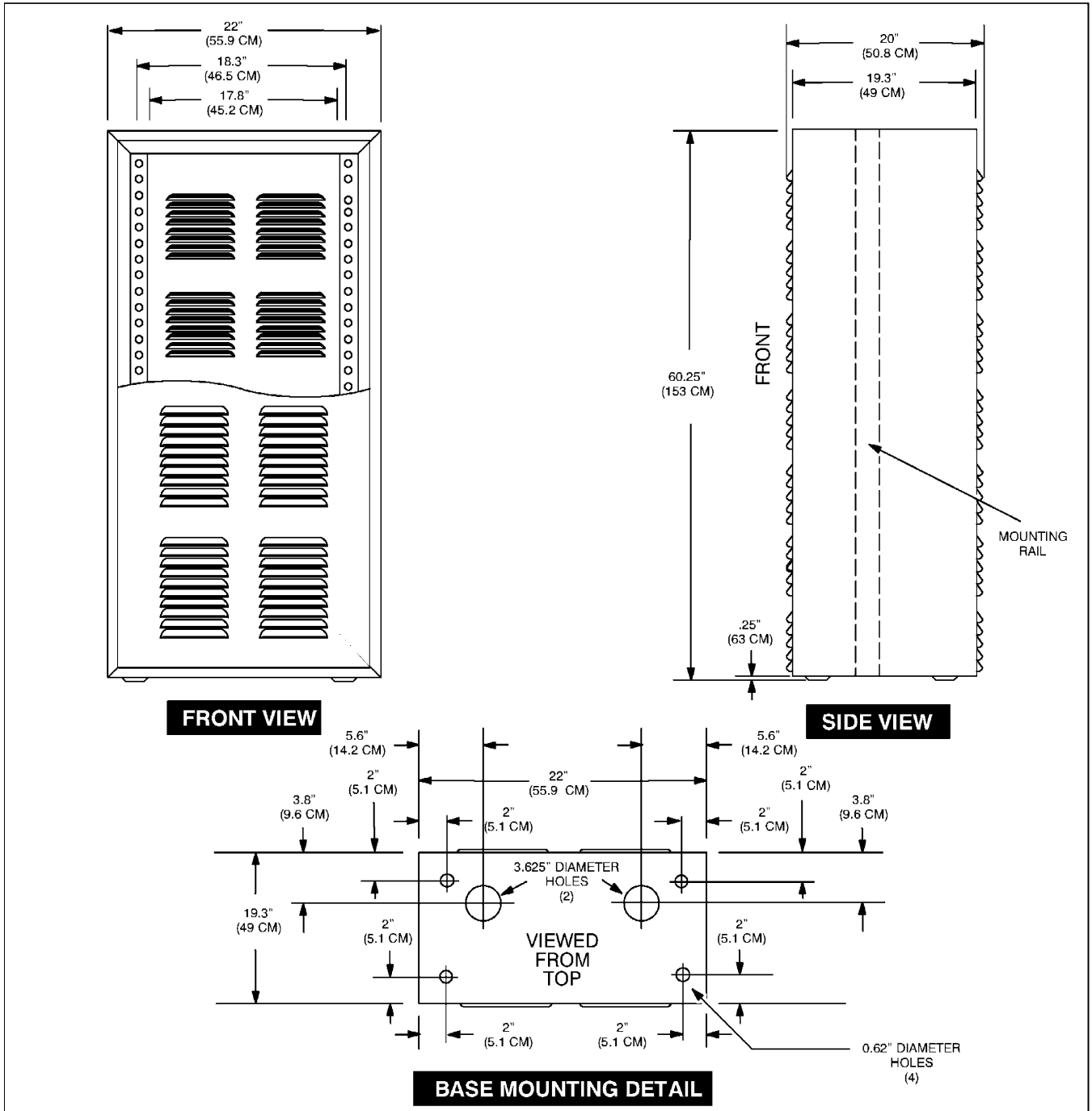

**Figure 6. 46" x 20" Cabinet Dimensions**

**Physical Dimensions and Clearances (Continued)**

**60" Indoor Cabinet**

Figure 7 shows the dimensions for a 60" indoor cabinet (Option X180AA). Minimum recommended clearances are 30" (front) and 36" (rear) for installation access. Refer to Equipment Ventilation on Page 3 for recommended ventilation clearances.



**Figure 7. 60" Indoor Cabinet Dimensions**

## 2 MECHANICAL INSTALLATION

This section describes the procedures necessary to unpack and mechanically install the *Quantar* station equipment. A variety of mounting methods are possible, depending on such factors as which type of cabinet or rack (if any) has been selected to house the station cage(s), whether stacking of cabinets is desired, etc. Procedures are provided for each of the cabinet/rack types.

If it becomes necessary to remove any of the modules, refer to the *Module Replacement Procedures* located in the **Troubleshooting** section of this manual for removal instructions. Be sure to observe proper electro–static discharge precautions if modules must be removed from the cage.

---

### Unpacking the Equipment

**Important:** *Regardless of the packing method, immediately inspect the equipment for damage after unpacking and report the extent of any damage to the transportation company.*

#### **Introduction**

*Quantar* station equipment packing methods vary depending upon the type of optional rack or cabinet selected by the customer. *Quantar* station cages may also be packed and shipped as standalone units with no cabinet or cage. Unpacking procedures for these various methods are provided in the following paragraphs.

#### **Unpacking Standalone Quantar Station Cage**

Standalone cages (ordered with Option X87AA, omit cabinet) are packed in a cardboard box with styrofoam interior spacers and cardboard stiffeners. Unpack as described in Figure 8.

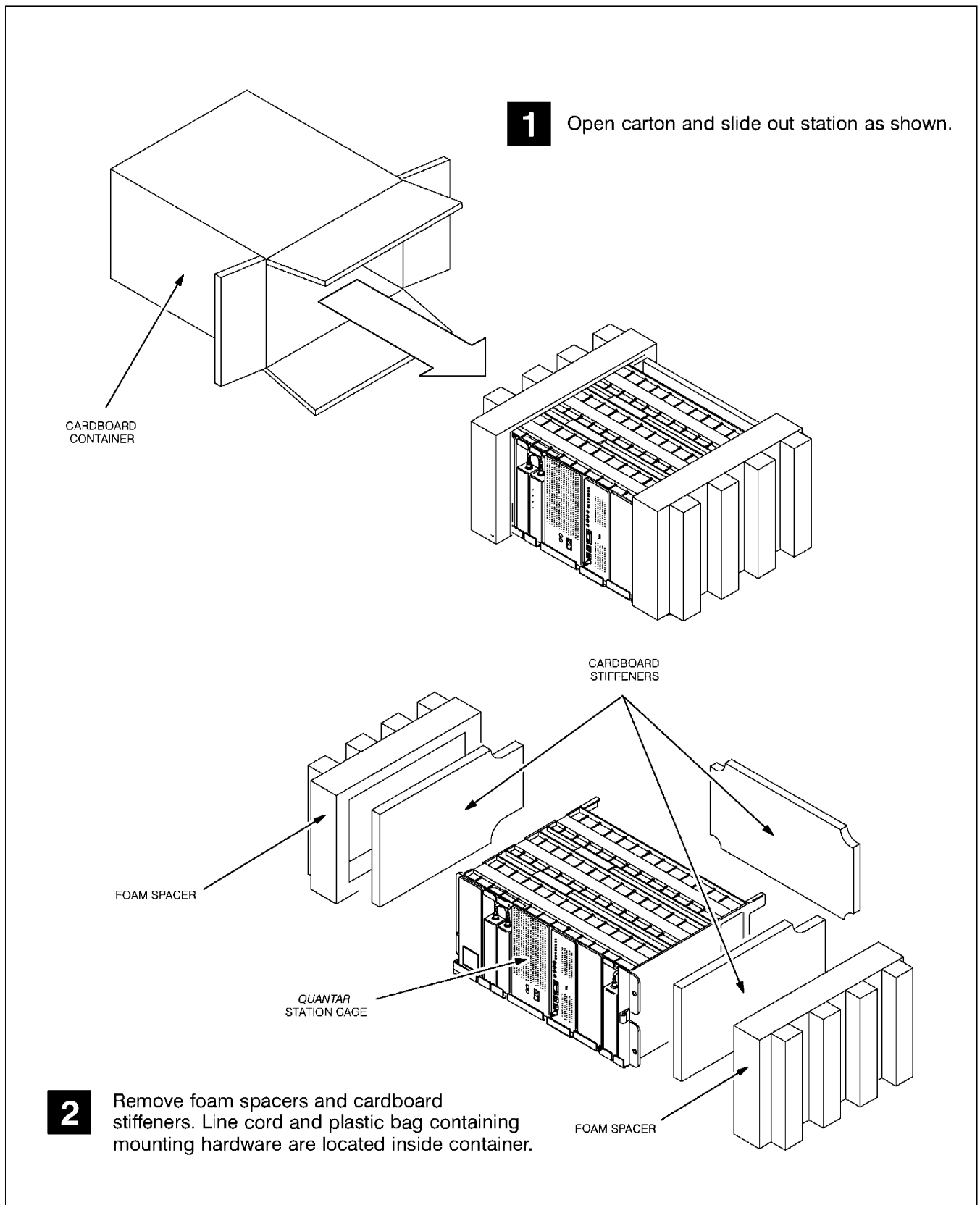

**Figure 8.** Unpacking Procedures for *Quantar* Station Cages

---

## Unpacking the Equipment (Continued)

### *Unpacking 12" x 20" Cabinet*

*Quantar* stations ordered with the 12" x 20" cabinet option are shipped installed in the cabinet and packed in a cardboard container with corrugated corner braces and a cardboard pallet. Unpack as described in Figure 9.



**1** Cut band at bottom of carton.

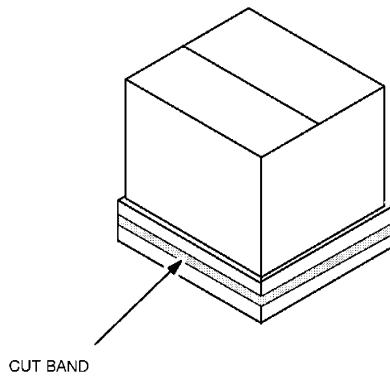

**2** Unfold cardboard flaps from cardboard pallet and remove cardboard cover.

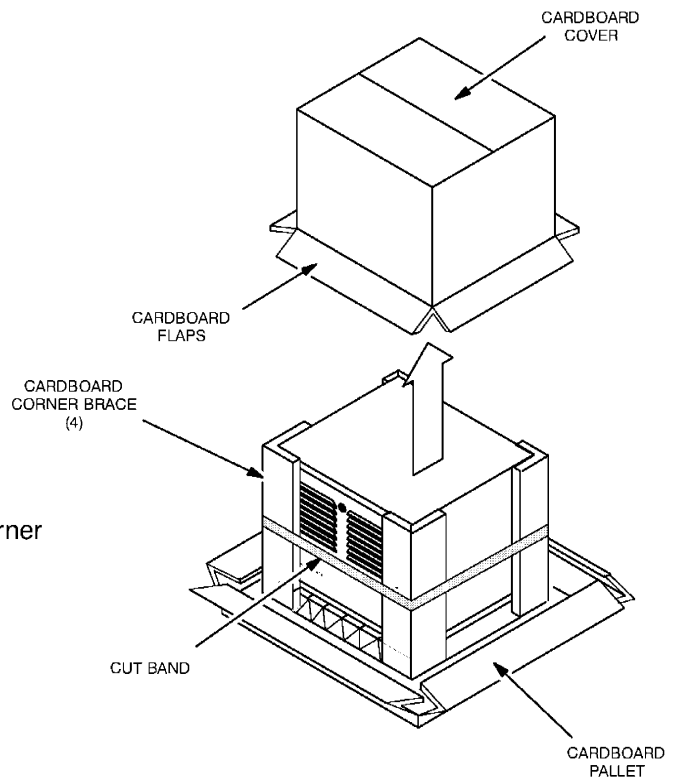

**3** Cut band and remove cardboard corner braces.

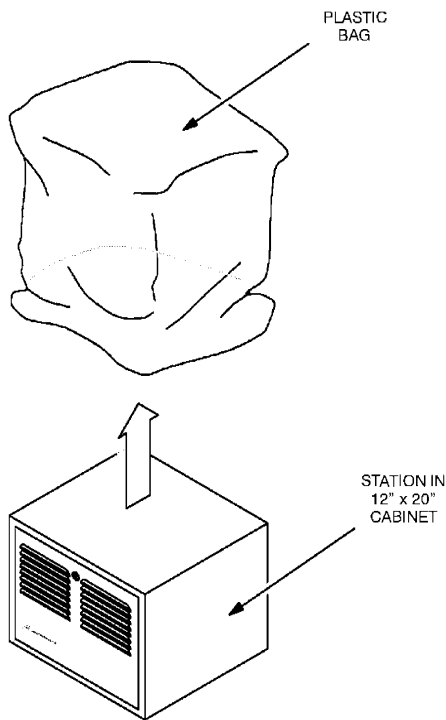

**4** Remove plastic bag.

**Figure 9.** Unpacking Procedures for *Quantar* Station Cages Shipped in 12" x 20" Cabinets

---

## Unpacking the Equipment (Continued)

### ***Unpacking 30" x 20" Cabinet, 46" x 20" Cabinet, and 60" Indoor Cabinet***

These cabinet styles are shipped mounted to a wooden skid, secured with corrugated corner braces held by a plastic strap, and covered with a cardboard cover. Unpack the equipment as described in Figure 10.

- 1** Remove cardboard cover from station.

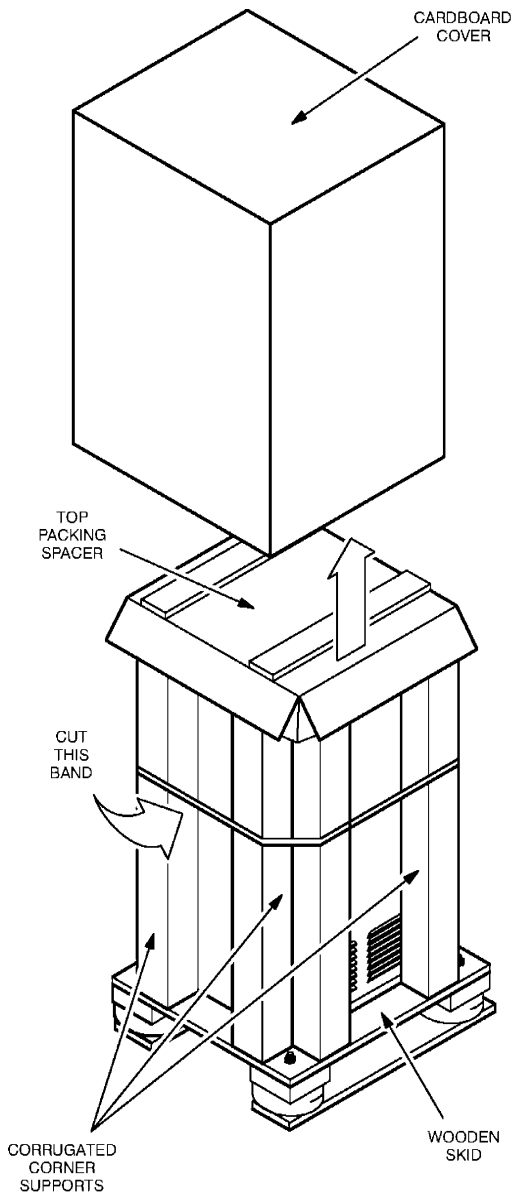

- 2** Cut band as shown.

- 3** Remove top packing spacer and corrugated corner supports.

- 4** Remove anti-static bag. **Do not** discard bag. It will be re-installed to protect equipment during installation.

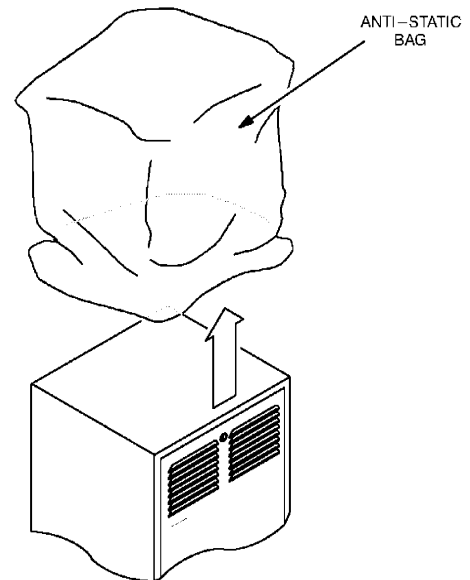

- 5** Depending on cabinet type, either open or remove front and rear doors to gain access to the four (4) bolts securing the station to the wooden skid. Remove the bolts and nuts as shown.

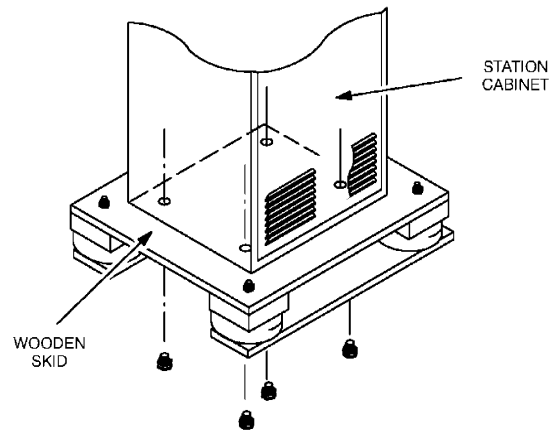

- 6** Use hoist to lift the station from the skid. Remove skid and return station to floor.

- 7** Replace anti-static bag over station to provide protection during installation.

**Figure 10.** Unpacking Procedures for 30", 46" (shown), and 60" Indoor *Quantar* Cabinets

---

## Mounting Procedures

### **Introduction**

Perform the following procedures to mechanically install the *Quantar* station equipment cages, racks, or cabinets. Note that racks and cabinets may house multiple *Quantar* station cages, and some cabinets may be stacked one atop the other to maximize use of space.

### **Mounting Quantar Station Cage(s) in Customer–Supplied Cabinet**

The *Quantar* station cage is designed to fit in a standard EIA 19” enclosure. Mounting screws (M6 x 1.0 tapping) are provided to secure the cage flanges to the customer–supplied cabinet. Mount the cage(s) as follows:

**Note:** *Installing multiple cages one above the other is permitted as long as proper ventilation is maintained. Refer to Equipment Ventilation on page 3 for details.*

- Step 1.** Determine the location in the cabinet into which to mount the cage. Note that when installing multiple cages, it is recommended that you mount the first cage in the lowest possible position in the cabinet, making sure the modules clear the bottom frame of the cabinet, then continue towards the top with additional cages.
- Step 2.** Thread two of the supplied mounting screws into the lowest mounting holes of the cabinet mounting rails. Now insert the cage into the cabinet, resting the cage on the two screws.
- Step 3.** Insert the remaining two mounting screws through the bottom two mounting holes in the cage mounting flanges (left and right sides) and secure the cage to the cabinet mounting rails.
- Step 4.** Remove the two lower mounting screws and insert them through the upper two mounting holes in the cage mounting flanges.
- Step 5.** Tighten all four mounting screws securely.

---

## Mounting Procedures (Continued)

**Note:** Option X153AA provides two (2) standoff brackets and four (4) self-tapping screws.

**Note:** Installing multiple cages one above the other is permitted as long as proper ventilation is maintained. Refer to Equipment Ventilation on page 3 for details.

### **Mounting Quantar Station Cage(s) in Customer–Supplied Rack**

Quantar station cages intended for field mounting in a customer–supplied rack require standoff brackets to center the cage within the rack mounting rails. Mount the cage(s) as described in Figure 11.

Note that when installing multiple cages, it is recommended that you mount the first cage in the lowest possible position in the rack, then continue building towards the top with additional cages. Mounting screws (M6 x 1.0 tapping) are provided with each cage to secure the cage flanges to the standoff brackets.

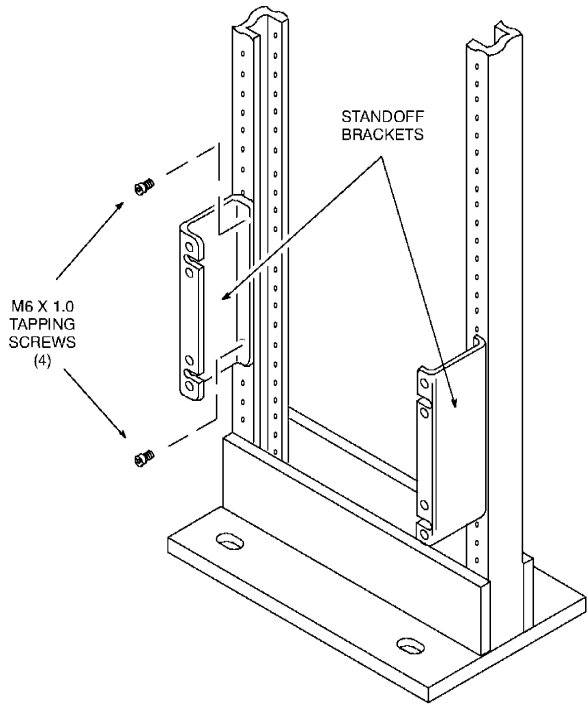

**1** Position standoff brackets at desired position on rack (as shown). Secure to rack using M6 x 1.0 tapping screws.

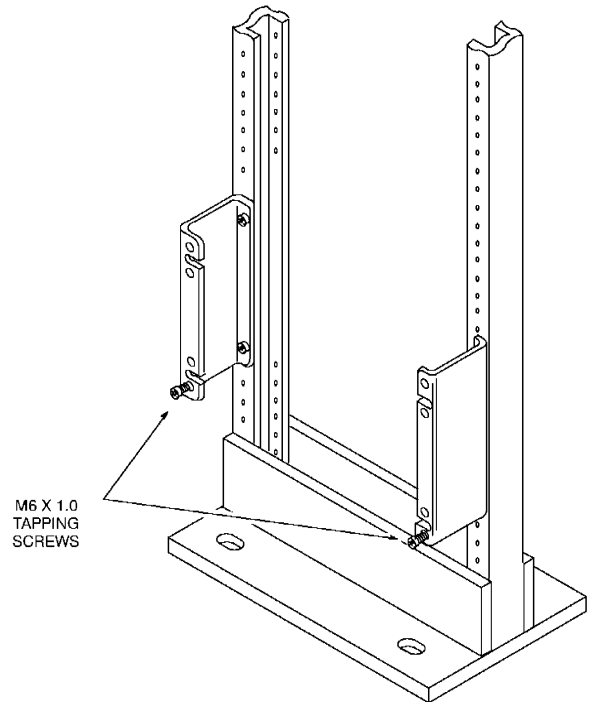

**2** Partially install M6 x 1.0 tapping screws in bottom holes in brackets, as shown.

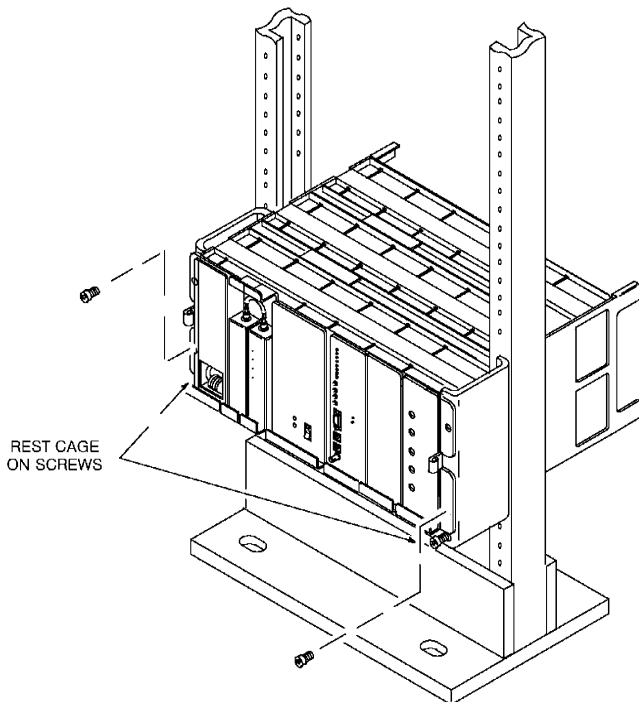

**3** Rest cage on lower two screws and install two M6 x 1.0 tapping screws in holes as shown. Tighten securely.

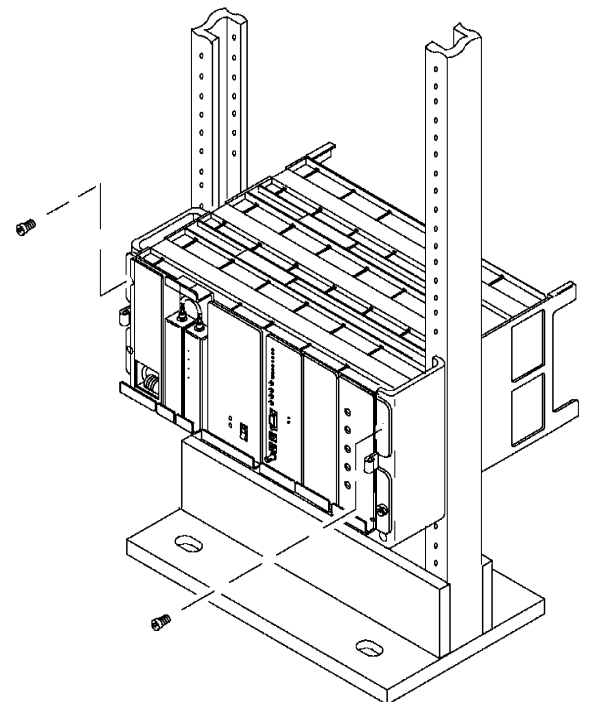

**4** Remove two screws used to support cage and install in the upper two holes of the brackets. Tighten securely.

**Figure 11.** Installation Procedure for Rack Standoff Brackets

## Mounting Procedures (Continued)



### WARNING

A fully equipped 8' rack (ten *Quantar* cages) weighs approximately 650 lbs (245 kg). Handle with extreme caution to avoid tipping.



### CAUTION

Cement dust from concrete flooring is harmful to electronic equipment and wiring. Make sure that the rack and any co-located equipment are protected prior to drilling holes in the concrete floor. Use a tarpaulin, cloth, or plastic sheeting to cover exposed equipment. (The rack should be already covered with an anti-static bag; do not remove the bag at this time.) Use a vacuum while drilling the holes to minimize the spread of concrete dust. Carefully clean up any accumulated dust and debris from the anchor installation before uncovering the equipment.

### **Installing 7', 7½', and 8' Open Racks and 30", 45", and 52" Modular Racks**

In a typical installation, the rack is bolted to a concrete floor to provide stability. The following procedure describes the steps necessary to bolt the rack to a concrete floor. Be sure to check with local authorities to verify that the following procedure conforms to local building codes and regulations **before permanently installing the rack**.

- Step 1.** Carefully align the rack at the desired anchoring location.
- Step 2.** Use the rack mounting foot as a template and mark the location of the six (open racks) ¾" (1.9 cm) or four (modular racks) .37" (.94 cm) diameter mounting holes. All four or six anchoring positions must be used.
- Step 3.** Move the rack aside, drill holes in the concrete floor, and install the mounting anchors (RAM RD-56 anchors recommended) per instructions provided with the anchors. Make sure that none of the anchors comes in contact with the reinforcing wire mesh buried in the concrete; the rack must be electrically isolated from any other equipment or materials at the site.
- Step 4.** Align the rack with the installed anchors and lightly secure the rack to the floor using the proper mounting hardware. **Do not tighten the mounting hardware at this time.**
- Step 5.** Check the vertical plumb of the rack. Also check that the top is level. Use shims (flat washers or flat aluminum plates) as necessary under the rack mounting foot to achieve vertical plumb and horizontal level.
- Step 6.** Tightly secure the rack to the floor anchors making sure that it remains vertically plumb and horizontally level.
- Step 7.** After all debris is removed and cement dust is cleared away, remove whatever protective covering has been placed on the equipment, including the anti-static bag.

### **Mounting 30" x 20", 46" x 20", and 60" Indoor Cabinets**

Each cabinet bottom is pre-drilled with four (4) mounting holes to allow attachment to the site floor. If installing on a concrete floor, use the cabinet as a template, mark the hole locations, and follow the procedures given for anchoring equipment racks (page 24). If installing on a wooden floor, use lag bolts and washers (customer supplied) to secure the cabinet to the floor.

## Stacking Cabinets

The 12", 30", 46", and 60" cabinets may be stacked on atop another to maximize use of site space. Stacking kit TRN7750A contains the necessary bolts, nuts, and washers to stack one cabinet on another. Remove the knockouts on the top of the lower cabinet and use the hardware as shown below to attach the upper cabinet.

**Note:** It is recommended that if different sizes of cabinets are being stacked (e.g., if a 30" cabinet is being stacked on top of a 46" cabinet), the larger size cabinet should be placed on the bottom.

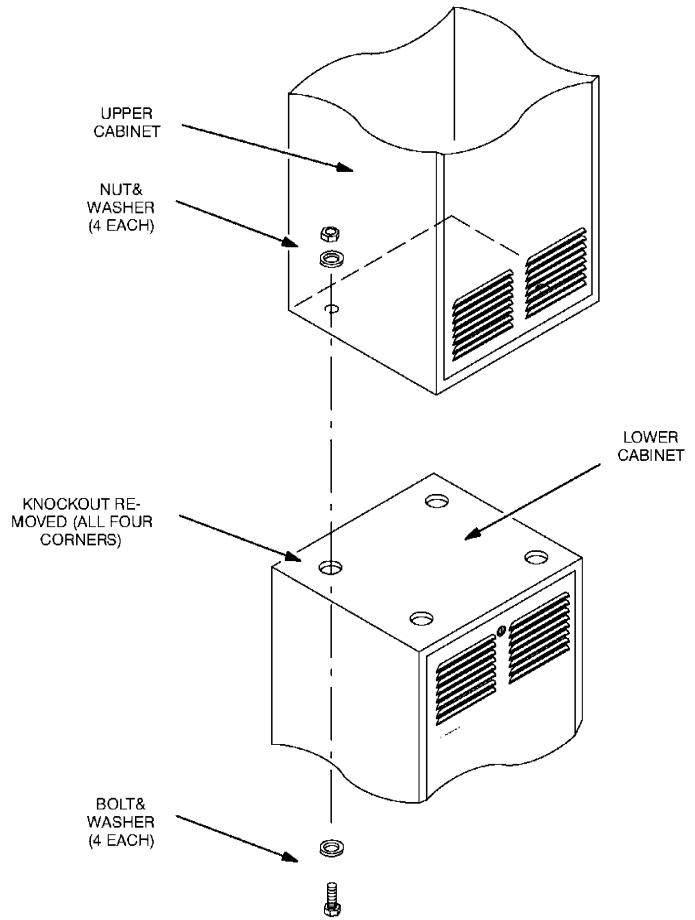

The table below lists the stacking limits for the available cabinet sizes.

### Cabinet Stacking Limits

Cabinet Size	Maximum Stacking Number
12" x 20"	6 (72" max height)
30" x 20"	3 (90" max height)
46" x 20"	2 (92" max height)
60" Indoor	Not Stackable



## Stacking Modular Racks

**Note:** It is recommended that if different sizes of racks are being stacked (e.g., if a 30" rack and a 45" rack are being stacked), the larger rack should be placed on the bottom.

**Note:** Lift Brackets are available from WASPD to aid in lifting the racks. Install the brackets as shown below, and attach a lift bar or chain thru the bracket holes. A hoist may then be used to lift the rack.

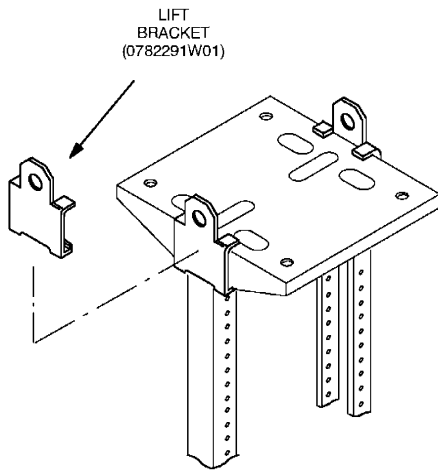

The 30", 45", and 52" modular racks may be stacked one atop another to maximize use of site space. Stacking kit TRN7750A contains the necessary bolts, nuts, and washers to stack one rack on another. Use the hardware as shown below to attach the upper rack.

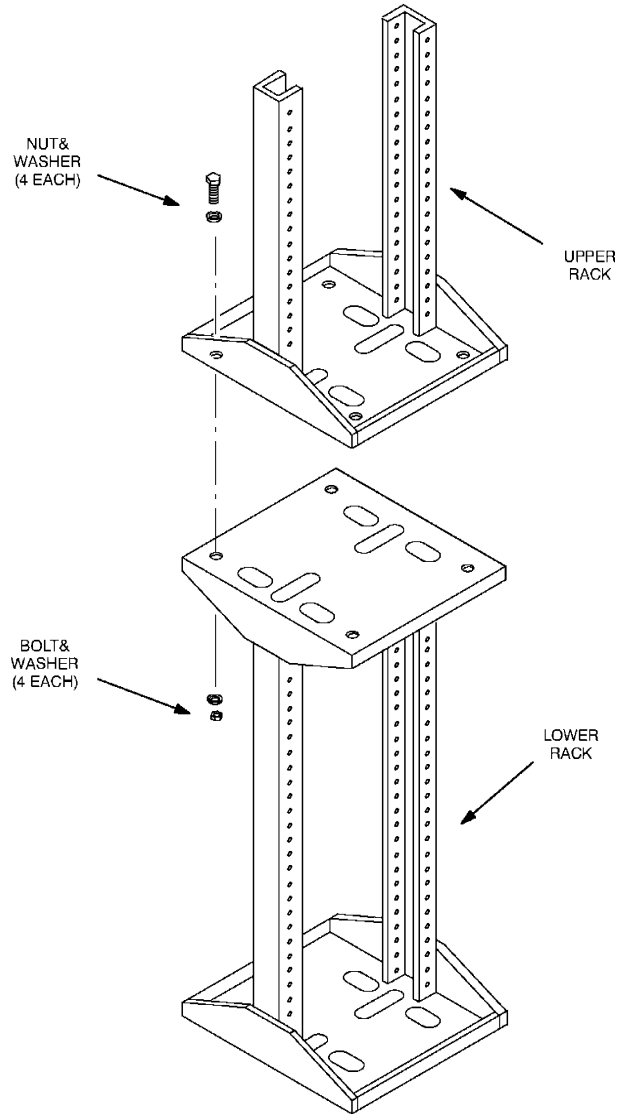

### Modular Rack Stacking Limits

Stacking Combinations
Three 30" Modular Racks
One 45" and One 30" Modular Rack
One 30" and One 52" Modular Rack
Two 45" Modular Racks
One 45" and One 52" Modular Rack

## Anti-Vibration/EMI Screws

Stations are shipped with Torx-head tapping screws installed at the top and bottom of each of the module front panels. These screws help reduce EMI emissions from the station modules, as well as provide additional mechanical stability for installations where a high amount of vibration (such as from nearby heavy machinery) is encountered.

ANTI-VIBRATION SCREW  
(SHOWN INSTALLED IN  
RECEIVER MODULE)

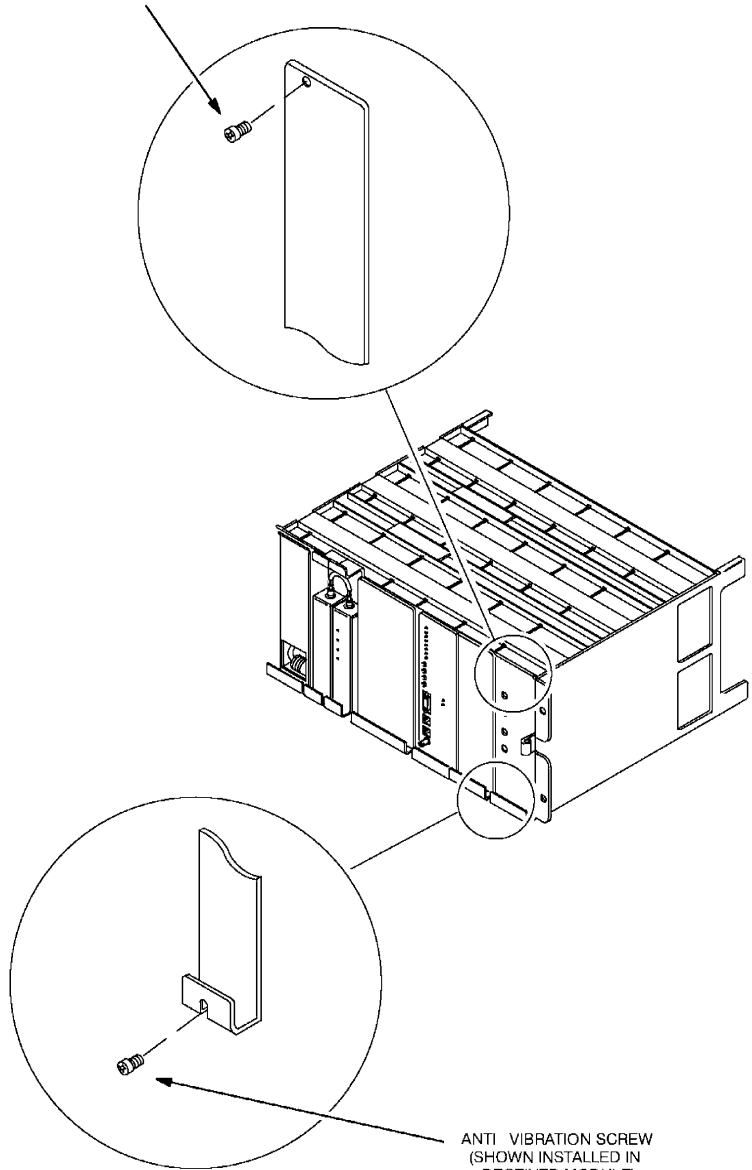

ANTI VIBRATION SCREW  
(SHOWN INSTALLED IN  
RECEIVER MODULE)

### 3 ELECTRICAL CONNECTIONS

After the station equipment has been mechanically installed, electrical connections must be made. These include making power supply connections, connecting antenna coax cables, system cables, and telephone lines.

#### Power Supply Connections



**CAUTION**

**Do not** apply ac power to the station at this time. Make sure that the ac power switch (located on the front panel of the Power Supply Module) is turned to OFF and that the circuit breaker associated with the ac outlet is also turned to OFF.

#### AC Input Power Connection

Each station cage is shipped with an eight foot 3-conductor line cord. Attach the receptacle end of the cord to the ac input plug located on the rear of the power supply module (as shown in Figure 12). Plug the 3-prong plug into a 110 V ac grounded outlet. (If you wish to connect the station to a 220 V ac outlet, you must obtain a line cord employing "HAR" flexible cord with fittings approved by a safety testing agency in the end use country.)

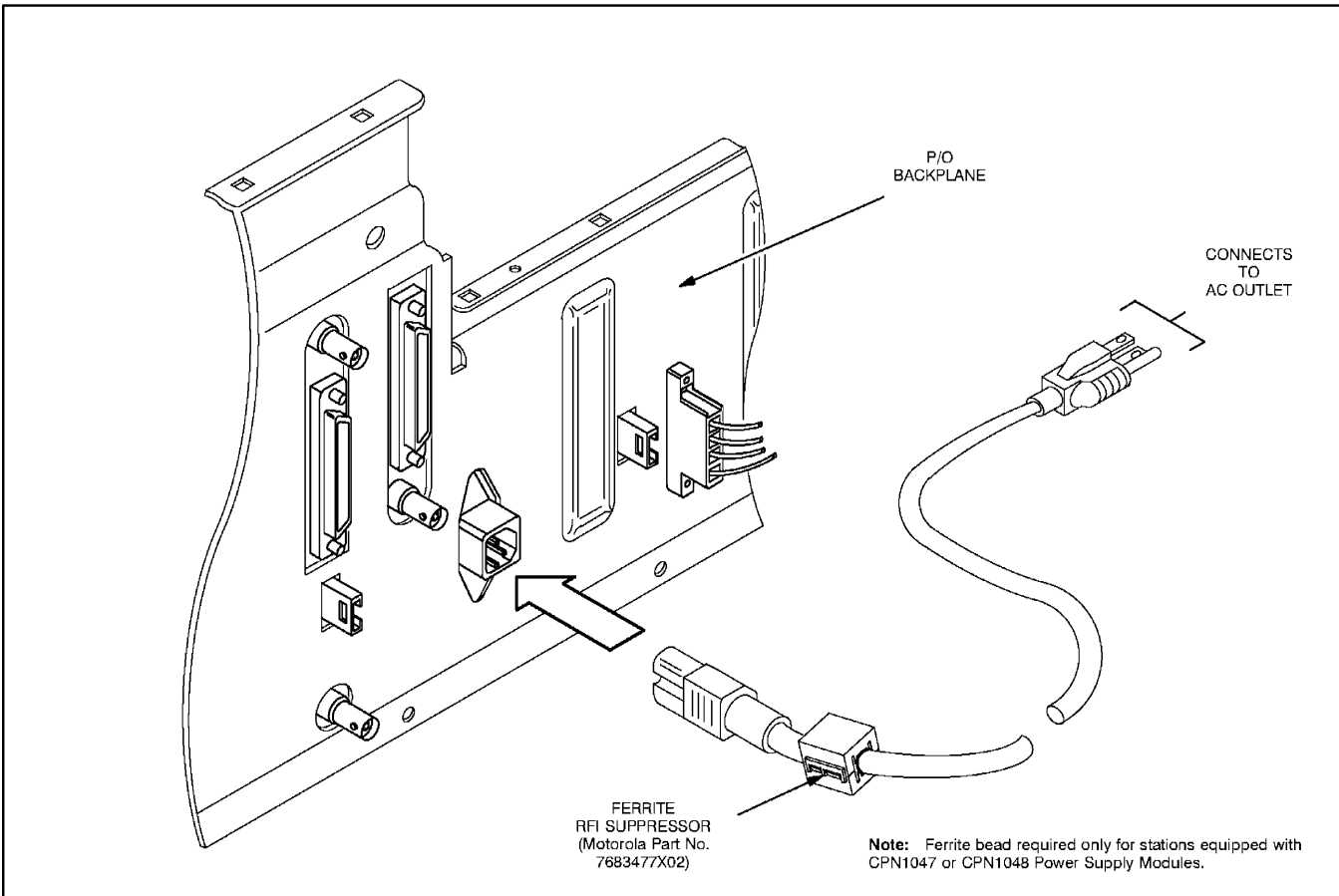

Figure 12. Connecting AC Line Cord

## Power Supply Connections (Continued)

### DC Input Power Connections

Stations shipped with the optional dc input power supply module accept a dc input from either a 12/24 V dc or 48/60 V dc source (e.g., a bank of storage batteries). Connections to the dc source are made via a 10' battery charger cable kit shipped with the station, as shown in Figure 13.

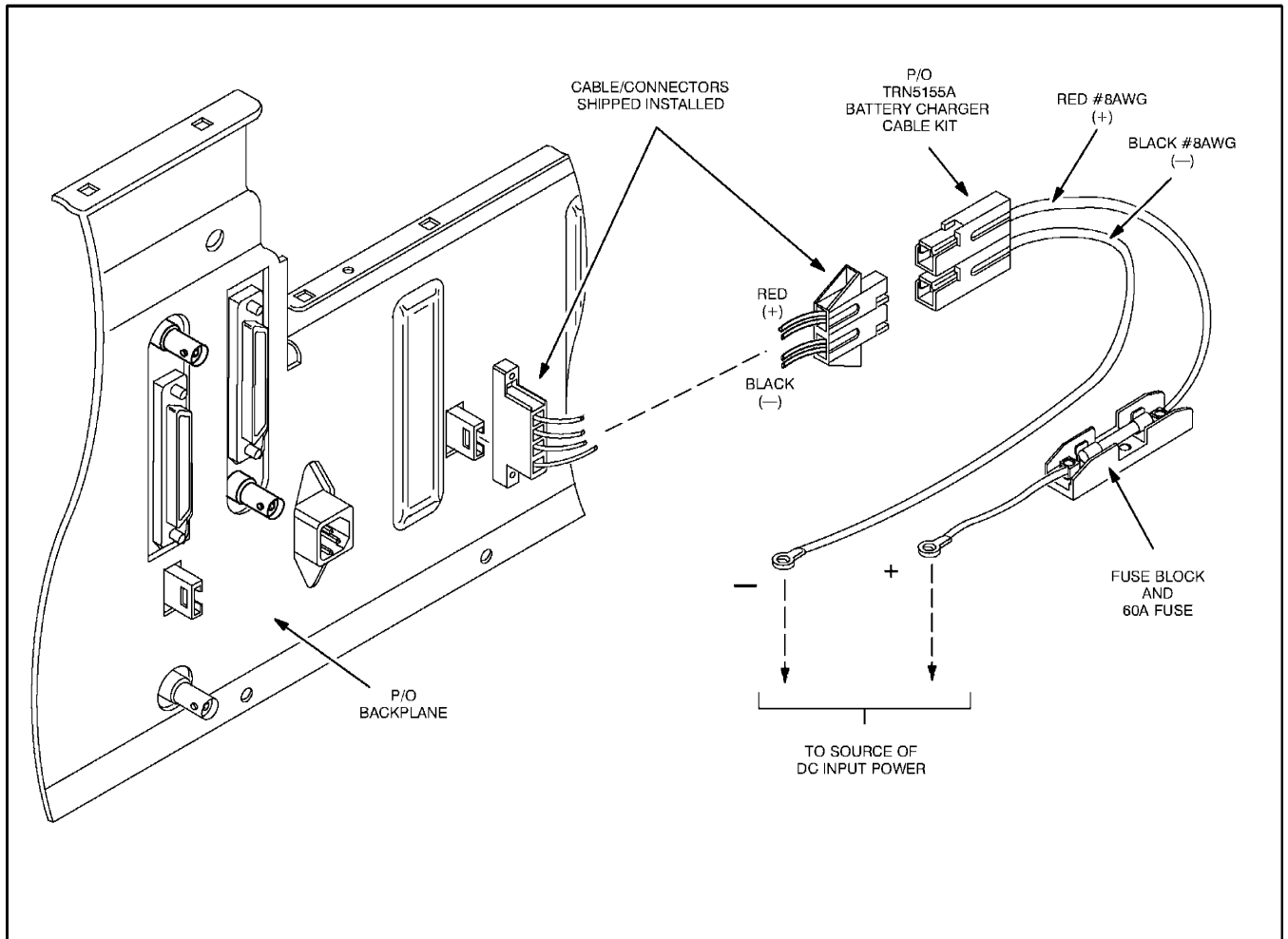

Figure 13. Making Connections to DC Power Source

## Power Supply Connections (Continued)

### Ground Connection

The *Quantar* station cage is equipped with a single ground lug located on the rear panel of the cage. Connect this lug to the site ground point as shown in Figure 14, and tighten the nut on the ground stud to 60 in-lbs (6.6 N-m).

Refer to *Standards and Guidelines for Communication Sites (R56) 68P81089E50-A* for complete information regarding lightning protection.

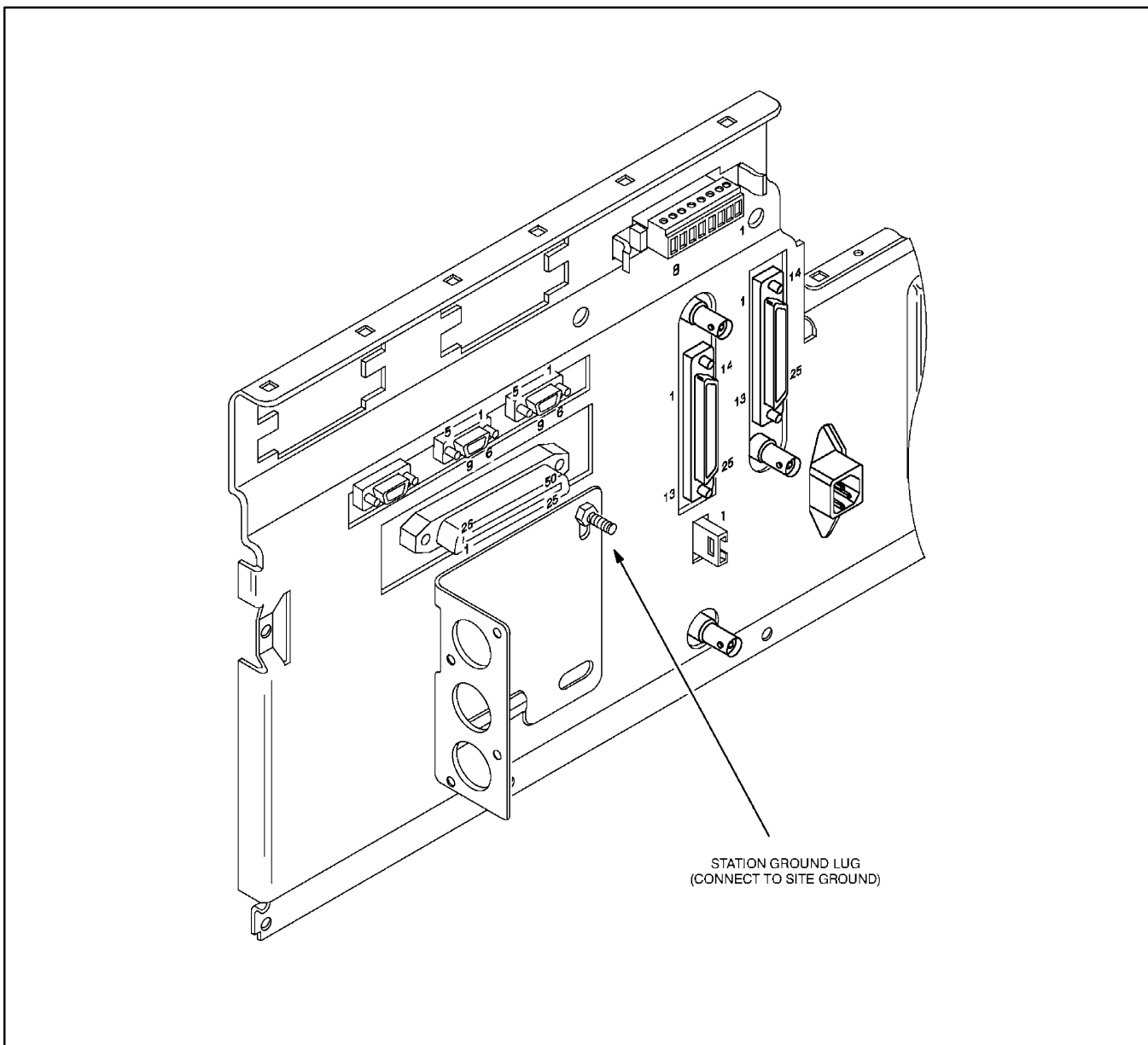

**Figure 14.** Connecting Station Ground Lug to Site Ground

## Power Supply Connections (Continued)

**Important!** Connect the charged battery to the station **before** applying AC power. Failure to do so may prevent the Power Supply Module from reverting to battery power upon AC failure.

**Important!** For Motorola Power Supply Modules with battery charging capability, the card edge connector used to connect to an external battery (located on the backplane) **may not** be used as a secondary source of dc output power. In order to prevent charging a battery with one or more dead cells, the supply is designed to provide charging current only if the battery is above +21.5 V (High Power Supplies) or +10.5 V (Low Power Supplies).

**Important!** Be sure to connect the battery cables **exactly** as shown in the illustration below, making certain to observe wire colors and polarities.

## Storage Battery Connections

Stations with a power supply module equipped with the battery charger/revert option offer the capability of reverting to battery backup power in the event of an ac power failure. Connections associated with the battery charger/revert feature are:

- **Charger/Revert Cable** — the station is shipped with a 4-wire cable terminated in a heavy duty 2-position connector; cable kit TRN5155A (shipped with station) contains mating connector, two 10' lengths of red and black #8 AWG gauge wires, a fuse block and 60A fuse, and crimp-on ring lugs. Make connections to the storage battery as shown in Figure 15.
- **Battery Temperature Cable** — thermistor (TKN8786A) and cable (TKN8732A) are shipped with charger-style power supply); cable with three wires carries a variable resistance signal from the thermistor which is mounted in close proximity to storage battery; resistance is proportional to battery temperature and is used by diagnostic circuitry in power supply module. Make thermistor connections as shown in Figure 15.

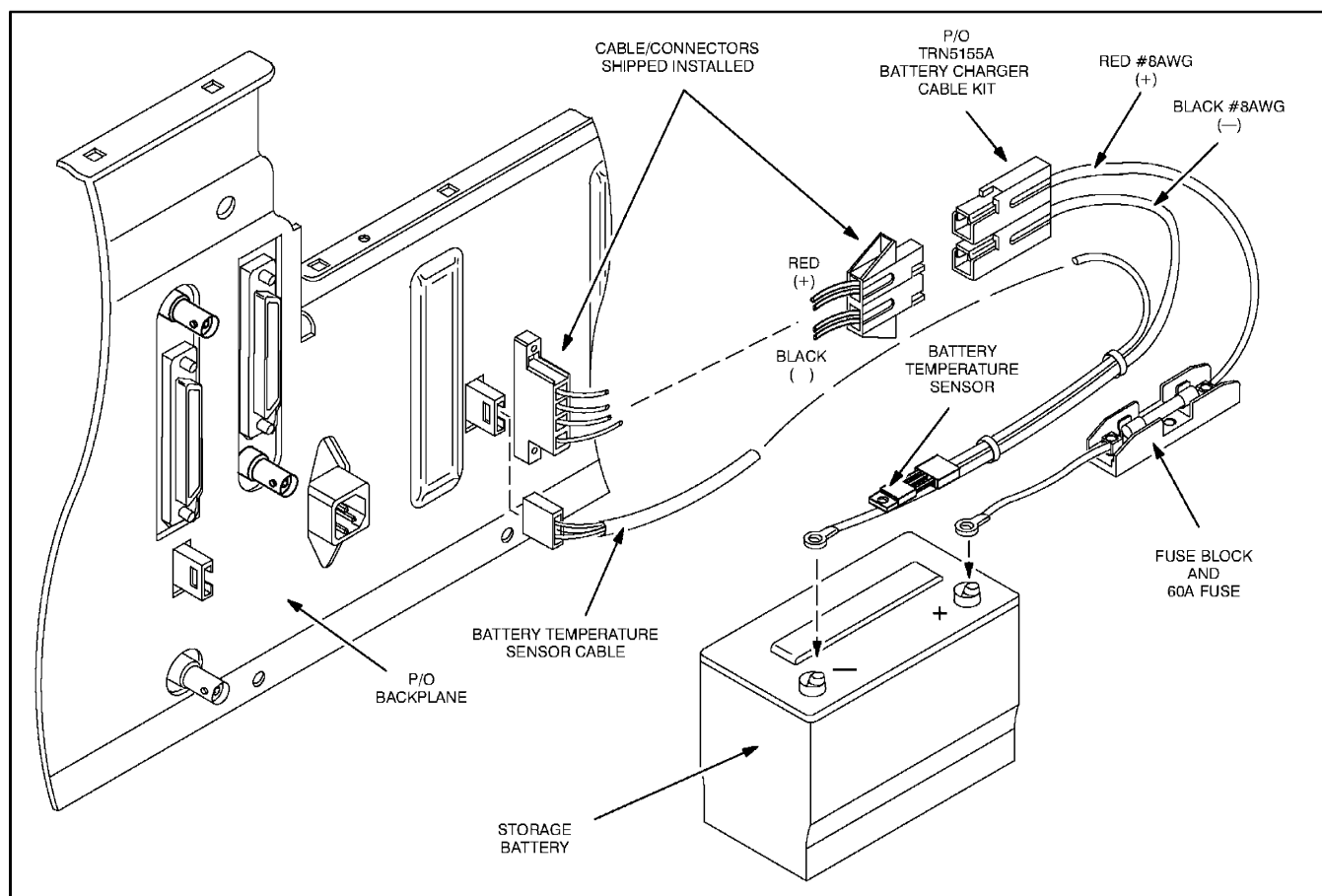

**Figure 15.** Making Connections to Storage Battery

---

## RF Cabling Connections

### *Introduction*

The transmit and receive antenna rf connections may be made in one of three fashions, depending on the options ordered with the station and system application.

- **Separate TX and RX Connectors** — A bracket located on the rear of the station holds two N-type connectors, one for RX and one for TX. Coax cables from the receive and transmit antennas must be connected to these N-type connectors.
- **Single Antenna with Antenna Relay Option**— An antenna relay module is mounted on the rear of the station. Coax cables from the station Receiver and Power Amplifier Modules are connected to the antenna relay module. A single N-type connector is provided for connection to a single RX/TX antenna. The relay module is controlled by a signal from the Station Control Module via a 3-wire cable connected between the antenna relay module and a 3-pin connector located on the backplane.
- **Duplexer Option** — The duplexer option equips the station with a Duplexer Module which is typically mounted in the same rack or cabinet as the station. Coax cables from the station Receiver and Power Amplifier Modules are connected to the Duplexer Module. A single N-type connector is provided for connection to a single RX/TX antenna.

## RF Cabling Connections (Continued)

### Separate RX and TX Connectors

Stations intended for separate transmit and receive antennas are shipped with the coax cables from the Power Amplifier and Receiver Modules connected to the bracket on the backplane, as shown below (Figure 16).

Connect the rf cables from the transmit and receive antennas to the station as shown below.

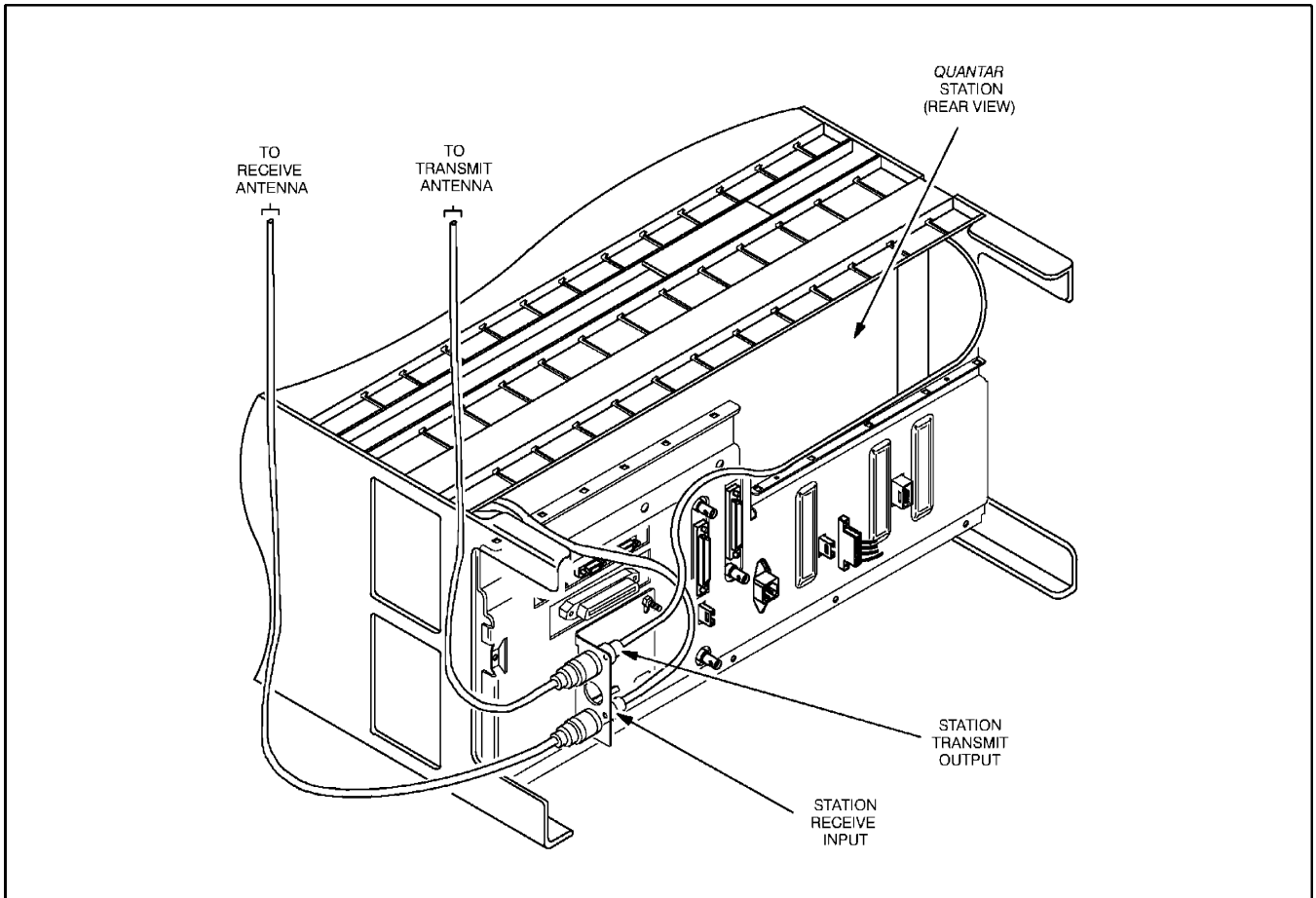

**Figure 16.** Separate RX and TX Antenna Connections



## RF Cabling Connections (Continued)

### Antenna Relay Option

Stations equipped with the antenna relay option are shipped with the antenna relay module installed in the bracket on the backplane, with the rf cables from the Power Amplifier and Receiver Modules connected as shown below (Figure 17). Note that the 3-wire control cable from the antenna relay to connector #23 located on the backplane has been installed.

Connect the single transmit/receive antenna rf cable to the center N-type connector on the antenna relay module.

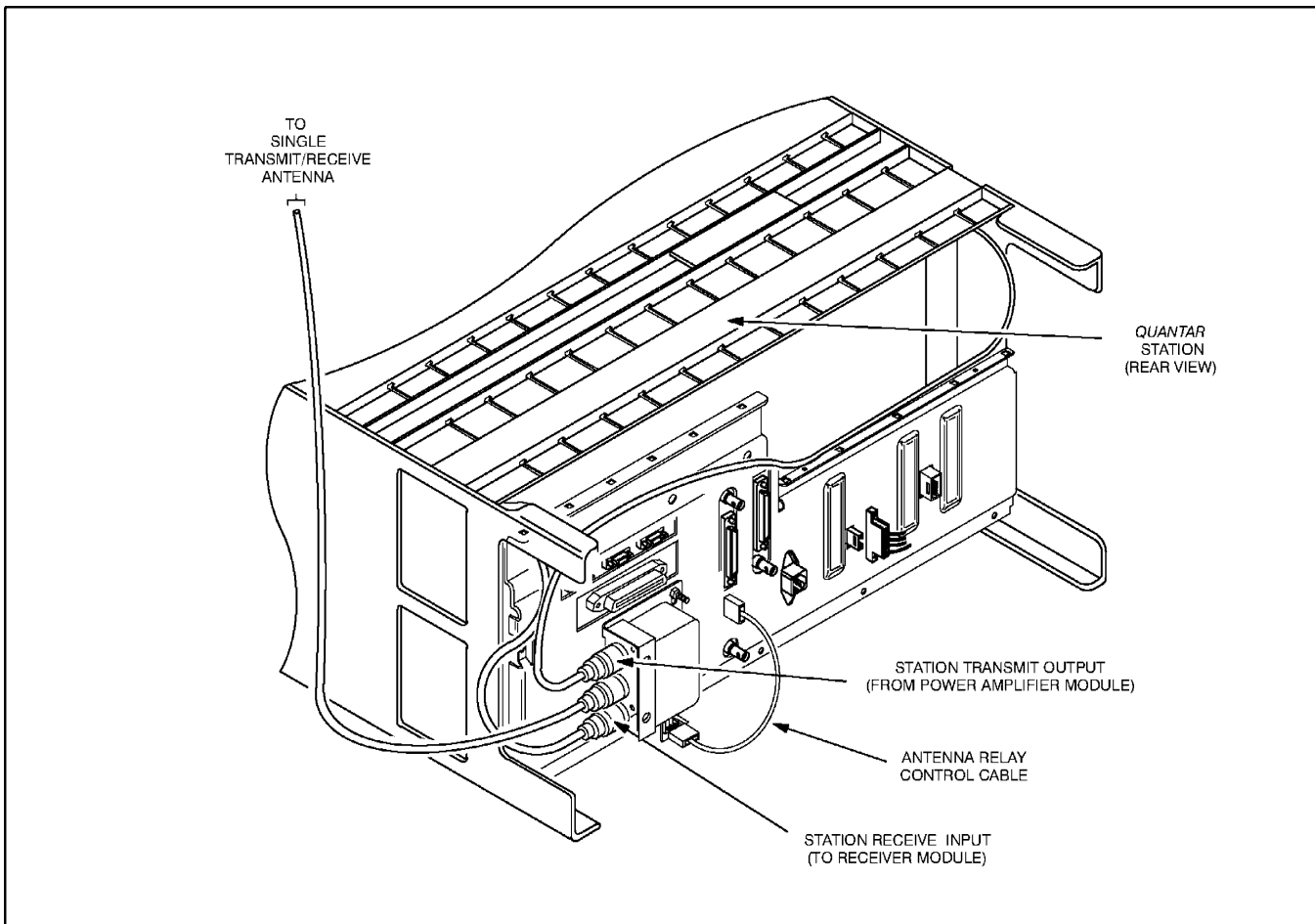
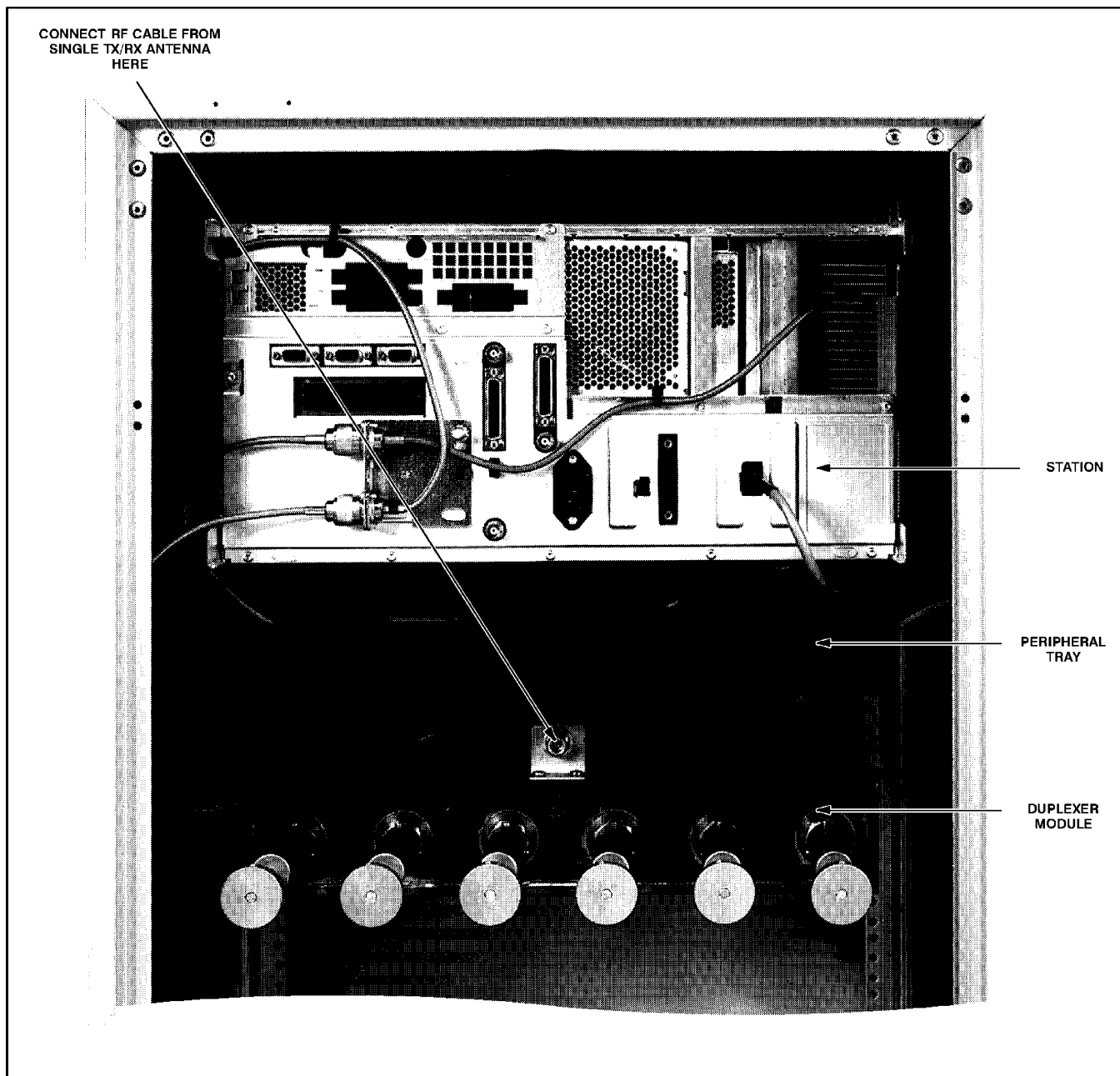

**Figure 17.** RF and Control Cable Connections for Station Equipped with Antenna Relay

## RF Cabling Connections (Continued)

### *Duplexer Option*

The Duplexer Option may be installed with or without the Triple Circulator Option. In either configuration, connect the rf cable to/from the single TX/RX antenna to the Duplexer Module as shown in Figure 18 (for VHF), Figure 19 (for UHF), or Figure 20 (for 800/900 MHz).



**Figure 18.** TX/RX Antenna Cable Connection to Duplexer Module (VHF; Triple Circulator Configuration Shown)

## RF Cabling Connections (Continued)

### Duplexer Option (continued)

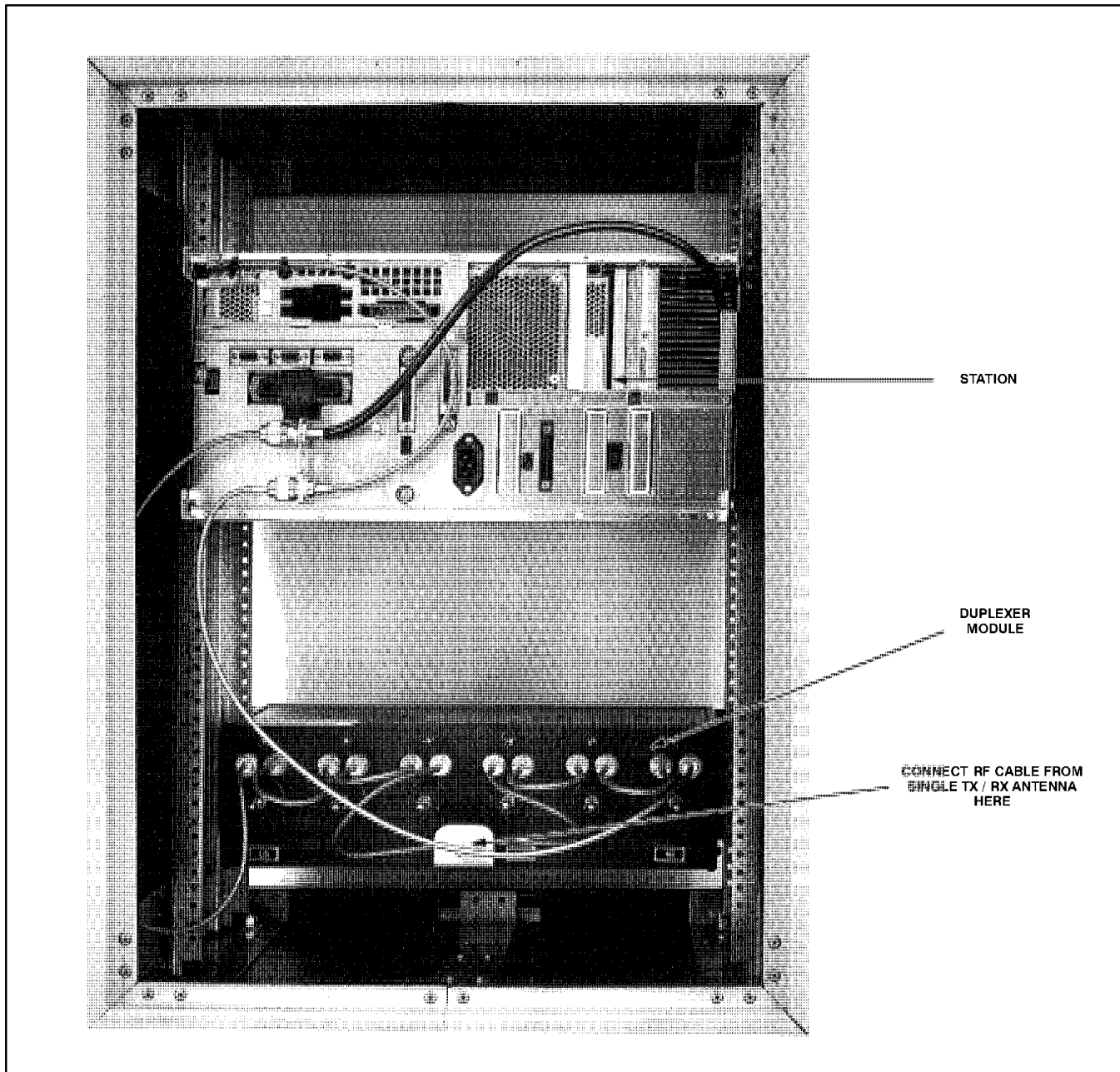

**Figure 19.** TX/RX Antenna Cable Connection to Duplexer Module (UHF)

**RF Cabling Connections  
(Continued)**

**Duplexer Option (continued)**

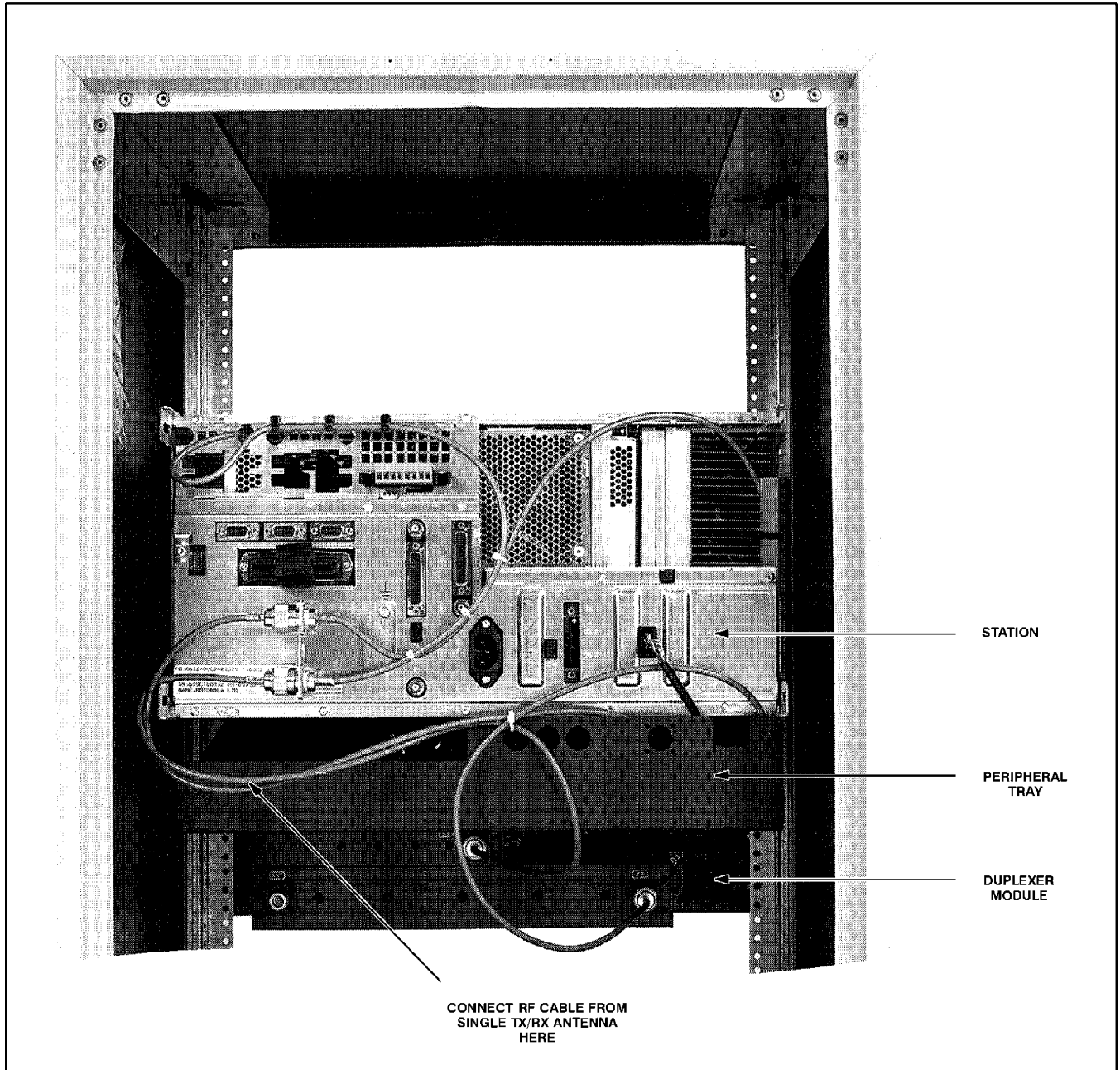

**Figure 20.** TX/RX Antenna Cable Connection to Duplexer Module (800/900 MHz; Triple Circulator Configuration Shown)

---

## Connecting System Cables

Note: **IntelliRepeater** networks may be either D-LAN or Ethernet. Refer to page 40 for instructions on connecting the stations in an Ethernet network.

Note: Options X148AA–X150AA provide an **IntelliRepeater** LAN cable kit which includes a PhoneNet interface box, an RJ-11 terminator, and a length (10', 25', or 50') of telephone cable with RJ-11 connectors on each end.

### Introduction

Depending on the type of communications system and options, various system cables must be connected to the station backplane. Make the connections as described in the following paragraphs.

### IntelliRepeater D-LAN Cabling Connections

A typical Motorola *IntelliRepeater* trunking site is comprised of multiple *IntelliRepeater*–capable stations connected together in a local area network. One of the stations is assigned to act as the current active master and is responsible for all call processing and channel assignments within the site. The other stations act as voice channel repeaters under control of the current active master.

Cabling for an *IntelliRepeater* trunking site using a D-LAN network consists of making the LAN connections between each of the stations. Make the cabling connections as follows.

- Step 1.** Select a station to be at one end of the network. Note that the station need not be the station selected to serve as the current active master.
- Step 2.** Connect the 9-pin D-type connector (part of the *PhoneNet* interface box) to connector DLAN1 (located on the station backplane, as shown in Figure 21).
- Step 3.** Install an RJ-11 terminator in one of the RJ-11 ports on the *PhoneNet* interface box. (The empty RJ-11 port at each end of the network must be terminated with an RJ-11 terminator.)
- Step 4.** Select the end of the telephone cable with a ground wire and spade terminal attached. Connect the RJ-11 connector into the empty port of the *PhoneNet* interface box; connect the spade lug to the station chassis screw, as shown in Figure 21.
- Step 5.** Install a *PhoneNet* interface box to the remaining stations in the *IntelliRepeater* network.
- Step 6.** Connect the stations together in a “daisy chain” fashion, as shown in Figure 21. Remember to connect the ground wire and spade terminal to the station chassis screw on each station.
- Step 7.** Install an RJ-11 terminator in the empty RJ-11 port in the *PhoneNet* interface box on the last station in the network.

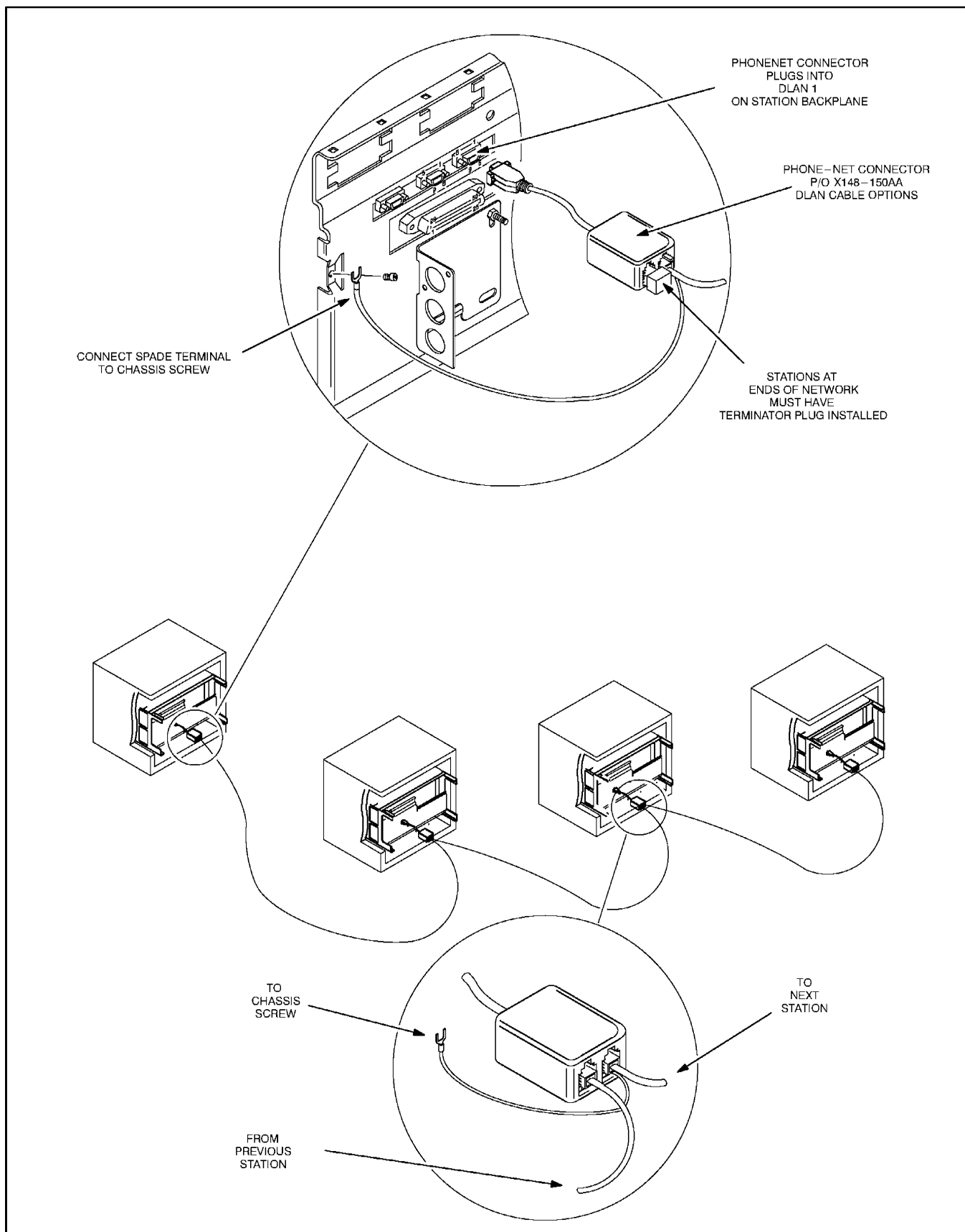

**Figure 21.** IntelliRepeater Trunking Site D-LAN Network Cabling Detail

## Connecting System Cables (Continued)

*Note:* **IntelliRepeater** networks may be either D-LAN or Ethernet. Refer to page 38 for instructions on connecting the stations in a D-LAN network.

*Note:* A coaxial cable and a T-connector is provided with each **IntelliRepeater** station shipped from the factory. A site termination kit (Option X843AB) provides two terminators, a T-connector to serve as the network access point, and a circular insulating pad.

### IntelliRepeater Ethernet Cabling Connections

Cabling for an *IntelliRepeater* trunking site using an Ethernet network consists of making the 10BASE-2 (coaxial) cabling connections between each of the stations. Make the cabling connections as follows.

- Step 1.** Connect a T-connector to BNC connector #22 on the backplane of each station in the network.
- Step 2.** Select two stations, one at each end of the network. One will be the terminated end of the Ethernet network, the other will be the access point of the Ethernet network.
- Step 3.** Place a terminator on one end of the T-connector on the station selected to be at the terminated end of the network, as shown in Figure 22.
- Step 4.** Using the supplied 10BASE-2 coaxial cables, connect the stations together in a "daisy chain" fashion, as shown in Figure 22.
- Step 5.** Create a network access point by connecting the last station to a T-connector and terminating the other end. This T-connector serves as the access point for the Ethernet network. This T-connector may be used to connect a PC to the network to download station software to the FLASH memory in each of the *IntelliRepeater* stations.
- Step 6.** Insulate each T-connector by folding the circular insulating pad around the connector and pressing it together until it sticks to itself, holding it in place.

**Important!** Ethernet networks utilize a floating ground. In order to eliminate possible data corruption resulting from multiple ground points in the network, the network should be grounded at **only one point**. This is typically accomplished at the terminated end of the network by using a terminator with an attached ground wire. Attach the ground wire to the station chassis. Make sure that the other T-connectors and cables in the network are not grounded to any station, either intentionally or accidentally, by using the circular insulating pads on every T-connector.

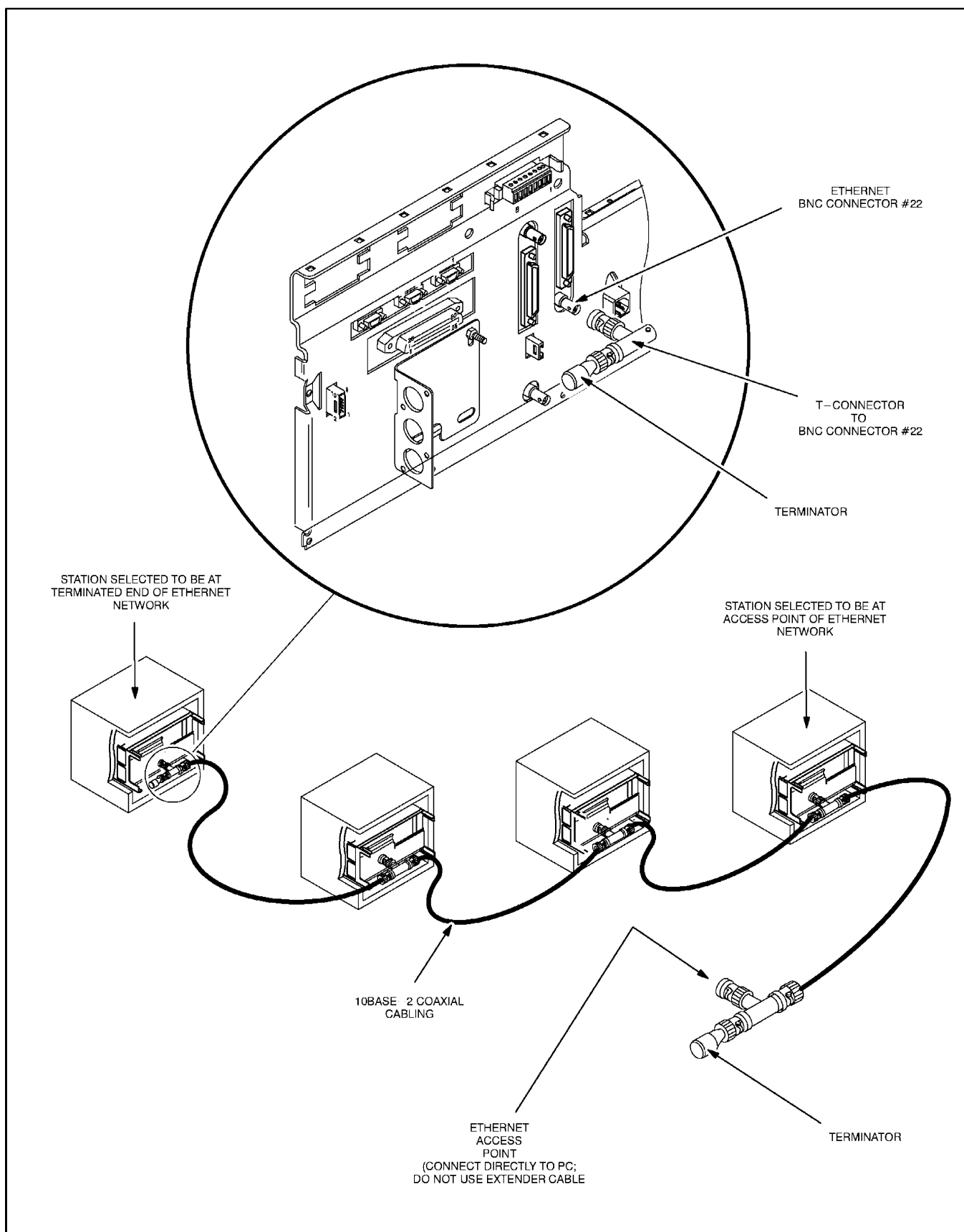

Figure 22. IntelliRepeater Trunking Site Ethernet Network Cabling Detail



## Connecting System Cables (Continued)

### 6809 Trunking Cabling Connections

Connect the control cable from the 6809 Trunking Controller to the station backplane as shown in Figure 23 below.

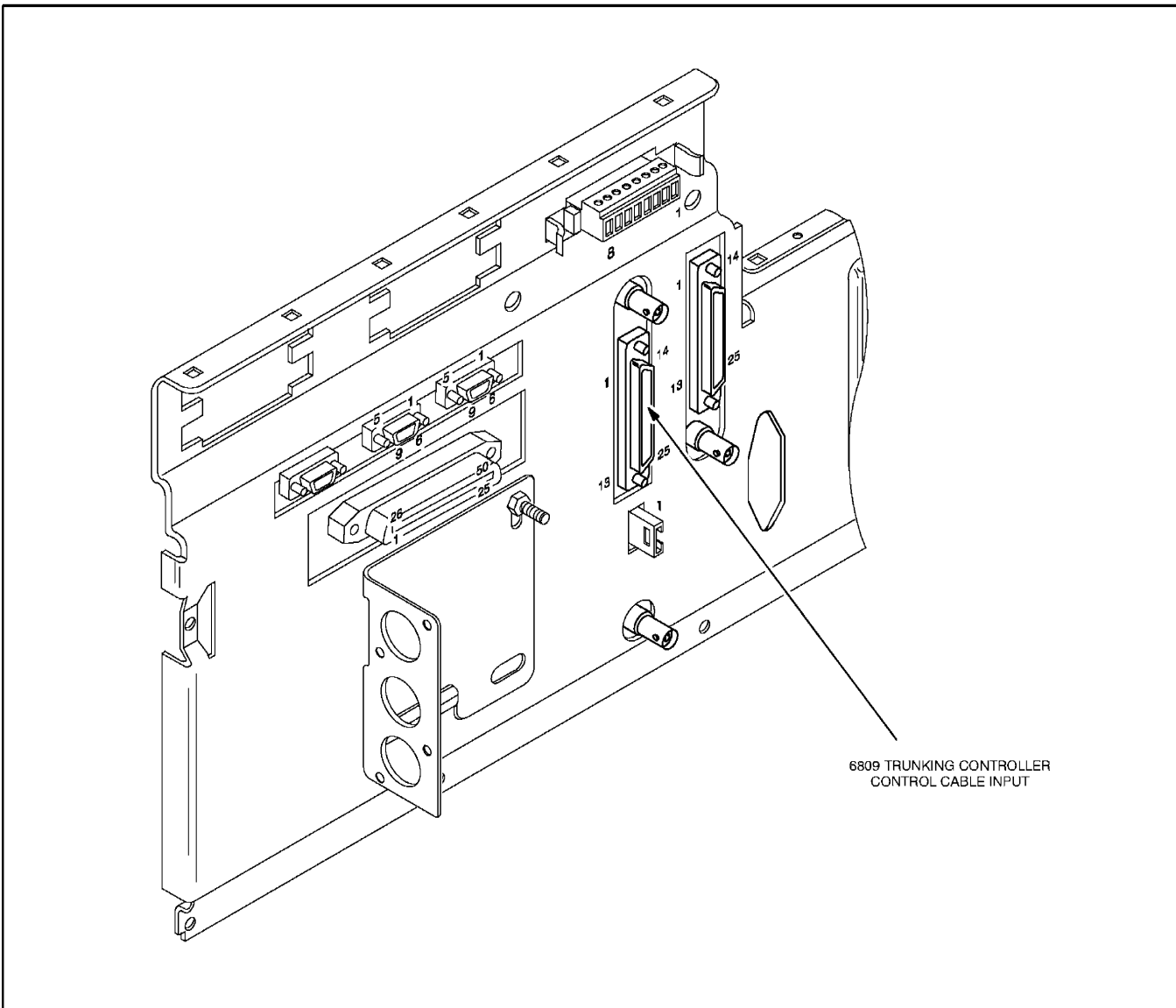
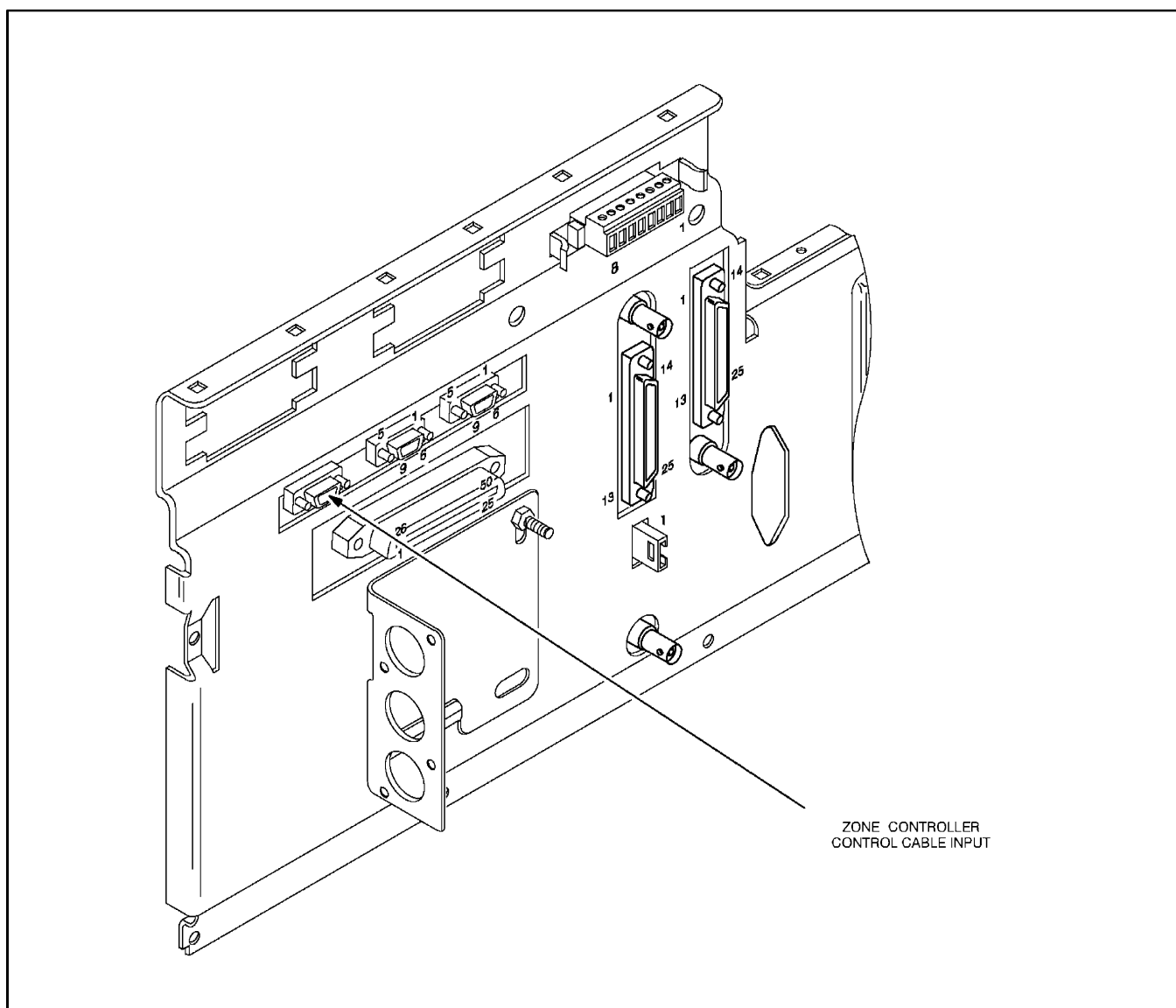

**Figure 23.** Connecting 6809 Trunking Controller Cable

## Connecting System Cables (Continued)

### Zone Controller Cabling Connections

Connect the control cable from the Zone Controller to the station backplane as shown in Figure 24 below.

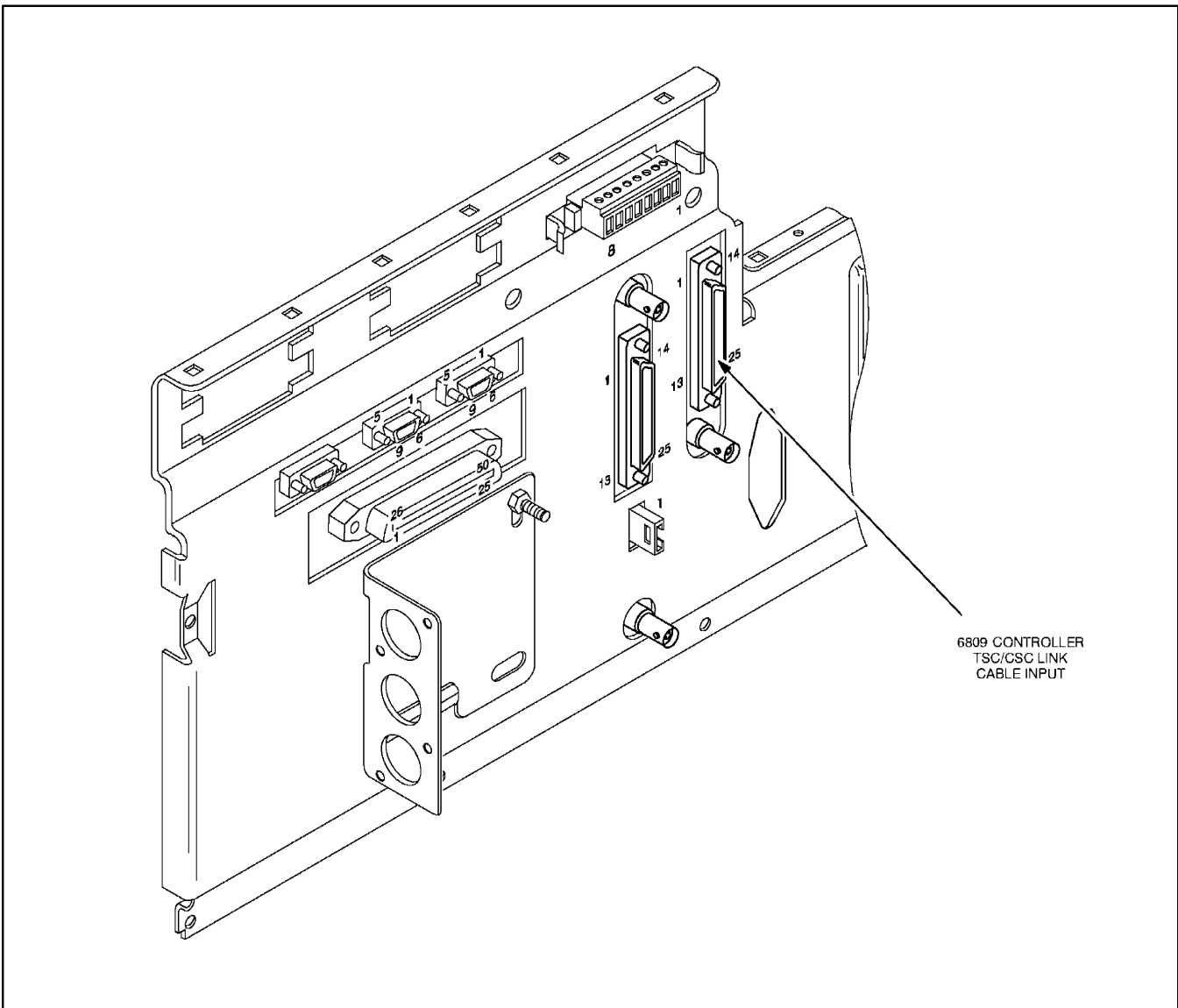

**Figure 24.** Connecting Zone Controller Cable

**Connecting System Cables  
(Continued)**

**6809 Controller TSC/CSC Link Cabling Connections**

Connect the TSC/CSC link cable (broadcast box) from the 6809 Controller to the station backplane as shown in Figure 25 below.



**Figure 25.** Connecting Zone Controller Cable

## Connecting Telephone Lines

### Introduction

In conventional systems where the station is controlled by a remote console, or in wide area systems utilizing comparators, phone lines must be connected between the station and the remote equipment. The phone lines may carry analog voice and/or *ASTRO*-encoded voice. Also carried on the phone lines is one of two types of remote control signaling (Tone Remote Control or *ASTRO* digital packets). The following information defines the specifications for the phone lines, the location on the station backplane for phone line connections, and which of the four (4) wireline circuits to use for various system types.

### Telephone Line Specifications

Most telephone companies recognize either “3002” or “Type 5” as designations to define phone line types and associated electrical specifications. Telephone lines meeting the specifications for either of these types are acceptable for use with the *Quantar* station. The following table shows the specifications for “3002” and “Type 5” phone line types.

**Type 5 and “3002” Phone Line Specifications**

Parameter	Type 5 Specification	3002 Specification
Loss Deviation	±4.0 dB	±4.0 dB
C–Notched Noise	51 dBrnCO	51 dBrnCO
Attenuation Distortion: 504 to 2504 Hz 404 to 2804 Hz 304 to 3004 Hz	–2.0 to +8.0 dB –2.0 to +10.0 dB –3.0 to +12.0 dB	–2.0 to +8.0 dB spec not available –3.0 to +12.0 dB
Signal to C–Notched Noise Ratio	≥ 24 dB	≥ 24 dB
Envelope Delay Distortion: 804 to 2604 Hz	1750 μsec	1750 μsec
Impulse Noise Threshold	71 dBrnCO	
Intermodulation Distortion: R2 R3	≥ 27 dB ≥ 32 dB	≥ 25 dB ≥ 30
Phase Jitter: 20–300 Hz 4–300 Hz	≥ 10 Degrees ≥ 15 Degrees	≥ 25 Degrees ≥ 30 Degrees
Frequency Shift	± 3 Hz	± 5 Hz

## Connecting Telephone Lines (Continued)

### Location of Telephone Line Connections

For added convenience, telephone line connections may be made in one of two locations on the station rear panel.

- 50-pin Telco Systems Connector
- Orange 8-Position Screw Terminal Connector

The location of the telephone line connections is shown in Figure 26. Note that these connections are **not** surge or transient protected. Refer to *Standards and Guidelines for Communication Sites (R56) 68P81089E50-A* for details.

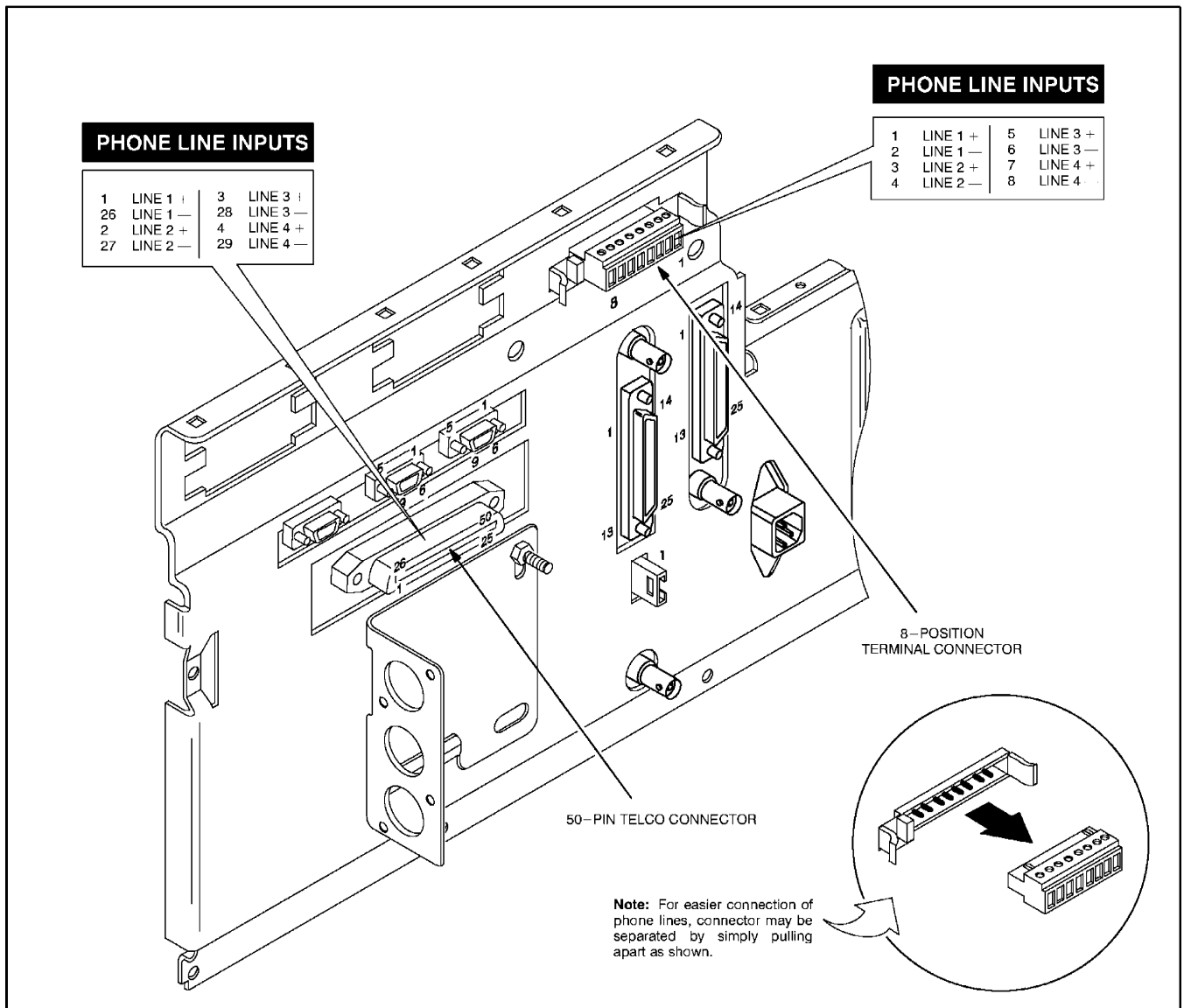

Figure 26. Two Locations for Telephone Line Connections

---

## Connecting Telephone Lines (Continued)

**Note:** Stations equipped with a 4-wire Wireline Interface Board (Model CLN6955) can support a single 4-wire or a single 2-wire telephone line connection. Stations equipped with an 8-wire Wireline Interface Board (Model CLN6956) can support two 4-wire or a single 2-wire telephone line connection. Refer to the Wireline Interface Board section in this manual for details.

### **2-Wire / 4-Wire Jumper Setting**

Wireline Interface Boards are shipped with the 2-wire/4-wire jumper (JU1010) installed in the 4-wire position. If required for your installation, move the jumper to the 2-wire position. Refer to the appropriate (per model) Wireline Interface Board section in this manual for jumper details.

### **Input/Output Impedance Matching Jumper Settings**

Wireline Interface Boards are shipped with the input/output impedance matching jumpers installed in the 600  $\Omega$  positions. If required for your installation, move the jumpers to the desired positions. Refer to the appropriate model Wireline Interface Board section in this manual for jumper details.

### **System Type vs Wireline Circuit Matrix**

The following table shows which of the four (4) wireline circuits to use for various system types.

## Connecting Telephone Lines (Continued)

### System Type vs Wireline Circuit Matrix Table

System Type	Line 1 (Note 1)	Line 2 (Note 1)	Line 3 (Note 3)	Line 4 (Note 3)
Conventional Local Area Analog	Console	Console	Not Used	Not Used
Conventional Local Area Analog with Repeater Access	Console	Console	Not Used	Not Used
Conventional Wide Area Analog	Comparator	Comparator	Not Used	Not Used
Conventional Simulcast Wide Area Analog	(Note 2)	Comparator	Not Used	Not Used
Conventional Local Area <i>ASTRO</i>	DIU	DIU	Not Used	Not Used
Conventional Local Area <i>ASTRO</i> w/Repeater Access	DIU	DIU	Not Used	Not Used
<i>IntelliRepeater</i> Trunking Wide Area Analog	<i>SMARTZONE</i> Audio Switch	<i>SMARTZONE</i> Audio Switch	Not Used	Not Used
6809 Trunking Single Site Analog	Interconnect	Interconnect	Not Used	Not Used
6809 Trunking Single Site Analog w/Console Priority Interface	Console	Console	Interconnect (8-Wire WIB Req'd)	Interconnect (8-Wire WIB Req'd)
6809 Trunking Wide Area Analog	Comparator	Comparator	Not Used	Not Used
6809 Trunking Simulcast Wide Area Analog	(Note 2)	Comparator	Not Used	Not Used

#### Notes:

- For 4-wire systems, Line 1 is transmit audio (landline to station), and Line 2 is receive audio (station to landline).  
For 2-wire systems, Line 2 is transmit and receive audio (conventional local area analog only).
- For Simulcast stations, transmit audio is connected from RDM (or equivalent) to GEN TX DATA+ and – on backplane.
- Lines 3 and 4 can be used with the Enhanced WildCard Option for customer-specific applications (in analog stations only).  
The optional 8-wire Wireline Interface Module is required.

## Connecting V.24 Board

**Note** Connecting to a local DIU or ASTRO-TAC Comparator requires a null modem cable and programming the station for Internal Clock Generation (refer to the RSS User's Guide for details).

For Quantar/Quantro Conventional stations (hybrid links) and SMARTZONE Trunking stations (V.24 required), connections to/from the station are made using a V.24 Interface Board (installed on the Wireline Interface Board). This board (Option X889AC) allows connections to be made between external V.24 modem equipment and the station via an RJ-45 connector accessible on the front panel (as shown below).

Make the connections and DIP Switch settings as shown in Figure 27.

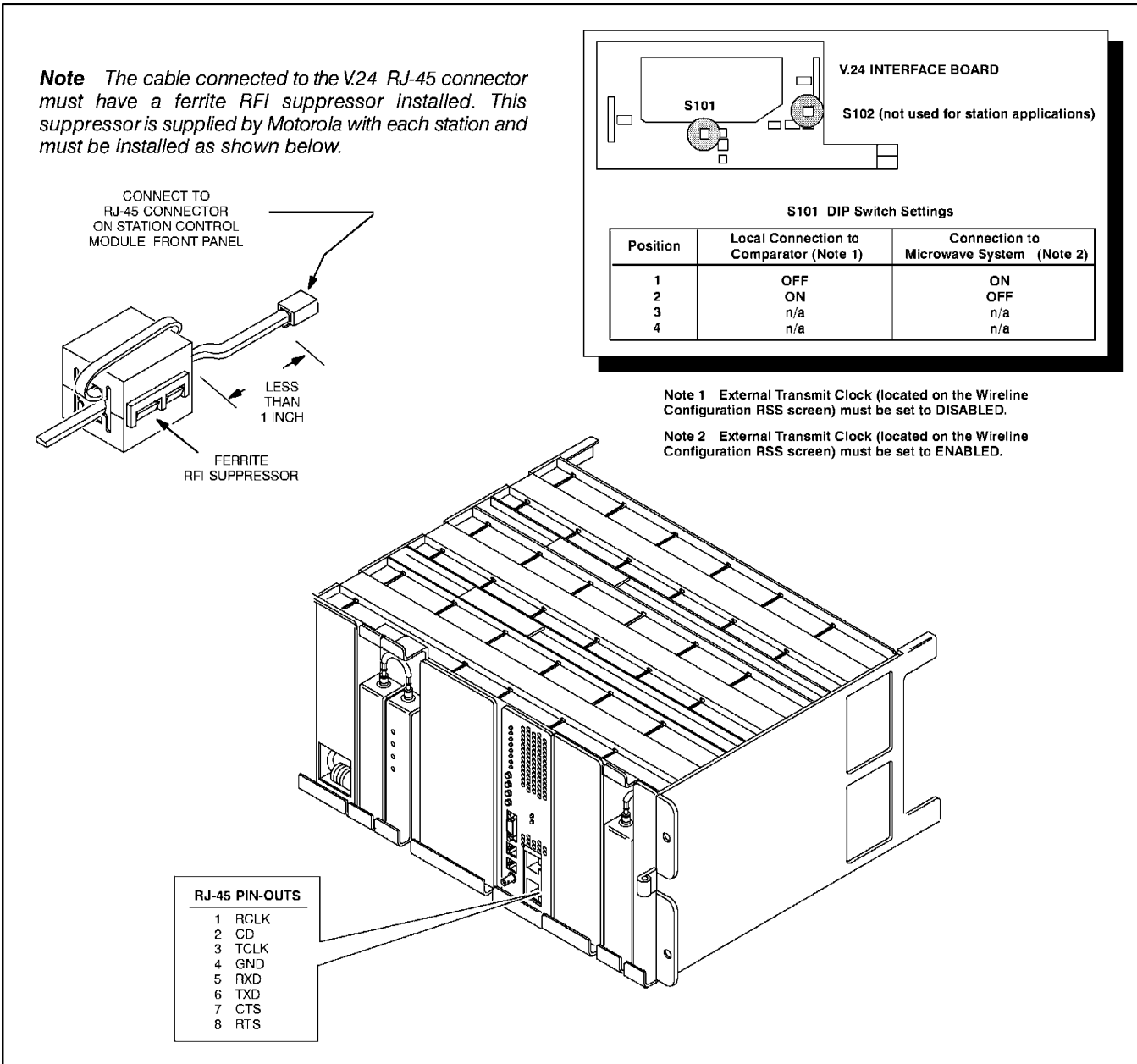
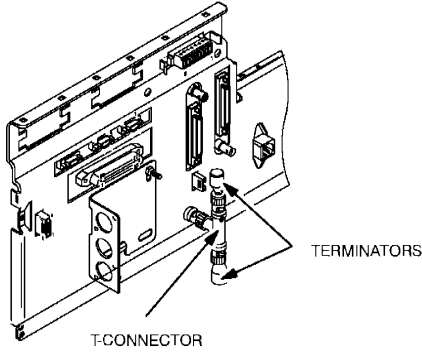

Figure 27. Making V.24 Board Connections



## Connecting External Reference

**Note** For standalone stations equipped with an internal UHSO module, make sure the BNC connector #30 (located on the backplane) is terminated as shown below.



### Overview

In some cases ( e.g., Simulcast, 900 MHz, etc.), the use of a frequency reference other than the internal reference oscillator (located on the Station Control Board) is required. In these cases, either an internal Ultra High Stability Oscillator (UHSO, available as an option) or an external 5 MHz or 10 MHz source (typically from a rubidium-based standard) must be employed. Without one of these sources connected, the station synthesizers will not maintain the required stability.

### Single Station Connections

For stations without the internal UHSO option, connect the output of an external 5 MHz or 10 MHz reference source to one of two station connectors, as shown in Figure 28. (The external source must remain connected and powered at all times during station operation; otherwise, the synthesizers will fail to lock and the station will not transmit or receive.)

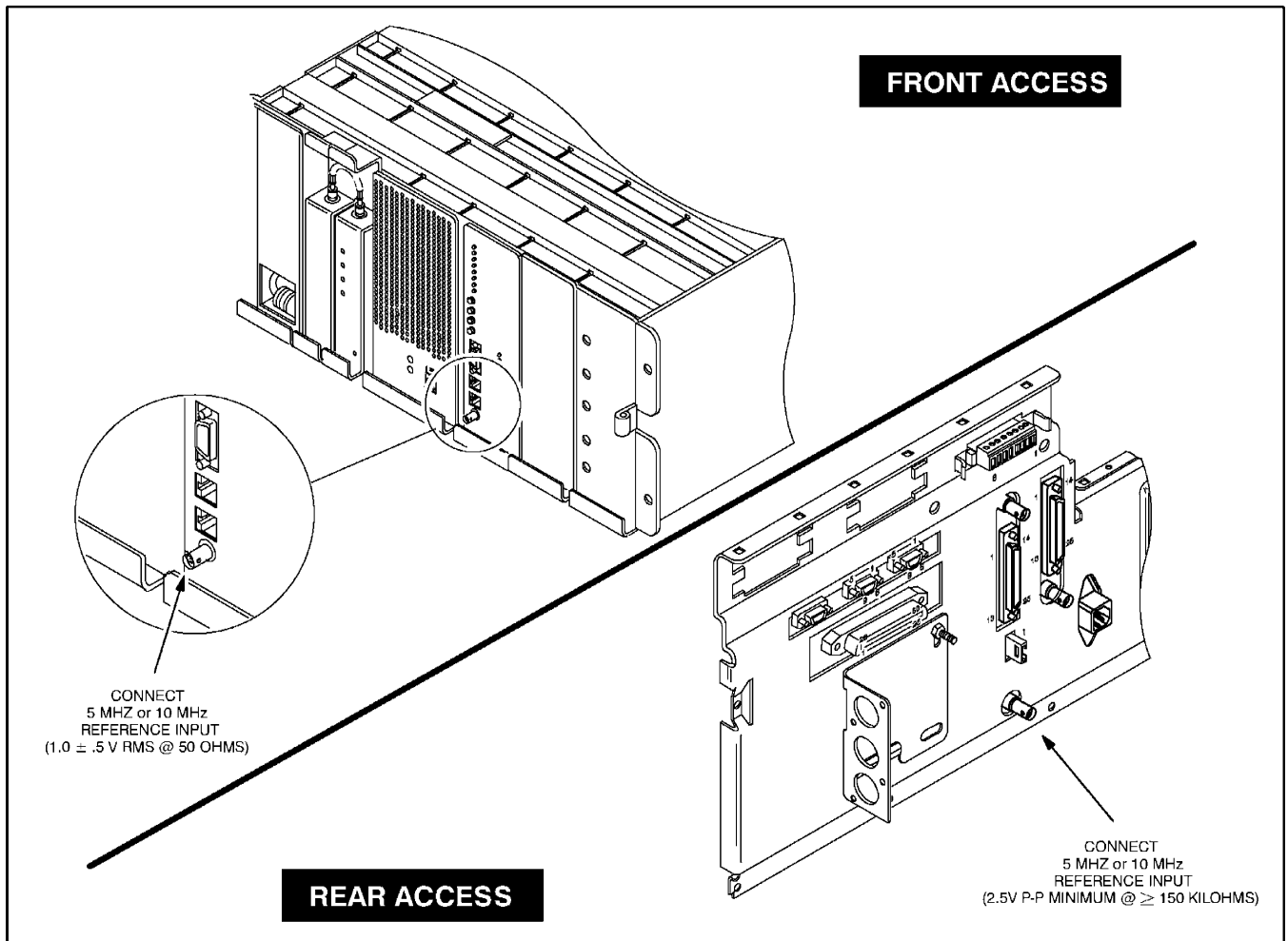

**Figure 28.** Connecting External 5 MHz or 10 MHz Reference Source to Single Station

---

## Connecting External Reference (continued)

### **Multi-Drop Connections**

For sites with multiple stations that require a high-stability reference signal, a multi-drop configuration may be used. In this configuration, a single source (either an external signal source or a station equipped with a UHSO module) provides the reference signal to all stations at the site. Make the connections as shown in Figure 29.

Note the following guidelines and requirements:

- A maximum of six (6) *Quantar* stations (mounted in same rack) can be connected in a multi-drop configuration.
- An Ultra High Stability Oscillator module (UHSO) must be installed in the bottom station only.
- RSS programming for bottom station must be set for **INTERNAL — HIGH STABILITY** (*Freq Ref*: field on the *Hardware Configuration* screen). All other stations must be set for **EXTERNAL — 5 MHz**. Refer to the *Radio Service Software User's Guide 68P81085E35* for details on RSS programming.

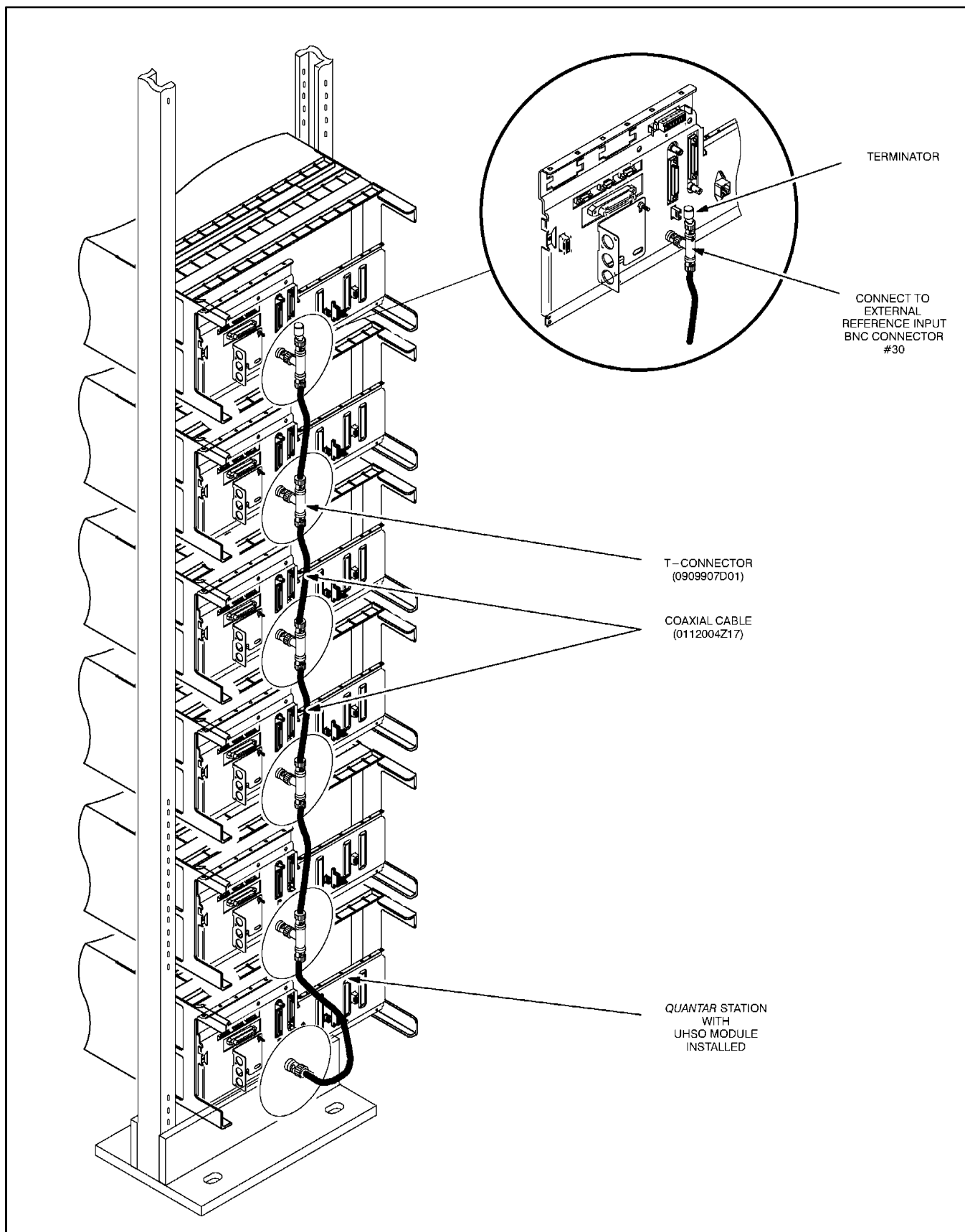

**Figure 29.** Multi-Drop Connections of Reference Source to Multiple Stations

## 4 POST-INSTALLATION CHECKOUT

After the station equipment has been mechanically installed and all electrical connections have been made, you may now apply power and check for proper operation prior to optimizing the station.

### Applying Power

Before applying power to the station, make sure all modules and boards are securely seated in the appropriate connectors on the backplane and that all rf cables are securely connected.

- Step 1.** Turn ON the circuit breaker controlling the ac outlet that is supplying power to the station Power Supply Module.
- Step 2.** Turn the station power ON using the rocker switch located on the Power Supply Module front panel.

### Verifying Proper Operation

#### *Introduction*

Upon turning the station power ON, a start-up sequence begins which performs certain tests and initialization before entering normal station operation. The station LEDs provide a visual indication of the progress of the start-up sequence, and may be decoded to determine which test (if any) has failed.

The following describes the behavior of the LEDs upon powering up the station, as well as how to decode the LEDs to isolate potential hardware and software malfunctions.

#### **Station Control Module LEDs Power Up Sequence**

- Step 1.** The **Station Fail** LED momentarily lights, followed by all eight LEDs turning on.
- Step 2.** The start-up sequence tests now run, and the LEDs go out (top to bottom) as each test is completed.
- Step 3.** After **Aux LED** is turned off, the **Station Fail** LED is turned on and (for Conventional/6809 stations only) the **Intercom** LED flashes while the station software and hardware are initialized.
- Step 4.** Once initialized, the **Station Fail** and **Intercom** LEDs are turned off and the **Station On** LED (green) is turned on. This indicates that the module has passed all the start-up tests and is now operational.

*continued on next page*

## Verifying Proper Operation (Continued)

### Station Control Module Failures

- If the **Station Fail** lights and stays on (Step 1), check to see if the Station Control Module and Power Supply Module are seated properly in the backplane. Also check to make sure that the EPROMs (two 40-pin socket-mounted ICs located on Station Control Board) are seated properly and installed with pin 1 of each IC closest to the center of the board. Otherwise, replace Station Control Module.
- If LEDs #6 and #7 (**Rx 2 Active** and **Rx Fail**, respectively) alternately blink, one of the start-up tests has failed, as indicated by one of the first three LEDs being turned on.
  - If LED #1 is turned on, reseal the FLASH SIMM in its socket; otherwise, replace the FLASH SIMM.
  - If LED #2 or #3 is turned on, check to make sure DRAM SIMMs are correct size for system application (*IntelliRepeater* stations require one 8 Mbyte DRAM SIMM). If correct size, reseal the DRAM SIMMs in sockets. Otherwise, replace DRAM SIMMs.
- If start-up tests are run successfully (all LEDs light and go off one by one) and the **Station Fail** lights and stays on (Step 3), replace Station Control Module.
- If start-up tests are run successfully (all LEDs light and go out one by one) and the **Station Fail** lights momentarily followed by all LEDs blinking, perform a software download to FLASH memory as described in the *Quantar/Quantro* RSS User's Guide (68P81085E35).

### Exciter Module LEDs Power Up Sequence

- Step 1.** After Station Control Module passes all start-up tests and becomes operational, all four Exciter LEDs momentarily light.
- Step 2.** The start-up sequence tests now run, and the LEDs go out (top to bottom) as each test is completed.
- Step 3.** Once **PA FAIL** is turned off, the **TX Lock** LED is turned on. This indicates that the module has passed all of the start-up tests and is now operational.

### Exciter Module Failures

- If LEDs #1 and #2 (**TX Lock** and **PA Full**, respectively) alternately blink, one of the start-up tests has failed. Check to make sure that the EPROM (40-pin socket-mounted IC located on Exciter Board) is seated properly and installed with pin 1 of the IC closest to the center of the board. Otherwise, replace Exciter Module.

*continued on next page*

---

## Verifying Proper Operation (Continued)

### **Wireline Module LEDs Power Up Sequence**

- Step 1.** After Station Control Module passes all start-up tests and becomes operational, the Wireline start-up tests now run.
- Step 2.** If all tests are passed, the **WL On** LED is turned on (green).

### **Wireline Module Failures**

- If the two LEDs alternately flash slowly (in any one of several possible flashing patterns), replace the Wireline Interface Board.

---

## Proceeding to Optimization

If all LEDs sequence properly, the station may be considered electrically functional and is ready for optimizing and alignment. Proceed to the *Optimization* section in this manual.

## 1 DESCRIPTION

After the station and ancillary equipment have been mechanically installed, properly cabled, and power applied (as described in the *Installation* section of this manual), the equipment must then be optimized before placing into operation.

An overview of the optimization tasks is as follows:

- Customize the station codeplug and saving the data to the station
- Perform the following alignment tasks:
  - Rx Wireline
  - Tx Wireline
  - Receiver RSSI calibration
  - Receiver Squelch Adjust
  - Battery Equalization
  - Reference Oscillator
  - Simulcast/ASTRO Launch Time Offset (required for *ASTRO* Simulcast systems only)
  
- Perform post-optimization checkout procedures, such as verifying power output, deviation, etc.

For detailed instructions to perform these optimization tasks, follow the procedures provided in *Optimizing a New Installation*, located in the RSS User's Guide (68P81085E35).

## 1 DESCRIPTION

This section describes the switches, pushbuttons, connectors and LED indicators provided on the *Quantar* station used during local operation of the station and servicing.

### Summary of Switches, Pushbuttons, and Connectors

The following switches, pushbuttons, and connectors are provided to allow the station to be operated and/or serviced locally. The location and function of these controls and connectors is shown in Figure 1.

#### Switches, Pushbuttons, and Connectors

Station Control Module	Power Supply Module
Volume Up Pushbutton Volume Down Pushbutton CSQ/PL/OFF Pushbutton (squench mode) Intercom Pushbutton Handset/Microphone Connector External Speaker Connector RSS Port Connector External 5 MHz Input BNC Connector	Main Power On/Off Switch

### Summary of LED Indicators

**Note:** Refer to the *Troubleshooting* section of this manual for detailed descriptions and interpretation of the LED indicators.

The following LED indicators are provided to indicate operating status of the station. The location of these controls and connectors is shown in Figure 1.

#### Summary of LED Indicators

Station Control Module	Power Supply Module	Exciter Module	Wireline Interface Module
Station On Station Fail Intcm/Acc D Control Ch Rx 1 Active Rx 2 Active Rx Fail V.24/Modem	Module Fail Power On	TX Lock PA Full PA Low PA Fail	WL On* WL Fail*  <i>*LEDs visible on Station Control Module front panel</i>

(Page 2 is blank)



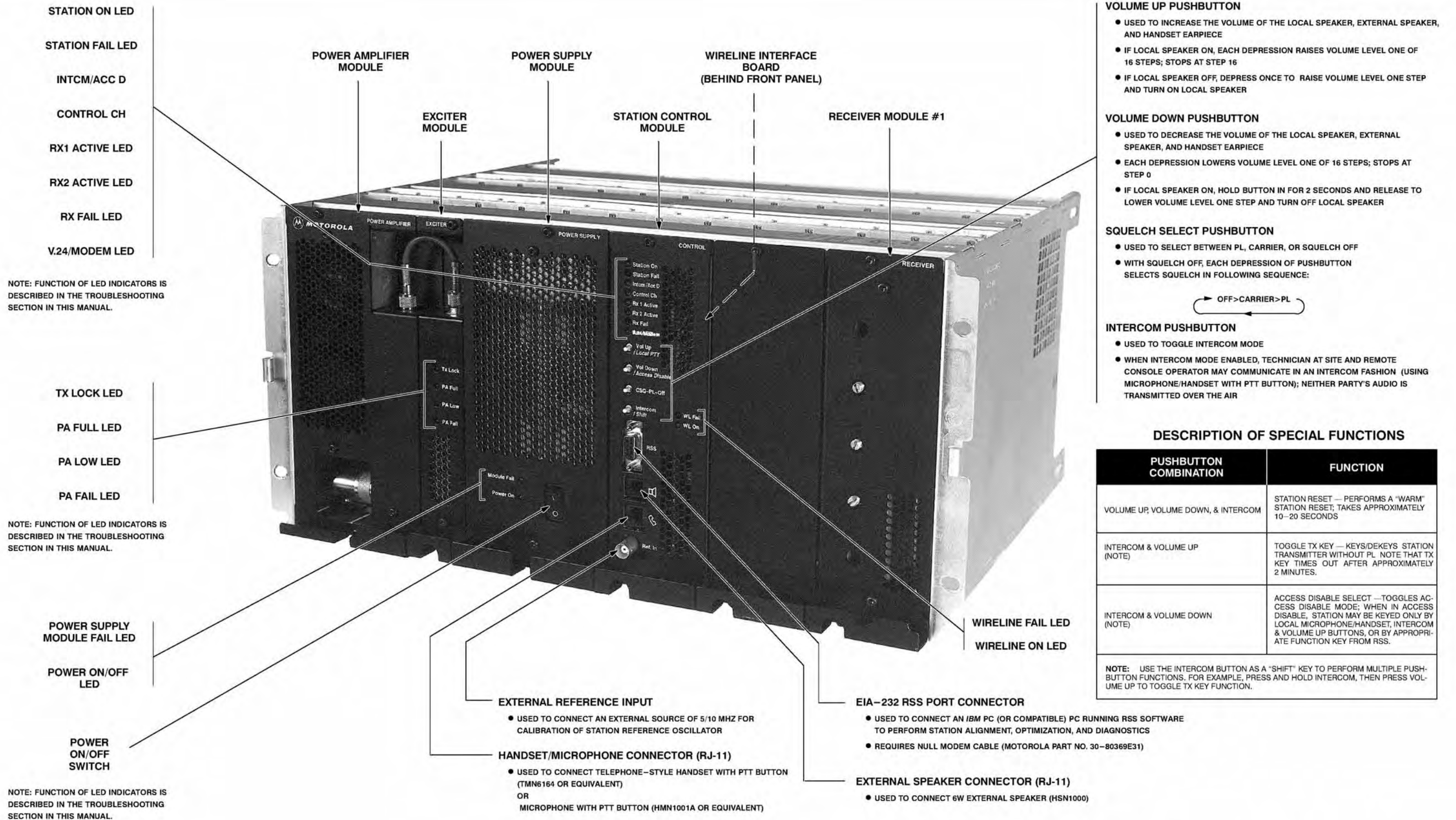

Figure 1. Switches, Pushbuttons, Connectors, and LED Indicators for Quantar Station (UHF Shown)

**VOLUME UP PUSHBUTTON**

- USED TO INCREASE THE VOLUME OF THE LOCAL SPEAKER, EXTERNAL SPEAKER, AND HANDSET EARPIECE
- IF LOCAL SPEAKER ON, EACH DEPRESSION RAISES VOLUME LEVEL ONE OF 16 STEPS; STOPS AT STEP 16
- IF LOCAL SPEAKER OFF, DEPRESS ONCE TO RAISE VOLUME LEVEL ONE STEP AND TURN ON LOCAL SPEAKER

**VOLUME DOWN PUSHBUTTON**

- USED TO DECREASE THE VOLUME OF THE LOCAL SPEAKER, EXTERNAL SPEAKER, AND HANDSET EARPIECE
- EACH DEPRESSION LOWERS VOLUME LEVEL ONE OF 16 STEPS; STOPS AT STEP 0
- IF LOCAL SPEAKER ON, HOLD BUTTON IN FOR 2 SECONDS AND RELEASE TO LOWER VOLUME LEVEL ONE STEP AND TURN OFF LOCAL SPEAKER

**SQUELCH SELECT PUSHBUTTON**

- USED TO SELECT BETWEEN PL, CARRIER, OR SQUELCH OFF
- WITH SQUELCH OFF, EACH DEPRESSION OF PUSHBUTTON SELECTS SQUELCH IN FOLLOWING SEQUENCE:

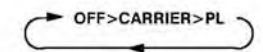

**INTERCOM PUSHBUTTON**

- USED TO TOGGLE INTERCOM MODE
- WHEN INTERCOM MODE ENABLED, TECHNICIAN AT SITE AND REMOTE CONSOLE OPERATOR MAY COMMUNICATE IN AN INTERCOM FASHION (USING MICROPHONE/HANDSET WITH PTT BUTTON); NEITHER PARTY'S AUDIO IS TRANSMITTED OVER THE AIR

**DESCRIPTION OF SPECIAL FUNCTIONS**

PUSHBUTTON COMBINATION	FUNCTION
VOLUME UP, VOLUME DOWN, & INTERCOM	STATION RESET — PERFORMS A "WARM" STATION RESET; TAKES APPROXIMATELY 10-20 SECONDS
INTERCOM & VOLUME UP (NOTE)	TOGGLE TX KEY — KEYS/DEKEYS STATION TRANSMITTER WITHOUT PL. NOTE THAT TX KEY TIMES OUT AFTER APPROXIMATELY 2 MINUTES.
INTERCOM & VOLUME DOWN (NOTE)	ACCESS DISABLE SELECT — TOGGLES ACCESS DISABLE MODE; WHEN IN ACCESS DISABLE, STATION MAY BE KEYED ONLY BY LOCAL MICROPHONE/HANDSET, INTERCOM & VOLUME UP BUTTONS, OR BY APPROPRIATE FUNCTION KEY FROM RSS.

**NOTE:** USE THE INTERCOM BUTTON AS A "SHIFT" KEY TO PERFORM MULTIPLE PUSHBUTTON FUNCTIONS. FOR EXAMPLE, PRESS AND HOLD INTERCOM, THEN PRESS VOLUME UP TO TOGGLE TX KEY FUNCTION.

NOTE: FUNCTION OF LED INDICATORS IS DESCRIBED IN THE TROUBLESHOOTING SECTION IN THIS MANUAL.

NOTE: FUNCTION OF LED INDICATORS IS DESCRIBED IN THE TROUBLESHOOTING SECTION IN THIS MANUAL.

NOTE: FUNCTION OF LED INDICATORS IS DESCRIBED IN THE TROUBLESHOOTING SECTION IN THIS MANUAL.

## 1 INTRODUCTION

This section provides routine maintenance recommendations for the *Quantar* and *Quantro* station and associated ancillary equipment.

### **Routine Maintenance Overview**

The *Quantar* and *Quantro* station and ancillary equipment have been designed with state-of-the-art technology and operate under software control, thus requiring minimal routine maintenance. Virtually all station operating parameters are monitored and self-corrected by the Station Control Module, making virtually all periodic adjustments and tuning unnecessary.

Providing that the equipment is installed in an area which meets the specified environmental requirements (see Pre-Installation planning for environmental specifications), the only routine maintenance task required is the calibration of the station reference oscillator circuit (and the optional UHSO, if installed). The calibration procedure is provided in the RSS User's Guide (68P81085E35).

**Note:** If the station equipment is installed in a particularly dusty environment, precautions must be taken to filter the air used for forced cooling of the station. Excessive dust drawn across and into the station circuit modules by the cooling fans can adversely affect heat dissipation and circuit operation. In such installations, be sure to clean or replace external filtering devices periodically. Refer to Pre-Installation Planning in the Installation section of this manual for recommended filtering techniques.

## 2 RECOMMENDED SCHEDULE

The circuit device(s) responsible for determining the station reference frequency exhibit slight variations in their operating characteristics over time ( “infant aging” ). Approximately 90% of the component aging process occurs during the first year of operation. After the initial one year period, the device(s) remain stable for a substantially longer period of time. Therefore, it is recommended that the station reference oscillator be calibrated after one year of operation, and thereafter less often as prescribed in a recommended schedule of periodic calibration.

### Station Reference Calibration Schedule

After performing the initial one year calibration procedure, periodic calibration is required according to the schedule shown below. Note that the intervals are affected by the accuracy (in PPM) required either for FCC compliance or by the system requirements, whichever is more stringent.

<b>Table 1. Recommended Intervals for Calibrating Station Reference Oscillator (After Initial One–Year Calibration)</b>	
<b>Accuracy Desired/Required</b>	<b>Recommended Interval</b>
±5 PPM	Every 4 years
±2.5 PPM	Every 2 years
±1.5 PPM	Once yearly
±1.0 PPM (821–824 MHz Public Safety Band)	Once yearly
±0.1 PPM (see note)	Once yearly
<p><b>Note:</b> ±0.1 PPM accuracy requires the use of either the UHSO Option X873AA or an external 5 MHz source. The UHSO option requires both the internal station reference oscillator <b>and</b> the UHSO to be calibrated once yearly using the RSS. When using an external 5 MHz source, the internal station reference oscillator must be calibrated once yearly using the RSS, and the external source must be calibrated once yearly using the manufacturer’s recommended procedure.</p>	

## 1 INTRODUCTION

This section provides troubleshooting recommendations and procedures for the *Quantar* station and associated ancillary equipment.

### Troubleshooting Overview

The troubleshooting procedures and supporting diagrams provided in this section allow the service technician to isolate station faults to the module/assembly level. Defective modules are then replaced with known good modules to restore the station to proper operation.

Troubleshooting information includes:

- Table defining the function of the various alarm LED indicators
- Troubleshooting flow charts
- Module replacement procedures
- Post-repair procedures for performing alignment following replacement of defective modules

## 2 RECOMMENDED TEST EQUIPMENT

The following list of test equipment is recommended to perform troubleshooting procedures on the *Quantar* station and ancillary equipment.

### List of Test Equipment

- Motorola R2001 or R2600 Series Communications Analyzer (or equivalent)
- PC with RSS program
- 9-pin female to 9-pin male Null Modem Cable (30-80399E31)
- In-Line Wattmeter (Motorola S-1350 or equivalent)
- Dummy Load (50Ω, station wattage or higher)
- Handset/Microphone with PTT switch (TMN6164 or equivalent)
- Torx driver with #15 bit (for removal of module front panels)
- IC Extraction Tool (01-80386A04)

## 3 TROUBLESHOOTING PROCEDURES

The troubleshooting and repair philosophy for the *Quantar* station and ancillary equipment is one of Field Replaceable Unit (FRU) substitution. The station is comprised of self-contained modules (FRUs) which, when determined to be faulty, may be replaced with a known good module to quickly bring the station back to normal operation. The faulty module must then be shipped to a Motorola repair depot for further troubleshooting and repair to the component level.

Because the *Quantar* station is computer-controlled and employs state-of-the-art digital signal processing techniques, many of the troubleshooting procedures require the use of the Motorola-supplied Radio Service Software (RSS). The RSS is run on a PC (or compatible) with RS-232 communication port capability. The RSS allows the technician to access alarm log files, run diagnostics, and set up the equipment for various audio and rf tests. Complete details on the operation of the RSS are provided in the RSS User's Guide (68P81085E35).

### Troubleshooting Overview

#### **Introduction**

Two procedures are provided for troubleshooting the *Quantar* station and ancillary equipment. Each procedure is designed to quickly identify faulty modules, which may then be replaced with known good modules to restore proper station operation.

#### **Procedure 1 — Routine Site Visit Functional Checkout**

Procedure 1 consists of a series of non-intrusive tests that can be quickly run during a routine site visit. This procedure allows the technician to verify the proper station operation without taking the station out of service. An overview of the procedure is shown in the flow chart (Figure 1) on page 3.

#### **Procedure 2 — Troubleshooting A Reported/Suspected Problem**

Procedure 2 should be used when an equipment problem has been either reported or is suspected. This procedure is comprised of both non-intrusive (equipment not taken out of service) and intrusive (requiring the equipment be temporarily taken out of service) tests that allow the technician to troubleshoot reported or suspected equipment malfunctions. An overview of the procedure is shown in the flow chart (Figure 2) on page 4.

#### **How to Use These Troubleshooting Procedures**

Perform the following basic steps in order to efficiently troubleshoot the *Quantar* station equipment.

- Step 3.** Select the appropriate troubleshooting procedure flow chart (Procedure 1 or Procedure 2).
- Step 4.** Perform the tasks given in the selected flow chart. Tasks requiring additional explanation are marked with page references. Locate the additional information, perform the tasks (if any), and return to the flow chart.
- Step 5.** Once the faulty module has been identified, proceed to *Module Replacement Procedures*, beginning on page 21.

**PROCEDURE 1**

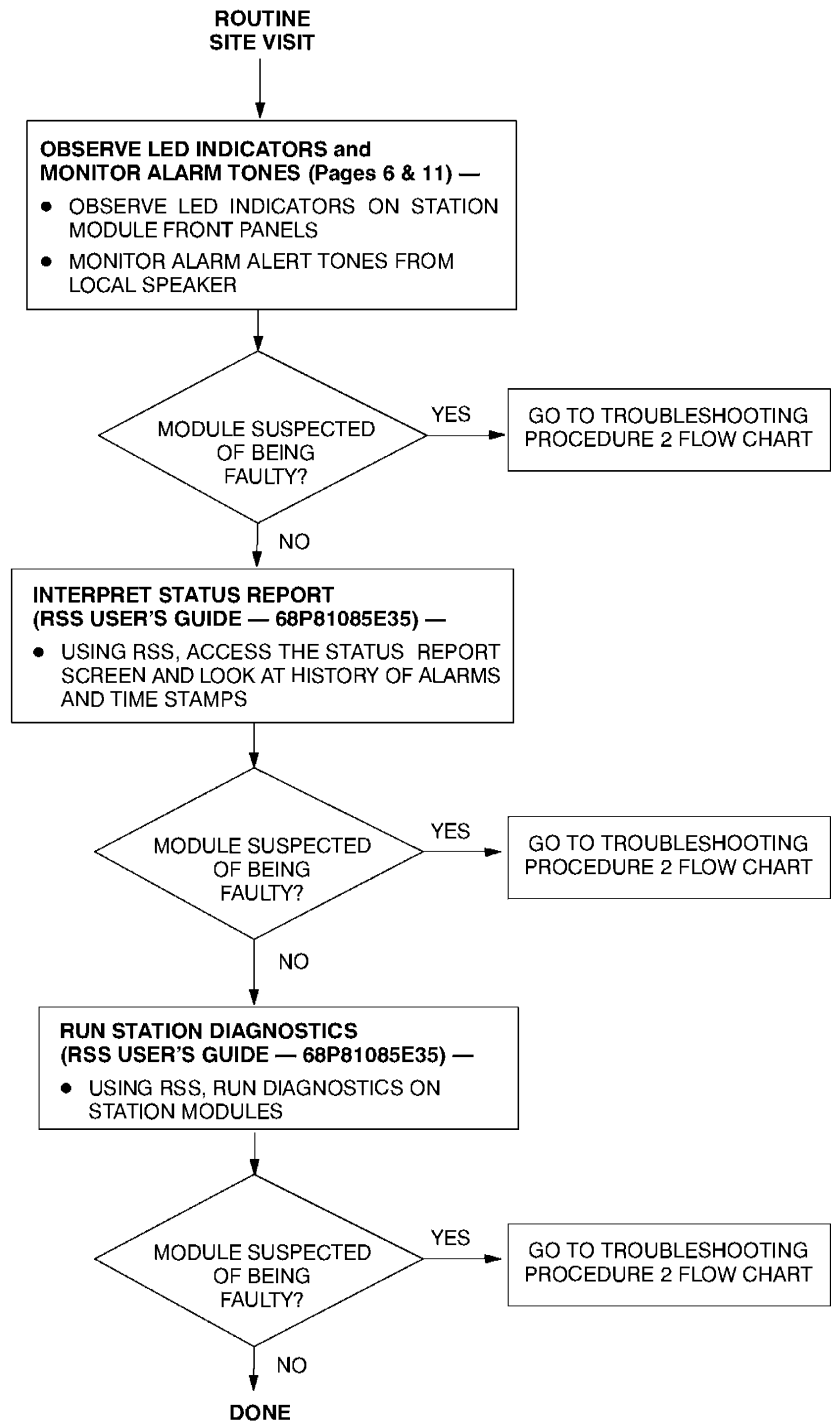

**Figure 1.** Quantar Station Troubleshooting Overview (Procedure 1 — Routine Site Visit)

**▶ PROCEDURE 2**

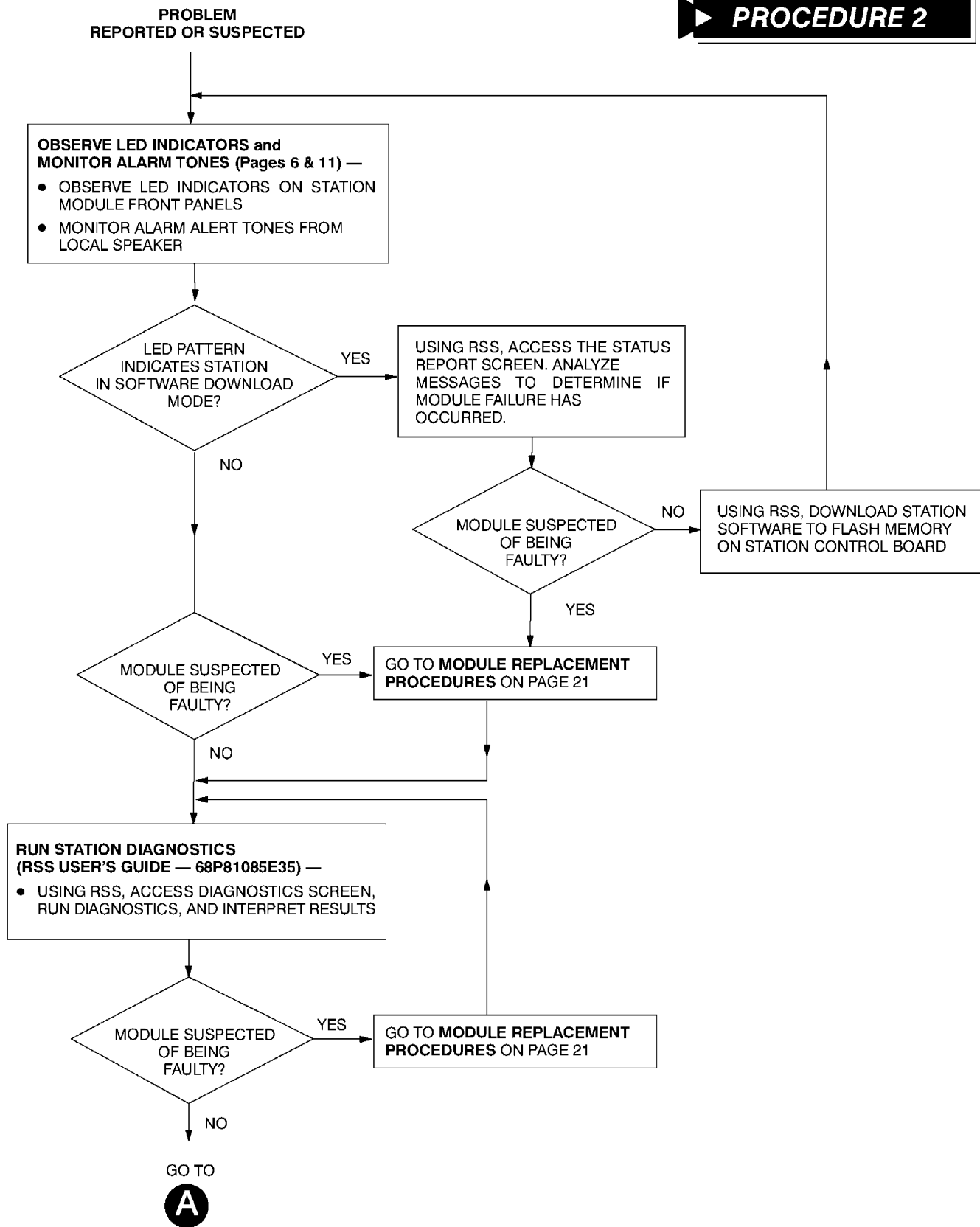

**Figure 2.** Quantar Station Troubleshooting Overview (Procedure 2 — Reported or Suspected Problem)

**▶ PROCEDURE 2 (Cont'd)**

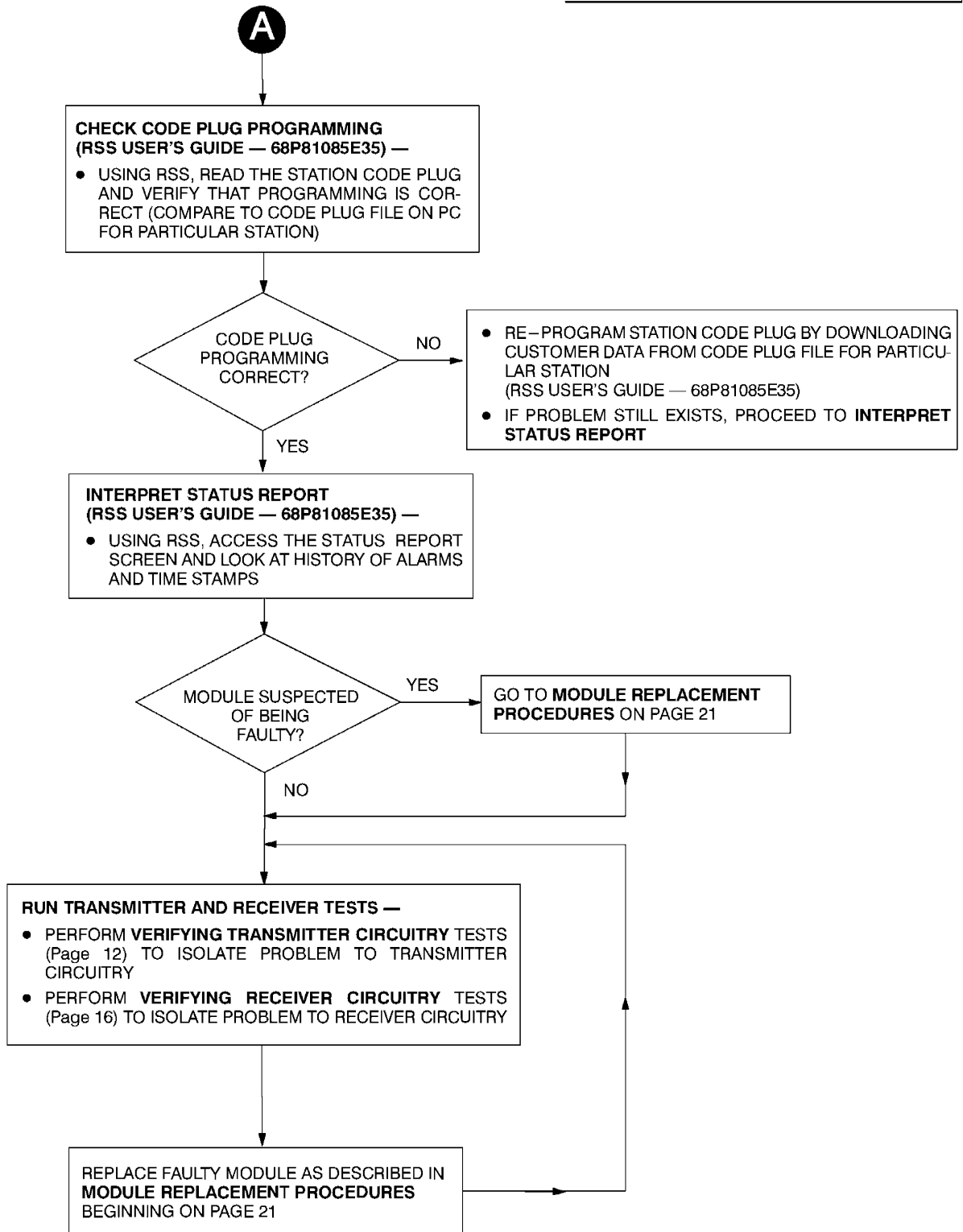

**Figure 2.** Troubleshooting Procedure 2 (Continued)



## Interpreting LED Indicators

Several LED indicators are provided on the front panels of the modules that indicate specific operating conditions. The service technician may observe these LEDs to obtain a quick status indication of the station equipment.

Figure 3 shows the location of all LED indicators provided on the station equipment. Table 1 lists each LED indicator along with a description of the status indicated by each LED.

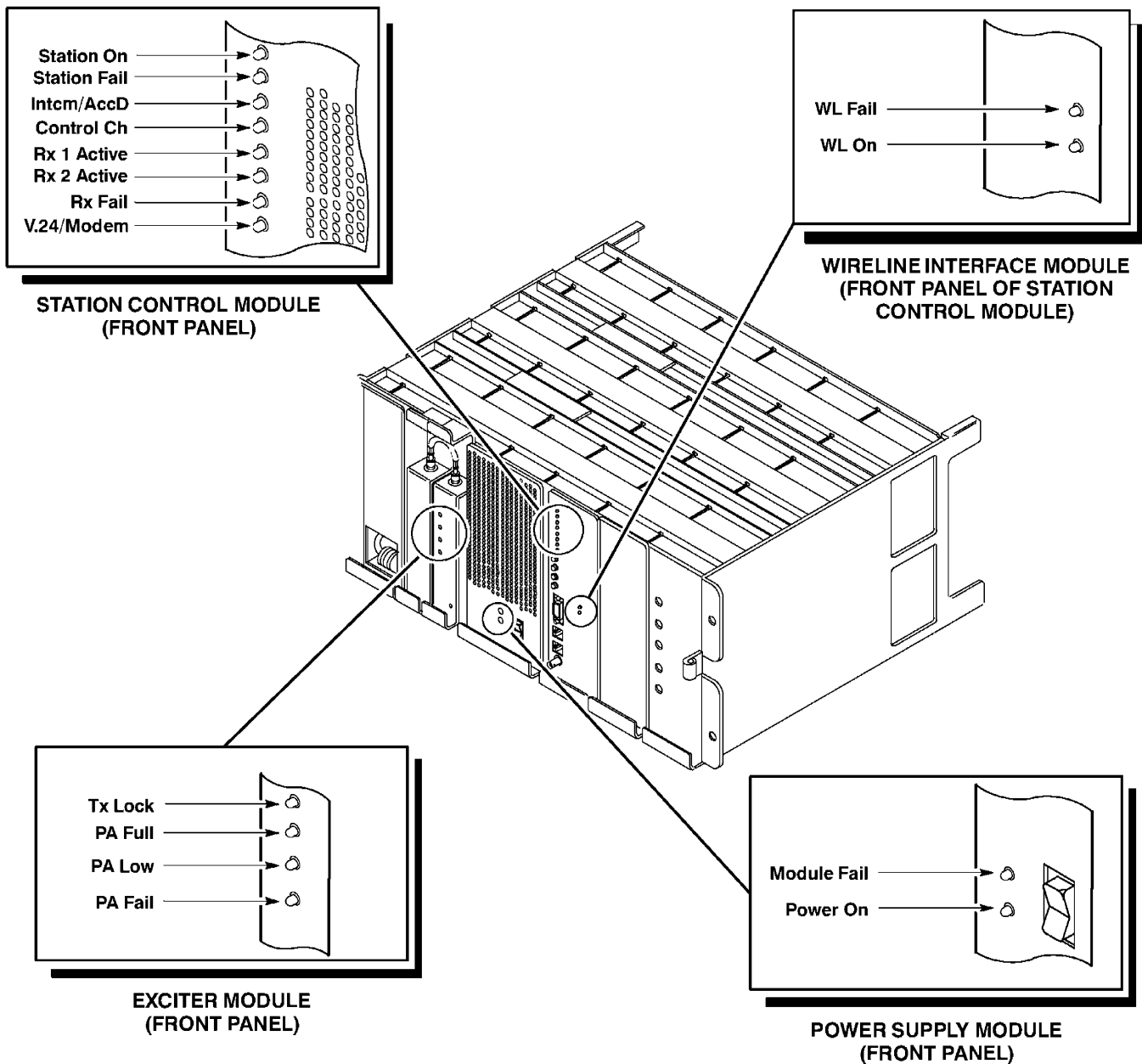

**Figure 3.** Quantar Station LED Indicators (UHF Shown)

**Table 1. Quantar Station LED Indicator Functions**

LED Location	LED Name	Status Definition
<p style="text-align: center;"><b>EXCITER MODULE</b></p>	<p style="text-align: center;"><b>TX Lock</b></p>	<ul style="list-style-type: none"> <li>– GREEN when Exciter synthesizer is locked; module fully functional.</li> <li>– OFF when:                             <ul style="list-style-type: none"> <li>synthesizer is out of lock</li> <li><b>or</b></li> <li>+5V, +14.2V, or both are absent</li> </ul> </li> </ul>
	<p style="text-align: center;"><b>PA Full</b></p>	<ul style="list-style-type: none"> <li>– GREEN when transmitter is keyed and PA output power is at expected power level (as set by technician via RSS during station alignment)</li> <li>– OFF when:                             <ul style="list-style-type: none"> <li>PA not keyed</li> <li><b>or</b></li> <li>PA keyed but PA output power is <b>not</b> at expected power level (as set by technician via RSS during station alignment)</li> </ul> </li> </ul>
	<p style="text-align: center;"><b>PA Low</b></p>	<ul style="list-style-type: none"> <li>– YELLOW when transmitter is keyed and PA output power is less than expected power level (as set by technician via RSS during station alignment) but not shut down (for example, during power cutback mode)</li> <li>– OFF when:                             <ul style="list-style-type: none"> <li>PA not keyed</li> <li><b>or</b></li> <li>PA keyed and PA output power is at expected power level (as set by technician via RSS during station alignment)</li> </ul> </li> </ul>
	<p style="text-align: center;"><b>PA Fail</b></p>	<ul style="list-style-type: none"> <li>– RED when:                             <ul style="list-style-type: none"> <li>No PA output power (for example, during PA shutdown mode); LED status is latched, thereby indicating status during current key or for previous key</li> <li><b>or</b></li> <li>(High power models only) Overdrive alarm is generated by Driver PA</li> </ul> </li> <li><b>Note:</b> Any component associated with the PA could cause LED to light. These include the +5V/IPA Module, the Driver PA Module, the Final PA Module, and rf peripherals (such as the circulator, low pass filter, etc.)</li> <li>– FLASHING when PA is in Test Mode (activated by technician via RSS; when in Test Mode, power cutback, VSWR protection, and open power loop protection are disabled)</li> <li>– OFF when PA output power is either at expected level or at specific cutback levels (any level other than shutdown); LED status is latched, thereby indicating status during current key or for previous key</li> </ul>
<p style="text-align: center;"><b>POWER SUPPLY MODULE</b></p>	<p style="text-align: center;"><b>Module Fail</b></p>	<ul style="list-style-type: none"> <li>– OFF during normal operation.</li> <li>– Lights RED when module malfunction occurs, such as shorted output, current limit exceeded, loss of communication with Station Control Module, etc.</li> </ul>
	<p style="text-align: center;"><b>Power On</b></p>	<ul style="list-style-type: none"> <li>– GREEN with ac input power present and switch turned ON</li> <li>– OFF when ac input power absent or switch turned OFF</li> </ul>

**Table 1. Quantar Station LED Indicator Functions (continued)**

LED Location	LED Name	Status Definition
<b>STATION CONTROL MODULE (SCM)</b>	<b>Station On</b>	<ul style="list-style-type: none"> <li>– GREEN when SCM fully functional</li> <li>– FLASHING when front panel switch press detected</li> <li>– OFF for SCM failure</li> </ul>
	<b>Station Fail</b>	<ul style="list-style-type: none"> <li>– RED for SCM failure</li> <li>– OFF when SCM fully functional (no failure)</li> </ul>
	<b>Intcm/Acc D</b>	<ul style="list-style-type: none"> <li>– YELLOW when station is in Intercom mode</li> <li>– FLASHING once per second when station is in Access Disable Mode</li> <li>– FLASHING twice per second when station is TX Inhibited</li> <li>– OFF when station is not in Intercom mode</li> </ul>
	<b>Control Ch</b>	<ul style="list-style-type: none"> <li>– GREEN when station is control channel (trunking systems only)</li> <li>– FLASHES each time station decodes ISW (<i>IntelliRepeater</i> systems only)</li> <li>– OFF when station is not control channel (trunking systems only)</li> </ul>
	<b>RX 1 Active</b>	<ul style="list-style-type: none"> <li>– GREEN when Station Control Board is passing audio/data (receive path un-muted) from Receiver #1; The following conditions must be met:  <ul style="list-style-type: none"> <li>Carrier at proper frequency being received</li> <li>Carrier signal level is above threshold set in codeplug</li> <li>Squelch criteria met (carrier, PL, DPL, ASTRO, secure, etc.)</li> </ul>                     (Note that squelch criteria can be manually altered via RSS for testing purposes)                 </li> <li>– OFF when above conditions are not met for Receiver #1</li> </ul>
	<b>RX 2 Active</b>	<ul style="list-style-type: none"> <li>– Indicates condition of Receiver #2; Same status definitions as RX 1 ACTIVE</li> </ul>
	<b>RX Fail</b>	<ul style="list-style-type: none"> <li>– RED when Receiver #1 and #2 are both non-functional *</li> <li>– BLINKING ONCE PER SECOND when Receiver #1 is non-functional *</li> <li>– BLINKING TWICE PER SECOND when Receiver #2 is non-functional * or when SAM Module or UHSO Module is non-functional</li> <li>– OFF when both Receiver #1 and #2 are functional * (or no receiver modules installed)</li> </ul> <p style="margin-left: 20px;">* A receiver module is considered non-functional if a failure is detected during diagnostics run at time of power-up or during normal operation.</p>
	<b>V.24/Modem</b>	<ul style="list-style-type: none"> <li>– GREEN when ASTRO Link (V.24 or ASTRO modem) between the station/receiver and infrastructure equipment is operational</li> <li>– FLASHING once per second when station/receiver is attempting to establish the analog portion of a Hybrid Link</li> <li>– FLASHING twice per second when station/receiver is attempting to establish the ASTRO Link (V.24 or ASTRO modem)</li> <li>– OFF for non-ASTRO systems or for ASTRO systems where station/receiver software does not support the LED functionality</li> </ul>
	<b>All LEDs Flashing On and Off in Unison</b>	<ul style="list-style-type: none"> <li>– Station is in Software Download mode, either initiated by the RSS or due to software failure.</li> </ul>
	<b>LEDs Flashing Up and Down in Sequential Pattern</b>	<ul style="list-style-type: none"> <li>– Station has received software files from RSS and is in process of downloading the software to FLASH memory in the Station Control Module</li> </ul>

**Table 1. Quantar Station LED Indicator Functions (continued)**

LED Location	LED Name	Status Definition
<p align="center"><b>WIRELINE INTERFACE BOARD (WIB)</b></p>	<p align="center"><b>WL On</b></p>	<p>– GREEN when WIB fully functional – OFF for WIB failure</p>
	<p align="center"><b>WL On</b></p>	<p>– GREEN when WIB fully functional – OFF for WIB failure</p>
	<p align="center"><b>Both LEDs Blinking Rapidly</b></p>	<p>– WIB is in Software Download mode (operating software is being downloaded into the FLASH memory on WIB from Station Control Module)</p>

**Notes:**

1. All LEDs momentarily light following station reset (Volume Up, Volume Down, and Intercom buttons on SCM front panel pressed simultaneously) or upon station power up.
2. If no LED indicators are on, make sure that ac power to the station power supply is present. Check the circuit breaker at the ac source. Check the ac line cord. If no problem found, suspect Power Supply Module.

## Interpreting Alarm Alert Tones

**Note:** The alarm tones may also be routed to the console (via the wireline) and transmitted over the air. Refer to the **RSS User's Guide 68P81085E35** for details on enabling/disabling these two alarm routing options.

### Introduction

Four station alarm conditions are reported with audio alert tones which are routed to the local speaker. The alarms are also entered into the alarm log which can be accessed using the RSS (refer to *RSS User's Guide 68P81085E35*).

The four alarm conditions are represented by a series of alarm tones, from a single beep to four beeps. Each beep is a 1200 Hz tone lasting 125 msec. The alarm tones occur during a repeating 10 second window, with 2 seconds between successive alarms (when more than one alarm are active). The following two examples illustrate the timing of the alarm tones.

#### Example 1: Single Alarm (#3)

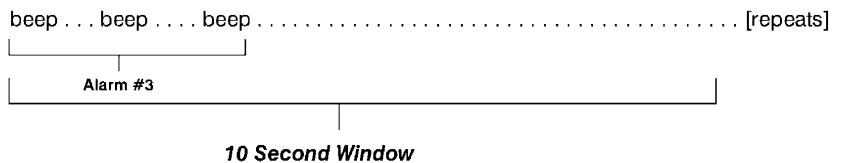

#### Example 2: Multiple Alarms (#1 and #4)

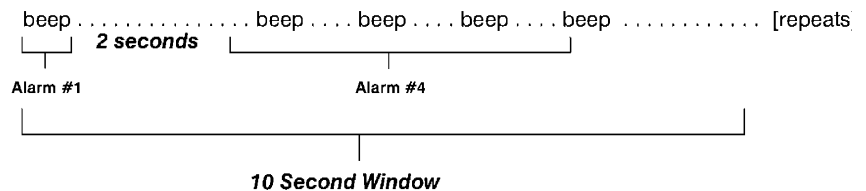

The alarm tone definitions are as follows:

Number of Beeps	Alarm Condition Name	Alarm Condition Description
1	Battery Revert	Alarm is reported when station loses ac line power and reverts to battery backup. Alarm is cleared when station receives ac power.
2	PA Fail	Alarm is reported when PA fails to key up to full output power. Alarm is cleared upon successful keyup to full power.
3	Synthesizer	Alarm is reported when either TX or RX synthesizers fail to lock. Alarm is cleared when both synthesizers lock.
4	Overvoltage	Alarm is reported when battery charging voltage is above +34.5 V (100 W stations) or +17.25 V (20 W stations). Alarm is cleared when voltage returns to normal range.

## Verifying Transmitter Circuitry

### IMPORTANT

Performing this procedure requires that the station be taken out of service. It is recommended that, unless the station is already out of service due to an equipment malfunction, this procedure be performed during off-peak hours so as to minimize the disruption of service to the system subscribers. To take the equipment out of service, use the **Access Disable** function described in the *Operation* section of this manual.

### Introduction

While most module faults can be detected by running the station diagnostics provided by the RSS, the following procedure provides a more traditional method of troubleshooting the transmitter circuitry. This procedure is useful in the event that the RSS is not at hand or for some reason cannot be utilized (PC malfunction, etc.).

This procedure allows the service technician to make minor adjustments and verify proper operation of the station transmit circuitry, including:

- Exciter Module
- Power Amplifier Module
- Power Supply Module
- 2.1 MHz reference oscillator circuitry
- Transmitter-related circuitry on the Station Control Board (SCM)

In general, the transmitter circuitry is exercised by injecting and measuring signals using a Motorola R2001 Communications Analyzer (or equivalent). Incorrect measurement values indicate a faulty module(s); measurement values within the acceptable range verify proper operation of the above listed modules and circuitry.

### Required Test Equipment

The following test equipment is required to perform the procedure:

- Motorola R2001 Communications Analyzer (or equivalent)
- Telephone-style handset with PTT switch (TMN6164 or equiv.)
- In-Line Wattmeter (Motorola Model S-1350 or equivalent)
- Dummy Load (50Ω, station wattage or higher)

### Verifying Transmitter Circuitry Procedure

- Step 1.** Connect test equipment by performing Steps 1–3 shown in Figure 4.
- Step 2.** Connect handset to RJ-11 connector on SCM front panel as shown.

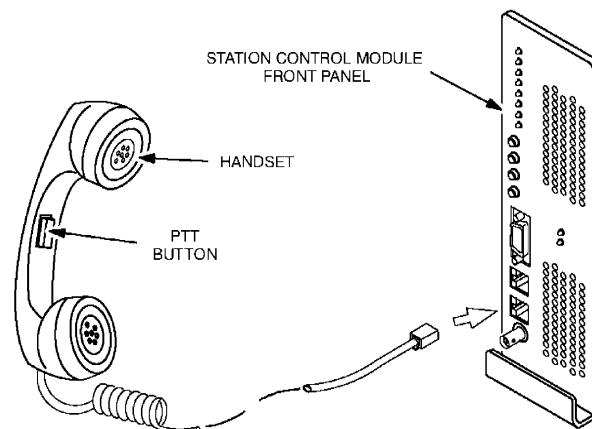

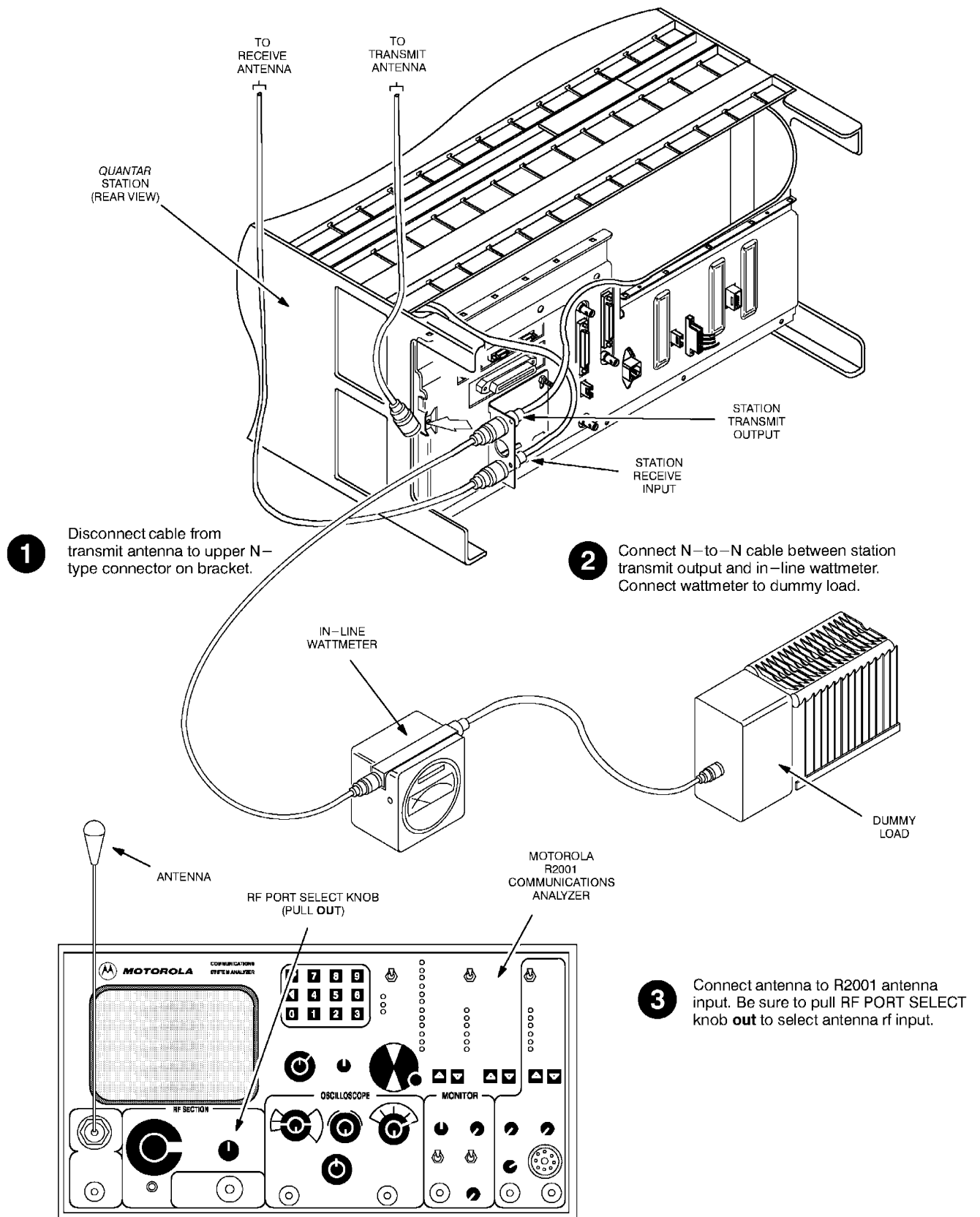

**Figure 4.** Test Equipment Setup for Verifying Transmitter Circuitry

## Verifying Transmitter Circuitry (Continued)

**Note:** Suspected faulty modules are shown ranked in order of most to least likelihood.

**Step 3.** Press the PTT button and observe LED indicators on Exciter Module front panel.

- If **PA Low** or **PA Fail** LED is lit, suspect the following:
  - Power Amplifier Module failure
  - Exciter Module failure
  - Loose or bad Exciter-to-PA rf cable
  - Loose or bad PA-to-antenna rf output cable
  - PA rf output cable not properly terminated
- If **TX Lock** LED is off, suspect the following:
  - Faulty Station Control Module
  - Faulty Exciter Module
  - Faulty backplane

**Step 4.** Measure output power by pressing the PTT button and observing reading on in-line wattmeter.

- If PA output not at proper power (as set for particular site), adjust the output power as described in the RSS User's Guide (68P81085E35).

**Step 5.** If PA output power OK, set up R2001 for spectrum analyzer display. Press the PTT button and observe the display. The display should look similar to:

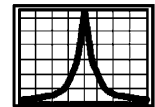

- If the display shows multiple carriers evenly spaced about the carrier, suspect a faulty PA module or +5V/IPA Module
- If the display shows a solid carrier but off frequency, suspect the following:
  - Faulty Exciter or Station Control Module
  - Faulty external 5 MHz reference source
- If the display shows a single carrier moving erratically, suspect:
  - Faulty Station Control Module
  - Faulty Exciter Module
  - Faulty PA Module

**Note:** Suspected faulty modules are shown ranked in order of most to least likelihood.

(continued on page 15)



---

## Verifying Transmitter Circuitry (Continued)

**Step 6.** If display OK, set up R2001 to display modulation. Using the handset, push the PTT button and speak into the mouthpiece. Verify that the display shows:

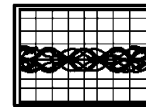

- If proper display is not obtained, suspect faulty SCM or Exciter Module.

**Step 7.** Set the R2001 for GEN/MON MTR. Press the PTT button and speak loudly in the mouthpiece to cause maximum deviation. Display should read  $\pm 5$  kHz maximum.

- If proper display is not obtained, suspect faulty SCM or Exciter Module.

**Step 8.** This completes the **Verifying Transmitter Circuitry** test procedure. If all displays and measurements are correct, the transmitter circuitry may be considered to be operating properly. Remove test equipment, restore the station to normal service, and return to the troubleshooting flow chart to resume troubleshooting sequence.

## Verifying Receiver Circuitry (Analog Capable Stations)

### IMPORTANT

Performing this procedure requires that the station be taken out of service. It is recommended that, unless the station is already out of service due to an equipment malfunction, this procedure be performed during off-peak hours so as to minimize the disruption of service to the system subscribers. To take the equipment out of service, use the **Access Disable** function described in the *Operation* section of this manual.

### IMPORTANT

Note that if station operates as a repeater the transmit output from the station must be connected to a dummy load to prevent over-the-air broadcast during receiver testing.

### Introduction

While most module faults can be detected by running the station diagnostics provided by the RSS, the following procedure provides a more traditional method of troubleshooting the receiver circuitry. This procedure is useful in the event that the RSS is not at hand or for some reason cannot be utilized (PC malfunction, etc.).

This procedure allows the service technician to make minor adjustments and verify proper operation of the station receive circuitry, including:

- Receiver Module
- Power Supply Module
- 2.1 MHz reference oscillator circuitry
- Receiver-related circuitry in the Station Control Module (SCM)

In general, the receiver circuitry is exercised by injecting and measuring signals using a Motorola R2001 Communications Analyzer (or equivalent). Incorrect measurement values indicate a faulty module(s); measurement values within the acceptable range verify proper operation of the above listed modules and circuitry.

### Required Test Equipment

The following test equipment is required to perform the procedure:

- Motorola R2001 Communications Analyzer (or equivalent)
- Telephone-style handset with PTT switch (TMN6164 or similar)
- Female N-type to Female N-type coaxial cable
- RJ-11 to BNC cable
- Dummy Load (50Ω, station wattage or higher) required for repeater stations only

### Verifying Receiver Circuitry Procedure

- Step 1.** Connect test equipment by performing Steps 1–3 shown in Figure 5.
- Step 2.** Disable PL and carrier squelch by repeatedly pressing the **PL/CSQ/Off** button until receiver noise is heard thru the handset (or external or internal speaker). If no audio is heard, suspect the following:
  - Faulty Receiver Module
  - Faulty Station Control Module
  - R2001 is outputting a carrier signal
- Step 3.** Set R2001 to generate a .5 μV (–113 dBm) FM signal at the *Quantar* receiver frequency, modulated by a 1 kHz tone at 3 kHz deviation. The 1 kHz tone should be audible thru the handset (or internal or external speaker). If no audio is heard, suspect the following:
  - Faulty Station Control Module (2.1 MHz reference)
  - Faulty Receiver Module
  - Faulty antenna-to-Receiver preselector rf cable
  - Faulty R2001-to-station rf cable

(continued on page 18)

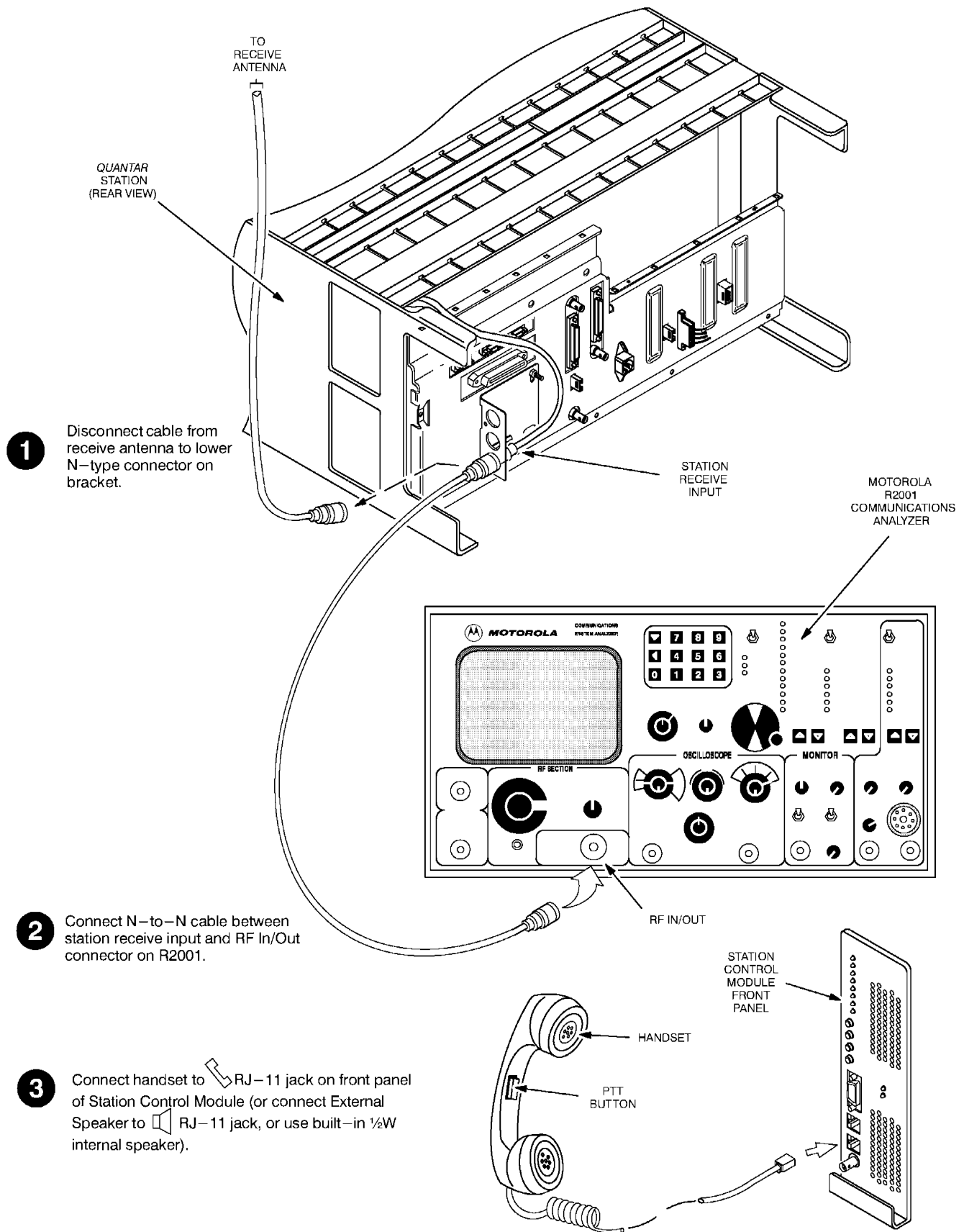

**Figure 5.** Test Equipment Setup for Verifying Receiver Circuitry

## Verifying Receiver Circuitry (Continued)

**Step 4.** If audio is heard, connect the HANDSET RJ-11 jack to the Oscilloscope input BNC connector, as shown below:

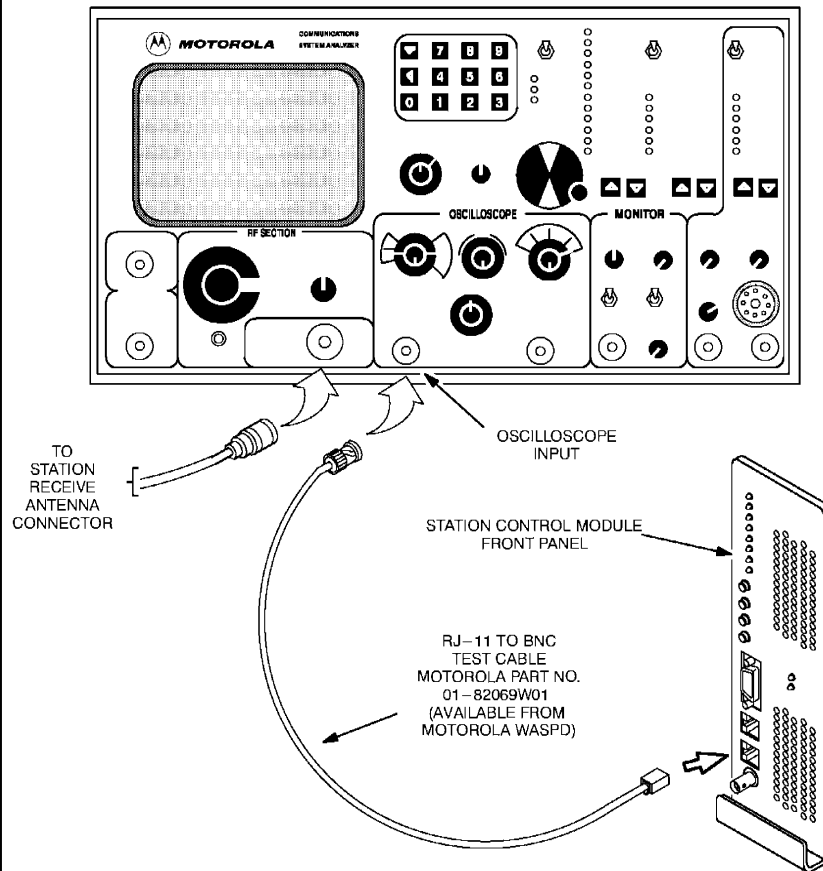

**Step 5.** Use **Volume Up** button to increase volume to maximum. Measure the audio level using the R2001.

- Audio level should measure approximately .75 to 1.5 V p-p. If not, suspect faulty SCM.

**Step 6.** Change R2001 injection signal level to:

**VHF:** .25  $\mu$ V (-119 dBm)

**UHF:** .35  $\mu$ V (-116 dBm)

**800, 900:** .30  $\mu$ V (-117.5 dBm)

**Step 7.** Measure the receiver SINAD. The value should read 12 dB or greater. If not, tune the preselector (VHF and UHF only) and recheck SINAD. If 12 dB SINAD cannot be achieved, replace the Receiver Module.

**Step 8.** This completes the **Verifying Receiver Circuitry** test procedure. If all displays and measurements are correct, the receiver circuitry may be considered to be operating properly. Remove test equipment, restore the station to normal service, and return to the troubleshooting flow chart to resume troubleshooting sequence.

**Note:** To measure SINAD, the station must be programmed for mixed mode Analog/Digital operation. Incorrect reading will result if programmed for Digital Only operation.

**Note:** For VHF and UHF stations only, refer to 5. **Preselector Field tuning Procedure** in this section for procedures to tune the receiver preselector.

## Verifying Receiver Circuitry (Digital Only Stations)

### IMPORTANT

Performing this procedure requires that the station be taken out of service. It is recommended that, unless the station is already out of service due to an equipment malfunction, this procedure be performed during off-peak hours so as to minimize the disruption of service to the system subscribers. To take the equipment out of service, use the **Access Disable** function described in the *Operation* section of this manual.

### IMPORTANT

Note that if station operates as a repeater the transmit output from the station must be connected to a dummy load to prevent over-the-air broadcast during receiver testing.

### Introduction

While most module faults can be detected by running the station diagnostics provided by the RSS, the following procedure provides a more traditional method of troubleshooting the receiver circuitry.

This procedure allows the service technician to make minor adjustments and verify proper operation of the station receive circuitry, including:

- Receiver Module
- Power Supply Module
- 2.1 MHz reference oscillator circuitry
- Receiver-related circuitry in the Station Control Module (SCM)

In general, the receiver circuitry is exercised by injecting and measuring test pattern signals using a Motorola R2670 Communications Analyzer (or equivalent) and analyzing the Bit Error Rate using the RSS. Incorrect measurement values indicate a faulty module(s); measurement values within the acceptable range verify proper operation of the above listed modules and circuitry.

### Required Test Equipment

The following test equipment is required to perform the procedure:

- Motorola R2670 Communications Analyzer with *ASTRO CAI* Option (or equivalent)
- PC running Radio Service Software (RSS) program
- Female N-type to Female N-type coaxial cable
- Dummy Load (50Ω, station wattage or higher) required for repeater stations only

### Verifying Receiver Circuitry Procedure

- Step 1.** Proceed to the procedure *ASTRO Bit Error Rates Reports* (located in Chapter 4 of the *RSS User's Guide 68P81085E35*). Follow the instructions for setting up the test equipment and initiating a BER report using the RSS.
- Step 2.** If the BER reading is above 5%, suspect the following:
- Faulty Station Control Module (2.1 MHz reference)
  - Faulty Receiver Module
  - Faulty antenna-to-Receiver preselector rf cable
  - Faulty R2670-to-station rf cable
- Step 3.** Change R2670 injection signal level to:
- VHF:** .25 μV (−119 dBm)  
**UHF:** .35 μV (−116 dBm)  
**800, 900:** .30 μV (−117.5 dBm)

(continued on page 20)

---

## Verifying Receiver Circuitry (Analog Capable Stations) (Continued)

**Note:** For VHF and UHF stations only, refer to **5. Preselector Field tuning Procedure** in this section for procedures to tune the receiver preselector.

- Step 4.** Note the receiver BER reading. The BER reading should be 5% or less. If not, tune the preselector (VHF and UHF only) and recheck the BER reading. If a reading of 5% or less cannot be achieved, replace the Receiver Module.
- Step 5.** This completes the **Verifying Receiver Circuitry** test procedure. If all displays and measurements are correct, the receiver circuitry may be considered to be operating properly. Remove test equipment, restore the station to normal service, and return to the troubleshooting flow chart to resume troubleshooting sequence.

## 4 MODULE REPLACEMENT PROCEDURES

Station modules suspected of being faulty must be replaced with known good modules to restore the station to proper operation. The following procedures provide instructions for replacing each of the station modules and performing any required post-replacement adjustments or programming.

### General Replacement Information



#### WARNING

When wearing Conductive Wrist Strap, be careful near sources of high voltage. The good ground provided by the wrist strap will also increase the danger of lethal shock from accidentally touching high voltage sources.



#### CAUTION

**DO NOT** insert or remove station modules with power applied. This may result in damage to the modules.

### Anti-Static Precaution

The station circuitry contains many C-MOS and other static-sensitive devices. When servicing the equipment, you must take precautionary steps to prevent damage to the modules from static discharge. Complete information on prevention of static protection is provided in Motorola publication 68P81106E84, available through Motorola National Parts. Some additional precautions are as follows:

- A wrist strap (Motorola Part No. RSX4015A, or equivalent) should be worn while servicing to minimize static buildup. Banana jacks are built into the station cage for connection of the wrist strap.

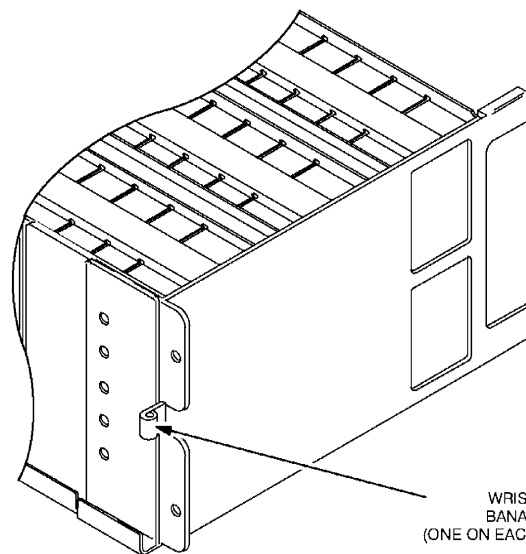

- **Do not** insert or remove modules with power applied. Always turn off the station using the On/Off switch located on the front of the Power Supply Module before inserting or removing modules.
- All spare modules should be kept in a conductive bag for storage and transporting. When shipping modules to the repair depot, always pack in conductive material.

---

## General Replacement Information (Continued)

### ***Care of Gold–Plated Connector Contacts***

The connections between the modules and the station backplane board are made with gold-plated card edge connector contacts to provide maximum reliability. Gold-plated materials do not form a non-conductive oxide layer, and therefore should not require cleaning under normal conditions.

When the modules have been subjected to many extraction/insertion cycles, or if the station is operated in a dusty environment, the contacts may require cleaning. **Do not** use an eraser or any type of abrasive substance to clean either the module card-edge connectors or the backplane connector contacts. Any type of abrasive cleaning (typically employed for cleaning non gold-plated contacts) can result in the removal of the gold plating or bending of the connector contacts.

If cleaning of the gold-plated contacts is required, use a soft cloth dampened with alcohol to lightly wipe the contacts. Be sure not to touch the contact surfaces with your fingers, as finger oils and salts can contaminate the contact surfaces.

### ***Cleaning Module Rails***

After a few module extraction/insertion cycles, wipe the module rails with a soft cloth to remove any oxidation or foreign material. This ensures a good ground connection between the module and the cage.

### ***Power Down Station Before Removing/Inserting Modules***

Before removing or inserting a module into the station cage and engaging the backplane connector, be sure to turn off the station power using the Power Supply Module On/Off switch.

**Important!** If the station is equipped with battery backup, turning the On/Off switch to OFF **will not** turn the station off. You must also disconnect the battery revert cable from the station backplane. Remember to reconnect the battery cable before restoring the station to operation.

### ***Validating Repairs***

After replacing a faulty module with a known good module, perform one of the following tests to validate the repair before leaving the site.

- If the faulty module was detected as the result of running station diagnostics via the RSS, run the diagnostics again after the repair is made to ensure that the replacement module passes all diagnostic tests.
- If the faulty module was detected by an operational failure, perform the operation to ensure that the repair corrected the reported/detected failure.



---

## Replacing Power Amplifier Module

### **Replacement Procedure**

- Step 1.** Turn off station power (refer to page 22).
- Step 2.** Using a Torx #15 driver, remove anti-vibration screw(s) (if installed) from top and/or bottom of module front panel.
- Step 3.** Disconnect mini-UHF connector on rf cable connecting Exciter Module to Power Amplifier Module.
- Step 4.** Slide the module out to the first stop. Disconnect the N-type connector (rf output from the module) from the lower left side of module.
- Step 5.** Remove faulty module from cage.
- Step 6.** Install replacement Power Amplifier Module by sliding module into cage (about 2 inches from full insertion). Connect the rf output cable to the N-type connector at the lower left side of the module.
- Step 7.** Slide the module in completely and firmly seat the module connector into the backplane. (**Do not** slam the module against the backplane or push any harder than necessary to seat the connectors.) Now reconnect the rf cable from the Exciter Module.
- Step 8.** Restore power to the station.

### **Post-Replacement Optimization Procedure**

Perform the *Power Output* alignment procedure located in the RSS User's Guide (68P81085E35).

## Replacing Exciter Module

**Note** The replacement board must have the same model number as the faulty board (e.g., TLF6920). If it does not, contact the System Support Center at 1-800-221-7144 for instructions on how to proceed.

**Note** If the existing EPROM is faulty, contact the System Support Center at 1-800-221-7144 to obtain replacement part. The version of software contained in the replacement device must match that of the faulty device.

**Note** Use an IC Extraction Tool (Motorola Part No. 01-80386A04) to remove the firmware devices.

### Replacement Procedure

- Step 1.** Turn off station power (refer to page 22).
- Step 2.** Using a Torx #15 driver, remove anti-vibration screw(s) (if installed) from top and/or bottom of module front panel.
- Step 3.** Disconnect mini-UHF connector on rf cable connecting Power Amplifier Module to Exciter Module.
- Step 4.** Remove faulty module from cage.
- Step 5.** The Exciter Board software must now be removed from the old board and installed onto the replacement board. The software is contained on a single EPROM. You must remove the EPROM from the replacement board and replace it with the EPROM from the old board. The following illustration shows the location of the EPROM.

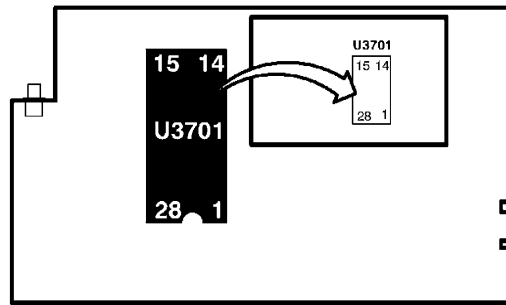

- Step 6.** Install replacement Exciter Module by sliding module into cage and firmly seating the module connector into the backplane. (**Do not** slam the module against the backplane or push any harder than necessary to seat the connectors.) Now reconnect the rf cable from the Power Amplifier Module.
- Step 7.** Restore power to the station.

### Post-Replacement Optimization Procedure

- Step 1.** Perform the *TX Deviation Gain Adjust* alignment procedure located in the RSS User's Guide (68P81085E35).
- Step 2.** Perform the *Reference Modulation* alignment procedure located in the RSS User's Guide (68P81085E35).
- Step 3.** For *ASTRO* Simulcast systems only, perform the *ASTRO/Simulcast Launch Time Offset* alignment procedure located in the RSS User's Guide (68P81085E35).

---

## Replacing Power Supply Module

### *Replacement Procedure*

- Step 1.** Turn off station power (refer to page 22).
- Step 2.** Using a Torx #15 driver, remove anti-vibration screw(s) (if installed) from top and/or bottom of module front panel.
- Step 3.** Remove faulty module from cage.
- Step 4.** Install replacement Power Supply Module by sliding module into cage and firmly seating the module connector into the backplane. (**Do not** slam the module against the backplane or push any harder than necessary to seat the connectors.)
- Step 5.** Restore power to the station.

### *Post-Replacement Optimization Procedure*

Replacement Power Supply Modules are factory aligned. Therefore, no post-replacement optimization is required for this module.

## Replacing Station Control Module (all except modules in IntelliRepeater Ethernet Networks)

**Note** The replacement board must have the same model number as the faulty board (e.g., CLN6961). If it does not, contact the System Support Center at 1-800-221-7144 for instructions on how to proceed.

**Note** If the existing EPROM or FLASH SIMM is faulty, contact the System Support Center at 1-800-221-7144 to obtain replacement parts. The version of software contained in the replacement devices must match that of the faulty devices.

**Note** Use an IC Extraction Tool (Motorola Part No. 01-80386A04) to remove the firmware devices.

### Replacement Procedure

- Step 1.** If the module is capable of communicating with the RSS, connect the PC to the RSS port, start the RSS program, and save the codeplug from the station to a file on the PC hard disk. This will allow the codeplug information to be downloaded to the codeplug located on the replacement Station Control Board. If the module cannot communicate with the RSS, an archive file (if available) of the particular station codeplug may be downloaded. If no archive codeplug file exists, you must program the codeplug as described in the RSS User's Guide (68P81085E35).
- Step 2.** Turn off station power (refer to page 22).
- Step 3.** Using a Torx #15 driver, remove front panel and Station Control Board as described in Figure 6.
- Step 4.** The Station Control Board software must now be removed from the old board and installed onto the replacement board. The software is contained on either two or four EPROMs (earlier version boards) or a single FLASH SIMM (later version boards). You must remove the EPROMs or FLASH SIMM from the replacement board and install the EPROMs or FLASH SIMM from the old board. The following illustrations show the locations of the EPROMs and FLASH SIMM.

Software on Two EPROMs

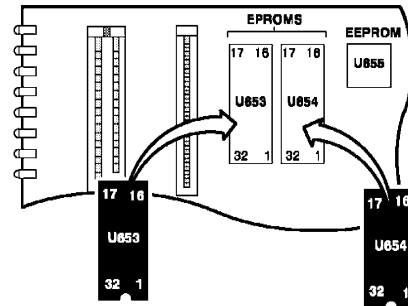

Software on Four EPROMs

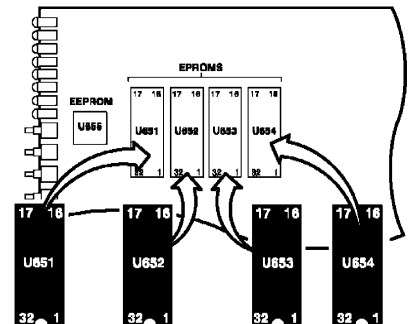

## Replacing Station Control Module (Conventional/6809) (Continued)

### Replacement Procedure (continued)

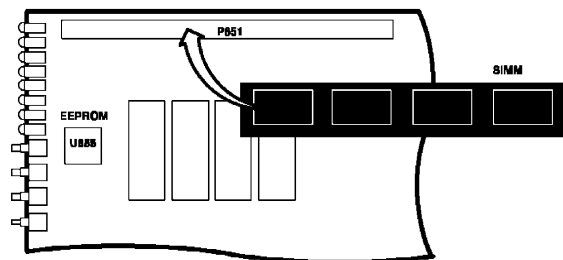

Software on  
Single FLASH  
SIMM

**Note:** When inserting Station Control Board into cage, place your thumbs on the BNC and D-type connectors and firmly push the board into the backplane connector.

- Step 5.** Install replacement Station Control Board by sliding board into cage and firmly seating the board card-edge connectors into the backplane. (**Do not** slam the board against the backplane or push any harder than necessary to seat the connectors.)
- Step 6.** Replace the front panel by pressing it into place and replacing the two screws. Be sure the 2-wire cable from the local speaker is connected to the 3-pin connector at the bottom front of the Station Control Board. If the connector is not keyed (earlier models), you may connect the 3-pin connector in either polarity.
- Step 7.** Restore power to the station.

### Post-Replacement Optimization Procedure

- Step 1.** Replacement Station Control Modules are shipped with default data programmed into the codeplug (EEPROM located on board). After replacing a Station Control Board, you must download codeplug data (unique to the particular station) to the replacement board codeplug. Simply retrieve the file from your archive and follow the instructions in the RSS User's Guide (68P81085E35) for saving data to the codeplug. Note that if no archive codeplug file exists, you may create a new codeplug by copying the **training.cp** codeplug file (supplied with the RSS) and then program it as necessary to meet the particular station's requirements.
- Step 2.** Calibrate the reference oscillator (station reference) by performing the procedure in the Routine Maintenance section of this manual.
- Step 3.** Perform the alignment procedures listed in the sidebar as described in the RSS User's Guide (68P81085E35).

#### Alignment Procedures

- RX Wireline
- TX Wireline
- Squelch Adjust
- Battery Equalization (if required)
- Power Output
- Tx Deviation Gain Adjust
- Reference Modulation

For *ASTRO* stations, also perform RSSI and Simulcast/ASTRO Launch Time Offset alignment.

For 6809 Trunking stations, also perform TDATA alignment.

## Replacing Station Control Module (for modules in IntelliRepeater Ethernet Networks)

**Note** If the Physical Address and/or the IP Address cannot be read, contact the System Support Center at 1-800-221-7144.

**Note** Use an IC Extraction Tool (Motorola Part No. 01-80386A04) to remove the firmware devices.

### Replacement Procedure

- Step 1.** If the module is capable of communicating with the RSS, connect the PC to the RSS port, start the RSS program, and save the codeplug from the station to a file on the PC hard disk. This will allow the codeplug information to be downloaded to the codeplug located on the replacement Station Control Board. If the module cannot communicate with the RSS, an archive file (if available) of the particular station codeplug may be downloaded. If no archive codeplug file exists, you must program the codeplug as described in the RSS User's Guide (68P81085E35).
- Step 2.** Using the RSS, read the *IP Address* and *Physical Address* assigned to the station and jot them down. (From the RSS **Main Menu**, go to **Service:Ethernet Parameters** to read the *IP Address* and the *Physical Address*.)
- Step 3.** Turn off station power (refer to page 22).
- Step 4.** Disconnect the station from the Ethernet LAN as described below.

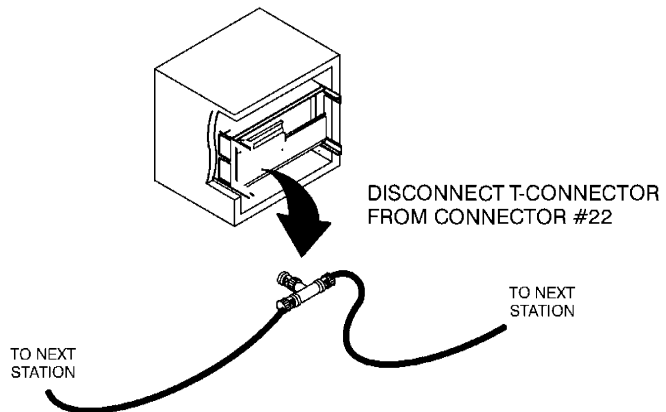

- Step 5.** Using a Torx #15 driver, remove front panel and Station Control Board as described in Figure 6.
- Step 6.** The Station Control Board software must now be removed from the old board and installed onto the replacement board. The software is contained on a single FLASH SIMM. You must remove the FLASH SIMM from the replacement board and install the FLASH SIMM from the old board. The following illustration shows the location of the FLASH SIMM.

## Replacing Station Control Module (for modules in IntelliRepeater Ethernet Networks) (Continued)

**Note** If the existing FLASH SIMM is faulty, contact the System Support Center at 1-800-221-7144 to obtain a replacement part.

**Note** The replacement board must have the same model number as the faulty board (e.g., CLN6960). If it does not, contact the System Support Center at 1-800-221-7144 for instructions on how to proceed.

**Note:** When inserting Station Control Board into cage, place your thumbs on the BNC and D-type connectors and firmly push the board into the backplane connector.

### Alignment Procedures

- RX Wireline
- TX Wireline
- Squelch Adjust
- Battery Equalization (if required)
- Power Output
- Tx Deviation Gain Adjust
- Reference Modulation

For ASTRO stations, also perform RSSI and Simulcast/ASTRO Launch Time Offset alignment.

### Replacement Procedure (continued)

**Software on Single FLASH SIMM**

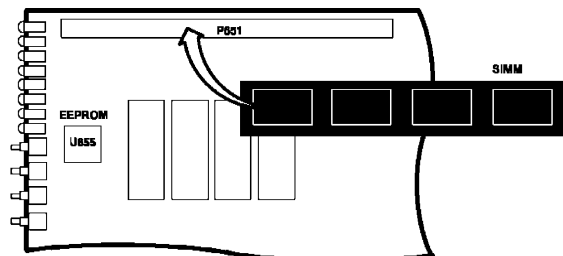

- Step 7.** Install replacement Station Control Board by sliding board into cage and firmly seating the board card-edge connectors into the backplane. (**Do not** slam the board against the backplane or push any harder than necessary to seat the connectors.)
- Step 8.** Replace the front panel by pressing it into place and replacing the two screws. Be sure the 2-wire cable from the local speaker is connected to the 3-pin connector at the bottom front of the Station Control Board. If the connector is not keyed (earlier models), you may connect the 3-pin connector in either polarity.
- Step 9.** Restore power to the station.

### Post-Replacement Optimization Procedure

- Step 1.** Replacement Station Control Modules are shipped with default data programmed into the codeplug (EEPROM located on board). After replacing a Station Control Board, you must download codeplug data (unique to the particular station) to the replacement board codeplug. Simply retrieve the file from your archive and follow the instructions in the RSS User's Guide (68P81085E35) for saving data to the codeplug. Note that if no archive codeplug file exists, you may copy a codeplug from another station at the site and save it to this station.  
**Important!** When the RSS prompts you to "Crossload" the other stations at the site, answer **NO**.
- Step 2.** Using the RSS, navigate to **Service:Ethernet Parameters** and change the **IP Address** and **Physical Address** to the addresses you read in Step 2 on page 28.
- Step 3.** Calibrate the reference oscillator (station reference) by performing the procedure in the Routine Maintenance section of this manual.
- Step 4.** Perform the alignment procedures listed in the sidebar as described in the RSS User's Guide (68P81085E35).
- Step 5.** Turn off station power (refer to page 22).
- Step 6.** Reconnect the T-connector from the Ethernet LAN.
- Step 7.** Restore power to the station.

1

Remove the two screws from top and bottom of Station Control Module front panel.

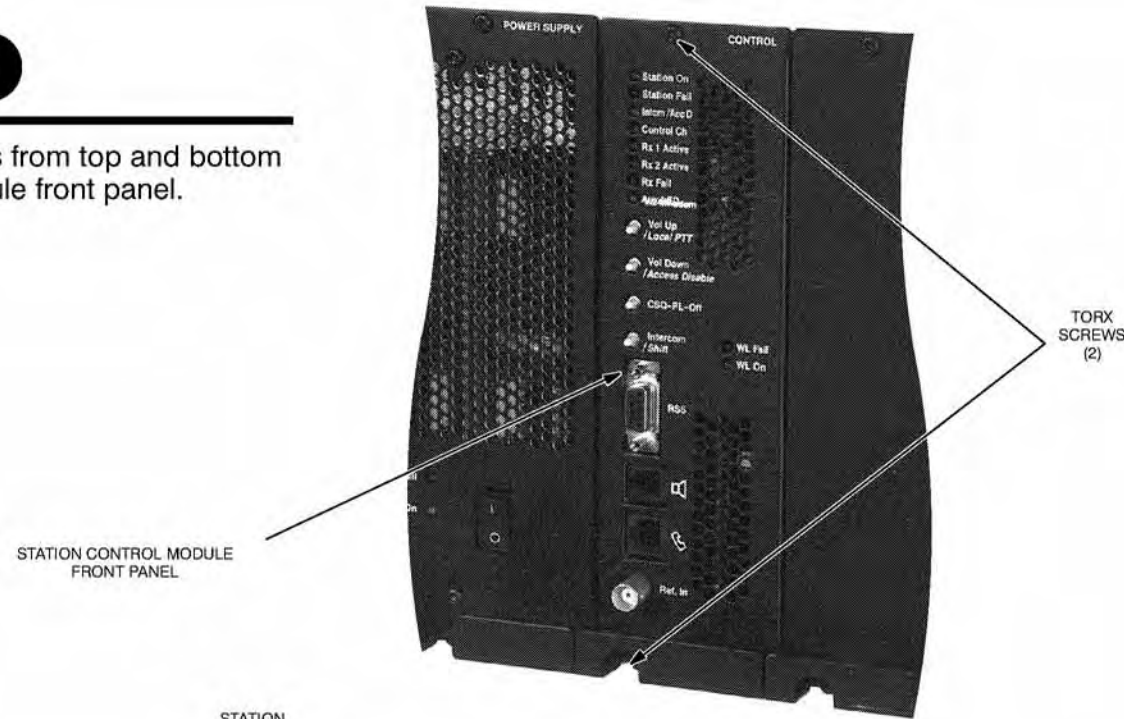

2

Partially remove front panel and position the board extraction tab on the bottom rail of the cage and slide the panel to the left until the lip of the tab is positioned behind the cutout in the Station Control Board.

EXTRACTOR TAB BEHIND BOARD CUTOUT

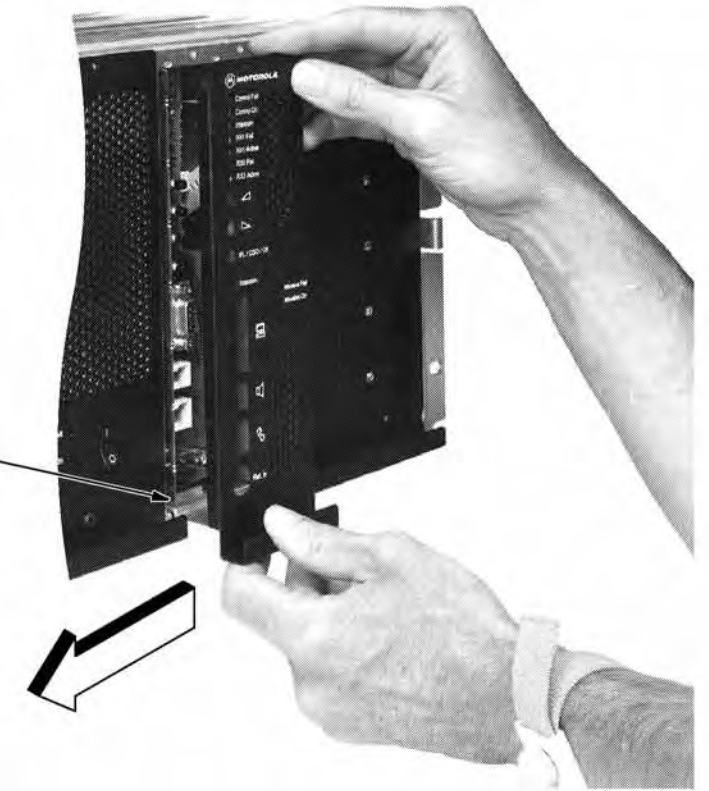

STATION CONTROL BOARD

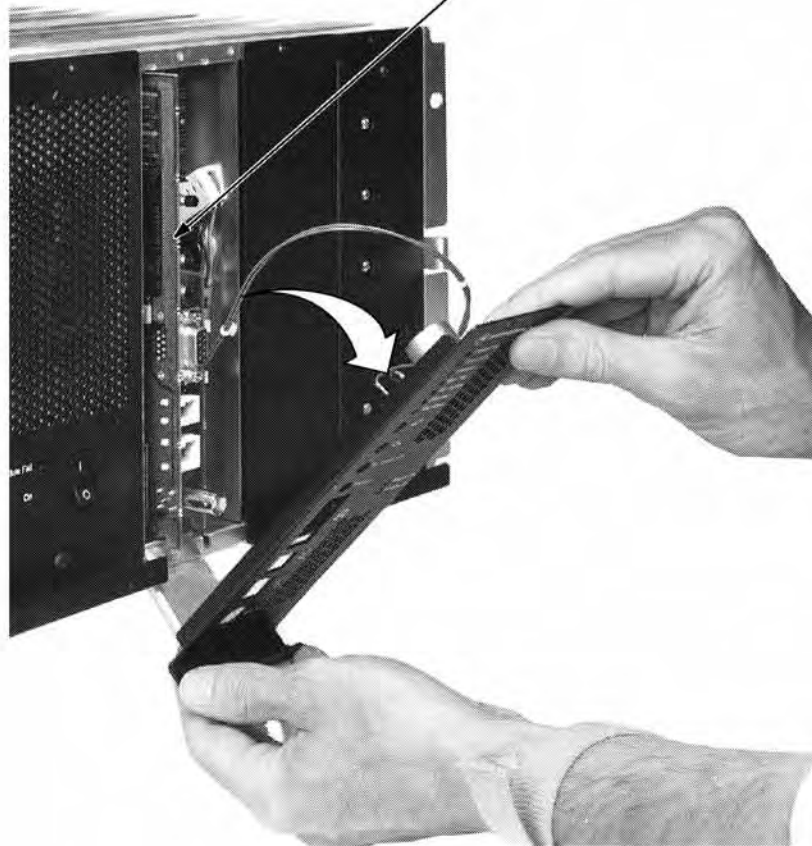

3

Tip back on the panel to pry the Station Control Board out of the backplane connectors.

4

Remove Station Control Board from cage.

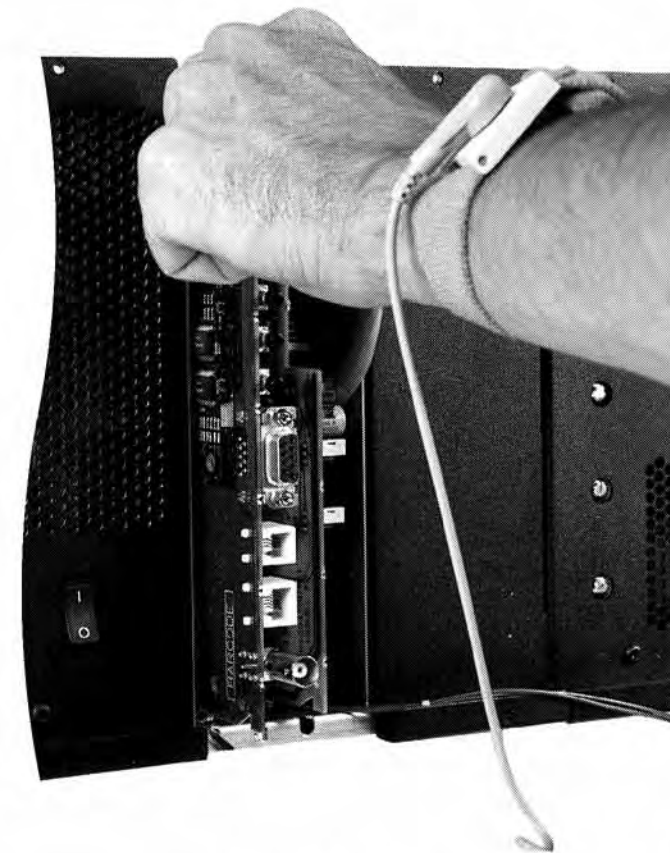

Figure 6. Removal Procedure for Station Control Board (Quantar VHF Station Shown)



## Replacing Wireline Interface Board

**Note** A later model board (CLNxxxx) can be used to replace both later model boards and earlier model boards (TRNxxxx). However, earlier model boards cannot be used to replace later model boards. (Later model boards support either EPROMs or FLASH; earlier model boards support only EPROMs.)

**Note** If the existing EPROM or FLASH SIMM is faulty, contact the System Support Center at 1-800-221-7144 to obtain replacement parts. The version of software contained in the replacement devices must match that of the faulty devices.

**Note** Use an IC Extraction Tool (Motorola Part No. 01-80386A04) to remove the firmware devices.

### Replacement Procedure

- Step 1.** Turn off station power (refer to page 22).
- Step 2.** Using a Torx #15 driver, remove anti-vibration screw(s) (if installed) from top and/or bottom of module front panel.
- Step 3.** Remove Station Control Module front panel and Wireline Interface Board as described in Figure 6.
- Step 4.** Set all jumpers on replacement board to match those on the faulty board. These include input/output impedance matching jumpers, 2-wire/4-wire select jumper, and dc remote control selection jumpers.
- Step 5.** The Wireline Board software must now be removed from the old board and installed onto the replacement board. The software is contained on either two EPROMs (earlier version boards) or two FLASH ICs (later version boards). You must remove the EPROMs or FLASH ICs from the replacement board and install the EPROMs or FLASH ICs from the old board. The following illustration shows the locations of the EPROMs and FLASH ICs.

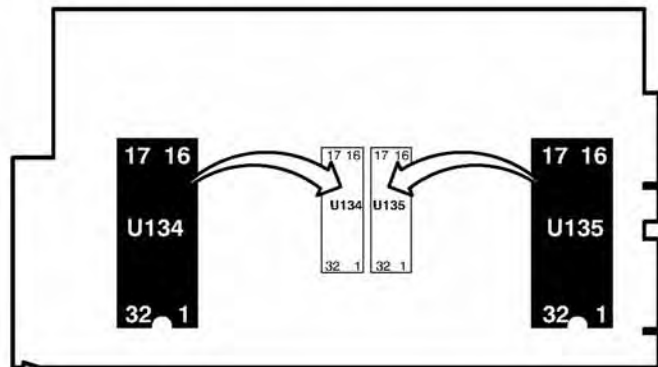

- Step 6.** Install replacement Wireline Interface Board by sliding board into cage and firmly seating the board card-edge connectors into the backplane. (**Do not** slam the board against the backplane or push any harder than necessary to seat the connectors.)
- Step 7.** Replace the front panel by pressing it into place and replacing the two screws. Be sure the 2-wire cable from the local speaker is connected to the 3-pin connector at the bottom front of the Station Control Board. If the connector is not keyed (earlier models), you may connect the 3-pin connector in either polarity.
- Step 8.** Restore power to the station.

### Post-Replacement Optimization Procedure

Perform the *Rx Wireline* and *Tx Wireline* adjustment procedures located in the RSS User's Guide (68P81085E35).

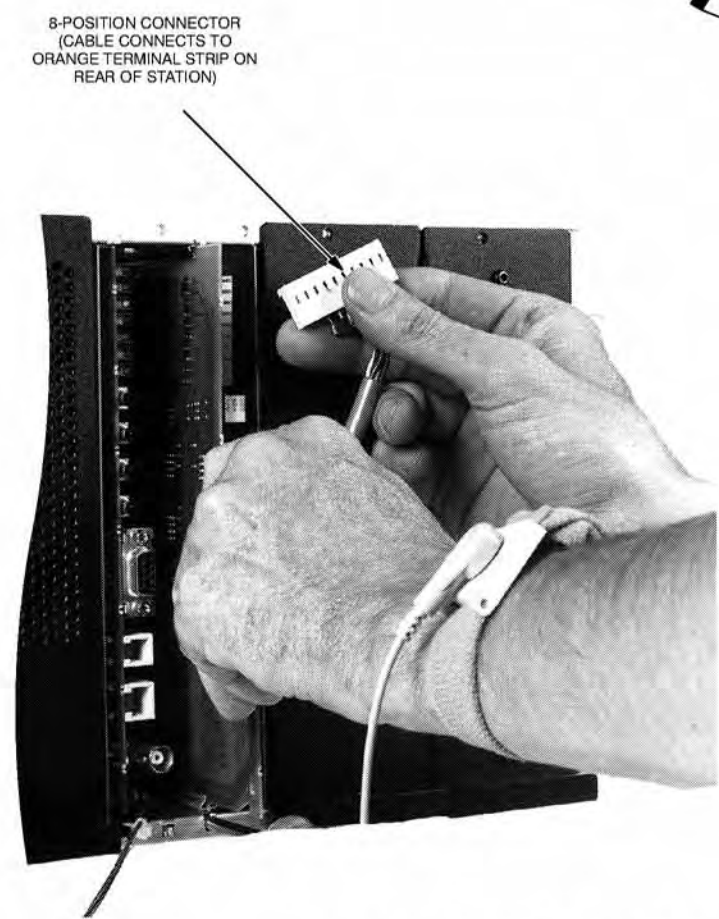
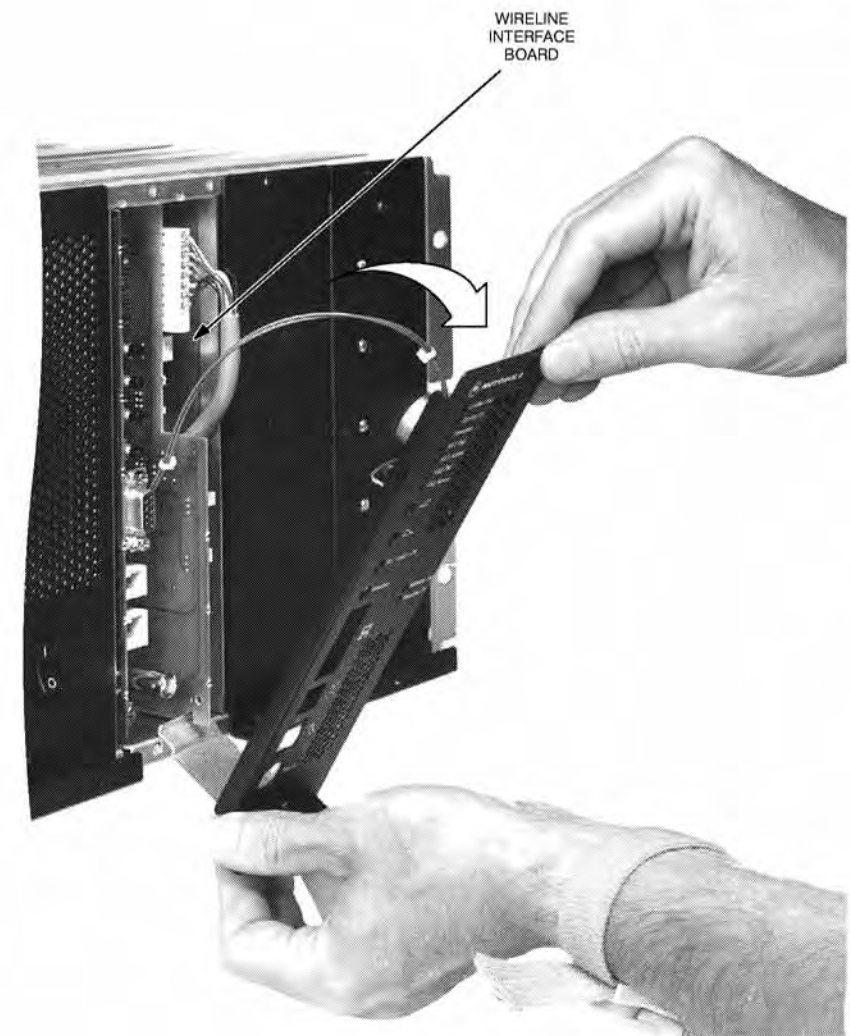
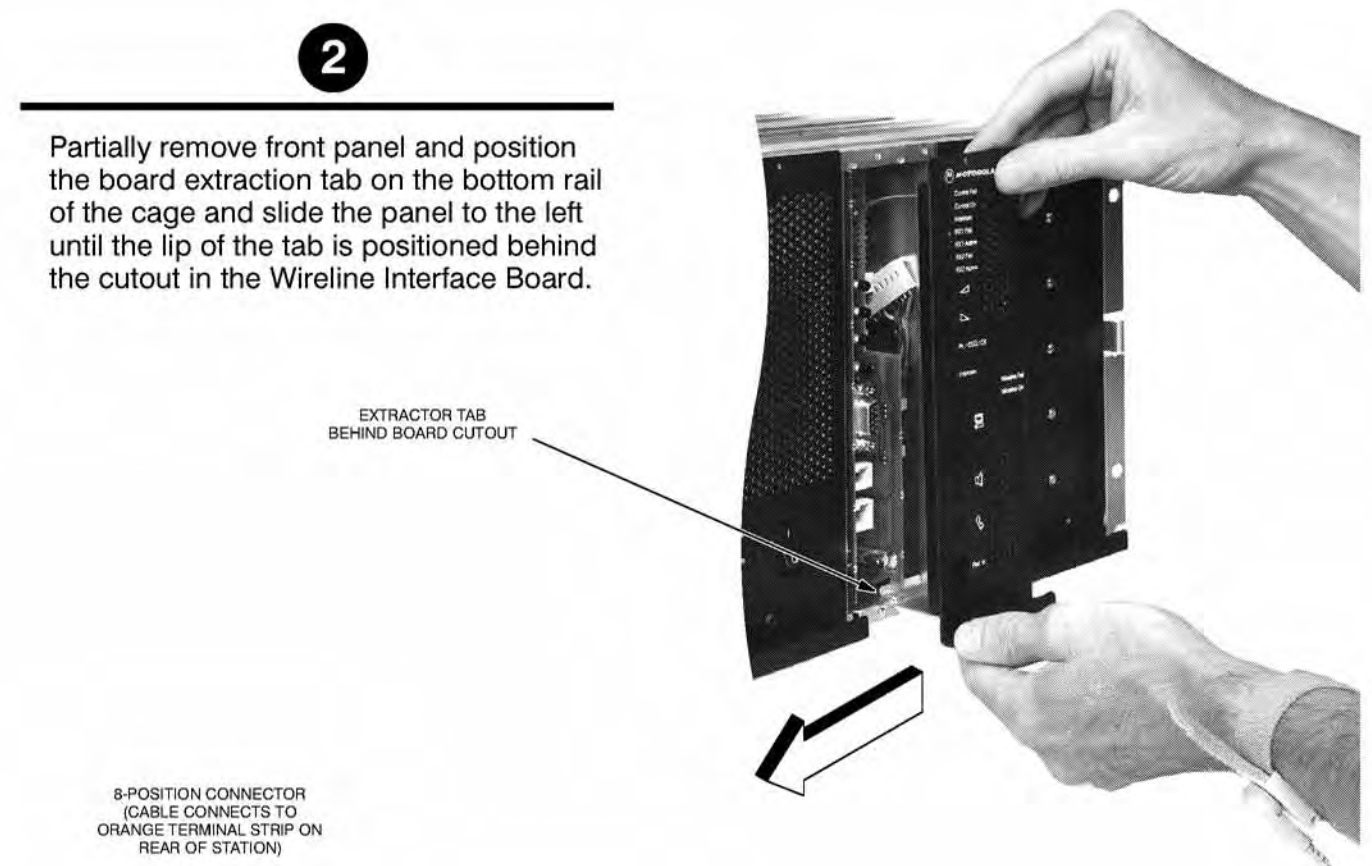
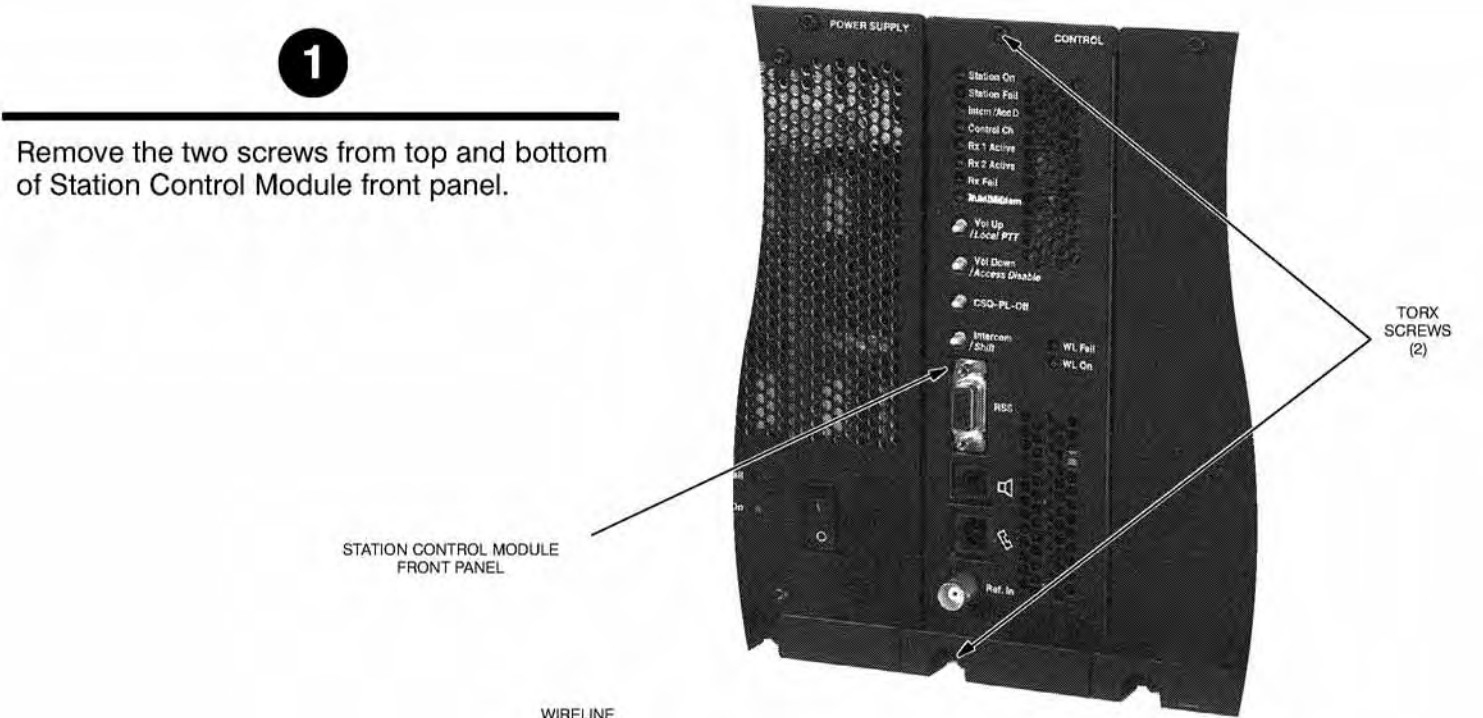

Figure 7. Removal Procedure for Wireline Interface Board (Quantar VHF Station Shown)

## Replacing Receiver Module and/or Preselector Assembly (VHF and UHF)

**Note:** On VHF and UHF models, the Receiver Module is comprised of a Preselector Assembly and a Receiver Board attached to a module housing. The Preselector Assembly and the Receiver Board are each considered to be a field replaceable unit (FRU). Replacement procedures are given for each FRU. If you choose to replace the entire module (including receiver board and preselector), you must perform the preselector tuning procedure.

### Replacement Procedure

- Step 1.** Turn off station power (refer to page 22).
- Step 2.** Using a Torx #15 driver, remove anti-vibration screws (if installed) from top and/or bottom of module front panel.
- Step 3.** Slide the module out to the first stop. Disconnect mini-UHF connector on rf cable (rf input to the module) connected to the preselector assembly.
- Step 4.** Remove faulty module from cage.
- Step 5.** If **Receiver Board** is being replaced:
  - Disconnect cable (mini-UHF connector) connected to Receiver Board.
  - Remove nine (9) Torx-head screws securing Receiver Board to module housing. Note location of foam insulating pad beneath VCO portion of Receiver Board.
  - Remove faulty board and replace with known good board. Be sure to position the foam insulating pad (noted in previous step) behind the VCO.
  - Secure board using Torx-head screws removed previously. Reconnect rf cable to mini-UHF connector on board.
- Step 6.** If **Preselector Assembly** is being replaced:
  - Disconnect cables (mini-UHF connectors) from assembly.
  - Remove faulty Preselector Assembly by removing two(2) Torx-head screws securing assembly to module housing.
  - Install known good assembly and secure using Torx-head screws removed previously. Reconnect rf cables to mini-UHF connectors.

(continued on next page)

---

## Replacing Receiver Module and/or Preselector Assembly (VHF and UHF) (Continued)

### **Replacement Procedure (Continued)**

- Step 7.** Install repaired Receiver Module by sliding module into cage (about 2 inches from full insertion). Connect the rf input cable to the mini-UHF connector on the Preselector Assembly.
- Step 8.** Slide the module in completely and firmly seat the module connector into the backplane. (**Do not** slam the module against the backplane or push any harder than necessary to seat the connectors.)
- Step 9.** Restore power to the station.

### **Post-Replacement Optimization Procedure**

- Step 1.** If you replaced the **Receiver Board** — Perform the *Squelch Adjust* and the *RSSI* alignment procedures located in the RSS User's Guide (68P81085E35).
- Step 2.** If you replaced the **Preselector Assembly** — Perform the preselector field tuning procedure beginning on page 38.

---

## Replacing Receiver Module (800 MHz and 900 MHz)

### **Replacement Procedure**

- Step 1.** Turn off station power (refer to page 22).
- Step 2.** Remove anti-vibration screws (if installed) from top and/or bottom of module front panel.
- Step 3.** Slide the module out to the first stop. Disconnect mini-UHF connector on rf cable (rf input to the module) connected to the preselector assembly.
- Step 4.** Remove faulty module from cage.
- Step 5.** Install replacement Receiver Module by sliding module into cage and firmly seating the module connector into the backplane. (**Do not** slam the module against the backplane or push any harder than necessary to seat the connectors.) Connect the rf cable to the mini-UHF connector at the top of the module.
- Step 6.** Restore power to the station.

### **Post-Replacement Optimization Procedure**

Perform the *Squelch Adjust* and the *RSSI* alignment procedures located in the RSS User's Guide (68P81085E35).

## Replacing ASTRO Modem Card

### Replacement Procedure

- Step 1.** Turn off station power (refer to page 22).
- Step 2.** Remove the Wireline Interface Board as described on page 32.
- Step 3.** Unplug faulty ASTRO Modem Card from Wireline Interface Board.
- Step 4.** Inspect the label on the EPROM (shown below). If the date is **8-16-93**, remove the EPROM and install it on the replacement board. For all other dates, the EPROM on the replacement board is compatible and need not be replaced.

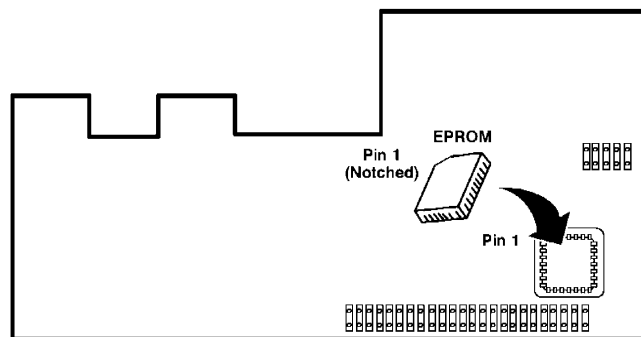

- Step 5.** Install replacement modem card.
- Step 6.** Install Wireline Interface Board as described on page 32.
- Step 7.** Restore power to the station.

### Post-Replacement Optimization Procedure

The ASTRO Modem Card requires no settings or adjustments. The card is configured by the Station Control Module on station power up.

---

## Replacing Backplane Board

### ***Replacement Procedure***

- Step 1.** Turn off station power (refer to page 22).
- Step 2.** Remove all modules/boards from the station cage as described on the previous pages. Make sure that all modules/boards are placed on properly grounded anti-static surface.
- Step 3.** Label all cables connected to the rear of the Backplane Board. Disconnect all cables from the backplane.
- Step 4.** Remove the eleven (11) Torx-head screws which secure the metal shield and backplane board to the cage.
- Step 5.** Remove the metal shield from the backplane, sliding the two guide pins located at each end at the bottom of the shield from the backplane board. Remove the backplane board.
- Step 6.** Install the replacement Backplane Board and metal shield using the 11 Torx-head screws removed previously, reconnect all cables, and reinstall all modules/boards.
- Step 7.** Restore power to the station.

### ***Post-Replacement Optimization Procedure***

Using the RSS, run a complete battery of diagnostics to exercise all boards and modules.

## 5 PRESELECTOR FIELD TUNING PROCEDURE

The VHF and UHF Receiver Modules are comprised of a circuit board and a preselector assembly, both secured in a slide-in module housing. The preselector assembly is a 3-pole (UHF) or a 5-pole (VHF) bandpass filter equipped with tuning slugs to adjust the passband corresponding to the operating frequency(s) of the station. The preselector assembly must be field tuned if replaced in the field or if the station operating frequency(s) are modified. The tuning procedure follows.

### Required Test Equipment

#### IMPORTANT

Tuning for best SINAD response **DOES NOT** result in optimum tuning of the preselector assembly. You must use this field tuning procedure to obtain optimum preselector performance.

The following test equipment is required to properly tune the preselector assembly:

- RF Signal Generator — Motorola R2600 Communications Analyzer, R2001 Communications Analyzer (see note), or HP8656A signal generator (or equivalent)
- Dip/Peak Monitor — HP435B Power Meter (or equivalent) with HP8484A sensitive power head, Boonton Model 92E with BNC input, or R2001/R2600 using the spectrum analyzer function
- Torque driver capable of delivering 12 in-lbs of torque and 10 mm deep well socket
- Tuning probe — Motorola Part No. 0180763D22, p/o TRN7799A tuning kit
- Flat-blade screwdriver

**Note:** The R2600 Communications Analyzer can both generate and measure simultaneously. The R2001 may be used for either the generator or the monitor function, but not both simultaneously. When using R2001 as the signal generator, rf signal **must** be taken from the Antenna port.

---

## VHF Tuning Procedure

### **Calculating Proper Alignment Frequency**

Use one of the following two methods to calculate the alignment frequency to be generated by the signal generator.

For stations with a **single receive frequency**, calculate the frequency of the alignment signal as follows:

Step 1. From the site documentation or the RSS, determine the station receive frequency.

Step 2. If the frequency is  $\leq 148$  MHz (Range 1), or  $\geq 156$  MHz (Range 2), subtract 250 kHz. Otherwise, note the actual frequency.

**Example:** If the station receive frequency is 134.575 MHz, subtract 250 kHz because the frequency is less than 143 MHz:  $134.575 \text{ MHz} - 250 \text{ kHz} = 134.325 \text{ MHz}$

Step 3. If the Receiver Module is **Range 1**, determine the alignment frequency as follows:

If the frequency (from Step 3) is  $< 134$  MHz, then alignment frequency = 133.75 MHz.

If frequency (from Step 3) is  $> 152$  MHz, then alignment frequency = 152 MHz.

Otherwise, use actual frequency from Step 2.

Step 4. If the Receiver Module is **Range 2**, determine the alignment frequency as follows:

If the frequency (from Step 3) is  $< 152$  MHz, then alignment frequency = 151.75 MHz.

If frequency (from Step 3) is  $> 152$  MHz, then alignment frequency = 172 MHz.

Otherwise, use actual frequency from Step 2.

For stations with **multiple receive frequencies**, calculate the frequency of the alignment signal as follows:

Step 1. From the documentaton or the RSS, note the receive frequency for each channel supported by the station.

Step 2. Calculate a midpoint frequency as follows:

$$F_{\text{mid}} = (F_{\text{highest}} + F_{\text{lowest}}) \div 2$$

Step 3. Using  $F_{\text{mid}}$  in place of the station receive frequency, perform Step 3 through Step 4 from above.



## VHF Tuning Procedure (Continued)

### Preparing Equipment

- Step 1.** Make sure Receiver Module (with Preselector Assembly) is installed in a functional station cage equipped with a Power Supply Module.
- Step 2.** Remove the two Torx-head screws from the Receiver Module front panel and remove the panel.
- Step 3.** Detune the preselector as follows.  
If the alignment frequency (calculated on the previous page) is greater than 148 MHz (Range 1) or 156 MHz (Range 2), turn the five tuning screws in (CW) until 1/8" protrudes past each of the tension nuts. If the alignment frequency is less than or equal to 148 MHz (Range 1) or 156 MHz (Range 2), back out (CCW) the five tuning screws until 3/4" protrudes past each of the tension nuts.
- Step 4.** Using the torque driver and deep well socket, tighten the five tension nuts on the adjustment screws to 6 in-lbs.
- Step 5.** Connect the test equipment as shown below:

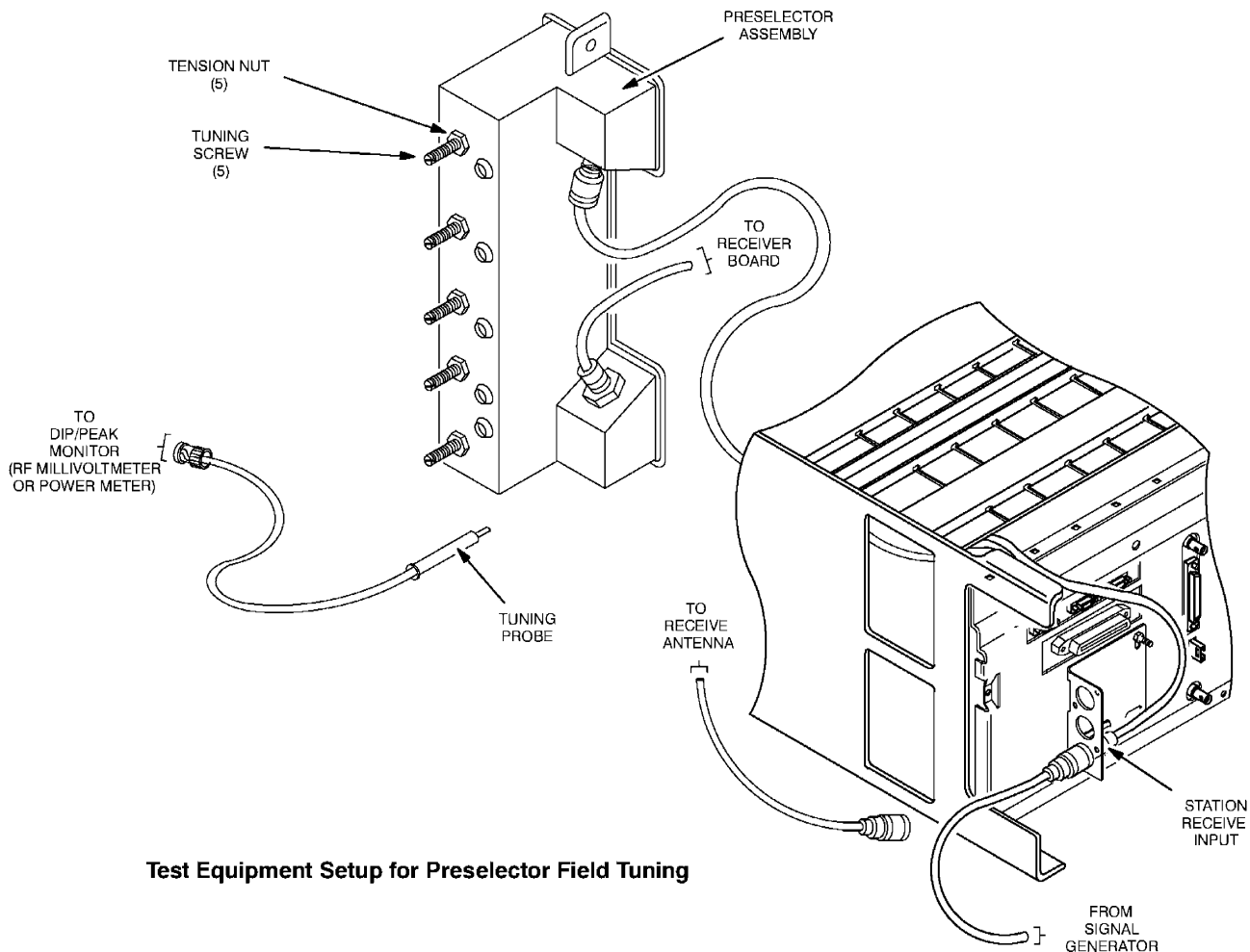

Test Equipment Setup for Preselector Field Tuning

## VHF Tuning Procedure (Continued)

### IMPORTANT

When tuning for peak or dip, turn the tuning screw  $\frac{1}{2}$  turn past the peak or dip to verify that you have obtained a true peak or dip. After ensuring you have found true peak or dip, turn the screw back to the location of the original peak or dip.

### Tuning Procedure

- Step 1.** Turn the station power supply ON (to provide the active  $50\Omega$  termination).
- Step 2.** Adjust the signal generator to the frequency calculated on page 42. Set the level to +5 dBm.
- Step 3.** Insert tuning probe into cavity H1 and adjust tuning screw 1 for a **PEAK**.
- Step 4.** Leave tuning probe in cavity H1 and adjust tuning screw 2 for a **DIP**.
- Step 5.** Insert tuning probe into cavity H2 and adjust tuning screw 3 for a **DIP**.
- Step 6.** Insert tuning probe into cavity H3 and adjust tuning screw 4 for a **DIP**.
- Step 7.** Insert tuning probe into cavity H4. Decrease output from signal generator to  $-5$  dBm.
- Step 8.** Adjust tuning screw 5 for a **DIP**. Then turn tuning screw 5  $\frac{1}{4}$  turn CCW. (Note that dip will not be as sharp for screw 5 as it was for screws 2 thru 4.)

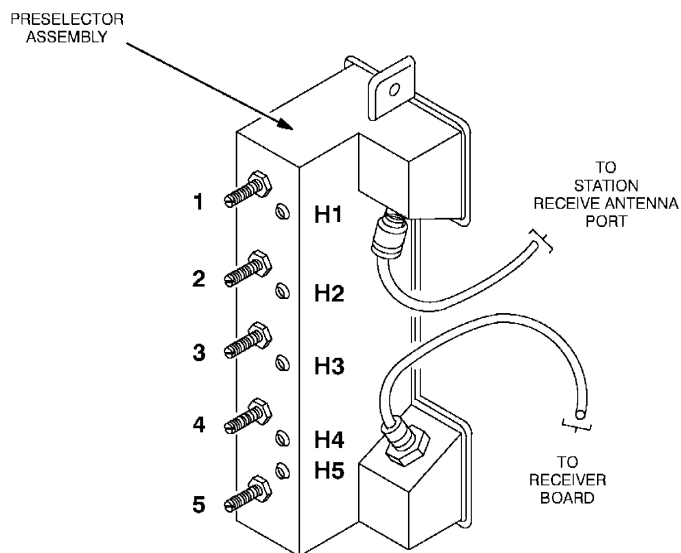

Location of Tuning Screws and Cavity Probe Holes

---

## UHF Tuning Procedure

### **Calculating Proper Alignment Frequency**

Use one of the following two methods to calculate the alignment frequency to be generated by the signal generator.

For stations with a **single receive frequency**, calculate the frequency of the alignment signal as follows:

- Step 1.** From the site documentation or the RSS, determine the station receive frequency. **Add 200 kHz.**
- Step 2.** If Receiver Module is **Range 0**, determine the alignment frequency as follows:  
If frequency (from Step 1) is > 431 MHz, then alignment frequency = 431 MHz.  
If frequency (from Step 1) is < 382 MHz, then alignment frequency = 382 MHz.  
Otherwise, use actual frequency from Step 1.
- Step 3.** If Receiver Module is **Range 1**, determine the alignment frequency as follows:  
If frequency (from Step 1) is > 431 MHz, then alignment frequency = 431 MHz.  
If frequency (from Step 1) is < 405 MHz, then alignment frequency = 405 MHz.  
Otherwise, use actual frequency from Step 1.
- Step 4.** If Receiver Module is **Range 2**, determine the alignment frequency as follows:  
If frequency (from Step 1) is > 468 MHz, then alignment frequency = 468 MHz.  
If frequency (from Step 1) is < 440 MHz, then alignment frequency = 440 MHz.  
Otherwise, use actual frequency from Step 1.
- Step 5.** If Receiver Module is **Range 3 or 4**, determine the alignment frequency as follows:  
If frequency (from Step 1) is > 518 MHz, then alignment frequency = 518 MHz.  
If frequency (from Step 1) is < 472 MHz, then alignment frequency = 472 MHz.  
Otherwise, use actual frequency from Step 1.

— continued on next page —

---

## UHF Tuning Procedure (continued)

For stations with **multiple receive frequencies**, calculate the frequency of the alignment signal as follows:

- Step 1.** From the site documentation or the RSS, note the receive frequency for each channel supported by the station.
- Step 2.** Calculate a midpoint frequency as follows:  
$$F_{\text{mid}} = (F_{\text{highest}} + F_{\text{lowest}}) \div 2$$
- Step 3.** Using  $F_{\text{mid}}$  in place of the station receive frequency, perform Step 1 thru Step 5 from above.

## UHF Tuning Procedure (Continued)

### Preparing Equipment

- Step 1.** Make sure Receiver Module (with Preselector Assembly) is installed in a functional station cage equipped with a Power Supply Module.
- Step 2.** Remove the two Torx-head screws from the Receiver Module front panel and remove the panel.
- Step 3.** Using the torque driver and deep well socket, loosen the three tension nuts on the adjustment screws.
- Step 4.** Detune the preselector as follows.  
Turn tuning screws 3 and 4 clockwise until they bottom out. Be careful not to apply more than 3 in-lbs of torque to prevent warping preselector cover and housing.
- Step 5.** Connect the test equipment as shown below:

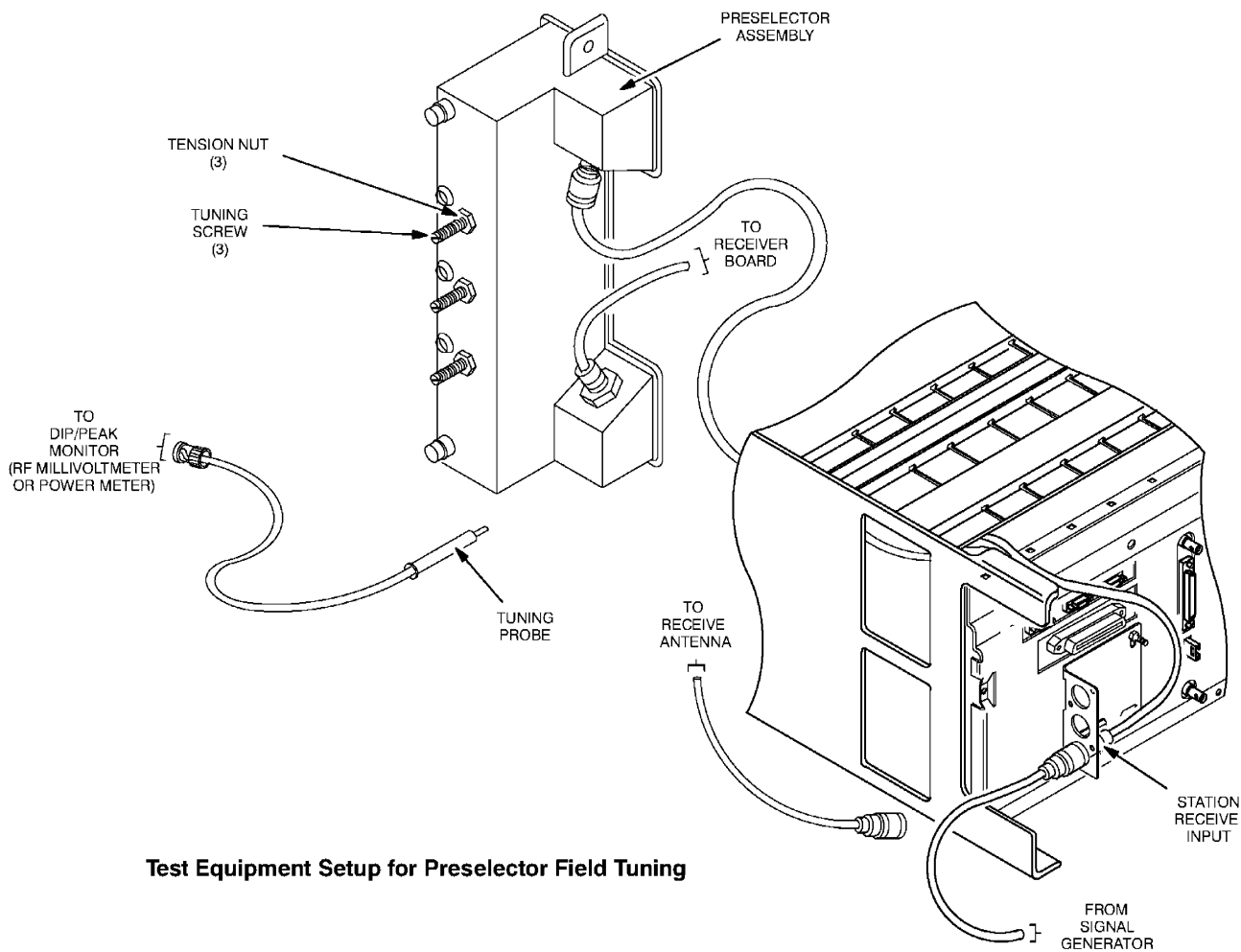

**Test Equipment Setup for Preselector Field Tuning**

## Tuning Procedure (Continued)

### IMPORTANT

When tuning for peak or dip, turn the tuning screw  $\frac{1}{2}$  turn past the peak or dip to verify that you have obtained a true peak or dip. After ensuring you have found true peak or dip, turn the screw back to the location of the original peak or dip.

### Tuning Procedure

- Step 1.** Turn the station power supply ON (to provide the active  $50\Omega$  termination).
- Step 2.** Adjust the signal generator to the frequency calculated on page 42. Set the level to +5 dBm.
- Step 3.** Insert tuning probe into cavity U2 and adjust tuning screw 2 for a **PEAK**.
- Step 4.** Tighten tension nut on tuning screw 2 to at least 12 in-lb and fine tune tuning screw 2 for a **PEAK**.
- Step 5.** Keep tuning probe in cavity U2 and adjust tuning screw 3 for a **DIP**.
- Step 6.** Tighten tension nut on tuning screw 3 to at least 12 in-lb and fine tune tuning screw 2 for a **DIP**.
- Step 7.** Insert tuning probe into cavity U3. Decrease output from signal generator to -5 dBm.
- Step 8.** Adjust tuning screw 4 for a **DIP**.
- Step 9.** Tighten tension nut on tuning screw 4 to at least 12 in-lb and fine tune tuning screw 4 for a **DIP**.

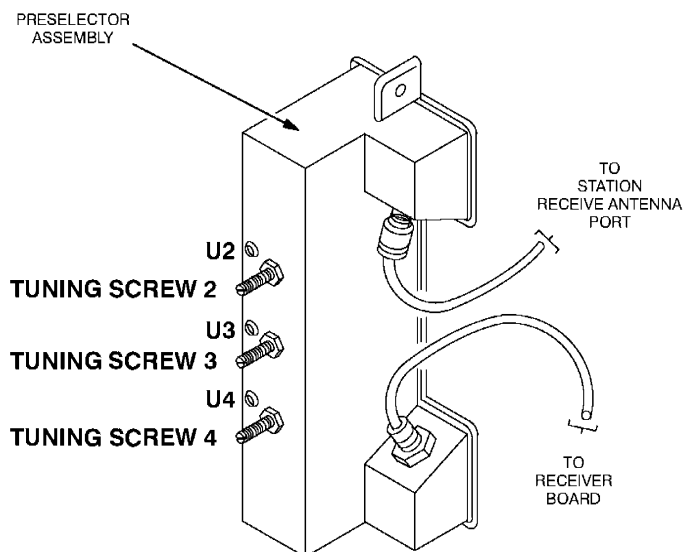

Location of Tuning Screws and Cavity Probe Holes



# RECEIVER MODULE

## INCLUDES MODELS:

**TRD6361A-F Receiver Board(132–154 MHz)**  
**TFD6511A Preselector Filter (132–154 MHz)**  
**TRD6362A-F Receiver Board (150–174 MHz)**  
**TFD6512A Preselector Filter (150–174 MHz)**

## 1 DESCRIPTION

The *Quantar/Quantro* VHF High Band Receiver Modules are described in this section. A general description, identification of controls, indicators, and inputs/outputs, a functional block diagram, and functional theory of operation are provided. The information provided is sufficient to give service personnel a functional understanding of the module, allowing maintenance and troubleshooting to the module level. (Refer also to the Maintenance and Troubleshooting section of this manual for detailed troubleshooting procedures for all modules in the station.)

### General Description

The Receiver Module provides the receiver functions for the *Quantar* VHF station. Each receiver module is comprised of a Preselector Filter Assembly and a Receiver Board, all contained within a slide-in module housing. The receiver module performs highly selective bandpass filtering and dual down conversion of the station receive rf signal. A custom receiver IC then performs an analog to digital conversion of the received signal and outputs a differential data signal to the Station Control Module.

The Models TFD6511/TFD6512 Preselector Filter Assemblies and the TRD6361/TRD6362 Receiver Boards differ only in the range of operation. Models TFD6511/TRD6361 operate in VHF Range 1 (132–154MHz); Models TFD6512/TRD6362 operate in VHF Range 2 (150–174MHz). Unless otherwise noted, the information provided in this section applies to all models.

### Overview of Circuitry

The receiver module contains the following circuitry:

- Frequency Synthesizer Circuitry— consisting of a phase-locked loop and VCO, generates the 1st LO injection signal
- Preselector Filter Assembly — provides 5-pole bandpass filtering of the station receive rf input
- Receiver Front End Circuitry — performs filtering, amplification, and the 1st down conversion of the receive rf signal
- Custom Receiver IC Circuitry — consists of a custom IC which performs the 2nd down conversion, filtering, amplification, and analog to digital conversion of the receive signal
- Address Decode & A/D Converter Circuitry — performs address decoding to provide board and chip select signals; also converts analog status signals to digital format for transfer to Station Control Module
- Local Power Supply Regulation — accepts +14.2V dc input and outputs +10V and +5V dc operating voltages

## 2 CONTROLS, INDICATORS, AND INPUTS/OUTPUTS

Figure 1 shows the receiver module controls, indicators, and all input and output external connections.

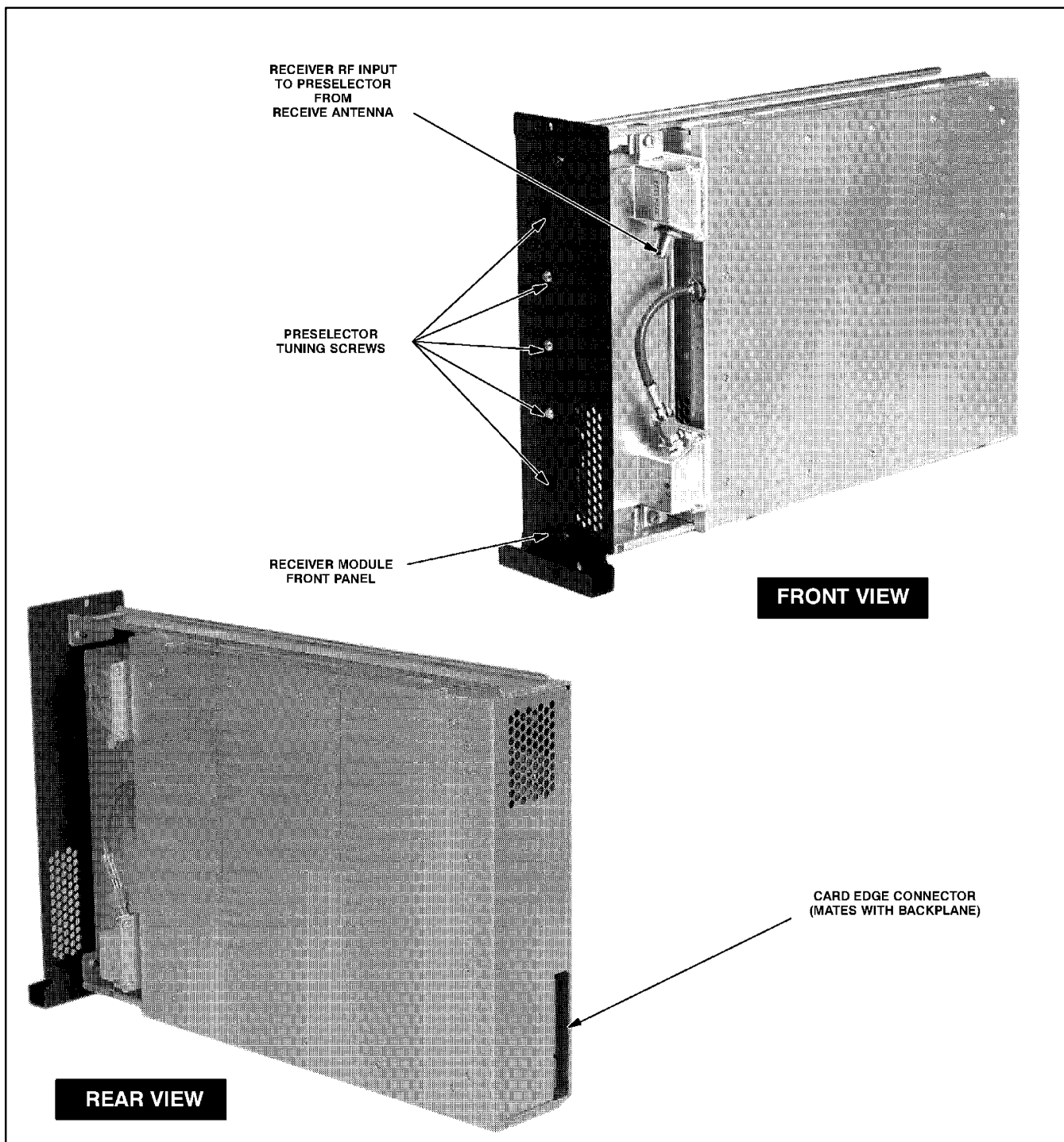

Figure 1. Quantar/Quantro VHF Receiver Module Controls, Indicators, and Inputs/Outputs



# 3

## FUNCTIONAL THEORY OF OPERATION

The following theory of operation describes the operation of the receiver circuitry at a functional level. The information is presented to give the service technician a basic understanding of the functions performed by the module in order to facilitate maintenance and troubleshooting to the module level. Refer to Figure 2 for a block diagram of the receiver module.

### Synthesizer and VCO Circuitry

#### **Introduction**

The synthesizer and VCO circuitry generate the 1st LO injection signal for the 1st mixer in the receiver front end circuitry. Functional operation of these circuits is as follows.

#### **Phase-Locked Loop**

The phase-locked loop (PLL) IC receives frequency selection data from the Station Control Module microprocessor. Once programmed, the PLL IC compares a 2.1 MHz reference signal (from the Station Control Module) with a feedback sample of the VCO output. Depending on whether the feedback signal is higher or lower in frequency than the 2.1 MHz reference, correction pulses are generated. (The width of these correction pulses is dependent on the amount of difference between the 2.1 MHz reference and the VCO feedback.)

The up/down pulses from the PLL IC are fed to a charge pump which outputs a dc voltage proportional to the pulse widths. This dc voltage is then low-pass filtered and fed to the VCO as the *CONTROL VOLTAGE*. (Note that if a frequency change is requested by the microprocessor, the low-pass loop filter is momentarily bypassed to accelerate the frequency change.)

#### **VCO**

The dc control voltage from the synthesizer is fed to dual VCOs which generate the 1st LO injection signal. Within each band (Range 1 and Range 2), one VCO generates signals in the upper half of the band, while the other VCO generates signals in the lower half of the band. Only one VCO is active at a time. Selection of the active VCO is provided by a *BANDSHIFT* signal from the PLL IC.

The active VCO responds to the dc control voltage and generates the appropriate rf signal. This signal is fed through a buffer amplifier and impedance matching and output to the 1st LO injection amplifier in the receiver front end circuitry. A sample of the injection signal is returned to the PLL IC (via a feedback buffer) to serve as a VCO feedback signal.

---

## Preselector Filter Assembly

The preselector filter assembly provides 5 poles of bandpass filtering for the station receive rf input signal. The filter assembly is mounted to the front of the receiver module housing and provides mini-UHF connectors for input from the receive antenna and output to the receiver board. Tuning screws are provided for filter tuning. (Refer to the *Troubleshooting* section in this manual for instructions on tuning the preselector assembly.)

---

## Receiver Front End Circuitry

The receive rf input is fed from the antenna through the 5-pole preselector assembly to the receiver board. The signal is low-pass filtered, amplified, image filtered, and fed to one input of the 1st mixer. The signal is mixed with the 1st LO injection signal (generated by the synthesizer/VCO circuitry) to produce a 21.45 MHz 1st i-f signal.

The 1st i-f signal is 2-pole bandpass filtered and fed to an amplifier. The amplifier gain (high or low) is determined by an AGC switch circuit that is controlled by an AGC select signal from the Station Control Board. The amplified 1st i-f signal is then 4-pole bandpass filtered and fed to the rf input of the custom receiver IC.

---

## Custom Receiver IC Circuitry

The custom receiver IC provides additional amplification, filtering, a second down conversion, and finally analog to digital conversion of the 2nd i-f signal. The digital receive signal is then output via differential driver circuitry to the Station Control Board. This data signal contains the necessary I and Q quadrature information, AGC information, and other data transfer information required by the Station Control Board to process the receive signal. (Note that the recovered audio signal is in digital format throughout the station circuitry, resulting in a more noise-free, linear receiver. Analog audio is present only in the external speaker driver circuitry on the Station Control Board and on the Wireline Interface Board at the phone line connections to and from the station.)

The remainder of the custom receiver IC circuitry consists of timing and tank circuits to support the internal oscillator, 2nd LO synthesizer circuitry, and 2nd i-f circuitry.

A serial bus allows data communications between the custom receiver IC and the DSP ASIC located on the Station Control Board. This bus allows the DSP ASIC to control various current and gain settings, establish the data bus clock rate, program the 2nd LO, and perform other control functions.

---

## Address Decode and A/D Converter Circuitry

### **Address Decode Circuitry**

The address decode circuitry allows the Station Control Board to use the address bus to select a specific device on a specific station board for control or data communications purposes (via the SPI bus). If the board select circuitry decodes address lines A2 thru A5 as the receiver module address, it enables the chip select circuitry. The chip select circuitry then decodes address lines A0 and A1 and generates chip select signals for the PLL and A/D converter and the *SYNTH ADAPT* signal to control the loop filter bypass switch in the synthesizer circuitry.

### **A/D Converter Circuitry**

Analog signals from various strategic operating points throughout the receiver board are fed to the A/D converter, which converts them to a digital signal and, upon request by the Station Control Board, outputs the signal to the Station Control Board via the SPI bus.

---

## Voltage Regulator Circuitry

The voltage regulator circuitry consists of +10V and two +5V regulators. The +10V regulator accepts a +14.2V dc input and generates a +10V dc operating voltage for the receiver board circuitry.

The +10V regulator output also feeds two +5V regulators which output Custom Analog +5V and Custom Digital +5V dc operating voltages to supply the custom receiver IC. In addition, a +5V dc operating voltage is input at the backplane (from the station power supply) to supply Digital +5V to the remainder of the receiver board circuitry.

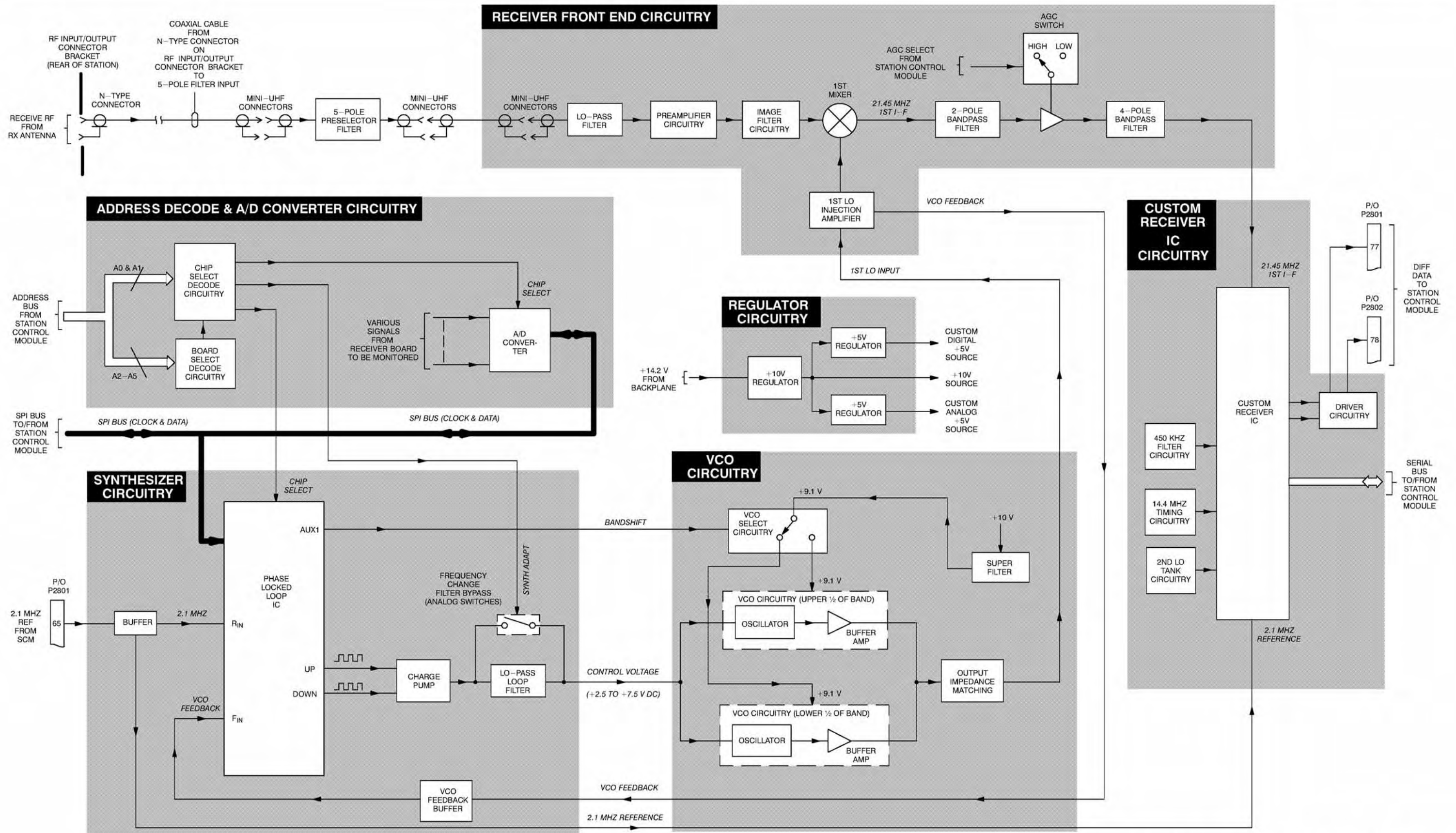

Figure 2. VHF Ranges 1 and 2 Receiver Module Functional Block Diagram

**INCLUDES MODELS:**

CRX4022A Receiver Board/CRX4001A Preselector (380–433 MHz)  
TRE6281A–E Receiver Board/TLE5991A Preselector (403–433 MHz)  
TRE6282A–E Receiver Board/TLE5992A Preselector (438–470 MHz)  
TRE6283A–E Receiver Board/TLE5993A Preselector (470–494 MHz)  
TRE6284A–E Receiver Board/TLE5993A Preselector (494–520 MHz)

## 1 DESCRIPTION

The *Quantar/Quantro* UHF Receiver Modules (ranges 0 thru 4) are described in this section. A general description, identification of controls, indicators, and inputs/outputs, a functional block diagram, and functional theory of operation are provided. The information provided is sufficient to give service personnel a functional understanding of the module, allowing maintenance and troubleshooting to the module level. (Refer also to the Maintenance and Troubleshooting section of this manual for detailed troubleshooting procedures for all equipment modules.)

### General Description

The Receiver Module provides the receiver functions for the *Quantar/Quantro* communications equipment. Each receiver module is comprised of a Preselector Filter Assembly and a Receiver Board, all contained within a slide-in module housing. The receiver module performs highly selective bandpass filtering and dual down conversion of the receive rf signal. A custom receiver IC then performs an analog to digital conversion of the received signal and outputs a differential data signal to the Station Control Module.

The preselector and receiver board models differ only in the range of operation. Unless otherwise noted, the information provided in this section applies to all models.

### Overview of Circuitry

The receiver module contains the following circuitry:

- Frequency Synthesizer Circuitry— consisting of a phase-locked loop and VCO, generates the 1st LO injection signal
- Preselector Filter Assembly — provides 3–pole bandpass filtering of the receive rf input
- Receiver Front End Circuitry — performs filtering, amplification, and the 1st down conversion of the receive rf signal
- Custom Receiver IC Circuitry — consists of a custom IC which performs the 2nd down conversion, filtering, amplification, and analog to digital conversion of the receive signal
- Address Decode & A/D Converter Circuitry — performs address decoding to provide board and chip select signals; also converts analog status signals to digital format for transfer to Station Control Module
- Local Power Supply Regulation — accepts +14.2 V dc input and outputs +10V and +5V dc operating voltages

## 2 CONTROLS, INDICATORS, AND INPUTS/OUTPUTS

Figure 1 shows the receiver module controls, indicators, and all input and output external connections.

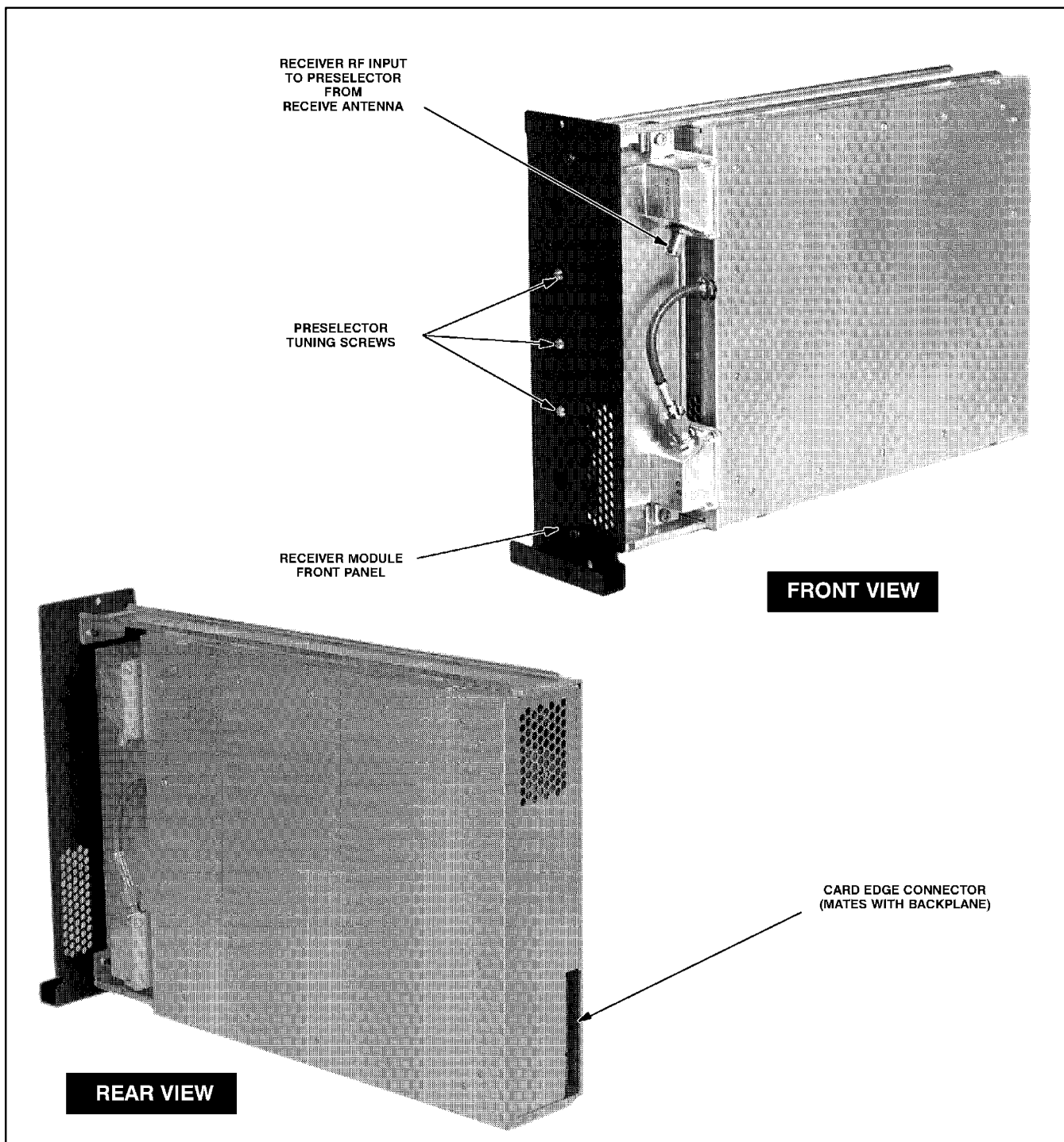

**Figure 1.** UHF Receiver Module Controls, Indicators, and Inputs/Outputs

# 3

## FUNCTIONAL THEORY OF OPERATION

The following theory of operation describes the operation of the receiver circuitry at a functional level. The information is presented to give the service technician a basic understanding of the functions performed by the module in order to facilitate maintenance and troubleshooting to the module level. Refer to Figure 2 for a block diagram of the receiver module.

### Synthesizer and VCO Circuitry

#### **Introduction**

The synthesizer and VCO circuitry generate the 1st LO injection signal for the 1st mixer in the receiver front end circuitry. Functional operation of these circuits is as follows.

#### **Phase-Locked Loop**

The phase-locked loop (PLL) IC receives frequency selection data from the Station Control Module microprocessor. Once programmed, the PLL IC compares a 2.1 MHz reference signal (from the Station Control Module) with a feedback sample of the VCO output. Depending on whether the feedback signal is higher or lower in frequency than the 2.1 MHz reference, correction pulses are generated. (The width of these correction pulses is dependent on the amount of difference between the 2.1 MHz reference and the VCO feedback.)

The up/down pulses from the PLL IC are fed to a charge pump which outputs a dc voltage proportional to the pulse widths. This dc voltage is then low-pass filtered and fed to the VCO as the *CONTROL VOLTAGE*. (Note that if a frequency change is requested by the microprocessor, the low-pass loop filter is momentarily bypassed to accelerate the frequency change.)

#### **VCO**

The dc control voltage from the synthesizer is fed to dual VCOs which generate the 1st LO injection signal. Within each band (Ranges 0 thru 4), one VCO generates signals in the upper half of the band, while the other VCO generates signals in the lower half of the band. Only one VCO is active at a time. Selection of the active VCO is provided by a *BANDSHIFT* signal from the PLL IC.

The active VCO responds to the dc control voltage and generates the appropriate rf signal. This signal is fed through a buffer amplifier and impedance matching and output to the 1st LO injection amplifier in the receiver front end circuitry. A sample of the injection signal is returned to the PLL IC (via a feedback buffer) to serve as a VCO feedback signal.

---

## Preselector Filter Assembly

The preselector filter assembly provides 3 poles of bandpass filtering for the receive rf input signal. The filter assembly is mounted to the front of the receiver module housing and provides mini-UHF connectors for input from the receive antenna and output to the receiver board. Tuning screws are provided for filter tuning. (Refer to the *Troubleshooting* section in this manual for instructions on tuning the preselector assembly.)

---

## Receiver Front End Circuitry

The receive rf input is fed from the antenna through the 3-pole preselector assembly to the receiver board. The signal is low-pass filtered, amplified, image filtered, and fed to one input of the 1st mixer. The signal is mixed with the 1st LO injection signal (generated by the synthesizer/VCO circuitry) to produce a 73.35 MHz 1st i-f signal.

The 1st i-f signal is 2-pole bandpass filtered and fed to an amplifier. The amplifier gain (high or low) is determined by an AGC switch circuit that is controlled by an AGC select signal from the Station Control Module. The amplified 1st i-f signal is then 4-pole bandpass filtered and fed to the rf input of the custom receiver IC.

---

## Custom Receiver IC Circuitry

The custom receiver IC provides additional amplification, filtering, a second down conversion, and finally analog to digital conversion of the 2nd i-f signal. The digital receive signal is then output via differential driver circuitry to the Station Control Board. This data signal contains the necessary I and Q quadrature information, AGC information, and other data transfer information required by the Station Control Module to process the receive signal. (Note that the recovered audio signal is in digital format throughout the equipment circuitry, resulting in a more noise-free, linear receiver. Analog audio is present only in the external speaker driver circuitry on the Station Control Board and on the Wire-line Interface Board at the phone line connections to and from the equipment.)

The remainder of the custom receiver IC circuitry consists of 2nd LO VCO circuitry and timing and tank circuits to support internal circuitry.

A serial bus allows data communications between the custom receiver IC and the DSP ASIC located on the Station Control Board. This bus allows the DSP ASIC to control various current and gain settings, establish the data bus clock rate, program the 2nd LO, and perform other control functions.



---

## Address Decode and A/D Converter Circuitry

### **Address Decode Circuitry**

The address decode circuitry allows the Station Control Board to use the address bus to select a specific device on a specific station board for control or data communications purposes (via the SPI bus). If the board select circuitry decodes address lines A2 thru A5 as the receiver module address, it enables the chip select circuitry. The chip select circuitry then decodes address lines A0 and A1 and generates chip select signals for the PLL and A/D converter and the *SYNTH ADAPT* signal to control the loop filter bypass switch in the synthesizer circuitry.

### **A/D Converter Circuitry**

Analog signals from various strategic operating points throughout the receiver board are fed to the A/D converter, which converts them to a digital signal and, upon request by the Station Control Module, outputs the signal to the Station Control Module via the SPI bus.

---

## Voltage Regulator Circuitry

The voltage regulator circuitry consists of +10V and three +5V regulators. The +10V regulator accepts a +14.2V dc input and generates a +10V dc operating voltage for the receiver board circuitry.

The +10V regulator output also feeds three +5V regulators. Two of the regulators provide Custom Analog +5V and Custom Digital +5V dc operating voltages to supply the custom receiver IC. The third regulator provides Synth +5V to supply the synthesizer circuitry.

In addition, a +5V dc operating voltage is input at the backplane (from the station power supply) to supply Digital +5V to the remainder of the receiver board circuitry.

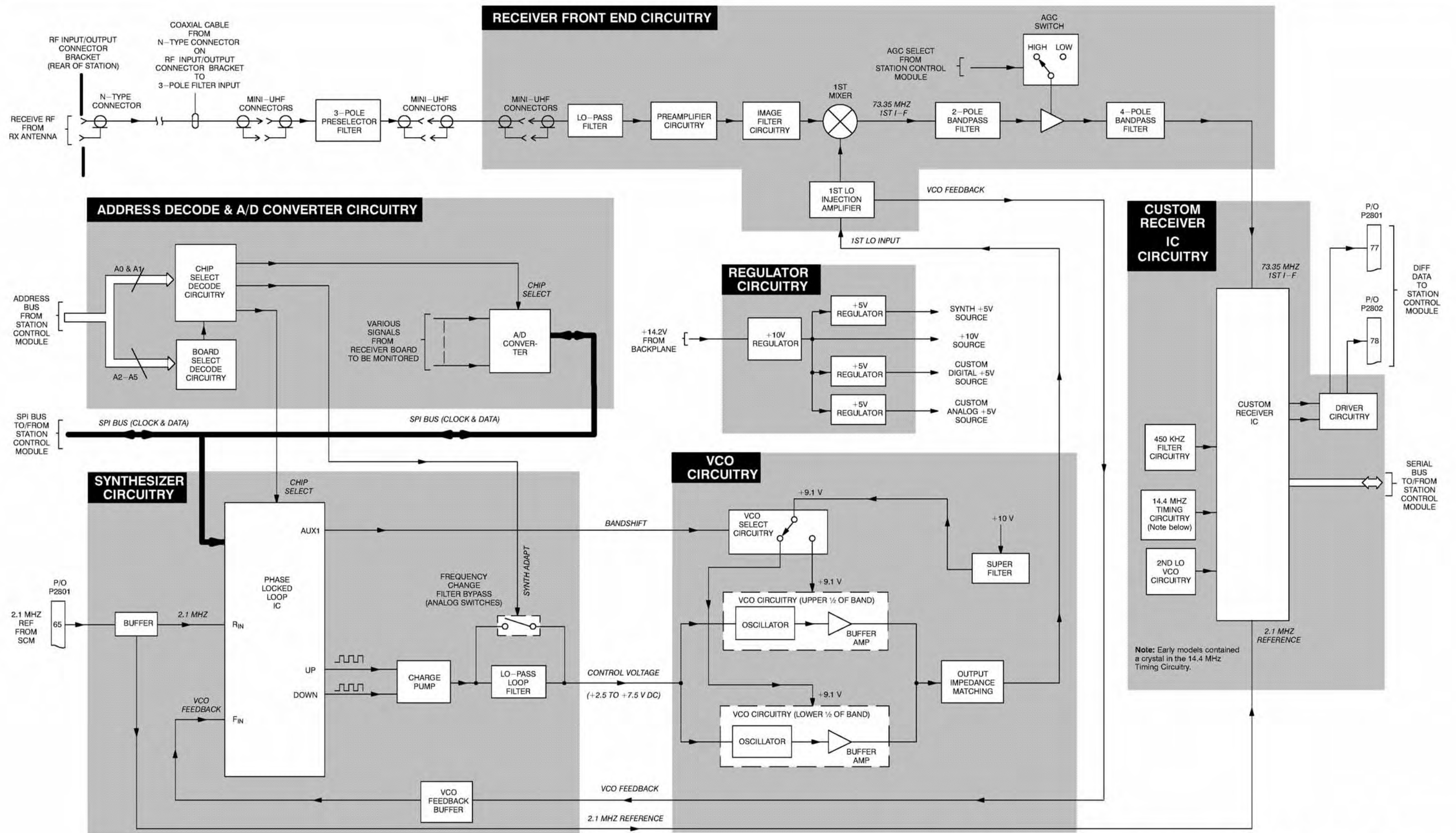

Figure 2. Quantar/Quantro UHF (Ranges 0 thru 4) Receiver Module Functional Block Diagram

## 1 DESCRIPTION

The *Quantro/Quantar* 800 MHz Receiver Module is described in this section. A general description, identification of controls, indicators, and inputs/outputs, a functional block diagram, and functional theory of operation are provided. The information provided is sufficient to give service personnel a functional understanding of the module, allowing maintenance and troubleshooting to the module level. (Refer also to the Maintenance and Troubleshooting section of this manual for detailed troubleshooting procedures for all modules in the station.)

### General Description

The Receiver Module provides the receiver functions for the *Quantro/Quantar* 800 MHz station. The receiver module is comprised of a Receiver Board and a ceramic preselector (mounted on board), all contained within a slide-in module housing. The receiver module performs highly selective bandpass filtering and dual down conversion of the station receive rf signal. A custom receiver IC then performs an analog to digital conversion of the received signal and outputs a differential data signal to the Station Control Module.

### Overview of Circuitry

The receiver module contains the following circuitry:

- Frequency Synthesizer Circuitry— consisting of a phase-locked loop and VCO, generates the 1st LO injection signal
- Ceramic Preselector Filter — provides 7-pole bandpass filtering of the station receive rf input
- Receiver Front End Circuitry — performs filtering, amplification, and the 1st down conversion of the receive rf signal
- Custom Receiver IC Circuitry — consists of a custom IC which performs the 2nd down conversion, filtering, amplification, and analog to digital conversion of the receive signal
- Address Decode & A/D Converter Circuitry — performs address decoding to provide board and chip select signals; also converts analog status signals to digital format for transfer to Station Control Module
- Local Power Supply Regulation — accepts +14.2V dc input and outputs +10V and +5V dc operating voltages

## 2 CONTROLS, INDICATORS, AND INPUTS/OUTPUTS

Figure 1 shows the receiver module controls, indicators, and all input and output external connections.

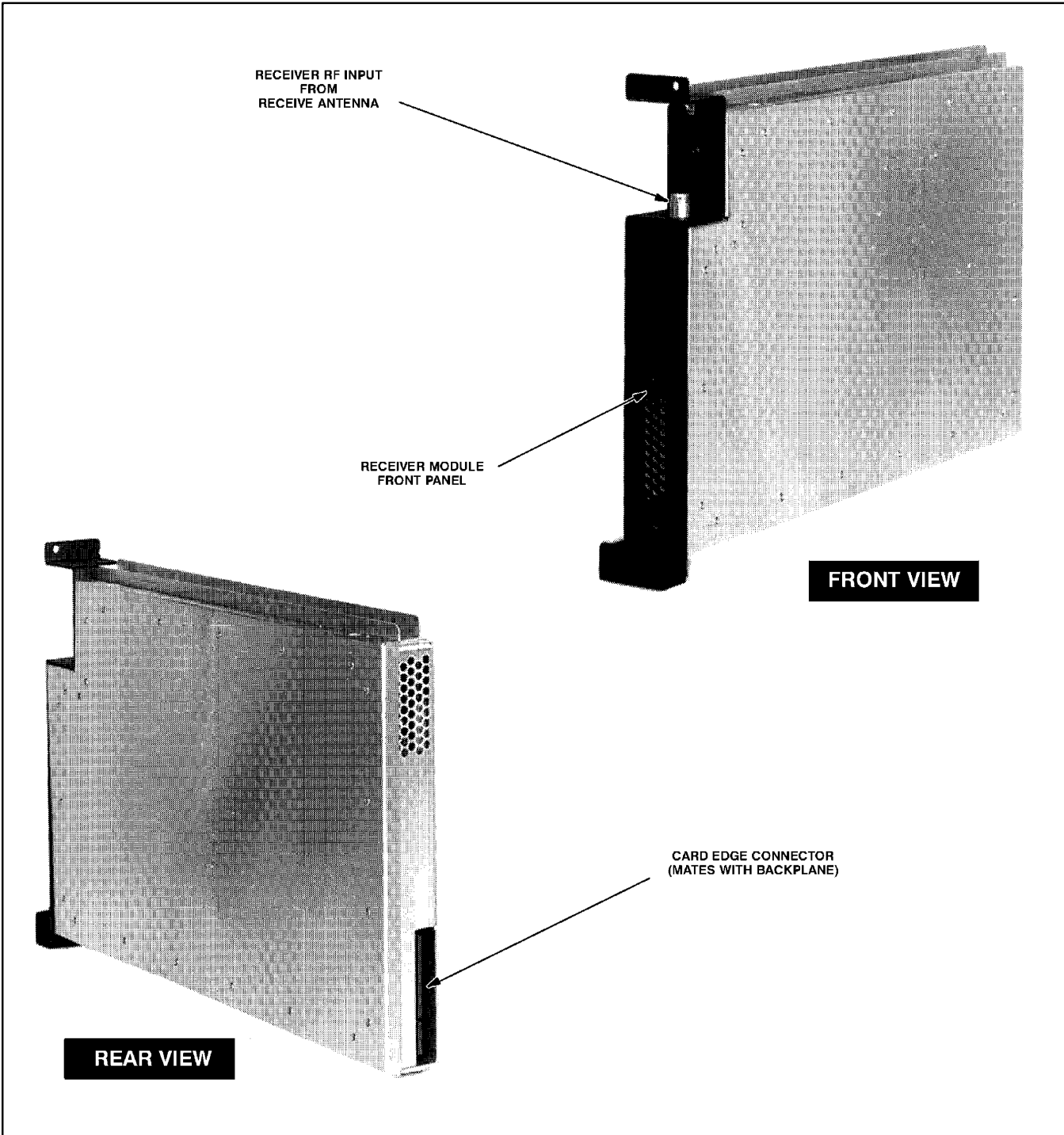

**Figure 1.** Quantro/Quantar 800 MHz Receiver Module Controls, Indicators, and Inputs/Outputs

# 3

## FUNCTIONAL THEORY OF OPERATION

The following theory of operation describes the operation of the receiver circuitry at a functional level. The information is presented to give the service technician a basic understanding of the functions performed by the module in order to facilitate maintenance and troubleshooting to the module level. Refer to Figure 2 for a block diagram of the receiver module.

### Synthesizer and VCO Circuitry

#### **Introduction**

The synthesizer and VCO circuitry generate the 1st LO injection signal for the 1st mixer in the receiver front end circuitry. Functional operation of these circuits is as follows.

#### **Phase-Locked Loop**

The phase-locked loop (PLL) IC receives frequency selection data from the Station Control Module microprocessor. Once programmed, the PLL IC compares a 2.1 MHz reference signal (from the Station Control Module) with a feedback sample of the VCO output. Depending on whether the feedback signal is higher or lower in frequency than the 2.1 MHz reference, correction pulses are generated. (The width of these correction pulses is dependent on the amount of difference between the 2.1 MHz reference and the VCO feedback.)

The up/down pulses from the PLL IC are fed to a charge pump which outputs a dc voltage proportional to the pulse widths. This dc voltage is then low-pass filtered and fed to the VCO as the *CONTROL VOLTAGE*. (Note that if a frequency change is requested by the microprocessor, the low-pass loop filter is momentarily bypassed to accelerate the frequency change.)

#### **VCO**

The dc control voltage from the synthesizer is fed to a VCO which generates the 1st LO injection signal. The VCO responds to the dc control voltage and generates the appropriate rf signal. This signal is fed through a buffer amplifier and impedance matching and output to the 1st LO injection amplifier in the receiver front end circuitry. A sample of the injection signal is returned to the PLL IC (via a feedback buffer) to serve as a VCO feedback signal.

---

## Receiver Front End Circuitry

The receive rf input is fed from the antenna through a low-pass filter to a 7-pole ceramic preselector filter which provides highly selective bandpass filtering. The output of the preselector filter is then amplified, image filtered, and fed to one input of the 1st mixer. The signal is mixed with the 1st LO injection signal (generated by the synthesizer/VCO circuitry) to produce a 73.35 MHz 1st i-f signal.

The 1st i-f signal is 2-pole bandpass filtered and fed to an amplifier. The amplifier gain (high or low) is determined by an AGC switch circuit that is controlled by an AGC select signal from the Station Control Module. The amplified 1st i-f signal is then 4-pole bandpass filtered and fed to the rf input of the custom receiver IC.

---

## Custom Receiver IC Circuitry

The custom receiver IC provides additional amplification, filtering, a second down conversion, and finally analog to digital conversion of the 2nd i-f signal. The digital receive signal is then sent via differential driver circuitry to the Station Control Board. This data signal contains the necessary I and Q quadrature information, AGC information, and other data transfer information required by the Station Control Module to process the receive signal. (Note that the recovered audio signal is in digital format throughout the station circuitry, resulting in a more noise-free, linear receiver. Analog audio is present only in the external speaker driver circuitry on the Station Control Board and on the Wireline Interface Board at the phone line connections to and from the station.)

The remainder of the custom receiver IC circuitry consists of timing and tank circuits to support the internal oscillator, 2nd LO synthesizer circuitry, and 2nd i-f circuitry.

A serial bus allows data communications between the custom receiver IC and the DSP ASIC located on the Station Control Board. This bus allows the DSP ASIC to control various current and gain settings, establish the data bus clock rate, program the 2nd LO, and perform other control functions.

---

## Address Decode and A/D Converter Circuitry

### **Address Decode Circuitry**

The address decode circuitry allows the Station Control Board to use the address bus to select a specific device on a specific station board for control or data communications purposes (via the SPI bus). If the board select circuitry decodes address lines A2 thru A5 as the receiver module address, it enables the chip select circuitry. The chip select circuitry then decodes address lines A0 and A1 and generates chip select signals for the PLL and A/D converter and the *SYNTH ADAPT* signal to control the loop filter bypass switch in the synthesizer circuitry.

### **A/D Converter Circuitry**

Analog signals from various strategic operating points throughout the receiver board are fed to the A/D converter, which converts them to a digital signal and, upon request by the Station Control Module, outputs the signal to the Station Control Module via the SPI bus.

---

## Voltage Regulator Circuitry

The voltage regulator circuitry consists of +10V and two +5V regulators. The +10V regulator accepts a +14.2V dc input and generates a +10V dc operating voltage for the receiver board circuitry.

The +10V regulator output also feeds two +5V regulators which output Custom Analog +5V and Custom Digital +5V dc operating voltages to supply the custom receiver IC and Synthesizer IC. In addition, a +5V dc operating voltage is input at the backplane (from the station power supply) to supply Digital +5V to the remainder of the receiver board circuitry.

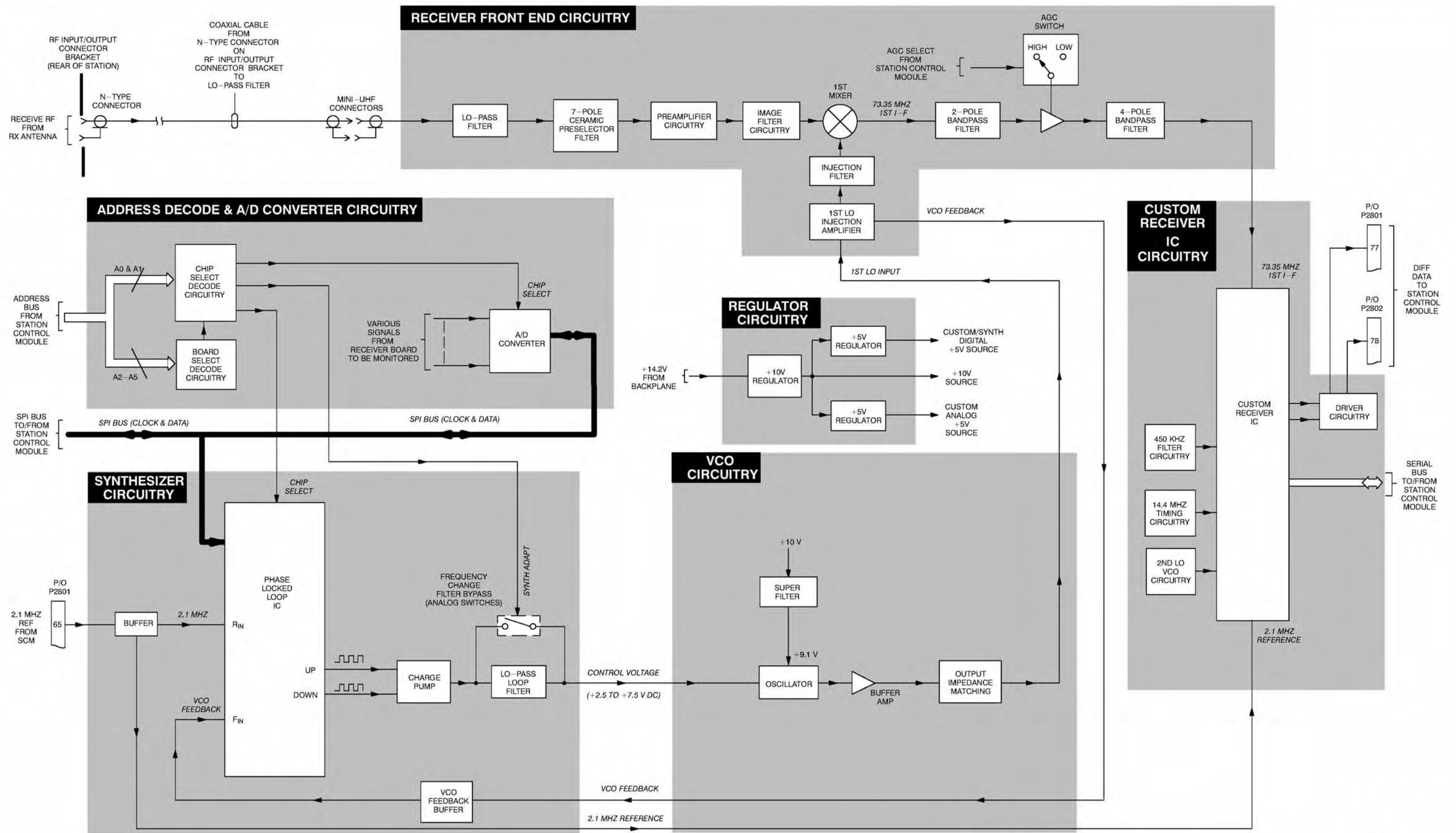

Figure 2. Quantro/Quantar 800 MHz Receiver Module Functional Block Diagram



## 1 DESCRIPTION

The *Quantar/Quantro* 900 MHz Receiver Module is described in this section. A general description, identification of controls, indicators, and inputs/outputs, a functional block diagram, and functional theory of operation are provided. The information provided is sufficient to give service personnel a functional understanding of the module, allowing maintenance and troubleshooting to the module level. (Refer also to the Maintenance and Troubleshooting section of this manual for detailed troubleshooting procedures for all modules in the station.)

### General Description

The Receiver Module provides the receiver functions for the *Quantar/Quantro* 900 MHz station. The receiver module is comprised of a Receiver Board and a ceramic preselector (mounted on board), all contained within a slide-in module housing. The receiver module performs highly selective bandpass filtering and dual down conversion of the station receive rf signal. A custom receiver IC then performs an analog to digital conversion of the received signal and outputs a differential data signal to the Station Control Module.

### Overview of Circuitry

The receiver module contains the following circuitry:

- Frequency Synthesizer Circuitry— consisting of a phase-locked loop and VCO, generates the 1st LO injection signal
- Ceramic Preselector Filter — provides 7-pole bandpass filtering of the station receive rf input
- Receiver Front End Circuitry — performs filtering, amplification, and the 1st down conversion of the receive rf signal
- Custom Receiver IC Circuitry — consists of a custom IC which performs the 2nd down conversion, filtering, amplification, and analog to digital conversion of the receive signal
- Address Decode & A/D Converter Circuitry — performs address decoding to provide board and chip select signals; also converts analog status signals to digital format for transfer to Station Control Module
- Local Power Supply Regulation — accepts +14.2V dc input and outputs +10V and +5V dc operating voltages

## 2 CONTROLS, INDICATORS, AND INPUTS/OUTPUTS

Figure 1 shows the receiver module controls, indicators, and all input and output external connections.

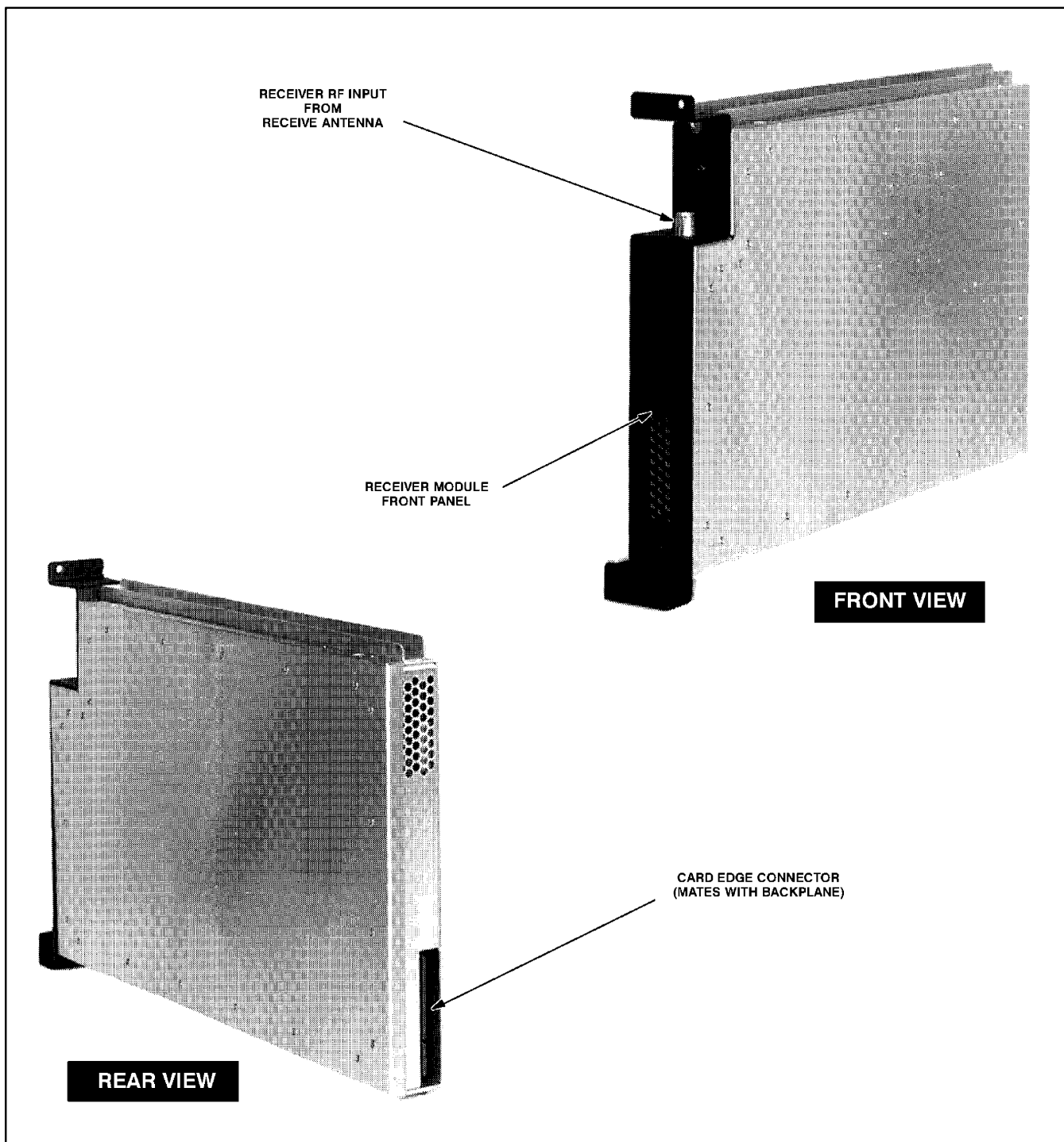

**Figure 1.** Quantar/Quantro 900 MHz Receiver Module Controls, Indicators, and Inputs/Outputs

# 3

## FUNCTIONAL THEORY OF OPERATION

The following theory of operation describes the operation of the receiver circuitry at a functional level. The information is presented to give the service technician a basic understanding of the functions performed by the module in order to facilitate maintenance and troubleshooting to the module level. Refer to Figure 2 for a block diagram of the receiver module.

### Synthesizer and VCO Circuitry

#### **Introduction**

The synthesizer and VCO circuitry generate the 1st LO injection signal for the 1st mixer in the receiver front end circuitry. Functional operation of these circuits is as follows.

#### **Phase-Locked Loop**

The phase-locked loop (PLL) IC receives frequency selection data from the Station Control Module microprocessor. Once programmed, the PLL IC compares a 2.1 MHz reference signal (from the Station Control Module) with a feedback sample of the VCO output. Depending on whether the feedback signal is higher or lower in frequency than the 2.1 MHz reference, correction pulses are generated. (The width of these correction pulses is dependent on the amount of difference between the 2.1 MHz reference and the VCO feedback.)

The up/down pulses from the PLL IC are fed to a charge pump which outputs a dc voltage proportional to the pulse widths. This dc voltage is then low-pass filtered and fed to the VCO as the *CONTROL VOLTAGE*. (Note that if a frequency change is requested by the microprocessor, the low-pass loop filter is momentarily bypassed to accelerate the frequency change.)

#### **VCO**

The dc control voltage from the synthesizer is fed to a VCO which generates the 1st LO injection signal. The VCO responds to the dc control voltage and generates the appropriate rf signal. This signal is fed through a buffer amplifier and impedance matching and output to the 1st LO injection amplifier in the receiver front end circuitry. A sample of the injection signal is returned to the PLL IC (via a feedback buffer) to serve as a VCO feedback signal.

---

## Receiver Front End Circuitry

The receive rf input is fed from the antenna through a low-pass filter to a 7-pole ceramic preselector filter which provides highly selective bandpass filtering. The output of the preselector filter is then amplified, image filtered, and fed to one input of the 1st mixer. The signal is mixed with the 1st LO injection signal (generated by the synthesizer/VCO circuitry) to produce a 73.35 MHz 1st i-f signal.

The 1st i-f signal is 2-pole bandpass filtered and fed to an amplifier. The amplifier gain (high or low) is determined by an AGC switch circuit that is controlled by an AGC select signal from the Station Control Module. The amplified 1st i-f signal is then 4-pole bandpass filtered and fed to the rf input of the custom receiver IC.

---

## Custom Receiver IC Circuitry

The custom receiver IC provides additional amplification, filtering, a second down conversion, and finally analog to digital conversion of the 2nd i-f signal. The digital receive signal is then sent via differential driver circuitry to the Station Control Board. This data signal contains the necessary I and Q quadrature information, AGC information, and other data transfer information required by the Station Control Module to process the receive signal. (Note that the recovered audio signal is in digital format throughout the station circuitry, resulting in a more noise-free, linear receiver. Analog audio is present only in the external speaker driver circuitry on the Station Control Board and on the Wireline Interface Board at the phone line connections to and from the station.)

The remainder of the custom receiver IC circuitry consists of timing and tank circuits to support the internal oscillator, 2nd LO synthesizer circuitry, and 2nd i-f circuitry.

A serial bus allows data communications between the custom receiver IC and the DSP ASIC located on the Station Control Board. This bus allows the DSP ASIC to control various current and gain settings, establish the data bus clock rate, program the 2nd LO, and perform other control functions.

---

## Address Decode and A/D Converter Circuitry

### **Address Decode Circuitry**

The address decode circuitry allows the Station Control Board to use the address bus to select a specific device on a specific station board for control or data communications purposes (via the SPI bus). If the board select circuitry decodes address lines A2 thru A5 as the receiver module address, it enables the chip select circuitry. The chip select circuitry then decodes address lines A0 and A1 and generates chip select signals for the PLL and A/D converter and the *SYNTH ADAPT* signal to control the loop filter bypass switch in the synthesizer circuitry.

### **A/D Converter Circuitry**

Analog signals from various strategic operating points throughout the receiver board are fed to the A/D converter, which converts them to a digital signal and, upon request by the Station Control Module, outputs the signal to the Station Control Module via the SPI bus.

---

## Voltage Regulator Circuitry

The voltage regulator circuitry consists of +10V and two +5V regulators. The +10V regulator accepts a +14.2V dc input and generates a +10V dc operating voltage for the receiver board circuitry.

The +10V regulator output also feeds two +5V regulators which output Custom Analog +5V and Custom Digital +5V dc operating voltages to supply the custom receiver IC and Synthesizer IC. In addition, a +5V dc operating voltage is input at the backplane (from the station power supply) to supply Digital +5V to the remainder of the receiver board circuitry.

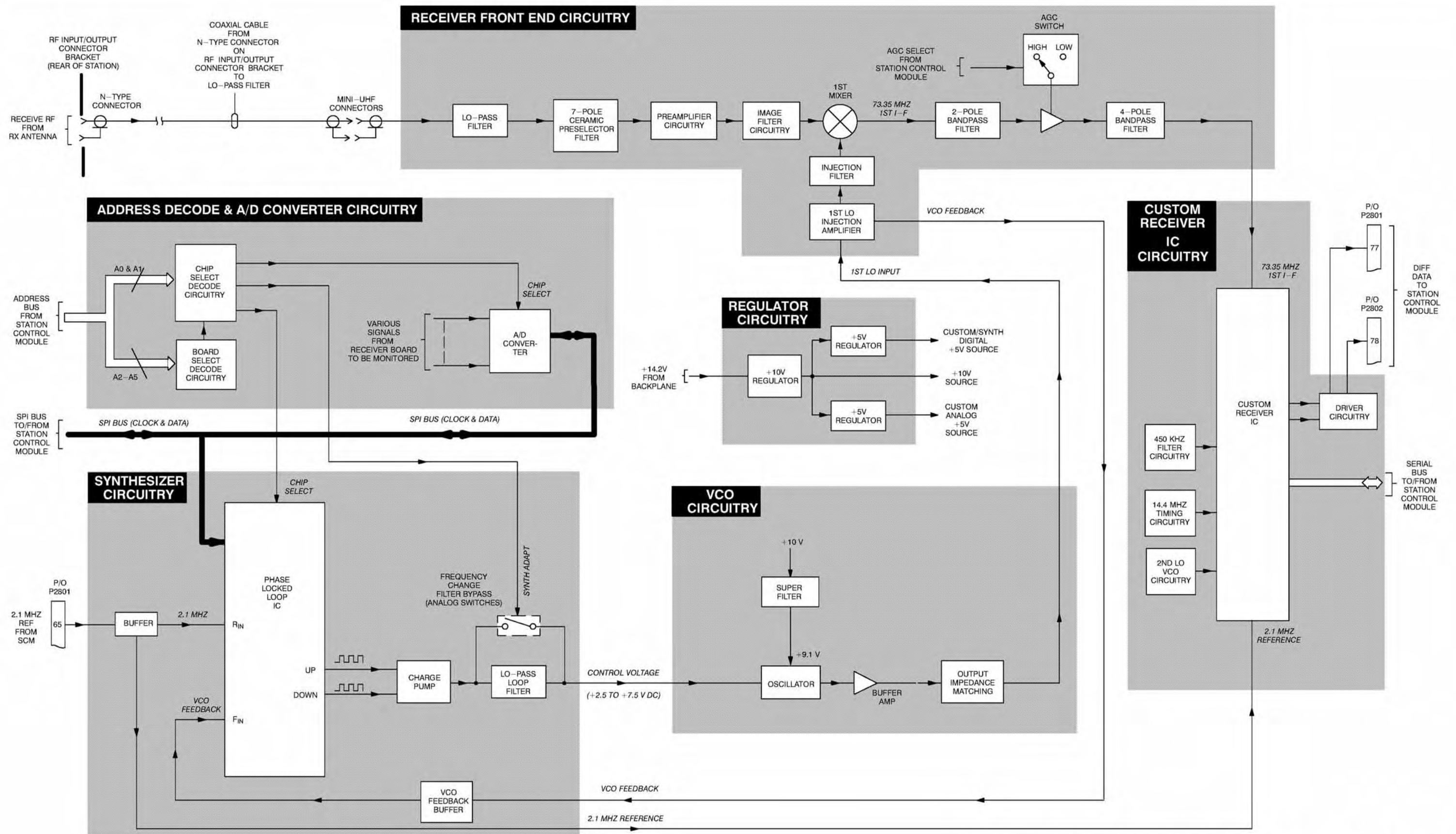

Figure 2. Quantar/Quantro 900 MHz Receiver Module Functional Block Diagram

**MODELS** TLD9831A-D (132–154 MHz)  
TLD9832A-D (150–174 MHz)  
CLX4000A (380–433 MHz)  
TLE5971A-F (403–433 MHz)  
TLE5972A-F (438–470 MHz)  
TLE5973A-F (470–494 MHz)  
TLE5974A-F (494–520 MHz)  
TLF6920A-G (850–870 MHz)  
TLF6930A-G (935–941 MHz)

## 1 DESCRIPTION

The TLD9831A/32, CLX4000A, TLE5971 thru 74, TLF6920, and TLF6930 Exciter Boards are described in this section. A general description, identification of controls, indicators, and inputs/outputs, a functional block diagram, and functional theory of operation are provided. The information provided is sufficient to give service personnel a functional understanding of the module, allowing maintenance and troubleshooting to the module level. (Refer also to the Maintenance and Troubleshooting section of this manual for detailed troubleshooting procedures for all modules in the station.)

### General Description

The Exciter Board (in conjunction with the Power Amplifier Module) provides the transmitter functions for the *Quantar* and *Quantro* stations. Contained within a slide-in module housing, the exciter board generates a low-level modulated rf signal which is input to the power amplifier module for further amplification and output to the transmit antenna.

These Exciter Boards differ only in the range of operation, as shown in the title of this section. Unless otherwise noted, the information provided in this section applies to all models.

### Overview of Circuitry

The exciter board contains the following circuitry:

- Microprocessor — serves as the main controller for the exciter board; provides control, monitoring of signals, and interfaces with the Station Control Module microprocessor over a serial bus
- Frequency Synthesizer Circuitry— consisting of a phase-locked loop and VCO, generates a modulated rf signal at the transmitter carrier frequency
- Transmitter Power Control — generates a dc control voltage which controls the output power of the power amplifier module
- RF Switch — allows the microprocessor to turn on/off the exciter output signal to the power amplifier module

## 2 CONTROLS, INDICATORS, AND INPUTS/OUTPUTS

Figure 1 shows the exciter module controls, indicators, and all input and output external connections.

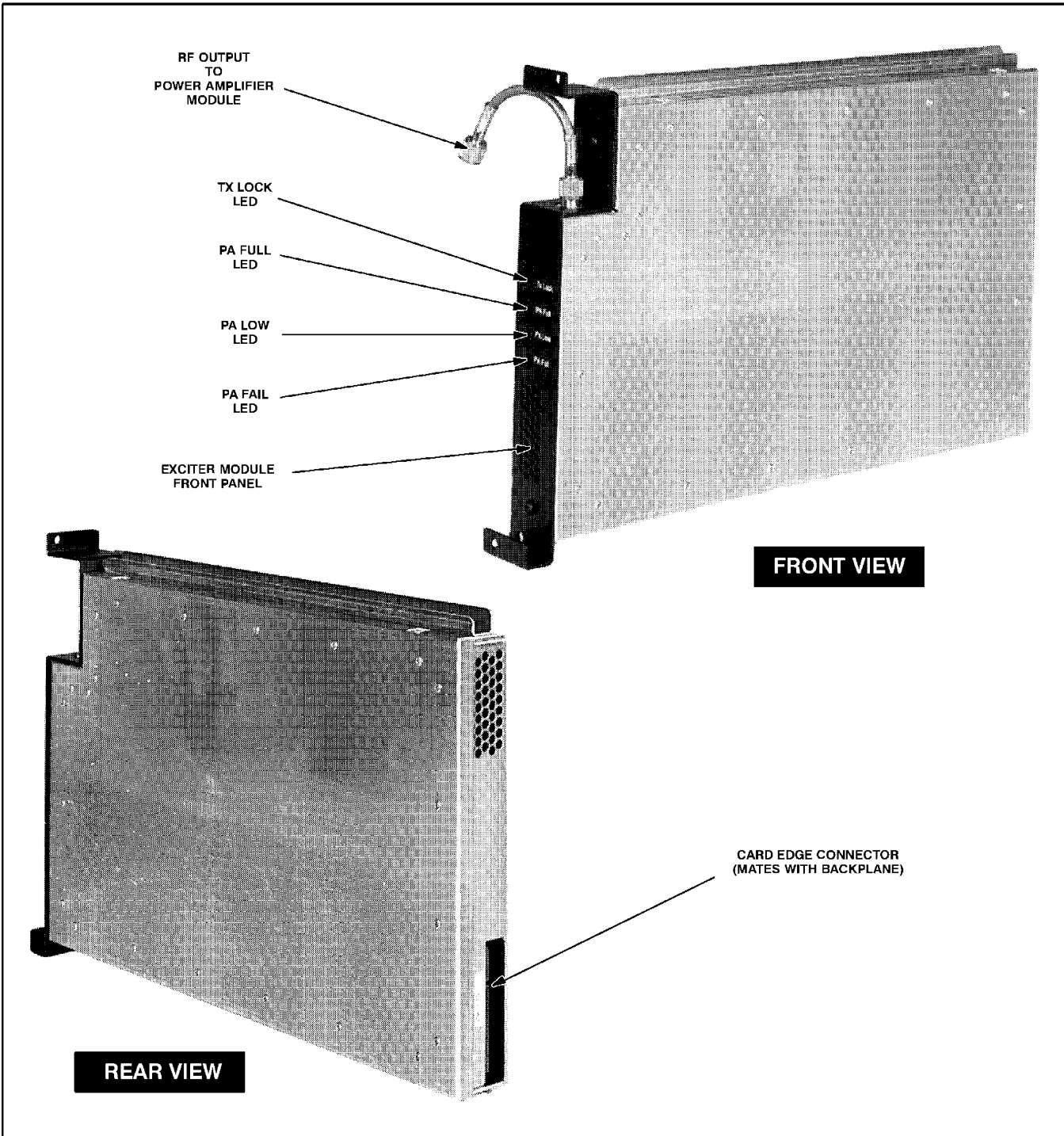

**Figure 1.** Exciter Module Controls, Indicators, and Inputs/Outputs



# 3

## FUNCTIONAL THEORY OF OPERATION

The following theory of operation describes the operation of the exciter circuitry at a functional level. The information is presented to give the service technician a basic understanding of the functions performed by the module in order to facilitate maintenance and troubleshooting to the module level. Refer to Figure 2 for a block diagram of the exciter module.

### Synthesizer and VCO Circuitry

#### Introduction

As mentioned previously, the exciter module generates a low-level modulated rf signal which is input to the power amplifier module. The rf carrier is generated by a frequency synthesizer consisting of synthesizer circuitry and VCO circuitry. Functional operation of these circuits is as follows.

#### Phase-Locked Loop

The phase-locked loop (PLL) IC receives frequency selection data from the microprocessor. Once programmed, the PLL IC compares a 2.1 MHz reference signal (from the Station Control Module) with a feedback sample of the VCO output. Depending on whether the feedback signal is higher or lower in frequency than the 2.1 MHz reference, correction pulses are generated. (The width of these correction pulses is dependent on the amount of difference between the 2.1 MHz reference and the VCO feedback.)

The up/down pulses from the PLL IC are fed to a charge pump which outputs a dc voltage proportional to the pulse widths. This dc voltage is then low-pass filtered and fed to the VCO as the *CONTROL VOLTAGE*. (Note that if a frequency change is requested by the microprocessor, the low-pass loop filter is momentarily bypassed to accelerate the frequency change.)

#### VCO

The dc control voltage from the synthesizer is fed to dual VCOs which generate the rf carrier signal. Within each band (VHF-R1, R2, UHF-R0, R1, R2, R3, R4, and 800 MHz), one VCO generates signals in the upper half of the band, while the other VCO generates signals in the lower half of the band. Only one VCO is active at a time. Selection of the active VCO is provided by a *BANDSHIFT* signal from the PLL IC.

The active VCO responds to the dc control voltage and generates the appropriate rf signal. This signal is fed through impedance matching, amplification, and filtering and is output to the RF Switch Circuitry. A sample of the output is returned to the PLL IC to serve as a VCO feedback signal.

**Note:** 800 MHz and 900 MHz Exciter Modules have only one VCO which operates over the entire 900 MHz range.

---

## Synthesizer and VCO Circuitry (Continued)

### **Modulation**

The active VCO receives an audio/data modulation signal from the Station Control Module via two low-pass filters. This modulation signal modulates the active VCO to produce a modulated low-level rf carrier signal.

Low-frequency modulation signals (below the loop filter corner) tend to be interpreted by the PLL as VCO frequency error. A modulation compensation signal is added to the PLL control voltage to cancel out this effect and allow for low frequency modulation.

---

## RF Switch Circuitry

The modulated rf signal from the VCO is fed through an attenuator to an rf switch circuit. Signal *TX ENABLE* from the microprocessor controls the switch. The rf signal is output to a mini-UHF connector mounted in a recess in the module front cover. An rf cable connects the exciter output to the power amplifier module.

---

## Microprocessor Circuitry

### **Introduction**

The microprocessor ( $\mu$ P) serves as the main controller for the exciter module circuitry. The  $\mu$ P provides the following functions.

### **Communications with Station Control Module**

Data communications between the exciter  $\mu$ P and the Station Control Module  $\mu$ P is performed via a serial peripheral interface (SPI) bus. This bus allows the SCM  $\mu$ P to interrogate the exciter  $\mu$ P (to obtain status and alarm information) and to issue commands to the exciter  $\mu$ P (to select frequency and output power). The SPI bus is also used to allow the exciter  $\mu$ P to send data to the synthesizer PLL IC (to select frequency) and the D/A Converter IC (to control output power).

### **Monitoring External Signals**

The exciter  $\mu$ P accepts input signals from various sources, including portions of the exciter circuitry and from the power amplifier module. These signals are input to the  $\mu$ P through analog multiplexers where they are monitored. The levels on these status lines are used by the  $\mu$ P to control the operation of the exciter circuitry and to report to the SCM  $\mu$ P.

### **EPROM**

The  $\mu$ P operating program and various algorithms for frequency and output power control are stored in an EPROM. The  $\mu$ P accesses the EPROM via an address bus and a data bus.

---

## Microprocessor Circuitry (Continued)

### **Output Control Signals**

Various output control signals from the  $\mu\text{P}$  are fed to latches via the data bus. These signals include *PA KEY*, *TX ENABLE*, and the control signals for the front panel LEDs. Other control signals are provided to portions of the exciter module circuitry, as well as to the Power Amplifier Module.

### **Exciter ID Resistor ROM**

A resistor network ROM provides exciter ID information to the  $\mu\text{P}$ . This information defines in which band and range (e.g., VHF—Range 1, UHF, 900 MHz, etc.) the particular exciter is designed to operate.

### **Oscillator Circuitry**

The clock signal for the  $\mu\text{P}$  is generated by internal circuitry and an external 8.0000 MHz crystal circuit.

---

## TX Power Control Circuitry

### **A/D Converter**

The TX Power Control Circuitry consists of an D/A converter and a custom Power Control IC. Upon station power-up, the exciter  $\mu\text{P}$  sends data to the D/A converter (via the SPI bus) to select the desired output power (in Watts) from the power amplifier. The D/A converter outputs a dc reference voltage proportional to the selected output power.

### **Power Control IC**

The Power Control IC generates a dc power control voltage (*V\_CONT*) which is fed to the power amplifier module to control the output power. A forward power detect (*TX\_VF*) signal (dc voltage proportional to the output power from the power amplifier) is fed back to the Power Control IC. The Power Control IC compares the *TX\_VF* signal with the *POWER SELECT* voltages from the A/D converter and adjusts *V\_CONT* accordingly to obtain the selected output power. This “feedback and control loop” continually monitors the *TX\_VF* signal and adjusts *V\_CONT* to maintain a constant output power at the selected level.

### **Monitoring of Loop Status**

A sample of the dc power control voltage (*V\_CONT*) is fed back to the  $\mu\text{P}$  via the analog multiplexer to allow the  $\mu\text{P}$  to monitor the status of the power control loop. Inability of the power amplifier to output the selected power (as indicated by *V\_CONT* going to the maximum level) results in the  $\mu\text{P}$  re-programming the A/D converter to select a lower output power level. If after two reductions in selected power the power amplifier still cannot output the selected power, the  $\mu\text{P}$  initiates “shut down” mode by selecting 0 Watts and turning the rf switch OFF.



## 1 DESCRIPTION

The Models TLD3110 and TLD3101/TLD3102 Power Amplifier Modules are described in this section. A general description, identification of controls, indicators, and inputs/outputs, functional block diagrams, and functional theory of operation are provided. The information provided is sufficient to give service personnel a functional understanding of the module, allowing maintenance and troubleshooting to the module level. (Refer also to the Maintenance and Troubleshooting section of this manual for detailed troubleshooting procedures for all modules in the station.)

### General Description

The Power Amplifier Module (PA) accepts a low-level modulated rf signal from the Exciter Module and amplifies the signal for transmission via the site transmit antenna. The output power is continually monitored and regulated by a feedback and control loop, with a power output control voltage being generated by the transmitter control circuitry located in the Exciter Module.

The Models TLD3110 and TLD3101/TLD3102 PA Modules are very similar in design and function, with the major differences being the output power capabilities and operating frequency range. Unless otherwise noted, the information provided in this section applies to all three models.

### Overview of Circuitry

The PA contains the following circuitry:

- Intermediate Power Amplifier (IPA) — low-level amplifier stage which is controlled by the transmitter control voltage from the Exciter Module; provides an output of approximately 0 to 10W
- Driver Power Amplifier (DPA) — contained in 25W PA only, provides final amplification of the IPA output; provides an output of 35W maximum
- Final Power Amplifier (FPA) — contained in 125W PA only, provides final amplification of the IPA output; provides an output of 160W maximum
- Circulator — provides PA module output isolation
- Harmonic Filter/Coupler — suppresses harmonic radiation and couples the PA output to the transmit antenna connector; also serves as a power meter
- Sense and Detect Circuitry — provides sense and detect signals for critical signal points throughout the circuitry; signals are monitored by the Exciter Module

## 2 CONTROLS, INDICATORS, AND INPUTS/OUTPUTS

Figure 1 shows the PA controls, indicators, and all input and output external connections.

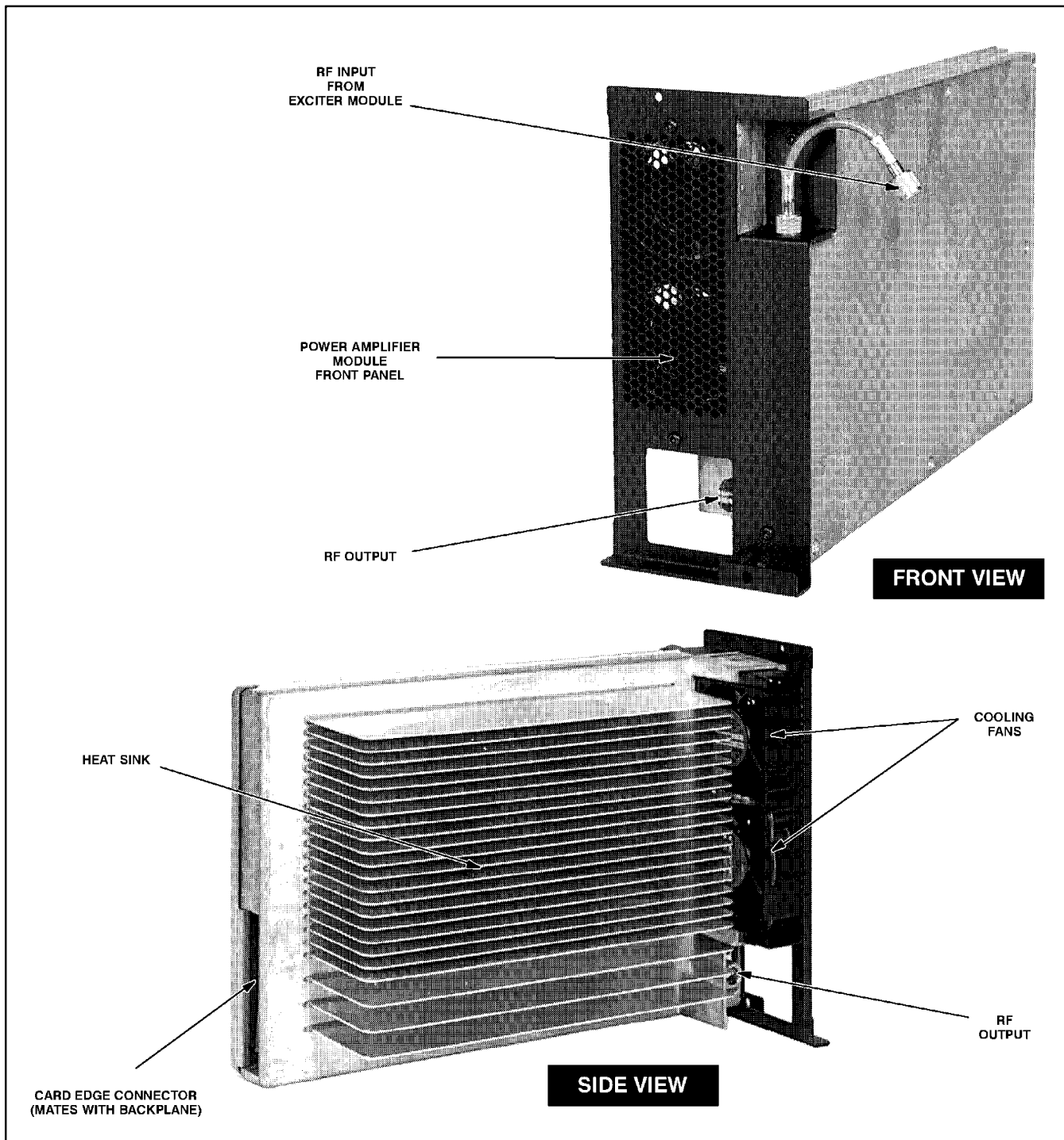

**Figure 1.** Power Amplifier Module Controls, Indicators, and Inputs/Outputs (125 W Model Shown)

## 3 FUNCTIONAL THEORY OF OPERATION

The following theory of operation describes the operation of the PA circuitry at a functional level. The information is presented to give the service technician a basic understanding of the functions performed by the module in order to facilitate maintenance and troubleshooting to the module level. Functional block diagrams are provided in Figure 2 (TLD3110, 25 W) and Figure 3 (TLD3101/TLD3102, 125 W). As mentioned previously, the four PA modules are similar in design and function. The following theory of operation applies to all four modules except where noted.

### RF Signal Path

A low-level modulated rf signal (approximately +13 dBm) from the Exciter module is input to the PA module via a coax cable. The signal is input to the IPA and amplified to approximately 0 to 10W [depending on the dc power control voltage (V\_CONT) from the Exciter Module].

The IPA output is fed to a DPA (25W) or an FPA (125W), where final amplification occurs. The output of the DPA (35W maximum) or FPA (160W maximum) is fed to a circulator, which passes the transmit signal to the harmonic filter/coupler, while routing all reflected power to a 50Ω load.

The output of the circulator is fed to the harmonic filter/coupler. This circuit provides highly selective bandpass filtering and couples the signal to an N-type connector mounted to the module casting. A coax cable routes the signal to an N-type connector mounted on an rf input/output connector bracket located on the rear of the station.

### Output Power Control

Note that V\_OMNI does not control the output level of the DPA directly but serves as on/off control for the DPA stage.

A feedback and control loop configuration is used to regulate the PA output power. The Harmonic Filter/Coupler generates a dc voltage proportional to the PA Module output power. This voltage (TX\_VF) is fed to the TX Power Control Circuitry in the Exciter Module. The TX\_VF voltage is compared to reference voltages to generate a dc power control voltage (V\_CONT).

The dc power control voltage (V\_CONT) is output from the Exciter Module and fed through filtering circuitry in the PA to a voltage translation and current limiting circuit. The output of this circuitry is V\_OMNI, a dc voltage which controls the output power of the IPA.

**Summary of Power Control Operation** — By controlling the output level of the IPA (range of 0 to 10W), the output power of the PA module is established. The feedback and control loop (TX\_VF fed back to Exciter Module resulting in V\_CONT to control IPA output) continually monitors and maintains the proper output power from the PA.

---

## Sense and Detect Circuitry

### **Introduction**

The PA is equipped with several sense and detect circuits to provide status signals to the Exciter Module. In most cases, the Exciter Module microprocessor uses these signals to determine PA operating conditions and, in response, varies certain control signals to correct output power, turn on cooling fans, etc. The sense and detect circuits are described in the following paragraphs.

### **Current Sensing Circuitry (25W)**

**IPA and DPA** current sense circuitry (comprised of two differential amplifiers and two sensing resistors) meters the current being drawn by the IPA and the DPA and outputs two dc signals directly proportional to the IPA and DPA currents. Circuit operation is described in the following paragraph.

In each of the current sense circuits, a differential amplifier measures the voltage drop across a sensing resistor and outputs a dc voltage directly proportional to the current through the resistor. The dc voltage (IPA\_I or DPA\_I ) is fed to the Exciter Module (via an analog multiplexer and filtering circuitry) where it is used in calculating the current being drawn by the IPA or DPA.

### **Current Sensing Circuitry (125W)**

**IPA** current sense circuitry (comprised of a differential amplifier and a sensing resistor) meters the current being drawn by the IPA and outputs a dc signal directly proportional to the IPA current. Circuit operation is described in the following paragraph.

The differential amplifier measures the voltage drop across a sensing resistor and outputs a dc voltage directly proportional to the IPA current. The dc voltage (IPA\_I) is fed to the Exciter Module (via an analog multiplexer and filtering circuitry) where it is used in calculating the current being drawn by the IPA.

**FPA** current sense circuitry (comprised of two differential amplifiers and two sensing resistors) meters the current being drawn by the FPA (side A and side B) and outputs two dc signals directly proportional to the currents for side A and side B. Circuit operation is described in the following paragraph.

In each of the current sense circuits, a differential amplifier measures the voltage drop across a sensing resistor and outputs a dc voltage directly proportional to the current through the resistor. The dc voltages (FPA\_I1\_A and FPA\_I1\_B) is fed to the Exciter Module (via an analog multiplexer and filtering circuitry) where it is used in calculating the current being drawn by the FPA (side A or side B).



---

## Sense and Detect Circuitry (Continued)

### ***PA Temperature Sense***

A thermistor and buffer circuit provides a dc voltage proportional to the PA temperature. This signal (PA\_TEMP) is fed to the Exciter Module, which monitors the signal and reduces the PA output power [by reducing the dc power control voltage (V\_CONT)] if the PA temperature exceeds set limits.

### ***IPA, DPA, and FPA Detect Circuitry***

Detection circuits provide a dc voltage approximately proportional to the rf outputs of the IPA, DPA (25W), and FPA (125W) stages. These dc signals (IPA\_VF, DPA\_VF, and FPA\_VF, used for diagnostic purposes only) are fed to the Exciter Module via an analog multiplexer and filter circuitry.

### ***Reflected Power Detect Circuitry***

The Harmonic Filter/Coupler provides a dc voltage approximately proportional to the reflected power at the output of the stage. This dc signal (TX\_VR) is fed to the Exciter Module via an analog multiplexer and filter circuitry. The signal indicates the amount of potentially harmful reflected power at the PA output. If the reflected power exceeds a set limit, the Exciter Module will shut down the PA.

### ***V\_OMNI Detect Circuitry***

A voltage divider circuit provides a dc voltage approximately proportional to the V\_OMNI control voltage from the Voltage Translator & Current Limiter circuit. This dc signal (V\_OMNI\*) is fed to the Exciter Module via an analog multiplexer and filter circuitry.

### ***+14V Detect Circuitry***

A voltage divider circuit provides a dc voltage approximately proportional to the +14 V dc input voltage from the station Power Supply Module. This dc signal (14.2V\_REF\*) is fed to the Exciter Module via an analog multiplexer and filter circuitry.

### ***+28V Detect Circuitry (125W Only)***

A voltage divider circuit provides a dc voltage approximately proportional to the +28 V dc input voltage from the station Power Supply Module. This dc signal (28V\_REF\*) is fed to the Exciter Module via an analog multiplexer and filter circuitry.

---

## Cooling Fans Control Circuitry (125 W Models Only)



The cooling fans in the PA Module are thermostatically controlled and may come on at any time during station operation. Keep fingers clear of fan blades.

The PA is equipped with a dual fan module to provide forced air cooling of the PA. The fan module is controlled by a FAN ON signal from the Exciter Module, which is fed to a driver circuit in the PA Module. The Fan Driver/Detect Circuitry controls the power to the fans via two feed-thru pins in the PA chassis which mate with the power connector on the slide-in fan module. The fans are turned on only when the temperature in the PA exceeds a set limit. It is normal for the fans to cycle on and off during station operation.

The Fan Driver/Detect Circuitry also monitors the current to the fans and feeds a dc detect voltage to the Fan Status Circuitry, which outputs a status signal indicating whether the fan current is above or below a predetermined range. The status signal (FAN\_ALARM) is fed to the Exciter Module via an analog multiplexer and filter circuitry.

---

## Power Amplifier ID Resistor ROM

A resistor network “ROM” provides power amplifier ID information to the Exciter Module via an analog multiplexer and filter circuits. This information includes the band and range in which the PA is designed to operate (e.g., VHF–Range 1, UHF, 900 MHz, etc.) and the maximum output power (e.g., 25 W, 125 W, etc.).

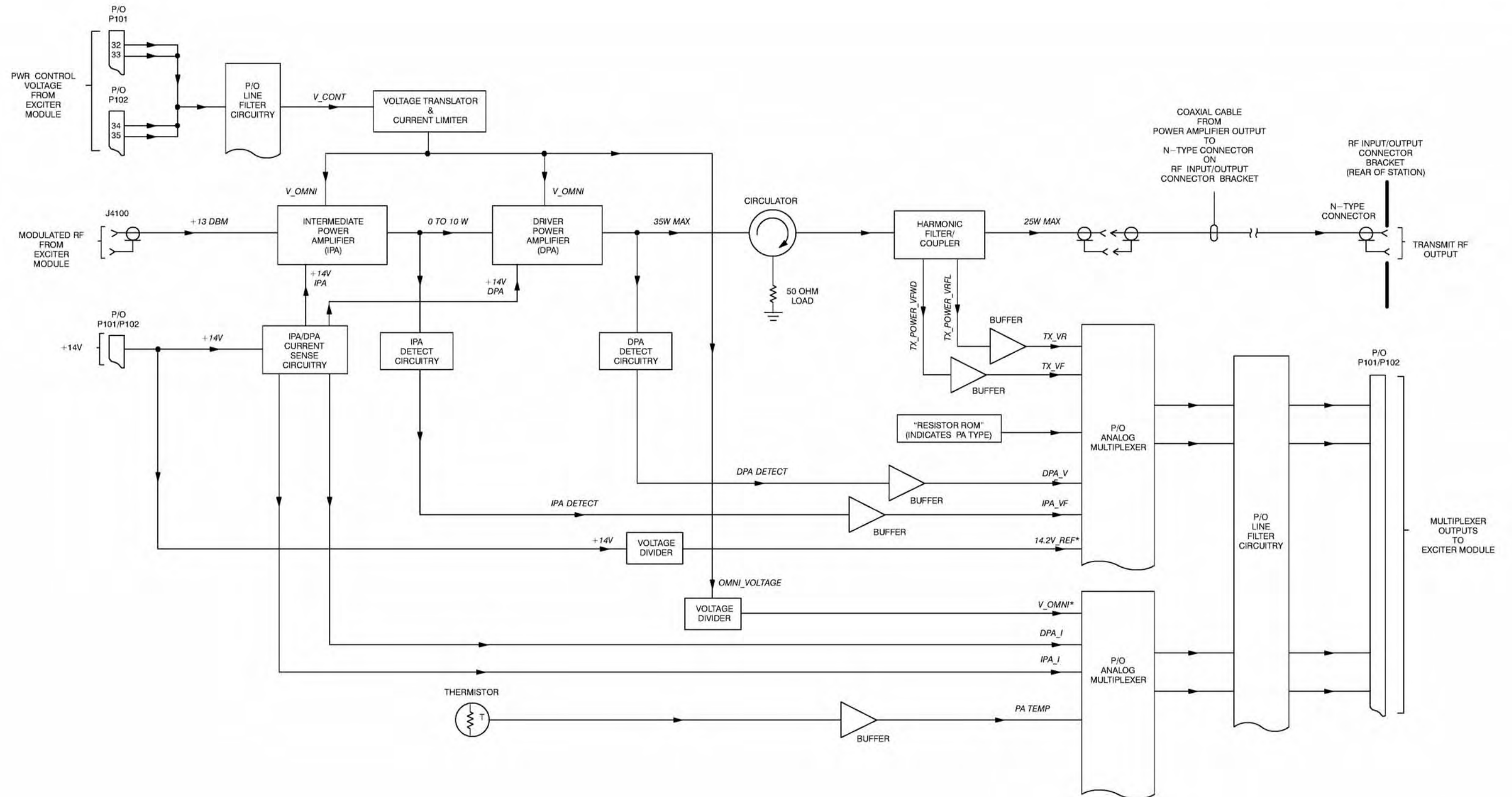

Figure 2. TLD3110 25W Power Amplifier Module Functional Block Diagram

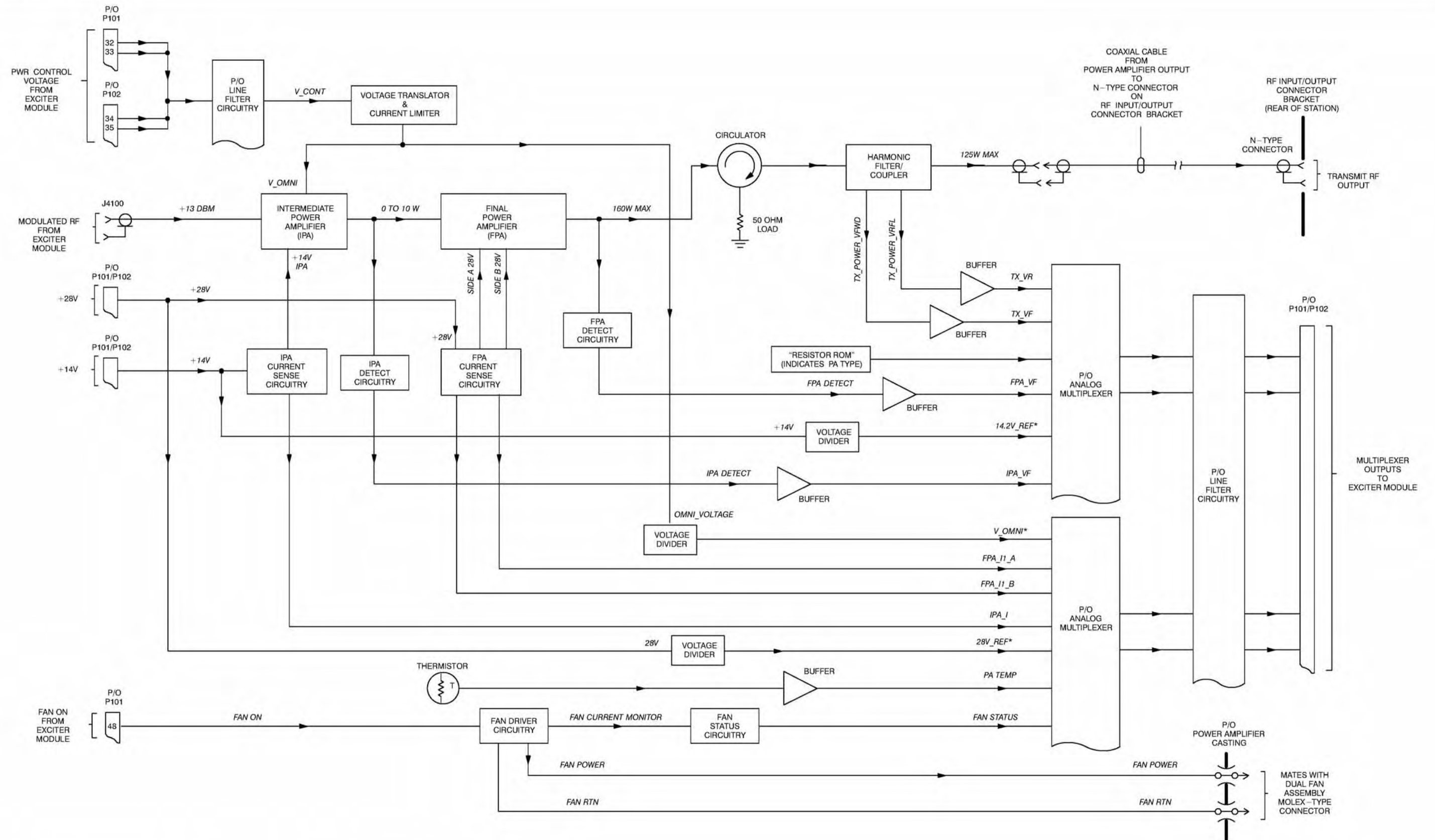

Figure 3. TLD3101/TLD3102 125W Power Amplifier Module Functional Block Diagram

**MODELS: TLE2731A (25W, UHF Range 1)**  
**TLE2732A (25W, UHF Range 2)**  
**CTX1146A (110W, UHF Range 0)**  
**TTE2061A (110W, UHF Range 1)**  
**TTE2062A (110W, UHF Range 2)**  
**TTE2063A (110W, UHF Range 3)**  
**TTE2064A (100W, UHF Range 4)**

## 1 DESCRIPTION

The Models TLE2731A, TLE2732A, CTX1146A, TTE2061A, TTE2062A, TTE2063A, and TTE2064A Power Amplifier Modules are described in this section. A general description, identification of controls, indicators, and inputs/outputs, functional block diagrams, and functional theory of operation are provided. The information provided is sufficient to give service personnel a functional understanding of the module, allowing maintenance and troubleshooting to the module level. (Refer also to the Maintenance and Troubleshooting section of this manual for detailed troubleshooting procedures for all modules in the station.)

### General Description

The Power Amplifier Module (PA) accepts a low-level modulated rf signal from the Exciter Module and amplifies the signal for transmission via the site transmit antenna. The output power is continually monitored and regulated by a feedback and control loop, with a power output control voltage being generated by the transmitter control circuitry located in the Exciter Module.

These PA Modules are very similar in design and function, with the major differences being the output power capabilities and operating frequency range. Unless otherwise noted, the information provided in this section applies to all three models.

### Overview of Circuitry

The PA contains the following circuitry:

- Intermediate Power Amplifier (IPA) — low-level amplifier stage which is controlled by the transmitter control voltage from the Exciter Module; provides an output of approximately 0 to 15W
- Driver Power Amplifier (DPA) — contained in 25W PA only, provides final amplification of the IPA output; provides an output of 35W max.
- Final Power Amplifier (FPA) — contained in 100/110W PAs only, provides final amplification of the IPA output; provides an output of 150W (CTX1146A) or 180W (all others) maximum
- Circulator — provides PA module output isolation
- Harmonic Filter/Coupler — suppresses harmonic radiation and couples the PA output to the transmit antenna connector; also serves as a power meter
- Sense and Detect Circuitry — provides sense and detect signals for critical signal points throughout the circuitry; signals are monitored by the Exciter Module

## 2 CONTROLS, INDICATORS, AND INPUTS/OUTPUTS

Figure 1 shows the PA controls, indicators, and all input and output external connections.

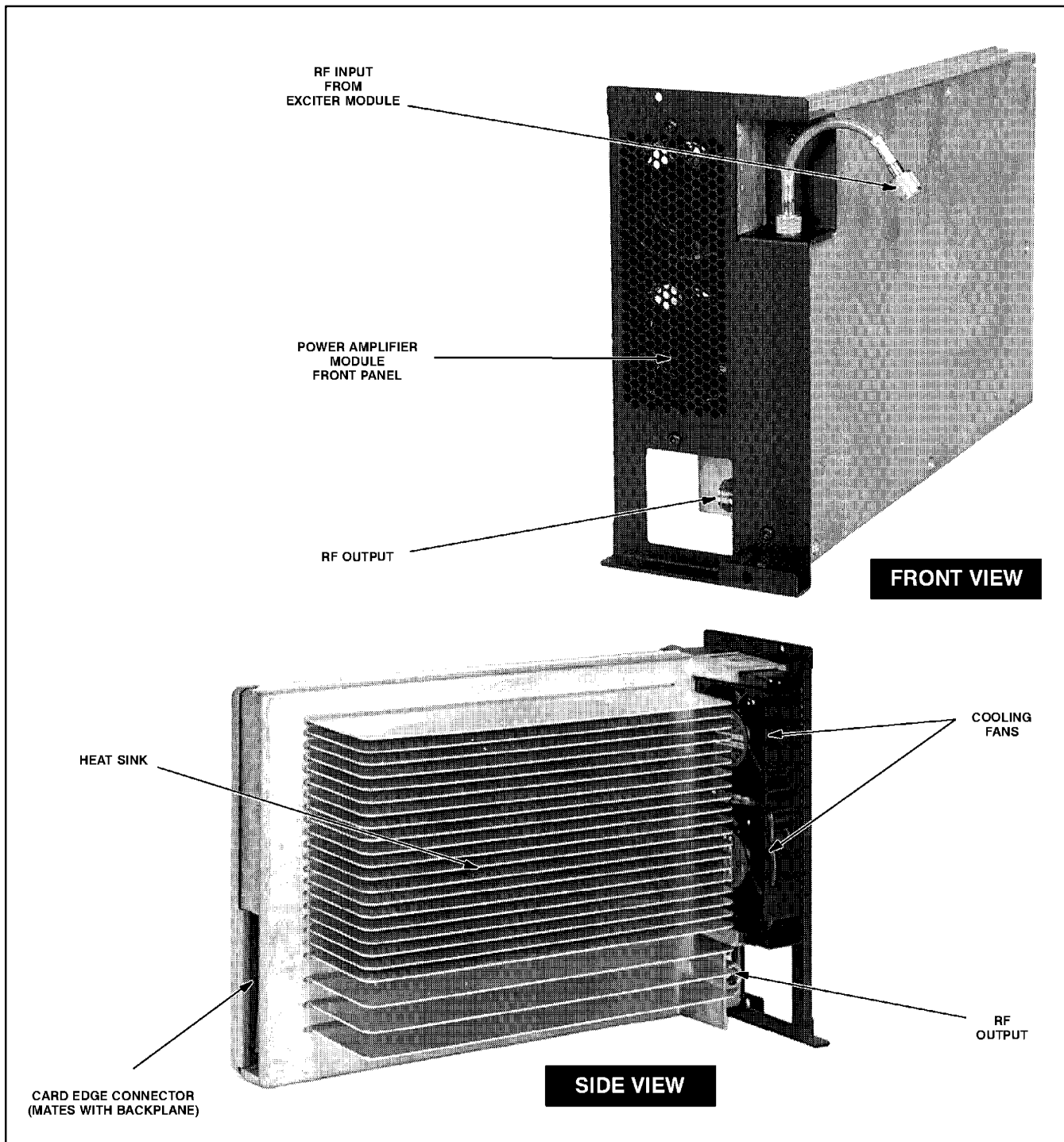

**Figure 1.** Power Amplifier Module Controls, Indicators, and Inputs/Outputs (110 W Model Shown)

## 3

## FUNCTIONAL THEORY OF OPERATION

The following theory of operation describes the operation of the PA circuitry at a functional level. The information is presented to give the service technician a basic understanding of the functions performed by the module in order to facilitate maintenance and troubleshooting to the module level. Functional block diagrams are provided in Figure 2 (TLE2731A and TLE2732A, 25 W) and Figure 3 (CTX1146A/TTE2061A–63A, 110 W and TTE2064A, 100W). As mentioned previously, the five PA modules are similar in design and function. The following theory of operation applies to all four modules except where noted.

### RF Signal Path

A low-level modulated rf signal (approximately +13 dBm) from the Exciter module is input to the PA module via a coax cable. The signal is input to the IPA and amplified to approximately 0 to 15W [depending on the dc power control voltage (V\_CONT) from the Exciter Module].

The IPA output is fed to a DPA (25W) or an FPA (100/110W), where final amplification occurs. The output of the DPA (35W maximum) or FPA (150W maximum for CTX1146, 180W maximum for all others) is fed to a circulator, which passes the transmit signal to the harmonic filter/coupler, while routing all reflected power to a 50Ω load.

The output of the circulator is fed to the harmonic filter/coupler. This circuit provides highly selective bandpass filtering and couples the signal to an N-type connector mounted to the module casting. A coax cable routes the signal to an N-type connector mounted on an rf input/output connector bracket located on the rear of the station.

### Output Power Control

A feedback and control loop configuration is used to regulate the PA output power. The Harmonic Filter/Coupler generates a dc voltage proportional to the PA Module output power. This voltage (TX\_VF) is fed to the TX Power Control Circuitry in the Exciter Module. The TX\_VF voltage is compared to reference voltages to generate and adjust a dc power control voltage (V\_CONT).

Note that V\_OMNI does not control the output level of the DPA directly but serves as on/off control for the DPA stage.

The dc power control voltage (V\_CONT) is output from the Exciter Module and fed through filtering circuitry in the PA to a voltage translation and current limiting circuit. The output of this circuitry is V\_OMNI, a dc voltage which controls the output power of the IPA.

**Summary of Power Control Operation** — By controlling the output level of the IPA (range of 0 to 15W), the output power of the PA module is established. The feedback and control loop (TX\_VF fed back to Exciter Module resulting in V\_CONT to control IPA output) continually monitors and maintains the proper output power from the PA.

## Sense and Detect Circuitry

### **Introduction**

The PA is equipped with several sense and detect circuits to provide status signals to the Exciter Module. In most cases, the Exciter Module microprocessor uses these signals to determine PA operating conditions and, in response, varies certain control signals to correct output power, turn on cooling fans, derate performance, etc. The sense and detect circuits are described in the following paragraphs.

### **Current Sensing Circuitry (25W)**

**IPA and DPA** current sense circuitry (comprised of two differential amplifiers and two sensing resistors) meters the current being drawn by the IPA and the DPA and outputs two dc signals directly proportional to the IPA and DPA currents. Circuit operation is described in the following paragraph.

In each of the current sense circuits, a differential amplifier measures the voltage drop across a sensing resistor and outputs a dc voltage directly proportional to the current through the resistor. The dc voltage (IPA\_I or DPA\_I ) is fed to the Exciter Module (via an analog multiplexer and filtering circuitry) where it is used in calculating the current being drawn by the IPA or DPA.

### **Current Sensing Circuitry (100/110W)**

**IPA** current sense circuitry (comprised of a differential amplifier and a sensing resistor) meters the current being drawn by the IPA and outputs a dc signal directly proportional to the IPA current. Circuit operation is described in the following paragraph.

The differential amplifier measures the voltage drop across a sensing resistor and outputs a dc voltage directly proportional to the IPA current. The dc voltage (IPA\_I) is fed to the Exciter Module (via an analog multiplexer and filtering circuitry) where it is used in calculating the current being drawn by the IPA.

**FPA** current sense circuitry (comprised of two differential amplifiers and two sensing resistors) meters the current being drawn by the FPA (side A and side B) and outputs two dc signals directly proportional to the currents for side A and side B. Circuit operation is described in the following paragraph.

In each of the current sense circuits, a differential amplifier measures the voltage drop across a sensing resistor and outputs a dc voltage directly proportional to the current through the resistor. The dc voltages (FPA\_I1\_A and FPA\_I1\_B) is fed to the Exciter Module (via an analog multiplexer and filtering circuitry) where it is used in calculating the current being drawn by the FPA (side A or side B).



---

## Sense and Detect Circuitry (Continued)

### ***PA Temperature Sense***

A thermistor and buffer circuit provides a dc voltage approximately proportional to the PA temperature. This signal (PA\_TEMP) is fed to the Exciter Module, which monitors the signal and reduces the PA output power [by reducing the dc power control voltage (V\_CONT)] if the PA temperature exceeds set limits.

### ***IPA, DPA, and FPA Detect Circuitry***

Detection circuits provide a dc voltage approximately proportional to the rf outputs of the IPA (15W), DPA (25W), and FPA (100/110W) stages. These dc signals (IPA\_VF, DPA\_VF, and FPA\_VF, used for diagnostic purposes only) are fed to the Exciter Module via an analog multiplexer and filter circuitry.

### ***Reflected Power Detect Circuitry***

The Harmonic Filter/Coupler provides a dc voltage approximately proportional to the reflected power at the output of the stage. This dc signal (TX\_VR) is fed to the Exciter Module via an analog multiplexer and filter circuitry. The signal indicates the amount of potentially harmful reflected power at the PA output. If the reflected power exceeds a set limit, the Exciter Module will shut down the PA.

### ***V\_OMNI Detect Circuitry***

A voltage divider circuit provides a dc voltage approximately proportional to the V\_OMNI control voltage from the Voltage Translator & Current Limiter circuit. This dc signal (V\_OMNI\*) is fed to the Exciter Module via an analog multiplexer and filter circuitry.

### ***+14V Detect Circuitry***

A voltage divider circuit provides a dc voltage approximately proportional to the +14 V dc input voltage from the station Power Supply Module. This dc signal (14.2V\_REF\*) is fed to the Exciter Module via an analog multiplexer and filter circuitry.

### ***+28V Detect Circuitry (100/110W Only)***

A voltage divider circuit provides a dc voltage approximately proportional to the +28 V dc input voltage from the station Power Supply Module. This dc signal (28V\_REF\*) is fed to the Exciter Module via an analog multiplexer and filter circuitry. The PA output power is reduced when the detected voltage is below +27V dc.

---

## Cooling Fans Control Circuitry (100/110 W Models Only)



The cooling fans in the PA Module are thermostatically controlled and may come on at any time during station operation. Keep fingers clear of fan blades.

The PA is equipped with a dual fan module to provide forced air cooling of the PA. The fan module is controlled by a FAN ON signal from the Exciter Module, which is fed to a driver circuit in the PA Module. The Fan Driver/Detect Circuitry controls the power to the fans via two feed-thru pins in the PA chassis which mate with the power connector on the slide-in fan module. The fans are turned on only when the temperature in the PA exceeds a set limit. It is normal for the fans to cycle on and off during station operation.

The Fan Driver/Detect Circuitry also monitors the current to the fans and feeds a dc detect voltage to the Fan Status Circuitry, which outputs a status signal indicating whether the fan current is above or below a predetermined range. The status signal (FAN\_ALARM) is fed to the Exciter Module via an analog multiplexer and filter circuitry.

---

## Power Amplifier ID Resistor ROM

A resistor network “ROM” provides power amplifier ID information to the Exciter Module via an analog multiplexer and filter circuits. This information includes the band and range in which the PA is designed to operate (e.g., UHF, 800 MHz, etc.) and the maximum output power (e.g., 25 W, 110 W, etc.).

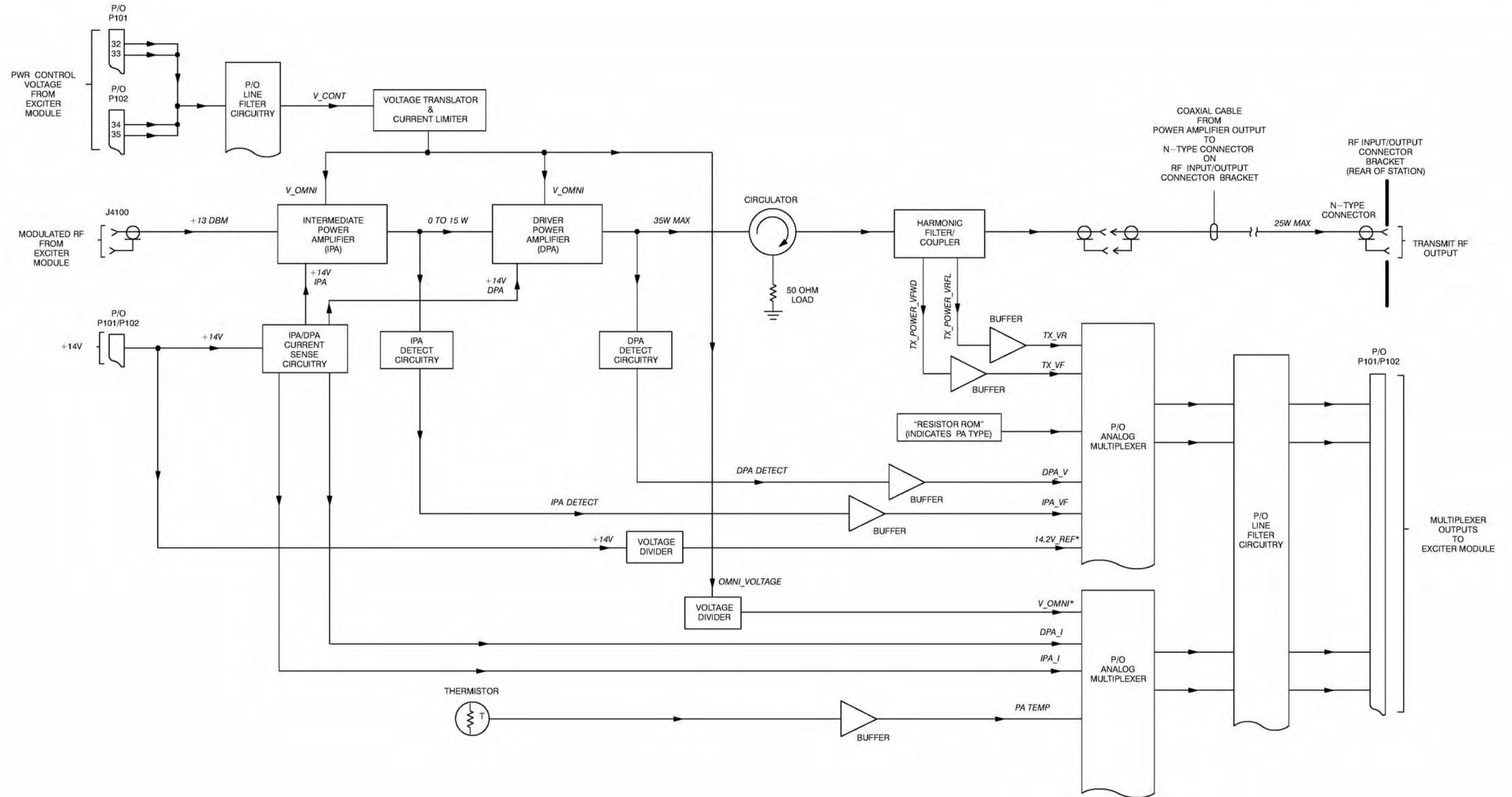

Figure 2. TLE2731A/TLE2732A 25W UHF Power Amplifier Module Functional Block Diagram

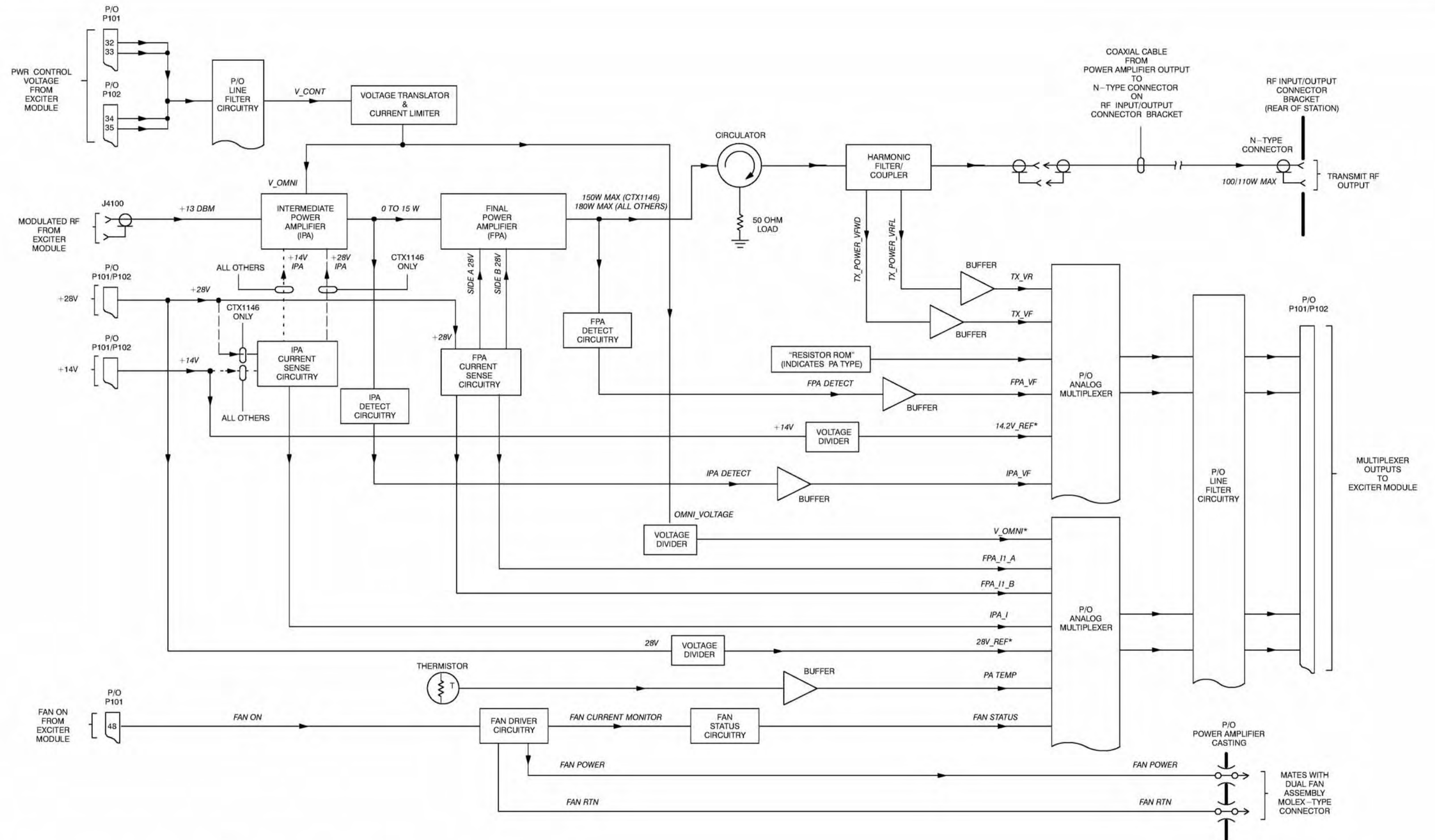

Figure 3. CTX1146A/TTE2061A-63A 110W UHF and TTE2064A 100W UHF Power Amplifier Module Functional Block Diagram

## 1 DESCRIPTION

The Models TLF1940A/TLF1930A 800 MHz and TLF1800A 900 MHz Power Amplifier Modules are described in this section. A general description, identification of controls, indicators, and inputs/outputs, functional block diagrams, and functional theory of operation are provided. The information provided is sufficient to give service personnel a functional understanding of the module, allowing maintenance and troubleshooting to the module level. (Refer also to the Maintenance and Troubleshooting section of this manual for detailed troubleshooting procedures for all modules in the station.)

### General Description

The Power Amplifier Module (PA) accepts a low-level modulated rf signal from the Exciter Module and amplifies the signal for transmission via the site transmit antenna. The output power is continually monitored and regulated by a feedback and control loop, with a power output control voltage being generated by the transmitter control circuitry located in the Exciter Module.

The PA Modules described in this section are very similar in design and function, with the major differences being the output power capabilities and operating frequency. Unless otherwise noted, the information provided in this section applies to all four models.

### Overview of Circuitry

The PA contains the following circuitry:

- Intermediate Power Amplifier (IPA) — low-level amplifier stage which is controlled by the transmitter control voltage from the Exciter Module; provides an output of approximately 0 to 10W
- Driver Power Amplifier (DPA) — provides amplification (35W maximum) of the IPA output
- Final Power Amplifier (FPA) — contained in 100W PA only, provides final amplification of the IPA output; provides an output of 160W maximum
- Circulator — provides PA module output isolation
- Harmonic Filter/Coupler — suppresses harmonic radiation and couples the PA output to the transmit antenna connector; also serves as a power meter
- Sense and Detect Circuitry — provides sense and detect signals for critical signal points throughout the circuitry; signals are monitored by the Exciter Module

## 2 CONTROLS, INDICATORS, AND INPUTS/OUTPUTS

Figure 1 shows the PA controls, indicators, and all input and output external connections.

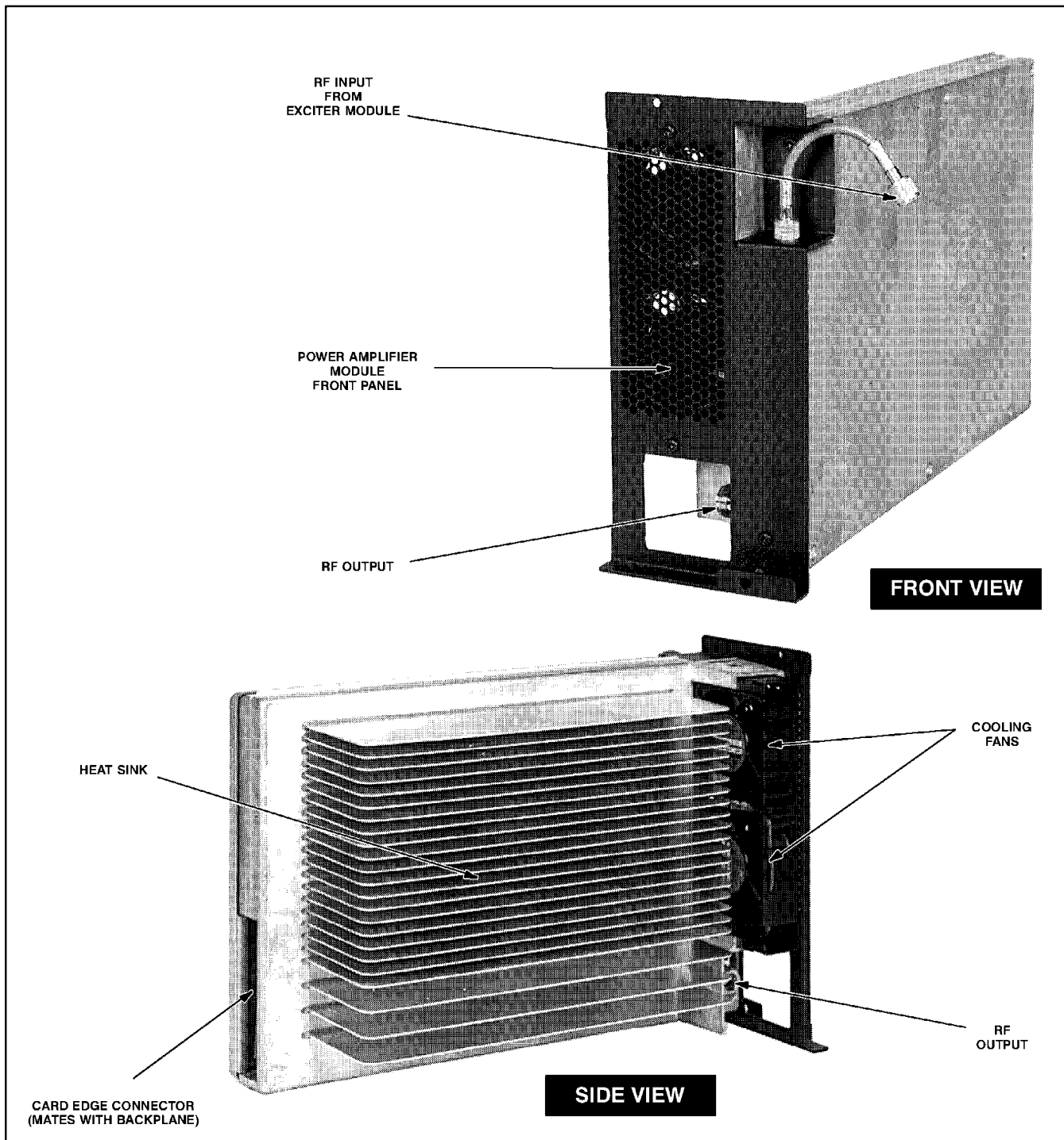

**Figure 1.** Power Amplifier Module Controls, Indicators, and Inputs/Outputs (100W Model Shown)

## 3

**FUNCTIONAL THEORY OF OPERATION**

The following theory of operation describes the operation of the PA circuitry at a functional level. The information is presented to give the service technician a basic understanding of the functions performed by the module in order to facilitate maintenance and troubleshooting to the module level. Functional block diagrams are provided in Figure 2 (TLF1940A, 20 W) and Figure 3 (TLF1800A and TLF1930A, 100 W). As mentioned previously, the four PA modules are similar in design and function. The following theory of operation applies to all four modules except where noted.

**RF Signal Path**

A low-level modulated rf signal (approximately +13 dBm) from the Exciter module is input to the PA module via a coax cable. The signal is input to the IPA and amplified to approximately 0 to 10W [depending on the dc power control voltage (V\_CONT) from the Exciter Module].

On the 20W model, the IPA output is fed to a DPA which provides final amplification. On the 100W model, the IPA output is fed to a DPA and then to an FPA which provides final amplification. The output of the DPA (35W maximum) or FPA (160W maximum) is fed to a circulator, which passes the transmit signal to the harmonic filter/coupler, while routing all reflected power to a 50Ω load.

The output of the circulator is fed to the harmonic filter/coupler. This circuit provides highly selective bandpass filtering and couples the signal to an N-type connector mounted to the module casting. A coax cable routes the signal to an N-type connector mounted on an rf input/output connector bracket located on the rear of the station.

**Output Power Control**

A feedback and control loop configuration is used to regulate the PA output power. The Harmonic Filter/Coupler generates a dc voltage proportional to the PA Module output power. This voltage (TX\_VF) is fed to the TX Power Control Circuitry in the Exciter Module. The TX\_VF voltage is compared to reference voltages to generate a dc power control voltage (V\_CONT).

Note that V\_OMNI does not control the output level of the DPA directly but serves as on/off control for the DPA stage.

The dc power control voltage (V\_CONT) is output from the Exciter Module and fed through filtering circuitry in the PA to a voltage translation and current limiting circuit. The output of this circuitry is V\_OMNI, a dc voltage which controls the output power of the IPA.

**Summary of Power Control Operation** — By controlling the output level of the IPA (range of 0 to 10W), the output power of the PA module is established. The feedback and control loop (TX\_VF fed back to Exciter Module resulting in V\_CONT to control IPA output) continually monitors and maintains the proper output power from the PA.

## Sense and Detect Circuitry

### **Introduction**

The PA is equipped with several sense and detect circuits to provide status signals to the Exciter Module. In most cases, the Exciter Module microprocessor uses these signals to determine PA operating conditions and, in response, varies certain control signals to correct output power, turn on cooling fans, etc. The sense and detect circuits are described in the following paragraphs.

### **Current Sensing Circuitry (20W)**

**IPA and DPA** current sense circuitry (comprised of two differential amplifiers and two sensing resistors) meters the current being drawn by the IPA and the DPA and outputs two dc signals directly proportional to the IPA and DPA currents. Circuit operation is described in the following paragraph.

In each of the current sense circuits, a differential amplifier measures the voltage drop across a sensing resistor and outputs a dc voltage directly proportional to the current through the resistor. The dc voltage (IPA\_I or DPA\_I) is fed to the Exciter Module (via an analog multiplexer and filtering circuitry) where it is used in calculating the current being drawn by the IPA or DPA.

### **Current Sensing Circuitry (100W)**

**IPA and DPA** current sense circuitry (comprised of two differential amplifiers and two sensing resistors) meters the current being drawn by the IPA and the DPA and outputs two dc signals directly proportional to the IPA and DPA currents. Circuit operation is described in the following paragraph.

In each of the current sense circuits, a differential amplifier measures the voltage drop across a sensing resistor and outputs a dc voltage directly proportional to the current through the resistor. The dc voltage (IPA\_I or DPA\_I) is fed to the Exciter Module (via an analog multiplexer and filtering circuitry) where it is used in calculating the current being drawn by the IPA or DPA.

**FPA** current sense circuitry (comprised of two differential amplifiers and two sensing resistors) meters the current being drawn by the FPA (side A and side B) and outputs two dc signals directly proportional to the currents for side A and side B. Circuit operation is described in the following paragraph.

In each of the current sense circuits, a differential amplifier measures the voltage drop across a sensing resistor and outputs a dc voltage directly proportional to the current through the resistor. The dc voltages (FPA\_I1\_A and FPA\_I1\_B) is fed to the Exciter Module (via an analog multiplexer and filtering circuitry) where it is used in calculating the current being drawn by the FPA (side A or side B).



---

## Sense and Detect Circuitry (Continued)

### ***PA Temperature Sense***

A thermistor and buffer circuit provides a dc voltage proportional to the PA temperature. This signal (PA\_TEMP) is fed to the Exciter Module, which monitors the signal and reduces the PA output power [by reducing the dc power control voltage (V\_CONT)] if the PA temperature exceeds set limits.

### ***IPA, DPA, and FPA Detect Circuitry***

Detection circuits provide a dc voltage approximately proportional to the rf outputs of the IPA, DPA, and FPA (100W only) stages. These dc signals (IPA\_VF, DPA\_VF, and FPA\_VF, used for diagnostic purposes only) are fed to the Exciter Module via an analog multiplexer and filter circuitry.

### ***Reflected Power Detect Circuitry***

The Harmonic Filter/Coupler provides a dc voltage approximately proportional to the reflected power at the output of the stage. This dc signal (TX\_VR) is fed to the Exciter Module via an analog multiplexer and filter circuitry. The signal indicates the amount of potentially harmful reflected power at the PA output. If the reflected power exceeds a set limit, the Exciter Module will shut down the PA.

### ***V\_OMNI Detect Circuitry***

A voltage divider circuit provides a dc voltage approximately proportional to the V\_OMNI control voltage from the Voltage Translator & Current Limiter circuit. This dc signal (V\_OMNI\*) is fed to the Exciter Module via an analog multiplexer and filter circuitry.

### ***+14V Detect Circuitry***

A voltage divider circuit provides a dc voltage approximately proportional to the +14 V dc input voltage from the station Power Supply Module. This dc signal (14.2V\_REF\*) is fed to the Exciter Module via an analog multiplexer and filter circuitry.

### ***+28V Detect Circuitry (100W Only)***

A voltage divider circuit provides a dc voltage approximately proportional to the +28 V dc input voltage from the station Power Supply Module. This dc signal (28V\_REF\*) is fed to the Exciter Module via an analog multiplexer and filter circuitry.

---

## Cooling Fans Control Circuitry (100 W Models Only)



The cooling fans in the PA Module are thermostatically controlled and may come on at any time during station operation. Keep fingers clear of fan blades.

The PA is equipped with a dual fan module to provide forced air cooling of the PA. The fan module is controlled by a FAN ON signal from the Exciter Module, which is fed to a driver circuit in the PA Module. The Fan Driver/Detect Circuitry controls the power to the fans via two feed-thru pins in the PA chassis which mate with the power connector on the slide-in fan module. The fans are turned on only when the temperature in the PA exceeds a set limit. It is normal for the fans to cycle on and off during station operation.

The Fan Driver/Detect Circuitry also monitors the current to the fans and feeds a dc detect voltage to the Fan Status Circuitry, which outputs a status signal indicating whether the fan current is above or below a predetermined range. The status signal (FAN\_ALARM) is fed to the Exciter Module via an analog multiplexer and filter circuitry.

---

## Power Amplifier ID Resistor ROM

A resistor network “ROM” provides power amplifier ID information to the Exciter Module via an analog multiplexer and filter circuits. This information includes the band and range in which the PA is designed to operate (e.g., VHF–Range 1, UHF, 900 MHz, etc.) and the maximum output power (e.g., 25 W, 125 W, etc.).

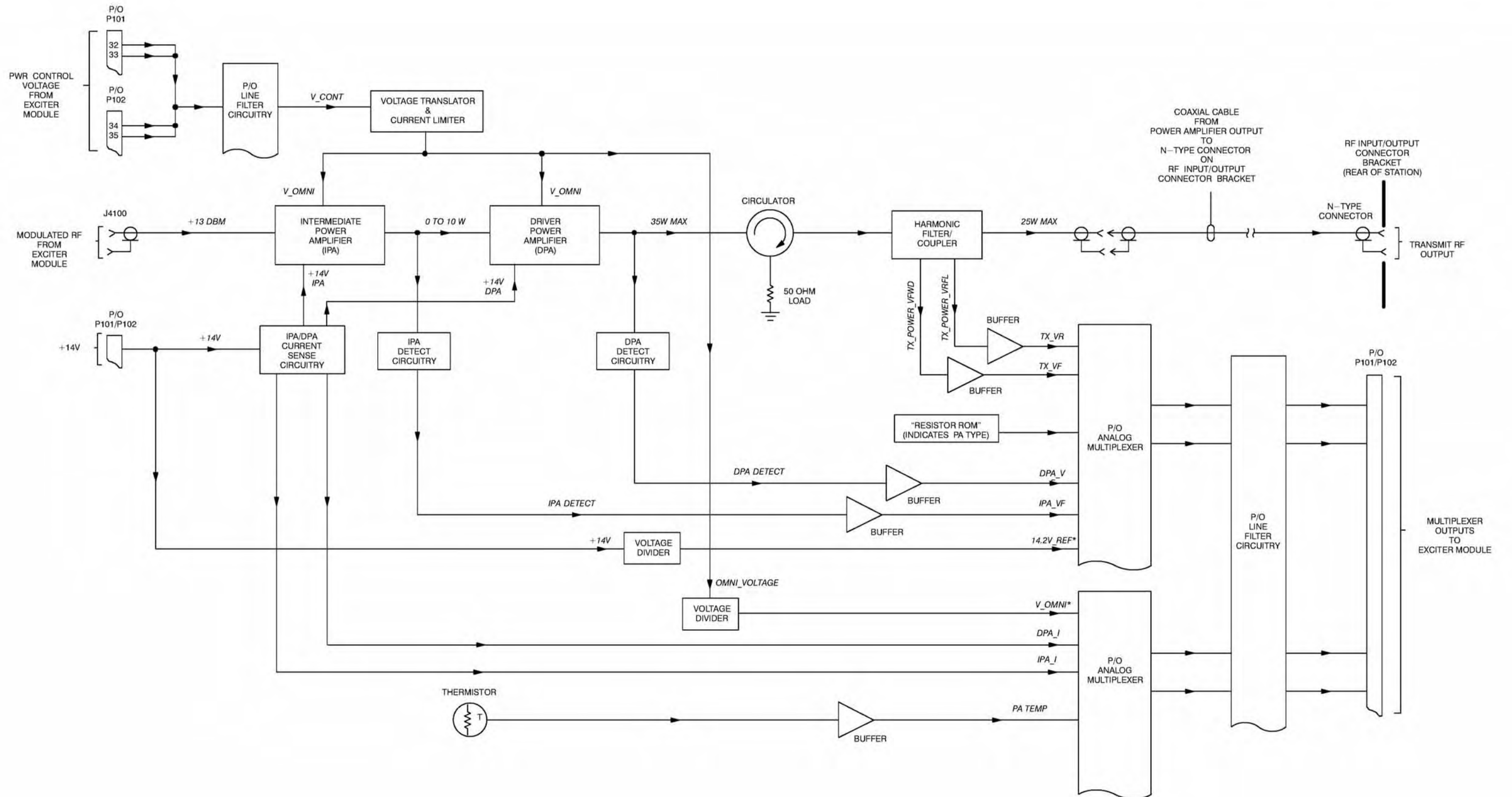

Figure 2. TLF1940A (800 MHz) 20W Power Amplifier Module Functional Block Diagram

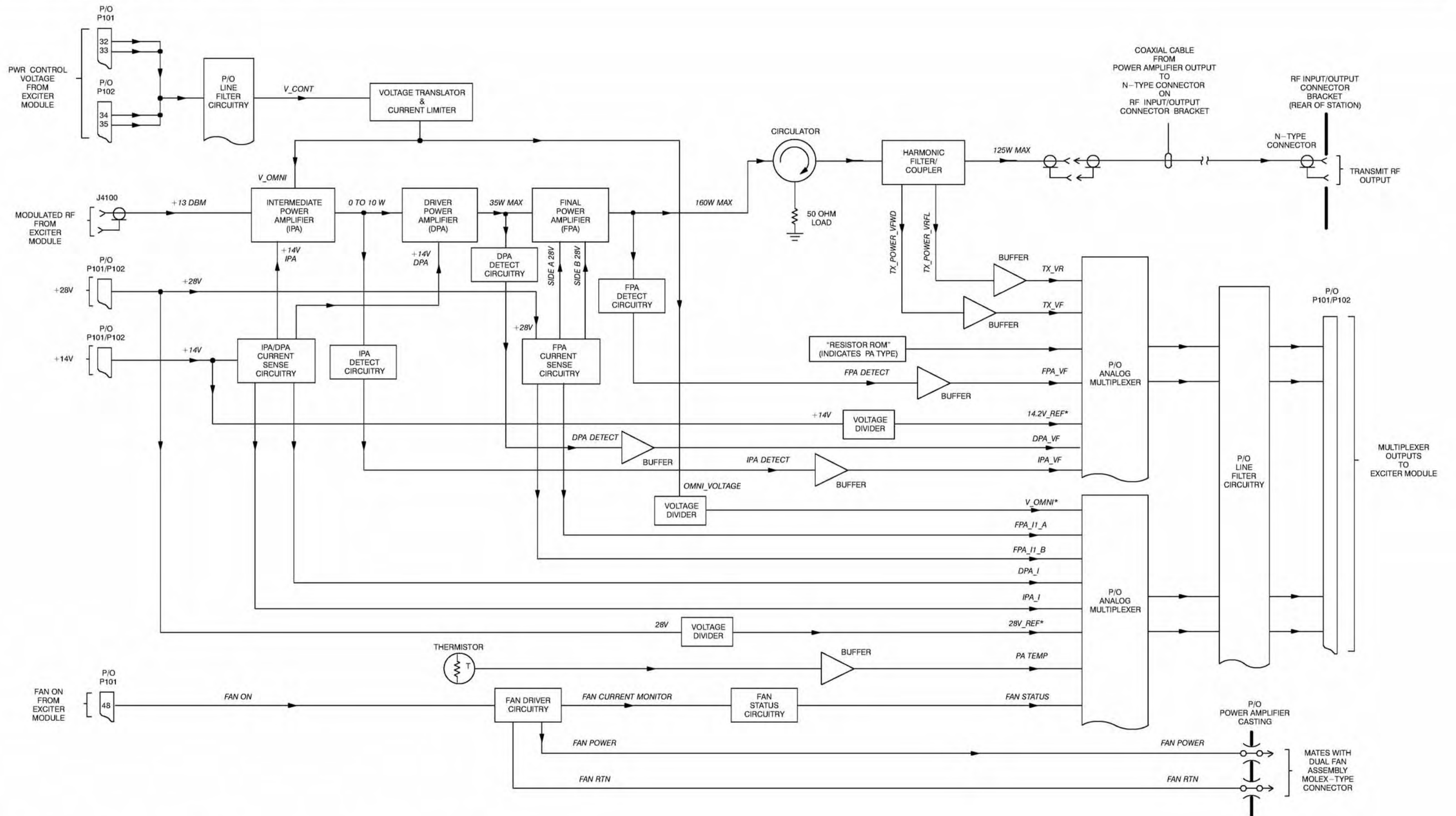

Figure 3. TLF1930A (800 MHz) and TLF1800A (900 MHz) 100W Power Amplifier Module Functional Block Diagram



# STATION CONTROL MODULE

MODELS CLN6960E  
CLN6961E  
CLN1614C

---

---

## 1 DESCRIPTION

The Models CLN6960E, CLN6961E, and CLN1614C station control modules (SCM) are described in this section. A general description, identification of controls, indicators, and inputs/outputs, a functional block diagram, and functional theory of operation are provided. The information provided is sufficient to give service personnel a functional understanding of the module, allowing maintenance and troubleshooting to the module level. (Refer also to the *Maintenance and Troubleshooting* section of this manual for detailed troubleshooting procedures for all modules in the station.)

---

### General Description

The SCM serves as the main controller for the station. The SCM board contains a 68EN360 microprocessor, a 56002 digital signal processor (DSP), and support circuitry which combine to provide signal processing and operational control over the other station modules. The SCM also contains the station operating software (stored in FLASH memory) and codeplug which define the personality of the station, including system capabilities (ASTRO, IntelliRepeater, etc.) and operating parameters such as output power and operating frequency.

The CLN6961 and CLN1614 provide conventional operation along with MRTI and 6809 trunking capabilities. The CLN6960 is a full-featured model and is required for use in IntelliRepeater applications. Specific differences between the models are shown throughout the functional block diagram (Figure 2).

---

### Overview of Circuitry

The SCM contains the following circuitry:

- **Host Microprocessor** ( $\mu\text{P}$ )— The 68EN360  $\mu\text{P}$  is the central controller of the SCM and station
- **Non-Volatile Memory** — consists of a FLASH SIMM module that contains the station operating software and data, and an EEPROM that contains the station codeplug data
- **DRAM Memory** — Dynamic RAM into which station software is downloaded and executed

- **External Line Interface Circuitry** — provides interface between the SCM and external devices such as IntelliRepeater DLAN ports, RSS port, an Ethernet port, and miscellaneous backplane connectors
- **Digital Signal Processor (DSP) and DSP ASIC Circuitry** — performs high-speed processing of audio and signaling data signals
- **Station Reference Circuitry** — generates the 2.1 MHz reference signal used throughout the station
- **HDLC Bus Control Circuitry** — provides bus control to allow host communications port SCC1 to communicate with the wireline interface board (WIB) and other optional modules via the HDLC interprocessor communications bus
- **Audio Interface Circuitry** — routes the various audio input signals (such as microphone, wireline, and receiver audio) to output devices (such as external speaker, built-in local speaker, and exciter modulation inputs)
- **Input/Output Ports Circuitry** — two 32-line output buses allow miscellaneous control signals to be sent to various circuits throughout the station; two 32-line input buses allow miscellaneous inputs to be received from throughout the station
- **Front Panel LEDs and Switches** — general purpose input/output ports control eight status LEDs and accept inputs from four momentary switches, all located on the SCM front panel
- **Supply Voltage Circuitry** — contains filtering and regulator circuitry which accepts +14.2 V and +5 V from backplane and generates the operating voltages required by the SCM circuitry

## 2 CONTROLS, INDICATORS, AND INPUTS/OUTPUTS

Figure 1 shows the SCM controls, indicators, and all input and output external connections.

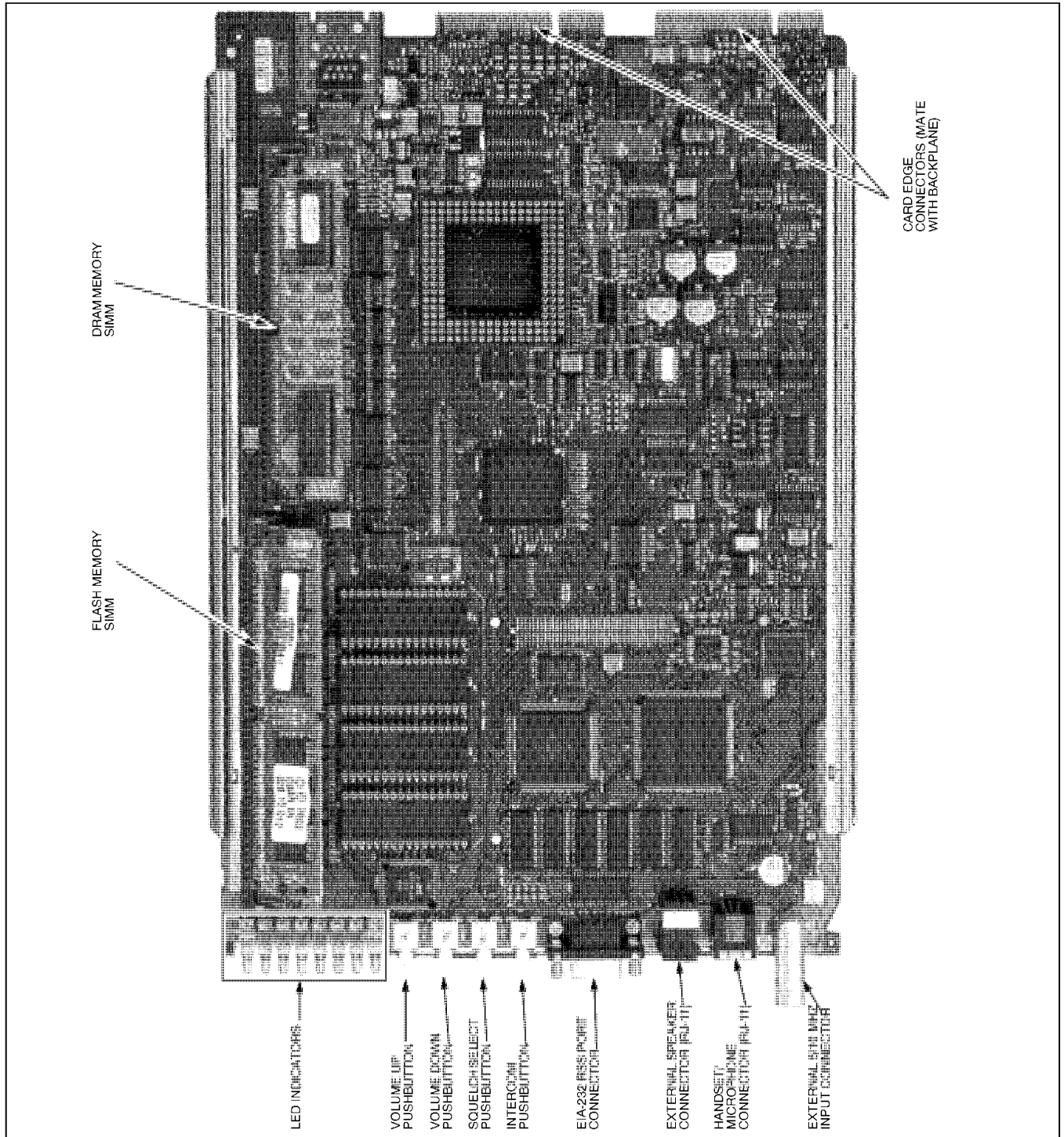

**Figure 1** Station Control Module Controls, Indicators, and Inputs/Outputs (CLN6960E shown)

## 3 FUNCTIONAL THEORY OF OPERATION

The following theory of operation describes the operation of the SCM circuitry at a functional level. The information is presented to give the service technician a basic understanding of the functions performed by the module in order to facilitate maintenance and troubleshooting to the module level. Refer to Figure 2 for a block diagram of the SCM.

---

### Host Microprocessor

#### *Overview*

The host  $\mu$ P serves as the main controller for the SCM (and station). The host  $\mu$ P, an MC68EN360 running at a clock speed of 25 MHz, controls the operation of the station as determined by the station software (contained in a FLASH SIMM module) and the station codeplug (EEPROM).

#### *Communications Buses*

The host  $\mu$ P provides six general-purpose serial communications buses, as follows:

- **SCC1** — Used as Ethernet port for high-speed communications, either to connect to the Ethernet local network of an IntelliRepeater trunking site or to allow station software to be downloaded from a local PC into the FLASH memory
- **SCC2** — Used as communications port to allow the station to connect into the local network of an IntelliRepeater trunking site; external connections are provided by a 9-pin D-type connector (#19) located on backplane
- **SCC3** — Used as the interprocessor communications bus (HDLC protocol) to allow the host  $\mu$ P to communicate with the WIB and other optional modules
- **SCC4** — Used as RS-232 port for connections to external equipment, such as a modem
- **SMC1** — Used as RS-232 port for RSS communications (9-pin D-type connector #20 on backplane)
- **SMC2** — Used as RS-232 port for RSS communications (9-pin D-type connector located on SCM front panel)

#### *Address and Data Buses*

The  $\mu$ P is equipped with a 28-line address bus used to access the non-volatile memory, DRAM memory, and provide control (via memory mapping) for other circuitry in the SCM. A 32-line data bus (buffered for the non-volatile memory) is used to transfer data to/from the SCM memory, as well as other SCM circuitry.

#### *SPI Bus*

The host  $\mu$ P also controls the SPI bus, a general-purpose communications bus that allows the host  $\mu$ P to communicate with other modules in the station.



**DRAM Controller**

The host  $\mu$ P provides signals necessary to access and refresh the DRAM memory.

**25 MHz Clock Circuitry**

A crystal-controlled 25 MHz clock circuit and buffer provide the 25 MHz clock signal to the host  $\mu$ P.

---

**Non-Volatile Memory****Station Software FLASH Memory**

The station software resides in a FLASH SIMM module (1M x 32 for CLN6960E, 512k x 32 for CLN6961E and CLN1614C). The FLASH SIMM is accessed by the host  $\mu$ P via the 28-line host buffered address bus and the 32-line host buffered data bus.

**Codeplug EEPROM**

The data which determines the station personality resides in an 8K x 8 codeplug EEPROM. Stations are shipped from the factory with generic default data programmed into the codeplug EEPROM. Field programming is performed during installation using the Radio Service Software (RSS) program to enter additional customer-specific data, such as site output power, time-out timer settings, etc.

---

**DRAM Memory**

Each SCM contains a 2MX32 DRAM SIMM into which the station software code is downloaded and run. The DRAM also provides short-term storage for data generated/required during normal operation. Read and write operations are performed using the host buffered address and host buffered data buses.

The DRAM memory locations are sequentially refreshed by the column and row signals from the host  $\mu$ P.

---

**External Line Interface Circuitry****IntelliRepeater DLAN Network Port**

A DLAN port is provided on the station backplane to allow the station to connect into the local network of an IntelliRepeater trunking site. This DLAN port is provided by host  $\mu$ P serial communication bus SCC2.

SCC2 communicates with an RS-485 bus transceiver, which provides DLAN+ and DLAN- signals. These signals are connected to a 9-pin D-type connector (#19) located on the station backplane, which typically mates with a PhoneNET adapter module connected into the IntelliRepeater local network.

### ***Ethernet Port***

An Ethernet port is provided via a BNC connector on the station backplane which allows the station to connect into the Ethernet local network of an IntelliRepeater trunking site. The Ethernet port may also be used to allow station software to be downloaded from a local PC into the FLASH SIMM module. This Ethernet port is provided by host  $\mu$ P serial communication bus SCC1.

### ***General Purpose RS232 Serial Port***

A general purpose RS-232 communications port is provided by host  $\mu$ P serial communication bus SCC4. This port is available at a DB-25 connector (#15) located on the station backplane, and may be used to connect external equipment such as an external modem.

### ***RSS Port (Backplane)***

A 9-pin D-type connector (#20) is provided on the station backplane to allow service personnel to connect a PC loaded with the Radio Service Software (RSS) and perform programming and maintenance tasks. The RSS port may also be used to allow station software to be downloaded from a local PC into the FLASH SIMM module. This RSS port is provided by host  $\mu$ P serial communication bus SMC1 which communicates with the RSS terminal via EIA-232 Bus Receivers/Drivers.

### ***RSS Port (Front Panel)***

A 9-pin D-type connector is provided on the SCM front panel to allow service personnel to connect a PC loaded with the Radio Service Software (RSS) and perform programming and maintenance tasks. The RSS port may also be used to allow station software to be downloaded from a local PC into the FLASH SIMM module. This RSS port is provided by host  $\mu$ P serial communication bus SMC2 which communicates with the RSS terminal via EIA-232 Bus Receivers/Drivers.

---

## **Digital Signal Processor (DSP) and DSP ASIC Circuitry**

### ***General***

All station transmit and receive audio/data is processed by the DSP and related circuitry. This circuitry includes the DSP IC, the DSP ASIC, and the DSP ASIC interface circuitry. All audio signals in to and out of the DSP are in digitized format.

**Inputs** to the DSP circuitry are:

- Digitized receive signals from the receiver module
- Audio from handset or microphone connected to appropriate SCM front panel connector; signal is digitized by CODEC IC (p/o audio interface circuitry) before being sent to DSP via audio interface bus
- Digitized voice audio/data from WIB and other optional modules via TDM bus

- ASTRO modem data from WIB via HDLC bus
- 6809/MRTI transmit audio

**Outputs** from the DSP circuitry are:

- Digitized voice audio/data from DSP to WIB and other optional modules via TDM bus
- Digitized voice audio from DSP to external speaker, built-in speaker, or handset earpiece via audio interface bus and audio interface circuitry
- Digitized voice audio/data from DSP to exciter module (modulation signals) via audio interface bus and audio interface circuitry
- 6809/MRTI transmit audio

### **Digital Signal Processor (DSP)**

The DSP, a 56002 operating at an internal clock speed of 60 MHz, accepts and transmits digitized audio to/from the various modules in the station. The DSP provides address and data buses to receive/transmit digitized audio (via the DSP ASIC) and to access the DSP program and signal processing algorithms contained in three 32K x 8 SRAM ICs.

Three additional 32K x 8 SRAM ICs are provided for data storage.

### **DSP ASIC**

The DSP ASIC operates under control of the DSP to provide a number of functions, as follows:

- Interfaces with the DSP via the DSP address and data buses
- Accepts 16.8 MHz signal from Station Reference Circuitry and outputs a 2.1 MHz reference signal used throughout the station
- Provides interfaces for the HDLC bus, TDM bus, and serial bus used to communicate with the Receiver Module
- Accepts digitized data from Receiver Module via DSP ASIC Interface Circuitry
- Provides interfaces for several A/D and D/A converters

---

## **Station Reference Circuitry**

**Note:** Two BNC connectors (one 50  $\Omega$  input located on SCM front panel, one high impedance input located on the station backplane) are provided to allow an external 5/10 MHz source to be connected to the  $OSC_{in}$  input to the PLL to perform frequency netting. Refer to the Maintenance section in this manual for recommended intervals and procedures for netting the station reference.

The station reference circuitry consists of a phase-locked loop (PLL) comprised of a high-stability VCO and a PLL IC. The output of the VCO is a 16.8 MHz signal which is fed to the DSP ASIC. The ASIC divides the signal by 8 and outputs a 2.1 MHz signal which is separated and buffered by a splitter and output to the Exciter Module and Receiver Module as 2.1 MHz REF.

The Station Reference Circuitry may operate in one of three modes:

- **Normal Mode** — In this mode, the control voltage is turned off (via control voltage enable switch) and the high-stability VCO operates in an open loop mode; stability of the VCO in this mode is 1 PPM per year.

- **Manual Netting Mode** — Periodically, an external 5/10 MHz source is required to fine tune, or “net”, the 16.8 MHz reference signal. In this mode, the PLL compares the 5/10 MHz reference and a sample of the 16.8 MHz VCO output and generates up/down pulses. The host  $\mu$ P reads the pulses (via SPI bus) and sends correction signals (via SPI bus) to the VCO to adjust the output frequency to 16.8 Mhz  $\pm 0.3$  ppm.
- **High-Stability Mode** — For some systems, such as simulcast systems, the free-running stability of the VCO is unacceptable for optimum system performance. Therefore, an external 5/10 MHz source is connected permanently to one of the BNC connectors. In this mode, the PLL compares the 5/10 MHz reference and a sample of the 16.8 MHz VCO output and generates a dc correction voltage. The control voltage enable switch is closed, allowing the control voltage from the PLL to adjust the high-stability VCO frequency to 16.8 MHz  $\pm 0.3$  ppm. The VCO operates in this closed loop mode and is continually being frequency controlled by the control voltage from the PLL.

---

## HDLC Bus Control Circuitry

The HDLC bus control circuitry provides high-impedance buffering and data routing for the interprocessor communications bus (a serial data bus implementing HDLC protocol). This bus allows the host  $\mu$ P to communicate with the host  $\mu$ P located on the WIB and other optional modules via an interprocessor communications bus.

---

## Audio Interface Circuitry

### *General*

The audio interface circuitry interfaces external analog audio inputs and outputs with the DSP circuitry.

### *External Audio Sources*

A multiplexer, under control of the host  $\mu$ P, is used to select one of eight possible external audio input sources (four for diagnostic loopback signals, two for future use, one for 6809/MRTI transmit audio, and one for handset or microphone audio). The selected audio source signal is converted to a digital signal by the A/D portion of the CODEC IC and sent to the DSP ASIC via the audio interface bus. The DSP circuitry processes the signal and routes it to the desired destination.

### *External Audio Destinations*

Digitized audio from the DSP circuitry is applied to the D/A portion of the CODEC IC and is then sent to one of four external devices:

- External Speaker — connects to RJ-11 jack ( | | ) located on SCM front panel
- Handset Earpiece/Microphone — connects to RJ-11 jack ( ) located on SCM front panel

- Local Built-In Speaker — internal speaker and ½ W audio amplifier; may be switched on/off and volume controlled by using volume up ( ) and down ( ) buttons on SCM front panel
- J14 on Station Backplane — 6809/MRTI receive audio output to external MRTI Module

### ***Exciter Modulation Signals***

Digitized audio/data intended to be transmitted from the station is sent from the DSP circuitry to a D/A converter via the TX/Voice Audio signal (part of the serial synchronous interface bus, connected between the DSP and the DSP ASIC). The digitized signal is converted to analog, level shifted and amplified, and fed to a 0-6 kHz filter. The output of the filter is then fed to one of the inputs of a multiplexer. The output of the multiplexer is fed to two individual digitally controlled potentiometers (each of which is adjusted by the host  $\mu$ P via the SPI Bus) and applied to the exciter module as modulation signals VCO MOD AUDIO and REF MOD AUDIO.

---

## **Input/Output Ports**

### ***Input Ports***

Two general-purpose 32-line input ports are provided to allow various input signals from the SCM and station circuitry to be accepted and sent to the host  $\mu$ P. The two ports (I/O Port P0 In and I/O Port P1 In) are each comprised of 32 lines which come from circuitry in the SCM as well as other modules in the station via the backplane. The buses are received by buffers which make the data available to the host  $\mu$ P via the host buffered data bus. Typical inputs include the pushbutton switches located on the SCM front panel and the MIC PTT signal from the handset/microphone.

### ***Output Ports***

Two general-purpose 32-line output ports are provided to allow various control signals from the host  $\mu$ P to be output to the SCM and station circuitry via the backplane. The two ports (I/O Port P0 Out and I/O Port P1 Out) are each comprised of 32 lines which come from the host buffered data bus via latches. Typical output control signals include the control lines for the eight LEDs located on the SCM front panel and the local speaker enable signal.

---

## **6809/MRTI Interface Circuitry**

### ***6809 Trunking Interface***

TX DATA from the 6809 trunking controller is received by the station via J14 on the station backplane. The signal is routed through nominal filtering on the 6809/MRTI interface circuitry and fed to the audio interface circuitry. The T DATA signal is then waveshaped/filtered and fed to an A/D converter, which outputs a digital signal to the DSP via the audio interface bus.

6809 RX AUDIO is output from the DSP to the local audio circuitry via the audio interface bus. The signal is amplified, filtered, buffered, and output through nominal filtering on the 6809/MRTI interface circuitry to the 6809 trunking controller via J14 on the station backplane.

#### **MRTI Interface**

MRTI AUDIO from an external MRTI module is received by the station via J14 on the station backplane. The signal is routed through the 6809/MRTI interface circuitry and fed to one input of an 8-to-1 multiplexer. If selected, the MRTI TX AUDIO signal is converted to a digital signal by the A/D portion of the CODEC IC and sent to the DSP ASIC via the audio interface bus.

MRTI RX AUDIO is output from the DSP to the local audio circuitry via the audio interface bus. The signal is amplified, filtered, buffered, and output through the 6809/MRTI interface circuitry to the external MRTI module via J14 on the station backplane.

---

## **Front Panel LEDs and Switches**

**Note:** Refer to the Troubleshooting section of this manual for complete details on the interpretation of the LEDs.

**Note:** Refer to the Operation section of this manual for complete details on the use of the pushbutton switches.

#### **LEDs**

Eight status LEDs on the SCM front panel provide visual indications of various station operating conditions. The LEDs are controlled by eight lines from I/O Port P0 Out.

#### **Switches**

Four momentary contact pushbutton switches are provided on the SCM front panel to allow various station functions to be selected. Pressing a pushbutton causes a high to be sent to the host  $\mu$ P via I/O Port P0 In.

---

## **Supply Voltages Circuitry**

The SCM contains on-board regulator and filtering circuitry to generate the various operating voltages required by the SCM circuitry. +14.2 V and +5V from the backplane are used as sources for the following supply voltage circuits:

- **+10V Regulator Circuitry** — provides +10 V dc and a +5 V reference voltage ( $\frac{1}{2}$  of +10V) for the audio interface circuitry in the SCM.
- **VCCA Supply Circuitry** — provides VCCA (+5V) and a +2.5 V reference voltage ( $\frac{1}{2}$  of VCCA) for the audio interface circuitry in the SCM.
- **Filtering Circuitry** — filters the +14.2 V and +5V from the backplane to provide A+ and VCC, respectively, for the SCM digital circuitry.

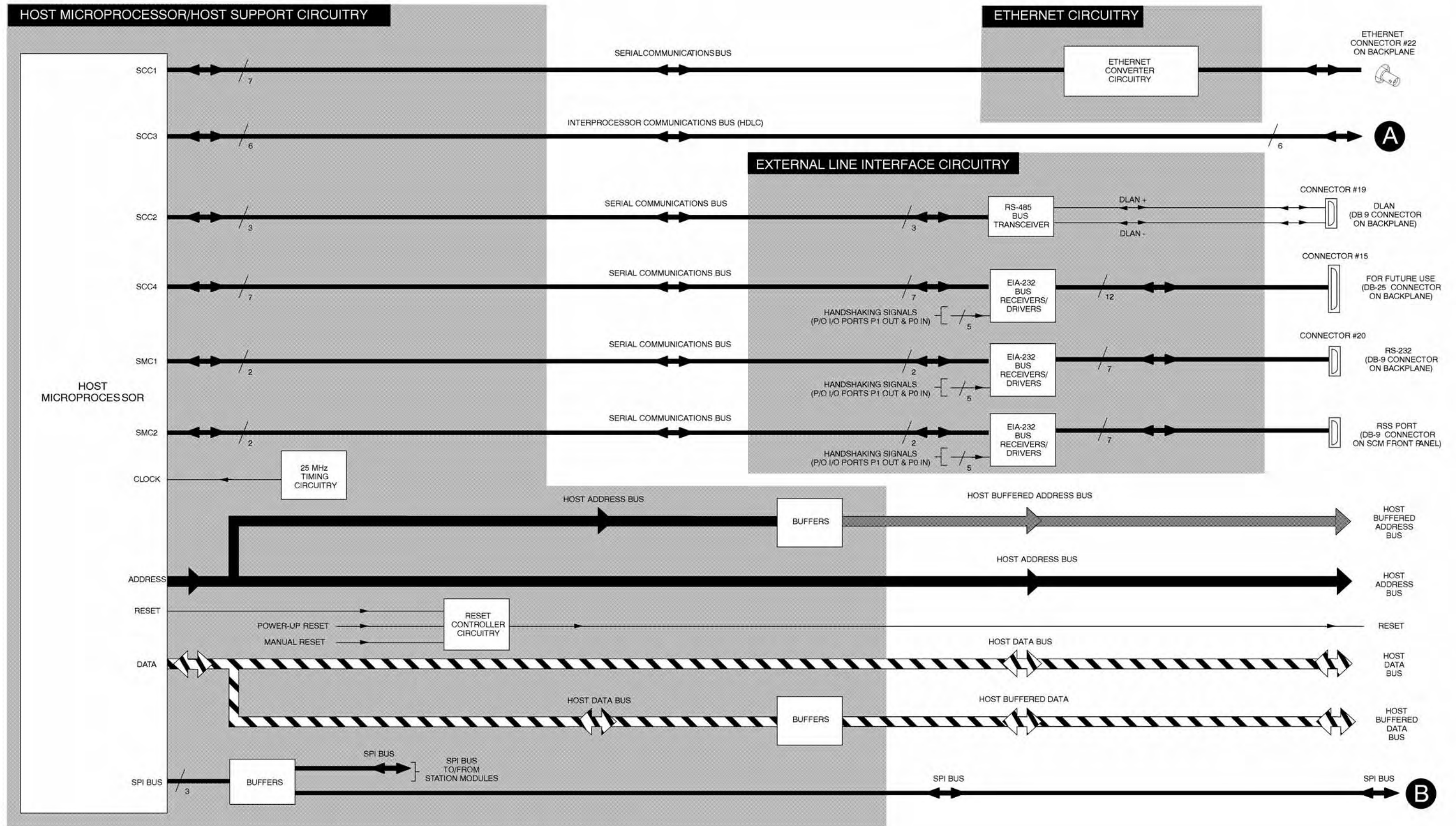

Figure 2 CLN6960E, CLN6961E, and CLN1614C Station Control Module Functional Block Diagram (1 of 5)

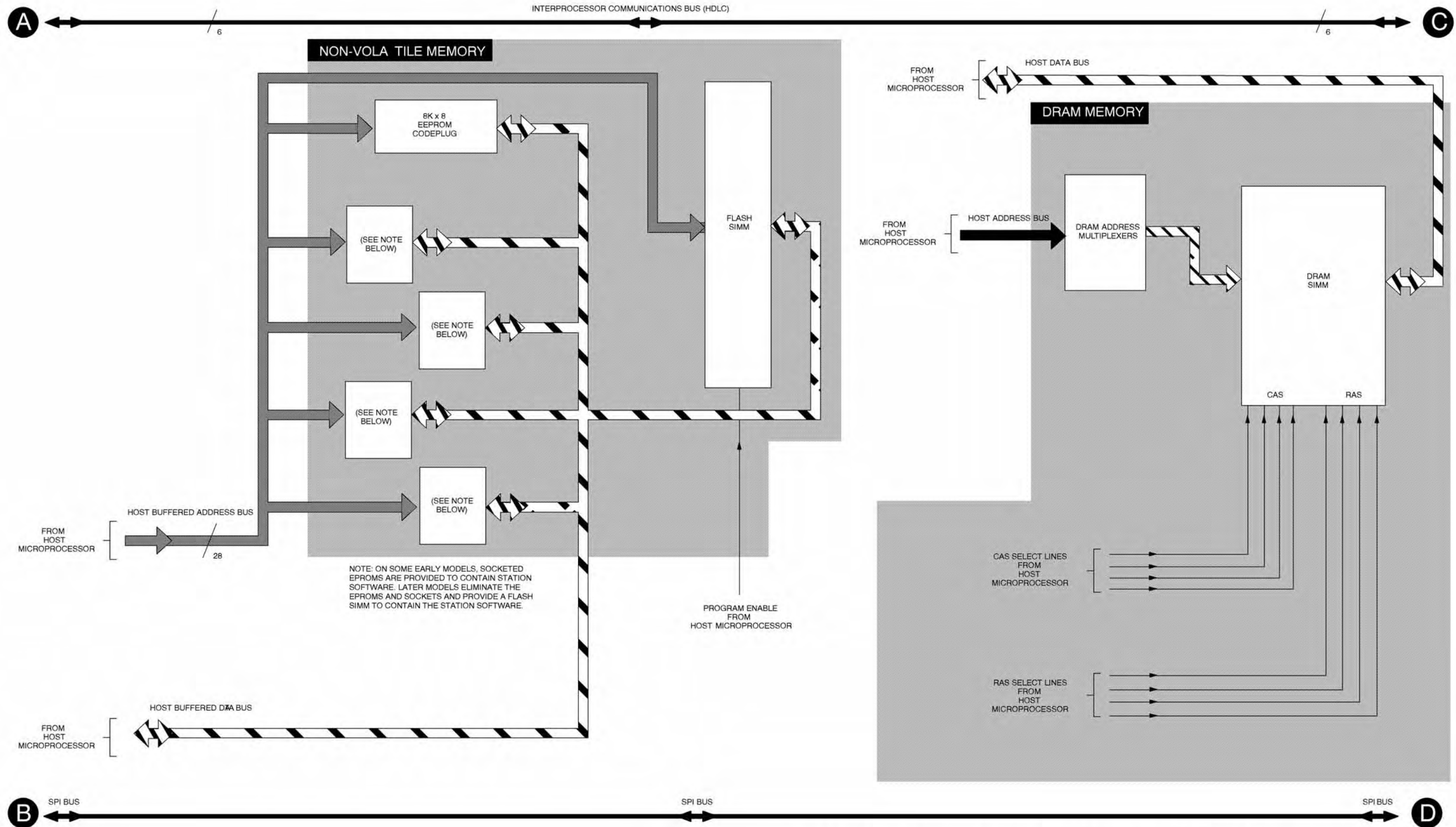

Figure 2 CLN6960E, CLN6961E, and CLN1614C Station Control Module Functional Block Diagram (2 of 5)



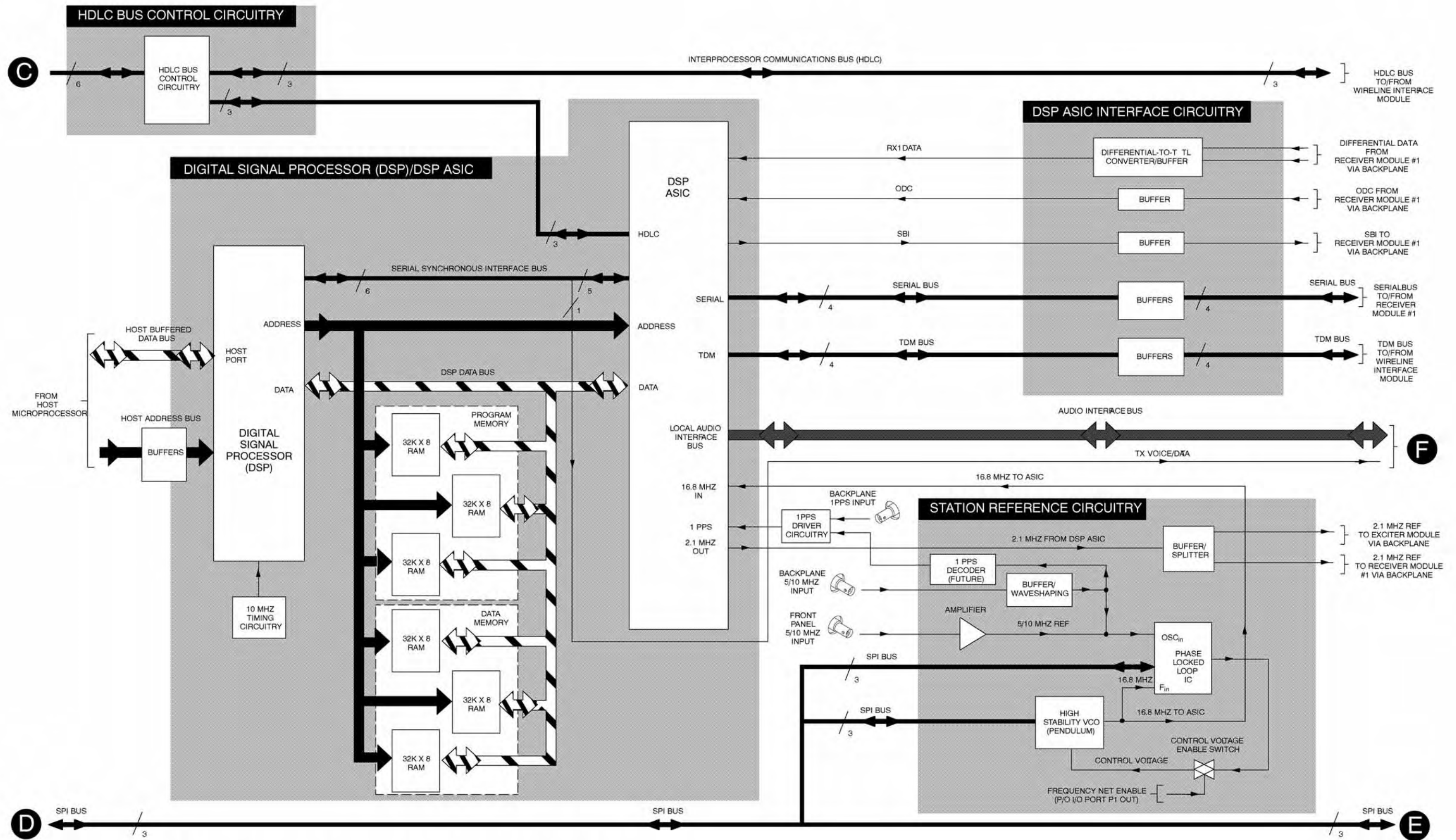

Figure 2 CLN6960E, CLN6961E, and CLN1614C Station Control Module Functional Block Diagram (3 of 5)

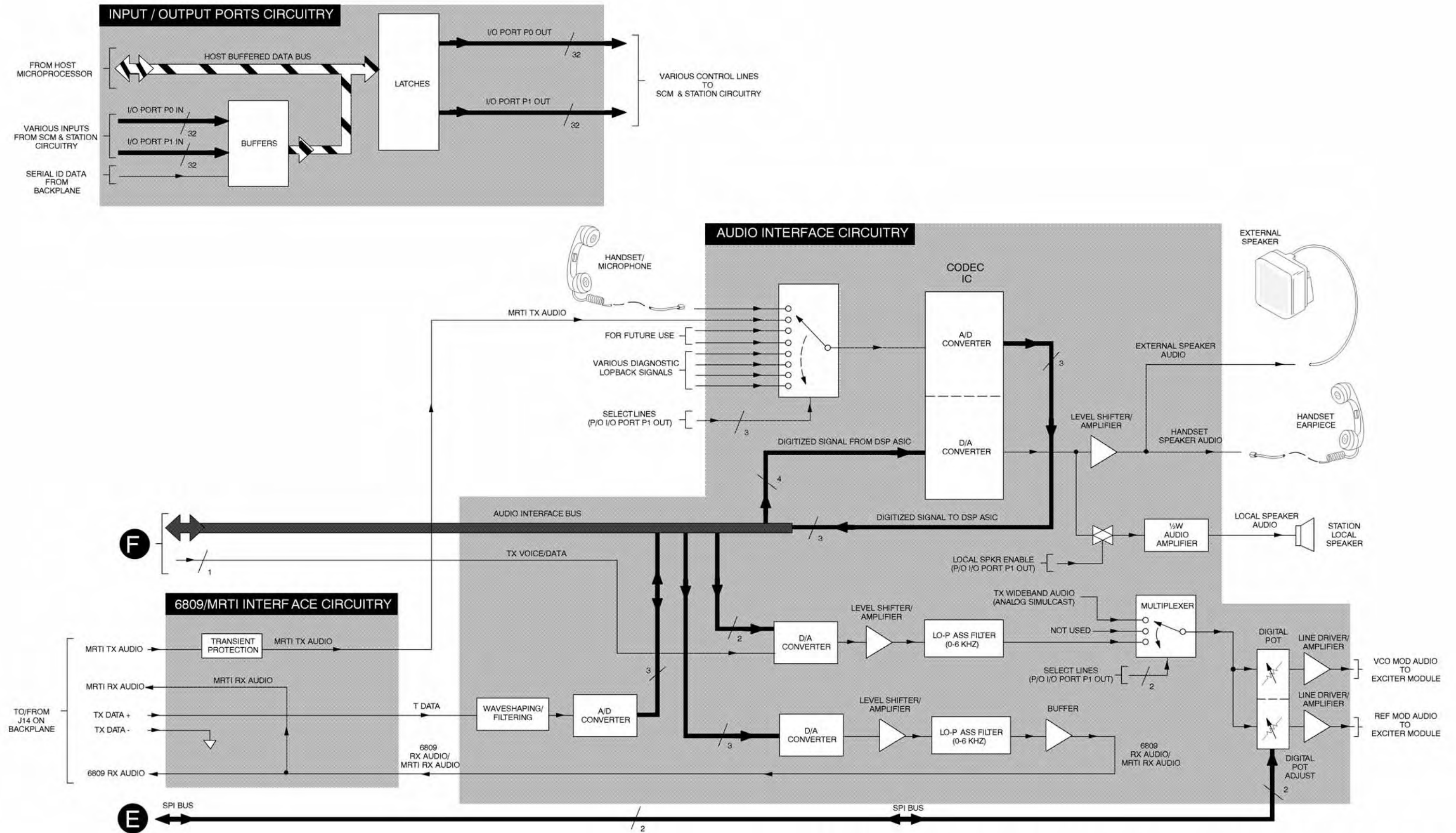

Figure 2 CLN6960E, CLN6961E, and CLN1614C Station Control Module Functional Block Diagram (4 of 5)

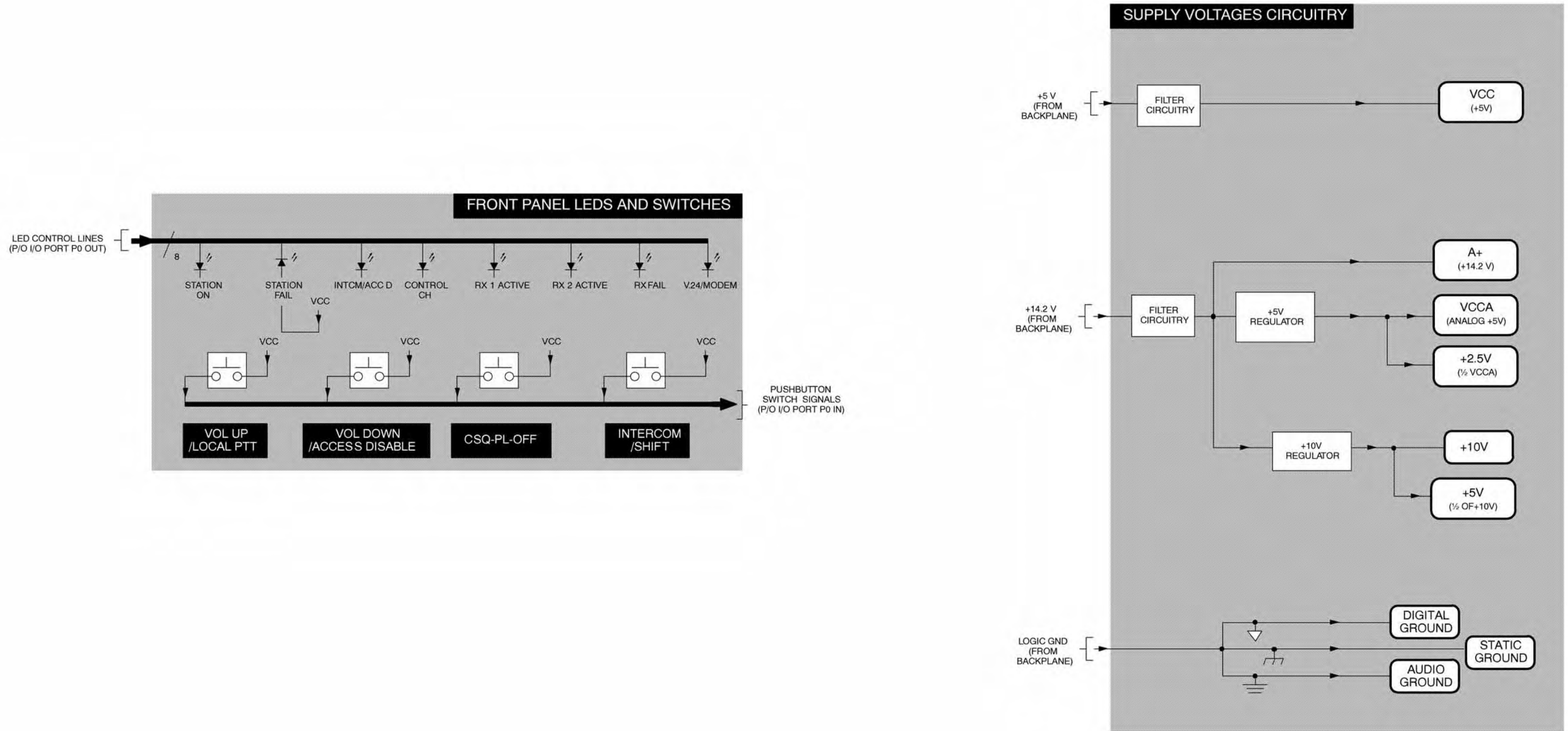

Figure 2 CLN6960E, CLN6961E, and CLN1614C Station Control Module Functional Block Diagram (5 of 5)



# STATION CONTROL MODULE

MODELS CLN1614A  
CLN1614B

## 1 DESCRIPTION

The Model CLN1614A and CLN1614B Station Control Module (SCM) is described in this section. A general description, identification of controls, indicators, and inputs/outputs, a functional block diagram, and functional theory of operation are provided. The information provided is sufficient to give service personnel a functional understanding of the module, allowing maintenance and troubleshooting to the module level. (Refer also to the Maintenance and Troubleshooting section of this manual for detailed troubleshooting procedures for all modules in the station.)

### General Description

The SCM serves as the main controller for the station. Each SCM is comprised of two circuit boards (Control Board and LED Board), contained in a single slide-in housing. The two boards are connected via a multi-conductor ribbon cable.

The Control Board contains a 68EN360 microprocessor, a 56002 Digital Signal Processor, and support circuitry which combine to provide signal processing and operational control over the other station modules. The SCM also contains the station operating software (stored in FLASH memory) and codeplug which define the personality of the station, including system capabilities (*ASTRO*, *SECURENET*, etc.) and operating parameters such as output power and operating frequency.

The CLN1614A/B SCM provides conventional operation along with MRTI and 6809 trunking capabilities for use in *Quantar* and *Quantro* stations.

**Note:** *The CLN1614A uses tantalum capacitors and the CLN1614B uses ceramic capacitors. Otherwise, the two models are identical.*

## Overview of Circuitry

The SCM is comprised of two circuit boards, connected together via a multi-conductor ribbon cable. These boards contain circuitry as follows:

### **Control Board (CLN7060A)**

- **Host Microprocessor** — 68EN360  $\mu$ P which comprises the central controller of the SCM and station
- **Non-Volatile Memory** — consists of a FLASH SIMM module that contains the station operating software and data, and an EEPROM that contains the station codeplug data
- **DRAM Memory** — Dynamic RAM into which station software is downloaded and executed
- **External Line Interface Circuitry** — provides interface between the SCM and external devices such as the RSS port, an Ethernet port, and miscellaneous backplane connectors
- **Digital Signal Processor (DSP) and DSP ASIC Circuitry**— performs high-speed processing of audio and signaling data signals
- **Station Reference Circuitry** — generates the 2.1 MHz reference signal used throughout the station
- **HDLC Bus Control Circuitry** — provides bus control to allow Host Microprocessor communications port SCC1 to communicate with the Wireline Interface Board and other optional modules via the HDLC interprocessor communications bus
- **Audio Interface Circuitry** — Comprised of a Local Audio ASIC that routes the various audio input signals (such as microphone, wireline, and receiver audio) to output devices (such as external speaker, built-in local speaker, and exciter modulation inputs)
- **Input / Output Ports Circuitry** — two multi-line output buses allow miscellaneous control signals to be sent to various circuits throughout the station; two multi-line input buses allow miscellaneous inputs to be received from throughout the station
- **Supply Voltages Circuitry** — contains filtering and regulator circuitry which accepts +14.2 V and +5 V from backplane and generates the operating voltages required by the SCM circuitry

### **LED Board (CLN7098A)**

- **Front Panel LEDs and Switches** — general purpose input/output ports control eight status LEDs and accept inputs from four momentary switches, all located on the SCM front panel
- **Front Panel Connectors** — four connectors (RSS Port DB-9, External Speaker RJ-11, Handset/Microphone RJ-11, and 5/10 MHz External Input BNC) are mounted on the front panel for interface with external equipment

## 2 CONTROLS, INDICATORS, AND INPUTS/OUTPUTS

Figure 1 and Figure 2 show the SCM controls, indicators, and all input and output external connections.

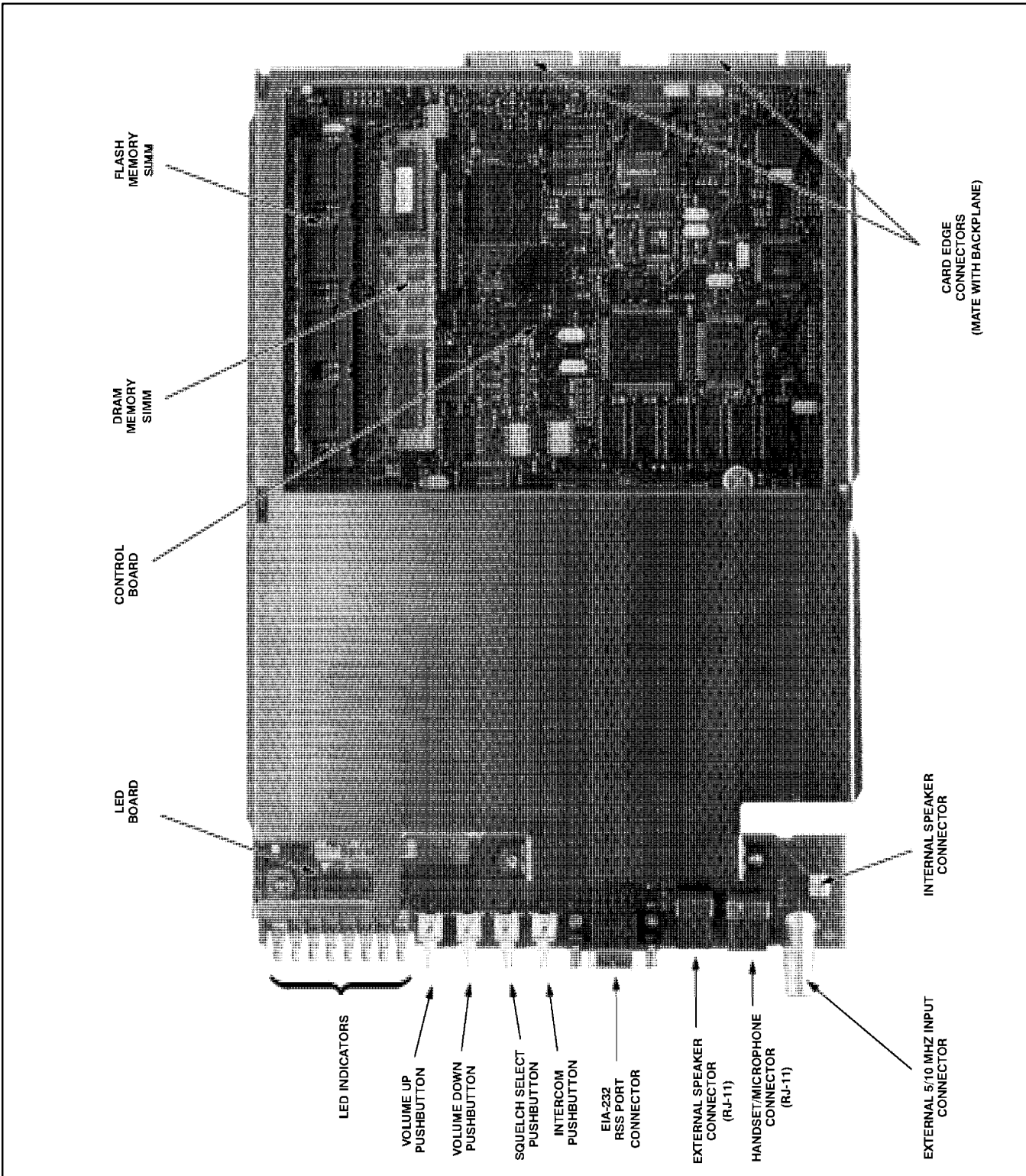
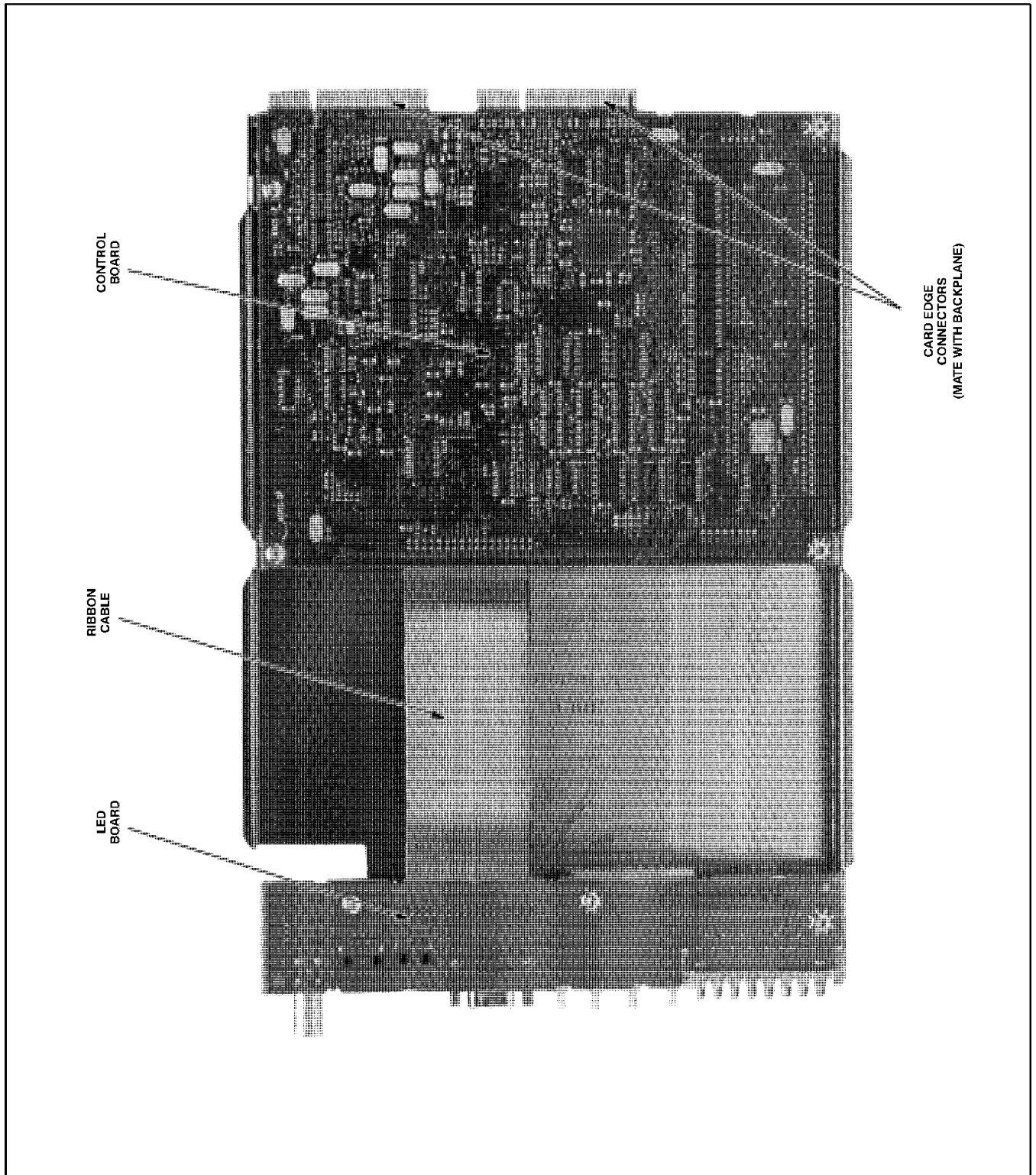

Figure 1. Station Control Module Controls, Indicators, and Inputs/Outputs (Front View)



**Figure 2.** Station Control Module Controls, Indicators, and Inputs/Outputs (Rear View)

### 3 FUNCTIONAL THEORY OF OPERATION (CLN7060A Control Board; Tantalum Capacitors) (CLN7558A Control Board; Ceramic Capacitors)

The following theory of operation describes the operation of the CLN7060A/CLN7558A Control Board circuitry at a functional level. The information is presented to give the service technician a basic understanding of the functions performed by the module in order to facilitate maintenance and troubleshooting to the module level. Refer to Figure 3 for a block diagram of the CLN7060A/CLN7558A Control Board.

#### Host Microprocessor

##### Overview

The Host Microprocessor ( $\mu$ P) serves as the main controller for the SCM (and station). The  $\mu$ P, an MC68EN360 running at a clock speed of 25 MHz, controls the operation of the station as determined by the station software (contained in a FLASH SIMM module) and the station codeplug (EEPROM).

##### Communications Buses

The Host  $\mu$ P provides five general-purpose serial communications buses, as follows:

- **SCC1** — Used as Ethernet port for high-speed communications, either to allow station software to be downloaded from a local PC into the FLASH memory
- **SCC3** — Used as the Interprocessor Communications Bus (HDLC protocol) to allow the Host  $\mu$ P to communicate with the Wireline Interface Board and other optional modules
- **SCC4** — Used as RS-232 port for connections to external equipment, such as a modem
- **SMC1** — Used as RS-232 port for RSS communications (9-pin D-type connector #20 on backplane)
- **SMC2** — Used as RS-232 port for RSS communications (9-pin D-type connector located on SCM front panel)

##### Address and Data Buses

The  $\mu$ P is equipped with a 28-line address bus used to access the non-volatile memory, DRAM memory, and provide control (via memory mapping) for other circuitry in the SCM. A 32-line data bus (buffered for the non-volatile memory) is used to transfer data to/from the SCM memory, as well as other SCM circuitry.

##### SPI Bus

The Host  $\mu$ P also controls the SPI bus, a general-purpose communications bus that allows the Host  $\mu$ P to communicate with other modules in the station.

*(continued)*



---

## Host Microprocessor (Continued)

### ***DRAM Controller***

The Host  $\mu$ P provides signals necessary to access and refresh the DRAM memory.

### ***25 MHz Clock Circuitry***

A crystal-controlled 25 MHz clock circuit and buffer provide the 25 MHz clock signal to the Host  $\mu$ P.

---

## Non-Volatile Memory

### ***Station Software FLASH Memory***

The station software resides in a 512k x 32 FLASH SIMM module. The FLASH SIMM is accessed by the Host  $\mu$ P via the 28-line Host Buffered Address Bus and the 32-line Host Buffered Data Bus.

### ***Codeplug EEPROM***

The data which determines the station personality resides in an 8K x 8 codeplug EEPROM. Stations are shipped from the factory with generic default data programmed into the codeplug EEPROM. Field programming is performed during installation using the Radio Service Software (RSS) program to enter additional customer-specific data, such as site output power, time-out timer settings, etc.

---

## DRAM Memory

Each SCM contains a 2M x 32 DRAM SIMM into which the station software code is downloaded and run. The DRAM also provides short-term storage for data generated/required during normal operation. Read and write operations are performed using the Host Buffered Address and Host Buffered Data buses.

The DRAM memory locations are sequentially refreshed by the column and row signals from the Host  $\mu$ P.

---

## External Line Interface Circuitry

### **Ethernet Port**

An Ethernet port is provided via a BNC connector on the station backplane which allows the station to connect into the Ethernet local network of an *IntelliRepeater* trunking site. The Ethernet port may also be used to allow station software to be downloaded from a local PC into the FLASH SIMM module. This Ethernet port is provided by Host  $\mu$ P serial communication bus SCC1 (which supports 10Base-2 architecture).

### **General Purpose RS232 Serial Port**

A general purpose RS-232 communications port is provided by Host  $\mu$ P serial communication bus SCC4. This port is available at a DB-25 connector (#15) located on the station backplane, and may be used to connect external equipment (e.g., an external modem).

### **RSS Port (Backplane)**

A 9-pin D-type connector (#20) is provided on the station backplane to allow service personnel to connect a PC loaded with the Radio Service Software (RSS) and perform programming and maintenance tasks. The RSS port may also be used to allow station software to be downloaded from a local PC into the FLASH SIMM module. This RSS port is provided by Host  $\mu$ P serial communication bus SMC1 which communicates with the RSS terminal via EIA-232 Bus Receivers/Drivers.

### **RSS Port (Front Panel)**

A 9-pin D-type connector is provided on the SCM front panel to allow service personnel to connect a PC loaded with the Radio Service Software (RSS) and perform programming and maintenance tasks. The RSS port may also be used to allow station software to be downloaded from a local PC into the FLASH SIMM module. This RSS port is provided by Host  $\mu$ P serial communication bus SMC2 which communicates with the RSS terminal via EIA-232 Bus Receivers/Drivers.

---

## Digital Signal Processor (DSP) and DSP ASIC Circuitry

### **General**

All station transmit and receive audio/data is processed by the DSP and related circuitry. This circuitry includes the DSP IC, the DSP ASIC, and the DSP ASIC Interface Circuitry. All audio signals input to or output from the DSP are in digitized format.

**Inputs** to the DSP circuitry are:

- Digitized receive signals from the Receiver Module
- Audio from handset or microphone connected to appropriate SCM front panel connector; signal is digitized by CODEC (p/o Audio Interface Circuitry) before being sent to DSP via Audio Interface Bus
- Digitized voice audio/data from Wireline Interface Board and other optional modules via TDM bus
- ASTRO modem data from Wireline Interface Board via HDLC bus
- *SECURENET* modem data from Wireline Interface Board via HDLC bus
- 6809/MRTI transmit audio

**Outputs** from the DSP circuitry are:

- Digitized voice audio/data from DSP to Wireline Interface Board and other optional modules via TDM bus
- Digitized voice audio from DSP to external speaker, built-in speaker, or handset earpiece via Audio Interface Bus and Audio Interface Circuitry
- Digitized voice audio/data from DSP to Exciter Module (modulation signals) via Audio Interface Bus and Audio Interface Circuitry
- 6809/MRTI transmit audio

### **Digital Signal Processor (DSP)**

The DSP, a 56002 operating at an internal clock speed of 60 MHz, accepts and transmits digitized audio to/from the various modules in the station. The DSP provides address and data buses to receive/transmit digitized audio (via the DSP ASIC) and to access the DSP program and signal processing algorithms contained in three 32K x 8 SRAM ICs. Three additional 32K x 8 SRAM ICs are provided for data storage.

### **DSP ASIC**

The DSP ASIC operates under control of the DSP to provide a number of functions, as follows:

- Interfaces with the DSP via the DSP address and data buses
- Accepts 16.8 MHz signal from Station Reference Circuitry and outputs a 2.1 MHz reference signal used throughout the station
- Provides interfaces for the HDLC bus, TDM bus, and serial bus used to communicate with the Receiver Module,
- Accepts digitized data from Receiver Module via DSP ASIC Interface Circuitry
- Provides interfaces for several A/D and D/A converters

---

## Station Reference Circuitry

**Note:**

Two BNC connectors (one 50  $\Omega$  input located on SCM front panel, one high impedance input located on the station backplane) are provided to allow an external 5/10 MHz source to be input to the OSC<sub>in</sub> input to the PLL to perform frequency netting. Refer to the Maintenance section in this manual for recommended intervals and procedures for netting the station reference.

The Station Reference Circuitry consists of a phase-locked loop comprised of a high-stability VCO and a PLL IC. The output of the VCO is a 16.8 MHz signal which is fed to the DSP ASIC. The ASIC divides the signal by 8 and outputs a 2.1 MHz signal which is separated and buffered by a splitter and output to the Exciter Module and Receiver Module as 2.1 MHz REF.

The Station Reference Circuitry may operate in one of three modes:

- **Normal Mode** — In this mode, the control voltage is turned off (via control voltage enable switch) and the high-stability VCO operates in an open loop mode; stability of the VCO in this mode is 1 PPM per year.
- **Manual Netting Mode** — Periodically, an external 5/10 MHz source is required to fine tune, or “net”, the 16.8 MHz reference signal. In this mode, the PLL compares the 5/10 MHz reference and a sample of the 16.8 MHz VCO output and generates up/down pulses. The Host  $\mu$ P reads the pulses (via SPI bus) and sends correction signals (via SPI bus) to the VCO to adjust the output frequency to 16.8 Mhz  $\pm$ 0.3 ppm.
- **High-Stability Mode** — For some systems (e.g., Simulcast systems), the free-running stability of the VCO is unacceptable for optimum system performance. Therefore, an external 5/10 MHz source is connected permanently to one of the BNC connectors. In this mode, the PLL compares the 5/10 MHz reference and a sample of the 16.8 MHz VCO output and generates a dc correction voltage. The control voltage enable switch is closed, allowing the control voltage from the PLL to adjust the high-stability VCO frequency to 16.8 Mhz  $\pm$ 0.3 ppm. The VCO operates in this closed loop mode and is continually being frequency controlled by the control voltage from the PLL.

---

## HDLC Bus Control Circuitry

The HDLC Bus Control Circuitry provides high-impedance buffering and data routing for the Interprocessor Communications Bus (a serial data bus implementing HDLC protocol). This bus allows the Host  $\mu$ P to communicate with the microprocessor located on the Wireline Interface Board and other optional modules via an interprocessor communications bus.

## Audio Interface Circuitry

### General





The Audio Interface Circuitry interfaces external analog audio inputs and outputs with the DSP circuitry. Most of the local audio processing is performed by a custom Local Audio ASIC.

### External Audio Sources

A multiplexer, under control of the Host  $\mu$ P, is used to select one of six possible external audio input sources (four for diagnostic loopback signals, one for 6809/MRTI transmit audio, and one for handset or microphone audio). The selected audio source signal is converted to a digital signal by the A/D portion of the CODEC circuit and sent to the DSP ASIC via the Audio Interface Bus. The DSP circuitry processes the signal and routes it to the desired destination.

### External Audio Destinations

Digitized audio from the DSP circuitry is input to the D/A portion of the CODEC IC and is output to one of four external devices:

- External Speaker — connects to RJ-11 jack (  ) located on SCM front panel
- Handset Earpiece/Microphone — connects to RJ-11 jack (  ) located on SCM front panel
- Local Built-In Speaker — internal speaker and 1/2 W audio amplifier; may be switched on/off and volume controlled by using volume up (  ) and down (  ) buttons on SCM front panel
- J14 on Station Backplane — 6809/MRTI receive audio output to external MRTI Module

### Exciter Modulation Signals

Digitized audio/data intended to be transmitted from the station is output from the DSP circuitry to a D/A converter (internal to the Local Audio ASIC) via the TX/Voice Audio signal (p/o the Serial Synchronous Interface bus, connected between the DSP and the DSP ASIC). The digitized signal is converted to analog, level shifted and amplified, and fed to a 0–6 kHz filter. The output of the filter is then fed to one of the inputs of a multiplexer. The output of the multiplexer is fed to two individual digitally controlled potentiometers (each of which is adjusted by the Host  $\mu$ P via the SPI Bus) and output to the Exciter Module as modulation signals VCO MOD AUDIO and REF MOD AUDIO.

---

## Input/Output Ports

### **Input Ports**

Two general-purpose multi-line input ports are provided to allow various input signals from the SCM and station circuitry to be accepted and sent to the Host  $\mu$ P. The two ports (I/O Port P0 In and I/O Port P1 In) are comprised of 32 and 24 lines, respectively, which come from circuitry in the SCM as well as other modules in the station via the backplane. The buses are input to buffers which make the data available to the Host  $\mu$ P via the Host Buffered Data Bus. Typical inputs include the pushbutton switches located on the SCM front panel and the MIC PTT signal from the handset/microphone.

### **Output Ports**

Two general-purpose multi-line output ports are provided to allow various control signals from the Host  $\mu$ P to be output to the SCM and station circuitry via the backplane. The two ports (I/O Port P0 Out and I/O Port P1 Out) are comprised of 32 and 8 lines, respectively, which come from the Host Buffered Data Bus via latches. Typical output control signals include the control lines for the eight LEDs located on the SCM front panel and the local speaker enable signal.

---

## 6809/MRTI Interface Circuitry

### **6809 Trunking Interface**

TX DATA from the 6809 Trunking Controller is input to the station via J14 on the station backplane. The signal is routed thru nominal filtering on the 6809/MRTI Interface Circuitry and fed to the Audio Interface Circuitry. The T DATA signal is then waveshaped/filtered and fed to an A/D converter (internal to the Local Audio ASIC), which outputs a digital signal to the DSP via the Audio Interface Bus.

6809 RX AUDIO is output from the DSP to the Local Audio Circuitry via the Audio Interface Bus. The signal is amplified, filtered, buffered, and output thru nominal filtering on the 6809/MRTI Interface Circuitry to the 6809 Trunking Controller via J14 on the station backplane.

### **MRTI Interface**

MRTI TX AUDIO from an external MRTI module is input to the station via J14 on the station backplane. The signal is routed thru the 6809/MRTI Interface Circuitry and fed to one input of an 6-to-1 multiplexer. If selected, the MRTI TX AUDIO signal is converted to a digital signal by a CODEC (internal to the Local Audio ASIC) and sent to the DSP ASIC via the Audio Interface Bus.

MRTI RX AUDIO is output from the DSP to the Local Audio ASIC via the Audio Interface Bus. The signal is amplified, filtered, buffered, and output thru the 6809/MRTI Interface Circuitry to the external MRTI Module via J14 on the station backplane.

---

## Supply Voltages Circuitry

The SCM contains on-board regulator and filtering circuitry to generate the various operating voltages required by the SCM circuitry. +14.2 V and +5V from the backplane are used as sources for the following supply voltage circuits:

- **VCCA Supply Circuitry** — provides VCCA (+5V) for the Audio Interface Circuitry in the SCM.
- **Filtering Circuitry** — filters the +14.2 V and +5V from the backplane to provide A+ and VCC, respectively, for the SCM digital circuitry.

## 4 FUNCTIONAL THEORY OF OPERATION (CLN7098A LED Board)

The following theory of operation describes the operation of the CLN7098A LED Board circuitry at a functional level. The information is presented to give the service technician a basic understanding of the functions performed by the module in order to facilitate maintenance and troubleshooting to the module level. Refer to Figure 4 for a block diagram of the CLN7098A LED Board.

---

### Front Panel LEDs and Switches

**Note:**

Refer to the *Troubleshooting* section of this manual for complete details on the interpretation of the LEDs.

**Note:**

Refer to the *Operation* section of this manual for complete details on the use of the pushbutton switches.

#### LEDs

Eight status LEDs are provided on the SCM front panel to provide visual indications of various station operating conditions. The LEDs are controlled by eight lines from I/O Port P0 Out.

#### Switches

Four momentary contact pushbutton switches are provided on the SCM front panel to allow various station functions to be selected. Depressing a pushbutton causes a high to be sent to the Host  $\mu$ P via I/O Port P0 In.

---

### Front Panel Connectors

Four connectors are provided on the SCM front panel to interface with external equipment:

- **RSS Port** — DB-9 connector used for connection to a PC loaded with Radio Service Software (RSS) for configuring/servicing the station
- **External Speaker Connector** — RJ-11 connector used for connection to an external speaker (Model HSN1000)
- **External Handset/Microphone** — RJ-11 connector used for connection to an external handset (Model TMN6164) or microphone (Model HMN1001)
- **5/10 MHz Input** — BNC connector used for connection to an external source of 5 or 10 MHz to be used as a station reference



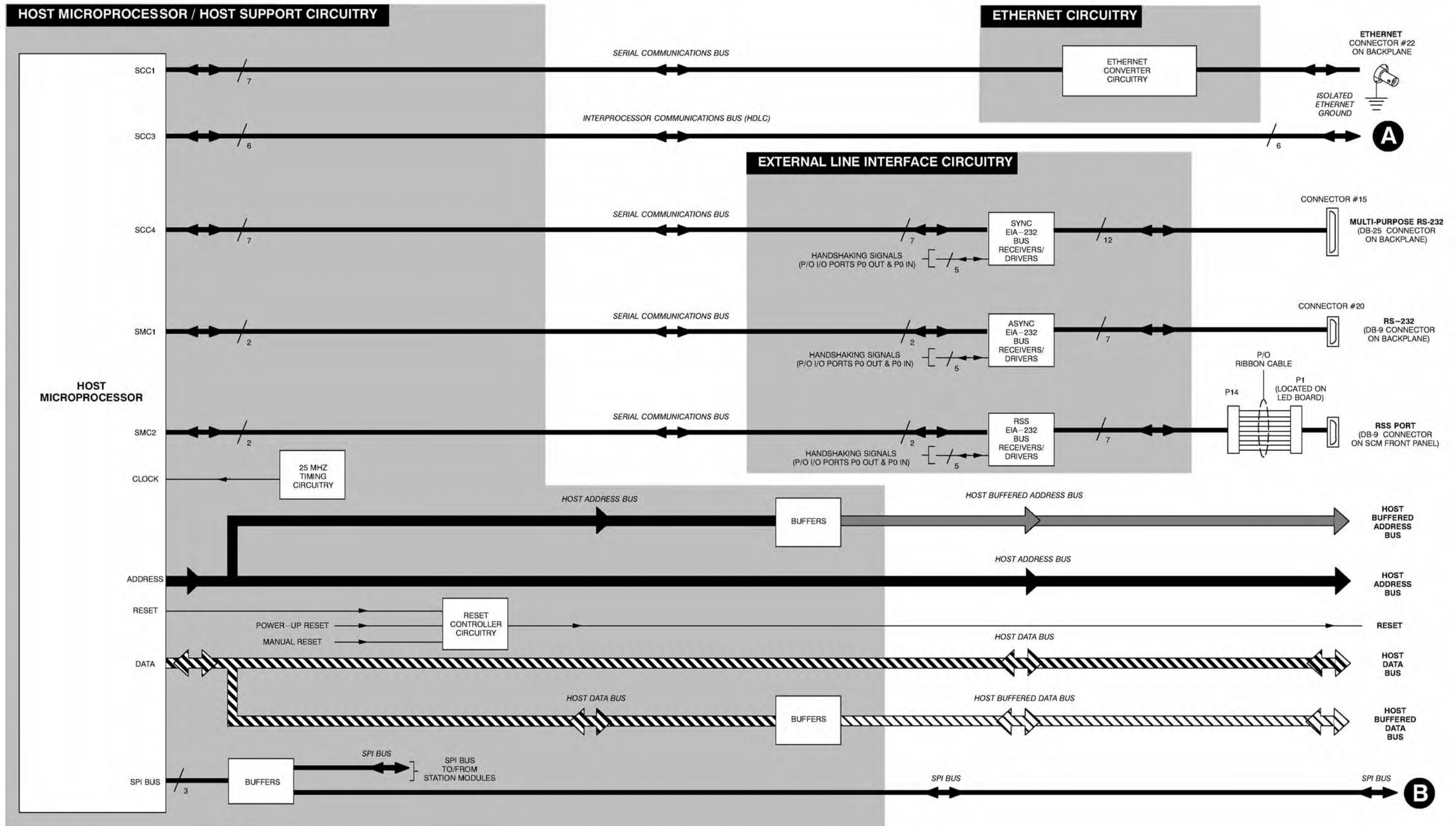

Figure 3. CLN7060A/CLN7558A Station Control Board Functional Block Diagram (1 of 5)

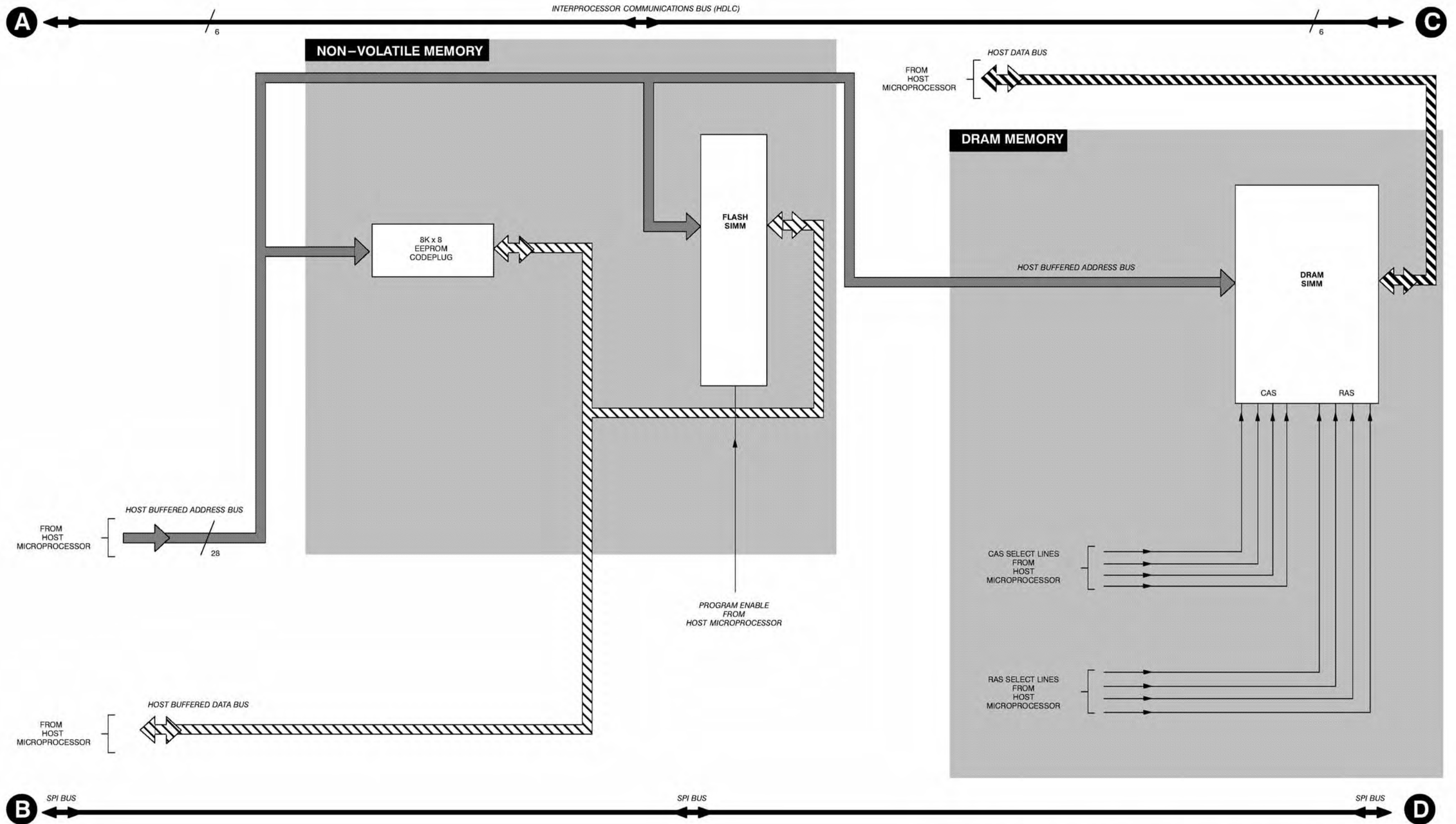

Figure 3. CLN7060A/CLN7558A Station Control Board Functional Block Diagram (2 of 5)



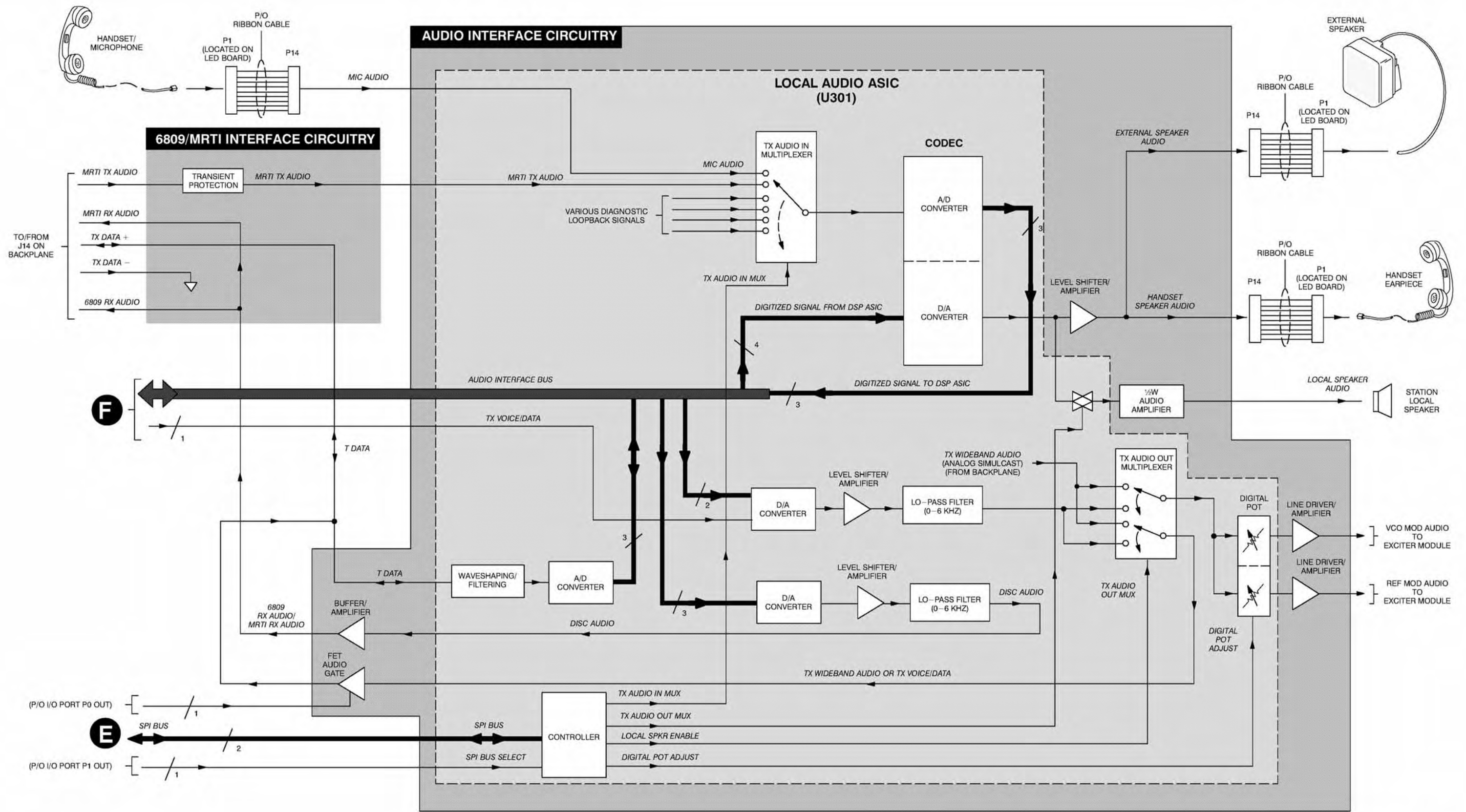

Figure 3. CLN7060A/CLN7558A Station Control Board Functional Block Diagram (4 of 5)

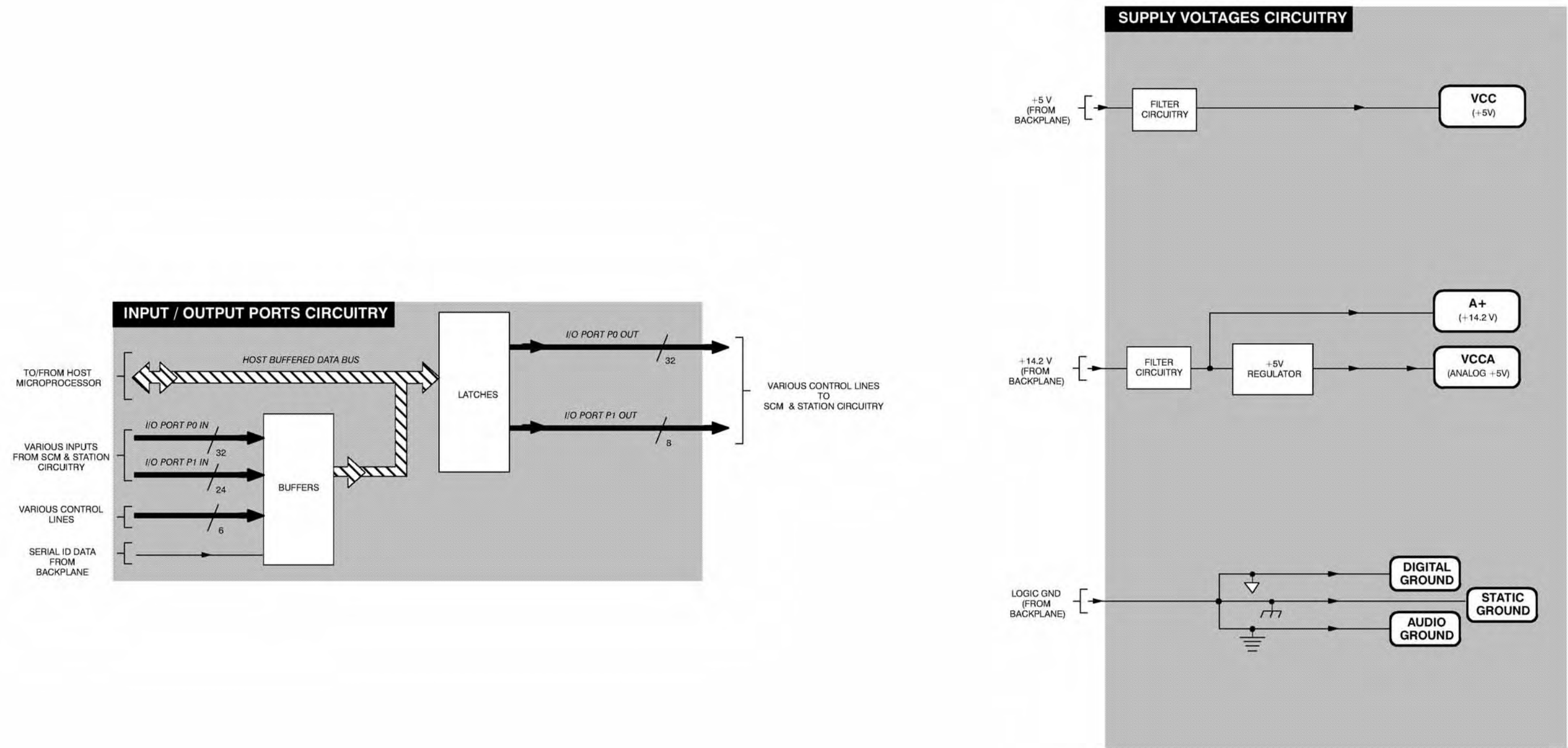

Figure 3. CLN7060A/CLN7558A Station Control Board Functional Block Diagram (5 of 5)

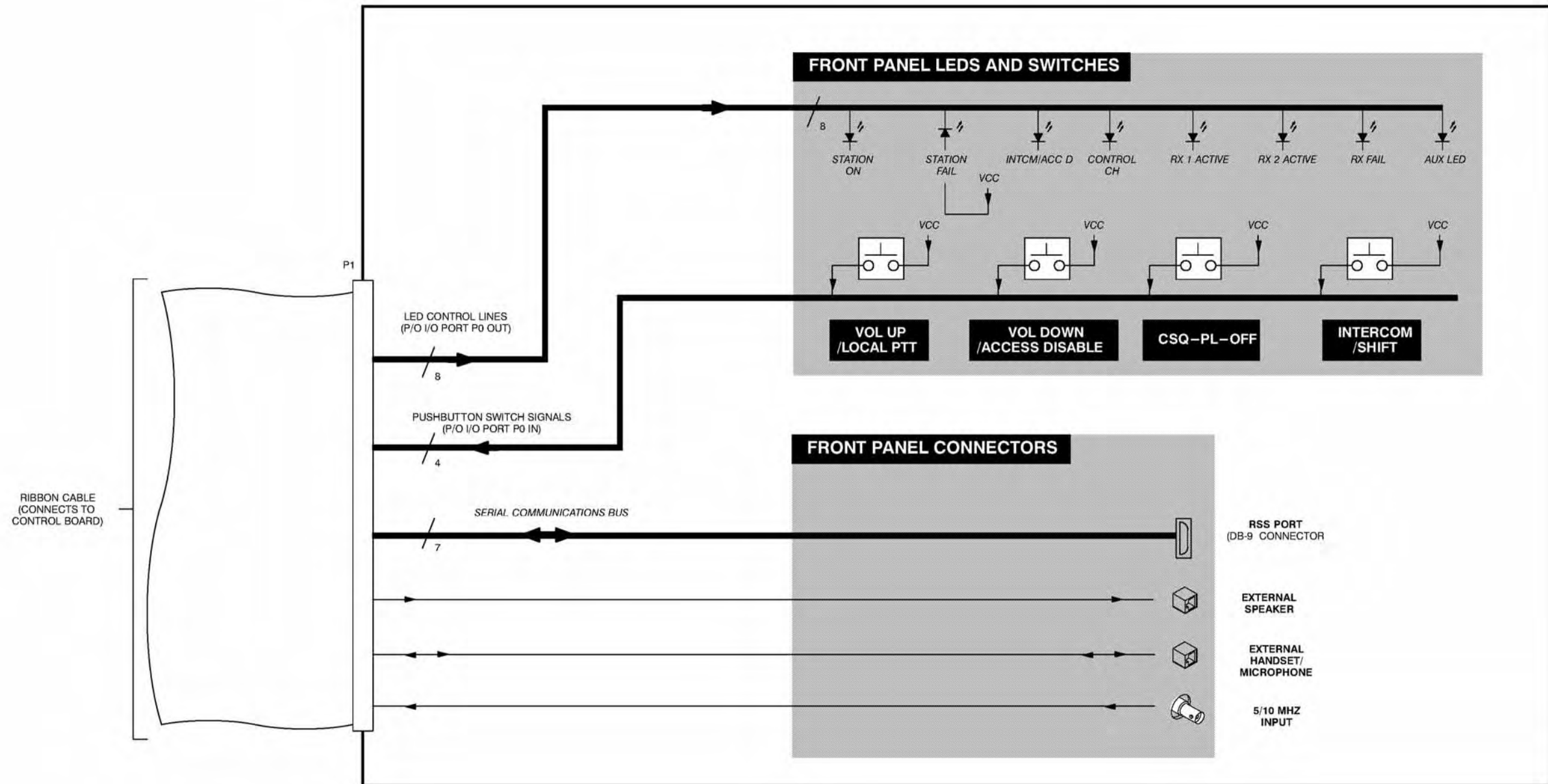

Figure 4. CLN7098A LED Board Functional Block Diagram

---

---

## 1 DESCRIPTION

The model CLN7692 station control module (SCM) is described in this section. A general description, identification of controls, indicators, and inputs/outputs, a functional block diagram, and functional theory of operation are provided. The information provided is sufficient to give service personnel a functional understanding of the module, allowing maintenance and troubleshooting to the module level. (Refer also to the *Maintenance and Troubleshooting* section of this manual for detailed troubleshooting procedures for all modules in the station.)

---

### General Description

The SCM serves as the main controller for the station. The SCM board contains a MPC860EN host microprocessor (host  $\mu$ P), a DSP56311 digital signal processor (DSP), and support circuitry, which combine to provide signal processing and operational control over the other station modules. The SCM also contains the station operating software and parameters that define the personality of the station, including system capabilities and operating variables such as output power and operating frequency.

The CLN7692 SCM consists of the Enhanced Performance Integrated Control (EPIC) IV module which supports general station control, communications, and signal processing functions, as well as certain system specific functions. Several versions of the module are available to support various applications including conventional, 6809 trunking, IntelliRepeater, data base stations and wireless data.

---

### Overview of Circuitry

The SCM contains the following circuitry:

- **Host Microprocessor** — MPC860EN 50MHz PowerPC based central processor of the SCM with 32-bit wide data bus, 4 GB address space and background debug mode
- **SDRAM Memory** — consists of SDRAM into which station software is loaded and executed with a bus width of 32 bits, and a bus speed of 50MHz.
- **Non-Volatile Memory** — consists of FLASH with a bus width of 32 bits that contains the station operating software and data. There is

an additional FLASH with a bus width of 16 bits that contains boot and test code, and station codeplug data.

- **HDLC Bus Control Circuitry** — provides bus control to allow the host  $\mu$ P communications port SCC3 to communicate with the Wireline Interface Board and other optional modules via the HDLC inter-processor communications bus
- **Serial Peripheral Interface (SPI)** — Bus supports EPIC IV and other SCMs
- **External Line Interface Circuitry** — consists of two RS-232 asynchronous serial ports (one on front panel and one on back panel), one RS-232 synchronous serial port (back panel), and one external 10BaseT Ethernet port (connectors on backplane).
- **Digital Signal Processor (DSP) and DSP ASIC Circuitry** — DSP56311 processor operating at a core frequency of 100MHz performs high-speed processing of audio and signaling data signals.
- **Station Reference Circuitry** — 16.8MHz temperature compensated crystal oscillator capable of 1ppm performance and software enhanced fault tolerant control used to generate the reference signals throughout the station.
- **Audio Interface Circuitry** — consists of the DSP, DSP ASIC, local audio ASIC that process and route the various audio input signals (such as microphone, MRTI, receiver, or the wireline audio) to output devices (such as the local speaker, MRTI, exciter modulation, or the wireline audio inputs, when enabled).
- **Input / Output Ports Circuitry** — consists of general inputs and outputs on the CPLD, DSP ASIC and the host  $\mu$ P. The input and output signals are used to control and monitor station functions.
- **Front Panel LEDs and Switches** — general purpose input/output ports control eight status LEDs and accept inputs from four pushbutton switches, all located on the front panel.
- **Supply Voltage Circuitry** — contains filtering and regulator circuitry that accepts +14.2 V and +5 V from the backplane and generates the operating voltages required by the SCM circuitry.



## 2 CONTROLS, INDICATORS AND INPUTS/OUTPUTS

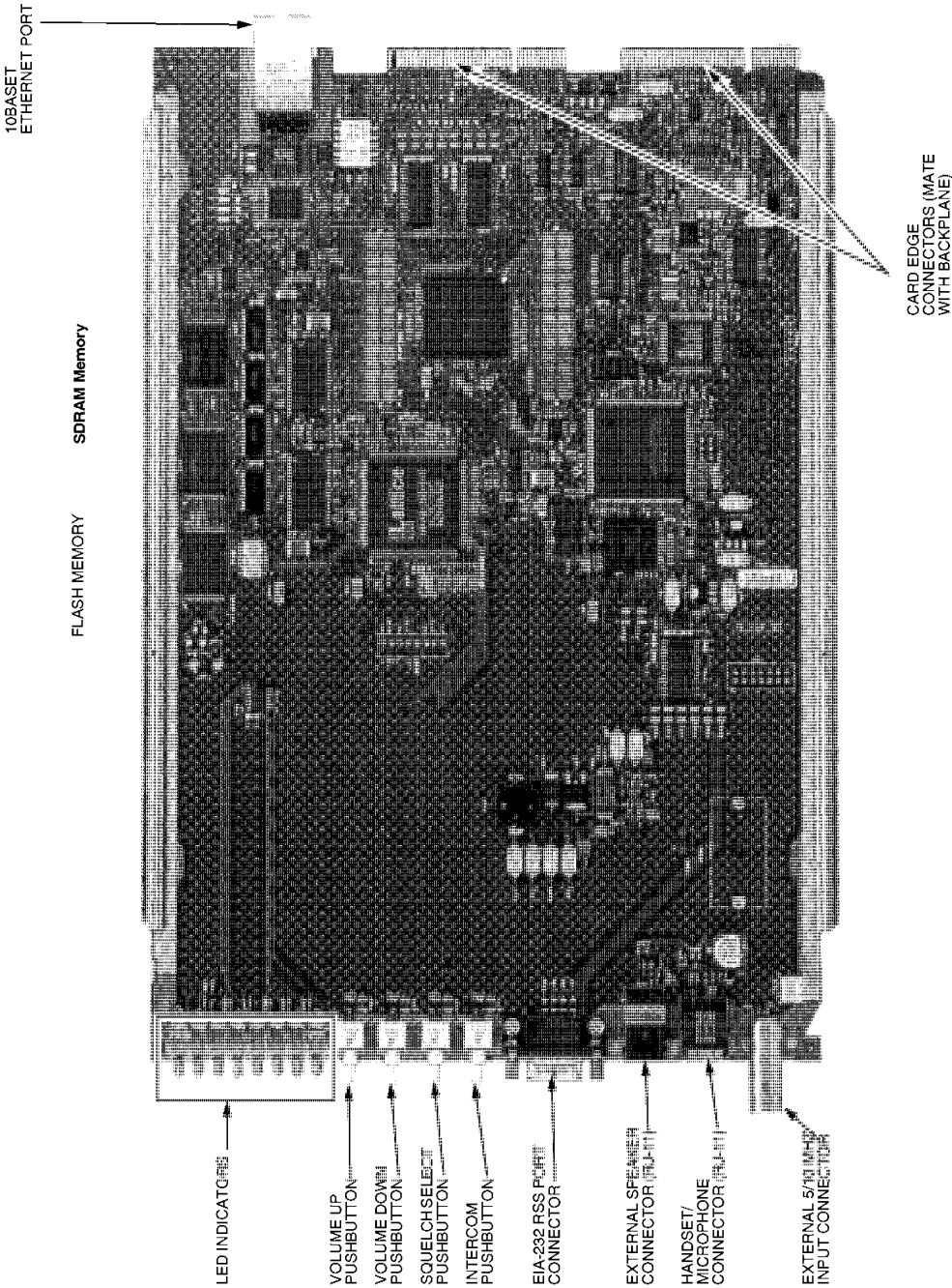

Figure 1 EPIC IV

---

## 3 FUNCTIONAL THEORY OF OPERATION

The following theory of operation describes the operation of the SCM circuitry at a functional level. The information is presented to give the service technician a basic understanding of the functions performed by the module in order to facilitate maintenance and troubleshooting to the module level.

---

### Host Microprocessor (See Figure 2, Sheet 1 of 5)

#### *Overview*

The host  $\mu$ P serves as the main controller for the SCM and therefore the station. The  $\mu$ P runs at a clock speed of 50 MHz and controls the operation of the station as determined by the station software contained in the FLASH.

#### *Communications Buses*

The Host  $\mu$ P provides six general-purpose serial communications buses, as follows:

- **SCC1** — Used as Ethernet port for high speed communications, either to connect to the Ethernet local network of an IntelliRepeater trunking site or to allow station software to be downloaded from a local PC into the FLASH memory.
- **SCC2** — Used as communications port to allow the station to connect to the local network of an IntelliRepeater trunking site; a 9-pin D-type connector located on the backplane provides external connections.
- **SCC3** — Used as the interprocessor communications bus (HDLC protocol) to allow the Host  $\mu$ P to communicate with other optional modules.
- **SCC4** — Used as miscellaneous general purpose I/O.
- **SMC1** — Used as RS-232 port for RSS communications (9-pin D-type connector on the backplane.)
- **SMC2** — Used as RS-232 port for RSS communications (9-pin D-type connector located on SCM front panel.)

#### *Address and Data Buses*

The  $\mu$ P has a 32-line address bus used to access the non-volatile memory, SDRAM memory, and provide control (via memory mapping) for other circuitry in the SCM. A 32-line data bus (buffered for the non-volatile memory) is used to transfer data to/from the SCM memory, as well as other SCM circuitry.

#### *SPI Bus*

The host  $\mu$ P also controls the SPI bus, a general-purpose communications bus that allows the host  $\mu$ P to communicate with other modules in the station.

---

**SDRAM Controller**

The host  $\mu$ P provides signals necessary to access and refresh the SDRAM memory.

**25 MHz Clock Circuitry**

A crystal-controlled 25 MHz clock circuit and buffer provide the 25 MHz clock signal to the host  $\mu$ P. This clock is internally multiplied in the  $\mu$ P, allowing an operational frequency of 50MHz.

---

**Non-Volatile Memory (See Figure 3, Sheet 2 of 5)****Station Software FLASH Memory**

The station software resides in 16 MB of FLASH memory with a 32 bit bus. The host processor accesses the FLASH via the 32-line host buffered address bus and the 32-line host buffered data bus.

**Station Boot and Configuration FLASH Memory**

The station boot and configuration software resides in 4 MB of FLASH memory utilizing 16 bits of a 32 bit bus. The FLASH memory is accessed by the host  $\mu$ P via the 32-line host buffered address bus and the 32-line host buffered data bus.

---

**SDRAM Memory**

Each SCM contains a minimum of 32 MB of SDRAM memory with a 32 bit bus into which the station software code is downloaded and executed. This SDRAM memory is comprised of two banks. The SDRAM also provides short-term storage for data generated or required during normal operation. Read and write operations are performed using the host address and data buses.

The SDRAM memory locations are sequentially refreshed by the column and row signals from the host  $\mu$ P.

---

**External Line Interface Circuitry****CSS Port (Front Panel)**

This asynchronous serial port is provided by SMC2 of the host  $\mu$ P, configured as a universal asynchronous receiver-transmitter (UART). Only the TX and RX signals are supported by the SMC. Optional handshake signals may be provided, under software control, via the host input/output ports. A 9-pin, female D-type connector (P1) is provided at the front panel edge of the LED board.

**General Purpose Backplane Asynchronous RS-232 Port**

This serial port is provided by SMC1 of the host  $\mu$ P, configured as a UART. Only the TX and RX signals are supported by the SMC. Optional

handshake signals may be provided, under software control, via the host input/output ports. The signals for this port are routed (via RS232 drivers/receivers) to a 9-pin, female D-type connector located on the backplane (Connector 20).

#### **General Purpose Backplane Synchronous RS-232 Port**

This serial port provides for future enhancement. This port interfaces to SCC2 of the host  $\mu$ P and supports both asynchronous and synchronous UART protocols. In addition to TX and RX, the clock signals and standard handshake signals are handled directly by the host  $\mu$ P. Optional handshake signals may be provided, under software control, via the host input/output ports. The signals for this port are routed (via RS232 drivers/receivers) to a 25-pin, female D-type connector located on the backplane (connector 15).

#### **Ethernet**

Ethernet (10baseT) is a standard feature of the EPIC IV module. External Ethernet signaling is controlled by SCC1 of the host  $\mu$ P. SCC1 interfaces to the SIA, which performs the Manchester encoder/decoder function via the host  $\mu$ P signals. The isolation transformers and the SIA provide signal conditioning and translation. The physical Ethernet 10baseT port is located on the station backplane.

---

### **Digital Signal Processor (DSP) and DSP ASIC and Local Audio ASIC (See Figure 4, Sheet 3 of 5)**

#### **General**

All station transmit and receive audio/data is processed by the DSP, DSP ASIC, local audio ASIC, and related circuitry. All audio signals handled by the DSP are in digitized format.

**Inputs** to the DSP circuitry are:

- Digitized receive signals from the receiver module
- When enabled, audio from handset or microphone connected to appropriate SCM front panel connector; signal is digitized by the audio interface circuitry, local audio ASIC and DSP ASIC before being sent to the DSP.
- When enabled, digitized voice audio/data from wireline interface board and other optional modules via time division multiplexing (TDM) bus to the, local audio ASIC and DSP ASIC before being sent to the DSP.
- When enabled, ASTRO modem data from wireline interface board via HDLC bus to the local audio ASIC and DSP ASIC before being sent to the DSP
- 6809/MRTI transmit audio to the local audio ASIC and DSP ASIC before being sent to the DSP

**Outputs** from the DSP circuitry are:

- When enabled, digitized voice audio/data from DSP to DSP ASIC and via the local audio ASIC to the wireline interface board and other optional modules via TDM bus
- When enabled, digitized voice audio from DSP to DSP ASIC and via the local audio ASIC to the external speaker, built-in speaker, or handset earpiece via audio interface circuitry
- Digitized voice audio/data from DSP to DSP ASIC and via the local audio ASIC to the exciter module (modulation signals) via the audio interface circuitry
- Digitized voice audio/data from DSP to DSP ASIC and via the local audio ASIC to the 6809/MRTI transmit audio

### ***Digital Signal Processor (DSP) Circuitry***

The DSP56311 provides performance enhancements over those used on other SCMs. Features include:

- Up to 150MIPS with 150MHz clock, 100MIPs available with implementation of a 100MHz core clock.
- 100% object code compatible with the 56K Core
- Fully pipelined 24x24 parallel multiplier-accumulator
- 16 bit arithmetic support
- On-chip phase lock loop (PLL)
- On-chip emulator (OnCE)
- 128Kx24 bit on-chip SRAM
- Glueless interface to SRAMs and SSRAMs
- Enhanced filter co-processor (EFCOP)
- Two enhanced synchronous serial interfaces (ESSI)
- Up to 34 programmable general purpose I/O pins (GPIO) (depends on peripherals used)
- Very low power design
- 3.3VDC I/O, 1.8VDC core

The DSP is hardware configured to enter the bootstrap through HI08 bus mode on power up. This allows the DSP to receive its program information upon power up from the host  $\mu$ P's memory bus, through its host interface port. The program code is then loaded into internal program RAM that allows zero wait state execution.

### ***DSP ASIC (DSP Glue ASIC)***

The DSP ASIC, also known as the DSP glue ASIC for FDMA systems (DGA4F), was designed to replace the DGA3F. The DSP ASIC operates under the control of the DSP to provide the following functions:

- DGA4F is a field programmable gate array (FPGA) instead of a gate array.
- DGA4F utilizes 3.3V I/O with a 2.5V core.
- The DGA4F interfaces to the host  $\mu$ P through the memory bus and the receive SSI. For the memory bus interface, it utilizes the uppermost 16 data bits for data transfers.

- Provides a serial receive data input from the station receiver that is translated and output to the DSP (SSI)
- When enabled, provides a HDLC interface with the host  $\mu$ P that is translated to a TDM interface to other modules
- Provides a digital to analog interface to the local audio ASIC
- When enabled, provides a Wireline Board interface to the local audio ASIC
- Provides a CODEC interface to the local audio ASIC
- Provides site timing through a 1PPS input
- Accepts a 16.8MHz signal from the station reference circuitry and outputs a 2.1 MHz reference signal used throughout the station
- The FPGA is programmed in slave parallel mode by the DSP via the host  $\mu$ P. The FPGA data is stored in FLASH memory then transferred to the DSP which then programs the FPGA. After the FPGA has been programmed its reset signal is driven high by the DSP.

#### ***Host Interface***

Interfacing the DSP to the host  $\mu$ P is done through the host interface port. The DSP code is downloaded from the host  $\mu$ P through this port as well as transfer of control information. The DSP is treated as a memory-mapped peripheral by the host  $\mu$ P.

#### ***Receiver Interface***

The station receiver audio path originates from the receiver module. The receive audio is converted into digital I and Q samples by the ABACUS IC and then sent over the backplane to the SCM. The digital I and Q samples are received by DSP ASIC and then re-clocked to the DSP. The data samples can also be made available to the DSP via memory-mapped locations. If a second receiver is in use, its receive data is only available to the DSP as memory-mapped locations. The DSP then performs audio processing on the received data.

#### ***General Purpose I/O***

The FPGA supports six bidirectional general purpose I/O lines. This port can be accessed by the DSP through the DSP ASIC.

---

## **Station Reference**

The 16.8MHz station reference is generated by a temperature compensated crystal oscillator capable of 1ppm performance. When the 5MHz reference frequency is present the oscillator is steered by a PLL frequency synthesizer. When the PLL is locked the steering voltage is recorded by the host  $\mu$ P. When the host detects that the 5MHz is not present it switches the steering voltage path from the PLL to a digital to analog convertor (DAC) that generates the steering voltage that was previously recorded. The 5MHz reference signal has an input swing (sine or square-wave) at the SCM of at least 3.0Vp-p and a constant duty cycle of 25-75%.

---

## HDLC Bus Control Circuitry

The HDLC bus control circuitry provides high-impedance buffering and data routing for the Inter-processor communications bus (a serial data bus implementing HDLC protocol). This bus allows the host  $\mu$ P to communicate with the host  $\mu$ P located on the wireline interface board and other optional modules via an interprocessor communications bus.

---

## Audio Interface Circuitry (See Figure 5, Sheet 4 of 5)

### **General**

The audio interface circuitry interfaces external analog audio inputs and outputs with the DSP circuitry.

### **External Audio Sources**

A multiplexer, under control of the host  $\mu$ P, is used to select one of eight possible external audio input sources:

- Four for diagnostic loopback signals that include loopback MRTI audio, loopback VCO audio and loopback ref mod audio
- Two for future use
- One for 6809/MRTI transmit audio
- One for handset or microphone audio and for future use

The selected audio source signal is converted to a digital signal by the CODEC A/D portion of the local audio ASIC and sent to the DSP ASIC via the audio interface bus. The DSP circuitry processes the signal and routes it to the desired destination.

### **External Audio Destinations**

Digitized audio from the DSP circuitry is input to the CODEC D/A portion of the local audio ASIC via the audio interface bus and is output to one of four external devices:

- External speaker connects to RJ-11 jack ( ) located on SCM front panel, when enabled.
- Handset earpiece/microphone connects to RJ-11 jack ( ) located on SCM front panel, when enabled.
- Local built-in speaker internal speaker and ½ W audio amplifier; may be switched on/off and volume controlled by using volume up ( ) and down ( ) buttons on SCM front panel, when enabled.
- J14 on station backplane - 6809/MRTI receive audio output to external MRTI Module

### **Exciter Modulation Signals**

Outbound audio to be transmitted over the air is written to the FPGA memory-mapped locations from the DSP. The DSP ASIC clocks the audio samples out to a 12 bit linear D/A in the local audio ASIC. The audio is then digitally filtered by a low pass filter within the local audio

ASIC and is sent out the backplane, destined for the exciter module as VCO MOD and REF audio. Audio can also be sent out a second similar path via the wideband Rx D/A converter in Epsilon to the MRTI port. (What is Epsilon?)

---

## **Input/Output Ports and Reset Circuitry (See Figure 6, Sheet 5 of 5)**

### ***General***

The input, output, 5MHz detect, and reset circuitry are implemented in a CPLD that provides most of the external glue logic functionality. Most of the CPLD functions are controlled and accessed by the host  $\mu$ P. The following list summarizes the supported host  $\mu$ P CPLD functions:

### ***Input Ports***

Two memory-mapped general-purpose input ports (40 bits total) are available to read various inputs from SCM and station circuitry. These input are in host addressable space for reading.

### ***Output Ports***

One memory-mapped general-purpose 32-bit registered output port is available to drive various control lines to the SCM and station circuitry. The output register is in Host addressable space for reading.

### ***5MHz Detection***

If the 5Mhz signal is lost the information is sent to the output port register and is accessible to the host  $\mu$ P via the host buffered data bus.

### ***Reset***

Various reset inputs from SCM and station circuitry that includes power-up reset from the power monitor, manual reset from the front panel (via the RESET switch on the front panel), software reset (via a set breakpoint) from the host  $\mu$ P, SRESET from the host  $\mu$ P, and the bidirectional HRESET. Reset states are in host  $\mu$ P addressable space for reading.

### ***Host Interrupt***

Interrupts the host via the IRQ TO HOST signal when P0\_IN inputs 5MHz\_Act, DAC\_Voltage\_Status, 16.8MHz\_Act, Pend\_Lock, Tx\_Host\_Reqx, 16.8MHz\_Clk, Link\_Integrity, or Exp\_Host\_Reqx are active. These interrupts are maskable and resetable. The DAC\_Voltage\_Status signal can also be programmed to be active on the rising or falling edge.

### ***Serial Identification***

The station serial identification number is read and stored in a register that is host  $\mu$ P addressable for read access.

### ***Interrupts (IRQs)***

An interrupt is generated to the host via the IRQ-TO-HOST signal when the various inputs from SCM and station circuitry inputs 5MHz\_Act,



DAC\_Voltage\_Status, 16.8MHz\_Act, Pend\_Lock, Tx\_Host\_Reqx, 16.8MHz\_Clk, Link\_Integrity, or Exp\_Host\_Reqx are active. These interrupts are maskable and resetable. The DAC\_Voltage\_Status signal can also be programmed to be active on the rising or falling edge.

---

## **6809/MRTI Interface Circuitry (See Figure 5, Sheet 4 of 5)**

### ***6809 Trunking Interface***

TX data from the 6809 trunking controller is input to the station via J14 on the station backplane. The signal is routed through nominal filtering on the 6809/MRTI interface circuitry and fed to the audio interface circuitry. The T DATA signal is then wave shaped/filtered and fed to an A/D converter, which outputs a digital signal to the DSP via the audio interface bus.

6809 RX audio is output from the DSP to the DSP ASIC and sent out the local audio interface bus via the audio interface bus to the audio interface circuitry. Here the digital signal is converted to analog, level shifted and amplified, filtered, buffered, and output through the 6809/MRTI interface circuitry to the 6809 trunking controller via J14 on the station backplane.

### ***MRTI Interface***

MRTI audio from an external MRTI module is input to the station via J14 on the station backplane. The signal is routed through the 6809/MRTI interface circuitry and fed to one input of an 8-to-1 multiplexer. If selected, the MRTI TX AUDIO signal is converted to a digital signal by the A/D portion of the CODEC IC and sent to the DSP ASIC via the audio interface bus.

MRTI RX audio is output from the DSP to the DSP ASIC and sent out the local audio interface bus via the audio interface bus to the audio interface circuitry. Here the digital signal is converted to analog, level shifted and amplified, filtered, buffered, and output through the 6809/MRTI interface circuitry to the 6809 trunking controller via J14 on the station backplane.

---

## **Front Panel LEDs and Switches (See Figure 7)**

### ***Front Panel LEDs***

Eight status LEDs are provided on the SCM front panel to provide visual indications of various station operating conditions. The LEDs are controlled by eight lines from I/O port P0 Out.

### ***LED Addresses and "ON" States***

The hardware addresses, "ON" states, and initial states for the LEDs are presented in the table below.

**Table 1: LED Addresses and States**

Control On	P0_OUT, bit 7	Logic '1'	OFF
Control Fail	P0_OUT, bit 6	Logic '0'	ON
Intercom	P0_OUT, bit 5	Logic '1'	OFF
Control Channel	P0_OUT, bit 4	Logic '1'	OFF
RX1 Active	P0_OUT, bit 3	Logic '1'	OFF
RX2 Active	P0_OUT, bit 2	Logic '1'	OFF
RX Fail	P0_OUT, bit 1	Logic '1'	OFF
Aux LED	P0_OUT, bit 0	Logic '1'	OFF

**Power Up and Reset Operation**

After power up and reset all LEDs momentarily illuminate to demonstrate functionality then turn off for at least 1 second before they display the actual state of their labeled function.

**Normal Operation**

The normal operation of the LEDs is defined below:

**Table 2: Normal LED Operation**

Control On	Green	On	Control Module fully functional.
		Flashing	Front panel switch press detected or 5MHz NET in process.
		Off	Control Module malfunction.
Control Fail	Red	On	Control Module failure or reset.
		Flashing	Station is in failsoft mode. (trunking systems only).
		Off	Control Module fully functional.
Intercom	Yellow	On	Station is in intercom mode.
		Flashing	Station is in access disable mode.
		Off	Station is not in intercom mode.
Control Channel	Green	On	Station is control channel (trunking systems only).
		Flashing	Flashes each time an ISW is decoded (trunking systems only).
		Off	Station is not control channel (trunking systems only).

**Table 2: Normal LED Operation**

RX1 Active	Green	On	Receiver 1 is active.
		Off	Receiver 1 is inactive.
RX2 Active	Green	On	Receiver 2 is active.
		Off	Receiver 2 is inactive.
RX Fail	Red	On	Neither receiver is functional.
		Flashing	Receiver 1 is not functional. (1 blink per second)
		Flashing	Receiver 2 is not functional. (2 blinks per second)
Aux LED	Green	Off	Both receivers are fully functional.
		On	Per customer requirement.
		Off	Per customer requirement.

**Front Panel Switches**

Four momentary contact pushbutton switches are provided on the SCM front panel to allow station functions to be selected. Pressing a push button causes a high signal to be sent to the host  $\mu$ P via I/O port P0 In.

The switches may be accessed and interpreted per the table below when enabled.

**Table 3: Front Panel Switch Addresses and Logic States**

Volume Up	0	PO_IN, bit 7	Switch Depressed	0
Volume Down	1	PO_IN, bit 6	Switch Depressed	0
Squelch Mode	2	PO_IN, bit 5	Switch Depressed	0
Intercom	3	PO_IN, bit 4	Switch Depressed	0

**Normal Switch Function Operation**

The switch function, except for the intercom switch, occurs after a valid low-to-high transition (button pressed). The intercom switch function occurs after a valid low-to-high then high-to-low transition (button pressed then released). The normal switch functions are described in the table below, when enabled.

**Note:** Each volume down button press lowers volume one step. Pressing and holding the volume down button for 2 seconds shuts off the local speaker. Therefore, pressing and holding the volume down button for 2 seconds has the effect of reducing the volume by one step and shutting off the local speaker. Pressing the volume up button raises the volume one step and turns on the local speaker at the same volume at which it was shut off. Thus repeatedly switching the speaker on and off leaves the volume level unchanged.

**Table 4: Normal Switch Functions**

Volume Up	Increment speaker volume one of 16 steps. Turn on local speaker, if off.	Step 10
Volume Down	Decrement speaker volume one of 16 steps.	Step 10
Volume Down (Hold 2 sec, see side note)	Turn off local speaker.	Speaker off
Squelch Mode	Step to next squelch state: (Off, CSQ, PL, Off)	CSQ
Intercom	Toggle intercom mode: (Off, On, Off)	Off

**Note:** Speaker on/off affects internal speaker only. Volume affects internal speaker, external speaker and handset.

**Volume Control**

The volume control for the local speaker, external speaker, and handset speaker can be performed by the DSP or by the wideband Rx D/A converter in Epsilon. The DSP-based volume steps are defined on a logarithmic scale.

**Supply Voltages Circuitry**

The SCM contains on-board regulator and filtering circuitry to generate the various operating voltages required by the SCM circuitry. +14.2 V and +5V from the backplane are used as sources for the following supply voltage circuits:

- +14.2 Vdc provides VCCA (+5V) for the analog circuitry
- + 5 V VCC C1809 Regulatory Circuit provides:
  - +3.3Vdc by means of a high efficiency DC to DC converter to power most of the digital logic on the board,
  - +2.5V U1801-4 reference voltage (½ of VCC) for the Audio Interface Circuitry in the SCM
  - +1.8Vdc for the DSP core circuitry.

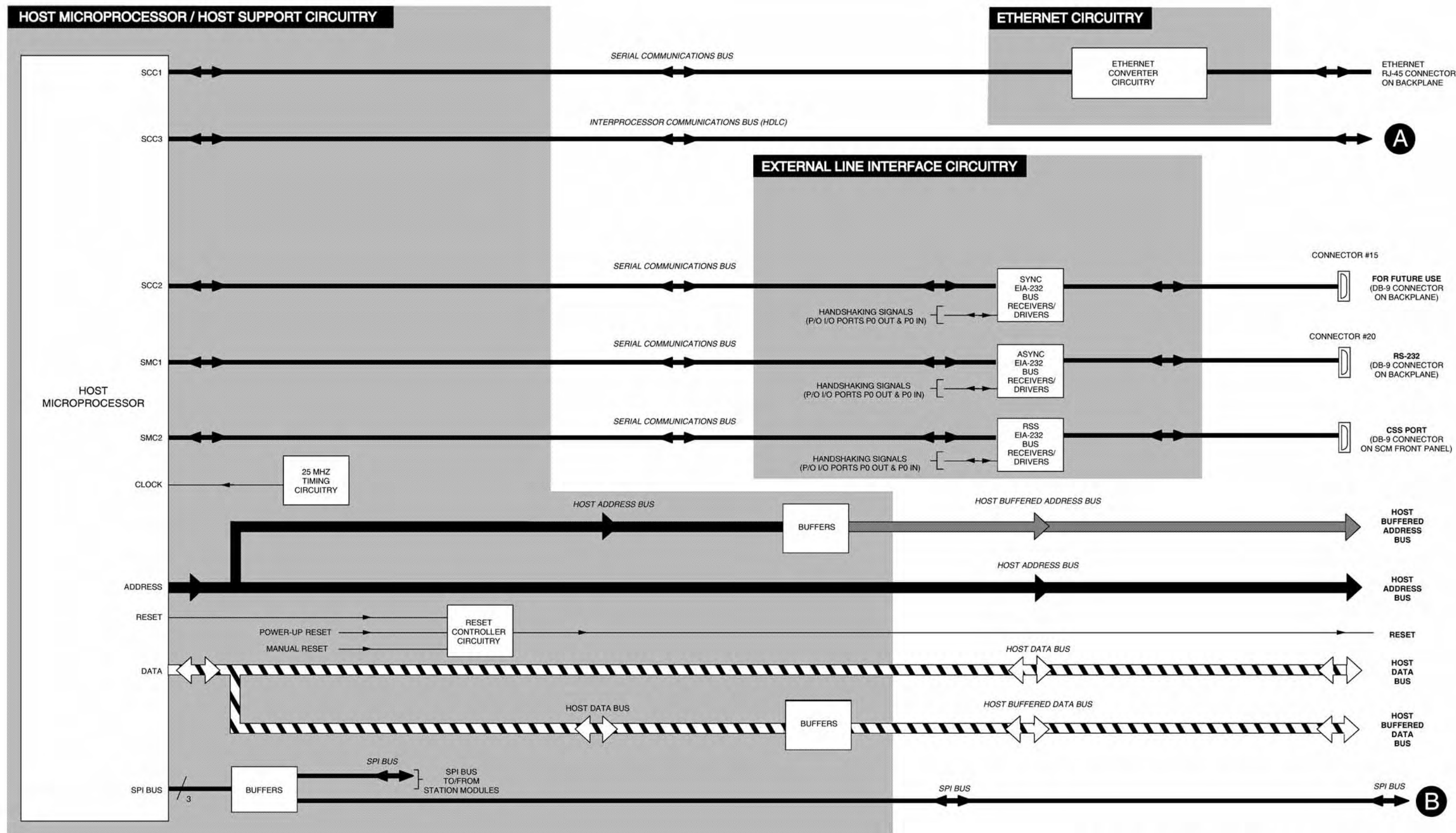

Figure 2 Station Control Board Functional Block Diagram (Sheet 1 of 5)

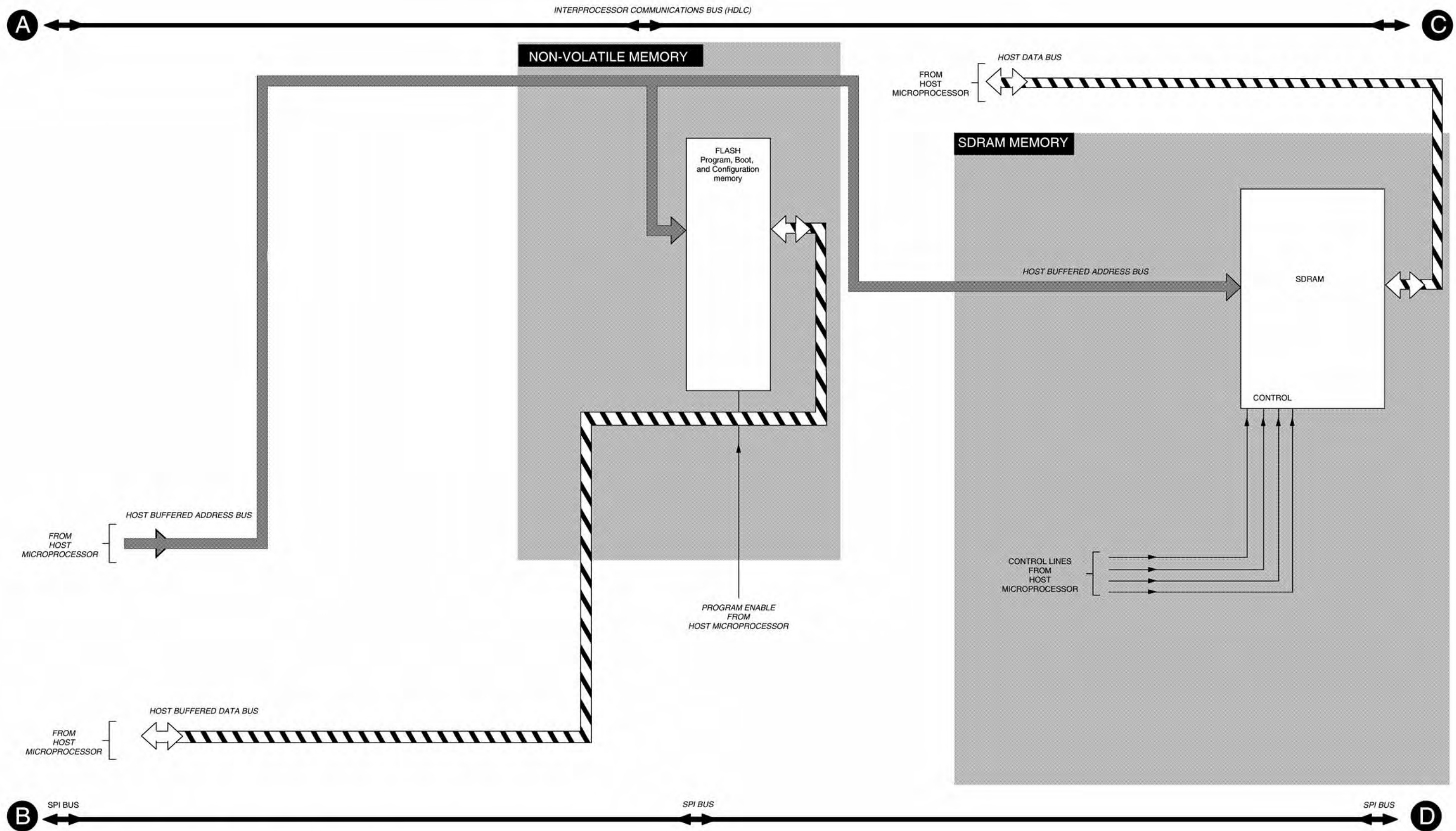

Figure 3 Station Control Board Functional Block Diagram (Sheet 2 of 5)

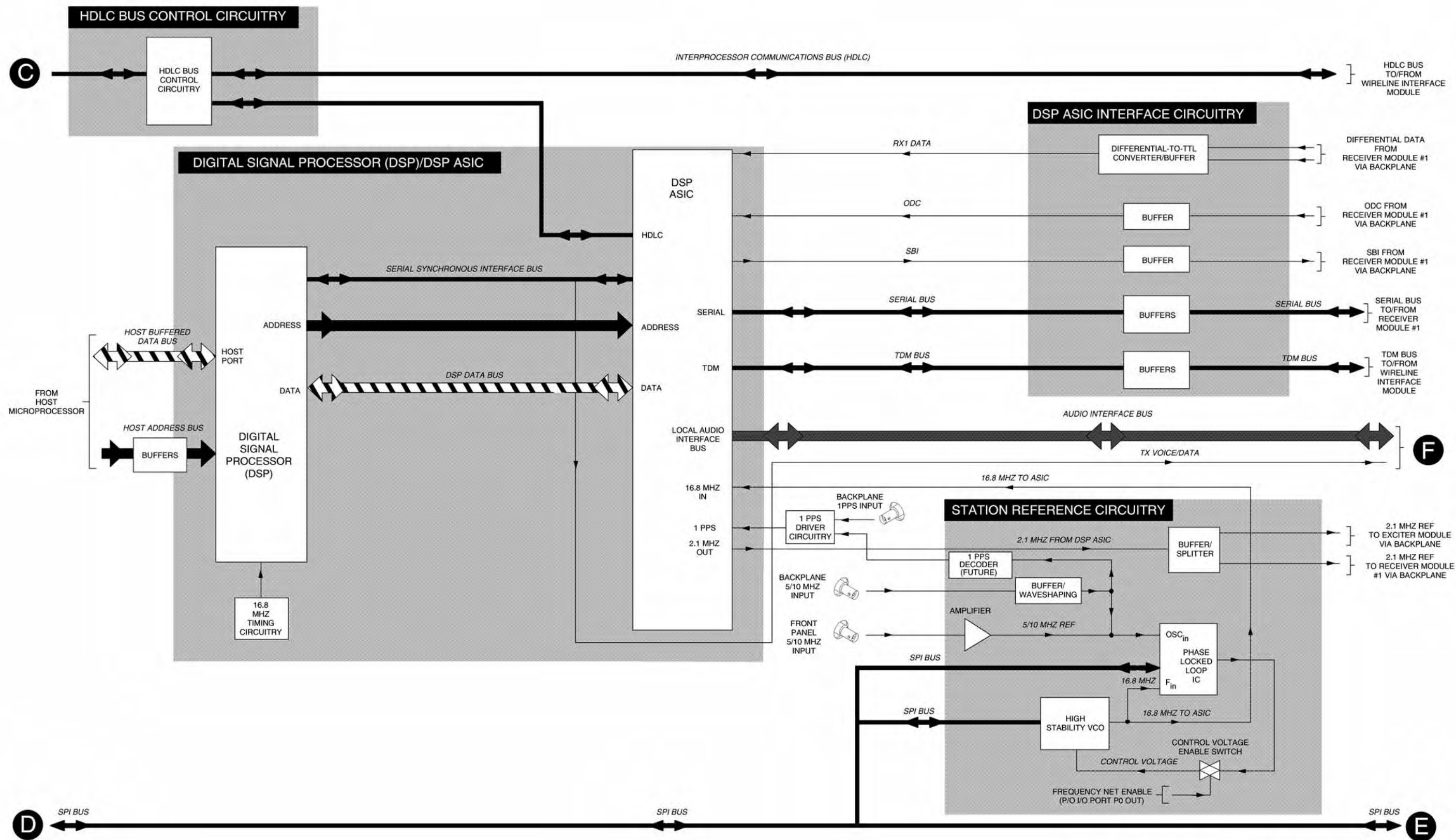

Figure 4 Station Control Board Functional Block Diagram (Sheet 3 of 5)

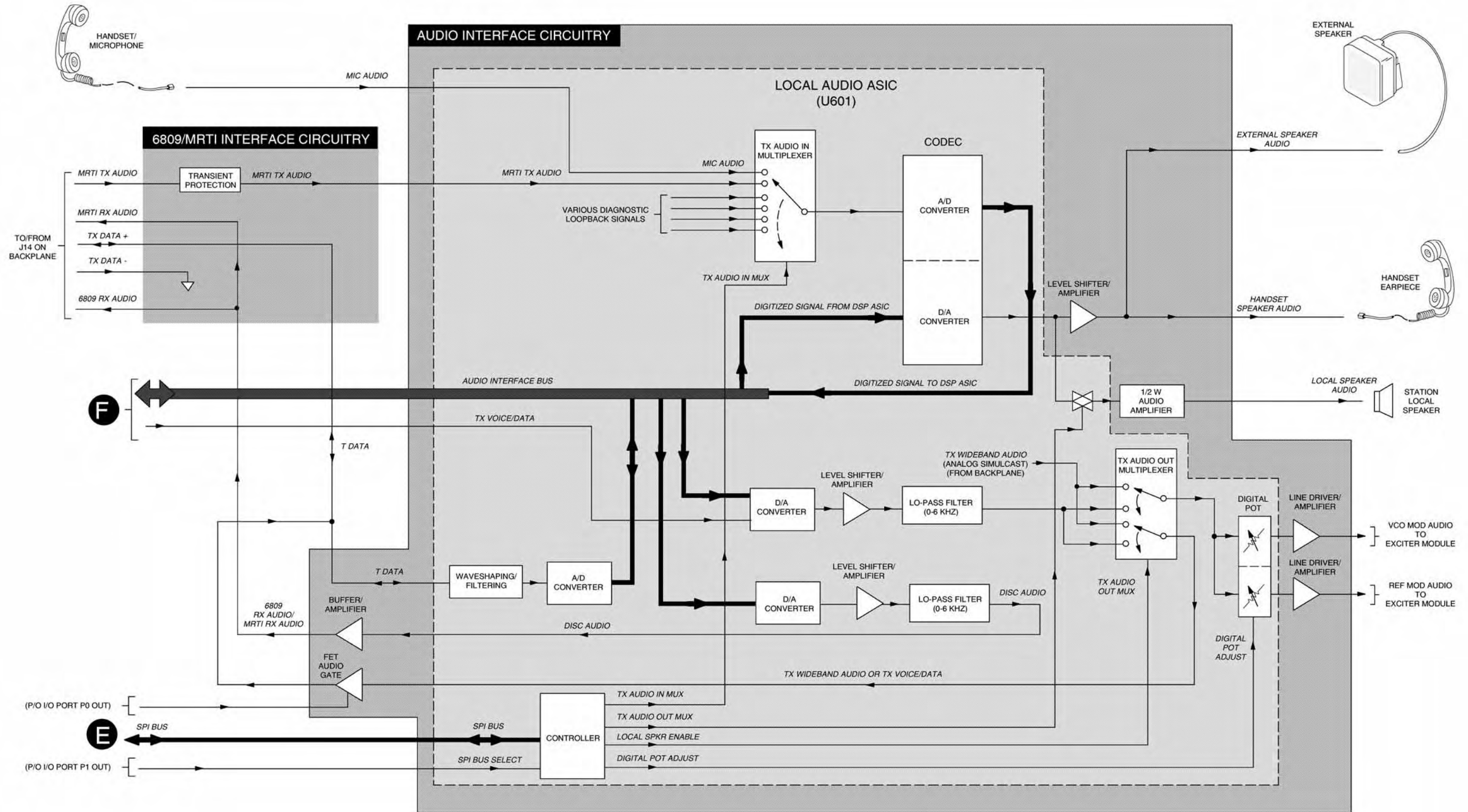

Figure 5 Station Control Board Functional Block Diagram (Sheet 4 of 5)



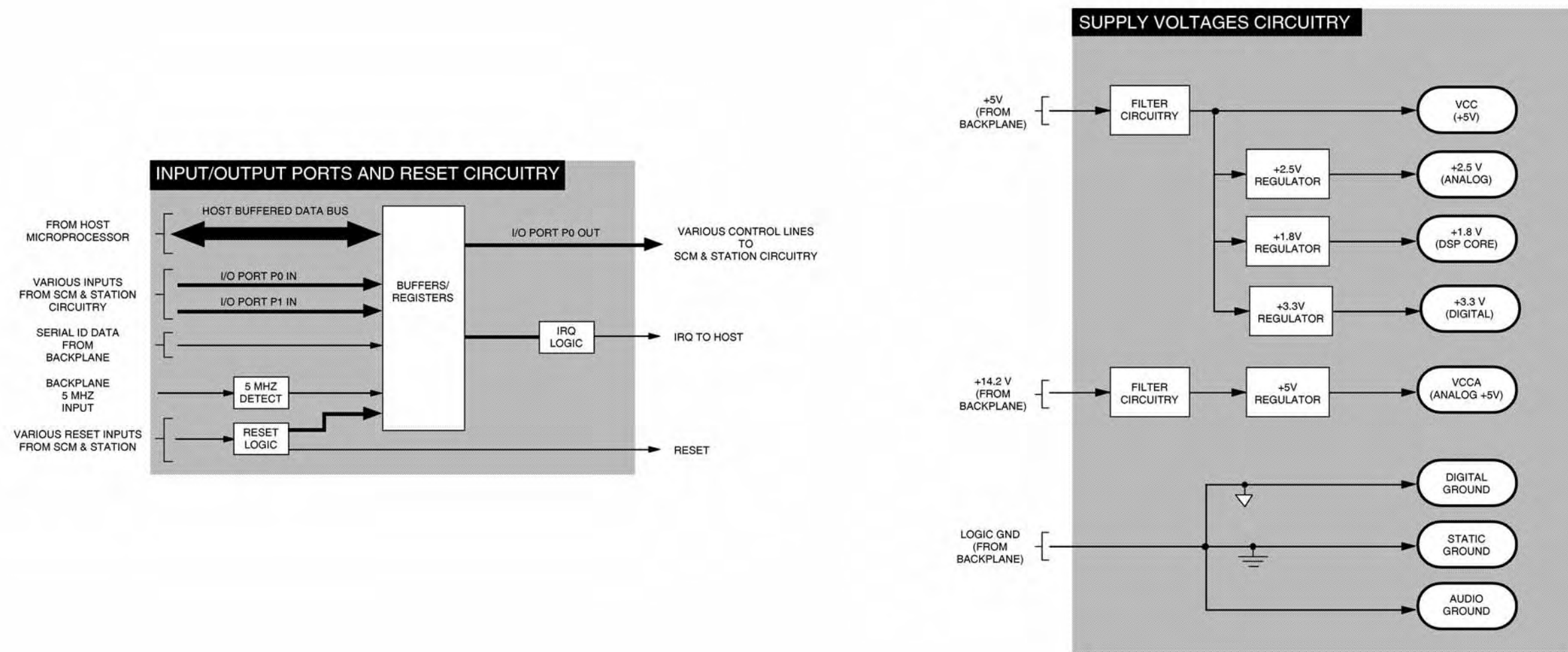

Figure 6 Station Control Board Functional Block Diagram (Sheet 5 of 5)

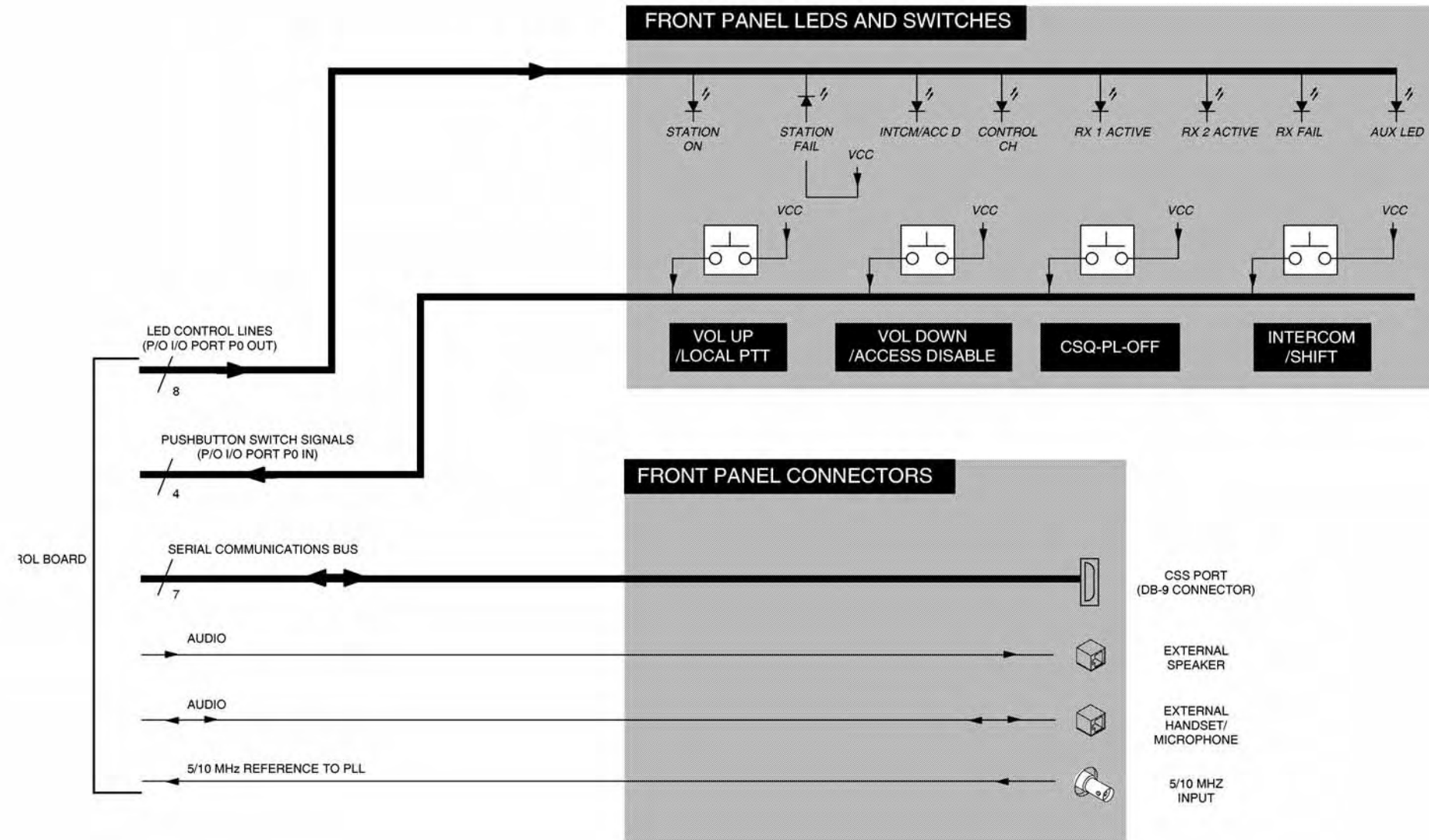

Figure 7 Front Panel LEDs and Switches



# WIRELINE INTERFACE BOARD

MODELS CLN6955D  
CLN6957D

---

---

## 1 DESCRIPTION

The Models CLN6955D and CLN6957D wireline interface boards (WIBs) are described in this section. A general description, identification of jumpers, indicators, and inputs/outputs, functional block diagrams, and functional theory of operation are provided. The information provided is sufficient to give service personnel a functional understanding of the module, allowing maintenance and troubleshooting to the module level. (Refer also to the Maintenance and Troubleshooting section of this manual for detailed troubleshooting procedures for all modules in the station.)

---

### General Description

**Note:** Model CLN6955 WIB is designed for use in stations installed in locations where local codes permit phone line connections to either the 50-pin Telco connector or the orange screw terminal connector. Model CLN6957 allows only connections to the orange screw terminal connector.

The WIB serves as the interface between the customer telephone lines and the station equipment. Each WIB contains circuitry to interface with a variety of telephone line configurations and signal types. In addition, the board contains a connector to accept one modem card. This card is required to interface with an ASTRO 9.6kbps input.

The WIB is installed behind the SCM front panel and connects to the station backplane. Phone line connections may be made either to a 50-pin Telco connector and/or an orange screw terminal connector (see sidebar).

---

### Overview of Circuitry

The WIB contains the following circuitry:

- Audio and Data Circuits — the WIB provides a number of voice and data circuits that interface with the customer phone lines
- Microprocessor ( $\mu$ P) — serves as the main controller for the WIB; communicates with the SCM microprocessor, interfaces with the ASTRO data signals, and provides monitoring and control for a variety of on-board I/O circuits
- Peripheral Application Specific IC (PASIC) — primarily responsible for injecting and retrieving PCM voice signals into/from the time division multiplexing (TDM) bus that connects from the WIB to the SCM
- DC Remote Detection — circuitry provides current sensing and detection for dc remote control of station
- Simulcast Processing Circuitry — circuitry is provided for summing and control of simulcast PL and reverse burst tones

## 2 CONTROLS, INDICATORS, AND INPUTS/OUTPUTS

Figure 1 shows the WIB jumpers, indicators, and all input and output external connections.

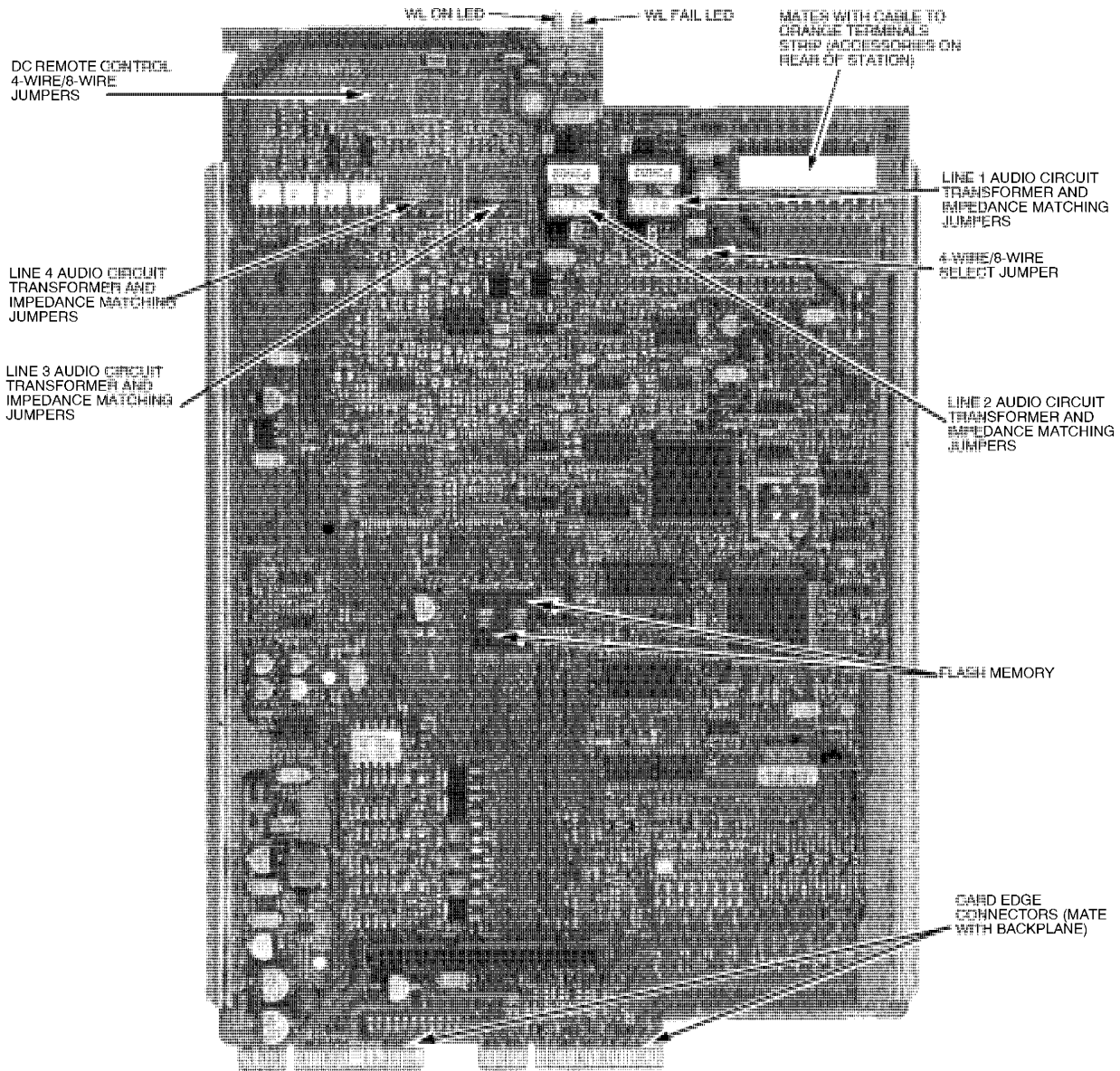

**Figure 1** Wireline Interface Board Jumpers, Indicators, and Inputs/Outputs (CLN6955D Shown)

---

## 3 FUNCTIONAL THEORY OF OPERATION

The following theory of operation describes the operation of the WIB circuitry at a functional level. The information is presented to give the service technician a basic understanding of the functions performed by the module in order to facilitate maintenance and troubleshooting to the module level. Refer to Figure 2 for an overall block diagram of the WIB, and Figure 3 through Figure 5 for block diagrams for 2-wire voice, 4-wire voice, and ASTRO 9.6kbps signal paths.

---

### Functional Overview

#### ***Introduction***

As mentioned previously, the WIB serves as the interface between the customer telephone lines and the station equipment. In general, the WIB processes and routes all voice and/or data signals between the station equipment and the landline equipment such as a control center or modem.

As shown in the block diagram in Figure 2, the WIB contains a  $\mu$ P with RAM and EPROM, a PASIC, one 4-wire audio circuit, and one 2-wire audio circuit. Also provided are a dc remote decoding circuit, Simulcast processing circuitry, and miscellaneous I/O circuits. All of these circuits are described in the following paragraphs.

#### ***Microprocessor Circuitry***

The WIB  $\mu$ P provides overall control of the WIB operation, provides two serial bus links, and communicates with the  $\mu$ P in the SCM.

The WIB operating code and other parameters are stored in two 256k x 8 FLASH ICs. Short term storage is provided by two 128k x 8 RAM ICs.

The  $\mu$ P data bus is connected to each of the PASICs to provide control.

Two serial bus links are provided and managed by the  $\mu$ P. One of these is dedicated to interfacing with a plug-in modem card for ASTRO 9.6kbps applications. The other serial link is used to interface with the microprocessor in the SCM using HDLC protocol.

#### ***Peripheral Application Specific IC (PASIC)***

One PASIC is provided on the WIB to interface with the various audio/data circuits. In general, the PASIC is responsible for accepting either PCM voice information (for 4-wire or 2-wire operation) and routing the information to the proper destination such as from landline to station and from station to landline. Details of the signal paths are provided in *Description of Audio/Data Signal Paths* later in this section.

### ***Audio/Data Circuits***

Each WIB contains circuitry for one 4-wire audio/data circuit, one 2-wire audio/data circuit, and one ASTRO 9.6kbps data circuit. As shown in the block diagram, the PASIC and its associated circuitry function to provide the following signal paths:

- 4-wire voice audio from landline to station, and from station to landline
- 2-wire voice audio from landline to station, and from station to landline
- 9.6kbps (ASTRO) modem data from landline to station, and from station to landline

*Description of Audio/Data Signal Paths* provided later in this section contains block diagrams of each of the major signal paths with an explanation of the signal flows.

### ***DC Remote Detection***

The WIB contains circuitry to monitor the Line 1 Audio and Line 2 Audio input lines and detect dc control currents. The detection outputs ( $\pm 12.5\text{mA}$ ,  $\pm 5.5\text{mA}$ ,  $+2.5\text{mA}$ , and  $-2.5\text{mA}$ ) are dc voltages (nominally either  $+7\text{V}$  or  $+5\text{V}$ ) that are fed to an A/D converter. The converter serves as a comparator and interprets the inputs as highs and lows. The data is then sent serially to the  $\mu\text{P}$ .

### ***Miscellaneous Inputs/Outputs***

The following inputs and outputs are provided on the WIB. These lines may be assigned various functions according to customer specifications.

- One (1) optically-coupled input
- Seven (7) transistor-coupled inputs
- One (1) relay closure output (normally open contact)
- Three (3) transistor-coupled outputs

### ***Simulcast Processing Circuitry***

Summing and gating circuitry is provided on the WIB to allow PL tones, reverse burst, and TX audio (GEN TX DATA) to be combined and output to the VCO in the exciter module (after signal processing by the SCM) to directly modulate the rf carrier. The simulcast circuitry is controlled by the SCM  $\mu\text{P}$  via the WIB  $\mu\text{P}$  and the PASIC on the WIB.

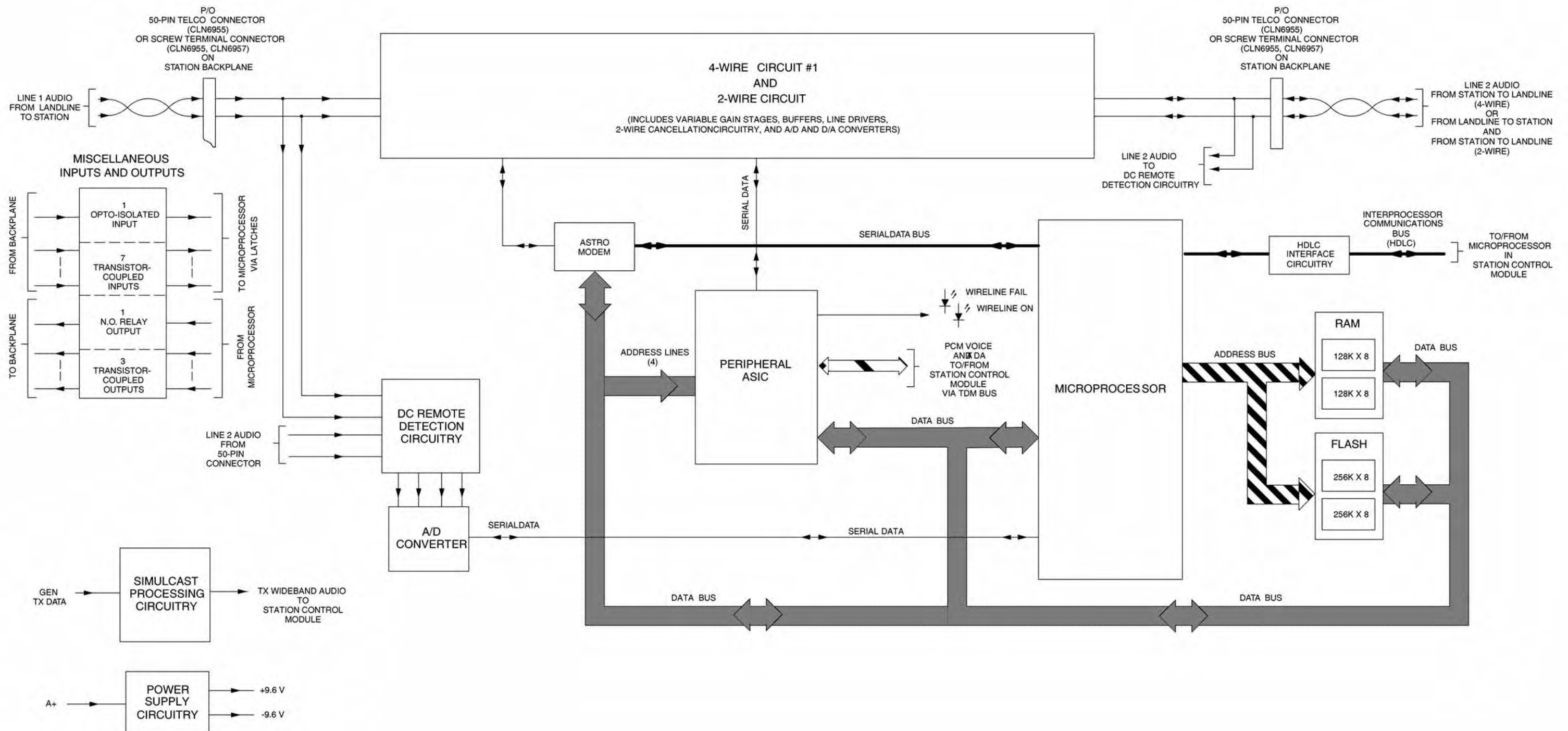
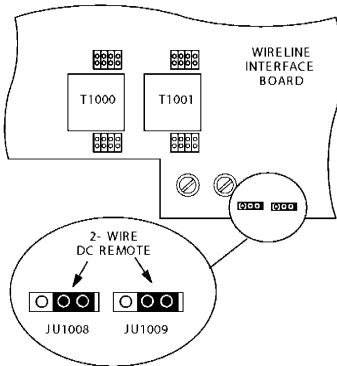

Figure 2 CLN6955D / CLN6957D Wireline Interface Board Functional Block Diagram

## Description of Audio/Data Signal Paths

**Note:** Depending on local codes and/or customer preference, phone line connections may be made at either the 50-pin Telco connector or the screw terminal connector on the station backplane. 2-wire audio connections are made at Line 2 Audio.

For systems using dc remote control, set jumpers JU1008 and JU1009 as shown below for 2-wire applications:



Four levels of gain adjustment are provided by circuitry on the WIB for Landline-to-Station and Station-to-Landline audio paths. Additional fine level adjustments are performed in software in the SCM.

(Note that a sample of the outbound signal is fed from one of the output transistors to the cancellation amplifier in the landline to station circuitry. This signal is used to cancel the outbound signal and allow the inbound signal to pass through the landline to station circuitry.)

### 2-Wire Voice Audio Path (Refer to Figure 3)

Voice audio signals sent to/from the station via 2-wire copper pair are processed by the 2-wire audio circuit on the WIB (line 2 audio). The audio transformer in this circuit may have both inbound and outbound audio signals present simultaneously, and therefore employs circuitry to pass audio in each direction while cancelling the alternate signal. The 2-wire audio circuit operates as follows:

**Landline to Station** balanced audio is input to the primary of an audio transformer. The signal is induced into the transformer secondary and fed to an amplifier. [Note that jumper fields in parallel with both the primary and secondary coils provide for selectable impedance matching. Refer to the illustration below for impedance setting information.]

The amplifier sums the inbound and outbound signals and feeds one input to the cancellation amplifier. The other input to this amplifier is the output signal only. A cancellation of the outbound signal results, and the output from this amplifier is the inbound signal only. The signal is fed to a buffer (through jumper JU1010 placed in the 2-wire position, as shown in the figure at the top of the next page) that feeds the gain adjust circuitry. Under control of the PASIC, the gain control circuitry provides eight levels of gain adjust: 5, 10, 15, 20, 25, 30, 35, and 40 dB.

The output of the gain adjust circuitry is fed to an A/D converter that digitizes the audio signal into a PCM output. The PCM output is fed serially to the PASIC, which places the data in the proper TDM timeslot (as instructed by the  $\mu$ P in the SCM) and output to the SCM on the TDM Bus.

**Station to Landline** audio is input to the PASIC in the form of PCM data on the TDM bus. The PASIC extracts the data and feeds it to a D/A converter that takes the PCM data and converts it to an analog audio signal. The audio signal is fed to the gain adjust circuitry. Under control of the PASIC, the gain control circuitry provides four levels of gain adjust: 0dB, -6dB, -12dB, and -18dB.

The output of the gain adjust circuitry is fed through a 2-pole low-pass filter and into the inputs of two amplifiers. The outputs of the amplifiers are fed to two transistors that are connected in a push-pull configuration to drive the primary of an audio transformer. The audio signal is induced into the secondary and output to the landline system (via either the 50-pin Telco connector or screw terminal connector) as balanced audio.



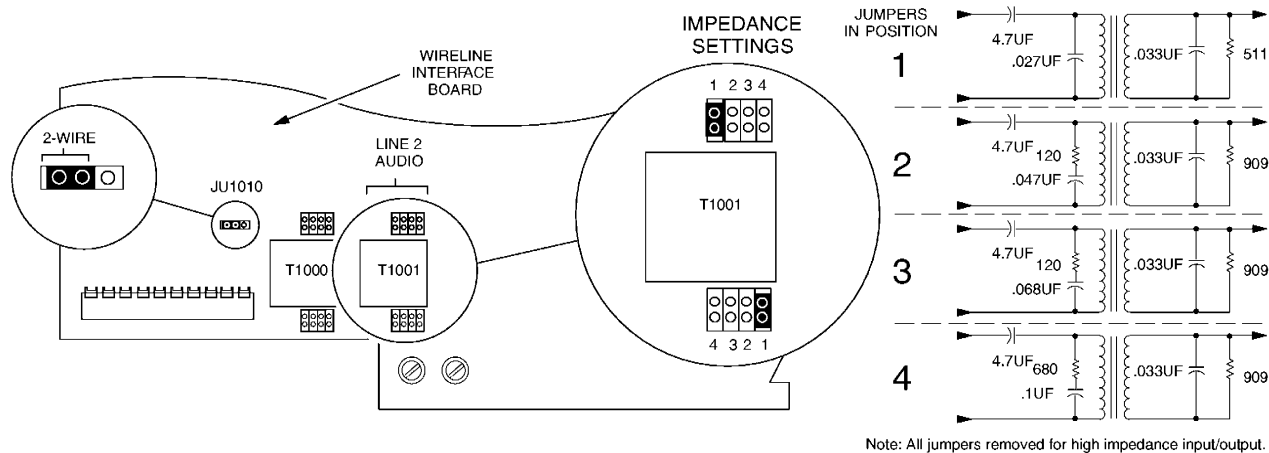

**Note:** Depending on local codes and/or customer preference, phone line connections may be made at either the 50-pin Telco connector or the screw terminal connector on the station backplane. Landline to Station signals are connected at Line 1 Audio. Station to Landline signals are connected at Line 2 Audio.

For systems using dc remote control, set jumpers JU1008 and JU1009 as shown below for 4-wire applications::

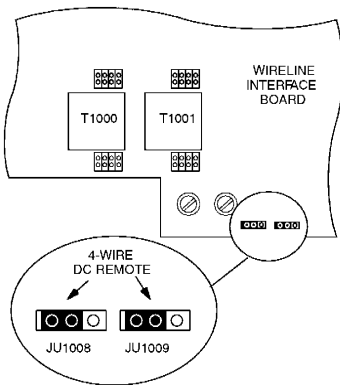

Four levels of gain adjustment are provided by circuitry on the WIB for Landline-to-Station and Station-to-Landline audio paths. Additional fine level adjustments are performed in software in the SCM.

### 4-Wire Voice Audio Path (Refer to Figure 4)

Voice audio signals sent to/from the station via 4-wire copper pairs are processed by the 4-wire audio circuit on the WIB (line 1 audio & line 2 audio). The 4-wire circuit operates as follows:

**Landline to Station** balanced audio is input to the primary of an audio transformer. The signal is induced into the transformer secondary and fed to a buffer (through jumper JU1010 placed in the 4-wire position, as shown below). [Note that jumper fields in parallel with both the primary and secondary coils provide for selectable impedance matching. Refer to the figure at the top of the next page for impedance setting information.]

The buffer output is fed to the gain adjust circuitry. Under control of the PASIC, the gain control circuitry provides eight levels of gain adjust: 5, 10, 15, 20, 25, 30, 35, and 40 dB.

The output of the gain adjust circuitry is fed to an A/D converter that digitizes the audio signal into a PCM output. This output is fed serially to the PASIC, which places the data in the proper TDM timeslot (as instructed by the  $\mu P$  in the SCM) and output to the SCM on the TDM Bus.

**Station to Landline** audio is input to the PASIC in the form of PCM data on the TDM bus. The PASIC extracts the data and feeds it to a D/A converter that takes the PCM data and converts it to an analog audio signal. The audio signal is fed to the gain adjust circuitry. Under control of the PASIC, the gain control circuitry provides four levels of gain adjust: 0dB, -6dB, -12dB, and -18dB.

The output of the gain adjust circuitry is fed through a 2-pole low-pass filter and into the inputs of two amplifiers. The outputs of the amplifiers are fed to two transistors that are connected in a push-pull configuration to drive the primary of an audio transformer. The audio signal is induced into the secondary and output to the landline system (via either the 50-pin Telco connector or screw terminal connector) as balanced audio.

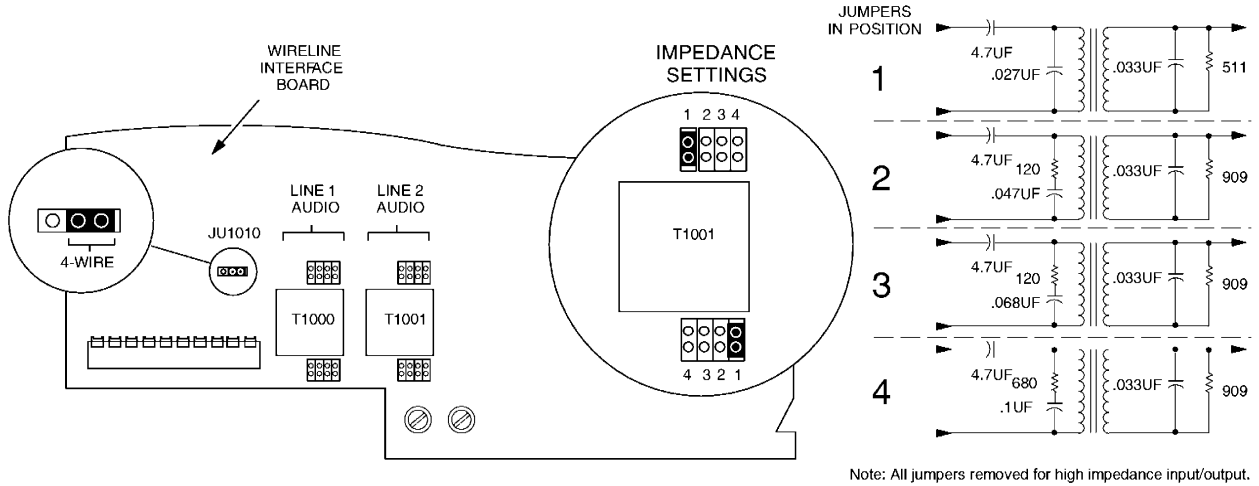

**Note:** Depending on local codes and/or customer preference, phone line connections may be made at either the 50-pin Telco connector or the screw terminal connector on the station backplane. Landline to Station signals are connected at Line 1 Audio. Station to Landline signals are connected at Line 2 Audio.

The WIB is equipped with a connector to accept a plug-in ASTRO modem card.

**9.6KBPS (ASTRO) Modem Data Path (Refer to Figure 5)**

9.6kbps (ASTRO) modem data signals are sent to/from the station via 4-wire copper pairs and are processed by the 4-wire audio circuit on the WIB (line 1 audio & line 2 audio). The 4-wire circuit operates as follows:

**Landline to Station** modem data is input to the primary of an audio transformer as balanced audio. The signal is induced into the transformer secondary and fed to a buffer (through jumper JU1010 placed in the 4-wire position, as shown at the top of this page). [Note that jumper fields in parallel with both the primary and secondary coils provide for selectable impedance matching. Refer to the illustration above for impedance setting information.]

The buffer output is fed to a modem (a separate card that plugs into the WIB) that converts the modem signal to detected data. The data signal is then fed to the  $\mu P$  over a serial bus. The  $\mu P$  sends the data to the  $\mu P$  in the SCM over an interprocessor communications bus (HDLC protocol).

**Station to Landline** modem data is input to the  $\mu P$  from the SCM  $\mu P$  via the interprocessor communications bus (HDLC protocol). The  $\mu P$  feeds the data to the modem that converts the data to a modem signal.

The output of the modem is fed to the gain adjust circuitry. Under control of the PASIC, the gain control circuitry provides four levels of gain adjust: 0dB, -6dB, -12dB, and -18dB.

The output of the gain adjust circuitry is fed through a 2-pole low-pass filter and into the inputs of two amplifiers. The outputs of the amplifiers are fed to two transistors that are connected in a push-pull configuration to drive the primary of an audio transformer. The modem data signal is induced into the secondary and output to the landline system (via either the 50-pin Telco connector or screw terminal connector) as balanced audio.

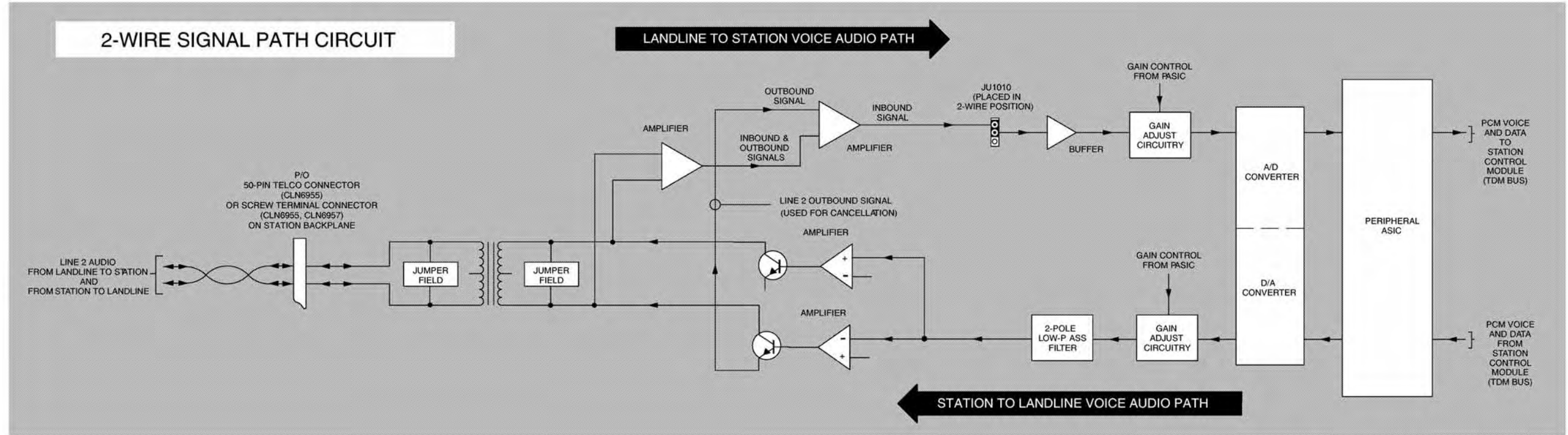

Figure 3 2-Wire Voice Audio Path Functional Block Diagram

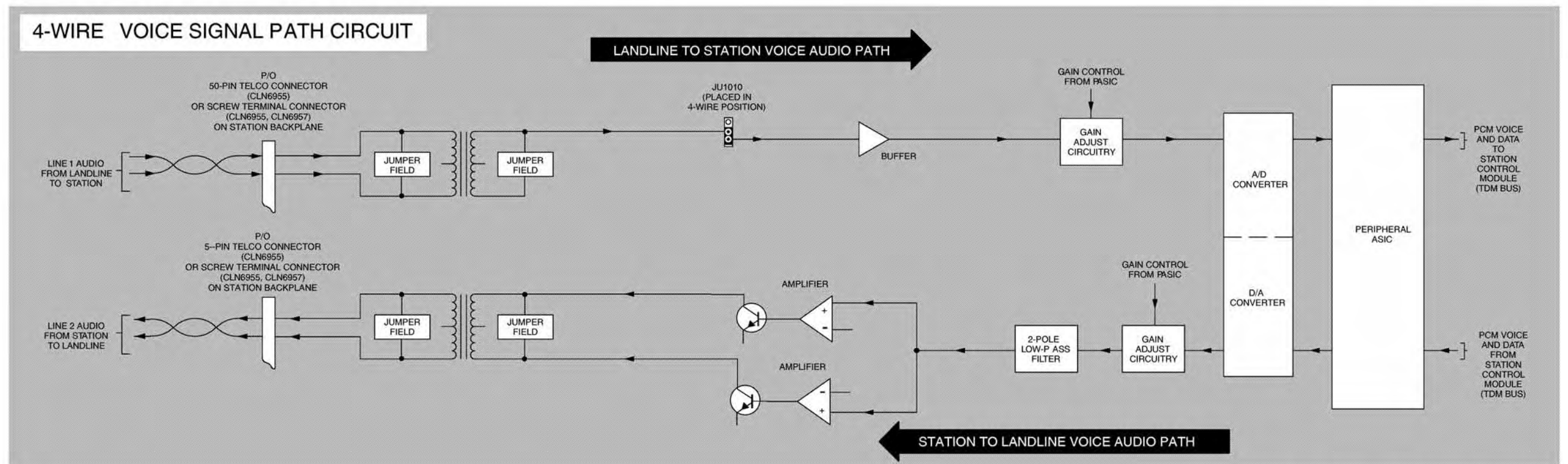

Figure 4 4-Wire Voice Audio Path Functional Block Diagram

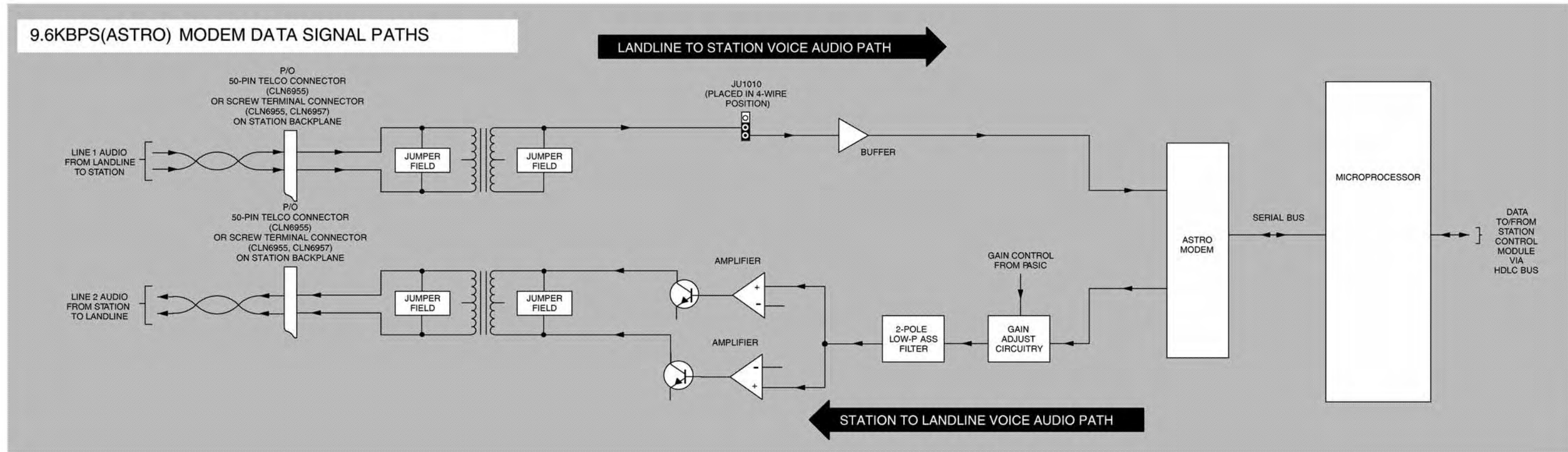

Figure 5 9.6kbps (ASTRO) Modem Data Signal Path Functional Block Diagram

---

---

## 1 DESCRIPTION

The Models CLN6956D and CLN6958D wireline interface boards (WIBs) are described in this section. A general description, identification of jumpers, indicators, and inputs/outputs, functional block diagrams, and functional theory of operation are provided. The information provided is sufficient to give service personnel a functional understanding of the module, allowing maintenance and troubleshooting to the module level. (Refer also to the *Maintenance and Troubleshooting* section of this manual for detailed troubleshooting procedures for all modules in the station.)

---

### General Description

**Note:** Model CLN6956 WIB is designed for use in stations installed in locations where local codes permit phone line connections to either the 50-pin Telco connector or the orange screw terminal connector. Model CLN6958 allows only connections to the orange screw terminal connector.

The WIB serves as the interface between the customer telephone lines and the station equipment. Each WIB contains circuitry to interface with a variety of telephone line configurations and signal types. In addition, the board contains connectors to accept two modem cards. These cards are required to interface with up to two ASTRO 9.6kbps inputs.

The WIB is installed behind the station control module (SCM) front panel and connects to the station backplane. Phone line connections may be made either to a 50-pin Telco connector and/or an orange screw terminal connector (see sidebar).

---

### Overview of Circuitry

The WIB contains the following circuitry:

- Audio and Data Circuits — the WIB provides a number of voice and data circuits which interface with the customer phone lines
- Microprocessor ( $\mu$ P) — serves as the main controller for the WIB; communicates with the SCM  $\mu$ P, interfaces with the ASTRO data signals, and provides monitoring and control for a variety of on-board I/O circuits
- Peripheral Application Specific IC (PASIC) — primarily responsible for injecting and retrieving PCM voice signals into/from the time division multiplex (TDM) bus that connects from the WIB to the SCM
- DC Remote Detection — circuitry provides current sensing and detection for dc remote control of station

- Simulcast Processing Circuitry — circuitry is provided for summing and control of simulcast PL and reverse burst tones

## 2 CONTROLS, INDICATORS, AND INPUTS/OUTPUTS

Figure 1 shows the WIB jumpers, indicators, and all input and output external connections.

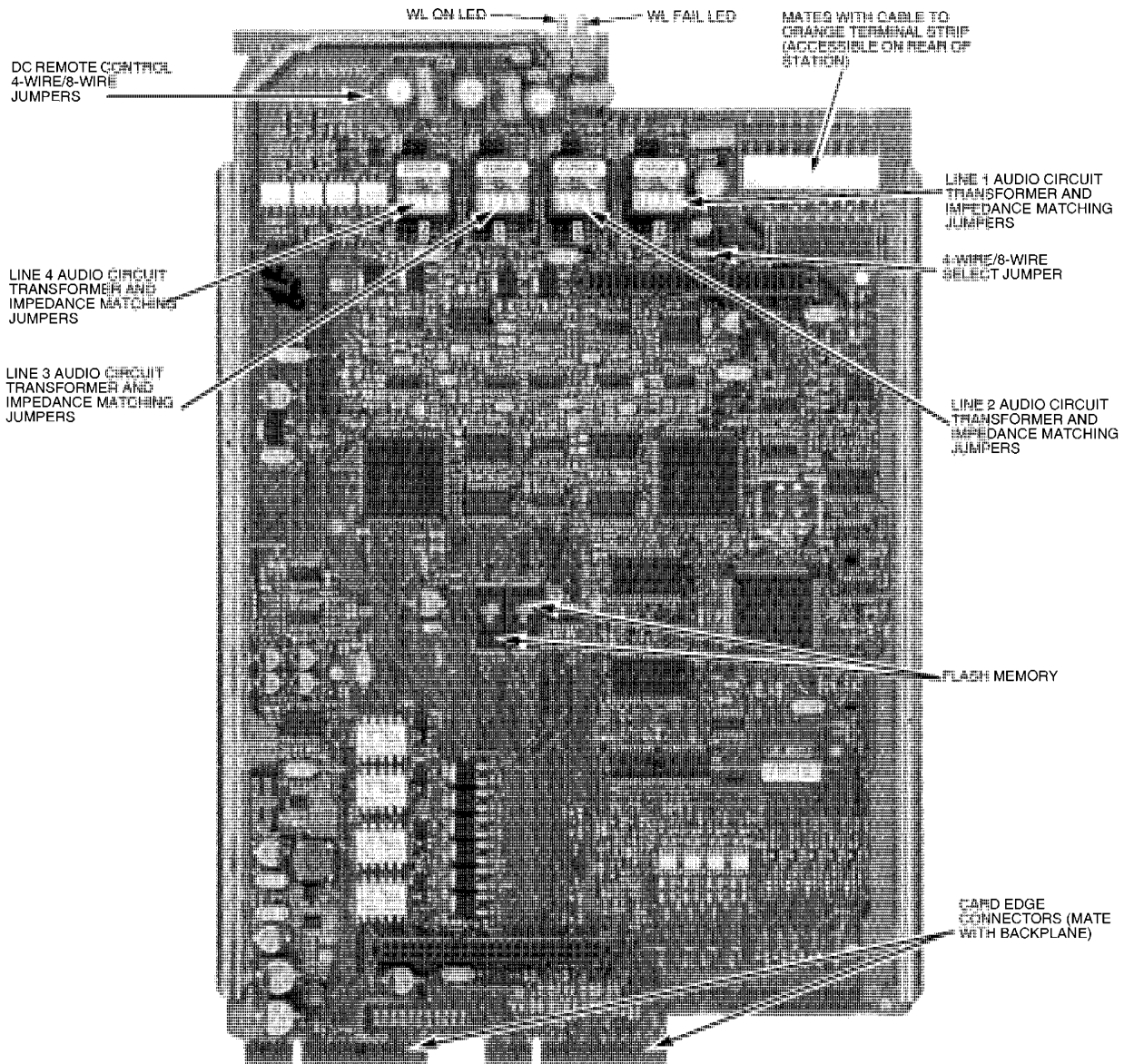

**Figure 1** Wireline Interface Board Jumpers, Indicators, and Inputs/Outputs (CLN6956D Shown)

---

## 3 FUNCTIONAL THEORY OF OPERATION

The following theory of operation describes the operation of the WIB circuitry at a functional level. The information is presented to give the service technician a basic understanding of the functions performed by the module in order to facilitate maintenance and troubleshooting to the module level. Refer to Figure 2 for an overall block diagram of the WIB, and Figure 3 through Figure 5 for block diagrams for 2-wire voice, 4-wire voice, and 9.6kbps (ASTRO) signal paths.

---

### Functional Overview (Refer to Figure 2)

#### *Introduction*

As mentioned previously, the WIB serves as the interface between the customer telephone lines and the station equipment. In general, the WIB processes and routes all voice and/or data signals between the station equipment and the landline equipment such as a control center or modem.

As shown in the block diagram in Figure 2, the WIB contains a  $\mu$ P with RAM and EPROM, a peripheral application specific IC (PASIC), one 4-wire audio circuit, and one 2-wire audio circuit. Also provided are a dc remote decoding circuit, simulcast processing circuitry, and miscellaneous I/O circuits. These circuits are described in the following paragraphs.

#### *Microprocessor Circuitry*

The WIB  $\mu$ P provides overall control of the WIB operation, provides two serial bus links, and communicates with the  $\mu$ P in the SCM.

The WIB operating code and other parameters are stored in two 256k x 8 FLASH ICs. Short term storage is provided by two 128k x 8 RAM ICs.

The  $\mu$ P data bus is connected to each of the PASICs to provide control.

Two serial bus links are provided and managed by the  $\mu$ P. One of these is dedicated to interfacing with a plug-in modem card for ASTRO 9.6kbps applications. The other serial link is used to interface with the  $\mu$ P in the SCM using HDLC protocol.

#### *Peripheral Application Specific IC (PASIC)*

One PASIC is provided on the WIB to interface with the various audio/data circuits. In general, the PASIC is responsible for accepting either PCM voice information (for 4-wire or 2-wire operation) and routing the information to the proper destination, such as from landline to station and from station to landline. Details of the signal paths are provided in *Description of Audio/Data Signal Paths* later in this section.

### ***Audio/Data Circuits***

Each WIB contains circuitry for one 4-wire audio/data circuit, one 2-wire audio/data circuit, and one ASTRO 9.6kbps data circuit. As shown in the block diagram, the PASIC and its associated circuitry function to provide the following signal paths:

- 4-wire voice audio from landline to station, and from station to landline
- 2-wire voice audio from landline to station, and from station to landline
- ASTRO 9.6kbps modem data from landline to station, and from station to landline

*Description of Audio/Data Signal Paths* provided later in this section contains block diagrams of each of the major signal paths with an explanation of the signal flows.

### ***DC Remote Detection***

The WIB contains circuitry to monitor the line 1 audio and line 2 audio input lines and detect dc control currents. The detection outputs ( $\pm 12.5$  mA,  $\pm 5.5$  mA,  $+2.5$  mA, and  $-2.5$  mA) are dc voltages (nominally either  $+7$ V or  $+5$ V) which are fed to an A/D converter. The converter serves as a comparator and interprets the inputs as highs and lows. The data is then sent serially to the  $\mu$ P.

### ***Miscellaneous Inputs/Outputs***

The following inputs and outputs are provided on the WIB. These lines may be assigned various functions according to customer specifications.

- One (1) optically-coupled input
- Seven (7) transistor-coupled inputs
- One (1) relay closure output (normally open contacts)
- Three (3) transistor-coupled outputs

### ***Simulcast Processing Circuitry***

Summing and gating circuitry is provided on the WIB to allow PL tones, reverse burst, and TX audio (GEN TX DATA) to be combined and output to the VCO in the exciter module (after signal processing by the SCM) to directly modulate the rf carrier. The simulcast circuitry is controlled by the SCM  $\mu$ P via the WIB microprocessor ( $\mu$ P) and upper PASIC on the WIB.



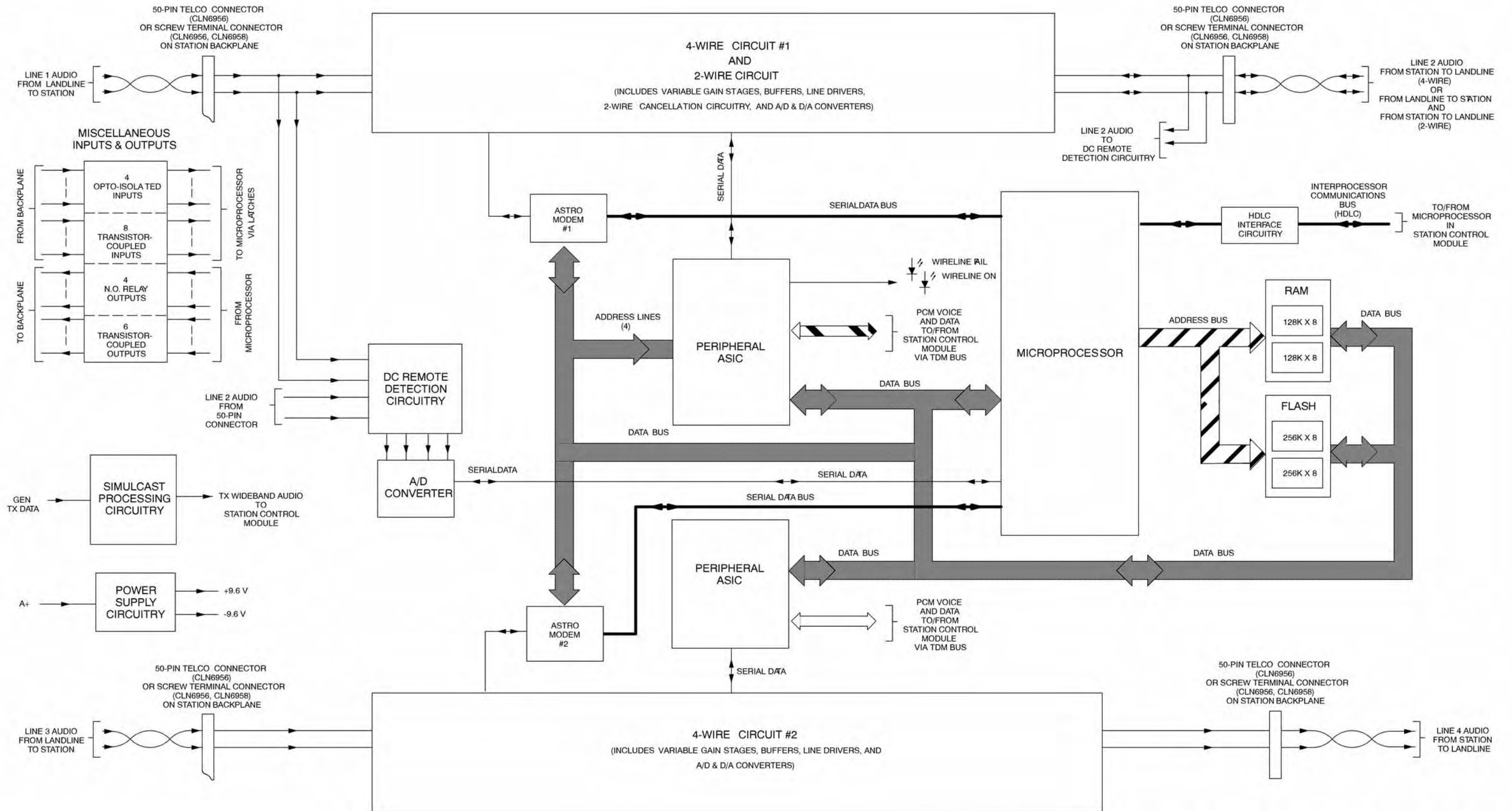
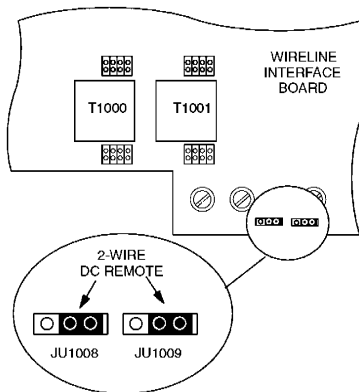

Figure 2 CLN6955D / CLN6957D Wireline Interface Board Functional Block Diagram

## Description of Audio/Data Signal Paths

**Note:** Depending on local codes and/or customer preference, phone line connections may be made at either the 50-pin Telco connector or the screw terminal connector on the station backplane. 2-wire audio connections are made at Line 2 Audio.

For systems using dc remote control, set jumpers JU1008 and JU1009 as shown below for 2-wire applications:



Four levels of gain adjustment are provided by circuitry on the WIB for Landline-to-Station and Station-to-Landline audio paths. Additional fine level adjustments are performed in software in the SCM.

(Note that a sample of the outbound signal is fed from one of the output transistors to the cancellation amplifier in the landline to station circuitry. This signal is used to cancel the outbound signal and allow the inbound signal to pass through the landline to station circuitry.)

### 2-Wire Voice Audio Path (Refer to Figure 3)

Voice audio signals sent to/from the station via 2-wire copper pair are processed by the 2-wire audio circuit on the WIB (Line 2 Audio). The audio transformer in this circuit may have both inbound and outbound audio signals present simultaneously, and therefore employs circuitry to pass audio in each direction while cancelling the alternate signal. The 2-wire audio circuit operates as follows:

**Landline to Station** balanced audio is input to the primary of an audio transformer. The signal is induced into the transformer secondary and fed to an amplifier. [Note that jumper fields in parallel with both the primary and secondary coils provide for selectable impedance matching. Refer to the illustration at the top of the following page for impedance setting information.]

The amplifier sums the inbound and outbound signals and feeds one input to the cancellation amplifier. The other input to this amplifier is the output signal only. A cancellation of the outbound signal results, and the output from this amplifier is the inbound signal only. The signal is fed to a buffer through jumper JU1010 placed in the 2-wire position, as shown in the figure at the top of the following page, which feeds the gain adjust circuitry. Under control of the PASIC, the gain control circuitry provides eight levels of gain adjust: 5, 10, 15, 20, 25, 30, 35, and 40 dB.

The output of the gain adjust circuitry is fed to an A/D converter, which digitizes the audio signal into a PCM output. This output is fed serially to the PASIC, which places the data in the proper TDM timeslot (as instructed by the microprocessor in the SCM) and output to the SCM on the TDM Bus.

**Station to Landline** audio is input to the PASIC in the form of PCM data on the TDM bus. The PASIC extracts the data and feeds it to a D/A converter which converts the PCM data to an analog audio signal. The audio signal is fed to the gain adjust circuitry. Under control of the PASIC, the gain control circuitry provides four levels of gain adjust: 0dB, -6dB, -12dB, and -18dB.

The output of the gain adjust circuitry is fed through a 2-pole low-pass filter and into the inputs of two amplifiers. The outputs of the amplifiers are fed to two transistors which are connected in a push-pull configuration to drive the primary of an audio transformer. The audio signal is induced into the secondary and output to the landline system (via either the 50-pin Telco connector or screw terminal connector) as balanced audio.

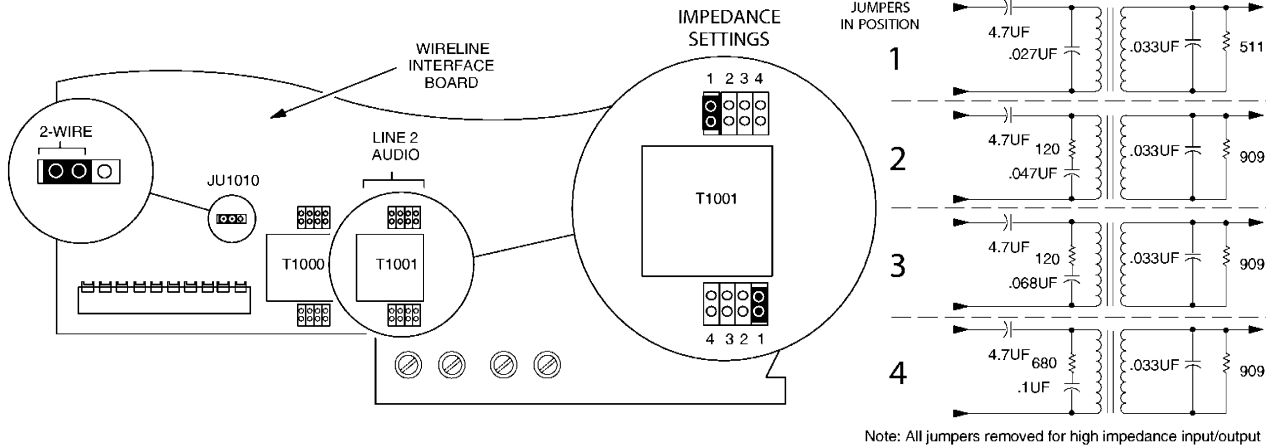

**Note:** Depending on local codes and/or customer preference, phone line connections may be made at either the 50-pin Telco connector or the screw terminal connector on the station backplane. Landline to Station signals are connected at Line 1 Audio or Line 3 Audio. Station to Landline signals are connected at Line 2 Audio or Line 4 Audio.

For systems using dc remote control, set jumpers JU1008 and JU1009 as shown below for 4-wire applications:

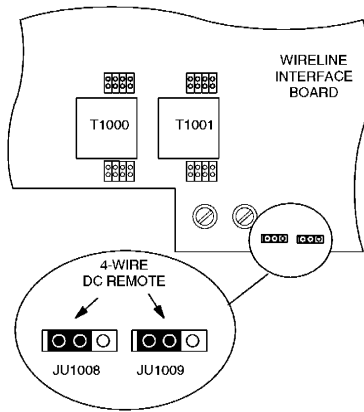

Four levels of gain adjustment are provided by circuitry on the WIB for Landline-to-Station and Station-to-Landline audio paths. Additional fine level adjustments are performed in software in the SCM.

### 4-Wire Voice Audio Path (Refer to Figure 4)

Voice audio signals sent to/from the station via 4-wire copper pairs are processed by one of two 4-wire audio circuits on the WIB:

- Line 1 Audio & Line 2 Audio
- Line 3 Audio & Line 4 Audio

Both 4-wire circuits operate identically as follows:

**Landline to Station** balanced audio is input to the primary of an audio transformer. The signal is induced into the transformer secondary and fed to a buffer, through jumper JU1010 placed in the 4-wire position, as shown in the figure at the top of the following page. [Note that jumper fields in parallel with both the primary and secondary coils provides for selectable impedance matching. Refer to the figure at the top of the following page for impedance setting information.]

The buffer output is fed to the gain adjust circuitry. Under control of the PASIC, the gain control circuitry provides eight levels of gain adjust: 5, 10, 15, 20, 25, 30, 35, and 40dB.

The output of the gain adjust circuitry is fed to an A/D converter, which digitizes the audio signal into a PCM output. This output is fed serially to the PASIC, which places the data in the proper TDM timeslot (as instructed by the microprocessor in the SCM) and output to the SCM on the TDM Bus.

**Station to Landline** audio is input to the PASIC in the form of PCM data on the TDM bus. The PASIC extracts the data and feeds it to a D/A converter which converts PCM data to an analog audio signal. The audio signal is fed to the gain adjust circuitry. Under control of the PASIC, the gain control circuitry provides four levels of gain adjust: 0dB, -6dB, -12dB, and -18dB.

The output of the gain adjust circuitry is fed through a 2-pole low-pass filter and into the inputs of two amplifiers. The outputs of the amplifiers are fed to two transistors which are connected in a push-pull configuration to drive the primary of an audio transformer. The audio signal is induced into the secondary and output to the landline system

(via either the 50-pin Telco connector or screw terminal connector) as balanced audio.

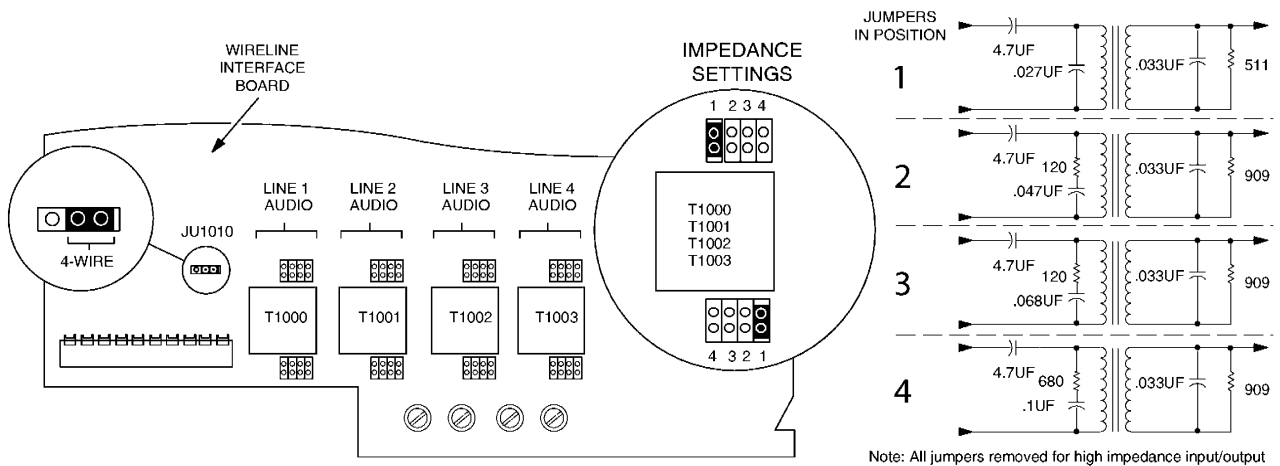

### 9.6KBPS (ASTRO) Modem Data Path (Refer to Figure 5)

9.6kbps (ASTRO) modem data signals are sent to/from the station via 4-wire copper pairs and are processed by one of two 4-wire audio circuits on the WIB:

- Line 1 Audio & Line 2 Audio
- Line 3 Audio & Line 4 Audio

Both 4-wire circuits operate identically as follows:

**Landline to Station** modem data is input to the primary of an audio transformer as balanced audio. The signal is induced into the transformer secondary and fed to a buffer (through jumper JU1010 placed in the 4-wire position, as shown at the top of this page). [Note that jumper fields in parallel with both the primary and secondary coils provide for selectable impedance matching. Refer to the illustration at the top of this page for impedance setting information.]

The buffer output is fed to a modem (a separate card which plugs into the WIB) which converts the modem signal to detected data. The data signal is then fed to the microprocessor over a serial bus. The microprocessor sends the data to the microprocessor in the SCM over an interprocessor communications bus (HDLC protocol).

**Station to Landline** modem data is input to the microprocessor from the SCM microprocessor via the interprocessor communications bus (HDLC protocol). The microprocessor feeds the data to the modem which converts the data to a modem signal.

The output of the modem is fed to the gain adjust circuitry. Under control of the PASIC, the gain control circuitry provides four levels of gain adjust (0dB, -6dB, -12dB, and -18dB).

The output of the gain adjust circuitry is fed through a 2-pole low-pass filter and into the inputs of two amplifiers. The outputs of the amplifiers

**Note:** Depending on local codes and/or customer preference, phone line connections may be made at either the 50-pin Telco connector or the screw terminal connector on the station backplane. Landline to Station signals are connected at Line 1 Audio or Line 3 Audio. Station to Landline signals are connected at Line 2 Audio or Line 4 Audio.

The WIB is equipped with two connectors to accept two plug-in ASTRO modem cards, one for each 4-wire modem data card.

are fed to two transistors which are connected in a push-pull configuration to drive the primary of an audio transformer. The modem data signal is induced into the secondary and output to the landline system (via either the 50-pin Telco connector or screw terminal connector) as balanced audio.

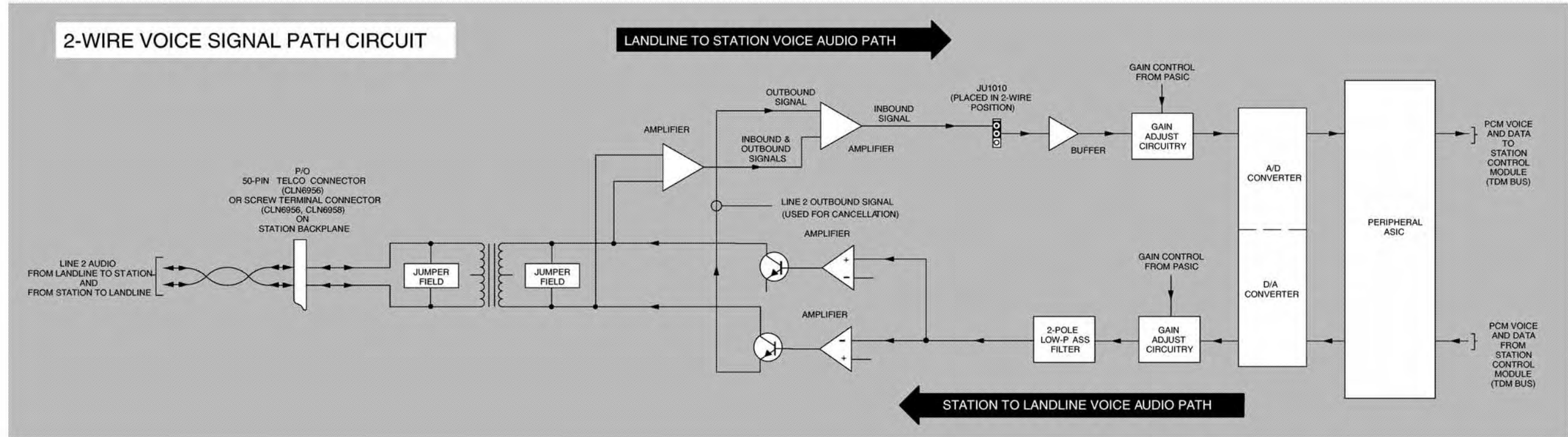

Figure 3 2-Wire Voice Audio Path Functional Block Diagram

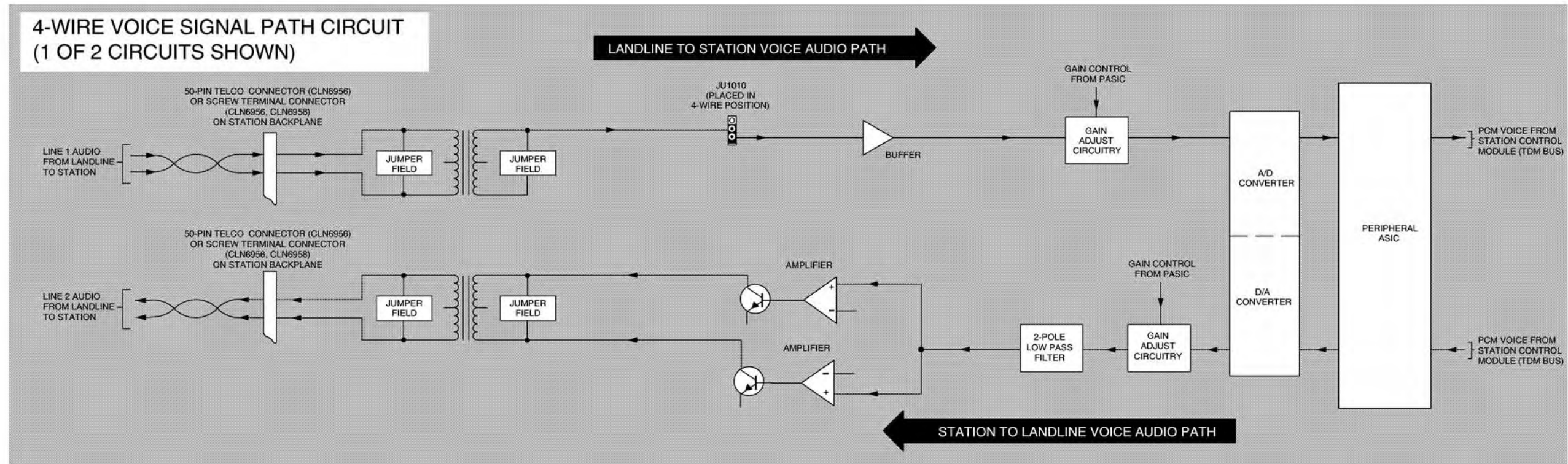

Figure 4 4-Wire Voice Audio Path Functional Block Diagram

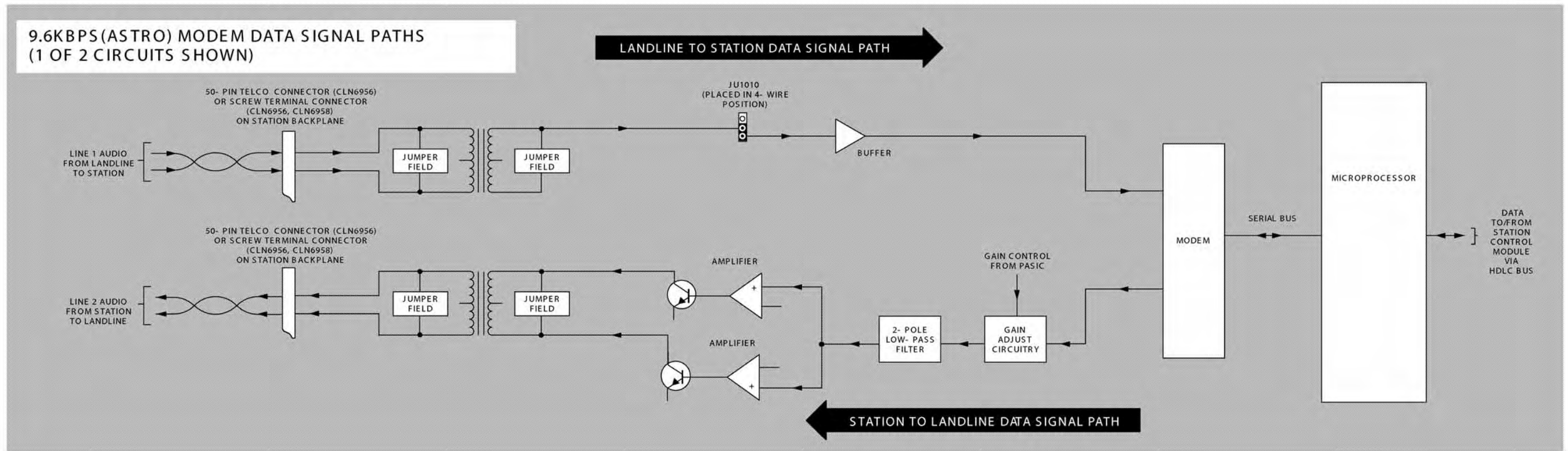

Figure 5 9.6kbps (ASTRO) Modem Data Signal Path Functional Block Diagram

### 1 DESCRIPTION

The TRN7480A Station Backplane Board provides the electrical interconnections for the plug-in modules of a *Quantar* station. The board also provides the connectors necessary to interface the station to phone lines, peripheral rf equipment, and other communications and maintenance equipment. This section provides a general description, identification of inputs/outputs, and a pin-out listing for all interface connectors, including information on signal names, functions, and levels.

#### General Description

The station backplane board (mounted across the rear of the *Quantar* station card cage) is constructed with connectors on both sides. The connectors on one side mate with the various station plug-in modules; the connectors on the other side allow interface connections between the station and the phone lines, peripheral rf equipment, and other communications and maintenance equipment.

A metal shield mounts over the rear of the backplane board to provide protection for the circuit board runners and connector solder pads, ESD protection, and EMI/RFI shielding, as shown in Figure 1. This shield also provides a mounting location for the antenna connector bracket and the station grounding lug.

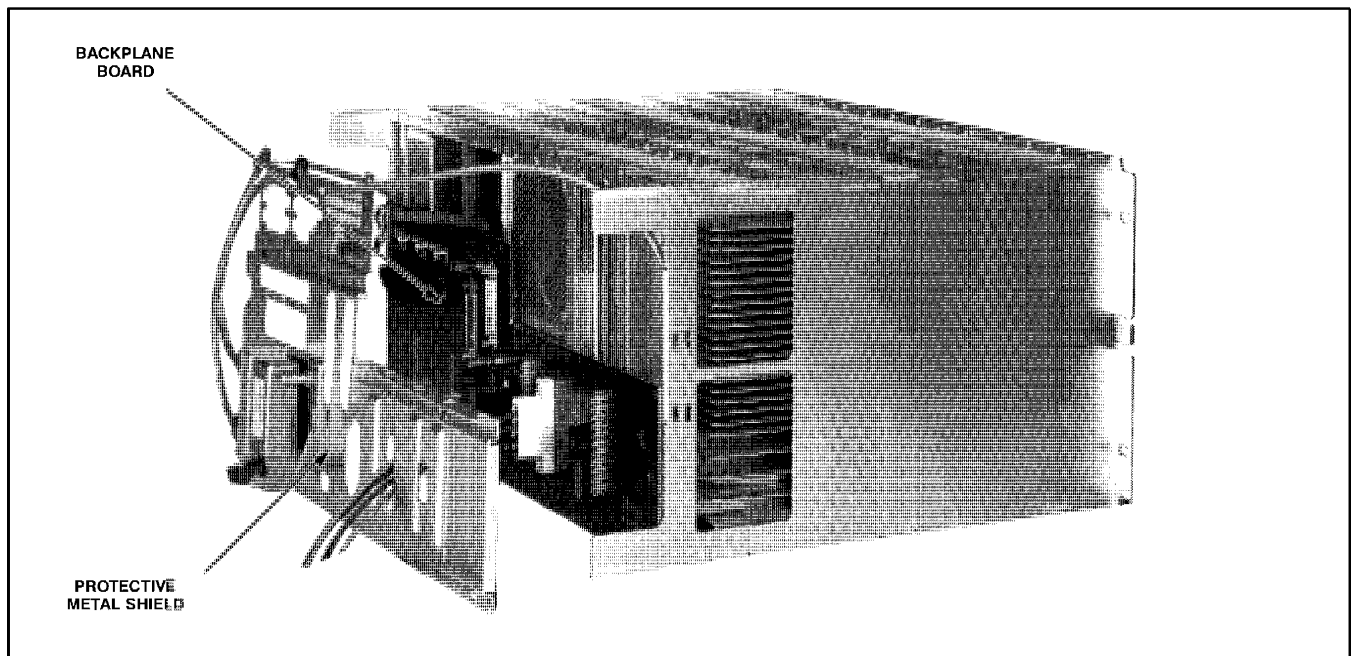

**Figure 1.** Backplane (Shown with Protective Metal Shield Removed)



## 2 LOCATION OF BACKPLANE CONNECTORS

Figure 1 shows the location of the connectors on each side of the station backplane board.

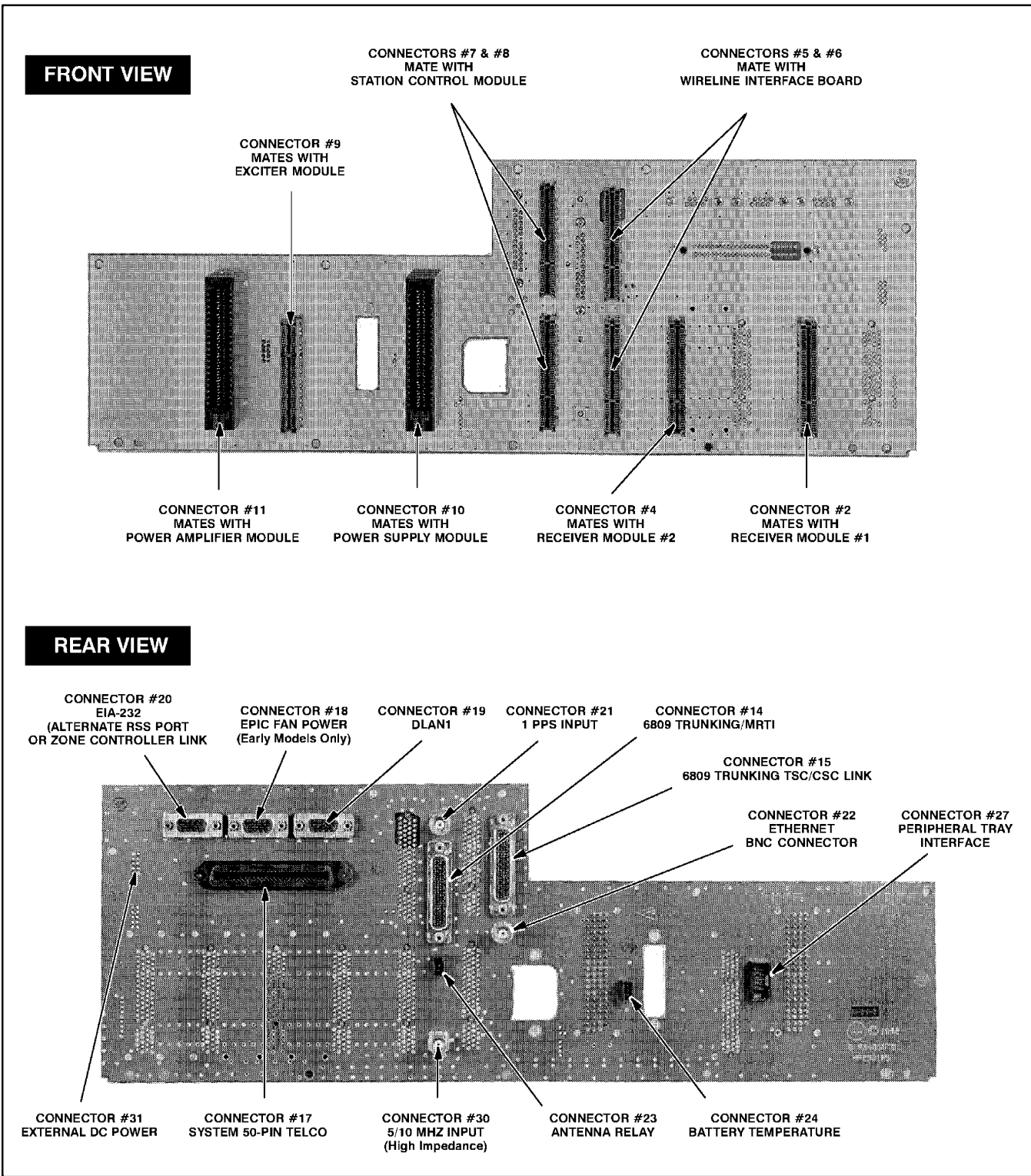

Figure 2. Quantar Station Backplane (TRN7480A) Connector Locations (Front and Rear Views)

### 3 BACKPLANE CONNECTORS INFORMATION

Each connector on the backplane has been assigned a connector number. In some cases, the connector number is stamped into the metal shield covering the rear of the backplane board. The connectors which accept the plug-in modules are not marked. Table 1 lists each connector and its assigned number.

Figure 3 provides pin-out information for all connectors located on the rear of the backplane board. As shown, each connector pin is defined by signal name, input or output (with reference to connector), to/from location, and a brief description of the signal function. Note that pin-out information for any connectors intended for future applications is not shown. Also, note that in the “To/From” column the source or destination of the signal is given as a connector number followed by a pin number. The first number (preceded by a “#”) represents the assigned connector number, followed by the specific connector pin number.

**Table 1.** Assigned Connector Number vs Function/Location Information

Connector #	Function/Location
1	Not used
2	Accepts plug-in Receiver Module #1
3	Not used
4	Accepts plug-in Receiver Module #2
5	Accepts bottom card-edge connector of plug-in Wireline Interface Board
6	Accepts top card-edge connector of plug-in Wireline Interface Board
7	Accepts bottom card-edge connector of plug-in Station Control Module
8	Accepts top card-edge connector of plug-in Station Control Module
9	Accepts plug-in Exciter Module
10	Accepts plug-in Power Supply Module
11	Accepts plug-in Power Amplifier Module
12	Not used
13	Not used
14	Provides interface for 6809 Trunking Controller and (future) MRTI Interface
15	Accepts TSC/CSC Link cable from 6809 Trunking Controller
16	Not used
17	50-pin Telco System Connector (accepts customer phone line connections, access to customer-defined inputs/outputs, Simulcast inputs, etc.; connector located on backplane at rear of station)
18	Provides dc power to external fan module for early model EPIC Station Control Modules (limited production)
19	DLAN1 DB-9 connector (used in <i>IntelliRepeater</i> applications to form network between multiple stations; connector located on backplane at rear of station; mates with DB-9-to-dual RJ11 <i>PhoneNET</i> adapter module; see note above)
20	EIA-232 asynchronous port (used for connection to <i>SMARTZONE</i> controller in wide-area <i>IntelliRepeater</i> trunking system or for alternate RSS port in a non- <i>IntelliRepeater</i> trunking system)
21	1 PPS input from GPS Receiver for <i>ASTRO</i> Simulcast systems
22	BNC connector which allows connection to an <i>IntelliRepeater</i> Ethernet network via a 10BASE-2 coaxial T-connector. Also may be used to locally connect PC running RSS to download software to FLASH memory in Station Control Module.
23	Antenna Relay 3-pin AMP-type connector (used to supply control signal to antenna relay module; connector located on backplane at rear of station)
24	Battery Temperature 3-pin AMP-type connector (used to accept variable resistance proportional to temperature of co-located storage batteries; connector located on backplane at rear of station)
25	Not used
26	Not used
27	RF Peripheral Tray 10-pin AMP-type connector (used to transfer signals to/from components housed in externally-mounted RF Peripheral Tray; connector located on backplane at rear of station)
28	Not used
29	Not used
30	BNC input connector (used to accept 5/10 MHz reference signal from external frequency standard for calibrating reference oscillator in Station Control Module; connector located on backplane at rear of station; electrically isolated from BNC connector on front panel of Station Control Module to allow for multi-drop configuration)
31	Provides external +5V and +14.2 V dc power (e.g., MRTI, Modem, etc.)

*PhoneNET* is a registered trademark of Farallon Computing, Inc.

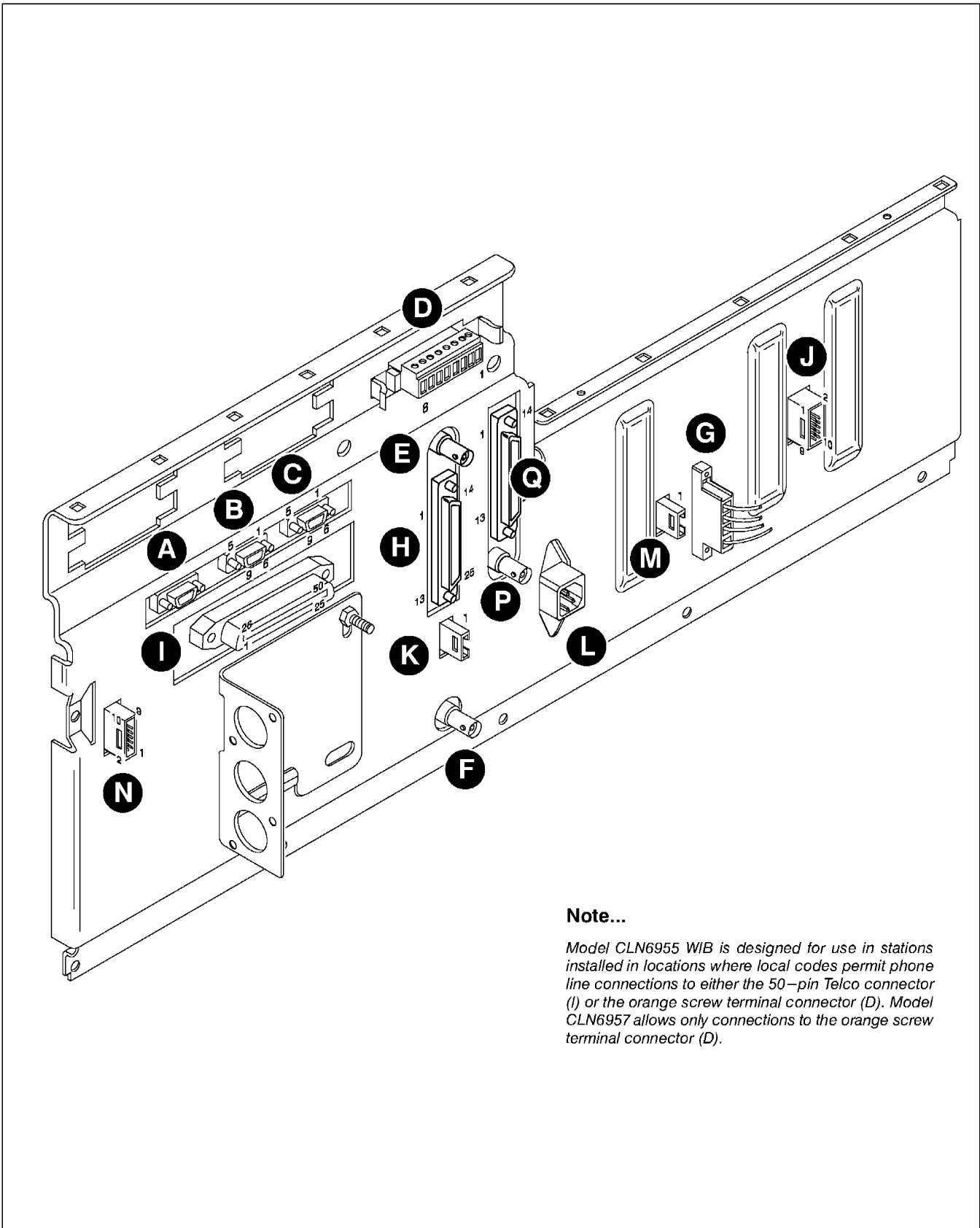

**Note...**

*Model CLN6955 WIB is designed for use in stations installed in locations where local codes permit phone line connections to either the 50-pin Telco connector (I) or the orange screw terminal connector (D). Model CLN6957 allows only connections to the orange screw terminal connector (D).*

**Figure 3.** TRN7480A Backplane Rear Connectors Pin-Out Information (Sheet 1 of 3)

**A**

**CONNECTOR #20** **EIA-232**  
(Alternate RSS Port)

Pin #	Signal	Input	Output	Function
1	DCD1	✓		Data Carrier Detect
2	RXD1	✓		Receive Data
3	TXD1		✓	Transmit Data
4	DTR	✓	✓	Data Terminal Ready
5	SIGNAL GND			Station Ground
6	DSR	✓		Data Set Ready
7	RTS1	✓	✓	Request to Send
8	CTS1	✓		Clear to Send
9	Ring Indicator			Not used

**B**

**CONNECTOR #18** **EPIC Fan Control**  
(Early Models Only)

Pin #	Signal	Input	Output	Function
1	FAN GND			Ground for external fan
2				
3				
4				
5				
6				
7				
8	FAN +		✓	+14.2 V dc for external fan
9				

**C**

**CONNECTOR #19** **DLAN1**

Pin #	Signal	Input	Output	Function
1	Shield Gnd			Station Ground
2	WFI+			Future use
3	WFI-			Future use
4	DLAN1+	✓	✓	Differential Data (+)
5	DLAN1-	✓	✓	Differential Data (-)
6	WFI+			Future use
7	WFI-			Future use
8	DLAN1+	✓	✓	Differential Data (+)
9	DLAN1-	✓	✓	Differential Data (-)

**D**

**PHONE LINE INPUTS**

1	LINE 1 +	5	LINE 3 +
2	LINE 1 -	6	LINE 3 -
3	LINE 2 +	7	LINE 4 +
4	LINE 2 -	8	LINE 4 -

**E**

**CONNECTOR #21**

**1 PPS**

1 PPS clock signal from GPS Receiver for ASTRO Simulcast application. TTL levels @ 50 ohms.

**F**

**CONNECTOR #30**

**5/10 MHZ INPUT**

Accepts external 5 or 10 MHz Frequency Standard for Calibrating Station Reference Oscillator (located in Station Control Module);  
5 MHz injection level = 1.0 ± .5 V RMS;  
High Impedance Input

**G**

**CONNECTOR #25**

**BATTERY CHARGER OUTPUT**

Two RED (top) and two BLACK (bottom) wires to battery revert connector mounted on station cage.

**H**

**CONNECTOR #14** **6809 TRUNKING/MRTI**

Pin #	Signal	Input	Output	Function
1	MRTI TX Audio			MRTI
2	MRTI PTT			MRTI
3	Open			MRTI
4	Monitor			MRTI
5	PL Strip			MRTI
6	Open			MRTI
7	MRTI RX Audio			MRTI
8	Patch INH			MRTI
9	Gnd			MRTI
10	AUX Indicate			Future use
11	TPTT	✓		Control signal to key transmitter (active low) (6809)
12	TSTAT		✓	Indicates transmitter status (active high) (6809)
13	Tx Data +	✓		Modulation input from 6809 Controller (6809)
14	Open			
15	Rx Carrier			MRTI
16	Gnd			Station Ground (6809)
17	Gnd			Station Ground (6809)
18	Gnd			Station Ground (6809)
19	Gnd			Station Ground (6809)
20	Gnd			Station Ground (6809)
21	Tx Data -	✓		Modulation input from 6809 Controller (6809)
22	Rx Wideband Aud		✓	Receive output to 6809 Controller (6809)
23	MUTE	✓		Mutes station signals (active low) (6809)
24	CCI	✓		Indicates Control Channel status (active low) (6809)
25	RSTAT		✓	Indicates receiver status (active high) (6809)

**I**

**CONNECTOR #17** **SYSTEM 50-PIN TELCO**

Pin #	Signal	Input	Output	Function
1	Line 1+	✓		Customer 4-wire Phone Line Input (Line 1+)
2	Line 2+	✓	✓	Customer 2-wire Phone Line Input/Output (Line 2+)
3	Line 3+	✓		Customer 4-wire Phone Line Input (Line 3+)
4	Line 4+	✓	✓	Customer 4-wire Phone Line Output (Line 4+)
5	Aux TX Audio	✓		Input from external device
6	Open			Open
7	GND			Station Ground
8	5 VDC Out		✓	+5V dc from Power Supply (1 Amp Max.)
9	Gen TX Data -			Modulation signal from Simulcast equipment (Note 1)
10	PL (+) In	✓		Future Use
11	Aux In 1 (Ext Fallsot)	✓		Customer-defined transistor buffered Input (Note 1)
12	Aux In 2 (TX Inhibit)	✓		Customer-defined transistor buffered Input (Note 1)
13	Aux In 3 (Ext TX Code Det)	✓		Customer-defined transistor buffered Input (Note 1)
14	Aux In 4 (RX WL Inhibit)	✓		Customer-defined transistor buffered Input (Note 1)
15	Aux In 5 (Duplex Enable)	✓		Customer-defined transistor buffered Input (Note 1)
16	Aux In 6 (In Cabinet Repeat)	✓		Customer-defined transistor buffered Input (Note 1)
17	Aux In 7 (Channel 4)	✓		Customer-defined transistor buffered Input (Note 1)
18	Aux Out 7 (RD Stat +)		✓	N.O. contact of Relay A (Note 1)
19	Aux Out 8		✓	N.O. contact of Relay B
20	Aux Out 9		✓	N.O. contact of Relay C
21	Aux Out 10		✓	N.O. contact of Relay D
22	Aux In 9 (Ext PTT +)	✓		Opto-isolated customer-defined input (Opto A+)
23	Aux In 10 (Channel 1 +)	✓		Opto-isolated customer-defined input (Opto B+)
24	Aux In 11 (Chanel 2 +)	✓		Opto-isolated customer-defined input (Opto C+)
25	Aux In 12 (Channel 3 +)	✓		Opto-isolated customer-defined input (Opto D+)
26	Line 1 -	✓		Customer 4-wire Phone Line Input (Line 1-)
27	Line 2 -	✓	✓	Customer 2-wire Phone Line Input/Output (Line 2-)
28	Line 3 -	✓		Customer 4-wire Phone Line Input (Line 3-)
29	Line 4 -	✓	✓	Customer 4-wire Phone Line Output (Line 4-)
30	Aux RX Audio		✓	Output to external device
31	Open			Open
32	GND			Station Ground
33	14.2 VDC Out		✓	+14.2 V dc from Power Supply (1 Amp Max.)
34	Gen TX Data +			Modulation signal from Simulcast equipment
35	PL (-) In	✓		Future Use
36	Aux Out 1 (Fallsot Ind)		✓	Customer-defined transistor buffered output (Note 1)
37	Aux Out 2 (RX Code Det)		✓	Customer-defined transistor buffered output (Note 1)
38	Aux Out 3		✓	Customer-defined transistor buffered output
39	Aux Out 4		✓	Customer-defined transistor buffered output
40	Aux Out 5		✓	Customer-defined transistor buffered output
41	Aux Out 6		✓	Customer-defined transistor buffered output
42	Aux In 8	✓		Customer-defined transistor buffered input
43	Aux Out 7 (RD Stat -)		✓	N.O. contact of Relay A (Note 1)
44	Aux Out 8		✓	N.O. contact of Relay B
45	Aux Out 9		✓	N.O. contact of Relay C
46	Aux Out 10		✓	N.O. contact of Relay D
47	Aux In 9 (Ext PTT -)	✓		Opto-isolated customer-defined input (Opto A-)
48	Aux In 10 (Channel 1 -)	✓		Opto-isolated customer-defined input (Opto B-)
49	Aux In 11 (Channel 2 -)	✓		Opto-isolated customer-defined input (Opto C-)
50	Aux In 12 (Channel 3 -)	✓		Opto-isolated customer-defined input (Opto D-)

**Notes:**

1. Many of the customer-defined inputs and outputs have been preassigned with signal names and functions usually required in typical Trunking and other systems. These default preassignments have been made for customer convenience only, and may be re-assigned as necessary. The preassigned signal names are shown in parentheses in the SIGNAL column. (Reassignment requires the use of the Wildcard Option.)

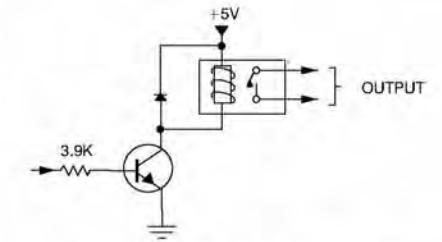

Typical Relay Closure Output Circuit

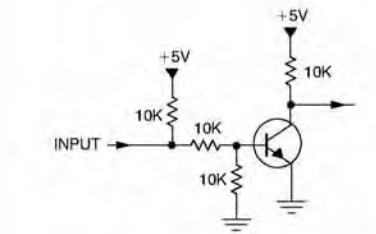

Typical Transistor-Coupled Input Circuit

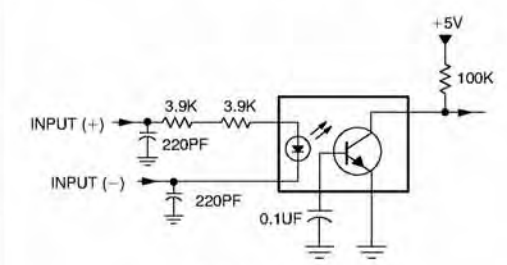

Typical Opto-Coupled Input Circuit

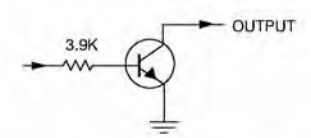

Typical Transistor-Coupled Output Circuit

Figure 3. TRN7480A Backplane Rear Connectors Pin-Out Information (Sheet 2 of 3)

**J**

CONNECTOR #27		PERIPHERAL TRAY INTERFACE		
Pin #	Signal	Input	Output	Function
1	14.2 V		✓	+14.2 V dc from Power Supply (1 Amp Max.)
2	GND			Station Ground
3	ANT RLY KEYED A+		✓	Switched +14.2 V to energize antenna relay (if located in Peripheral Tray)
4	EXT I/O 2			Future Use
5	EXT I/O 1		✓	Switched +14.2 V to energize Main/Standby relay
6	EXT Circ Temp	✓		DC voltage proportional to temperature from sensor mounted on Dual Circulator Module
7	EXT WM Ref			Ground reference for External Wattmeter
8	EXT WM Vr	✓		DC voltage proportional to External Wattmeter reflected power
9	EXT WM Vf	✓		DC voltage proportional to External Wattmeter forward power
10	GND			Station Ground

**N**

CONNECTOR #31		EXTERNAL DC POWER		
Pin #	Signal	Input	Output	Function
1	GND		✓	Station Ground
2	Spare			Not Used
3	Spare			Not Used
4	Spare			Not Used
5	Spare			Not Used
6	+14.2 V		✓	+14.2 V dc @ 1 Amp (if no connection to Connector #17—pin 33)
7	Spare			Spare
8	+5 V		✓	+5 V dc @ 1 Amp (if no connection to Connector #17—pin 8)
9	Spare			Not Used
10	GND		✓	Station Ground

**K**

CONNECTOR #23		ANTENNA RELAY		
Pin #	Signal	Input	Output	Function
1	GND			Station GND
2	ANT RLY KEYED A+		✓	Switched +14.2 V to energize antenna relay
3	GND			Station Gnd

**P**

**CONNECTOR #22**

**ETHERNET PORT**

Accepts 10BASE-2 coaxial cable (via T-connector) for connections to an *IntelliRepeater* Ethernet network or to download software via a locally connected PC running RSS.

**L**

**CONNECTOR #50**

**AC INPUT**

Connects to 110V/220V AC source via 3-wire line cord.

**Q**

CONNECTOR #15		MULTI-PURPOSE RS-232		
Pin #	Signal	Input	Output	Function
1	Shield Gnd			Station Ground
2	TxD3		✓	Transmit Data
3	RxD3	✓		Receive Data
4	RTS3		✓	Request to Send
5	CTS3	✓		Clear to Send
6	DSR3	✓		Data Set Ready
7	Signal Ground			Station Ground
8	DCD3	✓		Data Carrier Detect
9	OPEN			
10	OPEN			
11	OPEN			
12	OPEN			
13	Local Loopback 3		✓	Not Used
14	OPEN			
15	TCLK3		✓	Transmit Clock
16	OPEN			
17	RCLK	✓		Receive Clock
18	OPEN			
19	OPEN			
20	DTR3		✓	Data Terminal Ready
21	OPEN			
22	OPEN			
23	OPEN			
24	OPEN			
25	Remote Loopback 3		✓	Not Used

**M**

CONNECTOR #24		BATTERY TEMPERATURE		
Pin #	Signal	Input	Output	Function
1	GND			Station Ground
2	BATT TEMP	✓		Variable resistance proportional to battery temperature from sensor near storage batteries
3	GND			Station Ground

Figure 3. TRN7480A Backplane Rear Connectors Pin-Out Information (Sheet 3 of 3)

**INCLUDES MODELS:****CPN1049F (265W w/o Battery Charger; AC Input)  
CPN1050G (265W with Battery Charger; AC Input)**

## **1** DESCRIPTION

The Models CPN1049F / CPN1050G Power Supply Modules are described in this section. A general description, performance specifications, identification of controls, indicators, and inputs/outputs, a functional block diagram, and functional theory of operation are provided. The information provided is sufficient to give service personnel a functional understanding of the module, allowing maintenance and troubleshooting to the module level. (Refer also to the Maintenance and Troubleshooting section of this manual for detailed troubleshooting procedures for all modules in the station.)

### **General Description**

The Models CPN1049 / CPN1050 Power Supply Modules each accept an ac input (90–264 V ac, 47–63 Hz) and generate +14.2V dc and +5.1V dc operating voltages to power the station modules. Each power supply module is comprised of three circuit boards which provide several switching-type power supply circuits, power factor correction circuitry, battery charger/revert circuitry (CPN1050 only), and diagnostics and monitoring circuitry, all contained within a slide-in module housing.

The power supply module provides the following features:

- **Auto-ranging for input voltage and frequency** — circuitry automatically adjusts for input ranges of 90–264 V ac and 47–63 Hz; no jumpers, switches, or other settings are required
- **Input transient and EMI protection** — MOV, gas discharge, and filter devices protect the power supply circuitry from ac line voltage transients and electro-magnetic interference
- **Internal voltage and current limiting** — circuitry continually monitors critical voltages and currents and shuts supply down if preset thresholds are exceeded
- **Temperature protection** — module contains built-in cooling fan; supply shuts down if temperature exceeds preset threshold
- **Diagnostic monitoring** — critical internal parameters are continually monitored and reported to the Station Control Module, which can automatically provide correction for certain operating conditions

— continued on next page —

**General Description  
(continued)**

- **Fan Failure Protection** — Power Supply enters shutdown mode in event of cooling fan failure
- **Battery Reverse Polarity Protection** — Charger circuitry is protected against connecting the external battery in reverse polarity (CPN1050 only)
- **Auto Switchover to/from Battery** — If AC input fails, station is automatically switched over to battery operation; when AC input is restored, station is automatically switched back to power supply operation (CPN1050 only)
- **Auto Recovery from Shutdown** — Power Supply automatically recovers from shutdown mode if the cause of the shutdown no longer exists
- **Software-Controlled Battery Charging Voltage** — The battery charging voltage and current is controlled based on the ambient temperature (CPN1050 only)
- **Limited In-Rush Current** — Circuitry limits in-rush current to less than 30 A in all conditions

The Models CPN1049 and CPN1050 differ only in the inclusion of battery charger/revert board (CPN1050 only). Unless otherwise noted, the information provided in this section applies to both models.

**Power Supply Module  
Simplified Block Diagram**

The illustration below provides a simplified block diagram of a Power Supply Module (with battery charger) showing how the three circuit boards interconnect. A detailed block diagram and functional theory of operation for each board is provided later in this section (beginning on page 6).

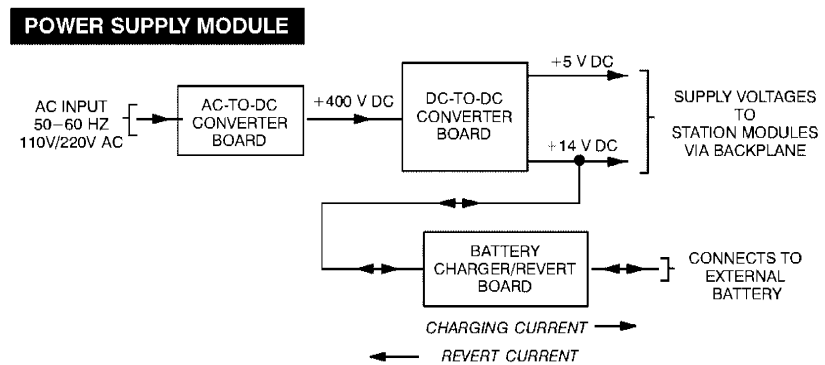

---

## Overview of Circuitry

The power supply module is comprised of three circuit boards, connected together via cables. These boards contain circuitry as follows:

### ***AC-to-DC Converter Board (CPN6065D)***

- **Input Conditioning Circuitry** — consists of ac line transient protection, EMI filtering, front panel on/off switch, startup-delayed relay, and a full-wave rectifier.
- **Startup Delay Circuitry** — provides a delay of approximately 1.5 seconds from time on/off switch is turned on until the power supply becomes functional (allows pre-charge of high-capacity filter capacitors to limit in-rush current on power up).
- **Boost/Power Factor Correction Circuitry** — consists of switching-type power supply that generates +400V dc for use by DC-to-DC Converter Board, as well as providing power factor correction.
- **Battery Revert Trigger Circuitry** — Monitors +400 V dc and generates a signal to the Battery Charger/Revert Board to activate battery revert if the +400 V dc fails or drops below approximately +350 V dc.
- **VCC Supply Circuitry** — consists of switching-type power supply that generates the VCC supply voltage (approximately +13V dc) for use by circuitry on AC-to-DC Converter Board and DC-to-DC Converter Board.

### ***DC-to-DC Converter Board (CPN6079E)***

- **+14 V Supply Circuitry** — consists of switching-type power supply that generates the +14 V dc supply voltage and provides primary/secondary isolation.
- **+5 V Supply Circuitry** — consists of switching-type power supply that generates the +5 V dc supply voltage (from +14 V dc supply voltage).
- **Battery Charger Control Circuitry** — Provides buffering for signals related to battery charging/revert operation.
- **Reference Voltage Circuitry** — Generates +10V\_SEC and +2.5V\_SEC supply voltages for use by local circuitry.
- **Diagnostics Circuitry** — converts analog status signals to digital format for transfer to Station Control Module.
- **Address Decode Circuitry** — performs address decoding to provide chip select signal for the A/D converter.
- **Startup/Shutdown Control Circuitry** — Provides delay intervals for startup and shutdown of entire power supply module.

— continued on next page —



---

## Overview of Circuitry (Continued)

### **Battery Charger/Revert Board (CPN6074C)**

- **Charger Supply Circuitry** — consists of switching-type power supply that generates charging current for the external storage battery.
- **Pulse Width Modulator Circuitry** — consists of pulse-width modulator, boost switch timer, and driver circuitry to provide variable-width pulses for the FET switches in the Charger Supply Circuitry.
- **Battery Revert Circuitry** — consists of signal monitoring circuitry which turns on the Battery Revert FET Switches for certain input signal conditions (such as AC Fail).
- **Current Mode Controller Circuitry** — consists of current and voltage feedback signal monitoring circuitry which controls the Pulse Width Modulator Circuitry to maintain the desired charger output current and voltage.
- **SPI Bus Interface Circuitry** — consists of a D/A converter which accepts charger control digital signals from the Station Control Module and converts these signals to analog dc voltages to control various operating characteristics of the battery charger circuitry.
- **Shutdown Circuitry** — consists of signal monitoring circuitry which shuts down the battery charger for certain input signal conditions (such as loss of BATT\_WATCHDOG signal from the Station Control Module).
- **Local Supplies Circuitry** — Accepts +14V\_RAW (from DC-to-DC Converter Board) and generates VCC (+10V) and +5V supply voltages for use by local circuitry.

## 2 PERFORMANCE SPECIFICATIONS

Table 1 shows the electrical performance specifications for the Models CPN1049 and CPN1050 Power Supply Modules.

### Performance Specifications

**Table 1.** CPN1049 / CPN1050 Power Supply Modules Performance Specifications

Parameter	Specification
Weight	6.5 kg (14.3 lbs)
Operating Temperature Range	-30 to +60° C (no derating)
Input Voltage Range	90 to 264 V ac
Input Frequency Range	47 to 63 Hz
Maximum Input Current	8.5 A
Steady State Output Voltages	+14.2 V dc ±5% +5.0 V dc ±5%
Output Current Ratings	+14.2 12.5 A +5.1 9 A
Total Output Power Rating	265W* <i>* including 100W for battery charger</i>
Output Ripple	All outputs 150 mV p-p (measured with 20 MHz BW oscilloscope at 25°C).

### 3 CONTROLS, INDICATORS, AND INPUTS/OUTPUTS

Figure 1 shows the power supply module controls, indicators, and all input and output external connections.

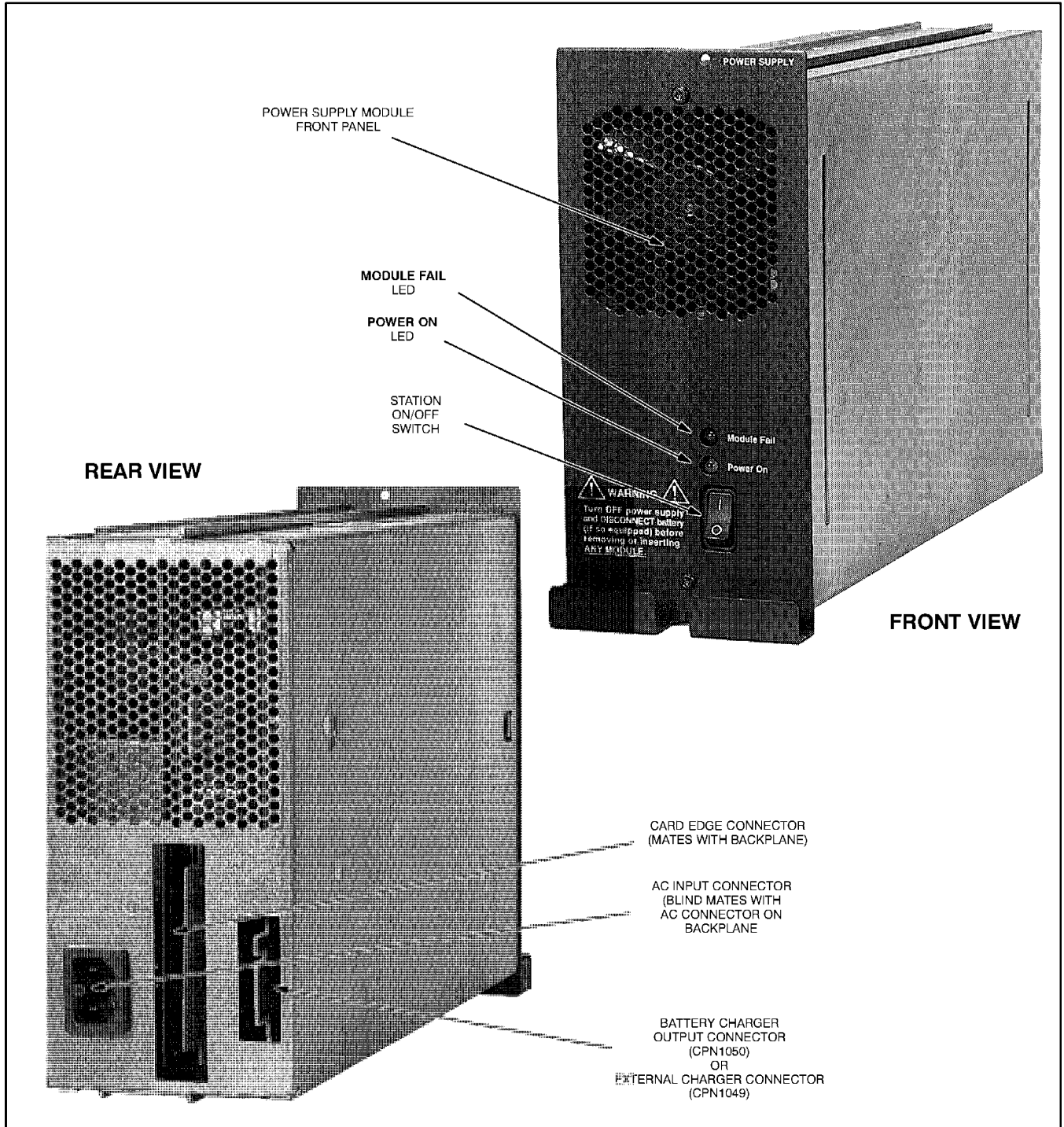

Figure 1. CPN1049 / CPN1050 Power Supply Module Controls, Indicators, and Inputs/Outputs

## 4 FUNCTIONAL THEORY OF OPERATION (AC-to-DC Converter Board)

The following theory of operation describes the operation of the CPN6065D AC-to-DC Converter Board circuitry at a functional level. The information is presented to give the service technician a basic understanding of the functions performed by the module in order to facilitate maintenance and troubleshooting to the module level. Refer to Figure 2 for a block diagram of the AC-to-DC Converter Board.

### Input Conditioning Circuitry

#### *Introduction*

The AC-to-DC Converter Board accepts ac power from an external source, typically a 110V or 220/240V ac wall receptacle. AC power is connected to the board via a 3-wire line cord plugged into an ac receptacle mounted on the station backplane, into which the entire power supply module slides (blind mate connection).

#### *Transient and EMI Protection*

The ac line input is fed to the AC-to-DC Converter Board circuitry via transient protection and EMI filter circuits. The transient protection devices provide protection against voltage spikes by providing an effective short to ground under high voltage transient conditions. The EMI filter prevents electrical noise generated by the power supply module from interfering with other equipment connected to the same ac line circuit.

#### *Front Panel On–Off Switch / Relay Circuitry*

A rocker-type switch located on the power supply module front panel allows the power supply (and station) to be turned on and off. Note that the switch allows the filter circuitry (p/o Boost/Power Factor Correction Circuitry) to slowly charge (for approximately 1.5 seconds after switch is turned on) through two diodes and resistors. After the 1.5 second delay, the relay turns on and provides an ac input to the bridge rectifier. This 1.5 second pre-charge delay period limits in-rush current through the filter capacitors upon power up.

#### *Rectifier Circuitry*

The ac line voltage (via the relay) is rectified by a full-wave bridge rectifier and fed to the Boost/Power Factor Correction Circuitry.

### Startup Delay Circuitry

This circuitry monitors the ac input (from the on/off switch) and provides a 1.5 second delay when switch is turn on before energizing the relay to turn on the power supply.

If the AC input is below approximately 85 V rms, the relay will not be turned on and the power supply outputs will be disabled. The red **Module Fail** LED on the front panel will light.

---

## Boost/Power Factor Correction Circuitry

### Overview

The Boost/Power Factor Correction Circuitry is comprised of a switching-type power supply which generates a +400 V dc voltage. This voltage is fed to the DC-to-DC Converter Board to be used as the source for the +14V and +5V Supply Circuits.

### Switching Power Supply Operation

The switching power supply consists of a pulse width modulator (PWM) running at 67 kHz. The PWM output pulses are fed through driver transistors to control three power FETs which rapidly switch the Toroid Power Coil to ground. The result is a high induced current which charges the filter capacitors to approximately 400 V dc.

Note that the PWM output pulses are also controlled by voltage and current feedback signals. These feedback signals allow the average ac line current over switching cycles to be sinusoidal and in-phase with the ac input voltage (i.e., power factor corrected).

---

## Battery Revert Trigger Circuitry

A comparator monitors the +400 V dc from the output of the Boost/Power Factor Correction Circuitry and a +5V reference signal. If the +400 V dc voltage should drop below approximately +350 V dc (considered an ac input failure), a BOOST\_LOW signal is sent to the Battery Charger/Revert Board (via the DC-to-DC Converter Board) to activate battery revert mode.

---

## VCC Supply Circuitry

This circuitry consists of a switching-type power supply which generates a +13 V dc supply voltage used as VCC by the local circuitry and the primary side of the DC-to-DC Converter Board.

The circuitry consists of a pulse width modulator (PWM) running at 67 kHz (from DC-to-DC Converter Board). The PWM output repetitively gates the +400 V dc (from the Boost/Power Factor Correction Circuitry) to the primary of the housekeeping transformer. The result is an induced voltage in the secondary winding which feeds a half-wave rectifier circuit. The output is a +13 V dc VCC supply voltage.

---

## LED Status Indicators

Two LEDs located on the power supply module front panel indicate module status as follows:

- **AC On**— lights GREEN when On/Off switch is On and the AC input voltage is within operating range; LED turns off when module is turned off, ac power is removed, or AC input voltage is below approximately 85 V rms.
- **Module Fail**— lights RED when initially turning on or off the Power Supply (this is normal and does not indicate a failure), when the DC-to-DC Converter Board is not functioning properly, or when the Boost Circuitry is not functioning properly; LED turns off when module is functioning properly

**Note** *When in Battery Revert Mode (CPN1050 only), neither LED is lit. The cooling fan will continue to run.*

## 5 FUNCTIONAL THEORY OF OPERATION (DC-to-DC Converter Board)

The following theory of operation describes the operation of the CPN6079E DC-to-DC Converter Board circuitry at a functional level. The information is presented to give the service technician a basic understanding of the functions performed by the module in order to facilitate maintenance and troubleshooting to the module level. Refer to Figure 3 for a block diagram of the DC-to-DC Converter Board.

### +14V Main Supply Circuitry

#### **Overview**

The +14V Main Supply Circuitry is comprised of two mirrored switching-type power supplies which generate the +14 V supply voltage. This voltage is used as the source for the +5V supply circuit, as well as the +14V supply voltage for the station modules (via the backplane) and

#### **Switching Power Supply Operation**

The +14V Main Supply Circuitry consists of two identical switching-type power supplies operating in parallel. Both supplies operate identically, as follows. A 133 kHz clock signal from the Sync Generator Circuitry is fed through a buffer to a Pulse Width Modulator (PWM). The PWM output pulses control a pair of power FETS (via a driver) to gate the +400 V dc (from the AC-to-DC Converter Board) to the primary of a power transformer. The induced voltage in the transformer secondary is half-wave rectified to charge the output filter circuitry, resulting in an output voltage of +14 V dc.

Since each supply receives a 133 kHz clock signal that is 180° out of phase with the other, each switching power supply alternately charges the output filter circuitry, resulting in an effective charging rate of 266 kHz.

#### **Protection Circuitry**

**Peak/Average Current Limiting Circuitry** — The peak current limiting circuitry accepts an output current feedback signal and a scaled +14V\_RAW reference signal to control the PWMs. This effectively maintains a constant output voltage for varying output current demands.

The average current limiting circuitry monitors the +14 V dc output and generates a shutdown signal (MAIN\_SD\_PRI) if the average output current reaches a predetermined limit.

**Overvoltage Protection Circuitry** — This circuitry monitors the +14V output voltage and generates a shutdown signal (MAIN\_SD\_SEC) to shut down the entire power supply module if the +14 V output voltage exceeds a preset threshold.

---

## +5 V Supply Circuitry

### **Overview**

The +5 V Supply Circuitry is comprised of a switching-type power supply which generates a +5 V dc supply voltage. This voltage is used as the +5 V supply voltage for the station modules (via the backplane).

### **Switching Power Supply Operation**

The +5 V switching power supply consists of a pulse width modulator (PWM) running at 133 kHz. The PWM output pulses are fed through a driver to control a power FET which repetitively gates the +14V\_RAW (from the +14V Main Supply Circuitry) to a power coil. The result is a high induced voltage which charges the filter capacitors to approximately +5 V dc. A current sense comparator provides a feedback signal to the PWM to maintain a constant output voltage.

### **Protection Circuitry**

An overvoltage detect circuit monitors the output voltage and, if preset thresholds are exceeded, turns on a FET crowbar circuit which immediately discharges the output to protect other modules in the station.

An overcurrent detect circuit monitors the current draw from the +5V Supply Circuitry and, if a preset threshold is exceeded, generates a MAIN\_SD\_SEC signal which shuts down the entire power supply module.

---

## Battery Charger Control Circuitry

The AC\_FAIL signal (from the AC-to-DC Converter Board) is buffered and fed to 1) the diagnostics circuitry as AC\_GOOD\_DIAG, and 2) the Battery Charger/Revert Board as BATTERY\_REVERT. This signal activates battery revert mode.

---

## Reference Voltage Circuitry

This circuitry accepts +14V\_RAW (from the +14V Main Supply Circuitry) and generates +10V\_SEC and +2.5V\_SEC supply voltages for use by local circuitry.



---

## Diagnostics Circuitry

### **Overview**

The diagnostics circuitry consists of an 11-channel A/D converter which converts analog status signals from critical points in the power supply module to digital format for transfer to the Station Control Module via the SPI bus. Most of the status signals are generated by detect circuits to indicate the status of dc supply voltages and references.

### **Temperature Monitor and Control Circuitry**

A thermistor mounted on the power supply module heatsink provides a varying resistance input to the Heatsink Temp Detect Circuitry. If the heatsink temperature exceeds a preset limit, the circuitry generates a MAIN\_SD\_SEC shutdown signal which shuts down the entire power supply module. A HEATSINK\_DIAG signal is also sent to the Station Control Module via the A/D converter and SPI bus.

### **Fan Monitor and Control Circuitry**

The cooling fan in the power supply module is powered from the +14V Supply Circuitry and runs continuously. If the fan fails, the Fan Fault Detect circuit generates a fail signal (FAN\_FAIL\_DIAG) which is fed to the A/D converter. The fail signal also triggers a 50 second delay circuit which (after 50 seconds) generates a MAIN\_SD\_SEC signal which shuts down the entire power supply.

---

## Address Decode Circuitry

The address decode circuitry allows the Station Control Module to use the address bus to select either the D/A converter (Battery Charger/Revert Board) or the A/D converter (Diagnostics Circuitry) for communications via the SPI bus. Typical communications include reading status signals from the Diagnostics Circuitry and providing charger output control signals to the Battery Charger/Revert Board.

---

## **Startup/Shutdown Control Circuitry**

### ***Shutdown Delay Circuitry***

Upon receiving a shutdown signal (MAIN\_SD\_PRI) from the +14V Main Supply Circuitry, this circuit passes the signal through the Soft Start Circuitry for a 1 second interval to allow the entire power supply module to shutdown. The module then restarts (if the on/off switch is in **On** position). If the MAIN\_SD\_PRI signal is still active, the shutdown process will repeat.

### ***Startup/Shutdown Delay Circuitry***

When the power supply module is first turned on, the RELAY\_ON signal is low and the output of the Startup/Shutdown Delay Circuitry keeps the supply in shutdown mode. After about 1.5 seconds RELAY\_ON goes high, and the Startup/Shutdown Delay Circuitry provides a 1 second delay before releasing the shutdown signal and allowing the power supply to operate.

When the power supply module is turned off, the RELAY\_ON signal goes low and the Startup/Shutdown Delay Circuitry keeps the supply in operating mode for 1 second to allow Battery Revert Mode to activate.

### ***Soft Start Circuitry***

Each time the Soft Start Circuitry receives a startup signal (i.e., MAIN\_SD\_PRI is inactive and the output of the Startup/Shutdown Delay Circuitry is high), the Soft Start Circuitry provides a gradually increasing output signal to “soft start” the Pulse Width Modulators (p/o +14V Main Supply Circuitry). This action minimizes the surge current when charging the output filter capacitors.

**6****FUNCTIONAL THEORY OF OPERATION  
(Battery Charger/Revert Board)**

The following theory of operation describes the operation of the CPN6074C Battery Charger/Revert Board circuitry at a functional level. The information is presented to give the service technician a basic understanding of the functions performed by the module in order to facilitate maintenance and troubleshooting to the module level. Refer to Figure 4 for a block diagram of the Battery Charger/Revert Board.

**Note** Model CPN1049F Power Supply Modules (without battery charging capabilities) are equipped with a CPN6078B External Charger Connect Board in place of the CPN6074C Battery Charger/Revert Board. The External Charger Connect Board provides a direct electrical path from the +14V Main Supply Circuitry (p/o the DC-to-DC Converter Board) to the card edge connector used to connect to an external charger and battery. The external charger is responsible for 1) charging the external battery and 2) detecting an AC power fail condition and initiating battery revert mode.

**Charger Supply Circuitry****Overview**

The Charger Supply Circuitry is comprised of a switching-type power supply which generates the charging current necessary to charge an external storage battery.

**Switching Power Supply Operation**

The charger switching power supply accepts +14V (from the DC-to-DC Converter Board) which is fed through a filter and a Buck FET Switch to a Power Coil. This coil is controlled by the Buck FET Switch and a Boost FET Switch to produce an induced output voltage of approximately +12 to +16 V dc. This charging voltage is filtered and fed through a pair of Reverse Battery FET Switches to the output terminals (card edge connector that extends from the rear of the Power Supply Module). Connections to an external storage battery are made to this card edge connector.

Protection against connecting the battery in reverse polarity is provided by the Charger Output Control Circuitry and the Reverse Battery FET Switches.

A thermistor mounted near the battery and connected to the station via a backplane connector provides an input to a comparator. The comparator output (BATT\_T\_DIAG) provides a dc voltage proportional to the battery temperature. This signal is sent to the Station Control Module via the Diagnostics Circuitry on the DC-to-DC Converter Board.

---

## Pulse Width Modulator Circuitry

A 133 kHz clock signal (from the DC-to-DC Converter Board) is fed through a buffer/driver to a Pulse Width Modulator (PWM). The 133 kHz PWM output pulses are fed 1) directly to the Buck FET Switch via a driver, and 2) to the Boost FET Switch via a Boost Switch Timer and Driver. The two signals control the respective FET switches to control the Power Coil in the Charger Supply Circuitry so that it produces an approximately +12 to +16 V dc output to be filtered and charge the external battery.

---

## Battery Revert Circuitry

### Overview

The Battery Revert Circuitry accepts various inputs and determines when to activate battery revert mode by turning on the Battery Revert FET Switches. Battery Revert Mode will be activated or deactivated in the following conditions:

- If the AC\_FAIL signal (from the DC-to-DC Converter Board) goes low (indicating that AC power has failed), the Battery Revert FET Switches will be turned on (via the FET Driver).
- If the battery voltage is too low, the Undervoltage Detect circuit detects the condition and disables the battery revert circuitry.
- If the battery voltage is too high, the Overvoltage Detect circuit detects the condition and disables the battery charger and the battery revert circuitry.
- If a fault condition exists (e.g., +5V Overcurrent), the shutdown detect circuitry detects the condition and disables the battery charger and the battery revert circuitry.

---

## Current Mode Controller Circuitry

### Overview

The Current Mode Controller Circuitry performs two major functions:

- The PWR\_CUT signal (from the DC-to-DC Converter Board) is fed through a Voltage Scaling Circuit and reduces the battery charger output current during periods of heavy current draw by the station.
- The Voltage Scaling Circuitry accepts V\_BC\_RAW (voltage feedback signal from battery) and BATT\_VOLT\_RANGE and BATT\_VOLT\_SELECT signals (from the Station Control Module via the D/A Converter) which combine to set the charger output voltage (in a range of +12 V dc to +16 V dc).

---

## SPI Bus Interface Circuitry

This circuitry consists of a D/A Converter that accepts digital signals from the Station Control Module and converts them to analog signals which control the operation of the Battery Charger/Revert Board. These signals:

- Control the charger voltage to the battery (BATT\_VOLT\_RANGE and BATT\_VOLT\_SELECT)
- Disable the Undervoltage Detect Circuitry (UVLO\_DISABLE) to allow the station to continue operation even though the battery voltage is below the desired level
- Provide a watchdog signal to refresh the Watchdog Timer Circuitry (BATT\_WATCHDOG)

---

## Shutdown Circuitry

This circuitry accepts four input signals and generates a shutdown signal to shut down the battery charger for certain input signal conditions. A shutdown signal will be generated for any of the following conditions:

- The BATT\_WATCHDOG signal (from the Station Control Module) is not present (indicating that the Station Control Module has failed, or the station's *Battery Type* field has been programmed (via RSS) for "NONE")
- The OVLO\_LCKOUT signal is high (indicating that the battery voltage is too high)
- The MAIN\_SD\_SEC signal is low (indicating that one of the various monitoring points indicates a fault, such as overcurrent condition for +14V or +5 V supplies, overcurrent condition for entire Power Supply Module, etc.)
- The AC\_FAIL signal is high (indicating that the AC power to the Power Supply Module has been interrupted)

---

## Local Supplies Circuitry

This circuitry contains two voltage regulators which accept +14V\_RAW (from the +14V Main Supply Circuitry) and generate VCC (+10 V dc) and +5 V supply voltages for use by local circuitry.

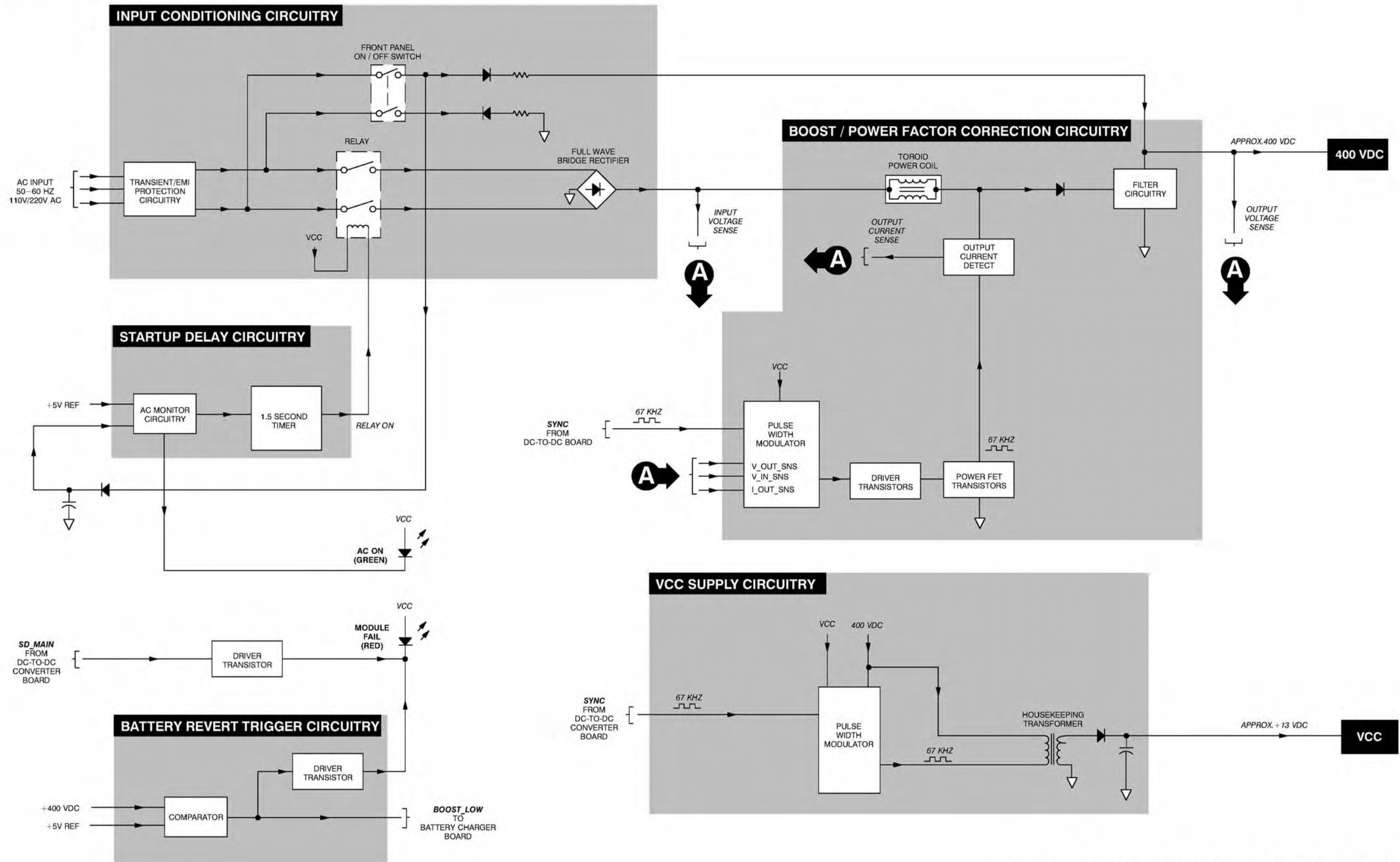

Figure 2. CPN6065D AC-to-DC Converter Board Functional Block Diagram

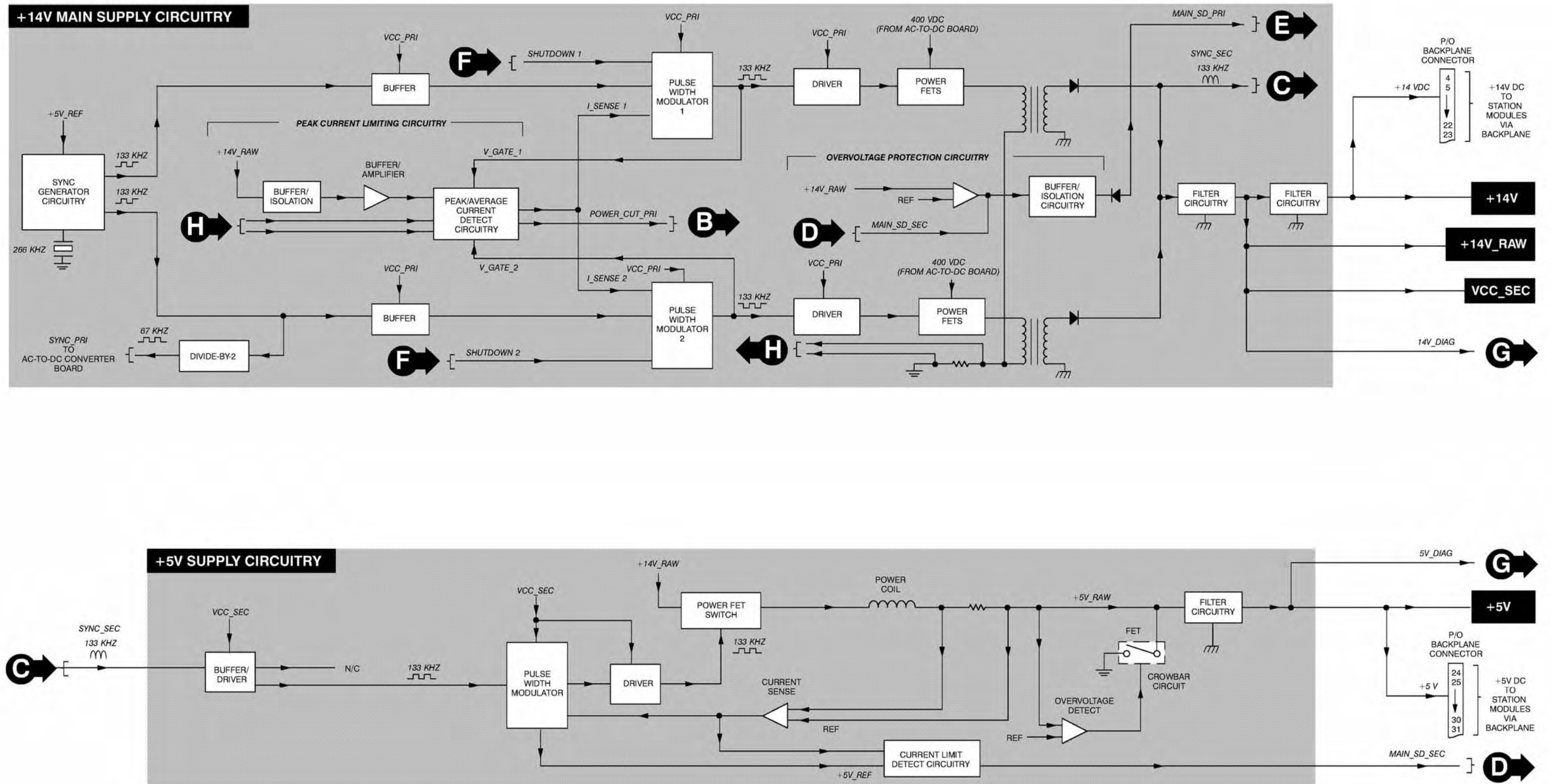

Figure 3. CPN6079E DC-to-DC Converter Board Functional Block Diagram (1 of 2)

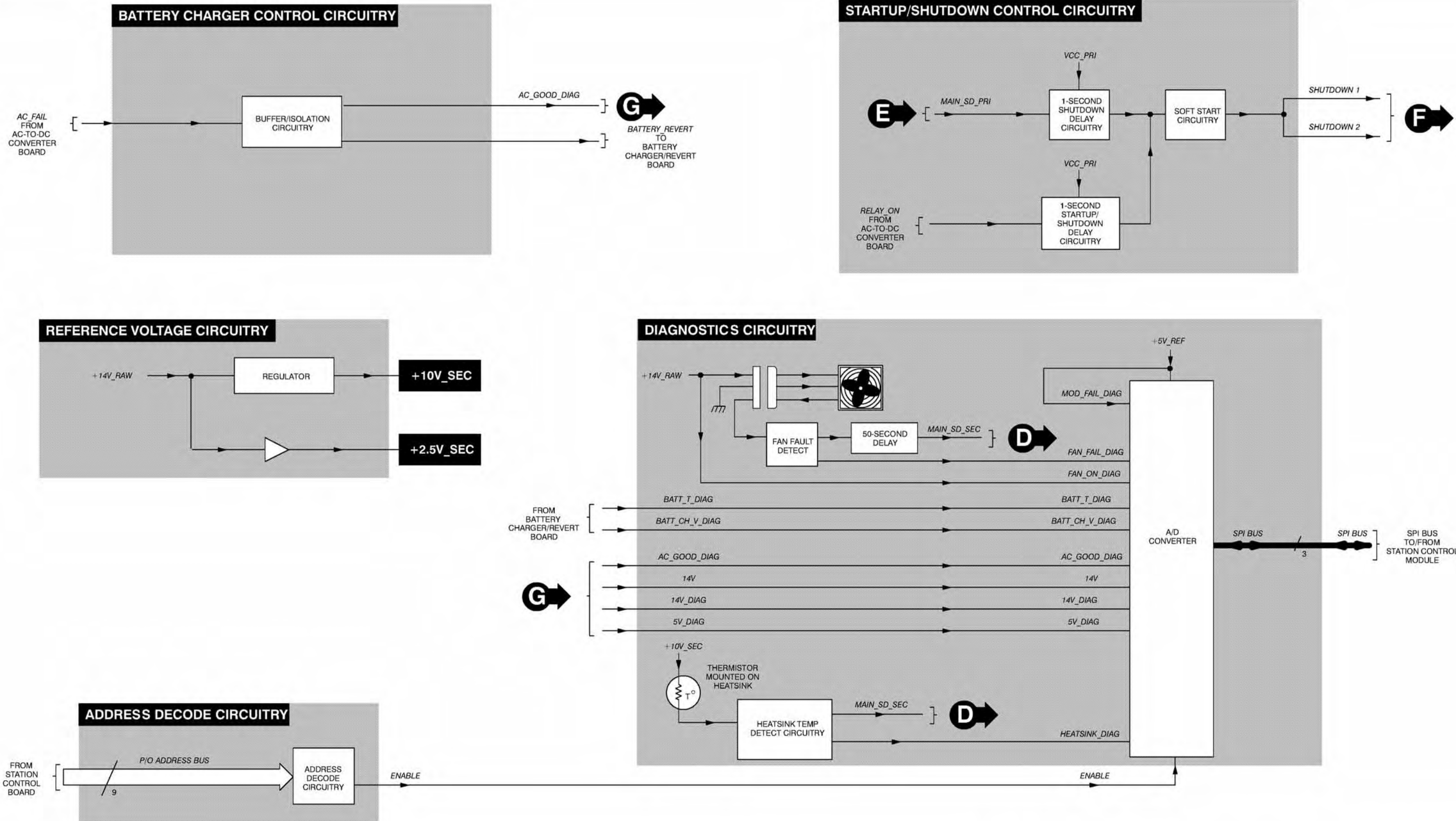

Figure 3. CPN6079E DC-to-DC Converter Board Functional Block Diagram (2 of 2)



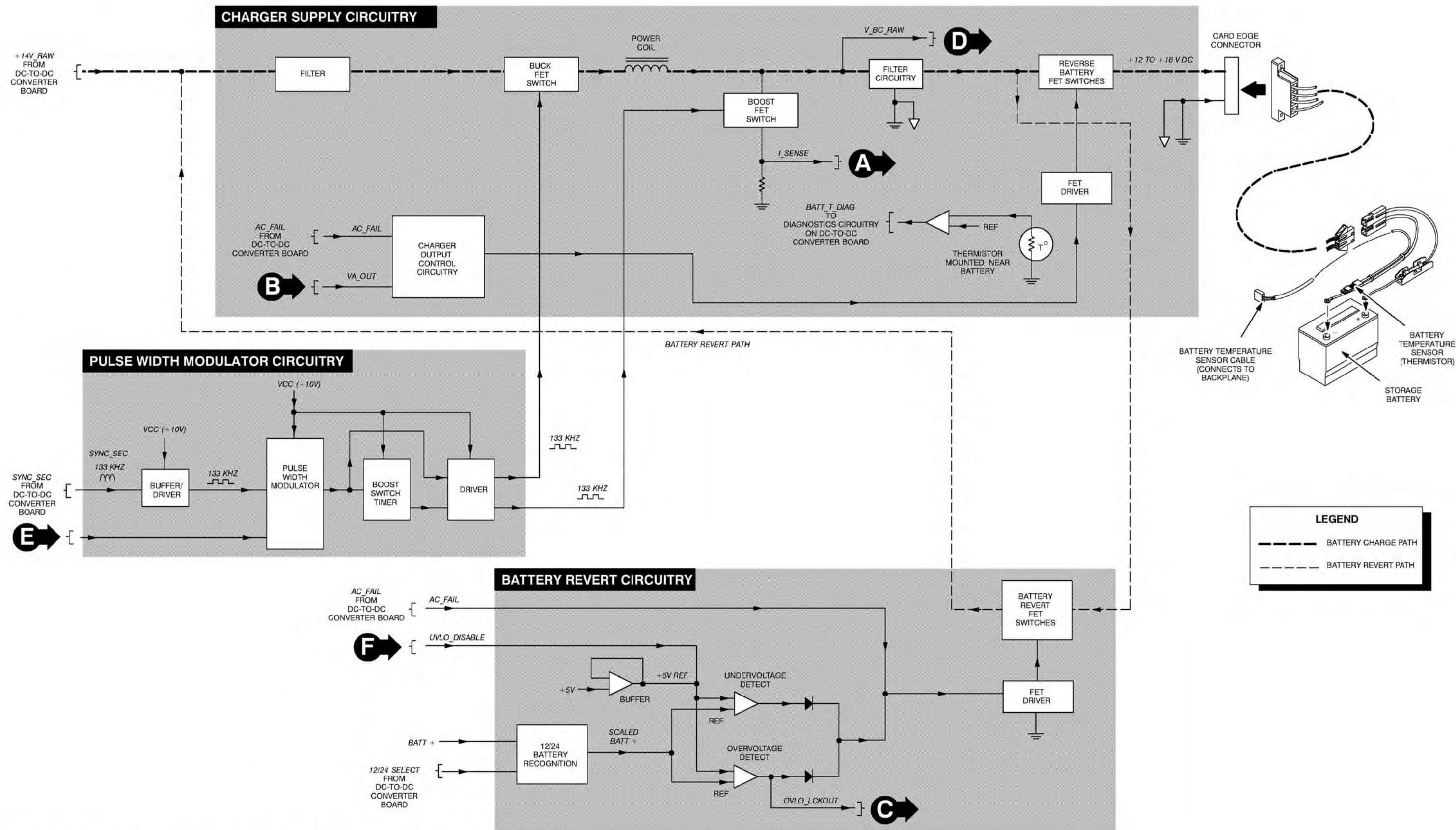

Figure 4. CPN6074C Battery Charger/Revert Board Functional Block Diagram (1 of 2)

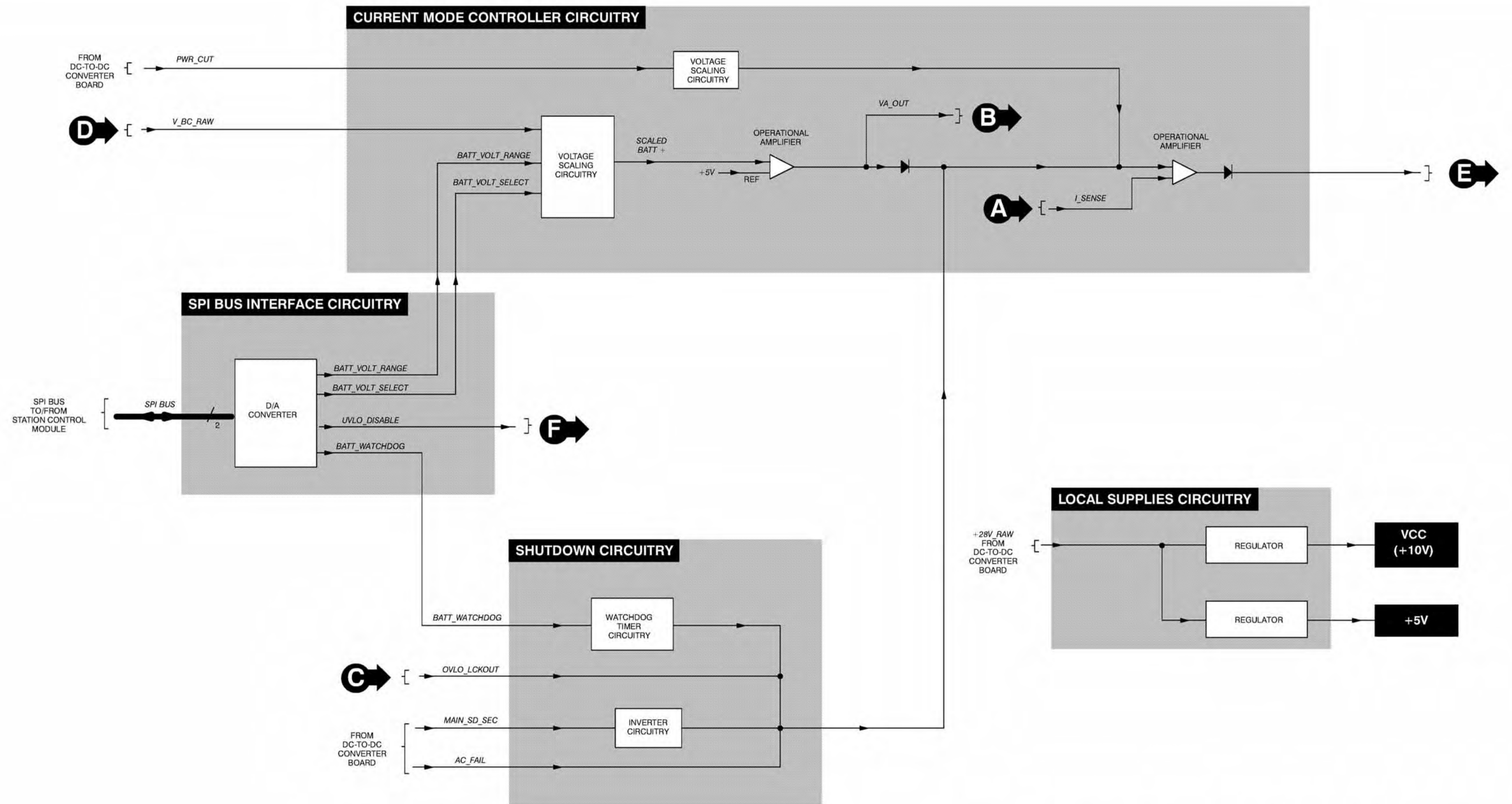

Figure 4. CPN6074C Battery Charger/Revert Board Functional Block Diagram (2 of 2)

**INCLUDES MODELS:****CPN1047A (625W w/o Battery Charger; AC Input)  
CPN1048A (625W with Battery Charger; AC Input)**

# 1 DESCRIPTION

The Models CPN1047A/CPN1048A Power Supply Modules are described in this section. A general description, performance specifications, identification of controls, indicators, and inputs/outputs, a functional block diagram, and functional theory of operation are provided. The information provided is sufficient to give service personnel a functional understanding of the module, allowing maintenance and troubleshooting to the module level. (Refer also to the Maintenance and Troubleshooting section of this manual for detailed troubleshooting procedures for all modules in the station.)

## General Description

The Models CPN1047A/CPN1048A Power Supply Modules each accept an ac input (90–264 V ac, 47–63 Hz) and generate +28.6V dc, +14.2V dc, and +5.1V dc operating voltages to power the station modules. Each power supply module is comprised of three circuit boards which provide several switching-type power supply circuits, power factor correction circuitry, battery charger/revert circuitry (CPN1048A only), and diagnostics and monitoring circuitry, all contained within a slide-in module housing.

The power supply module provides the following features:

- **Auto-ranging for input voltage and frequency** — circuitry automatically adjusts for input ranges of 90–264 V ac and 47–63 Hz; no jumpers, switches, or other settings are required
- **Input transient and EMI protection** — MOV, gas discharge, and filter devices protect the power supply circuitry from ac line voltage transients and electro-magnetic interference
- **Internal voltage and current limiting** — circuitry continually monitors critical voltages and currents and shuts supply down if preset thresholds are exceeded
- **Temperature protection** — module contains built-in cooling fan; supply shuts down if temperature exceeds preset threshold
- **Diagnostic monitoring** — critical internal parameters are continually monitored and reported to the Station Control Module, which can automatically provide correction for certain operating conditions

— continued on next page —

**General Description  
(continued)**

- **Fan Failure Protection** — Power Supply enters shutdown mode in event of cooling fan failure
- **Battery Reverse Polarity Protection** — Charger circuitry is protected against connecting the external battery in reverse polarity (CPN1048 only)
- **Auto Switchover to/from Battery** — If AC input fails, station is automatically switched over to battery operation; when AC input is restored, station is automatically switched back to power supply operation (CPN1048 only)
- **Auto Recovery from Shutdown** — Power Supply automatically recovers from shutdown mode if the cause of the shutdown no longer exists
- **Software-Controlled Battery Charging Voltage** — The battery charging voltage and current is controlled based on the ambient temperature (CPN1048 only)
- **Limited In-Rush Current** — Circuitry limits in-rush current to less than 30 A in all conditions

The Models CPN1047A and CPN1048A differ only in the inclusion of battery charger/revert board (CPN1048A only). Unless otherwise noted, the information provided in this section applies to both models.

**Power Supply Module  
Simplified Block Diagram**

The illustration below provides a simplified block diagram of a Power Supply Module (with battery charger) showing how the three circuit boards interconnect. A detailed block diagram and functional theory of operation for each board is provided later in this section (beginning on page 6).

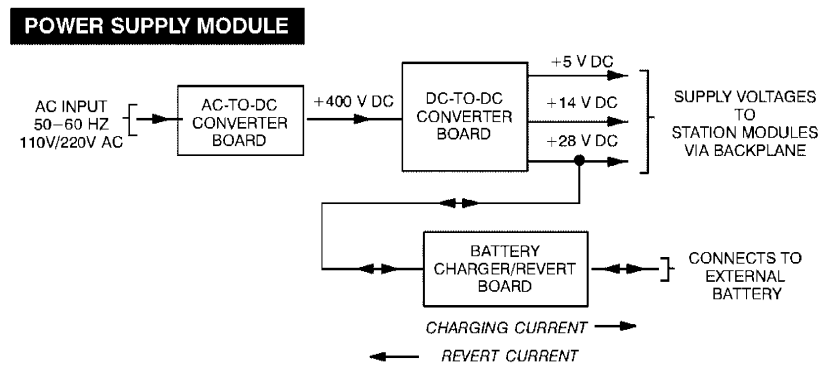

## Overview of Circuitry

The power supply module is comprised of three circuit boards, connected together via cables. These boards contain circuitry as follows:

### **AC-to-DC Converter Board (CPN6065B)**

- **Input Conditioning Circuitry** — consists of ac line transient protection, EMI filtering, front panel on/off switch, startup-delayed relay, and a full-wave rectifier.
- **Startup Delay Circuitry** — provides a delay of approximately 1.5 seconds from time on/off switch is turned on until the power supply becomes functional (allows pre-charge of high-capacity filter capacitors to limit in-rush current on power up).
- **Boost/Power Factor Correction Circuitry** — consists of switching-type power supply that generates +400V dc for use by DC-to-DC Converter Board, as well as providing power factor correction.
- **Battery Revert Trigger Circuitry** — Monitors +400 V dc and generates a signal to the Battery Charger/Revert Board to activate battery revert if the +400 V dc fails or drops below approximately +350 V dc.
- **VCC Supply Circuitry** — consists of switching-type power supply that generates the VCC supply voltage (approximately +13V dc) for use by circuitry on AC-to-DC Converter Board and DC-to-DC Converter Board.

### **DC-to-DC Converter Board (CPN6067A)**

- **+28 V Main Supply Circuitry** — consists of switching-type power supply that generates the +28 V dc supply voltage and provides primary/secondary isolation.
- **+14 V Supply Circuitry** — consists of switching-type power supply that generates the +14 V dc supply voltage (from +28 V dc supply voltage).
- **+5 V Supply Circuitry** — consists of switching-type power supply that generates the +5 V dc supply voltage (from +28 V dc supply voltage).
- **Battery Charger Control Circuitry** — Provides buffering for signals related to battery charging/revert operation.
- **Reference Voltage Circuitry** — Generates +10V\_SEC and +2.5V\_SEC supply voltages for use by local circuitry.
- **Diagnostics Circuitry** — converts analog status signals to digital format for transfer to Station Control Module.
- **Address Decode Circuitry** — performs address decoding to provide chip select signal for the A/D converter.
- **Startup/Shutdown Control Circuitry** — Provides delay intervals for startup and shutdown of entire power supply module.

— continued on next page —

---

## Overview of Circuitry (Continued)

### **Battery Charger/Revert Board (CPN6074B)**

- **Charger Supply Circuitry** — consists of switching-type power supply that generates charging current for the external storage battery.
- **Pulse Width Modulator Circuitry** — consists of pulse-width modulator, boost switch timer, and driver circuitry to provide variable-width pulses for the FET switches in the Charger Supply Circuitry.
- **Battery Revert Circuitry** — consists of signal monitoring circuitry which turns on the Battery Revert FET Switches for certain input signal conditions (such as AC Fail).
- **Current Mode Controller Circuitry** — consists of current and voltage feedback signal monitoring circuitry which controls the Pulse Width Modulator Circuitry to maintain the desired charger output current and voltage.
- **SPI Bus Interface Circuitry** — consists of a D/A converter which accepts charger control digital signals from the Station Control Module and converts these signals to analog dc voltages to control various operating characteristics of the battery charger circuitry.
- **Shutdown Circuitry** — consists of signal monitoring circuitry which shuts down the battery charger for certain input signal conditions (such as loss of BATT\_WATCHDOG signal from the Station Control Module).
- **Local Supplies Circuitry** — Accepts +28V\_RAW (from DC-to-DC Converter Board) and generates VCC (+10V) and +5V supply voltages for use by local circuitry.

## 2 PERFORMANCE SPECIFICATIONS

Table 1 shows the electrical performance specifications for the Models CPN1047A and CPN1048A Power Supply Modules.

### Performance Specifications

**Table 1.** CPN1047A/CPN1048A Power Supply Modules Performance Specifications

Parameter	Specification
Weight	6.5 kg (14.3 lbs)
Operating Temperature Range	-30 to +60° C (no derating)
Input Voltage Range	90 to 264 V ac
Input Frequency Range	47 to 63 Hz
Maximum Input Current	8.5 A
Steady State Output Voltages	+28.6 V dc ±5% +14.2 V dc ±5% +5.0 V dc ±5%
Output Current Ratings	+28.6 12.5 A +14.2 8 A +5.1 3 A
Total Output Power Rating	625W* <i>* including 100W for battery charger</i>
Output Ripple	All outputs 150 mV p-p (measured with 20 MHz BW oscilloscope at 25° C).

### 3 CONTROLS, INDICATORS, AND INPUTS/OUTPUTS

Figure 1 shows the power supply module controls, indicators, and all input and output external connections.

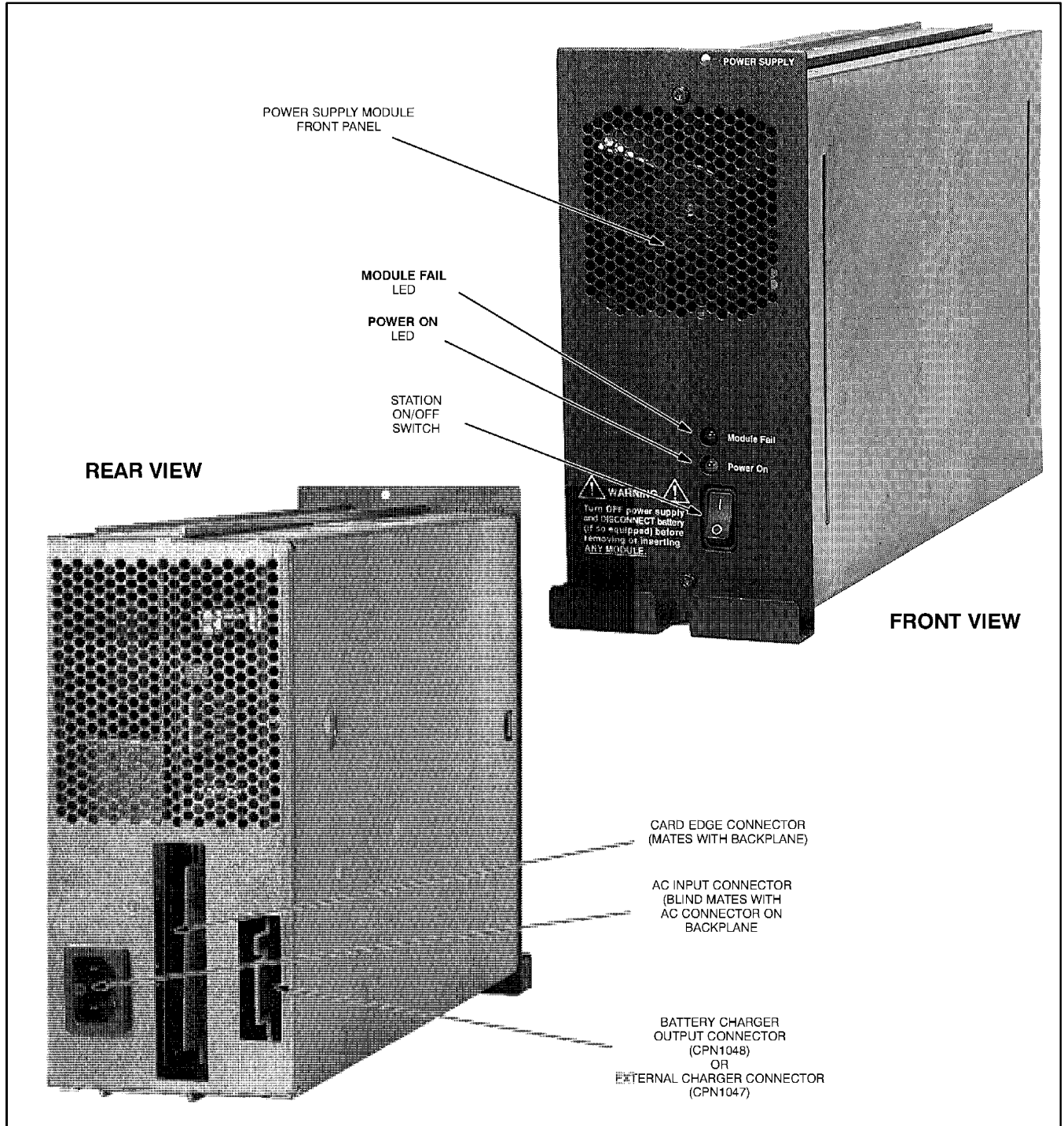

**Figure 1.** CPN1047A/CPN1048A Power Supply Module Controls, Indicators, and Inputs/Outputs



## 4 FUNCTIONAL THEORY OF OPERATION (AC-to-DC Converter Board)

The following theory of operation describes the operation of the CPN6065B AC-to-DC Converter Board circuitry at a functional level. The information is presented to give the service technician a basic understanding of the functions performed by the module in order to facilitate maintenance and troubleshooting to the module level. Refer to Figure 2 for a block diagram of the AC-to-DC Converter Board.

### Input Conditioning Circuitry

#### *Introduction*

The AC-to-DC Converter Board accepts ac power from an external source, typically a 110V or 220/240V ac wall receptacle. AC power is connected to the board via a 3-wire line cord plugged into an ac receptacle mounted on the station backplane, into which the entire power supply module slides (blind mate connection).

#### *Transient and EMI Protection*

The ac line input is fed to the AC-to-DC Converter Board circuitry via transient protection and EMI filter circuits. The transient protection devices provide protection against voltage spikes by providing an effective short to ground under high voltage transient conditions. The EMI filter prevents electrical noise generated by the power supply module from interfering with other equipment connected to the same ac line circuit.

#### *Front Panel On–Off Switch / Relay Circuitry*

A rocker-type switch located on the power supply module front panel allows the power supply (and station) to be turned on and off. Note that the switch allows the filter circuitry (p/o Boost/Power Factor Correction Circuitry) to slowly charge (for approximately 1.5 seconds after switch is turned on) through two diodes and resistors. After the 1.5 second delay, the relay turns on and provides an ac input to the bridge rectifier. This 1.5 second pre-charge delay period limits in-rush current through the filter capacitors upon power up.

#### *Rectifier Circuitry*

The ac line voltage (via the relay) is rectified by a full-wave bridge rectifier and fed to the Boost/Power Factor Correction Circuitry.

### Startup Delay Circuitry

This circuitry monitors the ac input (from the on/off switch) and provides a 1.5 second delay when switch is turn on before energizing the relay to turn on the power supply.

If the AC input is below approximately 85 V rms, the relay will not be turned on and the power supply outputs will be disabled. The red **Module Fail** LED on the front panel will light.

---

## Boost/Power Factor Correction Circuitry

### Overview

The Boost/Power Factor Correction Circuitry is comprised of a switching-type power supply which generates a +400 V dc voltage. This voltage is fed to the DC-to-DC Converter Board to be used as the source for the +28V, +14V, and +5V Supply Circuits.

### Switching Power Supply Operation

The switching power supply consists of a pulse width modulator (PWM) running at 67 kHz. The PWM output pulses are fed through driver transistors to control three power FETs which rapidly switch the Toroid Power Coil to ground. The result is a high induced current which charges the filter capacitors to approximately 400 V dc.

Note that the PWM output pulses are also controlled by voltage and current feedback signals. These feedback signals allow the average ac line current over switching cycles to be sinusoidal and in-phase with the ac input voltage (i.e., power factor corrected).

---

## Battery Revert Trigger Circuitry

A comparator monitors the +400 V dc from the output of the Boost/Power Factor Correction Circuitry and a +5V reference signal. If the +400 V dc voltage should drop below approximately +350 V dc (considered an ac input failure), a BOOST\_LOW signal is sent to the Battery Charger/Revert Board (via the DC-to-DC Converter Board) to activate battery revert mode.

---

## VCC Supply Circuitry

This circuitry consists of a switching-type power supply which generates a +13 V dc supply voltage used as VCC by the local circuitry and the primary side of the DC-to-DC Converter Board.

The circuitry consists of a pulse width modulator (PWM) running at 67 kHz (from DC-to-DC Converter Board). The PWM output repetitively gates the +400 V dc (from the Boost/Power Factor Correction Circuitry) to the primary of the housekeeping transformer. The result is an induced voltage in the secondary winding which feeds a half-wave rectifier circuit. The output is a +13 V dc VCC supply voltage.

---

## LED Status Indicators

Two LEDs located on the power supply module front panel indicate module status as follows:

- **AC On**— lights GREEN when On/Off switch is On and the AC input voltage is within operating range; LED turns off when module is turned off, ac power is removed, or AC input voltage is below approximately 85 V rms.
- **Module Fail**— lights RED when initially turning on or off the Power Supply (this is normal and does not indicate a failure) or when the DC-to-DC Converter Board is not functioning properly; LED turns off when module is functioning properly

**Note** *When in Battery Revert Mode (CPN1048 only), neither LED is lit. The cooling fan will continue to run.*

## 5 FUNCTIONAL THEORY OF OPERATION (DC-to-DC Converter Board)

The following theory of operation describes the operation of the CPN6067A DC-to-DC Converter Board circuitry at a functional level. The information is presented to give the service technician a basic understanding of the functions performed by the module in order to facilitate maintenance and troubleshooting to the module level. Refer to Figure 3 for a block diagram of the DC-to-DC Converter Board.

### +28V Main Supply Circuitry

#### **Overview**

The +28V Main Supply Circuitry is comprised of two mirrored switching-type power supplies which generate the +28 V supply voltage. This voltage is used as the source for the +14V and +5V supply circuits, as well as the +28V supply voltage for the station modules (via the backplane) and

#### **Switching Power Supply Operation**

The +28V Main Supply Circuitry consists of two identical switching-type power supplies operating in parallel. Both supplies operate identically, as follows. A 133 kHz clock signal from the Sync Generator Circuitry is fed through a buffer to a Pulse Width Modulator (PWM). The PWM output pulses control a pair of power FETS (via a driver) to gate the +400 V dc (from the AC-to-DC Converter Board) to the primary of a power transformer. The induced voltage in the transformer secondary is half-wave rectified to charge the output filter circuitry, resulting in an output voltage of +28 V dc.

Since each supply receives a 133 kHz clock signal that is 180° out of phase with the other, each switching power supply alternately charges the output filter circuitry, resulting in an effective charging rate of 266 kHz.

#### **Protection Circuitry**

**Peak/Average Current Limiting Circuitry** — The peak current limiting circuitry accepts an output current feedback signal and a scaled +28V\_RAW reference signal to control the PWMs. This effectively maintains a constant output voltage for varying output current demands.

The average current limiting circuitry monitors the +28 V dc output and generates a shutdown signal (MAIN\_SD\_PRI) if the average output current reaches a predetermined limit.

**Overshoot Protection Circuitry** — This circuitry monitors the +28V output voltage and generates a shutdown signal (MAIN\_SD\_SEC) to shut down the entire power supply module if the +28 V output voltage exceeds a preset threshold.

---

## **+14 V Supply Circuitry**

### **Overview**

The +14 V Supply Circuitry is comprised of a switching-type power supply which generates a +14.2 V dc supply voltage. This voltage is used as the +14.2 V supply voltage for the station modules (via the backplane).

### **Switching Power Supply Operation**

The +14 V switching power supply consists of a pulse width modulator (PWM) running at 133 kHz. The PWM output pulses are fed through a driver to control a power FET which repetitively gates the +28V\_RAW (from the +28V Main Supply Circuitry) to a power coil. The result is a high induced voltage which charges the filter capacitors to approximately +14.2 V dc. A current sense comparator provides a feedback signal to the PWM to maintain a constant output voltage.

### **Protection Circuitry**

An overvoltage detect circuit monitors the output voltage and, if preset thresholds are exceeded, turns on a FET crowbar circuit which immediately discharges the output to protect other modules in the station.

An overcurrent detect circuit monitors the current draw from the +14V Supply Circuitry and, if a preset threshold is exceeded, generates a MAIN\_SD\_SEC signal which shuts down the entire power supply module.

---

## **+5 V Supply Circuitry**

The +5 V Supply Circuitry operates identically to the +14 V Supply Circuitry (described above) to generate a +5.1 V dc supply voltage. This voltage is used as the +5 V supply voltage for the station modules (via the backplane).

---

## Battery Charger Control Circuitry

The POWER\_CUT\_PRI signal (from the Peak/Average Current Detect Circuitry) is buffered and fed to the Battery Charger/Revert Board as POWER\_CUT\_SEC. This signal reduces the current supplied by the battery charger circuitry to divert maximum power to the power supply outputs (+28V, +14V, and +5V) during times of heavy current draw.

The AC\_FAIL signal (from the AC-to-DC Converter Board) is buffered and fed to 1) the diagnostics circuitry as AC\_GOOD\_DIAG, and 2) the Battery Charger/Revert Board as BATTERY\_REVERT. This signal activates battery revert mode.

---

## Reference Voltage Circuitry

This circuitry accepts +28V\_RAW (from the +28V Main Supply Circuitry) and generates +10V\_SEC and +2.5V\_SEC supply voltages for use by local circuitry.

---

## Diagnostics Circuitry

### **Overview**

The diagnostics circuitry consists of an 11-channel A/D converter which converts analog status signals from critical points in the power supply module to digital format for transfer to the Station Control Module via the SPI bus. Most of the status signals are generated by detect circuits to indicate the status of dc supply voltages and references.

### **Temperature Monitor and Control Circuitry**

A thermistor mounted on the power supply module heatsink provides a varying resistance input to the Heatsink Temp Detect Circuitry. If the heatsink temperature exceeds a preset limit, the circuitry generates a MAIN\_SD\_SEC shutdown signal which shuts down the entire power supply module. A HEATSINK\_DIAG signal is also sent to the Station Control Module via the A/D converter and SPI bus.

### **Fan Monitor and Control Circuitry**

The cooling fan in the power supply module is powered from the +14V Supply Circuitry and runs continuously. If the fan fails, the Fan Fault Detect circuit generates a fail signal (FAN\_FAIL\_DIAG) which is fed to the A/D converter. The fail signal also triggers a 50 second delay circuit which (after 50 seconds) generates a MAIN\_SD\_SEC signal which shuts down the entire power supply.

---

## Address Decode Circuitry

The address decode circuitry allows the Station Control Module to use the address bus to select either the D/A converter (Battery Charger/Revert Board) or the A/D converter (Diagnostics Circuitry) for communications via the SPI bus. Typical communications include reading status signals from the Diagnostics Circuitry and providing charger output control signals to the Battery Charger/Revert Board.

---

## Startup/Shutdown Control Circuitry

### **Shutdown Delay Circuitry**

Upon receiving a shutdown signal (MAIN\_SD\_PRI) from the +28V Main Supply Circuitry, this circuit passes the signal through the Soft Start Circuitry for a 1 second interval to allow the entire power supply module to shutdown. The module then restarts (if the on/off switch is in **On** position). If the MAIN\_SD\_PRI signal is still active, the shutdown process will repeat.

### **Startup/Shutdown Delay Circuitry**

When the power supply module is first turned on, the RELAY\_ON signal is low and the output of the Startup/Shutdown Delay Circuitry keeps the supply in shutdown mode. After about 1.5 seconds RELAY\_ON goes high, and the Startup/Shutdown Delay Circuitry provides a 1 second delay before releasing the shutdown signal and allowing the power supply to operate.

When the power supply module is turned off, the RELAY\_ON signal goes low and the Startup/Shutdown Delay Circuitry keeps the supply in operating mode for 1 second to allow Battery Revert Mode to activate.

### **Soft Start Circuitry**

Each time the Soft Start Circuitry receives a startup signal (i.e., MAIN\_SD\_PRI is inactive and the output of the Startup/Shutdown Delay Circuitry is high), the Soft Start Circuitry provides a gradually increasing output signal to “soft start” the Pulse Width Modulators (p/o +28V Main Supply Circuitry). This action minimizes the surge current when charging the output filter capacitors.

## 6

## FUNCTIONAL THEORY OF OPERATION (Battery Charger/Revert Board)

The following theory of operation describes the operation of the CPN6074B Battery Charger/Revert Board circuitry at a functional level. The information is presented to give the service technician a basic understanding of the functions performed by the module in order to facilitate maintenance and troubleshooting to the module level. Refer to Figure 4 for a block diagram of the Battery Charger/Revert Board.

**Note** Model CPN1047A Power Supply Modules (without battery charging capabilities) are equipped with a CPN6078A External Charger Connect Board in place of the CPN6074B Battery Charger/Revert Board. The External Charger Connect Board provides a direct electrical path from the +28V Main Supply Circuitry (p/o the DC-to-DC Converter Board) to the card edge connector used to connect to an external charger and battery. The external charger is responsible for 1) charging the external battery and 2) detecting an AC power fail condition and initiating battery revert mode.

### Charger Supply Circuitry

#### Overview

The Charger Supply Circuitry is comprised of a switching-type power supply which generates the charging current necessary to charge an external storage battery.

#### Switching Power Supply Operation

The charger switching power supply accepts +28V (from the DC-to-DC Converter Board) which is fed through a filter and a Buck FET Switch to a Power Coil. This coil is controlled by the Buck FET Switch and a Boost FET Switch to produce an induced output voltage of approximately +21 to +31 V dc. This charging voltage is filtered and fed through a pair of Reverse Battery FET Switches to the output terminals (card edge connector that extends from the rear of the Power Supply Module). Connections to an external storage battery are made to this card edge connector.

Protection against connecting the battery in reverse polarity is provided by the Charger Output Control Circuitry and the Reverse Battery FET Switches.

A thermistor mounted near the battery and connected to the station via a backplane connector provides an input to a comparator. The comparator output (BATT\_T\_DIAG) provides a dc voltage proportional to the battery temperature. This signal is sent to the Station Control Module via the Diagnostics Circuitry on the DC-to-DC Converter Board.



---

## Pulse Width Modulator Circuitry

A 133 kHz clock signal (from the DC-to-DC Converter Board) is fed through a buffer/driver to a Pulse Width Modulator (PWM). The 133 kHz PWM output pulses are fed 1) directly to the Buck FET Switch via a driver, and 2) to the Boost FET Switch via a Boost Switch Timer and Driver. The two signals control the respective FET switches to control the Power Coil in the Charger Supply Circuitry so that it produces an approximately +21 to +31 V dc output to be filtered and charge the external battery.

---

## Battery Revert Circuitry

### Overview

The Battery Revert Circuitry accepts various inputs and determines when to activate battery revert mode by turning on the Battery Revert FET Switches. Battery Revert Mode will be activated or deactivated in the following conditions:

- If the AC\_FAIL signal (from the DC-to-DC Converter Board) goes low (indicating that AC power has failed), the Battery Revert FET Switches will be turned on (via the FET Driver).
- If the battery voltage is too low, the Undervoltage Detect circuit detects the condition and disables the battery revert circuitry.
- If the battery voltage is too high, the Overvoltage Detect circuit detects the condition and disables the battery charger and the battery revert circuitry.
- If a fault condition exists (e.g., +5V Overcurrent), the shutdown detect circuitry detects the condition and disables the battery charger and the battery revert circuitry.

---

## Current Mode Controller Circuitry

### Overview

The Current Mode Controller Circuitry performs two major functions:

- The PWR\_CUT signal (from the DC-to-DC Converter Board) is fed through a Voltage Scaling Circuit and reduces the battery charger output current during periods of heavy current draw by the station.
- The Voltage Scaling Circuitry accepts V\_BC\_RAW (voltage feedback signal from battery) and BATT\_VOLT\_RANGE and BATT\_VOLT\_SELECT signals (from the Station Control Module via the D/A Converter) which combine to set the charger output voltage (in a range of +21 V dc to +31 V dc).

---

## SPI Bus Interface Circuitry

This circuitry consists of a D/A Converter that accepts digital signals from the Station Control Module and converts them to analog signals which control the operation of the Battery Charger/Revert Board. These signals:

- Control the charger voltage to the battery (BATT\_VOLT\_RANGE and BATT\_VOLT\_SELECT)
- Disable the Undervoltage Detect Circuitry (UVLO\_DISABLE) to allow the station to continue operation even though the battery voltage is below the desired level
- Provide a watchdog signal to refresh the Watchdog Timer Circuitry (BATT\_WATCHDOG)

---

## Shutdown Circuitry

This circuitry accepts four input signals and generates a shutdown signal to shut down the battery charger for certain input signal conditions. A shutdown signal will be generated for any of the following conditions:

- The BATT\_WATCHDOG signal (from the Station Control Module) is not present (indicating that the Station Control Module has failed, or the station's *Battery Type* field has been programmed (via RSS) for "NONE")
- The OVLO\_LCKOUT signal is high (indicating that the battery voltage is too high)
- The MAIN\_SD\_SEC signal is low (indicating that one of the various monitoring points indicates a fault, such as overcurrent condition for +14V or +5 V supplies, overcurrent condition for entire Power Supply Module, etc.)
- The AC\_FAIL signal is high (indicating that the AC power to the Power Supply Module has been interrupted)

---

## Local Supplies Circuitry

This circuitry contains two voltage regulators which accept +28V\_RAW (from the +28V Main Supply Circuitry) and generate VCC (+10 V dc) and +5 V supply voltages for use by local circuitry.

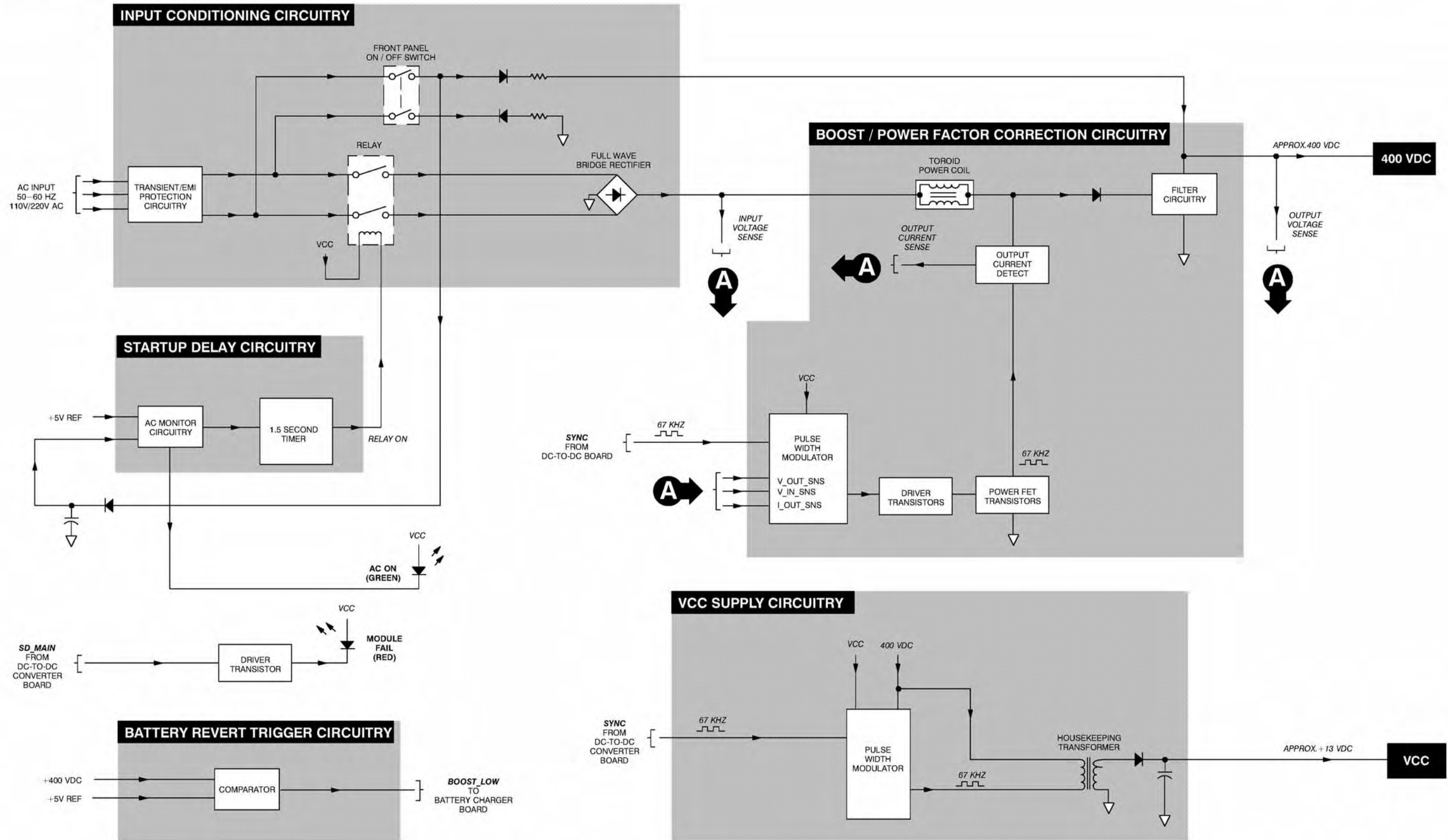

Figure 2. CPN6065B AC-to-DC Converter Board Functional Block Diagram

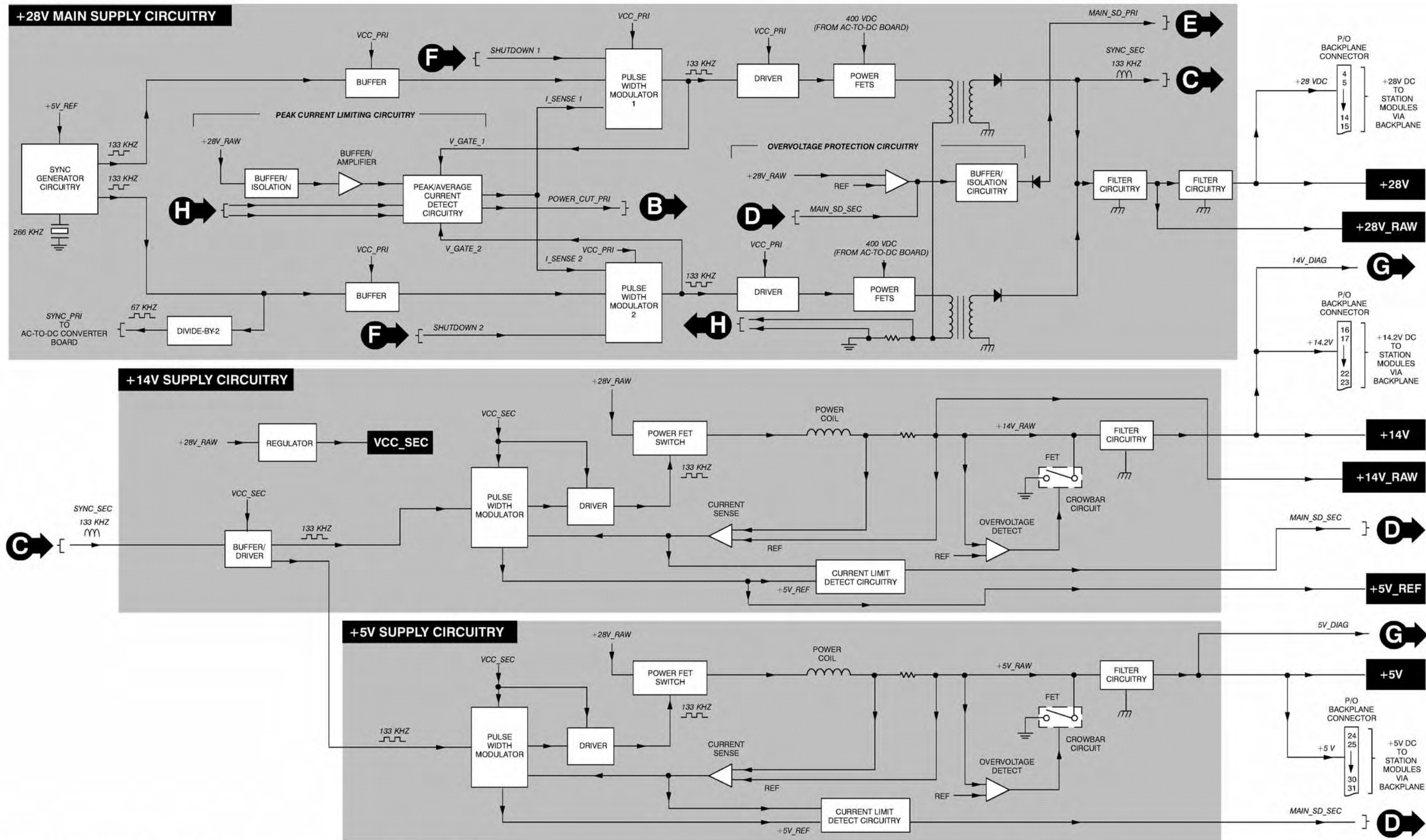

Figure 3. CPN6067A DC-to-DC Converter Board Functional Block Diagram (1 of 2)

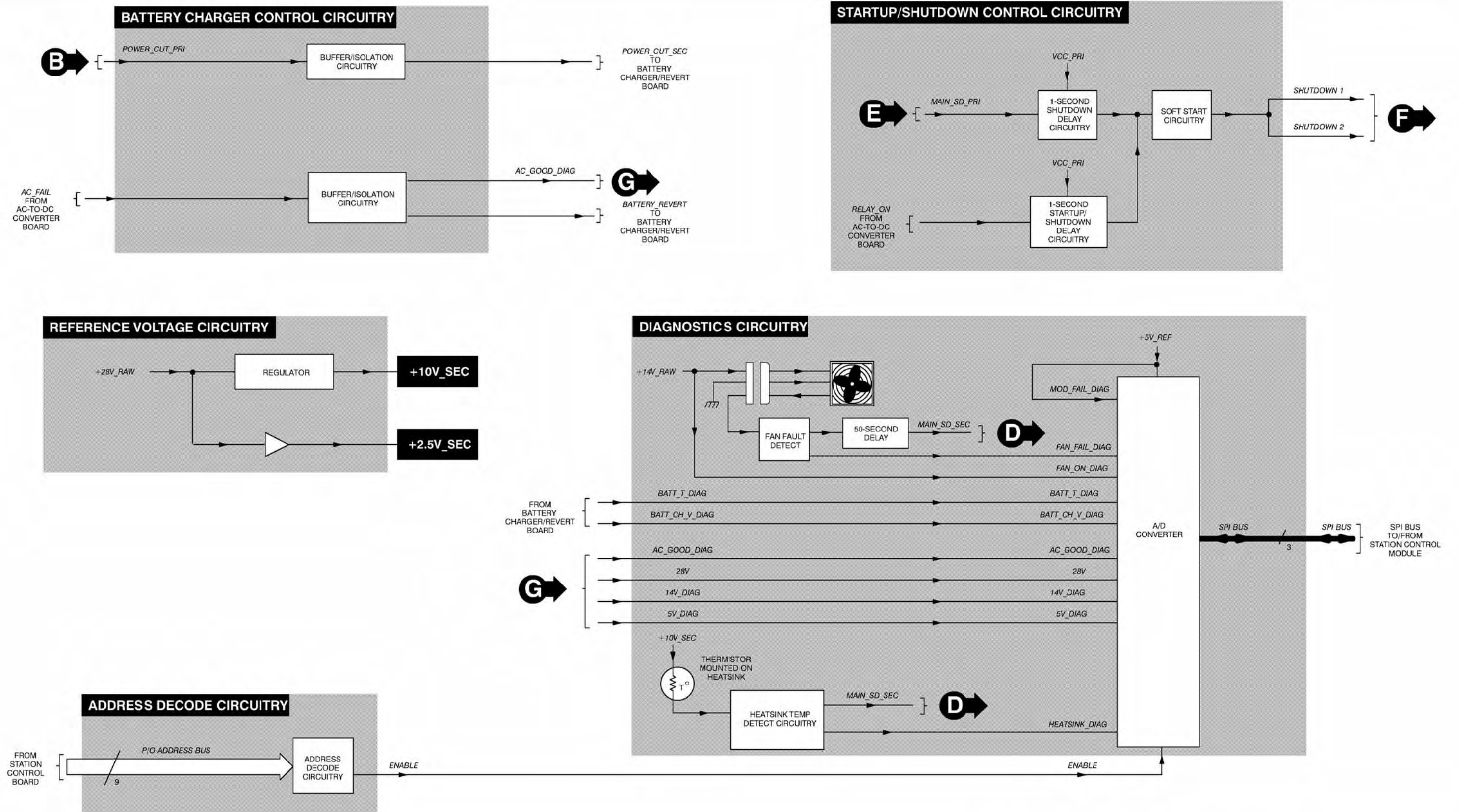

Figure 3. CPN6067A DC-to-DC Converter Board Functional Block Diagram (2 of 2)

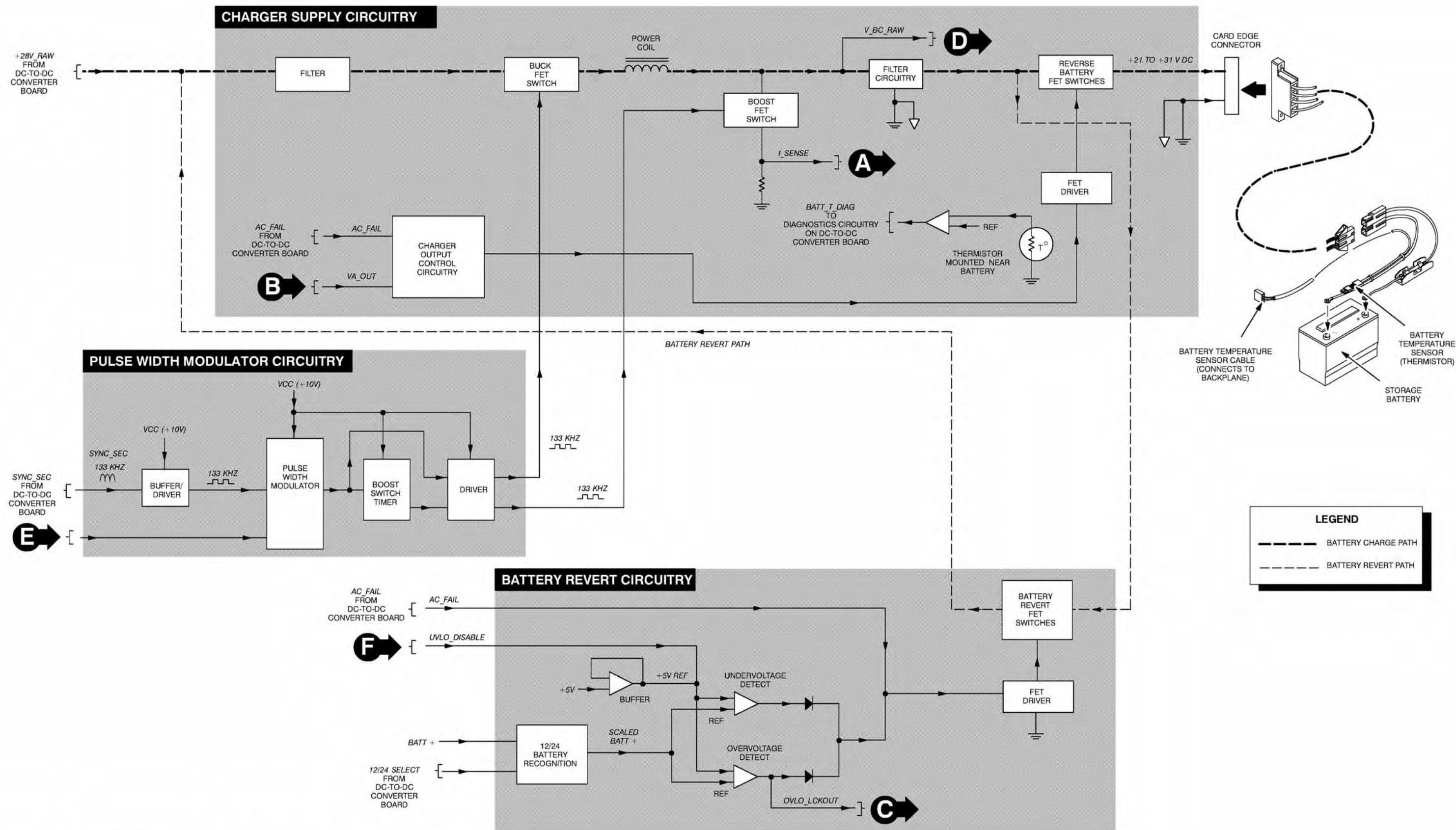

Figure 4. CPN6074B Battery Charger/Revert Board Functional Block Diagram (1 of 2)

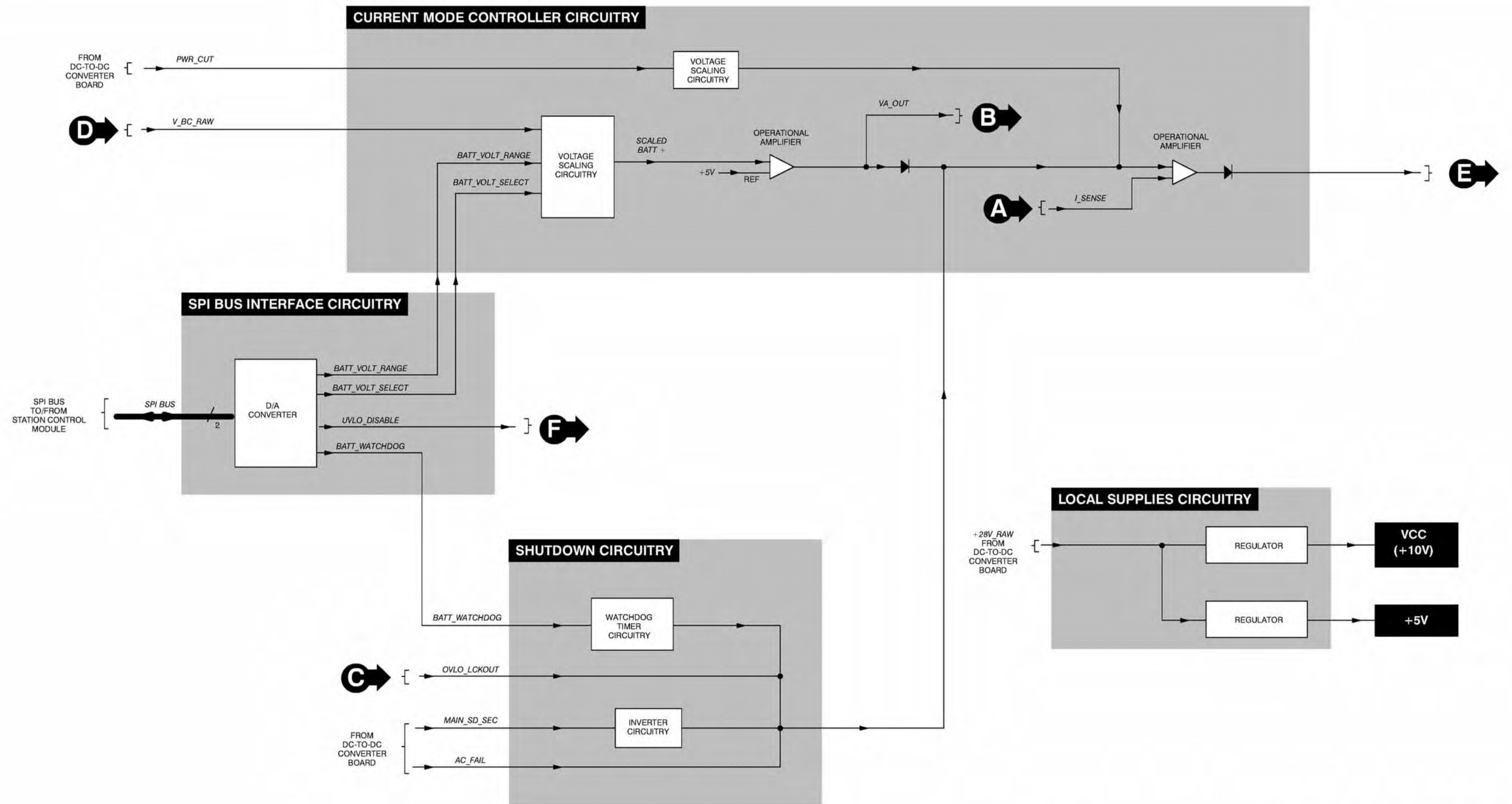

Figure 4. CPN6074B Battery Charger/Revert Board Functional Block Diagram (2 of 2)

**INCLUDES MODELS:  
TRN7802A (210W; 12/24V DC Input)  
TRN7803A (210W; 48/60V DC Input)**

## **1** DESCRIPTION

The Models TRN7802A/TRN7803A Power Supply Modules are described in this section. A general description, performance specifications, identification of controls, indicators, and inputs/outputs, a functional block diagram, and functional theory of operation are provided. The information provided is sufficient to give service personnel a functional understanding of the module, allowing maintenance and troubleshooting to the module level. (Refer also to the Maintenance and Troubleshooting section of this manual for detailed troubleshooting procedures for all modules in the satellite receiver or station.)

### **General Description**

The Model TRN7802A Power Supply Module accepts an input of either 12 V dc or 24 V dc, while the Model TRN7803A Power Supply Module accepts an input of either 48 V dc or 60 V dc. Each module generates +5V dc and +14.2V dc operating voltages to power the satellite receiver or station modules. Each power supply module is comprised of several switching-type power supply circuits and diagnostics and monitoring circuitry, all contained within a slide-in module housing.

The power supply module provides the following features:

- Internal voltage and current limiting — circuitry continually monitors critical voltages and currents and shuts supply down if preset thresholds are exceeded
- Temperature protection — module contains built-in cooling fan which is thermostatically controlled; supply shuts down if temperature exceeds preset threshold
- Diagnostic monitoring — critical internal parameters are continually monitored and reported to the Station Control Module, which can automatically provide correction for certain operating conditions
- Front panel On/Off switch with built-in circuit breaker (30A for TRN7802A, 10A for TRN7803A)

The Models TRN7802A and TRN7803A differ only in the required dc input voltage. Unless otherwise noted, the information provided in this section applies to both models.



# 1 DESCRIPTION (Continued)

---

## Overview of Circuitry

The power supply module contains the following circuitry:

- Startup Inverter Circuitry — provides VCC for power supply circuitry during initial power-up
- Main Inverter Circuitry — consists of switching-type power supply that generates the +14.2V dc supply voltage
- +5 V Inverter Circuitry — consists of switching-type power supply that generates the +5 dc supply voltage
- Clock Generator Circuitry — generates 267 kHz and 133 kHz clock signals used by pulse width modulators in the three inverter circuits
- Diagnostics Circuitry — converts analog status signals to digital format for transfer to Station Control Module
- Address Decode Circuitry — performs address decoding to provide chip select signals for the A/D and D/A converters

## 2 PERFORMANCE SPECIFICATIONS

Table 1 shows the electrical performance specifications for the Models TRN7802A and TRN7803A Power Supply Modules.

### Performance Specifications

**Table 1.** TRN7802A/TRN7803A Power Supply Modules Performance Specifications

Parameter	Specification
Weight	6.5 kg (14.3 lbs)
Operating Temperature Range	-30 to +60° C
Input Voltage Range	TRN7802A 10.5 – 34.5 V dc TRN7803A 41 – 72 V dc
Maximum Input Current	8.5 A
Steady State Output Voltages	+14.2 V dc ±5% +5.1 V dc ±5%
Output Current Ratings	+14.2 12.5 A +5.1 9 A
Total Output Power Rating	no derating 225 W
Output Ripple	All outputs 50 mV p-p (measured with 20 MHz BW oscilloscope at 25° C).  High Frequency individual harmonic voltage limits in 10 kHz-100 MHz frequency band:  14.2 V 1.5 mV p-p 5V 5 mV p-p
Short Circuit Current	0.5 A avg. max

### 3 CONTROLS, INDICATORS, AND INPUTS/OUTPUTS

Figure 1 shows the power supply module controls, indicators, and all input and output external connections.

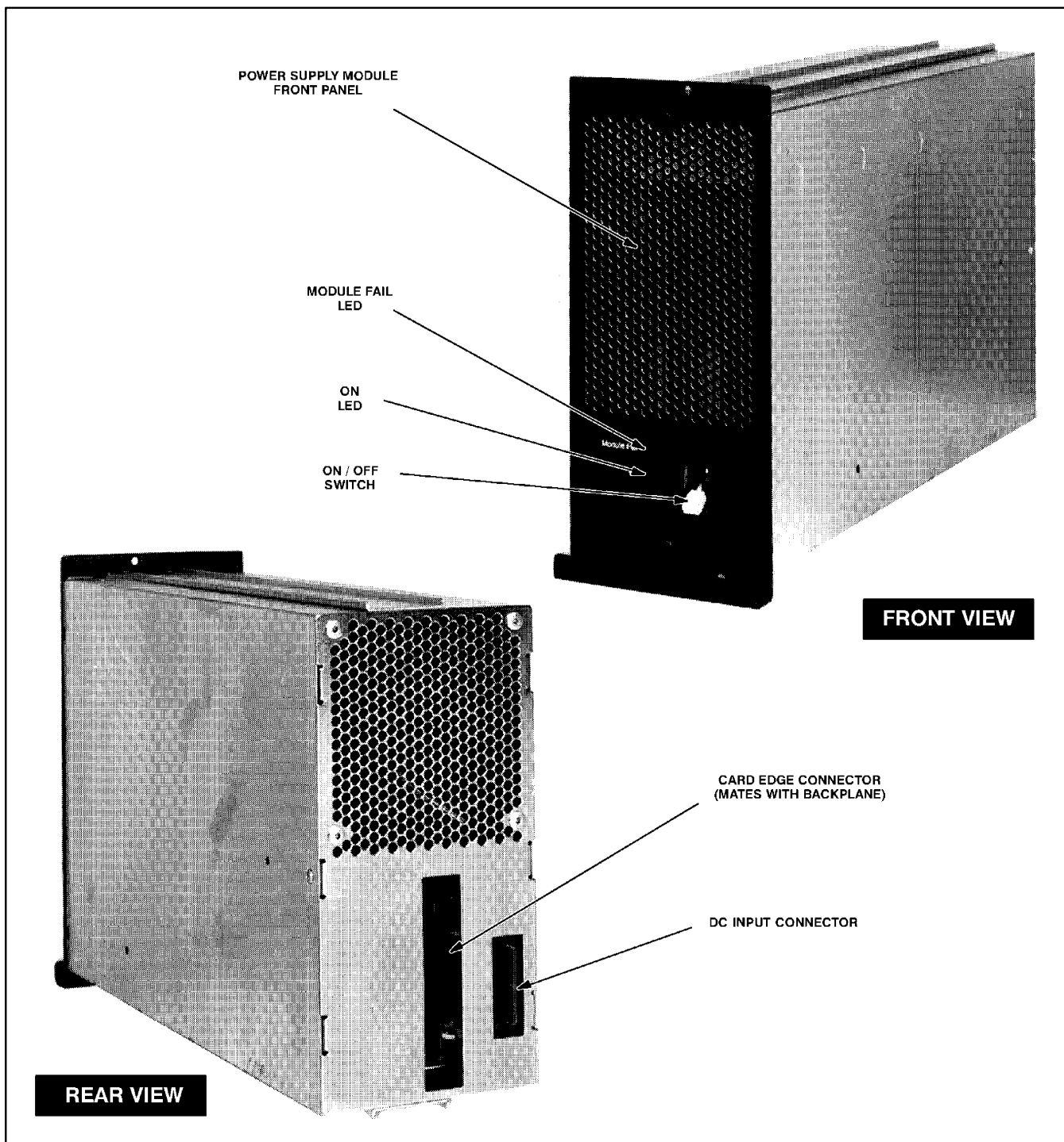

Figure 1. Power Supply Module Controls, Indicators, and Inputs/Outputs

## 4 FUNCTIONAL THEORY OF OPERATION

The following theory of operation describes the operation of the power supply circuitry at a functional level. The information is presented to give the service technician a basic understanding of the functions performed by the module in order to facilitate maintenance and troubleshooting to the module level. Refer to Figure 2 for a block diagram of the power supply module.

### Input Conditioning Circuitry

#### *Introduction*

The power supply module accepts dc power from an external source, typically a bank of storage batteries. DC power is connected to the module via a 4-wire dc input cable mounted on the satellite receiver or station backplane.

#### *Transient and EMI Protection*

The dc input is fed to the power supply module circuitry via transient protection and EMI filter circuits. The transient protection devices provide protection against voltage spikes by providing an effective short to ground under high voltage transient conditions. The EMI filter prevents electrical noise generated by the power supply module from interfering with other equipment connected to the same dc source.

#### *Front Panel On–Off Switch and Breaker*

A toggle-type switch located on the power supply module front panel allows the power supply (and satellite receiver or station) to be turned off by removing the dc input voltage. The switch controls a built-in circuit breaker (rated at 30A for TRN7802A, 10A for TRN7803A) to provide overload protection for the power supply and satellite receiver or station circuitry.

### Startup Inverter Circuitry

This circuitry consists of a switching-type power supply which generates a +12 V dc supply voltage used by the power supply module circuitry as VCC at the time of initial power up. When all supply voltages have stabilized, this circuit is overridden by +14.2 V BULK which continues to supply VCC to the module circuitry.

The circuitry consists of a pulse width modulator (PWM) running at 133 kHz (internal circuitry provides clock signal during initial power up). The PWM output pulses control a transistor switch which repetitively gates voltage (divided down 400 V dc from the Input Conditioning Circuitry) to the primary of the startup isolation transformer. The result is an induced voltage in the secondary winding which feeds two half-wave rectifier circuits. One circuit provides the +12 V dc Startup Bias voltage (used by the module circuitry as initial VCC), and the other provides a BULK DETECT signal used by the Diagnostics Circuitry to generate the DC FAIL signal.

---

## Main Inverter Circuitry

### **Overview**

The main inverter circuitry is comprised of a switching-type power supply which generates a +14.2 V dc supply voltage. This voltage is used as the source for the +5 V inverter circuit in the power supply module, as well as the +14.2 V supply voltage for the satellite receiver or station modules (via the backplane).

### **Switching Power Supply Operation**

The main inverter switching power supply consists of a pulse width modulator (PWM) running at 67 kHz. The PWM output pulses control a power FET bridge which alternately gate the input dc voltage (from the Input Conditioning Circuitry) to the primary of the main isolation transformer. The result is an induced voltage in the secondary windings of the transformer at 133 kHz rate.

### **Transformer Secondary Voltages**

The main isolation transformer has two secondary windings, as follows:

- **Module Fail Winding** — operates in conjunction with a half-wave rectifier circuit to provide a dc signal (Mod Fail) to the A/D converter (p/o Diagnostics Circuitry); indicates that the main inverter circuitry is functioning properly.
- **+14.2 V Winding** — operates in conjunction with a full-wave rectifier circuit to generate a +14.2 V dc supply voltage. Overcurrent and overvoltage detect circuits monitor the circuit operation and, if preset thresholds are exceeded, generate a shutdown signal which is fed to the softstart circuitry to shutdown the main inverter.

---

## +5 V Inverter Circuitry

### **Overview**

The +5 V inverter circuitry is comprised of a switching-type power supply which generates a +5 V dc supply voltage. This voltage is used as the +5 V supply voltage for the satellite receiver or station modules (via the backplane).

### **Switching Power Supply Operation**

The +5 V inverter switching power supply consists of a pulse width modulator (PWM) running at 133 kHz. The PWM output pulses control a power FET which repetitively gates the +14.2 V dc (from the Main Inverter Circuitry) to the filtering circuitry. The result is a +5 V dc supply voltage.

### **Protection Circuitry**

An overvoltage detect circuit monitors the output voltage and, if preset thresholds are exceeded, generates a shutdown signal which is fed to the softstart circuitry to shutdown the main inverter. Upon an overvoltage detection, a FET crowbar circuit immediately discharges the output to protect other modules in the satellite receiver or station.

An overcurrent detect circuit monitors the current draw from the +5 V inverter circuit and, if a preset threshold is exceeded, shuts down the +5 V inverter. If the overcurrent condition lasts for a preset length (approx. 50 msec), the surge current delay circuit generates a shutdown signal which is fed to the softstart circuitry to shutdown the main inverter.

---

## Diagnostics Circuitry

**Note:** The cooling fan in the Power Supply Module is thermostatically controlled and may come on at any time during satellite receiver or station operation. Failure of the fan to rotate continuously does not indicate a failure of the module.

### Overview

The diagnostics circuitry consists of a 11-channel A/D converter which converts analog status signals from critical points in the module to digital format for transfer to the Station Control Module via the SPI bus. Most of the status signals are generated by detect circuits to indicate the status of dc supply voltages and references.

### Temperature Monitor and Control Circuitry

A thermistor mounted on the power supply module heatsink provides a varying resistance input to several detect and control circuits, as follows:

- **Heatsink Status Detect** — compares signal from thermistor to reference voltage to generate an output proportional to heatsink temperature; signal is sent to Station Control Board via A/D converter and SPI bus.
- **Hi-Temp Detect** — compares signal from thermistor to reference voltage to generate a high temperature signal if preset threshold is exceeded; signal is sent to softstart circuitry to shut down main inverter if overtemperature condition is detected.
- **Fan Control Circuitry**— compares signal from thermistor to reference voltage to generate a fan control signal to turn on cooling fan mounted in power supply module; also generated is a FAN ON status signal which is sent to Station Control Board via A/D converter and SPI bus.

Note that a Fan Fault Detect circuit accepts a pulsed feedback signal from the cooling fan to indicate whether the fan is functioning (when turned on by Fan Control Circuitry); a FAN FAIL status signal is sent to Station Control Board via A/D converter and SPI bus

### Status LED Indicators

Two LEDs located on the power supply module front panel indicate module status as follows:

- **On**— lights GREEN when power supply module is turned on and functioning properly; LED turns off when module is turned off, input power is removed, or module startup circuitry is in fail mode
- **Module Fail**— lights RED when power supply module is in fail mode, or when a failure in another station module causes excessive current drain on any of the power supply output voltages; LED turns off when module is functioning properly

---

## Address Decode Circuitry

The address decode circuitry allows the Station Control Board to use the address bus to select the A/D converter (Diagnostics Circuitry) for communications via the SPI bus. Typical communications include reading status signals from the Diagnostics Circuitry.





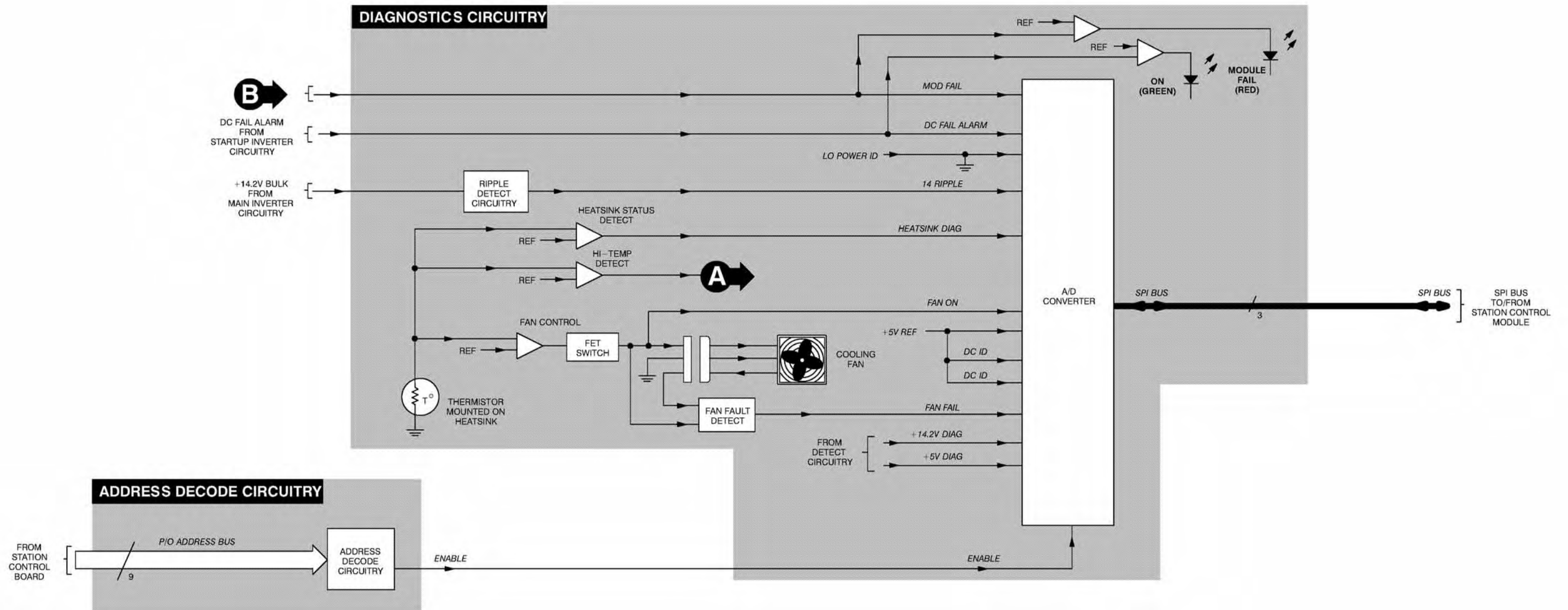

Figure 2. 210W DC/DC Power Supply Module Functional Block Diagram (Sheet 2 of 2)

## 1 DESCRIPTION

The Model TRN7801A Power Supply Module is described in this section. A general description, performance specifications, identification of controls, indicators, and inputs/outputs, a functional block diagram, and functional theory of operation are provided. The information provided is sufficient to give service personnel a functional understanding of the module, allowing maintenance and troubleshooting to the module level. (Refer also to the Maintenance and Troubleshooting section of this manual for detailed troubleshooting procedures for all modules in the station.)

### General Description

The Model TRN7801A Power Supply Module accepts an input of 24 V dc and generates +28.6V dc, +5V dc, and +14.2V dc operating voltages to power the station modules. The power supply module is comprised of several switching-type power supply circuits and diagnostics and monitoring circuitry, all contained within a slide-in module housing.

The power supply module provides the following features:

- **Internal voltage and current limiting** — circuitry continually monitors critical voltages and currents and shuts supply down if preset thresholds are exceeded
- **Temperature protection** — module contains built-in cooling fan which is thermostatically controlled; supply shuts down if temperature exceeds preset threshold
- **Diagnostic monitoring** — critical internal parameters are continually monitored and reported to the Station Control Module, which can automatically provide correction for certain operating conditions
- Front panel On/Off switch with built-in 50A circuit breaker

# 1 DESCRIPTION (Continued)

---

## Overview of Circuitry

The power supply module contains the following circuitry:

- Startup Inverter Circuitry — provides VCC for power supply circuitry during initial power-up
- Main Inverter Circuitry — consists of switching-type power supply that generates the +28V dc supply voltage
- +14.2 V Inverter Circuitry — consists of switching-type power supply that generates the +14.2V dc supply voltage
- +5 V Inverter Circuitry — consists of switching-type power supply that generates the +5 dc supply voltage
- Clock Generator Circuitry — generates 67 kHz and 133 kHz clock signals used by pulse width modulators in the four inverter circuits
- Diagnostics Circuitry — converts analog status signals to digital format for transfer to Station Control Module
- Address Decode Circuitry — performs address decoding to provide chip select signals for the A/D and D/A converters

## 2 PERFORMANCE SPECIFICATIONS

Table 1 shows the electrical performance specifications for the Model TRN7801A Power Supply Module.

### Performance Specifications

**Table 1.** TRN7801A Power Supply Module  
Performance Specifications

Parameter	Specification
Weight	6.5 kg (14.3 lbs)
Operating Temperature Range	–30 to +45° C (no derating) –30 to +60° C (derated)
Input Voltage Range	21.0– 34.5 V dc
Maximum Input Current	40A
Steady State Output Voltages	+28.6 V dc ±5% @ 16A +28.6 V dc ±5% @ 12.8A (derated) +14.2 V dc ±5% @ 9A +5.1 V dc ±5% @ 9A
Output Current Ratings	+28.6                    16A +14.2                    9A +5.0                      9A
Total Output Power Rating	no derating            630 W derated                 540 W
Output Ripple	All outputs 50 mV p–p (measured with 20 MHz BW oscilloscope at 25° C).  High Frequency individual harmonic voltage limits in 10 kHz–100 MHz frequency band:  28.6V   1.5 mV p–p 14.2 V   3.0 mV p–p 5V      5.0 mV p–p
Short Circuit Current	0.5 A avg. max

### 3 CONTROLS, INDICATORS, AND INPUTS/OUTPUTS

Figure 1 shows the power supply module controls, indicators, and all input and output external connections.

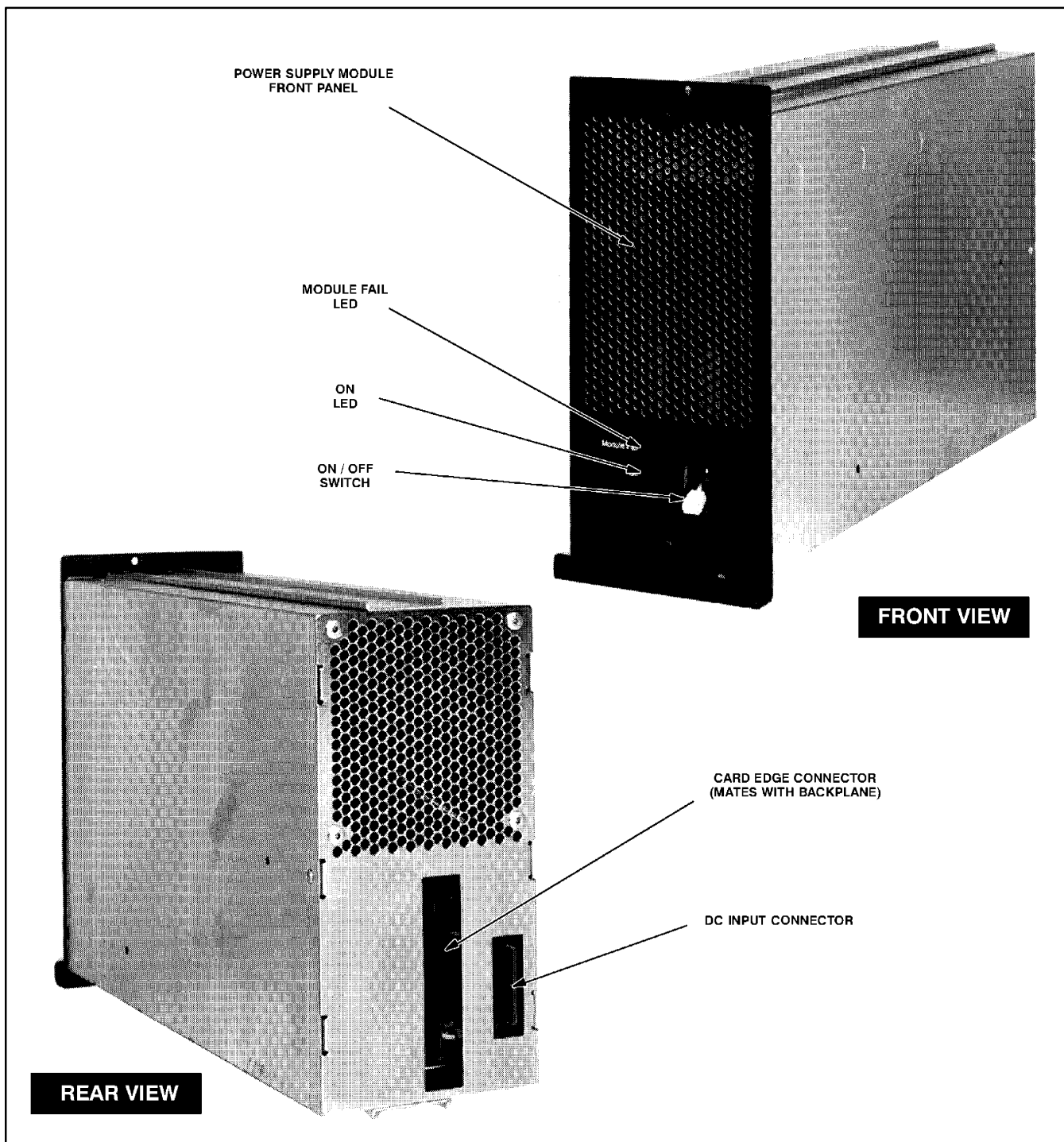

Figure 1. Power Supply Module Controls, Indicators, and Inputs/Outputs

## 4 FUNCTIONAL THEORY OF OPERATION

The following theory of operation describes the operation of the power supply circuitry at a functional level. The information is presented to give the service technician a basic understanding of the functions performed by the module in order to facilitate maintenance and troubleshooting to the module level. Refer to Figure 2 for a block diagram of the power supply module.

### Input Conditioning Circuitry

#### *Introduction*

The power supply module accepts dc power from an external source, typically a bank of storage batteries. DC power is connected to the module via a 4-wire dc input cable mounted on the station backplane.

#### *Transient and EMI Protection*

The dc input is fed to the power supply module circuitry via transient protection and EMI filter circuits. The transient protection devices provide protection against voltage spikes by providing an effective short to ground under high voltage transient conditions. The EMI filter prevents electrical noise generated by the power supply module from interfering with other equipment connected to the same dc source.

#### *Front Panel On–Off Switch*

A toggle-type switch located on the power supply module front panel allows the power supply (and satellite receiver) to be turned off by removing the dc input voltage. The switch controls a built-in circuit breaker (rated at 50A) to provide overload protection for the power supply and station circuitry.

### Startup Inverter Circuitry

This circuitry consists of a switching-type power supply which generates a +12 V dc supply voltage used by the power supply module circuitry as VCC at the time of initial power up. When all supply voltages have stabilized, this circuit is overridden by +14.2 V BULK which continues to supply VCC to the module circuitry.

The circuitry consists of a pulse width modulator (PWM) running at 133 kHz (internal circuitry provides clock signal during initial power up). The PWM output pulses control a transistor switch which repetitively gates voltage to the primary of the startup isolation transformer. The result is an induced voltage in the secondary winding which feeds two half-wave rectifier circuits. One circuit provides the +12 V dc Startup Bias voltage (used by the module circuitry as initial VCC), and the other provides a BULK DETECT signal used by the Diagnostics Circuitry to generate the AC FAIL signal.

---

## Main Inverter Circuitry

### **Overview**

The main inverter circuitry is comprised of a switching-type power supply which generates a +28.6 V dc supply voltage. This voltage is used as the source for the +14.2 V and +5 V inverter circuits in the power supply module, as well as the +28 V supply voltage for the station modules (via the backplane).

### **Switching Power Supply Operation**

The main inverter switching power supply consists of a pulse width modulator (PWM) running at 67 kHz. The PWM output pulses control a power FET bridge which alternately gate the input dc voltage (from the Input Conditioning Circuitry) to the primary of the main isolation transformer. The result is an induced voltage in the secondary windings of the transformer at 133 kHz rate.

### **Transformer Secondary Voltages**

The main isolation transformer has two secondary windings, as follows:

- **Module Fail Winding** — operates in conjunction with a half-wave rectifier circuit to provide a dc signal (Mod Fail) to the A/D converter (p/o Diagnostics Circuitry); indicates that the main inverter circuitry is functioning properly.
- **+28 V Winding** — operates in conjunction with a full-wave rectifier circuit to generate a +28 V dc supply voltage. Overcurrent and overvoltage detect circuits monitor the circuit operation and, if preset thresholds are exceeded, generate a shutdown signal which is fed to the softstart circuitry to shutdown the main inverter.

---

## +14.2 V Inverter Circuitry

### **Overview**

The +14.2 V inverter circuitry is comprised of a switching-type power supply which generates a +14.2 V dc supply voltage. This voltage is used as the +14.2 V supply voltage for the station modules (via the backplane).

### **Switching Power Supply Operation**

The +14.2 V inverter switching power supply consists of a pulse width modulator (PWM) running at 133 kHz. The PWM output pulses control a power FET which repetitively gates the +28.6 V dc (from the Main Inverter Circuitry) to the filtering circuitry. The result is a +14.2 V dc supply voltage.

### **Protection Circuitry**

An overvoltage detect circuit monitors the output voltage and, if preset thresholds are exceeded, generates a shutdown signal which is fed to the softstart circuitry to shutdown the main inverter. Upon an overvoltage detection, a FET crowbar circuit immediately discharges the output to protect other modules in the station.

An overcurrent detect circuit monitors the current draw from the +14.2 V inverter circuit and, if a preset threshold is exceeded, shuts down the +14.2 V inverter. If the overcurrent condition lasts for a preset length (approx. 50 msec), the surge current delay circuit generates a shutdown signal which is fed to the softstart circuitry to shutdown the main inverter.

---

## +5 V Inverter Circuitry

### **Overview**

The +5 V inverter circuitry operates identically to the +14.2 V inverter circuitry (described above) to generate a +5 V dc supply voltage. This voltage is used as the +5 V supply voltage for the station modules (via the backplane).



---

## Diagnostics Circuitry

**Note:** The cooling fan in the Power Supply Module is thermostatically controlled and may come on at any time during station operation. Failure of the fan to rotate continuously does not indicate a failure of the module.

### Overview

The diagnostics circuitry consists of an 11-channel A/D converter which converts analog status signals from critical points in the module to digital format for transfer to the Station Control Module via the SPI bus. Most of the status signals are generated by detect circuits to indicate the status of dc supply voltages and references.

### Temperature Monitor and Control Circuitry

A thermistor mounted on the power supply module heatsink provides a varying resistance input to several detect and control circuits, as follows:

- **Heatsink Status Detect** — compares signal from thermistor to reference voltage to generate an output proportional to heatsink temperature; signal is sent to Station Control Board via A/D converter and SPI bus.
- **Hi-Temp Detect** — compares signal from thermistor to reference voltage to generate a high temperature signal if preset threshold is exceeded; signal is sent to softstart circuitry to shut down main inverter if overtemperature condition is detected.
- **Fan Control Circuitry**— compares signal from thermistor to reference voltage to generate a fan control signal to turn on cooling fan mounted in power supply module; also generated is a FAN ON status signal which is sent to Station Control Board via A/D converter and SPI bus.

Note that a Fan Fault Detect circuit accepts a pulsed feedback signal from the cooling fan to indicate whether the fan is functioning (when turned on by Fan Control Circuitry); a FAN FAIL status signal is sent to Station Control Board via A/D converter and SPI bus

### Status LED Indicators

Two LEDs located on the power supply module front panel indicate module status as follows:

- **Power On**— lights GREEN when power supply module is turned on and functioning properly; LED turns off when module is turned off, input power is removed, or module startup circuitry is in fail mode
- **Module Fail**— lights RED when power supply module is in fail mode, or if a failure in another station module causes excessive current drain on any of the power supply output voltages; LED turns off when module is functioning properly

---

## Address Decode Circuitry

The address decode circuitry allows the Station Control Board to use the address bus to select the A/D converter (Diagnostics Circuitry) for communications via the SPI bus. Typical communications include reading status signals from the Diagnostics Circuitry.

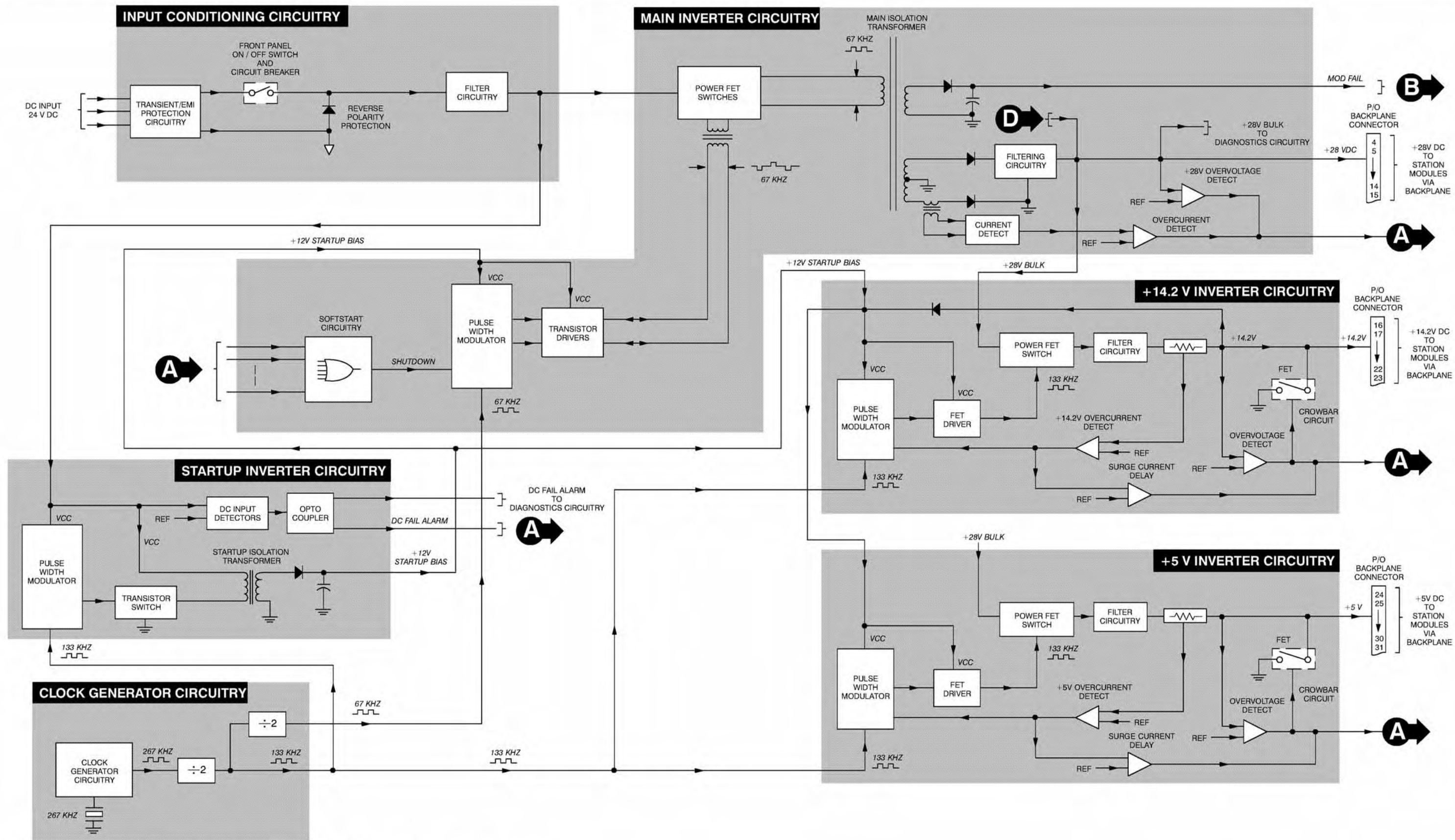

Figure 2. 600W DC/DC Power Supply Module Functional Block Diagram (Sheet 1 of 2)

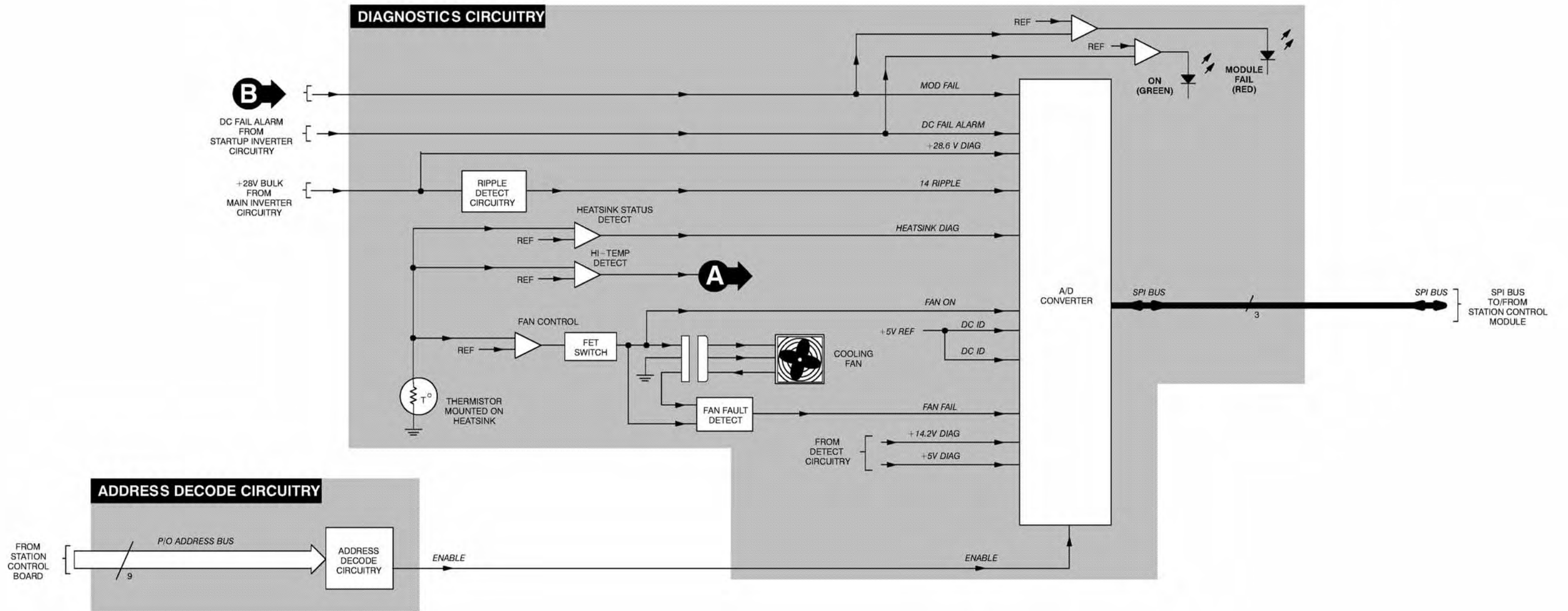

Figure 2. 600W DC/DC Power Supply Module Functional Block Diagram (Sheet 2 of 2)

# 1 DESCRIPTION

The Model CPN1031B Power Supply Module is described in this section. A general description, performance specifications, identification of controls, indicators, and inputs/outputs, a functional block diagram, and functional theory of operation are provided. The information provided is sufficient to give service personnel a functional understanding of the module, allowing maintenance and troubleshooting to the module level. (Refer also to the Maintenance and Troubleshooting section of this manual for detailed troubleshooting procedures for all modules in the station.)

## General Description

The Models CPN1031B Power Supply Module accepts a dc input of either 48 V dc or 60 V dc and generates +28.6V dc, +14.2V dc, and +5.1V dc operating voltages to power the station modules. The power supply module is comprised of two circuit boards which provide several switching-type power supply circuits and diagnostics and monitoring circuitry, all contained within a slide-in module housing.

The power supply module provides the following features:

- **Internal voltage and current limiting** — circuitry continually monitors critical voltages and currents and shuts supply down if preset thresholds are exceeded
- **Temperature protection** — module contains built-in cooling fan; supply shuts down if temperature exceeds preset threshold
- **Diagnostic monitoring** — critical internal parameters are continually monitored and reported to the Station Control Module, which can automatically provide correction for certain operating conditions
- **Fan Failure Protection** — Power Supply enters shutdown mode in event of cooling fan failure
- **Auto Recovery from Shutdown** — Power Supply automatically recovers from shutdown mode if the cause of the shutdown no longer exists
- **Limited In-Rush Current** — Circuitry limits in-rush current to less than 30 A in all conditions

## Power Supply Module Simplified Block Diagram

The illustration below provides a simplified block diagram of a Power Supply Module showing how the two circuit boards interconnect. A detailed block diagram and functional theory of operation for each board is provided later in this section (beginning on page 6).

### POWER SUPPLY MODULE

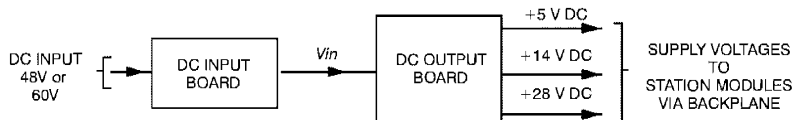

## Overview of Circuitry

The power supply module is comprised of two circuit boards, connected together via cables. These boards contain circuitry as follows:

### DC Input Board (CPN6064B)

- **Input Conditioning Circuitry** — consists of: dc filtering components, reverse polarity circuitry to protect power supply circuitry from reverse polarity connection to external DC source, Startup Delay Circuitry
  - Filter Circuitry to provide filtering of DC input voltage
  - Reverse Polarity Circuitry to protect power supply circuitry from reverse polarity connection to external DC source
  - Startup Delay Circuitry to provide a delay of approximately 1.5 seconds from time on/off switch is turned on until the power supply becomes functional (allows pre-charge of high-capacity filter capacitors to limit in-rush current on power up)
  - Filter Circuitry to provide filtering of DC output voltage
- **Inverter Circuitry A and B** — consists of two inverter circuits that accept gating signals from the *Inverters A/B Control Circuitry* (on DC Output Board) to provide 133 kHz signal to *Output Filter Circuitry* and to the *+5V and +14V Power Supply Circuits* (on DC Output Board)
- **Output Filter Circuitry** — consists of dc filtering components to filter the +28 V dc output voltage supplied to the station modules

### DC Output Board (CPN6068A)

- **Inverters A/B Control Circuitry** — consists of switching-type circuitry that generates the 133 kHz *V\_GATE\_1* and *V\_GATE\_2* signals to the *Inverter A* and *Inverter B* circuitry on the DC Input Board; also contains *Peak Current Limiting Circuitry* and *Over-voltage Protection Circuitry*.
- **+14 V Supply Circuitry** — consists of switching-type power supply that generates the +14 V dc supply voltage.
- **+5 V Supply Circuitry** — consists of switching-type power supply that generates the +5 V dc supply voltage.
- **Reference Voltage Circuitry** — Generates +10V\_SEC and +2.5V\_SEC supply voltages for use by local circuitry.
- **Diagnostics Circuitry** — converts analog status signals to digital format for transfer to Station Control Module.
- **Address Decode Circuitry** — performs address decoding to provide chip select signal for the A/D converter.
- **Startup/Shutdown Control Circuitry** — Provides delay interval for shutdown of entire power supply module.

## 2 PERFORMANCE SPECIFICATIONS

Table 1 shows the electrical performance specifications for the Model CPN1031B Power Supply Module.

### Performance Specifications

**Table 1.** CPN1031B Power Supply Module Performance Specifications

Parameter	Specification
Weight	6.5 kg (14.3 lbs)
Operating Temperature Range	-30 to +60° C (no derating)
Input Voltage Range	+43.2 V dc to +62.4 V dc
Maximum Input Current	22 A
Steady State Output Voltages	+28.6 V dc ±5% +14.2 V dc ±5% +5.0 V dc ±5%
Output Current Ratings	+28.6 12.5 A +14.2 8 A +5.1 3 A
Total Output Power Rating	No Derating 600 W
Output Ripple	All outputs 50 mV p-p (measured with 20 MHz BW oscilloscope at 25° C).  High Frequency individual harmonic voltage limits in 10 kHz-100 MHz frequency band:  28.6V 1.5 mV p-p 14.2 V 3.0 mV p-p 5V 5.0 mV p-p
Short Circuit Current	25.5 A ± 3 A

### 3 CONTROLS, INDICATORS, AND INPUTS/OUTPUTS

Figure 1 shows the power supply module controls, indicators, and all input and output external connections.

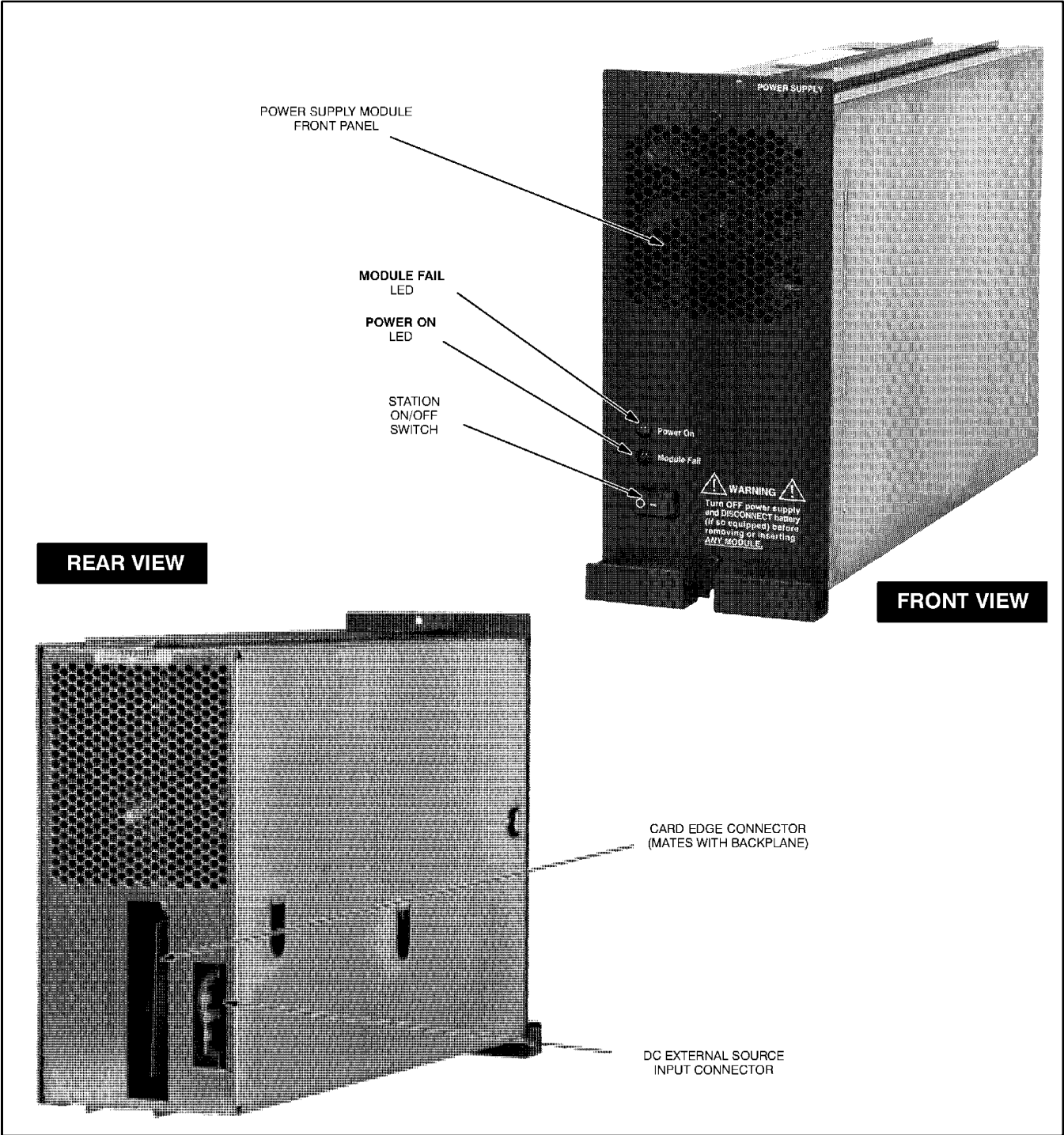

Figure 1. CPN1031B Power Supply Module Controls, Indicators, and Inputs/Outputs



## 4 FUNCTIONAL THEORY OF OPERATION (DC Input Board)

The following theory of operation describes the operation of the CPN6064B DC Input Board circuitry at a functional level. The information is presented to give the service technician a basic understanding of the functions performed by the module in order to facilitate maintenance and troubleshooting to the module level. Refer to Figure 2 for a block diagram of the DC Input Board.

### Input Conditioning Circuitry

#### *Introduction*

The DC Input Board accepts dc power from an external source, typically a bank of storage batteries. DC power is connected to the board via a 4-wire dc input cable mounted on the station backplane.

#### *Input Filter Circuitry*

The DC input voltage is fed to filtering circuitry. This circuitry consists of filter capacitors that remove any ripple and/or transients from the input dc signal.

#### *Front Panel On–Off Switch / Startup Delay Circuitry*

A rocker-type switch located on the power supply module front panel allows the power supply (and station) to be turned on and off. Note that the switch allows the output filter circuitry to slowly charge (for approximately 1.5 seconds after switch is turned on) through two diodes and resistors. After the 1.5 second delay, the relay turns on and provides the full dc input voltage to the output filter circuitry. This 1.5 second pre-charge delay period limits in-rush current through the filter capacitors upon power up.

If the DC input is below approximately 43.2 V, the relay will not be turned on and the power supply outputs will be disabled. The red **Module Fail** LED on the front panel will light.

#### *Output Filter Circuitry*

The DC input voltage is fed to filtering circuitry. This circuitry consists of filter capacitors that remove any ripple or noise from the switching circuitry from the +28 V dc output.

---

## Inverter Circuitry A and B

Inverter Circuitry A and Inverter Circuitry B are identical switching-type circuits that accept the gating signals (V\_GATE\_1 and V\_GATE\_2) from the DC Output Board and generate a 133 kHz output signal. This signal is fed to the Output Filter Circuitry (which provides a +28 V dc supply voltage to the station) and to the +5V and +14V Supply Circuits on the DC Output Board.

---

## Output Filter Circuitry

This circuitry consists of a series of filter capacitors that filter the 133 kHz signal from Inverter Circuits A and B to provide a +28 V dc supply voltage for use by the station modules (via the backplane).

## 5 FUNCTIONAL THEORY OF OPERATION (DC Output Board)

The following theory of operation describes the operation of the CPN6068A DC Output Board circuitry at a functional level. The information is presented to give the service technician a basic understanding of the functions performed by the module in order to facilitate maintenance and troubleshooting to the module level. Refer to Figure 3 for a block diagram of the DC Output Board.

### Inverters A/B Control Circuitry

#### **Overview**

The Inverters A/B Control Circuitry is comprised of two mirrored switching-type circuits which generate the V\_GATE\_1 and V\_GATE\_2 signals used by the Inverter Circuitry A and Inverter Circuitry B (located on the DC Input Board).

#### **Switching Circuitry Operation**

The switching circuitry consists of two identical switching-type circuits operating in parallel. Both circuits operate identically, as follows. A 67 kHz clock signal from the Sync Generator Circuitry is fed through a buffer to a Pulse Width Modulator (PWM). The PWM outputs a 133 kHz signal (V\_GATE\_1 or V\_GATE\_2) which is fed to Inverter Circuitry A (or Inverter Circuitry B) located on the DC Input Board.

Since Inverter Circuitry A and Inverter Circuitry B each receives a 133 kHz V\_GATE signal that is 180° out of phase with the other, each circuit alternately charges the output filter circuitry, resulting in an effective charging rate of 133 kHz.

#### **Protection Circuitry**

**Peak/Average Current Limiting Circuitry** — The peak current limiting circuitry accepts an output current feedback signal and a scaled +28V\_RAW reference signal to control the PWMs. This effectively maintains a constant output voltage for varying output current demands.

The average current limiting circuitry monitors the +28 V dc output and generates a shutdown signal (PRI\_SHUTDOWN) if the average output current reaches a predetermined limit.

**Overvoltage Protection Circuitry** — This circuitry monitors the +28V\_RAW voltage and generates a shutdown signal (PRI\_SHUT\_SEC) to shut down the entire power supply module if the +28 V output voltage exceeds a preset threshold.

---

## +14 V Supply Circuitry

### **Overview**

The +14 V Supply Circuitry is comprised of a switching-type power supply which generates a +14.2 V dc supply voltage. This voltage is used as the +14.2 V supply voltage for the station modules (via the backplane).

### **Switching Power Supply Operation**

The +14 V switching power supply consists of a pulse width modulator (PWM) running at 133 kHz. The PWM output pulses are fed through a driver to control a power FET which repetitively gates the +28V\_RAW (from the Output Filter Circuitry on the DC Input Board) to a power coil. The result is a high induced voltage which charges the filter capacitors to approximately +14.2 V dc. A current sense comparator provides a feedback signal to the PWM to maintain a constant output voltage.

### **Protection Circuitry**

An overvoltage detect circuit monitors the output voltage and, if preset thresholds are exceeded, turns on a FET crowbar circuit which immediately discharges the output to protect other modules in the station.

An overcurrent detect circuit monitors the current draw from the +14V Supply Circuitry and, if a preset threshold is exceeded, generates a PRI\_SHUT\_SEC signal which shuts down the entire power supply module.

---

## +5 V Supply Circuitry

The +5 V Supply Circuitry operates identically to the +14 V Supply Circuitry (described above) to generate a +5.1 V dc supply voltage. This voltage is used as the +5 V supply voltage for the station modules (via the backplane).

---

## Reference Voltage Circuitry

This circuitry accepts +28V\_RAW (from the +28V Main Supply Circuitry) and generates +10V\_SEC and +2.5V\_SEC supply voltages for use by local circuitry.

---

## Diagnostics Circuitry

### **Overview**

The diagnostics circuitry consists of an 11-channel A/D converter which converts analog status signals from critical points in the power supply module to digital format for transfer to the Station Control Module via the SPI bus. Most of the status signals are generated by detect circuits to indicate the status of dc supply voltages and references.

### **Temperature Monitor and Control Circuitry**

A thermistor mounted on the power supply module heatsink provides a varying resistance input to the Heatsink Temp Detect Circuitry. If the heatsink temperature exceeds a preset limit, the circuitry generates a PRI\_SHUT\_SEC shutdown signal which shuts down the entire power supply module. A HEATSINK\_DIAG signal is also sent to the Station Control Module via the A/D converter and SPI bus.

### **Overvoltage/Undervoltage Detect Circuitry**

This circuitry monitors the VIN\_FLTRD signal from the DC Input Board and generates a DC\_GOOD\_DIAG signal as long as the VIN\_FLTRD signal remains within predetermined limits. The circuitry also drives the LED indicators (described below).

### **LED Status Indicators**

Two LEDs located on the power supply module front panel indicate module status as follows:

- **Power On**— lights GREEN when On/Off switch is On and the AC input voltage is within operating range; LED turns off when module is turned off, ac power is removed, or AC input voltage is below approximately 85 V rms.
- **Module Fail**— lights RED when initially turning on or off the Power Supply (this is normal and does not indicate a failure) or when the DC-to-DC Converter Board is not functioning properly; LED turns off when module is functioning properly

---

## Address Decode Circuitry

The address decode circuitry allows the Station Control Module to use the address bus to select either the D/A converter (Battery Charger/Revert Board) or the A/D converter (Diagnostics Circuitry) for communications via the SPI bus. Typical communications include reading status signals from the Diagnostics Circuitry.

---

## Startup/Shutdown Control Circuitry

### ***Shutdown Delay Circuitry***

Upon receiving a shutdown signal (PRI\_SHUTDOWN) from the +28V Main Supply Circuitry, this circuit passes the signal through the Soft Start Circuitry for a 1 second interval to allow the entire power supply module to shutdown. The module then restarts (if the on/off switch is in **On** position). If the PRI\_SHUTDOWN signal is still active, the shutdown process will repeat.

### ***Soft Start Circuitry***

Each time the Soft Start Circuitry receives a startup signal (i.e., PRI\_SHUTDOWN is inactive), the Soft Start Circuitry provides a gradually increasing output signal to “soft start” the Pulse Width Modulators (p/o +28V Main Supply Circuitry). This action minimizes the surge current when charging the output filter capacitors.

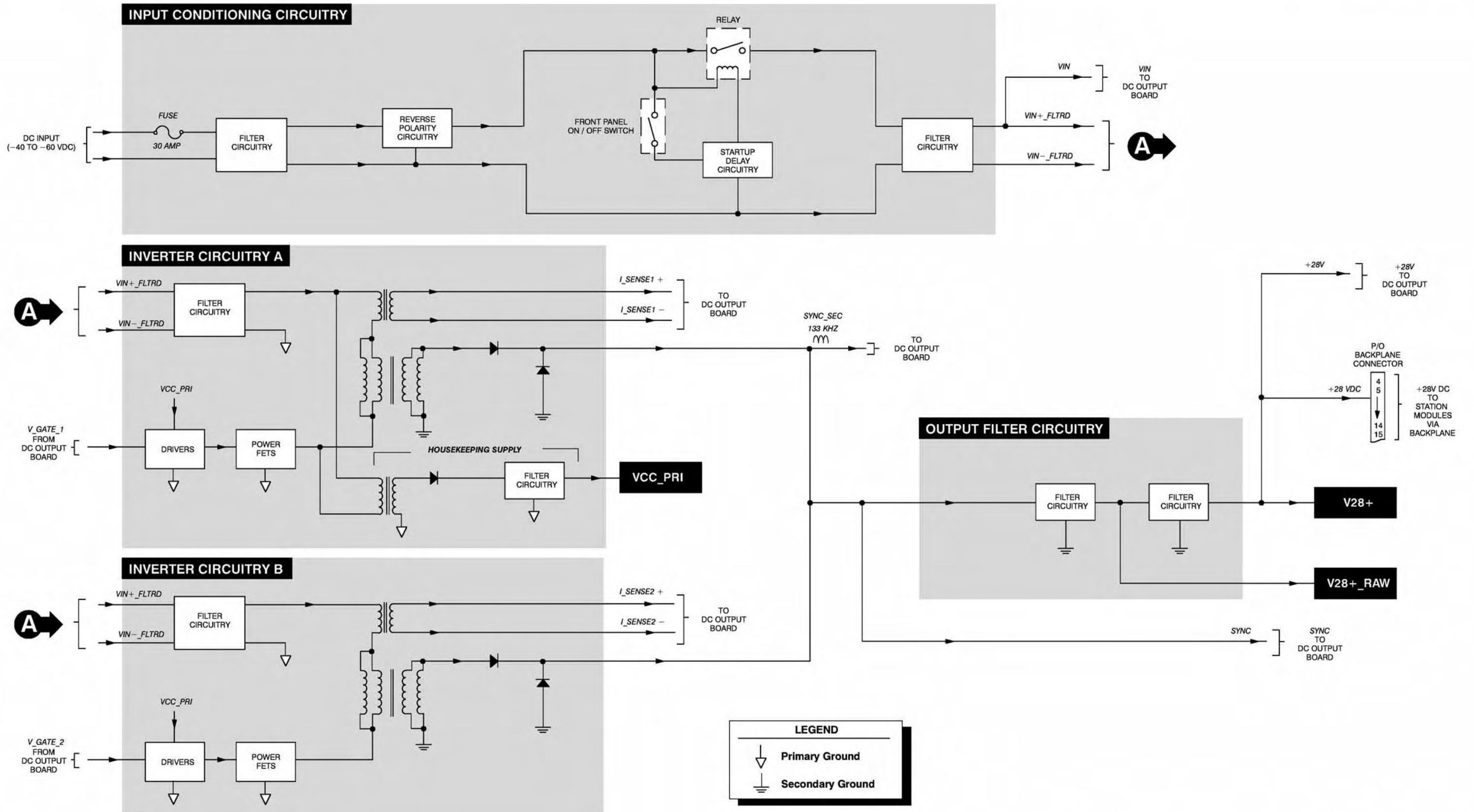

Figure 2. CPN6064B DC Input Board Functional Block Diagram

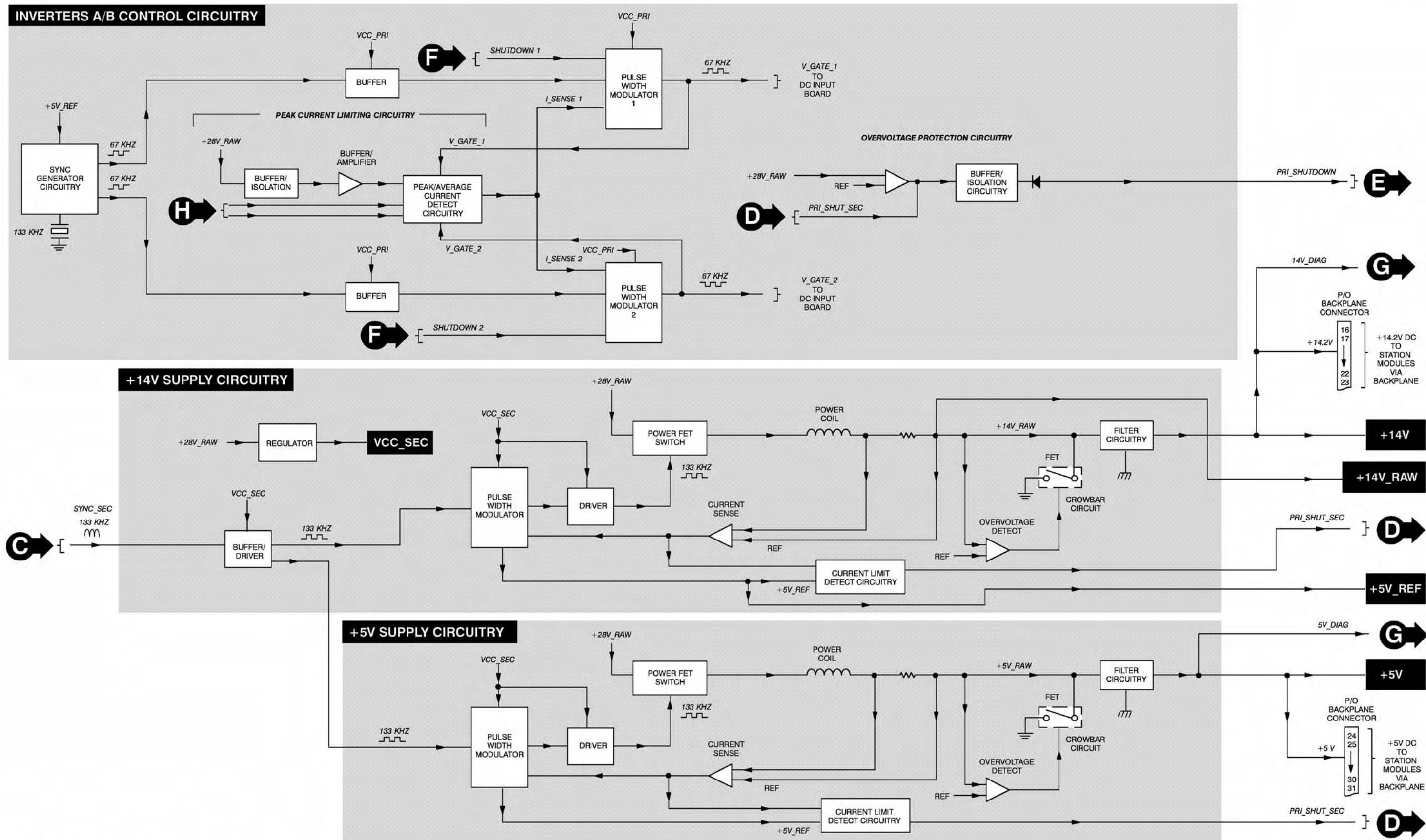

Figure 3. CPN6068A DC Output Board Functional Block Diagram (1 of 2)



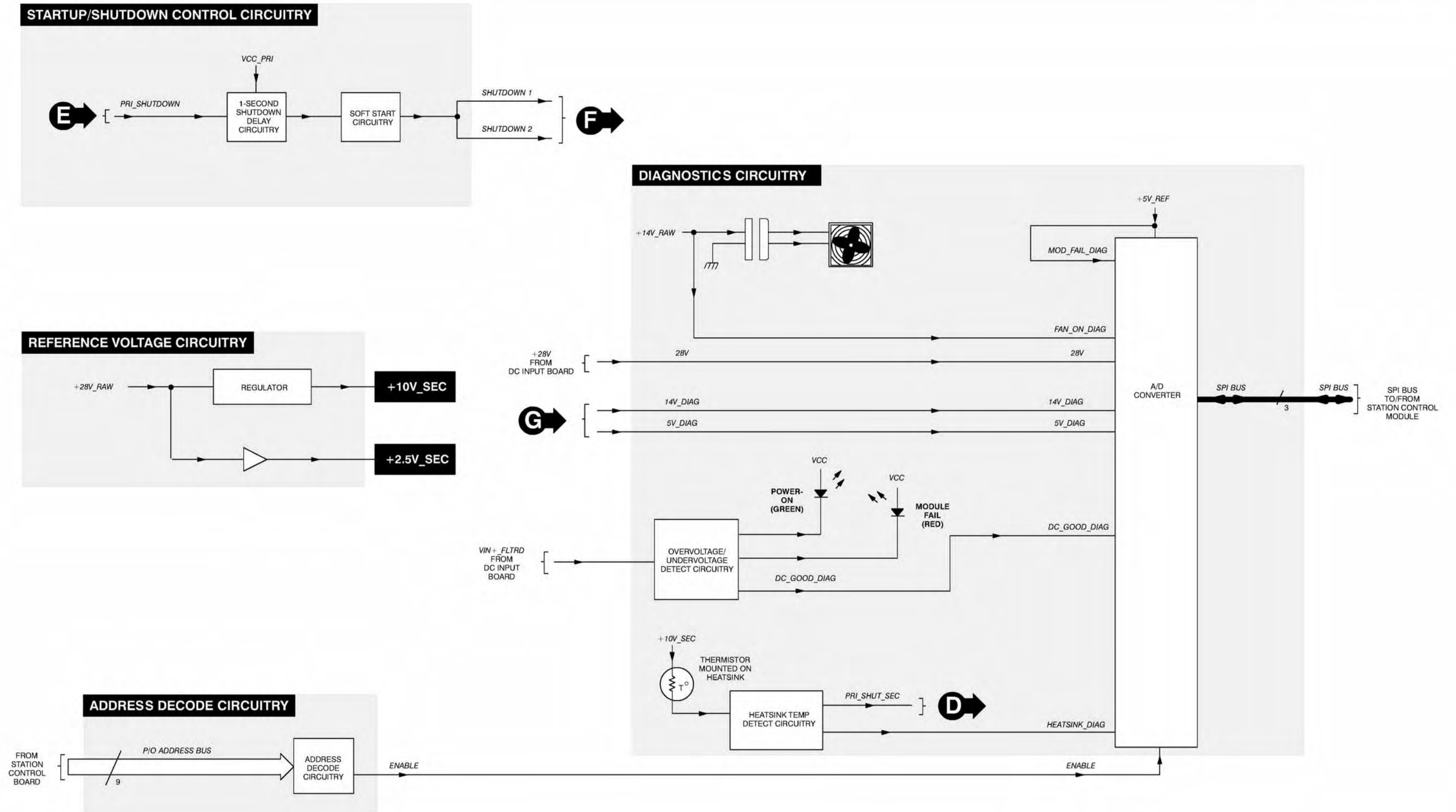

Figure 3. CPN6068A DC Output Board Functional Block Diagram (2 of 2)

END OF PART 10

## 1 DESCRIPTION

Option X371AA provides an antenna relay module for use with *Quantar* and *Quantro* station products. This section provides a general description, option complement, identification of inputs/outputs, and functional theory of operation. The information provided is sufficient to give service personnel a functional understanding of the module, allowing maintenance and troubleshooting to the module level. (Refer also to the Maintenance and Troubleshooting section of this manual for detailed troubleshooting procedures for all modules in the station.)

### General Description

This antenna relay module allows a single antenna to be used for both transmit and receive functions (base station applications only). The antenna relay is controlled by a signal from the Station Control Module to connect the antenna to either the Power Amplifier Module (transmit) or Receiver Module (receive). The antenna relay module is mounted on an angle bracket provided on the rear of the station card cage.

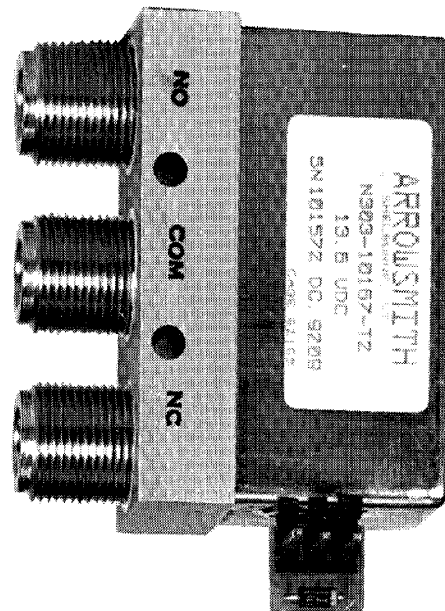

**Figure 1.** Typical Antenna Relay Module

## 2 INPUT AND OUTPUT CONNECTIONS

Figure 2 shows the antenna relay module input and output external connections.

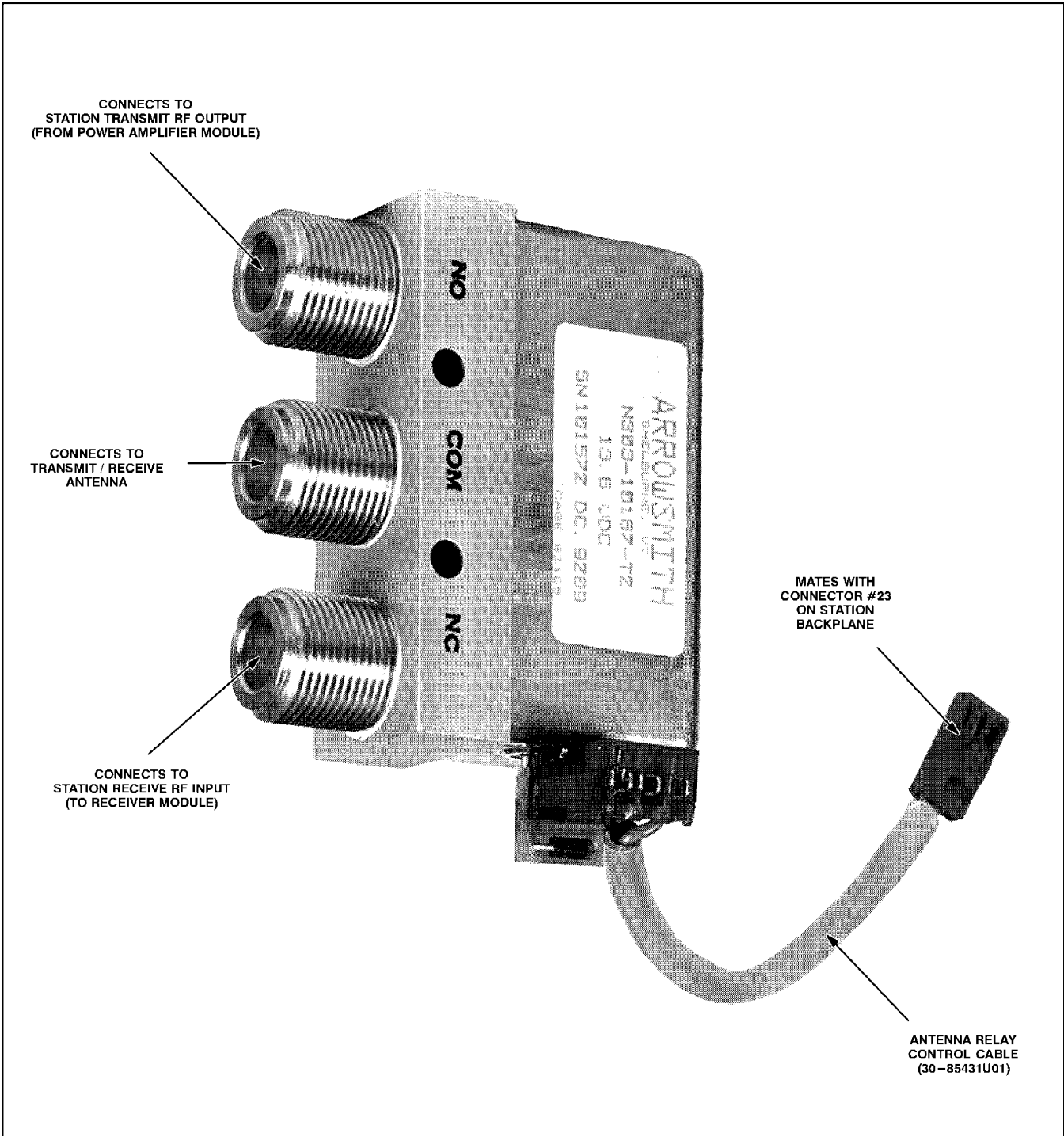

Figure 2. Antenna Relay Module Inputs/Outputs

### 3 OPTION COMPLEMENT

Table 1 shows the contents for the Option X371AA antenna relay module.

#### Option Complement Chart

**Table 1.** Antenna Relay Option X371AA Complement

Model	Description
TRN7664A	Includes miscellaneous hardware and antenna relay module (Motorola Part No. 80-84033T02)

### 4 PERFORMANCE SPECIFICATIONS

Table 2 shows the electrical performance specifications for the antenna relay used in Options X371AA-AC.

#### Performance Specifications

**Table 2.** Performance Specifications for Antenna Relay

Parameter	Specification
Operating Frequency	DC – 4 GHz
Maximum Input Power	500W
Coil Specifications: Pull-in voltage Drop-out voltage Resistance	9.5V dc 2V dc 100Ω ±10% @ 20°C
Contacts Specifications: Type Actuation Pull-in time Drop-out time	SPDT Failsafe 20 msec max. 10 msec max.
Insertion Loss	0.30dB max
Isolation	70dB min
VSWR Maximum	1.3 : 1
Temperature Range	-30°C to +80°C
Terminations	Female N-Type
Input and Output Impedance	50 Ohms

# 5 MOUNTING LOCATIONS

In order to provide alternative routing for the antenna rf cable, the Antenna Relay Module may be installed in two positions on the rf input/output bracket. Stations equipped with the antenna relay module option are shipped with the antenna relay module installed as shown in Figure 3, allowing the rf cable to be routed out the side of the cabinet or rack. If desired, the bracket may be turned 90° counterclockwise to allow the cable to be routed toward the bottom of the cabinet or rack, as shown in Figure 4.

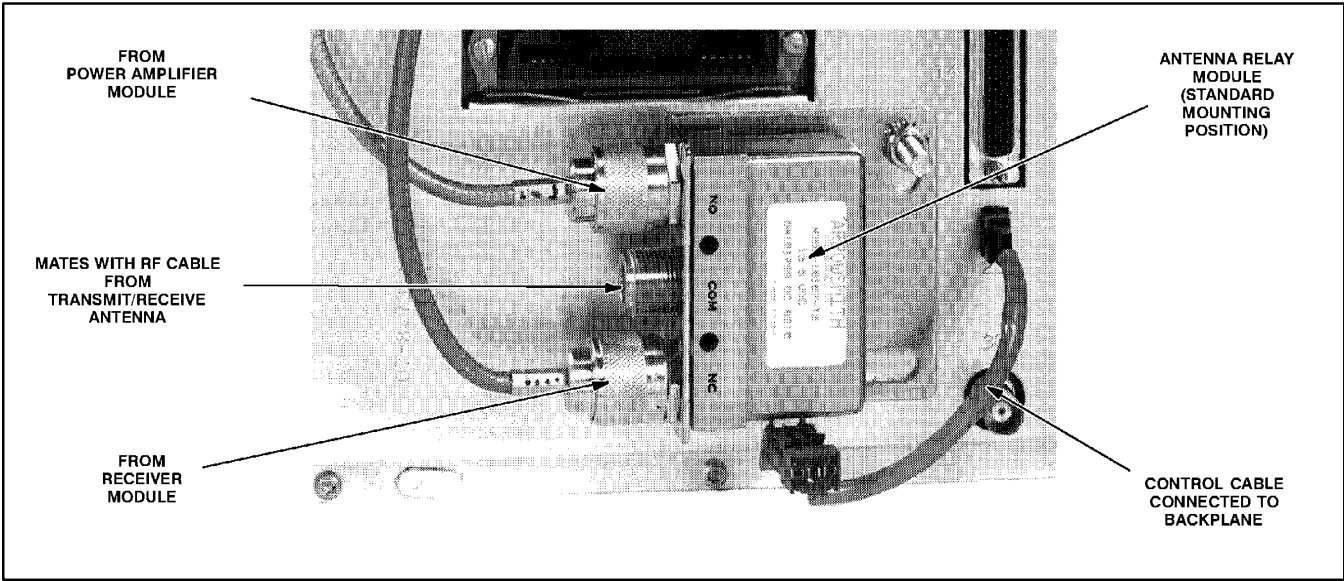

**Figure 3.** Standard Mounting Position for Antenna Relay Module

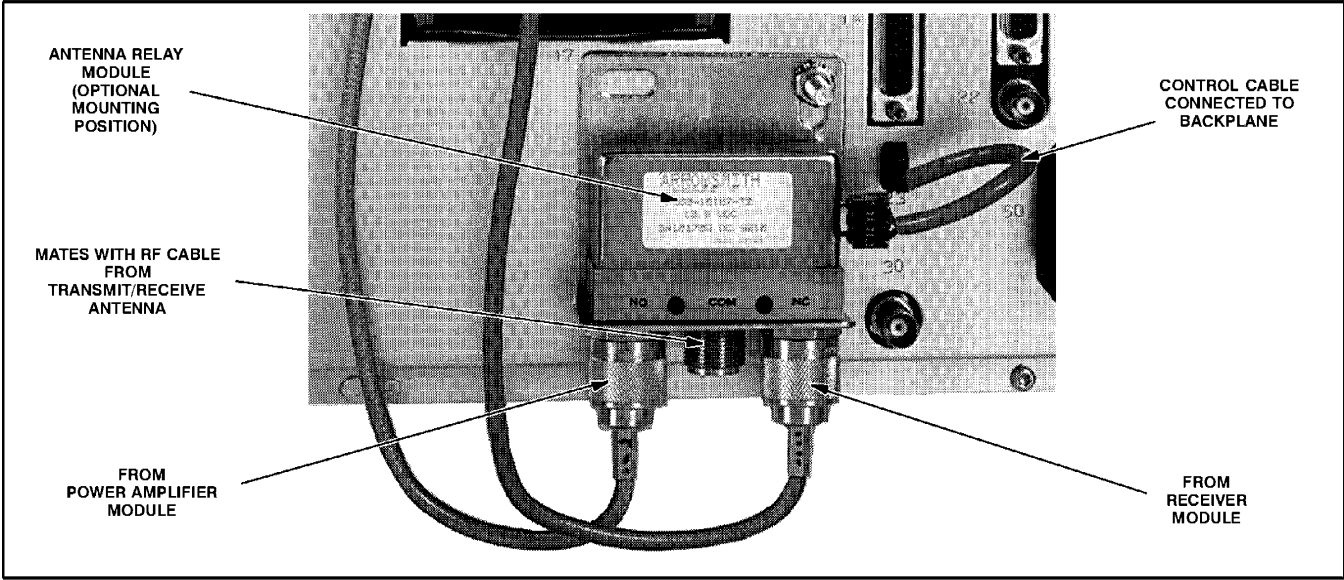

**Figure 4.** Optional Mounting Position for Antenna Relay Module

## 6 FUNCTIONAL THEORY OF OPERATION

The following theory of operation describes the operation of the Antenna Relay Module at a functional level. The information is presented to give the service technician a basic understanding of the functions performed by the module in order to facilitate maintenance and troubleshooting to the module level. Refer to Figure 5 for a block and interconnect diagram of the Antenna Relay Module.

### Functional Operation

*Note that with the relay de-energized the antenna is connected to the Receiver Module. To connect the antenna to the Power Amplifier Module, the Station Control Module must energize the relay.*

The Antenna Relay Module contains a relay with a set of normally open and normally closed contacts. The relay coil is controlled by a signal from the Station Control Module to connect either the Receiver Module or the Power Amplifier Module to a single transmit/receive antenna. Refer to the block diagram shown in Figure 5.

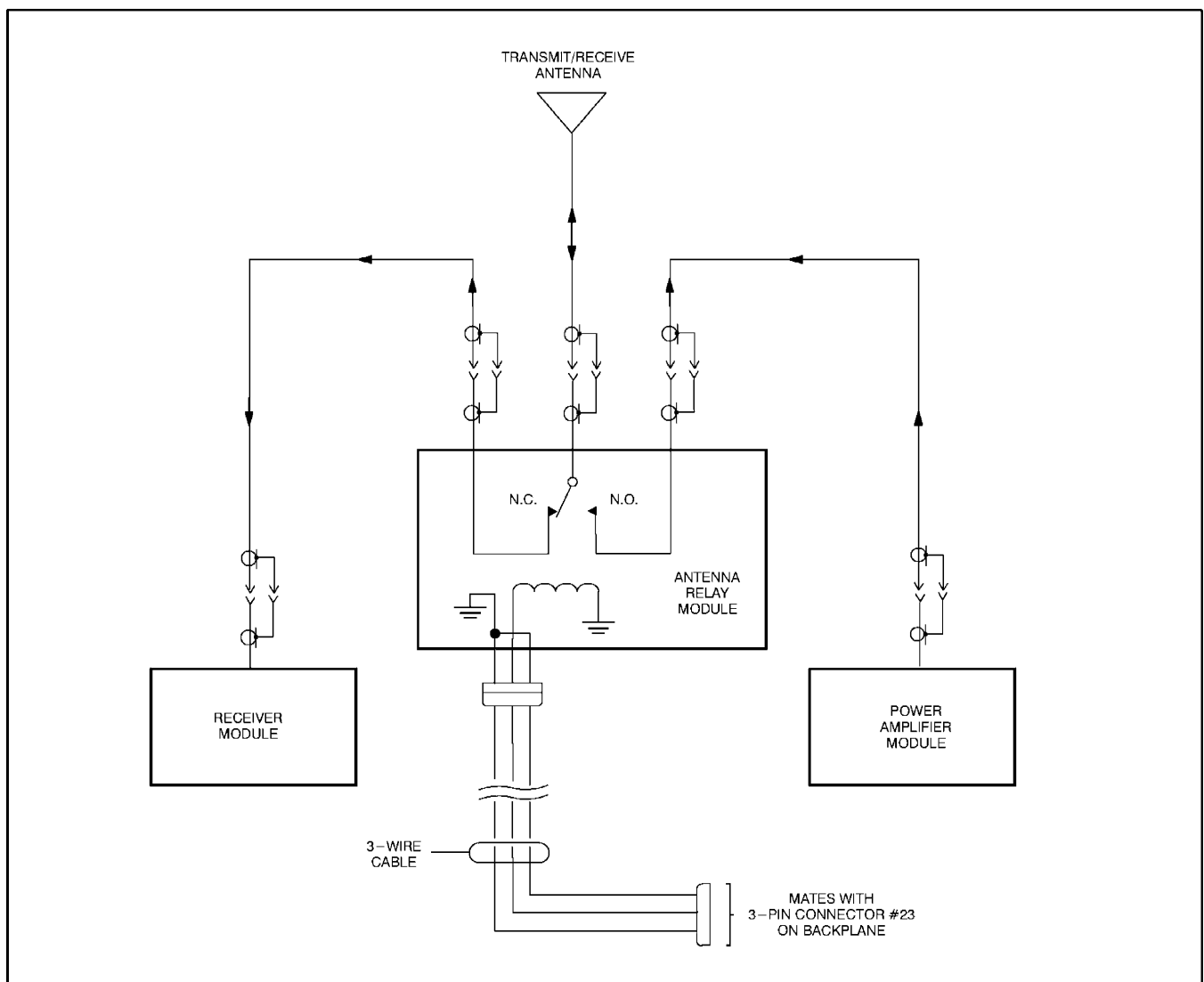

**Figure 5.** Functional Block and Interconnect Diagram for Antenna Relay Module

---

---

## 1 DESCRIPTION

Options X676AA–AC provide band–specific dual circulator assemblies and low pass filters for use with *Quantar* VHF station. The triple circulator option is comprised of the dual circulator assembly combined with the single circulator located in the station power amplifier module. This combination provides 65 dB (min) of isolation between the Power Amplifier Module and the transmit antenna. A low pass filter connects between the dual circulator output and the transmit antenna.

This section provides a general description, option matrix chart, identification of inputs/outputs, and functional theory of operation. The information provided is sufficient to give service personnel a functional understanding of the module, allowing maintenance and troubleshooting to the module level. (Refer also to the Maintenance and Troubleshooting section of this manual for detailed troubleshooting procedures for all modules in the station.)

---

### General Description

The dual circulator assembly consists of two rf circulators and a 50  $\Omega$  load with heat sink, all mounted on a 3/16 " aluminum plate which is housed in the Peripheral Tray. The tray is equipped with a cooling fan which directs air across the fins of the heat sink. The rf output from the Power Amplifier Module connects to the input of the assembly, while the output connects to an external low pass filter. The output of the filter connects to the transmit antenna (directly, via antenna relay module, or via duplexer).

---

## 2 OPTIONS COMPLEMENT

Table 1 shows the applications and contents for the available triple circulator options for *Quantar* VHF station.

---

### Option Complement Chart

**Table 1.** Triple Circulator Options Complement

Option	Application	Option Contents
X676AA	<i>Quantar</i> VHF High Band (132–146 MHz)	TYD4001A TLN3391A TYD4010A TRN7796A Dual Circulator 50Ω Load w/ heatsink Low Pass Filter Cooling Fan
X676AB	<i>Quantar</i> VHF High Band (144–160 MHz)	TYD4002A TLN3391A TYD4010A TRN7796A Dual Circulator 50Ω Load w/ heatsink Low Pass Filter Cooling Fan
X676AC	<i>Quantar</i> VHF High Band (158–174 MHz)	TYD4003A TLN3391A TYD4010A TRN7796A Dual Circulator 50Ω Load w/ heatsink Low Pass Filter Cooling Fan



### 3 PERFORMANCE SPECIFICATIONS

Table 2 shows the electrical performance specifications for the dual circulator assembly used for Options X676AA–AC.

Table 3 shows the electrical performance specifications for the low pass filter used in Options X676AA–AC.

#### Performance Specifications

**Table 2.** Performance Specifications for Dual Circulator Assembly

Parameter	Specification
Operating Frequency X676AA X676AB X676AC	132–146 MHz 144–160 MHz 158–174 MHz
Maximum RF Input Power	400W
Insertion Loss	1.25dB max (with low pass filter)
Isolation	45 dB min <i>(total of 65 dB when combined with circulator built into power amplifier module)</i>
Operating Temperature Range	–20°C to +70°C
Input/Output Return Loss	19.1 dB min
Terminations	Female N–Type
Input and Output Impedance	50 Ohms
50Ω Load Maximum Power	25W without cooling fan on 90W with cooling fan on
Thermistor Output	50 kΩ @ 25°C 1.7 k Ω @ 125°C

**Table 3.** Performance Specifications for Low Pass Filter

Parameter	Specification
Operating Frequency	132–174 MHz
Insertion Loss	0.25 dB
Maximum RF Input Power	350W
Rejection	55 dB min (264–600 MHz)

## 4 INPUTS/OUTPUTS

Figure 1 shows the dual circulator assembly input and output external connections.

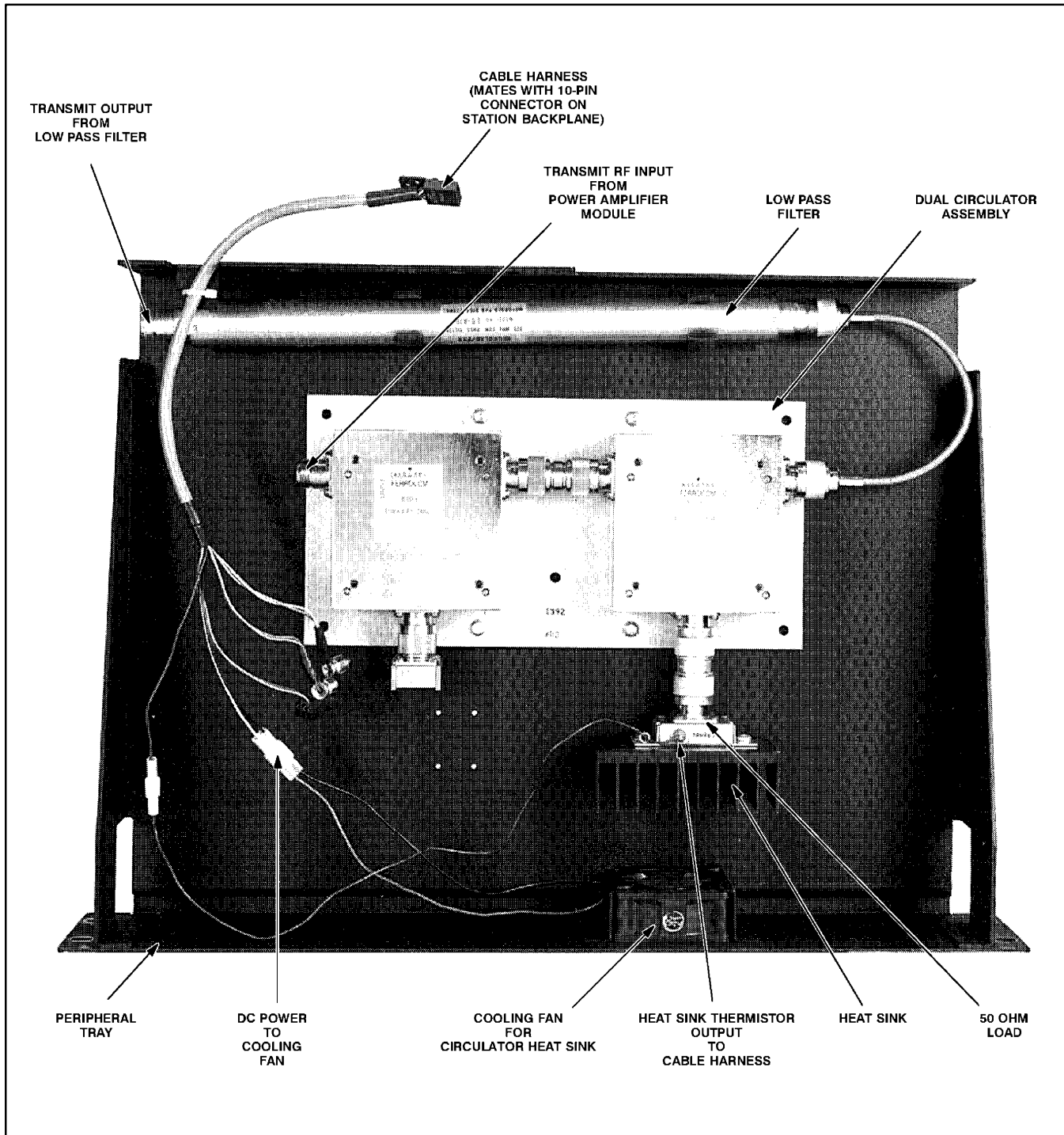

**Figure 1.** Dual Circulator Assembly and Low Pass Filter (Mounted in Peripheral Tray) Inputs and Outputs

## 5 FUNCTIONAL THEORY OF OPERATION

The following theory of operation describes the operation of the Dual Circulator Assembly and Low Pass Filter at a functional level. The information is presented to give the service technician a basic understanding of the functions performed by the module in order to facilitate maintenance and troubleshooting to the module level. Refer to Figure 5 for a block and interconnect diagram of the Dual Circulator Assembly and Low Pass Filter.

### Functional Operation

**Note:** The Triple Circulator Option is typically used in high density radio site applications where other co-located transmitters near the frequency of the station can cause I.M. products. The addition of the dual circulator improves I.M. from  $>30\text{dB}_i$  to  $>75\text{dB}_i$ . The low pass filter reduces spurious emissions to  $90\text{dBc}$ .

The Dual Circulator Assembly accepts transmit rf output power from the power amplifier module and provides 45 dB (minimum) of isolation between the power amplifier module and the transmit antenna. The assembly consists of two circulators, each with a  $50\Omega$  load. Each circulator allows forward rf energy to pass through to the output, while routing any reflected rf energy to the corresponding  $50\Omega$  load. Refer to the block diagram shown in Figure 5.

Most of the reflected energy is absorbed by the  $50\Omega$  load (heat sink mounted) connected to the second circulator. A thermistor mounted on the heat sink provides a variable resistance signal proportional to the heat sink temperature. This signal is routed to the Station Control Module via the Peripheral Tray cabling harness. If the heat sink temperature exceeds a preset threshold, the Station Control Module enables PA cutback mode. If the overtemperature condition persists, the power amplifier is shut down completely.

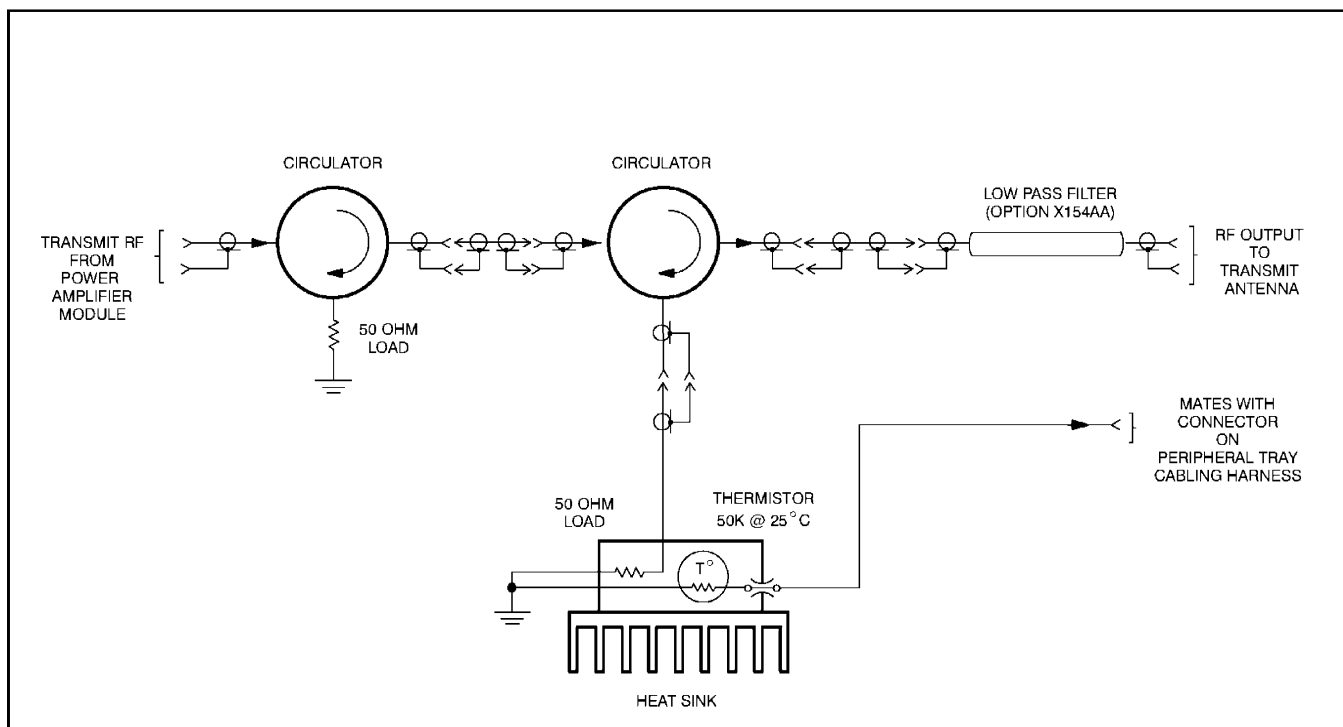

**Figure 2.** Functional Block and Interconnect Diagram for Dual Circulator Assembly

---

---

## 1 DESCRIPTION

Options CA00187AA, X676AN, and X676AP provide a dual circulator assembly and low pass filter for use with the *Quantar* UHF station. The triple circulator option is comprised of the dual circulator assembly combined with the single circulator located in the station power amplifier module. This combination provides 65 dB (min) of isolation between the Power Amplifier Module and the transmit antenna. A low pass filter connects between the dual circulator output and the transmit antenna.

This section provides a general description, option matrix chart, identification of inputs/outputs, and functional theory of operation. The information provided is sufficient to give service personnel a functional understanding of the module, allowing maintenance and troubleshooting to the module level. (Refer also to the Maintenance and Troubleshooting section of this manual for detailed troubleshooting procedures for all modules in the station.)

---

### General Description

The dual circulator assembly consists of a double rf circulator and a 50  $\Omega$  load with heat sink, all mounted on a 3/16 " aluminum plate which is housed in the Peripheral Tray. The tray is equipped with a cooling fan which directs air across the fins of the heat sink. The rf output from the Power Amplifier Module connects to the input of the assembly, while the output connects to an external low pass filter. The output of the filter connects to the transmit antenna (directly, via antenna relay module, or via duplexer).

## 2 OPTION COMPLEMENT

Table 1 through Table 3 show the contents of the CA00187AA, X676AN, and X676AP Triple Circulator Options.

### Option Complement Charts

**Table 1.** CA00187AA Triple Circulator Option Complement

Option	Option Contents
CA00187AA	CFX1076A Dual Circulator TLN3391A 50Ω Load w/ heatsink TRN7796A Cooling Fan TLE9140A Low Pass Filter

**Table 2.** X676AN Triple Circulator Option Complement

Option	Option Contents
X676AN	TLE9120A Dual Circulator TLN3391A 50Ω Load w/ heatsink TRN7796A Cooling Fan TLE9140A Low Pass Filter

**Table 3.** X676AP Triple Circulator Option Complement

Option	Option Contents
X676AP	TLE9130A Dual Circulator TLN3391A 50Ω Load w/ heatsink TRN7796A Cooling Fan TLE9140A Low Pass Filter

### 3 PERFORMANCE SPECIFICATIONS

Table 2 shows the electrical performance specifications for the dual circulator assemblies used in Options CA00187AA (UHF R0), X676AN (UHF R1/R2), and X676AP (UHF R3/R4). Table 3 shows the electrical performance specifications for the low pass filter used in Options CA00187AA, X676AN, and X676AP.

#### Performance Specifications

**Table 4.** Performance Specifications for Dual Circulator Assemblies

Parameter	Specification
Operating Frequency	CA00187AA 380–433 MHz X676AN 403–475 MHz X676AP 475–520 MHz
Maximum RF Input Power	400W
Insertion Loss (with low pass filter and cables)	1.15dB typ 1.6dB max
Isolation	45 dB min <i>(total of 60 dB when combined with circulator built into power amplifier module)</i>
Operating Temperature Range	–20°C to +70°C
Input/Output Return Loss	19.1 dB min
Terminations	Female N–Type
Input and Output Impedance	50 Ohms
50Ω Load Maximum Power	25W without cooling fan on 90W with cooling fan on
Thermistor Output	22 kΩ @ 25°C 1.7 kΩ @ 125°C

**Table 5.** Performance Specifications for Low Pass Filter

Parameter	Specification
Operating Frequency	380–520 MHz
Insertion Loss	0.2 dB
Maximum RF Input Power	500W

# 4 INPUTS/OUTPUTS

Figure 1 shows the dual circulator assembly input and output external connections.

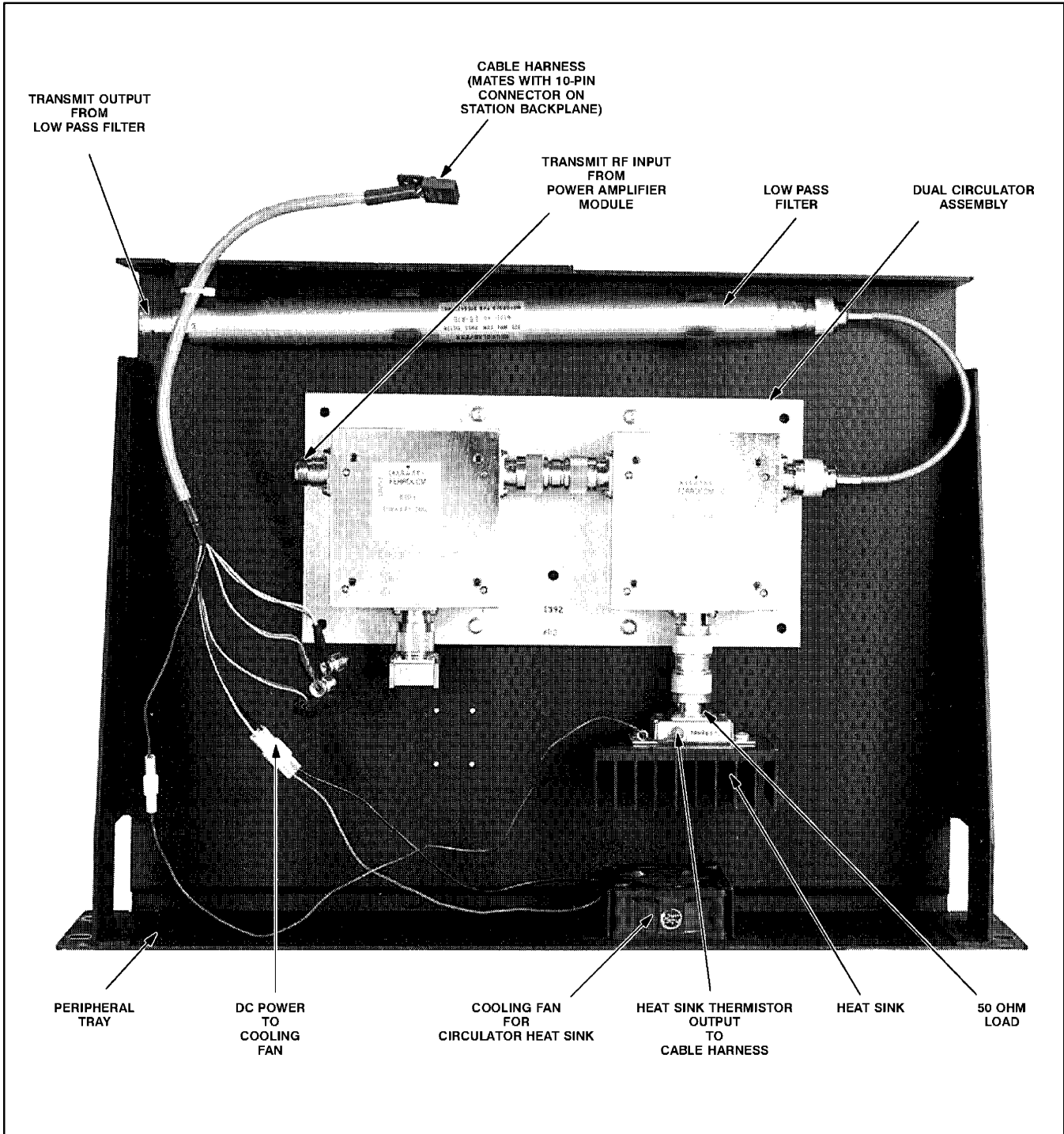

Figure 1. Dual Circulator Assembly and Low Pass Filter (Mounted in Peripheral Tray) Inputs and Outputs

## 5 FUNCTIONAL THEORY OF OPERATION

The following theory of operation describes the operation of the Dual Circulator Assembly and Low Pass Filter at a functional level. The information is presented to give the service technician a basic understanding of the functions performed by the module in order to facilitate maintenance and troubleshooting to the module level. Refer to Figure 5 for a block and interconnect diagram of the Dual Circulator Assembly and Low Pass Filter.

### Functional Operation

**Note:** The Triple Circulator Option is typically used in high density radio site applications where other co-located transmitters near the frequency of the station can cause I.M. products. The addition of the dual circulator improves I.M. from  $>20\text{dB}_i$  to  $>50\text{dB}_i$ . The low pass filter reduces spurious emissions to  $90\text{dBc}$ .

The Dual Circulator Assembly accepts transmit rf output power from the power amplifier module and provides 45 dB (minimum) of isolation between the power amplifier module and the transmit antenna. The assembly consists of two circulators, each with a  $50\Omega$  load. Each circulator allows forward rf energy to pass through to the output, while routing any reflected rf energy to the corresponding  $50\Omega$  load. Refer to the block diagram shown in Figure 5.

Most of the reflected energy is absorbed by the  $50\Omega$  load (heat sink mounted) connected to the second circulator. A thermistor mounted on the heat sink provides a variable resistance signal proportional to the heat sink temperature. This signal is routed to the Station Control Module via the Peripheral Tray cabling harness. If the heat sink temperature exceeds a preset threshold, the Station Control Module enables PA cutback mode. If the overtemperature condition persists, the power amplifier is shut down completely.

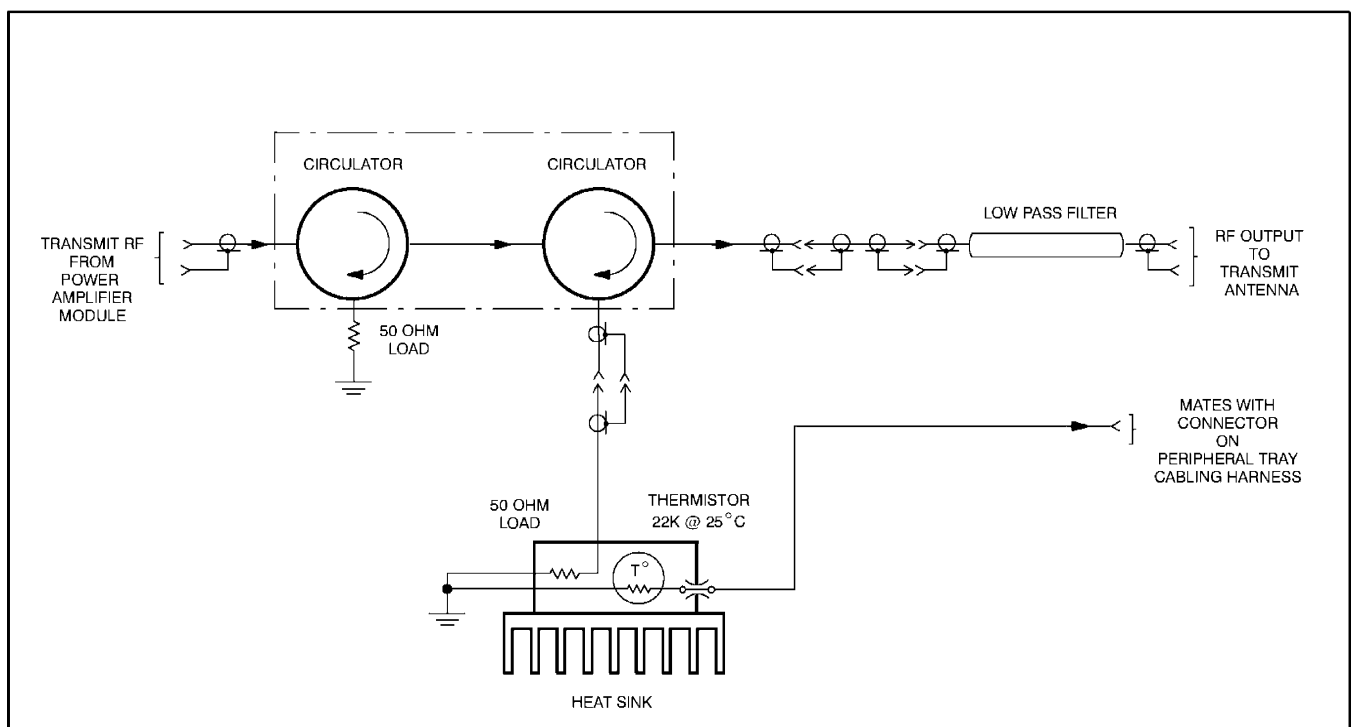

**Figure 2.** Functional Block and Interconnect Diagram for Triple Circulator Option



---

---

## 1 DESCRIPTION

Options X676AQ and X676AR provide a dual circulator assembly and low pass filter for use with the *Quantar* 800 MHz and 900 MHz stations, respectively. The triple circulator option is comprised of the dual circulator assembly combined with the single circulator located in the station power amplifier module. This combination provides 65 dB (min) of isolation between the Power Amplifier Module and the transmit antenna. A low pass filter connects between the dual circulator output and the transmit antenna.

This section provides a general description, option matrix chart, identification of inputs/outputs, and functional theory of operation. The information provided is sufficient to give service personnel a functional understanding of the module, allowing maintenance and troubleshooting to the module level. (Refer also to the Maintenance and Troubleshooting section of this manual for detailed troubleshooting procedures for all modules in the station.)

---

### General Description

The dual circulator assembly consists of a double rf circulator and a 50  $\Omega$  load with heat sink, all mounted on a 3/16 " aluminum plate which is housed in the Peripheral Tray. The tray is equipped with a cooling fan which directs air across the fins of the heat sink. The rf output from the Power Amplifier Module connects to the input of the assembly, while the output connects to an external low pass filter. The output of the filter connects to the transmit antenna (directly, via antenna relay module, or via duplexer).

## 2 OPTION COMPLEMENT

Table 1 and Table 3 show the contents of the X676AQ and X676AR Triple Circulator Options.

### Option Complement Charts

**Table 1.** X676AQ Triple Circulator Option Complement

Option	Option Contents
X676AQ	TLF7320A Dual Circulator TLN3391A 50Ω Load w/ heatsink TRN7796A Cooling Fan TLF7340A Low Pass Filter

**Table 2.** X676AR Triple Circulator Option Complement

Option	Option Contents
X676AR	TLF7330A Dual Circulator TLN3391A 50Ω Load w/ heatsink TRN7796A Cooling Fan TLF7340A Low Pass Filter

### 3 PERFORMANCE SPECIFICATIONS

Table 2 shows the electrical performance specifications for the dual circulator assemblies used in Options X676AQ (800 MHz) and X676AR (900 MHz). Table 3 shows the electrical performance specifications for the low pass filter used in Options X676AQ and X676AR.

#### Performance Specifications

**Table 3.** Performance Specifications for 800 MHz and 900 MHz Dual Circulator Assemblies

Parameter	Specification
Operating Frequency	X676AQ 850–870 MHz X676AR 935–941 MHz
Maximum RF Input Power	400W
Insertion Loss (with low pass filter and cables)	1.15dB typ 1.6dB max
Isolation	45 dB min <i>(total of 60 dB when combined with circulator built into power amplifier module)</i>
Operating Temperature Range	–20°C to +70°C
Input/Output Return Loss	19.1 dB min
Terminations	Female N–Type
Input and Output Impedance	50 Ohms
50Ω Load Maximum Power	25W without cooling fan on 90W with cooling fan on
Thermistor Output	22 kΩ @ 25°C 1.7 kΩ @ 125°C

**Table 4.** Performance Specifications for Low Pass Filter

Parameter	Specification
Operating Frequency	840–960 MHz
Insertion Loss	0.2 dB
Maximum RF Input Power	500W

# 4 INPUTS/OUTPUTS

Figure 1 shows the dual circulator assembly input and output external connections.

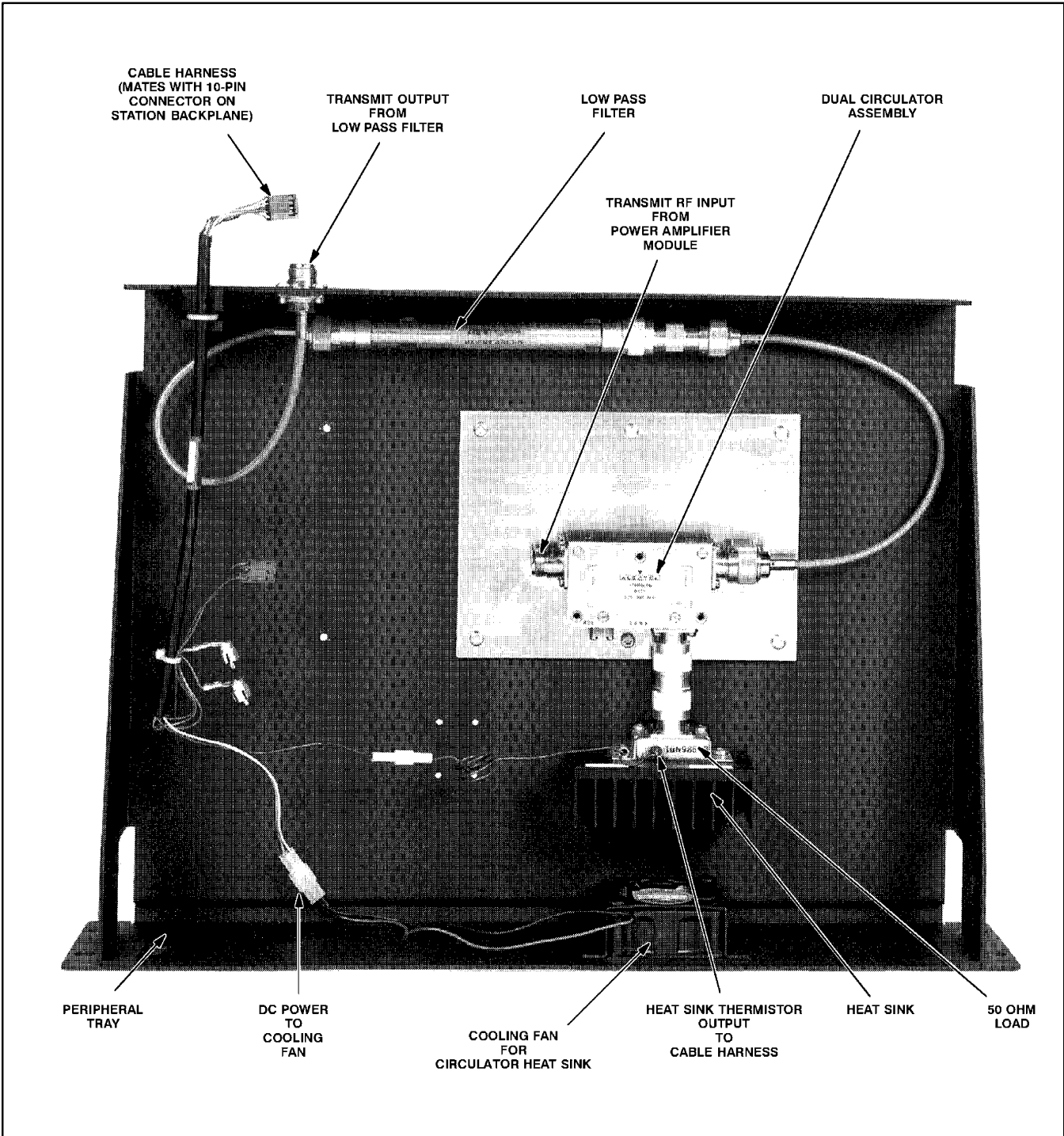

**Figure 1.** Dual Circulator Assembly and Low Pass Filter (Mounted in Peripheral Tray) Inputs and Outputs

## 5 FUNCTIONAL THEORY OF OPERATION

The following theory of operation describes the operation of the Dual Circulator Assembly and Low Pass Filter at a functional level. The information is presented to give the service technician a basic understanding of the functions performed by the module in order to facilitate maintenance and troubleshooting to the module level. Refer to Figure 5 for a block and interconnect diagram of the Dual Circulator Assembly and Low Pass Filter.

### Functional Operation

**Note:** The Triple Circulator Option is typically used in high density radio site applications where other co-located transmitters near the frequency of the station can cause I.M. products. The addition of the dual circulator improves I.M. from  $>20\text{dB}_i$  to  $>50\text{dB}_i$ . The low pass filter reduces spurious emissions to  $90\text{dBc}$ .

The Dual Circulator Assembly accepts transmit rf output power from the power amplifier module and provides 45 dB (minimum) of isolation between the power amplifier module and the transmit antenna. The assembly consists of two circulators, each with a  $50\Omega$  load. Each circulator allows forward rf energy to pass through to the output, while routing any reflected rf energy to the corresponding  $50\Omega$  load. Refer to the block diagram shown in Figure 5.

Most of the reflected energy is absorbed by the  $50\Omega$  load (heat sink mounted) connected to the second circulator. A thermistor mounted on the heat sink provides a variable resistance signal proportional to the heat sink temperature. This signal is routed to the Station Control Module via the Peripheral Tray cabling harness. If the heat sink temperature exceeds a preset threshold, the Station Control Module enables PA cutback mode. If the overtemperature condition persists, the power amplifier is shut down completely.

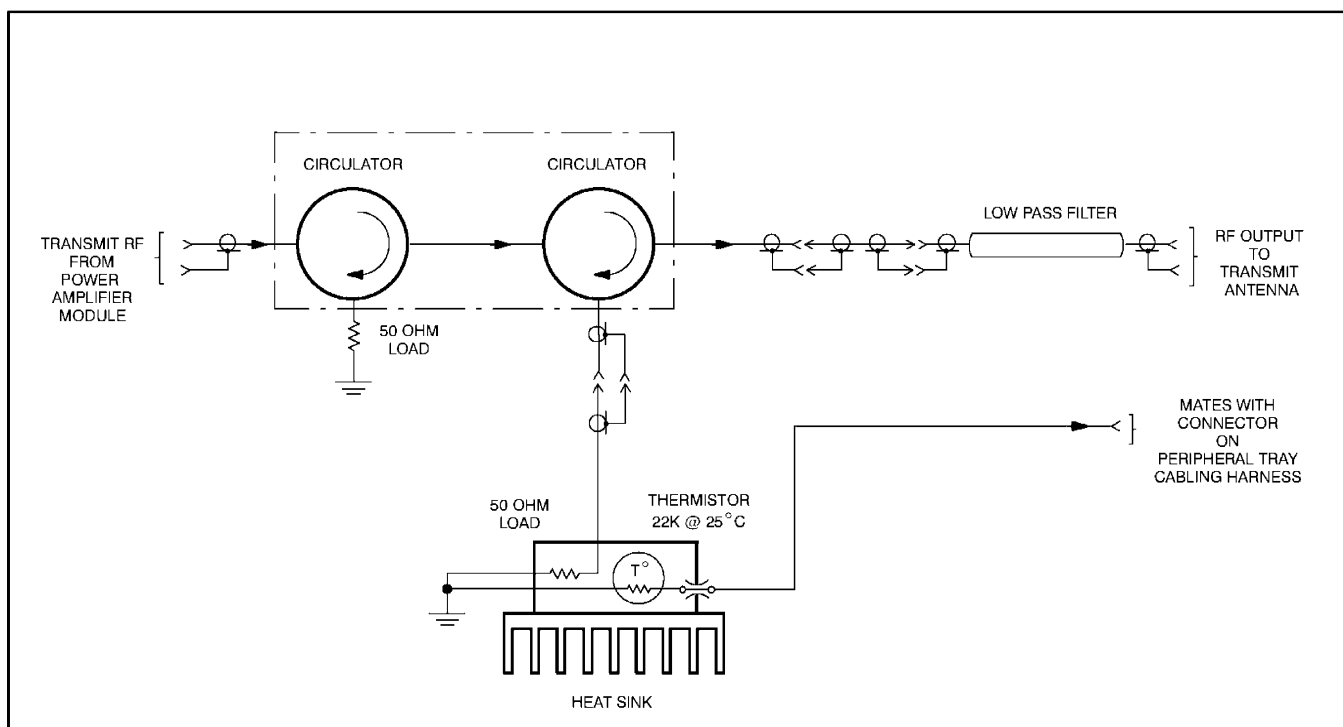

**Figure 2.** Functional Block and Interconnect Diagram for Triple Circulator Option

# DUPLEXER MODULE

Options X182AA (132–146 MHz)  
X182AB (144–160 MHz)  
X182AJ (158–174 MHz)

## 1 DESCRIPTION

Options 182AA/AB/AJ provide band–dependent duplexer modules for use with *Quantar* VHF stations. This section provides a general description, identification of adjustments and inputs/outputs, performance specifications, and a typical mounting location detail. While the duplexer module is considered non–repairable, tuning screws are provided for field tuning should replacement become necessary due to module failure, or if retuning is necessary due to a change in operating channels. A single channel field tuning procedure is provided in this section.

### General Description

The duplexer module (shown in Figure 1) allows a transmit and receive channel pair to share a common TX/RX antenna. Each duplexer module consists of six resonant cavities (three for transmit and three for receive) contained in a temperature–compensated copper enclosure designed to mount in a standard EIA 19” equipment rack.

Each set of three cavities is designed and tuned to pass the respective transmit or receive channel frequency (or bandwidths) while providing maximum TX noise suppression at the RX frequency and maximum RX isolation at the TX frequency.

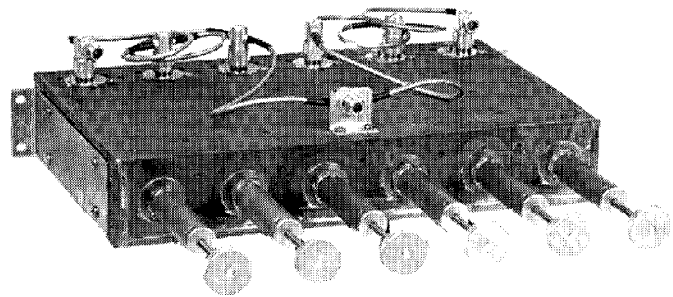

**Figure 1.** Typical Duplexer Module

## 2 ADJUSTMENTS AND INPUTS/OUTPUTS

Figure 2 shows the location of the adjustment screws and input and output rf connectors for the duplexer module.

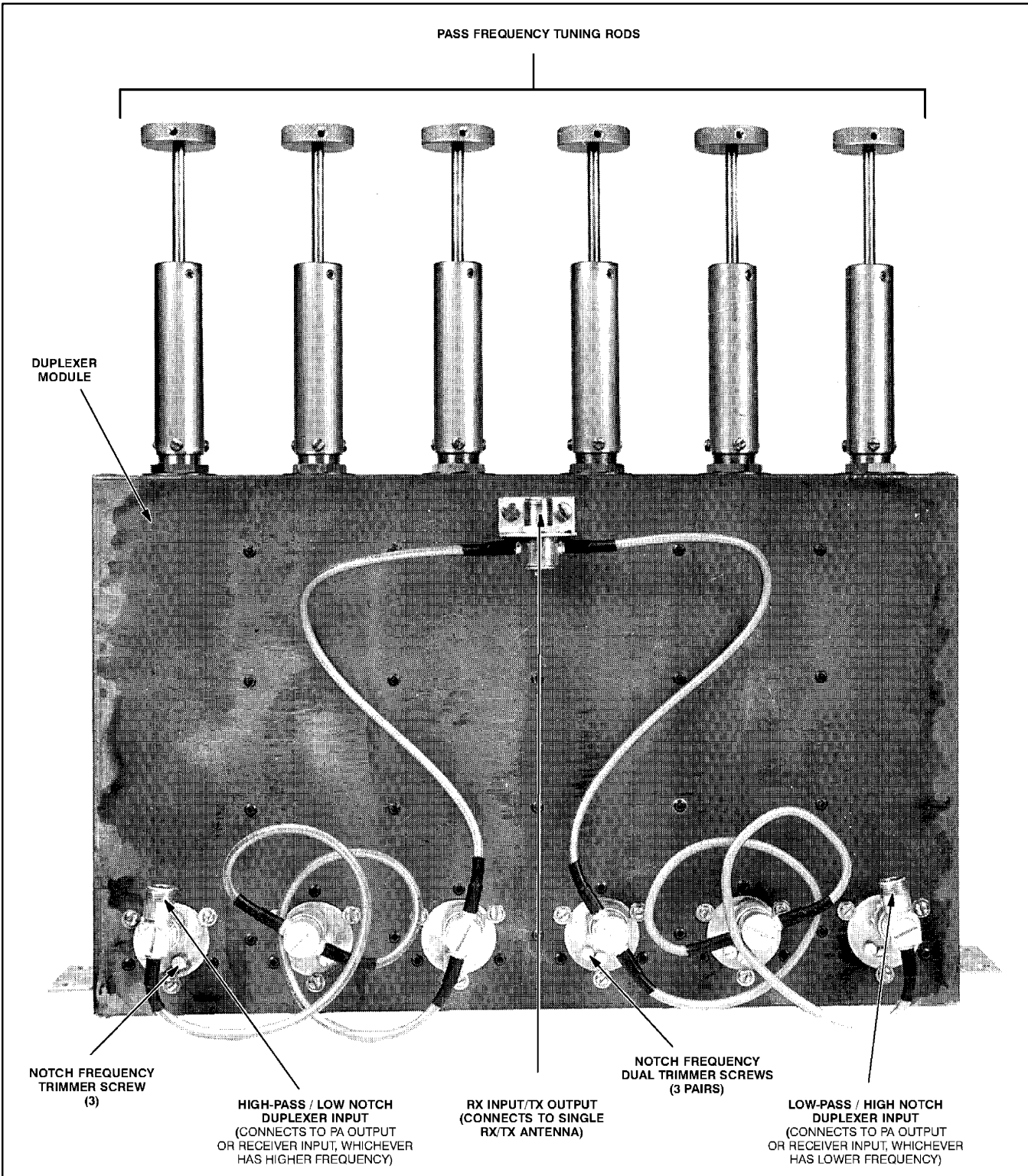

Figure 2. Quantar VHF Duplexer Module Adjustment Screws and Input/Output Connections

### 3 PERFORMANCE SPECIFICATIONS

Table 1 shows the electrical performance specifications for the duplexer module.

#### Performance Specifications

**Table 1.** Duplexer Performance Specifications (Options X182AA/AB/AJ)

Parameter	Specification	
Operating Frequency Model X182AA Model X182AB Model X182AJ	132–146 MHz 144–160 MHz 158–174 MHz	
Insertion Loss (Transmitter to Antenna)	1.3 dB max	
Insertion Loss (Antenna to Receiver)	1.3 dB max	
Frequency Bandwidth vs Frequency Separation	<b>Tx-to-RX Spacing</b>	<b>Bandwidth (maximum)</b>
	1.5 MHz	200 kHz
	2.5 MHz	600 kHz
	3.5 MHz	800 kHz
4.5 MHz and above	1000 kHz	
TX Noise Suppression at RX Freq.	75 dB min	
RX Isolation at TX Freq.	75 dB min	
Frequency Separation (Min.)	1.5 MHz	
Return Loss	14 dB minimum	
Maximum Input Power	150 W	
Temperature Range	–30°C to +60°C	
Size	3" (H) x 21.5" (D) x 17" (W) EIA Rack Mountable	
Weight	22 lbs.	
Terminations	Female N-Type	
Input and Output Impedance	50 Ohms	

*SPECIFICATIONS SUBJECT TO CHANGE WITHOUT NOTICE*



## **4** TYPICAL MOUNTING CONFIGURATION

The duplexer module is typically mounted in the same rack or cabinet as the station and peripheral tray (if equipped). Figure 3 shows front and rear views of a typical repeater configuration in which a station, triple circulator option, and duplexer option are installed in a single cabinet. Also shown is a simplified interconnect diagram showing the receiver and transmitter paths to a single RX/TX antenna.

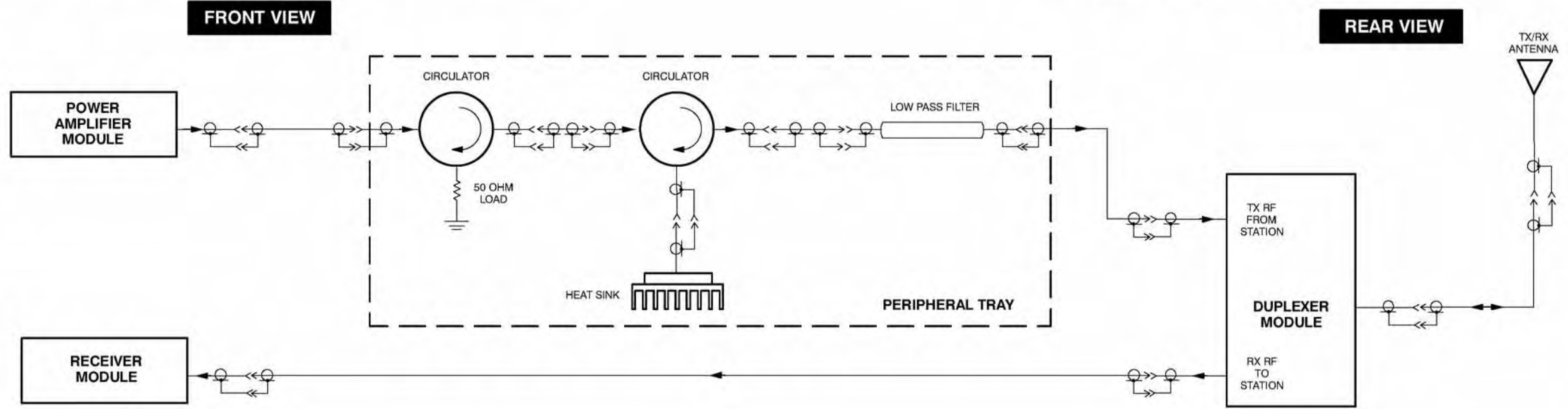
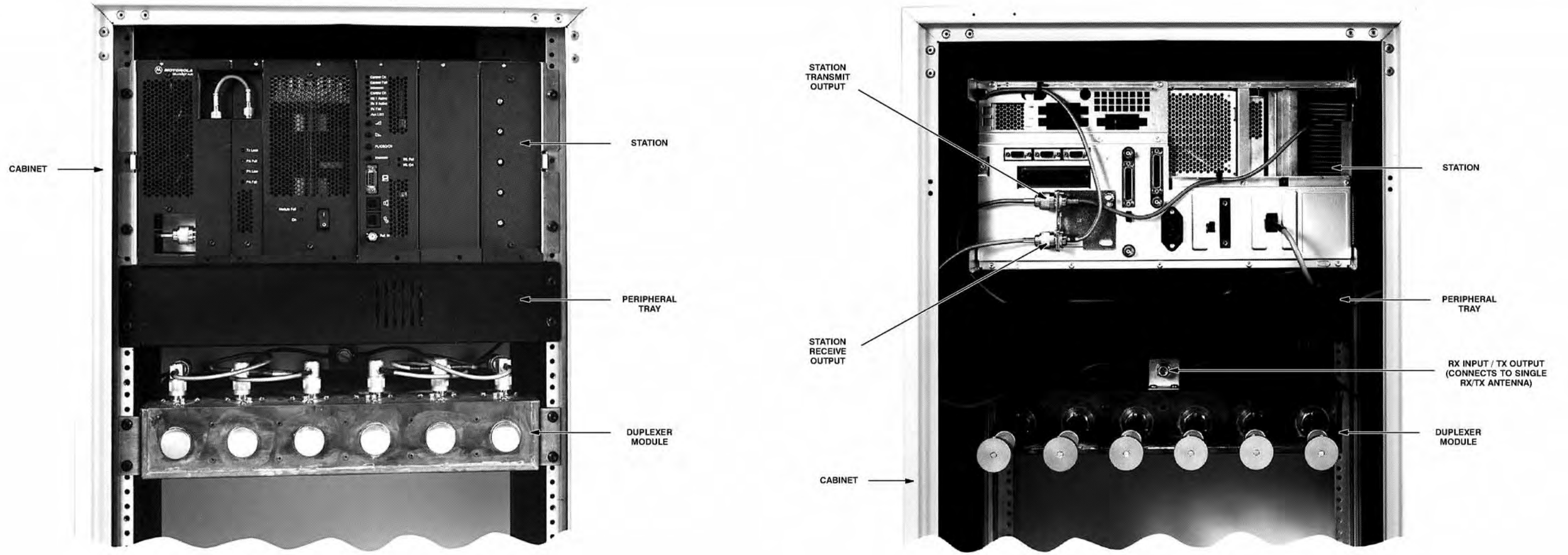

Figure 3. Typical Duplexer Mounting Configuration and Interconnect Diagram

## 5 FIELD TUNING PROCEDURE

Duplexer modules shipped with stations are tuned at the factory. If a duplexer must be replaced in the field, the unit must be installed and tuned specifically to the transmit and receive frequency pair for the particular station.

### Field Tuning Overview

**Note:** This tuning procedure is valid for channels with a bandwidth of 200 kHz or less. If bandwidth is more than 200 kHz, the duplexer must be tuned by the service depot.

The duplexer module is comprised of three low-pass/high-notch cavities and three high-pass/low-notch cavities. Each set of three cavities provides bandpass filtering for either the transmit rf signal or the receive rf signal. In general, the duplexer must be tuned so that the transmit cavity set passes the transmit signal and rejects the receive signal; concurrently, the receive cavity set must be tuned to pass the receive signal and reject the transmit signal.

Tuning is performed by injecting rf signals and making tuning adjustments (using the tuning rods and trimmer screws) while monitoring for maximum or minimum readings on the rf millivoltmeter. Field tuning the duplexer module requires the following general adjustments:

- Tune high-pass/low-notch cavities for maximum pass and reject response
- Tune low-pass/high-notch cavities for maximum pass and reject response
- Check high-pass/low-notch and low-pass/high-notch cavities for insertion loss
- Check high-pass/low-notch and low-pass/high-notch cavities for isolation

### Required Test Equipment

Field tuning of the duplexer module requires the following test equipment:

- Motorola R2001 Communications Analyzer (or equivalent)
- RF Millivoltmeter (Boonton 92E or equivalent)
- RF Signal Generator (HP8565 or equivalent)
- 50Ω N-type terminator
- Male-to-Females N-Type "T" connector (UG-107B/U or equiv.)
- Slotted screwdriver
- 3/32" allen wrench
- Tuning tool (thin blade)
- N-to-N bullet connector (UG29A/U or equivalent)
- N-to-BNC Adapter (UG349A/U)
- N-to-N Connector (UG57B/U)

## Setting Up for Tuning Duplexer

Perform the preliminary tasks shown in Figure 4 to prepare for tuning the duplexer module.

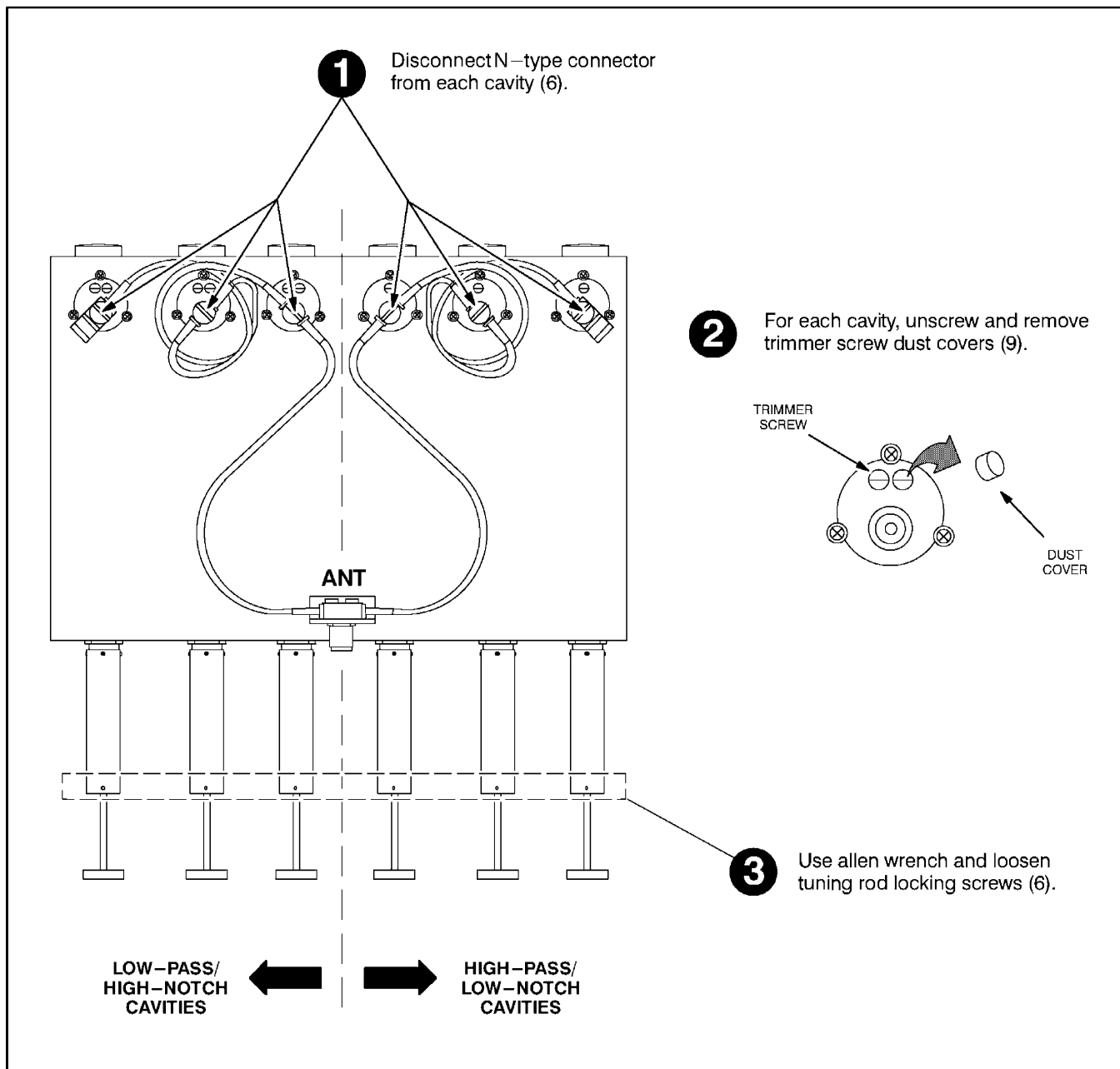

**Figure 4.** Preliminary Tasks Prior to Tuning Duplexer

---

## Duplexer Tuning Procedure

The duplexer field tuning procedures are provided in Figure 5. The procedures are most easily performed with the duplexer module removed from the station rack or cabinet. Be sure to make note of the transmit and receive frequencies for the particular station before beginning.

If the duplexer module is tuned according to instructions and does not meet specifications for return loss, insertion loss, and/or isolation, you must return the duplexer for repair.

# 1 TUNING LOW PASS RESONATORS

- 1 Set up test equipment as shown.
- 2 Push or pull tuning rod for cavity #1 to obtain a **PEAK** reading on the millivoltmeter
- 3 Use allen wrench and tighten locking screw.
- 4 Repeat steps 2 & 3 for cavities 2 and 3.

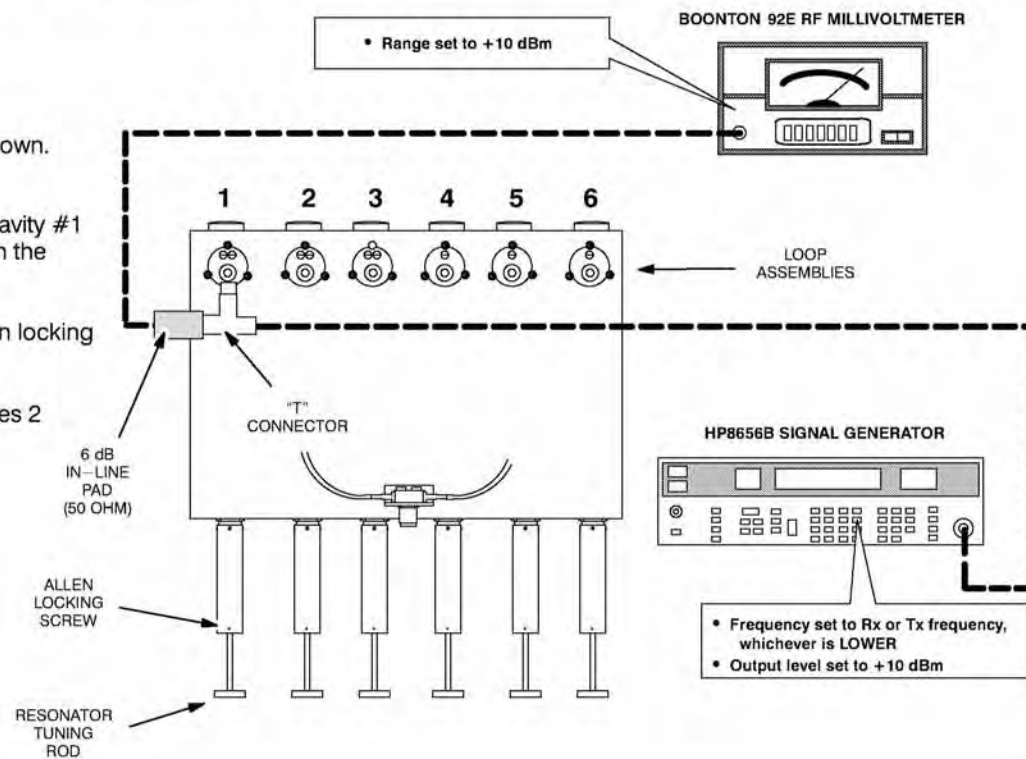

# 3 TUNING HIGH NOTCH LOOP ASSEMBLIES

- 1 Set up test equipment as shown.
- 2 Use tuning tool to adjust trimmer screws for cavity #1 to obtain **minimum** reading on millivoltmeter. (Adjust trimmer screws equally to obtain minimum. Reduce the range on the millivoltmeter as necessary to reach true minimum reading.)
- 3 Repeat steps 1 and 2 for cavities 2 and 3.

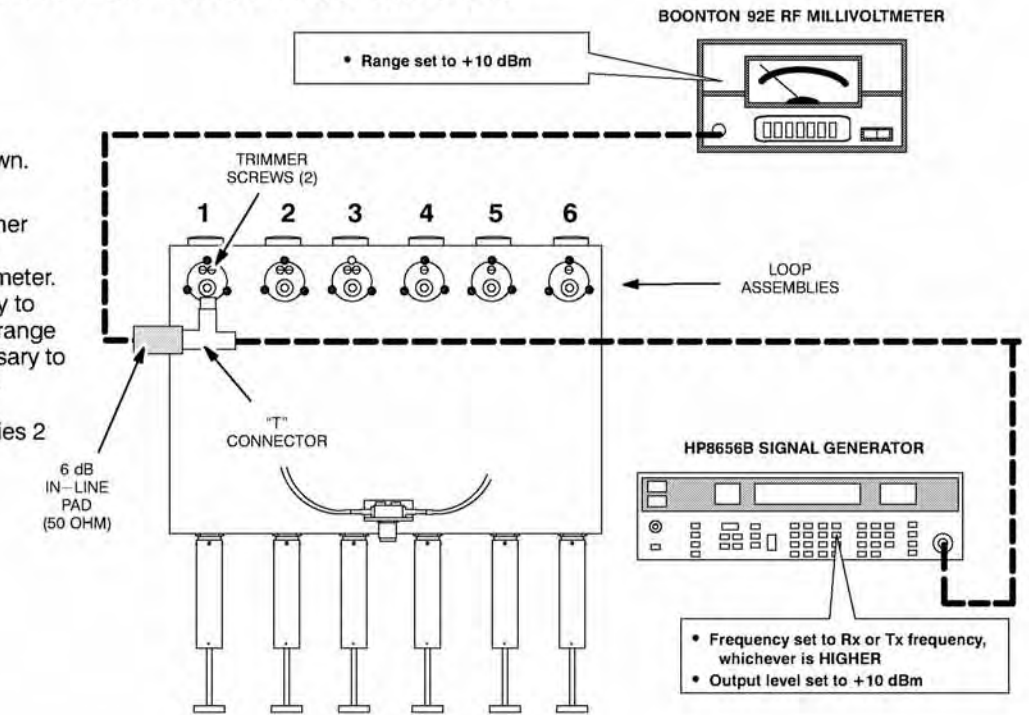

# 2 TUNING HIGH PASS RESONATORS

- 1 Set up test equipment as shown.
- 2 Push or pull tuning rod for cavity #4 to obtain a **PEAK** reading on the millivoltmeter
- 3 Use allen wrench and tighten locking screw.
- 4 Repeat steps 2 & 3 for cavities 5 and 6.

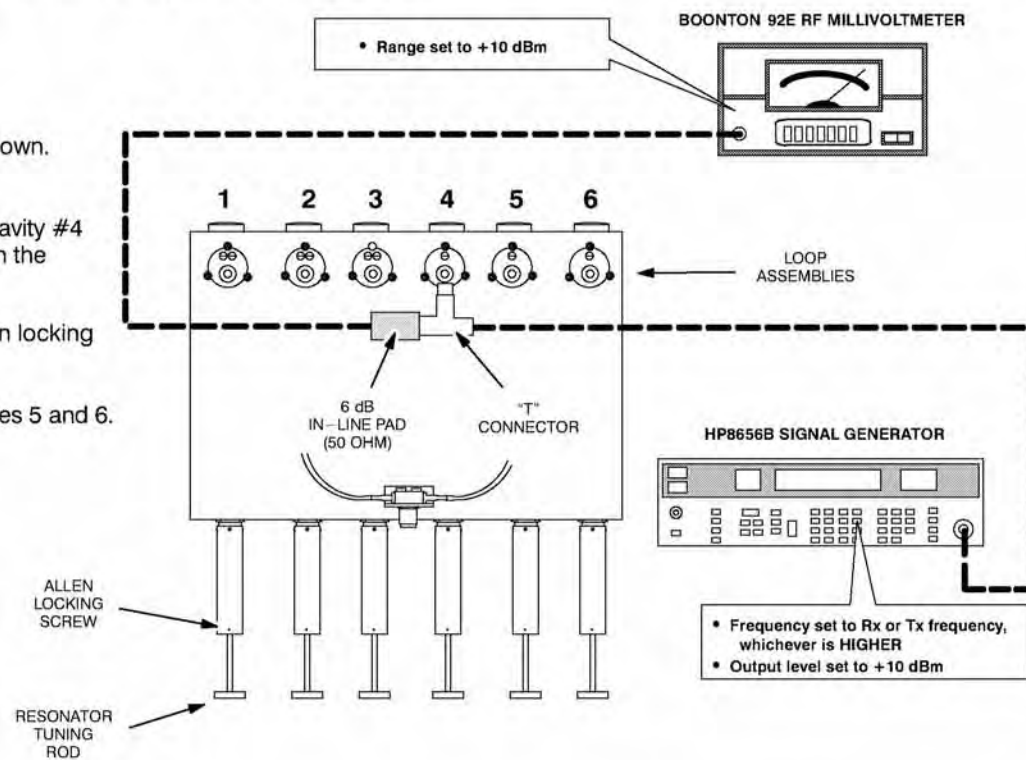

# 4 TUNING LOW NOTCH LOOP ASSEMBLIES

- 1 Set up test equipment as shown.
- 2 Use tuning tool to adjust trimmer screw for cavity #4 to obtain **minimum** reading on millivoltmeter. (Adjust trimmer screw to obtain minimum. Reduce the range on the millivoltmeter as necessary to reach true minimum reading.)
- 3 Repeat steps 1 and 2 for cavities 5 and 6.

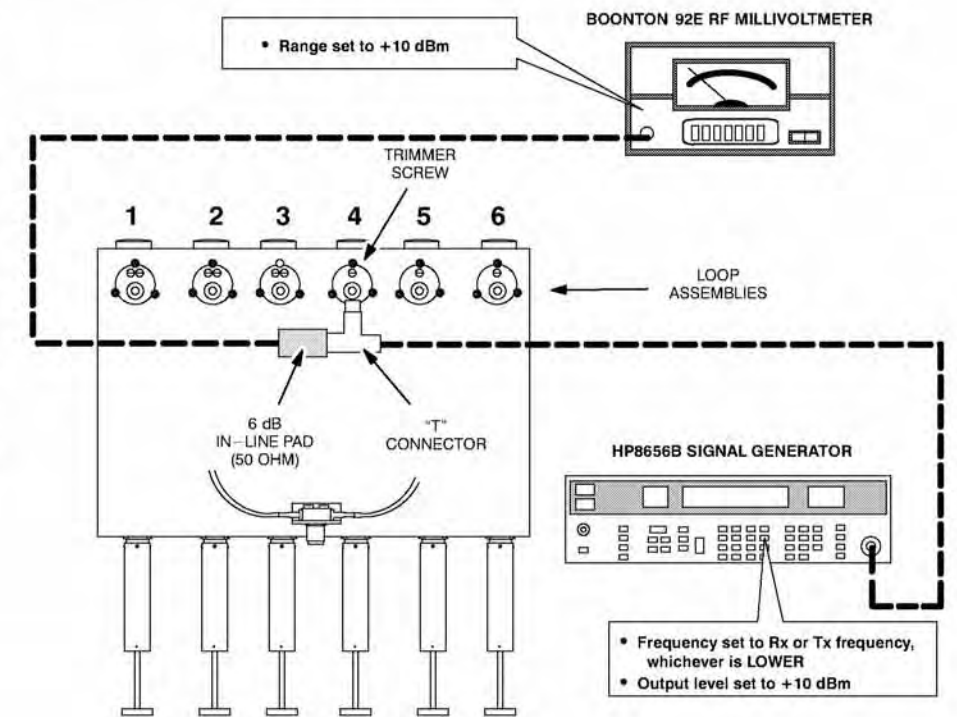
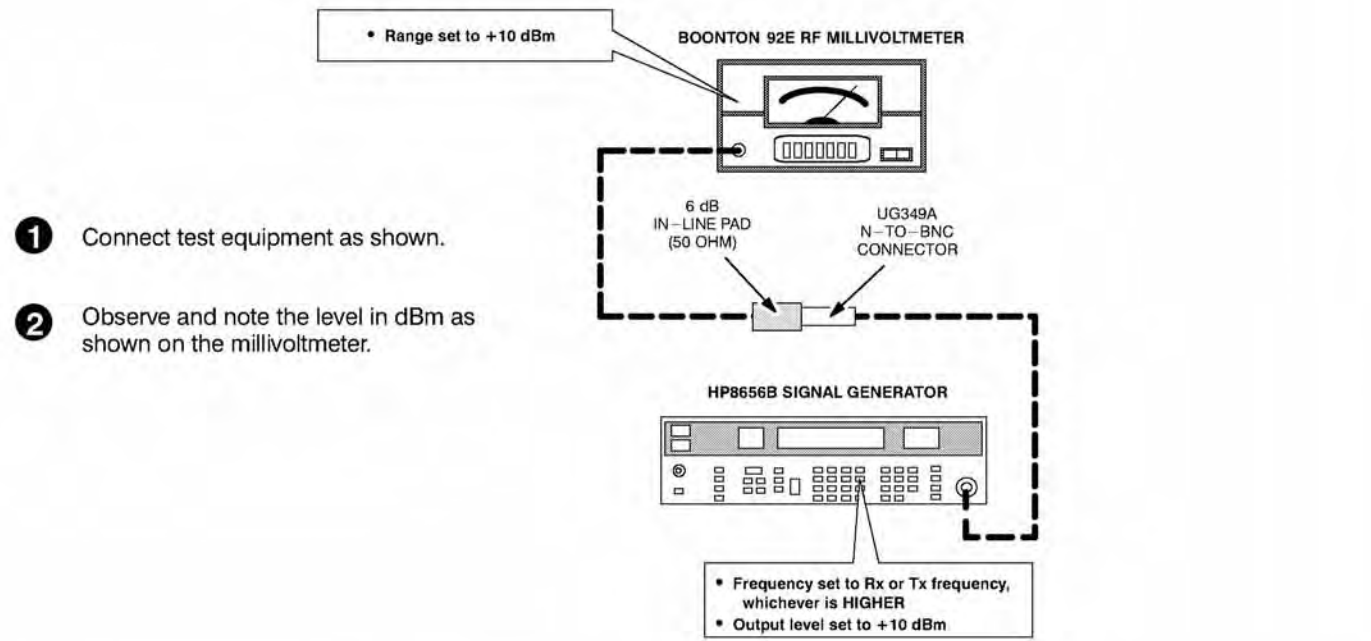

Figure 5. Quantar VHF Duplexer Field Tuning Procedure (Sheet 1 of 3)

# 5 VERIFYING INSERTION LOSS



- 1 Connect test equipment as shown.
- 2 Observe and note the level in dBm as shown on the millivoltmeter.

- 3 Connect the duplexer cable assembly and test equipment to the duplexer as shown.
- 4 Observe and note the level in dBm as shown on the millivoltmeter.
- 5 Subtract the absolute number noted in Step 2 from the number noted in Step 4. The difference should be less than 1.3 dB to meet specification for Insertion Loss.
- 6 Repeat Steps 1–5 for Low-Pass/High-Notch cavities with the following exceptions:

- 1) Set Frequency Generator for Rx or Tx frequency, whichever is **LOWER**
- 2) Connect Signal Generator to Low Pass duplexer input (cavity #1)
- 3) Connect terminator to cavity #6.

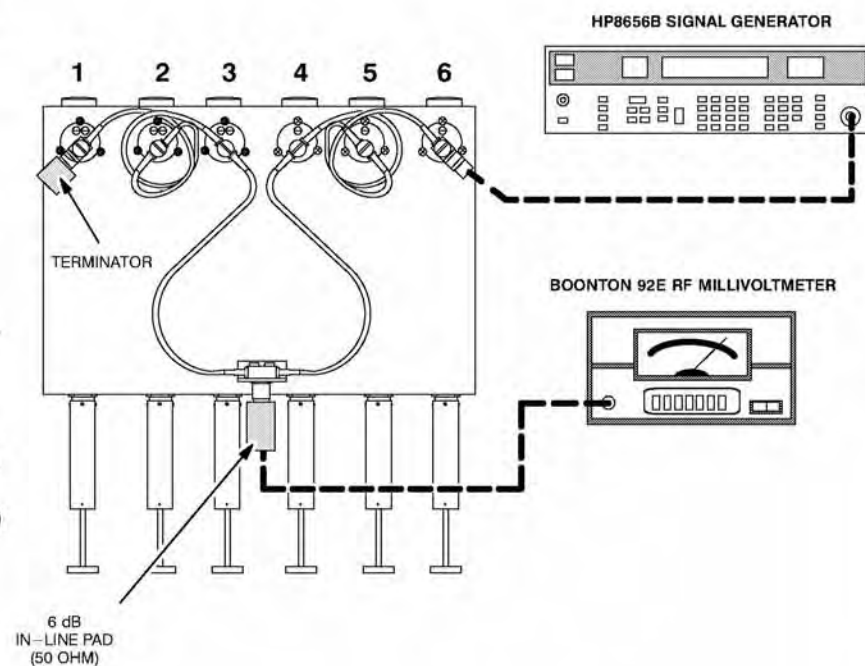

# 6 VERIFYING ISOLATION

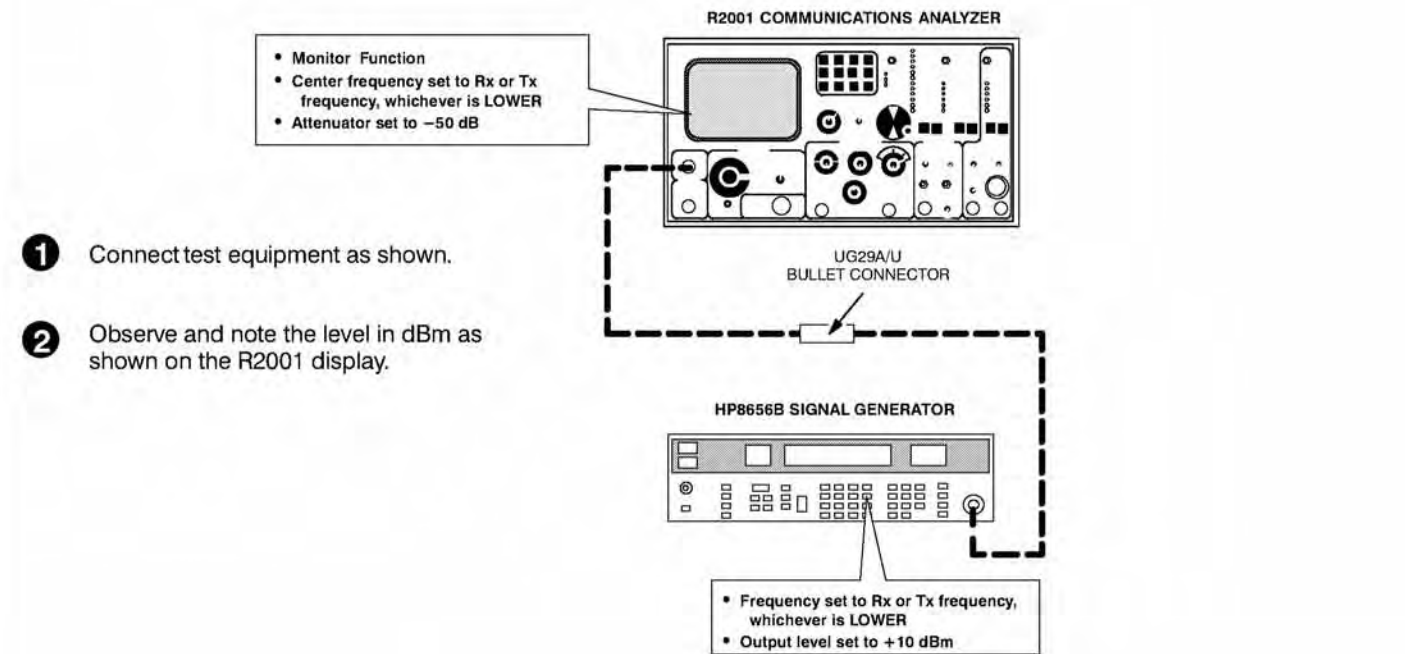

- 1 Connect test equipment as shown.
- 2 Observe and note the level in dBm as shown on the R2001 display.

- 3 Connect the test equipment to the duplexer as shown.
- 4 Observe and note the level in dBm as shown on the R2001 display. (If no number is displayed, consider isolation to be greater than 105 dB, which exceeds the specification.)
- 5 Subtract the absolute number noted in Step 4 from the number noted in Step 2. The difference should be higher than 75 dB to meet specification for Isolation.
- 6 Repeat Steps 1–5 for Low-Pass/High-Notch cavities with the following exceptions:

- 1) Set Frequency Generator and R2001 for Rx or Tx frequency, whichever is **HIGHER**
- 2) Connect Signal Generator to Low Pass duplexer input (cavity #1)
- 3) Connect terminator to cavity #6.

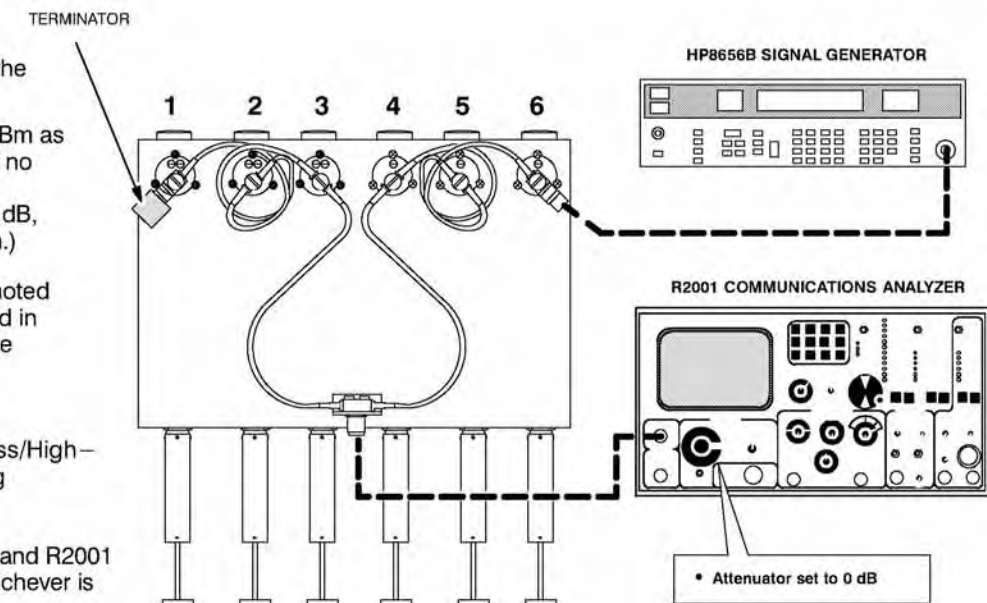
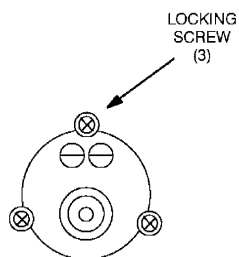

Figure 5. Quantar VHF Duplexer Field Tuning Procedure (Sheet 2 of 3)

# 7

## POST-TUNING CHECKS

- 1** Make sure all locking screws are tight. Re-install dust covers on all trimmer capacitors.



- 2** Make sure all tuning rod locking screws (6) are tight.

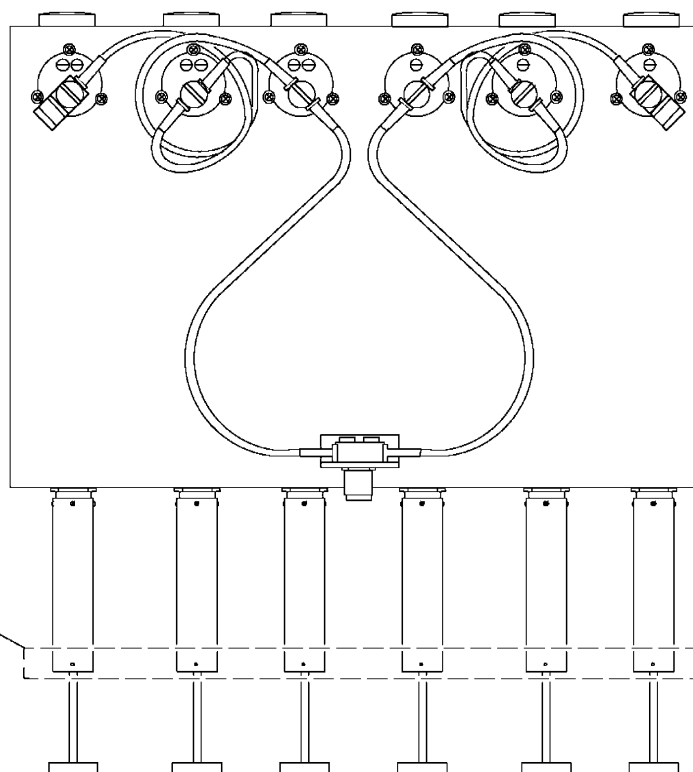

**Figure 5.** Quantar VHF Duplexer Field Tuning Procedure (Sheet 4 of 4)



# UHF DUPLEXER MODULE

Options X182BU (380–403 MHz)  
X182AC (403–435 MHz)  
X182AD (435–470 MHz)  
X182AE (470–490 MHz)  
X182AF (490–520 MHz)

## 1 DESCRIPTION

Options X182AC–AF and BU provide band–dependent duplexer modules for use with *Quantar* and *Quantro* UHF stations. This section provides a general description, identification of adjustments and inputs/outputs, performance specifications, and a typical mounting location detail. While the duplexer module is considered non–repairable, tuning screws are provided for field tuning should replacement become necessary due to module failure, or if retuning is necessary due to a change in operating channels. A single channel field tuning procedure is provided in this section.

### General Description

The duplexer module (shown in Figure 1) allows a transmit and receive channel pair to share a common TX/RX antenna. Each duplexer module consists of six resonant cavities (three for transmit and three for receive) contained in a temperature–compensated copper enclosure designed to mount in a standard EIA 19” equipment rack.

Each set of three cavities is designed and tuned to pass the respective transmit or receive channel frequency (or bandwidths) while providing maximum TX noise suppression at the RX frequency and maximum RX isolation at the TX frequency.

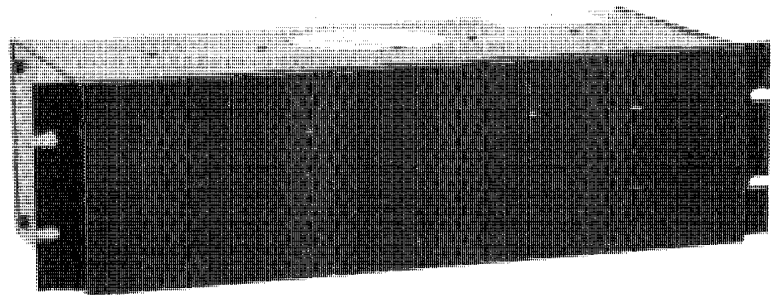

**Figure 1.** Typical UHF Duplexer Module

## 2 ADJUSTMENTS AND INPUTS/OUTPUTS

Figure 2 shows the location of the adjustment screws and rf input and output connectors for the duplexer module.

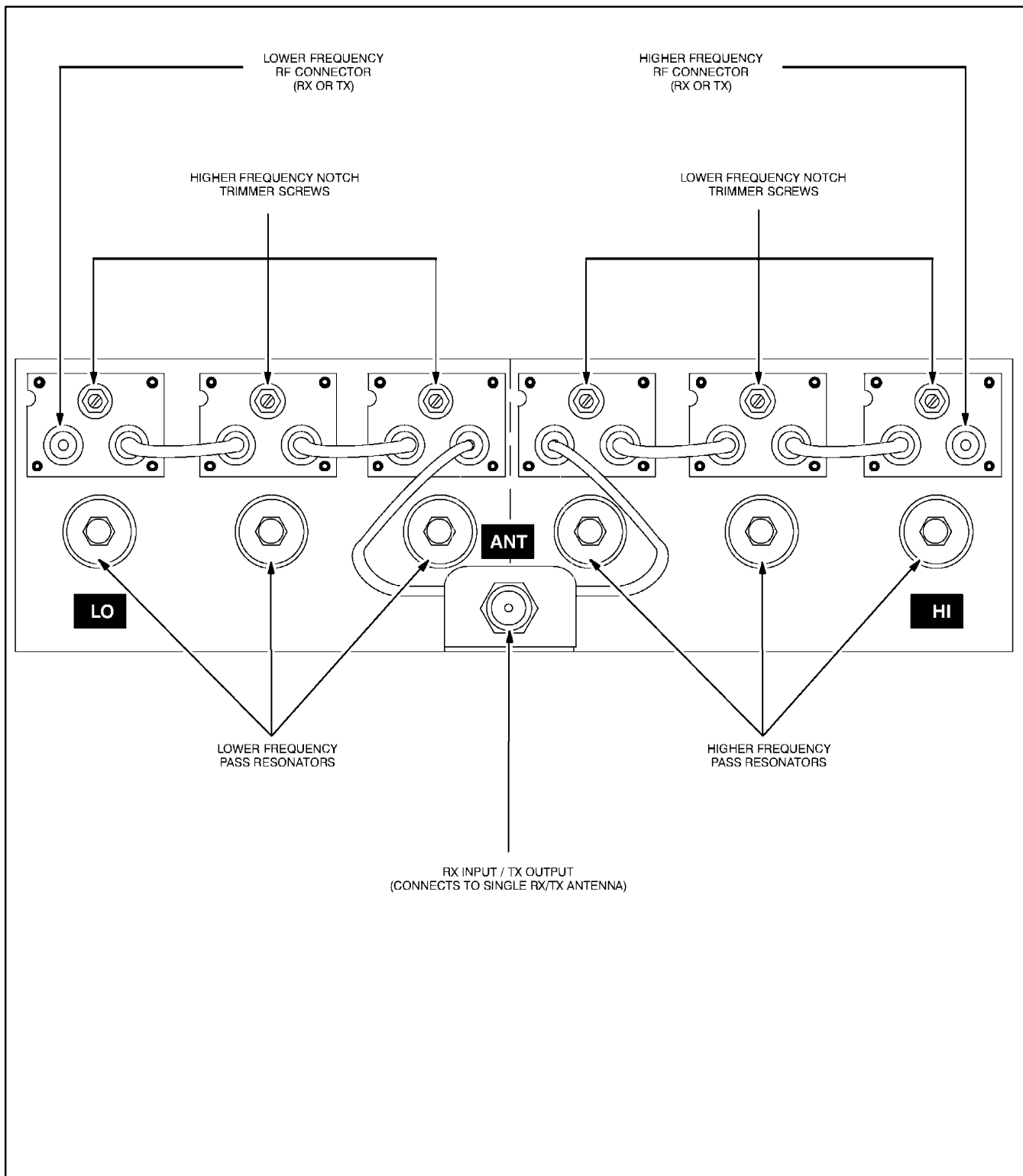

Figure 2. Quantar / Quantro UHF Duplexer Module Adjustment Screws and Input/Output Connections

### 3 PERFORMANCE SPECIFICATIONS

Table 1 shows the electrical performance specifications for the duplexer module.

#### Performance Specifications

**Table 1.** Duplexer Performance Specifications  
(Options X182AC–AF and BU)

Parameter	Specification
Operating Frequency Model X182BU Model X182AC Model X182AD Model X182AE Model X182AF	380–403 MHz 403–435 MHz 435–470 MHz 470–490 MHz 490–520 MHz
Insertion Loss (Transmitter to Antenna)	1.3 dB max
Insertion Loss (Antenna to Receiver)	1.3 dB max
TX–to–RX Frequency Separation (Min.)	5 MHz (X182AC, AD, BU) 3 MHz (X182AE, AF)
TX Noise Suppression at RX Freq.	120 dB min (X182AC, AD) 110 dB min (X182BU) 100 dB min (X182AE, AF)
RX Isolation at TX Freq.	120 dB min (X182AC, AD) 110 dB min (X182BU) 100 dB min (X182AE, AF)
Return Loss	17 dB minimum
Maximum Input Power	250 W
Temperature Range	–30°C to +60°C
Size	5¼" (H) x 14" (D) x 19" (W) EIA Rack Mountable
Weight	23 lbs.
Terminations	Female N–Type
Input and Output Impedance	50 Ohms

*SPECIFICATIONS SUBJECT TO CHANGE WITHOUT NOTICE*

## **4** TYPICAL MOUNTING CONFIGURATION

The duplexer module is typically mounted in the same rack or cabinet as the station and peripheral tray (if equipped). Figure 3 shows front and rear views of a typical repeater configuration in which a station, triple circulator option, and duplexer option are installed in a single cabinet. Also shown is a simplified interconnect diagram showing the receiver and transmitter paths to a single RX/TX antenna.

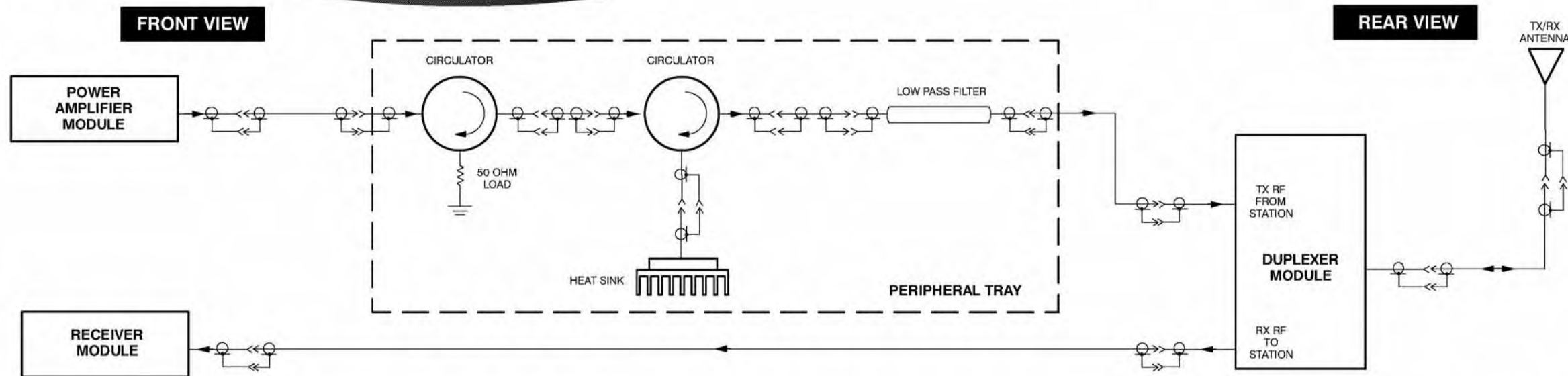
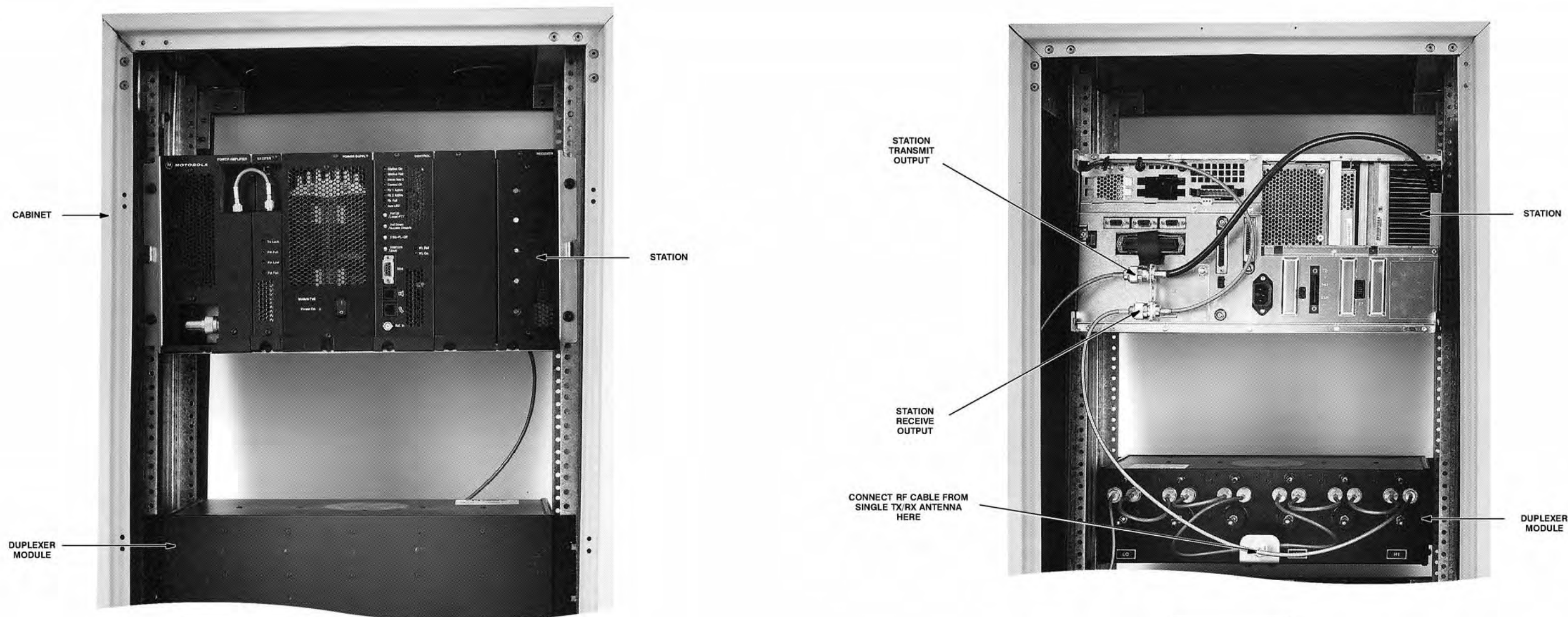

Figure 3. Typical Duplexer Mounting Configuration and Interconnect Diagram

## 5 FIELD TUNING PROCEDURE

Duplexer modules shipped with stations are tuned at the factory. If a duplexer must be replaced in the field, the unit must be installed and tuned specifically to the transmit and receive frequency pair for the particular station.

### Field Tuning Overview

**Note:** This tuning procedure is valid for channels with a bandwidth of 200 kHz or less. If bandwidth is more than 200 kHz, the duplexer must be tuned by the service depot.

The duplexer module is comprised of three low-pass/high-notch cavities and three high-pass/low-notch cavities. Each set of three cavities provides bandpass filtering for either the transmit rf signal or the receive rf signal. In general, the duplexer must be tuned so that the transmit cavity set passes the transmit signal and rejects the receive signal; concurrently, the receive cavity set must be tuned to pass the receive signal and reject the transmit signal.

Tuning is performed by injecting rf signals and making tuning adjustments (using the resonator and notch adjusting screws) while monitoring for maximum or minimum readings on the rf millivoltmeter. Field tuning the duplexer module requires the following general adjustments:

- Tune high-pass/low-notch cavities for maximum pass and reject response
- Tune low-pass/high-notch cavities for maximum pass and reject response
- Check high-pass/low-notch and low-pass/high-notch cavities for insertion loss
- Check high-pass/low-notch and low-pass/high-notch cavities for isolation

### Required Test Equipment

Field tuning of the duplexer module requires the following test equipment:

- Motorola R2001 Communications Analyzer (or equivalent)
- RF Millivoltmeter (Boonton 92E or equivalent)
- RF Signal Generator (HP8656B or equivalent)
- 50Ω N-type terminator
- Tuning tool (5/32" x 4" screwdriver)
- N-to-N bullet connector (UG29A/U or equivalent)
- 7/16" Nutdriver
- 7/16" Open End Wrench
- N-to-BNC Adapter (UG349A/U)
- N-to-N Connector (UG57B/U)

## Setting Up for Tuning Duplexer

Perform the preliminary tasks shown in Figure 4 to prepare for tuning the duplexer module.

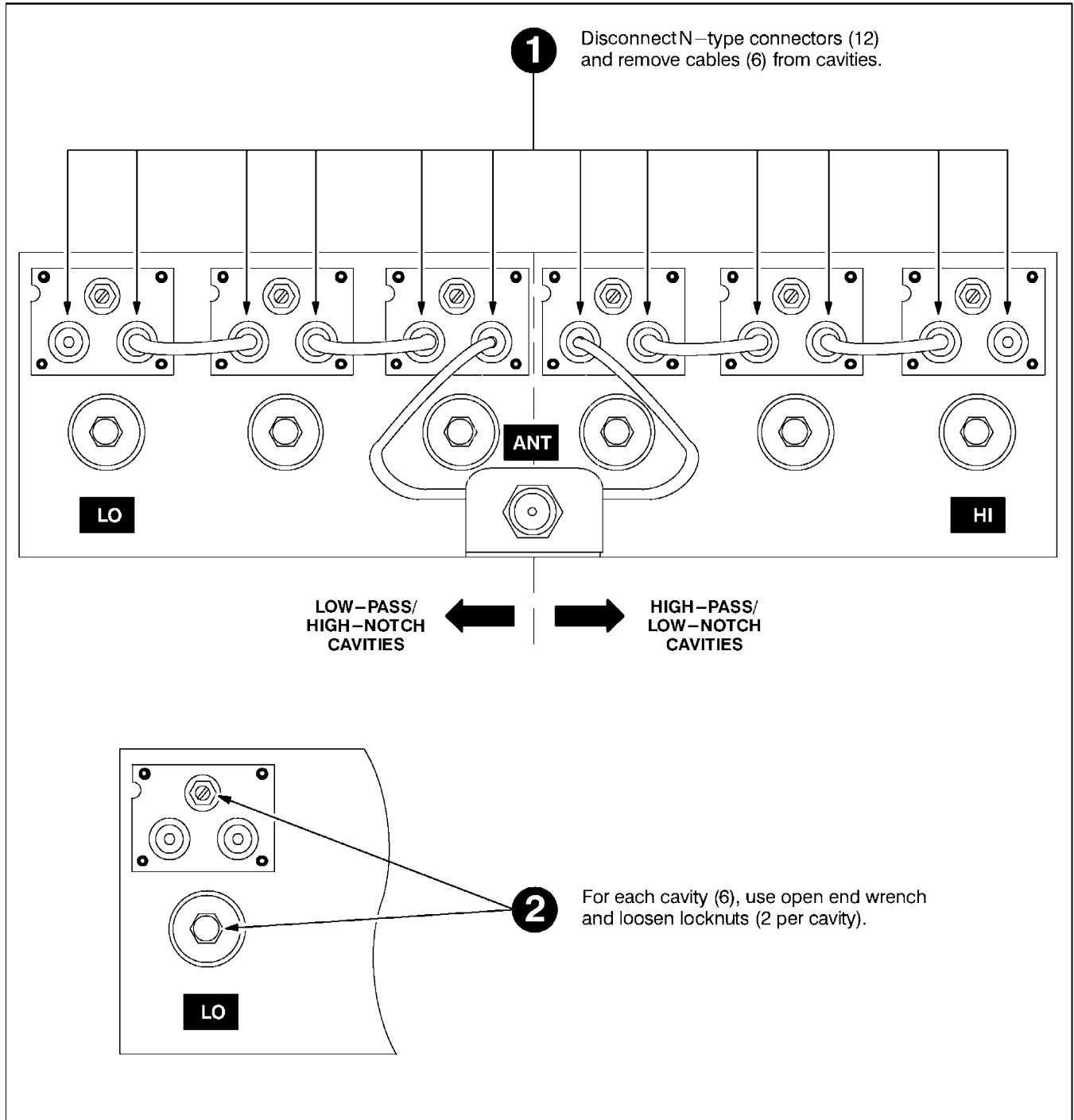

**Figure 4.** Preliminary Tasks Prior to Tuning Duplexer

---

## Duplexer Tuning Procedure

The duplexer field tuning procedures are provided in Figure 5. The procedures are most easily performed with the duplexer module removed from the station rack or cabinet. Be sure to make note of the transmit and receive frequencies for the particular station before beginning.

If the duplexer module is tuned according to instructions and does not meet specifications for return loss, insertion loss, and/or isolation, you must return the duplexer for repair.



# 1 TUNING LOW PASS RESONATORS

- 1 Set up test equipment as shown.
- 2 Use nut driver to adjust pass adjustment screw for cavity #1 to obtain a **PEAK** reading on the millivoltmeter
- 3 Use open end wrench and tighten lock nut *carefully*, making sure pass adjustment screw does not shift position.
- 4 Repeat steps 2 & 3 for cavities 2 and 3.

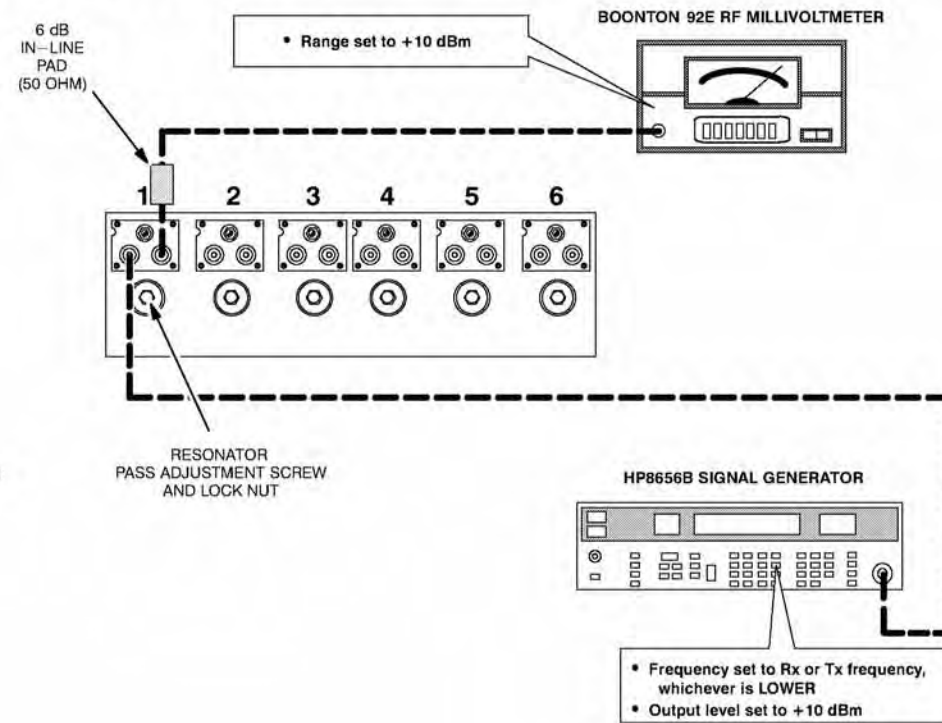

# 3 TUNING HIGH NOTCH LOOP ASSEMBLIES

- 1 Set up test equipment as shown.
- 2 Use screwdriver to adjust notch adjustment screw for cavity #1 to obtain a **minimum** reading on the millivoltmeter ( Reduce the range on the millivoltmeter as necessary to reach true minimum reading.)
- 3 Use open end wrench and tighten lock nut *carefully*, making sure notch adjustment screw does not shift position.
- 4 Repeat steps 2 & 3 for cavities 2 and 3.

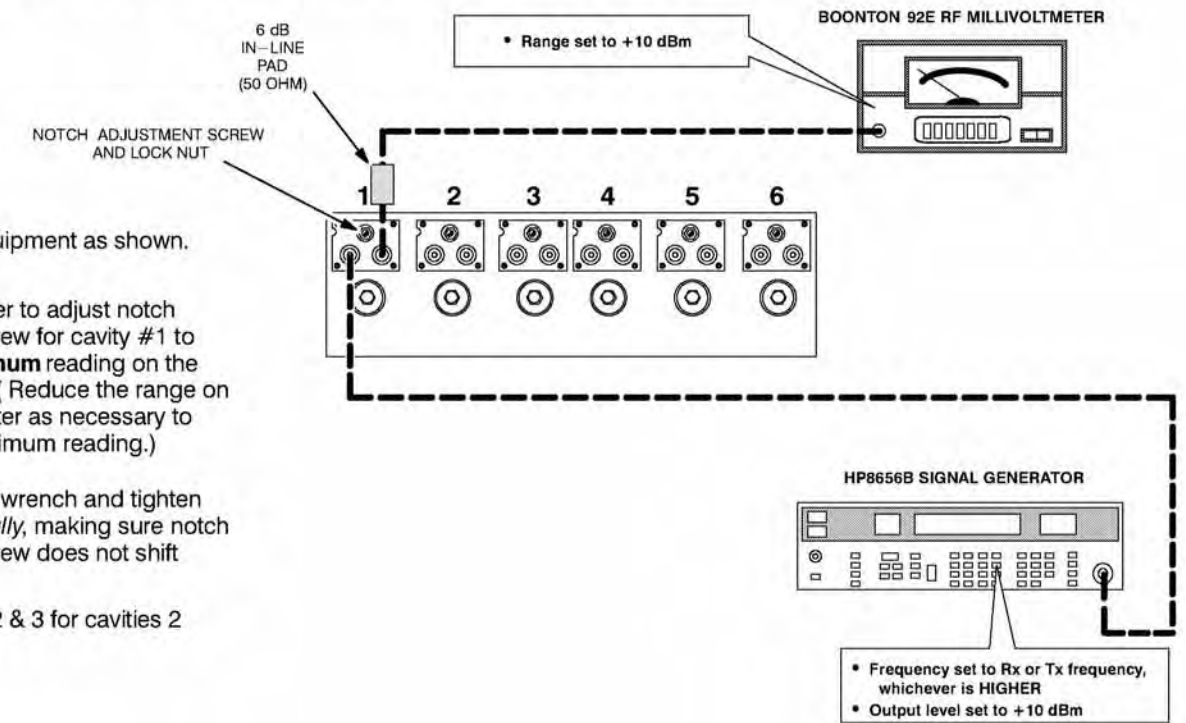

# 2 TUNING HIGH PASS RESONATORS

- 1 Set up test equipment as shown.
- 2 Use nut driver to adjust pass adjustment screw for cavity #4 to obtain a **PEAK** reading on the millivoltmeter
- 3 Use open end wrench and tighten lock nut *carefully*, making sure pass adjustment screw does not shift position.
- 4 Repeat steps 2 & 3 for cavities 5 and 6.

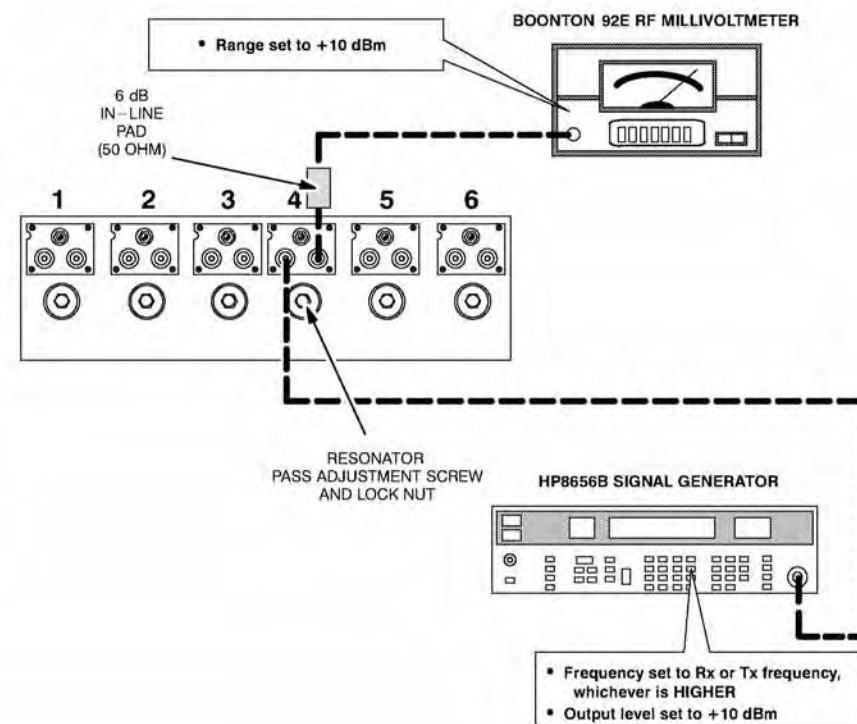

# 4 TUNING LOW NOTCH LOOP ASSEMBLIES

- 1 Set up test equipment as shown.
- 2 Use screwdriver to adjust notch adjustment screw for cavity #4 to obtain a **minimum** reading on the millivoltmeter ( Reduce the range on the millivoltmeter as necessary to reach true minimum reading.)
- 3 Use open end wrench and tighten lock nut *carefully*, making sure notch adjustment screw does not shift position.
- 4 Repeat steps 2 & 3 for cavities 5 and 6.

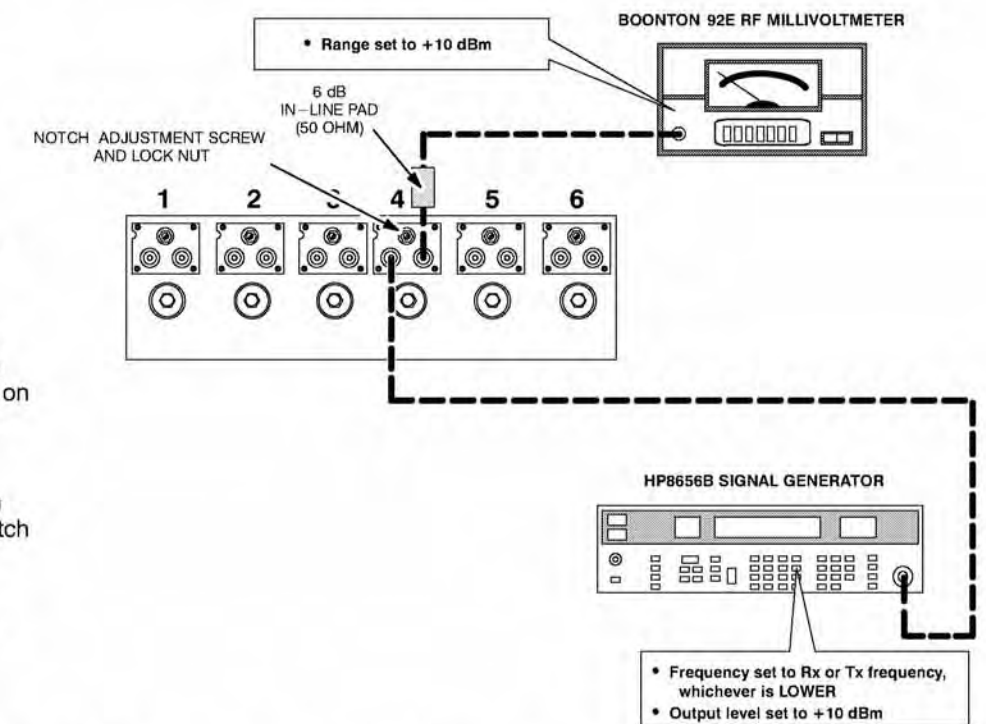
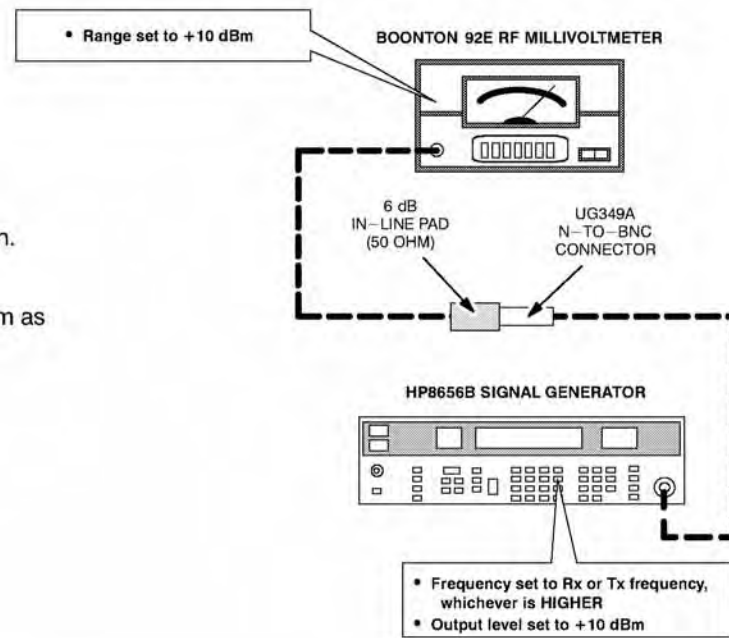

Figure 5. Quantar / Quantro UHF Duplexer Field Tuning Procedure (Sheet 1 of 3)

# 5 VERIFYING INSERTION LOSS

- 1 Connect test equipment as shown.
- 2 Observe and note the level in dBm as shown on the millivoltmeter.



- 3 Connect the duplexer cables and test equipment to the duplexer as shown.
- 4 Observe and note the level in dBm as shown on the millivoltmeter.
- 5 Subtract the absolute number noted in Step 2 from the number noted in Step 4. The difference should be less than 1.3 dB to meet specification for Insertion Loss.
- 6 Repeat Steps 1–5 for Low–Pass/High–Notch cavities with the following exceptions:

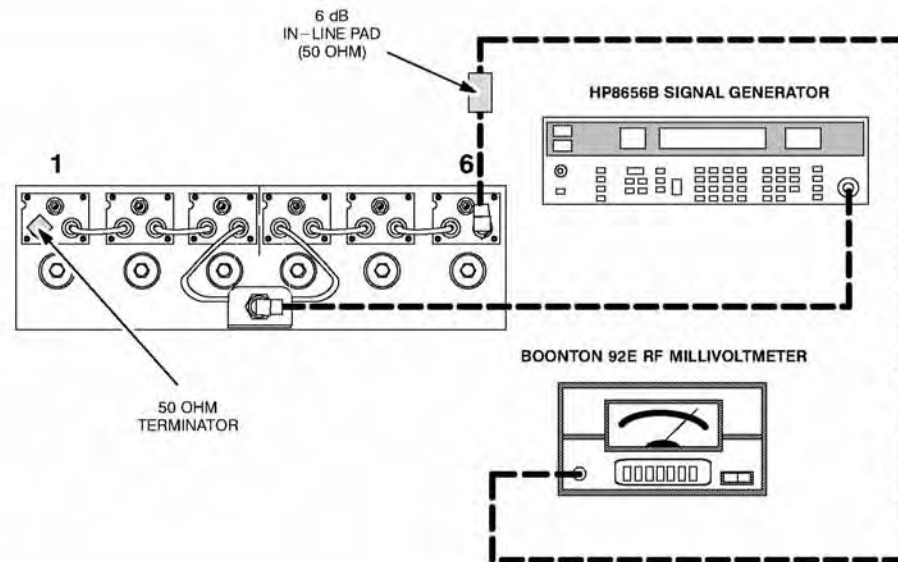

- 1) Set Frequency Generator for Rx or Tx frequency, whichever is **LOWER**
- 2) Connect Millivoltmeter to Low Pass duplexer input (cavity #1)
- 3) Connect terminator to cavity #6.

# 6 VERIFYING ISOLATION

- 1 Connect test equipment as shown.
- 2 Observe and note the level in dBm as shown on the R2001 display.

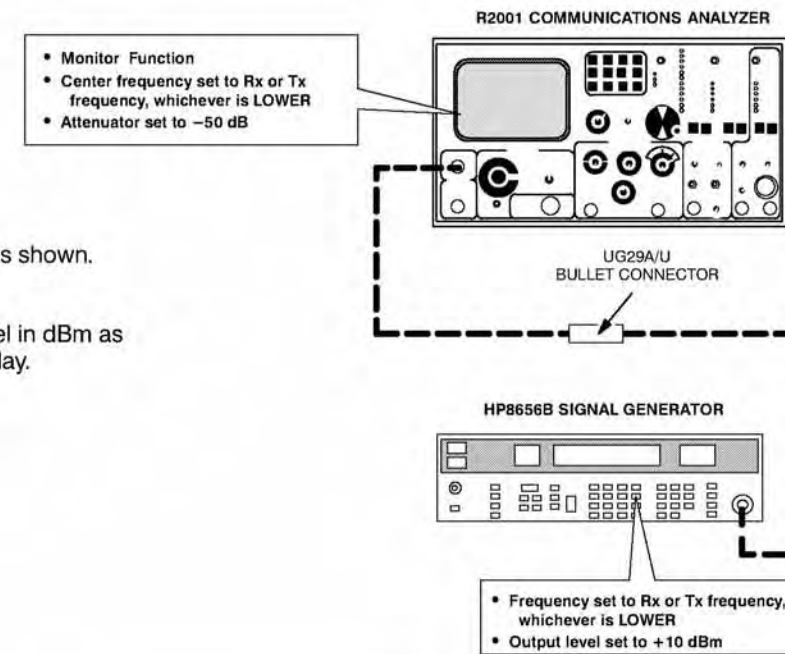

- 3 Connect the test equipment to the duplexer as shown.
- 4 Observe and note the level in dBm as shown on the R2001 display. (If no number is displayed, consider isolation to be greater than 105 dB, which exceeds the specification.)
- 5 Subtract the absolute number noted in Step 4 from the number noted in Step 2. The difference should be higher than 100 dB to meet specification for Isolation.

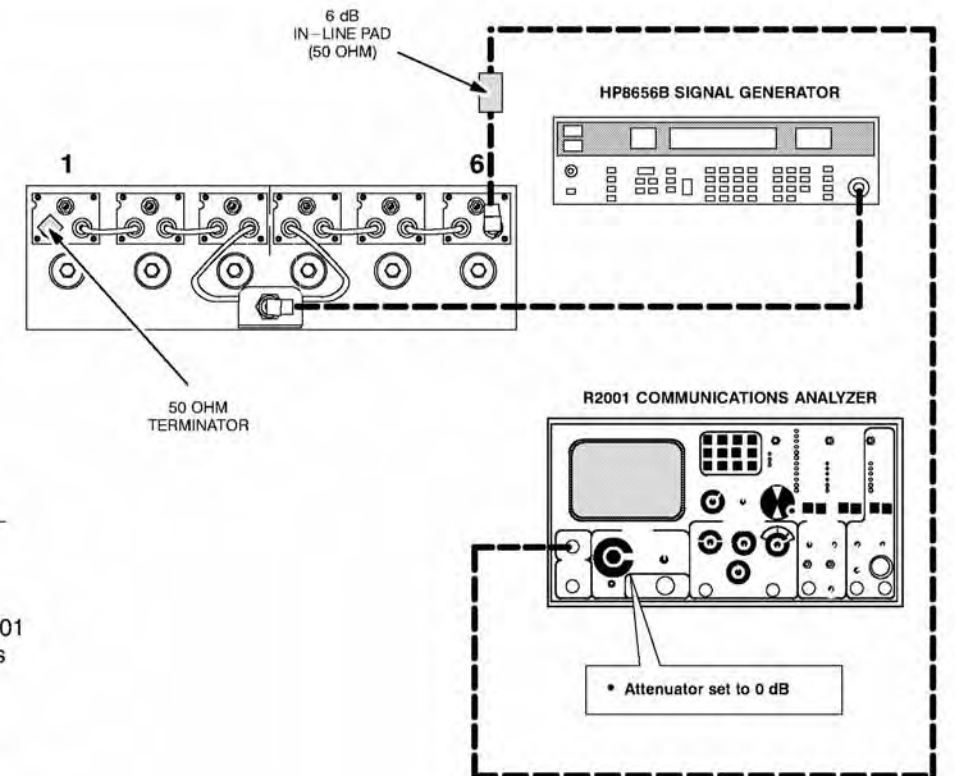

- 6 Repeat Steps 1–5 for Low–Pass/High–Notch cavities with the following exceptions:
  - 1) Set Frequency Generator and R2001 for Rx or Tx frequency, whichever is **HIGHER**
  - 2) Connect R2001 to Low Pass duplexer input (cavity #1)
  - 3) Connect terminator to cavity #6.

Figure 5. Quantar / Quantro UHF Duplexer Field Tuning Procedure (Sheet 2 of 3)

# 7

## POST-TUNING CHECKS

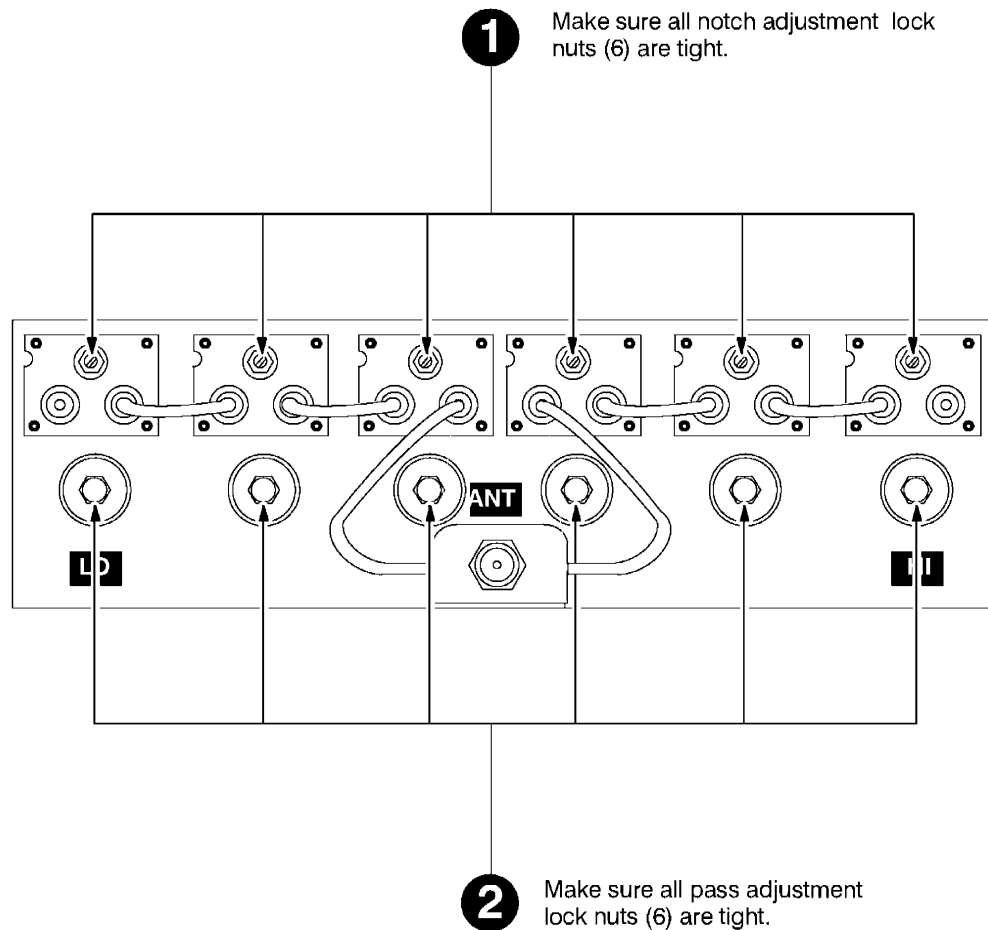

**Figure 5.** Quantar/Quantro UHF Duplexer Field Tuning Procedure (Sheet 3 of 3)

**Options X182AG**

RX (806–824 MHz)

TX (851–869 MHz)

**X182AH**

RX (896–902 MHz)

TX (935–941 MHz)

## 1 DESCRIPTION

Options X182AG and X182AH provide a duplexer module for use with *Quantar* 800 MHz and 900 MHz stations, respectively. This section provides a general description, identification of inputs/outputs, performance specifications, and a typical mounting location detail. The duplexer module is considered non-repairable and requires no field tuning.

### General Description

The duplexer module (shown in Figure 1) allows a transmit and receive channel pair to share a common TX/RX antenna. Each duplexer module consists of ten resonant cavities (five for transmit and five for receive) contained in a temperature-compensated copper enclosure designed to mount in a standard EIA 19" equipment rack.

Each set of five cavities is designed and tuned to pass the respective transmit or receive channel frequency (or bandwidths) while providing maximum TX noise suppression at the RX frequency and maximum RX isolation at the TX frequency.

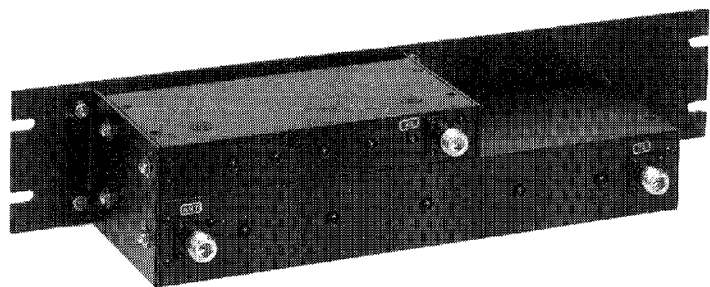

**Figure 1.** Typical 900 MHz Duplexer Module

## 2 INPUTS/OUTPUTS

Figure 2 shows the input and output rf connectors for the duplexer module.

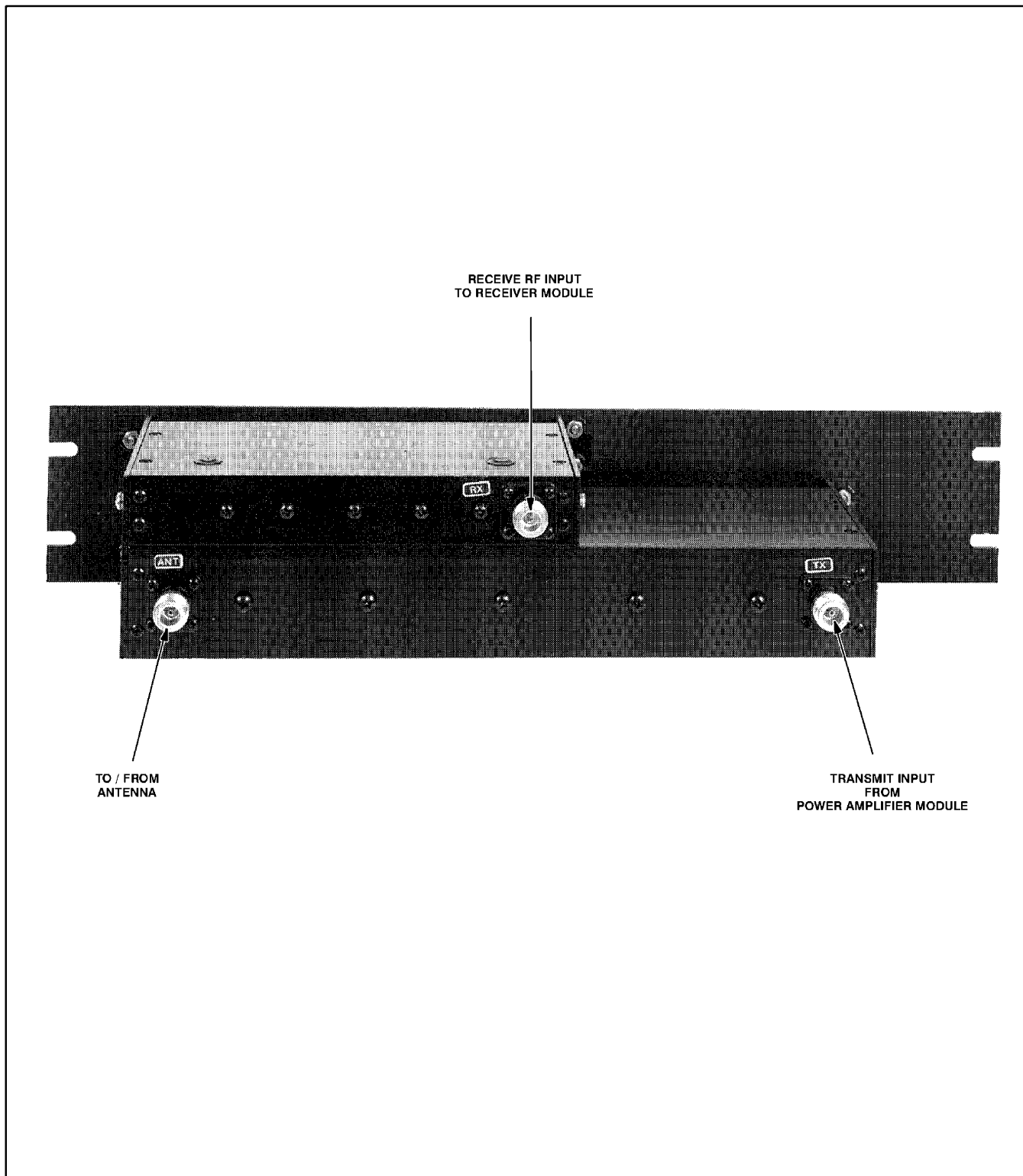

**Figure 2.** Quantar 800 MHz/900 MHz Duplexer Module Input/Output Connections

### 3 PERFORMANCE SPECIFICATIONS

Table 1 and Table 2 show the electrical performance specifications for the 800 MHz and 900 MHz duplexer modules.

**Table 1.** Duplexer Performance Specifications (Option X182AG)

Parameter	Specification
Operating Frequency	806–869 MHz
Insertion Loss (Transmitter to Antenna)	1.0 dB max
Insertion Loss (Antenna to Receiver)	1.0 dB max
Frequency Passband	RX 806–824 MHz TX 851–869 MHz
TX Noise Suppression at RX Freq.	80 dB min
RX Isolation at TX Freq.	80 dB min
Frequency Separation	45 MHz
Return Loss	14 dB minimum
Maximum Input Power	500 W
Temperature Range	–30°C to +60°C
Size with rack mounting panel	3½" (H) x 5¾" (D) x 19" (W) EIA Rack Mountable
Weight with rack mounting panel	7.5 lbs.
Terminations	Female N–Type
Input and Output Impedance	50 Ohms

**Table 2.** Duplexer Performance Specifications (Option X182AH)

Parameter	Specification
Operating Frequency	896–941 MHz
Insertion Loss (Transmitter to Antenna)	1.0 dB max
Insertion Loss (Antenna to Receiver)	1.0 dB max
Frequency Passband	RX 896–902 MHz TX 935–941 MHz
TX Noise Suppression at RX Freq.	75 dB min
RX Isolation at TX Freq.	75 dB min
Frequency Separation	39 MHz
Return Loss	15 dB minimum
Maximum Input Power	500 W
Temperature Range	–30°C to +60°C
Size with rack mounting panel	3½" (H) x 5¾" (D) x 19" (W) EIA Rack Mountable
Weight with rack mounting panel	7.5 lbs.
Terminations	Female N–Type
Input and Output Impedance	50 Ohms

SPECIFICATIONS SUBJECT TO CHANGE WITHOUT NOTICE

## **4** TYPICAL MOUNTING CONFIGURATION

The duplexer module is typically mounted in the same rack or cabinet as the station and peripheral tray (if equipped). Figure 3 shows front and rear views of a typical repeater configuration in which a station, triple circulator option, and duplexer option are installed in a single cabinet. Also shown is a simplified interconnect diagram showing the receiver and transmitter paths to a single RX/TX antenna.

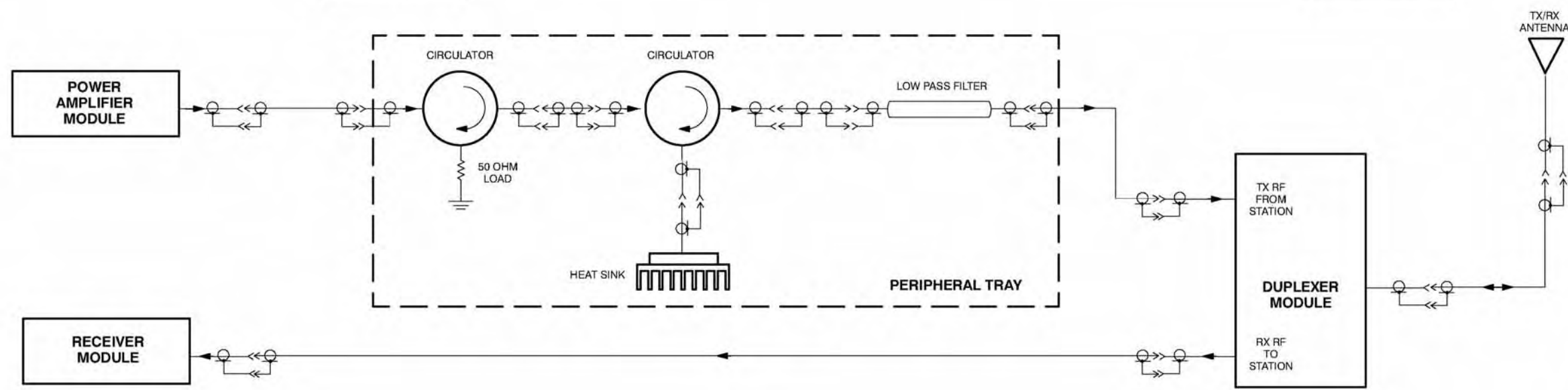
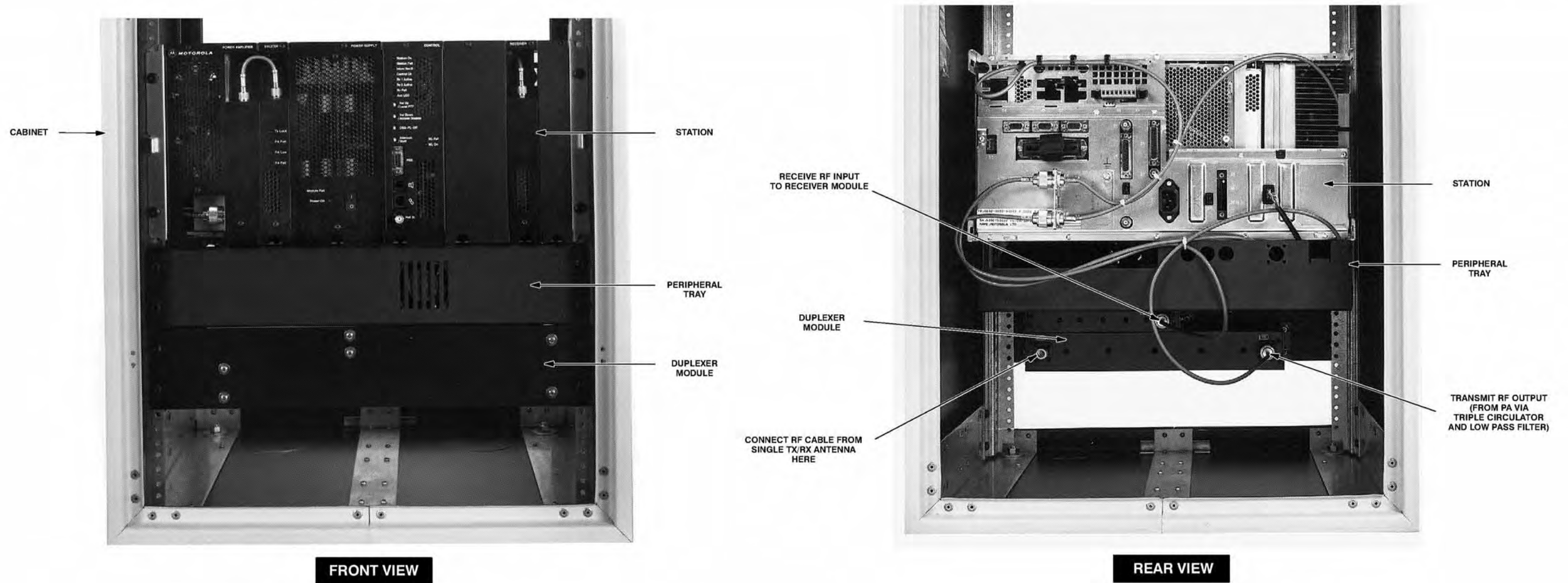
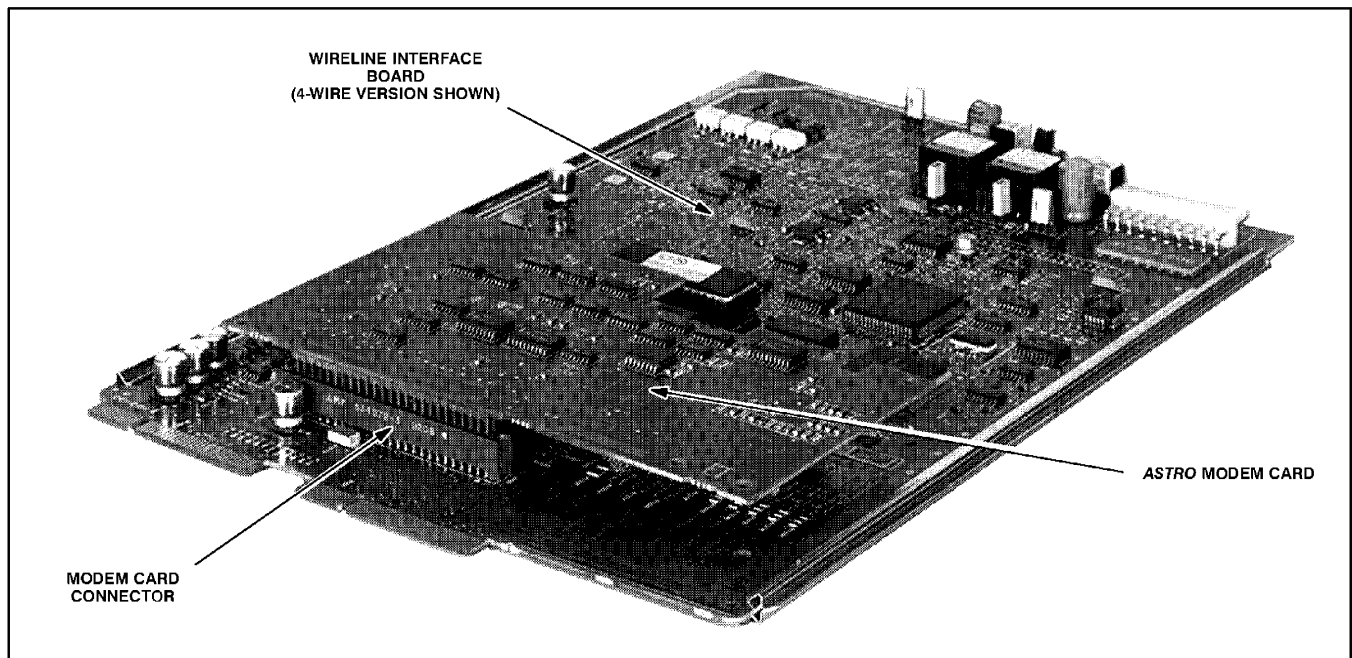

Figure 3. Typical Duplexer Mounting Configuration and Interconnect Diagram





**Figure 1.** ASTRO Modem Card Installed on Wireline Interface Board

## 1 DESCRIPTION

Option X437AA provides a single *ASTRO* Modem Card for use with *Quantar* station products. The *ASTRO* Modem Card provides the interface between the station and the wireline in systems using *ASTRO* 9.6 kbps signaling. The card connects to the Wireline Interface Board, as shown in Figure 1. Note that 8-wire Wireline Interface Boards are equipped with connectors for two *ASTRO* modem cards.

### General Description

**Note:** The *ASTRO* modem card contains no jumpers or switches and requires no adjustments. The card is auto-configured upon station power-up.

The modem card accepts *ASTRO* modem signaling from the wireline and converts the signal to detected data, which is then fed to the Station Control Module for further processing. Data from the Station Control Module is fed to the modem card, which converts the signal to an *ASTRO* modem signal and outputs the signal to the wireline. (Refer to the Wireline Interface Board sections in this manual for block diagrams showing the interface between the *ASTRO* modem card and the wireline/station.)

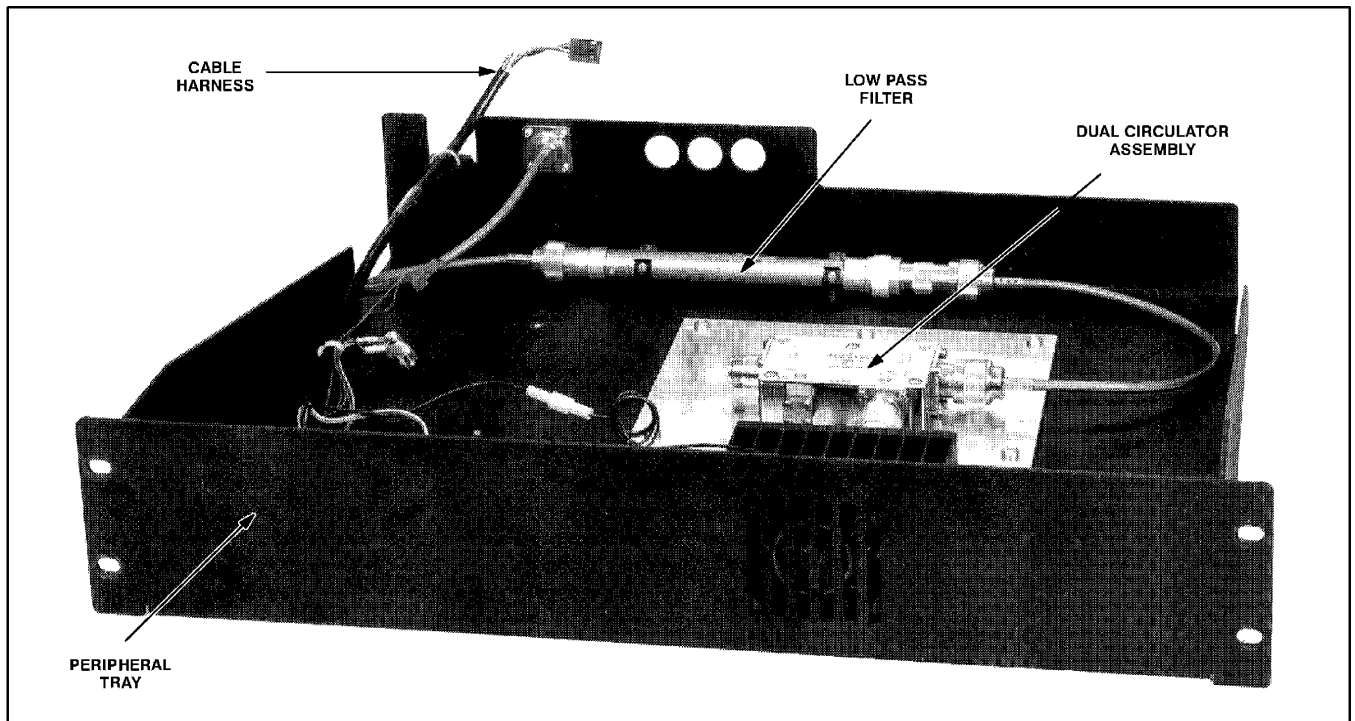

**Figure 1.** Peripheral Tray with Internal Components (900 MHz Components Shown)

## **1** DESCRIPTION

Option X696AA provides a peripheral tray and cable harness for use with *Quantar* station products. This section provides a general description, option complement, and identification of inputs/outputs. The information provided is sufficient to give service personnel a functional understanding of the module, allowing maintenance and troubleshooting to the module level. (Refer also to the Maintenance and Troubleshooting section of this manual for detailed troubleshooting procedures for all modules in the station.)

### **General Description**

The peripheral tray is comprised of a rack-mount tray. The tray (shown in Figure 1) allows various ancillary equipment (circulators, filters, etc.) to be housed and electrically connected to the station.

## 2 OPTIONS COMPLEMENT

Table 1 shows the contents for the Option X696AA Peripheral Tray option.

---

### Option Complement Chart

**Table 1.** Peripheral Tray Option X696AA Complement

Model/Part No.	Description
TRN7751A	Peripheral Tray Assembly
0383498N08	Self-tapping screws (4)
2785203U01	Peripheral Tray Shelf

### 3 PERIPHERAL TRAY CONTENTS AND INPUTS/OUTPUTS

Figure 2 shows the Peripheral Tray equipped with dual circulator assembly and low pass filter.

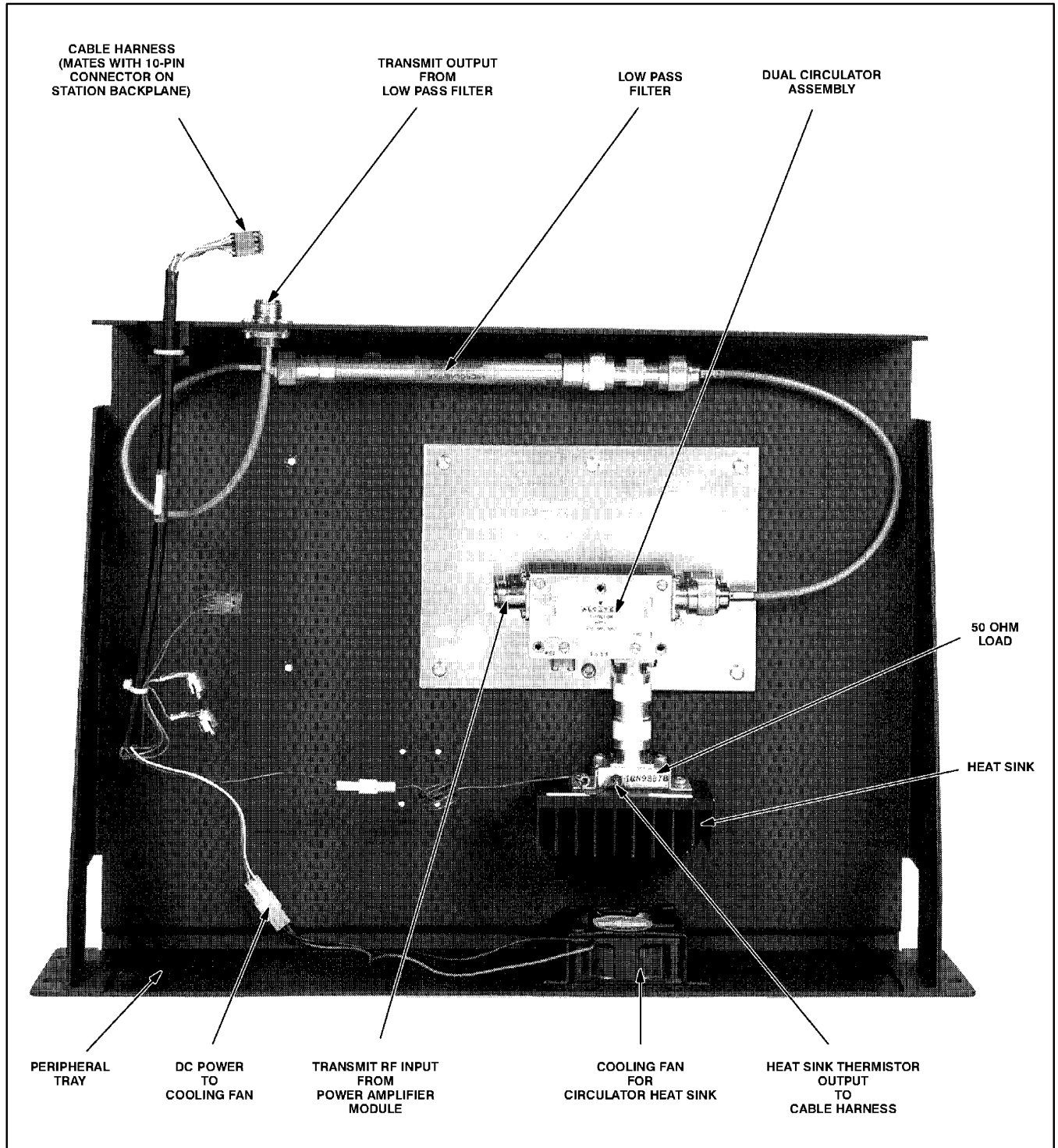

**Figure 2.** Peripheral Tray Contents and Inputs and Outputs (900 MHz Circulator and Low Pass Filter Shown)



**MOTOROLA**

# ULTRA HIGH STABILITY OSCILLATOR (UHSO) MODULE (Internal)

Option X873AA

## 1

## DESCRIPTION

The Option X873AA UHSO Module is described in this section. A general description, identification of inputs/outputs, functional block diagram, and functional theory of operation are provided. The information provided is sufficient to give service personnel a functional understanding of the module, allowing maintenance and troubleshooting to the module level. (Refer also to the Troubleshooting section of this manual for detailed troubleshooting procedures for all modules in the station.)

### General Description

The X873AA Option provides an Ultra-High Stability Oscillator Module which significantly increases the frequency accuracy of the station's internal frequency reference circuitry (located on the Station Control Module). The UHSO module is designed to slide into the 2nd receiver slot of the station card cage and is powered by the station power supply (via the backplane).

The module consists of a sealed ovenized element, voltage regulator circuitry, and control and diagnostics circuitry.

## 2 IDENTIFICATION OF INPUTS/OUTPUTS

Figure 1 shows the UHSO Module input and output external connections.

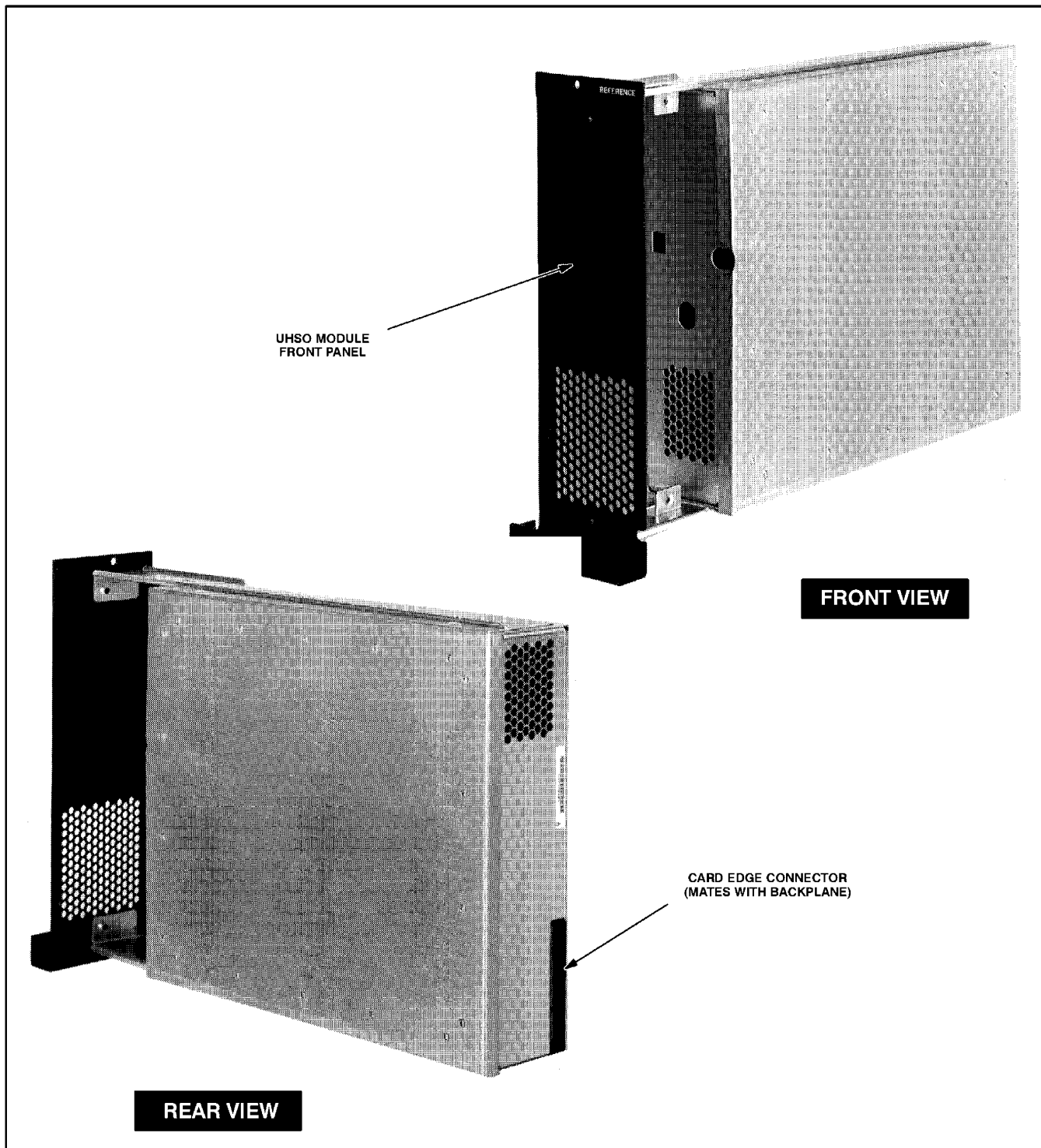

Figure 1. UHSO Module Inputs and Outputs

# 3

## FUNCTIONAL THEORY OF OPERATION

The following theory of operation describes the operation of the UHSO Module circuitry at a functional level. The information is presented to give the service technician a basic understanding of the functions performed by the module in order to facilitate maintenance and troubleshooting to the module level. Refer to the block diagram shown in Figure 2.

### +10V Regulator Circuitry

A series pass regulator circuit accepts +14.2 V from the backplane and generates a +10 V dc supply voltage. This +10 V is used to power the ovenized 5 MHz element as well as other circuitry on the UHSO board.

### 5 MHz Oscillator Circuitry

A sealed ovenized 5 MHz element provides a highly stable 5 MHz reference output. This output is fed to the Station Control Module (via the backplane) and is used to control the reference oscillator circuitry (located on the SCM board) to maintain improved frequency accuracy. A sample of the 5 MHz signal is fed to one of the A/D converter inputs (p/o Diagnostics Circuitry).

The ovenized element also generates a +8V dc voltage. This +8V is used to power the buffers associated with the steering voltage, and allows the steering voltage and ovenized element to “track”, eliminating the need for additional temperature compensation. The +8V dc voltage is also scaled and buffered to provide a +8V sample which is fed to one of the A/D converter inputs (p/o Diagnostics Circuitry).

### Control Circuitry

The control circuitry accepts 12 bits of data from the Station Control Module (via the SPI bus) and outputs a corresponding dc voltage. This voltage is scaled and buffered and output as a dc steering voltage which controls the frequency output of the 5 MHz oscillator. [Note that this is not a closed feedback loop system. The 12 bits are sent only during station power up and when performing the reference oscillator calibration procedure (using the RSS).]

The dc steering voltage is also scaled and buffered to provide a steering voltage sample which is fed to one of the A/D converter inputs (p/o Diagnostics Circuitry).

---

## Address Decode Circuitry

The address decode circuitry allows the Station Control Board to use the address bus to select a specific device on a specific station board for control or data communications purposes (via the SPI bus). If the board select circuitry decodes address lines A2 thru A5 as the UHSO module address, it enables the chip select circuitry. The chip select circuitry then decodes address lines A0 and A1 and generates chip select signals for the D/A and A/D converters.

---

## Diagnostics Circuitry

Various dc voltages and sample signals are input to an A/D converter which converts the signals to a binary representation. The data is then sent to the Station Control Module (via the SPI bus) for monitoring and diagnostics purposes.



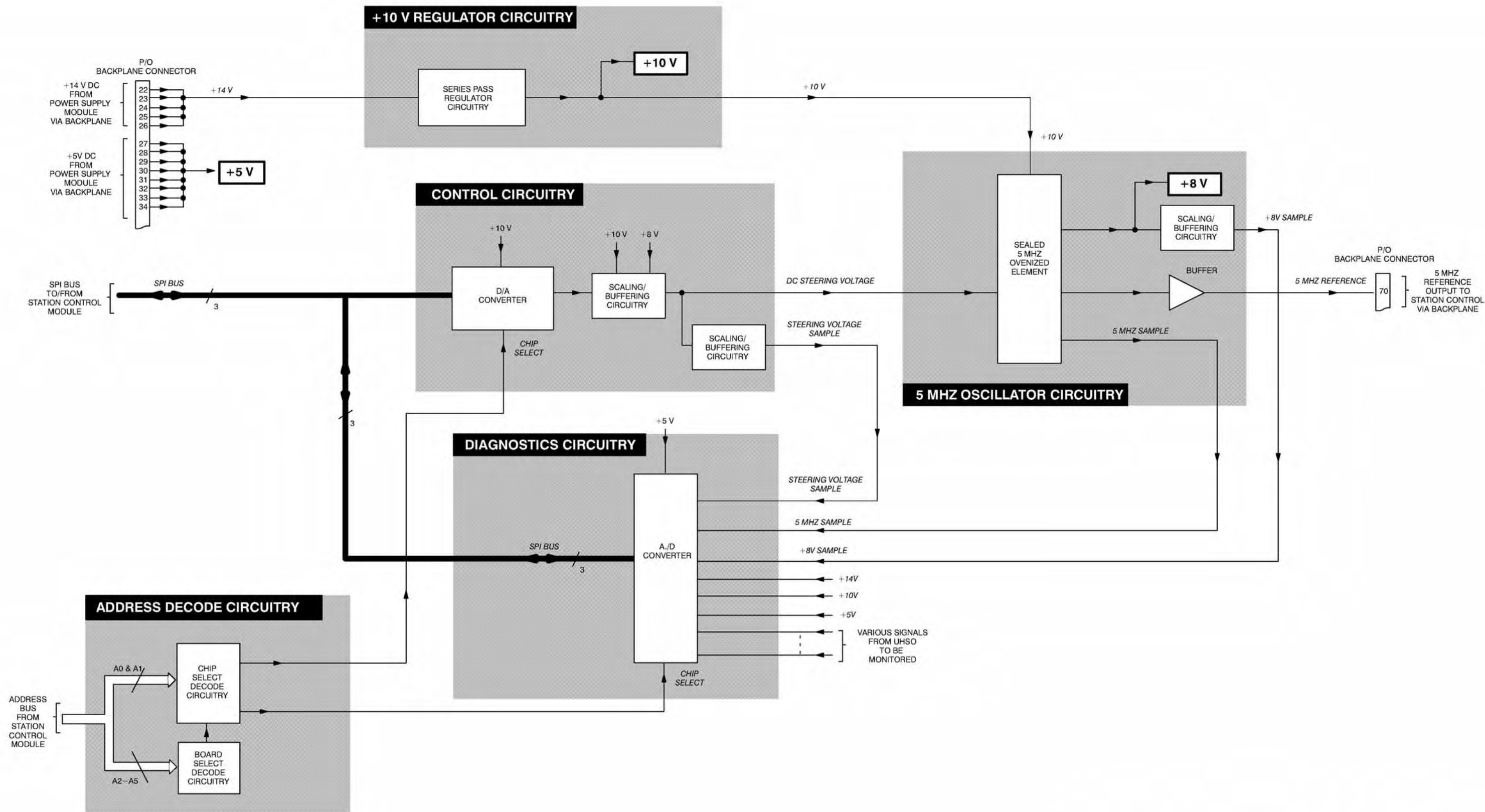

Figure 2. Internal UHSO Module Functional Block Diagram

# RA/RT CONFIGURATION (TRC CONTROL)

For *Quantar* and *Quantro* Stations

## 1 OVERVIEW

The RA/RT (TRC control) configuration allows a *Quantar/Quantro* station to be TRC controlled by a remote console using either a radio link or a microwave link in place of the usual wireline link. This configuration is typically used in cases where the station is located in a relatively inaccessible location (such as a mountain top) where running phone lines is either impractical or impossible.

As shown in Figure 1A, a pair of stations (called station 1 and station 2) is used to substitute for the normal wireline connections between the repeater station and the console. Figure 1B shows a microwave RA/RT link.

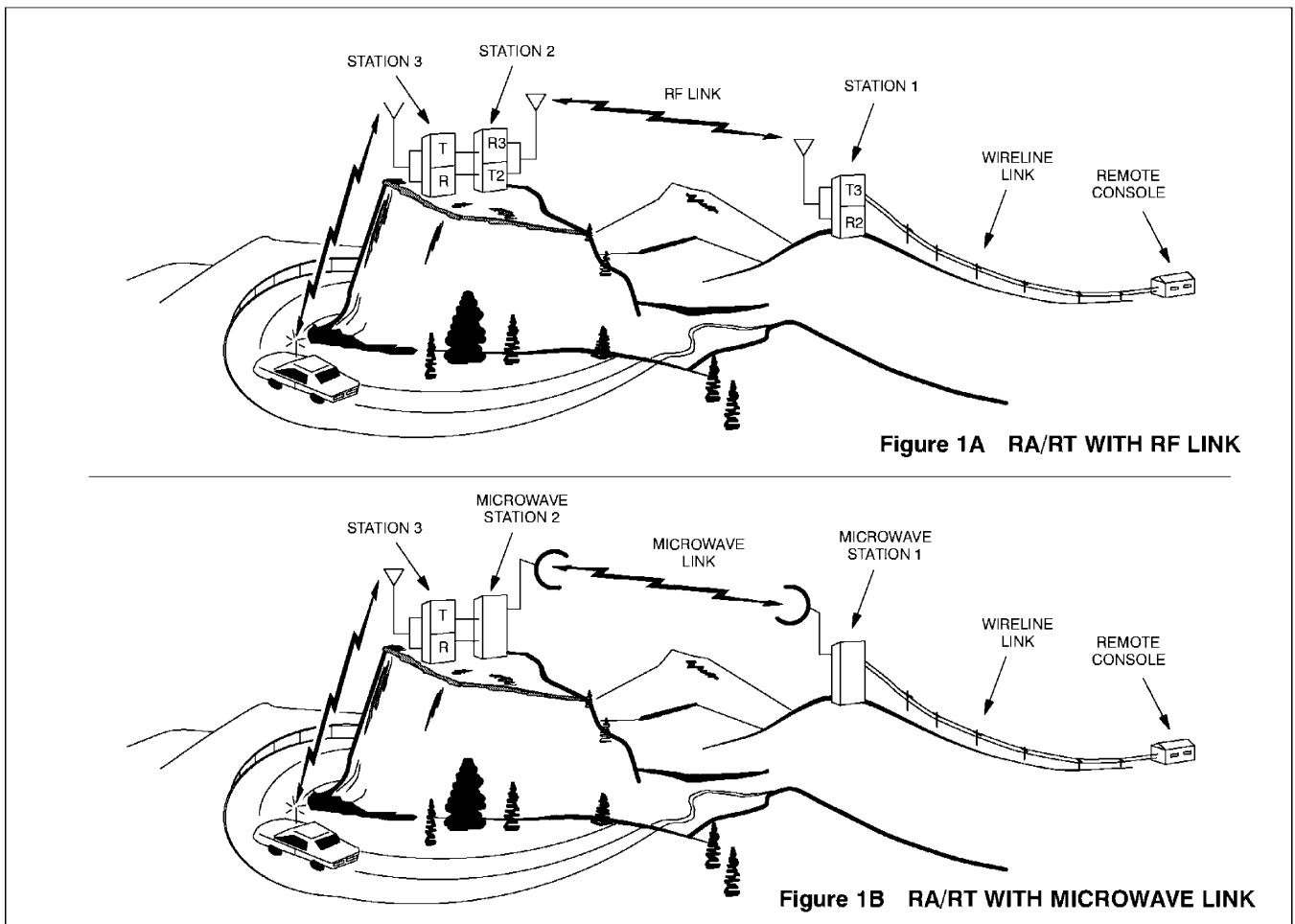

Figure 1. Typical RA/RT Systems (TRC Control)

## 2 ELECTRICAL CONNECTIONS (RF LINK)

Install stations 1, 2, and 3 as described in the appropriate functional base station manual. Figure 2 shows the connections between the stations necessary to allow RA/RT (TRC control) operation. Perform the following procedures to make the wiring connections between the console and Station 1 and between Stations 2 and 3.

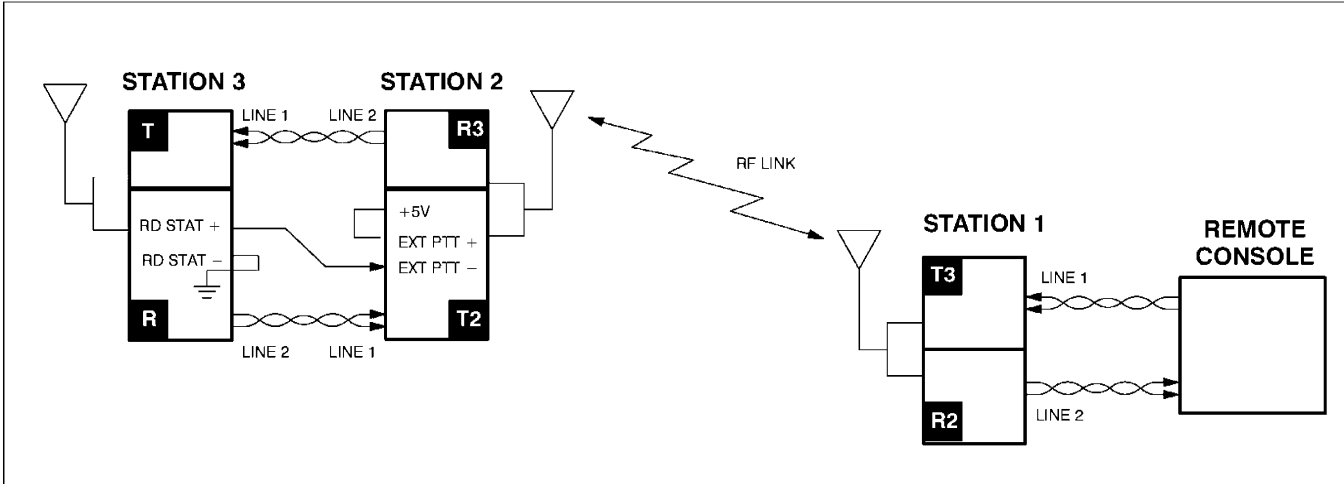
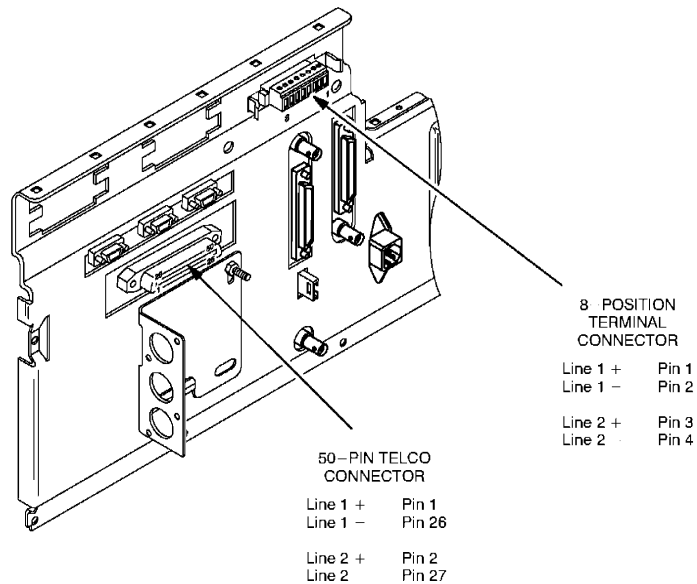

Figure 2. RA/RT (TRC Control) Wiring Connections (RF Link)

### Console to Station 1 Wiring Connections

- Step 1.** Connect the landline-to-station audio (from the console) to the Line 1 connections on the backplane of Station 1 as shown below.
- Step 2.** Connect the station-to-landline audio (to the console) to the Line 2 connections on the backplane of Station 1, as shown below.

**Note** Phoneline connections may be made at either the 50-pin Telco connector or the 8-position terminal connector. Refer to the **Installation** section of the appropriate station functional manual for more details on phone line connections.



## Station 2 to Station 3 Wiring Connections

**Note** Phone line connections may be made at either the 50-pin Telco connector or the 8-position terminal connector. Refer to the **Installation** section of the appropriate station functional manual for more details on phone line connections.

### Wireline Connections

- Step 1.** Connect the Line 1 audio from Station 2 to the Line 2 connections on Station 3 as shown below.
- Step 2.** Connect the Line 2 audio from Station 2 to the Line 1 connections on Station 3 as shown below.

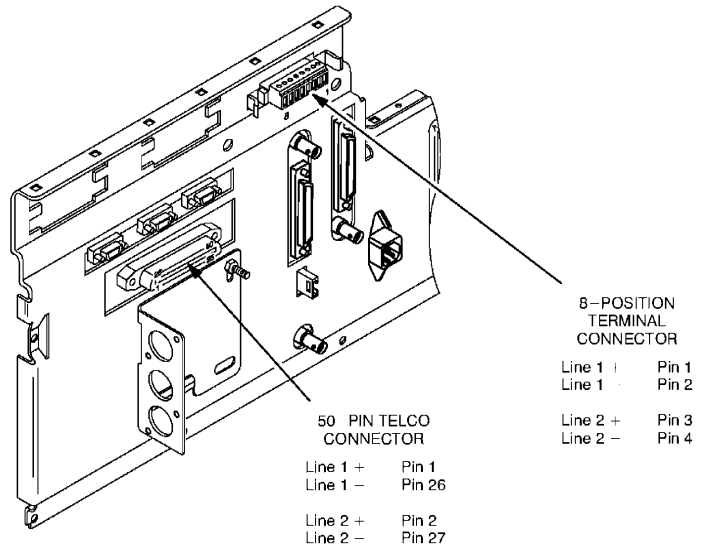

### RDSTAT to EXT PTT Connection

- Step 1.** Connect the RD STAT + and - signals from Station 3 to the EXT PTT + and - signals on Station 2 as shown below. An equivalent schematic circuit for the RD STAT and EXT PTT signals is also shown.

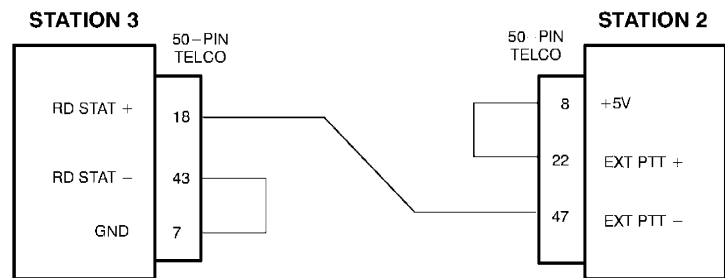

**Note** RDSTAT INT signal goes high when Station 3 detects receive signal (according to RX Activation parameter setting via RSS). This energizes relay, turns on LED in optocoupler, and pulls EXT PTT INT low. This causes Station 2 transmitter to key up and routes Line 1 audio to the transmitter.

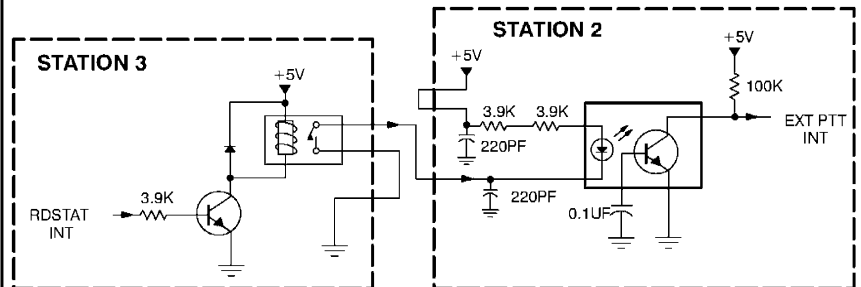

### 3 ELECTRICAL CONNECTIONS (MICROWAVE LINK)

Install the station as described in the appropriate functional base station manual. Figure 2 shows the connections between the station, microwave equipment, and console necessary to allow RA/RT (TRC control) operation. Perform the following procedures to make the wiring connections between the console and the Microwave Station 1 and between Microwave Station 2 and Station 3.

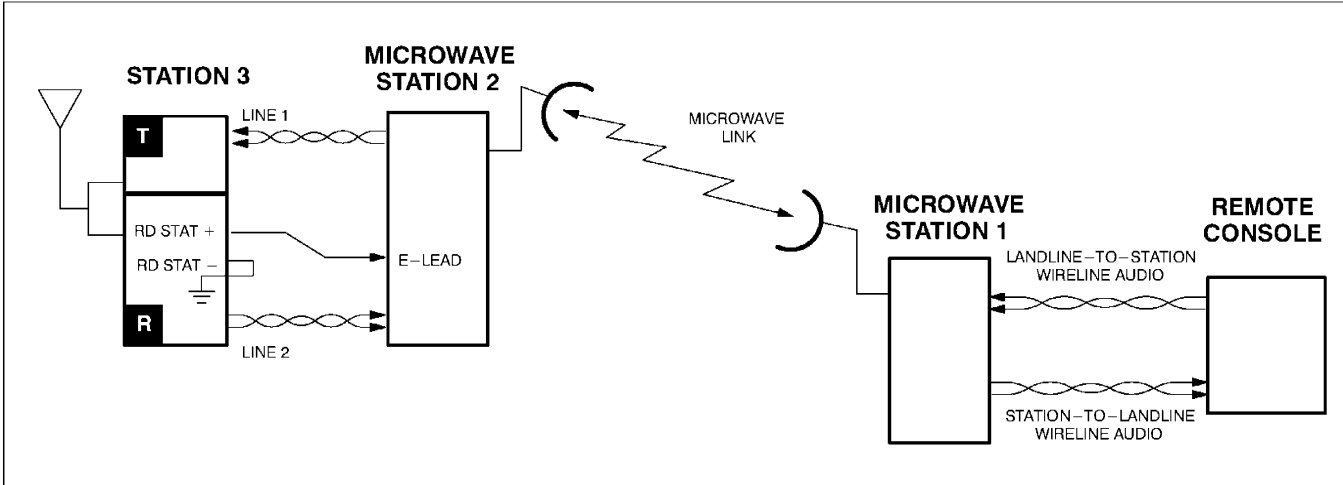

Figure 3. RA/RT (TRC Control) Wiring Connections (Microwave Link)

#### Console to Microwave Station 1 Wiring Connections

**Note** Refer to the Microwave Station manual for details of making wireline connections.

- Step 1.** Connect the landline-to-station audio (from the console) to Microwave Station 1.
- Step 2.** Connect the station-to-landline audio (to the console) to the Microwave Station.

## Microwave Station 2 to Station 3 Wiring Connections

**Note** Refer to the Microwave Station manual for details of making wireline connections.

**Note** Phone line connections may be made at either the 50-pin Telco connector or the 8-position terminal connector. Refer to the **Installation** section of the appropriate station functional manual for more details on phone line connections.

### Wireline Connections

- Step 1.** Connect the station-to-landline audio from Microwave Station 2 to the Line 1 connections on Station 3 as shown below.
- Step 2.** Connect the landline-to-station audio to Microwave Station 2 to the Line 2 connections on Station 3 as shown below.

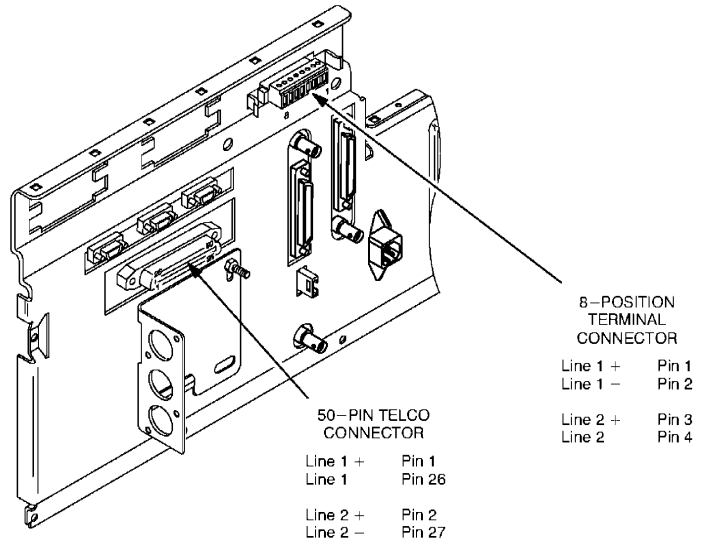

### RDSTAT to E-Lead Connection

- Step 1.** Connect the RD STAT + and - signals from Station 3 to the E-Lead signal on Microwave Station 2 as shown below. An equivalent schematic circuit for the RD STAT and E LEAD signals is also shown.

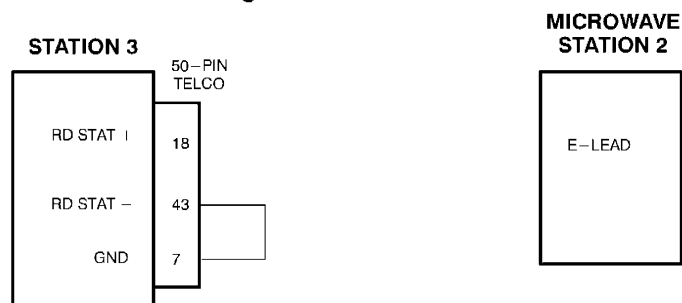

**Note** RDSTAT INT signal goes high when Station 3 detects receive signal (according to RX Activation parameter setting via RSS). This energizes relay and provides ground signal to E LEAD input on Microwave Station 2.

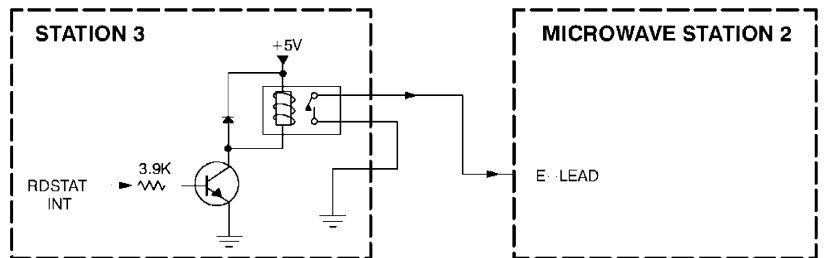

## 4 RSS PROGRAMMING

Using the *Quantar/Quantro* Radio Service Software (RSS) program, make the following codeplug data changes to allow proper RA/RT operation. (Refer to the *RSS User's Guide 68P81085E35* for details on making codeplug programming changes.)

**Table 1.** Codeplug Data Changes for RA/RT Operation (RF Link Configuration)

Equipment	Codeplug Data Parameter	RSS User's Guide Location
Station 1	Change command for Guard Tone from (typically) MORE to <b>KEY</b> . Leave all other commands empty.	Programming the TRC Commands Data (p/o Chapter 4)
	<b>Disable</b> TX Notch Filter	Programming the Wireline Configuration Data (p/o Chapter 4)
Station 3	<b>Enable</b> TX Notch Filter	Programming the Wireline Configuration Data (p/o Chapter 4)

**Note** — Make sure console is programmed for 240 msec HLG. On SECURENET systems, increase to 360 msec.

**Table 2.** Codeplug Data Changes for RA/RT Operation (Microwave Link Configuration)

Equipment	Codeplug Data Parameter	RSS User's Guide Location
Station 3	<b>Enable</b> TX Notch Filter	Programming the Wireline Configuration Data (p/o Chapter 4)

**Note** — Make sure console is programmed for 240 msec HLG. On SECURENET systems, increase to 360 msec.

## 5 TX WIRELINE ALIGNMENT

You may align the TX Wireline levels as described in the *RSS User's Guide 68P81085E35* (which requires the use of an external signal generator), or you may use the station to generate the alignment tone. This method is described as follows.

**Note** — Make sure the *Automatic Line Control* parameter is disabled for Stations 1, 2, and 3.

### Station 1 TX Wireline Alignment

Perform standard TX Wireline alignment procedure located in *RSS User's Guide 68P81085E35*.

### Station 2 TX Wireline Alignment

- Step 1.** Connect the RSS to Station 3 and access the RX Wireline Alignment screen.
- Step 2.** Set the RX wireline level and **Save** it. (Note that the wireline level is typically set to  $-6$  dBm.)
- Step 3.** Press **F2** to turn on the 1 kHz tone. **Do not** exit this screen.
- Step 4.** With the RSS program still running, disconnect the RSS cable from Station 3 and connect it to Station 2. Now exit the RX Alignment screen.
- Step 5.** Access the TX Wireline Alignment screen and press **F8** to save the alignment value. (Station 3 is providing the 1 kHz alignment tone.)
- Step 6.** Exit the TX Wireline Alignment screen.
- Step 7.** With the RSS program still running, disconnect the RSS cable from Station 2 and connect it to Station 3.
- Step 8.** Access the RX Wireline Alignment screen and turn off the 1 kHz tone.



---

## Station 3 TX Wireline Alignment

- Step 1.** Connect the RSS to Station 2 and access the RX Wireline Alignment screen.
- Step 2.** Set the RX wireline level and **Save** it. (Note that the wireline level is typically set to  $-6$  dBm.)
- Step 3.** Press **F2** to turn on the 1 kHz tone. **Do not** exit this screen.
- Step 4.** With the RSS program still running, disconnect the RSS cable from Station 2 and connect it to Station 3. Now exit the RX Alignment screen.
- Step 5.** Access the TX Wireline Alignment screen and press **F8** to save the alignment value. (Station 2 is providing the 1 kHz alignment tone.)
- Step 6.** Exit the TX Wireline Alignment screen.
- Step 7.** With the RSS program still running, disconnect the RSS cable from Station 3 and connect it to Station 2.
- Step 8.** Access the RX Wireline Alignment screen and turn off the 1 kHz tone.

# RA/RT CONFIGURATION (E & M KEYING)

For *Quantar* and *Quantro* Stations

## 1 OVERVIEW

The RA/RT (E & M keying) configuration allows a *Quantar/Quantro* station to be controlled by a remote console using either a radio link or a microwave link in place of the usual wireline link. This configuration is typically used in cases where the station is located in a relatively inaccessible location (such as a mountain top) where running phone lines is either impractical or impossible.

As shown in Figure 1A, a pair of stations (called station 1 and station 2) is used to substitute for the normal wireline connections between the repeater station and the console. Figure 1B shows a microwave RA/RT link.

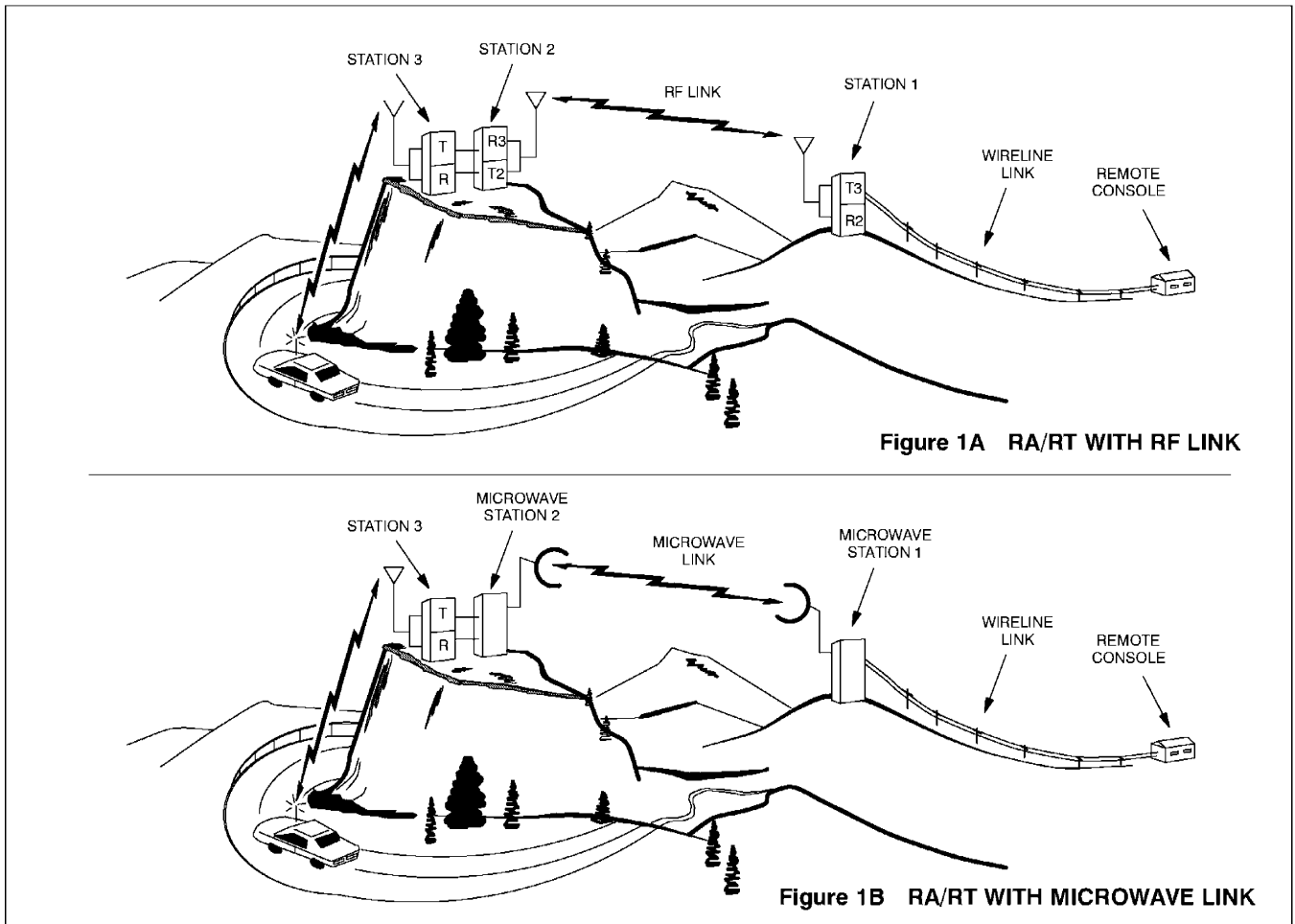

Figure 1. Typical RA/RT Systems (E & M Keying)

## 2 ELECTRICAL CONNECTIONS (RF LINK)

Install stations 1, 2, and 3 as described in the appropriate functional base station manual. Figure 2 shows the connections between the stations necessary to allow RA/RT (E & M keying) operation. Perform the following procedures to make the wiring connections between the console and Station 1 and between Stations 2 and 3.

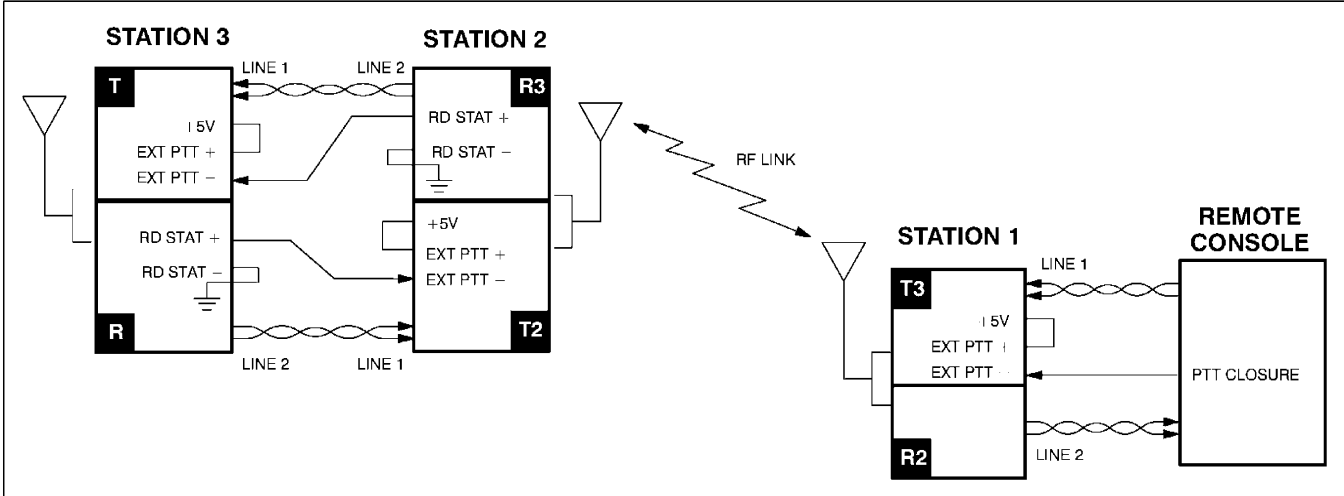
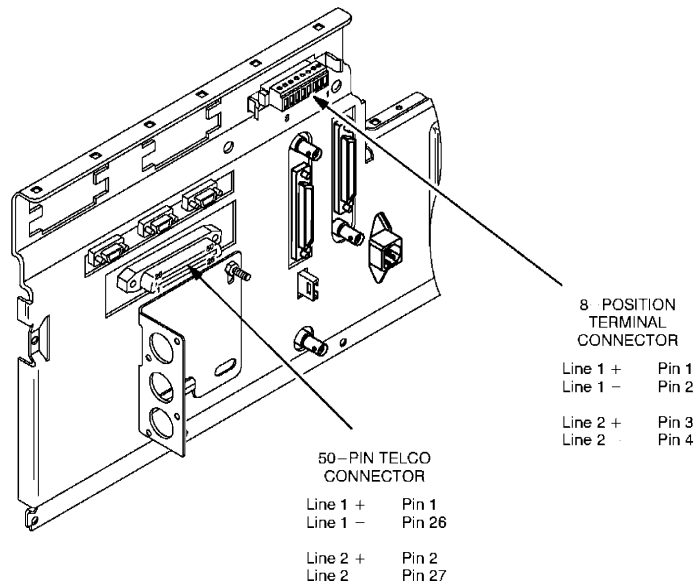

Figure 2. RA/RT (E & M Keying) Wiring Connections (RF Link)

### Console to Station 1 Wiring Connections

- Step 1.** Connect the landline-to-station audio (from the console) to the Line 1 connections on the backplane of Station 1 as shown below.
- Step 2.** Connect the station-to-landline audio (to the console) to the Line 2 connections on the backplane of Station 1, as shown below.

**Note** Phoneline connections may be made at either the 50-pin Telco connector or the 8-position terminal connector. Refer to the **Installation** section of the appropriate station functional manual for more details on phone line connections.



## Station 2 to Station 3 Wiring Connections

**Note** Phone line connections may be made at either the 50-pin Telco connector or the 8-position terminal connector. Refer to the **Installation** section of the appropriate station functional manual for more details on phone line connections.

### Wireline Connections

- Step 1.** Connect the Line 1 audio from Station 2 to the Line 2 connections on Station 3 as shown below.
- Step 2.** Connect the Line 2 audio from Station 2 to the Line 1 connections on Station 3 as shown below.

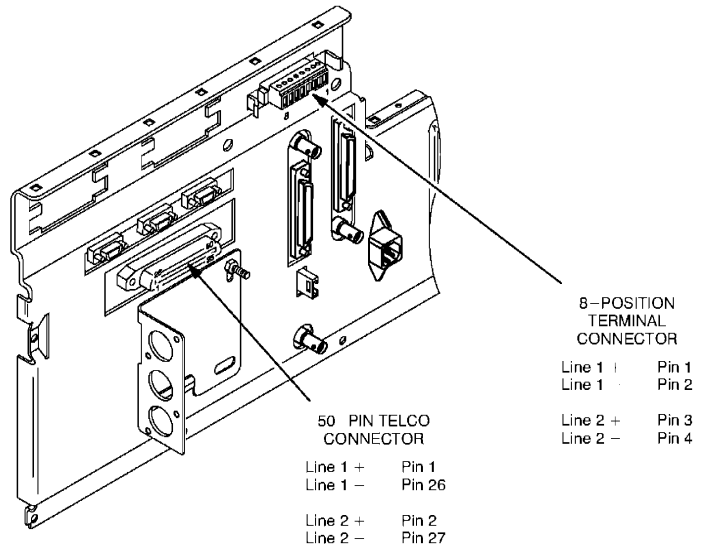

### RDSTAT to EXT PTT Connection (Station 3 to Station 2)

- Step 1.** Connect the RD STAT + and - signals from Station 3 to the EXT PTT + and - signals on Station 2 as shown below. An equivalent schematic circuit for the RD STAT and EXT PTT signals is also shown.

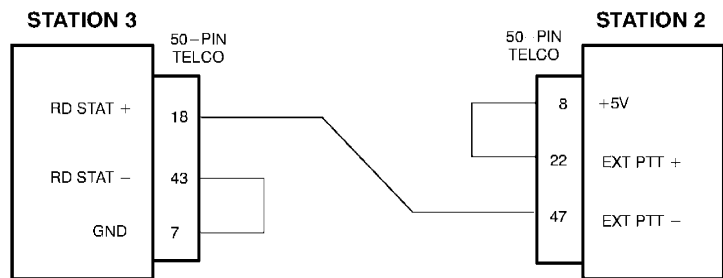

**Note** RDSTAT INT signal goes high when Station 3 detects receive signal (according to RX Activation parameter setting via RSS). This energizes relay, turns on LED in optocoupler, and pulls EXT PTT INT low. This causes Station 2 transmitter to key up and routes Line 1 audio to the transmitter.

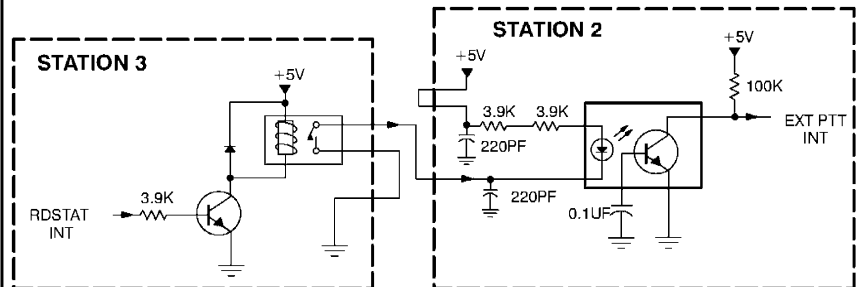

**Station 2 to Station 3  
Wiring Connections  
(Cont'd)**

**RDSTAT to EXT PTT Connection (Station 2 to Station 3)**

**Step 1.** Connect the RD STAT + and – signals from Station 2 to the EXT PTT + and – signals on Station 3 as shown below. An equivalent schematic circuit for the RD STAT and EXT PTT signals is also shown.

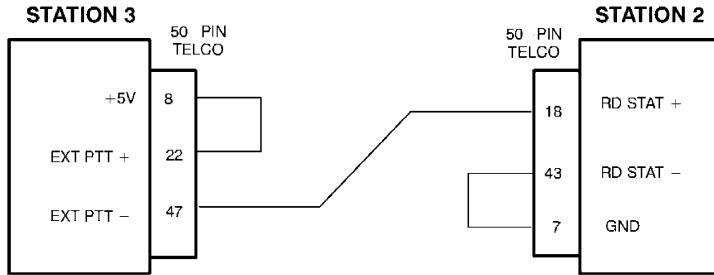

**Note** RDSTAT INT signal goes high when Station 2 detects receive signal (according to RX Activation parameter setting via RSS). This energizes relay, turns on LED in optocoupler, and pulls EXT PTT INT low. This causes Station 3 transmitter to key up and routes Line 1 audio to the transmitter.

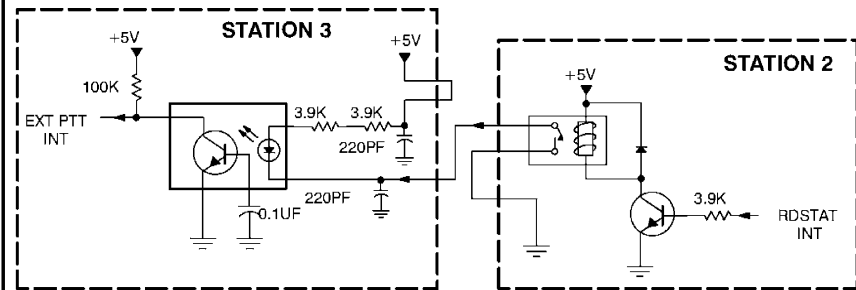

### 3 ELECTRICAL CONNECTIONS (MICROWAVE LINK)

Install the station as described in the appropriate functional base station manual. Figure 2 shows the connections between the station, microwave equipment, and console necessary to allow RA/RT (E & M keying) operation. Perform the following procedures to make the wiring connections between the console and the Microwave Station 1 and between Microwave Station 2 and Station 3.

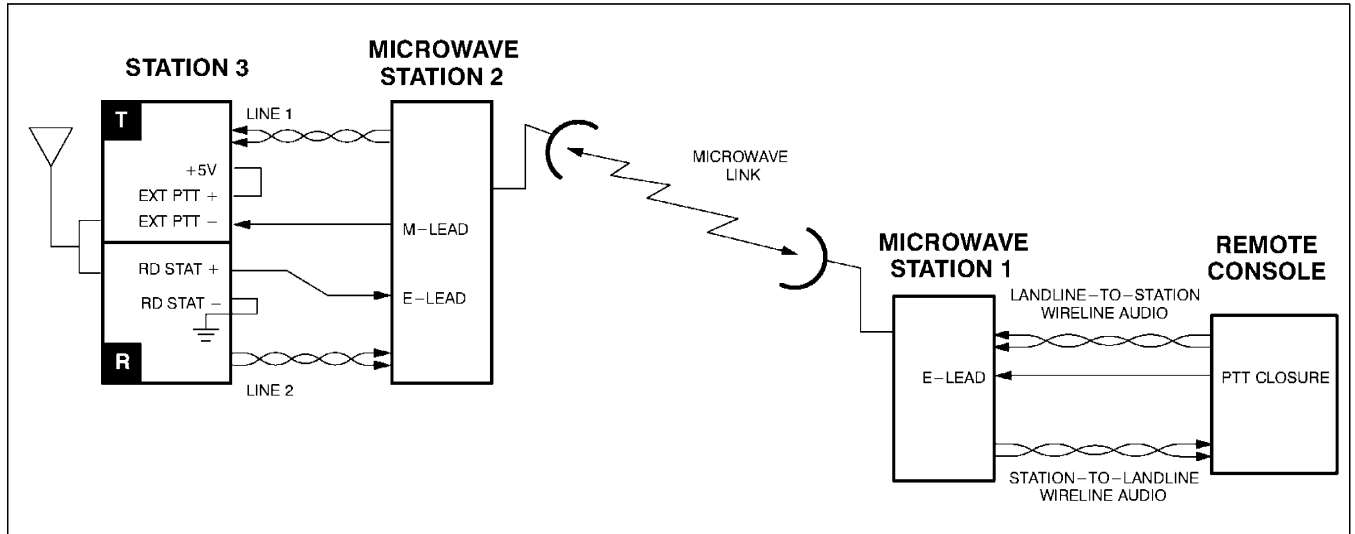

**Figure 3.** RA/RT (E & M Keying) Wiring Connections (Microwave Link)

#### Console to Microwave Station 1 Wiring Connections

**Note** Refer to the Microwave Station manual for details of making wireline connections.

- Step 1.** Connect the landline-to-station audio (from the console) to Microwave Station 1.
- Step 2.** Connect the station-to-landline audio (to the console) to the Microwave Station.

## Microwave Station 2 to Station 3 Wiring Connections

**Note** Refer to the Microwave Station manual for details of making wireline connections.

**Note** Phone line connections may be made at either the 50-pin Telco connector or the 8-position terminal connector. Refer to the **Installation** section of the appropriate station functional manual for more details on phone line connections.

### Wireline Connections

- Step 1.** Connect the station-to-landline audio from Microwave Station 2 to the Line 1 connections on Station 3 as shown below.
- Step 2.** Connect the landline-to-station audio to Microwave Station 2 to the Line 2 connections on Station 3 as shown below.

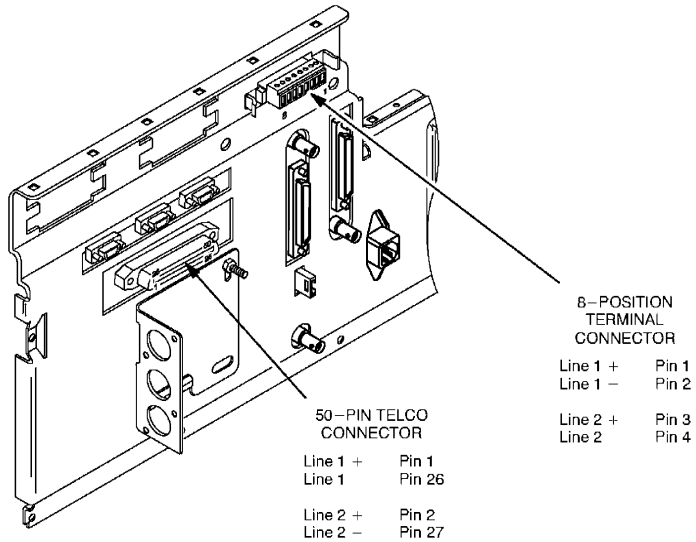

### RDSTAT to E-Lead Connection (Station 3 to Station 2)

- Step 1.** Connect the RD STAT + and - signals from Station 3 to the E-Lead signal on Microwave Station 2 as shown below. An equivalent schematic circuit for the RD STAT and E LEAD signals is also shown.

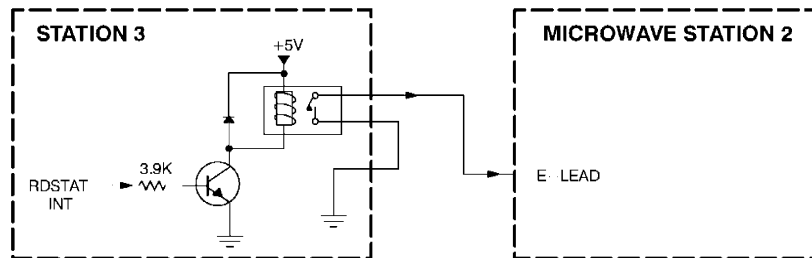
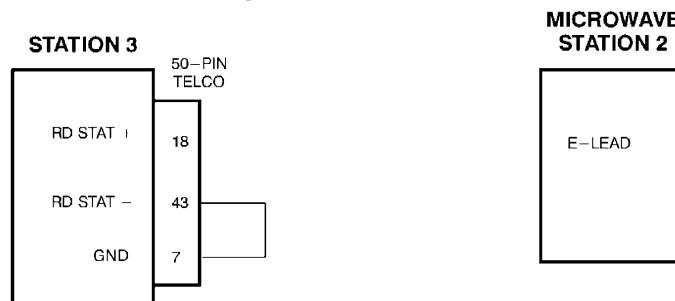

**Note** RDSTAT INT signal goes high when Station 3 detects receive signal (according to RX Activation parameter setting via RSS). This energizes relay and provides ground signal to E LEAD input on Microwave Station 2.

**Microwave Station 2 to Station 3 Wiring Connections (Cont'd)**

**M-Lead to EXT PTT Connection (Station 2 to Station 3)**

**Step 1.** Connect the M-Lead on the Microwave Station 2 to the EXT PTT + signal on Station 3 as shown below. An equivalent schematic circuit for the EXT PTT and M LEAD signals is also shown.

**Note** MLEAD output from Microwave Station 2 goes low when transmitting signal on wireline. This causes EXT PTT to activate and key Station 3 transmitter.

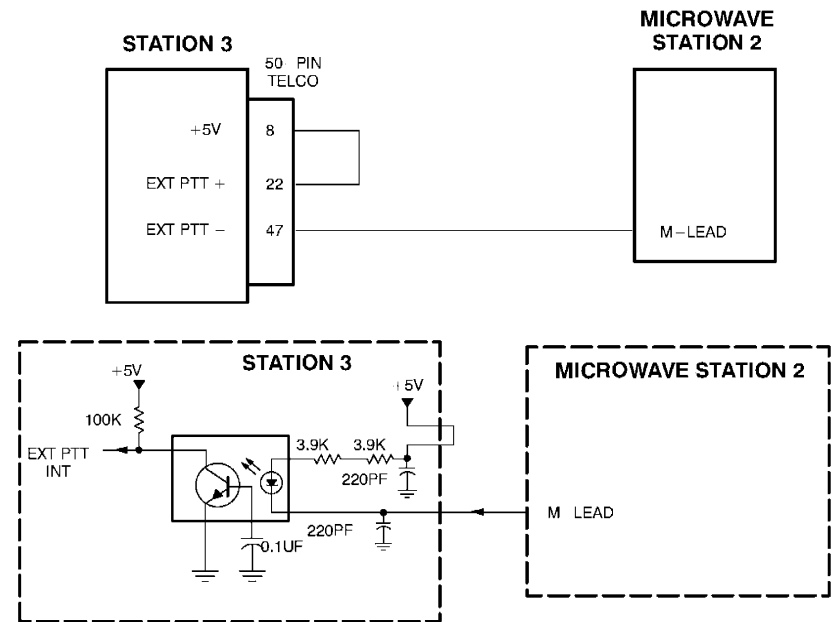



# 4 RSS PROGRAMMING

Using the *Quantar/Quantro* Radio Service Software (RSS) program, make the following codeplug data changes to allow proper RA/RT operation. (Refer to the *RSS User's Guide 68P81085E35* for details on making codeplug programming changes.)

**Table 1.** Codeplug Data Changes for RA/RT Operation (RF Link Configuration)

Equipment	Codeplug Data Parameter	RSS User's Guide Location
Station 1	<b>Disable</b> TX Notch Filter	Programming the Wireline Configuration Data (p/o Chapter 4)
Station 3	<b>Disable</b> TX Notch Filter	Programming the Wireline Configuration Data (p/o Chapter 4)

**Table 2.** Codeplug Data Changes for RA/RT Operation (Microwave Link Configuration)

Equipment	Codeplug Data Parameter	RSS User's Guide Location
Station 3	<b>Disable</b> TX Notch Filter	Programming the Wireline Configuration Data (p/o Chapter 4)

## 5 TX WIRELINE ALIGNMENT

You may align the TX Wireline levels as described in the *RSS User's Guide 68P81085E35* (which requires the use of an external signal generator), or you may use the station to generate the alignment tone. This method is described as follows.

**Note** — Make sure the *Automatic Line Control* parameter is disabled for Stations 1, 2, and 3.

---

### Station 1 TX Wireline Alignment

Perform standard TX Wireline alignment procedure located in *RSS User's Guide 68P81085E35*.

---

### Station 2 TX Wireline Alignment

- Step 1.** Connect the RSS to Station 3 and access the RX Wireline Alignment screen.
- Step 2.** Set the RX wireline level and **Save** it. (Note that the wireline level is typically set to  $-6$  dBm.)
- Step 3.** Press **F2** to turn on the 1 kHz tone. **Do not** exit this screen.
- Step 4.** With the RSS program still running, disconnect the RSS cable from Station 3 and connect it to Station 2. Now exit the RX Alignment screen.
- Step 5.** Access the TX Wireline Alignment screen and press **F8** to save the alignment value. (Station 3 is providing the 1 kHz alignment tone.)
- Step 6.** Exit the TX Wireline Alignment screen.
- Step 7.** With the RSS program still running, disconnect the RSS cable from Station 2 and connect it to Station 3.
- Step 8.** Access the RX Wireline Alignment screen and turn off the 1 kHz tone.

---

## Station 3 TX Wireline Alignment

- Step 1.** Connect the RSS to Station 2 and access the RX Wireline Alignment screen.
- Step 2.** Set the RX wireline level and **Save** it. (Note that the wireline level is typically set to  $-6$  dBm.)
- Step 3.** Press **F2** to turn on the 1 kHz tone. **Do not** exit this screen.
- Step 4.** With the RSS program still running, disconnect the RSS cable from Station 2 and connect it to Station 3. Now exit the RX Alignment screen.
- Step 5.** Access the TX Wireline Alignment screen and press **F8** to save the alignment value. (Station 2 is providing the 1 kHz alignment tone.)
- Step 6.** Exit the TX Wireline Alignment screen.
- Step 7.** With the RSS program still running, disconnect the RSS cable from Station 3 and connect it to Station 2.
- Step 8.** Access the RX Wireline Alignment screen and turn off the 1 kHz tone.

## 1 OVERVIEW

### **Feature Description**

The Fall Back In-Cabinet Repeat (FBICR) feature provides limited backup communications capabilities in Simulcast (Option U764) and Non-Simulcast Voting (Option X269) systems in which the link to the Comparator has been lost (phone line disruption, cable disconnection, etc.). Figure 1 and Figure 2 illustrate typical scenarios in which the FBICR mode is activated. (Note that in these examples automatic FBICR mode is assumed; refer to *Automatic and External Modes* below for details.)

**Note** The FBICR feature is supported only for Station/RSS Release R10.03.00 and later.

### **Automatic and External Modes**

The FBICR feature may be configured for either automatic or external modes (depending on system types, as explained later). Automatic mode is configured by programming certain station parameters using the Radio Service Software (RSS). External mode requires (in addition to RSS settings) that electrical connections be made to certain pins on the System Connector (Connector #17) located on the station backplane; external equipment (customer-provided) is used to ground one or more of these lines to force the station into FBICR mode.

The FBICR feature can be configured for the following system types in Automatic or External Modes:

#### **Automatic Mode**

- Conventional Analog (both Simulcast and Non-Simulcast Voting Systems)
- Conventional *ASTRO* (CAI) (both Simulcast and Non-Simulcast Voting Systems)
- Trunked *ASTRO* (SMARTZONE or SMARTNET) (CAI, VSELP) (Simulcast only)

#### **External Mode**

- Conventional Analog (both Simulcast and Non-Simulcast Voting Systems)
- Conventional *ASTRO* (CAI) (both Simulcast and Non-Simulcast Voting Systems)
- Trunked Analog (SMARTZONE or SMARTNET) (both Simulcast and Non-Simulcast Voting Systems)
- Trunked *ASTRO* (SMARTZONE or SMARTNET) (CAI, VSELP) (Simulcast only)

— continued on page 3 —

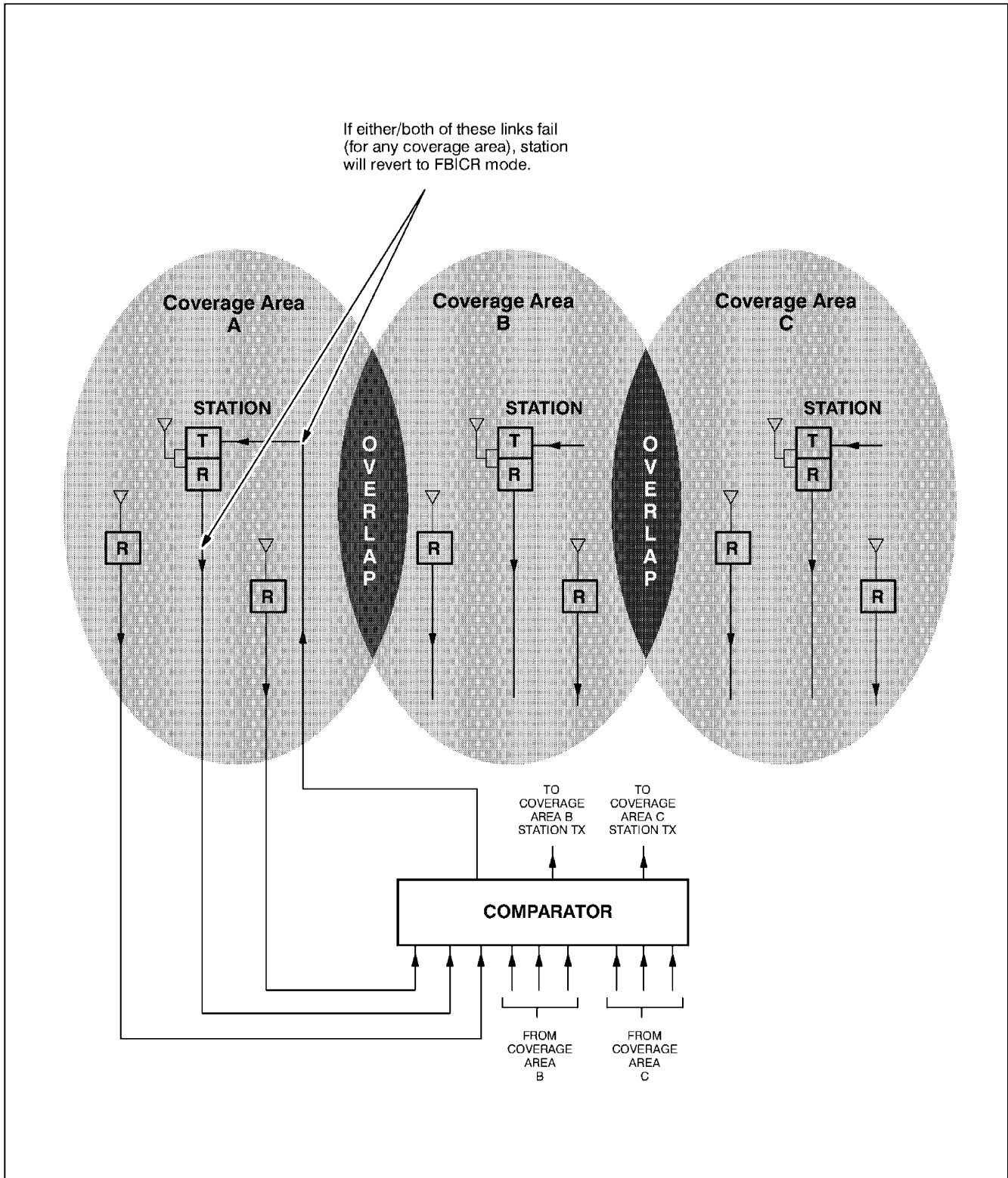

**Figure 1.** FBICR Feature in Simulcast Voting System (Automatic FBICR Mode Shown)

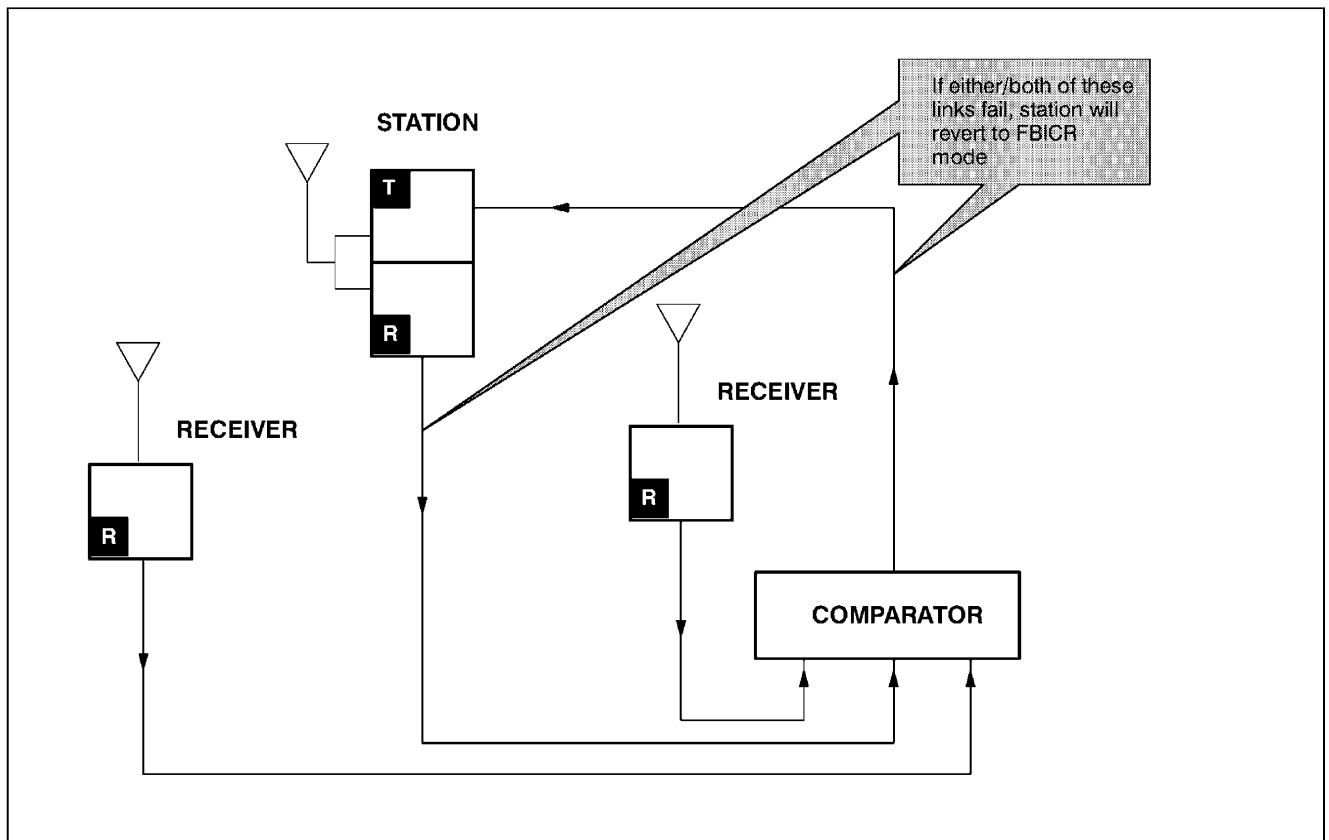

**Figure 2.** FBICR Feature in Non-Simulcast Voting System (Automatic FBICR Mode Shown)

### Link Failure Detection Requirements

Before automatically enabling FBICR mode, a link failure detection must occur, defined as follows:

#### For Digital Systems

- Protocol Failure
- Carrier Detect Loss

**Note** In a V.24 Hybrid Configuration, the loss of the analog link **will not** cause the station to enter FBICR mode. Only the failure of the digital link will cause the station to enter FBICR mode.

#### For Analog Systems

- Loss of External PTT (Simulcast)
- No TRC Keyup (Voting)

### Other Things to Know

- It is important to note that a station operating in FBICR mode is independent of other stations/receivers in the particular system. This is especially important in a Simulcast system, because simulcast transmission timing will be lost for the overlap coverage area between an active Simulcast station and a FBICR station. In a typical Simulcast scenario, the station responsible for the major coverage area is set for FBICR, and any adjacent stations are subsequently disabled.
- Automatic and External modes are mutually exclusive (i.e., a station may not be configured for both modes).

## 2 CONFIGURING THE FBICR FEATURE

Depending on the system type and whether you wish to configure for automatic or external operation, the FBICR feature must be configured by using the RSS only, or a combination of RSS programming and external wiring connections. Each configuration scenario is described on the following pages.

### Automatic Mode

#### Conventional Analog or Conventional ASTRO (CAI) (Simulcast or Non-Simulcast Voting Systems)

- Step 1.** Access the *Wireline Configuration Screen*.
- Step 2.** Set the *Fall Back In-Cabinet Repeat* field to **ENABLED**.
- Step 3.** Enter the desired delay time (in msec) in the *Fall Back Timer* field.

MOTOROLA RADIO SERVICE SOFTWARE BASE STATION PRODUCTS Page 1 of 2                      VER:XX.XX.XX :CHANGE/VIEW:WIRELINE CONFIGURATION	Use Up/Down Arrow Keys to Select Wireline Operation																																													
<table style="width: 100%; border-collapse: collapse;"> <tr> <td style="width: 45%;">Wireline Operation</td> <td style="width: 45%;">4 WIRE FULL DUPLEX</td> <td style="width: 10%;"></td> </tr> <tr> <td>Console Priority</td> <td>DISABLED</td> <td style="text-align: right;">OPTION</td> </tr> <tr> <td>Remote Control Type</td> <td>ASTRO</td> <td></td> </tr> <tr> <td>TRC Input</td> <td>Line 1</td> <td></td> </tr> <tr> <td>Outbound Analog Link Timer</td> <td>120 sec</td> <td></td> </tr> <tr> <td>Comparator</td> <td>NONE</td> <td style="text-align: right;">OPTION</td> </tr> <tr> <td>Fall Back In-Cabinet Repeat</td> <td>ENABLED</td> <td></td> </tr> <tr> <td>Fall Back Timer</td> <td>xxx msec</td> <td></td> </tr> <tr> <td colspan="3"> </td> </tr> <tr> <td>Status Tone</td> <td>ENABLED</td> <td></td> </tr> <tr> <td>Status Tone Frequency</td> <td>2175 kHz</td> <td></td> </tr> <tr> <td>Wireline Squelch</td> <td>DISABLED</td> <td></td> </tr> <tr> <td colspan="3"> </td> </tr> <tr> <td>Rx Securenet/ASTRO To Wireline</td> <td>ENABLED</td> <td></td> </tr> <tr> <td>Equalization</td> <td>DISABLED</td> <td></td> </tr> </table>	Wireline Operation	4 WIRE FULL DUPLEX		Console Priority	DISABLED	OPTION	Remote Control Type	ASTRO		TRC Input	Line 1		Outbound Analog Link Timer	120 sec		Comparator	NONE	OPTION	Fall Back In-Cabinet Repeat	ENABLED		Fall Back Timer	xxx msec					Status Tone	ENABLED		Status Tone Frequency	2175 kHz		Wireline Squelch	DISABLED					Rx Securenet/ASTRO To Wireline	ENABLED		Equalization	DISABLED		
Wireline Operation	4 WIRE FULL DUPLEX																																													
Console Priority	DISABLED	OPTION																																												
Remote Control Type	ASTRO																																													
TRC Input	Line 1																																													
Outbound Analog Link Timer	120 sec																																													
Comparator	NONE	OPTION																																												
Fall Back In-Cabinet Repeat	ENABLED																																													
Fall Back Timer	xxx msec																																													
Status Tone	ENABLED																																													
Status Tone Frequency	2175 kHz																																													
Wireline Squelch	DISABLED																																													
Rx Securenet/ASTRO To Wireline	ENABLED																																													
Equalization	DISABLED																																													
<table style="width: 100%; border-collapse: collapse;"> <tr> <td style="width: 10%;">F1</td> <td style="width: 10%;">F2</td> <td style="width: 10%;">F3</td> <td style="width: 10%;">F4</td> <td style="width: 10%;">F5</td> <td style="width: 10%;">F6</td> <td style="width: 10%;">F7</td> <td style="width: 10%;">F8</td> <td style="width: 10%;">F9</td> <td style="width: 10%;">F10</td> </tr> <tr> <td>HELP</td> <td></td> <td></td> <td></td> <td></td> <td></td> <td></td> <td></td> <td></td> <td>EXIT</td> </tr> </table>			F1	F2	F3	F4	F5	F6	F7	F8	F9	F10	HELP									EXIT																								
F1	F2	F3	F4	F5	F6	F7	F8	F9	F10																																					
HELP									EXIT																																					

◆ End of Procedure ◆

**Automatic Mode (continued)**

**Trunked (SMARTZONE or SMARTNET) ASTRO (CAI, VSELP)  
(Simulcast Systems Only)**

- Step 1.** Access the *Wireline Configuration Screen*.
- Step 2.** Set the *Fall Back In-Cabinet Repeat* field to **ENABLED**.  
(No *Fall Back Timer* setting is required.)

**Note** While in FBICR mode, the station will transmit Failsoft beeps and the subscriber will give the Failsoft indication.

MOTOROLA RADIO SERVICE SOFTWARE BASE STATION PRODUCTS Page 1 of 2                    VER:XX.XX.XX :CHANGE/VIEW:WIRELINE CONFIGURATION	Use Up/Down Arrow Keys to Select Wireline Operation																																							
<table style="width: 100%; border-collapse: collapse;"> <tr> <td style="width: 50%;">Wireline Operation</td> <td style="width: 30%;">4 WIRE FULL DUPLEX</td> <td style="width: 20%;"></td> </tr> <tr> <td>Console Priority</td> <td>DISABLED</td> <td style="text-align: right;">OPTION</td> </tr> <tr> <td>Remote Control Type</td> <td>ASTRO</td> <td></td> </tr> <tr> <td>TRC Input</td> <td>Line 1</td> <td></td> </tr> <tr> <td>Outbound Analog Link Timer</td> <td>120 sec</td> <td></td> </tr> <tr> <td>Comparator</td> <td>NONE</td> <td style="text-align: right;">OPTION</td> </tr> <tr> <td><b>Fall Back In-Cabinet Repeat</b></td> <td><b>ENABLED</b></td> <td></td> </tr> <tr> <td colspan="3"> </td> </tr> <tr> <td>Status Tone</td> <td>ENABLED</td> <td></td> </tr> <tr> <td>Status Tone Frequency</td> <td>2175 kHz</td> <td></td> </tr> <tr> <td>Wireline Squelch</td> <td>DISABLED</td> <td></td> </tr> <tr> <td colspan="3"> </td> </tr> <tr> <td>Rx Securenet/ASTRO To Wireline Equalization</td> <td>ENABLED DISABLED</td> <td></td> </tr> </table>	Wireline Operation	4 WIRE FULL DUPLEX		Console Priority	DISABLED	OPTION	Remote Control Type	ASTRO		TRC Input	Line 1		Outbound Analog Link Timer	120 sec		Comparator	NONE	OPTION	<b>Fall Back In-Cabinet Repeat</b>	<b>ENABLED</b>					Status Tone	ENABLED		Status Tone Frequency	2175 kHz		Wireline Squelch	DISABLED					Rx Securenet/ASTRO To Wireline Equalization	ENABLED DISABLED		
Wireline Operation	4 WIRE FULL DUPLEX																																							
Console Priority	DISABLED	OPTION																																						
Remote Control Type	ASTRO																																							
TRC Input	Line 1																																							
Outbound Analog Link Timer	120 sec																																							
Comparator	NONE	OPTION																																						
<b>Fall Back In-Cabinet Repeat</b>	<b>ENABLED</b>																																							
Status Tone	ENABLED																																							
Status Tone Frequency	2175 kHz																																							
Wireline Squelch	DISABLED																																							
Rx Securenet/ASTRO To Wireline Equalization	ENABLED DISABLED																																							
F1 HELP	F2	F3	F4	F5	F6	F7	F8	F9	F10 EXIT																															

- Step 3.** Access the *6809 Trunking Interface Screen*.
- Step 4.** Make sure the *Failsoft* field is set to **ENABLED**, and set the *Modulation Type* to **ASTRO** or **ANALOG**.

MOTOROLA RADIO SERVICE SOFTWARE BASE STATION PRODUCTS VER:XX.XX.XX :CHANGE/VIEW:6809 TRUNKING	Use Up/Dn Arrow Keys To Select RSTAT Mode																						
<table style="width: 100%; border-collapse: collapse;"> <tr> <td style="width: 50%;">RSTAT Mode</td> <td style="width: 50%;">Normal</td> </tr> <tr> <td><b>Failsoft</b></td> <td><b>ENABLED</b></td> </tr> <tr> <td>Line TRC Encode</td> <td>DISABLED</td> </tr> <tr> <td>Failsoft Carrier Squelch</td> <td>DISABLED</td> </tr> <tr> <td>Dual CT Failsoft Only</td> <td>DISABLED</td> </tr> <tr> <td><b>Modulation Type</b></td> <td><b>ASTRO</b></td> </tr> <tr> <td colspan="2"> </td> </tr> <tr> <td>Trunking Tickle Source</td> <td>TX DATA LINE</td> </tr> <tr> <td>Trunking Tickle Source TOT</td> <td>1 sec</td> </tr> <tr> <td>CSC Logical Channel Number</td> <td>1</td> </tr> <tr> <td>Rx Discriminator Type</td> <td>QUANTAR/MICOR</td> </tr> </table>	RSTAT Mode	Normal	<b>Failsoft</b>	<b>ENABLED</b>	Line TRC Encode	DISABLED	Failsoft Carrier Squelch	DISABLED	Dual CT Failsoft Only	DISABLED	<b>Modulation Type</b>	<b>ASTRO</b>			Trunking Tickle Source	TX DATA LINE	Trunking Tickle Source TOT	1 sec	CSC Logical Channel Number	1	Rx Discriminator Type	QUANTAR/MICOR	
RSTAT Mode	Normal																						
<b>Failsoft</b>	<b>ENABLED</b>																						
Line TRC Encode	DISABLED																						
Failsoft Carrier Squelch	DISABLED																						
Dual CT Failsoft Only	DISABLED																						
<b>Modulation Type</b>	<b>ASTRO</b>																						
Trunking Tickle Source	TX DATA LINE																						
Trunking Tickle Source TOT	1 sec																						
CSC Logical Channel Number	1																						
Rx Discriminator Type	QUANTAR/MICOR																						
F1 HELP	F2	F3	F4	F5	F6	F7	F8	F9	F10 EXIT														

◆ End of Procedure ◆





**External Mode (continued)**

**Trunked (SMARTZONE or SMARTNET) Analog  
(Simulcast or Non-Simulcast Voting Systems)**

- Step 1.** Access the *Wireline Configuration Screen*.
- Step 2.** Set the *Fall Back In-Cabinet Repeat* field to **ENABLED**.  
Set the *Fall Back In-Cabinet Repeat* field to **0 msec**.

MOTOROLA RADIO SERVICE SOFTWARE BASE STATION PRODUCTS Page 1 of 2                      VER:XX.XX.XX :CHANGE/VIEW:WIRELINE CONFIGURATION	Use Up/Down Arrow Keys to Select Wireline Operation																																							
<table style="width: 100%; border-collapse: collapse;"> <tr> <td style="width: 50%;">Wireline Operation</td> <td style="width: 30%;">4 WIRE FULL DUPLEX</td> <td style="width: 20%;"></td> </tr> <tr> <td>Console Priority</td> <td>DISABLED</td> <td style="text-align: right;">OPTION</td> </tr> <tr> <td>Remote Control Type</td> <td>ASTRO</td> <td></td> </tr> <tr> <td>TRC Input</td> <td>Line 1</td> <td></td> </tr> <tr> <td>Outbound Analog Link Timer</td> <td>120 sec</td> <td></td> </tr> <tr> <td>Comparator</td> <td>NONE</td> <td style="text-align: right;">OPTION</td> </tr> <tr> <td><b>Fall Back In-Cabinet Repeat</b></td> <td><b>ENABLED</b></td> <td></td> </tr> <tr> <td>Fall Back Timer</td> <td>0 msec</td> <td></td> </tr> <tr> <td>Status Tone</td> <td>ENABLED</td> <td></td> </tr> <tr> <td>Status Tone Frequency</td> <td>2175 kHz</td> <td></td> </tr> <tr> <td>Wireline Squelch</td> <td>DISABLED</td> <td></td> </tr> <tr> <td> </td> <td></td> <td></td> </tr> <tr> <td>Rx Securenet/ASTRO To Wireline Equalization</td> <td>ENABLED DISABLED</td> <td></td> </tr> </table>	Wireline Operation	4 WIRE FULL DUPLEX		Console Priority	DISABLED	OPTION	Remote Control Type	ASTRO		TRC Input	Line 1		Outbound Analog Link Timer	120 sec		Comparator	NONE	OPTION	<b>Fall Back In-Cabinet Repeat</b>	<b>ENABLED</b>		Fall Back Timer	0 msec		Status Tone	ENABLED		Status Tone Frequency	2175 kHz		Wireline Squelch	DISABLED		 			Rx Securenet/ASTRO To Wireline Equalization	ENABLED DISABLED		
Wireline Operation	4 WIRE FULL DUPLEX																																							
Console Priority	DISABLED	OPTION																																						
Remote Control Type	ASTRO																																							
TRC Input	Line 1																																							
Outbound Analog Link Timer	120 sec																																							
Comparator	NONE	OPTION																																						
<b>Fall Back In-Cabinet Repeat</b>	<b>ENABLED</b>																																							
Fall Back Timer	0 msec																																							
Status Tone	ENABLED																																							
Status Tone Frequency	2175 kHz																																							
Wireline Squelch	DISABLED																																							
Rx Securenet/ASTRO To Wireline Equalization	ENABLED DISABLED																																							
F1 HELP	F2	F3	F4	F5	F6	F7	F8	F9	F10 EXIT																															

- Step 3.** Access the *6809 Trunking Interface Screen*.
- Step 4.** Set the *Modulation Type* to **ANALOG**.

MOTOROLA RADIO SERVICE SOFTWARE BASE STATION PRODUCTS VER:XX.XX.XX :CHANGE/VIEW:6809 TRUNKING	Use Up/Dn Arrow Keys To Select RSTAT Mode																				
<table style="width: 100%; border-collapse: collapse;"> <tr> <td style="width: 50%;">RSTAT Mode</td> <td style="width: 50%;">Normal</td> </tr> <tr> <td>Failsoft</td> <td>DISABLED</td> </tr> <tr> <td>Line TRC Encode</td> <td>DISABLED</td> </tr> <tr> <td>Failsoft Carrier Squelch</td> <td>DISABLED</td> </tr> <tr> <td>Dual CT Failsoft Only</td> <td>DISABLED</td> </tr> <tr> <td><b>Modulation Type</b></td> <td><b>ANALOG</b></td> </tr> <tr> <td>Trunking Tickle Source</td> <td>TX DATA LINE</td> </tr> <tr> <td>Trunking Tickle Source TOT</td> <td>1 sec</td> </tr> <tr> <td>CSC Logical Channel Number</td> <td>1</td> </tr> <tr> <td>Rx Discriminator Type</td> <td>QUANTAR/MICOR</td> </tr> </table>	RSTAT Mode	Normal	Failsoft	DISABLED	Line TRC Encode	DISABLED	Failsoft Carrier Squelch	DISABLED	Dual CT Failsoft Only	DISABLED	<b>Modulation Type</b>	<b>ANALOG</b>	Trunking Tickle Source	TX DATA LINE	Trunking Tickle Source TOT	1 sec	CSC Logical Channel Number	1	Rx Discriminator Type	QUANTAR/MICOR	
RSTAT Mode	Normal																				
Failsoft	DISABLED																				
Line TRC Encode	DISABLED																				
Failsoft Carrier Squelch	DISABLED																				
Dual CT Failsoft Only	DISABLED																				
<b>Modulation Type</b>	<b>ANALOG</b>																				
Trunking Tickle Source	TX DATA LINE																				
Trunking Tickle Source TOT	1 sec																				
CSC Logical Channel Number	1																				
Rx Discriminator Type	QUANTAR/MICOR																				
F1 HELP	F2	F3	F4	F5	F6	F7	F8	F9	F10 EXIT												

— continued on next page —

## External Mode (continued)

### Trunked (SMARTZONE or SMARTNET) Analog (continued)

- Step 5.** Connect a wire to pin 11 and pin 16 of System Connector #17 (located on the station backplane). To activate FBICR mode, an external circuit (customer-provided) must ground these pins.

**Note** When pins 11 and 16 are grounded, the station will enter FBICR operation. The station will ignore any wireline transmit activity, ignore the EXT PTT line, and assert the TSTAT line. While in FBICR mode, the station will transmit Failsoft beeps and the subscriber will give the Failsoft indication.

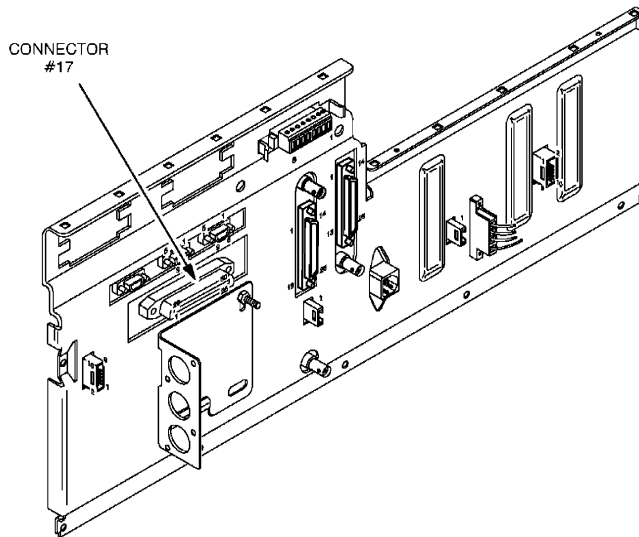

◆ End of Procedure ◆



**External Mode  
(continued)**

**Trunked (SMARTZONE or SMARTNET) ASTRO (CAI, VSELP)  
(continued)**

- Step 5.** Connect a wire to pin 11 and pin 16 of System Connector #17 (located on the station backplane). To activate FBICR mode, an external circuit (customer-provided) must ground these pins.

**Note** When pins 11 and 16 are grounded, the station will enter FBICR operation. The station will ignore any wireline transmit activity, ignore the EXT PTT line, and assert the TSTAT line. While in FBICR mode, the station will transmit Failsoft beeps and the subscriber will give the Failsoft indication.

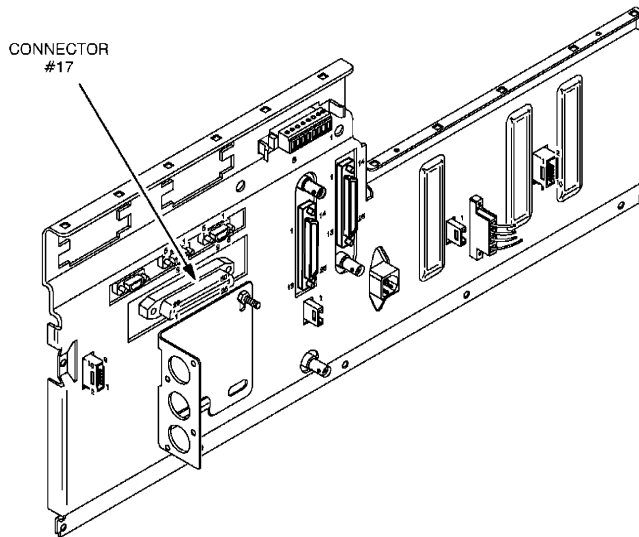

◆ End of Procedure ◆



# MAIN/STANDBY CONFIGURATION

For *Quantar* and *Quantro* Stations

---

---

## 1 OVERVIEW

The Main/Standby configuration allows two *Quantar/Quantro* stations to operate as a redundant pair. If the Main station should fail (due to hardware or software malfunction), the Standby station will immediately take over and provide service. Each station's operating mode (Main or Standby) is determined by a setting made using the Radio Service Software (RSS).

Please note the following requirements/restrictions that are applicable to the Main/Standby feature:

- Main/Standby feature is compatible with stations in **Conventional** systems only
- Main/Standby feature **is not** compatible with *ASTRO* signaling
- The station must be equipped with an 8-wire Wireline Interface Module and the Enhanced Wildcard Option

## 2 ELECTRICAL CONNECTIONS

Install both stations (designating one as A and the other as B) as described in the appropriate functional base station manual. Make the wiring connections as shown in Figure 2 to allow Main/Standby operation.

**Hint** *Wiring connections between the two stations and with external equipment will be facilitated by using a standard telephone punch block. Figure 1 shows how to connect the stations and punch block.*

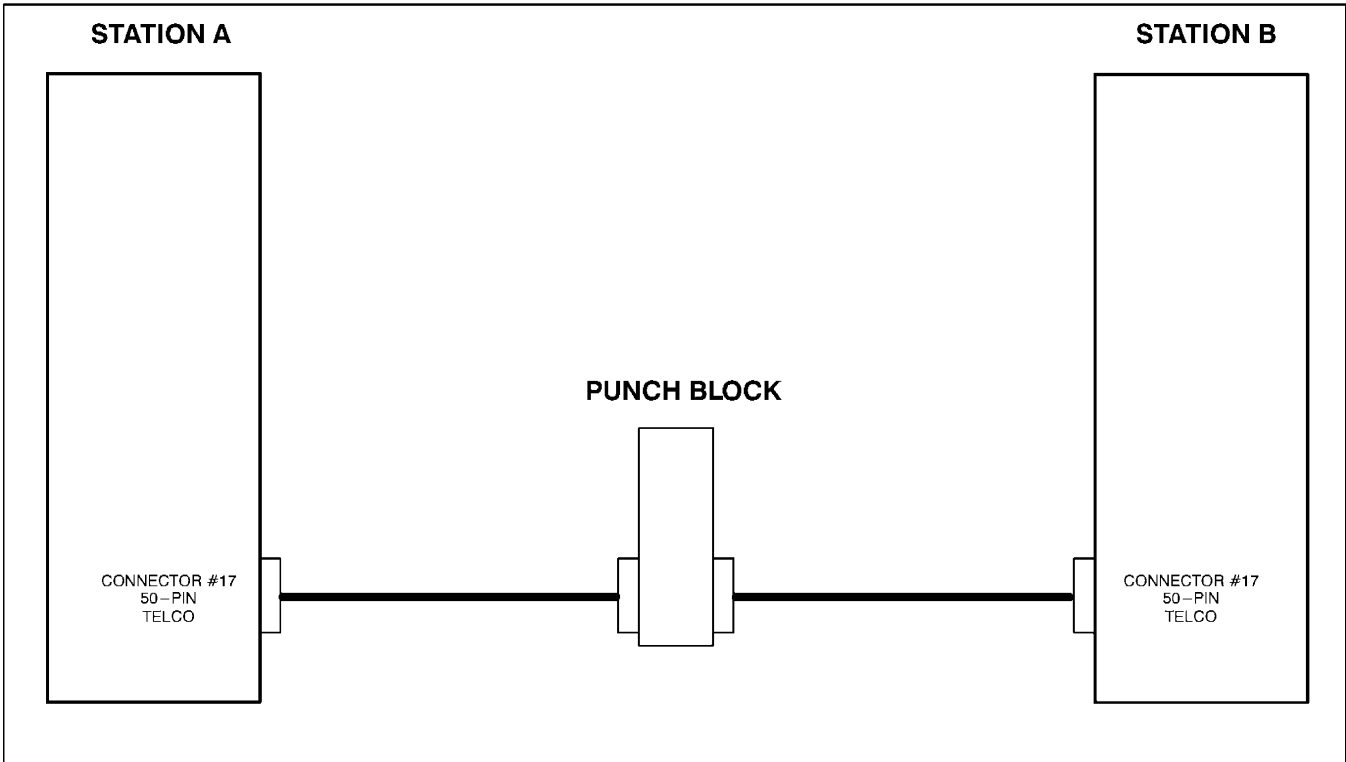

**Figure 1.** Using Punch Block to Facilitate Wiring Connections

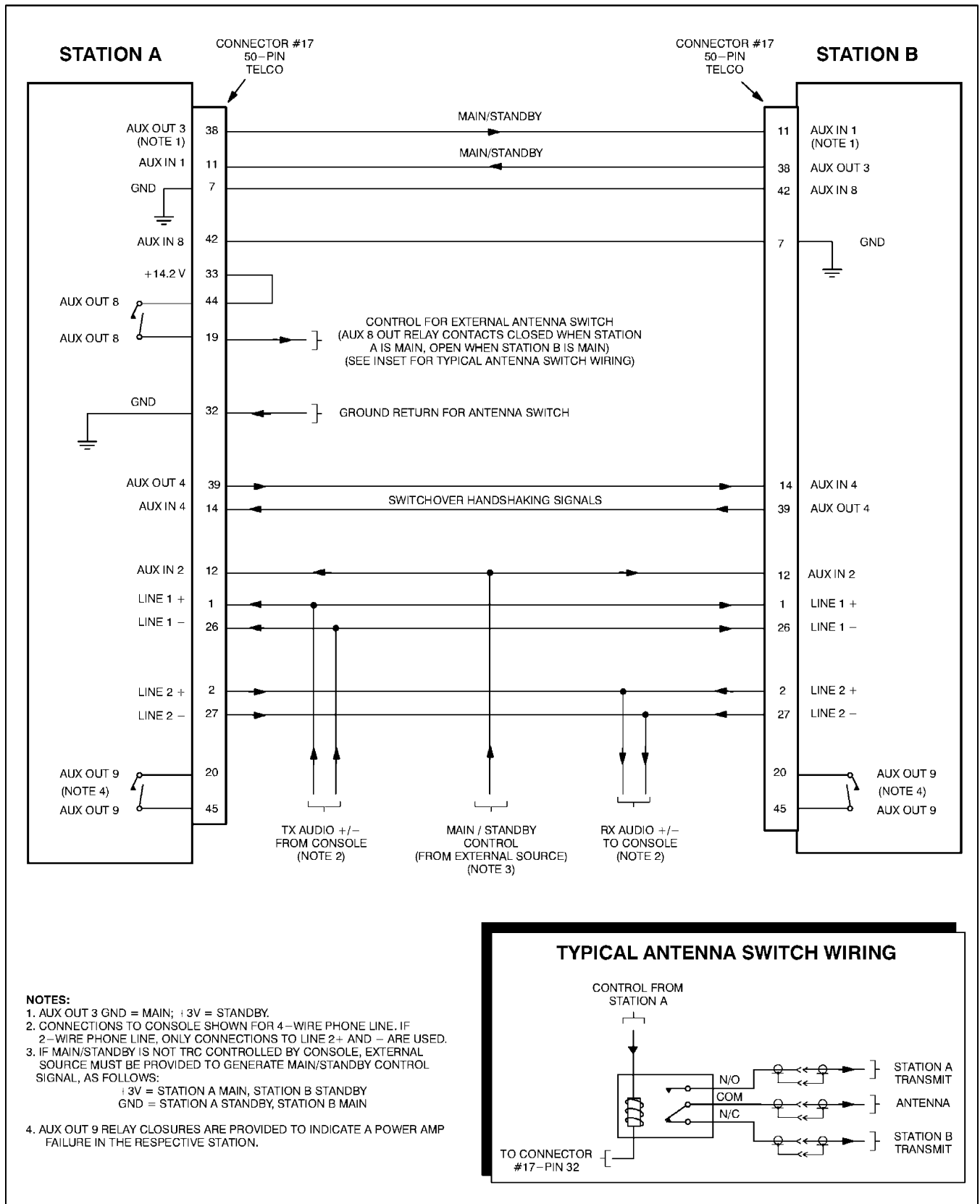

Figure 2. Wiring Connections for Main/Standby Configuration



### 3 SETTING WIRELINE IMPEDANCE JUMPERS

Set the impedance jumpers on the Wireline Interface Modules in Stations A and B as described in Table 1. Figure 3 shows the location of the jumpers.

**Table 1.** Wireline Impedance Jumpering for Main/Standby Operation

STATION A		STATION B	
2-Wire Connection to Console	4-Wire Connection to Console	2-Wire Connection to Console	4-Wire Connection to Console
Jumpers in position 1 on T1001	Jumpers in position 1 on T1000 and T1001	All jumpers removed (high impedance) on T1001	All jumpers removed (high impedance) on T1000 and T1001
Jumper JU1010 in 2-wire position	Jumper JU1010 in 4-wire position	Jumper JU1010 in 2-wire position	Jumper JU1010 in 4-wire position

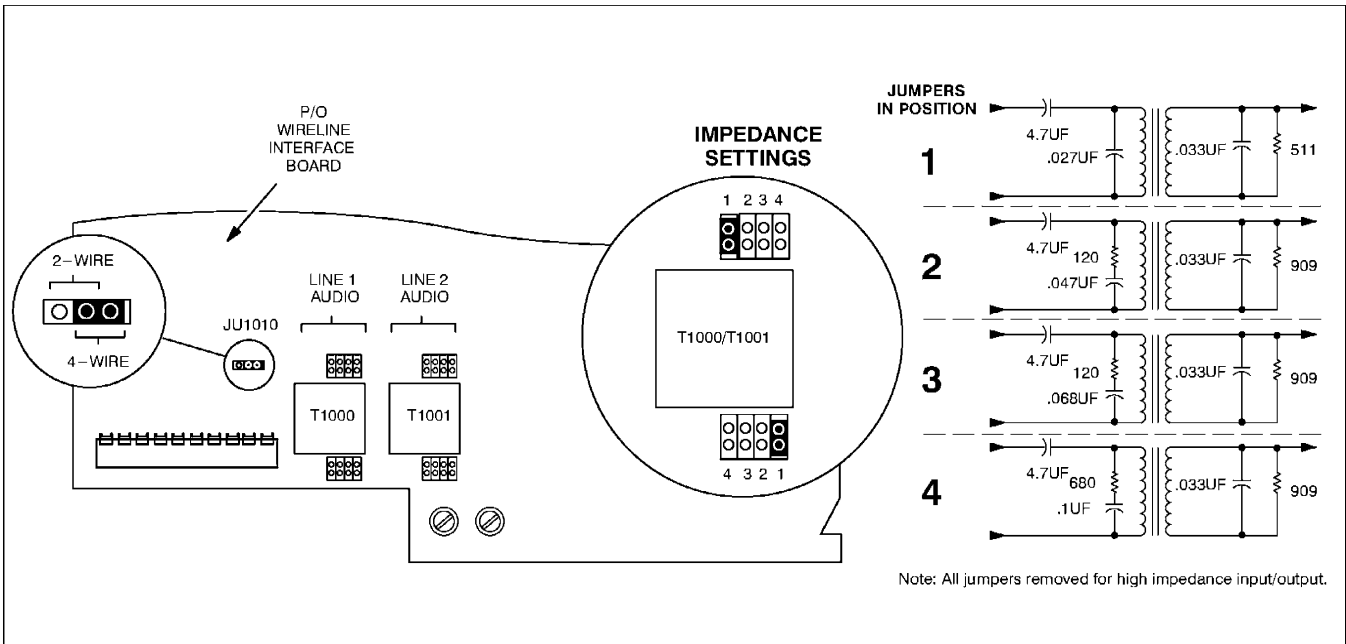

**Figure 3.** Wiring Connections for Main/Standby Configuration

## 4 RSS PROGRAMMING

In order to enable the Main/Standby Feature, the following two tasks must be performed using the *Quantar/Quantro* Radio Service Software (RSS) program. (Refer to the *RSS User's Guide 68P81085E35* for details on performing the following tasks.)

- Step 1.** Connect a PC running the RSS program to one of the two stations and read the station codeplug.
- Step 2.** Access the *Hardware Configuration* screen and set the Main/Standby field for **MAIN** (for station designated as Main) or **STANDBY** (for station designated as standby) as shown in Figure 4.
- Step 3.** Perform all other RSS programming tasks to configure the station (as described in the *RSS User's Guide 68P81085E35*).

MOTOROLA RADIO SERVICE SOFTWARE BASE STATION PRODUCTS VER:XX.XX.XX MAIN:SERVICE:HARDWARE CONFIGURATION		Please Enter The Serial Number Type Alphanumeric/Punctuation Chars.							
Serial Number: Hardware Platform: QUANTAR		Station Name:							
System Type: CONVENTIONAL Rx Freq Band 1: UIIF_R2 438-470 MHz Rx Freq Band 2: NONE		Station Type: ANALOG ONLY Tx Freq Band: UIIF_R2 438-470 MHz IR Freq Band: NONE							
PA Power Rating: 25 Watts Power Supply: AC LOW		Output limited to xxx Watts Battery Type: NONE							
OPTIONS: Wireline: 8-WIRE Freq Ref: INTERNAL - STD Multi-Coded Squelch: DISABLED Scanning Receiver		WildCard: ENHANCED Simulcast Operation: DISABLED MRTI Interface: DISABLED Site Number: 1 Main/Standby: MAIN							
F1 HELP	F2	F3	F4	F5	F6	F7	F8 VALIDATE CONFIG	F9	F10 EXIT

Set to MAIN (for Main Station)  
Set to STANDBY (for Standby Station)

**Figure 4.** Making Main/Standby RSS Setting

- Step 4.** Access the *Wildcard Configuration* menu screen and select *State/Action Configuration*. Press **F4** to set the WildCard Tables to their default values. This ensures that the tables for the Main/Standby Feature are programmed with the factory values. Note that any WildCard Tables that have been custom created by the customer will be deleted, and that any customization of the default tables will be returned to the factory default values. Re-enter these if the functions are still required for this installation.
- Step 5.** Save the codeplug to the station.
- Step 6.** Repeat Steps 1 thru 4 for the other station.

## 5 MAIN/STANDBY OPERATION

### *Three Modes of Main/Standby Operation*

The Main/Standby Feature offers three modes of switching from MAIN to STANDBY and from STANDBY to MAIN:

- **Automatic (or “Hot”) Switchover** — Whenever one of the modules fails in the MAIN station, the MAIN station will automatically set itself to STANDBY and will signal its companion station to set itself to MAIN. The MAIN station will not automatically switch to STANDBY unless it is connected to its companion station and the companion station has not indicated a failure mode. (To disable automatic switchover mode, refer to page 8.)
- **Tone Remote Control Switchover** — Sending function tone 4 to the stations will force the MAIN station to STANDBY mode and the STANDBY station to MAIN mode. Sending function tone 5 to the stations will force the MAIN station back to MAIN mode and the STANDBY station back to STANDBY mode. If either station has detected a module failure, neither switchover will occur. (To change the particular function tones that trigger these events, refer to 9.)
- **External Control Switchover** — An external control device may be connected to Input 2 on Connector #17 (located on backplane of both stations) to initiate a Main-to-Standby or a Standby-to-Main switchover to occur. Grounding this signal causes the MAIN station to go to STANDBY mode and the STANDBY station to go to MAIN mode. Pulling this signal high causes the STANDBY station to go to MAIN mode and the MAIN station to go to STANDBY mode.

### *Additional Functions Provided by the Main/Standby Feature*

- **Antenna Relay Control** — When the MAIN station is operating in MAIN mode, the relay driven output 8 is energized. The use of this closure is left up to the user. Typically a user will use this closure to drive an external relay which connects the antenna to whichever station is operating in MAIN mode.
- **Status Request** — Utilizing TRC function tone 14, the console operator can request which station is in MAIN mode. One beep will be returned if the MAIN station is in MAIN mode and two beeps if the STANDBY station is in MAIN mode.
- **Reset** — Utilizing TRC function tone 15, both stations will reset.

## 6 CUSTOMIZING MAIN/STANDBY OPERATION

### Default Operation

The Main/Standby Feature is implemented using the Radio Service Software (RSS) WildCard Feature. As shipped from the factory, the RSS contains 21 WildCard Tables for the Main station and 20 WildCard Tables for the Standby station. These tables contain default settings that define the basic operation of the Main/Standby Feature (i.e., control of Main and Standby status of two interconnected stations via pre-defined Tone Remote Control function tones to provide backup redundancy in the event of a station failure).

### Customizing Main/Standby Operation

Although all of the Main/Standby WildCard Tables are user configurable (via the RSS), it is recommended that only the following functions be customized by the user. Follow the instructions in Chapter 11 of the *RSS User's Guide 68P81085E35* for details on modifying the WildCard Tables.

- **Disable Automatic (Hot) Switchover** — Delete WildCard Table 8 in both stations

STATE CONDITION					
TABLE 4 OF 20					
Description:					
State	Cond	MAIN/STANDBY #	State	Cond	State
EVENT FLAG #	AND	INPUT #			
ACTION:			TRACTION:		
-		STANDBY	-		NULL
-		MPIT DISABLE	-		
-		KX WL MUTE	-		
-		WAIT	30		
-		CLR OUTPUT	3		
-		CLR OUTPUT	5		
-					
-					
-					

- Select Alternate Function Tones to Activate Main/Standby Switchover (default is FT4 to switch, FT5 to switch back)** — To modify the Function Tone that initiates the initial switch from Main to Standby, modify the TRC TONE entry in WildCard Table 19 in the MAIN station and WildCard Table 17 in the STANDBY station.

To modify the Function Tone that initiates the switch back from Standby to Main, modify the TRC TONE entry in WildCard Table 18 in the MAIN station and WildCard Table 18 in the STANDBY station.

**Modify TRC Tone field to change Main-to-Standby Switchover**

**Main**

TABLE 19 OF 21					
STATE CONDITION					
State	Description	Cond	State	Cond	State
TRC TONE	4	AND NOT	EVENT FLAG 12		
ACTION					
	STANDBY				NULL
	MRTI DISABLE				
	RX HL MUTE				
	WAIT	30			
	CLR OUTPUT	1			
	CLR OUTPUT	2			

---

**Standby**

TABLE 17 OF 19					
STATE CONDITION					
State	Description	Cond	State	Cond	State
TRC TONE	4	AND NOT	EVENT FLAG 12		
ACTION					
	SET OUTPUT	1			NULL
	SET OUTPUT	2			
	WAIT	30			
	RX HL ENABLE				
	MRTI ENABLE				
	MAIN				

**Modify TRC Tone field to change Standby-to-Main Switchover**

**Main**

TABLE 18 OF 21					
STATE CONDITION					
State	Description	Cond	State	Cond	State
TRC TONE	5	AND NOT	EVENT FLAG 12		
ACTION					
	SET OUTPUT	1			NULL
	SET OUTPUT	2			
	WAIT	30			
	RX HL ENABLE				
	MRTI ENABLE				
	MAIN				
	SET EVENT FLAG	9			

---

**Standby**

TABLE 18 OF 20					
STATE CONDITION					
State	Description	Cond	State	Cond	State
TRC TONE	5	AND NOT	EVENT FLAG 12		
ACTION					
	STANDBY				NULL
	MRTI DISABLE				
	RX HL MUTE				
	WAIT	30			
	CLR OUTPUT	1			
	CLR OUTPUT	2			

- Select Alternate Function Tone to Initiate a Status Request (default is FT14)

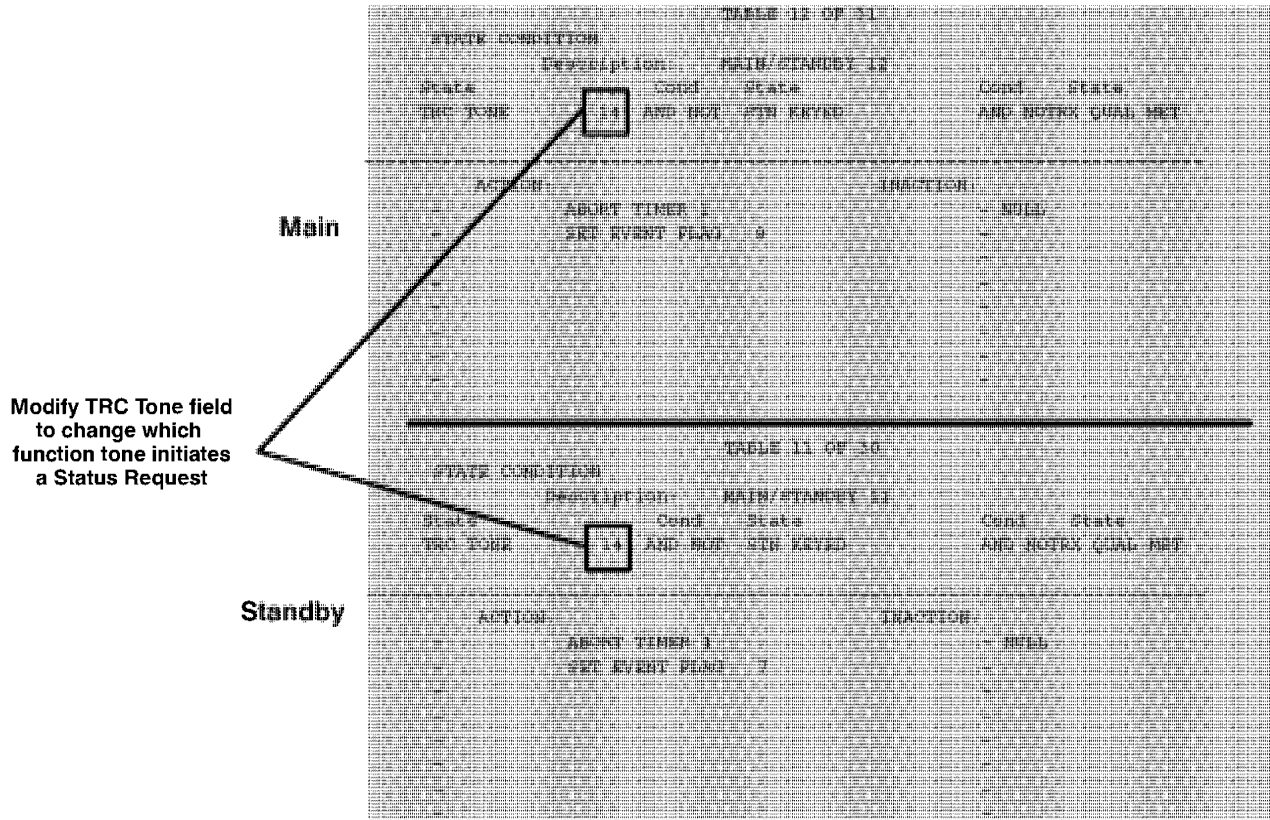

- Select Alternate Function Tone to Initiate a Reset to Both Stations (default is FT15)

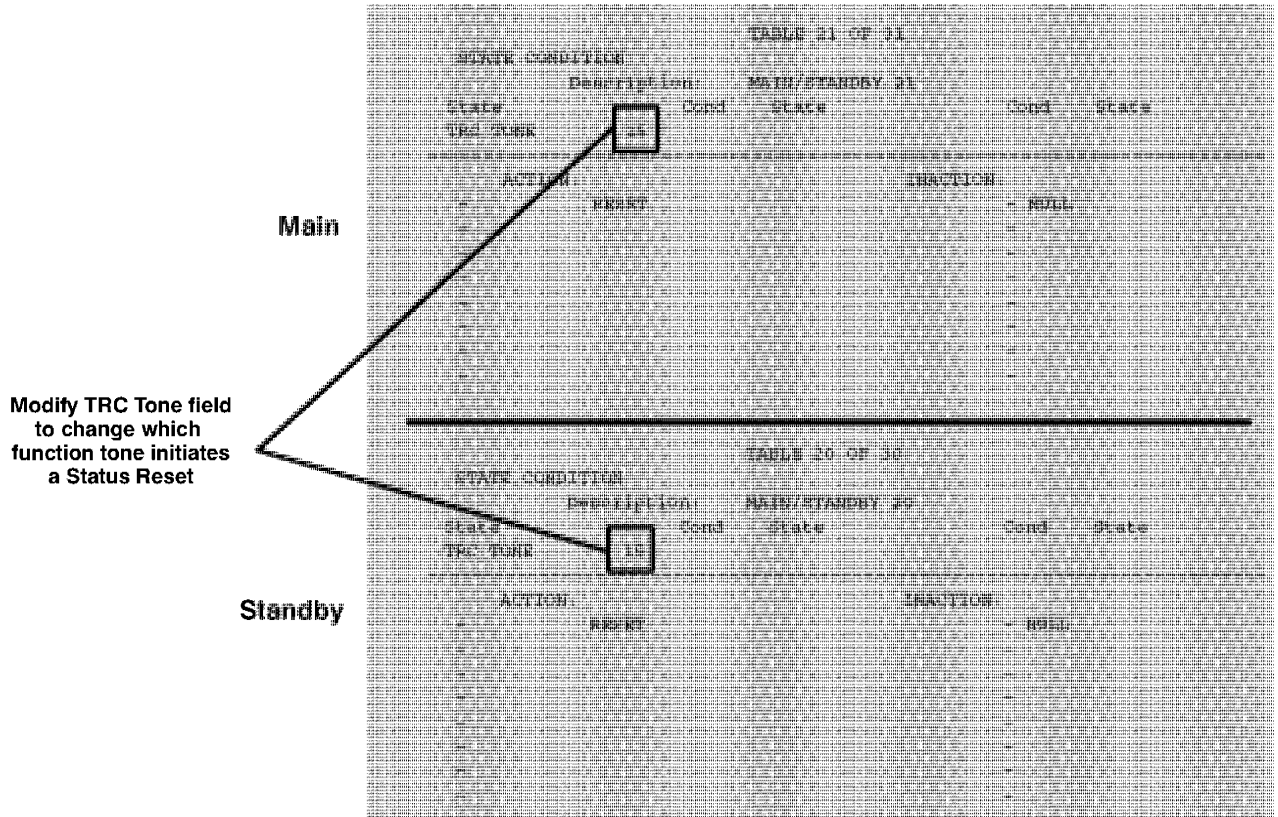



# FAST KEYUP FEATURE

For *Quantar* and *Quantro* Stations

---

---

## 1 OVERVIEW

The Fast Keyup Feature allows *Quantar* and *Quantro* stations to be keyed up by an external device (such as a Data Controller) in approximately 12 milliseconds (*Quantar* VHF and *Quantro* UHF) or 10 milliseconds (all other stations). Note that normal keyup time using the station's PTT input is approximately 50 msec.

In order to implement this feature, three signals (TX Audio, RX Audio, and PTT) must be connected between the station and the external device. Also, an RSS parameter setting must be made to properly configure the feature's operation. This manual provides step-by-step instructions for performing these tasks.

**Note** — *The Fast Keyup Feature applies only to non-Simulcast, Analog Conventional stations.*



## 2 ELECTRICAL CONNECTIONS

As shown in Figure 1, the following signals must be connected properly between the station and the external device:

- PTT
- TX Audio
- RX Audio

Additionally, there are two possible connection configurations — **Direct Connection** and **Splatter Filter Connection**. The Direct Connection configuration is chosen when the external device provides the required splatter filtering of the TX Audio signal. The Splatter Filter Connection configuration is chosen when the station's internal splatter filter is to be utilized (no splatter filtering provided by the external device).

The following procedures describe how to make the signal connections for each type of connection configuration.

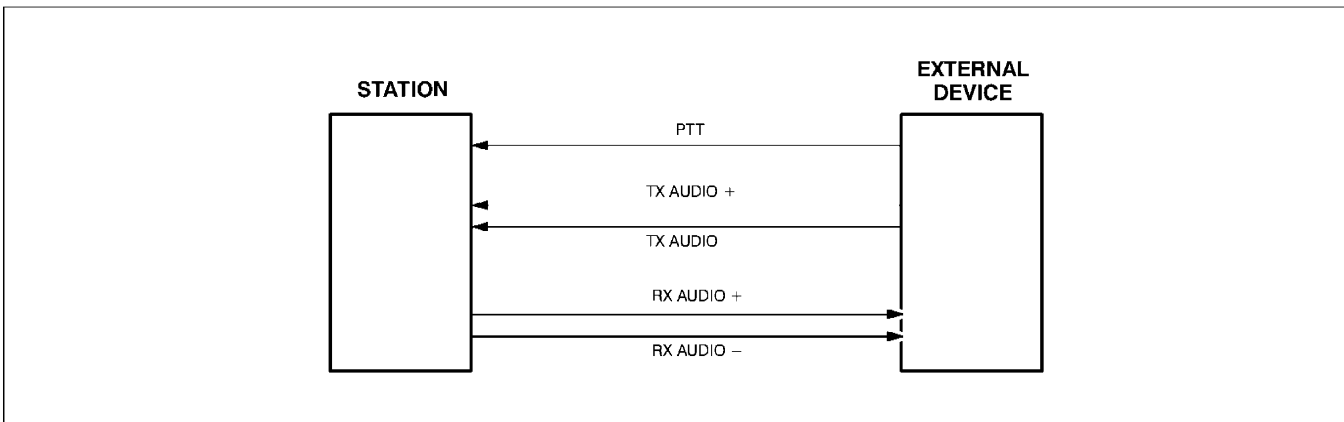
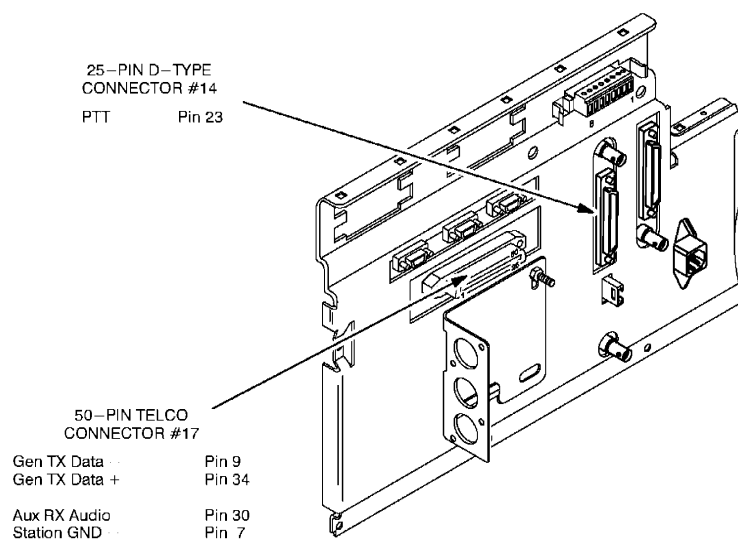

**Figure 1.** Fast Keyup Feature Wiring Diagram

## Wiring Details for Direct Connection and Splatter Filter Configurations

- Step 1.** Connect the PTT signal from the external device to Connector #14 on the station backplane as shown below.
- Step 2.** Connect TX Audio (+) and (–) from the external device to Connector #17 on the station backplane as shown below.
- Step 3.** Connect Aux RX Audio and GND from the station backplane Connector #17 to the external device as shown below.

### Direct Connection Configuration



### Splatter Filter Connection Configuration

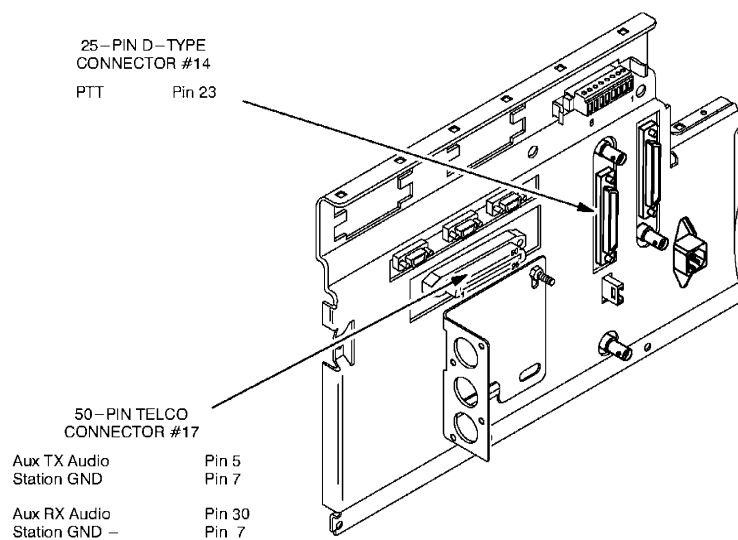

### 3 RSS PROGRAMMING

Using the *Quantar/Quantro* Radio Service Software (RSS) program (Version R09.05.00 or higher), make the following codeplug data changes to allow proper Fast Keyup operation. (Refer to the *RSS User's Guide 68P81085E35* for details on making codeplug programming changes.)

**Table 1.** Codeplug Data Changes for Fast Keyup Operation

Codeplug Data Parameter	RSS User's Guide Location
<p>Set the <b>Fast Key–Up</b> parameter to <i>WIDEBAND</i> for Direct Connection configurations, or to <i>AUX TX</i> for Splatter Filter Connection configurations.</p> <p><b>Note</b> <i>AUX TX</i> selection is not compatible with <i>MRTI</i>.</p>	<p>Programming the RF Configuration Data (p/o Chapter 4)</p>

## 4 FAST KEYUP PERFORMANCE CHARACTERISTICS

Figure 2 shows the performance characteristics of the station after implementing the Fast Keyup Feature.

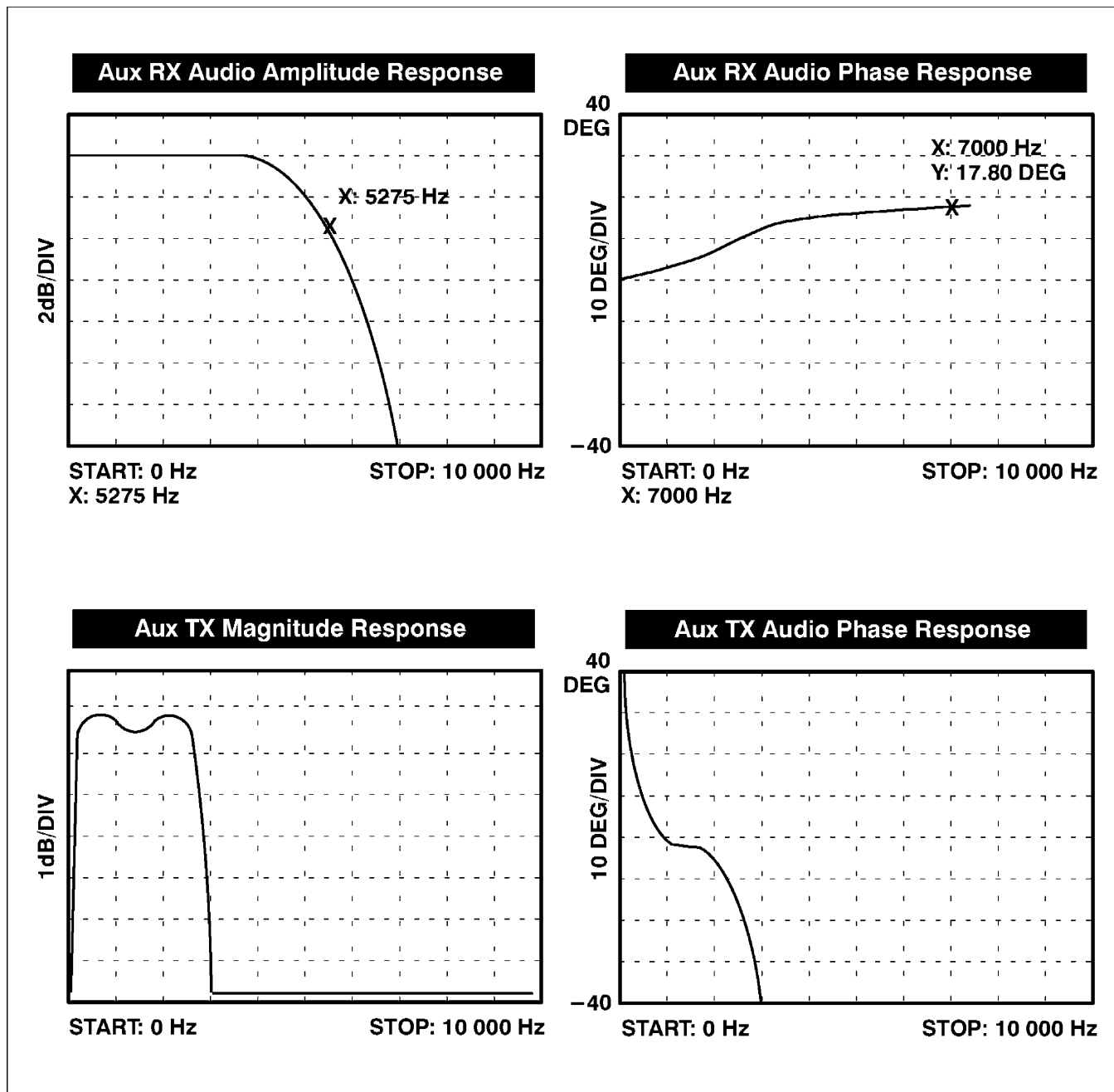

**Figure 2.** Fast Keyup Performance Characteristics



# DUAL CONTROL OF GATED ACCESS VIA TRC AND SAM

For *Quantar* and *Quantro* Stations  
Servicing MCS Users

## 1 OVERVIEW

This section describes how to program the station (*Quantar* or *Quantro*) and the Station Access Module (SAM) to allow two functions (repeater setup/knockdown and “gated access” to be controlled (toggled on and off) by both of the following methods:

- Console Operator using TRC tones
- Subscriber Unit using DTMF or MDC 1200 signaling transmitted over the air

By utilizing the MCS Feature and controlling the repeater setup/knockdown and “gated access” functions, an effective “Mutual Aid” talk group configuration can be created. In this configuration, subscribers within a specific coverage area (local subscribers) are assigned a “primary” PL and have their MCS User Access field set to ENABLED. These subscribers will repeat as normal (assuming station is toggled to “repeater setup” mode). Should emergency conditions require other subscribers outside of the local area to enter the communications area, these subscribers will be able to communicate with each other (as well as local users) via the same local repeater if they have been assigned with a “secondary” PL and have their MCS User Access set to GATED. Additionally, the repeat mode (setup or knocked down) and gated access mode (enabled or disabled) may be controlled by both a console operator or a subscriber unit. (Note that Gated User Access is disabled upon station reset. Gated Access must be enabled via over-the-air transmissions to the SAM module, or via TRC tones from the console.)

The following table shows how the repeater access and “gated access” functions may be controlled to provide access to local and visiting subscribers. Refer also to Figure 1 (showing a typical repeater access call flow chart **before** Gated Access is employed), and Figure 2 (showing a repeater access call flow chart **after** Gated Access is incorporated).

Gated Access	Repeater Up/Down	Subscriber Operation
Enabled	Up	<ul style="list-style-type: none"><li>• Local subscribers (primary PL) will repeat.</li><li>• Emergency subscribers (secondary PL and MCS User Access set to GATED) will repeat.</li></ul>
Enabled	Down	<ul style="list-style-type: none"><li>• No subscribers will repeat.</li></ul>
Disabled	Up	<ul style="list-style-type: none"><li>• Only local subscribers (primary PL) will repeat.</li></ul>
Disabled	Down	<ul style="list-style-type: none"><li>• No subscribers will repeat.</li></ul>

In order to perform the procedures in this section, you must program certain parameters in the *Quantar* or *Quantro* station and the Station Access Module (SAM). In order to do this, you will need the following software programs:

- RVN5002 *Quantar/Quantro* Radio Service Software (RSS) Version R09.05.00 or higher)
- RVN4110 Station Access Module (SAM) Radio Service Software (RSS) Version R01.01 or higher)

### Call Flow Prerequisites

- MCS User Access is Enabled (but not Gated)
- Analog Rptr Activation RSS Parameter set to SC
- Local Subscribers are using "Primary" PL

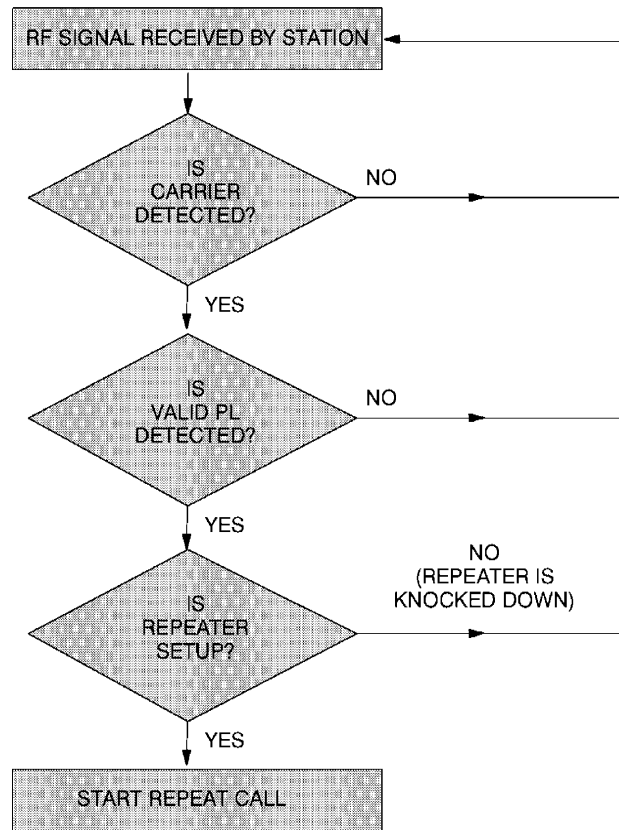
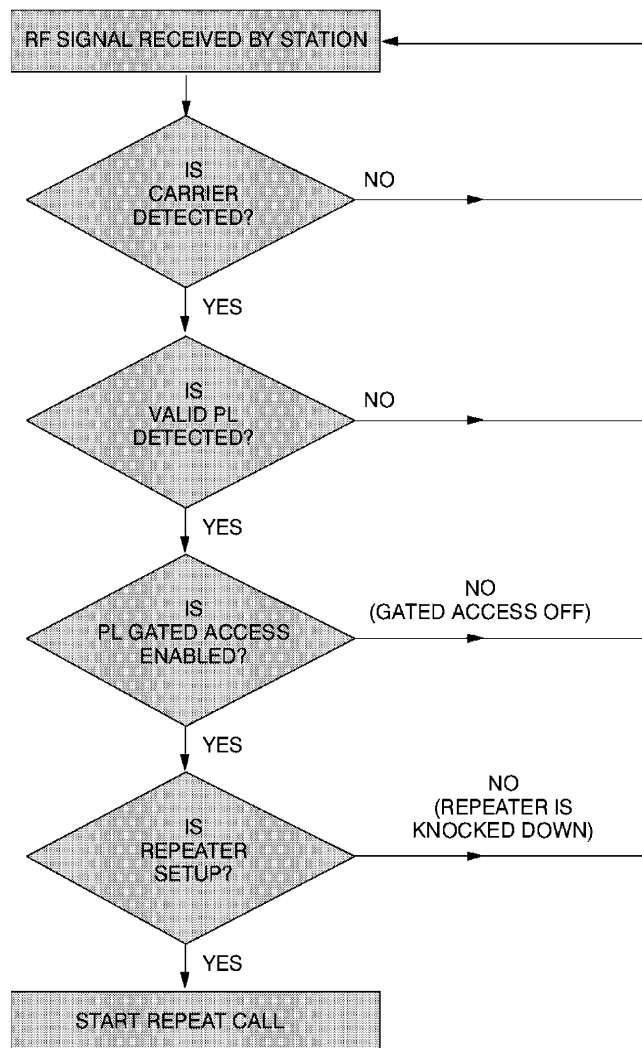

Figure 1. Typical Call Flow Chart Without Gated Access Incorporated

**Call Flow Prerequisites**

- MCS User Access is set to “Gated”
- Analog Rptr Activation RSS Parameter set to SC
- Emergency conditions exist, in which non-Local Subscribers are using “Secondary” PL

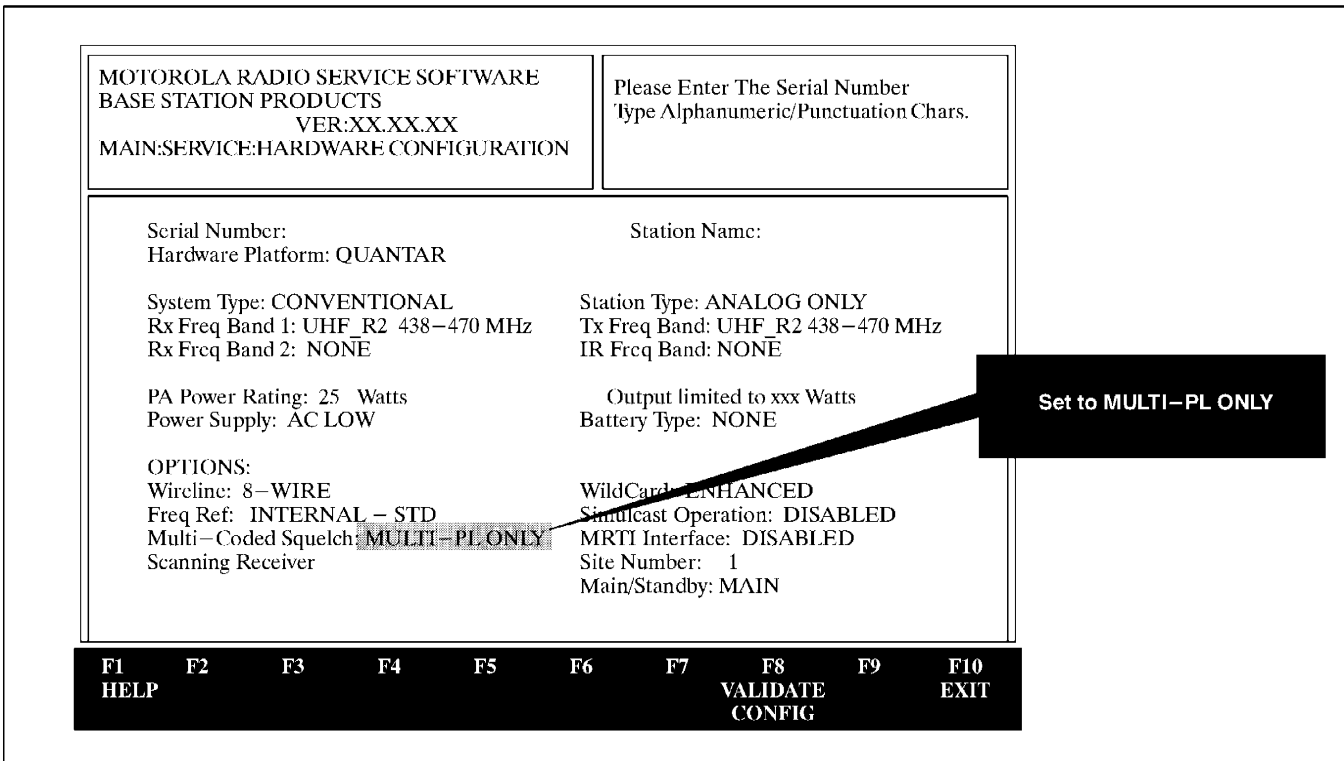

**Figure 2.** Typical Call Flow Chart With Gated Access Incorporated

## 2 STATION RSS PROGRAMMING

In order to support dual control of gated access by TRC and SAM, certain station parameters must be programmed using the *Quantar/Quantro* Radio Service Software (RSS) program (Version R09.05.00 or higher). (Refer to the *RSS User's Guide 68P81085E35* for details on making these settings.)

- Step 1.** Connect a PC running the Station RSS program to one of the two stations and read the station codeplug.
- Step 2.** Access the *Hardware Configuration* screen and set the *Multi-Coded Squelch* field to **MULTI-PL ONLY** to enable the Multi-Coded Squelch feature (as shown in Figure 3).

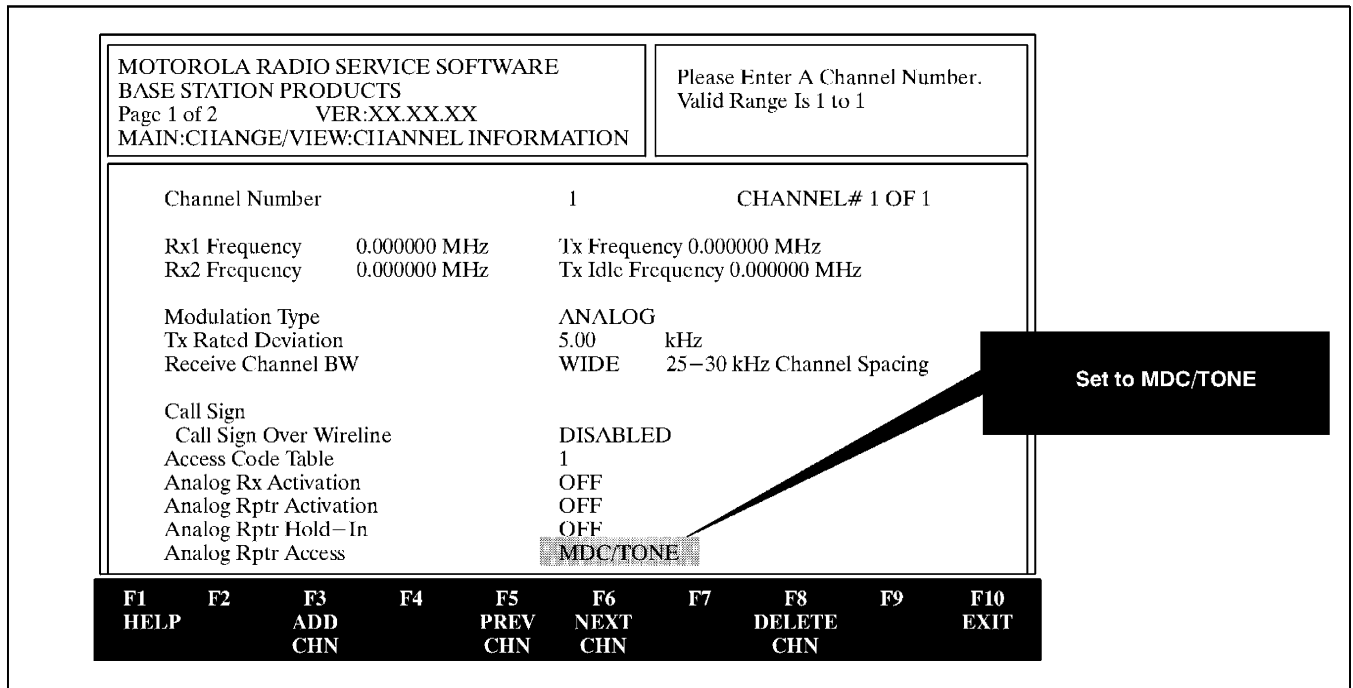

**Figure 3.** Making *Multi-Coded Squelch* RSS Setting

*continued on next page* 



**Step 3.** Access Page 1 of the *Channel Information* screen and set the *Analog Rptr Access* field to **MDC/TONE** (as shown in Figure 4) to enable the Station Access Module (SAM).



**Figure 4.** Making *Analog Rptr Access* RSS Setting

**Step 4.** Access the *RF Configuration Data* screen and set the *Repeater Operation* field for **REPEATER** (as shown in Figure 5).

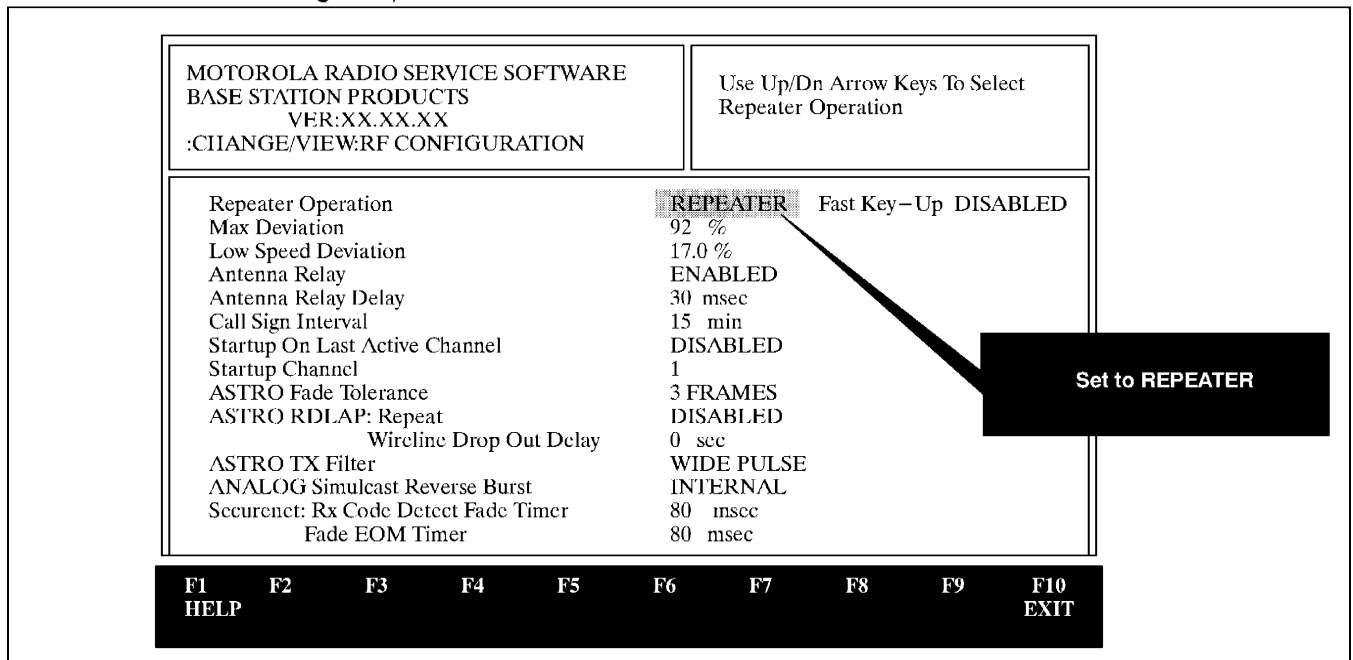

**Figure 5.** Making *Repeater Operation* RSS Setting

continued on next page

**Step 5.** Access the *Multi-Coded Squelch* screen, enter the desired number of users, then set the “secondary” PL’s *User Access* field to **GATED** (as shown in Figure 6). Refer to the *RSS User’s Guide 68P81085E35* for details on setting up users in the *Multi-Coded Squelch* screen.

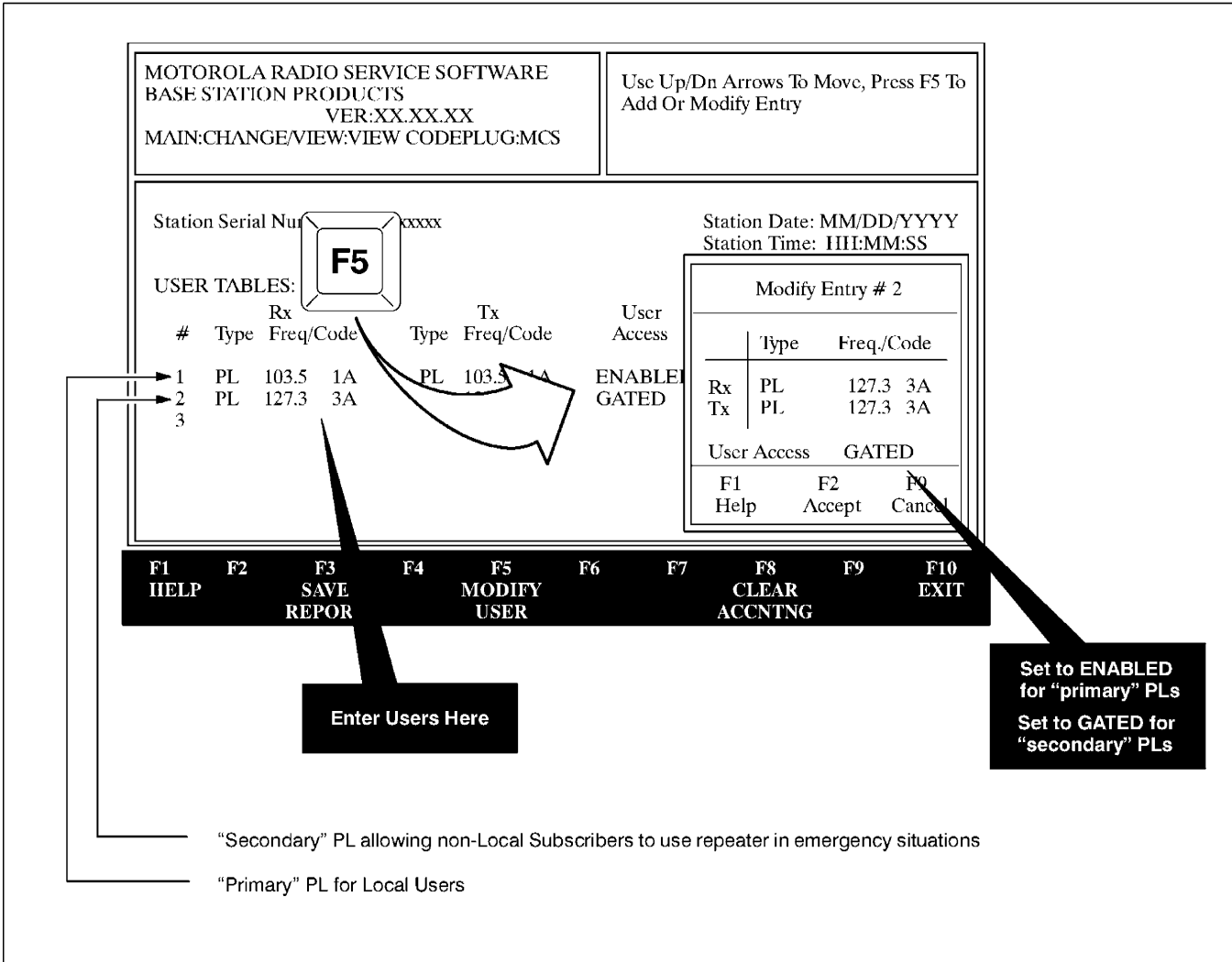

**Figure 6.** Entering Users and Setting to Gated

**Step 6.** Access the *TRC Commands* screen and program tones FT3–FT6 (as shown in Figure 7). Refer to the *RSS User's Guide 68P81085E35* for details on programming the tones.

MOTOROLA RADIO SERVICE SOFTWARE BASE STATION PRODUCTS Page 1 of 3      VER:XX.XX.XX MAIN:CHANGE/VIEW:TRC COMMANDS		Enter Command or Use Tab/Shift Tab and Enter To Move Between Fields	
Guard Tone	2175 Hz	MORE	
FT1 —	2050 Hz	MONITOR	
FT2 —	1950 Hz	CIIN 001 KEY	
FT3 —	1850 Hz	RPT ON	
FT4 —	1750 Hz	RPT OFF	
FT5 —	1650 Hz	GATEACC ON	
F1	F2	F3	F4
F5	F6	F7	F8
F9	F10		
HELP			EXIT
MOTOROLA RADIO SERVICE SOFTWARE BASE STATION PRODUCTS Page 2 of 3      VER:XX.XX.XX MAIN:CHANGE/VIEW:TRC COMMANDS		Enter Command or Use Tab/Shift Tab and Enter To Move Between Fields	
FT6 —	1550 Hz	GATEACC OFF	
FT7 —	1450 Hz		
FT8 —	1350 Hz		
FT9 —	1250 Hz		
FT10 —	1150 Hz		
F1	F2	F3	F4
F5	F6	F7	F8
F9	F10		
HELP			EXIT

**Figure 7.** Programming TRC Tones FT3–FT6

◆ End of This Procedure ◆

### 3 SAM RSS PROGRAMMING

In order to support dual control of repeater access by TRC and SAM, certain SAM parameters must be programmed using the Station Access Module (SAM) Radio Service Software (RSS) program. (Refer to the *SAM RSS User's Guide 68P80309E35* for details on performing the following tasks.)

- Step 1.** Connect a PC running the RSS program to the RSS port on the front panel of the SAM module and read the SAM codeplug.
- Step 2.** For **DTMF operation**, access *Page 03* of the *SAM Decoder Selection* screen and program the **TARGET** and **ACT TBL** settings as shown in Figure 1. These settings establish the keypad sequences and corresponding Action Tables for Repeater Setup, Repeater Knockdown, Gated Access Enable and Gated Access Disable. Note that if there is default data already entered when opening the screen, overwrite the data with the data shown below.

MOTOROLA RADIO SERVICE SOFTWARE  
SAM with QUANTAR/QUANTRO  
Page = 03 of 03  
SAM DECODER SELECTION

Enter DTMF Target, Valid input is:  
0-9, A-D, #, \*, or X

-----

Set to **ENABLED..**

DTMF DECODER	<b>ENABLED</b>		SAM MODE# 00 of 01
DTMF INPUT	RECEIVER 1		

DTMF DECODER TARGET#	TARGET	ACT TBL	
01 .....	123*	03	
02 .....	456#	04	
03 .....	147*	06	
04 .....	369#	07	
05 .....			
06 .....			
07 .....			
08 .....			
09 .....			
10 .....			
11 .....			

F1	F2	F3	F4	F5	F6	F7	F8	F9	F10
HELP				PRINT	ADD	DELETE	ACTION		EXIT
				PAGE	MODE	MODE	EDIT		

Enter Action Table numbers to correspond to keypad sequences 01 thru 04. Use 03, 04, 06, and 07 as shown. (Note that if a table does not exist, the RSS will prompt you to create one.)

Enter desired keypad sequences for:  
 Gated Access Enable – 123\*  
 Gated Access Disable – 456#  
 Repeater Setup – 147\*  
 Repeater Knockdown – 369#  
 (Keypad sequences are shown here as examples. You may choose other sequences as desired.)

**Figure 1.** Making DTMF SAM Decoder Selection RSS Settings

*continued on next page*

For **MDC 1200 operation**, access *Page 02* of the *SAM Decoder Selection* screen and program the *OPCODE*, *ID*, and *ACT TBL* settings as shown in Figure 2. These settings establish the IDs and corresponding Action Tables for Repeater Setup, Repeater Knockdown, Gated Access Enable and Gated Access Disable. Note that if there is default data already entered when opening the screen, overwrite the data with the data shown below.

MOTOROLA RADIO SERVICE SOFTWARE  
 SAM with QUANTAR/QUANTRO  
 Page = 02 of 03  
 SAM DECODER SELECTION

Use UP/DOWN Arrows to Change Fields

Set to **ENABLED..**

BINARY DECODER                      **MDC1200**                      SAM MODE# 00 of 01  
 BINARY INPUT                      RECEIVER 1

BINARY DECODER TARGET#	OPCODE	ID	ACT TBL
01 .....	REPEAT ACC	0001	03
02 .....	REPEAT ACC	0002	04
03 .....	REPEAT ACC	0003	06
04 .....	REPEAT ACC	0004	07
05 .....			
06 .....			
07 .....			
08 .....			
09 .....			
10 .....			
11 .....			

Enter Action Table numbers to correspond to IDs 0001 thru 0004. Use 03, 04, 06, and 07 as shown.

The ID column reflects the MDC 1200 ID transmitted by the subscriber unit. IDs 0001 thru 0004 are shown here as examples. You may choose other IDs as desired.

Select REPEAT ACC for IDs 01 thru 04. (You MUST select REPEAT ACC. Do not use the Repeater Setup or Repeater Knockdown selections.)

F1	F2	F3	F4	F5	F6	F7	F8	F9	F10
HELP				PRINT	ADD	DELETE	ACTION		EXIT
				PAGE	MODE	MODE	EDIT		

**Figure 2.** Making MDC 1200 SAM Decoder Selection RSS Settings

continued on next page

**Step 3.** Access the *SAM Action Tables* screen and program Tables 03 and 04 as shown in Figure 3. These Action Tables control the Gated Access functions (enabled and disabled). Note that if there is default data already entered when opening the tables, overwrite the data with the data shown on the facing page.

*continued on next page* 

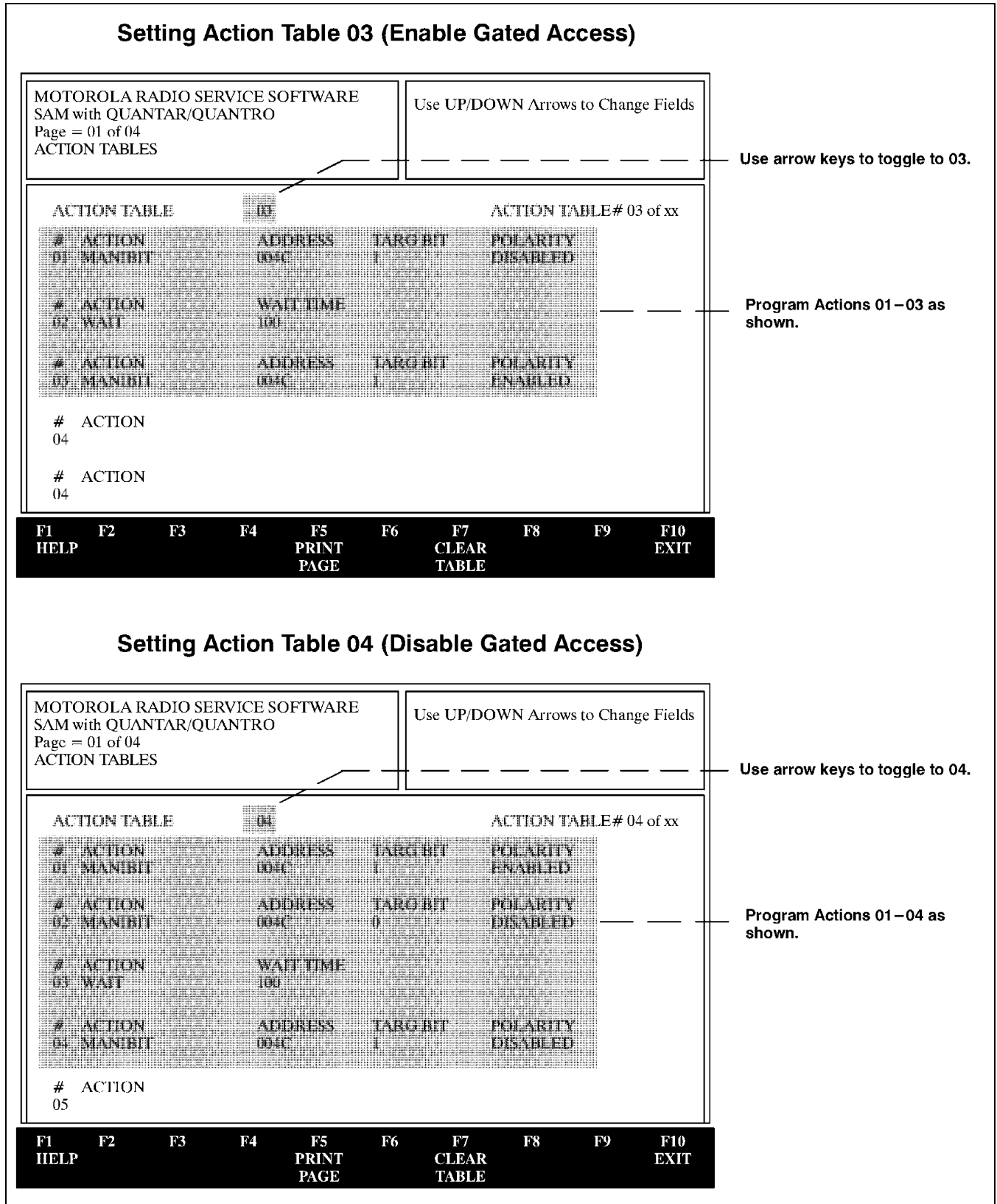
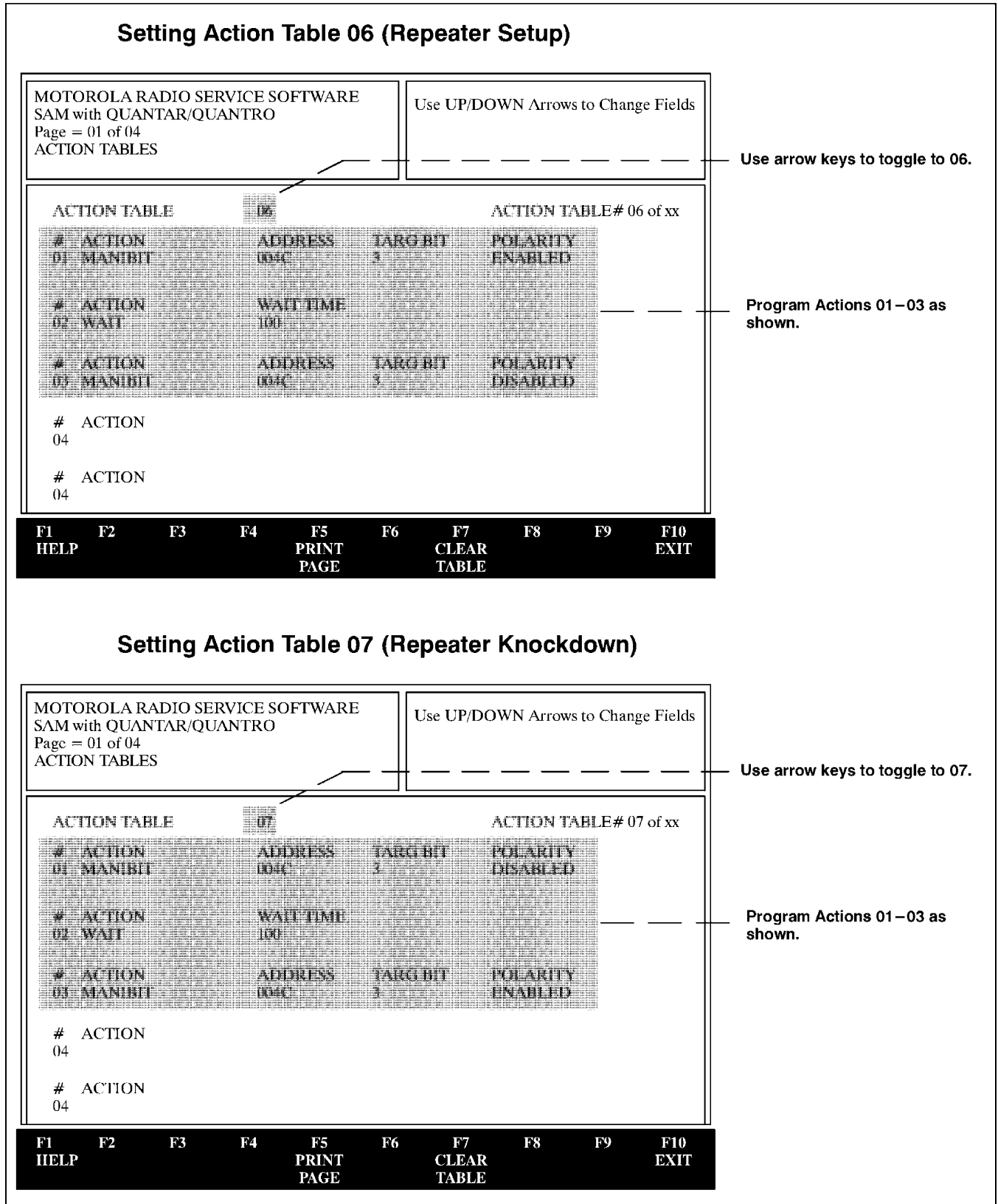

**Figure 3.** Programming the Action Tables for Gated Access Enable/Disable

**Step 4.** Access the *SAM Action Tables* screen and program Tables 06 and 07 as shown in Figure 4. These Action Tables control the Repeater Setup and Knockdown functions. Note that if there is default data already entered when opening the tables, overwrite the data with the data shown on the facing page.

◆ **End of This Procedure** ◆





**Figure 4.** Programming the Action Tables for Repeater Setup/Knockdown



# INPUT/OUTPUT SPECIFICATIONS FOR EXTERNAL CONTROLLERS

For *Quantar* and *Quantro* Stations

## 1 OVERVIEW

The *Quantar* and *Quantro* stations can be connected to external third-party controllers to accommodate various system applications. Connections between the station and the external controller equipment typically involve the following primary interface signals (available on the station backplane System Connector #17):

- Line 1 + and Line 1 —
- Aux TX Audio (or Aux PL Audio)
- Aux RX Audio
- Carrier Indication + and Carrier Indication —
- PTT + and PTT —

To facilitate making connections between the station and external controller, this section provides electrical characteristics, frequency response curves, and other interface details for the primary interface signals.

**Note** When the WildCard option is purchased (required to configure inputs/outputs for connection to an external controllers) and is then enabled (via the RSS), the pre-defined functionality of the signals on System Connector J17 as shown in the Backplane section of this manual (e.g., J17-Pin 22 is Ext PTT +, J17-Pin 11 is Ext Failsoft, etc.) is lost.

In order to restore the pre-defined signals, you must press **F4 (SET TO DEFAULT)** on any of the WildCard RSS screens. Doing so automatically creates a set of WildCard Tables that now determine J17's signal functionality. The **Editing WildCard Tables** section (page 8) may now be used to change the signal functionality, as desired.

## 2 ELECTRICAL CONNECTIONS

Figure 1 shows the pin-out locations of the primary interface signals available on System Connector #17.

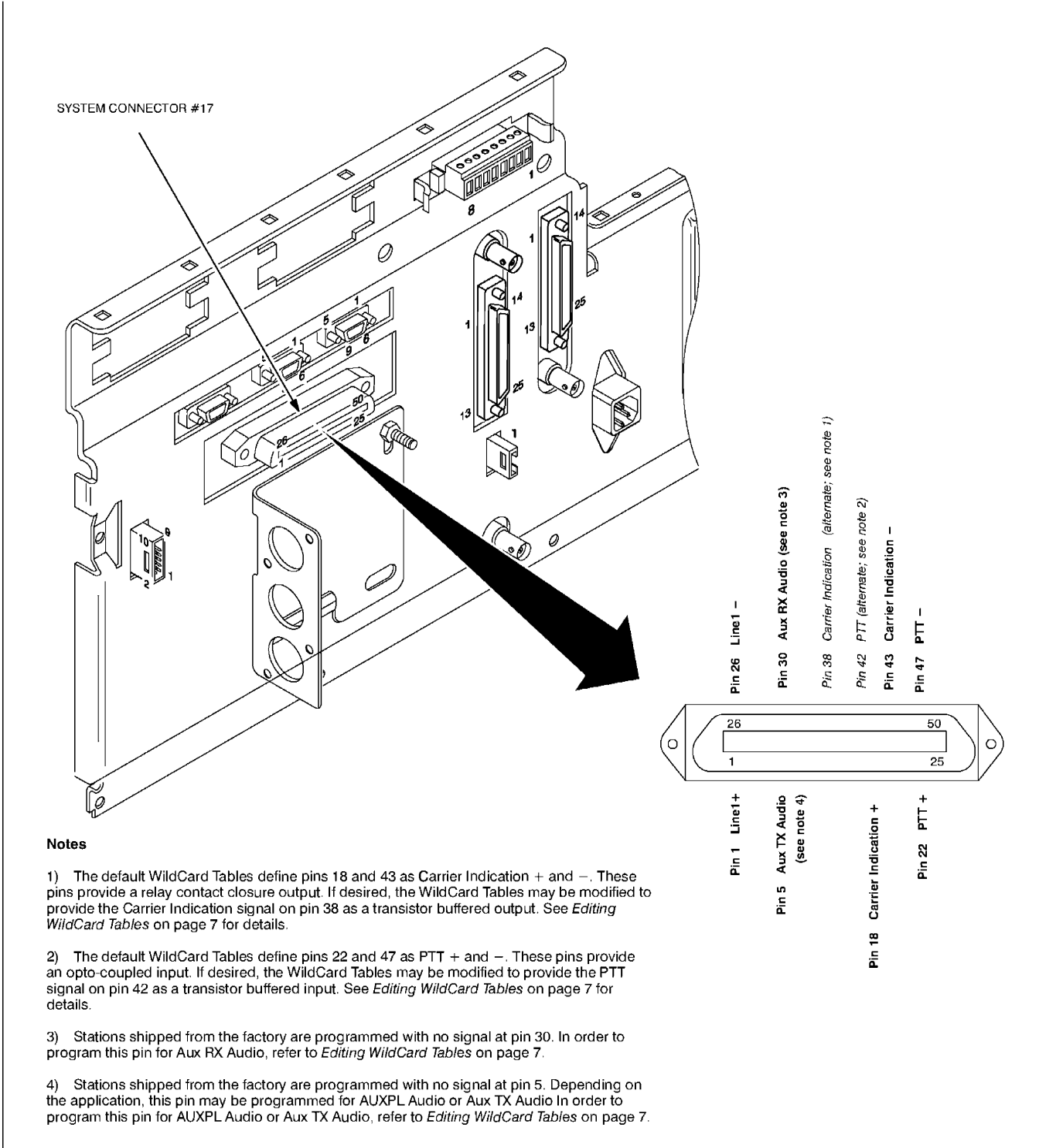

**Figure 1.** Signal Locations on System Connector #17

## 3 ELECTRICAL CHARACTERISTICS

This section provides the electrical characteristics, frequency response curves, and other interface details for the primary interface signals.

### Line 1 + and Line 1 — (J17—Pins 1 and 26)

#### General Characteristics

Line 1 + and Line 1 — provide a balanced phone line input for incoming audio signals to the station. The input impedance is set by jumpers located on the Wireline Interface Board. The jumpers are set at the factory for 600 $\Omega$  impedance. You may change the impedance (if desired) by changing the jumpers as described in the appropriate (4-wire or 8-wire) Wireline Interface Board section in this manual.

#### Phone Line Specifications

Most telephone companies recognize either “3002” or “Type 5” as designations to define phone line types and associated electrical specifications. Telephone lines meeting the specifications for either of these types are acceptable for use with the *Quantar* station. The following table shows the specifications for “3002” and “Type 5” phone line types.

**Type 5 and “3002” Phone Line Specifications**

Parameter	Type 5 Specification	3002 Specification
Loss Deviation	$\pm 4.0$ dB	$\pm 4.0$ dB
C–Notched Noise	51 dBBrnCO	51 dBBrnCO
Attenuation Distortion: 504 to 2504 Hz 404 to 2804 Hz 304 to 3004 Hz	–2.0 to +8.0 dB –2.0 to +10.0 dB –3.0 to +12.0 dB	–2.0 to +8.0 dB spec not available –3.0 to +12.0 dB
Signal to C–Notched Noise Ratio	$\geq 24$ dB	$\geq 24$ dB
Envelope Delay Distortion: 804 to 2604 Hz	1750 $\mu$ sec	1750 $\mu$ sec
Impulse Noise Threshold	71 dBBrnCO	
Intermodulation Distortion: R2 R3	$\geq 27$ dB $\geq 32$ dB	$\geq 25$ dB $\geq 30$
Phase Jitter: 20–300 Hz 4–300 Hz	$\geq 10$ Degrees $\geq 15$ Degrees	$\geq 25$ Degrees $\geq 30$ Degrees
Frequency Shift	$\pm 3$ Hz	$\pm 5$ Hz

### Aux TX Audio (J17 – Pin 5)

*Note* In order for J17-Pin 5 to support the Aux TX Audio signal, you must edit the Wildcard Table as shown on page 11.

The **Aux TX Audio** signal is an unbalanced,  $470\Omega$  impedance input to the station. The input voltage range is  $-4.1\text{ V}$  to  $+4.1\text{ V}$  at 250 Hz to 3 kHz. The response curves for this signal are shown below.

**Aux Tx Audio Magnitude Response**

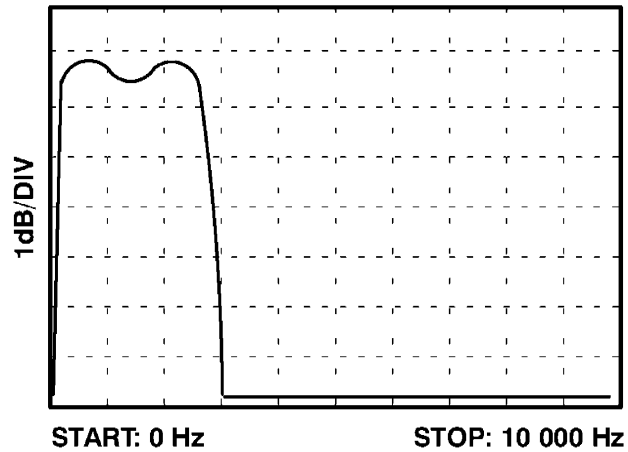

**Aux Tx Audio Phase Response**

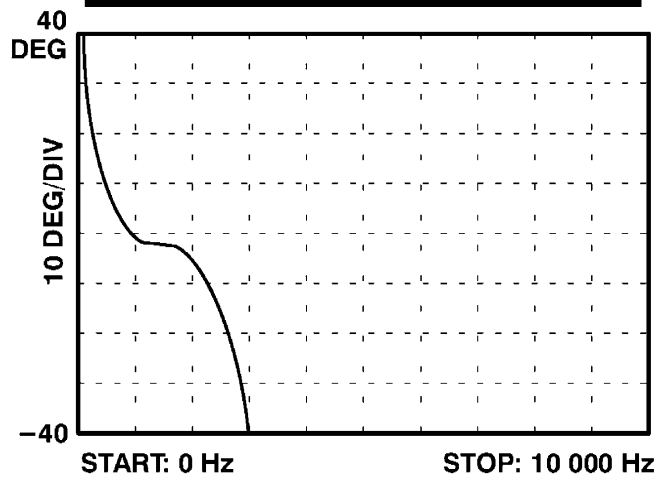

## Aux PL Audio (J17 – Pin 5)

*Note* In order for J17-Pin5 to support the Aux PL Audio signal, you must edit the Wildcard Table as shown on page 12.

The **Aux PL Audio** signal is an unbalanced,  $470\Omega$  impedance input to the station. The input voltage range is  $-4.1\text{ V}$  to  $+4.1\text{ V}$  at  $5\text{ Hz}$  to  $3\text{ kHz}$ . The response curves for this signal are shown below.

### Aux PL Audio Magnitude Response

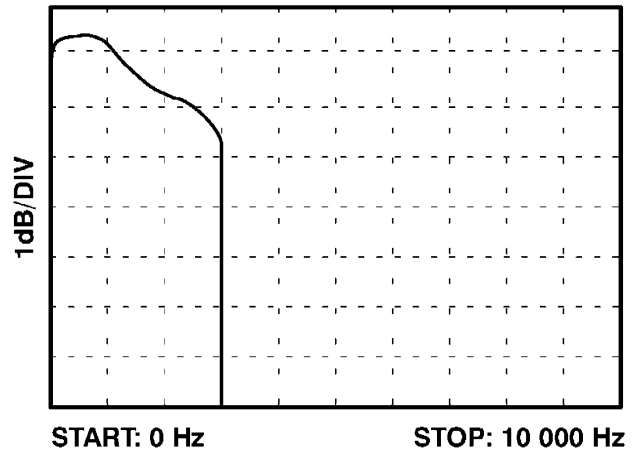

### Aux PL Audio Phase Response

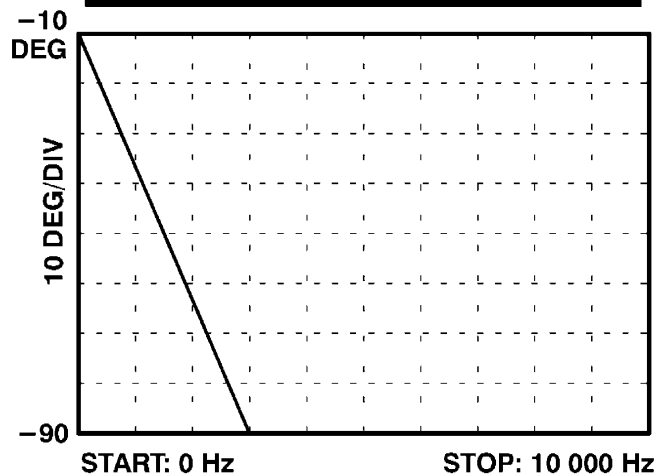

**Aux RX Audio  
(J17 – Pin 30)**

The Aux RX Audio signal is an unbalanced output from an operational amplifier with an output impedance of less than  $5\Omega$ . The output voltage range is 0 to 6.6V P-P at 0 to 6 kHz. The response curves for this signal are shown below.

**Aux RX Audio Amplitude Response**

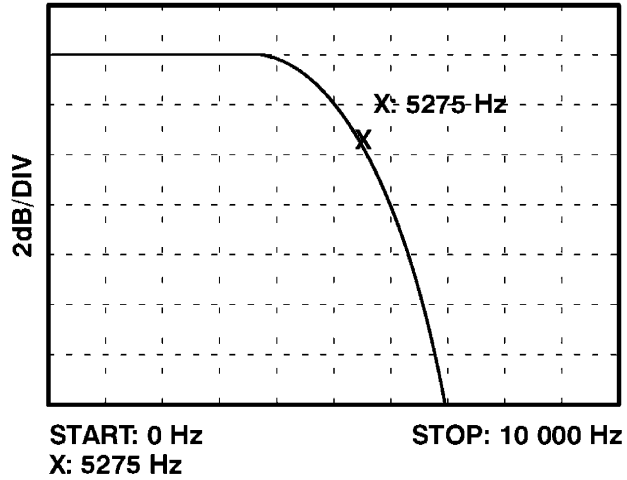

**Aux RX Audio Phase Response**

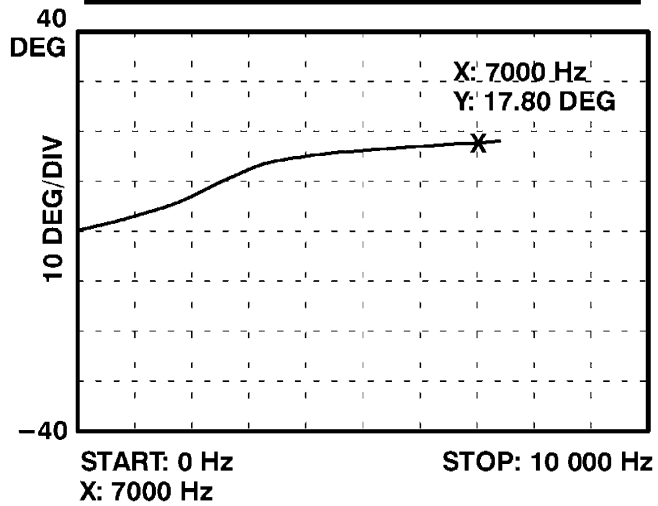

**Carrier Indication +/-  
(J17-Pins 18 and 43)**

The Carrier Indication + and Carrier Indication - signal provides a relay closure output, as shown below. (If desired, the WildCard Tables may be edited to provide the Carrier Indication signal on J17-Pin 38 as a transistor-buffered output. Refer to *Editing WildCard Tables* on page 7 for details.)

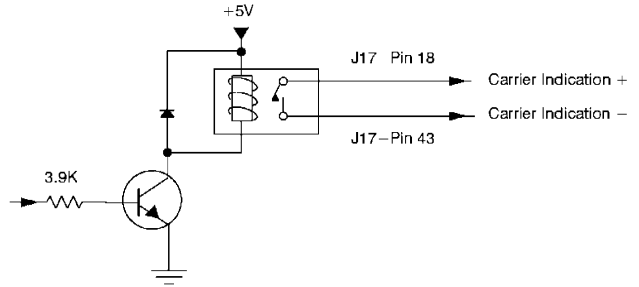

Typical Relay Closure Output Circuit

**PTT +/-  
(J17-Pins 22 and 47)**

The PTT + and PTT - signal provides an opto-isolated input, as shown below. (If desired, the WildCard Tables may be edited to provide the PTT signal on J17-Pin 42 as a transistor-buffered input. Refer to *Editing WildCard Tables* on page 7 for details.)

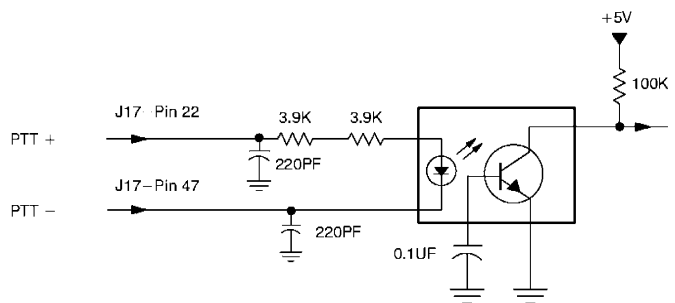

Typical Opto-Coupled Input Circuit



# 4 EDITING WILDCARD TABLES

You must edit certain WildCard Tables in order to cause certain signals to appear on specific pins on the System Connector J17. Instructions for modifying these WildCard Tables are provided in this section.

The WildCard Tables are programmed in the factory to provide:

- Carrier Indication + and – on J17–Pins 18 and 43 as a relay contact closure output
- PTT + and – on J17–Pins 22 and 47 as an opto-isolated input

If desired, the WildCard Tables may be modified to change the connector pin number and signal interface as follows:

- Carrier Indication on J17–Pin 38 as a transistor buffered output
- PTT on J17–Pin 42 as a transistor buffered input

## Changing Carrier Indication Signal to J17–Pin 38

The WildCard Tables are programmed in the factory to provide Carrier Indication + and – on J17–Pins 18 and 43 as a relay contact closure output. Modify WildCard Table 8 as shown below to move the Carrier Indication signal to J17-Pin 38 as a transistor buffered output.

MOTOROLA RADIO SERVICE SOFTWARE BASE STATION PRODUCTS VER:XX.XX.XX :WILD CARD: STATE/ACTION CONFIG					Enter a Description of the State Condition																																	
Description: RD STAT		TABLE 8 OF 10			Jump to Table 8																																	
STATE and CONDITION SETTINGS																																						
State	Cond	State	Cond	State																																		
RX QUAL MET																																						
ACTION: — SET OUTPUT				3	IN ACTION: — CLR OUTPUT				3																													
—					—																																	
—					—																																	
—					—																																	
—					—																																	
—					—																																	
<table border="1" style="width: 100%; border-collapse: collapse; text-align: center;"> <tr> <td style="padding: 2px;">F1</td> <td style="padding: 2px;">F2</td> <td style="padding: 2px;">F3</td> <td style="padding: 2px;">F4</td> <td style="padding: 2px;">F5</td> <td style="padding: 2px;">F6</td> <td style="padding: 2px;">F7</td> <td style="padding: 2px;">F8</td> <td style="padding: 2px;">F9</td> <td style="padding: 2px;">F10</td> </tr> <tr> <td style="padding: 2px;">HELP</td> <td style="padding: 2px;">CHOICE</td> <td style="padding: 2px;">ADD</td> <td style="padding: 2px;">SET TO</td> <td style="padding: 2px;">PREV</td> <td style="padding: 2px;">NEXT</td> <td style="padding: 2px;">DEL</td> <td style="padding: 2px;">PROGRAMMING</td> <td style="padding: 2px;">ADDT'L</td> <td style="padding: 2px;">EXIT</td> </tr> <tr> <td></td> <td style="padding: 2px;">LIST</td> <td style="padding: 2px;">TABLE</td> <td style="padding: 2px;">DEFAULT</td> <td style="padding: 2px;">TABLE</td> <td style="padding: 2px;">TABLE</td> <td style="padding: 2px;">TABLE</td> <td style="padding: 2px;">RULES</td> <td style="padding: 2px;">CMDS</td> <td></td> </tr> </table>									F1	F2	F3	F4	F5	F6	F7	F8	F9	F10	HELP	CHOICE	ADD	SET TO	PREV	NEXT	DEL	PROGRAMMING	ADDT'L	EXIT		LIST	TABLE	DEFAULT	TABLE	TABLE	TABLE	RULES	CMDS	
F1	F2	F3	F4	F5	F6	F7	F8	F9	F10																													
HELP	CHOICE	ADD	SET TO	PREV	NEXT	DEL	PROGRAMMING	ADDT'L	EXIT																													
	LIST	TABLE	DEFAULT	TABLE	TABLE	TABLE	RULES	CMDS																														

Change from 7 to 3



**Routing Aux RX Audio to J17-Pin 30**

Edit (or add) WildCard Table 9 in order to route the Aux RX Audio signal to J17-Pin 30.

MOTOROLA RADIO SERVICE SOFTWARE BASE STATION PRODUCTS VER:XX.XX.XX :WILD CARD: STATE/ACTION CONFIG	Enter a Description of the State Condition
Description: ENABLE RX AUDIO TABLE 9 OF 10 <span style="float: right;">Jump to Table 9</span>	
STATE and CONDITION SETTINGS	
State                      Cond                      State                      Cond                      State	
COLD RESET            OR                      WARM RESET	
ACTION:	INACTION:
— RX DSC—AUXRX ON	— NULL
—	—
—	—
—	—
—	—
—	—

Program as shown

<b>F1</b>	<b>F2</b>	<b>F3</b>	<b>F4</b>	<b>F5</b>	<b>F6</b>	<b>F7</b>	<b>F8</b>	<b>F9</b>	<b>F10</b>
HELP	CHOICE	ADD	SET TO	PREV	NEXT	DEL	PROGRAMMING	ADDTL	EXIT
	LIST	TABLE	DEFAULT	TABLE	TABLE	TABLE	RULES	CMDS	





# SERIAL INTERFACE SPECIFICATIONS

For *Quantar* and *Quantro* Stations and  
*ASTRO-TAC* Receivers

(For Interface Protocol Version 01.01.01)

## 1 OVERVIEW

This section describes how to make a serial connection from a PC (or other external device) to the *Quantar/Quantro* station or receiver, enter a special servicing mode (i.e., "RSS Mode"), and issue commands to reset the station or retrieve various station status information.

**Important!** These serial interface specifications **do not apply** to stations running ASTRO® 25 Trunking Software.

## 2 MAKING SERIAL CONNECTION TO STATION

### Equipment Required

The following hardware is required to connect serially to one of the two RSS ports (one located on the SCM front panel, the other located on the station backplane):

- Personal Computer or other external control device
- 9-pin female to 9-pin male EIA-232 cable wired for null modem connections; cable is available (Motorola Part No. 30-80369E31) from Motorola Aftermarket and Accessories Division (AAD, formerly Motorola National Parts), or can be made by wiring the connectors as shown below.

**Note** A null modem adapter (9-pin male to 9-pin female) may also be used to convert a standard EIA-232 cable for connection to the RSS port. Adapters are available at most electronic supply retailers.

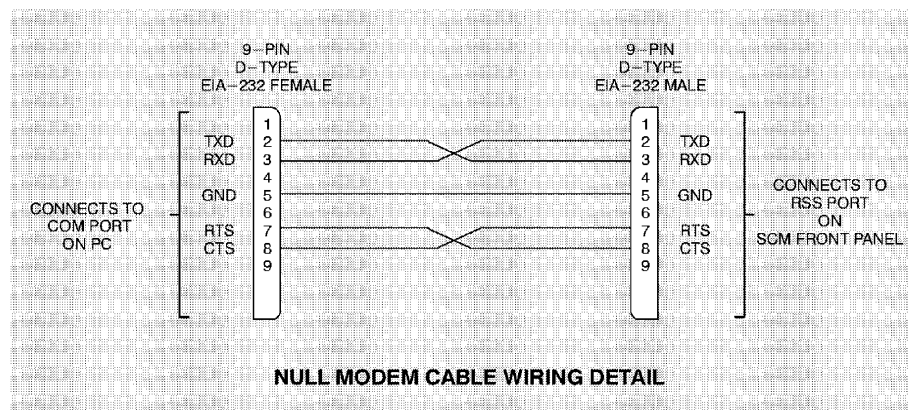

## Connecting to the Station RSS Port

Figure 1 shows a typical scenario in which a PC is connected to the RSS port on the station (SCM front panel RSS port in this illustration). The PC could be used as a simple terminal (running *Windows HyperTerminal* or similar terminal software) to allow commands to be issued manually, or it could be running third party software designed to perform automated retrieval of station operating information.

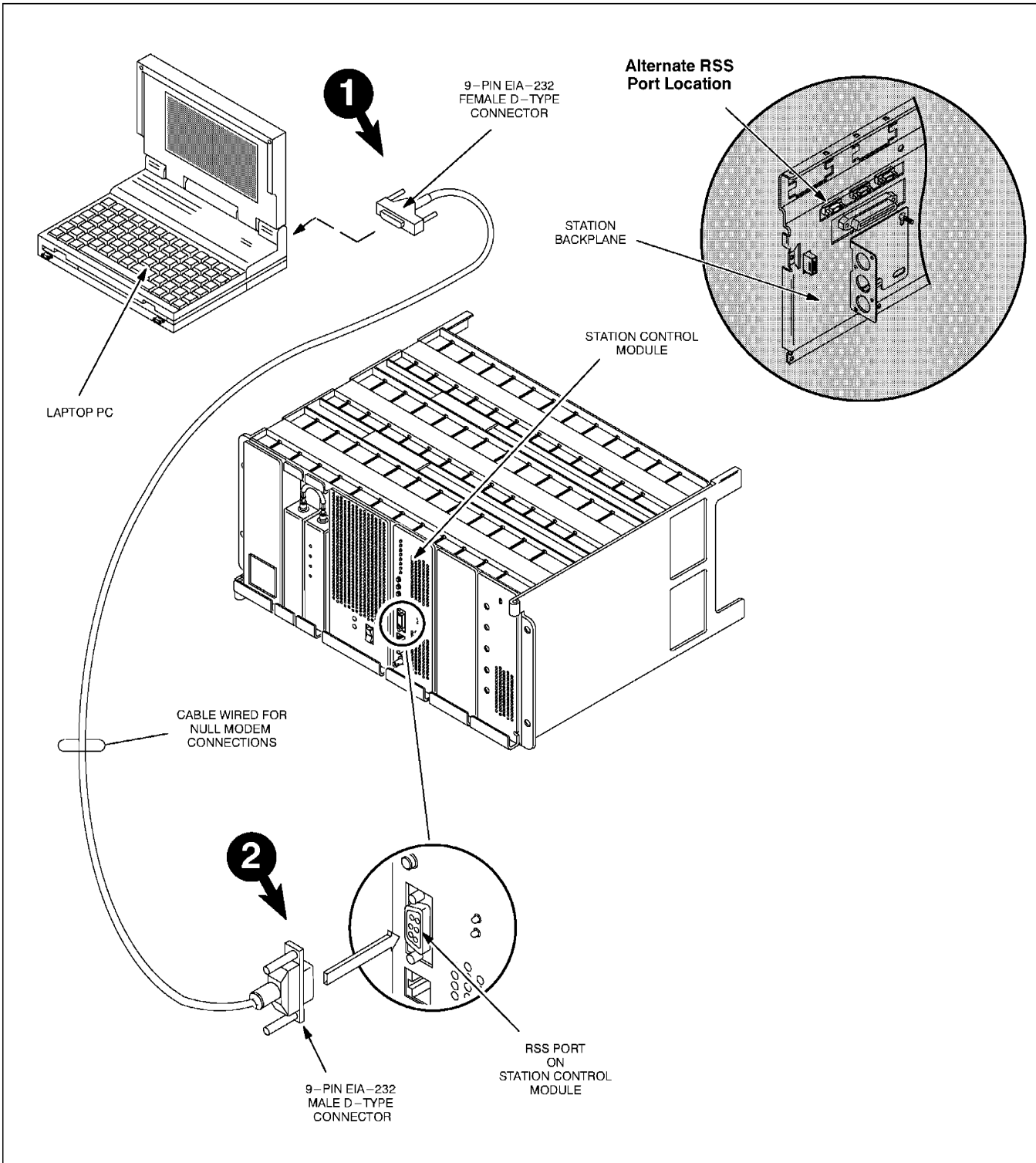

Figure 1. Connecting PC to RSS Port (Typical Scenario)

## 3 ENTERING “RSS MODE”

### Overview

In order to issue commands to the station, the station must be placed into a special operating mode called “RSS Mode.” Once in RSS Mode, you may enter commands as detailed on page 4.

**Note** *The station remains fully operational while in RSS Mode.*

### Configuring Terminal Settings

Before communicating serially with the station, you must launch and configure a terminal application running on the PC (or other external device). The primary settings are as follows:

- 9600 Baud
- No Parity
- 8 data bits
- 1 stop bit
- Flow Control set to None
- Set to appropriate Com port (typically Com1)

### Entering RSS Mode

**Step 1.** Press <ret> to obtain the station normal operating mode prompt (J-O).

**Note** Local Echo mode is on by default (following any station reset).  
To **disable** local echo, type **PCTL -ECHO OFF <cr>**  
To **enable** local echo, type **PCTL -ECHO ON <cr>**

**Step 2.** At the J-O prompt, type: **dorss <cr>**. The station will enter RSS Mode, as indicated by the **RSS:** prompt.

**Step 3.** The station is now ready to receive commands as described on page 4.



# 4 SUPPORTED COMMANDS

## Introduction

Once in RSS Mode, the station is ready to accept the following commands:

- RESET
- GET RSS\_PROTOCOL
- GET STATION\_STATUS (ALL, or 1 thru 8)
- EXIT

Each of these commands is described below, including how to interpret the results of the “GET” commands.

**Note** Be sure to read *Important Things To Know* on page 12. This section provides caveats, restrictions, and other information that affect how the commands may be used.

## RESET Command

Issuing the **RESET** command initiates a hardware reset of the station. After several seconds, the station will enter normal operating mode. This may be verified by a return of the ]-O prompt.

## GET RSS\_PROTOCOL Command

### Overview

The station software includes a serial interface kernel that determines which commands are supported and how the station responds to those commands. The serial interface kernel has a version number associated with it, which may be retrieved using the GET RSS\_PROTOCOL command.

Note that the GET RSS\_PROTOCOL command will always be accepted regardless of the particular protocol version (e.g., a third party external device designed for use with protocol version 01.01.01 will still be able to successfully issue the GET RSS\_PROTOCOL command for a station containing protocol version 02.03.02).

### Issuing the GET RSS\_PROTOCOL Command

Entering GET RSS\_PROTOCOL causes the station to report its Serial Interface Protocol Version Number. For example:

```
RSS: GET RSS_PROTOCOL
RSS: 010101fc
```

### Interpreting the Serial Interface Protocol Version Number

The protocol version number is displayed in hexadecimal format, including a checksum. The initial protocol version number is 010101fc<sub>HEX</sub>. The following illustration shows how to interpret the protocol version number following retrieval from the station.

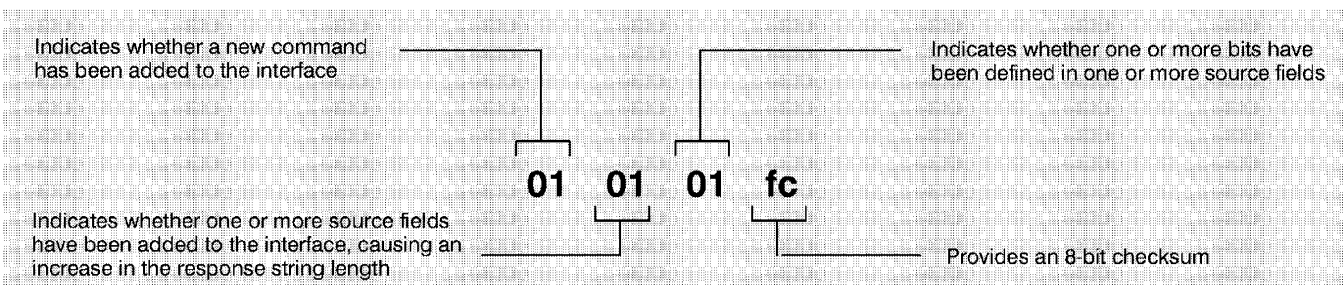

## **GET STATION\_STATUS Command**

### **Overview**

Issuing the GET STATION\_STATUS command results in a Status Response String being returned from the station. The bits in this string may be interpreted to determine various operating characteristics about the particular station.

### **Command Usage**

There are two uses of the GET STATION\_STATUS command:

- **GET STATION\_STATUS 1 thru 8** — Allows you to specify a particular status item to retrieve from the station (according to Table 1)
- **GET STATION\_STATUS ALL** — Returns status information for all eight (8) status items from the station; as shown, each Source Field (1 thru 8) along with its status field is returned in a concatenated format, with each line ending in an 8-bit checksum

The two examples shown below illustrate the structure of the Status Response Strings returned from the station for each usage type. (GET STATION\_STATUS 3 and GET STATION\_STATUS ALL are shown in this example.)

**GET STATION\_STATUS 3**

**Source Field** — Indicates the specified status item per Table 1

**Status Field** — 8 hexadecimal characters (representing 32 bits, shown below) returned from the station to indicate various status information per Table 1

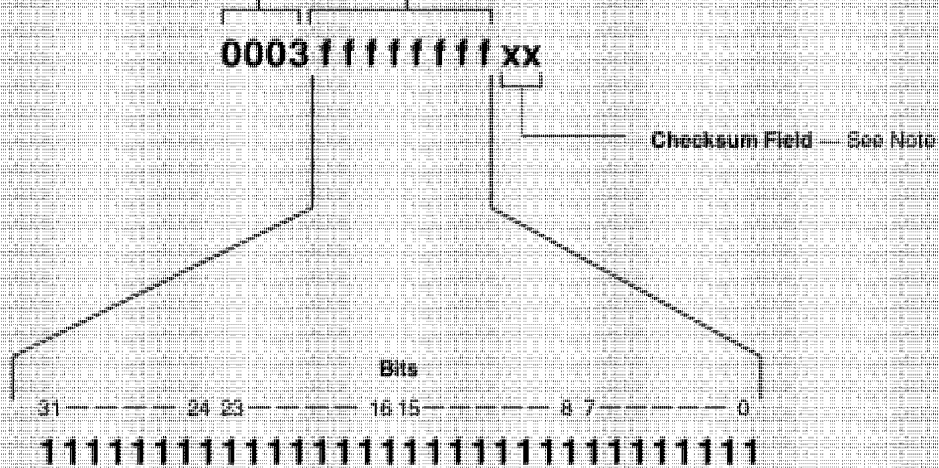

**GET STATION\_STATUS ALL**

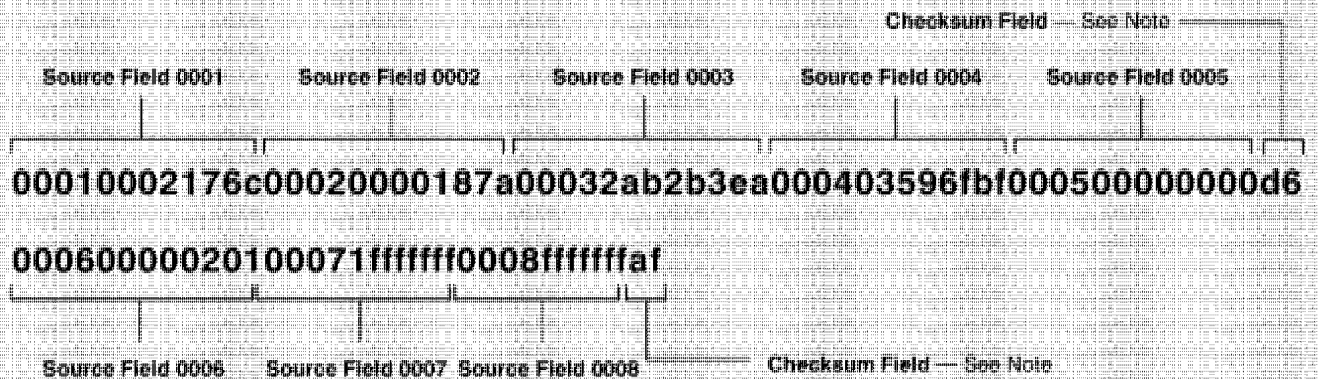

**Note** Checksums are provided at the end of each line in the Status Response String. The checksum value is generated such that adding each pair of hex digits (starting from the left and including the checksum value) results in a hex number that ends in FF. If so, the data returned from the station is considered valid.

### Interpreting the Status Response Strings

After issuing the desired command (GET STATION\_STATUS 1 thru 8 or GET STATION\_STATUS ALL), you may interpret the Status Response String returned from the station by using the information in Table 1.

**Table 1.** Interpreting Bits in Status Response String

Source Field	Status Item	Bit Descriptions		
		Bit Numbers	Parameter	Values
0000 <sub>HEX</sub>	Reserved	Reserved		
0001 <sub>HEX</sub>	Date (Following station reset, date is reset to 1/1/1900)	31 thru 22	Not Used	
		21 thru 17	Month	00001 (Jan) thru 01100 (Dec)
		16 thru 12	Day	00001 (1st) thru 11111 (31st)
		11 thru 0	Year	12-bit binary converted to decimal (e.g., 011101101100 = 1900)
0002 <sub>HEX</sub>	Time (24-Hour format)	31 thru 17	Not Used	
		16 thru 12	Hour	00000 (midnight) thru 10111 (23)
		11 thru 6	Minutes	000000 (0) thru 111010 (59)
		5 thru 0	Seconds	000000 (0) thru 111010 (59)
0003 <sub>HEX</sub>	Hardware States #1	31 – 30	External Ref (UHSO or External)	00= N/A 11 = Failure 10 = Operational
		29 – 28	Power Supply Fan	
		27 – 26	PA Fan	
		25 – 24	Receiver Module	
		23 – 22	Exciter Module	
		21 – 20	Power Supply Module	
		19 – 18	Overtoltage Alarm	00= N/A 11 = Alarm 10 = No Alarm
		17 – 16	AC State	00= N/A 11 = Failure 10 = Operational
		15 – 14	Wireline Module Failure	00= N/A 11 = Failure 10 = Operational
13 – 12	Wireline Module Status	00= N/A 11 = On 10 = Off		
continued on next page				

Source Field	Status Item	Bit Descriptions		
		Bit Numbers	Parameter	Values
0003 <sub>HEX</sub>	Hardware States #1	11 – 10	Receiver Module #2 Lock	00= N/A 11 = Locked 10 = Out of Lock
		9 – 8	Receiver Module #1 Lock	00= N/A 11 = Locked 10 = Out of Lock
		7 – 6	Exciter Module Lock	00= N/A 11 = Locked 10 = Out of Lock
		5 – 4	PA Keyed and at Expected Output Power (As set via RSS)	00= N/A 11 = Keyed and Expected Output 10 = Not Keyed or Keyed and not at Expected Output
		3 – 2	PA Output Less than Expected (As set via RSS)	00= N/A 11 = PA Keyed and Less than Expected Output 10 = PA Not Keyed or PA Keyed and at Expected Output
		1 – 0	PA Output Status	00= N/A 11 = Keyed and No Output 10 = PA Output at Expected Level
0004 <sub>HEX</sub>	Software States #1	31 – 27	Not Used	
		26	Secure (12 Kilobits) Station Type	0 = Not Secure 1 = Secure
		25	ASTRO Station Type	0 = Not ASTRO 1 = ASTRO
		24	Analog Station Type	0 = Not Analog 1 = Analog
		23	Trunked System Type	0 = Not Trunked 1 = Trunked (IR or 6809)
		22 – 21	Analog Wireline Link Status	00 = N/A 10 = Failure 11 = Operational
		20 – 19	Digital Wireline Link Status	00= N/A 10 = Failure 11 = Operational
		18 – 17	Rx Activity	00 = None 01 = Analog 10 = ASTRO 11 = SECURENET
continued on next page				

Source Field	Status Item	Bit Descriptions		
		Bit Numbers	Parameter	Values
0004 <sub>HEX</sub>	Software States #1	16 – 15	Tx Inhibit	00 = N/A 10 = Tx Enabled 11 = Tx Inhibited
		14 – 13	Intercom	00 = N/A 10 = Enabled 11 = Inhibited
		12	Access Disable Status	0 = Station Enabled 1 = Access Disabled
		11 – 10	Selective Alarms	00 = N/A 11 = Enabled 10 = Disabled
		9 – 8	Station Alarms	00 = N/A 11 = Enabled 10 = Disabled
		7 – 6	Station Disable	00 = N/A 11 = Disabled 10 = Operational
		5 – 4	Tx PL On/Off	00 = N/A 11 = On 10 = Off
		3 – 2	Rx PL On/Off	00 = N/A 11 = On 10 = Off
		1 – 0	Repeater State	00 = N/A 11 = Set Up 10 = Knocked Down
0005 <sub>HEX</sub>	Trunking States #1	31 – 8	Not Used	
		7 – 6	ISW Detect <i>(IntelliRepeater only)</i>	00 = N/A 11 = Active 10 = Inactive
		5 – 4	Active Master <i>(IntelliRepeater only)</i>	00 = N/A 11 = Active 10 = Inactive
		3 – 2	Control or Voice Channel	00 = N/A 11 = Control 10 = Voice
		1 – 0	Failsoft Mode	00 = N/A 01 = Off 10 = Site Failsoft 11 = Normal

Source Field	Status Item	Bit Descriptions		
		Bit Numbers	Parameter	Values
0006 <sub>HEX</sub>	Channel Information	31 – 16	Not Used	
		15 – 8	Total Channels Configured (See note)	00000001 (1) thru 11111111 (255)
		7 – 0	Current Station Channel (See note)	00000001 (1) thru 11111111 (255)
		<b>Note</b> The station currently supports 16 maximum (Conventional) and 28 channels maximum (IntelliRepeater).		
0007 <sub>HEX</sub>	Current Measured Power	31 – 29	Not Used	
		28	Configuration	0 = Receiver only configuration 1 = Receiver/Transmitter configuration
		27 – 20	VSWR	00000001 (1) thru 11111111 (255) Divide decimal value by 10 to obtain VSWR (e.g., 00001011 reported = decimal 11; $11 \div 10 =$ VSWR of 1.1:1)
		19 – 10	Reverse Power	000000000 (0) thru 111111111 (1023) Multiply decimal value by .01961 to obtain value in Watts (e.g., 0000100101 reported = 37 decimal; $37 \times .01961 = .725$ Watts)
		9 – 0	Forward Power	000000000 (0) thru 111111111 (1023) Multiply decimal value by .01961 to obtain value in Watts (e.g., 1101000101 reported = 937 decimal; $937 \times .01961 = 18.37$ Watts)
0008 <sub>HEX</sub>	Stored Measured Power	Same as <i>Current Measured Power</i> (above) except values apply to last previous transmitter keyup.  <b>Note</b> Upon station reset, values for Reverse Power and Forward Power will default to maximum values, indicating that the station has not been keyed up since the last reset.		

## 5 IMPORTANT THINGS TO KNOW

- Each time the station is keyed for a minimum of 400 msec, Forward Power, Reverse Power, and VSWR are measured and stored.
- When issuing commands to a Quantar Receiver, maximum values are returned for all transmit power measurements, indicating that the measurement values are not applicable (since no transmitter is present in a receiver). Additionally, the *Configuration* bit (part of *Current Measured Power* and *Stored Measured Power* fields, as described on page 11) is set to **0**, indicating that the values are not applicable.
- All messages between an external device (e.g., PC) and the station must be transmitted as ASCII strings at 9600 bps.
- A command is defined as an ASCII string terminated by a carriage return.
- The station allows a maximum rate of one command per second in order to minimize the usage of the CPU.
- The station processes only one command at a time.
- Stations/Receivers must be running software release R10.05 or higher in order to support the serial communications protocol described in this manual.
- If station is in *Configuration Mode* (a failure mode in which the codplug is typically corrupted), the normal prompt (**J-O**) will appear and the **Fail** LED on the station will be lit. Reset and Exit commands continue to work normally, but issuing any other command (e.g., GET STATION\_STATUS ALL) results in a return of data that may or may not be valid.
- No future enhancements or additional functions are currently planned for this serial protocol.
- Motorola will not be held liable for any damage caused by 3rd party external devices used to communicate with the station using the serial interface protocol.



## Manual Revision

### QUANTAR™ Instruction Manual for: *Quantar*™ Digital-Capable Station for Conventional, *SECURENET*, *ASTRO*®, 6809 Trunking, and *IntelliRepeater* Systems

This SMR applies to manual revision 68P81095E05-D. The following changes will be included in the next printing of the manual:

- The humidity specification on page 3 of the Installation section should be changed from “95% relative humidity” to “95% relative humidity, non-condensing.”
- The following disposal guidelines are now applicable to the equipment:

#### European Union (EU) Waste of Electrical and Electronic Equipment (WEEE) directive



The European Union's WEEE directive requires that products sold into EU countries must have the crossed out trashbin label on the product (or the package in some cases). As defined by the WEEE directive, this cross-out trashbin label means that customers and end-users in EU countries should not dispose of electronic and electrical equipment or accessories in household waste. Customers or end-users in EU countries should contact their local equipment supplier representative or service centre for information about the waste collection system in their country.

# Manual Revision

## **QUANTAR™ Instruction Manual for: *Quantar*™ Digital-Capable Station for Conventional, *SECURENET*, *ASTRO*®, 6809 Trunking, and *IntelliRepeater* Systems**

This SMR applies to manual revision 68P81095E05-D, Power Amplifier Module section 68P81086E23-B, behind the “Transmitter Circuitry” tab. The changes described in this SMR will be included in the next update of the manual. This revision contains information on new Power Amplifier Modules released since the manual was printed in March 2004.

The 125W VHF Power Amplifier Module models TLD3101G and TLD3102G have been replaced by new 125W VHF Power Amplifier Module models CLD1298A and CLD1299A, respectively. The new modules are functionally identical to the assemblies they replace.

The TLD3101G and TLD3102G modules are no longer available and have been replaced by the CLD1298A and CLD1299A modules.

Replace section 68P81086E23-B behind the “Transmitter Circuitry” tab in your manual with the attached new section 68P81086E23-C.



# POWER AMPLIFIER MODULE

MODELS: TLD3110A (25W, 132 - 174 MHz)  
CLD1298 (125W, 132 - 154 MHz)  
CLD1299 (125W, 150 - 174 MHz)

---

---

## 1 DESCRIPTION

The Models TLD3110 and CLD1298/CLD1299 Power Amplifier Modules are described in this section. A general description, identification of controls, indicators, and inputs/outputs, functional block diagrams, and functional theory of operation are provided. The information provided is sufficient to give service personnel a functional understanding of the module, allowing maintenance and troubleshooting to the module level. (Refer also to the Maintenance and Troubleshooting section of this manual for detailed troubleshooting procedures for all modules in the station.)

---

### General Description

The Power Amplifier Module (PA) accepts a low-level modulated rf signal from the Exciter Module and amplifies the signal for transmission via the site transmit antenna. The output power is continually monitored and regulated by a feedback and control loop, with a power output control voltage being generated by the transmitter control circuitry located in the Exciter Module.

The Models TLD3110 and CLD1298/CLD1299 PA Modules are very similar in design and function, with the major differences being the output power capabilities and operating frequency range. Unless otherwise noted, the information provided in this section applies to all three models.

---

### Overview of Circuitry

The PA contains the following circuitry:

- Intermediate Power Amplifier (IPA) – contained in 25W PA only. Low-level amplifier stage which is controlled by the transmitter control voltage from the Exciter Module; provides an output of approximately 0 to 10W
- Driver Power Amplifier (DPA) – contained in 25W PA only, provides final amplification of the IPA output; provides an output of 35W maximum
- Final Power Amplifier (FPA) – contained in 125W PA only, provides final amplification of the exciter output; provides an output of 160W maximum. All the rf amplifying transistors are included on this final module.

- Circulator – provides PA module output isolation
- Harmonic Filter/Coupler – suppresses harmonic radiation and couples the PA output to the transmit antenna connector; also serves as a power meter
- Sense and Detect Circuitry – provides sense and detect signals for critical signal points throughout the circuitry; signals are monitored by the Exciter Module

## 2 CONTROLS, INDICATORS, AND INPUTS/OUTPUTS

Figure 1 shows the PA controls, indicators, and all input and output external connections.

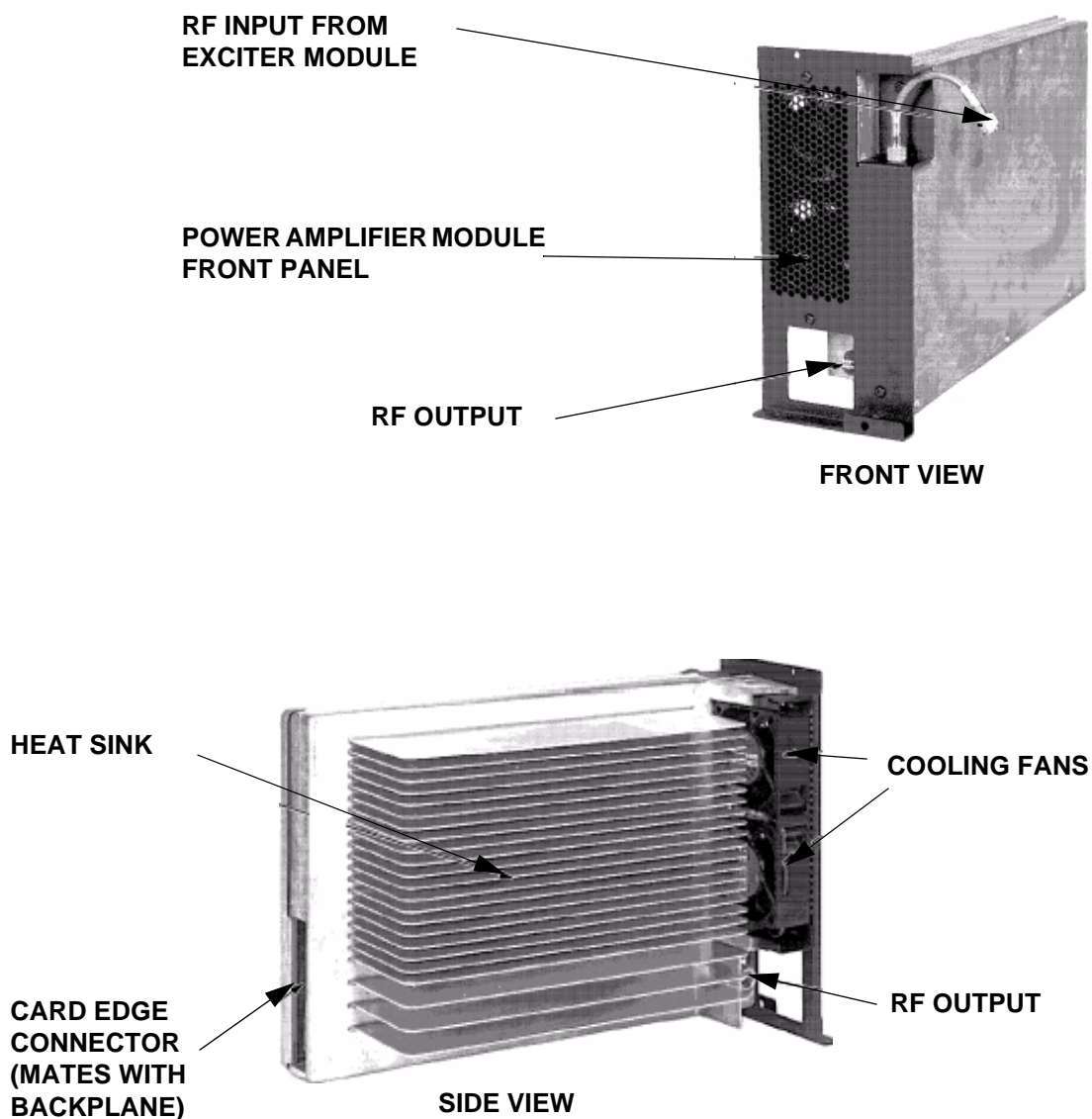

**Figure 1** Power Amplifier Module Controls, Indicators, and Inputs/Outputs (125 W Model Shown)

---

## 3 FUNCTIONAL THEORY OF OPERATION

The following theory of operation describes the operation of the PA circuitry at a functional level. The information is presented to give the service technician a basic understanding of the functions performed by the module in order to facilitate maintenance and troubleshooting to the module level. Functional block diagrams are provided in Figure 2 (TLD3110, 25 W) and Figure 3 (CLD1298/CLD1299, 125 W). As mentioned previously, the three PA modules are similar in design and function. The following theory of operation applies to all four modules except where noted.

---

### RF Signal Path

A low-level modulated rf signal (approximately +13 dBm) from the Exciter module is input to the PA module via a coax cable. For the 25W PA, the signal is input to the IPA and amplified to approximately 0 to 10W [depending on the dc power control voltage (V\_CONT) from the Exciter Module]. The IPA output is fed to a DPA (25W), where final amplification occurs. The output of the DPA (35W maximum) is fed to a circulator, which passes the transmit signal to the harmonic filter/coupler, while routing all reflected power to a 50Ω load.

For the 125W PA, the exciter output signal is fed to the Final Module and is amplified up to 160W [depending on the dc power control voltage (V\_CONT) from the Exciter Module] The output of the Final Module is fed to a circulator.

The output of the circulator is fed to the harmonic filter/coupler. This circuit provides highly selective bandpass filtering and couples the signal to an N-type connector mounted to the module casting. A coax cable routes the signal to an N-type connector mounted on an rf input/output connector bracket located on the rear of the station.

---

### Output Power Control

A feedback and control loop configuration is used to regulate the PA output power. The Harmonic Filter/Coupler generates a dc voltage proportional to the PA Module output power. This voltage (TX\_VF) is fed to the TX Power Control Circuitry in the Exciter Module. The TX\_VF voltage is compared to reference voltages to generate a dc power control voltage (V\_CONT).

**Note:** V\_OMNI does not control the output level of the DPA directly, but serves as on/off control for the DPA stage.

The dc power control voltage (V\_CONT) is output from the Exciter Module and fed through filtering circuitry in the PA to a voltage translation and current limiting circuit. The output of this circuitry is V\_OMNI, a dc voltage which controls the output power of the IPA.

### ***Summary of Power Control Operation***

**25W**—By controlling the output level of the IPA (range of 0 to 10W), the output power of the PA module is established. The feedback and control loop (TX\_VF fed back to Exciter Module resulting in V\_CONT to control IPA output) continually monitors and maintains the proper output power from the PA.

**125W**—The output power of the PA is established by controlling the gain of the first two stages of the three-stage Final Module. Here also, the feedback and control loop continually monitors and maintains the proper output power for the PA.

---

## **Sense and Detect Circuitry**

### ***Introduction***

The PA is equipped with several sense and detect circuits to provide status signals to the Exciter Module. In most cases, the Exciter Module microprocessor uses these signals to determine PA operating conditions and, in response, varies certain control signals to correct output power, turn on cooling fans, etc. The sense and detect circuits are described in the following paragraphs.

### ***Current Sensing Circuitry (25W)***

IPA and DPA current sense circuitry (comprised of two differential amplifiers and two sensing resistors) meters the current being drawn by the IPA and the DPA and outputs two dc signals directly proportional to the IPA and DPA currents. Circuit operation is described in the following paragraph.

In each of the current sense circuits, a differential amplifier measures the voltage drop across a sensing resistor and outputs a dc voltage directly proportional to the current through the resistor. The dc voltage (IPA\_I or DPA\_I) is fed to the Exciter Module (via an analog multiplexer and filtering circuitry) where it is used in calculating the current being drawn by the IPA or DPA.

### ***Current Sensing Circuitry (125 W)***

FPA current sense circuitry (comprised of two differential amplifiers and two sensing resistors) meters the current being drawn by the FPA (side A and side B) and outputs two dc signals directly proportional to the currents for side A and side B. Circuit operation is described in the following paragraph.

---

## Sense and Detect Circuitry (Continued)

In each of the current sense circuits, a differential amplifier measures the voltage drop across a sensing resistor and outputs a dc voltage directly proportional to the current through the resistor. The dc voltages (FPA\_I1\_A and FPA\_I1\_B) are fed to the Exciter Module (via an analog multiplexer and filtering circuitry) where it is used in calculating the current being drawn by the FPA (side A or side B).

### ***PA Temperature Sense***

A thermistor and buffer circuit provides a dc voltage proportional to the PA temperature. This signal (PA\_TEMP) is fed to the Exciter Module, which monitors the signal and reduces the PA output power [by reducing the dc power control voltage (V\_CONT)] if the PA temperature exceeds set limits.

### ***IPA, DPA, and FPA Detect Circuitry***

Detection circuits provide a dc voltage approximately proportional to the rf outputs of the IPA, DPA (25W), and FPA (125W) stages. These dc signals (IPA\_VF, DPA\_VF, and FPA\_VF, used for diagnostic purposes only) are fed to the Exciter Module via an analog multiplexer and filter circuitry.

### ***Reflected Power Detect Circuitry***

The Harmonic Filter/Coupler provides a dc voltage approximately proportional to the reflected power at the output of the stage. This dc signal (TX\_VR) is fed to the Exciter Module via an analog multiplexer and filter circuitry. The signal indicates the amount of potentially harmful reflected power at the PA output. If the reflected power exceeds a set limit, the Exciter Module will shut down the PA.

### ***V\_OMNI Detect Circuitry***

A voltage divider circuit provides a dc voltage approximately proportional to the V\_OMNI control voltage from the Voltage Translator & Current Limiter circuit. This dc signal (V\_OMNI\*) is fed to the Exciter Module via an analog multiplexer and filter circuitry.

### ***+74V Detect Circuitry***

A voltage divider circuit provides a dc voltage approximately proportional to the +14V dc input voltage from the station Power Supply Module. This dc signal (1 4.2V\_REF\*) is fed to the Exciter Module via an analog multiplexer and filter circuitry.

### ***+28V Detect Circuitry (125W Only)***

A voltage divider circuit provides a dc voltage approximately proportional to the +28 V dc input voltage from the station Power Supply Module. This dc signal (28V\_REF\*) is fed to the Exciter Module via an analog multiplexer and filter circuitry.

---

### Cooling Fans Control Circuitry (125 W Models Only)

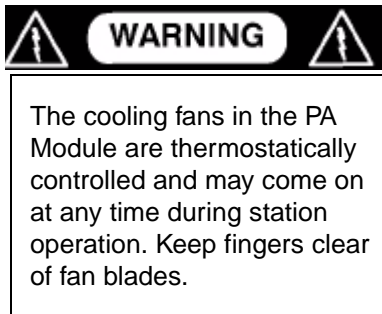

The PA is equipped with a dual fan module to provide forced air cooling of the PA. The fan module is controlled by a FAN ON signal from the Exciter Module, which is fed to a driver circuit in the PA Module. The Fan Driver/Detect Circuitry controls the power to the fans via two feed-thru pins in the PA chassis which mate with the power connector on the slide-in fan module. The fans are turned on only when the temperature in the PA exceeds a set limit. It is normal for the fans to cycle on and off during station operation.

The Fan Driver/Detect Circuitry also monitors the current to the fans and feeds a dc detect voltage to the Fan Status Circuitry, which outputs a status signal indicating whether the fan current is above or below a predetermined range. The status signal (FAN\_ALARM) is fed to the Exciter Module via an analog multiplexer and filter circuitry.

---

### Power Amplifier ID Resistor ROM

A resistor network read-only memory (ROM) provides power amplifier ID information to the Exciter Module via an analog multiplexer and filter circuits. This information includes the band and range in which the PA is designed to operate (e.g., VHF-Range 1, UHF, 900 MHz, etc.) and the maximum output power (e.g., 25 W, 125 W, etc.).



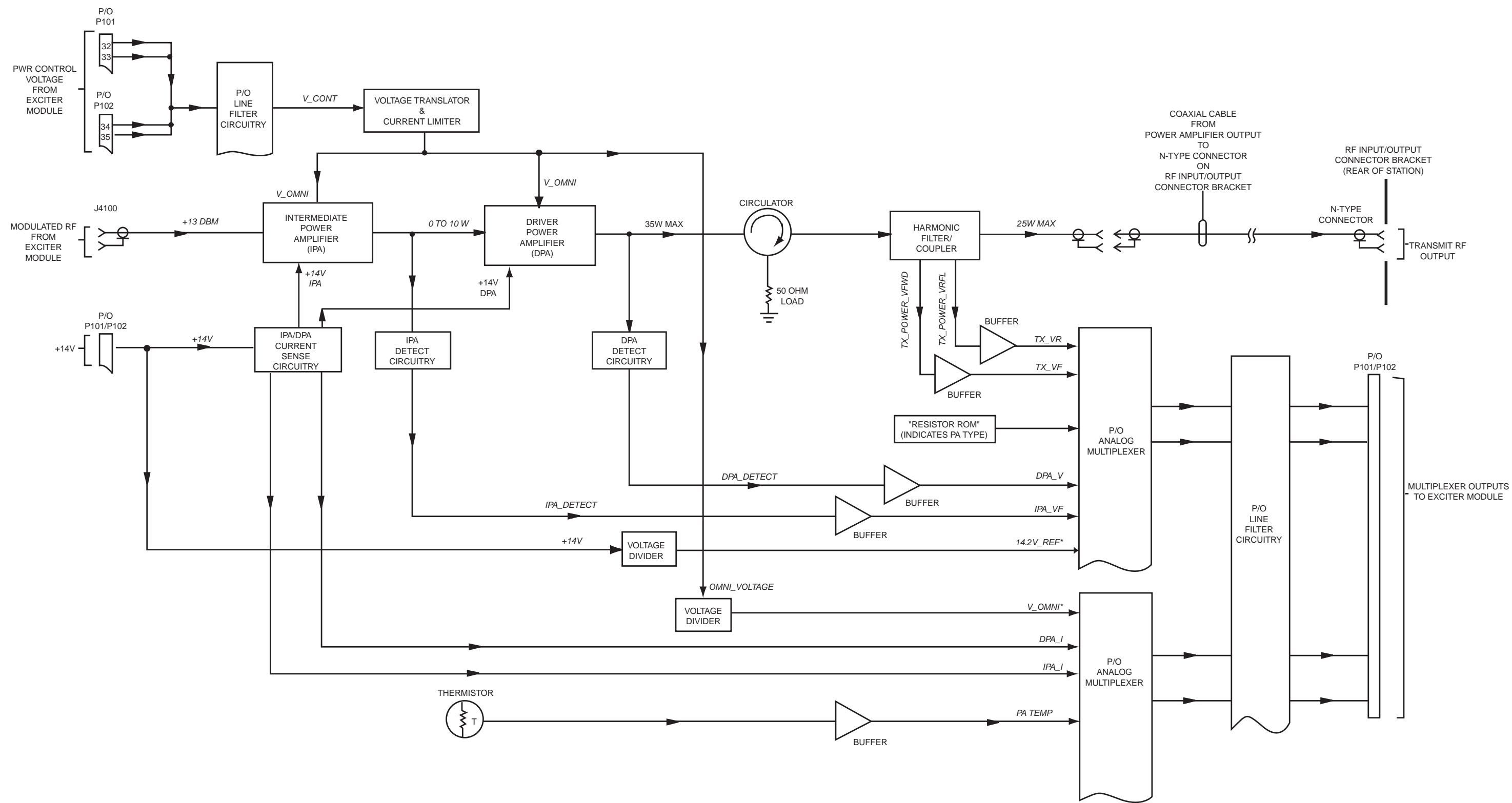

Figure 2 TLD3110 25W Power Amplifier Module Functional Block Diagram

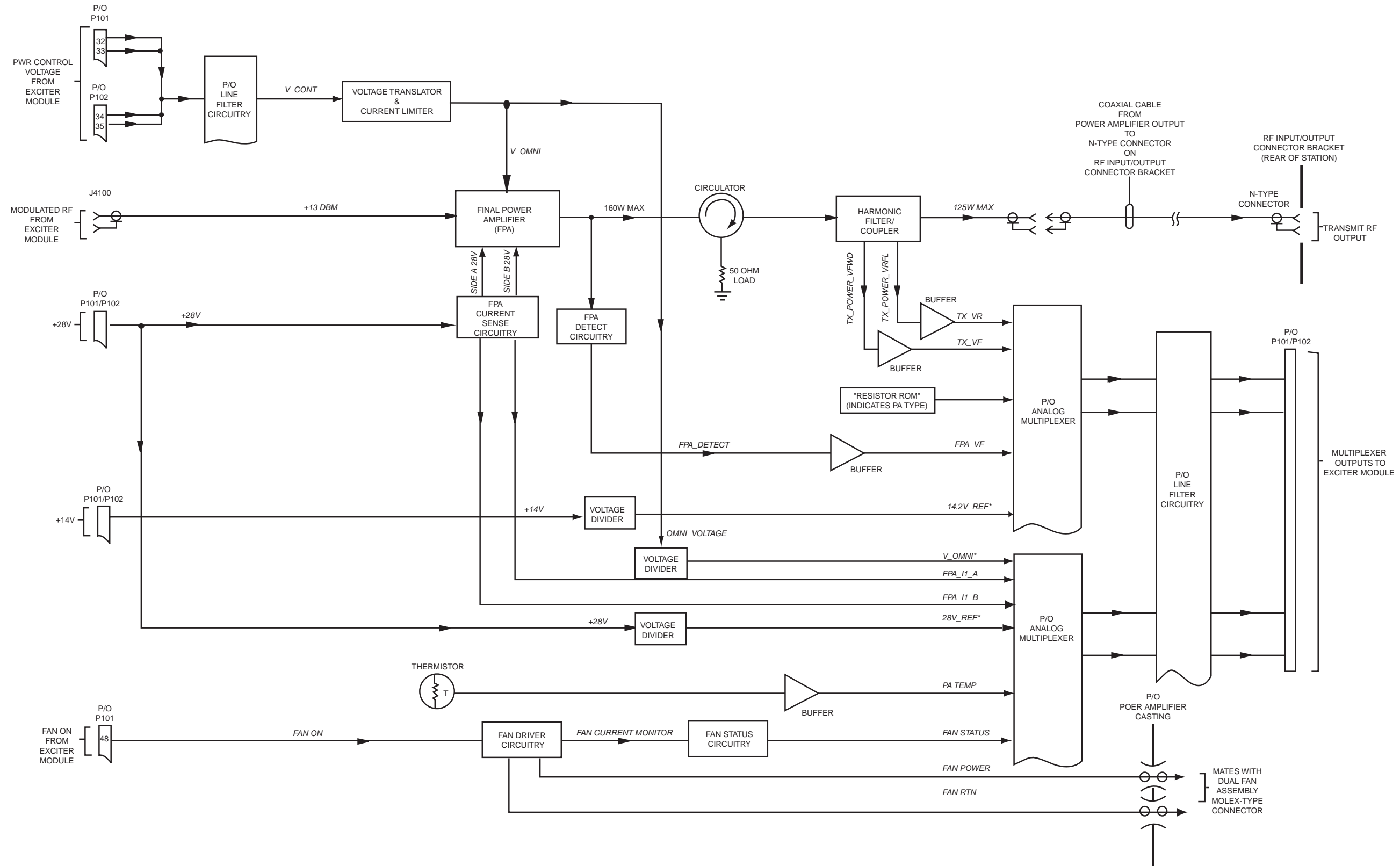

Figure 3 CLD129A8/CLD1299A 125W Power Amplifier Module Functional Block Diagram

# Manual Revision

## QUANTAR™ Instruction Manuals

This SMR applies to two instruction manuals listed below. The changes described in this SMR will be included in the next update of the manuals. This revision contains information on new control modules released since the manuals were last printed.

### 68P81095E05-D

## **Quantar™ Digital-Capable Station for Conventional, *SECURENET*, ASTRO®**, 6809 Trunking, and *IntelliRepeater* Systems

Station control modules CLN6960 and CLN1614 have been replaced by new model CLN8426A. Station control module CLN6961 has been replaced by new model CLN8447A. The new modules are functionally identical to the assemblies they replace.

If you have this manual, please make the following changes:

#### **Table of Contents:**

- Replace with the updated Table of Contents section included in this SMR (section **68P81095E05D**, dated 12/01/2007)

#### **DESCRIPTION Tab:**

- Replace pages 9, 10, and 11 in Section 68P81096E56-B with the new pages 9, 10, and 11 included with this SMR.

#### **MAINTENANCE AND TROUBLESHOOTING Tab:**

- Replace pages 27–32 in Section 68P81096E59-C with the new pages 27–32 included with this SMR.

#### **STATION CONTROL CIRCUITRY Tab:**

- Replace section 68P81094E76-C behind the “Station Control Circuitry” tab in your manual with the attached new section 68P81094E76-D.
- Remove and discard the section 68P81096E87-A for the CLN1614 SCM; this module is no longer available.

# **68P81094E85-O**

## **ASTRO-TAC™ Receiver For Analog/ASTRO® and Analog/SECURENET Systems**

Station control modules TTN4094A/B and TRN7900A/B have been replaced by new models CLN8426A and CLN8447A. The new modules are functionally identical to the assemblies they replace.

If you have this manual, please make the following changes:

### **DESCRIPTION Tab:**

- The following paragraph replaces the “Introduction” paragraph on page 6:  
The Station Control Module (SCM) is the microprocessor – based controller for the station. Major components include an MC68360 microprocessor, a 56311 Digital Signal Processor (DSP), and two programmable devices, a CPLD for the host and a FPGA for the DSP. The SCM operates as follows:
- Replace all occurrences of “DSP ASIC” with “DSP FPGA”. The SCM now uses a field-programmable gate array (FPGA) instead of an application-specific IC (ASIC).

### **STATION CONTROL CIRCUITRY Tab:**

- Replace section **68P81090E94-O** behind the “Station Control Circuitry” tab in your manual with the attached new section **68P81094E76-D**.

**The remaining pages of this SMR are not needed for 68P81094E85-O and may be discarded.**



**QUANTAR<sup>®</sup>**

## **Digital - Capable Station**

For Conventional, SECURENET, ASTRO,  
6809 Trunking, and *Intellirepeater* Systems

VHF - 25W & 125W

UHF - 25W, 100W & 110W

800 MHz - 20W & 100W

900 MHz - 100W



**Instruction Manual**

68P81095E05-D

## Computer Software Copyrights

The Motorola products described in this document include a copyrighted Motorola computer program. Laws in the United States and other countries, as well as International Treaties, preserve for Motorola the exclusive rights for Motorola's copyrighted computer programs, including the exclusive right to copy, reproduce, distribute, or otherwise transfer said computer program(s). Accordingly, the copyrighted Motorola computer programs contained in this document may not be copied, decompiled, reverse engineered, or reproduced in any manner and on or within any media without the express written permission of Motorola. Furthermore, the purchase of Motorola products shall not be deemed to grant either directly or by implication, estoppel, or otherwise, any license under the copyrights, patents, or patent applications of Motorola, except for the normal non-exclusive, royalty-free license to use that arises by operation of law in the sale of a product.

## Document Copyrights

© Motorola, Inc. All rights reserved.

No duplication or distribution of this document or any portion thereof shall take place without the express written permission of Motorola. No part of this document may be reproduced, distributed, or transmitted in any form or by any means, electronic or mechanical, for any purpose without the express written permission of Motorola.

To order additional copies of this document contact your Motorola sales representative.

## Disclaimer

The information in this document is carefully examined, and is believed to be entirely reliable. However, no responsibility is assumed for inaccuracies. Furthermore, Motorola reserves the right to make changes to any products herein to improve readability, function, or design. Motorola does not assume any liability arising out of the applications or use of any product or circuit described herein; neither does it cover any license under its patent rights nor the rights of others.

## Trademark Information

The following are registered trademarks of Motorola, Inc.: Motorola, the Motorola logo, ASTRO, ASTRO-TAC, EMBASSY, FullVision, INTELLIREPEATER, QUANTAR, QUANTRO, and SMARTZONE.

The following are Motorola trademarks: CENTRACOM Elite, CENTRACOM Series, CENTRACOM Gold Series, MOSCAD, SECURENET, and Wireless Network Gateway.

HP, HP-UX, OpenView, Vectra, and Hewlett Packard are registered trademarks of Hewlett-Packard Corporation.

UNIX is a registered trademark of The Open Group in the United States and other countries.

Any other brand or product names are trademarks or registered trademarks of their respective holders.

## WARRANTY

### Limited Software Warranty

For the first ninety (90) days following its initial shipment, Motorola warrants that when properly used, its software will be free from reproducible defects that cause a material variance from its published specification. However, Motorola does not warrant that program operation will be uninterrupted or error-free, that each defect will be corrected, or that any program will meet Licensee's particular requirements.

This warranty does not cover an item of Software (i) used in other than its normal and customary manner; (ii) subjected to misuse; or (iii) subjected to modifications by Licensee or by any party other than Motorola without the prior written consent of Motorola.

### Limited Media Warranty

For the first ninety (90) days following its initial shipment, Motorola warrants that the media carrying the software will be free from defects that damage the performance of the software. Motorola will replace any damaged media free of charge during the warranty period. Warranted media is limited to that which is used to transport the software (such as floppy disks and authorization key). PROMs that may store the software in equipment are not covered under this warranty.

### Limitation of Liability

Motorola's total liability and Licensee's sole remedy for any warranted software shall be limited to, at Motorola's option, software replacement or the payment of Licensee's actual damages, not to exceed the total licensed charge paid by Licensee to Motorola for the item of software that caused the damage.

The warranties set forth above extend only to the first licensee. Subsequent transferees accept these programs "as is" and without warranties of any kind. **This warranty is given in lieu of all other warranties, express or implied, including, without limitation, the warranties of merchantability and fitness for a particular purpose.**

In no event shall Motorola be liable for special, incidental, or consequential damages (including, without limitation, loss of use, time or data, inconvenience, commercial loss, and lost profits or savings) to the full extent that such may be disclaimed by law even if Motorola has been advised of the possibility of such damage against licensee by any other party.

### Repair of Defects

The classification of defects in Motorola-supplied software shall be the responsibility of Motorola. Remedy of defects is at the sole discretion of Motorola. If Motorola agrees to remedy a software defect, the new software will be warranted until the end of the original limited warranty period.

Replacement of any software defect shall constitute Motorola supplying the Licensee with the appropriate software media and authorization key. Field installation and configuration are not included. Field software updates/upgrades and new enhancement option software will be warranted for ninety (90) days from the date of initial shipment.

All warranty service will be performed at service locations designated by Motorola. Travel and associated expenses of the Licensee or such expenses incurred by Motorola for visits to Licensee's location by Motorola personnel are not covered by this warranty.

## Table of Contents

Model/Option Information .....	xi
Foreword .....	xxiv
General Safety Information .....	xxvi
Performance Specifications .....	xxviii
<b>DESCRIPTION .....</b>	<b>68P81096E56</b>
<b>Introduction .....</b>	<b>page 1</b>
Compact Mechanical Design .....	page 1
State-of-the-Art Electrical Design .....	page 2
Summary of Operating Features .....	page 3
Multiple System Capability .....	page 4
<b>Station Components .....</b>	<b>page 6</b>
<b>Functional Theory of Operation .....</b>	<b>page 8</b>
Transmitter Circuitry Operation .....	page 5
Receiver Circuitry Operation .....	page 9
Station Control Circuitry Operation .....	page 9
Wireline Interface Board Operation .....	page 10
Power Supply Module Operation .....	page 10
<b>INSTALLATION .....</b>	<b>68P81096E57</b>
<b>Pre-Installation Considerations .....</b>	<b>page 2</b>
Installation Overview .....	page 2
Environmental Conditions at Intended Site .....	page 3
Equipment Ventilation .....	page 3
AC Input Power Requirements .....	page 4
Equipment Mounting Methods .....	page 4
Site Grounding and Lightning Protection .....	page 5
Recommended Tools and Equipment .....	page 6
Equipment Unpacking and Inspection .....	page 6
Physical Dimensions and Clearances .....	page 7
<b>Mechanical Installation .....</b>	<b>page 14</b>
Unpacking the Equipment .....	page 14
Mounting Procedures .....	page 20
Stacking Cabinets .....	page 25
Stacking Modular Racks .....	page 26
Anti-Vibration/EMI Screws .....	page 27

<b>Electrical Connections</b> .....	<b>page 28</b>
Power Supply Connections .....	page 28
RF Cabling Connections .....	page 32
Connecting System Cables .....	page 38
Connecting Telephone Lines .....	page 46
Connecting V24 Modems .....	page 50
Connecting External Reference .....	page 51
<b>Post-Installation Checkout</b> .....	<b>page 54</b>
Applying Power .....	page 54
Verifying Proper Operation .....	page 54
Proceeding to Optimization .....	page 56
<b>OPTIMIZATION</b> .....	<b>68P81086E72</b>
<b>Description</b> .....	<b>page 1</b>
<b>OPERATION</b> .....	<b>68P81096E58</b>
<b>Description</b> .....	<b>page 1</b>
Summary of Switches, Pushbuttons, and Connectors .....	page 1
Summary of LED Indicators .....	page 1

## Maintenance & Troubleshooting

<b>ROUTINE MAINTENANCE</b> .....	<b>68P81086E39</b>
<b>Introduction</b> .....	<b>page 1</b>
<b>Recommended Test Equipment</b> .....	<b>page 1</b>
<b>TROUBLESHOOTING</b> .....	<b>68P81096E59</b>
<b>Introduction</b> .....	<b>page 1</b>
<b>Recommended Test Equipment</b> .....	<b>page 1</b>
<b>Troubleshooting Procedures</b> .....	<b>page 2</b>
Troubleshooting Overview .....	page 2
Interpreting LED Indicators .....	page 6
Interpreting Alarm Alert Tones .....	page 9
Verifying Transmitter Circuitry .....	page 10
Verifying Receiver Circuitry .....	page 14
<b>Module Replacement Procedures</b> .....	<b>page 19</b>
General Replacement Information .....	page 19
Replacing Power Amplifier Module .....	page 21
Replacing Exciter Module .....	page 22
Replacing Power Supply Module .....	page 23
Replacing Station Control Module .....	page 24
Replacing Wireline Interface Board .....	page 30
Replacing Receiver Module and/or Preselector Assembly (VHF and UHF) .....	page 32
Replacing Receiver Module (800 MHz and 900 MHz) .....	page 33
Replacing ASTRO Modem Card .....	page 34
Replacing Backplane Board .....	page 35



<b>Preselector Field Tuning Procedure</b> .....	<b>page 36</b>
Required Test Equipment .....	page 36
VHF Tuning Procedure .....	page 37
UHF Tuning Procedure .....	page 40

## Station Modules

### RECEIVER CIRCUITRY

#### **RECEIVER MODULE (VHF RANGES 1 AND 2; INCLUDES PRESELECTOR)..... 68P81086E28**

<b>Description</b> .....	<b>page 1</b>
General Description .....	page 1
Overview of Circuitry .....	page 1
<b>Controls, Indicators, and Inputs/Outputs</b> .....	<b>page 2</b>
<b>Functional Theory of Operation</b> .....	<b>page 3</b>
Synthesizer and VCO Circuitry .....	page 3
Preselector Filter Assembly .....	page 4
Receiver Front End Circuitry .....	page 4
Custom Receiver IC Circuitry .....	page 4
Address Decode and A/D Converter Circuitry .....	page 5
Voltage Regulator Circuitry .....	page 5

#### **RECEIVER MODULE (UHF)..... 68P81086E48**

<b>Description</b> .....	<b>page 1</b>
General Description .....	page 1
Overview of Circuitry .....	page 1
<b>Controls, Indicators, and Inputs/Outputs</b> .....	<b>page 2</b>
<b>Functional Theory of Operation</b> .....	<b>page 3</b>
Synthesizer and VCO Circuitry .....	page 3
Preselector Filter Assembly .....	page 4
Receiver Front End Circuitry .....	page 4
Custom Receiver IC Circuitry .....	page 4
Address Decode and A/D Converter Circuitry .....	page 5
Voltage Regulator Circuitry .....	page 5

#### **RECEIVER MODULE (800 MHz) ..... 68P81086E76**

<b>Description</b> .....	<b>page 1</b>
General Description .....	page 1
Overview of Circuitry .....	page 1
<b>Controls, Indicators, and Inputs/Outputs</b> .....	<b>page 2</b>
<b>Functional Theory of Operation</b> .....	<b>page 3</b>
Synthesizer and VCO Circuitry .....	page 3
Receiver Front End Circuitry .....	page 4
Custom Receiver IC Circuitry .....	page 4
Address Decode and A/D Converter Circuitry .....	page 5
Voltage Regulator Circuitry .....	page 5

---

**RECEIVER MODULE (900 MHz) . . . . . 68P81091E92**

**Description . . . . . page 1**  
    General Description . . . . . page 1  
    Overview of Circuitry . . . . . page 1

**Controls, Indicators, and Inputs/Outputs . . . . . page 2**

**Functional Theory of Operation . . . . . page 3**  
    Synthesizer and VCO Circuitry . . . . . page 3  
    Receiver Front End Circuitry . . . . . page 4  
    Custom Receiver IC Circuitry . . . . . page 4  
    Address Decode and A/D Converter Circuitry . . . . . page 5  
    Voltage Regulator Circuitry . . . . . page 5

**TRANSMITTER CIRCUITRY**

**EXCITER BOARD (VHF, UHF, 800/900 MHz) . . . . . 68P81086E24**

**Description . . . . . page 1**  
    General Description . . . . . page 1  
    Overview of Circuitry . . . . . page 1

**Controls, Indicators, and Inputs/Outputs . . . . . page 2**

**Functional Theory of Operation . . . . . page 3**  
    Synthesizer and VCO Circuitry . . . . . page 3  
    RF Switch Circuitry . . . . . page 4  
    Microprocessor Circuitry . . . . . page 4  
    TX Power Control Circuitry . . . . . page 5

**VHF POWER AMPLIFIER MODULE (25W/125W R1 & R2). . . . . 68P81086E23**

**Description . . . . . page 1**  
    General Description . . . . . page 1  
    Overview of Circuitry . . . . . page 1

**Controls, Indicators, and Inputs/Outputs . . . . . page 2**

**Functional Theory of Operation . . . . . page 3**  
    RF Signal Path . . . . . page 3  
    Output Power Control . . . . . page 3  
    Sense and Detect Circuitry . . . . . page 4  
    Cooling Fans Control Circuitry . . . . . page 6

**UHF POWER AMPLIFIER MODULE (R0/110W; R1 & R2/25W; R1-3/110W; R4/100W) . . . . . 68P81088E44**

**Description . . . . . page 1**  
    General Description . . . . . page 1  
    Overview of Circuitry . . . . . page 1

**Controls, Indicators, and Inputs/Outputs . . . . . page 2**

**Functional Theory of Operation . . . . . page 3**  
    RF Signal Path . . . . . page 3  
    Output Power Control . . . . . page 3  
    Sense and Detect Circuitry . . . . . page 4  
    Cooling Fans Control Circuitry . . . . . page 6

---

**POWER AMPLIFIER MODULE (20W/100W 800 MHZ; 100W 900 MHZ;) 68P81091E91**

**Description . . . . . page 1**  
    General Description . . . . . Page 1  
    Overview of Circuitry . . . . . page 1

**Controls, Indicators, and Inputs/Outputs . . . . . page 2**

**Functional Theory of Operation . . . . . page 3**  
    RF Signal Path . . . . . Page 3  
    Output Power Control . . . . . Page 3  
    Sense and Detect Circuitry . . . . . page 4  
    Cooling Fans Control Circuitry . . . . . page 6

**Station Control Circuitry**

**STATION CONTROL MODULE (CLN8426/CLN8447) . . . . . 68P81094E76**

**Description . . . . . page 1**  
    General Description . . . . . page 1  
    Overview of Circuitry . . . . . page 2

**Controls, Indicators, and Inputs/Outputs . . . . . page 3**

**Functional Theory of Operation . . . . . page 4**  
    Host Microprocessor/Host ASIC Circuitry . . . . . page 4  
    Non-Volatile Memory . . . . . page 5  
    DRAM Memory . . . . . page 5  
    External Line Interface Circuitry . . . . . page 6  
    Digital Signal Processor (DSP) and DSP ASIC Circuitry . . . . . page 7  
    Station Reference Circuitry . . . . . page 8  
    HDLC Bus Control Circuitry . . . . . page 8  
    Audio Interface Circuitry . . . . . page 9  
    Input/Output Ports . . . . . page 10  
    6809/MRTI Interface Circuitry . . . . . page 10  
    Front Panel LEDs and Switches . . . . . page 11  
    Supply Voltages Circuitry . . . . . page 11

**STATION CONTROL MODULE (CLN7692) . . . . . 68P81012Y01**

**Description . . . . . page 1**  
    General Description . . . . . page 1  
    Overview of Circuitry . . . . . page 1

**Controls, Indicators, and Inputs/Outputs . . . . . page 2**

**Functional Theory of Operation . . . . . page 4**  
    Host Microprocessor/Host ASIC Circuitry . . . . . page 4  
    Non-Volatile Memory . . . . . page 5  
    SDRAM Memory . . . . . page 5  
    External Line Interface Circuitry . . . . . page 5  
    Digital Signal Processor (DSP) and DSP ASIC Circuitry . . . . . page 6  
    Station Reference Circuitry . . . . . page 8  
    HDLC Bus Control Circuitry . . . . . page 9  
    Audio Interface Circuitry . . . . . page 9  
    Input/Output Ports . . . . . page 10  
    6809/MRTI Interface Circuitry . . . . . page 11

Front Panel LEDs and Switches .....	page 11
Supply Voltages Circuitry .....	page 14

## Wireline Circuitry

<b>WIRELINE INTERFACE BOARD (4-WIRE) .....</b>	<b>68P81094E77</b>
<b>Description .....</b>	<b>page 1</b>
General Description .....	page 1
Overview of Circuitry .....	page 1
<b>Controls, Indicators, and Inputs/Outputs .....</b>	<b>page 2</b>
<b>Functional Theory of Operation .....</b>	<b>page 3</b>
Functional Overview .....	page 3
Description of Audio/Data Signal Paths .....	page 7

<b>WIRELINE INTERFACE MODULE (8-WIRE) .....</b>	<b>68P81094E78</b>
<b>Description .....</b>	<b>page 1</b>
General Description .....	page 1
Overview of Circuitry .....	page 1
<b>Controls, Indicators, and Inputs/Outputs .....</b>	<b>page 2</b>
<b>Functional Theory of Operation .....</b>	<b>page 3</b>
Functional Overview .....	page 3
Description of Audio/Data Signal Paths .....	page 7

## Station Backplane

### STATION BACKPLANE BOARD

<b>Description .....</b>	<b>page 1</b>
<b>Location of Backplane Connectors .....</b>	<b>page 2</b>
<b>Backplane Connectors Information .....</b>	<b>page 3</b>

## Station Power Supply Modules

<b>265W POWER SUPPLY MODULE (AC INPUT) .....</b>	<b>68P81096E09</b>
<b>Description .....</b>	<b>page 1</b>
General Description .....	page 1
Power Supply Module Simplified Block Diagram .....	page 2
Overview of Circuitry .....	page 3
<b>Performance Specifications .....</b>	<b>page 6</b>
<b>Controls, Indicators, and Inputs/Outputs .....</b>	<b>page 7</b>
<b>Functional Theory of Operation (AC-to-DC Converter Board) .....</b>	<b>page 8</b>
Input Conditioning Circuitry .....	page 8
Startup Delay Circuitry .....	page 8
Boost/Power Factor Correction Circuitry .....	page 9
Battery Revert Trigger Circuitry .....	page 9
VCC Supply Circuitry .....	page 9

---

LED Status Indicators . . . . .	page 10
<b>Functional Theory of Operation (DC-to-DC Converter Board) . . . . .</b>	<b>page 11</b>
+14V Main Supply Circuitry . . . . .	page 11
+5V Supply Circuitry . . . . .	page 12
Battery Charger Control Circuitry . . . . .	page 12
Reference Voltage Circuitry . . . . .	page 12
Diagnostics Circuitry . . . . .	page 13
Address Decode Circuitry . . . . .	page 13
Startup/Shutdown Control Circuitry . . . . .	page 14
<b>Functional Theory of Operation (Battery Charger/Revert Board) . . . . .</b>	<b>page 15</b>
Charger Supply Circuitry . . . . .	page 15
Pulse Width Modulator Circuitry . . . . .	page 16
Battery Revert Circuitry . . . . .	page 16
Current Mode Controller Circuitry . . . . .	page 16
SPI Bus Interface Circuitry . . . . .	page 17
Shutdown Circuitry . . . . .	page 17
Local Supplies Circuitry . . . . .	page 17
<b>625W POWER SUPPLY MODULE (ac input) . . . . .</b>	<b>68P81095E88</b>
<b>Description . . . . .</b>	<b>page 1</b>
<b>Performance Specifications . . . . .</b>	<b>page 6</b>
<b>Controls, Indicators, and Inputs/Outputs . . . . .</b>	<b>page 7</b>
<b>Functional Theory of Operation (AC-to-DC Converter Board) . . . . .</b>	<b>page 8</b>
Input Conditioning Circuitry . . . . .	page 8
Startup Delay Circuitry . . . . .	page 8
Boost/Power Factor Correction Circuitry . . . . .	page 9
Battery Revert Trigger Circuitry . . . . .	page 9
VCC Supply Circuitry . . . . .	page 9
LED Status Indicators . . . . .	page 10
<b>Functional Theory of Operation (DC-to-DC Converter Board) . . . . .</b>	<b>page 11</b>
+28V Main Supply Circuitry . . . . .	page 11
+14V Supply Circuitry . . . . .	page 12
+5V Supply Circuitry . . . . .	page 12
Battery Charger Control Circuitry . . . . .	page 13
Reference Voltage Circuitry . . . . .	page 13
Diagnostics Circuitry . . . . .	page 13
Address Decode Circuitry . . . . .	page 14
Startup/Shutdown Control Circuitry . . . . .	page 14
<b>Functional Theory of Operation (Battery Charger/Revert Board) . . . . .</b>	<b>page 15</b>
Charger Supply Circuitry . . . . .	page 15
Pulse Width Modulator Circuitry . . . . .	page 16
Battery Revert Circuitry . . . . .	page 16
Current Mode Controller Circuitry . . . . .	page 16
SPI Bus Interface Circuitry . . . . .	page 17
Shutdown Circuitry . . . . .	page 17
Local Supplies Circuitry . . . . .	page 17



---

## Ancillary Equipment

<b>ANTENNA RELAY (OPTION X371AA)</b> .....	<b>68P81086E22</b>
Description .....	page 1
Input and Output Connections .....	page 2
Option Complement .....	page 3
Performance Specifications .....	page 3
Mounting Locations .....	page 4
Functional Theory of Operation .....	page 5
<b>TRIPLE CIRCULATOR OPTIONS</b>	
<b>VHF TRIPLE CIRCULATOR OPTION (OPTIONS X676AA-AC)</b> .....	<b>68P81086E34</b>
Description .....	page 1
Options Complement .....	page 2
Performance Specifications .....	page 3
Inputs/Outputs .....	page 4
Functional Theory of Operation .....	page 5
<b>UHF TRIPLE CIRCULATOR OPTION (OPTIONS X676AN AND X676AP)</b> .....	<b>68P81088E54</b>
Description .....	page 1
Option Complement .....	page 2
Performance Specifications .....	page 3
Inputs/Outputs .....	page 4
Functional Theory of Operation .....	page 5
<b>800/900 MHz TRIPLE CIRCULATOR OPTION (OPTIONS X676AR AND X676AQ)</b> .....	<b>68P81090E86</b>
Description .....	page 1
Option Complement .....	page 2
Performance Specifications .....	page 2
Inputs/Outputs .....	page 3
Functional Theory of Operation .....	page 4

---

## DUPLEXER OPTIONS

### VHF DUPLEXERS (OPTIONS X182AA, AB, AJ) ..... 68P81086E71

Description .....	page 1
Adjustments and Inputs/Outputs .....	page 2
Performance Specifications.....	page 3
Typical Mounting Configuration .....	page 3
Field Tuning Procedure .....	page 6

### UHF DUPLEXER (OPTIONS X182AC THROUGH X182AF) ..... 68P81087E94

Description .....	page 1
Inputs/Outputs.....	page 2
Performance Specifications.....	page 3
Typical Mounting Configuration .....	page 4
Field Tuning Procedure .....	page 6
Field Tuning Overview .....	page 6
Required Test Equipment .....	page 6
Setting Up for Tuning Duplexer .....	page 7
Duplexer Tuning Procedure.....	page 8

### 800/900 MHz DUPLEXERS (OPTIONS X182AG AND X182AH) ..... 68P81091E93

Description .....	page 1
Inputs/Outputs.....	page 2
Performance Specifications.....	page 3
Typical Mounting Configuration .....	page 3

## MODEM OPTION

### ASTRO MODEM CARD (OPTION X437AA)..... 68P81086E38

Description .....	page 1
-------------------	--------

## PERIPHERAL TRAY OPTION

### PERIPHERAL TRAY (OPTION X696AA) ..... 68P81086E37

Description .....	page 1
Options Complement .....	page 2
Peripheral Tray Contents and Inputs/Outputs .....	page 3

## UHSO OPTION

### ULTRA HIGH STABILITY OSCILLATOR (UHSO; OPTION X873AA)..... 68P81088E08

Description .....	page 1
Inputs/Outputs.....	page 2
Functional Theory of Operation.....	page 3



---

# SYSTEM APPLICATIONS

<b>RA/RT CONFIGURATION (TRC CONTROL)</b> .....	<b>68P81090E98</b>
<b>Overview</b> .....	<b>page 1</b>
<b>Electrical Connections (RF Link)</b> .....	<b>page 2</b>
Console to Station 1 Wiring Connections .....	page 2
Station 2 to Station 3 Wiring Connections .....	page 3
<b>Electrical Connections (Microwave Link)</b> .....	<b>page 4</b>
Console to Microwave Station 1 Wiring Connections .....	page 4
Microwave Station 2 to Station 3 Wiring Connections .....	Page 5
<b>RSS Programming</b> .....	<b>page 6</b>
<b>TX Wireline Alignment</b> .....	<b>page 7</b>
Station 1 TX Wireline Alignment .....	page 7
Station 2 TX Wireline Alignment .....	page 7
Station 3 TX Wireline Alignment .....	page 8
<b>RA/RT CONFIGURATION (E &amp; M KEYING)</b> .....	<b>68P81090E99</b>
<b>Overview</b> .....	<b>page 1</b>
<b>Electrical Connections (RF Link)</b> .....	<b>page 2</b>
Console to Station 1 Wiring Connections .....	page 2
Station 2 to Station 3 Wiring Connections .....	page 3
<b>Electrical Connections (Microwave Link)</b> .....	<b>page 5</b>
Console to Microwave Station 1 Wiring Connections .....	page 5
Microwave Station 2 to Station 3 wiring Connections .....	page 6
<b>RSS Programming</b> .....	<b>page 8</b>
<b>TX Wireline Alignment</b> .....	<b>page 9</b>
Station 1 TX Wireline Alignment .....	page 9
Station 2 TX Wireline Alignment .....	page 9
Station 3 TX Wireline Alignment .....	page 10
<b>FALL BACK IN-CABINET REPEAT FEATURE</b> .....	<b>68P81095E96</b>
<b>Overview</b> .....	<b>page 1</b>
<b>Configuring the FBICR Feature</b> .....	<b>page 4</b>
<b>MAIN/STANDBY CONFIGURATION</b> .....	<b>68P81095E89</b>
<b>Overview</b> .....	<b>page 1</b>
<b>Electrical Connections</b> .....	<b>page 2</b>
<b>Setting Wireline Impedance Jumpers</b> .....	<b>page 4</b>
<b>RSS Programming</b> .....	<b>page 5</b>
<b>Main/Standby Operation</b> .....	<b>page 6</b>
<b>Customizing Main/Standby Operation</b> .....	<b>page 8</b>



---

# FOREWORD

---

## Product Maintenance Philosophy

Due to the high percentage of surface-mount components and multi-layer circuit boards, the maintenance philosophy for this product is one of Field Replaceable Unit (FRU) substitution. The station is comprised of self-contained modules (FRUs) which, when determined to be faulty, may be quickly and easily replaced with a known good module to bring the equipment back to normal operation. The faulty module must then be shipped to the Motorola System Support Center for further troubleshooting and repair to the component level.

---

## Scope of Manual

This manual is intended for use by experienced technicians familiar with similar types of equipment. In keeping with the maintenance philosophy of Field Replaceable Units (FRU), this manual contains functional information sufficient to give service personnel an operational understanding of all FRU modules, allowing faulty FRU modules to be identified and replaced with known good FRU replacements.

The information in this manual is current as of the printing date. Changes which occur after the printing date are incorporated by Instruction Manual Revisions (SMR). These SMRs are added to the manuals as the engineering changes are incorporated into the equipment.

---

## Service and Replacement Modules

For complete information on ordering FRU replacement modules, or instructions on how to return faulty modules for repair, contact the System Support Center:

**Motorola System Support Center**  
2214 Galvin Drive  
Elgin, IL 60123  
1-800-221-7144  
Int'l 1-847-576-7300  
FAX 1-847-576-2172

The following FRU replacement modules are available:

Receiver Module (VHF Range 1)	TLN3250
Receiver Module (VHF Range 2)	TLN3251
Receiver Module (UHF Range 0)	DLN1215
Receiver Module (UHF Range 1)	TLN3313
Receiver Module (UHF Range 2)	TLN3314
Receiver Module (UHF Range 3)	TLN3373
Receiver Module (UHF Range 4)	TLN3374
Receiver Module (800 MHz)	TLN3315
Receiver Module (900 MHz)	TLN3316
Exciter Module (VHF Range 1)	TLN3252
Exciter Module (VHF Range 2)	TLN3253
Exciter Module (UHF Range 0)	DLN1214
Exciter Module (UHF Range 1)	TLN3305
Exciter Module (UHF Range 2)	TLN3306
Exciter Module (UHF Range 3)	TLN3375
Exciter Module (UHF Range 4)	TLN3376
Exciter Module (800 MHz)	TLN3307
Exciter Module (900 MHz)	TLN3308
Power Amplifier Module (VHF 25W, R1 & R2)	TLN3255
Power Amplifier Module (VHF 125W, R1)	TLN3379
Power Amplifier Module (VHF 125W, R2)	TLN3254
Power Amplifier Module (UHF Range 0; 110W)	DLN1216
Power Amplifier Module (UHF Range 1; 25W)	TLN3443
Power Amplifier Module (UHF Range 2; 110W)	TLN3446
Power Amplifier Module (UHF Range 4; 100W)	TLN3450
Power Amplifier Module (800 MHz 20W)	TLN3441
Power Amplifier Module (800 MHz 100W)	TLN3442
Power Amplifier Module (900 MHz 100W)	TLN3299
Station Control Module (Conventional/6809/EPIC V)	CLN8426
Station Control Module (EPIC IV)	CLN7692
Station Control Module ( <i>IntelliRepeater</i> EPIC V)	CLN8447
4-Wire Wireline Interface Module	CLN1295
8-Wire Wireline Interface Module	CLN1296
Power Supply Module (625W AC)	TLN3259
Power Supply Module (625W AC w/charger)	TLN3260
Power Supply Module (265W AC)	TLN3261
Power Supply Module (265W AC w/charger)	TLN3262
Power Supply Module (210W 12/24 V DC)	TLN3264
Power Supply Module (210W 48/60 V DC)	TLN3378
Power Supply Module (600W 24 V DC)	TLN3263
Power Supply Module (600W 48/60 V DC)	TLN3377
ASTRO Modem Card	TLN3265

---

## GENERAL SAFETY INFORMATION

The following general safety precautions must be observed during all phases of operation, service, and repair of the equipment described in this manual. The safety precautions listed below represent warnings of certain dangers of which we are aware. You should follow these warnings and all other safety precautions necessary for the safe operation of the equipment in your operating environment.

---

### General Safety Precautions

- Read and follow all warning notices and instructions marked on the product or included in this manual before installing, servicing or operating the equipment. Retain these safety instructions for future reference. Also, all applicable safety procedures, such as Occupational, Safety, and Health Administration (OSHA) requirements, National Electrical Code (NEC) requirements, local code requirements, safe working practices, and good judgement must be used by personnel.
- Refer to appropriate section of the product service manual for additional pertinent safety information.
- Because of danger of introducing additional hazards, do not install substitute parts or perform any unauthorized modifications of equipment.
- Identify maintenance actions that require two people to perform the repair. Two people are required when:
  - A repair has the risk of injury that would require one person to perform first aid or call for emergency support. An example would be work around high voltage sources. A second person may be required to remove power and call for emergency aid if an accident occurs to the first person. **Note** Use the *National Institute of Occupational Safety and Health (NIOSH) lifting equation to determine whether a one or two person lift is required when a system component must be removed and replaced in its rack.*
- If troubleshooting the equipment while power is applied, be aware of the live circuits.
- DO NOT operate the transmitter of any radio unless all RF connectors are secure and all connectors are properly terminated.
- All equipment must be properly grounded in accordance with *Motorola Standards and Guideline for Communications Sites 68P81089E50* (sometimes referred to as "R56 Manual") and specified installation instructions for safe operation.
- Slots and openings in the cabinet are provided for ventilation. To ensure reliable operation of the product and to protect it from overheating, these slots and openings must not be blocked or covered.
- Only a qualified technician familiar with similar electronic equipment should service equipment.
- Some equipment components can become extremely hot during operation. Turn off all power to the equipment and wait until sufficiently cool before touching.
- Never store combustible materials in or near equipment racks. The combination of combustible material, heat, and electrical energy increases the risk of a fire safety hazard.

---

## Human Exposure Compliance

This equipment is designed to generate and radiate radio frequency (RF) energy by means of an external antenna. When terminated into a non-radiating RF load, the base station equipment is certified to comply with Federal Communications Commission (FCC) regulations pertaining to human exposure to RF radiation. In accordance with the FCC Rules Part 1 section 1.1310 as published in title 47 code of federal regulations and procedures established in TIA/EIA TSB92, Report On EME Evaluation for RF Cabinet Emissions Under FCC MPE Guidelines. Compliance to FCC regulations of the final installation should be assessed and take into account site specific characteristics such as type and location of antennas, as well as site accessibility of occupational personnel (controlled environment) and the general public (uncontrolled environment). This equipment should only be installed and maintained by trained technicians. Licensees of the FCC using this equipment are responsible for insuring that its installation and operation comply with FCC regulations Part 1 section 1.1310 as published in title 47 code of federal regulations.

Whether a given installation meets FCC limits for human exposure to radio frequency radiation may depend not only on this equipment but also on whether the "environments" being assessed are being affected by radio frequency fields from other equipment, the effects of which may add to the level of exposure. Accordingly, the overall exposure may be affected by radio frequency generating facilities that exist at the time the licensee's equipment is being installed or even by equipment installed later. Therefore, the effects of any such facilities must be considered in site selection and in determining whether a particular installation meets the FCC requirements.

FCC OET Bulletin 65 provides materials to assist in making determinations if a given facility is compliant with the human exposure to RF radiation limits. Determining the compliance of transmitter sites of various complexities may be accomplished by means of computational methods. For more complex sites direct measurement of the power density may be more expedient. Additional information on the topic of electromagnetic exposure is contained in the *Motorola Standards and Guideline for Communications Sites* publication. Persons responsible for installation of this equipment are urged to consult the listed reference material to assist in determining whether a given installation complies with the applicable limits.

---

In general the following guidelines should be observed when working in or around radio transmitter sites: ~ All personnel should have electromagnetic energy awareness training

- All personnel entering the site must be authorized ~ Obey all posted signs
- Assume all antennas are active
- Before working on antennas, notify owners and disable appropriate transmitters
- Maintain minimum 3 feet clearance from all antennas ~ Do not stop in front of antennas
- Use personal RF monitors while working near antennas
- Never operate transmitters without shields during normal operation ~ Do not operate base station antennas in equipment rooms

For installations outside of the U.S., consult with the applicable governing body and standards for RF energy human exposure requirements and take the necessary steps for compliance with local regulations.

---

## References

- TIA/EIA TSB92 "Report On EME Evaluation for RF Cabinet Emissions Under FCC MPE Guidelines," Global Engineering Documents: <http://global.ihs.com/>
- FCC OET Bulletin 65 "Evaluating Compliance with FCC Guidelines for Human Exposure to Radio frequency Electromagnetic Fields": <http://www.fcc.gov/oet/rfsafety/>
- *Motorola Standards and Guideline for Communications Sites*, Motorola manual 68P81089E50
- IEEE Recommended Practice for the Measure of Potentially Hazardous Electromagnetic Fields – RF and Microwave, IEEE Std C95.3–1991, Publication Sales, 445 Hoes Lane, P.O. Box 1331, Piscataway, NJ 08855-1331
- IEEE Standard for Safety Levels with Respect to Human Exposure to Radio Frequency Electromagnetic Fields, 3 kHz to 300 GHz, IEEE C95.1–1991, Publication Sales, 445 Hoes Lane, P.O. Box 1331, Piscataway, NJ 08855-1331

---

## Receiver Circuitry Operation

### **Introduction**

The Receiver Circuitry accepts rf signals from the site receive antenna, performs filtering and dual conversion, and outputs a digitized receive signal to the Station Control Module.

### **Receiver Module Operation**

The receive signal is input from the site receive antenna to a multi-pole preselector filter which provides highly selective bandpass filtering. The filtered signal is then amplified and fed to the rf input of the 1st mixer, which mixes the signal with an injection signal generated by the synthesizer/VCO, resulting in a 21.45 MHz (VHF) or a 73.35 MHz (UHF, 800, 900) 1st i-f (intermediate frequency) signal. (The injection signal frequency is determined by frequency programming data from the Station Control Module via the SPI bus.)

The 21.45 MHz or 73.35 MHz 1st i-f signal is filtered and input to a custom receiver IC. This component contains circuitry for 2nd injection and mixing, amplification, and A/D (analog to digital) conversion, resulting in a digitized receive signal. This signal is fed as differential data to the Station Control Module.

---

## Station Control Module Operation

### **Introduction**

The Station Control Module (SCM) is the microprocessor – based controller for the station. Major components include an MC68360 microprocessor, a 56311 Digital Signal Processor (DSP), and two programmable devices, a CPLD for the host and a FPGA for the DSP. The SCM operates as follows:

### **Station Control Module Operation**

The Host Microprocessor ( $\mu$ P) serves as the controller for the SCM, operating from the station software stored in FLASH memory. This software determines the system capabilities of the station (analog, ASTRO, etc.) The Host  $\mu$ P communicates with the station modules and the SCM circuitry via address and data buses, an HDLC bus, and a SPI bus. External communications ports include a serial port SCM (front panel and backplane) and an Ethernet port (backplane).

The DSP and DSP FPGA perform the necessary digital processing for the station audio and data signals. The DSP circuitry interfaces with the Receiver Module (receive audio), the Exciter Module (modulation signals), the Wireline Interface Board (wireline audio), and external audio devices (microphone, handset, external speaker, and station local speaker).

The 2.1 MHz Reference Oscillator generates the reference signal used by the Receiver and Exciter Modules.



---

## Wireline Interface Board Operation

**Note:** The WIB is offered in 4-wire and 8-wire models. The WIB shown in the block diagram is a simplified 4-wire model. Refer to the functional sections located behind tab WIRELINE CIRCUITRY for details on both models.

### Introduction

The Wireline Interface Board (WIB) serves as the interface between the customer telephone lines and the station. In general, the WIB processes and routes all wireline audio signals between the station and the landline equipment (such as consoles, modems, etc.). Landline-to-station and station-to-landline audio signals are connected to the WIB via copper pairs at the rear of the station.

### Wireline Interface Board Operation

The WIB contains a microprocessor, two FLASH memory ICs (which contain the WIB operating software downloaded by the SCM), and an ASIC device to process and route the various audio signals. Analog and ASTRO signals are processed as follows.

- Analog signals are converted to digital signals and routed to the SCM via the TDM (time division multiplex) bus.
- ASTRO and ASTRO CAI data signals are processed by an ASTRO modem card (daughter board plugged into the WIB) and sent to/from the SCM via the HDLC bus. (The station operates in *transparent* mode only, and **does not** perform encryption or decryption of the ASTRO or ASTRO CAI signal.)

The WIB also contains the I/O circuitry used with the WildCard Option. Refer to the *Quantar/Quantro* RSS User's Guide (68P81085E35) for more information on the WildCard Option.

---

## Power Supply Module Operation

The Power Supply Module is a switching-type power supply which accepts an ac input (90–280 V ac, 47–63 Hz) and generates the necessary dc operating voltages for the station modules. Stations rated at 20/25 W output power are equipped with Power Supply Modules which generate +5 and +14.2 V dc. Stations rated at 100/110/125 W output power are equipped with Power Supply Modules which generate +5, +14.2 V, and +28 V dc.

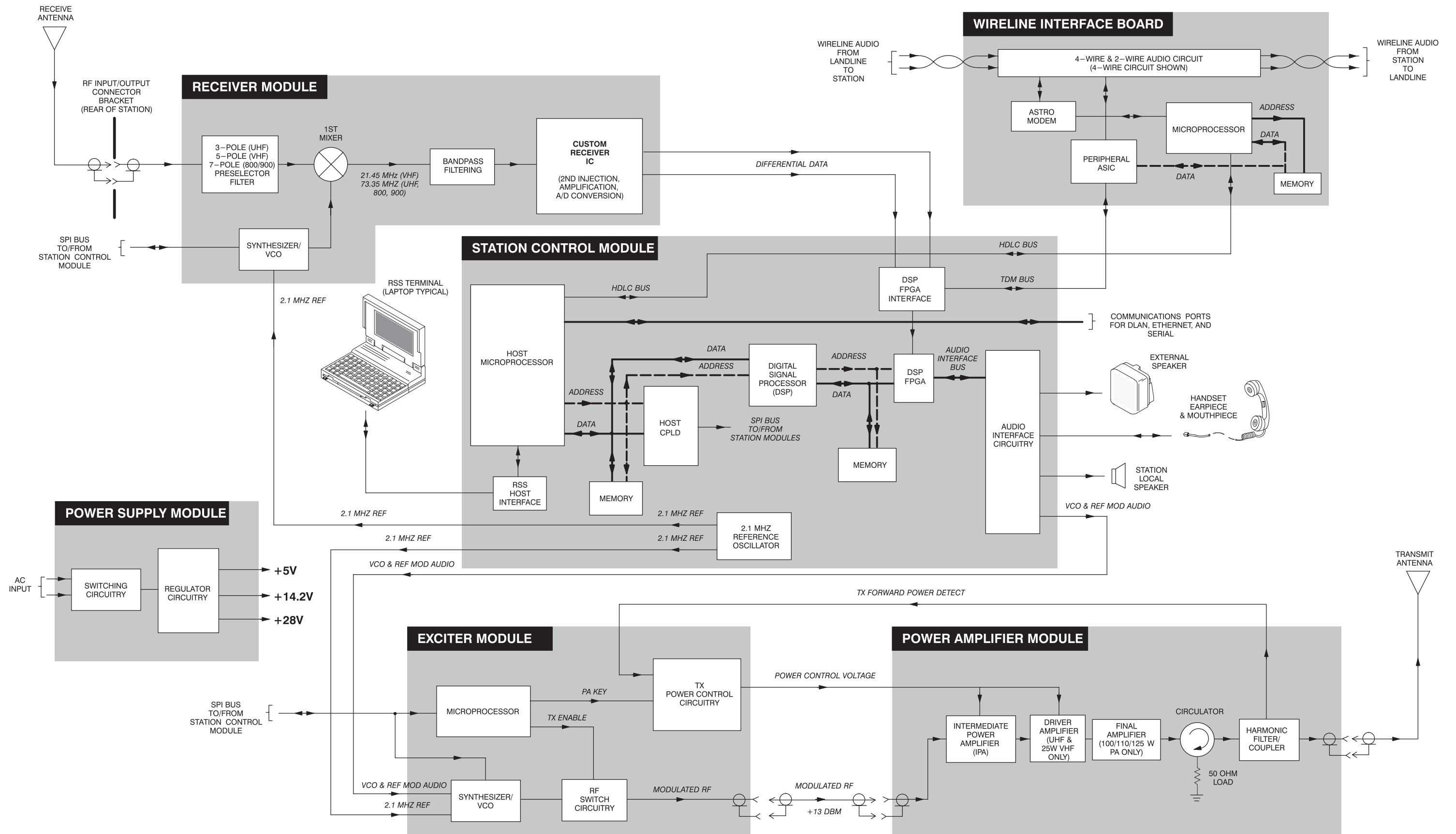
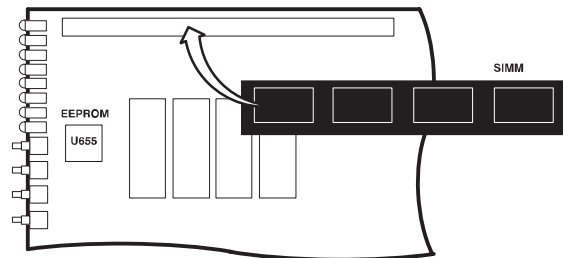

Figure 3. Quantar Station Functional Block Diagram

## Replacing Station Control Module (Conventional/6809) (Continued)

### Replacement Procedure (continued)



**Note:** When inserting Station Control Board into cage, place your thumbs on the BNC and D-type connectors and firmly push the board into the backplane connector.

- Step 5.** Install replacement Station Control Board by sliding board into cage and firmly seating the board card-edge connectors into the backplane. (**Do not** slam the board against the backplane or push any harder than necessary to seat the connectors.)
- Step 6.** Replace the front panel by pressing it into place and replacing the two screws. Be sure the 2-wire cable from the local speaker is connected to the 3-pin connector at the bottom front of the Station Control Board. If the connector is not keyed (earlier models), you may connect the 3-pin connector in either polarity.
- Step 7.** Restore power to the station.

### Post-Replacement Optimization Procedure

- Step 1.** Replacement Station Control Modules are shipped with default data programmed into the codeplug (EEPROM located on board). After replacing a Station Control Board, you must download codeplug data (unique to the particular station) to the replacement board codeplug. Simply retrieve the file from your archive and follow the instructions in the RSS User's Guide (68P81085E35) for saving data to the codeplug. Note that if no archive codeplug file exists, you may create a new codeplug by copying the *training.cp* codeplug file (supplied with the RSS) and then program it as necessary to meet the particular station's requirements.
- Step 2.** Calibrate the reference oscillator (station reference) by performing the procedure in the Routine Maintenance section of this manual.
- Step 3.** Perform the alignment procedures listed in the sidebar as described in the RSS User's Guide (68P81085E35).

#### Alignment Procedures

- RX Wireline
- TX Wireline
- Squelch Adjust
- Battery Equalization (if required)
- Power Output
- Tx Deviation Gain Adjust
- Reference Modulation

For *ASTRO* stations, also perform RSSI and Simulcast/*ASTRO* Launch Time Offset alignment.

For 6809 Trunking stations, also perform TDATA alignment.

## Replacing Station Control Module (for modules in IntelliRepeater Ethernet Networks)

**Note** If the Physical Address and/or the IP Address cannot be read, contact the System Support Center at 1-800-221-7144.

**Note** Use an IC Extraction Tool (Motorola Part No. 01-80386A04) to remove the firmware devices.

### Replacement Procedure

- Step 1.** If the module is capable of communicating with the RSS, connect the PC to the RSS port, start the RSS program, and save the codeplug from the station to a file on the PC hard disk. This will allow the codeplug information to be downloaded to the codeplug located on the replacement Station Control Board. If the module cannot communicate with the RSS, an archive file (if available) of the particular station codeplug may be downloaded. If no archive codeplug file exists, you must program the codeplug as described in the RSS User's Guide (68P81085E35).
- Step 2.** Using the RSS, read the *IP Address* and *Physical Address* assigned to the station and jot them down. (From the RSS **Main Menu**, go to **Service:Ethernet Parameters** to read the *IP Address* and the *Physical Address*.)
- Step 3.** Turn off station power (refer to page 22).
- Step 4.** Disconnect the station from the Ethernet LAN as described below.

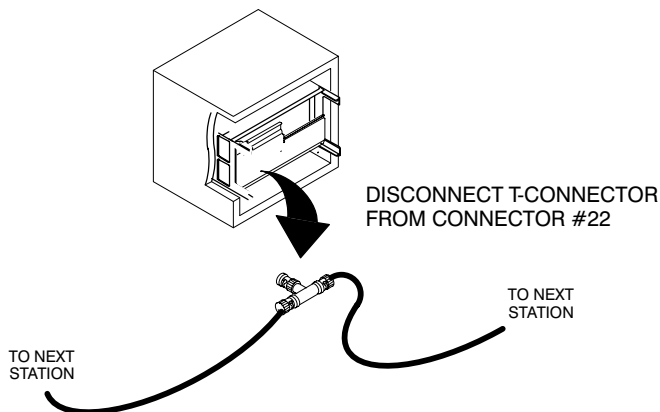

- Step 5.** Using a Torx #15 driver, remove front panel and Station Control Board as described in Figure 6.
- Step 6.** The Station Control Board software must now be removed from the old board and installed onto the replacement board. The software is contained on a single FLASH SIMM. You must remove the FLASH SIMM from the replacement board and install the FLASH SIMM from the old board. The following illustration shows the location of the FLASH SIMM.

## Replacing Station Control Module (for modules in *IntelliRepeater* Ethernet Networks) (Continued)

**Note** If the existing FLASH SIMM is faulty, contact the System Support Center at 1-800-221-7144 to obtain a replacement part.

**Note** The replacement board must have the same model number as the faulty board (e.g., CLN6960). If it does not, contact the System Support Center at 1-800-221-7144 for instructions on how to proceed.

**Note:** When inserting Station Control Board into cage, place your thumbs on the BNC and D-type connectors and firmly push the board into the backplane connector.

### Alignment Procedures

- RX Wireline
- TX Wireline
- Squelch Adjust
- Battery Equalization (if required)
- Power Output
- Tx Deviation Gain Adjust
- Reference Modulation

For *ASTRO* stations, also perform RSSI and Simulcast/*ASTRO* Launch Time Offset alignment.

### Replacement Procedure (continued)

**Software on Single FLASH SIMM**

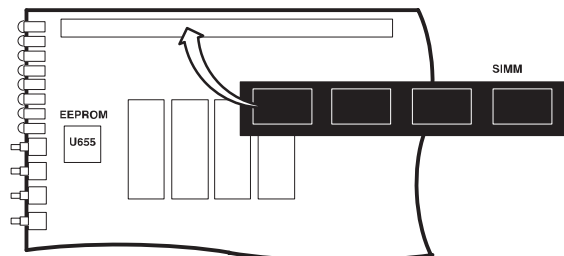

- Step 7.** Install replacement Station Control Board by sliding board into cage and firmly seating the board card-edge connectors into the backplane. (**Do not** slam the board against the backplane or push any harder than necessary to seat the connectors.)
- Step 8.** Replace the front panel by pressing it into place and replacing the two screws. Be sure the 2-wire cable from the local speaker is connected to the 3-pin connector at the bottom front of the Station Control Board. If the connector is not keyed (earlier models), you may connect the 3-pin connector in either polarity.
- Step 9.** Restore power to the station.

### Post-Replacement Optimization Procedure

- Step 1.** Replacement Station Control Modules are shipped with default data programmed into the codeplug (EEPROM located on board). After replacing a Station Control Board, you must download codeplug data (unique to the particular station) to the replacement board codeplug. Simply retrieve the file from your archive and follow the instructions in the RSS User's Guide (68P81085E35) for saving data to the codeplug. Note that if no archive codeplug file exists, you may copy a codeplug from another station at the site and save it to this station.  
**Important!** When the RSS prompts you to "Crossload" the other stations at the site, answer **NO**.
- Step 2.** Using the RSS, navigate to **Service:Ethernet Parameters** and change the *IP Address* and *Physical Address* to the addresses you read in Step 2 on page 28.
- Step 3.** Calibrate the reference oscillator (station reference) by performing the procedure in the Routine Maintenance section of this manual.
- Step 4.** Perform the alignment procedures listed in the sidebar as described in the RSS User's Guide (68P81085E35).
- Step 5.** Turn off station power (refer to page 22).
- Step 6.** Reconnect the T-connector from the Ethernet LAN.
- Step 7.** Restore power to the station.

1

Remove the two screws from top and bottom of Station Control Module front panel.

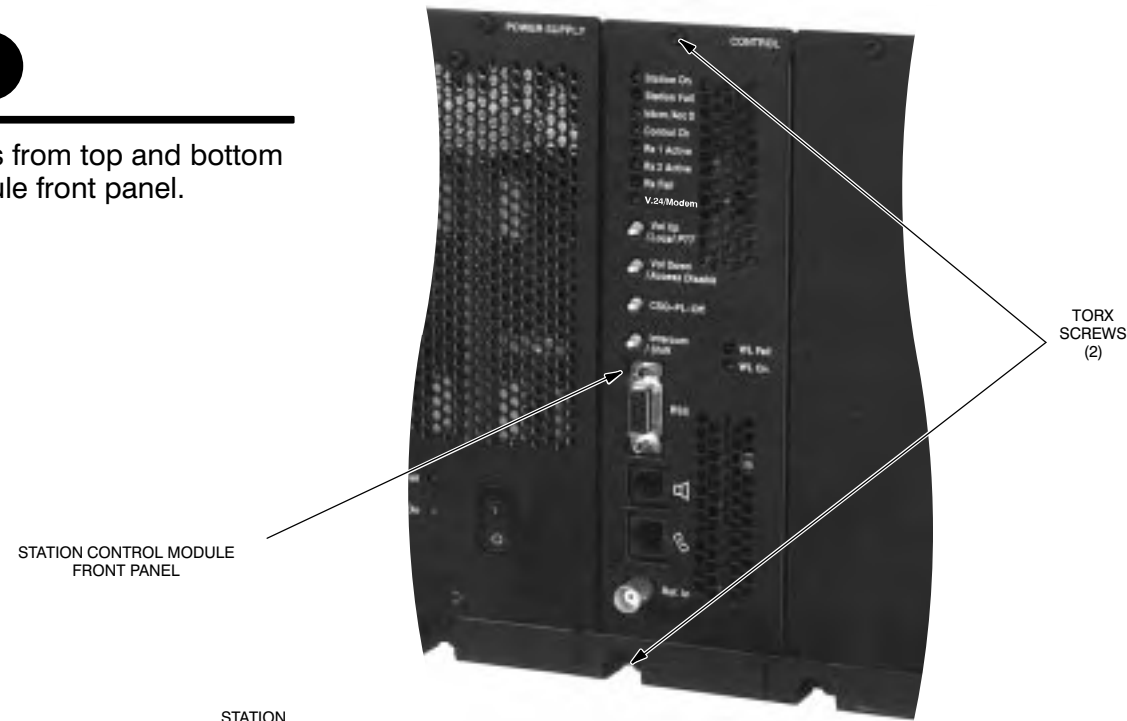

2

Partially remove front panel and position the board extraction tab on the bottom rail of the cage and slide the panel to the left until the lip of the tab is positioned behind the cutout in the Station Control Board.

EXTRACTOR TAB BEHIND BOARD CUTOUT

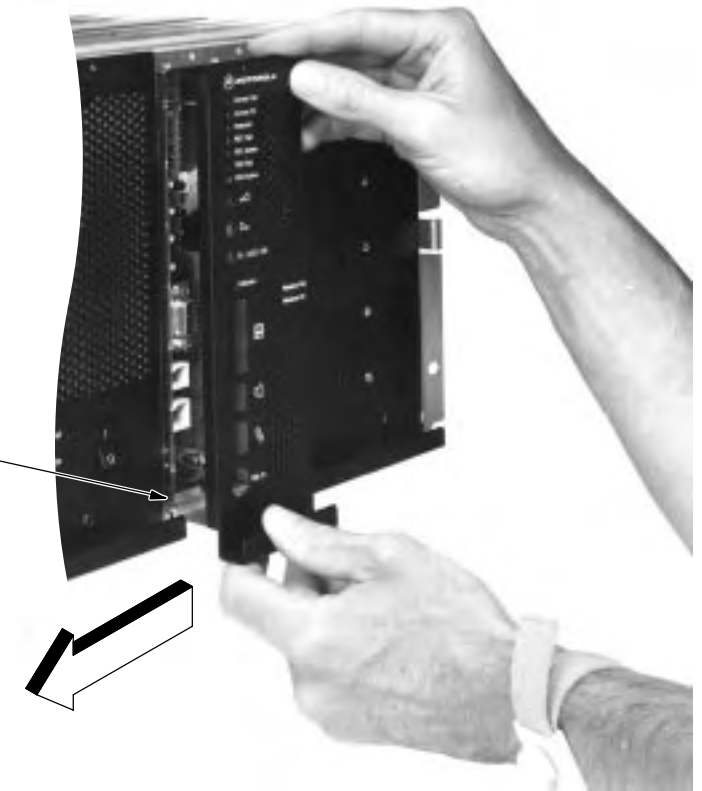

STATION CONTROL BOARD



3

Tip back on the panel to pry the Station Control Board out of the backplane connectors.

4

Remove Station Control Board from cage.



Figure 6. Removal Procedure for Station Control Board (Quantar VHF Station Shown)

## Replacing Wireline Interface Board

**Note** A later model board (CLNxxxx) can be used to replace both later model boards and earlier model boards (TRNxxxx). However, earlier model boards cannot be used to replace later model boards. (Later model boards support either EPROMs or FLASH; earlier model boards support only EPROMs.)

### Replacement Procedure

- Step 1.** Turn off station power (refer to page 22).
- Step 2.** Using a Torx #15 driver, remove anti-vibration screw(s) (if installed) from top and/or bottom of module front panel.
- Step 3.** Remove Station Control Module front panel and Wireline Interface Board as described in Figure 6.
- Step 4.** Set all jumpers on replacement board to match those on the faulty board. These include input/output impedance matching jumpers, 2-wire/4-wire select jumper, and dc remote control selection jumpers.
- Step 6.** Install replacement Wireline Interface Board by sliding board into cage and firmly seating the board card-edge connectors into the backplane. (**Do not** slam the board against the backplane or push any harder than necessary to seat the connectors.)
- Step 7.** Replace the front panel by pressing it into place and replacing the two screws. Be sure the 2-wire cable from the local speaker is connected to the 3-pin connector at the bottom front of the Station Control Board. If the connector is not keyed (earlier models), you may connect the 3-pin connector in either polarity.
- Step 8.** Restore power to the station.

### Post-Replacement Optimization Procedure

Perform the *Rx Wireline* and *Tx Wireline* adjustment procedures located in the RSS User's Guide (68P81085E35).

---

---

## 1 DESCRIPTION

The Models CLN8426A and CLN8447A station control modules (SCM) are described in this section. A general description, identification of controls, indicators, and inputs/outputs, a functional block diagram, and functional theory of operation are provided. The information provided is sufficient to give service personnel a functional understanding of the module, allowing maintenance and troubleshooting to the module level. (Refer also to the *Maintenance and Troubleshooting* section of this manual for detailed troubleshooting procedures for all modules in the station.)

---

### General Description

The SCM serves as the main controller for the station. The SCM board contains a 68EN360 microprocessor, a 56311 digital signal processor (DSP), and support circuitry that combine to provide signal processing and operational control over the other station modules. The SCM also contains the station operating software (stored in FLASH memory) and codeplug which define the personality of the station, including system capabilities (ASTRO, IntelliRepeater, etc.) and operating parameters such as output power and operating frequency.

The CLN8426A provides conventional operation along with MRTI and 6809 trunking capabilities. The CLN8447A is a full-featured model required for use in IntelliRepeater applications. Specific differences between the models are shown throughout the functional block diagram (Figure 2).

---

### Overview of Circuitry

The SCM contains the following circuitry:

- **Host Microprocessor** ( $\mu\text{P}$ )— The 68EN360  $\mu\text{P}$  is the central controller of the SCM and station
- **Non-Volatile Memory** — consists of a FLASH SIMM module that contains the station operating software and data, and an EEPROM that contains the station codeplug data
- **SDRAM Memory** — Synchronous RAM into which station software is downloaded and executed



- **External Line Interface Circuitry** — provides interface between the SCM and external devices such as IntelliRepeater DLAN ports, RSS port, an Ethernet port, and miscellaneous backplane connectors
- **Digital Signal Processor (DSP) and DSP FPGA Circuitry** — performs high-speed processing of audio and signaling data signals
- **Station Reference Circuitry** — generates the 2.1 MHz reference signal used throughout the station
- **HDLC Bus Control Circuitry** — provides bus control to allow host communications port SCC3 to communicate with the wireline interface board (WIB) and other optional modules via the HDLC interprocessor communications bus
- **Audio Interface Circuitry** — routes the various audio input signals (such as microphone, wireline, and receiver audio) to output devices (such as external speaker, built-in local speaker, and exciter modulation inputs)
- **Input/Output Ports Circuitry** — two 32-line output buses allow miscellaneous control signals to be sent to various circuits throughout the station; two 32-line input buses allow miscellaneous inputs to be received from throughout the station
- **Front Panel LEDs and Switches** — general purpose input/output ports control eight status LEDs and accept inputs from four momentary switches, all located on the SCM front panel
- **Supply Voltage Circuitry** — contains filtering and regulator circuitry which accepts +14.2 V and +5 V from backplane and generates the operating voltages required by the SCM circuitry

## 2 CONTROLS, INDICATORS, AND INPUTS/OUTPUTS

Figure 1 shows the SCM controls, indicators, and all input and output external connections.

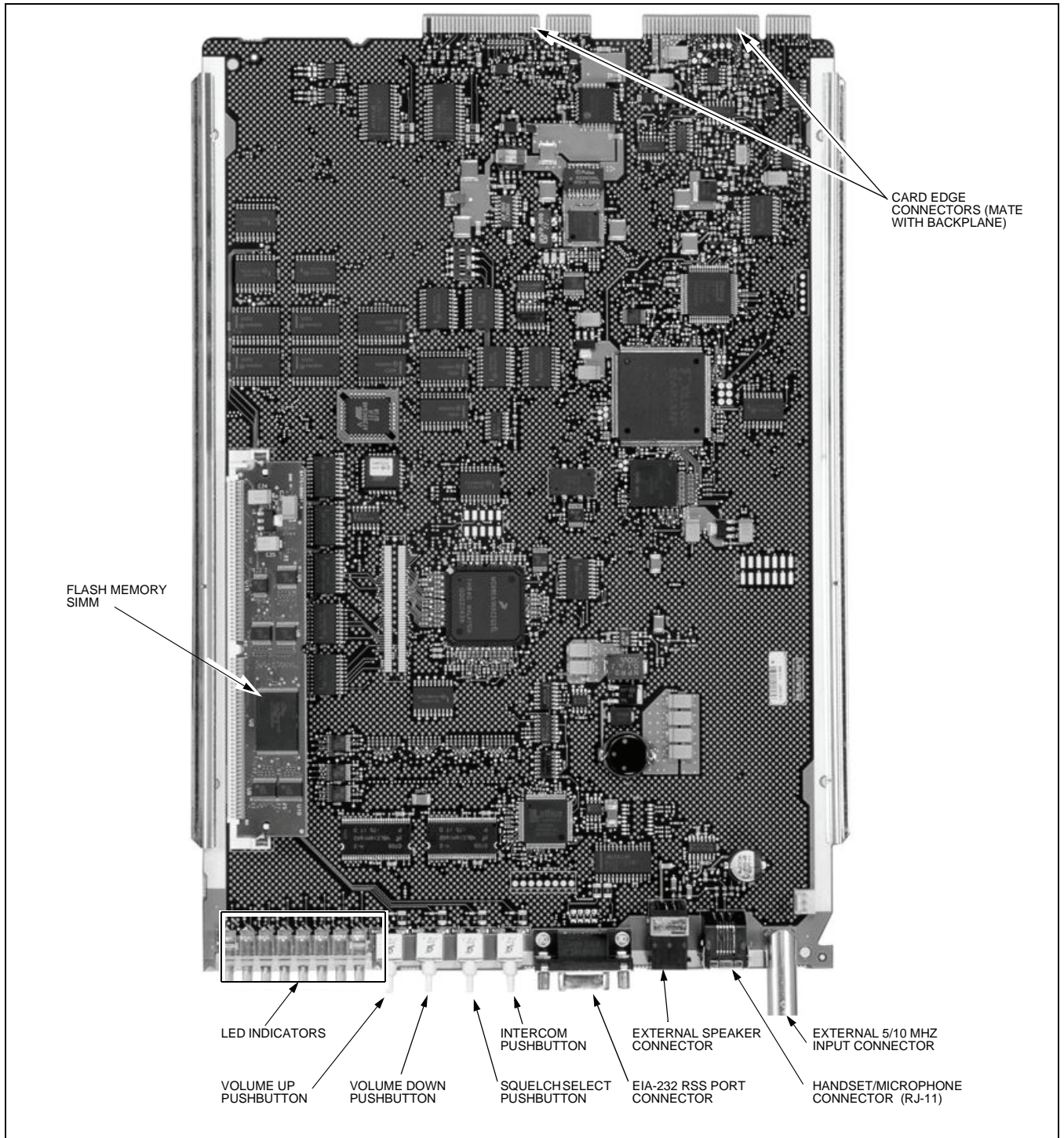

**Figure 1** Station Control Module Controls, Indicators, and Inputs/Outputs

## 3 FUNCTIONAL THEORY OF OPERATION

The following theory of operation describes the operation of the SCM circuitry at a functional level. The information is presented to give the service technician a basic understanding of the functions performed by the module in order to facilitate maintenance and troubleshooting to the module level. Refer to Figure 2 for a block diagram of the SCM.

---

### Host Microprocessor

#### *Overview*

The host  $\mu$ P serves as the main controller for the SCM (and station). The host  $\mu$ P, an MC68EN360 running at a clock speed of 25 MHz, controls the operation of the station as determined by the station software (contained in a FLASH SIMM module) and the station codeplug (EEPROM).

#### *Communications Buses*

The host  $\mu$ P provides six general-purpose serial communications buses, as follows:

- **SCC1** — Used as Ethernet port for high-speed communications, either to connect to the Ethernet local network of an IntelliRepeater trunking site or to allow station software to be downloaded from a local PC into the FLASH memory
- **SCC2** — Used as communications port to allow the station to connect into the local network of an IntelliRepeater trunking site; external connections are provided by a 9-pin D-type connector (#19) located on backplane
- **SCC3** — Used as the interprocessor communications bus (HDLC protocol) to allow the host  $\mu$ P to communicate with the WIB and other optional modules
- **SCC4** — Used as RS-232 port for connections to external equipment, such as a modem
- **SMC1** — Used as RS-232 port for RSS communications (9-pin D-type connector #20 on backplane)
- **SMC2** — Used as RS-232 port for RSS communications (9-pin D-type connector located on SCM front panel)

#### *Address and Data Buses*

The  $\mu$ P is equipped with a 28-line address bus used to access the non-volatile memory, SDRAM memory, and provide control (via memory mapping) for other circuitry in the SCM. A 32-line data bus (buffered for the non-volatile memory) is used to transfer data to/from the SCM memory, as well as other SCM circuitry.

#### *SPI Bus*

The host  $\mu$ P also controls the SPI bus, a general-purpose communications bus that allows the host  $\mu$ P to communicate with other modules in the station.

***SDRAM Controller***

The host  $\mu$ P and CPLD provides signals necessary to access and refresh the SDRAM memory.

***25 MHz Clock Circuitry***

A crystal-controlled 25 MHz clock circuit and buffer provide the 25 MHz clock signal to the host  $\mu$ P.

---

**Non-Volatile Memory*****Station Software FLASH Memory***

The station software resides in a FLASH SIMM module. The FLASH SIMM is accessed by the host  $\mu$ P via the 28-line host buffered address bus and the 32-line host buffered data bus.

***Codeplug EEPROM***

The data which determines the station personality resides in an 8K x 8 codeplug EEPROM (U1700). Stations are shipped from the factory with generic default data programmed into the codeplug EEPROM. Field programming is performed during installation using the Radio Service Software (RSS) program to enter additional customer-specific data, such as site output power, time-out timer settings, etc.

---

**SDRAM Memory**

Each SCM contains 2Mx32 of SDRAM into which the station software is downloaded and run. The SDRAM also provides short-term storage for data generated/required during normal operation. Read and write operations are performed using the host buffered address and host buffered data buses.

The SDRAM memory locations are sequentially refreshed by the column and row signals from the host  $\mu$ P and auxiliary CPLD.

---

## External Line Interface Circuitry

### ***IntelliRepeater DLAN Network Port***

A DLAN port is provided on the station backplane to allow the station to connect into the local network of an IntelliRepeater trunking site. This DLAN port is provided by host  $\mu$ P serial communication bus SCC2.

SCC2 communicates with an RS-485 bus transceiver, which provides DLAN+ and DLAN- signals. These signals are connected to a 9-pin D-type connector (#19) located on the station backplane, which typically mates with a PhoneNET adapter module connected into the IntelliRepeater local network.

### ***Ethernet Port***

An Ethernet port is provided via a BNC connector on the station backplane which allows the station to connect into the Ethernet local network of an IntelliRepeater trunking site. The Ethernet port may also be used to allow station software to be downloaded from a local PC into the FLASH SIMM module. This Ethernet port is provided by host  $\mu$ P serial communication bus SCC1.

### ***General Purpose RS232 Serial Port***

A general purpose RS-232 communications port is provided by host  $\mu$ P serial communication bus SCC4. This port is available at a DB-25 connector (#15) located on the station backplane, and may be used to connect external equipment such as an external modem.

### ***RSS Port (Backplane)***

A 9-pin D-type connector (#20) is provided on the station backplane to allow service personnel to connect a PC loaded with the Radio Service Software (RSS) and perform programming and maintenance tasks. The RSS port may also be used to allow station software to be downloaded from a local PC into the FLASH SIMM module. This RSS port is provided by host  $\mu$ P serial communication bus SMC1 which communicates with the RSS terminal via EIA-232 Bus Receivers/Drivers.

### ***RSS Port (Front Panel)***

A 9-pin D-type connector is provided on the SCM front panel to allow service personnel to connect a PC loaded with the Radio Service Software (RSS) and perform programming and maintenance tasks. The RSS port may also be used to allow station software to be downloaded from a local PC into the FLASH SIMM module. This RSS port is provided by host  $\mu$ P serial communication bus SMC2 which communicates with the RSS terminal via EIA-232 Bus Receivers/Drivers.

---

## Digital Signal Processor (DSP) and DSP FPGA Circuitry

### **General**

All station transmit and receive audio/data is processed by the DSP and related circuitry. This circuitry includes the DSP IC, the DSP FPGA, and the DSP FPGA interface circuitry. All audio signals in and out of the DSP are in digitized format.

**Inputs** to the DSP circuitry are:

- Digitized receive signals from the receiver module
- Audio from handset or microphone connected to appropriate SCM front panel connector; signal is digitized by the CODEC IC (audio interface circuitry) before being sent to the DSP via the audio interface bus
- Digitized voice audio/data from WIB and other optional modules via TDM bus
- ASTRO modem data from WIB via HDLC bus
- 6809/MRTI transmit audio

**Outputs** from the DSP circuitry are:

- Digitized voice audio/data from DSP to WIB and other optional modules via TDM bus
- Digitized voice audio from DSP to external speaker, built-in speaker, or handset earpiece via audio interface bus and audio interface circuitry
- Digitized voice audio/data from DSP to exciter module (modulation signals) via audio interface bus and audio interface circuitry
- 6809/MRTI transmit audio

### **Digital Signal Processor (DSP)**

The DSP, a 56311 operating at an internal clock speed of 100 MHz, accepts and transmits digitized audio to/from the various modules in the station. The DSP provides address and data buses to receive/transmit digitized audio (via the DSP FPGA) and to access the DSP program and signal processing algorithms contained in DSP memory.

### **DSP FPGA**

The DSP FPGA operates under control of the DSP to provide a number of functions, as follows:

- Interfaces with the DSP via the DSP address and data buses
- Accepts 16.8 MHz signal from Station Reference Circuitry and outputs a 2.1 MHz reference signal used throughout the station
- Provides interfaces for the HDLC bus, TDM bus, and serial bus used to communicate with the Receiver Module
- Accepts digitized data from Receiver Module via DSP FPGA Interface Circuitry
- Provides interfaces for several A/D and D/A converters

---

## Station Reference Circuitry

**Note:** Two BNC connectors (one 50  $\Omega$  input located on SCM front panel, one high impedance input located on the station backplane) are provided to allow an external 5/10 MHz source to be connected to the  $OSC_{in}$  input to the PLL to perform frequency netting. Refer to the Maintenance section in this manual for recommended intervals and procedures for netting the station reference.

The station reference circuitry consists of a phase-locked loop (PLL) comprised of a high-stability VCO and a PLL IC. The output of the VCO is a 16.8 MHz signal which is fed to the DSP FPGA. The FPGA divides the signal by 8 and outputs a 2.1 MHz signal which is separated and buffered by a splitter and output to the Exciter Module and Receiver Module as 2.1 MHz REF.

The Station Reference Circuitry may operate in one of three modes:

- **Normal Mode** — In this mode, the control voltage is turned off (via control voltage enable switch) and the high-stability VCO operates in an open loop mode; stability of the VCO in this mode is 1 PPM per year after the first 6 months.
- **Manual Netting Mode** — Periodically, an external 5/10 MHz source is required to fine tune, or “net”, the 16.8 MHz reference signal. In this mode, the PLL compares the 5/10 MHz reference and a sample of the 16.8 MHz VCO output and generates up/down pulses. The host  $\mu P$  reads the pulses (via SPI bus) and sends correction signals (via SPI bus) to the VCO to adjust the output frequency to 16.8 Mhz  $\pm 0.3$  ppm.
- **High-Stability Mode** — For some systems, such as simulcast systems, the free-running stability of the VCO is unacceptable for optimum system performance. Therefore, an external 5/10 MHz source is connected permanently to one of the BNC connectors. In this mode, the PLL compares the 5/10 MHz reference and a sample of the 16.8 MHz VCO output and generates a dc correction voltage. The control voltage enable switch is closed, allowing the control voltage from the PLL to adjust the high-stability VCO frequency to 16.8 MHz  $\pm$  the stability of the external 5/10 MHz source. The VCO operates in this closed loop mode and is continually being frequency controlled by the control voltage from the PLL.

---

## HDLC Bus Control Circuitry

The HDLC bus control circuitry provides three-state buffering and data routing for the interprocessor communications bus (a serial data bus implementing HDLC protocol). This bus allows the host  $\mu P$  to communicate with the host  $\mu P$  located on the WIB and other optional modules via an interprocessor communications bus.

---

## Audio Interface Circuitry

### **General**





The audio interface circuitry interfaces external analog audio inputs and outputs with the DSP circuitry. This includes the analog, integrated circuit EPSILON, and discrete amplifier and switch circuitry.

### **External Audio Sources**

A multiplexer, under control of the host  $\mu$ P, is used to select one of eight possible external audio input sources (four for diagnostic loopback signals, two for future use, one for 6809/MRTI transmit audio, and one for handset or microphone audio). The selected audio source signal is converted to a digital signal by the A/D portion of the CODEC IC and sent to the DSP FPGA via the audio interface bus. The DSP circuitry processes the signal and routes it to the desired destination.

### **External Audio Destinations**

Digitized audio from the DSP circuitry is applied to the D/A portion of the CODEC EPSILON and is then sent to one of four external devices:

- External Speaker — connects to  jack located on SCM front panel
- Handset Earpiece/Microphone — connects to RJ-11 jack (  ) located on SCM front panel
- Local Built-In Speaker — internal speaker and  $\frac{1}{2}$  W audio amplifier; may be switched on/off and volume controlled by using volume up (  ) and down (  ) buttons on SCM front panel
- J14 on Station Backplane — 6809/MRTI receive audio output to external MRTI Module

### **Exciter Modulation Signals**

Digitized audio/data intended to be transmitted from the station is sent from the DSP circuitry to a D/A converter via the TX/Voice Audio signal (part of the serial synchronous interface bus, connected between the DSP and the DSP FPGA). The digitized signal is converted to analog, level shifted and amplified, and fed to a 0-6 kHz filter. The output of the filter is then fed to one of the inputs of a multiplexer. The output of the multiplexer is fed to two individual digitally controlled potentiometers (each of which is adjusted by the host  $\mu$ P via the SPI Bus) and applied to the exciter module as modulation signals VCO MOD AUDIO and REF MOD AUDIO.



---

## Input/Output Ports

### ***Input Ports***

Two general-purpose 32-line input ports are provided to allow various input signals from the SCM and station circuitry to be accepted and sent to the host  $\mu$ P. The two ports (I/O Port P0 In and I/O Port P1 In) are each comprised of 32 lines which come from circuitry in the SCM as well as other modules in the station via the backplane. The buses are received by buffers which make the data available to the host  $\mu$ P via the host buffered data bus. Typical inputs include the pushbutton switches located on the SCM front panel and the MIC PTT signal from the handset/microphone.

### ***Output Ports***

Two general-purpose 32-line output ports are provided to allow various control signals from the host  $\mu$ P to be output to the SCM and station circuitry via the backplane. The two ports (I/O Port P0 Out and I/O Port P1 Out) are each comprised of 32 lines which come from the host buffered data bus via latches. Typical output control signals include the control lines for the eight LEDs located on the SCM front panel and the local speaker enable signal.

---

## 6809/MRTI Interface Circuitry

### ***6809 Trunking Interface***

TX DATA from the 6809 trunking controller is received by the station via J14 on the station backplane. The signal is routed through nominal filtering on the 6809/MRTI interface circuitry and fed to the audio interface circuitry. The T DATA signal is then waveshaped/filtered and fed to an A/D converter in the EPSILON IC, which outputs a digital signal to the DSP via the audio interface bus.

6809 RX AUDIO is output from the DSP to the local audio circuitry via the audio interface bus. The signal is amplified, filtered, buffered in the EPSILON IC, and output through nominal filtering on the 6809/MRTI interface circuitry to the 6809 trunking controller via J14 on the station backplane.

### ***MRTI Interface***

MRTI AUDIO from an external MRTI module is received by the station via J14 on the station backplane. The signal is routed through the 6809/MRTI interface circuitry and fed to one input of an 8-to-1 multiplexer. If selected, the MRTI TX AUDIO signal is converted to a digital signal by the A/D portion of the EPSILON IC CODEC and sent to the DSP FPGA via the audio interface bus.

MRTI RX AUDIO is output from the DSP to the local audio circuitry via the audio interface bus. The signal is amplified, filtered, buffered in the EPSILON IC, and output through the 6809/MRTI interface circuitry to the external MRTI module via J14 on the station backplane.

---

## Front Panel LEDs and Switches

**Note:** Refer to the Troubleshooting section of this manual for complete details on the interpretation of the LEDs.

**Note:** Refer to the Operation section of this manual for complete details on the use of the pushbutton switches.

### LEDs

Eight status LEDs on the SCM front panel provide visual indications of various station operating conditions. The LEDs are controlled by eight lines from I/O Port P0 Out.

### Switches

Four momentary contact pushbutton switches are provided on the SCM front panel to allow various station functions to be selected. Pressing a pushbutton causes a high to be sent to the host  $\mu$ P via I/O Port P0 In.

---

## Supply Voltages Circuitry

The SCM contains on-board regulator and filtering circuitry to generate the various operating voltages required by the SCM circuitry. +14.2 V (A+) and +5V Vcc from the backplane are used as sources for the following supply voltage circuits:

- **VCCA Supply Circuitry** — is a +5V regulated supply derived from +14.2 V. It supplies the station reference, EPSILON, 5V-3V translators circuitry.
- **Filtering Circuitry** — filters the +14.2 V and +5V from the backplane to provide A+ and VCC, respectively, for the SCM digital circuitry.
- **3.3 V Converter Circuitry** — Derived from Vcc to supply power to the DSP, FPGA, SDRAM and aux CPLD.
- **Vcc Circuitry** — 5 V from the backplane supplies power to the 68360 host processor, flash SIMM and interface circuitry, and digital portions of the EPSILON IC.
- **2.5V regulator circuit** — derived from Vcc and supplies the core voltage of the DSP-FPGA
- **1.8V regulator circuit** — derived from Vcc and supplies the core voltage of the DSP.

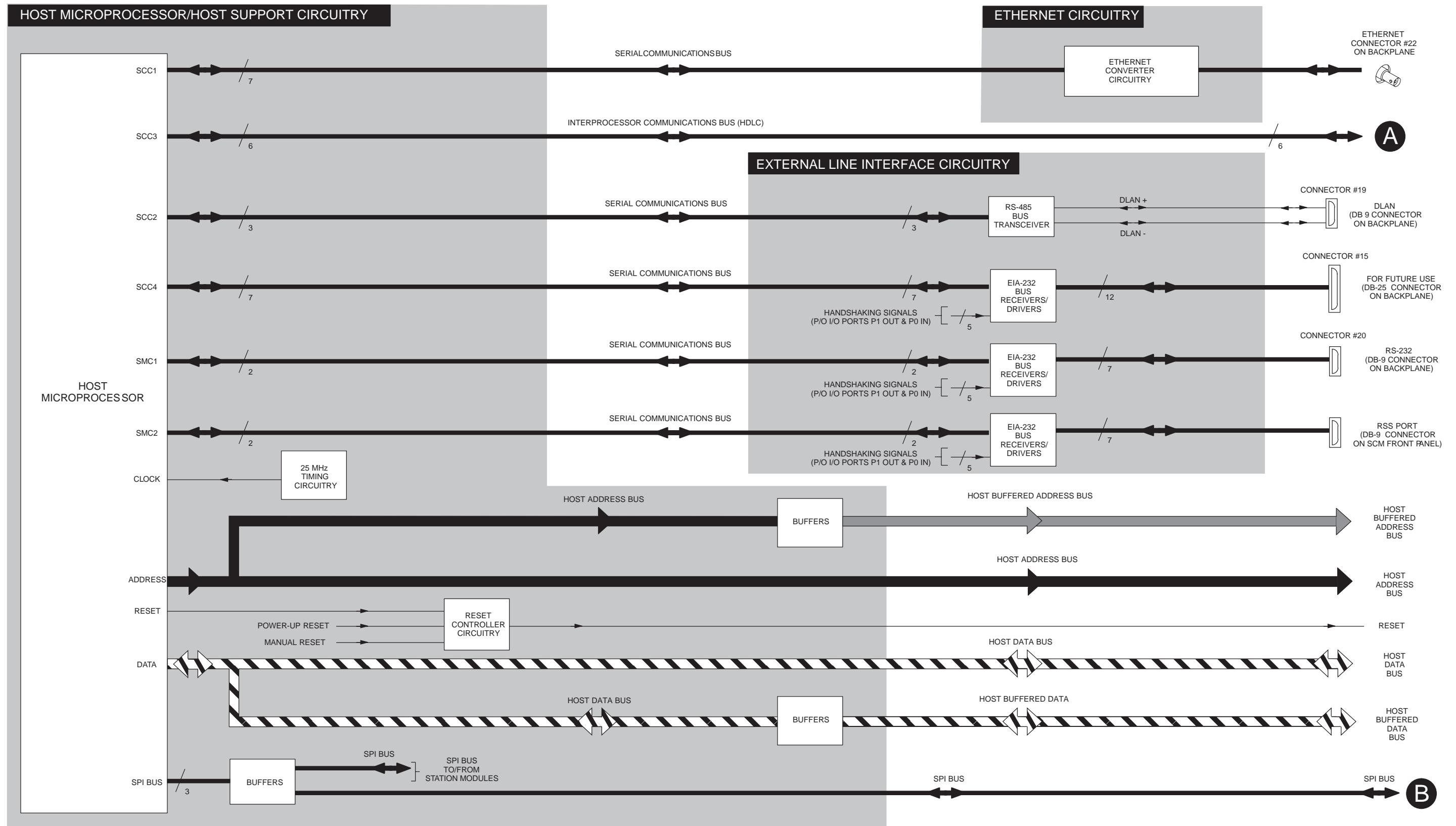

Figure 2 CLN8426A, CLN8447A Station Control Module Functional Block Diagram (1 of 5)

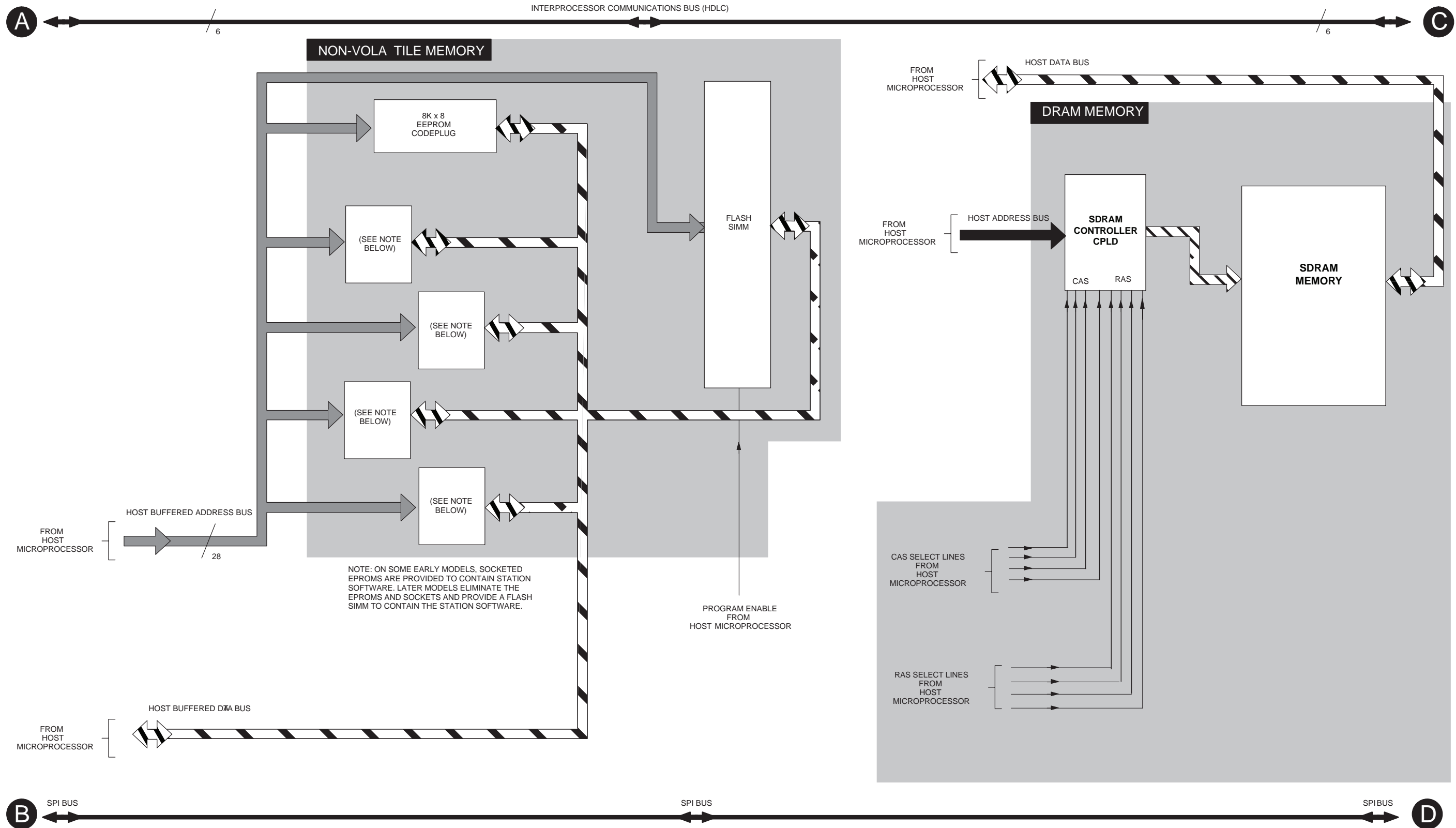

Figure 2 CLN8426A, CLN8447A Station Control Module Functional Block Diagram (2 of 5)

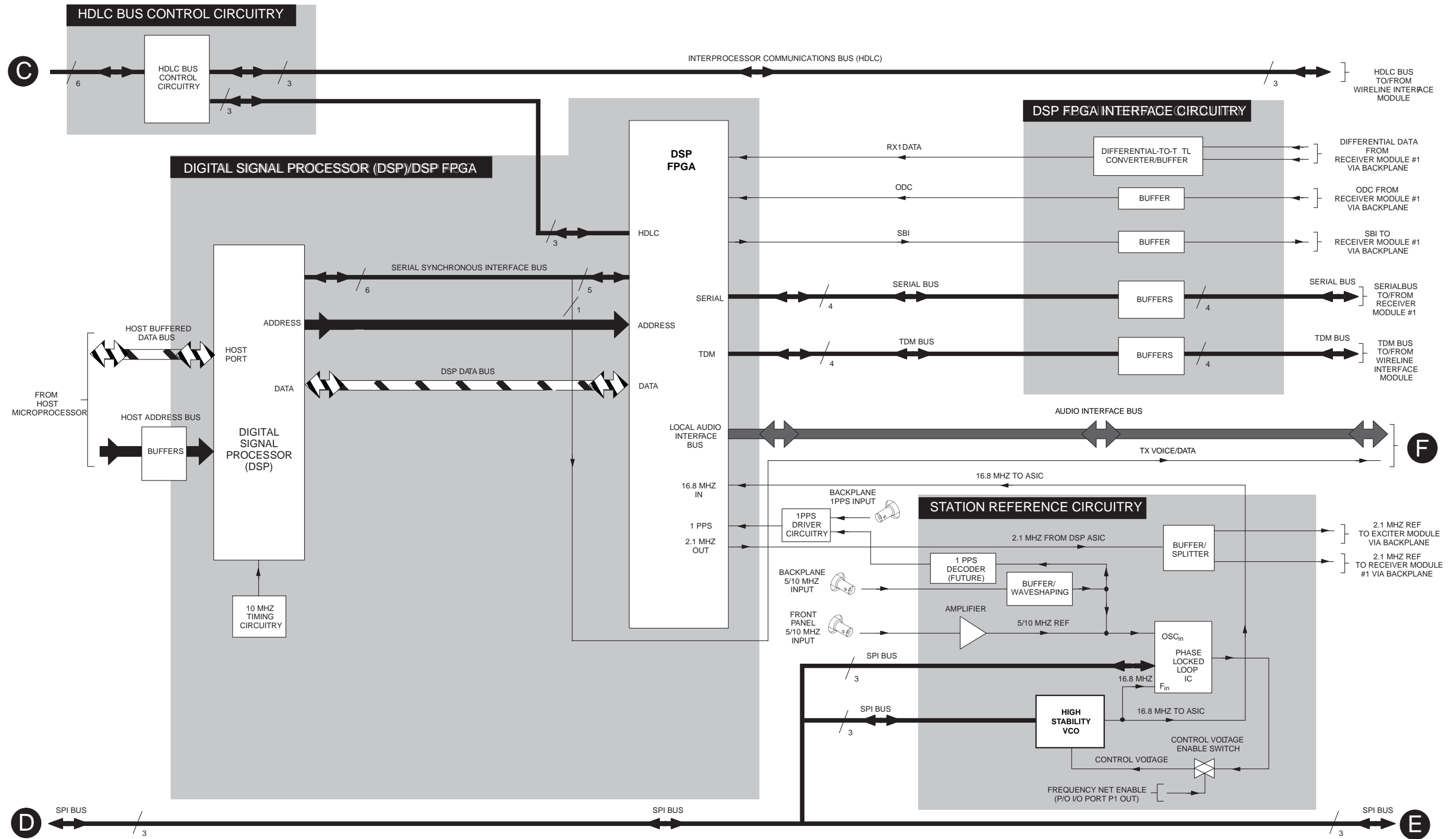

Figure 2 CLN8426A, CLN8447A Station Control Module Functional Block Diagram (3 of 5)

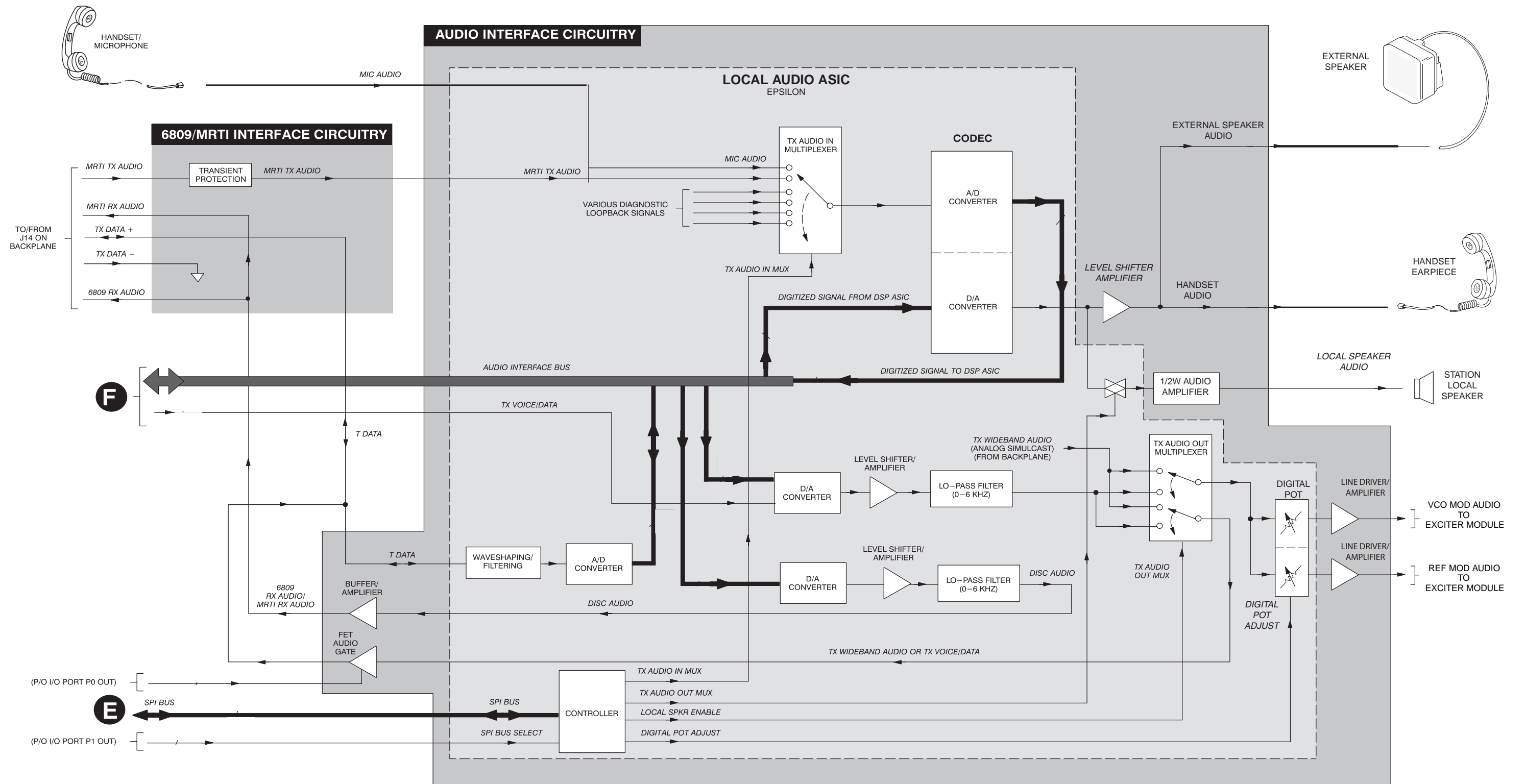

Figure 2 CLN8426A, CLN8447A Station Control Module Functional Block Diagram (4 of 5)

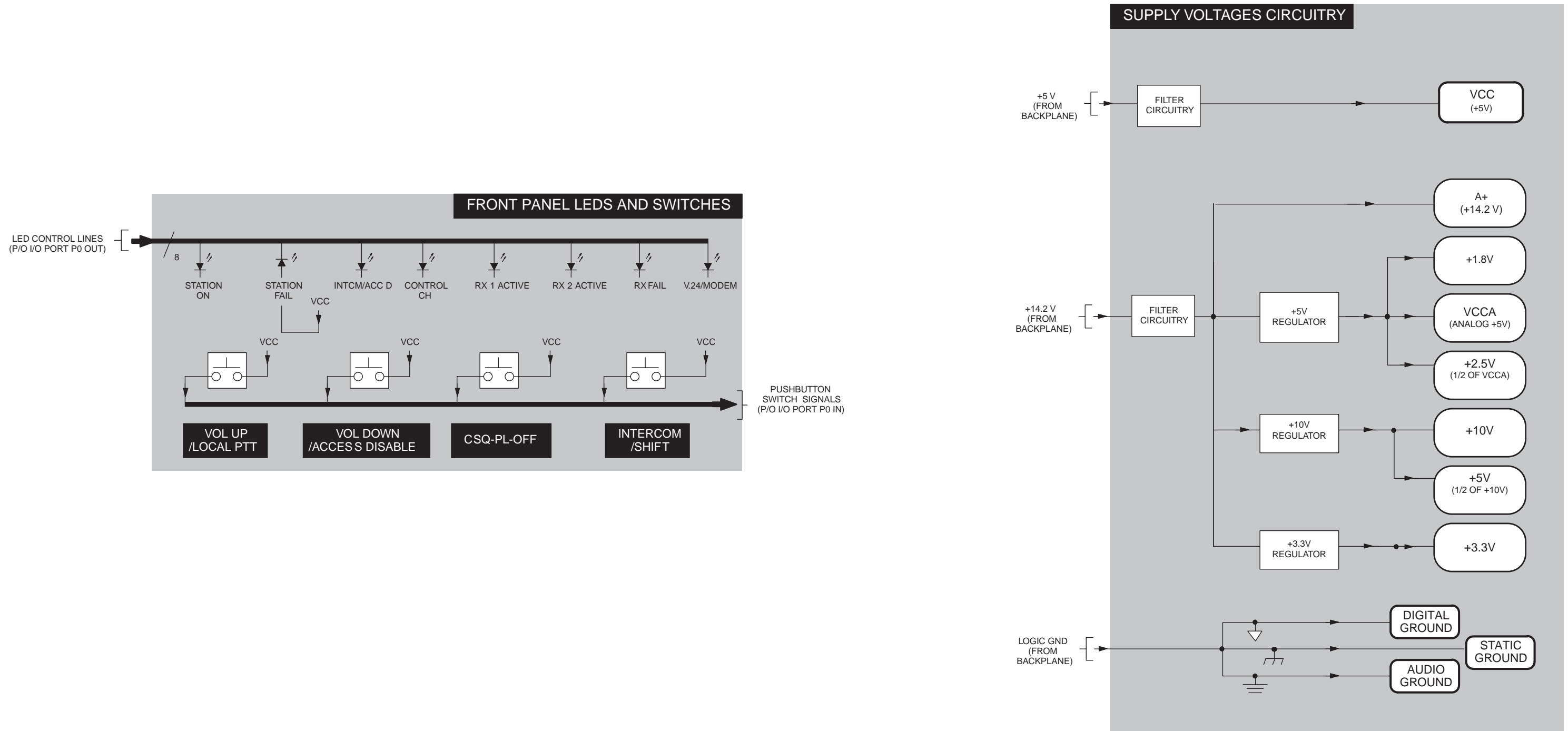

Figure 2 CLN8426A, CLN8447A Station Control Module Functional Block Diagram (5 of 5)

# Correction to SMR-6901

## 68P81095E05-D

### **Quantar™ Digital-Capable Station for Conventional, SECURENET, ASTRO®, 6809 Trunking, and IntelliRepeater Systems**

This revision is a correction to the information provided on the cover page of SMR-6901 regarding Quantar Digital-Capable Station, manual 68P81095E05-D. The model numbers for the older station control modules being replaced by the new models were inadvertently transposed in SMR-6901. The replacement pages included with SMR-6901 are correct as-is. Please retain this cover sheet with SMR-6901.

This correction **does not** apply to new base stations manufactured with the new station control modules CLN8426A or CLN8447A, and only applies to base stations in which older station control modules CLN6960 or CLN6961 may be replaced with the new station control modules.

The correction for the first paragraph under the heading for 68P81095E05-D on the SMR-6901 cover page is shown below. The portions requiring correction are shown in bold type.

#### **INCORRECT:**

Station control modules **CLN6960** and CLN1614 have been replaced by new model CLN8426A. Station control module **CLN6961** has been replaced by new model CLN8447A. The new modules are functionally identical to the assemblies they replace.

#### **CORRECT:**

Station control modules **CLN6961** and CLN1614 have been replaced by new model CLN8426A. Station control module **CLN6960** has been replaced by new model CLN8447A. The new modules are functionally identical to the assemblies they replace.