



MCR 100

Repeater (RT) Station

450-470 MHz

NOTE: The MCR100 Repeater appears to be identical to the Radius R100 Repeater. There are minor differences between this manual and the 6881078E15-O manual for the R100, but the sections covering the schematic diagrams and parts lists are the same in both manuals.

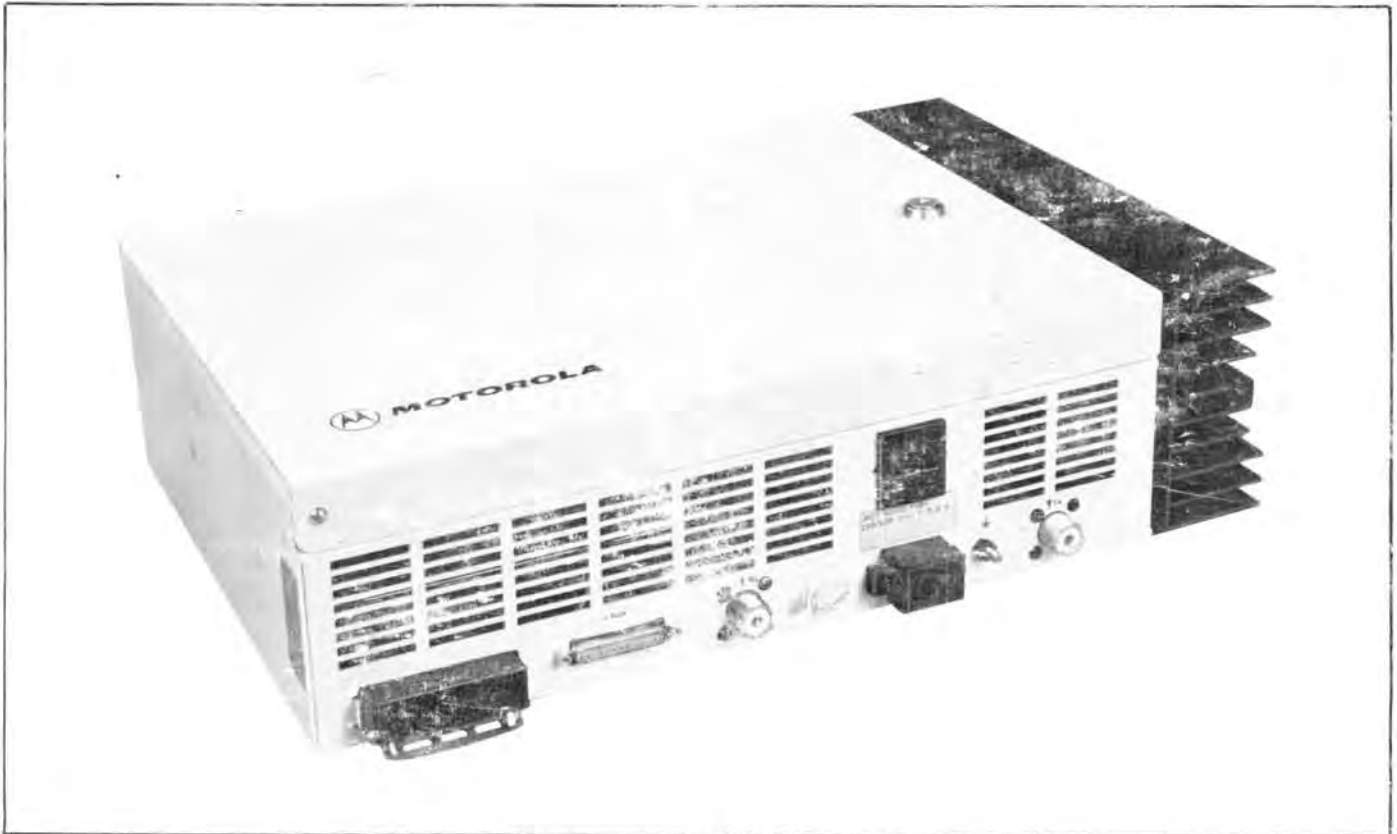

THIS MANUAL HAS BEEN
DISCONTINUED

Instruction Manual

68P81071E50-A



MOTOROLA INC.
Communications
Sector

MCR 100
REPEATER STATION
INSTRUCTION MANUAL
(450-470 MHz)

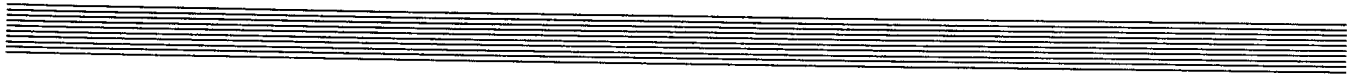

ATTACHMENTS

- Commercial Warranty and Computer Software Copyrights.....68P81112E94
- Model Chart.....Page 3
- Model Breakdown Chart.....Page 4
- Option Breakdown Chart.....Page 5
- Field Modification Kit Chart.....Page 5
- Performance Specifications.....Page 6
- General Safety Information.....EPS-28750
- Q2903A, Q2904A (25 Watt) and Q2931A, Q2932A (2-10 Watt) Repeater
(450-470 MHz) Station Instruction Manual.....1S-SP3670001

technical writing services
1301 E. Algonquin Road, Schaumburg, IL 60196

**COMMERCIAL WARRANTY
(STANDARD)**

Motorola radio communications products are warranted to be free from defects in material and workmanship for a period of ONE (1) YEAR, (except for crystals and channel elements which are warranted for a period of ten (10) years) from the date of shipment. Parts, including crystals and channel elements, will be replaced free of charge for the full warranty period but the labor to replace defective parts will only be provided for One Hundred-Twenty (120) days from the date of shipment. Thereafter purchaser must pay for the labor involved in repairing the product or replacing the parts at the prevailing rates together with any transportation charges to or from the place where warranty service is provided. This express warranty is extended by Motorola Communications and Electronics, Inc., 1301 E. Algonquin Road, Schaumburg, Illinois 60196, to the original purchaser only, and only to those purchasing for purpose of leasing or solely for commercial, industrial, or governmental use.

THIS WARRANTY IS GIVEN IN LIEU OF ALL OTHER WARRANTIES EXPRESS OR IMPLIED WHICH ARE SPECIFICALLY EXCLUDED, INCLUDING WARRANTIES OF MERCHANTABILITY OR FITNESS FOR A PARTICULAR PURPOSE. IN NO EVENT SHALL MOTOROLA BE LIABLE FOR INCIDENTAL OR CONSEQUENTIAL DAMAGES TO THE FULL EXTENT SUCH MAY BE DISCLAIMED BY LAW.

In the event of a defect, malfunction or failure to conform to specifications established by seller, or if appropriate, to specifications accepted by Seller in writing, during the period shown, Motorola, at its option, will either repair or replace the product or refund the purchase price thereof, and such action on the part of Motorola shall be the full extent of Motorola's liability hereunder.

This warranty is void if:

- a. the product is used in other than its normal and customary manner;
- b. the product has been subject to misuse, accident, neglect or damage;
- c. unauthorized alterations or repairs have been made, or unapproved parts used in the equipment.

This warranty extends only to individual products, batteries are excluded, but carry their own separate limited warranty. Because each radio system is unique, Motorola disclaims liability for range, coverage, or operation of the system as a whole under this warranty except by a separate written agreement signed by an officer of Motorola.

Non-Motorola manufactured products are excluded from this warranty, but subject to the warranty provided by their manufacturers, a copy of which will be supplied to you on specific written request.

In order to obtain performance of this warranty, purchaser must contact its Motorola salesperson or Motorola at the address first above shown, attention Quality Assurance Department.

This warranty applies only within the United States.

EPS-27734-O

COMPUTER SOFTWARE COPYRIGHTS

The Motorola products described in this instruction manual may include copyrighted Motorola computer programs stored in semiconductor memories or other media. Laws in the United States and other countries preserve for Motorola certain exclusive rights for copyrighted computer programs, including the exclusive right to copy or reproduce in any form the copyrighted computer program. Accordingly, any copyrighted Motorola computer programs contained in the Motorola products described in this instruction manual may not be copied or reproduced in any manner without the express written permission of Motorola. Furthermore, the purchase of Motorola products shall not be deemed to grant either directly or by implication, estoppel, or otherwise, any license under the copyrights, patents or patent applications of Motorola, except for the normal non-exclusive, royalty free license to use that arises by operation of law in the sale of a product.

EPS-34440-B

68P81112E94-B

MODEL CHART
MCR 100
2-10 and 25 WATT
450 - 470 MHz
25 kHz CHANNEL SPACED
REPEATER STATIONS

MODEL DESCRIPTION

Q2903A PL Squelch, Repeater Control Station; 25 W
 Q2904A DPL Squelch, Repeater Control Station; 25 W
 Q2931A PL Squelch, Repeater Control Station; 2-10 W
 Q2932A DPL Squelch, Repeater Control Station; 2-10 W

LEGEND:
 X = One Item Supplied

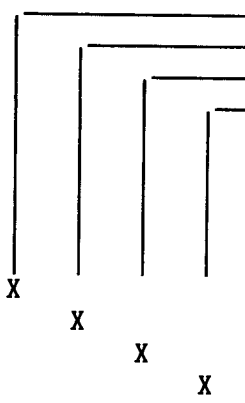

MODEL	DESCRIPTION
G1040A	PL Squelch, Repeater Control Chassis; 25 W
G1040A-SP500	DPL Squelch, Repeater Control Chassis; 25 W
G1046A	PL Squelch, Repeater Control Chassis; 2-10 W
G1046A-SP500	DPL Squelch, Repeater Control Chassis; 2-10 W

EPS-44049-A

**MODEL BREAKDOWN CHART FOR
MCR 100
2-10 and 25 WATT
450 - 470 MHz
25 kHz CHANNEL SPACED
REPEATER CHASSIS**

MODEL	DESCRIPTION
G1039A	PL Squelch, Tone Remote/Repeater Control Chassis; 25 W
G1039A-SP500	DPL Squelch, Tone Remote/Repeater Control Chassis; 25 W
G1040A	PL Squelch, Repeater Control Chassis; 25 W
G1040A-SP500	DPL Squelch, Repeater Control Chassis; 25 W
G1045A	PL Squelch, Tone Remote/Repeater Control Chassis; 2-10 W
G1045A-SP500	DPL Squelch, Tone Remote/Repeater Control Chassis; 2-10 W
G1046A	PL Squelch, Repeater Control Chassis; 2-10 W
G1046A-SP500	DPL Squelch, Repeater Control Chassis; 2-10 W

LEGEND:

X = One Item Supplied
2 = Number Of Items Supplied

KIT	DESCRIPTION
X X X X X X X X	GKN6163A Repeater Station Cables
X X X X X X X X	GKN6180A AC Power Cord; 110/120 Vac; 3-Wire
X X X X X X X X	GLE6142A RF Board; 25 kHz Channel Space, 5 PPM
X X X X X X X X	GLE6176A TX Board; 2 PPM, 438-470 MHz
X X X X X X X X	GLE6180A PA; 1-10 Watt, 438-470 MHz
X X X X X X X X	GLE6181A PA; 25 Watt, 438-470 MHz
X X X X X X X X	GLE6182A UHF Receive Low Pass Filter
X X X X X X X X	GLN6768A Tone Remote/Repeater Control Board
X X X X X X X X	GLN6770A Repeater Hardware
2 2 2 2 2 2 2 2	GLN6808A RF Chassis Hardware
X X X X X X X X	GLN6810A Receiver PL Command Board
X X X X X X X X	GLN6810A-SP500 Receiver DPL Command Board
X X X X X X X X	GLN6811A Transmitter PL Command Board
X X X X X X X X	GLN6811A-SP500 Transmitter DPL Command Board
X X X X X X X X	GLN6815A Repeater Control Board
X X X X X X X X	GLN6861A Wall Mount Hardware
2 2 2 2 2 2 2 2	GLN6880A Repeater PROM
X X X X X X X X	GLN6898A 10 Watt DC Interconnect Board
X X X X X X X X	GLN6899A 25 Watt Current Limiter Board
X X X X X X X X	GLN6904A Fuse; 110/120 Vac, 10 Watt TX
X X X X X X X X	GLN6905A Fuse; 110/120 Vac, 25 Watt TX
X X X X X X X X	GPN1009A Battery Revert Power Supply; 10 W includes: GLN6780A Battery Revert Regulator Board GLN6814A 10 Watt Battery Revert Heatsink Hardware
X X X X X X X X	GPN1010A Battery Revert Power Supply; 25 W includes: GLN6780A Battery Revert Regulator Board GLN6813A 25 Watt Battery Revert Heatsink Hardware

EPS-44050-0

**OPTION
BREAKDOWN CHART
FOR
MCR 100
REPEATER STATIONS**

OPTION	ADD	DELETE	DESCRIPTION
*L75AA-SP Omit Time-Out Timer Function	---	---	
L141AA-SP Extended Local Control (ELC)	QKN4012A QKN4013A QRN4314A QRN4324A	---	Station Interface Cabling Kit External ELC Connector Kit Interface Board Kit RPTR Control Board Modification Kit
L141AB-SP ELC for Phone Patch (PP)	QKN4014A QKN4016A QRN4324A	---	External PP Cable Modification Kit External PP ELC Connector Kit RPTR Control Board Modification Kit
*L143AG-SP Remote Repeater Control	---	---	Function Tone Decode Added; 1450 Hz for RPTR Set-Up and 1550 Hz RPTR KD
L168AK-SP PL Tone Remote Control	G1039A	G1040A	PL Tone Remote/RPTR Control Chassis PL Repeater Control Chassis
L168AL-SP DPL Tone Remote Control	G1039A-SP500	G1040A-SP500	DPL Tone Remote/RPTR Control Chassis DPL Repeater Control Chassis
L168AM-SP PL Tone Remote Control	G1045A	G1046A	PL Tone Remote/RPTR Control Chassis PL Repeater Control Chassis
L168AN-SP DPL Tone Remote Control	G1045A-SP500	G1046A-SP500	DPL Tone Remote/RPTR Control Chassis DPL Repeater Control Chassis
L301AA Service Handset	TMN6164A	---	With PTT switch
*L405AA-SP Omit PL SQ	---	---	Enable Carrier SQ Only Operation
L658AA-SP External Duplexer RF Cabling	QKN4026A	---	Duplexer Cable Kit; 2 used
*L719AB-SP PP Interface	QKN4012A QRN4314A	---	Station Interface Cabling Kit Interface Board Kit
L933AB-SP Add Service Speaker	TSN6030A-SP100	---	External Speaker Kit

*Requires Code Plug Change

**FIELD MODIFICATION KIT CHART
FOR
MCR 100
REPEATER STATIONS**

MODIFICATION KIT	ADD	DESCRIPTION
QLN3068A RCVR Code Plug	GLN6880A	Repeater Receive Code Plug; Programmed
QLN3069A XMTR Code Plug	GLN6880A	Repeater Transmit Code Plug; Programmed

**PERFORMANCE SPECIFICATIONS
FOR
MCR 100
REPEATER STATIONS**

GENERAL	Frequency range	450-470	MHz
	Channel spacing	25	kHz
	Mode of operation	Duplex	
	Number of channels	1	
	Modulation	16F3	
	Antenna impedance	50	ohms
	Operating temperature	-25 to +55	°C
	Dimensions HxWxD	16.9x10.8x4.7 (275x430x120 mm)	in
	Weight (standard models)	26 (12 kg)	lbs
	TRANSMITTER	RF output	Q2903A, 04A 25
Frequency Stability		2	ppm
Maximum deviation		±5	kHz
Harmonics		<1	uW
Spurious		<1	uW
Audio response		According to EIA regulations	
Distortion (max)		<3	%
Adj channel power		>70	dB
Duty cycle		Intermittent duty (1:4): -25 to +55°C. 30 mins. continuous transmit: (25 W ≤ +40°C). If limits are exceeded, power cutback will automatically occur to ensure safe operation.	
RECEIVER		Sensitivity (12 dB SINAD)	<0.35
	Adj channel selectivity	>75	dB
	Image rejection	>80	dB
	Spurious rejection	>80	dB
	Intermodulation	>76 (uVemf)	dB
	Spurious emissions	<2	nW
	Audio output	+11 max into 600 ohms	dBm
	Audio response	According to EIA regulations	
Distortion	<3	%	
POWER SUPPLY	Nominal voltage (60 Hz)	Q2903A, 04 110/120	Q2931A, 32A 110/120 V
	120 V ac power - Standby	36	36 W
AC LINE	- Transmit	360	150 W
	AC input current	3	1.25 A
12 V BATTERY	Current drain - Standby	0.75	0.75 A
	- Receive	1.4	1.4 A
	- Transmit	8.75	3.9 A



MOTOROLA INC.
Communications
Sector

GENERAL SAFETY INFORMATION

The United States Department of Labor, through the provisions of the Occupational Safety and Health Act of 1970 (OSHA), has established an electromagnetic energy safety standard which applies to the use of this equipment. Proper use of this radio will result in exposure below the OSHA limit. The following precautions are recommended:

DO NOT operate the transmitter of a mobile radio when someone outside the vehicle is within two feet (0.6 meter) of the antenna.

DO NOT operate the transmitter of a fixed radio (base station, microwave and rural telephone rf equipment) or marine radio when someone is within two feet (0.6 meter) of the antenna.

DO NOT operate the transmitter of any radio unless all RF connectors are secure and any open connectors are properly terminated.

In addition,

DO NOT operate this equipment near electrical caps or in an explosive atmosphere.

All equipment must be properly grounded according to Motorola installation instructions for safe operation.

All equipment should be serviced only by a qualified technician.

Refer to the appropriate section of the product service manual for additional pertinent safety information.

EPS-28750-A

technical writing services

1301 E. Algonquin Road, Schaumburg, IL 60196



MOTOROLA INC.
 Communications
 Sector

MODELS Q2903A, Q2904A
 (25 WATT)
 MODELS Q2931A, Q2932A
 (2-10 WATTS)
 UHF REPEATER STATIONS
 (450-470 MHz)



1. CONTENTS

DESCRIPTION

-- Description.....Page 4
 -- Specialized Kit Description.....Page 5
 G1039A-SP500 and G1045-SP500 DPL Tone Remote/RPTR Control Chassis....Page 5
 G1040A-SP500 and G1046-SP500 DPL Repeater Control Chassis.....Page 5
 GLN6810A-SP500 Receive DPL Command Board.....Page 5
 GLN6811A-SP500 Transmit DPL Command Board.....Page 6
 TSN6030A-SP100 External Speaker.....Page 6
 QKN4012A Station Interface Cabling Kit.....Page 6
 QKN4013A External ELC Connector Kit.....Page 6
 QKN4014A External Phone Patch (PP) Cable Modification Kit.....Page 6
 QKN4016A External PP ELC Connector Kit.....Page 7
 QKN4026A Duplexer Cable Kit.....Page 7
 QRN4314A Interface Board.....Page 7
 QRN4324A TRC/RPTR Board Modification Kit.....Page 10
 -- Major Station Components.....Page 10
 Transmitter Section.....Page 11
 Receiver Section.....Page 12
 Control Section.....Page 12
 Power Supply Section.....Page 13

technical writing services

1301 E. Algonquin Road, Schaumburg, Il. 60196

INSTALLATION

--	Installation.....	Page 16
	Introduction.....	Page 16
	Ventilation.....	Page 16
	Station Mounting Procedures.....	Page 16
	Antenna Connections.....	Page 17
	Power and Ground Connections.....	Page 18
	General.....	Page 18
	AC Input Power.....	Page 18
	DC Input Power.....	Page 18
	Control Line Connections and Level Settings.....	Page 19
	General.....	Page 19
	Wire Line Specifications.....	Page 19
	Control Line Level Adjustment.....	Page 20
	Jumpering Information.....	Page 21
	Tone Remote/RPTR Control Board Jumpers.....	Page 21
	Command Board Jumpers.....	Page 22

MAINTENANCE

--	Maintenance.....	Page 24
	General.....	Page 24
	Local Service Operation.....	Page 24
	Recommended Service Equipment.....	Page 25
	Tone Remote/RPTR Control Board Alignment.....	Page 27
	RF Adjustments.....	Page 29
	Disassembly and Service Access.....	Page 35

DIAGRAMS and PARTS LISTS

--	QRN4314A Interface Board Schematic Diagram and Circuit Board Detail.....	2-SP3760001
--	QRN4314A Parts List.....	2PL-SP3760001
--	QRN4314A Interface Board Block Diagram.....	3-SP3760001
--	QKN4012A Station Interface Cabling Kit Parts List.....	3PL-SP3760001
--	External Connectors Assembly Diagram.....	4-SP3760001
--	QKN4013A External Extended Local Control (ELC) Connector Kit Parts List.....	4PL-SP3760001
--	QKN4014A External Phone Patch (PP) Cable Modification Kit Parts List.....	6PL-SP3760001
--	QKN4016A External PP ELC Connector Kit Parts List.....	7PL-SP3760001
--	QKN4026A Duplexer Cable Kit Parts List.....	8PL-SP3760001
--	Station Exploded View Diagram.....	9-SP3760001
--	Station Exploded View Parts List.....	9PL-SP3760001
--	Station Overall Block Diagram	11-SP3760001
--	Repeater Receive Block Diagram	12-SP3760001
--	Repeater Transmit Block Diagram	13-SP3760001
--	GLE6182A UHF Receiver Low Pass Filter Circuit Board Details	14-SP3760001

--	GLE6182A Parts List.....	14PL-SP3760001
--	GKN6162A Base Station Cable and GKN6163A Repeater Station Cable Parts List.....	16PL-SP3760001
--	GKN6180A 110/120 V AC Power Cable Parts List.....	17PL-SP3760001
--	GLN6904A 10 W Transmit Fuse Parts List.....	18PL-SP3760001
--	GLN6905A 25 W Transmit Fuse Parts List.....	19PL-SP3760001
--	GLN6879A Base Station PROM Kit and GLN6880A Repeater Station PROM Kit Parts List.....	21PL-SP3760001
--	GLN6808A Chassis Hardware Parts List.....	22PL-SP3760001
--	GLN6770A Repeater Hardware Parts List.....	23PL-SP3760001
--	GLN6861A Wall Mount Hardware Parts List.....	24PL-SP3760001
--	Tone Remote/RPTR Control Board Block Diagram.....	26-SP3760001
--	GLN6768A and GLN6815A Tone Remote/RPTR Control Board Schematic Diagram, Circuit Board Details, and Theory Notes.....	27-SP3760001
--	GLN6768A Parts List.....	28PL-SP3760001
--	GLN6815A Parts List.....	29PL-SP3760001
--	GLN6810A Receive Command Board Schematic Diagram and Circuit Board Details.....	31-SP3760001
--	GLN6810A Parts List.....	31PL-SP3760001
--	GLN6811A Transmit Command Board Schematic Diagram and Circuit Board Details.....	32-SP3760001
--	GLN6811A Parts List.....	32PL-SP3760001
--	GLE6142A RF Board; 438-470 MHz; 25 kHz; 5 PPM Schematic Diagram and Circuit Board Details.....	33-SP3760001
--	GLE6142A Parts List.....	33PL-SP3760001
--	GLE6174A (403-433 MHz) and GLE6176A (438-470 MHz) Transmit RF Board; 2 PPM Schematic Diagram and Circuit Board Details.....	34-SP3760001
--	GLE6174A Parts List.....	34PL-SP3760001
--	GLE6180A 10 W PA Assembly (438-470 MHz) and GLN6898A 10 W DC Interconnect Board Schematic Diagram, and 10 W PA Circuit Board Details.....	36-SP3760001
--	GLE6180A Parts List.....	36PL-SP3760001
--	GLN6898A 10 W DC Interconnect Board Circuit Board Detail.....	37-SP3760001
--	GLN6898A Parts List.....	37PL-SP3760001
--	GLE6181A 25 W PA Assembly (438-470 MHz) and GLN6899A 25 W Current Limiter Board Schematic Diagram, and 25 W PA Circuit Board Details.....	38-SP3760001
--	GLE6179A Parts List.....	38PL-SP3760001
--	GLN6899A 25 W Current Limiter Board Circuit Board Details.....	39-SP3760001
--	GLN6899A Parts List.....	39PL-SP3760001
--	GPN1009A and GPN1010A Battery Revert Power Supply (includes: GLN6780A Battery Revert Regulator Board) Schematic Diagram and Circuit Board Detail.....	41-SP3760001
--	GLN6780A Parts List.....	41PL-SP3760001
--	GLN6814A 10 W Battery Revert Hardware Parts List (p/o GPN1009A 10W Battery Revert Power Supply).....	42PL-SP3760001
--	GLN6713A 25 W Battery Revert Hardware Parts List (p/o GPN1010A 25 W Battery Revert Power Supply).....	43PL-SP3760001
--	Lightning Protection Recommendations.....	68P81111E17

2. DESCRIPTION

The information presented in this manual describes the Q2903A, Q2904A, Q2931A, and Q2932A UHF Repeater Stations (see Figure 1) and the kits required for their Options. Refer to the Model and Model Breakdown Chart, at the beginning of this manual, to determine the kits used in the assembly of these Stations. Refer to the Options Breakdown chart, also at the beginning of this manual, to determine the kits required for Station Options.

The stations are complete 25 W (Q2903A, 04A) or 2-10 W (Q2931A, 32A), stand alone (non-wireline), single frequency repeaters which operate at 450-470 MHz, with 2 PPM transmit frequency stability. Various options are available to enhance their capabilities and provide for ease of maintenance. The Q2903A, Q2904A, Q2931A, and Q2932A stations chassis components are installed, maintained, and aligned as described in the following paragraphs. A number of specialized kits are used to implement carrier, Private-Line™, or Digital Private-Line™ squelch operation and provide interface with equipment located external to the station. These items are described in the following specialized kit paragraphs.

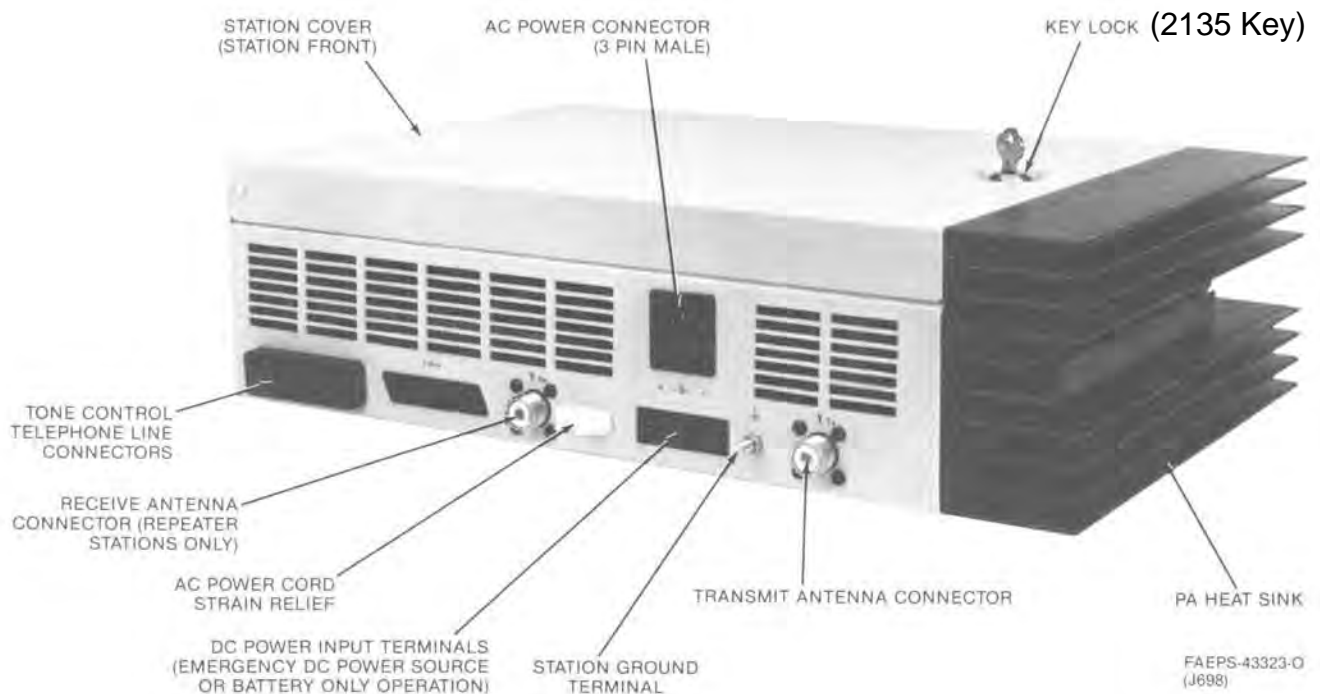

Figure 1. Overall Station View

IMPORTANT

In very rare cases, harmonics of the command board microprocessor clock frequency (4.9248 MHz) will couple back to the receiver, causing self-quieting to a limited degree. In the event that receiver self-quieting is observed, clip out jumper JU707 on BOTH of the command boards. Jumper JU707 is located between the microprocessor (U701) and the crystal (Y701) on each of the command boards. The transmit command board is accessible when opening the repeater door. The receive command board is accessible after removing the receiver subassembly. The removal of JU707 will slightly shift the microprocessor clock frequency. If the self-quieting does not cease, then contact an authorized Motorola Service Shop.

3. SPECIALIZED KIT DESCRIPTION

3.1 G1039A-SP500 and G1045A-SP500 DPL TONE REMOTE/RPTR CONTROL CHASSIS

The SP500 Tone Remote/RPTR Control Chassis are the DPL squelch versions of the PL squelch tone remote/RPTR control chassis (Models G1039A and G1045A). They use the DPL version, rather than the PL version, of the transmit and receive command boards.

3.2 G1040A-SP500 and G1046A-SP500 DPL REPEATER CONTROL CHASSIS

The SP500 Repeater Control Chassis are the DPL squelch versions of the PL squelch repeater controlled chassis (Models G1040A and G1046A). They use the DPL version, rather than the PL version, of the transmit and receive command boards.

3.3 GLN6810A-SP500 RECEIVE DPL COMMAND BOARD

The GLN6810A-SP500 Receive DPL Command Board is the same as described for the Model GLN6810A Receive PL Command Board elsewhere in this instruction manual, except that the microprocessor (U701) is exchanged for one (Motorola Part No. 5106370M17) properly programmed for DPL operation. Also, signal coupling and decoupling capacitors C551, C562, and C811 are changed for correct DPL operation, as follows:

C551 is changed to a 33 uF $\pm 20\%$, 25 V unit (Motorola Part No. 2311019A33);
C562 is changed to a 100 uF $\pm 20\%$, 25 V unit (Motorola Part No. 2311019A46);
C811 is changed to a 1 uF $\pm 20\%$, 50 V unit (Motorola Part No. 2311019A09).

3.4 GLN6811A-SP500 TRANSMIT DPL COMMAND BOARD

The GLN6811A-SP500 Transmit DPL Command Board is the same as described for the Model GLN6811A Transmit PL Command Board elsewhere in this instruction manual, except that the microprocessor (U701) is exchanged for one (Motorola Part No. 5106370M17) properly programmed for DPL operation. Also, signal coupling capacitor C607 is changed for correct DPL operation, as follows:

C607 is changed to a 100 uF $\pm 20\%$, 25 V unit (Motorola Part No. 2311019A46).

3.5 TSN6030A-SP100 EXTERNAL SPEAKER

The TSN6030A-SP100 External Speaker is the same as described for the Model TSN6030A in its accompanying instruction section 68P81109E24, except that its two connecting cable contacts have been changed to those required for proper connection to a Q2903A, Q2904A, Q2931A, or Q2932A Station. The Motorola Part No. of the required contact is 3984257L02.

3.6 QKN4012A STATION INTERFACE CABLING KIT

The QKN4012A Station Interface Cable Kit consists of two cables. One, connected to the tone remote/RPTR control board at fourteen signal points, routes those signals to the interface board via P2. The other, designated W1, routes the signals out of the interface board, via P3, to the chassis mounted 25-pin, D-type connector designated Jaux. Both cables are illustrated on the attached QRN4314A Interface Board schematic diagram 2-SP3760001. Refer to the attached parts list 3PL-SP3760001 for the interface cabling kit components.

3.7 QKN4013A EXTERNAL EXTENDED LOCAL CONTROL CONNECTOR KIT

Whenever extended local control (ELC) is desired, a Model T1370 ELC Desk Set is connected to the Q2903A, Q2904A, Q2931A, or Q2932A Station, with a customer provided cable. The customer provided cable should be soldered to a 25-pin D-type connector provided in the QKN4013A External ELC Connector Kit, as per Figure A of the attached External Connectors Assembly Diagram 4-SP3760001. The desk set end of the cable should be constructed as per directions provided in the Model T1370 ELC Desk Set (or other equivalent Desk Set) Instruction manual 68P81115A05.

3.8 QKN4014A EXTERNAL PHONE PATCH CABLE MODIFICATION KIT

Whenever ELC is desired in addition to a radiotelephone interconnect (Phone Patch or PP), the factory provides a modified external PP cable, which is to be connected between the external PP equipment and Jaux. The QKN4014A kit contains a short cable which is connected to appropriate pins in the existing PP cable's 25-pin D-type connector, at the Jaux end of the PP cable, as shown in Table 1. The modification configures the existing signal lines in parallel, making the external PP cable capable of connecting to both external phone patch equipment and an ELC desk set.

Table 1. External PP Cable ELC Modification

TYPE-D PIN	WIRE COLOR	DESK SET SIGNAL DESCRIPTION	BLOCK PIN
14	GRN-WHT	GND	9
15	WHT-BRN	Speaker Hi	11
16	VIO	Mic Hi	8
17	BLK-WHT	Mic GND	10
18	BLU-YEL	PL Disable	7
19	ORG	PTT	4
20	GRY	RPTR Knockdown	5

3.9 QKN4016A EXTERNAL PP ELC CONNECTOR KIT

Whenever ELC is desired in addition to a radiotelephone interconnect (Phone Patch or PP), the factory provides a modified external PP cable, as described in the previous paragraph. The customer must provide a cable to connect the Model T1370 ELC Desk Set (or equivalent) to the added connector. This cable should be constructed using the 15-pin connector provided in the QKN4016A External PP ELC Connector Kit, as per Figure B of the attached External Connectors Assembly Diagram 4-SP3760001. The desk set end of the cable should be constructed as per directions provided in the Model T1370 ELC Desk Set (or equivalent) Instruction manual 68P81115A05.

3.10 QKN4026A DUPLEXER CABLE KIT

The QKN4026A Duplexer Cable Kit provides a length of rf cable, with the proper connectors assembled to it, to route either the transmit or the receive signal, via an external Model TDN7407 Duplexer, to the Q2903A, Q2904A, Q2931A, or Q2932A Station. Normally, two cable kits are required at an installation site.

3.11 QRN4314A INTERFACE BOARD

3.11.1 Theory Of Operation

The QRN4314A Interface Board provides the circuitry required to connect a Model TDN7406 Phone Patch and/or a suitable Local Desk set to an Q2903A, Q2904A, Q2931A, or Q2932A Station. The circuitry can be divided into two functional sections: 1) The Phone Patch Interface; and, 2) The Desk set Interface. Refer to the attached QRN4314A Schematic diagram 2-SP3760001 and Block Diagram 3-SP3760001 throughout this description.

3.11.2 Phone Patch Interface

The phone patch interface circuitry is divided into several functional blocks as follows:

1. Squelch Control
2. Alert Inhibit Control
3. Exciter Audio Buffer
4. Inhibit Control
5. Local Repeater Control
6. Patch Audio Buffer
7. PTT Control

3.11.2.1 Squelch Control

The unsquelch control input to the phone patch controls the phone line audio direction. When the UNSQUELCH output signal is inactive (open-collector), then landline audio is sent to the repeater. When a mobile operator, wireline dispatcher, or local serviceman initiates a transmission, then the UNSQUELCH output switches low. The phone patch then mutes the landline-to-repeater audio path (AUDIO FROM PATCH), while completing the repeater-to-landline audio path (AUDIO TO PATCH). The squelch control circuitry is essentially a 4-input OR gate with negative logic (Local PTT, Guard Tone Detect, Rx Carrier Indicate, or Desk Set PTT). When any of the four inputs goes low, the output (UNSQUELCH) also goes low.

3.11.2.2 Alert Inhibit Control

The alert inhibit control input to the phone patch is simply an inverting logic buffer that prevents the phone patch from transmitting an alert tone when the station is already in use. When the station is keyed from the repeater, local microphone, or wireline, the PTT input goes high, causing the ALERT INHIBIT output to switch low.

3.11.2.3 Exciter Audio Buffer

The exciter audio buffer consists of an emitter-follower circuit (Q11) used to couple exciter audio to the phone patch. Exciter audio is the summation of local microphone audio, receiver audio, wireline audio and/or local desk set audio. During a normal landline/mobile conversation, exciter audio is passed through to the phone line when the phone patch UNSQUELCH input is low.

3.11.2.4 Inhibit Control

The inhibit control circuit provides a switched ground output (INHIBIT) to the phone patch when the repeater is knocked down. If the output from the Local Repeater Control circuit goes low (LOCAL RPTR DISABLE), or LINE RPTR DISABLE input goes low, then the INHIBIT output to the phone patch switches low. This action prevents all mobile-to-landline calls and disables the landline-to-mobile alert tone.

3.11.2.5 Local Repeater Control

The local repeater control circuit performs two functions: 1) It provides an active low output to the phone patch Inhibit Control circuit; and, 2) It provides a switched-ground output to the repeater control circuitry in the repeater. When either a Desk Set RPTR KD signal (active low) or a LOCAL RPTR DISABLE input from the TRC/RPTR board (active low) is received, then a grounded output is generated for the inhibit control circuit to disable the phone patch. In addition, when a Desk Set RPTR KD input is received, the LOCAL RPTR DISABLE input/output signal is pulled low, forcing the repeater into a knocked-down state.

3.11.2.6 Phone Patch Audio Buffer

The patch audio buffer circuit provides an interface between the landline-to-mobile audio input signal (AUDIO FROM PATCH) and the output audio signals to the repeater. This audio input signal drives three different circuits on the TRC/RPTR board: 1) local speaker audio (LOCAL AUDIO); 2) wireline audio (LINE AUDIO); and, transmitter audio (EXCITER AUDIO). The AUDIO FROM PATCH provides a 600 input impedance, and should be driven at a level of 315 ± 50 mVrms.

3.11.2.7 PTT Control (Phone Patch)

The PTT Control circuit is used by both the phone patch and by the local desk set to key the transmitter. The PATCH PTT input goes low during the generation of the phone patch alert tone, as well as when the patch is set up. The DESK SET PTT input goes low whenever the desk set PTT button is depressed. The audio to be transmitted is applied to the proper QRN4314A Interface Board input while the PTT input is present. (To the AUDIO FROM PATCH input for a PATCH PTT, or to the MIC AUDIO input for a DESK SET PTT.)

3.11.3 Desk set Interface

The desk set interface circuitry is divided into several functional blocks as follows:

1. PTT Control
2. Desk set Repeater Knockdown
3. PL Disable Control
4. Speaker Audio
5. Microphone Audio Buffer

3.11.3.1 PTT Control (Desk Set)

This circuitry is shared by the phone patch PTT Control circuit. Refer to the previous PTT CONTROL (Phone Patch) paragraph for further details.

3.11.3.2 Desk Set Repeater Knockdown

This active-low input is intended to be used to provide remote repeater control to a desk set capable of providing a switched ground or relay closure output. Grounding the RPTR KD input will disable the repeat function. Refer to the previous LOCAL REPEATER CONTROL paragraph for further details.

3.11.3.3 PL Disable Control

This circuit (Q10) is essentially a buffer interface between the desk set PL MONITOR signal) and the repeater PL DISABLE signal. When the PL MONITOR input is pulled low, the PL DISABLE output is switched low, causing the desk set and/or local speaker to unmute whenever an on-carrier signal is detected, regardless of the presence of a proper PL or DPL code.

3.11.3.4 Speaker Audio

The SPEAKER AUDIO signal provides a one-half watt audio signal (into 4 or 8 ohms) to the local desk set. The desk set's speaker is connected in parallel with the local speaker output (P2-2) on the TRC/RPTR board. As a result, for maximum audio output at the desk set, disconnect the station's local speaker when its not in use. Since the local speaker volume control, R818, on the TRC/RPTR board also controls the desk set speaker, it is recommended that R818 be adjusted for near maximum audio output. The desk set volume control may then be used to adjust the audio level at the desk set for a comfortable level.

3.11.3.5 Microphone Audio Buffer

This circuit provides a signal pull-up to the A+ supply and a 560 ohm input impedance to the MIC HI input from the desk set. The buffered MIC AUDIO signal is then routed to the EXCITER AUDIO output to be transmitted. The MIC AUDIO input signal is NOT coupled back to the local or desk set speakers.

3.11.4 Installation

The QRN4314A Interface Board is installed in an Q2903A, Q2904A, Q2931A, and Q2932A Station by plugging its J1 connector into the TRC/RPTR board's J6 receptacle, and connecting the QKN4012A Station Interface Cables to the interface board as shown on attached schematic diagram 2-SP3760001.

NOTE

The 9-pin J1 connector of the interface board plugs into the 11-pin J6 receptacle, pin-1 to pin-1. However, only pin-2 of either connector is used as an electrical connection (GND). The other pins provide mechanical support only. If the interface board is not installed properly, it will simply not function.

3.12 QRN4324A RPTR CONTROL BOARD MODIFICATION KIT

The QRN4324A kit consists of a silicon diode (Motorola Part No. 4883654H01) that is designated CR810. Diode CR810 is added to the GLN6815A Repeater Control board to enable the power-on reset of the PL Disable flip-flop circuit (U829C, D). The enabling of the control board's PL Disable power-on reset circuit is required for the proper operation of all Q2903A, Q2904A, Q2931A, and Q2932A Stations.

4. MAJOR STATION COMPONENTS

The major components of any station consist of a frequency generation section for transmit rf and receiver injection, a transmitter section, a receiver section, a control section, a power supply, a housing, and internal cabling. In repeater stations, a separate frequency generation section is provided for the transmitter as well as the receiver, the transmitter and receiver components are also specially shielded, and separate antenna connections are provided to prevent desensing problems. These major components are described as follows. See Figure 2.

4.1 TRANSMITTER SECTION

4.1.1 Frequency Synthesizer

These repeater stations have two frequency synthesizers used to provide the basic transmit operating frequency and the receiver injection signal. The transmit frequency synthesizer is part of the RF board mounted in the same "H" frame chassis as the transmitter. The receive frequency synthesizer is located, along with the receiver, in a separate, shielded rf box. This prevents desense problems, since both the transmitter and receiver are operating simultaneously in repeater stations. Each synthesizer has a separate VCO and reference oscillator circuit.

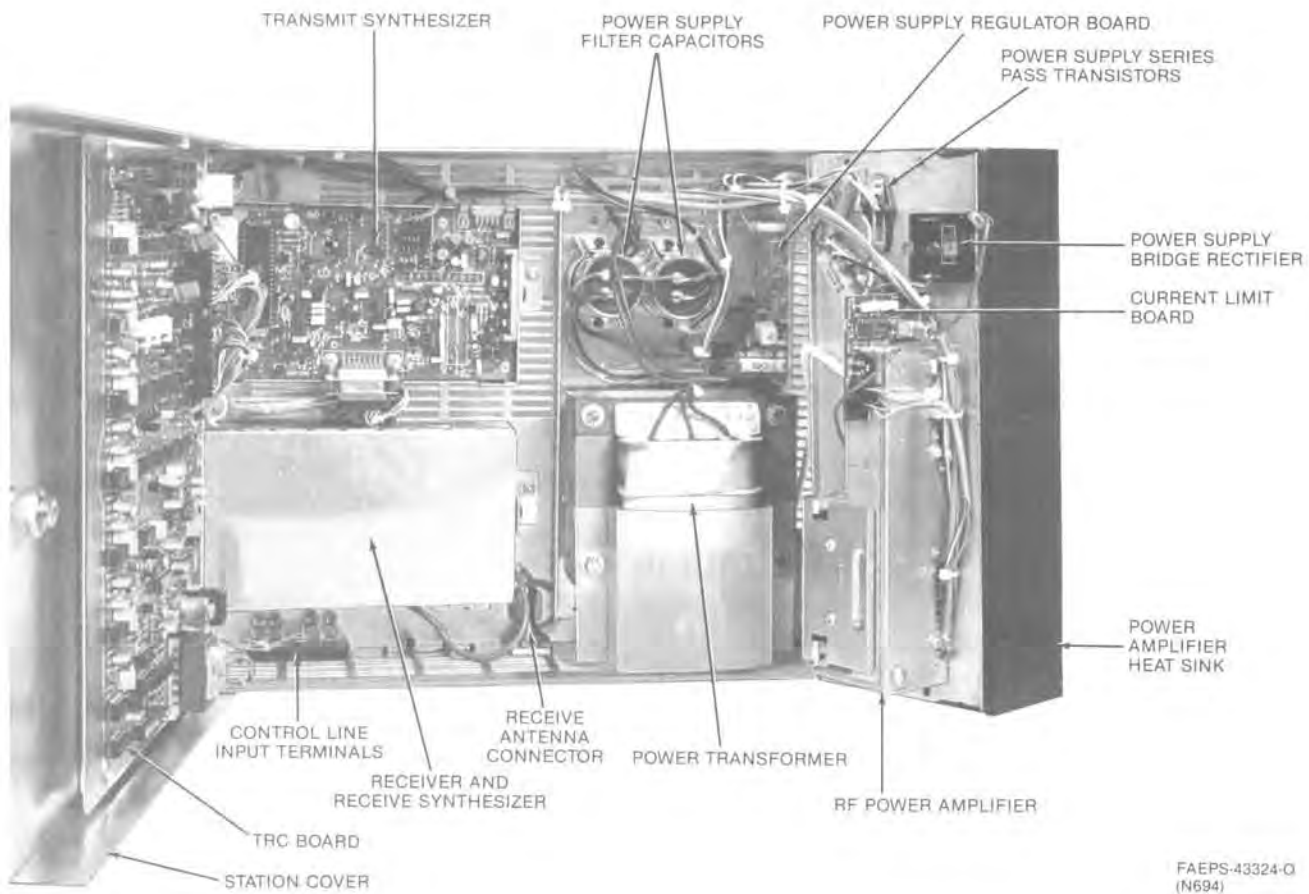

Figure 2. Major Station Components

4.1.2 Power Amplifier

Regardless of station model or rf power output, the power amplifier is mounted to a large heat sink at one end of the station. The output of the transmit synthesizer drives the power amplifier directly. The rf output of the transmitter is routed to an antenna connector separate from the receiver to minimize desense problems.

4.2 RECEIVER SECTION

4.2.1 Receive Synthesizer

The receive synthesizer is located on the rf board that is mounted in the same "H" frame chassis as the receiver. The output of the receive synthesizer is routed directly to the first mixer in the receiver to produce the proper signal input to the first if amplifier.

4.2.2 Receiver

The receiver is located in the "H" frame chassis along with the receive synthesizer. The receiver antenna input comes from a separate antenna connector. PL or DPL detection is performed by the receiver. Coded or carrier squelch control signals are routed to the TRC/RPTR control board. The audio output from the receiver is also routed to the TRC/RPTR control board, where it is then routed to the interface board for interconnection to the desk set and/or phone patch equipment. The interface board external cabling is used to carry transmit and received audio from the desk set to the station as well as the control signals from the desk set to select squelch mode (carrier squelch Vs PL or DPL squelch), repeater knockdown, PTT, as well as phone patch operating signals (if phone patch equipment is present).

4.3 CONTROL SECTION

The tone remote/RPTR control (TRC/RPTR) board contains the hardware necessary to operate the station. It allows for remote control of the station via wire line through connector Jaux and the interface board, which is hard-wired to the TRC/RPTR board. Standard *Motorola* TRC tones are decoded on the board and used to select the proper operating mode of the station. The TRC/RPTR board is capable of decoding six tones, which are:

- 2175 Hz - Guard tone
- 2050 Hz - PL Monitor
- 1950 Hz - Select or transmit on F1
- 1550 Hz - Repeater knockdown
- 1450 Hz - Repeater setup

The TRC/RPTR board is mounted inside the top cover of the station. There are two models of this board with usage dependent upon the station type (tone remote controlled repeater or rf controlled repeater). The circuit boards are identical except for the number of components contained on each. The fully populated board (Model GLN6768A) is used on all *Private-Line* or *Digital Private-Line* squelch, tone control models. The GLN6815A board is used in the rf controlled repeater stations

and contains no wireline circuitry or tone decoders. Therefore, it contains the fewest number of components. The TRC/RPTR board generally contains the guard tone decoders, function tone decoders, receiver audio circuits, and additional connectors to interface to various station options.

4.4 POWER SUPPLY SECTION

4.4.1 General

Two power supplies are used with the stations. Model GPN1009A for rf output power levels up to 10 watts, and Model GPN1010A for rf output power levels up to 25 watts. The two power supplies are identical except for the output current capability. When the 25-watt power supply is used, a current limiting board is used and mounted to the power amplifier housing. The same board is used, less the current limiting circuitry, on the 10-watt power amplifier for dc power distribution. The power supply transformer, regulator board, and filter capacitors are mounted on a common chassis, while the bridge rectifier and series pass regulator transistors are mounted on the power amplifier heat sink.

Both Model GPN1009A and GPN1010A power supplies are designed for automatic switchover to battery operation upon ac power failure. A battery trickle charging circuit is included to maintain the standby battery. The battery charging circuit is not designed to recharge a fully discharged battery, but only to maintain it and to supply a charge to make up for short ac power interruptions.

4.4.2 Theory Of Operation

The main difference between the 10-watt and 25-watt power supplies is the power transformer used, the fuse values, the number of filter capacitors and series pass transistors, and the type of rectifier circuit used. The regulator circuits are identical, as are the battery revert circuits. Therefore, only one regulator circuit and one battery revert circuit will be discussed in the following.

4.4.2.1 Power Input and Rectifier Circuit

The power supply uses series pass transistors to regulate the dc output voltage along with appropriate voltage sensing, voltage reference, and current limiting. Refer to the power supply schematic diagram 41-SP3760001 for details as required. The input voltage to transformer T1 can be 110V, 120V, 220V, 240V AC, 50/60 Hz and will operate properly with line variations of +10% and -20%. Multi-taps on T1 are adjusted for the proper input voltage. The secondary voltage of T1 is rectified and filtered differently as follows:

- Model GPN1009A use a full wave bridge rectifier with a single 10,000 microfarad filter capacitor.
- Model GPN1010A use a full wave, center tap rectifier with two 10,000 microfarad filter capacitors.

4.4.2.2 Regulator Circuit

Current source transistor, Q5, is a constant current source that supplies approximately eight milliamperes current to the base of Q6. Regulation is achieved by reference amplifier stage Q7 as it diverts current from the base of Q6 as the load on the supply changes, or as the input ac line voltage changes. The output of Q6 drives the base of Q4 which, in turn, drives the series pass transistors, Q1 and Q2.

The output of Q1 and Q2 is fed to a voltage divider consisting of R7, R8, R9, and D7. Resistor R8 sets the drive level of the reference amplifier Q7. Zener diode, D8, provides a fixed reference level to the emitter of Q7 that is compared to the voltage applied to its base through R8, which is a sample of the regulator output voltage. Any change in the sample voltage level at R8 changes the conduction of Q7. If the voltage at the base of Q8 goes lower, Q7 conducts less and Q6 is driven harder which, in turn, raises the output voltage of the regulator. R8 is adjusted to provide 13.6 - 14 volt output at low line (-10% nominal) and at maximum load (12 amperes, 25W units; 6 amperes, 10W units).

Current foldback and limiting is achieved by sensing the voltage drop across R2. The output of U1, a 12 volt regulator, is used to develop a voltage at the base emitter of Q3. When the voltage drop across R2 becomes large enough, Q3 conducts and begins to remove drive from Q6. This action removes drive from Q4 and, in turn, from Q1 and Q2. The result limits the current through series pass transistors Q1 and Q2.

4.4.2.3 Battery Revert Circuit

A voltage reference network consisting of D57, R66, D58, and D59 provides an independent stable voltage independent reference for all the comparators used in the battery revert circuit. Normally, the output voltage from the regulated supply operating on ac power is slightly higher than the standby battery voltage applied to TB1-A+ and TB1-GND which causes diode D55 to be reversed biased. The voltage at the anode of D58 is applied to the negative input of overvoltage detect comparator U52D, to the positive input of primary ac fail detect comparator U52C, and to the positive input of low battery detect comparator U52A.

During normal operation under ac power, the negative input of primary ac fail detect comparator U52C is more positive than the voltage applied at its positive input. This causes the output at U52C-8 to be low and Q52 to be turned off. When the ac power is lost, the voltage at U52-9 goes lower than the voltage at U52C-10 and its output, U52C-8, goes high. This action turns on Q5 which enables relay KS1 and applies battery power to the regulator circuits and disables Q51 providing an open collector, ON BATTERY output at P7-5.

If the battery voltage at U52A-2 drops below approximately 10.5 volts, the output of U52A will go high. This action turns on Q53 which provides a transistor switched LOW BATTERY output at P7-6.

The overvoltage detect circuit consisting of U52D and associated components monitors the dc output of the series pass regulators. If the output voltage of the series pass transistors goes higher than the reference input at U52D-13, the output of U52D goes high and causes an automatic switchover to battery operation by turning on Q52, which energizes relay KS1.

4.4.2.4 Battery Charging Circuit

The battery charging circuit is intended for use with sealed lead acid-gel cell batteries and is meant only for trickle charging or battery maintenance not for recharging of fully discharged batteries. The charging voltage is derived from U51, a 5-volt three-terminal self protected (overcurrent and thermal) regulator. The regulator is biased above ground to obtain a 13.6 volt dc output via R70, R71, U52B, and R72. Potentiometer, R70, sets the output of the regulator, U51, to 13.6 volts measured at the battery while the supply is operating from ac mains power.

The voltage at the arm of R70 is fed into unity gain operational amplifier, U52B, to raise its output at pin 7 to approximately 9 volts. This causes the output of U51 to be approximately 14 volts. Diode, D61, provides isolation for U51 R67 limits the current to approximately 300 milliamperes into a partially discharged battery. Once the battery is fully charged, the charging current will drop to between 10 and 25 milliamperes.

IMPORTANT

Trickle charging is intended to maintain the battery for long periods of time between power failures and is not intended for charging a fully discharged battery. If the battery is completely discharged, it must be removed and charged via a battery charger, as it could take as long as eight days to charge the battery using the built-in trickle charging circuit.

5. INSTALLATION

5.1 INTRODUCTION

Since a good installation is important to obtain the best possible performance of the station, carefully plan the installation before actual work is started. Location of the station in relation to power, control lines, the antenna, and convenience and access for servicing should be considered. Figure 3 is the cabinet dimensional detail. It shows the size of the cabinet for planning the space requirements. Read the entire procedure and the suggestions offered to help plan the installation. Make sure all equipment and facilities are available when the installation is begun. Attached diagram 9-SP3760001 is an exploded view of the station illustrating its mechanical parts, which are listed in the attached parts list 9PL-SP3760001.

5.2 VENTILATION

The station is designed for installation on a wall, and to operate without forced convection cooling. The cabinet has vents which allow normal convection cooling. It is essential that the vent openings be kept free of obstructions so that air flow will not be restricted. For proper cooling of the heatsink on the side of the unit, the fins must be in a vertical plane and free from obstructions both on top and bottom. To maintain proper ventilation, the unit must be mounted such that there is no obstruction or another unit within 100 mm of the sides and within 150 mm top and bottom.

NOTE

Sufficient clearance should be provided at the front of the unit to allow opening of the door, service access, and major component removal or replacement. Also, be sure that the air temperature around the unit in the rack does not exceed the recommended operating temperature for the unit.

5.3 STATION MOUNTING PROCEDURES

Step 1. Refer to Figure 3 for cabinet dimensional details.

Step 2. The station should be located on a solid vertical surface convenient to the power source and the rf transmission line, keeping in mind the ventilation requirements described previously.

NOTE

The transmission line should be kept as short as possible to minimize line losses. Refer to the attached Lightning Protection Recommendations Instruction section, 68P81111E17, for additional antenna, rf transmission line, and control line installation considerations.

Step 3. Mount the station at the selected location using appropriate fasteners to securely hold the station in place. The 2 watt station weighs 12 kg and the 25 watt station weighs 13 kg.

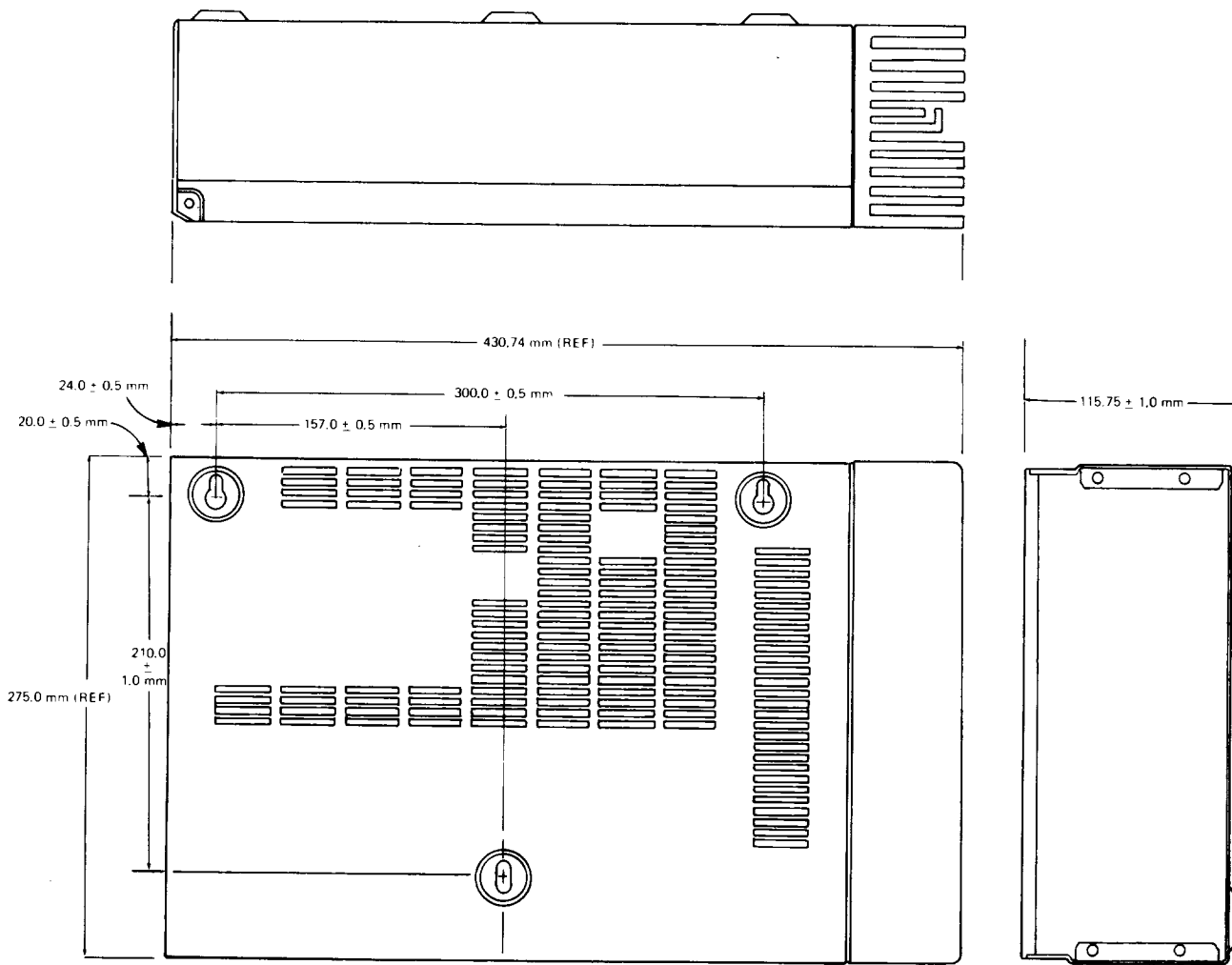

GDEPS-43322-O

Figure 3. Station Mounting Dimensional Detail (BOTTOM VIEW)

5.4 ANTENNA CONNECTIONS

The antennas and transmission lines are not part of the station. Therefore, antenna installation instructions are not included in this section. Follow the instructions shipped with the antenna for applicable information.

In its primary application, the station is used for communications with mobile radios. Thus, antennas having omni-directional characteristics are desirable. However, if the station is located at the outer perimeter of a communications area, or if it is to be used for communications with a fixed station, an antenna with specific directional characteristics may be more suitable. Local government agencies may also dictate the type of antenna to be used.

All coaxial antenna cables connect to UHF coaxial connectors located on the bottom of the station. Refer to Figure 4. Stations without an external duplexer require two antennas; one for transmit and one for receive. Stations with an external duplexer (customer supplied) require only one antenna. Cabling required to connect the station to a Motorola Model TDN7407A External Duplexer is available via Option L658AA-SP.

NOTE

If a customer supplied external duplexer is used, connect: the antenna port of the duplexer to the antenna; the receive port of the duplexer to the station RX connector; and, the transmit port of the duplexer to the station TX connector (see Figure 4).

5.5 POWER AND GROUND CONNECTIONS

5.5.1 General

All stations should have a separate ac power circuit of the proper current and voltage for station operation. The power lines should be installed in accordance with local electrical codes. A substantial earth ground must be provided as close to, and in as straight a line as possible, with the ground terminal provided on the station. Do NOT consider an electrical outlet box as a substantial earth ground. Refer to the attached Lightning Protection Recommendation Instruction section, 68P81111E17, for additional grounding recommendations.

WARNING

Even if a three wire grounded ac power source is available, the radio equipment must be separately grounded to prevent electrical shock hazards and provide lightning protection.

The ac power line may be installed prior to installation of the station and terminated near the location chosen for the station.

5.5.2 AC Input Power

Step 1. Install the station as described in the Station Mounting Procedures paragraph.

Step 2. Connect the female plug of the ac line cord to the ac input power connector on the bottom of the station. Refer to Figure 4.

Step 3. Connect the ground terminal on the station to a substantial earth ground located as close as possible, and in as straight a line as possible, to the station ground terminal.

NOTE

A power ON-OFF switch is not provided on the station. Therefore, the station is immediately operational when its power cord is plugged into a live ac outlet.

Step 4. Make certain the ac power source is of the proper current and voltage for the station. Then connect the male plug of the ac line cord to the ac power source.

5.5.3 DC Input Power

Connection of dc input power to the station is customer supplied. The source of dc power should be connected to the terminal block on the bottom of the station. See Figure 4.

CAUTION

Be sure to observe proper polarity when making the dc power connections, to prevent damage to the station.

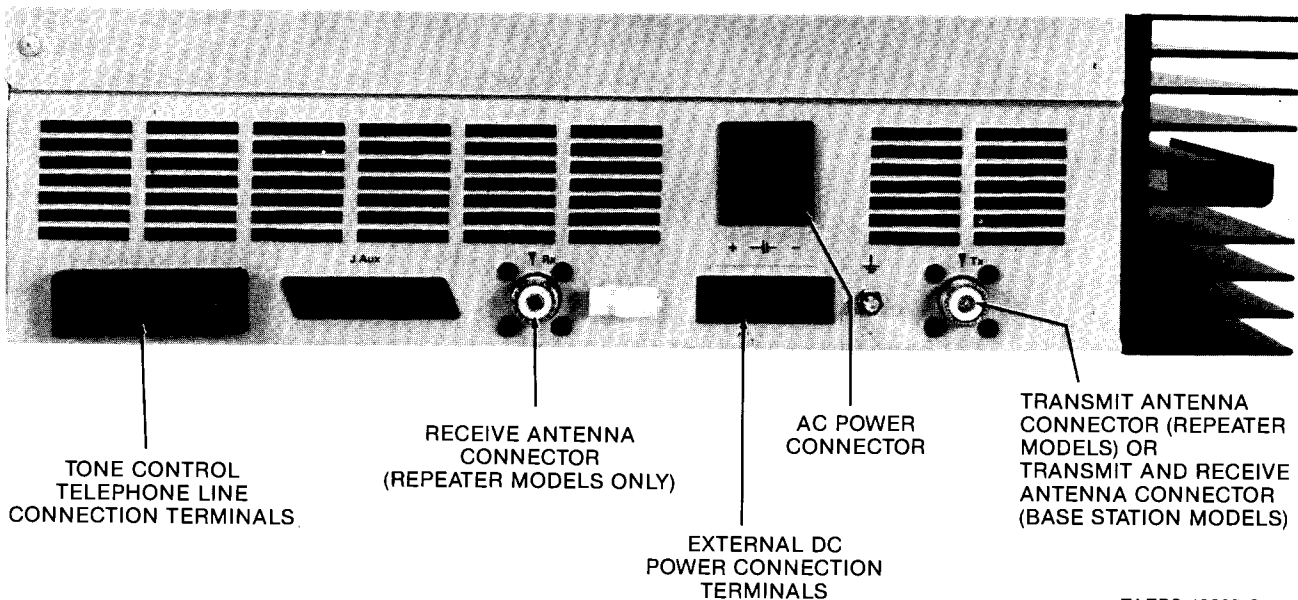

FAEPS-43325-0
(1698)

Figure 4. External Connection Detail

5.6 CONTROL LINE CONNECTIONS AND LEVEL SETTINGS

5.6.1 GENERAL

The station uses simplex control. This means that a tone remote control console, or a local control desk set and/or phone patch equipment, can send audio to the station for transmission, or receive audio from the station, but not both at the same time. The tone remote control console is connected via a wire line pair to the LINE 1 terminals of TB1. The local control desk set and/or phone patch equipment connected at Jaux.

5.6.2 Wire Line Specifications

The wire line pair must meet the following specifications for acceptable radio communications. Verify the characteristics of leased telephone lines with the company providing the service before installation.

Frequency response: 500 to 2500 Hz
Frequency translation error: ± 5 Hz
Impedance: 600-ohm or 900-ohm balanced line
Maximum line loss: 20 dB

5.6.3 Control Line Level Adjustment

5.6.3.1 General Information

Most telephone companies limit the maximum signal amplitude which they will allow on their lines. Check the telephone company for the maximum level to be used on your lines. Adjust the audio levels to the maximum permissible level which will give the best signal-to-noise ratio. For lines not subject to telephone company restrictions, set the line level to +11 dBm.

5.6.3.2 Line Level Adjustments

- Tone Control Line Levels

The control tone levels for remote controlled functions are adjusted at the remote control console. No additional adjustments are required at the station.

- Transmit Audio Line Adjustments

The preferred method for adjusting transmit audio line levels is to utilize the remote control console as a signal source. This is necessitated by the variation in wireline attenuation. The transmit audio line level should be adjusted per the following procedure.

Step 1. Send a 1 kHz tone from the console at the maximum line level allowed by the telephone company.

Step 2. Adjust potentiometer R1002 for 360 mV rms at test point 3 on the TRC/RPTR control board.

- Receive Audio Line Level Adjustment

Step 1. Connect an rf signal generator to the station RX antenna port. Refer to Figure 4.

Step 2. Connect an HP3552 (or equivalent) transmission test set across the console wireline port and select the REC TERM function with 600 ohms impedance selected. If a transmission test set is not available, connect a 600 ohm $\pm 1\%$ resistor across the wireline and use a high impedance ac voltmeter to make the measurements.

NOTE

To PL disable the station receiver, if required, place the PL DISABLE switch on the TRC/RPTR control board to the ON position. A yellow LED on the board should light indicating PL disable mode.

Step 3. Apply a 1000 mV rms on-channel frequency signal.

Step 4. Modulate the on-channel frequency signal with a 1 kHz sine wave at 5 kHz full scale deviation.

Step 5. Adjust Potentiometer R831 on the TRC/RPTR control board for the maximum wireline output level allowed by the telephone company (or +11 dBm).

5.7 JUMPERING INFORMATION

The following paragraphs provide tabular jumper information required to determine desired system operation. Refer to these tables upon installation for proper station jumper configuration.

5.7.1 Tone Remote/RPTR Control Board Jumpers

Table 1. Tone Remote/RPTR Control Board Jumpers

REF. SYMBOL	GLN6768A TRC/RPTR	GLN6815A RPTR
JU1	IN	OUT
JU2	OUT	OUT
JU3	IN	OUT
JU4	OUT	OUT
JU5	IN	OUT
JU6	IN	OUT
JU7	IN	OUT
JU8	IN	OUT
JU9	IN	OUT
JU10	IN	OUT
JU11	OUT	OUT

JU12

Variable repeater Drop-Out-Delay is determined by use of JU12 and three resistors. The factory preset value is 2 seconds. If a different value is desired, then Field Service personnel must configure each Station to customer requirements per the following table.

DROP-OUT-DELAY	JU12	R922	R923	R924
0 Sec	IN	IN	IN	IN
1 Sec	OUT	IN	IN	IN
2 Sec	OUT	OUT	OUT	IN
3 Sec	OUT	IN	IN	OUT
4 Sec	OUT	OUT	IN	OUT
7 Sec	OUT	IN	OUT	OUT

JU13	UNDEFINED	UNDEFINED
JU14	OUT	OUT
JU15	IN	IN
JU16	OUT	OUT

Table 1. Tone Remote/RPTR Control Board Jumpers, cont'd.

REF. SYMBOL	GLN6768A TRC/RPTR	GLN6815A RPTR
JU17	OUT	OUT
JU18	OUT	OUT
JU19	IN	OUT (Note 1)
JU20	IN	OUT
JU21	IN	OUT
JU22	IN (Note 2)	IN
JU23	OUT	OUT
JU24	IN	IN
JU25	OUT	OUT
JU26	IN	IN
JU27	OUT	OUT
JU28	OUT (Note 3)	OUT
JU29	IN	IN
JU30	OUT	OUT
JU31	IN	OUT
JU32	OUT	OUT
JU33	OUT	OUT
CR810	IN	OUT
R832	OUT	OUT

NOTES:

1. IN for Option L141
2. OUT for Option L143
3. IN for Option L143

5.7.2

Command Board Jumpers

The station has two separate command boards installed.

- The RX chassis has a Model GLN6810A Receive Command board in a Q2903A or Q2931A Station. Or, a Model GLN6810A-SP500 Receive Command Board in a Q2904A or Q2932A Station.
- The TX chassis has a Model GLN6811A Transmit Command board in a Q2903A or Q2931A Station. Or, a Model GLN6811A-SP500 Transmit Command Board in a Q2904A or Q2932A Station.

Table 2. Receive Command Board Jumpers.

REF. SYMBOL	INSTALLATION	DESCRIPTION
JU551	OUT	Deemphasized Audio
JU552	IN	Deemphasized Audio
JU701	OUT	Always
JU702	IN	Always
JU703	OUT	Always
JU704	IN	Always
JU705	OUT	Normally
JU706	OUT	Normally
JU707	IN	Always
JU802	IN	Always
The following jumpers, labeled JQxxx, are installed between collector and emitter holes of removed transistors.		
JQ404	IN	Always
JQ551	IN	Always
JQ707	IN	Always
JQ712	IN	Always

Table 3. Transmit Command Board Jumpers

REF. SYMBOL	INSTALLATION	DESCRIPTION
JU601	OUT	Preemphasized Audio
JU602	IN	Preemphasized Audio
JU701	OUT	Always
JU702	IN	Always
JU703	OUT	Always
JU704	IN	Always
JU705	OUT	Normally
JU706	OUT	Normally
JU707	IN	Always
The following jumpers, labeled JQxxx, are installed between collector and emitter holes of removed transistors		
JQ404	IN	Always
JQ707	IN	Always
JQ712	IN	Always
JQ720	IN	Always

6. MAINTENANCE

6.1 GENERAL

This section details procedures required in the overall maintenance of the rf and control portions of the station.

IMPORTANT

The FCC requires that the Grantee of a license has the responsibility of assuring that all equipment operated under that license conforms to the specifications of the license. Motorola recommends that adjustments to this equipment be made **ONLY** by a certified technician.

The first part of this section consists of the procedures required to locally operate the station during servicing. This allows service personnel to operate all functions of the station without an operator present at the control site. The second part contains the remote control alignment procedure for transmit and receive audio, guard tone filters, and phase lock loop decoders. These adjustments have all been made in the factory, but may need to be performed again in the field if any repairs are made. The third section contains the alignment procedures for the rf section of the radio.

6.2 LOCAL SERVICE OPERATION

The cover on the station housing must be opened in order to access the local control switches located on the tone remote/RPTR (TRC/RPTR) control board. Additionally, the interface board may have to be moved to access several of the adjustments located on the TRC/RPTR board. Refer to Figure 5 for local control switch and adjustment locations.

WARNING

The transmitter can be keyed remotely. To prevent unexpected transmitter keying while servicing the station, be sure the LINE DISABLE switch and REPEATER DISABLE switch on the TRC/RPTR board are actuated.

The optional service handset plugs into connector J3 on the TRC/RPTR board to enable either local transmit with modulation or provide an intercom between the serviceman and the remote console operator (refer to the intercom switch operation paragraph). The optional service speaker can be plugged into connector P2 in order to listen to received audio. Reprogramming of the station is accomplished by connecting the 6-pin modular connector on the field programmer interface cable to connector J8 (receiver) or J9 (transmitter) on the TRC/RPTR board.

There are six switches on the TRC/RPTR board that permit local operation. Refer to Figure 5 for switch locations. Table 4 lists each switch along with a functional description of its operation.

Table 4. TRC/RPTR Board Local Control Switch Functions

INSTALLED SWITCH	POSITION	FUNCTIONAL DESCRIPTION
Repeater Disable - SW1	OFF	Normal station operation.
	ON	Disables station operation.
Line Disable - SW2	OFF	Normal station operation.
	ON	Disables control from the remote console.
Local PTT - SW3		This is a momentary switch. When it is depressed, the station will transmit without modulation. The unit stops transmitting when the switch is no longer depressed to prevent the serviceman from leaving the station in a transmit mode. Plug the optional service handset into modular connector J3, on the TRC/RPTR board to modulate the transmitter.
F1/F2 Select - SW4 (GLN6768A only)	F1	Not enabled
	F2	Not enabled
PL Disable - SW5 (GLN6768A only)	OFF	Receiver PL/DPL circuits are enabled.
	ON	Receiver PL/DPL circuits are disabled.
Intercom - SW6	INTERCOM	Selects Intercom mode. This mode permits the serviceman to communicate with the remote console operator while servicing the station. The Intercom mode inhibits transmitter key up when the handset PTT button is depressed. Instead, the serviceman's audio is routed down the wire line to the remote console.
	INTERCOM/PTT	Normal station operation.

6.3 RECOMMENDED SERVICE EQUIPMENT

R2001 Communications System Analyzer, R2200 Service Monitor, or equivalent
R1037 Digital Multimeter, or R1024 Digital Multimeter, or equivalent
HP8903 Audio Analyzer, or equivalent
HP3552 Transmission Test Set, or equivalent

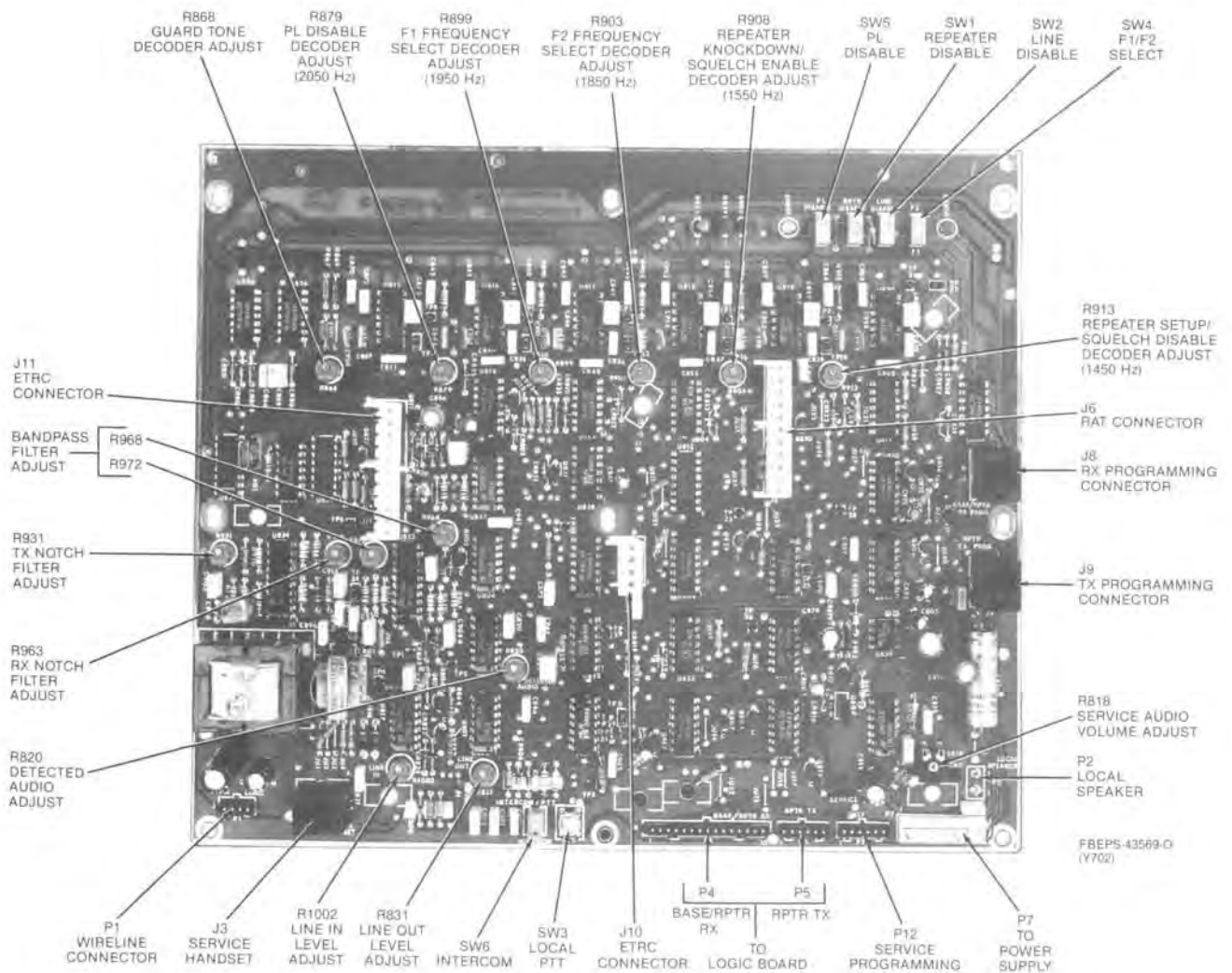

Figure 5. Tone Remote/RPTR Control Board Adjustment Locations

6.4 TONE REMOTE/RPTR CONTROL BOARD ALIGNMENT

The following paragraphs contain the TRC/RPTR control board alignment procedures for transmit and receive audio, guard tone filters, and phase lock loop decoders. These adjustments have all been made in the factory, but may need to be performed again in the field if any repairs are made. All adjustments are made on and all test points are located on the TRC/RPTR board. Refer to Figure 5 for adjustment and test point locations.

6.4.1 Detected Audio Level Adjust

Step 1. Set the Repeater Disable switch to the ON position. Connect a 4 ohm load across the local speaker connector P2. (If the station is controlled from a remote location, also connect a 600 ohm load across the LINE 1 terminals on TB1). Apply an on-channel signal at 1 mV rms with 1 KHz modulation, at 3 KHz deviation, to the RX antenna connector.

Step 2. If the station has PL/DPL squelch, set the PL Disable switch to the ON position.

Step 3. Adjust Detected Audio control R820 for 160 mV rms at TP1. (If the station is controlled from a remote location, then adjust Line Out control R831 for +11 dBm).

Step 4. Adjust Service Audio control R818 for 1.4 V rms across the 4 ohm load. Measure the distortion at the Line (less than or equal to 3%) and at the local speaker connector (less than or equal to 5%).

6.4.2 Receiver Notch Filter Adjustment

Step 1. Set the Repeater Disable switch to the ON position. Connect a 4 ohm load across the local speaker connector P2. (If the station is controlled from a remote location, also connect a 600 ohm load across the LINE 1 terminals on TB1). Apply an on-channel signal at 1 mV rms with 1 KHz modulation, at 3 KHz deviation, to the RX antenna connector.

Step 2. If the station has PL/DPL squelch, set the PL Disable switch to the ON position.

Step 3. Adjust Detected Audio control R820 for 160 mV rms at TP1. Then, adjust Line Out control R831 for 0 dBm.

Step 4. Change the modulating frequency to the guard tone frequency (2175 Hz), at 3 kHz deviation.

Step 5. Adjust RX Notch Filter control R963 for a Line 1 level at least 35 dB below the 0 dBm reference.

NOTE

The notch filter depth should be at least less than or equal to 30 dB below the 0 dBm reference. However, if the notch depth is less than 30 dB below the 0 dB reference, the notch should be re-aligned.

Step 6. If the station is controlled from a remote location, then re-adjust Line Out control R831 for +11 dBm.

6.4.3 Transmitter Notch Filter Adjustment

Step 1. Apply a 0 dBm, 1 KHz tone to Line 1. Adjust Line In control R1002 for 360 mV rms at TP3 on the TRC/RPTR board.

Step 2. Short Test Point 0 to A+. Measure the level at P5-3. Use this level to set up a 0 dB reference.

Step 3. Change the modulating frequency to the guard tone frequency (2175 Hz). Maintain the 0 dB reference level.

Step 4. Adjust TX Notch Filter control R931 for a level at least 35 dB below the 0 dB reference at P5-3.

NOTE

The notch filter depth should be at least less than or equal to 30 dB below the 0 dBm reference. However, if the notch depth is less than 30 dB below the 0 dB reference, the notch should be re-aligned.

6.4.4 Transmitter Bandpass Filter Adjustment

Step 1. Perform the Transmit Notch Filter Adjustment. Maintain the guard tone frequency (2175 Hz) at Line 1

Step 2. Monitor the rms voltage at TP40, and adjust Bandpass Filter control R968 for the PEAK indication.

Step 3. Monitor the rms voltage at TP5, and adjust Bandpass Filter control R972 for the PEAK indication.

Step 4. Repeat Steps 2 and 3 ONCE. The final PEAK levels should be between 1 and 1.6 V rms.

6.4.5 Guard Tone Decoder Adjustment

Step 1. Monitor the frequency at TP8 while shorting the two pins at TP7 together.

Step 2. Adjust Guard Tone Decoder control R868 for a frequency of 2175 ± 1 Hz at TP8.

6.4.6 PL Disable Decoder Adjustment

Step 1. Monitor the frequency at TP11 while shorting the two pins at TP10 together.

Step 2. Adjust PL Disable Decoder control R879 for a frequency of 2050 ± 2 Hz at TP11.

6.4.7 F1 Frequency Select Decoder Adjustment

Step 1. Monitor the frequency at TP14 while shorting the two pins at TP13 together.

Step 2. Adjust F1 Frequency Select Decoder R899 for a frequency of 1950 ± 2 Hz at TP14.

6.4.8 Repeater Knockdown Decoder Adjustment

Step 1. Monitor the frequency at TP20 while shorting the two pins at TP19 together.

Step 2. Adjust Repeater Knockdown control R908 for a frequency of 1550 ± 2 Hz at TP20.

6.4.9 Repeater Setup/Squelch Disable Decoder Adjustment

Step 1. Monitor the frequency at TP23 while shorting the two pins at TP22 together.

Step 2. Adjust Repeater Setup control R913 for a frequency of 1450 ± 2 Hz at TP23.

6.5 RF ADJUSTMENTS

Refer to Figures 6 and 7 for adjustment locations.

6.5.1 Preliminary

The rf adjustment procedures contained in the following paragraphs require that the following conditions be met prior to alignment:

- All references to clockwise (CW) or counter-clockwise (CCW) adjustment of controls assume that adjustments are made from the component side of the circuit board.
- Prior to performing adjustments the radio must be completely assembled except for the synthesizer compartment top cover and chassis cover.

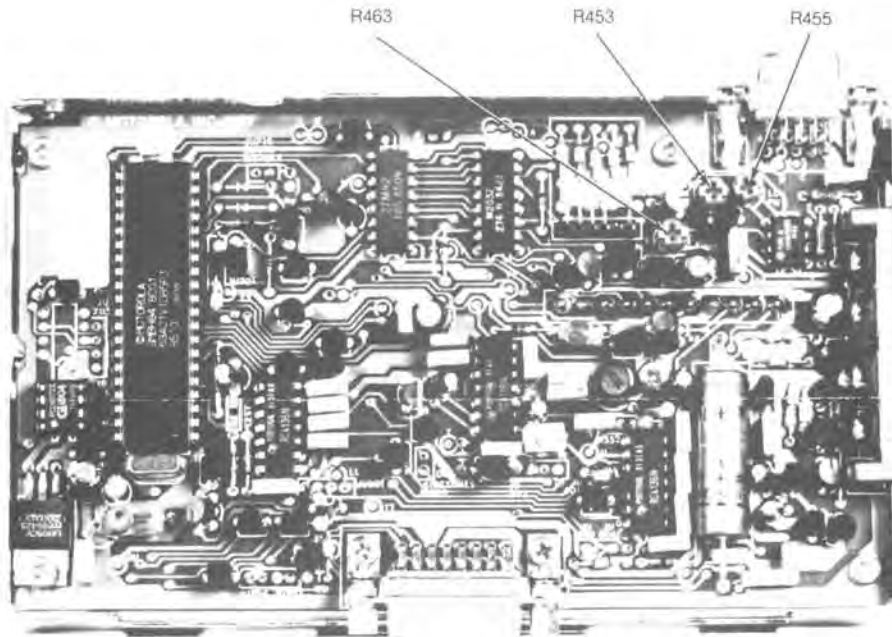

GBW-2101-0

Figure 6. Command Board Adjustment Locations

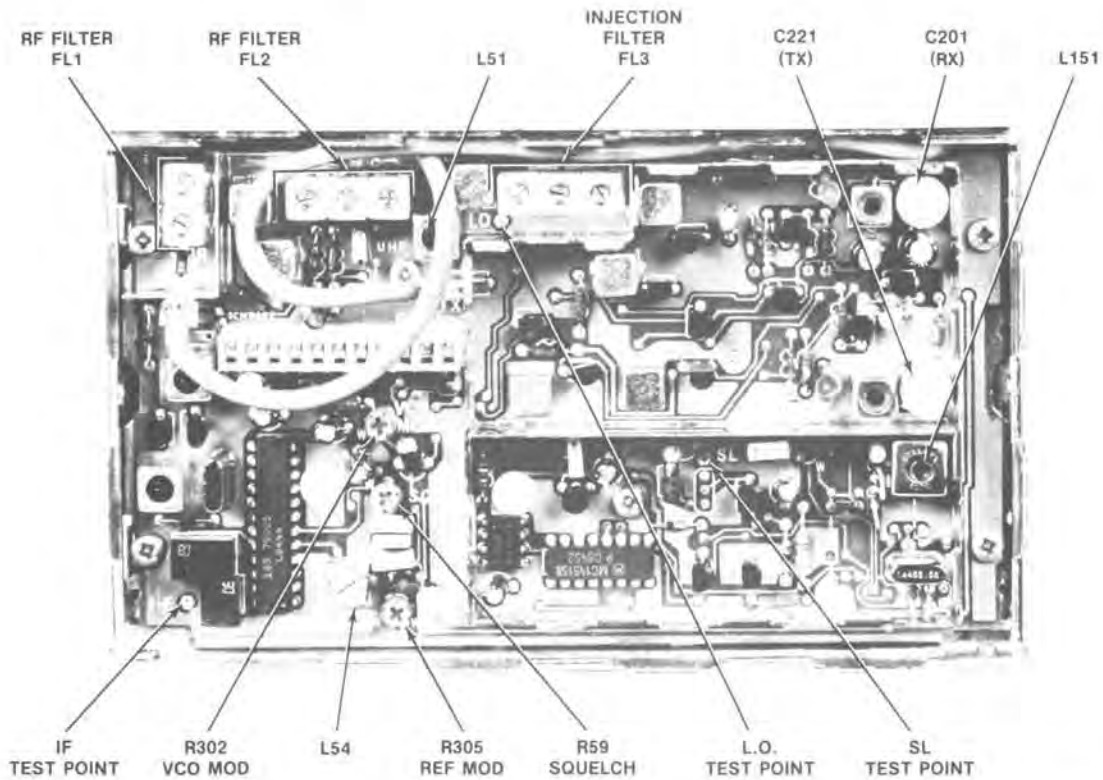

GBW-2299-0

Figure 7. UHF RF Board Adjustment Locations

In these stations, the transmitter and receiver are separate chassis. Each has a separate antenna connector, on the bottom of the station, respectively labeled TX and RX. Therefore, whenever a transmitter adjustment is required, it should be performed on the transmitter chassis. Whenever a receiver adjustment is required, it should be performed on the receiver chassis.

To line disable the station set Line Disable switch SW2 to the ON position. To PL disable the station set PL Disable switch SW5 to the ON position. A yellow LED on the board will light, indicating the PL disable mode. To key the station, depress the momentary Local PTT switch.

6.5.2 Transmitter Adjustment

IMPORTANT

On 25 W Stations, adjust Current Limit control R477, on the PA current limiter board, fully CW before beginning transmitter adjustment.

6.5.2.1 VCO Adjustment

Step 1. Connect a dc voltmeter from the steering line test point (SL) to ground. Meter impedance should be 11 megohms or greater.

Step 2. Key station, and adjust TX VCO frequency control C221 for a reading of 6 V dc. Dekey station.

6.5.2.2 Output Power Adjustment

NOTE

Key station only during actual adjustments or measurements.

Step 1. Preset the controls on the transmit command board as follows:

REFERENCE SYMBOL	FUNCTION	SETTING
R453	High Power Set	Fully CCW
R455	Low Power Set	Fully CCW
R463	Voltage Limit	Fully CW

Step 2. Connect the transmitter antenna connector to an accurate rf power meter that provides a 50 ohm load.

Step 3. Adjust Output Voltage Set control R8, on the Power Supply Regulator board, for an A+ equal to 13.2 ± 0.1 V dc.

Step 4. Key station, and adjust High Power Set control R453 for 2 W (on 2-10 W models) or 25 W (on 25 W models). Dekey station.

Step 5. Key the station and observe the dc voltage at P6-4 or at test point CV on the command board. Record the voltage. If the voltage is greater than 10 V dc, go to Step 8. If not, continue with Step 6. Dekey station.

Step 6. Turn Voltage Limit control R463 fully CCW. Turn High Power Set control R453 fully CW.

Step 7. Key station. Adjust Voltage Limit control R463 for a dc voltage which is 2.0 volts higher than the voltage level recorded in Step 5, as measured at P6-4, or at test point CV.

Step 8. Turn High Power Set control R453 fully CCW.

Step 9. Key station and observe the dc voltage at TP476, on the PA current limit board. Adjust Current Limit control R477 for $7.5 \pm .05$ V. Dekey Station.

Step 10. Key station and adjust High Power Set control R453 for 10.7 Watts (on 2-10 W models), or 26.8 W (on 25 W models). Dekey station.

Step 11. Verify that the station will produce at least 2.0 W (or 25.0 W) for its appropriate model.

6.5.2.3 Reference Oscillator Adjustment

Step 1. Connect the TX antenna connector to an accurate frequency counter through a suitable attenuator.

Step 2. Key station and adjust 2 PPM Frequency control R163 (on TX RF board) for the exact transmit frequency (± 100 Hz). Dekey station.

6.5.2.4 Deviation Adjustment

Step 1. Connect the transmitter antenna connector to a modulation analyzer or test receiver through a suitable attenuator.

Step 2. Connect an audio oscillator to Service Handset connector J3 (+ to J3-4 and - to J3-5). Monitor the voltage at P12-3 on the TRC/RPTR board. Set the oscillator frequency to 1 KHz. Adjust its output for a level of 800 mV rms at P12-3.

Step 3. Preset VCO MOD R302, and Reference MOD R305 control fully CCW.

Step 4. Set the modulation analyzer operational controls to: FM (non de-emphasized) and CCITT Filter OFF.

Step 5. Key station and adjust VCO MOD control R302 for a ± 4.6 kHz deviation level.

NOTE

If the + and - deviation readings differ, observe only the higher reading.

Step 6. Change the oscillator frequency to 200 Hz. Maintain the output level of 800 mV rms at P12-3.

Step 7. Key station and observe the waveform on an oscilloscope which is dc coupled to the demodulated output of the modulation analyzer or a test receiver. The test receiver should be non-deemphasized. Adjust Reference MOD R305 control for the flattest square wave response with minimum tilt. Do not defeat PL/DPL (if present) when performing this adjustment.

Step 8. Return the audio oscillator to 1 KHz and 800 mV rms, and repeat Step 5.

6.5.2.5 2-10 Watt RF Power Output Field Adjustment Procedure

IMPORTANT

The rf power output of 2-10 W Models is continuously variable from 2 W to 10 W. All of these models are shipped set for a 2 W output.

Step 1. Disconnect Antenna. Connect an rf wattmeter with a 25 W load (minimum) to the transmit antenna connector (Tx).

Step 2. Unlock and open station cabinet.

Step 3. Locate and identify the PTT pushbutton switch (SW3) on the TRC/RPTR Control board. Refer to Figure 5.

Step 4. Locate and identify the high power set control (R453) on the Transmit Command board. Refer to Figure 6.

Step 5. Energize station. Monitor rf power output.

Step 6. Depress SW3, and adjust R453 for customer licensed rf power output.

Step 7. Release SW3. De-energize station. Disconnect wattmeter. Close and lock station cabinet. Reconnect antenna.

6.5.3 RECEIVER ADJUSTMENTS

6.5.3.1 VCO Adjustment

NOTE

Adjust the transmitter VCO and reference oscillator (Paragraph 6.5) before aligning the receiver.

Step 1. Connect a dc voltmeter from the steering line test point (SL) to ground. The meter impedance should be 11 megohms or greater.

Step 2. Adjust RX VCO control C201 for a reading of 6.0 V dc.

6.5.3.2 RF and I-F Alignment

Step 1. Connect a 4 ohm resistive load across Local Speaker connector P2 on the TRC/RPTR board. Receiver audio output is monitored across this load.

Step 2. Preset the slugs or screws of the front end coils or helicals to 2 mm above the top of the can.

Step 3. Connect a dc voltmeter from the local oscillator test point LO to ground. Starting with the center screw, peak the three cells of injection filter helical FL3 for a maximum dc voltage, typically between 2.5 and 3.5 V dc. Repeat until no further increase is obtained.

Step 4. PL disable the receiver (PL models only) by setting PL Disable switch SW805, on the TRC/RPTR board, to the ON position. Connect an rf signal generator to the RX antenna connector. Adjust the generator to produce an unmodulated on-carrier signal strong enough to quiet the receiver.

Step 5. Connect an ac voltmeter having at least a 1 MHz bandwidth from the I-F test point to ground. Adjust the rf generator level until an indication of in the range of 10 to 30 mV rms is obtained on the voltmeter. Adjust the following coils, in the order listed, for a maximum indication on the voltmeter, while reducing the generator output level as required to keep the voltmeter indication in the range of 10 to 50 mV rms. Repeat until no further increase occurs.

- FL1: Begin with the screw closest to J1;
- FL2: Begin with the screw closest to FL1; and then,
- L51.

Step 6. Using the same signal input as given in Step 5, adjust FL3 for a maximum indication on the voltmeter.

Step 7. After completing the alignment of FL1, FL2, and FL3 their adjusting screws should be secured with paint to prevent detuning.

Step 8. Set the rf generator rf level to 1 mV. Modulate with a 1 KHz tone at 30kHz deviation. Adjust Volume Control R818 on the TRC/RPTR for about 1 V rms audio level across the 4-ohm load. Slowly peak the quad coil L54 for a maximum audio output level.

Step 9. PL enable the station (if required) by setting the PL Disable switch to the OFF position.

6.5.3.3 Squelch Adjustment

Step 1. PL disable the receiver (PL/DPL models only) by setting PL Disable switch SW805, on the TRC/RPTR board, to the ON position. Preset Squelch control R59 fully CCW. Connect a 4 ohm resistive load across Local Speaker connector P2 on the TRC/RPTR board. Receiver audio output is monitored across this

load. Connect an rf signal generator to the RX antenna connector. Adjust the generator to produce an on-carrier rf signal at a level of 1 mV rms. Modulate it with a 1 kHz tone at 3 kHz deviation.

Step 2. Adjust Volume control R818 on the TRC/RPTR board for 1.4 V rms audio level across the 4 ohm load.

Step 3. Reduce the rf signal level until 17 dB SINAD is obtained.

Step 4. Turn Squelch control R59 slowly CW until the tone across the 4 ohm load is muted. Then, very slowly, turn R59 CCW until the tone is again present.

Step 5. Reduce the rf level to zero. Slowly increase the rf level until the tone is present across the 4 ohm load. Verify that the SINAD at this rf level is between 16 and 18 dB.

Step 6. PL enable the station (if required) by setting the PL Disable switch to the OFF position.

6.6 DISASSEMBLY AND SERVICE ACCESS

The attached station exploded view diagram 9-SP3760001 illustrates how the station is disassembled and identifies all mechanical parts.

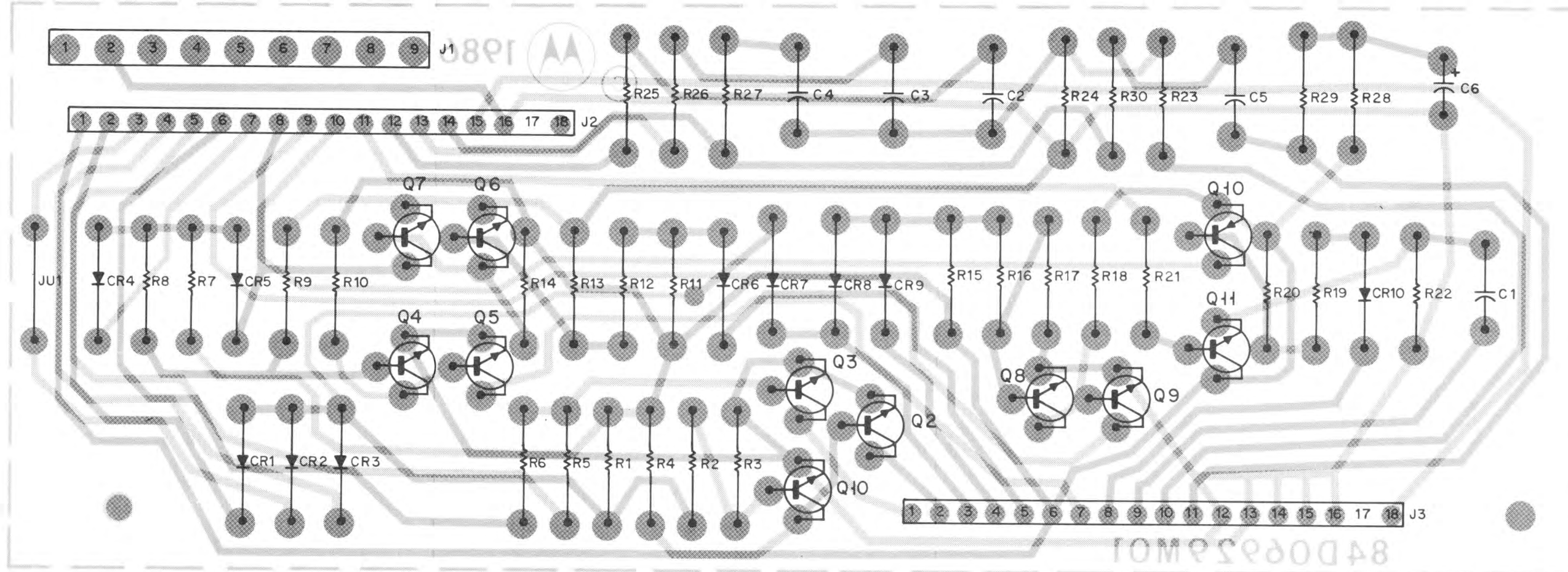

SHOWN FROM COMPONENT SIDE

2- SP3760001-1
(SHEET 1 OF 2)

PHONE PATCH OR DESK SET

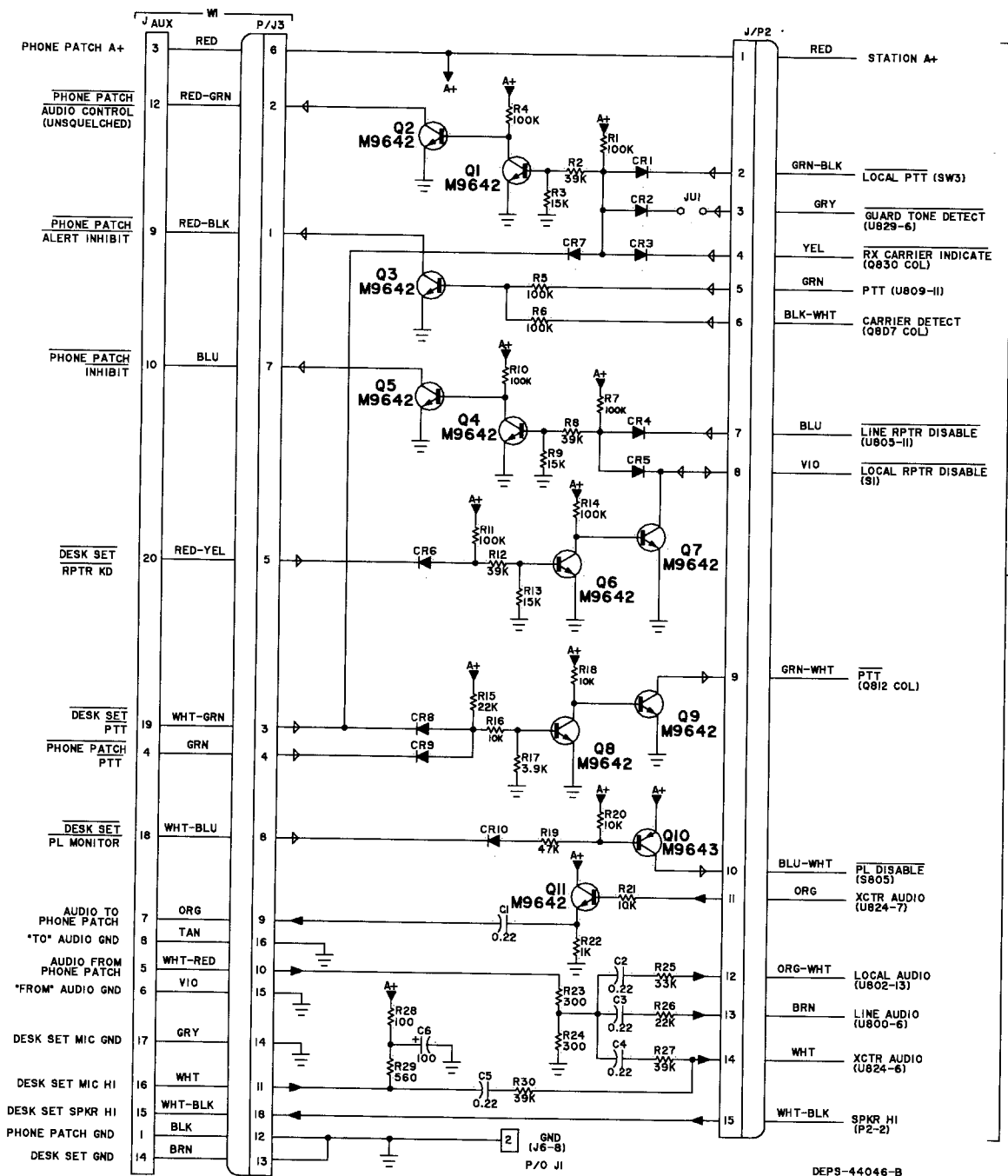

TONE REMOTE/REPEATER CONTROL BOARD

DEPS-44046-B

PARTS LIST

REF SYMBOL	MOTOROLA PART NO.	DESCRIPTION
C1 thru 5	0811023A29	<u>CAPACITOR, fixed:</u> polyest 0.22uf ±5% 50V
C6	2311019A46	Alu 100 ±20% 25V
CR1 thru 10	4883654H01	<u>DIODE: (SEE NOTE)</u> silicon
J1	2880261H02	<u>CONNECTOR, plug:</u> male, 9 contact
J2, 3	0907079H02	female, 18 contact
JU1	0611009D23	<u>JUMPER, resistive:</u> 0 ohm
Q1 thru 9	4800869642	<u>TRANSISTOR: (SEE NOTE)</u> NPN; type M9642
Q10	4800869643	PNP; type M9643
Q11	4800869642	NPN; type M9642
R1	0611009C97	<u>RESISTOR, fixed: ±5%; 1/4W</u> unless otherwise stated 100k
R2	0611009C87	39k
R3	0611009C77	15k
R4 thru 7	0611009C97	100k
R8	0611009C87	39k
R9	0611009C77	15k
R10, 11	0611009C97	100k
R12	0611009C87	39k
R13	0611009C77	15k
R14	0611009C97	100k
R15	0611009C81	22k
R16	0611009C73	10k
R17	0611009C63	3900
R18	0611009C73	10k
R19	0611009C89	47k
R20, 21	0611009C73	10k
R22	0611009C49	1000
R23, 24	0611009C36	300
R25	0611009C85	33k
R26	0611009C81	22k
R27	0611009C87	39k
R28	0611009C25	100
R29	0611009C43	560
R30	0611009C87	39k
	4382980N07	<u>NON-REFERENCE ITEM:</u> STANDOFF, board support; 2 used

NOTE: For optimum performance, diodes, transistors, and integrated circuits must be ordered by Motorola part numbers.

QRN4314A Interface Board Parts List
Motorola No. 2PL-SP3760001-2
3/30/87

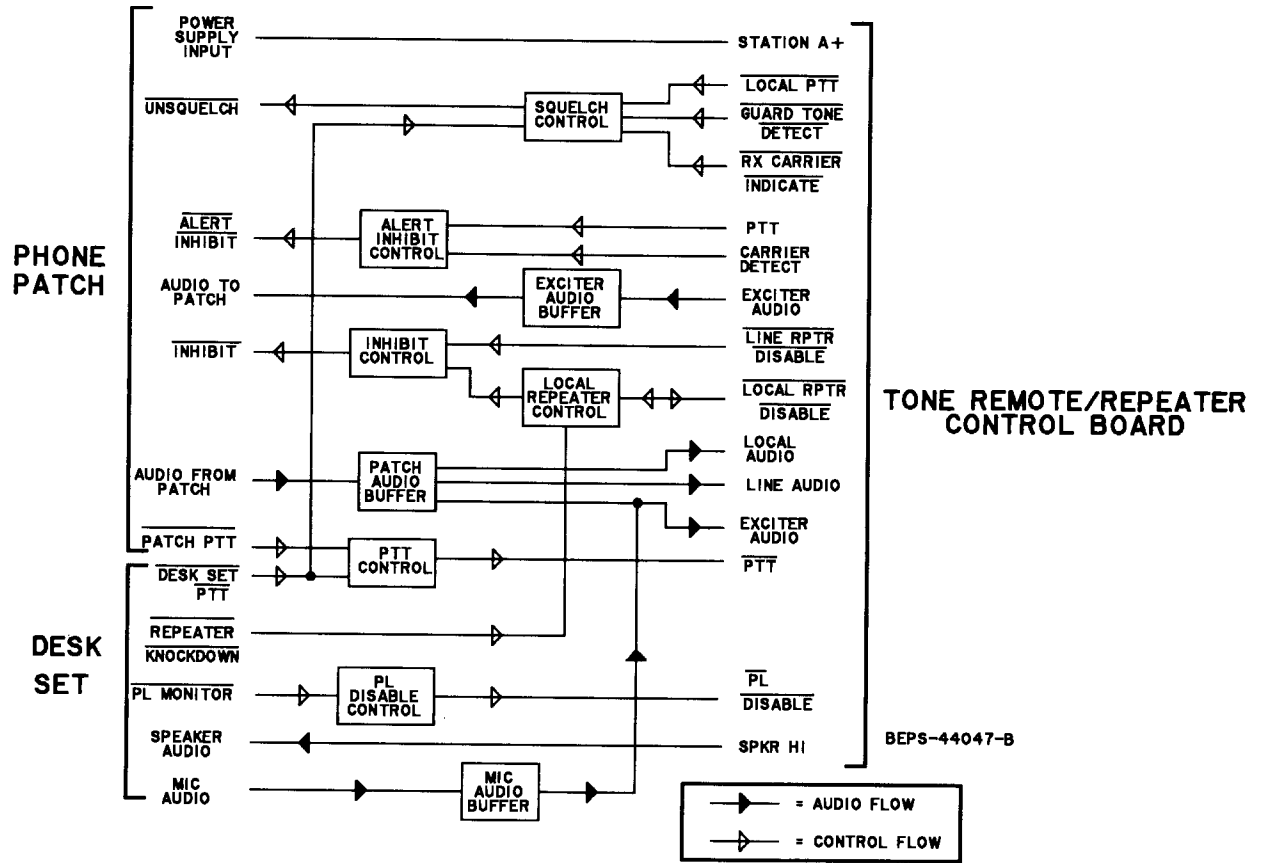

QRN4314A Interface Board
 Block Diagram
 Motorola No. 3-SP3760001-3
 3/12/88

PARTS LIST

REF SYMBOL	MOTOROLA PART NO.	DESCRIPTION
J aux.	0984538E03	<u>CONNECTOR, receptacle:</u> female, 25 contact
P2	-- 1584301K08 3984300K01 2884302K01	<u>CONNECTOR, plug:</u> consists of: HOUSING, connector: 18 position CONTACT, receptacle; 14 used PLUG, polarizing key
P3	-- 1584301K08 3984300K01 2884302K01	consists of: HOUSING, connector: 18 position CONTACT, receptacle; 17 used PLUG, polarizing key
W1	-- 3083339F01	<u>CABLE, assembly:</u> consists of: ref. items J aux., P3 CABLE, 20 conductor
		<u>NON-REFERENCE ITEMS</u>
	0200009627	NUT, hex: 4-40x3/16x3/32"; 2 used
	0400009777	WASHER, lock: #4 med. split; 2 used
	4310646A09	STANDOFF 4-40x0.188"; 2 used

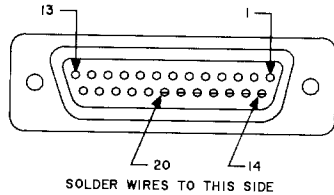

CONN. PIN	SIGNAL DESC
14	GROUND
15	SPEAKER HI
16	MIC HI
17	MIC GROUND
18	PL DISABLE
19	PTT
20	REPEATER KNOCKDOWN

FIGURE A
ELC CONNECTOR WIRING DIAGRAM

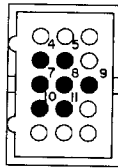

CONN. PIN	SIGNAL DESC
4	PTT
5	REPEATER KNOCKDOWN
7	PL DISABLE
8	MIC HI
9	GROUND
10	MIC GROUND
11	SPEAKER HI

INSERT PINS FROM THIS SIDE

FIGURE B
ELC W/PHONE PATCH CONNECTOR WIRING DIAGRAM

BEPS-44048-A

PARTS LIST

REF SYMBOL	MOTOROLA PART NO.	DESCRIPTION
	2684255L01	SHIELD
	2884506E08	CONNECTOR, plug: subminiature, 25 contact

PARTS LIST

REF SYMBOL	MOTOROLA PART NO.	DESCRIPTION
	1583292K02	HOUSING, receptacle: 15 position
	2984706E06	TERMINAL, chain form; 7 used

PARTS LIST

REF SYMBOL	MOTOROLA PART NO.	DESCRIPTION
	1583293K01	HOUSING, plug: 15 position
	2984706E05	TERMINAL, chain form; 10 used

PARTS LIST

REF SYMBOL	MOTOROLA PART NO.	DESCRIPTION
	2884476G01	CONNECTOR, coaxial plug: male
	2884579F04	CONNECTOR, UHF plug: male
	3084173E01	CABLE, coax, double shielded; 36" used

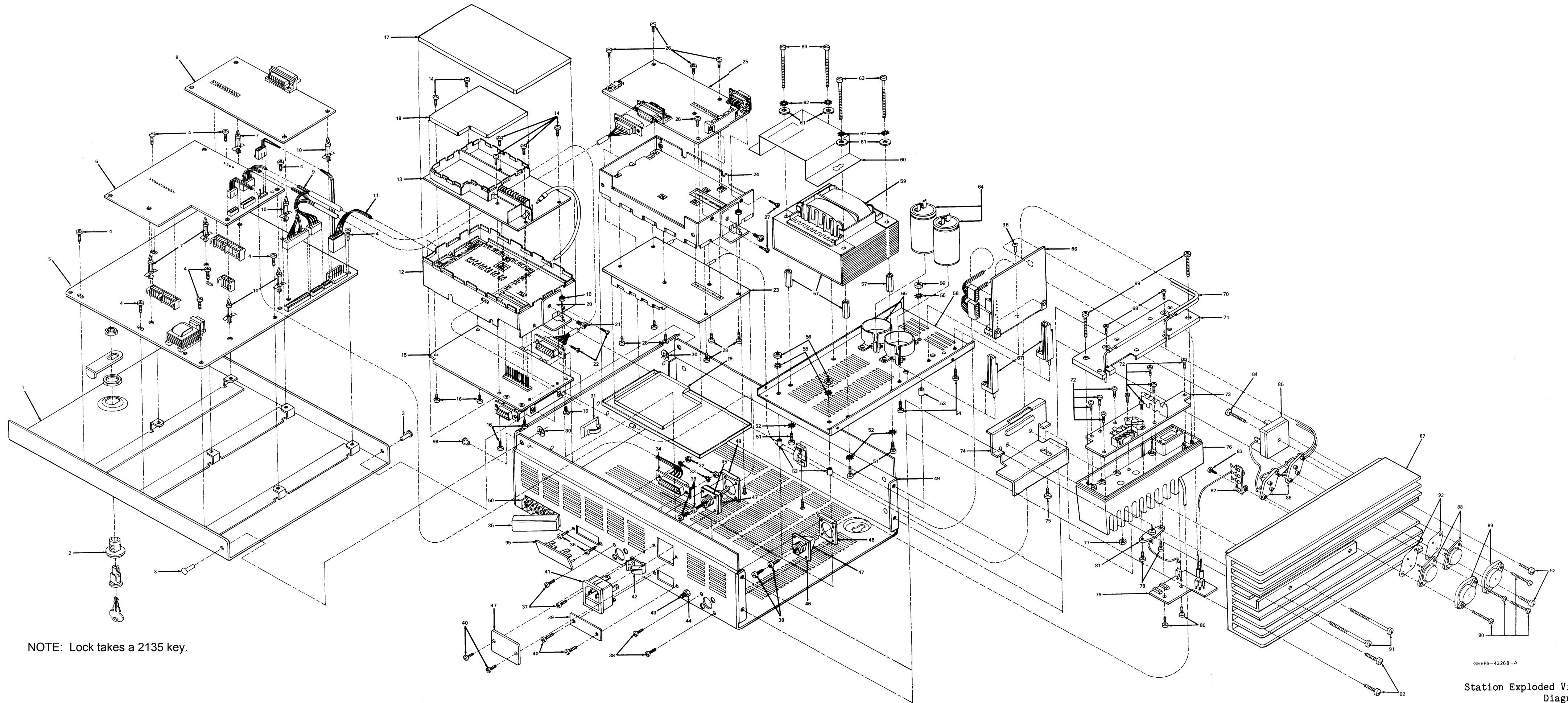

NOTE: Lock takes a 2135 key.

Station Exploded View
Diagram
Motorola No. 9-SP3760001-1
3/30/87

GEEPS-43268-A

PARTS LIST

REF SYMBOL	MOTOROLA PART NO.	DESCRIPTION
1	15-82121R01	Door
2	55-03454A01	Lock, assembly includes cam and nuts (See note)
3	5-03465A01	Pivot, pin
4	3-80269H08	Screw, tapping: M3 x 8 mm (BLK); 9 used
5	--	TRC, control board
6	--	ETRC, board
7	43-03463A01	Stand off; 3 used
8	--	Rat decoder, board
9	30-03469A04	Cable, assembly
10	43-03462A01	Standoff, PC flex; 4 used
11	--	Cable, TRC power (DC output)
12	27-80174H01	Chassis, ELM
13	--	Receiver, RF board
14	3-02607B02	Screw, tapping: M3 x 6 mm; 6 used
15	--	Receiver, command board
16	3-02607B02	Screw, tapping: M3 x 6 mm; 5 used
17	15-80129J01	Cover, chassis; 2 used
18	15-80136J01	Cover, RF shield
19	2-84784B05	Nut, M3 mm
20	7-82406R01	Bracket, ELM; 2 used
21	3-80165J06	Screw, machine: M5 x 8 mm; 2 used
22	3-80269H02	Screw, tapping: M2.5 x 8 mm; 2 used
23	--	Transmitter, RF board
24	27-80174H01	Chassis, ELM
25	--	Transmitter, command board
26	3-02607B02	Screw, tapping: M3 x 6 mm; 5 used
27	3-80269H02	Screw, tapping: M2.5 x 8 mm; 2 used
28	3-02607B02	Screw, tapping: M3 x 6 mm; 6 used
29	15-80136J01	Cover, RF shield
30	2-03455A01	Nut, push-on; 2 used
31	42-10347A03	Clamp, cable; 2 used
32	2-84784B05	Nut, M3; 2 used
33	4-84718C04	Washer, starlock M3; 2 used
34	28-84506E08	Connector, see electrical parts list
35	15-03441A01	Cover, phone line
36	3-80269H08	Screw, tapping: M3 x 8 mm (BLK); 2 used
37	3-80269H06	Screw, tapping: M3 x 16 mm; 2 used
38	3-82069H08	Screw, tapping: 3 x 8 mm; 6 used
39	15-03426A01	Cover, battery option
40	3-80269H08	Screw, tapping: M3 x 8 mm; 4 used
41	28-02138M04	Connector, A/C with fuse
42	42-03459A01	Clip, strain relief
43	3-08634B25	Screw, machine: M5 x 16 mm
44	2-84719C01	Nut, M5
45	15-03473A01	Housing, RX LPF
46	9-82442E01	Connector, UHF
47	15-483599	Hood, connector; 2 used
48	7-03432A01	Bracket, UHF connector; 2 used

Note: Lock takes a 2135 key, P/N 5500893872.

Station Exploded View
 Motorola Parts List (PL-10169-0)
 9PL-SP3760001-2
 (Sheet 1 of 3) 3/30/87

PARTS LIST

REF SYMBOL	MOTOROLA PART NO.	DESCRIPTION
49	15-82120R01	Housing, radio
50	31-84145N03	Terminal, block
51	3-80165J07	Screw, machine: M4 x 10 mm; 4 used
52	4-84718C02	Washer, external lock (M4); 4 used
53	4-84717C24	Washer, spacer; 3 used
54	3-82069H08	Screw, tapping: M3 x 8 mm; 2 used
55	4-84718C04	Washer, starlock (M3); 3 used
56	2-84784B05	Nut, M3 mm; 3 used
57	3-84893D02	Screw, distance (standoff); 4 used
58	27-82118R01	Chassis, power supply
59	25-82169R01	Transformer
60	14-03440A01	Insulator, A/C
61	4-84717C01	Washer, flat: M4; 4 used
62	4-84718C02	Washer, external lock; 4 used
63	3-81065J09	Screw, machine: M4 x 50 mm; 4 used
64	8-84700C01	Capacitor; 2 used
65	42-02211B01	Bracket, capacitor; 2 used
66	--	Regulator, board
67	46-84203E01	Card guide; 2 used
68	3-02607B02	Screw, tapping: M3 x 6 mm; 2 used
69	3-80269H09	Screw, tapping: M5 x 20 mm; 2 used
70	30-80116K06	Cable, coaxial; 2 used
71	15-03424A01	Cover, PA
72	3-02607B01	Screw, tapping: M3 x 8 mm; 9 used
73	--	PA board
74	42-82405R01	Clamp, PA
75	3-80165J07	Screw, machine; M4 x 10 mm
76	26-80176H08	Heat Sink, PA
77	2-7003	Nut, 8-32 mm
78	3-02607B02	Screw, tapping: M3 x 6 mm; 2 used
79	--	Current limit board
80	3-02607B01	Screw, tapping: M3 x 8 mm; 2 used
81	9-80038K02	Connector, power
82	31-122068	Terminal, strip
83	3-80269H08	Screw, tapping: M3 x 8 mm
84	3-80269H07	Screw, tapping: M4 x 20 mm
85	48-02081M06	Bridge, rectifier
86	9-02088M01	Socket, transistor; 2 used
87	26-82152R01	Heat Sink, main
88	48-02081B29	Transistor, power; 2 used
89	14-02309M01	Cover, transistor; 2 used
90	3-84723C16	Screw, machine: M3 x 25 mm; 4 used
91	3-80165J08	Screw, machine: M4 x 60 mm; 2 used
92	3-80269H07	Screw, tapping: M4 x 20 mm; 4 used

PARTS LIST

REF SYMBOL	MOTOROLA PART NO.	DESCRIPTION
93	14-02161M01	Insulator, transistor; 2 used
94	NOT USED	
95	38-83665N01	Cap
96	3-84723C29	Screw, machine: M3 x 4 mm
97	15-03475A01	Cover, AC connector
98	38-03460A01	Plug, button; 9 used

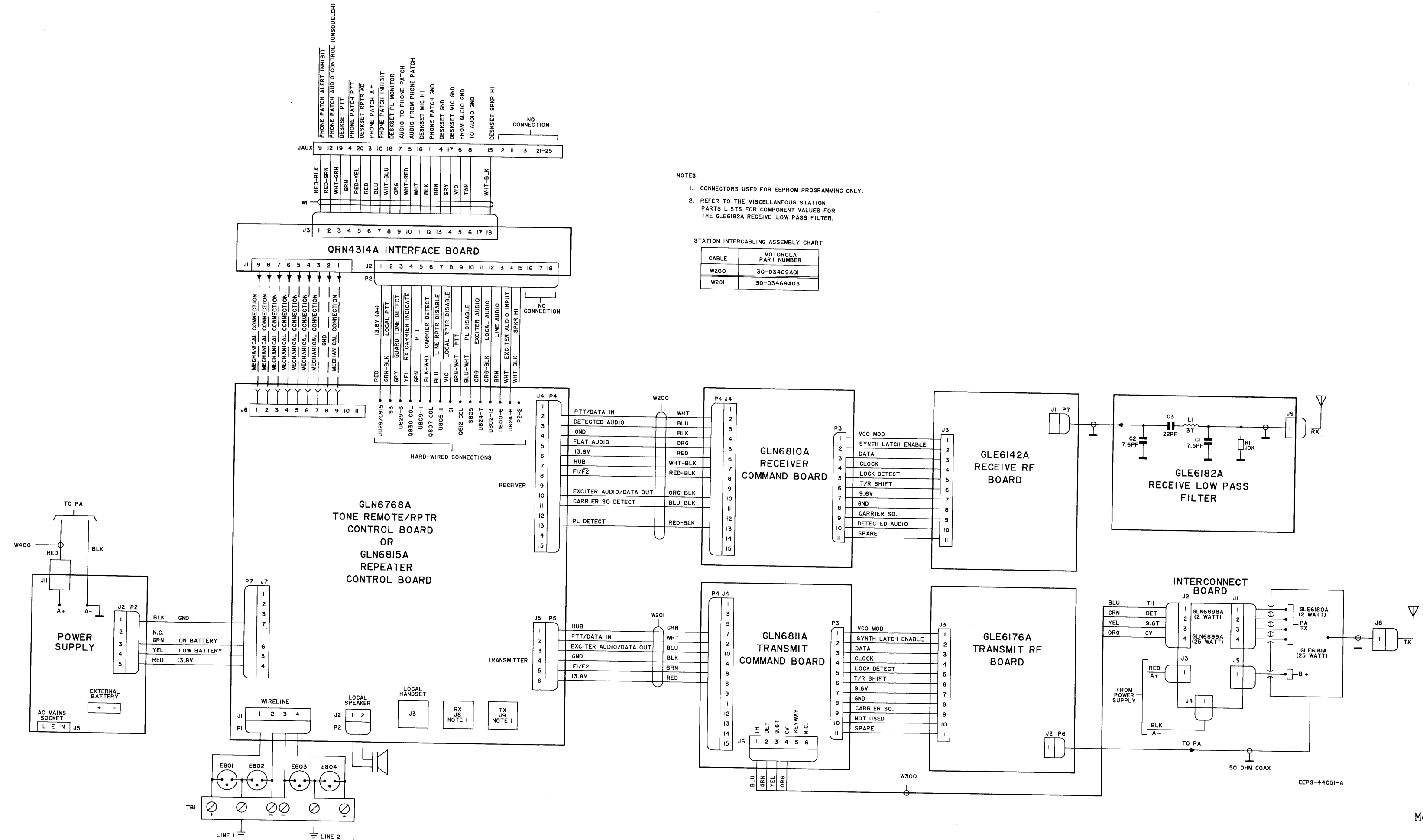

- NOTES:
- CONNECTORS USED FOR EEPROM PROGRAMMING ONLY.
 - REFER TO THE MISCELLANEOUS STATION PARTS LISTS FOR COMPONENT VALUES FOR THE GLE6182A RECEIVE LOW PASS FILTER.

STATION INTERCABLING ASSEMBLY CHART

CABLE	MOTOROLA PART NUMBER
W200	30-03469A01
W201	30-03469A03

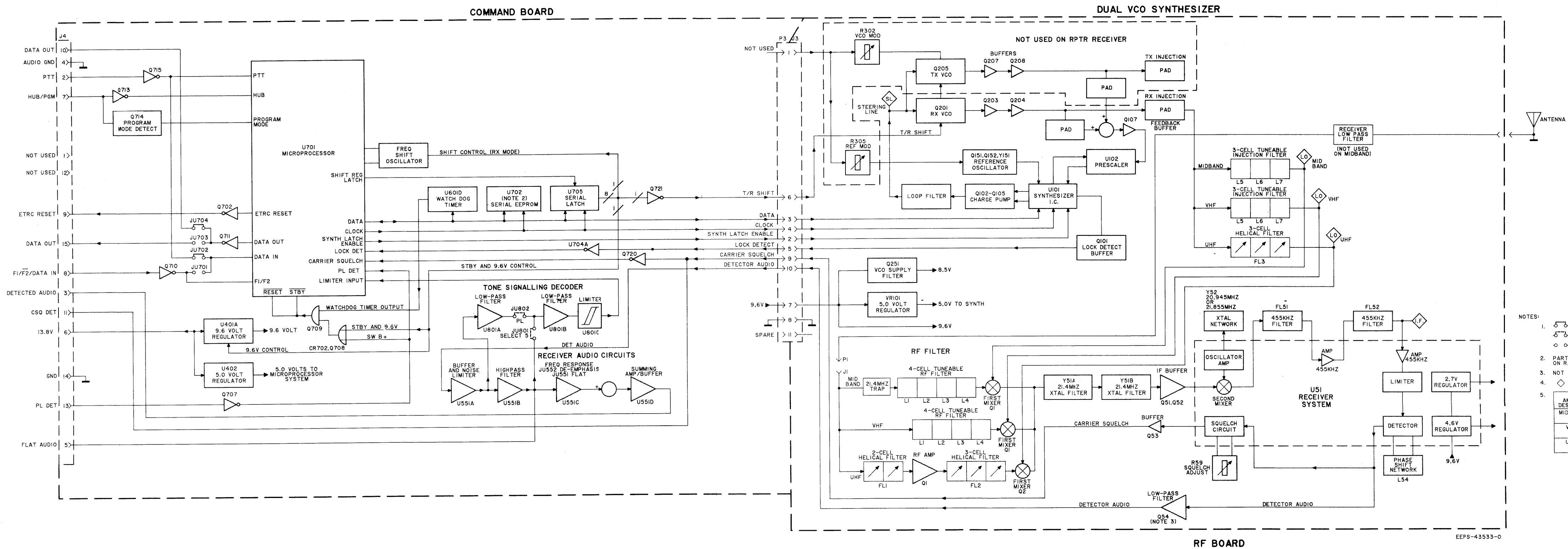

NOTES:

- JUMPER INSERTED.
 - JUMPER DEPENDS ON MODEL TYPE AND OPTIONS ORDERED.
 - JUMPER NOT INSERTED.
- PART TYPE AND USAGE DEPENDS ON RADIO TYPE AND OPTIONS.
- NOT IN ALL VERSIONS.
- TEST POINT

POWER AMPLIFIER DESIGNATORS	BUFFER	CONTROLLED STAGE	10WATT FINAL/25WATT DRIVER	25WATT FINAL
MIDBAND 10W	Q110	Q120	Q130	NOT USED
25W	Q120	Q120	Q120	Q1240
VHF 10W	Q130	Q130	Q130	NOT USED
25W	Q140	Q140	Q140	Q1440
UHF 10W	Q150	Q150	Q150	NOT USED
25W	Q160	Q160	Q160	Q1640

EEPS-43533-0

COMMAND BOARD

RF POWER AMPLIFIER BOARD

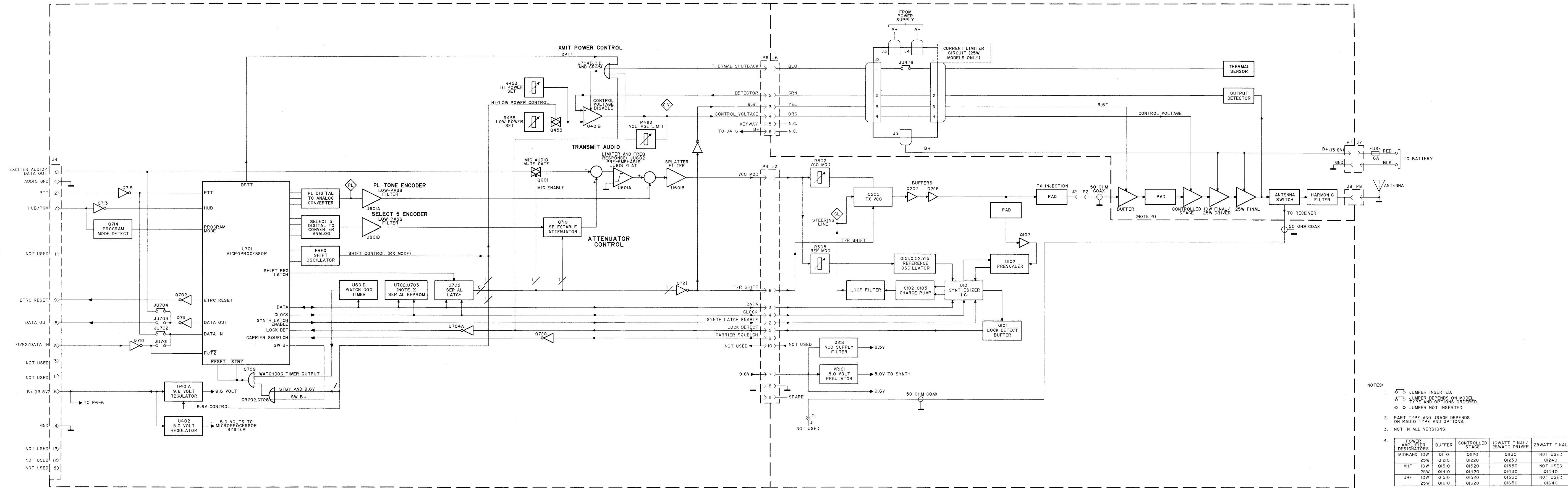

- NOTES:
- JUMPER INSERTED.
 - JUMPER DEPENDS ON MODEL TYPE AND OPTIONS ORDERED.
 - JUMPER NOT INSERTED.
 - PART TYPE AND USAGE DEPENDS ON RADIO TYPE AND OPTIONS.
 - NOT IN ALL VERSIONS.
 - | POWER AMPLIFIER DESIGNATORS | BUFFER | CONTROLLED STAGE | 10WATT FINAL/25WATT DRIVER | 25WATT FINAL |
|-----------------------------|--------|------------------|----------------------------|--------------|
| MIDBAND 10W | Q110 | Q120 | Q130 | NOT USED |
| 25W | Q120 | Q1220 | Q1230 | Q1240 |
| VHF 10W | Q130 | Q1320 | Q1330 | NOT USED |
| 25W | Q140 | Q1420 | Q1430 | Q1440 |
| UHF 10W | Q150 | Q1520 | Q1530 | NOT USED |
| 25W | Q160 | Q1620 | Q1630 | Q1640 |

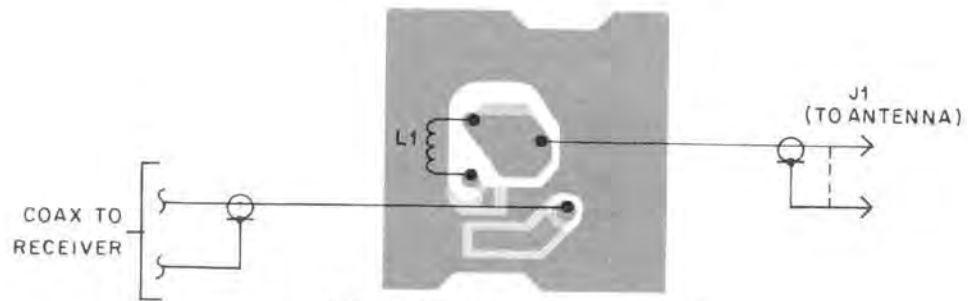

COMP SIDE ● BD-AEPS-43514-A
 SOLD SIDE ● BD-AEPS-43515-A
 OL BD-BEPS-43516-A

SHOWN FROM COMPONENT SIDE

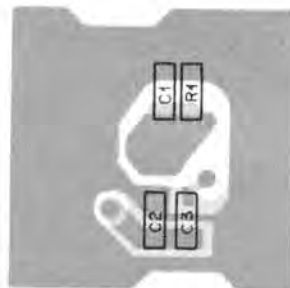

COMP SIDE ● BD-AEPS-43514-A(REV)
 SOLD SIDE ● BD-AEPS-43515-A(REV)
 OL-BEPS-43517-0

SHOWN FROM SOLDER SIDE

PARTS LIST

REF SYMBOL	MOTOROLA PART NO.	DESCRIPTION
C1, 2	21-11031A12	<u>CAPACITOR, fixed:</u> 7.5 pF $\pm 5\%$; 50 V (chip)
C3	21-11031A23	22 pF $\pm 5\%$; 50 V (chip)
J9	9-82442E01	<u>CONNECTOR:</u> female, single contact
L1	24-11030A02	<u>COIL, rf:</u> 3 turns; orange
R1	6-11024A73	<u>RESISTOR, fixed:</u> 10k $\pm 5\%$; 1/8 W (chip)
		<u>MECHANICAL PARTS:</u>
	3-80269H06	SCREW, mounting tapt M3 x 0.5 mm; 2 used
	7-03432A01	BRACKET
	15-843599	HOOD, receptacle
	15-03473A01	HOUSING, filter
	30-80116K05	CABLE, coaxial

PARTS LIST

REF SYMBOL	MOTOROLA PART NO.	DESCRIPTION
E801 thru 804	80-83029H01	<u>SPARK GAP:</u> 230 V DC
P1, 2	15-82694R03	<u>CONNECTOR, plug:</u> housing, 4-position
P3	39-82693R02	receptacle, crimp snap; 4 used
P6	28-02098M02	female; single contact
P11	15-80151J01	housing, 4-position
	9-80257H01	female, crimp-on lug; 4 used
	28-02098M02	female; single contact
TB1	31-84145N03	<u>TERMINAL BOARD:</u> 6-position
W200	30-03469A01	<u>CABLE, assembly:</u> 15-conductor w/connector; includes P4
W201	30-03469A03	8-conductor w/connector; includes P5 (GKN6163A only)
W300	SEE NOTE	power control cable 4-wire; includes P2 and P6
W400	30-82724C01	A+ cable; includes P3 and P11
	38-83665N01	<u>MECHANICAL PARTS:</u> CAP, connector
	42-10217A02	STRAP, tie: .091 x 3.62"; 7 used
	22-80172J01	PIN, polarizing (P6) (GKN6162A only)

NOTE: This referenced item not available as a single replaceable part. Obtain separate parts and assemble as required. Installation of W300 determined by station type. W300 connects PA to transmit chassis in a repeater station, or it connects PA to transceiver chassis in a base station.

PARTS LIST

REF SYMBOL	MOTOROLA PART NO.	DESCRIPTION
	3002695B10	CABLE, 3-wire; includes plug

PARTS LIST

REF SYMBOL	MOTOROLA PART NO.	DESCRIPTION
	6584711C11	FUSE, 110/120 V ac, T3.16A; 250 V

PARTS LIST

REF SYMBOL	MOTOROLA PART NO.	DESCRIPTION
	6584711C21	FUSE, 110/120 V ac, slow-blow; 5A; 250 V

PARTS LIST

REF SYMBOL	MOTOROLA PART NO.	DESCRIPTION
U702	GLN6879A or GLN6880A	<u>INTEGRATED CIRCUIT:</u> (SEE NOTE) EPROM: 128 x 8 EPROM: 128 x 8

NOTE: For optimum performance, diodes, transistors, crystals and integrated circuits must be ordered by Motorola part numbers.

PARTS LIST

REF SYMBOL	MOTOROLA PART NO.	DESCRIPTION
	3-02607B02	SCREW, tapt M3 x 6 mm; 11 used
	15-80129J01	COVER
	15-80136J01	COVER, rf shield
	15-80156J01	COVER, chassis
	26-80198J01	SHIELD, rf

PARTS LIST

REF SYMBOL	MOTOROLA PART NO.	DESCRIPTION
	2-03455A01	NUT, lock; 2 used
	2-84784B04	NUT, M3, hex; 2 used
	3-80165J06	SCREW, machine: M5 x 0.8 x 8 mm; 2 used
	3-80165J08	SCREW, machine: M4 x 0.7 mm; 2 used
	3-80269H06	SCREW, tapt: M3 x 0.5 mm; 2 used
	3-80269H08	SCREW, tapt: M3 x 0.5 mm; 15 used
	4-84718C05	LOCKWASHER, A3.7 MM; 2 used
	5-03470A01	GROMMET
	7-82406R01	BRACKET, PA; 2 used
	15-03441A01	COVER, terminal block
	15-82121R01	COVER, housing
	38-03460A01	BUTTON; 3 used
	42-03459A01	CLIP
	42-10347A01	CLIP, cable; 2 used
	42-10347A04	CLAMP, cable; 2 used
	54-02334M01	LABEL
	54-02335M01	LABEL; 3 used
	55-03454A01	LOCK

PARTS LIST

REF SYMBOL	MOTOROLA PART NO.	DESCRIPTION
	3-84724C02	SCREW, tapping: 4-8 x 38"; 3 used
	38-03460A01	BUTTON, plug; 6 used

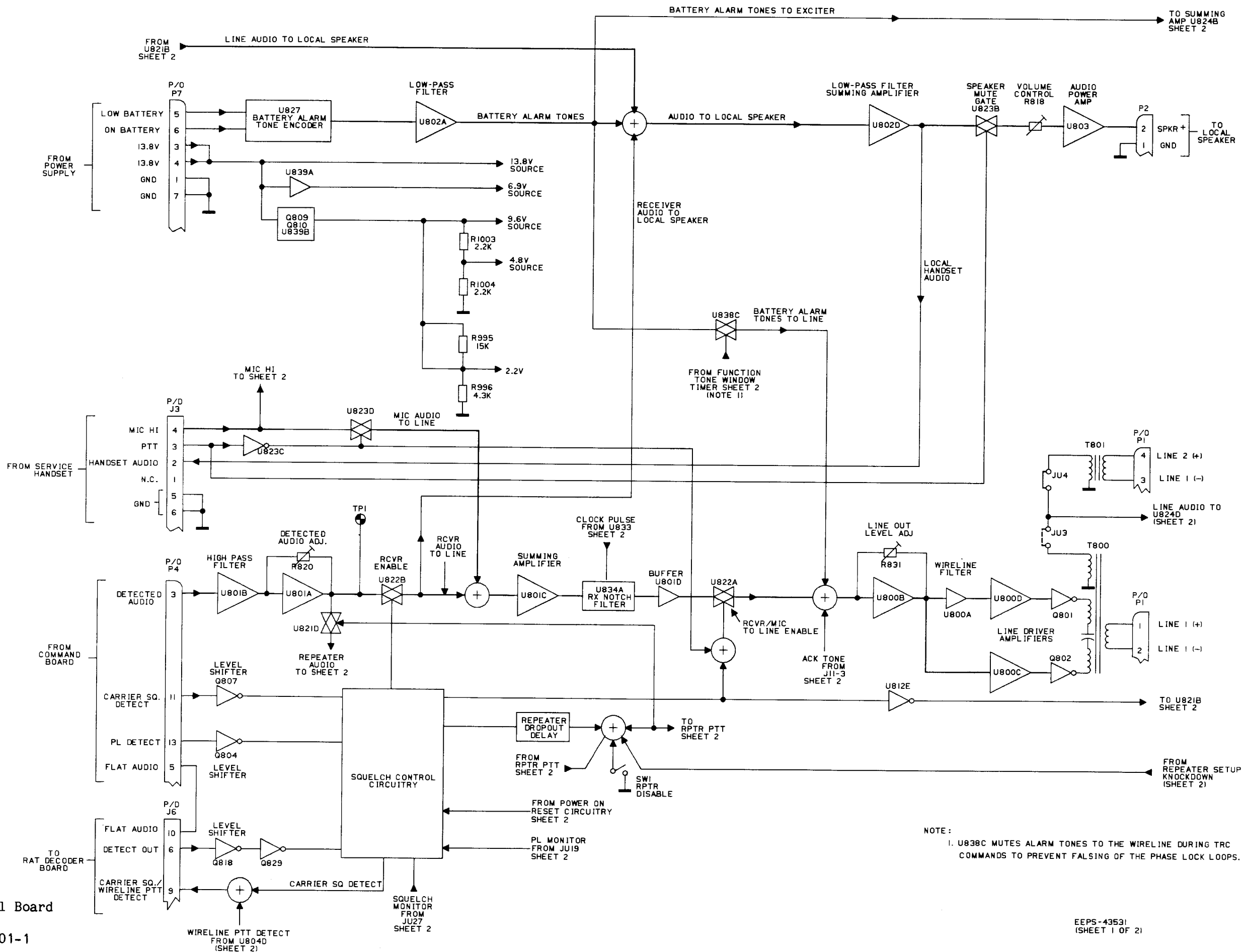

Tone Remote/RPTR Control Board
Block Diagram
Motorola No. 26-SP3760001-1
(Sheet 1 of 2)
3/30/87

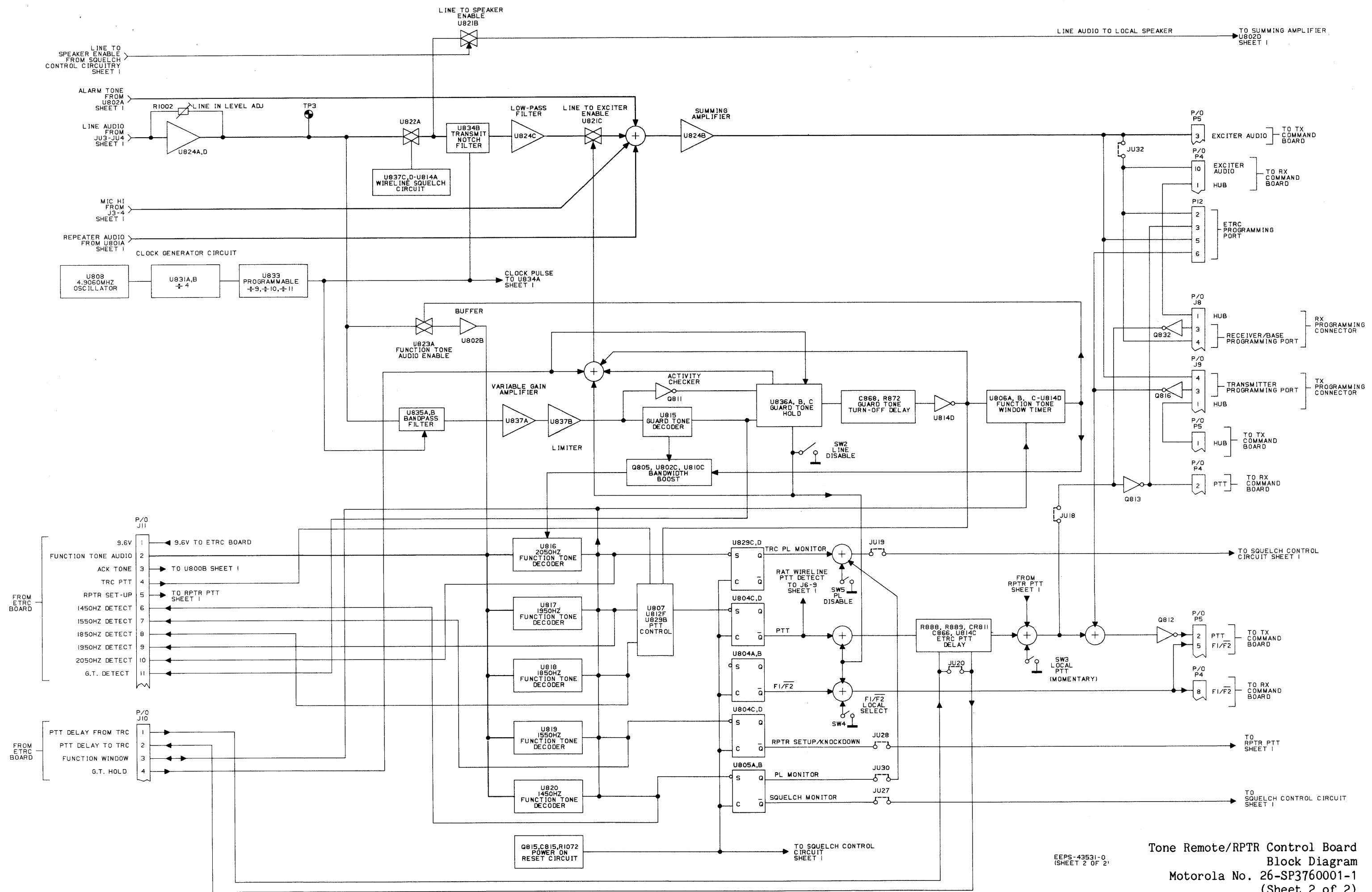

EEPS-43531-0
(SHEET 2 OF 2)

Tone Remote/RPTR Control Board
Block Diagram
Motorola No. 26-SP3760001-1
(Sheet 2 of 2)
3/30/87

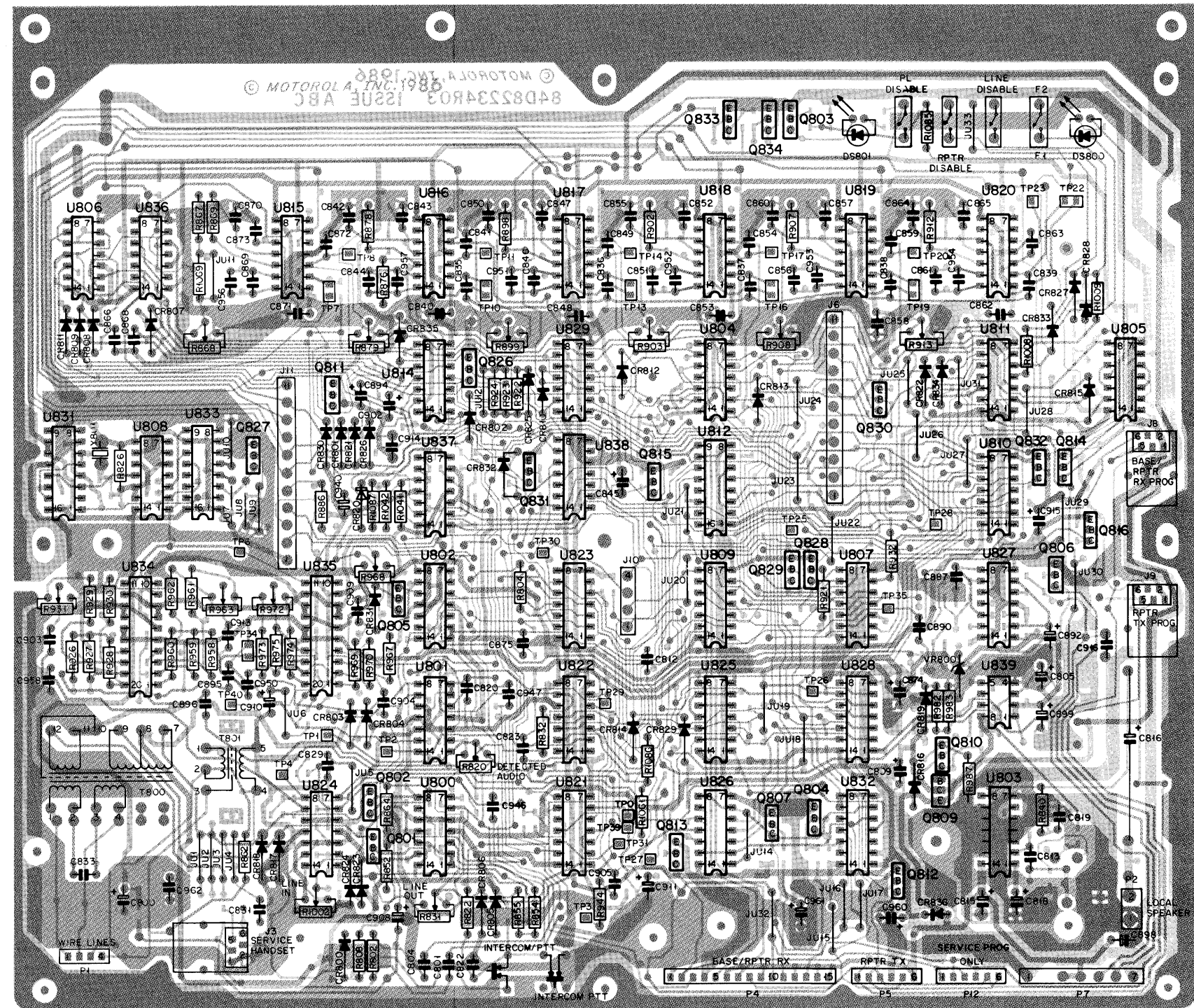

COMPONENT SIDE © BD-DEPS-41902-0
 SOLDER SIDE © BD-DEPS-41903-0
 JL-EEPS-41904-0

SHOWN FROM COMPONENT SIDE

TO RAT BOARD J6

11	NOT USED
10	RX FLAT AUDIO
9	SQUELCH MODE
8	GND
7	9.6V
6	RAT SQUELCH FLAG
5	NOT USED
4	NOT USED
3	NOT USED
2	NOT USED
1	NOT USED

SERVICE HANDSET J3

5	ANALOG GND
4	MIC HI
3	MIC PTT
2	HANDSET AUDIO
1	NOT USED

TO POWER SUPPLY P7

1	GND
2	N.C.
3	13.8V
4	13.8V
5	LOW BATTERY ON BATTERY
6	ON BATTERY
7	GND

WIRE LINE CONNECTOR P1

1	LINE 1 (+)
2	LINE 1 (-)
3	LINE 2 (-)
4	LINE 2 (+)

LOCAL SPEAKER P2

2	SPKR +
1	SPKR -

TO ETRC BOARD J11

11	GT DETECT
10	2050 HZ DETECT
9	1950 HZ DETECT
8	1850 HZ DETECT
7	1550 HZ DETECT
6	1450 HZ DETECT
5	RPTR SET-UP
4	PTT (FROM ETRC)
3	ACK TONE
2	FUNCTION TONE AUDIO
1	9.6V

BASE DETAIL TOP VIEW
 ALL TRANSISTORS
 C B E

TO ETRC BOARD J10

4	GT HOLD
3	FT WINDOW
2	PTT DELAY TO ETRC
1	PTT DELAY FROM ETRC

RPTR TX CONNECTOR P5

1	HUB
2	PTT/DATA IN
3	EXCITER AUDIO OUT/DATA OUT
4	GND
5	F1/F2 SELECT
6	13.8V

BASE/RPTR RX CONNECTOR F4

1	NOT USED
2	NOT USED
3	RX DETECTED AUDIO
4	GND
5	RX FLAT AUDIO
6	13.8V
7	HUB
8	F1/F2 SELECT
9	NOT USED
10	NOT USED
11	CARRIER SQUELCH INDICATE
12	NOT USED
13	PL INDICATE
14	NOT USED
15	NOT USED

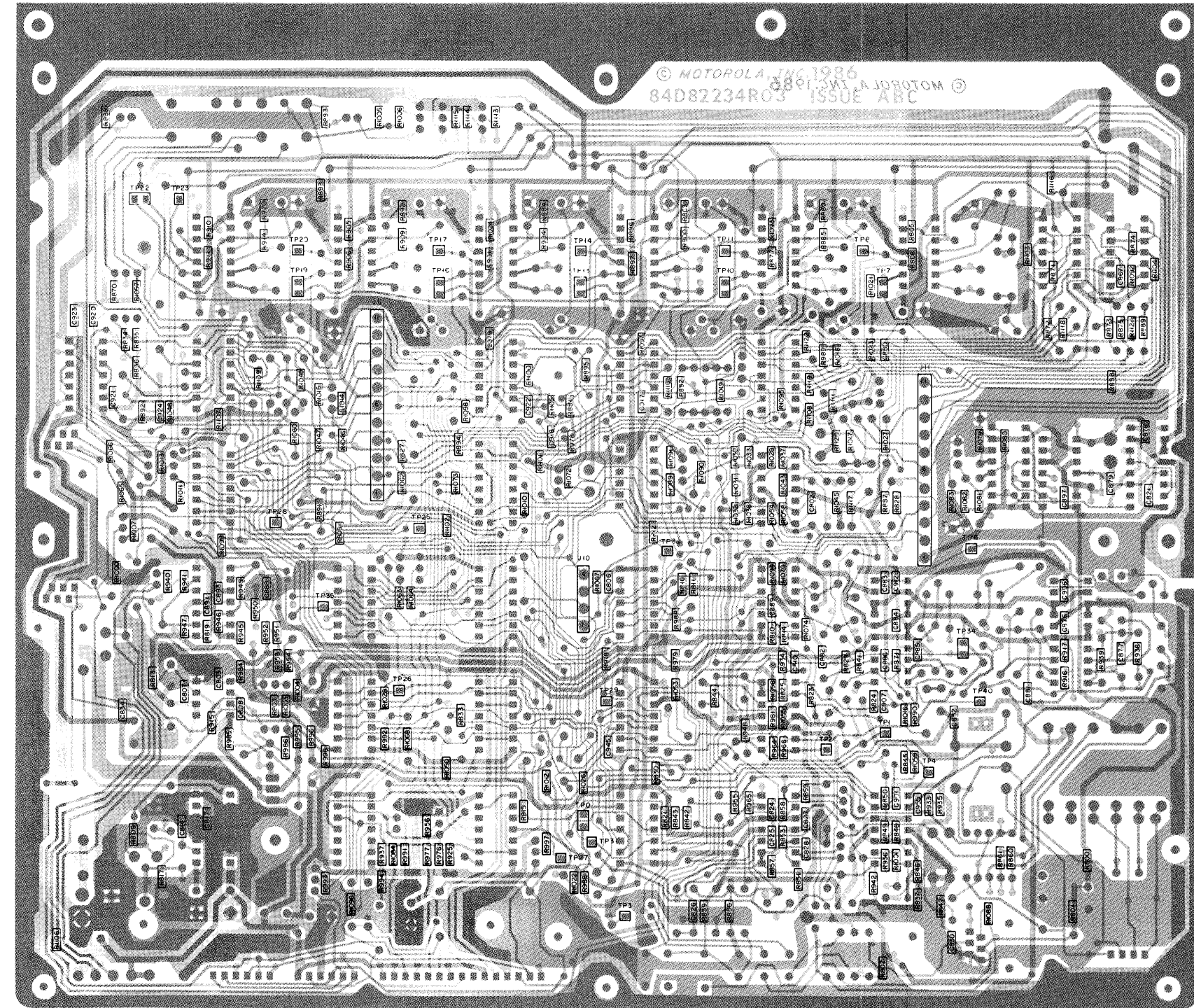

COMPONENT SIDE © BD-DEPS-41902-0 (REV)
 SOLDER SIDE © BD-DEPS-41903-0 (REV)
 OL-DEPS-41905-0

SHOWN FROM SOLDER SIDE

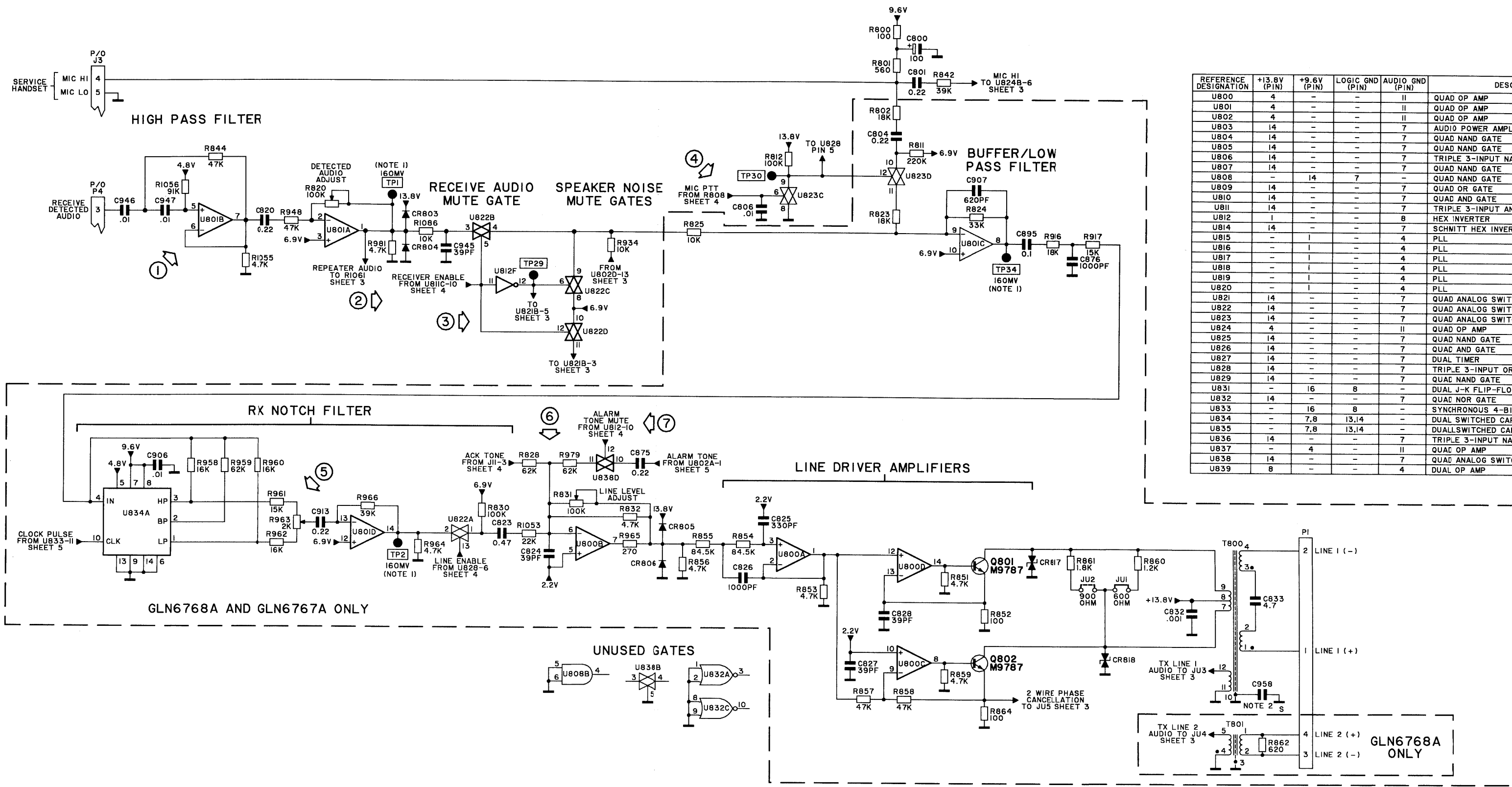

REFERENCE DESIGNATION	+13.8V (PIN)	+9.6V (PIN)	LOGIC GND (PIN)	AUDIO GND (PIN)	DESCRIPTION
U800	4	-	-	11	QUAD OP AMP
U801	4	-	-	11	QUAD OP AMP
U802	4	-	-	11	QUAD OP AMP
U803	14	-	-	7	AUDIO POWER AMPLIFIER
U804	14	-	-	7	QUAD NAND GATE
U805	14	-	-	7	QUAD NAND GATE
U806	14	-	-	7	TRIPLE 3-INPUT NAND GATE
U807	14	-	-	7	QUAD NAND GATE
U808	-	14	7	-	QUAD NAND GATE
U809	14	-	-	7	QUAD OR GATE
U810	14	-	-	7	QUAD AND GATE
U811	14	-	-	7	TRIPLE 3-INPUT AND GATE
U812	1	-	-	8	HEX INVERTER
U814	14	-	-	7	SCHMITT HEX INVERTER
U815	-	1	-	4	PLL
U816	-	1	-	4	PLL
U817	-	1	-	4	PLL
U818	-	1	-	4	PLL
U819	-	1	-	4	PLL
U820	-	1	-	4	PLL
U821	14	-	-	7	QUAD ANALOG SWITCH
U822	14	-	-	7	QUAD ANALOG SWITCH
U823	14	-	-	7	QUAD ANALOG SWITCH
U824	4	-	-	11	QUAD OP AMP
U825	14	-	-	7	QUAD NAND GATE
U826	14	-	-	7	QUAD AND GATE
U827	14	-	-	7	DUAL TIMER
U828	14	-	-	7	TRIPLE 3-INPUT OR GATE
U829	14	-	-	7	QUAD NAND GATE
U831	-	16	8	-	DUAL J-K FLIP-FLOP
U832	14	-	-	7	QUAD NOR GATE
U833	-	16	8	-	SYNCHRONOUS 4-BIT BINARY COUNTER
U834	-	7,8	13,14	-	DUAL SWITCHED CAPACITOR FILTER
U835	-	7,8	13,14	-	DUAL SWITCHED CAPACITOR FILTER
U836	14	-	-	7	TRIPLE 3-INPUT NAND GATE
U837	-	4	-	11	QUAD OP AMP
U838	14	-	-	7	QUAD ANALOG SWITCH
U839	8	-	-	4	DUAL OP AMP

NOTES:
 1. IN RX-MODE WITH ON-CHANNEL SIGNAL, 1KHZ MODULATION AT 60% FSD.
 2. REFER TO PARTS LIST FOR VALUE.

EEPS-41901-B
 (SHEET 1 OF 4)

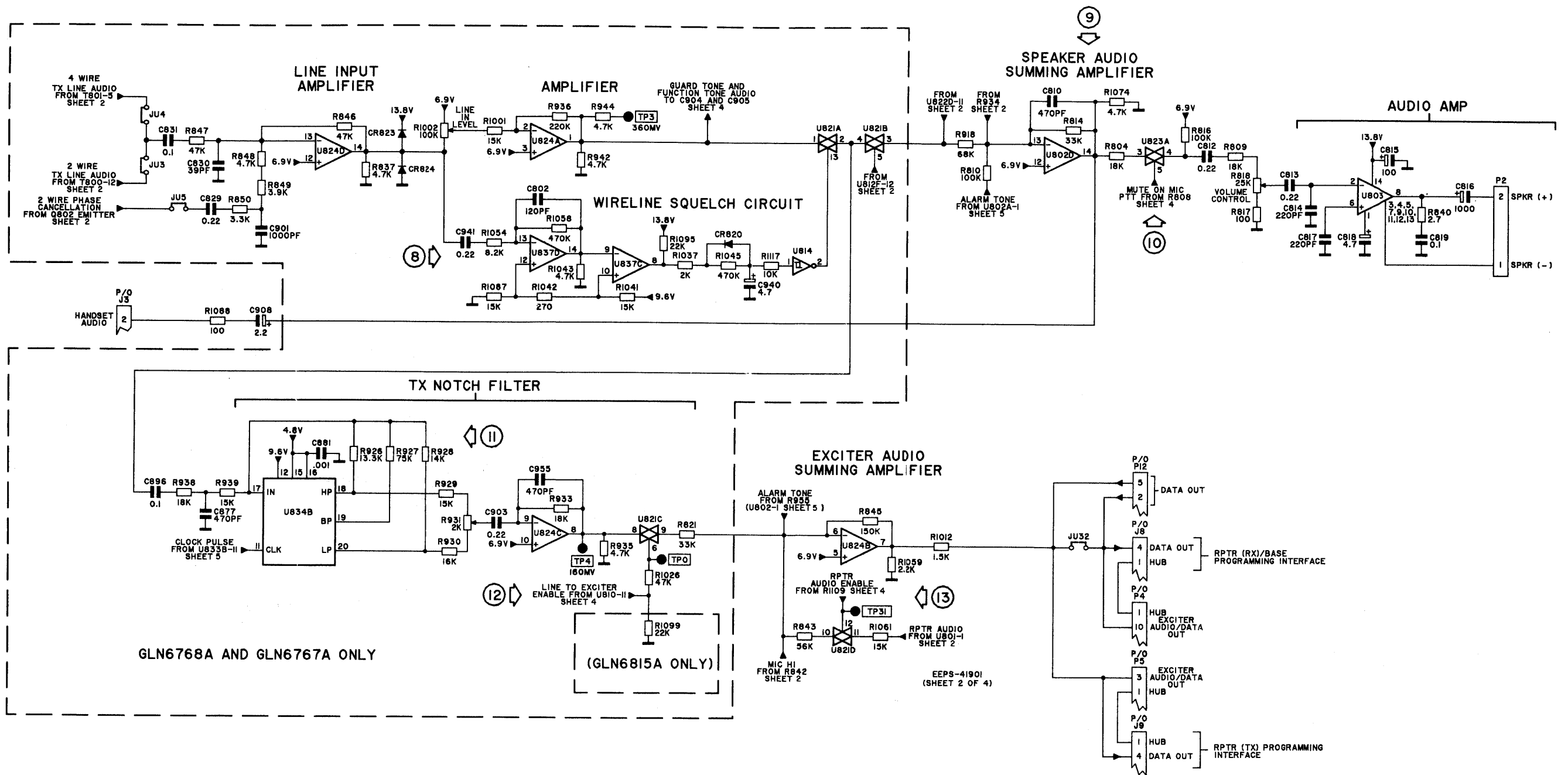

GLN6768A and GLN6815A
 Tone Remote/RPTR Control Board
 Schematic Diagram
 Motorola No. 27-SP3760001-2
 (Sheet 3 of 6)
 3/12/88

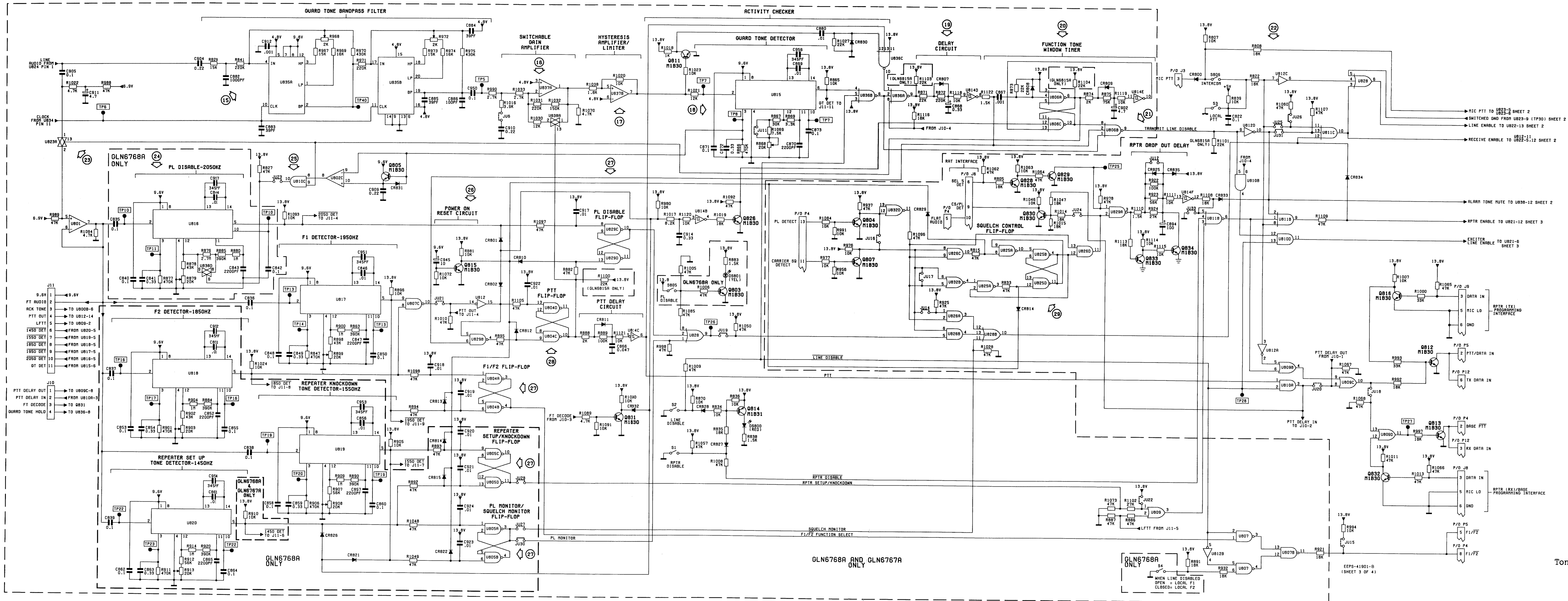

GLN6768A and GLN6815A
Tone Remote/RPTR Control Board
Schematic Diagram
Motorola No. 27-SP3760001-2
(Sheet 4 of 6)
3/12/88

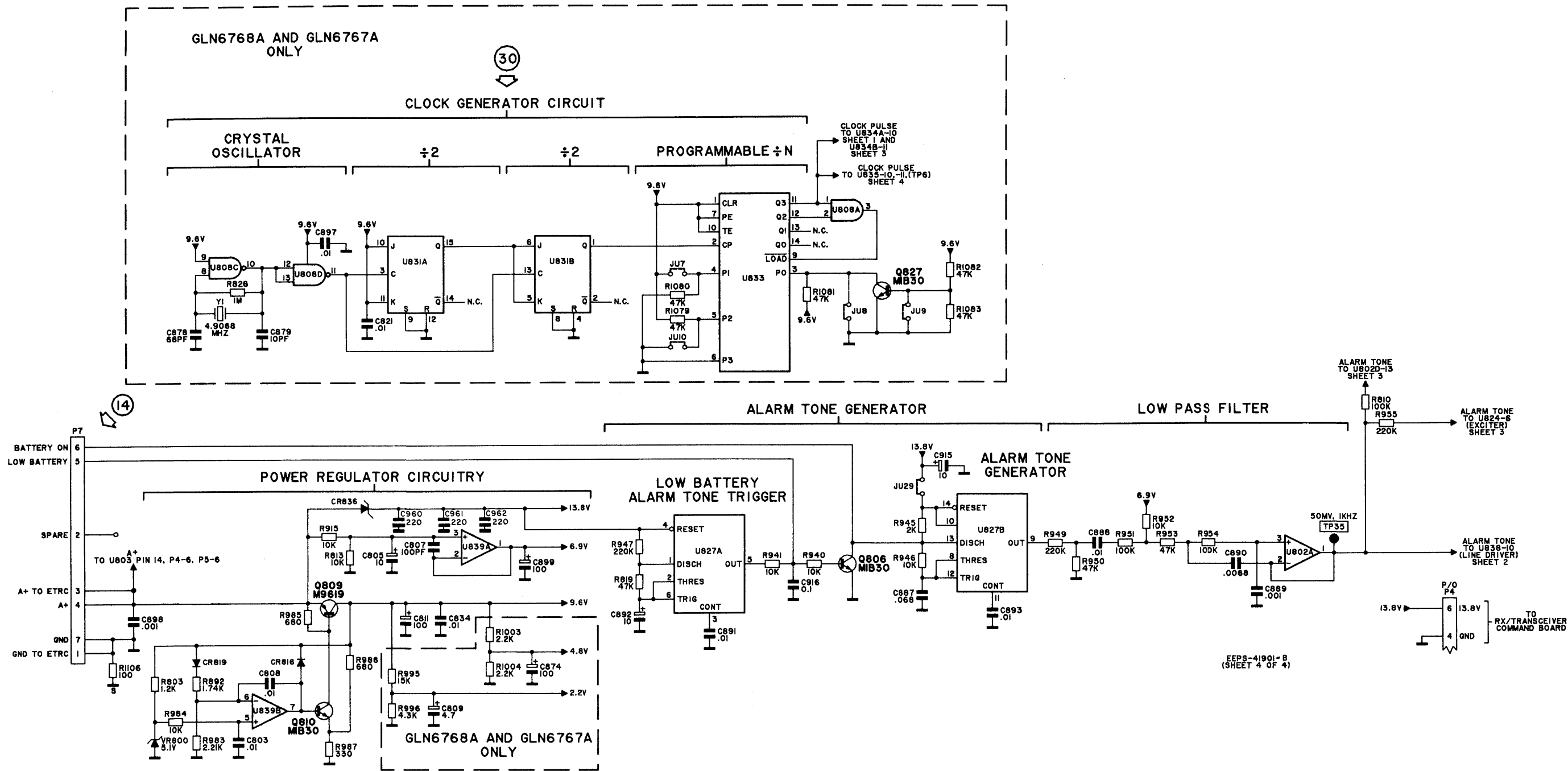

GLN6768A and GLN6815A
 Tone Remote/RPTR Control Board
 Schematic Diagram
 Motorola No. 27-SP3760001-2
 (Sheet 5 of 6)
 3/12/88

Note 1. High pass input amplifier U801B passes audio frequencies above 300 Hz.

Note 2. RECEIVER ENABLE input from U811C-10 goes high upon one of the following conditions, depending upon options and jumper status: PL "AND" carrier squelch detect, PL squelch detect, or squelch monitor input from the control console.

Note 3. Speaker noise mute gates U822C and U822D provide additional attenuation to the RECEIVE DETECTED AUDIO to prevent receiver noise from being heard in the station speaker under squelch conditions.

Note 4. MIC PTT goes low upon activating the service handset microphone PTT. This action enables U822A and disables U823C which, in turn, enables U823D allowing service handset microphone audio to be sent to the line driver circuits and to the exciter.

Note 5. The RX Notch Filter circuit, U834A and U801D, attenuates the guard tone frequency while allowing all others to pass.

Note 6. ACK TONE/ALARM TONE/RECEIVE AUDIO summing point.

Note 7. Mute gate U838D mutes alarm tones when guard tone is present.

Note 8. Wireline Squelch Circuit (U837D, U837C, and U814A) senses voice audio from the wireline to enable U821A to pass wireline audio to the exciter. Wireline levels below -55 dBm will be muted.

Note 9. Speaker summing amplifier U802D amplifies receive audio, line audio, and/or alarm tone audio depending upon the condition of gates U822C, U822D, U821A, and U821B.

Note 10. Speaker amplifier mute gate U823 mutes speaker audio during MIC PTT (also local PTT if the intercom switch is in the "ON" position).

Note 11. The TX Notch Filter (U834B and U824C) notches out the guard tone frequency to prevent transmission of guard tone.

Note 12. LINE TO EXCITER ENABLE is normally high. When guard tone is present this audio path is muted.

Note 13. RPTR AUDIO ENABLE is high if P4-11 (CARRIER SQUELCH DETECT) AND P4-13 (PL DETECT) are unmuted and the following conditions exist: The REPEATER DISABLE switch is not in the DISABLE position, U811-3 is high, and guard tone is not present. This allows U821D to pass DETECTED AUDIO from the receiver to the exciter.

Note 14. P7-6 is normally low; P7-5 is normally floating. During battery operation, both P7-5 and P7-6 will float and an intermittent tone will be generated. If the battery voltage drops below 10.8 volts, P7-5 will go low and the tone will become constant.

Note 15. Guard Tone Bandpass Filter U835A, U835B, is a two stage filter with a Q of 45 and a 0.5 dB bandwidth of 28 Hz at 2175 Hz. This filter allows only guard tone frequencies to be passed to the guard tone detect PLL in order to prevent PLL falsing.

Note 16. The gain of U837A is controlled by U838A. When U838A-13 is low, the gain of U837A is increased by +30 dB. This allows positive detection of low level guard tone which is 30 dB below high level guard tone.

Note 17. Hysteresis Amplifier/Limiter, U837B, acts as an amplifier/hard limiter to input signals above its dead band threshold. Normally the input signal is 8 dB above the dead band threshold which allows a 6 dB day to day change in telephone line levels between the control console and the station while maintaining proper operation.

Note 18. Guard Tone Detector U815 produces a high at its Q output (U815-6) upon detection of guard tone and will remain high until guard tone ceases.

Note 19. The Delay Circuit (CR807 and U814D) compensates for slight interruptions in the output of the guard tone detector, eliminates chatter during logic level transitions, and reduces function tone decoder falsing by switching transients between high level guard tone and function tone. Turn on delay is approximately 5 msec. and turn off delay is approximately 75 msec.

Note 20. The Function Tone Window Timer flip-flop (U806A, U806C, and U814F) is set by the low output of U814D. This causes U806-6 to go high, charging the capacitor of delay circuit R875-C902 (350 msec. delay). When the threshold of U814E is reached, U814-10 goes low, resetting the function tone window.

Note 21. The output of U806B is normally low and goes high if any of its three inputs go low. With the LINE DISABLE switch (S2) off, a low from U836B-4 (guard tone detect), a low from delay circuit U814D-8, or a low from function tone timer flip-flop U806A-U806C, causes the output at U806B-9 (TRANSMIT LINE DISABLE) to go high.

Note 22. If either the LOCAL PTT switch is depressed or if MIC PTT occurs while the INTERCOM switch is in the ON position, the LINE ENABLE output at U828-6 goes high. Similarly, the RECEIVE ENABLE output at U811C-10 goes low and will remain low until the PTT signal ceases.

Note 23. Gate U823 is enabled for 350 msec. by the Function Tone Window Timer to allow line audio to pass to the function tone decoders.

Note 24. Function Tone Decoders, U816 through U820 produce a low on their output (pin 5) upon detection of their respective function tone. The low output sets a corresponding flip-flop.

Note 25. Bandwidth boost circuit (U810C and U838D) is used only when guard tone is 2100 Hz (special applications only). When used, gate U838 widens the 2050 Hz decoder bandwidth from ± 25 Hz to ± 75 Hz to assure positive 2050 Hz function tone detect.

Note 26. The Power On Reset circuit produces a low output pulse upon power turn-on. The low output sets all the bistable flip-flops to assure proper operation.

Note 27. The function tone decoder flip-flops are set and reset by a low input. For example, upon power-up, a low from Q815 through CR810 resets PL Disable Flip-Flop U829C-U829D producing a low output at U829C-10. When a 2050 Hz function tone is detected, U816-5 goes low, setting U829C-U829D, and forcing U829C-10 high. The flip-flop is reset by the presence of guard tone and either U817-5 or U818-5 going low.

Note 28. PTT Flip-Flop U840D-U840C is set whenever F1 or F2 function tone is detected. It is reset by U829-4 upon the loss guard tone detect.

Note 29. Squelch control flip-flop U825B-U825D is set (U825-4 high) by a high at U825A-1 and reset (U825-4 low) by a high at U825C-8.

Note 30. The Clock Generator Circuit (U808, U831, and U833) generates the clock frequency for the switched capacitor filters per the following table:

<u>CLOCK FREQUENCY</u>	<u>GUARD TONE FREQUENCY</u>
111.50 kHz	2100/2175 Hz
122.65 kHz	2325/2432 Hz
136.28 kHz	2700/2800 Hz

PARTS LIST

REF SYMBOL	MOTOROLA PART NO.	DESCRIPTION
		<u>CAPACITOR, fixed:</u> pF ±5%; 50 V
C800	23-11019A46	100 uF ±20%; 25 V
C801	8-11051A15	0.22 uF; 63 V
C802	21-11031A41	120 (chip)
C803	21-11032A21	.01 uF ±10% (chip)
C804	8-11051A15	0.22 uF; 63 V
C805	23-11048B11	10 uF ±20%; 35 V
C806	21-11032A21	.01 uF ±10% (chip)
C807	21-11031A39	100 (chip)
C808	21-11032A21	.01 uF ±10% (chip)
C809	23-11048B09	4.7 uF ±20%; 35 V
C810	21-11031A55	470 (chip)
C811	23-11019A46	100 uF ±20%; 25 V
C812, 813	8-11051A15	0.22 uF; 63 V
C814	21-11031A47	220 (chip)
C815	23-11019A46	100 uF ±20%; 25 V
C816	23-83210A19	500 uF +100-10%; 20 V
C817	21-11031A47	220 (chip)
C818	23-11048B09	4.7 uF ±20%; 35 V
C819	8-11051A13	0.1 uF; 63 V
C820	8-11051A15	0.22 uF 63 V
C821	21-11032A21	.01 uF ±10% (chip)
C822	8-11051A13	0.1 uF; 63 V
C823	8-11051A17	0.47 uF; 63 V
C824	21-11031A29	39 (chip)
C825	21-11031A51	330 (chip)
C826	21-11031A61	1000 (chip)
C827, 828	21-11031A29	39 (chip)
C829	8-11051A15	0.22 uF; 63 V
C830	21-11031A29	39 (chip)
C831	8-11051A13	0.1 uF; 63 V
C832	21-11031A61	.001 uF (chip) (GLN6767A only)
C833	23-82028P07	4.7 uF ±20%; 200 V
C834	21-11032A21	.01 uF ±10% (chip)
C835	8-11051A13	0.1; 63 V (GLN6768A only)
C836	8-11051A13	.01; 63 V
C837 thru 840	8-11051A13	0.1 uF; 63 V (GLN6768A only)
C841	8-11051A17	0.47 uF; 63 V (GLN6768A only)
C842	8-11051A13	0.1 uF; 63 V (GLN6768A only)
C843	8-11051A03	.0022 uF; 63 V (GLN6768A only)
C844	21-83162H36	.01 uF (GLN6768A only)
C845	23-11048B11	10 uF ±20%; 35 V
C846	21-83162H36	.01 uF
C847	8-11051A03	.0022; 63 V
C848	8-11051A13	0.1 uF; 63 V
C849	8-11051A16	0.33 uF; 63 V
C850	8-11051A13	0.1 uF; 63 V
C851	21-83162H36	.01 uF (GLN6768A only)

PARTS LIST

REF SYMBOL	MOTOROLA PART NO.	DESCRIPTION
C852	8-11051A03	.0022 uF; 63 V (GLN6768A only)
C853	8-11051A13	0.1 uF; 63 V (GLN6768A only)
C854	8-11051A16	0.33 uF; 63 V (GLN6768A only)
C855	8-11051A13	0.1 uF; 63V (GLN6768A only)
C856	21-83162A36	.01 uF (GLN6768A only)
C857	8-11051A03	.0022 uF; 63 V (GLN6768A only)
C858	8-11051A13	0.1 uF; 63 V (GLN6768A only)
C859	8-11051A16	0.33 uF; 63 V (GLN6768A only)
C860	8-11051A13	0.1 uF; 63 V (GLN6768A only)
C861	21-83162A36	.01 uF (GLN6768A only)
C862	8-11051A13	0.1 uF; 63 V (GLN6768A only)
C863	8-11051A16	0.33 uF; 63 V (GLN6768A only)
C864	8-11051A13	0.1 uF; 63 V (GLN6768A only)
C865	8-11051A03	.0022 uF; 63 V (GLN6768A only)
C866	8-11051A11	.047 uF; 63 V
C867	21-11031A61	.001 uF (chip)
C868	8-11051A16	0.33 uF; 63 V
C869	21-83162A36	.01 uF
C870	8-11051A03	.0022 uF; 63 V
C871	8-11051A13	0.1 uF; 63 V
C872	8-11051A16	0.33 uF; 63 V
C873	8-11051A13	0.1 uF; 63 V
C874	23-11019A46	100 uF \pm 20%; 25 V
C875	8-11051A15	0.22 uF; 63 V
C876, 877	21-11031A61	1000 (chip)
C878	21-11031A35	68 (chip)
C879	21-11031A15	10 \pm .5% (chip)
C880	21-11032A21	.01 uF \pm 10% (chip)
C881, 882	21-11031A61	.001 uF (chip)
C883 thru 885	21-11031A29	39 (chip)
C886	21-11031A39	100 (chip)
C887	8-811051A12	.068 uF; 63 V
C888	21-11032A21	.01 uF \pm 10% (chip)
C889	21-11031A61	.001 uF (chip)
C890	8-11051A06	.0068 uF; 63 V
C891	21-11032A21	.01 uF \pm 10% (chip)
C892	23-11048B11	10 uF \pm 20%; 35 V
C893	21-11032A21	.01 uF \pm 10% (chip)
C894	23-11019A46	100 uF \pm 20% 25 V
C895, 896	8-11051A13	0.1 uF; 63 V
C897	21-11032A21	.01 uF \pm 10% (chip)
C898	8-11051A01	.001 uF; 63 V
C899	23-11019A46	100 uF \pm 20%; 25 V
C901	21-11031A61	1000 (chip)
C902	23-11048B09	4.7 uF \pm 20%; 35 V
C903, 904	8-11051A15	0.22 uF; 63 V
C905	8-11051A13	0.1 uF; 63 V
C906	21-11032A21	.01 uF \pm 10% (chip)

PARTS LIST

REF SYMBOL	MOTOROLA PART NO.	DESCRIPTION
C907	21-11031A58	620 (chip)
C908	23-11048B06	2.2 uF ±20%
C909, 910	8-11051A15	0.22 uF; 63 V (GLN6767A only)
C911	23-11048B09	4.7 uF ±20%; 35 V (GLN6767A only)
C912	21-11031A61	1000 (chip)
C913	8-11051A15	0.22 uF; 63 V
C914	8-11051A16	0.33 uF; 63 V (GLN6767A only)
C915	23-11048B11	10 uF ±20%; 35 V (GLN6767A only)
C916	8-11051A13	0.1 uF; 63 V (GLN6767A only)
C917 thru 924	21-11032A21	.01 uF ±10% (chip) (GLN6767A only)
C940	23-11048B09	4.7 uF ±20%; 35 V
C941	8-11051A15	0.22 uF; 63 V
C945	21-11031A29	39 (chip)
C946, 947	8-11051A07	.01 uF; 63 V
C950	8-11051A13	0.1 uF; 63 V
C951	21-861439	345 ±10%; 75 V
C952 thru 954	21-861439	345 ±10%; 75 V (GLN6768A only)
C955	21-11031A61	1000 (chip)
C956, 957	21-861439	345 ±10%; 75 V (GLN6767A only)
<u>DIODE: (SEE NOTE)</u>		
CR800	48-83654H01	silicon
CR801, 802	48-83654H01	silicon (GLN6767A only)
CR803 thru 814	48-83654H01	silicon
CR815	48-83654H01	silicon (GLN6768A only)
CR816	48-83654H01	silicon
CR817, 818	48-82022N05	silicon
CR819	48-83654H02	silicon
CR820	48-83654H01	silicon
CR821	48-83654H01	silicon
CR822	48-83654H01	silicon (GLN6768A only)
CR823, 824	48-83654H01	silicon
CR825	48-83654H01	silicon (GLN6767A only)
CR826	48-83654H01	silicon (GLN6768A only)
CR827	48-83654H01	silicon
CR828	48-83654H01	silicon (GLN6768A only)
CR829 thru 832	48-83654H01	silicon
<u>LIGHT EMITTING DIODE: (SEE NOTE)</u>		
DS800	48-80058K01	red
DS801	48-80058K03	yellow (GLN6768A only)
DS802	48-80058K02	green (GLN6768A only)
<u>CONNECTOR:</u>		
J3	9-80023J01	female; 6-contact
J4	28-82984N04	male; 4-contact (GLN6768A only)
J6	9-80179403	female; 11-contact (GLN6767A only)
J8, 9	9-80023J01	female; 6-contact microphone receptacle

PARTS LIST

REF SYMBOL	MOTOROLA PART NO.	DESCRIPTION
J10	9-80179H04	female; 3-contact
J11	9-80179H03	female; 11-contact
<u>JUMPER:</u>		
JU1	6-11009D23	0 ohms resistor
JU2	6-11009D23	0 ohms resistor (GLN6768A only)
JU3	6-11009D23	0 ohms resistor
JU4	6-11009D23	0 ohms resistor (GLN6768A only)
JU5 thru 13	6-11009D23	0 ohms resistor
JU14	6-11009D23	0 ohms resistor (GLN6768A only)
JU15	6-11009D23	0 ohms resistor
JU16 thru 18	6-11009D23	0 ohms resistor (GLN6768A only)
JU20	6-11009D23	0 ohms resistor (GLN6767A only)
JU21, 22	6-11009D23	0 ohms resistor
JU23, 24	6-11009D23	0 ohms resistor (GLN6767A only)
JU26	6-11009D23	0 ohms resistor
JU27, 28	6-11009D23	0 ohms resistor (GLN6768A only)
JU29	6-11009D23	0 ohms resistor
JU30 thru 37	6-11009D23	0 ohms resistor (GLN6768A only)
<u>CONNECTOR:</u>		
P1	28-82697R03	male; 4-contact
P2A, B	9-05604C06	female, socket speaker; 2-contact
P4	28-82697R14	male; 15-contact
P5	28-82697R05	male; 6-contact
P7	28-83441F08	male; 7-contact
P12	28-82697R05	male; 6-contact
<u>TRANSISTOR: (SEE NOTE)</u>		
Q801, 802	48-869787	NPN; type M9787
Q803	48-02081B30	NPN; type M1B30 (GLN6768A only)
Q804 thru 807	48-02081B30	NPN; type M1B30
Q809	48-869619	pNP; type M9619
Q810 thru 813	48-02081B30	NPN; type M1B30
Q814	48-02081B31	PNP; type M1B31
Q815	48-02081B30	NPN; type M1B30 (GLN6767A only)
Q816	48-02081B30	NPN; type M1B30
Q826 thru 829	48-02081B30	NPN; type M1B30
Q830 thru 832	48-02081B30	NPN; type M1B30 (GLN6767A only)
Q835	48-02081B30	NPN; type M1B30 (GLN6768A only)
<u>RESISTOR, fixed: ±5%, 1/8 W;</u> unless otherwise stated		
R800	6-10024A25	100
R801	6-11024A43	560
R802	6-02369M52	18k; 0.6 W
R803	6-11024A51	1.2k
R804	6-02369M52	18k; 0.6 W

PARTS LIST

REF SYMBOL	MOTOROLA PART NO.	DESCRIPTION
R805	6-11024A79	18k
R807	6-11024A73	10k
R808	6-02369M52	18k; 0.6 W
R809	6-11024A79	18k
R810	6-11024A97	100k
R811	6-11024B06	220k
R812	6-11024A97	100k
R813	6-11024A73	10k
R814	6-11024A85	33k
R815	6-11024A89	47k
R816	6-11024A97	100k
R817	6-11024A25	100
R818	18-03464A03	variable, 20k: $\pm 10\%$; 0.5 W
R819	6-11024A89	47k
R820	18-03464A04	variable; 100k
R821	6-11024A87	39k
R822	6-02369M52	18k; 0.6 W
R823	6-11024A79	18k
R824	6-11024A85	33k
R825	6-11024A73	10k
R826	6-02369M73	1 meg; 0.6 W
R827	6-11024A89	47k
R828	6-11024A81	22k
R829	6-11024A77	15k
R830	6-11024A97	100k
R831	18-03464A04	variable; 100k
R832	6-11024B02	150k
R833	6-11024A89	47k
R834	6-11024A73	10k
R835	6-11024A79	18k
R836	6-11024A73	10k
R837	6-11024A65	4.7k
R838	6-11024A53	1.5k
R839	6-11024A73	10k
R840	6-02369M06	2.7; 0.6 W
R841	6-11024B06	220k
R842	6-11024A87	39k
R843	6-11024A81	22k
R844	6-11024A89	47k
R845	6-11024B02	150k
R846, 847	6-11024A89	47k
R848	6-11024A65	4.7k
R849	6-11024A63	3.9k
R850	6-11024A61	3.3k
R851	6-11024A65	4.7k
R852	6-02369M25	100
R853	6-11024A65	4.7k
R854, 855	6-11049D81	84.5k $\pm 1\%$; 1/4 W

PARTS LIST

REF SYMBOL	MOTOROLA PART NO.	DESCRIPTION
R856	6-11024A65	4.7k (GLN6768A only)
R857, 858	6-11024A89	47k
R859	6-11024A65	4.7k
R860	6-11024A51	1.2k
R861	6-11024A5t5	1.8k
R862	6-11009A44	620; 1/4 W
R863	6-11024B12	390k (GLN6767A only)
R864	6-02369M25	100; 0.6 W
R865	6-11024A73	10k
R866	6-11024B14	470k
R867	6-02366M84	30k $\pm 1\%$; 0.39 W
R868	18-03464A03	variable; 20k
R869	17-02254M67	3.3 meg; 125 W
R870	6-11024A73	10k
R871	6-11024A81	22k
R872	6-11024B06	220k
R873	6-11024A81	22k
R874	6-11024A56	2k
R875	6-11024A94	75k
R876	17-02254M66	2.7 meg; 125 W
R877	6-11024B14	470k (GLN6768A only)
R878	6-02366M88	43k $\pm 1\%$; 0.39 W
R879	18-83452F14	variable, 10k $\pm 10\%$; 1/2 W
R880	6-124B38	4.7 meg, 1/4 W (GLN6768A only)
R881	6-11024A73	10k
R882	6-11024A89	47k
R883	6-11024A53	1.5k (GLN6768A only)
R884, 885	6-11024B12	390k
R886	6-02369M57	47k; 0.6 W
R887	6-11024A89	47k
R888	6-11024A56	2k
R889	6-11024A97	100k
R890	6-11024B12	390k (GLN6768A only)
R891	6-11024A79	18k
R892	6-11024A89	47k (GLN6768A only)
R893	6-11024A89	47k (GLN6768A only)
R894	6-11024A89	47k (GLN6768A only)
R895	6-11024A89	47k
R896	6-11024A73	10k
R897	6-11024B14	470k
R898	6-02366M88	43k $\pm 1\%$; 0.39 W
R899	18-03464A03	variable; 20k $\pm 10\%$; 0.5 W
R900	6-11024B22	1 meg
R901	6-11024B14	470k (GLN6768A only)
R902	6-02366M88	43k $\pm 1\%$; 0.39 W (GLN6768A only)
R903	18-03464A03	variable, 20k $\pm 10\%$; 1/2 W (GLN6768A only)
R904	6-11024B22	1 meg; 1/4 W (GLN6768A only)

PARTS LIST

REF SYMBOL	MOTOROLA PART NO.	DESCRIPTION
R905	6-11024A73	10k (GLN6768A only)
R906	6-11024B14	470k (GLN6768A only)
R907	6-02366M91	56k, $\pm 1\%$; 0.39 W (GLN6768A only)
R908	18-03464A03	variable, 20k $\pm 10\%$; 0.5 W (GLN6768A only)
R909	6-11024B22	1 meg; 1/4 W (GLN6768A only)
R910	6-11024A73	10k (GLN6768A only)
R911	6-11024B14	470k (GLN6768A only)
R912	6-02366M91	56k $\pm 1\%$; 0.39 W (GLN6768A only)
R913	18-03464M03	variable, 20k $\pm 10\%$; 0.5 W (GLN6768A only)
R914	6-11024B22	1 meg $\pm 5\%$; 1/4 W (GLN6768A only)
R915	6-11024A73	10k
R916	6-11024A79	18k
R917	6-11024A77	15k
R918	6-11024A93	68k
R920	6-11024B12	390k
R921	6-02369M52	18k; 0.6 W (GLN6768A only)
R922	6-02369M61	100k; 0.6 W
R923	6-02369M58	56k; 0.6 W
R924	6-02369M54	27k; 0.6 W
R925	6-11024A89	47k
R926	6-02366M74	11k $\pm 1\%$; 0.39 W
R927	6-02366M93	68k $\pm 1\%$; 0.39 W
R928	6-02366M76	13k $\pm 1\%$; 0.39 W
R929	6-02366M77	15k $\pm 1\%$; 0.39 W
R930	6-02366M78	16k $\pm 1\%$; 0.39 W
R931	18-03464A01	variable, 2k $\pm 10\%$; 0.5 W
R932	6-02369M52	18k ± 0.6 W
R933	6-11024A79	18k
R934	6-11024A73	10k
R935	6-11024A65	4.7k
R936	6-11024B06	220k
R937	6-11024A73	10k (GLN6768A only)
R938	6-11024B79	18k
R939	6-11024A77	15k
R940, 941	6-11024A73	10k
R942	6-11024A65	4.7k
R944	6-02369M52	18k; 0.6 W
R945	6-11024A56	2k
R946	6-11024A73	10k
R947	6-11024B06	220k
R948	6-11024A89	47k
R949	6-11024B06	220k
R950	6-11024!89	47k
R951	6-11024A97	100k
R952	6-11024A73	10k
R953	6-11024A89	47k

PARTS LIST

REF SYMBOL	MOTOROLA PART NO.	DESCRIPTION
R954	6-11024A97	100k
R955	6-11024B06	220k
R956	6-11024A73	10k
R958	6-11049D06	14k $\pm 1\%$; 0.39 W
R959	6-02366M05	150k $\pm 1\%$; 0.39 W
R960	6-02366M77	15k $\pm 1\%$; 0.39 W
R961	6-02366M77	15k $\pm 1\%$; 0.39 W
R962	6-02366M78	16k $\pm 1\%$; 0.39 W
R963	18-03464A01	variable, 2k $\pm 10\%$; 0.5 W
R964	6-11024A65	4.7k
R965	6-11024A35	270
R966	6-11024A89	39k
R967	6-02366M77	15k $\pm 1\%$; 0.39 W
R968	18-03464A01	variable, 2k $\pm 10\%$; 0.5 W
R969	6-02366M78	16k $\pm 1\%$; 0.39 W
R970	6-02367M16	430k $\pm 1\%$; 0.39 W
R971	6-11024B06	220k
R972	18-03464A01	variable, 2k $\pm 10\%$; 0.5 W
R973	6-02366M77	15k $\pm 1\%$; 0.39 W
R974	6-02366M78	16k $\pm 1\%$; 0.39 W
R975	6-02367M16	430k $\pm 1\%$; 0.39 W
R9076, 977	6-11024A73	10k
R978	6-11024A89	47k
R979	6-11024A92	62k
R980	6-11024A73	10k
R981	6-11024A65	4.7k
R982	6-10621C18	1740 $\pm 1\%$; 1/4 W
R983	6-10621CD28	2210 $\pm 1\%$; 1/4 W
R984	6-11024A73	10k
R985, 986	6-11024A45	680
R987	6-02379M31	330; 0.6 W
R988, 989	6-11024A89	47k
R990	6-11024A59	2.7k
R991	6-11024A79	18k
R992	6-11024A79	18k
R993	6-11024A85	33k
R994	6-11024A73	10k
R995	6-11024A77	15k
R996	6-11024A64	4.3k
R997	6-11024A79	18k
R998	6-11024A89	47k
R1000	6-11024A85	33k
R1001	6-11024A77	15k
R1002	18-03464A04	variable, 100k $\pm 10\%$; 0.5 W
R1003, 1004	6-11024A57	2.2k
R1005	6-11024A89	47k
R1006	6-11024A89	47k (GLN6768A only)
R1007	6-11024A73	10k

PARTS LIST

REF SYMBOL	MOTOROLA PART NO.	DESCRIPTION
R1008, 1009	6-02369M57	47k; 0.6 W
R1010, 1011	6-11024A89	47k
R1012	6-11024A53	1.5k
R1013	6-11024A89	47k
R1014, 1015	6-11024A79	18k
R1016	6-11024A63	3.9k
R1017	6-11024A71	8.2k
R1018	6-11024A61	2.7k
R1019	6-11024A79	18k
R1020	6-11024A73	10k
R1021	6-11024A75	12k
R1022	6-11024A65	4.7k
R1023 thru 1025	6-11024A73	10k
R1026	6-11024A89	47k
R1027	6-11024A81	22k
R1028	6-11024A89	47k
R1029	6-11024A89	47k (GLN6768A only)
R1030	6-11024A75	12k
R1031	6-11024B06	220k
R1032	6-11024B02	150k
R1033	6-11024A59	2.7k
R1037	6-11024A56	2k
R1038	6-11024A55	1.8k
R1041	6-02366M77	15k $\pm 1\%$; 0.39 W
R1042	6-02369M30	270
R1043	6-11024A65	4.7k
R1045	6-11024B14	470k (GLN6768A only)
R1046	6-11024A73	10k
R1047	6-11024A79	18k
R1048	6-11024A89	47k (GLN6768A only)
R1049	6-11024A89	47k (GLN6768A only)
R1050	6-11024A89	47k
R1051	6-11024A89	47k (GLN6768A only)
R1053	6-11024A79	18k
R1054	6-11024A71	8.2k
R1055	6-11024A65	4.7
R1056	6-11024A96	91k
R1057	6-11024A89	47k
R1058	6-11024B14	470k
R1059	6-11024A57	2.2k
R1060	6-11024A89	47k
R1061	6-02369M51	15k; 0.6 W
R1062	6-11024A89	47k
R1063	6-11024A73	10k
R1064 thru 1068	6-11024A89	47k
R1069	6-02366M70	7.5k $\pm 1\%$; 0.39 W
R1070	6-11024A65	4.7k
R1072	6-11024A73	10k

PARTS LIST

REF SYMBOL	MOTOROLA PART NO.	DESCRIPTION
R1073	6-11024A89	47k
R1074	6-11024A65	4.7k
R1079 thru 1083	6-11024A89	47k
R1084	6-11024A73	10k
R1085	6-02369M57	47k; 0.6 W
R1086	6-02369M49	10k; 0.6 W
R1087	6-02366M77	15k \pm 1%; 0.39 W
R1088	6-11024A25	100
R1089	6-11024A65	4.7k
R1090	6-11024A73	10k
R1091	6-11024A73	10k
R1092	6-11024A89	47k
R1093	6-11024A73	10k
R1094	6-11024A65	4.7k
R1095	6-11024A81	22k
R1096 thru 1098	6-11024A89	47k
R1099	6-11024A81	22k
R1100 thru 1104	6-11024A81	22k
R1105	6-11024B89	47k
R1106	6-11024A25	100
R1107	6-11024A89	47k
R1108	6-11024A81	22k
R1109	6-11024A81	22k
R1110	6-11024A53	1.5k
R1111	6-11024A73	10k
R1113	6-11024A89	47k
R1114	6-11024A73	10k
R1115	6-11024A73	10k
R1116	6-11024A79	18k
R1117 thru R1121	6-11024A73	10k
R1122	6-11024A53	1.5k
R1123	6-11024A73	10k
R1300, 1301	6-11024A73	10k
R1302	6-11024A79	18k
R1310	6-11049D04	13.3k \pm 1%; 1/4 W
R1311	6-11009A89	47k; 1.4 W
SWITCH:		
S810, 802	40-03445A01	slide, 300 ma; 24 V
S803	40-03429A01	miniature momentary
S804, 805	40-03445A01	slide, 300 ma; 24 V
S806	40-03445A01	slide, 300 ma; 24 V

PARTS LIST

REF SYMBOL	MOTOROLA PART NO.	DESCRIPTION
T800	25-83036L01	<u>TRANSFORMER:</u> leads 1 and 2; 25 ohms, 3 and 4; 25 ohms leads 7 and 9; 250 ohms, 11 and 12; 250 ohms
T801	25-84007C02	pri: 10k res. sec: 10k res.
TP00 thru 6	28-02002M15	<u>TEST POINTS:</u> plug connector
TP7	28-02002M16	plug connector
TP8	28-02002M15	plug connector
TP13	28-02002M16	plug connector
TP14	28-02002M15	plug connector
TP16 thru 19	28-02002M15	plug connector
TP20	28-02002M15	plug connector
TP22, 23	28-02002M15	plug connector
TP25 thru 31	28-02002M15	plug connector
TP34, 35	28-02002M15	plug connector
U800 thru 802	51-83629M18	<u>INTEGRATED CIRCUIT:</u> (SEE NOTE) quad operational amplifier
U803	51-83629M22	operational amplifier
U804	51-82884L05	quad 2-input NAND gate
U806	51-82884L06	triple 3-input NAND gate
U807, 808	51-82884L05	quad 2-input NAND gate
U809	51-84371K94	quad 2-input OR gate
U810	51-82884L51	quad 2-input AND gate
U811	51-84887K28	triple 3-input AND gate
U812	51-82884L02	hex inverting buffer
U814	51-83627M92	hex trigger SWchmitt
U815	51-83629M70	PLL monolithic
U816	51-83629M70	PLL monolithic (GLN6768A only)
U817	51-83629M70	PLL monolithic
U818	51-83629M70	PLL monolithic (GLN6768A only)
U819	51-83629M70	PLL monolithic (GLN6768A only)
U820	51-83629M70	PLL monolithic (GLN6768A only)
U821 thru 823	51-82884L14	quad bilateral switch
U824	51-83629M18	quad operational amplifier
U825	51-82884L05	quad 2-input NAND gate
U826	51-82884L51	quad 2-input AND gate
U828	51-82884L64	triple 3-input OR gate
U829	51-82884L05	quad 2-input NAND gate
U831	51-03386A03	J-K flip flop
U832	51-82884L04	quad 2-input NOR gate
U833	51-03386A02	counter 4-bit binary w/clear
U834, 835	51-83629M76	dual switched capacitor filter
U836	51-82884L05	quad 2-input NAND gate

PARTS LIST

REF SYMBOL	MOTOROLA PART NO.	DESCRIPTION
U837	51-83629M18	quad operational amplifier
U838	51-82884L14	quad bilateral switch
U839	51-82609M33	dual operational amplifier
VR800	48-83461E40	<u>VOLTAGE REGULATOR:</u> (SEE NOTE) Zener type; 5.1 V
Y801	48-82611M15	<u>CRYSTAL:</u> 4.9068 MHz

NOTE: For optimum performance, diodes, transistors, crystals and integrated circuits must be ordered by Motorola part numbers.

PARTS LIST

REF SYMBOL	MOTOROLA PART NO.	DESCRIPTION
		<u>CAPACITOR, fixed:</u> pF ±5%; 50 V
C800	23-11019A46	100 uF ±20%; 25 V
C801	8-11051A15	0.22 uF; 63 V
C805	23-11048B11	10 uF ±20%; 35 V
C806	21-11032A21	.01 uF ±10% (chip)
C807	21-11031A39	100 (chip)
C810	21-11031A55	470 (chip)
C812, 813	8-11051A15	0.22 uF; 63 V
C814	21-11031A47	220 (chip)
C815	23-11019A46	100 uF ±20%; 25 V
C816	23-83210A19	500 uF +100-10%; 20 V
C817	21-11031A47	220 (chip)
C818	23-11048B09	4.7 uF ±20%; 35 V
C819	8-11051A13	0.1 uF; 63 V
C820	8-11051A15	0.22 uF 63 V
C822	8-11051A13	0.1 uF; 63 V
C887	8-811051A12	.068 uF; 63 V
C888	21-11032A21	.01 uF ±10% (chip)
C889	21-11031A61	.001 uF (chip)
C890	8-11051A06	.0068 uF; 63 V
C891	21-11032A21	.01 uF ±10% (chip)
C892	23-11048B11	10 uF ±20%; 35 V
C893	21-11032A21	.01 uF ±10% (chip)
C898	8-11051A01	.001 uF; 63 V
C899	23-11019A46	100 uF ±20%; 25 V
C908	23-11048B06	2.2 uF ±20%
C915	23-11048B11	10 uF ±20%; 35 V (GLN6767A only)
C916	8-11051A13	0.1 uF; 63 V (GLN6767A only)
C945	21-11031A29	39 (chip)
C946, 947	8-11051A07	.01 uF; 63 V
		<u>DIODE:</u> (SEE NOTE)
CR800	48-83654H01	silicon
CR803, 804	48-83654H01	silicon
CR825	48-83654H01	silicon (GLN6767A only)
CR827	48-83654H01	silicon
CR829	48-83654H01	silicon
CR832	48-83654H01	silicon
		<u>LIGHT EMITTING DIODE:</u> (SEE NOTE)
DS800	48-80058K01	red
		<u>CONNECTOR:</u>
J3	9-80023J01	female; 6-contact
J6	9-80179H03	female; 11-contact
J8, 9	9-80023J01	female; 6-contact microphone receptacle

PARTS LIST

REF SYMBOL	MOTOROLA PART NO.	DESCRIPTION
		<u>JUMPER:</u>
JU12	6-11009D23	0 ohms resistor
JU22	6-11009D23	0 ohms resistor
JU26	6-11009D23	0 ohms resistor
JU29	6-11009D23	0 ohms resistor
JU12	6-11009D23	0 ohms resistor
JU131	6-11009D23	0 ohms resistor
		<u>CONNECTOR:</u>
P2A, B	9-05604C06	female, socket speaker; 2-contact
P4	28-82697R14	male; 15-contact
P5	28-82697R05	male; 6-contact
P7	28-83441F08	male; 7-contact
		<u>TRANSISTOR: (SEE NOTE)</u>
Q804 thru 807	48-02081B30	NPN; type M1B30
Q812, 813	48-02081B30	NPN; type M1B30
Q814	48-02081B31	PNP; type M1B31
Q815	48-02081B30	NPN; type M1B30
Q816	48-02081B30	NPN; type M1B30
Q828, 829	48-02081B30	NPN; type M1B30
Q830	48-02081B30	NPN; type M1B30
Q832	48-02081B30	NPN; type M1B30
		<u>RESISTOR, fixed: ±5%, 1/8 W;</u> unless otherwise stated
R800	6-10024A25	100
R801	6-11024A43	560
R804	6-02369M52	18k; 0.6 W
R805	6-11024A79	18k
R807	6-11024A73	10k
R808	6-02369M52	18k; 0.6 W
R809	6-11024A79	18k
R810	6-11024A97	100k
R812	6-11024A97	100k
R813	6-11024A73	10k
R814	6-11024A85	33k
R815	6-11024A89	47k
R816	6-11024A97	100k
R817	6-11024A25	100
R818	18-03464A03	variable, 20k: ±10%; 0.5 W
R819	6-11024A89	47k
R820	18-03464A04	variable; 100k
R822	6-02369M52	18k; 0.6 W
R824	6-11024A85	33k
R825	6-11024A73	10k
R833	6-11024A89	47k
R835	6-11024A79	18k
R836	6-11024A73	10k

PARTS LIST

REF SYMBOL	MOTOROLA PART NO.	DESCRIPTION
R838	6-11024A53	1.5k
R839	6-11024A73	10k
R840	6-02369M06	2.7; 0.6 W
R842	6-11024A87	39k
R843	6-11024A81	22k
R844	6-11024A89	47k
R845	6-11024B02	150k
R870	6-11024A73	10k
R871	6-11024A81	22k
R872	6-11024B06	220k
R874	6-11024A56	2k
R875	6-11024A94	75k
R881	6-11024A73	10k
R882	6-11024A89	47k
R888	6-11024A56	2k
R889	6-11024A97	100k
R915	6-11024A73	10k
R922	6-02369M61	100k; 0.6 W
R923	6-02369M58	56k; 0.6 W
R924	6-02369M54	27k; 0.6 W
R925	6-11024A89	47k
R934	6-11024A73	10k
R937	6-11024A73	10k
R940, 941	6-11024A73	10k
R945	6-11024A56	2k
R946	6-11024A73	10k
R947	6-11024B06	220k
R948	6-11024A89	47k
R949	6-11024B06	220k
R950	6-11024A89	47k
R951	6-11024A97	100k
R952	6-11024A73	10k
R953	6-11024A89	47k
R954	6-11024A97	100k
R955	6-11024B06	220k
R956	6-11024A73	10k
R9076, 977	6-11024A73	10k
R978	6-11024A89	47k
R980	6-11024A73	10k
R981	6-11024A65	4.7k
R991	6-11024A79	18k
R992	6-11024A79	18k
R993	6-11024A85	33k
R994	6-11024A73	10k
R997	6-11024A79	18k
R998	6-11024A89	47k
R1000	6-11024A85	33k
R1005	6-11024A89	47k

PARTS LIST

REF SYMBOL	MOTOROLA PART NO.	DESCRIPTION
R1007	6-11024A73	10k
R1008, 1009	6-02369M57	47k; 0.6 W
R1010, 1011	6-11024A89	47k
R1012	6-11024A53	1.5k
R1013	6-11024A89	47k
R1014, 1015	6-11024A79	18k
R1017	6-11024A71	8.2k
R1026	6-11024A89	47k
R1028	6-11024A89	47k
R1037	6-11024A56	2k
R1045	6-11024B14	470k
R1046	6-11024A73	10k
R1050	6-11024A89	47k
R1055	6-11024A65	4.7k
R1056	6-11024A96	91k
R1057	6-11024A89	47k
R1059	6-11024A57	2.2k
R1060	6-11024A89	47k
R1061	6-02369M51	15k; 0.6 W
R1062	6-11024A89	47k
R1063	6-11024A73	10k
R1064 thru 1068	6-11024A89	47k
R1072	6-11024A73	10k
R1074	6-11024A65	4.7k
R1084	6-11024A73	10k
R1085	6-02369M57	47k; 0.6 W
R1086	6-02369M49	10k; 0.6 W
R1088	6-11024A25	100
R1093	6-11024A73	10k
R1095	6-11024A81	22k
R1096 thru 1097	6-11024A89	47k
R1099	6-11024A81	22k
R1100 thru 1104	6-11024A81	22k
R1106	6-11024A25	100
R1107	6-11024A89	47k
R1108	6-11024A81	22k
R1109	6-11024A81	22k
R1110	6-11024A53	1.5k
R1111	6-11024A73	10k
R1113	6-11024A89	47k
R1114	6-11024A73	10k
R1115	6-11024A73	10k
R1116	6-11024A79	18k
R1117 thru R1121	6-11024A73	10k
R1122	6-11024A53	1.5k
R1123	6-11024A73	10k

PARTS LIST

REF SYMBOL	MOTOROLA PART NO.	DESCRIPTION
S801, 802	40-03445A01	<u>SWITCH:</u> slide, 300 ma; 24 V
S803	40-03429A01	miniature momentary
S806	40-03445A01	slide, 300 ma; 24 V
TPO, 01, GNP	28-02002M15	<u>TEST POINTS:</u> plug connector
U800 thru 802	51-83629M18	<u>INTEGRATED CIRCUIT:</u> (SEE NOTE) quad operational amplifier
U803	51-83629M22	operational amplifier
U809	51-84371K94	quad 2-input OR gate
U811	51-84887K28	triple 3-input AND gate
U812	51-82884L02	hex inverting buffer
U814	51-83627M92	hex trigger Schmitt
U821 thru 823	51-82884L14	quad bilateral switch
U824	51-83629M18	quad operational amplifier
U825	51-82884L05	quad 2-input NAND gate
U826	51-82884L51	quad 2-input AND gate
U827	51-84371K76	dual timer
U828	51-82884L64	triple 3-input OR gate
U829	51-82884L05	quad 2-input NAND gate
U832	51-82884L04	quad 2-input NOR gate
U839	51-82609M33	dual operational amplifier

NOTE: For optimum performance, diodes, transistors, crystals and integrated circuits must be ordered by Motorola part numbers.

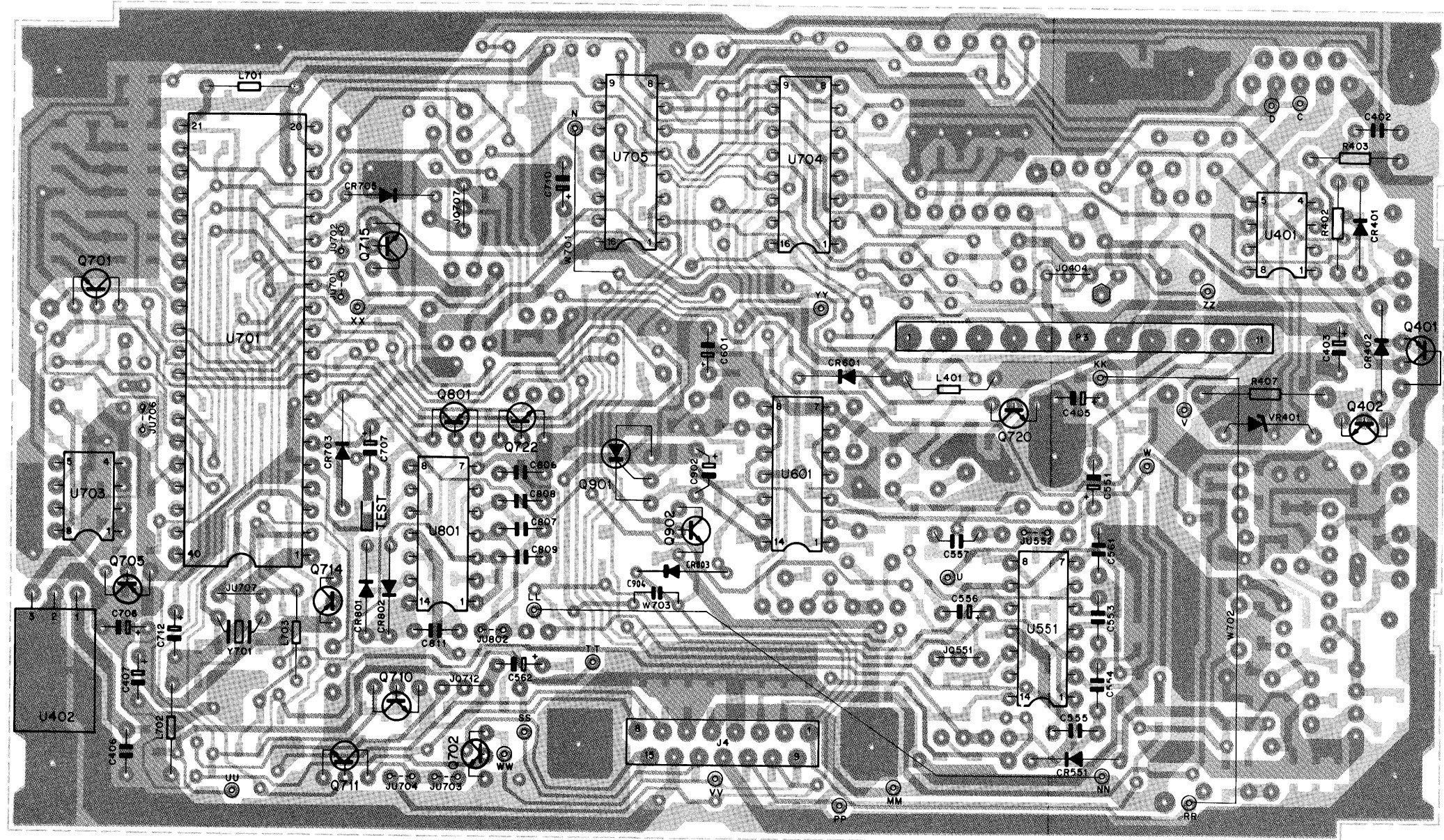

COMPONENT SIDE @ DEPS-43329-A
 SOLDER SIDE @ DEPS-43330-A (REV)
 COMPONENT OVERLAY @ DEPS-43333-A

SHOWN FROM COMPONENT SIDE

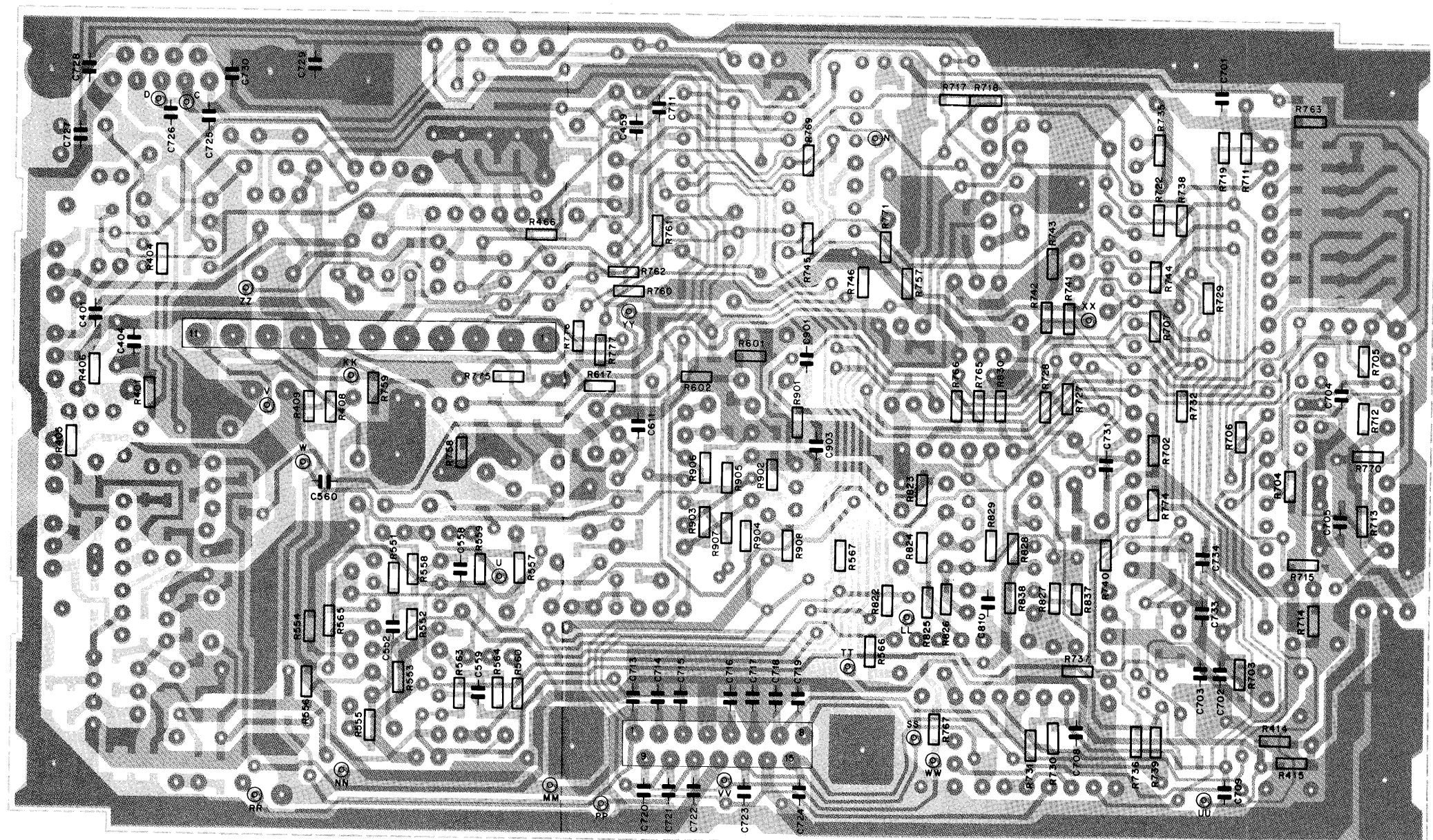

COMPONENT SIDE @ DEPS-43329-A (REV)
 SOLDER SIDE @ DEPS-43330-A
 CHIP COMPONENT OVERLAY DEPS-43334

SHOWN FROM SOLDER SIDE

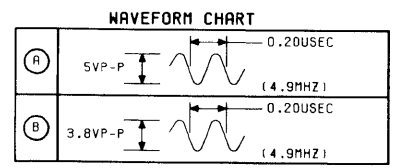
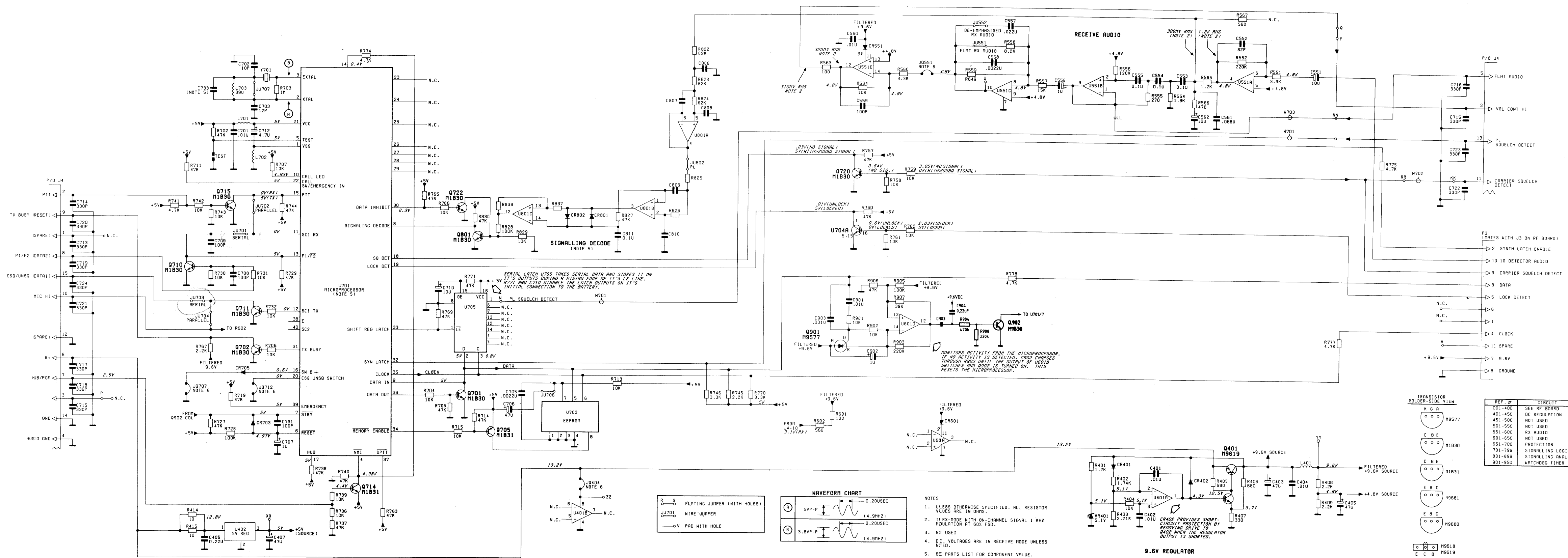

- NOTES:**
1. UNLESS OTHERWISE SPECIFIED, ALL RESISTOR VALUES ARE IN OHMS.
 2. IF RX-MODE WITH ON-CHANNEL SIGNAL 1 KHZ MODULATION AT 50% PSD.
 3. NOT USED.
 4. DC VOLTAGES ARE IN RECEIVE MODE UNLESS NOTED.
 5. SEE PARTS LIST FOR COMPONENT VALUE.
 6. J5 JUMPER FROM COLLECTOR TO EMITTER OF REMOVED TRANSISTOR.

TRANSISTOR SOLDER-SIDE VIEW

REF. #	CIRCUIT
001-400	SEE RF BOARD
401-450	DC REGULATION
451-500	NOT USED
501-550	NOT USED
551-600	RX AUDIO
601-650	NOT USED
651-700	PROTECTION
701-799	SIGNALING LOGIC
801-899	SIGNALING ANALOG
901-950	WATCHDOG TIMER

PARTS LIST

REF SYMBOL	MOTOROLA PART NO.	DESCRIPTION
		<u>CAPACITOR, fixed:</u> uF $\pm 5\%$; 50 V unless otherwise stated
C401	21-11032A21	.01 $\pm 10\%$
C402	8-11051A07	.01, 63 V
C403	23-11048B19	47 $\pm 20\%$; 16 V, electrolytic
C404	21-11032A21	.01 $\pm 10\%$
C405	23-11048B19	47 $\pm 20\%$; 16 V, electrolytic
C406	8-11051A15	.22, 63 V
C407	23-84538G29	47 $\pm 20\%$; 10 V, tantalum
C551	23-11048B13	10 $\pm 20\%$, 16 V electrolytic
C552	21-11031A37	82 pF
C553 thru 555	8-11051A13	.1, 63 V
C556	23-11048B05	1 $\pm 20\%$, electrolytic
C557	8-11051A09	.022, 63 V
C558	21-11032A13	.0022 $\pm 10\%$
C559	21-11031A39	100 pF
C560	21-11032A21	.01 $\pm 10\%$
C561	8-11051A12	.068, 63 V
C562	23-11048B13	10 $\pm 20\%$, 16 V, electrolytic
C601	23-11048B19	47 $\pm 20\%$, 16 V, electrolytic
C701	21-11032A21	.01 $\pm 10\%$
C702	21-11031A15	10 pF $\pm .5$ pF
C703	21-11031A17	12 pF
C704, 705	21-11032A13	.0022 $\pm 10\%$
C706	23-11048B19	47 $\pm 20\%$, 16 V, electrolytic
C707	23-11048B05	1 $\pm 20\%$, electrolytic
C708, 709	21-11031A39	100 pF
C710	23-11048B13	10 $\pm 20\%$, 16 V, electrolytic
C712	23-84538G02	4.7 $\pm 20\%$, 20 V, tantalum
C713 thru 724	21-11031A51	330 pF
C731	21-11031A39	100 pF
C733	21-11031A19	15 pF
C806	8-11051A10	.033, 63 V
C807	8-11051A12	.068, 63 V
C808	8-11051A04	.0033, 63 V
C809	8-11051A13	.1, 63 V
C810	21-11031A63	1200 pF
C811	8-11051A13	.1, 63 V
C901	21-11032A21	.01 $\pm 10\%$
C902	23-11048B05	1 $\pm 20\%$, electrolytic
C903	21-11031A61	.001
		<u>DIODE:</u> (SEE NOTE)
CR401	48-83654H02	silicon
CR402, 403	48-83654H01	silicon
CR551	48-83654H01	silicon
CR601	48-83654H01	silicon
CR703	48-82178A06	germanium, 30 V

PARTS LIST

REF SYMBOL	MOTOROLA PART NO.	DESCRIPTION
CR705	48-83654H01	silicon
CR801, 802	48-83654H01	silicon
<u>CONNECTOR, receptacle:</u>		
J4	9-80059K01	9-pin subminiature D connector
J5	9-80060K01	15-pin subminiature D connector
<u>JUMPERS:</u>		
JU404	6-11009F23	0 ohms resistor
JU501	6-11009F23	0 ohms resistor
JU552	6-11009F23	0 ohms resistor
JU701 thru 704	6-11009F23	0 ohms resistor
JU707	6-11009F23	0 ohms resistor
JU712	6-11009F23	0 ohms resistor
JU717	6-11009F23	0 ohms resistor
JU802	6-11009F23	0 ohms resistor
<u>COIL:</u>		
L401	24-83961B02	5 turns, green
L701, 702	24-83961B02	5 turns, green
L703	24-11047C63	39 uH
<u>CONNECTOR, plug:</u>		
P3	28-80261H01	11-pin
P6	28-80260H01	6-pin
<u>TRANSISTOR: (SEE NOTE)</u>		
Q401	48-00869619	PNP; type M9619
Q402	48-02081B30	NPN; type M1B30
Q701, 702	48-02081B30	NPN; type M1B30
Q705	48-02081B31	PNP; type M1B31
Q707, 710, 711	48-02081B30	NPN; type M1B30
Q714	48-02081B31	PNP; type M1B31
Q715	48-02081B30	NPN; type M1B30
Q720 thru 722	42-02081B30	NPN; type M1B30
Q801	48-02081B30	NPN; type M1B30
Q901	48-008695477	SCR; type M9577
Q902	48-02081B30	NPN; type M1B30
<u>RESISTOR, fixed: ±5%, 1/8 W;</u> unless otherwise stated		
R401	6-11024A51	1.2k
R402	6-10621C18	1.74k, ±1%;, 1/4 W
R403	6-10621C28	2.21k, ±1%, 1/4 W
R404	6-11024A73	10k
R405, 406	6-11024A45	680
R407	17-02280M31	330, 1/2 W, metal film
R408, 409	6-11024A57	2.2k

PARTS LIST

REF SYMBOL	MOTOROLA PART NO.	DESCRIPTION
R414, 415	6-11024A01	10
R551	6-11024A61	3.3k
R552	6-11024B06	220k
R554	6-11024A55	1.8k
R555	6-11024A35	270
R556	6-11024A99	120k
R557	6-11024A77	15k
R558	6-11024A71	8.2k
R559	6-11024A89	47k
R560	6-11024A61	3.3k
R563	6-11024A25	100
R564	6-11024A73	10k
R565	6-11024A51	1.2k
R566	6-11024A41	470
R567	6-11024A43	560
R608	6-11024A73	10k
R609	6-11024B17	620k
R702	6-11024A89	47k
R703	6-11024B22	1 meg
R704	6-11024A73	10k
R705	6-11024A89	47k
R706, 707	6-11024A73	10k
R711	6-11024A89	47k
R712, 713	6-11024A73	10k
R714	6-11024A89	47k
R715	6-11024A73	10k
R719	6-11024A89	47k
R722	6-11024A89	47k
R727	6-11024A89	47k
R728	6-11024A97	100k
R729	6-11024A89	47k
R730 thru 732	6-11024A73	10k
R736	6-11024A73	10k
R737, 738	6-11024A89	47k
R739	6-11024A73	10k
R740	6-11024A89	47k
R741	6-11024A65	4.7k
R742, 743	6-11024A73	10k
R744	6-11024A89	47k
R745	6-11024A57	2.2k
R746	6-11024A61	3.3k
R757	6-11024A89	47k
R758, 7559	6-11024A73	10k
R760	6-11024A89	47k
R761, 762	6-11024A73	10k
R763	6-11024A89	47k
R765	6-11024A89	47k
R766	6-11024A73	10k

PARTS LIST

REF SYMBOL	MOTOROLA PART NO.	DESCRIPTION
R767	6-11024A57	2.2k
R768	6-11024A73	10k
R769	6-11024A89	47k
R770	6-11024A61	3.3k
R771	6-11024A89	47k
R774 thru 777	6-11024A65	4.7k
R822 thru 824	6-11024A92	62k
R825, 826	6-11024A92	62k
R827	6-11024A89	47k
R828	6-11024A97	100k
R829	6-11024A73	10k
R830	6-11024A89	47k
R837	6-11024B23	0 (jumper)
R901	6-11024A73	10k
R902	6-11024A73	10k
R903	6-11024B06	220k
R904, 905	6-11024A97	100k
R906	6-11024A89	47k
R907	6-11024A87	39k
R908	6-11024A73	10k
<u>INTEGRATED CIRCUIT:</u> (SEE NOTE)		
U401	51-82609M33	dual op amp
U402	51-80068C06	5 V regulator
U551	51-83629M06	quad op amp
U601	51-83629M06	quad op amp
U701	51-97018C01	custom microcomputer
	of	
	51-97018C03	custom microcomputer
U704	51-84320A32	20A32 driver
U705	51-83627M42	serial latch
U801	51-83629M06	quad op amp
<u>VOLTAGE REGULATOR:</u> (SEE NOTE)		
VR 401	48-83461E40	Zener, 5.1 V
<u>CRYSTAL:</u> (SEE NOTE)		
Y701	48-80173D08	quartz, 4.9248 MHz

PARTS LIST

REF SYMBOL	MOTOROLA PART NO.	DESCRIPTION
		<u>MECHANICAL PARTS:</u>
	3-80269H01	SCREW, tap-tie (2.5 mm); 4 used
	9-80269B04	SOCKET, IC
	9-80269B08	SOCKET IC; 2 used
	14-80066K01	INSULATOR, audio regulator
	14-80067K01	INSULATOR, connector
	26-80212H01	HEAT SINK, power

NOTE: For optimum performance, diodes, transistors, crystals and integrated circuits must be ordered by Motorola part numbers.

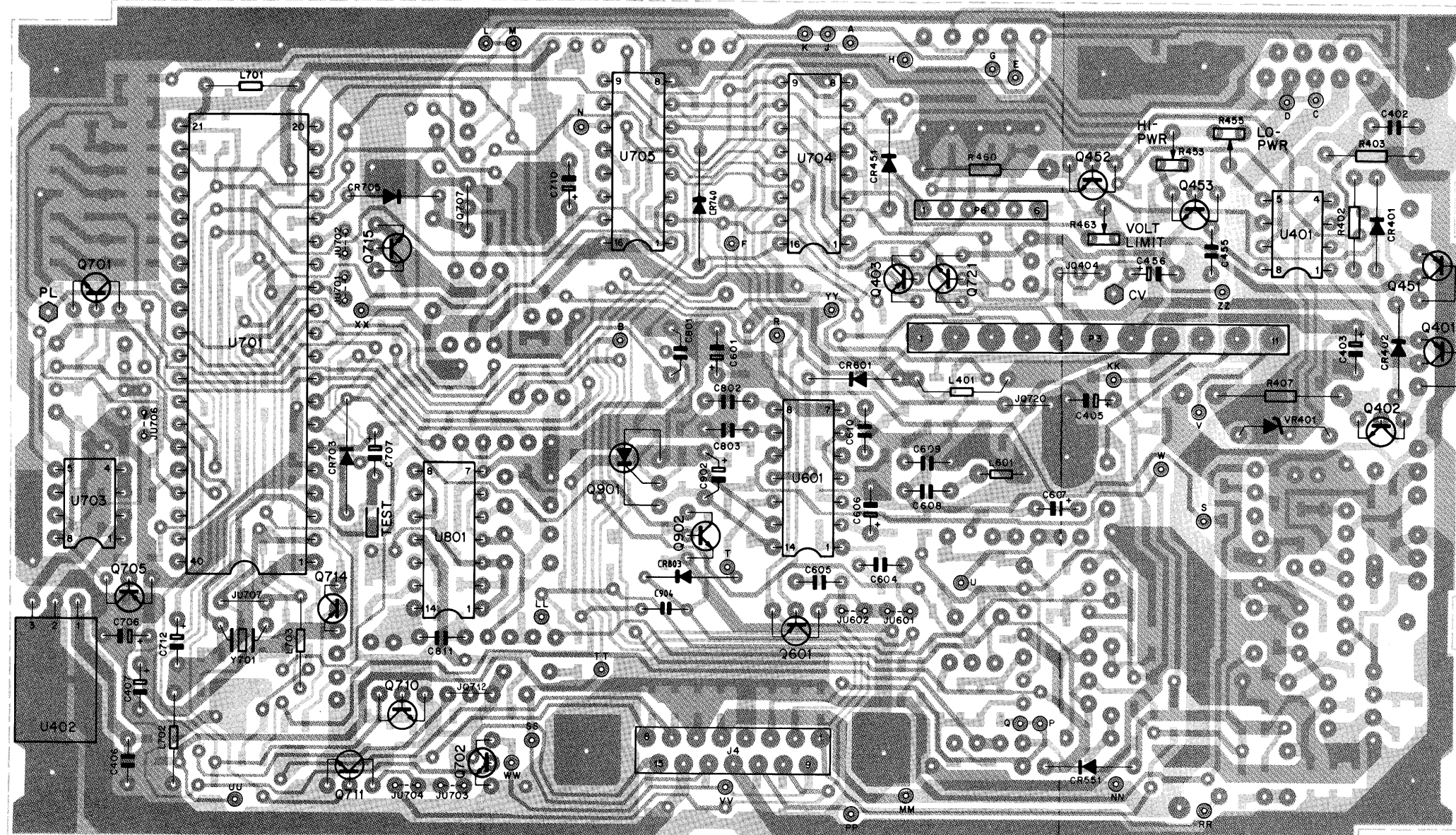

COMPONENT SIDE ● DEPS-43329-A
 SOLDER SIDE ● DEPS-43330-A (REV.)
 COMPONENT OVERLAY ● DEPS-43335-A

SHOWN FROM COMPONENT SIDE

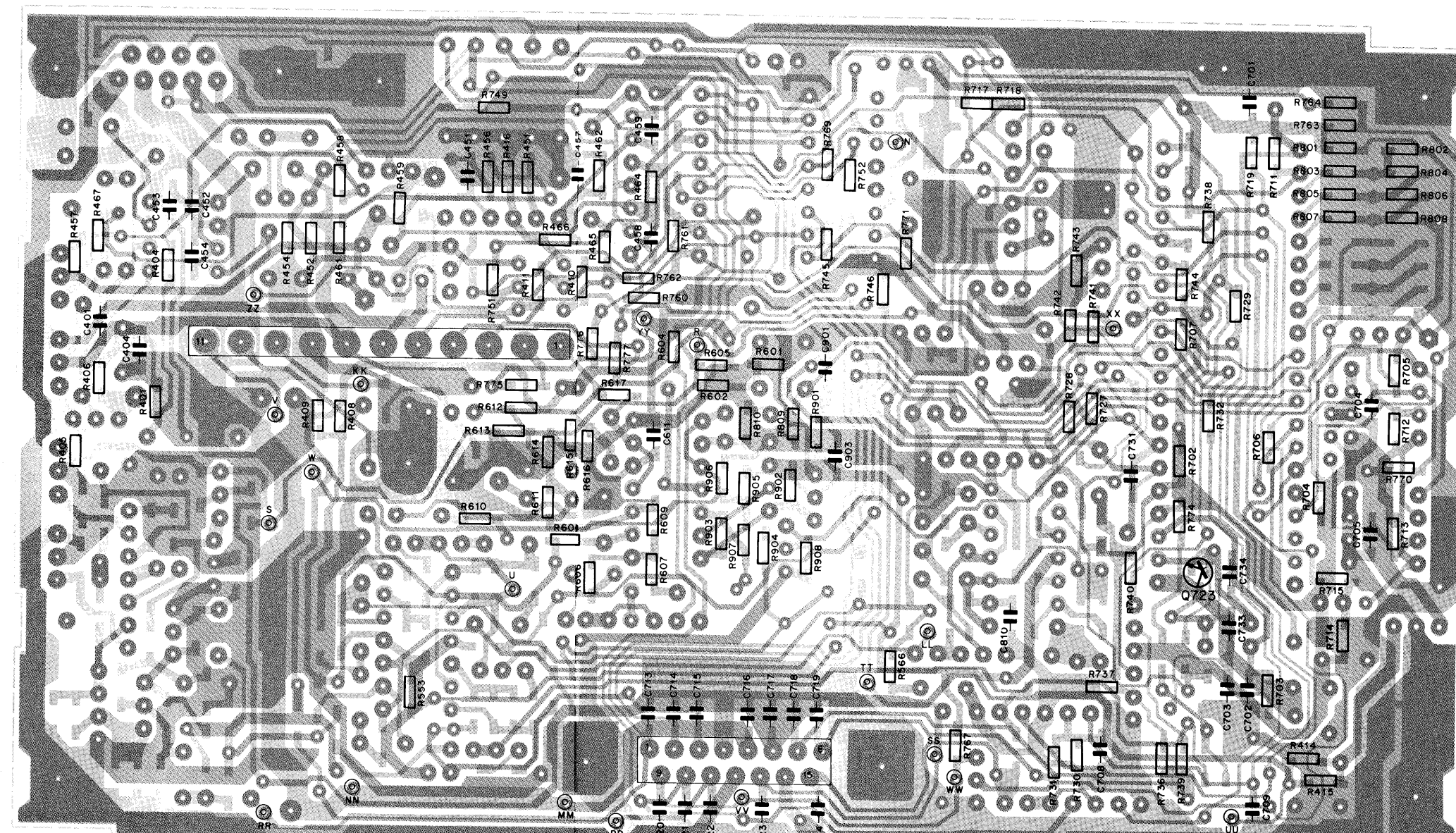

COMPONENT SIDE ● DEPS-43329-A (REV.)
 SOLDER SIDE ● DEPS-43330-A
 CHIP COMPONENT OVERLAY ● DEPS-43336

SHOWN FROM SOLDER SIDE

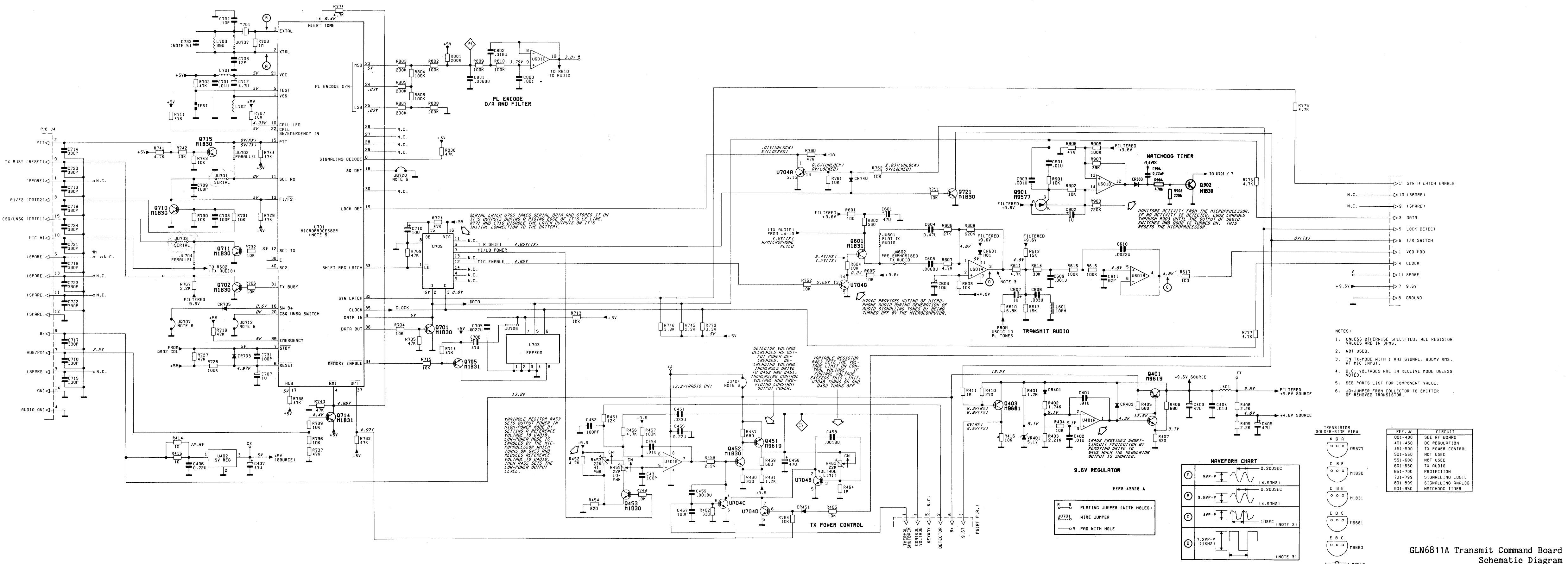

GLN6811A Transmit Command Board
Schematic Diagram
Motorola No. 32-SP3760001-1
(Sheet 2 of 2)
3/30/87

PARTS LIST

REF SYMBOL	MOTOROLA PART NO.	DESCRIPTION
		<u>CAPACITOR, fixed:</u> chip, uF ±5%; 50 V unless otherwise stated
C401	21-11032A21	.01, 10%
C402	8-11051A07	Mtlz Polyest .01 63 V
C403	23-11048B19	Alu 47 20%, 16V
C404	21-11032A21	.01, 10%
C405	23-11048B19	Alu 47 20%; 16 V
C406	8-11051A15	Mtlz Polyest .22; 63 V
C407	23-84538G29	Tant 47 20%; 10 V
C451	21-11032A27	.033; 10%
C452, 453	21-11031A39	100 pF
C454	21-11032A21	.01; 10%
C455	8-11051A15	Mtlz Polyest .22; 63 V
C456	23-11048B19	Alu 47 20%; 16 V
C457	21-11031A39	100 pF
C458, 459	21-11031A65	1800 pF
C601	23-11048B19	Alu 47 20%; 16 V
C604	8-11051A17	Mtlz Polyest. 47; 63 V
C605	8-11051A06	Mtlz Polyest .0068; 63 V
C606	23-11048B13	Alu 10 20%; 16 V
C607	23-11048B05	Alu 1, 20%
C608	8-11051A10	Mtlz Polyest .033; 63 V
C609	8-11051A01	Mtlz Polyest .001; 63 V
C610	8-11051A03	Mtlz Polyest .0022; 63 V
C611	21-11031A37	82 pF
C701	21-11032A21	.01; 10%
C702	21-11031A15	10 pF ±.5pF
C703	21-11031A17	12 pF
C704, 705	21-11032A13	.0022; 10%
C706	23-11048B19	Alu 47 20%; 16 V
C707	23-11048B05	Alu 1, 20%
C708, 709	21-11031A39	100 pF
C710	23-11048B13	Alu 10 20%; 16 V
C712	23-84538G02	Tant 4.7 20%; 20 V
C713 thru 724	21-11031A51	330 pF
C731	21-11031A39	100
C733	21-11031A21	18 pF
C801	8-11051A06	Mtlz Polyest .0068; 63 V
C802	8-11044A34	Mtlz Polyest .018; 63 V
C803	8-11051A01	Mtlz Polyest .001; 63 V
C901	21-11032A21	.01; 10%
C902	23-11048B05	Alu 1; 20%
C903	21-11031A61	1000 pF
		<u>DIODE:</u> (SEE NOTE)
CR401	48-83654H02	silicon
CR402	48-83654H01	silicon
CR451	48-83654H01	silicon

PARTS LIST

REF SYMBOL	MOTOROLA PART NO.	DESCRIPTION
CR601	48-83654H01	silicon
CR703	48-82178A06	germanium
CR705	48-83654H01	silicon
CR740	48-82178A06	germanium
<u>CONNECTOR, receptacle:</u>		
J4	9-80060K01	female, 15-contact
<u>JUMPER:</u>		
JU404	6-11009F23	0 ohms resistor
JU602	6-11009F23	0 ohms resistor
JU701 thru 704	6-11009F23	0 ohms resistor
JU707	6-11009F23	0 ohms resistor
JU712	6-11009F23	0 ohms resistor
JU717	6-11009F23	0 ohms resistor
JU720	6-11009F23	0 ohms resistor
<u>COIL, rf:</u>		
L401	24-83961B02	choke green
L601	24-82415N02	10KUH
L701, 702	24-83961B02	choke w/slv green
L703	24-11047C63	choke 39 uH
<u>CONNECTOR, plug:</u>		
P3	28-80261H01	male, 11-contact
P6	28-80260H01	male, 6-contact
<u>TRANSISTOR: (SEE NOTE)</u>		
Q401	48-00869619	PNP; type M9619
Q402	48-02081B30	NPN; type M1B30
Q403	48-00869681	PNP; type M9681
Q451	48-00869619	PNP; type M9619
Q452, 453	48-02081B30	NPN; type M1B30
Q601	48-02081B31	PNP; type M1B31
Q701, 702	48-02081B30	NPN; type M1B30
Q705	48-02081B31	PNP; type M1B31
Q710, 711	48-02081B30	NPN; type M1B30
Q714	48-02081B31	PNP; type M1B31
Q715	48-02081B30	NPN; type M1B30
Q721	48-02081B30	NPN; type M1B30
Q901	48-00869577	silicon controlled rectifier; type M9577
Q902	48-02081B30	NPN; type M1B30
<u>RESISTOR, fixed: chip ±5%; 1/8 W unless otherwise stated</u>		
R401	6-11024A51	1200
R402	6-10621C18	FMF 1740, 1%; 1/4 W
R403	6-10621C28	FMF 2210, 1%; 1/4 W

PARTS LIST

REF SYMBOL	MOTOROLA PART NO.	DESCRIPTION
R404	6-11024A73	10k
R405, 406	6-11024A45	680
R407	17-02280M31	Metal Film 330
R408, 409	6-11024A57	2200
R410	6-11024A35	270
R411	6-11024A49	1000
R414, 415	6-11024A01	10
R416	6-11024A73	10k
R451	6-11024A75	12k
R452	6-11024A65	4700
R453	18-05500L08	variable 22k; 20%
R454	6-11024A47	820
R455	18-05500L08	variable 22k; 20%
R456	6-11024A65	4700
R457	6-11024A45	680
R458	6-11024A57	2200
R459	6-11024A45	680
R460	17-02280M31	Metal Film 330
R461	6-11024A51	1200
R462	6-11024A37	330
R463	18-05500L08	variable 22k; 20%
R464	6-11024A49	1000
R465	6-11024A73	10k
R467	6-11024A97	100k
R601	6-11024A25	100
R602	6-11024A43	560
RR604, 605	6-11024A73	10k
R606	6-11024A83	27k
R607	6-11024A65	4700
R608	6-11024A73	10k
R609	6-11024B17	620k
R610	6-11024A69	6800
R611	6-11024A65	4700
R612, 613	6-11024A77	15k
R614	6-11024A83	33k
R615, 616	6-11024A97	100k
R617	6-11024A25	100
R702	6-11024A89	47k
R703	6-11024B22	1 meg
R704	6-11024A73	10k
R705	6-11024A89	47k
R706, 707	6-11024A73	10k
R711	6-11024A89	47k
R712, 713	6-11024A73	10k
R714	6-11024A89	47k
R715	6-11024A73	10k
R719	6-11024A89	47k
R727	6-11024A89	47k

PARTS LIST

REF SYMBOL	MOTOROLA PART NO.	DESCRIPTION
R728	6-11024A97	100k
R729	6-11024A89	47k
R730 thru 733	6-11024A73	10k
R736	6-11024A73	10k
R737, 738	6-11024A89	47k
R739	6-11024A73	10k
R740	6-11024A89	47k
R741	6-11024A65	4700
R742, 743	6-11024A73	10k
R744	6-11024A89	47k
R745	6-11024A57	2200
R746	6-11024A61	3300
R749	6-11024A73	10k
R751, 752	6-11024A73	10k
R760	6-11024A89	47k
R761, 762	6-11024A73	10k
R763	6-11024A89	47k
R764	6-11024A73	10k
R767	6-11024A57	2200
R769	6-11024A89	47k
R770	6-11024A61	3300
R771	6-11024A89	47k
R774 thru 777	6-11024A65	4700
R801	6-11024J18	200k 1%
R802	6-11024H88	100k 1%
R803	6-11024J18	200k 1%
R804	6-11024H88	100k 1%
R805	6-11024J18	200k 1%
R806	6-11024H88	100k 1%
R807, 808	6-11024J18	200k 1%
R809, 810	6-11024A97	100k
R830	6-11024A89	47k
R901, 902	6-11024A73	10k
R903	6-11024B06	220k
R904, 905	6-11024A97	100k
R906	6-11024A89	47k
R907	6-11024A87	39k
R908	6-11024A73	10k
<u>INTEGRATED CIRCUIT: (SEE NOTE)</u>		
U401	51-82609M33	dual operational amplifier
U402	51-80068C06	5 V voltage regulator
U601	51-83629M06	quad operational amplifier
U701	51-97018C01	microprocessor
U704	51-84320A32	7 segment LED driver
U705	51-83627M42	8 stage shift/storage register

PARTS LIST

REF SYMBOL	MOTOROLA PART NO.	DESCRIPTION
VR401	48-83461E40	<u>VOLTAGE REGULATOR:</u> (SEE NOTE) Zener, 5.1 V
Y701	48-80173D08	<u>CRYSTAL:</u> 4.9248 MHz
		<u>NON-REFERENCE ITEMS:</u>
	3-80269H01	SCREW, tapping 2.5 mm
	3-80269H01	SCREW, tapping 2.5 mm
	5-84899A01	RIVET
	14-80067K01	INSULATOR, connector
	14-82392E02	INSULATOR, cover
	14-80066K01	INSULATOR, audio regulator
	75-05295B01	PAD, crystal base
	26-80212H01	HEAT SINK
	9-80269B04	SOCKET, dual in line IC (U701)
	9-80269B08	SOCKET, dual in line IC (U702, U703)

NOTE: For optimum performance, diodes, transistors, crystals and integrated circuits must be ordered by Motorola part numbers.

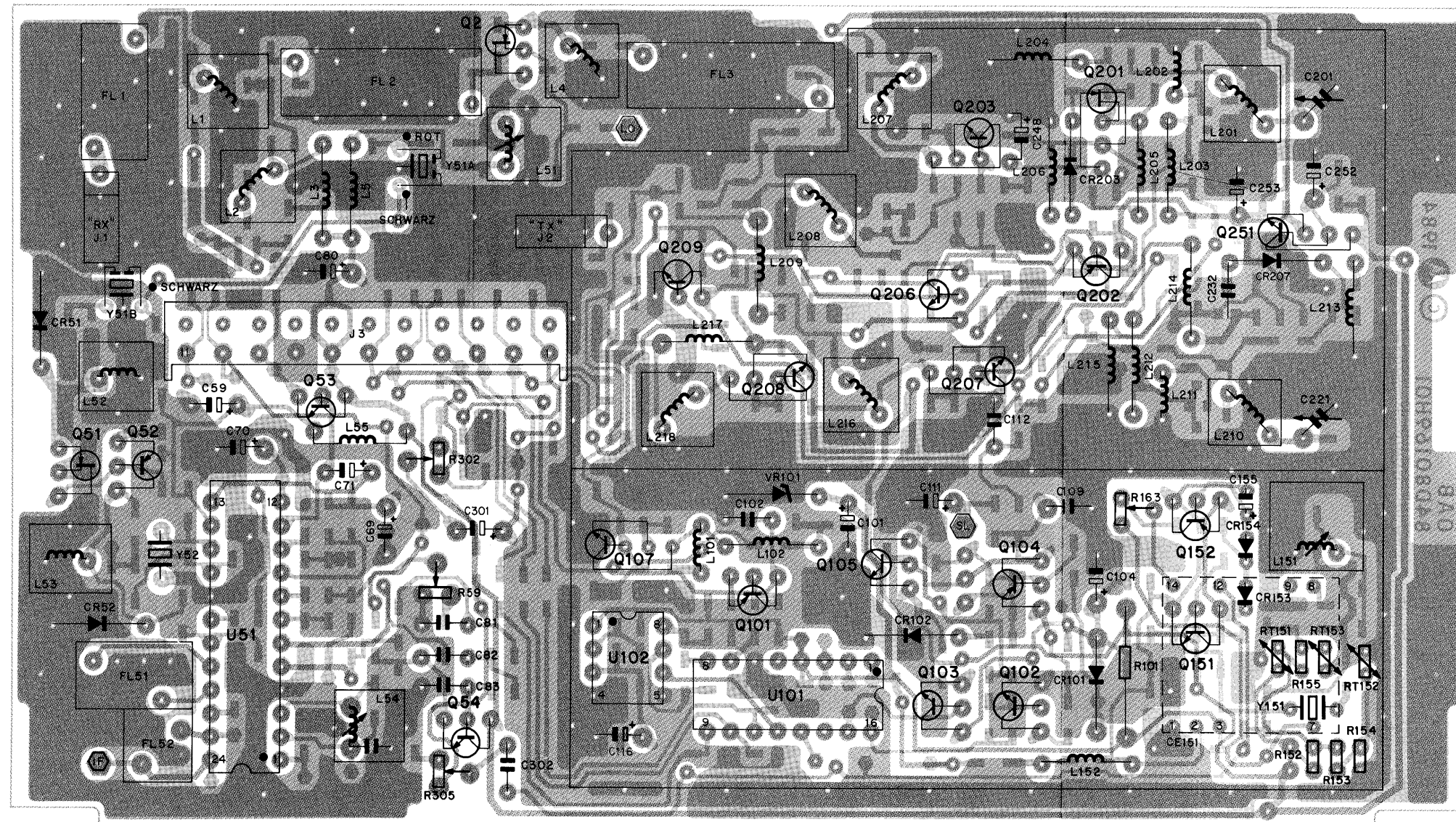

SHOWN FROM COMPONENT SIDE

SOLDER SIDE ● GDW-1542-A (REV)
 COMPONENT SIDE ● GDW-1541-A
 OVERLAY — GDW-1543-A

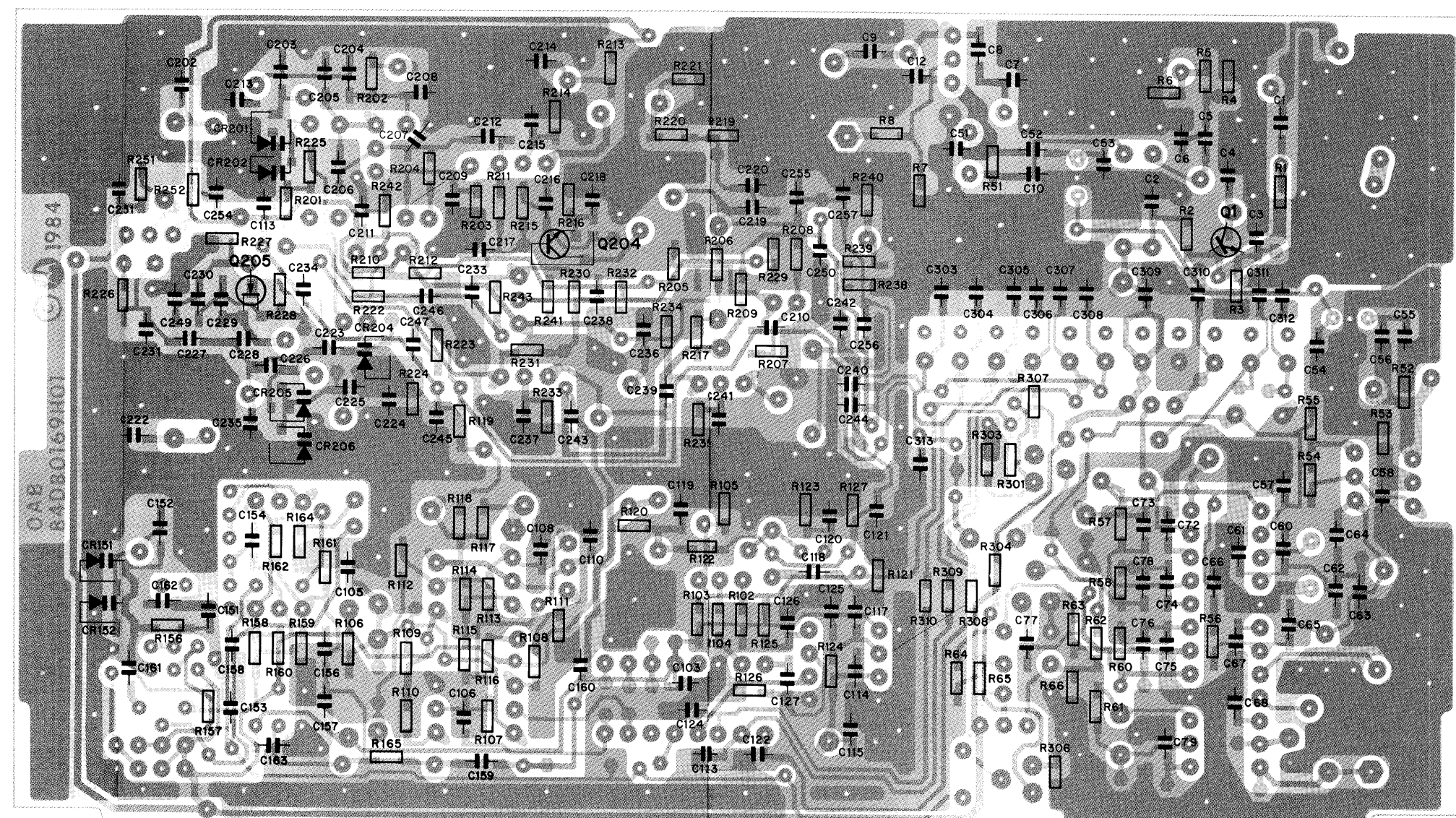

SHOWN FROM SOLDER SIDE

SOLDER SIDE ● GDW-1542-A (REV)
 COMPONENT SIDE ● GDW-1541-A
 OVERLAY — GDW-1544-A

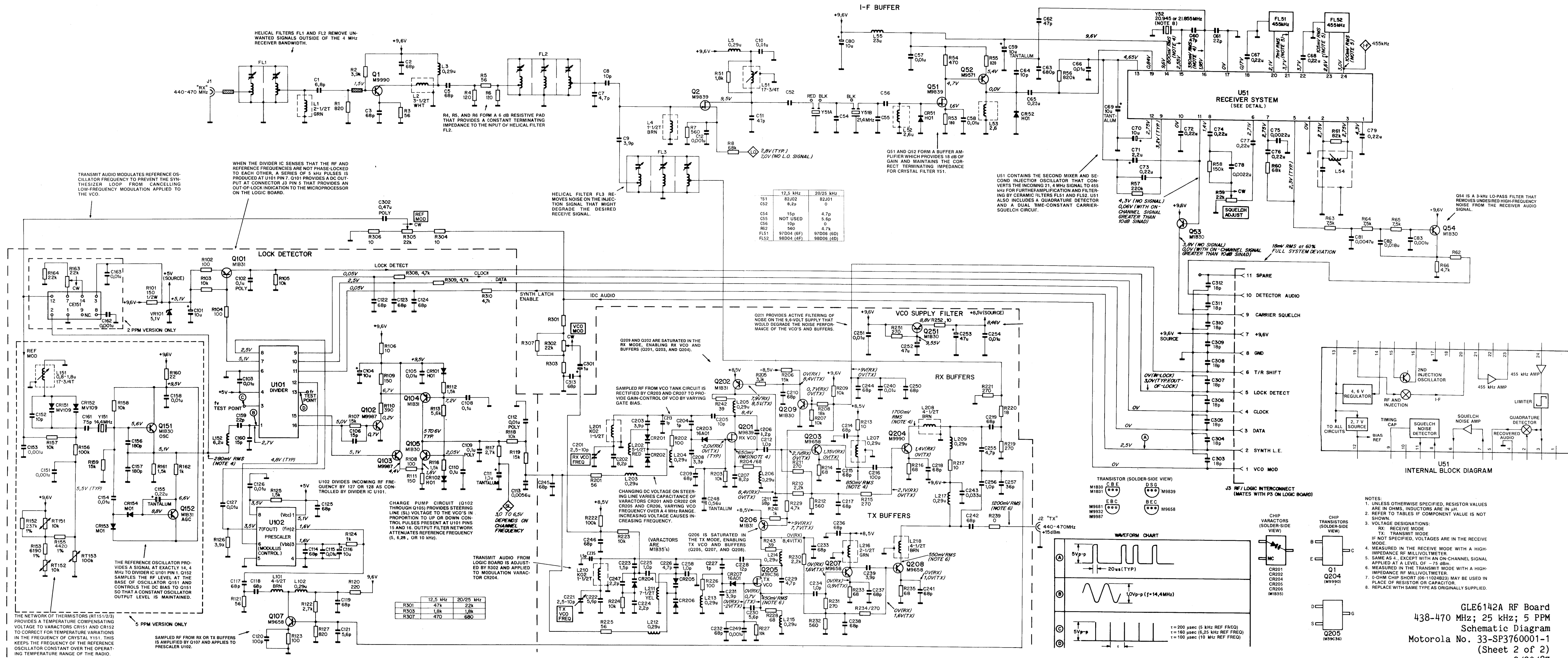

PARTS LIST

REF SYMBOL	MOTOROLA PART NO.	DESCRIPTION
		<u>CAPACITOR, fixed:</u> chip, pF $\pm 5\%$; 50V unless otherwise stated
C1	2111031A11	6.8 0.5pF
C2	2111031A35	68
C3	2111031A35	68
C5	2111031A35	68
C7	2111031A09	4.7 0.25pF
C8	2111031A15	10 0.5pF
C9	2111031A08	3.9 0.25pF
C10	2111032A21	.01uF $\pm 10\%$
C12	2111032A09	.001uF $\pm 10\%$
C51	2111031A31	47
C52	0611024B23	resistive chip jumper
C54	2111031A09	4.7 0.25pF
C55	2111031A10	5.6 0.5pF
C56	0611024B23	resistive chip jumper
C57	2111032A21	.01uF $\pm 10\%$
C58	2111032A21	.01uF $\pm 10\%$
C59	2302057B04	tant 15uF $\pm 20\%$ 25V
C60	2111031A31	47
C61	2111031A23	22
C62	2111031A31	47
C63	2111031A59	680
C64	2111031A15	10 0.5pF
C65	2111032B15	0.22uF +80-20%
C66	2111032A21	.01uF $\pm 10\%$
C67	2111032B15	0.22uF +80-20%
C68	2111032B15	0.22uF +80-20%
C69	2311013D57	tant 10uF $\pm 20\%$ 20V
	or	
	2384538G05	tant 10uF $\pm 20\%$ 15V
C70	2311048B13	alu 10uF $\pm 20\%$ 16V
C71	2311048B06	alu 2.2uF $\pm 20\%$
C72	2111032B15	0.22uF +80-20%
C73	2111032B15	0.22uF +80-20%
C74	2111032B15	0.22uF +80-20%
C75	2111032A13	.0022uF $\pm 10\%$
C76	2111032B15	0.22uF +80-20%
C77	2111032B15	0.22uF +80-20%
C78	2111032A13	.0022uF $\pm 10\%$
C79	2111032B15	0.22uF +80-20%
C80	2311048B13	alu 10uF $\pm 20\%$ 16V
C81	0811051A05	mtlz polyest .0047uF ± 5 63V
C82	0811044A34	mtlz polyest .018uF ± 5 63V
C83	0811051A01	mtlz polyest .001uF ± 5 63V

PARTS LIST

REF SYMBOL	MOTOROLA PART NO.	DESCRIPTION
C101	2311048B13	alu 10uF ±20% 16V
C102	0811051A13	mtlz polyest 0.1uF ±5 63V
C103	2111032A21	.01uF ±10%
C104	2311048B13	alu 10uF ±20% 16V
C105	2111032A21	.01uF ±10%
C106	2111031A19	15
C108	2111032B13	0.1uF +80-20%
C109	0811051A13	mtlz polyest 0.1uF ±5 63V
C110	2111032B13	0.1uF +80-20%
C111	2302057B02	tant ±20% 35V
C112	0811051A07	mtlz polyest .01uF ±5 63V
C113	2111032A13	.0022uF ±10%
C114	2111031A35	68
C115	2111032A21	.01uF ±10%
C116	2311048B13	alu 10uF ±20% 16V
C117	2111031A35	68
C118	2111031A35	68
C119	2111031A35	68
C120	2111031A39	100
C121	2111031A10	5.6 0.5pF
C122	2111031A35	68
C123	2111031A35	68
C124	2111031A35	68
C125	2111031A35	68
C126	2111032A21	.01uF ±10%
C127	2111032A21	.01uF ±10%
C151	2111032A09	.001uF ±10%
C152	2111031A15	10 0.5pF
C153	2111032A09	.001uF ±10%
C154	2111032A21	.01uF ±10%
C155	2302057B09	tant 0.22 ±20% 35V
C156	2111031A45	180
C157	2111031A45	180
C158	2111032A21	.01uF ±10%
C159	2111031A23	22
C160	2111031A19	15
C161	2111031A36	75
C201	2002473M01	cer trimmer 3-10pF
C202	2111031A13	8.2 0.5pF
C203	2111031A08	3.9 0.25pF
C204	2111031A01	1.0 0.25
C205	2111031A15	10 0.5pF
C206	2111031A13	8.2 0.5pF
C207	2111031A13	8.2 0.5pF
C208	2111031A07	3.3 0.25pF
C209	2111031A35	68

PARTS LIST

REF SYMBOL	MOTOROLA PART NO.	DESCRIPTION
C210	2111031A35	68
C211	2111031A35	68
C212	2111031A01	1.0 0.25pF
C213	2111031A01	1.0 0.25pF
C214	2111031A35	68
C215	2111031A35	68
C216	2111031A39	100
C217	2111031A35	68
C218	2111031A35	68
C219	2111031A35	68
C221	2002473M01	cer trimmer 3-10pF
C222	2111031A10	5.6 0.5pF
C223	2111031A03	1.5 0.25pF
C224	2111031A05	2.2 0.25pF
C225	2111031A01	1.0 0.25pF
C226	2111031A09	4.7 0.25pF
C227	2111031A01	1.0 0.25pF
C228	2111031A17	12
C229	2111031A09	4.7 0.25pF
C230	2111031A10	5.6 0.5pF
C231	2111031A08	3.9 0.25pF
C232	2111031A35	68
C233	2111031A35	68
C234	2111031A01	1.0 0.25pF
C235	2111031A03	1.5 0.25pF
C236	2111031A35	68
C237	2111031A35	68
C238	2111031A35	68
C239	2111031A08	3.9 0.25pF
C240	2111032A21	.01 ±10%
C241	2111031A35	68
C242	2111031A35	68
C243	2111032A27	.033 ±10%
C244	2111031A35	68
C245	2111031A35	68
C246	2111031A35	68
C247	2111031A05	2.2 0.25pF
C248	2311013F10	tant 0.56uF ±10% 35V
	or	
	2384538G31	tant 0.56uF ±10% 35V
C249	2111032A09	.001uF ±10%
C250	2111031A35	68
C251	2111032A21	.01uF ±10%
C252	2311048B19	alu 47 ±20% 16V
C253	2311048B19	alu 47 ±20% 16V
C254	2111032A21	.01uF ±10%

PARTS LIST

REF SYMBOL	MOTOROLA PART NO.	DESCRIPTION
C255	2111031A09	4.7 0.25pF
C256	2111031A01	1.0 0.25pF
C257	2111031A28	36
C258	2111031A01	1 0.25pF
C301	2311048B05	alu 1 ±20%
C302	0811051A17	mtlz polyest 0.47uF ±5 63V
C303	2111031A21	18
C304	2111031A21	18
C305	2111031A21	18
C306	2111031A21	18
C307	2111031A21	18
C308	2111031A21	18
C309	2111031A21	18
C310	2111031A21	18
C311	2111031A21	18
C312	2111031A21	18
C313	2111031A35	68
<u>DIODE: (SEE NOTE)</u>		
CR51	4883654H01	silicon
CR52	4883654H01	silicon
CR101	4883654H01	silicon
CR102	4883654H01	silicon
CR151	4882190H54	varactor
CR152	4882190H54	varactor
CR153	4884399M01	silicon
CR154	4884399M01	silicon
CR201	4802081B35	varactor
CR202	4802081B35	varactor
CR203	4884616A01	hot carrier
CR204	4802081B35	varactor
CR205	4802081B35	varactor
CR206	4802081B35	varactor
CR207	4884616A01	hot carrier
<u>FILTER:</u>		
FL1	9180081J01	helical, 2 cell
FL2	9180081J02	helical, 3 cell
FL3	9180081J03	helical, 3 cell
FL51	9180097D06	ceramic, 6 pole
FL52	9180098D06	ceramic, 4 pole
<u>CONNECTOR, receptacle:</u>		
J1,2	0980168K01	female, coaxial
J3	0980179H01	female, 11 contact

PARTS LIST

REF SYMBOL	MOTOROLA PART NO.	DESCRIPTION
		<u>COIL, rf:</u>
L1	2411030B05	2.5 turns grn
L2	2411030B07	3.5 turns wht
L3	2482723H28	0.29uH yel
L4	2411030B01	1.5 turns brn
L5	2482723H28	0.29uH yel
L51	2480299D01	org 17 3/4 turns
L52	2482835G03	choke 2.6uH red/blu/gld
L53	2482835G03	choke 2.6uH red/blu/gld
L54	2580000E01	xfmr 455 khz
L55	2482723H35	23uH red
L101	2411030B08	4.5 turns brn
L102	2482723H28	0.29uH yel
L151	2480299D01	org 17 3/4 turns
L152	2482723H37	6.2uH blu
L201	2480117K02	20nH
L202	2411030B10	5.5 turns red
L203	2482723H28	0.29uH yel
L204	2482723H28	0.29uH yel
L205	2482723H28	0.29uH yel
L206	2482723H28	0.29uH yel
L207	2482723H28	0.29uH yel
L208	2411030B08	4.5 turns brn
L209	2482723H28	0.29uH yel
L210	2480117K02	20nH
L211	2411030B12	7.5 turns yel
L212	2482723H28	0.29uH yel
L213	2482723H28	0.29uH yel
L214	2482723H28	0.29uH yel
L215	2482723H28	0.29uH yel
L216	2411030B05	2.5 turns grn
L217	2482723H28	0.29uH yel
L218	2411030B08	4.5 turns brn
		<u>TRANSISTOR: (SEE NOTE)</u>
Q1	4802081B37	NPN type M1B37
Q2	4800869839	FET N-channel type M9839
Q51	4800869839	FET N-channel type M9839
Q52	4800869571	PNP type M9571
Q53	4802081B30	NPN type M1B30
Q54	4802081B30	NPN type M1B30
Q101	4802081B31	PNP type M1B31
Q102	4800869987	NPN type M9987
Q103	4800869987	NPN type M9987
Q104	4802081B31	PNP type M1B31
Q105	4802081B30	NPN type M1B30
Q107	4800869658	NPN type M9658

PARTS LIST

REF SYMBOL	MOTOROLA PART NO.	DESCRIPTION
Q151	4802081B30	NPN type M1B30
Q152	4802081B31	PNP type M1B31
Q201	4800869839	FET N-channel type M9839
Q202	4802081B31	PNP type M1B31
Q203	4800869658	NPN type M9658
Q204	4802081B37	NPN type M1B37
Q205	4805128M66	FET N-channel type M2866
Q206	4802081B31	PNP type M1B31
Q207	4800869658	NPN type M9658
Q208	4800869658	NPN type M9658
Q209	4802081B30	NPN type M1B30
Q251	4802081B30	NPN type M1B30
<u>RESISTOR, fixed: chip, ±5%; 1/8W</u> unless otherwise stated		
R1	0611024A47	820
R2	0611024A63	3900
R3	0611024A19	56
R4	0611024A27	120
R5	0611024A19	56
R6	0611024A27	120
R7	0611024A43	560
R8	0611024A93	68k
R51	0611024A55	1800
R53	0611024A31	180
R54	0611024A41	470
R55	0611024A47	820
R56	0611024B20	820k
R57	0611024B06	220k
R58	0611024B02	150k
R59	1805500L08	variable 22k ±20%
R60	0611024A93	68k
R61	0611024A95	82k
R62	0611024A65	4700
R63	0611024A70	7500
R64	0611024A70	7500
R65	0611024A70	7500
R66	0611024A65	4700
R101	0602369M27	FMF 150 ±5% 0.6W
R102	0611024A25	100
R103	0611024A73	10k
R104	0611024A25	100
R105	0611024A73	10k
R106	0611024A01	10
R107	0611024A77	15k
R108	0611024A25	100
R109	0611024A29	150
R110	0611024A39	390

PARTS LIST

REF SYMBOL	MOTOROLA PART NO.	DESCRIPTION
R111	0611024A29	150
R112	0611024A53	1500
R113	0611024A67	5600
R116	0611024A53	1500
R117	0611024A59	2700
R118	0611024A73	10k
R119	0611024A77	15k
R120	0611024A33	220
R121	0611024A19	56
R122	0611024A59	2700
R123	0611024A25	100
R124	0611024A49	1000
R125	0611024A53	1500
R126	0611024A63	3900
R127	0611024A47	820
R152	0610621E25	FMF 237k $\pm 1\%$ 1/4W
R153	0610621C71	FMF 6190 $\pm 1\%$ 1/4W
R155	0610621C57	FMF 4420 $\pm 1\%$ 1/4W
R156	0611024A97	100k
R157	0611024A73	10k
R158	0611024A73	10k
R159	0611024A77	15k
R160	0611024A09	22
R161	0611024A53	1500
R162	0611024A49	1000
R201	0611024A19	56
R202	0611024A25	100
R203	0611024A73	10k
R204	0611024A21	68
R205	0611024A61	3300
R206	0611024A77	15k
R207	0611024A73	10k
R208	0611024A79	18k
R209	0611024A73	10k
R210	0611024A57	2200
R211	0611024A35	270
R212	0611024A43	560
R213	0611024A01	10
R214	0611024A21	68
R215	0611024A35	270
R216	0611024A21	68
R217	0611024A01	10
R219	0611024A35	270
R220	0611024A07	18
R221	0611024A35	270
R222	0611024A97	100k
R223	0611024A73	10k
R224	0611024A73	10k

PARTS LIST

REF SYMBOL	MOTOROLA PART NO.	DESCRIPTION
R225	0611024A19	56
R226	0611024A25	100
R227	0611024A73	10k
R228	0611024A21	68
R229	0611024A65	4700
R230	0611024A57	2200
R231	0611024A35	270
R232	0611024A43	560
R233	0611024A21	68
R234	0611024A35	270
R235	0611024A21	68
R239	0611024B23	jumper 0 ohms
R241	0611024A49	1000
R242	0611024A15	39
R243	0611024A15	39
R251	0611024A35	270
R252	0611024A01	10
R301	0611024A83	27k
R302	1805500L08	variable 22k \pm 20% 100V
R303	0611024A45	680
R304	0611024A01	10
R305	1805500L08	variable 22k \pm 20% 100V
R306	0611024A01	10
R307	0611024A55	1800
R308	0611024A65	4700
R309	0611024A65	4700
R310	0611024A65	4700
<u>THERMISTOR:</u>		
RT151	0683600K06	10K \pm 5%
RT152	0683600K06	10K \pm 5%
RT153	0683600K05	100K \pm 5%
<u>INTEGRATED CIRCUIT: (SEE NOTE)</u>		
U51	5105479G05	linear receiver system
U101	5183548N19	divider
U102	5183977M45	prescaler
<u>VOLTAGE REGULATOR: (SEE NOTE)</u>		
VR101	4882256C15	zener, 5.1V
<u>CRYSTAL:</u>		
Y51	9180082J01	IF filter
Y52	4805488G03	20.945 MHz
Y151	4802443B21	14.4 MHz

PARTS LIST

REF SYMBOL	MOTOROLA PART NO.	DESCRIPTION
		<u>MECHANICAL PARTS</u>
	1402619B01	INSULATOR (L52)
	2602484M01	SHIELD
	2602498M01	SHIELD
	2680153J01	SHIELD, coil can (L43,51,52); 3 used
	2680153J02	SHIELD, coil can (L1,2,4,207,216,208)
	2680182H01	SHIELD RF
	2680210K01	SHIELD, coil can (L151)
	6680329A63	TOOL, alignment
	7505295B01	PAD, crystal base (Y52,151)

NOTE: For optimum performance, diodes, transistors, crystals and integrated circuits must be ordered by Motorola part numbers.

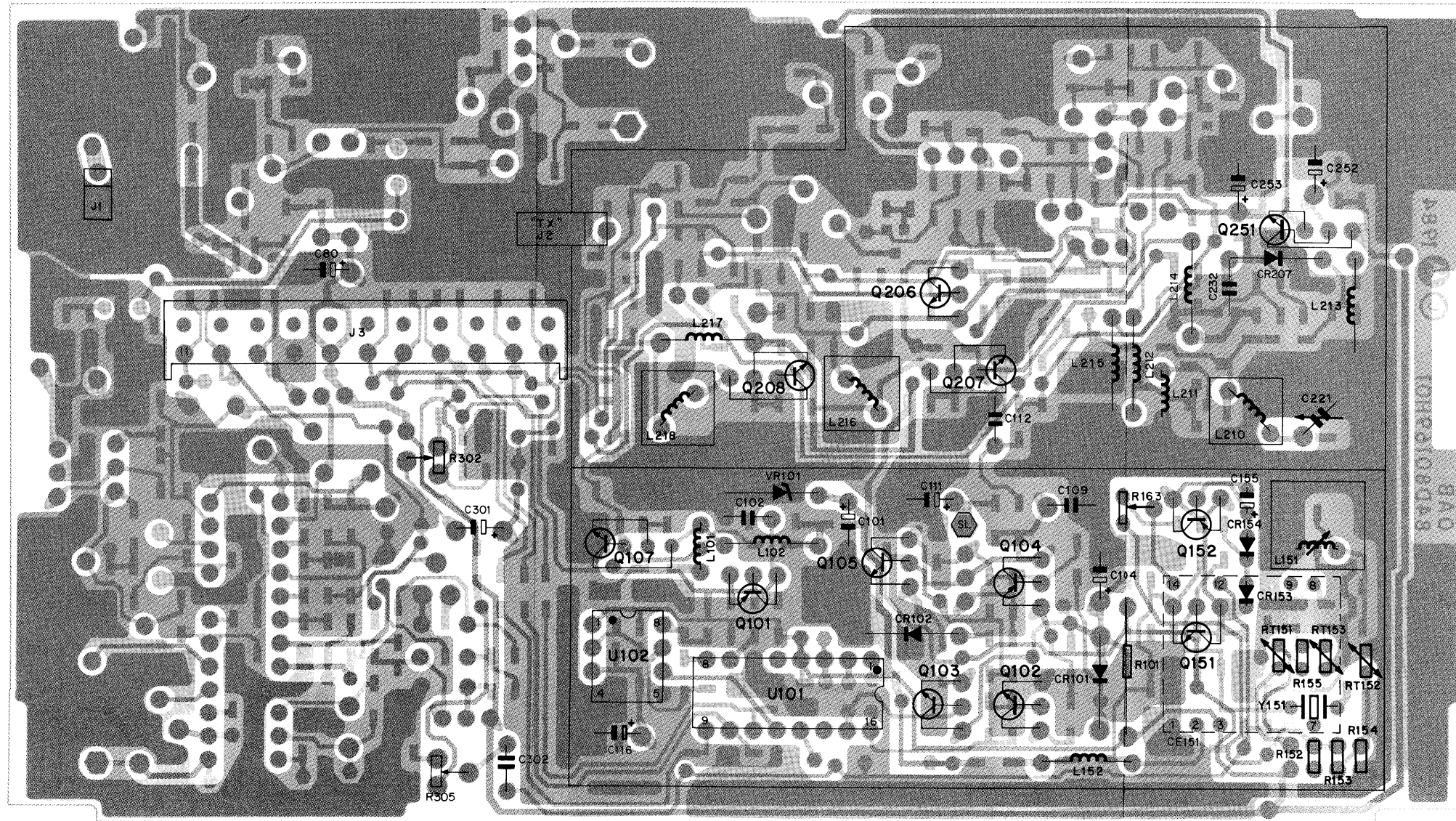

SOLDER SIDE ● BD-DEPS-43525-0
 COMPONENT SIDE ● BD-DEPS-43526-0
 OL-DEPS-43527-0

SHOWN FROM COMPONENT SIDE

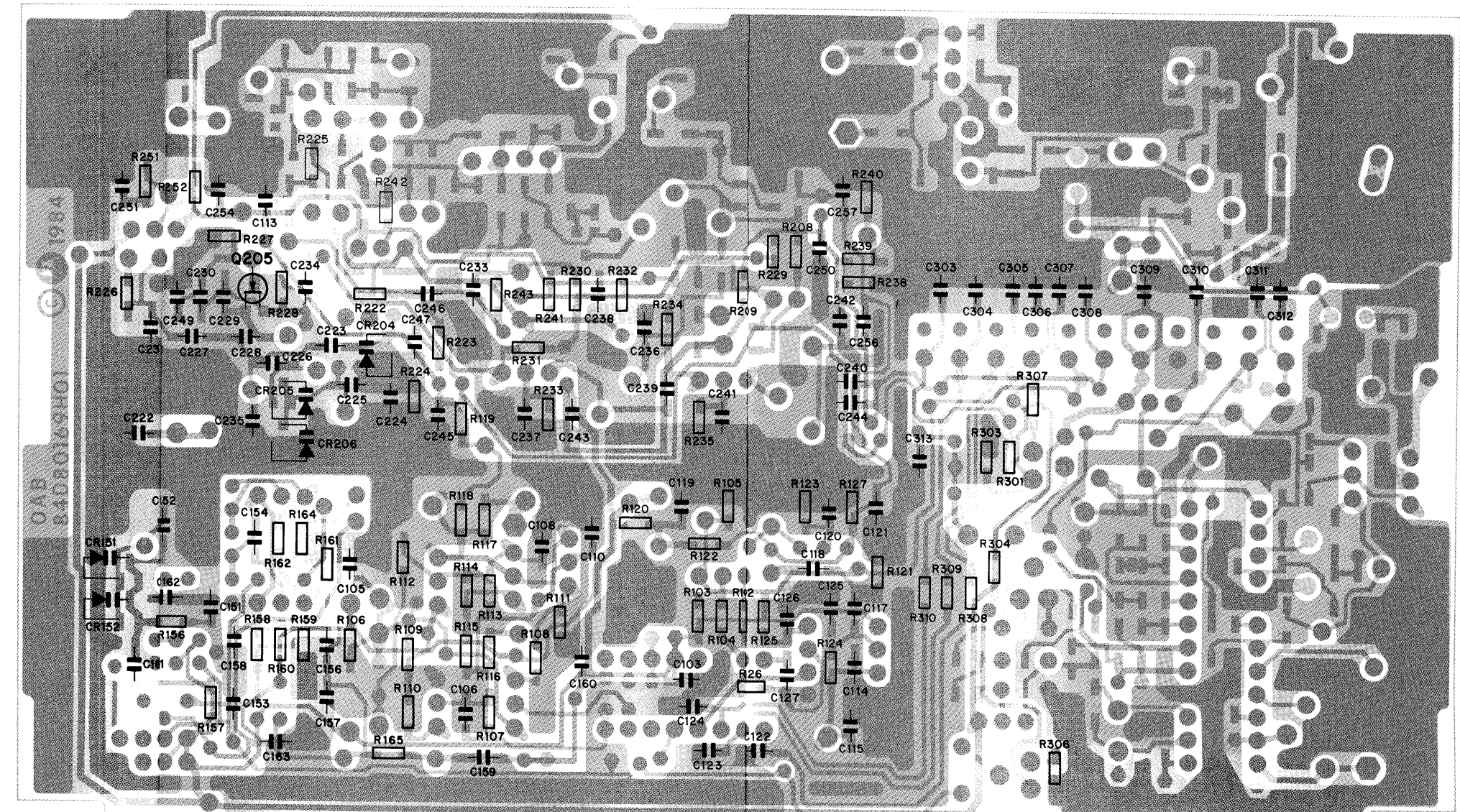

SOLDER SIDE ● BD-DEPS-43525-0 (REV)
 COMPONENT SIDE ● BD-DEPS-43526-0 (REV)
 OL-DEPS-43528-0

SHOWN FROM SOLDER SIDE

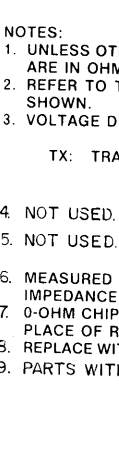
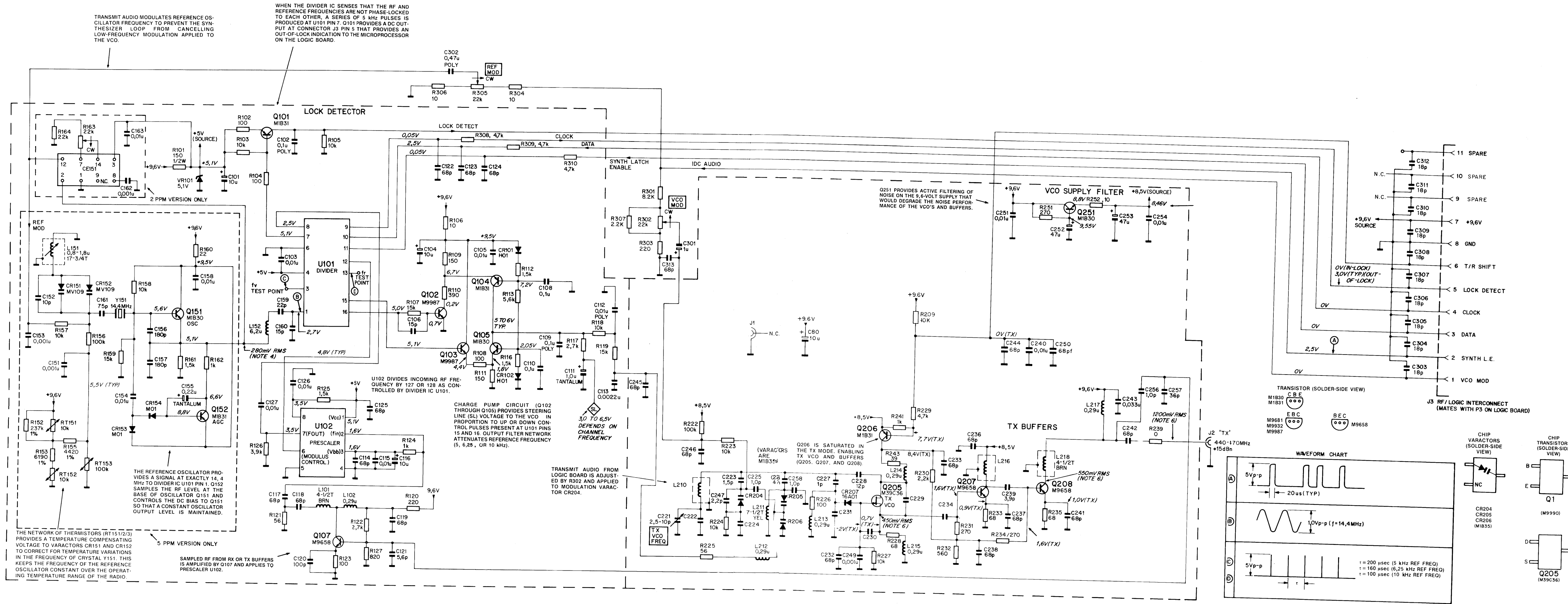

PARTS LIST

REF SYMBOL	MOTOROLA PART NO.	DESCRIPTION
		CAPACITOR, fixed: uF $\pm 5\%$; 50 V; unless otherwise stated
C80	23-11048B13	10 $\pm 20\%$; 16 V
C101	23-11048B13	10 $\pm 20\%$; 16 V
C102	8-11051A13	0.1; 63 V
C103	21-11032A21	.01 $\pm 10\%$
C104	23-11048B13	10 $\pm 20\%$; 16 V
C105	21-11032A21	.01 $\pm 10\%$
C106	21-11031A19	15 pF
C107		0.1
C108	21-11032B13	.01 +80-20%
C109	8-11051A13	0.1; 63 V
C110	21-11032B13	0.1 +80-20%
C111	23-02057B02	1.0 $\pm 20\%$; 35 V
C112	8-11051A07	.01; 63 V
C113	21-11032A13	.0022 $\pm 10\%$
C114	21-11031A35	68 pF
C115	21-11031A21	.01 $\pm 10\%$
C116	23-11048B13	10 $\pm 20\%$; 16 V
C117 thru 119	21-11031A35	68 pF
C120	21-11031A39	100 pF
C121	21-11031A10	5.6 pF $\pm .5\%$
C122 thru 125	21-11031A35	68 pF
C126, 127	21-11031A21	.01 $\pm 10\%$
C159	21-11031A23	22 pF
C160	21-11031A19	15 pF
C162	21-11032A09	.00 $\pm 10\%$
C163	21-11032A21	.01 $\pm 10\%$
C221	20-02473M01	variable, 3-10 pF
C222	21-11031A05	2.2 pF $\pm .25$ pF (GLE6174A)
	21-11031A10	5.6 pF $\pm .5\%$ (GLE6176A)
C223	21-11031A03	1.5 pF $\pm .25$ pF
C224	21-11031A03	1.5 pF $\pm .25$ pF (GLE6174A)
	21-11031A05	2.2 pF $\pm .25$ pF (GLE6176A)
C225	21-11031A01	1.0 pF $\pm .25$ pF
C226	21-11031A09	4.7 pF $\pm .25$ pF
C227	21-11031A01	1 pF $\pm .25$ pF
C228	21-11031A17	12 pF
C229	21-11031A10	5.6 pF $\pm .5\%$ (GLE6174A)
	21-11031A09	4.7 pF $\pm .25$ pF (GLE6176A)
C230	21-11031A11	6.8 pF $\pm .5\%$ (GLE6174A)
	21-11031A10	5.6 pF $\pm .5\%$ (GLE6176A)
C231	21-11031A10	5.6 pF $\pm .5\%$ (GLE6174A)
	21-11031A08	3.9 pF $\pm .25$ pF (GLE6176A)
C232	21-11031A35	68 pF
C233	21-11031A35	68 pF
C234	21-11031A03	1.5 pF $\pm .25$ pF (GLE6174A)
	21-11031A01	1.0 pF $\pm .25$ pF (GLE6176A)

PARTS LIST

REF SYMBOL	MOTOROLA PART NO.	DESCRIPTION
C236 thru 238	21-11031A35	68 pF
C239	21-11031A10	5.6 pF $\pm 5\%$ (GLE6174A)
	21-11031A08	3.9 pF $\pm .25$ pF (GLE6176A)
C240	21-11032A21	.01 $\pm 10\%$
C241, 242	21-11031A35	68 pF
C243	21-11032A27	.033 uF $\pm 10\%$
C244 thru 246	21-11031A35	68 pF
C247	21-11031A05	2.2 pF $\pm .25$ pF
C249	21-11032A09	.001 $\pm 10\%$
C250	21-11031A35	68 pF
C251	21-11032A21	.01 $\pm 10\%$
C252, 253	23-11048B19	47 $\pm 20\%$; 16 V
C254	21-11032A21	.01 $\pm 10\%$
C256	21-11031A01	1.0 pF $\pm .25$ pF
C257	21-11031A28	26 pF
C258	21-11031A01	1.0 pF $\pm .25$ pF
C301	23-11048B05	1 uF $\pm 20\%$
C302	8-11051A17	.47; 63 V
C303 thru 312	21-11031A21	18 pF
C313	21-11031A35	68 pF
<u>DIODE:</u> (SEE NOTE)		
CR101, 102	48-83654H01	silicon
CR204 thru 206	48-02081B35	silicon (varic)
CR207	48-84616A01	hot carrier
<u>CONNECTOR:</u>		
J1, 2	9-80168K01	female; single contact
J3	9-80179H01	female; 6-contact
<u>COIL, rf:</u>		
L101	24-11030B08	4 1/2 turns (brown)
L102	24-82723H28	choke; 0.29 uH (yellow)
L152	24-82723H37	choke, 6.2 uH (blue)
L210	24-80117K03	choke, 35 NH (GLE6174A)
	24-80117K02	choke, 20 NH (GLE6176A)
L211	24-11030B12	7 1/2 turns (yellow)
L212 thru 215	24-82723H28	choke, 0.29 uH (yellow)
L216	24-11030B06	2 1/2 turns (blue) (GLE6174A)
	24-11030B05	2 1/2 turns (green) (GLE6176A)
L217	24-82723H28	choke; 0.29 uH
L218	24-11030B08	4 1/2 turns (brown)

GLE6174A (403-433 MHz) and GLE6176A (438-470 MHz)

Transmit RF Board; 2 PPM

Motorola Parts List (PL-10192-0)

34PL-SP3760001-2

(Sheet 2 of 4) 1/30/87

PARTS LIST

REF SYMBOL	MOTOROLA PART NO.	DESCRIPTION
		<u>TRANSISTOR:</u> (SEE NOTE)
Q101	48-02081B31	PNP; type M1B31
Q102, 103	48-869987	NPN; type M9987
Q104	48-02081B31	PNP; type M1B31
Q105	48-02081B30	NPN; type M1B30
Q107	48-869658	NPN; type M9658
Q205	48-02081B38	field-effect type M39C38
Q206	48-02081B31	PNP; type M1B31
Q207, 208	48-869658	NPN; type M9658
Q251	48-02081B30	NPN; type M1B30
		<u>RESISTOR, fixed:</u> ±5%, 1/8 W; unless otherwise stated
R101	6-02369M27	150; 0.6 W
R102	6-11024A25	100
R103	6-11024A73	10k
R104	6-11024A25	100
R105	6-11024A73	10k
R106	6-11024A01	10
R107	6-11024A77	15k
R108	6-11024A25	100
R109	6-11024A29	150
R110	6-11024A39	390
R111	6-11024A29	150
R112	6-11024A53	1.5k
R113	6-11024A67	5.6k
R116	6-11024A53	1.5k
R117	6-11024A59	2.7k
R118	6-11024A73	10k
R119	6-11024A77	15k
R120	6-11024A33	220
R121	6-11024A19	56
R122	6-11024A59	2.7k
R123	6-11024A25	100
R124	6-11024A49	1k
R125	6-11024A53	1.5k
R126	6-11024A63	3.9k
R127	6-11024A47	820
R163	18-05500L08	variable 22k, ±20%; 100 V
R164	6-11024A81	22k
R209	6-11024A73	10k
R222	6-11024A97	100k
R223	6-11024A73	10k
R224	6-11024A73	10k
R225	6-11024A19	56
R226	6-11024A25	100
R227	6-11024A73	10k
R228	6-11024A21	68

PARTS LIST

REF SYMBOL	MOTOROLA PART NO.	DESCRIPTION
R229	6-11024A65	4.7k
R230	6-11024A57	2.2k
R231	6-11024A35	270
R232	6-11024A43	560
R233	6-11024A21	68
R234	6-11024A35	270
R235	6-11024A21	68
R239	6-11024B23	0 ohms
R241	6-11024A49	1k
R243	6-11024A15	39
R251	6-11024A35	270
R252	6-11024A01	10
R301	6-11024A71	8.2k
R302	18-05500L08	variable, 22k \pm 20%; 100 V
R303	6-11024A33	220
R304	6-11024A01	10
R305	18-05500L08	variable, 22k \pm 20%; 100 V
R306	6-11024A01	10
R307	6-11024A57	2.2k
R308 thru 310	6-11024A65	4.7k
U101	51-83548N19	<u>INTEGRATED CIRCUIT:</u> (SEE NOTE) synthesizer
U102	51-83977M45	dual modules prescaler
VR101	48-82256C15	<u>VOLTAGE REGULATOR:</u> (SEE NOTE) Zener; type 5.1 V
Y151	KXN1123A	<u>CRYSTAL:</u> (SEE NOTE) channel element
	26-80153J02	<u>MECHANICAL PARTS:</u> SHIELD, coil com; 2 used
	26-80182H01	SHIELD, rf
	66-80329A63	TOOL, align

NOTE: For optimum performance, diodes, transistors, crystals and integrated circuits must be ordered by Motorola part numbers.

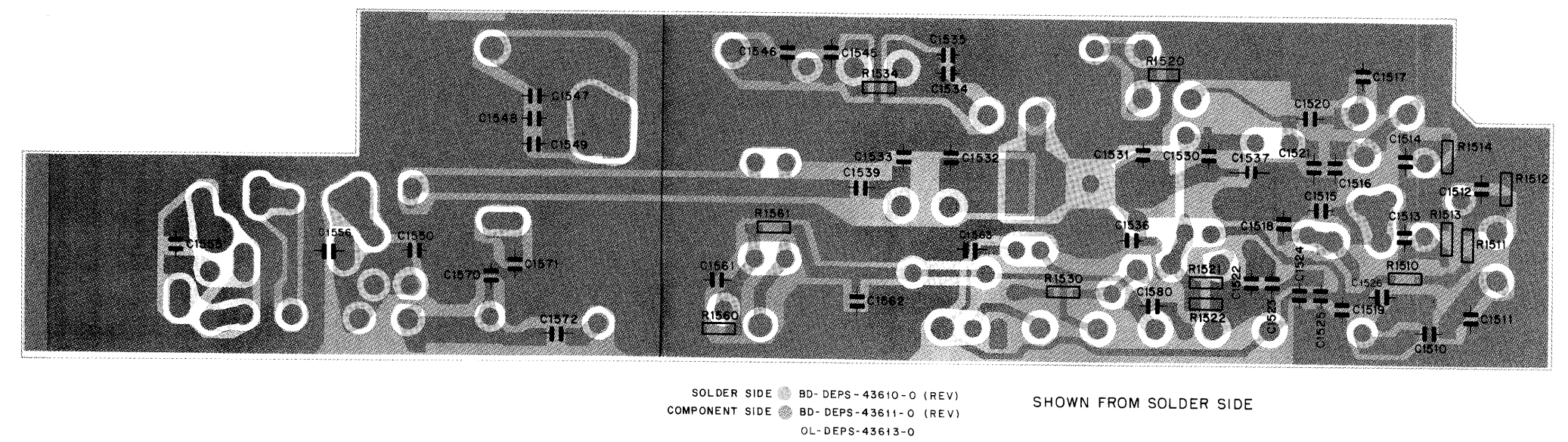
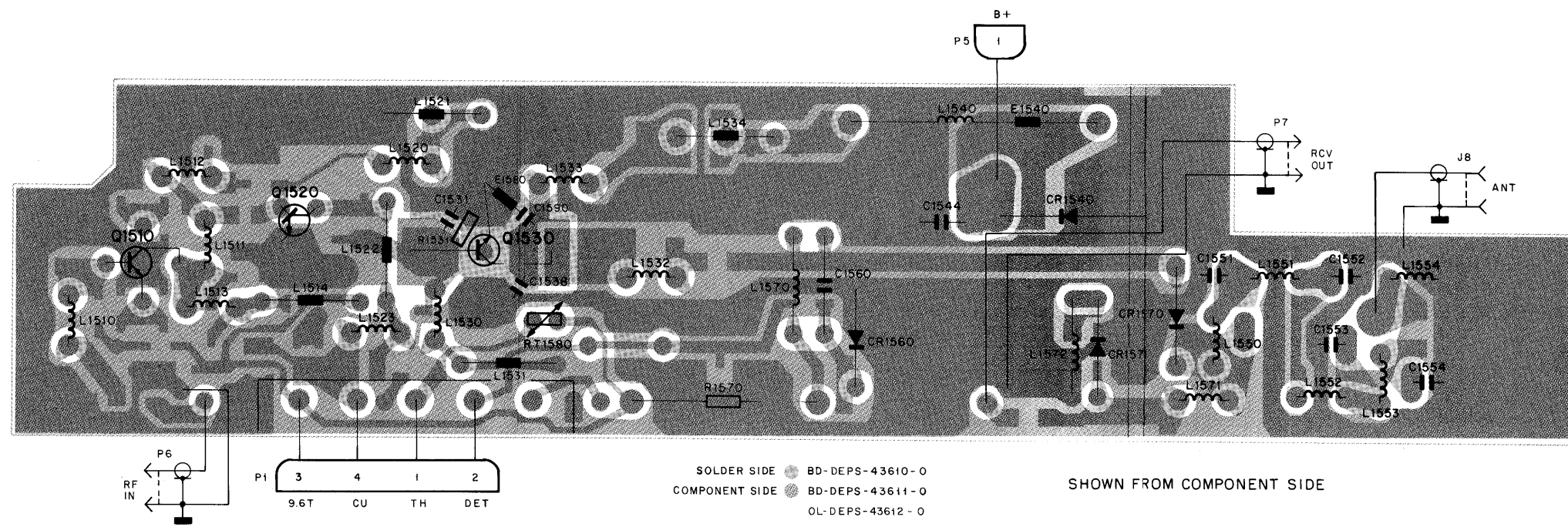

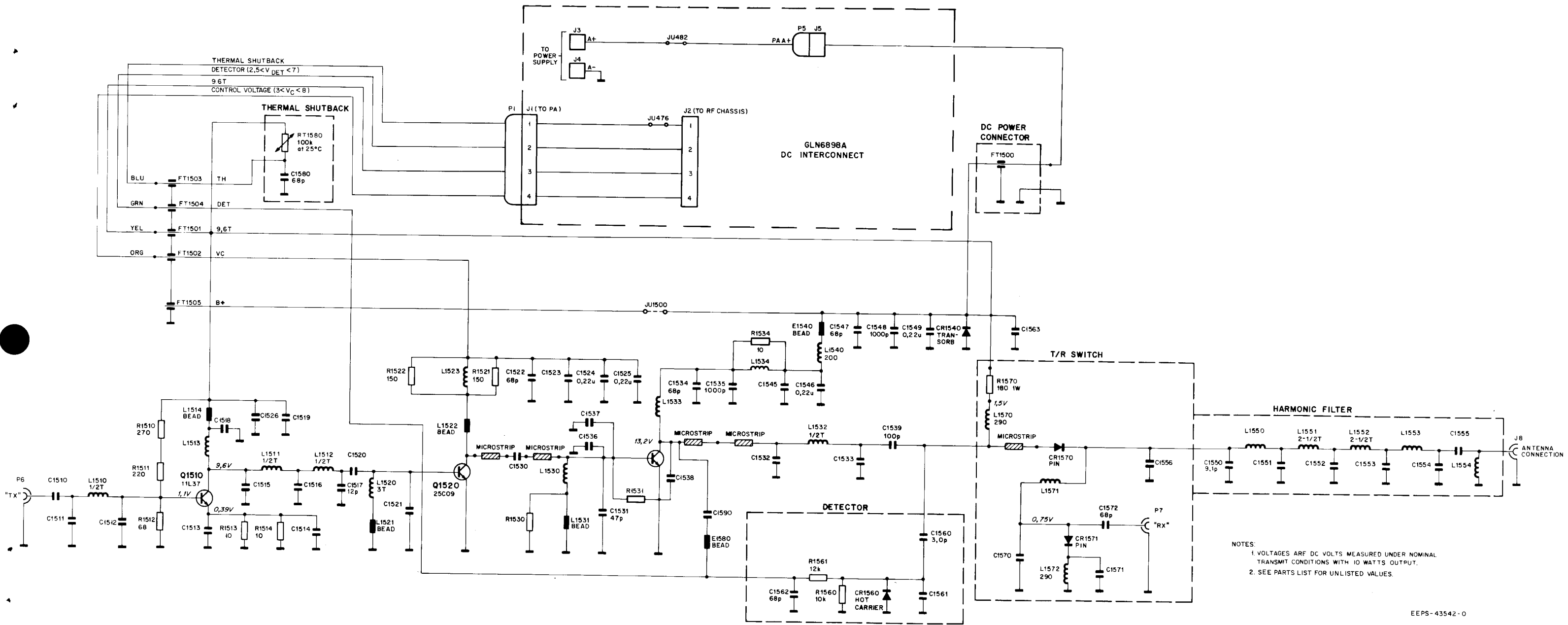

NOTES:
 1. VOLTAGES ARE DC VOLTS MEASURED UNDER NOMINAL TRANSMIT CONDITIONS WITH 10 WATTS OUTPUT.
 2. SEE PARTS LIST FOR UNLISTED VALUES.

EEPS-43542-0

PARTS LIST

REF SYMBOL	MOTOROLA PART NO.	DESCRIPTION
		<u>CAPACITOR, fixed:</u> pF, $\pm 5\%$; 50 V unless otherwise stated
C1510	21-11031A35	68
C1511	21-11031A18	13
C1513, 1514	21-11031A33	56
C1515	21-11031A05	2.2, $\pm .25$ pF
C1516	21-11031A09	4.7, $\pm .25$ pF
C1517	21-11031A17	12
C1518	21-11031A33	56
C1519	21-11032B15	.22 uF +80-20%
C1520	21-11031A35	68
C1521	21-11031A26	30
C1522	21-11031A35	68
C1523 thru 1525	21-11032B15	.22 uF +80-20%
C1526	21-11031A35	68
C1530	21-11031A23	22
C1531	21-11033B29	47, 100 V
C1532	21-11033B23	27, 100 V
C1533	21-11033B08	6.2, $\pm .25$ pF, 100 V
C1534	21-11031A35	68
C1535	21-11032B15	0.22 uF +80-20%
C1539	21-11033B37	100, 100 V
C1540	21-11031A05	2.2 $\pm .25$ pF
C1544	8-11051A17	.47 uF, 63 V
C1545	21-11031A35	68
C1546	21-11032B15	.22 uF +80-20%
C1547	21-11031A35	68
C1548	21-11031A61	.001 uF
C1549	21-11032B15	.22 uF +80-20%
C1550	21-11033B12	9.1, $\pm .5$ pF, 100 V
C1551	21-80240G16	10, 1 pF, 250 V
C1552	21-80240G13	7.5, $\pm .25$ pF, 250 V
C1553	21-82040G16	10, 1 pF, 250 V
C1554	21-80240G15	9.1, $\pm .25$ pF, 250 V
C1555	21-11033B17	15, 100 V
C1560	21-82450B11	3, 500 V
C1561	21-11031A14	9.1, $\pm .5$ pF
C1562	21-11031A35	68
C1570	21-11031A62	5.1, $\pm .25$ pF
C1571	21-11033B19	18, 100 V
C1572, 1580	21-11031A35	68
		<u>DIODE:</u> (SEE NOTE)
CR1540	48-80236E07	28 V Zener
CR1560	48-84616A01	hot carrier
CR1570, 1571	48-83510F04	silicon, PIN
		<u>CONNECTOR, receptacle:</u>
J8	1-02716B69	assembly coax xmit output includes:

PARTS LIST

REF SYMBOL	MOTOROLA PART NO.	DESCRIPTION
	9-82442E01	female; single contact
	15-483599	HOOD, receptacle
	30-83794C01	CABLE, coaxial
	43-03423M01	BUSHING
		<u>COIL:</u>
E1540	76-83960B01	ferrite bead, .5 turn
L1510, 1511	24-11030E01	brown
L1512	24-11030E02	red
L1513	24-11030B11	6.5 turns (orange)
L1514	24-80036A01	ferrite bead, .5 turn
L1520	24-11030A02	3 turns (orange)
L1521, 1522	24-80036A01	ferrite bead, .5 turn
L1523	24-11030A05	6 turns (blue)
L1530	24-11030A02	3 turns (orange)
L1531	24-80036A01	ferrite bead, .5 turn
L1532	24-11030E04	yellow
L1533	24-11030B05	2.5 turns (green)
L1534	24-11030B12	1.5 turns (yellow)
L1540	24-84346A02	.23 uH
L1550	24-11030B04	1.5 turns (yellow)
L1551, 1552	24-11030B05	2.5 turns (green)
L1553	24-11030B04	1.5 turns (yellow)
L1554	24-11030B07	3.5 turns (white)
L1570	24-82723H40	.29 uH (yellow/black)
L1571	24-11030B03	1.5 turns (orange)
L1572	24-82723H40	.29 uH (yellow/black)
		<u>CONNECTOR, plug:</u>
P1	15-82694R03	HOUSING, receptacle
P5	39-82693R02	CONTACT, receptacle crimp snap; 4 used
P6, 7	28-02098M02	male, single contact
	30-80116K06	CABLE, coaxial includes plug
		<u>TRANSISTOR: (SEE NOTE)</u>
Q1510	48-84411L37	NPN; type 11L37
Q1520	48-80225C09	NPN; type M25C09
Q1530	48-80225C19	NPN; type M25C19
		<u>RESISTOR, fixed:</u> Ohms, $\pm 5\%$; 1/8 W unless otherwise stated
R1510	6-11024A35	270
R1511	6-11024A33	220
R1512	6-11024A21	68
R1513, 1514	6-11024A01	10
R1515	6-11024A33	220
R1521, 1522	6-11024A29	150
R1530, 1534	6-11024A01	10

PARTS LIST

REF SYMBOL	MOTOROLA PART NO.	DESCRIPTION
R1560	6-11024A73	10k
R1561	6-11024A75	12k
R1570	6-00126A31	180, 1 W
		<u>MECHANICAL PARTS:</u>
	2-7003	NUT, 8-32 x 5/16 x 1/8"
	2-7018	NUT, 3/8-32 x 1/2 x 3/32"
	3-02607B01	SCREW, taptite M3 x 8 mm; 7 used
	3-02607B02	SCREW, tapite, M3 x 6 mm; 4 used
	3-80165J07	SCREW, machine, M4 x 10 mm
	3-80269H09	SCREW, taptite M5 x .8 mm; 2used
	4-7691	LOCKWASHER, 3/8" internal
	7-03432A01	BRACKET connector
	9-80038K02	CONNECTOR, feed-thru single contact
	26-80092K01	SHIELD
	26-80176H08	HEAT SINK
	29-5318	LUG, soldering; 2 used
	15-03424A01	COVER, PA
	42-82405R01	CLIP, PA
	43-03423A01	BUSHING, coax
	42-10217A02	STRAP, tie: .091 x 362"; 2 used
	26-80222H01	HEAT SINK, copper
	26-80199J01	SHIELD, harmonic filter
	29-80014A01	CLIP, terminal

NOTE: For optimum performance, diodes, transistors, crystals and integrated circuits must be ordered by Motorola part numbers.

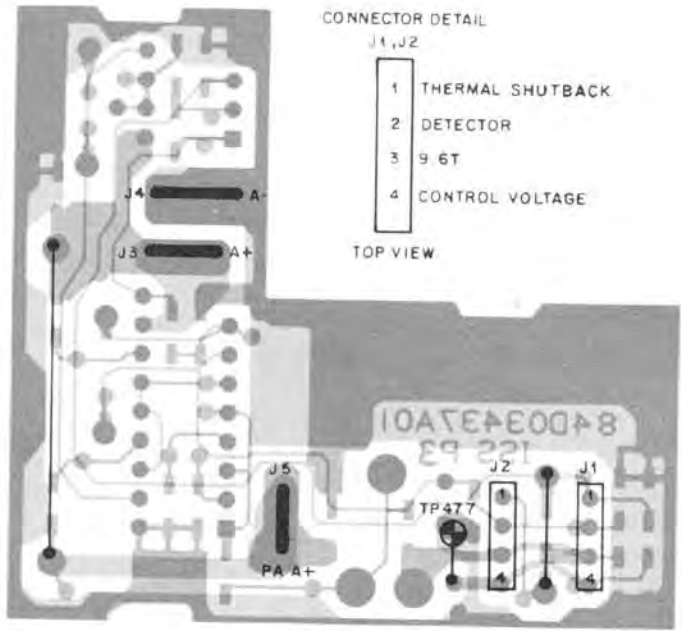

CONNECTOR DETAIL

J1, J2

- | | |
|---|------------------|
| 1 | THERMAL SHUTBACK |
| 2 | DETECTOR |
| 3 | 9.6T |
| 4 | CONTROL VOLTAGE |

TOP VIEW

COMPONENT SIDE ● BD-BEPS-43509-0
 SOLDER SIDE ● BD-BEPS-43510-0
 ● OL-BEPS-43513-0

SHOWN FROM COMPONENT SIDE

PARTS LIST

REF SYMBOL	MOTOROLA PART NO.	DESCRIPTION
J1, 2	28-82697R03	<u>CONNECTOR:</u> male; 4-contact
J3 thru 5	29-10231A10	terminal, single contact
JU476	6-11009D23	<u>JUMPER:</u> 0 ohms resistor
JU482	30-10286A12	Wire, #16

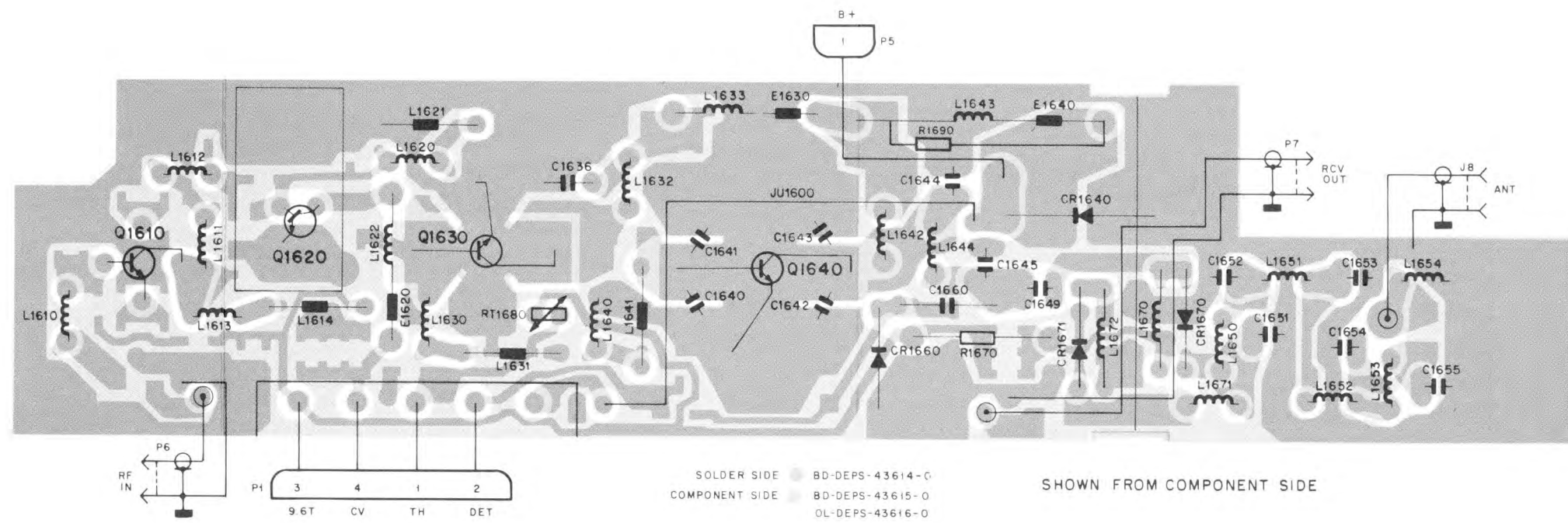

SHOWN FROM COMPONENT SIDE

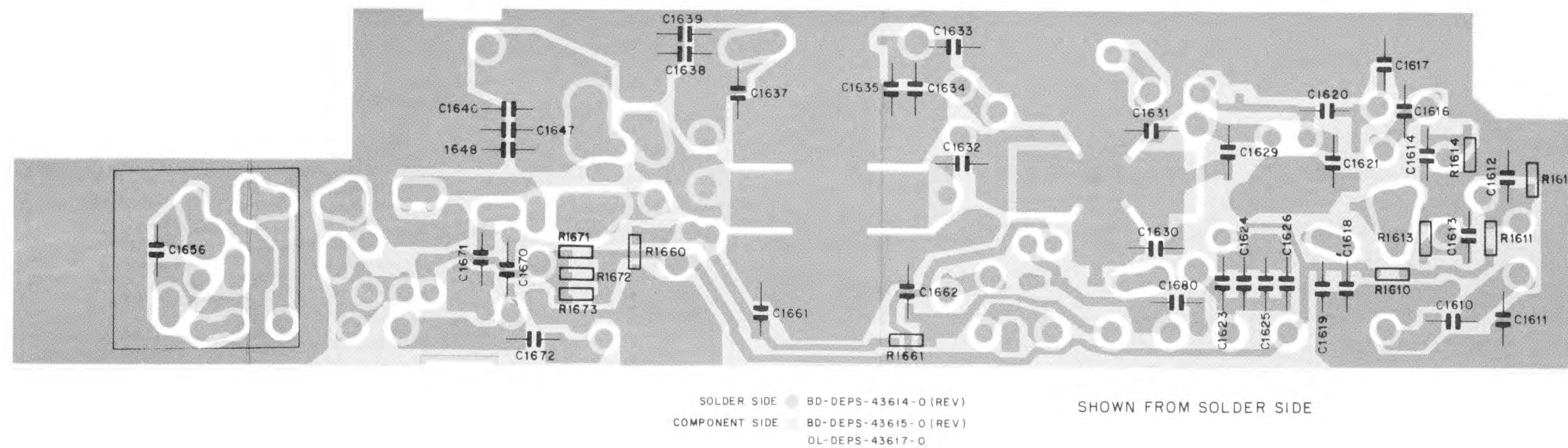

SHOWN FROM SOLDER SIDE

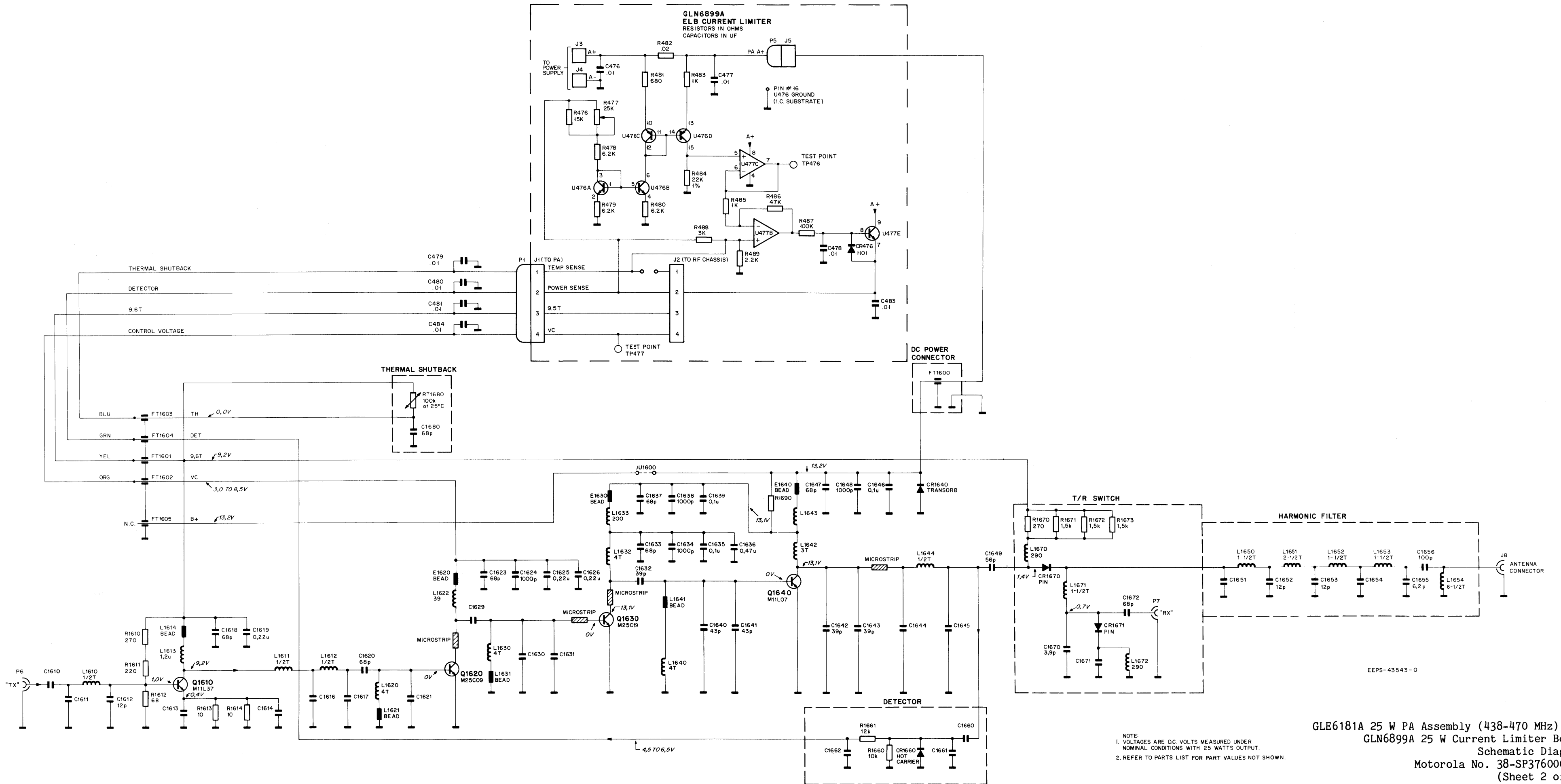

NOTE:
 1. VOLTAGES ARE DC VOLTS MEASURED UNDER NOMINAL CONDITIONS WITH 25 WATTS OUTPUT.
 2. REFER TO PARTS LIST FOR PART VALUES NOT SHOWN.

GLE6181A 25 W PA Assembly (438-470 MHz) and
 GLN6899A 25 W Current Limiter Board
 Schematic Diagram
 Motorola No. 38-SP3760001-1
 (Sheet 2 of 2)
 3/30/87

PARTS LIST

REF SYMBOL	MOTOROLA PART NO.	DESCRIPTION
		<u>CAPACITOR, fixed:</u> uF $\pm 5\%$, 50 V; unless otherwise stated
C1610	21-11031A40	110 pF (GLE6179A)
	21-11031A35	68 pF (GLE6181A)
C1611	21-11031A21	18 pF (GLE6179A)
	21-11031A17	12 pF (GLE6181A)
C1612	21-11031A17	12 pF
C1613	21-11031A40	110 pF (GLE6179A)
	21-11031A37	82 pF (GLE6181A)
C1614	21-11031A40	110 pF (GLE6179A)
	21-11031A37	82 pF (GLE6181A)
C1616	21-11031A11	6.8 pF (GLE6179A)
	21-11031A09	4.7 pF $\pm .25$ pF (GLE6181A)
C1617	21-11031A21	18 pF (GLE6179A)
	21-11031A10	5.6 pF ± 0.5 pF (GLE6181A)
C1618	21-11031A35	68 pF
C1619	21-11032B15	0.22 +80-20%
C1620	21-11031A35	68 pF
C1621	21-11031D15	10 pF ± 0.5 pF (GLE6179A)
	21-11031A10	5.6 pF ± 0.5 pF (GLE6181A)
C1623	21-11031A35	68 pF
C1624	21-11032B01	1000 pF +80-20%
C1625, 1626	21-11032B15	0.22 +80-20%
C1629	21-11031A25	27 pF (GLE6179A)
	21-11031A27	33 pF (GLE6181A)
C1630	21-11031A25	27 pF (GLE6179A)
	21-11031A24	24 pF (GLE6181A)
C1631	21-11031A26	30 pF (GLE6179A)
	21-11031A25	27 pF (GLE6181A)
C1632	21-11033B27	39 pF; 100 V
C1633	21-11031A35	68 pF
C1634	21-11032B01	1000 pF +80-20%
C1635	21-11032B13	0.1 +80-20%
C1636	8-11051A17	0.47; 63 V
C1637	21-11031A35	68 pF
C1638	21-11032B01	1000 pF +80-20%
C1639	21-11032B13	0.1 +80-20%
C1640, 1641	21-11033B28	43 pF; 100 V
C1642	21-11033B27	39 pF; 100 V (GLE6181A)
C1642	21-11033B26	36 pF; 100 V (GLE6179A)
C1643	21-11033B27	39 pF; 100 V
C1644	21-80240G38	22 pF (GLE6179A)
	21-80240G35	15 pF (GLE6181A)
C1645	21-80240G11	6.2 pF (GLE6179A)
	21-82040G13	7.5 pF (GLE6181A)
C1646	21-11032B13	0.1 +80-20%
C1647	21-11031A35	68 pF
C1648	21-11032B01	1000 pF +80-20%

PARTS LIST

REF SYMBOL	MOTOROLA PART NO.	DESCRIPTION
C1649	21-80240G44	56 pF (GLE6179A)
	21-80240G27	56 pF; 250 V (GLE6181A)
C1651	21-80240G17	12 pF (GLE6179A)
	21-80240G16	10 pF (GLE6181A)
C1652, 1653	21-9-24-G18	12 F
C1654	21-82040G15	9.1 pF (GLE6179A)
	21-80240G16	10 pF (GLE6181A)
C1655	21-80240G11	6.2 pF
C1656	21-11033B37	100 pF; 100 V (GLE6179A)
C1660	21-82450B11	3 pF; 500 V (GLE6179A)
	21-82450B18	2 pF; 500 V (GLE6181A)
C1661	21-11033B10	7.5 pF \pm .25 pF; 100 V (GLE6179A)
	21-11033B11	8.2 pF \pm 0.5 pF; 100 V (GLE6181A)
C1662	21-11031A37	82 pF (GLE6179A)
	21-11031A35	68 pF (GLE6181A)
C1670	21-11031A08	3.9 pF \pm .25 pF
C1671	21-11003B20	20 pF; 100 V (GLE6179A)
	21-11033B18	16 pF; 100 V (GLE6181A)
C1672	21-11031A35	68 pF (GLE6179A)
C1680	21-11031A35	68 pF (GLE6179A)
<u>DIODE:</u> (SEE NOTE)		
CR1640	48-82036E07	silicon
CR1660	48-84616A01	hot carrier
CR1670, 1671	48-83510F04	silicon
<u>CORE:</u>		
E1620, 1630, 1640	76-83960B01	ferrite bead
<u>FILTER:</u>		
FT1601 thru 1605	91-87511C01	feed thru
<u>CONNECTOR:</u>		
J8	1-02716B69	assembly coax xmit output; includes:
	9-82442E01	female, single contact
	15-483599	HOOD, receptacle
	30-83794C01	CABLE, coaxial
	43-03423A01	BUSHING, coaxial
<u>COIL, rf:</u>		
L1610, 1611	24-11030E01	1/2 turns (brown)
L1612	24-11030E02	1/2 turn (red) (GLE6179A)
	24-11030E01	1/2 turn (brown) (GLE6181A)
L1613	24-80044F04	choke, 1.2 uH
L1614	24-80036A01	ferrite bead, 1/2 turn
L1620	24-11030A03	4 turns (yellow)
L1621	24-80036A01	ferrite bead, 1/2 turn

PARTS LIST

REF SYMBOL	MOTOROLA PART NO.	DESCRIPTION
L1622	24-82723H44	choke, D39 uH (blue/yellow)
L1630	24-11030A03	4 turns (yellow)
L1631	24-80036A01	ferrite bead, 1/2 turn
L1632	24-11030A03	4 utnrs (yellow)
L1633	24-82723H46	0.4 uH (blue/green)
L1640	24-11030A03	4 turns (yellow)
L1641	24-80036A01	ferrite bead, 1/2 turn
L1642	24-11030A02	3 turns (orange)
L1643	24-84346A02	choke, 0.23 uH
L1644	24-11030E02	1/2 turn (red)
L1650	24-11030B03	1 1/2 turns (orange)
L1651	24-11030B05	2 1/2 turns (green)
L1652	24-11030B02	1 1/2 turns (red)
L1653	24-11030B03	1 1/2 turns (orange)
L1654	24-11030B11	6 1/2 turns (orange)
L1670	24-82723H40	choke, 0.29 uH (yellow-black)
L1671	24-11030B02	1 1/2 turns (red)
L1672	24-82723H40	choke, 0.29 uH (yellow/black)
<u>CONNECTOR, plug:</u>		
P1	15-82694R03	HOUSING, receptacle
	39-82693R02	CONTACT, receptacle crimp snap; 4 used
P5	28-02098M02	male, single contact
P6, 7	30-80116K06	CABLE, coaxial includes: plug
<u>TRANSISTOR: (SEE NOTE)</u>		
Q1610	48-84411L37	NPN; type M11L37
Q1620	48-80225C09	NPN; type M25C09
Q1630	48-80225C19	NPN; type M25C19
Q1640	48-84411L07	NPN; type M11L07
<u>RESISTOR, fixed: ±5%; 1/8 W</u>		
R1610	6-11024A35	270
R1611	6-11024A33	220
R1612	6-11024A21	68
R1613 thru 1615	6-11024A01	10
R1660	6-11024A73	10k
R1661	6-11024A75	12k
R1670	6-02369M29	270; 0.6 W
R1671, 1672	6-11024A53	1.5k
R1773	6-11024A53	1.5k
<u>THERMISTOR:</u>		
RT1680	6-83600K05	100k @ 250°C
<u>MECHANICAL PARTS:</u>		
	2-7003	NUT, 8-32 x 5/16 x 1/8"
	2-7018	NUT, 3/8 x 32 x 1/2 x 3/32"

PARTS LIST

REF SYMBOL	MOTOROLA PART NO.	DESCRIPTION
	3-02607B01	SCREW, taptite M3 x 8 mm; 9 used
	3-02607B02	SCREW, taptite M3 x 6 mm; 4 used
	26-80222H01	HEAT SINK
	26-80199J01	SHIELD, filter
	3-80165J07	SCREW, machine; M4 x 10 mm
	3-80269H09	SCREW, tapt M5 x 0.8 mm; 2 used
	4-7691	LOCKWASHER; 3/8" internal
	7-03432A01	BRACKET
	9-80038K02	CONNECTOR, power
	15-03424A01	COVER, PA
	26-80092K01	SHIELD, antenna
	26-80176H08	HEAT SINK
	29-5318	LUG, solder cap; 2 used
	30-80116K06	CABLE, coaxial
	42-80201J01	CLIP, ground
	42-82405R01	CLIP
	9-82442E01	CONNECTOR
	15-483599	HOOD, receptacle
	30-83794C01	CABLE, coaxial (white)
	43-03423A01	BUSH, coaxial
	39-82693R02	CONTACT, contact crimp snap; 4 used
	42-10217A02	STRAP, tie: .091 x 3.62"; 2 used

NOTE: For optimum performance, diodes, transistors, crystals and integrated circuits must be ordered by Motorola part numbers.

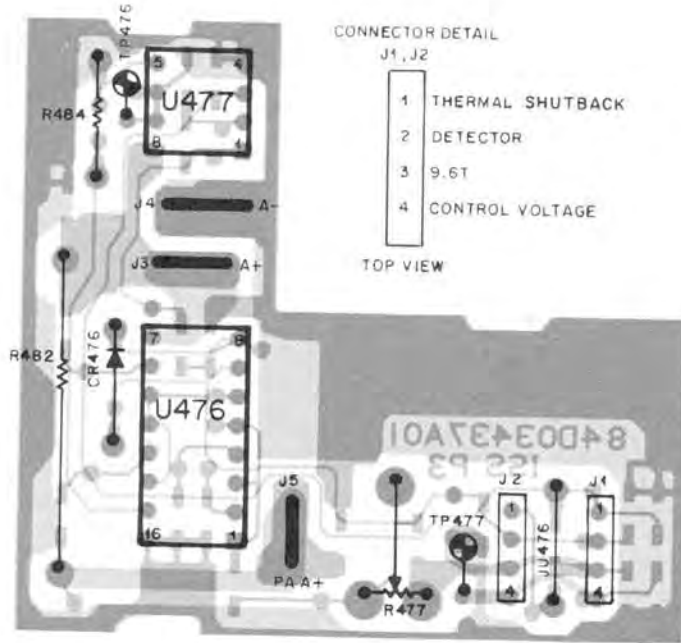

COMPONENT SIDE ● BD-BEPS-43509-0
 SOLDER SIDE ● BD-BEPS-43510-0 ● OL-BEPS-43511-0

SHOWN FROM COMPONENT SIDE

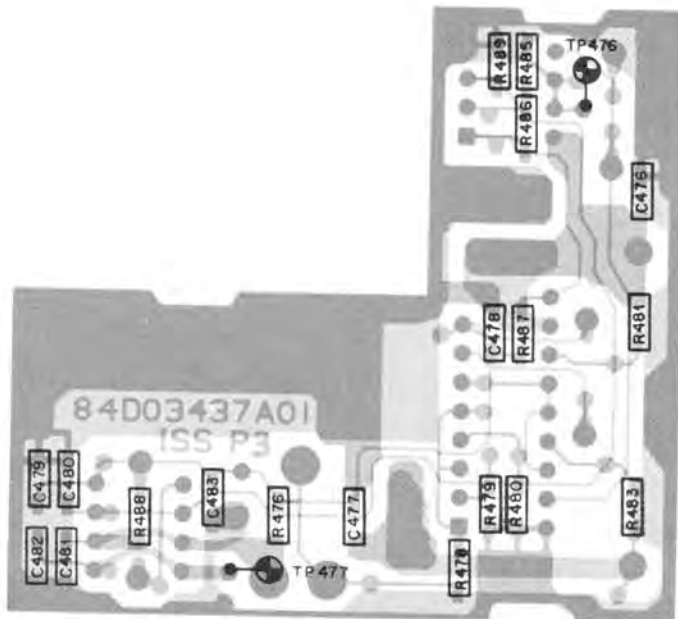

COMPONENT SIDE ● BD-BEPS-43509-0 (REV)
 SOLDER SIDE ● BD-BEPS-43510-0 (REV) ● OL-BEPS-43512-0

SHOWN FROM SOLDER SIDE

PARTS LIST

REF SYMBOL	MOTOROLA PART NO.	DESCRIPTION
C476 thru 483	21-11032A21	<u>CAPACITOR, fixed:</u> uF $\pm 10\%$; 50 V .01 (chip)
CR476	48-83654H01	<u>DIODE:</u> (SEE NOTE) silicon
J1	28-82697R03	<u>CONNECTOR, receptacle:</u> male, 4 position
J2	28-82697R03	HDR PLUG 4 POSTN STRA
J3 thru 5	29-10231A10	TERM BRS
R476	6-11024A77	<u>RESISTOR, fixed:</u> chip $\pm 5\%$; 1/8 W 15k
R477	18-02099B02	variable 25k
R478 thru 480	6-11024A68	6200
R481	6-11024A45	680
R482	17-82620B03	FWW .02 5 3 W
R483	6-11024A49	1000, 5 1/8
R484	6-02366M81	FMF 22k, 1%; .39 W
R485	6-11024A49	1000
R486	6-11024A89	47k
R487	6-11024A97	100k
R488	6-11024A60	3000
R489	6-11024A57	2200
TP476, 477	28-02002M15	<u>TEST POINT:</u> male, single contact
U476	51-84320A79	<u>INTEGRATED CIRCUIT:</u> (SEE NOTE) amplifier diff/prec
U477	51-82609M33	dual operational amplifier

NOTE: For optimum performance, diodes, transistors, crystals and integrated circuits must be ordered by Motorola part numbers.

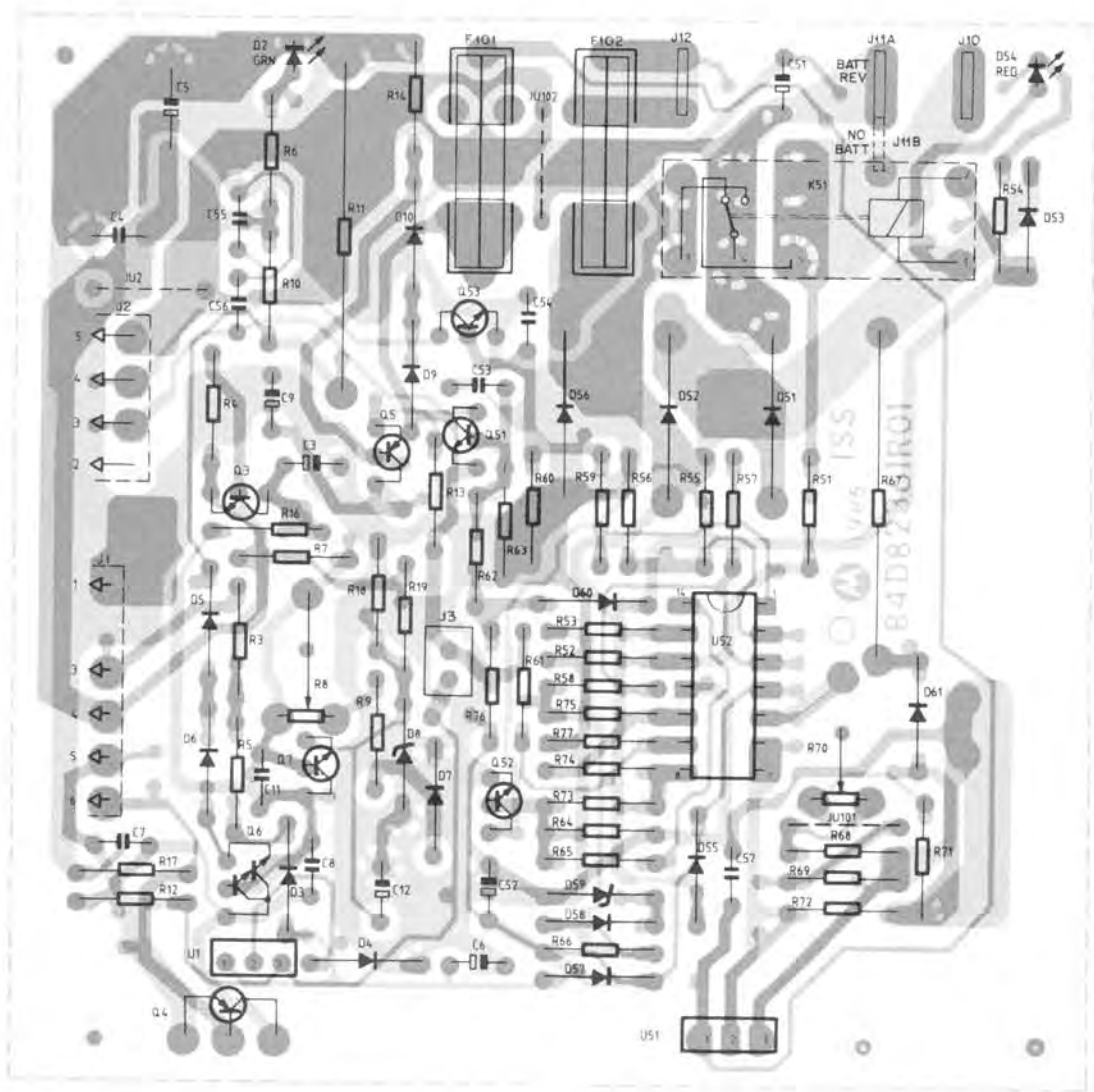

COMPONENT SIDE - BD-DEPS-43518-0
 SOLDER SIDE - BD-DEPS-43519-0 SHOWN FROM SOLDER SIDE
 OL-DEPS-43520-0

GLN6780A Battery Revert Regulator Board
 p/o GPN1009A, Battery Revert Power Supply
 Circuit Board Detail
 Motorola No. 41-SP3760001-1
 (Sheet 1 of 2)
 3/30/87

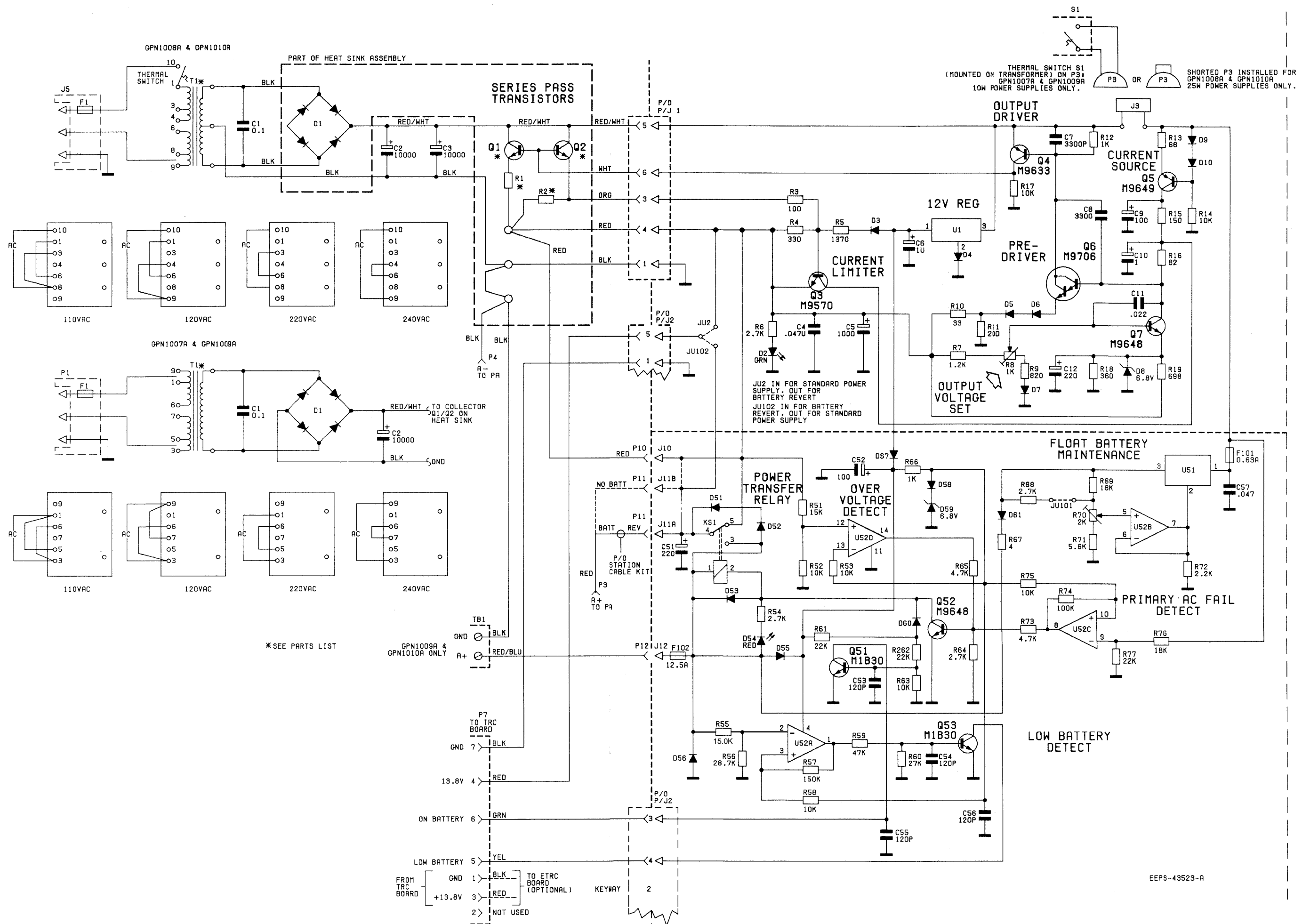

THERMAL SWITCH S1 (MOUNTED ON TRANSFORMER) ON P3; GPN1007A & GPN1009A 10W POWER SUPPLIES ONLY. SHORTED P3 INSTALLED FOR GPN1008A & GPN1010A 25W POWER SUPPLIES ONLY.

NOTES:
1. UNLESS OTHERWISE SPECIFIED, ALL RESISTOR VALUES ARE IN OHMS AND ALL CAPACITORS ARE IN MICROFARADS.

* SEE PARTS LIST

GPN1008A & GPN1010A (BATTERY REVERT) ONLY

EEPS-43523-A

GPN1009A, 10A Battery Revert Power Supply
Schematic Diagram
Motorola No. 41-SP3760001-1
(Sheet 2 of 2)
3/30/87

PARTS LIST

REF SYMBOL	MOTOROLA PART NO.	DESCRIPTION
		<u>CAPACITOR, fixed:</u> uF unless otherwise stated
C4	21-02288M13	.047 ±10%; X7R
C5	23-60561B25	1000 ±20%; 25 V
C6	23-11048B05	1 ±20%; 50 V
C7, 8	21-02288M04	3300 pF ±10%; X7R
C9	23-11019A46	100 ±10%; 25 V
C10	23-11048B05	1 ±20%; 50 V
C11	21-02288M11	.022 ±10%; X7R
C12	23-60561B21	220 ±20%; 25 V
C51	23-60561B21	220 ±20%; 25 V
C52	23-11019A46	100 ±20%; 25 V
C53 thru 56	21-02281M08	120 pF ±5%; NPO
C57	21-02288M13	.047 ±10%; X7R
		<u>DIODE:</u> (SEE NOTE)
D2	48-80058K02	green
D3 thru 7	48-83654H01	silicon
D8	48-82256C47	Zener type; 6.8 V
D9, 10	48-83654H01	silicon
D51, 52	48-08085B01	silicon
D53	48-82466H13	silicon
D54	48-80058K01	red
D55	48-83654H01	silicon
D56	48-08085B01	silicon
D57, 58	48-83654H01	silicon
D59	48-82256C47	Zener type; 6.8 V
D60	48-83654H01	silicon
D61	48-82466H13	silicon
		<u>FUSE:</u>
F101	65-84711C19	0.63 amp
F102	65-84711C20	12.5 amp
		<u>CONNECTOR, receptacle:</u>
J1	28-82984N13	male, 6-contact
J2	28-83441F04	male, 5-contact (red)
J3	28-80184B04	male, 2-contact
J10 thru 12	29-10231A10	terminal, single contact
		<u>JUMPER:</u>
JU2	6-11009D23	0 ohm res.
JU102	6-11009D23	0 ohm res.
		<u>RELAY:</u>
K51	80-02111M02	12 volts, 50 ma.

PARTS LIST

REF SYMBOL	MOTOROLA PART NO.	DESCRIPTION
		<u>TRANSISTOR:</u> (SEE NOTE)
Q3	48-869570	NPN; type M9570
Q4	48-869633	PNP; type M9633
Q5	48-869649	PNP; type M9649
Q6	48-869706	NPN; Darlington type M9706
Q7	48-869648	NPN; type M9648
Q51	48-02081B30	NPN; type M1B30
Q52, 53	48-869648	NPN; type M9648
		<u>RESISTOR, fixed:</u> $\pm 5\%$; 0.6 W; unless otherwise stated
R3	6-02366M25	100 $\pm 1\%$; 0.39 W
R4	6-02366M37	330 $\pm 1\%$; 0.39 W
R5	6-11049J08	1370 $\pm 1\%$; 1/4 W
R6	6-02369M42	2.7k
R7	6-02369M38	1.2k
R8	18-02099B11	variable; 1k $\pm 20\%$
R9	6-02369M36	820
R10	6-02369M19	33
R11	17-84820A07	W.W. 200
R12	6-02369M37	1k
R13	6-02369M23	68
R14	6-02369M49	10k
R15	6-02369M27	150
R16	6-02369M24	82
R17	6-02369M49	10k
R18	6-02366M38	360 $\pm 1\%$; 0.39 W
R19	6-11049H79	698 $\pm 1\%$; 1/4 W
R51	6-02369M51	15k
R52, 53	6-02369M49	10k
R54	6-02369M42	2.7k
R55	6-02366M77	15k $\pm 1\%$; 0.39 W
R56	6-11049K36	28.7k $\pm 1\%$; 1/4 W
R57	6-02369M63	150k
R58	6-02369M49	10k
R59	6-02369M57	47k
R60	6-02369M54	27k
R61, 62	6-02369M53	22k
R63	6-02369M49	10k
R64	6-02369M42	2.7k
R65	6-02369M45	4.7k
R66	6-02369M37	1k
R67	17-82177B03	W.W. 4 $\pm 10\%$; 5 W
R68	6-02369M42	2.7k
R69	6-02369M52	18k
R70	18-02099B01	variable; 2k
R71	6-02369M46	5.6k
R72	6-02369M41	2.2k

PARTS LIST

REF SYMBOL	MOTOROLA PART NO.	DESCRIPTION
R73	6-02369M45	4.7k
R74	6-02369M61	100k
R75	6-02369M49	10k
R76	6-02369M52	18k
R77	6-02369M53	22k
S1 Supply only)	1-02716B38	<u>SWITCH:</u> assembly, thermal (p/o P3 on 10 W Power
U1	51-83629M94	<u>INTEGRATED CIRCUIT:</u> (SEE NOTE) 12 V regulator
U51	51-84621K96	voltage regulator
U52	51-83629M18	quad operational amplifier
	9-02263B01	<u>MECHANICAL PARTS:</u> CLIP, fuseholder; 4 used

NOTE: For optimum performance, diodes, transistors, crystals and integrated circuits must be ordered by Motorola part numbers.

PARTS LIST

REF SYMBOL	MOTOROLA PART NO.	DESCRIPTION
		<u>CAPACITOR, fixed:</u> unless otherwise stated
C1	8-84700C01	0.1 uF ±10%; 250 V
C2	23-84818A02	10000 uF +50-10%; 40 V
		<u>DIODE:</u> (SEE NOTE)
D1	48-02081B06	bridge, rectifier
		<u>FUSE:</u>
F1	65-84711C10	1.6 amp; 220/230/240 V
		<u>CONNECTOR, receptacle:</u>
J3	28-80181B04	male; 2-contact
J5	28-02138M04	female; ac mains socket w/fuseholder (F1)
		<u>CONNECTOR, plug:</u>
P1	15-83498F37	housing, 6-position
	29-83499F01	terminal; 5 used
P2	15-83498F04	housing, 5-position
	29-83499F01	terminal; 4 used
P3	14-84277D25	housing, 2-position
	9-80257H01	lug, crimp-on; 2 used
P4	28-02098M02	female; single contact
P7	15-83498F15	housing, 7-position
	29-83499F01	terminal, lug; 4 used
P10 thru 12	28-02098M02	female; single contact
		<u>TRANSISTOR:</u> (SEE NOTE)
Q1, 2	48-02081B29	NPN; type M1B29
		<u>RESISTOR, fixed:</u>
R1, 2	17-84820A06	0.2 ±5%; 7 W
		<u>SWITCH:</u>
S1	1-02716B38	thermal, assembly: includes P3
		<u>TRANSFORMER:</u>
T1	25-02488M01	power; 10 watt
		<u>MECHANICAL PARTS:</u>
	2-84719C01	NUT, hex; M5 MM
	2-84784B05	NUT, hex M3 mm; 3 used
	3-08634B25	SCREW, M5 x 16 mm
	3-80165J07	SCREW, machine: M4 x 10 mm; 4 used
	3-80269H06	SCREW, tapt: M3 x 0.5 mm; 2 used
	3-80269H07	SCREW, tapt: M4 x 0.7 mm; 5 used
	3-80269H08	SCREW, tapt; M3 x 0.5 mm; 3 used
	3-84722C31	SCREW, M4 x 55 mm; 4 used

PARTS LIST

REF SYMBOL	MOTOROLA PART NO.	DESCRIPTION
	3-84723C29	SCREW, M3 x 4 mm
	3-84893D02	BOLT, M4 x 25 mm w/internal thread; 4 used
	4-135069	WASHER, flat: .172 x .375 x .036"; 3 used
	4-84717C24	WASHER, flat; 3 used
	4-84718C02	LOCKWASHER, A 4.3 mm; 8 used
	4-84718C04	LOCKWASHER, A 3.2 mm; 3 used
	4-84718C10	LOCKWASHER, A 5.1 mm
	5-02157B07	RIVET, blind; 2 used
	9-02088M01	SOCKET, transistor; 2 used
	14-02161M01	INSULATOR; 2 used
	14-02309M01	INSULATOR, cap; 2 used
	14-03440A01	INSULATOR, AC line
	15-03433A01	COVER, battery connector
	15-82120R01	HOUSING, radio
	26-82152R01	HEAT SINK
	31-122068	TERMINAL, strip; 3 insulated #4 mount
	42-02211B01	CLAMP
	42-02228M01	RETAINER, switch
	42-10217A02	STRAP, tie: .091 x 3.62"; 16 used
	46-84203E01	GUIDE
	54-02335M01	LABEL
	14-84277D25	HOUSING, connector
	15-82694R01	HOUSING, connector; 2 position
	43-84798F01	INSERT, polarizing key; 3 used

NOTE: For optimum performance, diodes, transistors, crystals and integrated circuits must be ordered by Motorola part numbers.

PARTS LIST

REF SYMBOL	MOTOROLA PART NO.	DESCRIPTION
		<u>CAPACITOR, fixed:</u> unless otherwise stated
C1	8-84700C01	0.1 uF ±10%; 250 V
C2, 3	23-84818A02	10000 uF +50-10%; 40 V
		<u>DIODE:</u> (SEE NOTE)
D1	48-02081B20	bridge, rectifier
		<u>FUSE:</u>
F1	65-84711C11	3.16 amp; 110/220 V
		<u>CONNECTOR, receptacle:</u>
J3	28-80181B04	male; 2-contact
J5	28-02138M04	female; ac mains socket w/fuseholder (F1)
		<u>CONNECTOR, plug:</u>
P1	15-83498F37	housing, 6-position
	29-83499F01	terminal; 5 used
P2	15-83498F04	housing, 5-position
	29-83499F01	terminal; 4 used
P3	14-84277D25	housing, 2-position
	9-80257H01	lug, crimp-on; 2 used
P4	28-02098M02	female; single contact
P7	15-83498F15	housing, 7-position
	29-83499F01	terminal, lug; 4 used
P10 thru 12	28-02098M02	female; single contact
		<u>TRANSISTOR:</u> (SEE NOTE)
Q1, 2	48-869639	NPN; type M9639
		<u>RESISTOR, fixed:</u>
R1, 2	17-84820A05	0.1 ±5%; 7 W
		<u>TRANSFORMER:</u>
T1	25-82169R01	power; 25 watt
		<u>MECHANICAL PARTS:</u>
	2-84719C01	NUT, hex; M5 MM
	2-84784B05	NUT, hex M3 mm; 3 used
	3-08634B25	SCREW, M5 x 16 mm
	3-80165J07	SCREW, machine: M4 x 10 mm; 4 used
	3-80165J09	SCREW, machine: M4 x 0.7 mm; 4 used
	3-80269H06	SCREW, tapt: M3 x 0.5 mm; 2 used
	3-80269H07	SCREW, tapt: M4 x 0.7 mm; 5 used
	3-80269H08	SCREW, tapt; M3 x 0.5 mm; 3 used

PARTS LIST

REF SYMBOL	MOTOROLA PART NO.	DESCRIPTION
	3-84723C16	SCREW, M3 x 25 mm; 4 used
	3-84722C31	SCREW, M4 x 55 mm; 4 used
	3-84723C29	SCREW, M3 x 4 mm
	3-84893D02	BOLT, M4 x 25 mm w/internal thread; 4 used
	4-135069	WASHER, flat: .172 x .375 x .036"; 4 used
	4-84717C24	WASHER, flat; 3 used
	4-84718C02	LOCKWASHER, A 4.3 mm; 8 used
	4-84718C04	LOCKWASHER, A 3.2 mm; 3 used
	4-84718C10	LOCKWASHER, A 5.1 mm
	5-02157B07	RIVET, blind; 4 used
	9-02088M01	SOCKET, transistor; 2 used
	14-02161M01	INSULATOR; 2 used
	14-02309M01	INSULATOR, cap; 2 used
	14-03440A01	INSULATOR, AC line
	15-03433A01	COVER, battery connector
	15-82120R01	HOUSING, radio
	26-82152R01	HEAT SINK
	31-122068	TERMINAL, strip; 3 insulated #4 mount
	42-02211B01	CLAMP; 2 used
	42-02228M01	RETAINER, switch
	42-10217A02	STRAP, tie: .091 x 3.62"; 17 used
	46-84203E01	GUIDE; 2 used
	54-02335M01	LABEL
	14-84277D25	HOUSING, connector
	15-82694R01	HOUSING, connector; 2 position
	43-84798F01	INSERT, polarizing key; 3 used

NOTE: For optimum performance, diodes, transistors, crystals and integrated circuits must be ordered by Motorola part numbers.

END OF DOCUMENT