

 **MOTOROLA**  
test equipment

**"DIGITAL PRIVATE-LINE"  
TEST SET**

**SLN-6413A**



THIS DOCUMENT HAS BEEN  
**DISCONTINUED**

68P81069A30-A

# MOTOROLA

## "DIGITAL PRIVATE-LINE" TEST SET

MODEL SLN-6413A

### CONTENTS

Specifications . . . . .	ii
Foreword . . . . .	ii & iv
 INTRODUCTION . . . . .	 1
UNPACKING AND REPACKING . . . . .	1
Unpacking . . . . .	1
Repacking . . . . .	1
 POWER REQUIREMENTS . . . . .	 1
CONTROLS, INDICATORS AND CONNECTORS . . . . .	2
Front Panel . . . . .	2
Rear Panel . . . . .	2
 INITIAL SET - UP AND OPERATIONAL CHECKOUT . . . . .	 2
THEORY OF OPERATION . . . . .	4
Introduction . . . . .	4
General . . . . .	4
Encoder . . . . .	4
Decoder . . . . .	4
Power Supply . . . . .	6
Clock . . . . .	6
 TEST AND TROUBLESHOOTING PROCEDURES . . . . .	 6
Testing a Code Plug . . . . .	6
Testing an Encoder (In a Radio) . . . . .	6
Testing a Decoder (In a Radio) . . . . .	6
 MAINTENANCE . . . . .	 8
Case Removal/Assembly . . . . .	8
Removal and Replacement of Main Encoder-Decoder Board . . . . .	8
Removal and Replacement of RFI Filter Board . . . . .	9
Output Waveform Test . . . . .	9
Code Input Sensitivity Test . . . . .	9
 PARTS LIST . . . . .	 10
 SCHEMATIC DIAGRAM & CIRCUIT BOARD DETAIL . . . . .	 12 & 13



**MOTOROLA INC.**

ENGINEERING PUBLICATIONS

1301 E. ALGONQUIN ROAD

**Communications Division**

SCHAUMBURG, ILLINOIS 60172

## SPECIFICATIONS

AC LINE INPUT	105-130, 210-240 V ac; 50-60 Hz
DC INPUT	10.8-15.0 V dc
SIZE	8" wide x 4-1/8" high x 9-1/2" deep
WEIGHT	Less than three pounds
ENCODING SECTION	
Output Level	0 to 3 V p-p variable, ac coupled, into 600-ohm load.
Output Impedance	Approximately 100 ohms
Output Code	000 to 777 (octal)
Code Generation	By thumbwheel switches or code plug with polarity inversion capability
DECODING SECTION	
Input Sensitivity	25 mV p-p
Input Frequency Response	Attenuates 10 dB per octave above 140 Hz
Input Code	000 to 777 (octal)
Code Comparison	Against thumbwheel switches or code plug, with polarity inversion capability
DECODE Detect Light	Turns on when code in matches code plug inserted in socket, or code dialed by thumbwheel switches.

SPECIFICATIONS SUBJECT TO CHANGE WITHOUT NOTICE.

## 1. INTRODUCTION

1.1 The Motorola Model SLN-6413A "Digital Private-Line" Test Set is the major item of test equipment needed for servicing "Digital Private-Line" encoders and decoders in Motorola radios equipped for binary-coded squelch operation. The test set generates and decodes any possible "Digital Private-Line" code word; thus it simulates one of the other radio sets in the "Digital Private-Line" network and permits testing without the use of the network's other radios. The test set may be used for testing all types of Motorola "Digital Private-Line" radios.

1.2 The test set contains a separate "Digital Private-Line" encoder and decoder, and both may be used simultaneously if necessary. Thumbwheels on the front panel allow any possible code word to be programmed into the test set. Additionally, separate code plug sockets are provided for both the encoder and decoder sections of the test set so that code plugs can be used to program the code word into the test set or code plugs can be tested.

1.3 The test set can be used for both signal substitution and signal tracing methods of troubleshooting. The test set encoder generates any possible "Digital Private-Line" code word for injection into the equipment being tested. A PTT switch on the test set places the encoder into the transmit mode whenever desired, and can be locked in the transmit mode for continuous code generation. A level control adjusts the output signal level.

1.4 The test set decoder gives a visual indication if the point of measurement contains the proper code word signal, and can thus be used for many signal tracing measurements.

1.5 Front panel switches allow the encoder output signal and decoder input signal to be inverted, if necessary, to match the signal polarity required by the equipment under tests.

1.6 The test set operates from 120 or 230 volt ac power for bench testing. It also operates from 12 volt dc power which is a convenience when servicing radios in a vehicle.

## 2. UNPACKING AND REPACKING

### 2.1 UNPACKING

The test set has been carefully inspected and thoroughly tested before shipment from the

factory. Upon receipt of the packaged unit, inspect the shipping carton and equipment for damage. Report any visible damage to the local carrier for corrective action. Check the overall contents of the package against the shipping invoice or bill of materials.

### 2.2 REPACKING

If for any reason it is necessary to reship the test set, repackage the unit in its original shipping carton. If the original shipping carton is not available, wrap the instrument in heavy paper or plastic and use cardboard around the front panel to protect the controls. Pack and seal inside a sturdy box with at least 2" of packing material on all sides. Pack this container in a larger box and seal with fiber reinforced tape or metal bands. On the outside mark "FRAGILE, DELICATE INSTRUMENT".

If the instrument is being returned for repair or service, attach a tag identifying the owner, model number, full serial number, and describe trouble symptoms or complaint.

## 3. POWER REQUIREMENTS

3.1 The test set is normally wired to operate on 120 V ac, 50-60 Hz or a fully charged auto-type (13.6 V) battery. A switch on the rear panel switches from ac to dc operation. A fuse is provided in each circuit.

3.2 The power transformer primaries can be rewired in series to convert to 230 V ac. To do this, remove the jumper from terminals 0 to M on the RFI filter board. Unsolder green wire from power transformer at terminal N and move it to terminal M. Replace 1/2 A fuse with 1/4 A fuse supplied and place new label over old label.

### WARNING

The power supply is shipped with a 3-wire ac power cable. DO NOT disconnect the third wire ground on this cable. This would create a serious electrical shock hazard. If a 2-wire to 3-wire adapter is used, be sure the adapter provides a good earth ground.

3.3 A socket that mates with the dc plug is supplied with the test set. The technician can make up his own dc power cable as required. The large terminal on the dc plug is positive. A diode in the input circuit protects against accidental reverse polarity. A dc power cable terminated in a plug that mates with an automobile

cigar lighter may be convenient if servicing in vehicles is anticipated.

#### 4. CONTROLS, INDICATORS, AND CONNECTORS

##### 4.1 FRONT PANEL (See Figure 1)

(1) LEVEL potentiometer - Varies amplitude of encode output.

(2) CODE OUT jack -- Encode section output signal.

(3) INVERTED-NORMAL switch -- Inverts encode section output signal.

(4) Code plug sockets -- Used for encode section. The smaller socket with a staggered pin arrangement accepts code plugs from portable radios. The larger socket with the in-line pin arrangement accepts code plugs from mobile and base station radios.

(5) PTT switch -- When operated either in MOMT (momentary) or CONT (continuous) position, starts transmission of the code selected by the thumbwheel switches, or from the code plug inserted in the encode socket. The switch latches in the CONT position but, in the MOMT position, it returns to off when released. In the center (off) position, a 134 Hz turn-off code is generated.

(6) POWER indicator (red) -- Illuminates when power is on.

(7) POWER switch -- Turns power on if AC-DC PWR switch on rear panel is in proper position.

(8) INVERTED-NORMAL switch -- Inverts decode section input signal.

(9) CODE IN jack -- Decode section input signal.

(10) DECODE indicator -- When illuminated (green) it indicates that "code in" is the same as the code selected by the thumbwheel switches or by the code plug inserted in the decode (right) socket.

(11) Code plug sockets -- Used for decode section. Accepts both type of code plugs as explained for item (4).

(12) DECODE SELECT switch -- Left position connects decode circuits to thumbwheel switches. Right position connects the decode circuits to code plug socket.

(13) Thumbwheel switches 1, 2 and 3 -- Selects code to be tested.

(14) ENCODE SELECT switch -- Left position connects encode circuits to code plug. Right position connects the encode circuits to thumbwheel switches.

##### 4.2 REAR PANEL (see Figure 2)

(1) AC-DC PWR switch -- Used to switch from ac power to dc battery power.

(2) AC socket -- Three prong male jack for ac line cord.

(3) AC fuse -- In series with ac line and primary of power transformer (120 V 1/2 A, 230 V 1/4 A).

(4) DC plug -- Male 2-prong battery input (large is positive).

(5) DC fuse -- In series with positive side of dc battery circuit (1/4 ampere).

#### 5. INITIAL SET-UP AND OPERATIONAL CHECKOUT

This procedure checks proper operation of the test set and should be performed when the unit is first placed in service, before testing any radio sets. The procedure also familiarizes the operator with the use of the controls.

Step 1. Initially set the controls as follows:

LEVEL control - mid position

ENCODE SELECT switch - right position (toward thumbwheels)

DECODE SELECT switch - left position (toward thumbwheels)

PTT switch - off (center)

INVERTED-NORMAL switches - Normal position (both switches)

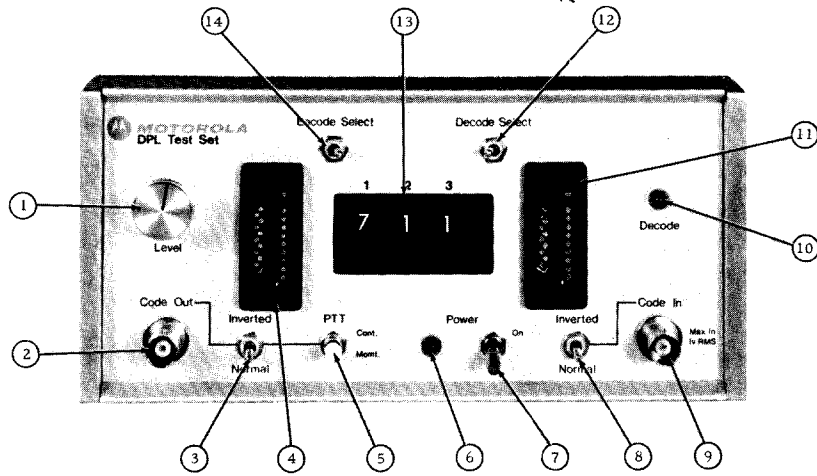

FAEPS-19282-0

Figure 1. Front Panel Operator's Facilities

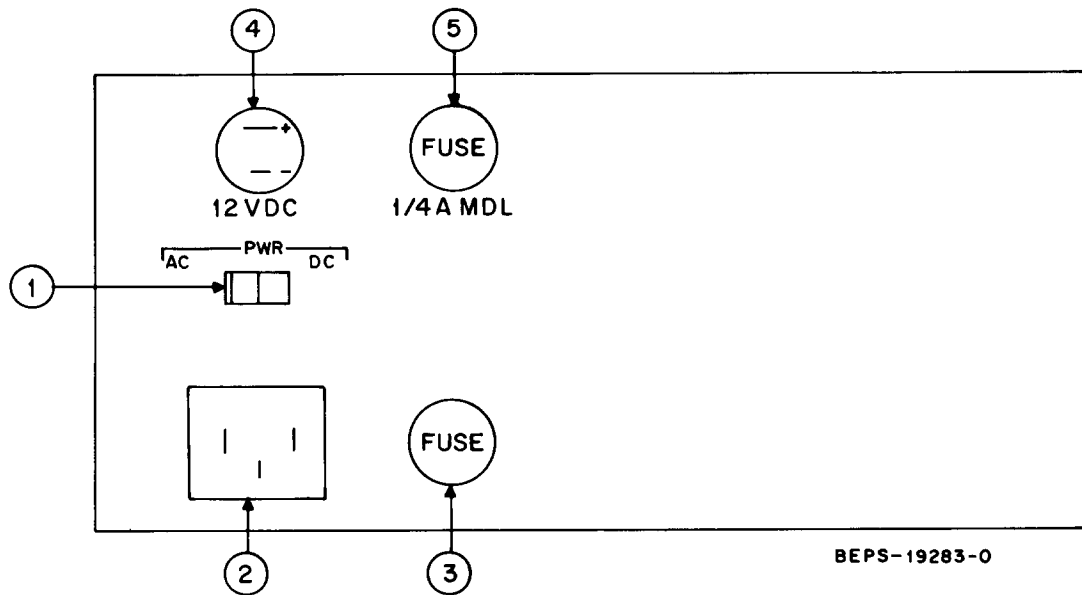

BEPS-19283-0

Figure 2. Rear Panel Operator's Facilities

Step 2. Connect power cord and set AC-DC PWR switch to AC. Turn POWER switch ON. POWER indicator should illuminate.

Step 3. Connect oscilloscope vertical input to CODE OUT jack. Turn-off code (134 Hz sine wave) should be present. Operate PTT switch to both positions and observe pulse train on oscilloscope.

Step 4. Disconnect oscilloscope. Connect CODE OUT jack to CODE IN jack. DECODE light should be off. Set PTT switch to MOMT. DECODE light should go on.

Step 5. Set PTT switch to CONT. Set ENCODE polarity switch to INVERTED. DECODE light should go off.

Step 6. Set DECODE polarity switch to INVERTED. DECODE light should go on. Set PTT switch to center position.

Step 7. Insert a code plug into decode code plug socket. Set DECODE SELECT switch to right position. Dial in code plug's number on thumbwheel switches. Place PTT switch in MOMT position. DECODE lamp should go on.

Step 8. Return DECODE SELECT switch to left position. Set ENCODE SELECT switch to left position. Insert a code plug into encode code plug socket. Dial in code plug's number with thumbwheel switches. Place PTT switch in MOMT position. DECODE lamp should go on.

## 6. THEORY OF OPERATION

(Refer to block diagram, Figure 3, and the schematic diagram at the end of this instruction manual.)

### 6.1 INTRODUCTION

The fundamentals of "Digital Private-Line" system operation and circuit operation are presented in a separate Motorola instruction manual entitled "Digital Private-Line Binary-Coded Squelch" (Motorola Part No. 68P81106E83). Although that document is intended for "Digital Private-Line" radio sets, many of the fundamentals may be helpful in analyzing circuit operation of the test set.

### 6.2 GENERAL

The test set circuitry has separate encode and decode sections and a universal power supply. Both sections can operate simultaneously and can use either a code plug or thumbwheel dial switches as a code source. There are three thumbwheel switches with a dial which indicates the code set into the switches.

### 6.3 ENCODER

6.3.1 The code can be generated by the thumbwheel switches or a code plug. ENCODE SELECT switch S207 selects the thumbwheel or code plug as desired. Integrated circuits U1 and U2 act as a multiplexer which presents only one set of outputs to logic integrated circuit U12.

6.3.2 The thumbwheel switches are based on the octal (base 8) number system. They are derived from a digital word by a straight-forward process. The octal number (or word) is broken into groups of threes, such as 001 011 010. Each group represents an octal number. In this case, 001 is 1, 011 is 3 and 010 is 2, so the octal word is 132. This would be the number stamped on the code plug. If 132 is selected by the thumbwheel switches, the nine outputs of the multiplexer show a digital word 001 011 010.

6.3.3 When PTT switch S204 is operated, U12 generates a 12 bit serial code and 11 parity bits. Nine of the 12 serial bits are variable and three are fixed. The nine variable bits represent the code as explained above.

6.3.4 The logic signal is inverted by Q11 and applied to the low pass filter which attenuates all signals above 140 Hz. Q12 is bypassed if the INVERTED-NORMAL switch is in the NORMAL position.

6.3.5 The desired signal amplitude is adjusted by LEVEL control R201. From drivers Q1 and Q2, the signal passes through C1 to the CODE OUT connector on the front panel.

6.3.6 When the PTT switch is released, code generation is stopped and a 134 Hz turn-off code is generated.

### 6.4 DECODER

6.4.1 Like the encoder, the decoder section can use either the code plug or

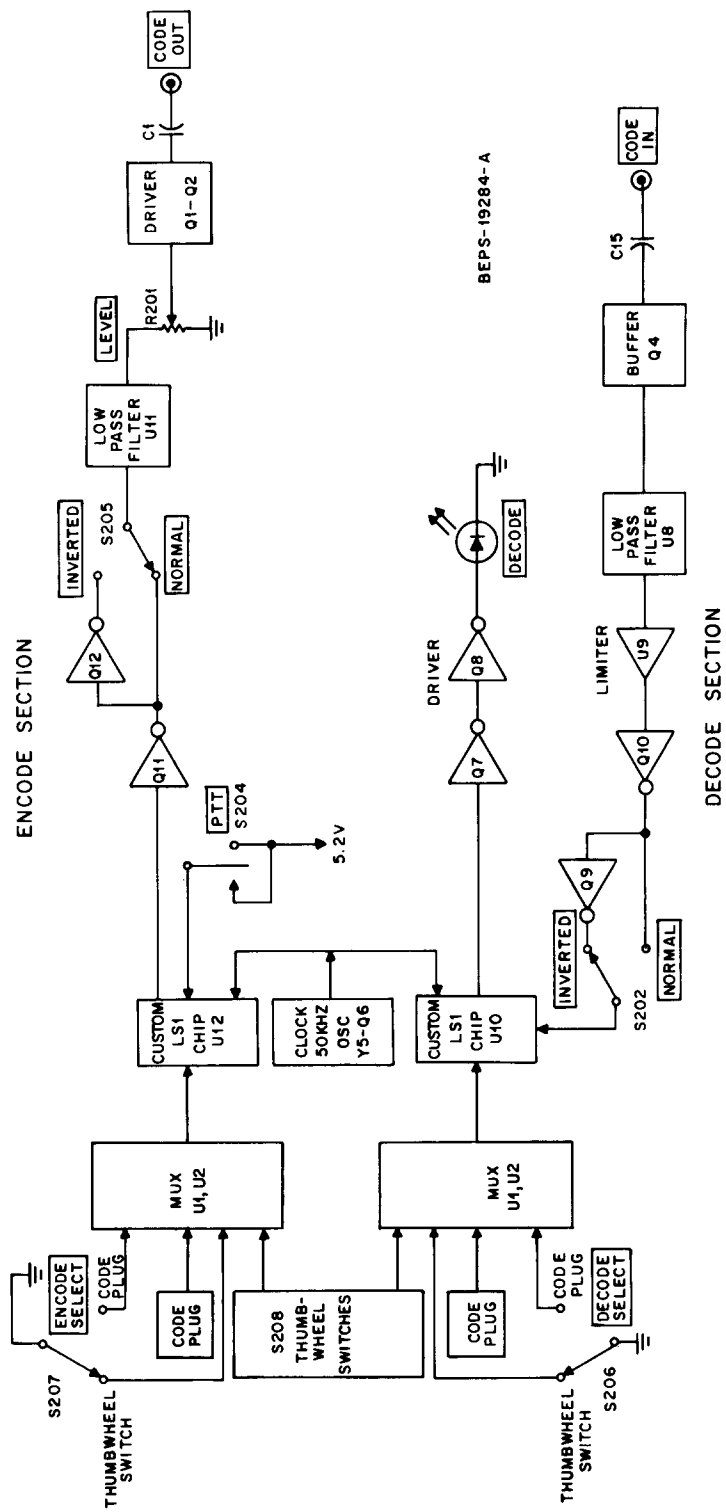

Figure 3. "Digital Private-Line" Test Set Block Diagram

thumbwheel switches as a source. The selection is made by the DECODE SELECT toggle switch S206.

6.4.2 The input code is applied to the CODE IN jack. Buffer Q4 offers a high input impedance to reduce loading by the test set. A low pass active filter (U8) permits the passage of frequencies lower than 140 Hz and attenuates all higher frequencies. The signal is limited by an operational amplifier (U9) set for maximum gain. A level converter (Q10) changes the operational amplifier output to the normal logic input levels. Inverter Q9 is bypassed when the DECODE INVERTED-NORMAL switch is in the NORMAL position.

6.4.3 When the input code matches the reference code (from thumbwheel setting or code plug), integrated circuit U10 generates a decode signal which drives Q7-Q8 and turns on the DECODE light emitting diode.

## 6.5 POWER SUPPLY

6.5.1 The RFI filter circuit, preceding the transformer, filters out line noises. Diodes CR3 and CR4, capacitor C4 and power transformer T201 comprise the full wave rectifier circuit. The rectified voltage is regulated by Q3 and Zener diode CR5, resulting in an output voltage of approximately 13.6 volts. Zener diode CR6 provides the regulated 5.2 volts needed to operate the logic integrated circuits.

6.5.2 The dc circuit consists of a line filter, fuse and diode CR101. Diode CR101 causes fuse F202 to blow if reverse polarity is applied.

## 6.6 CLOCK

The 50 kHz oscillator circuit is comprised of crystal Y5, transistor Q6, and two inverting stages inside integrated circuit U10. The inverters within U10 provide the necessary amplification to drive crystal Y5. Transistor Q6 is a high impedance buffer stage.

## 7. TEST AND TROUBLESHOOTING PROCEDURES

This section should be used as a general guide. Refer to the troubleshooting section of the manual on the equipment being serviced for additional information. Also, refer to manuals for the additional test equipment being used.

### 7.1 TESTING A CODE PLUG

Step 1. Insert code plug into encode socket. Set ENCODE SELECT switch to left position.

Step 2. Connect CODE OUT jack to CODE IN jack.

Step 3. Set thumbwheel switches to same code as code plug being tested. Set DECODE SELECT switch to left position.

Step 4. Set both INVERTED-NORMAL switches to NORMAL.

Step 5. Set LEVEL potentiometer full clockwise.

Step 6. Set PTT switch to CONT or MOMT as desired. DECODE light should go on. If the DECODE light does not come on, the code plug is defective.

### 7.2 TESTING AN ENCODER (In a Radio)

Step 1. Connect test equipment as shown in Figure 4. Refer to manual of equipment being serviced to locate encoder code out connection point.

Step 2. Set thumbwheels on test set to same code as encoder's code plug. Set DECODE SELECT switch to left position.

Step 3. Key transmitter of radio under test. DECODE light should go on. If it doesn't, try reversing the DECODE INVERTED-NORMAL switch position. If the DECODE light still doesn't go on, the encoder under test is defective. It is either not generating code or is generating the wrong code. Use an oscilloscope to measure waveforms in the encoder under test to isolate the fault.

### 7.3 TESTING A DECODER (In a Radio)

When testing a decoder in a radio set, the "Digital Private-Line" signal is not injected directly into the decoder under test, but as shown in Figure 5. The test set CODE OUT signal is used to externally modulate an FM signal generator. The signal generator injects a code modulated carrier signal into the receiver of the radio under test. The receiver's recovered audio signal is the "Digital Private-Line" code signal, which is applied to the decoder under test. This test set-up permits easier setting of the code level to more accurately simulate actual operating conditions; it also includes the receiver in the test. Some

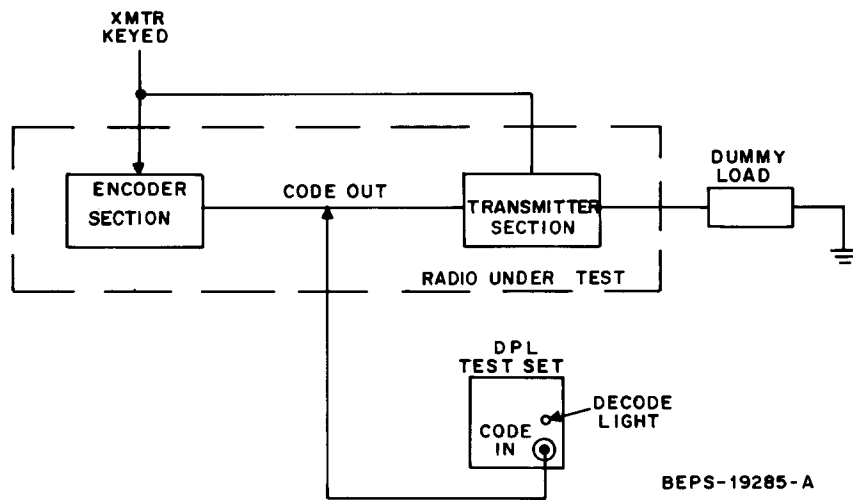

Figure 4. Encoder Test Set-Up

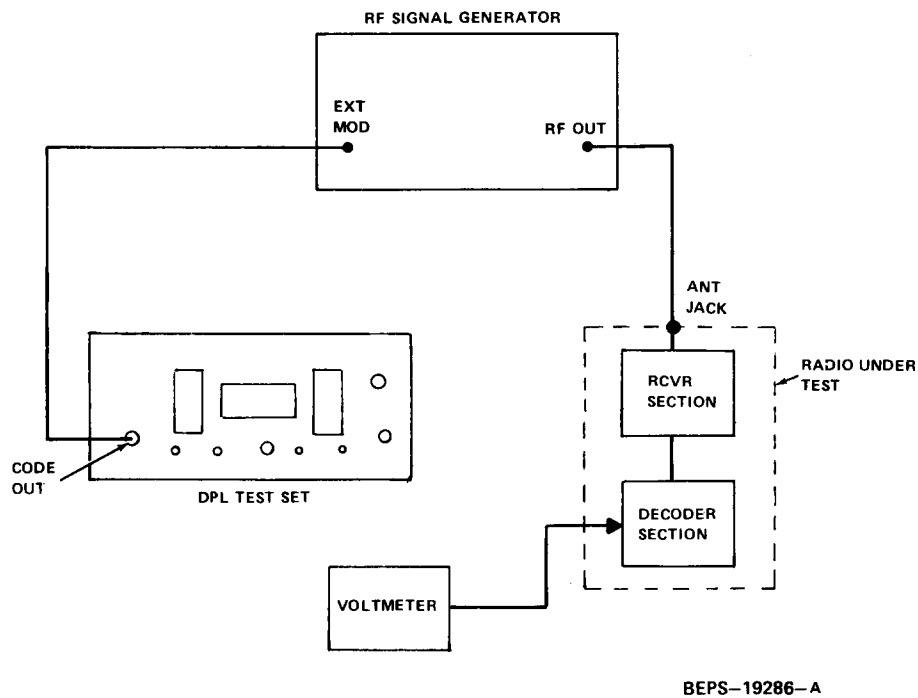

Figure 5. Decoder Test Set-Up

symptoms of improper decoding can be caused by low receiver sensitivity or other receiver problems. This set-up helps isolate such problems to the receiver or the decoder.

### NOTE

The signal generator must have an external modulation low frequency response of less than 1 Hz (essentially dc). The Motorola S1318A Series of FM Signal Generators and the S1327B Service Monitor meet this criteria. The S1327A Service Monitor needs modification to meet this requirement. Signal generators that do not meet this requirement will distort the "Digital Private-Line" code signal and destroy the accuracy of tests.

Step 1. Connect equipment as shown in Figure 5. Connect the CODE OUT jack to the external modulation jack of the rf signal generator. Connect the rf output of the signal generator to the antenna jack of the receiver under test. Set the signal generator to the exact carrier frequency of the receiver and adjust 1000 uV level. The radio PL switch should be ON (microphone on-hook on some radios).

Step 2. Set ENCODE SELECT switch to right position and set thumbwheels to same code as decoder code plug.

Step 3. Adjust LEVEL control for  $\pm 750$  Hz FM deviation of rf signal generator (see manual for test equipment being used).

Step 4. Note squelch voltage (see manual for equipment being serviced for normal squelch voltage and point of measurement). This voltage will normally be approximately the same as the dc source voltage.

Step 5. Operate PTT switch on test set. Squelch voltage should decrease to 0.1 V or less.

Step 6. If squelch voltage does not decrease to 0.1 V, try reversing code out INVERTED-NORMAL switch. If squelch voltage still does not switch decoder is defective, or signal is not getting through receiver. Use an oscilloscope to measure waveforms in the decoder under test to isolate the fault.

Step 7. Reduce signal generator output level to PL squelch threshold value for the radio under test. This value is usually stated in the receiver specification chart at the front of the

radio set instruction manual. In some radio sets, it is necessary to adjust the squelch control to minimum (fully counterclockwise). Squelch voltage (step 5) should remain at 0.1 V or less for all rf input levels above the specified threshold value. If a higher rf input level is required, receiver sensitivity may be low.

Step 8. If the radio tests normal, but will not work in the "Digital Private-Line" mode when returned to normal service, improper jumper connections in the radio may be inverting the code signal polarity. During testing, either a normal or inverted signal may be used, whichever will work. This compensates for signal inversion caused by some signal generators and permits signal injection and measurement at various circuit points. In an operating system, only one polarity of code signal will work. Code polarity depends upon the type of radio, specific frequency range, and whether the receiver uses low side or high side injection. If these factors are known, plus the normal-inverted characteristics of the signal generator being used (in some signal generators it is dependent upon the frequency band), the position of the code in INVERTED-NORMAL switch can be predetermined for a given radio and used as a check of proper polarity jumpering in the radio.

## 8. MAINTENANCE

### 8.1 CASE REMOVAL/ASSEMBLY

If it is necessary to remove the case, remove the three screws on each side rail of the front panel (side of case). Remove screw at center of each end of rear panel. Remove cover by sliding backward until the cover stops, then lift the cover vertically.

### 8.2 REMOVAL AND REPLACEMENT OF MAIN ENCODER-DECODER BOARD

#### 8.2.1 Removal

Step 1. Remove seven screws securing circuit board to chassis.

Step 2. Remove five wires that plug into circuit board pins at rear right corner.

Step 3. Remove the five plugs (J1-J5), two at the rear and three in front.

Step 4. Slide board sideways to left.

### 8.2.2 Reassembly

Reverse procedure given in paragraph 8.2.1.

### 8.3 REMOVAL AND REPLACEMENT OF RFI FILTER BOARD

Step 1. Remove main encoder-decoder board as instructed in paragraph 8.2.1.

Step 2. Remove four screws at bottom of power transformer.

Step 3. Remove four screws at both ac and dc plugs.

Step 4. Unsolder wires at fuses if necessary.

Step 5. Reverse this procedure to replace.

### 8.4 OUTPUT WAVEFORM TEST

Step 1. Connect 600-ohm resistor from CODE OUT jack to ground. Connect CODE OUT jack to oscilloscope vertical input. Connect test set ground to oscilloscope ground.

Step 2. Set controls on test set as follows:

- (1) Thumbwheels - 131
- (2) ENCODE SELECT switch - right
- (3) DECODE SELECT switch - left
- (4) INVERTED-NORMAL switches - both to NORMAL.
- (5) LEVEL control - maximum clockwise.

Step 3. Measure  $V_{\text{peak}}$ . Adjust  $V_{\text{peak}}$  for 2.0 volts.

Step 4. Measure  $T_r$  (rise time),  $T_f$  (fall time), "droop" and "raise" (see Figure 6).

Minimum output parameters are as follows:

- $T_r$  - 4 mSec
- $T_f$  - 4 mSec
- Droop - 400 mV
- Raise - 400 mV

### 8.5 CODE INPUT SENSITIVITY TEST

Step 1. Connect a 27 dB pad (minimum 600-ohm input) between CODE OUT jack and CODE IN jack. The 27 dB pad can be made by connecting a 590 ohm resistor from CODE OUT to CODE IN, and a 12-ohm resistor from CODE IN to ground. (470 and 120 ohm resistors can be used in series to make the 590-ohm resistor.) This results in 27 dB attenuation and proper impedance matching.

Step 2. Set controls on test set as follows:

- (1) Thumbwheels - 131
- (2) ENCODE SELECT switch - right
- (3) DECODE SELECT switch - left
- (4) INVERTED-NORMAL switches - both to NORMAL

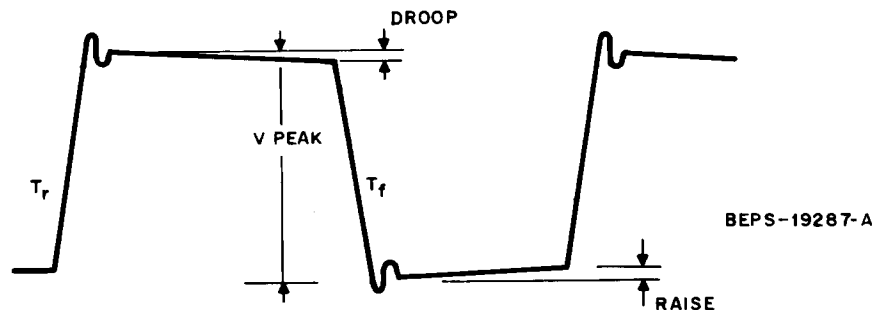

Figure 6. Output Waveform Test Oscilloscope Pattern

Step 3. Connect oscilloscope vertical input to CODE OUT jack.

Step 4. Adjust LEVEL for 2.0 V peak on oscilloscope. DECODE light should be on. When 2.0 V peak is on scope, the 27 dB attenuator reduces it to 40 mV at CODE IN plug; 1.3 V peak is 25.0 mV.

Step 5. Adjust LEVEL for 1.3 V peak. DECODE light should be on.

Step 6. Adjust LEVEL for 0.3 V peak. DECODE light should be off or blinking.

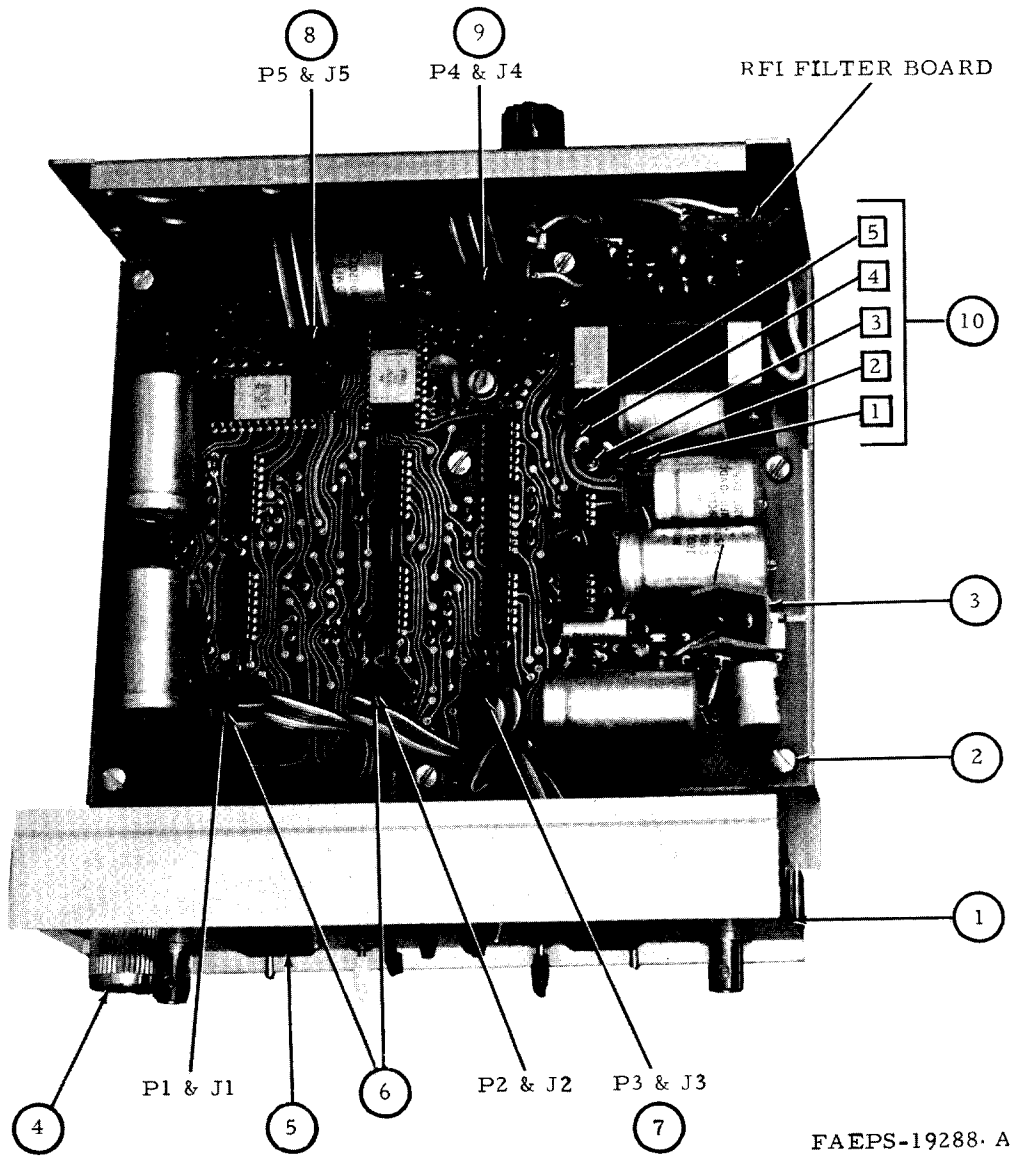

REFERENCE SYMBOL	MOTOROLA PART NO.	DESCRIPTION
------------------	-------------------	-------------

### ELECTRICAL PARTS LIST

SLN-6413A "Digital Private-Line" Test Set PL-3886-A

REFERENCE SYMBOL	MOTOROLA PART NO.	DESCRIPTION
C1, 2	23-82077C21	<u>CAPACITOR, fixed:</u> 1000 uF +150-10%; 20 V
C3 thru 10	21-82428B11	.01 uF +70-30%; 100 V
C11	8-82905G43	.022 uF ±10%; 200 V
C12	8-84326A17	.00865 uF ±2%; 50 V
C13	21-82428B11	.01 uF +70-30%; 100 V
C14	23-82077C25	500 uF +75-10%; 60 V
C15	8-864965	1.0 uF ±20%; 200 V
C16	23-82077C21	1000 uF +150-10%; 20 V
C17	23-82077C05	300 uF +150-10%; 20 V
C18	21-874352	1200 pF ±10%; 500 V
C19, 20	21-849334	20 pF ±5%; 500 V
C21	21-837747	.0047 uF ±10%; 500 V
C23	23-82077C05	300 uF +150-10%; 20 V
C24	8-82095G16	.056 uF ±20%; 200 V
C25	21-874352	1200 pF ±5%; 300 V
C26	21-82428B11	.01 uF +70-30%; 100 V
C27	8-82905G43	.022 uF ±10%; 200 V
C101 thru 105	21-801139	0.01 uF +80-20%; 600 V
CR1, 2	48-82466H13	<u>DIODE; SEE NOTE 1</u> silicon
CR3, 4	48-82466H13	silicon
CR5	48-82256C10	Zener type; 14.0 V
CR6	48-82256C15	Zener type; 5.2 V
CR101	48-82466H13	silicon
CR201	48-88245C11	LIGHT EMITTING (RED)
CR202	48-88245C12	LIGHT EMITTING (GRN)
F201	65-20987	<u>FUSE:</u> 1/4 amp; (ac)
F202	65-475395	1/2 amp; (dc)
J1, 2	9-80313A09	<u>CONNECTOR; receptacle:</u> female; 14 contact
J3, 4	9-80313A10	female; 16 contact
J5	9-80313A09	female; 14 contact
J101	28-812540	male; 2 contact (dc)
J103	9-82393K02	female; 3 contact (ac)
J203, 204	9-855268	female; single contact (BNC)
L101, 102, 103	24-80312A70	<u>COIL, RF:</u> choke; 39 uH
P1, 2	1-82822K13	<u>CONNECTOR, plug; with cable:</u> 14 pin
P3	1-82822K14	16 pin
P4	1-82822K16	16 pin
P5	1-82822K15	14 pin
Q1	48-84302A81	<u>TRANSISTOR; SEE NOTE 1</u> PNP; type 2N4919
Q2, 3	48-82554F31	NPN; type 2N4922
Q4	48-869570	NPN; type M9570
Q6	48-869652	field-effect; type M9652
Q7	48-869594	NPN; type; M9594
Q8	48-869571	PNP; type M9571
Q9 thru 12	48-869594	NPN; type M9594
R1	6-185A76	<u>RESISTOR, fixed; ±5%; 1/8 W:</u> unless otherwise stated 13k
R2, 3	6-124C09	22 ±10%, 1/4 W
R4	6-185A76	13k
R5 thru 32	6-185A97	100k
R33	6-485A49	1k
R36	6-185A49	1k
R37, 38	6-185B02	150k
R39	6-185A73	10k
R40	6-185A91	56k
R41	6-126C47	820 ±10%, 1 W
R42	6-185B02	150k
R43	6-124A73	10k, 1/4 W
R44, 45	6-185B06	220k
R46, 47	6-185B04	180k
R48	6-185A85	33k
R49, 50	6-185A91	56k
R51	6-185B14	470k
R52	6-185A77	15k
R53	6-185A73	10k
R54	6-185A89	47k

REFERENCE SYMBOL	MOTOROLA PART NO.	DESCRIPTION
------------------	-------------------	-------------

R55	6-124A47	820; 1/4 W
R56	6-126C27	120 ±10%; 1 W
R57	6-185A57	2.2k
R58, 59	6-185A73	10k
R60	6-185A91	56k
R61	6-185A73	10k
R62, 63	6-185A93	68k
R64, 65	6-185A91	56k
R66, 67	6-185A93	68k
R68, 69	6-185A65	4.7k
R70, 71	6-185A85	33k
R72 thru 78	6-185A97	100k
R101	6-124A47	820; 1/4 W
R201	18-82515B21	variable; 50k
S201	40-84309A99	<u>SWITCH:</u> dpdt
S202	40-83831A01	dpdt
S203	40-82085J01	spdt
S204	40-80310A28	momentary
S205, 206, 207	40-82085J01	spdt
S208	40-80310A93	3 position; thumbwheel
T201	25-83590D02	<u>TRANSFORMER:</u> pri: #1; res 231 ohm pri: #2; res 264 ohm sec: 34.1 ohms
U1, 2, 34	51-82764K21	type 74C157
U5, 6, 7	51-82764K01	type 74C00
U8, 9	51-84320A13	type 741
U10	51-84267A82	type M67A82
U11	51-84320A13	type 741
U12	51-84267A82	type M6782
Y5	48-82003K01	<u>CRYSTAL: Note II</u> 50 kHz

NOTE:  
I. Replacement transistors must be ordered by Motorola part number only for optimum performance.

### MECHANICAL PARTS LIST

SLN-6413A "Digital Private-Line" Test Set PL-3914-A

REF.	QTY	MOTOROLA PART NO.	DESCRIPTION
			<u>ILLUSTRATED</u>
1	1	13-83143K02	ESCUTCHEON
2	7	3-7229	SCREW, 6-32 x 3/8"
3	1	7-84234B01	HEAT SINK
4	1	36-84675F02	KNOB (LEVEL)
5	1	1-80300A22	CODE PLUG BOARD ASSY.
	2	2-10239A03	NUT, nylon 4-40
	2	2-10129A21	SCREW, nylon 4-40 x 5/8
	1	14-80312A64	INSULATOR, code plug
	1	14-83165K01	INSULATOR, guide block
6	2	42-80312A06	FASTENER dip lock, 14 pin
	2	1-82822K13	CABLE flat (P1, P2)
	2	9-80313A09	SOCKET, Integrated Circuit, 14 pin (J1, J2)
7	1	42-80313A07	FASTENER, dip lock, 16 pin
	1	1-82822K14	CABLE, flat (P3)
	1	9-80313A10	SOCKET, Integrated Circuit, 16 pin (J3)
8	1	42-80313A06	FASTENER, dip lock, 14 pin
	1	1-82822K16	CABLE, flat (P5)
	1	9-80313A09	SOCKET, Integrated Circuit, 14 pin (J5)
9	1	42-80313A07	FASTENER, dip lock 16 pin
	1	1-82822K15	CABLE, flat (P4)
	1	9-80313A10	SOCKET, Integrated Circuit, 16 pin (J4)
10	5	29-83446D01	CONTACTS, female terminal
			<u>NOT ILLUSTRATED</u>
	1	15-83144K01	COVER, test set
	4	75-83333H01	FEET
	2	9-82033501	FUSE HOLDER
	1	55-83621C01	HANDLE (on cover)
	5	4-7683	LOCKWASHER, #4
	3	4-7650	LOCKWASHER, #6
	4	2-7041	NUT, 2-56
	1	2-7019	NUT, 4-40
	22	2-82100C07	NUT, Pem; 4-40
	4	3-82100C06	NUT, Pem; 6-32
	4	3-1960	SCREW, 2-56 x 3/8"
	7	3-8022	SCREW, 4-40 x 1/4"
	6	3-1930	SCREW, 4-40 x 3/8"
	6	3-135197	SCREW; 4-40 x 1/2" flt. hd.
	2	7-83142K01	SIDE RAIL
	5	9-83445D01	TERMINAL
	13	29-15103A12	TERMINAL
	5	4-7606	WASHER #4
	2	4-135739	WASHER
	1	30-82393K01	POWER CORD
	1	14-84268A01	INSULATOR, transistor

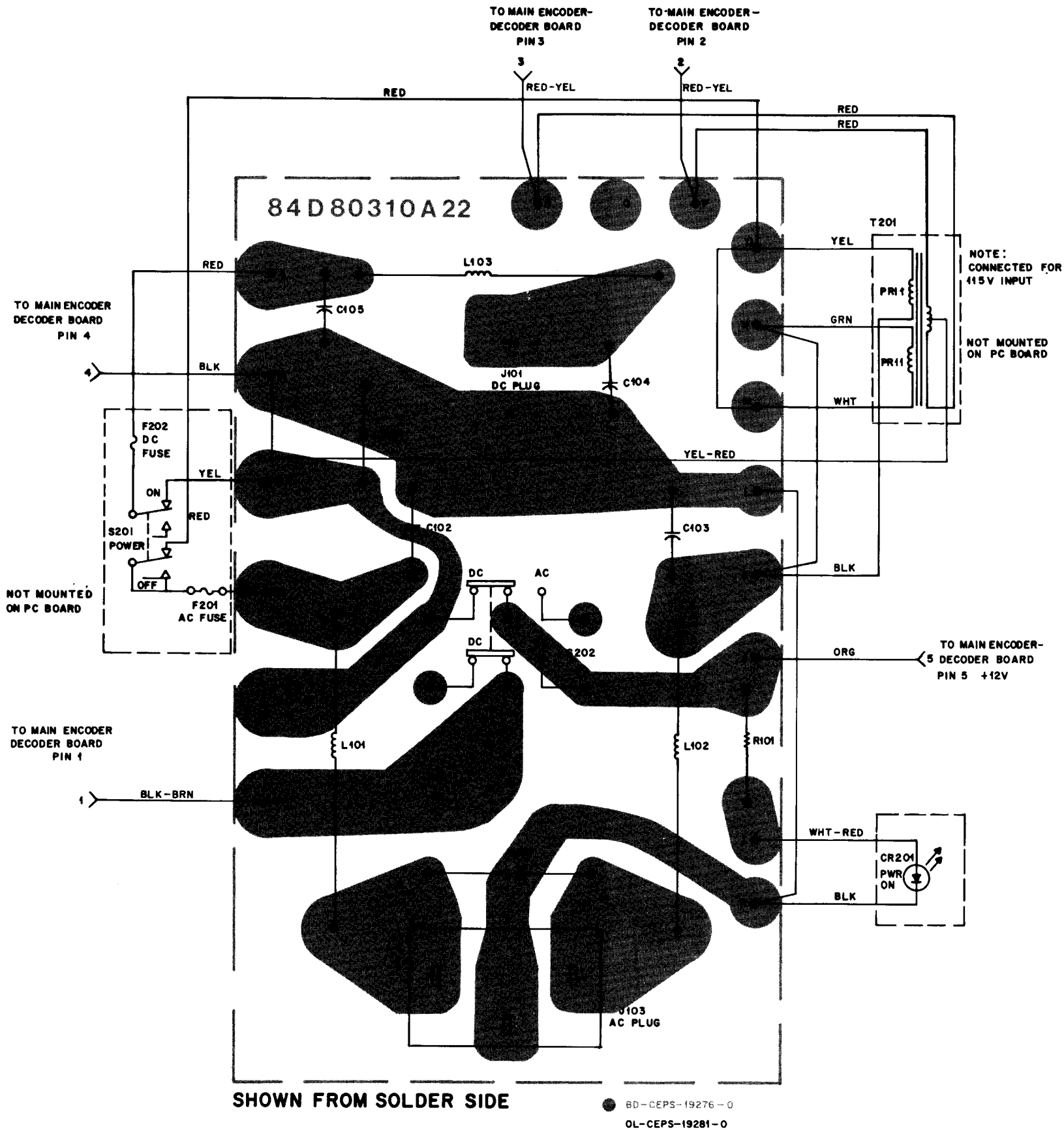

SHOWN FROM SOLDER SIDE

8D-CEPS-19276-0  
0L-CEPS-19281-0

PARTS LIST SHOWN ON  
FRONT OF THIS DIAGRAM

SLN-6413A "Digital Private-Line" Test Set  
Schematic Diagram and Circuit Board Detail  
Motorola No. PEPS-19335-A  
(Sheet 1 of 2)  
11/11/75-

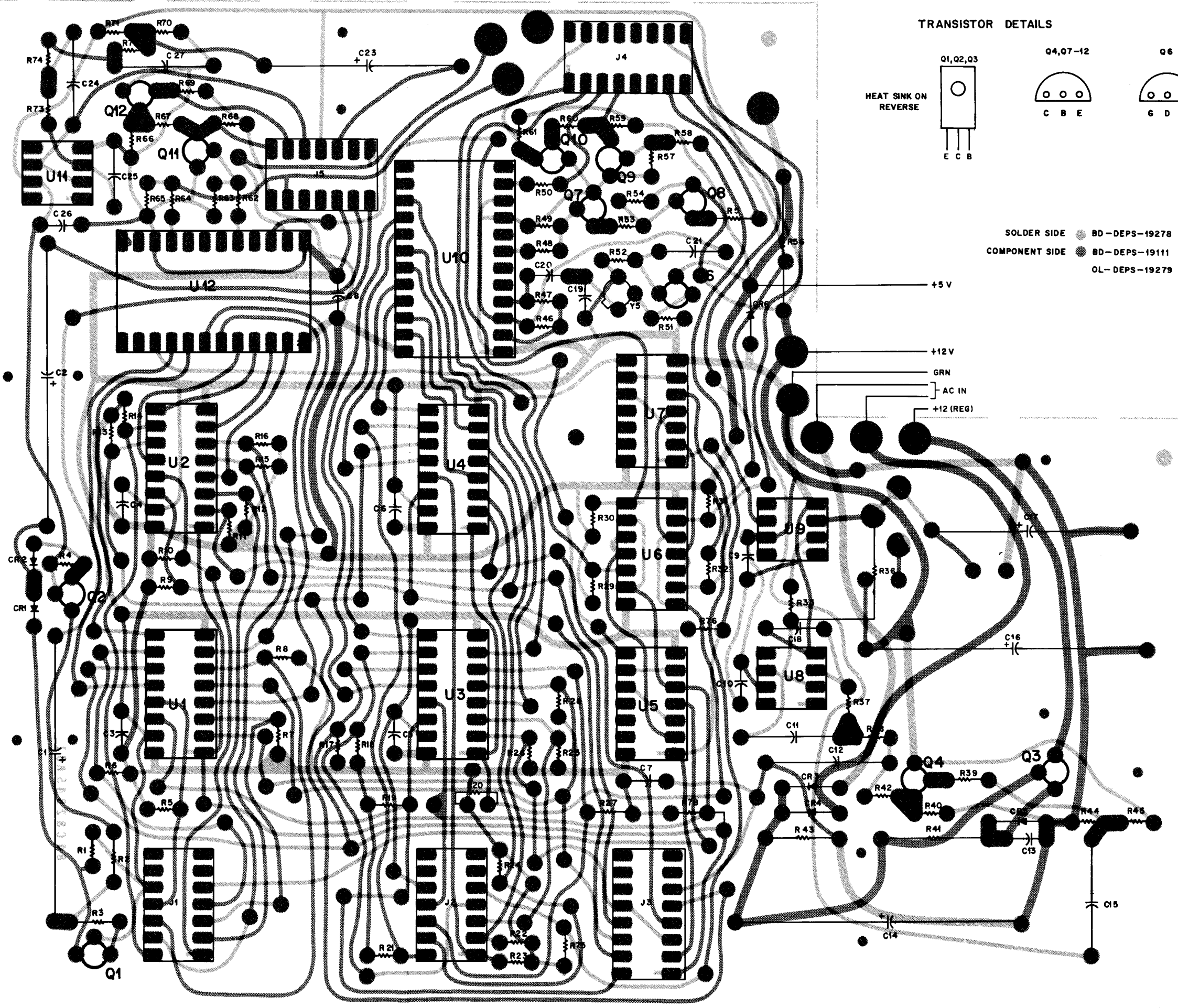

TRANSISTOR DETAILS

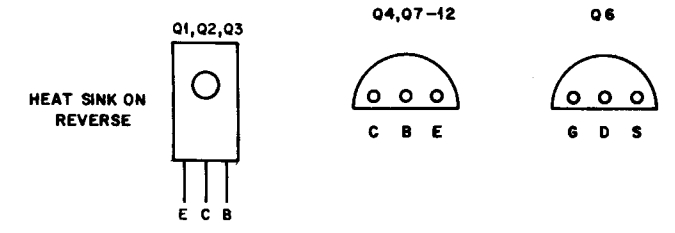

- SOLDER SIDE ● BD-DEPS-19278
- COMPONENT SIDE ● BD-DEPS-19111
- OL-DEPS-19279

SHOWN FROM COMPONENT SIDE

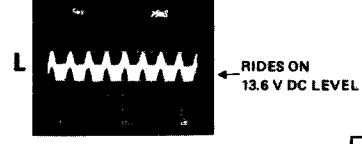
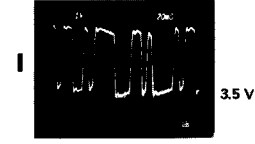
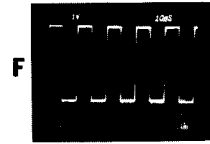
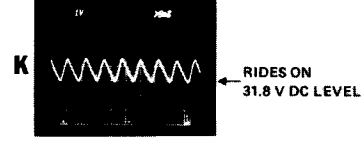
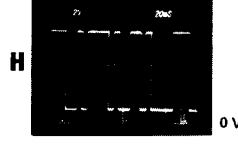
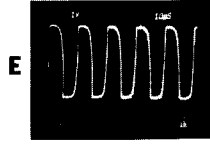
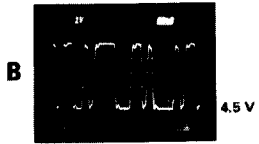
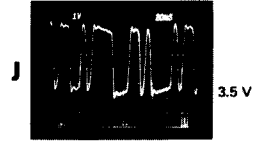
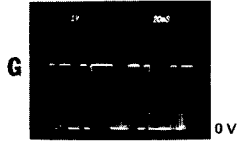
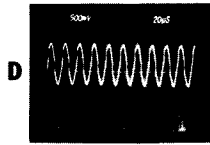
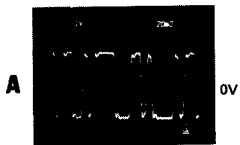

BEPS-19980-0

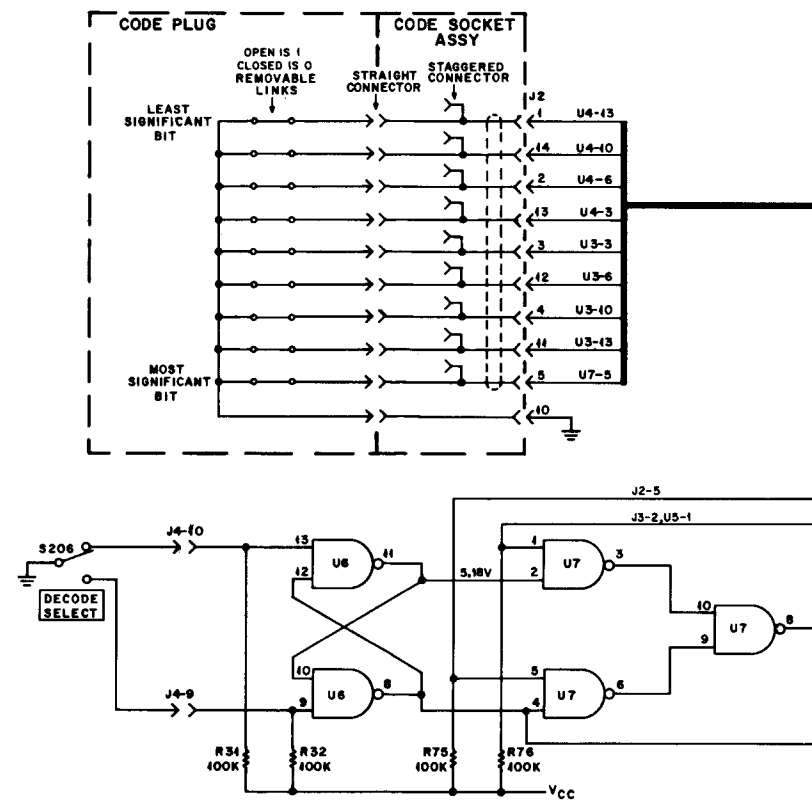
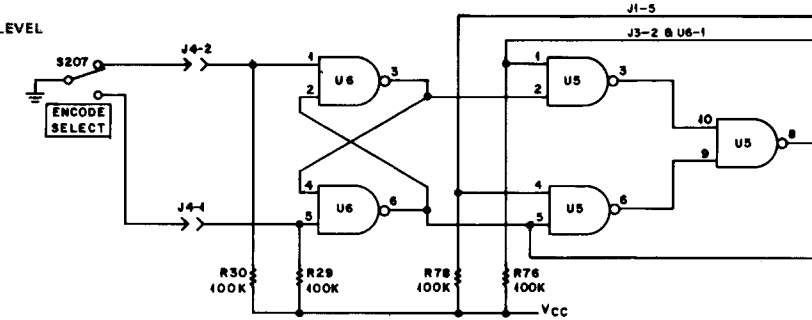
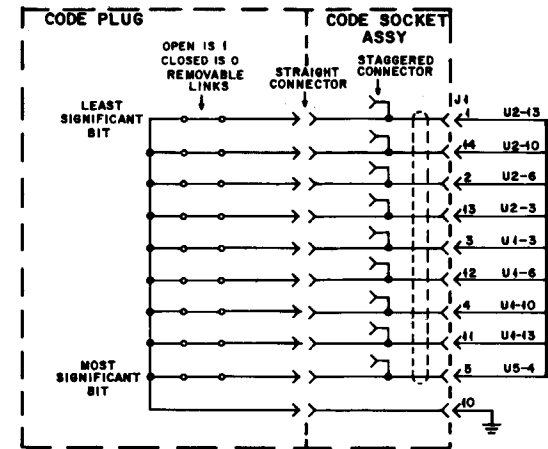
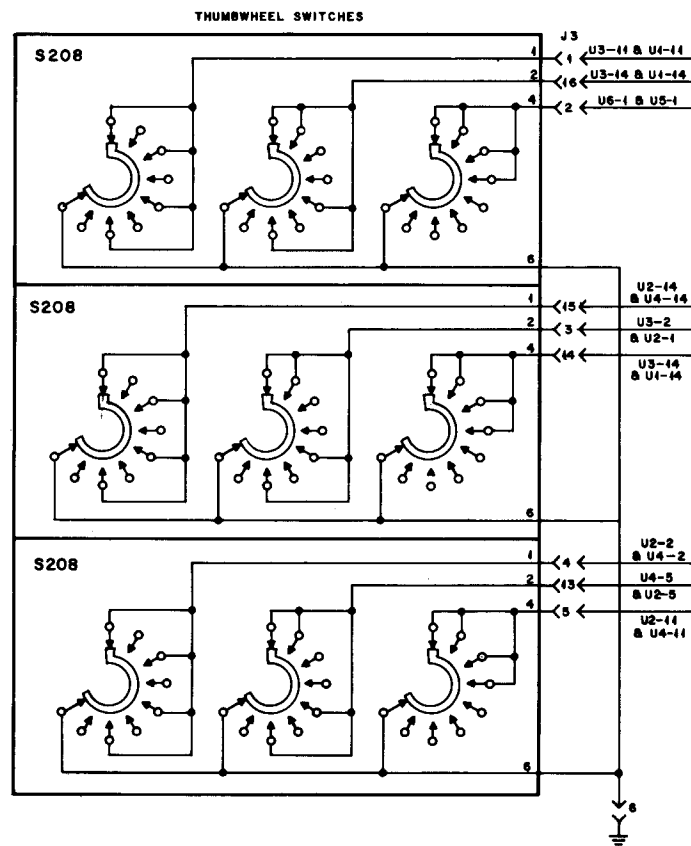

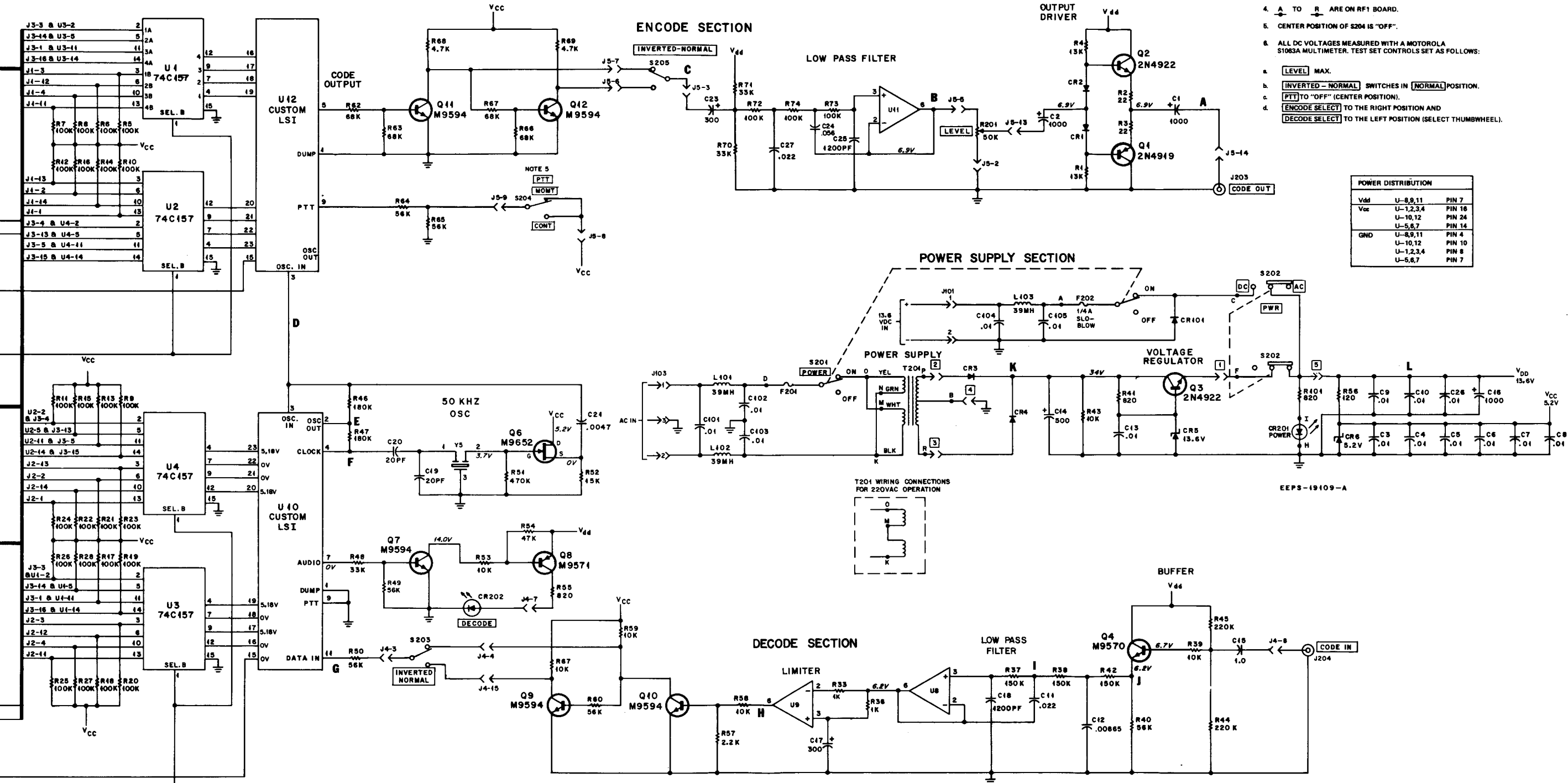

- NOTES:
- ALL CAPACITORS IN MICROFARADE UNLESS OTHERWISE SPECIFIED.
  - ALL COMPONENTS WITH 1XX DESIGNATED ON RF1 BOARD  
ALL COMPONENTS WITH 2XX DESIGNATED ON CHASSIS  
ALL COMPONENTS WITH XX DESIGNATED ON ENCODE/DECODE BOARD.
  - 1 TO 6 ARE PINS ON ENCODE-DECODE BOARD
  - A TO R ARE ON RF1 BOARD.
  - CENTER POSITION OF S204 IS "OFF".
  - ALL DC VOLTAGES MEASURED WITH A MOTOROLA S1063A MULTIMETER. TEST SET CONTROLS SET AS FOLLOWS:
    - a. LEVEL MAX.
    - b. INVERTED-NORMAL SWITCHES IN NORMAL POSITION.
    - c. PTT TO "OFF" (CENTER POSITION).
    - d. ENCODE SELECT TO THE RIGHT POSITION AND  
DECODE SELECT TO THE LEFT POSITION (SELECT THUMBWHEEL).

SLN-6413A "Digital Private-Line" Test Set  
Schematic Diagram and Circuit Board Detail  
(Motorola No. PEPS-19335-A  
Sheet 2 of 2)  
11/11/75-