

MOTOROLA

MICROPHONE TESTER

MODEL ST855



AEPS-4662-O

1. DESCRIPTION

The ST855 Microphone Tester is a compact battery-operated test unit capable of checking all commonly used Motorola microphones with the exception of the "speaker type". The unit provides a complete audio power amplifier, tone oscillator and AC Voltmeter. Any microphone can be tested simply by plugging it into the unit. Keying the microphone turns on an internal 1 kHz oscillator which then can be fed into the microphone cartridge for checking output. The built-in voltmeter measures the output of the microphone cartridge. The selector switch allows for using the amplifier and speaker to monitor the audio coming through the microphone. This tester will check microphone

cartridge operation, internal circuitry, keying and switching, cord, and plug. It can also be used as a measured acoustical tone source for transmitter IDC adjustments.

The ST855 Microphone Tester is designed to expedite servicing and maintenance of microphones by providing a rapid, practical, operational field test. This unit does not provide a precise measurement of the acoustical parameters of the microphone being tested. After the technician acquires experience with the tester, he will be able to use the level control and interpret the vu meter readings correctly and therefore classify microphones into group-types. A record should be kept of these tests and a Reference Data Sheet is provided for this purpose.

Power for the tester is supplied by two, self-contained, mercury batteries. A tip jack is provided on the front panel to monitor the battery voltage. A negative 10.75 volts or greater should appear at the test point (BAT TEST) when a microphone is properly connected to the tester and the microphone P-T-T switch is depressed. If the voltage does not read -10.75 volts or greater the batteries should be replaced. (See Note in Parts List)

The circuitry is comprised of discrete components which provide high reliability and ease of servicing. The microphone tester circuitry has four basic sections. (Refer to the block diagram.)

-- A 1 kHz phase-shift oscillator that provides a tone source.

-- An audio amplifier to drive the speaker (voice box). This amplifier has a high input impedance to prevent loading of certain high impedance microphones.



MOTOROLA INC.

ENGINEERING PUBLICATIONS

1301 E. ALGONQUIN ROAD

Communications Division

SCHAUMBURG, ILLINOIS 60172

Copyright 1970 by Motorola, Inc.
Printed in U. S. A.
11/25/70-NPC

-- A high impedance AC Voltmeter which provides an 8 mV sensitivity for "0" output as indicated by the meter.

-- A three-position function switch (S1) that provides TONE LEVEL, MIC TEST, and VOICE TEST functions. A mic selector switch provides the necessary attenuators and dc biasing to accommodate a variety of microphones.

2. OPERATION

- a. Set the microphone selector switch to the type of microphone to be tested.
- b. Set the function switch to the LEVEL position.
- c. Connect the microphone to the appropriate receptacle. Microphones with individual leads may be checked by using a Motorola Model ST868 Adapter.
- d. Depress the microphone P-T-T switch and adjust the level control until the vu meter reads 0. Microphones that have a very high output (such as carbon types) should be matched to the tester by adjusting the LEVEL control until -20 (20 below reference 0) is indicated by the vu meter.
- e. Set the function switch in the MIC TEST position.
- f. Place the microphone over the padded speaker opening (voice box) (refer to Figure 1) on the tester

front panel in such a way as to provide good acoustical coupling (microphone placed against the pad firmly, but without excessive pressure).

NOTE

When testing microphones (miniature type) with small acoustical openings, it will be necessary to use the voice box adapter disc shown in Figure 1. The adapter disc is placed inside the "voice box" pad flush against the speaker grill. The smaller microphone is then acoustically coupled to the voice box by being placed firmly against the reduced sized opening.

- g. Depress the microphone P-T-T switch, the vu meter should read 0 ± 3 for a good microphone.
- h. Turn the LEVEL control fully counterclockwise and place the function switch in the VOICE TEST position.
- i. Depress the microphone P-T-T switch and speak into the microphone, saying the word "four". Advance the LEVEL control until the audio level can be clearly heard. An indication of the microphone output can now be read on the meter.

NOTE

Acoustical feedback will occur if the LEVEL control is advanced too far.

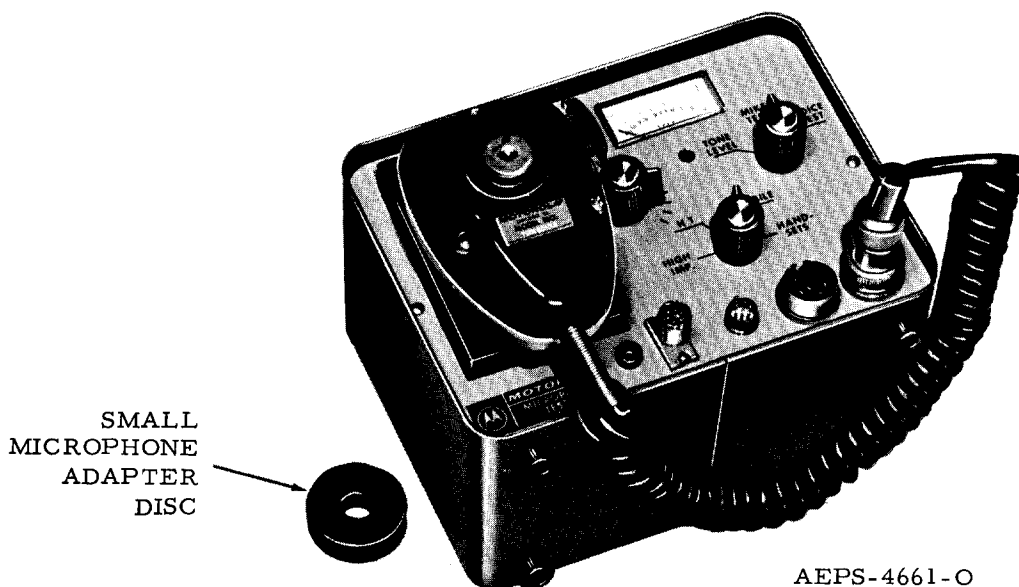

Figure 1.
Acoustical Coupling

3. CALIBRATION

- a. Using a voltmeter (Simpson 260 or equivalent) connected to the BATT TEST jack, determine if the battery voltage is at least 12 V when a microphone connected to the correct mic receptacle is keyed.
- b. Place the function switch in the MIC TEST position and the microphone selector switch in the HIGH IMP position.
- c. Key the tester by shorting pin 3 of the four pin microphone receptacle to the shell (case ground).
- d. Using a high impedance AC Voltmeter (Motorola Model S1051C or equivalent) adjust the LEVEL control for 275 mV rms across the speaker (voice box) voice coil.
- e. Connect the AC Voltmeter between the base of Q7 and ground and adjust resistor (R20) Amplifier Output Calibrate (refer to Figure 2, the parts location detail) for an 8 mV rms reading.
- f. With the 8 mV audio tone on the base of Q7 adjust (R24) Meter Calibrate for a "0" reading on the vu meter.

NOTE

The ST855 Tester is now standardized. All other microphones are measured

relatively by switching in various attenuators (with the microphone selector switch) to provide correct correlation.

- g. Follow steps 2 a, 2 b, 2 c, and 2 d of the OPERATION section of these instructions using a microphone known to be good.
- h. Couple the microphone to the tester as directed in steps 2 e and 2 f.
- i. Depress the P-T-T switch on the microphone and adjust the associated microphone calibration potentiometer for a "0" reading on the vu meter.

NOTE

To calibrate microphones with high output levels (such as carbon units) it is necessary to reduce the tone level until it reads "20" (to the left of "0") to remain within the meter range when the function switch is switched to the MIC TEST position. Use the front panel LEVEL control to reduce this level for this type of microphone.

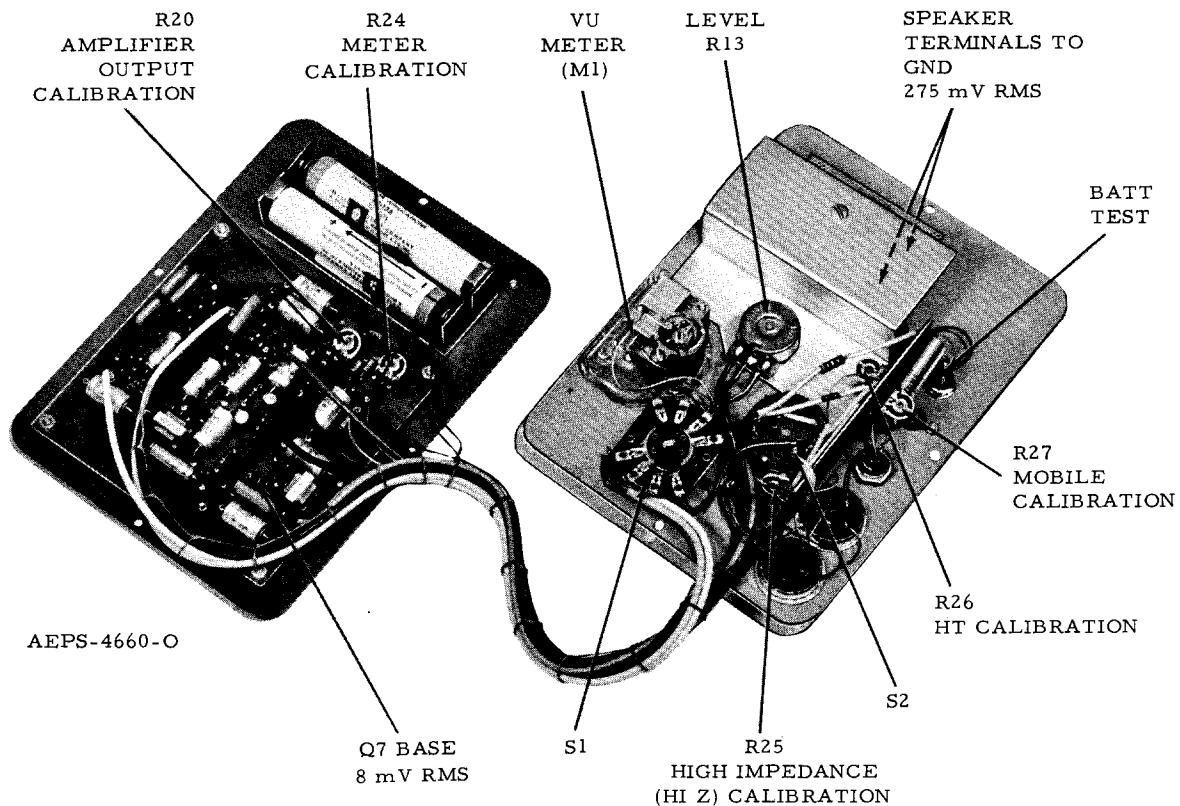
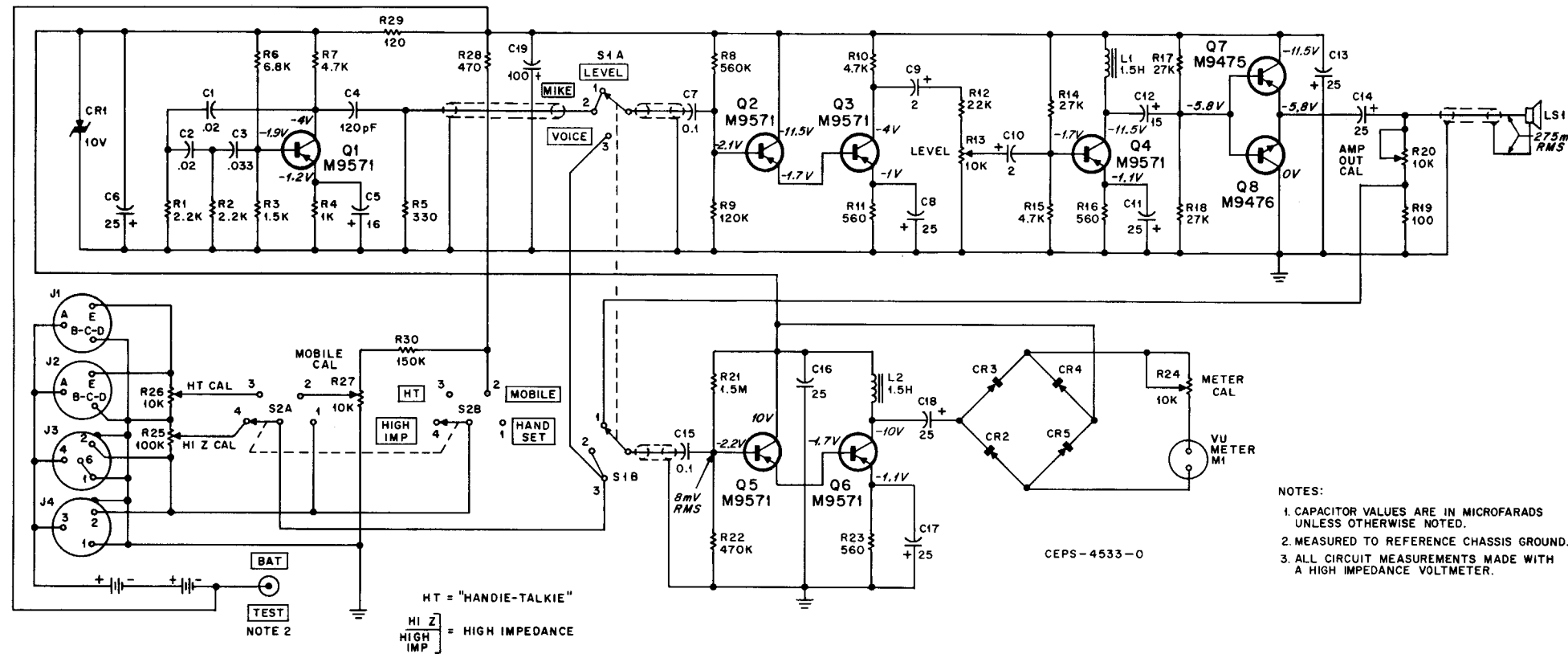
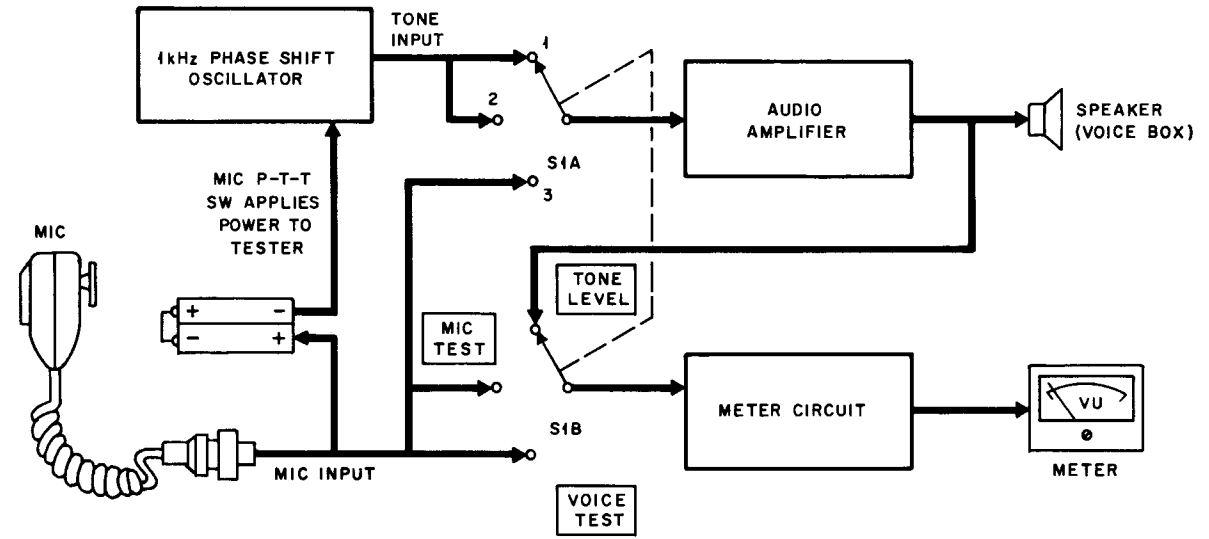

Figure 2.
ST855 Component Location Detail



- NOTES:
1. CAPACITOR VALUES ARE IN MICROFARADS UNLESS OTHERWISE NOTED.
 2. MEASURED TO REFERENCE CHASSIS GROUND.
 3. ALL CIRCUIT MEASUREMENTS MADE WITH A HIGH IMPEDANCE VOLTMETER.

See battery note in parts list.



S4 POSITION	TEST PERFORMED
1 TONE LEVEL	ALLOWS VU METER TO BE SET AT ZERO
2 MIC TEST	USES TONE OUTPUT TO DETERMINE MIC CONDITION
3 VOICE TEST	ALLOWS MIC AUDIO TO BE HEARD WHILE VU METER SHOWS MIC OUTPUT

BEPS-4663-0

PARTS LIST SHOWN ON BACK OF THIS DIAGRAM

Model ST855
 Microphone Tester
 Schematic Diagram
 Motorola No. PEPS-4739-O
 11/25/70-NPC

REFERENCE SYMBOL	MOTOROLA PART NO.	DESCRIPTION
------------------	-------------------	-------------

REFERENCE SYMBOL	MOTOROLA PART NO.	DESCRIPTION
------------------	-------------------	-------------

PARTS LIST

ST855 Microphone Tester

PL-1157-O

NON-REFERENCED ITEM		
	75P84306A63	ADAPTER, "voice box"

NOTE:

Replacement diodes and transistors must be ordered by Motorola part number only for optimum performance.

Note: This device uses two mercury batteries of the following brands and types:

Eveready E135
Mallory TR-135
Ray-O-Vac T-135

This is a 1000 mAh battery rated at 7.0 volts, and is 0.662" diameter and 3.245" long.

		<u>CAPACITOR, fixed: uF: +150</u> -10%; 20 V; unl. stated
C1	8D82905G23	.02 ±10%; 100 V
C2	8D82905G23	.02 ±10%; 100 V
C3	8D82905G16	.033 ±10%; 100 V
C4	21K840713	120 pF ±.5 pF; 500 V
C5	23D82601A10	16 +33-10%; 10 V
C6	23D82601A26	25
C7	8D82905G22	0.1 ±10%; 100 V
C8	23D82601A26	25
C9	23D82601A34	2; 25 V
C10	23D82601A34	2; 25 V
C11	23D82601A26	25
C12	23D82601A31	15; 25 V
C13	23D82601A26	25
C14	23D82601A26	25
C15	8D82905G22	0.1 ±10%; 100 V
C16	23D82601A26	25
C17	23D82601A26	25
C18	23D82601A26	25
C19	23D82601A09	100; 25 V
		<u>SEMICONDUCTOR DEVICE,</u> <u>diode: (SEE NOTE)</u>
CR1	48D82256C11	silicon
CR2 thru 5	48C847274	germanium
		<u>COIL, RF:</u>
L1	25B82751D01	choke; 1.5 H
L2	25B82751D01	choke; 1.5 H
		<u>LOUSPEAKER, permanent</u> <u>magnet:</u>
LS1	50D82660D01	round, 2-1/4" x 2-1/4"; 50 ohms impedance
		<u>METER, audio level:</u>
M1	72C83270G01	-20 to +3 vu
		<u>TRANSISTOR: (SEE NOTE)</u>
Q1 thru 6	48R869571	P-N-P; type M9571
Q7	48R869475	P-N-P; type M9475
Q8	48R869476	N-P-N; type M9476
		<u>RESISTOR, fixed: ±10%; 1/4 W:</u> unl. stated
R1	6S128689	2.2k
R2	6S128689	2.2k
R3	6S127803	1.5k
R4	6S127802	1k
R5	6S129775	330
R6	6S128687	6.8k
R7	6S127804	4.7k
R8	6S129247	560k
R9	6S128987	120k
R10	6S127804	4.7k
R11	6S129620	560
R12	6S128685	22k
R13	18D82515B03	var: 10k; 0.25 W
R14	6S127806	27k
R15	6S127804	4.7k
R16	6S129620	560
R17	6S127806	27k
R18	6S127806	27k
R19	6S129753	100
R20	18K864068	var: 10k ±20%; 1/8 W
R21	6S129014	1.5 meg.
R22	6S129148	470k
R23	6S129620	560
R24	18K864068	var: 10k ±20%; 1/8 W
R25	18K861480	var: 100k ±20%; 1/8 W
R26	18K864068	var: 10k ±20%; 1/8 W
R27	18K864068	var: 10k ±20%; 1/8 W
R28	6S6090	470; 1/2 W
R29	6S5551	120; 1/2 W
R30	6S129146	150k
		<u>SWITCH, rotary:</u>
S1	40B890196	2 pole; 3 position
S2	40A82739G01	2 pole; 4 position

TEST REFERENCE DATA

MICROPHONE TYPE	LEVEL SET	TEST READING ±3	MIC SELECTOR
(EXAMPLE) Carbon Mic Handset	-20	0	Mobile
(EXAMPLE) TMN6013A	0	0	Mobile
(EXAMPLE) NLN6024B	0	0	HT (use adapter)

END OF DOCUMENT