

FUNCTIONAL DESCRIPTION

APPLICATIONS68P81062E59
REMOTE CONTROL68P81062E61

RF-CONTROL CHASSIS

RF-CONTROL CHASSIS (TLN2472B, 74B, 75B) (B VERSION)68P81070E88
---	--------------

REMOTE CONTROL

REMOTE CONTROL MODULES68P81062E63
STATION CONTROL (TRN5321A)68P81062E14
LINE DRIVER (TRN5235A, 36A, 37A)68P81062E13
LINE DRIVER (TRN5240A, 54A, 55A, 56A)68P81062E16
DC TRANSFER (TRN5239A, 57A)68P81062E17
GUARD TONE DECODER (TLN2443A, 50A)68P81062E18
F1 TONE CONTROL (TRN5320A, 22A, 27A, 28A)68P81062E19
F2 TONE CONTROL (TLN2444A, 49A, TRN5256A, 5325A)68P81062E21
SQUELCH GATE (TRN5324A)68P81062E23
TIME-OUT TIMER (TRN2442A)68P81062E24
SINGLE-TONE DECODER (TLN2442A)68P81062E26
4-FREQUENCY CONTROL OPTION DECODER (TRN5296A)68P81062E22
SQUELCH, REPEATER, AND <i>PRIVATE-LINE</i> CONTROL OPTION DECODER (TRN1249A, 50A, 51A)68P81062E28
"WILD CARD" CONTROL (TLN2448A)68P81062E27

AUDIO & SQUELCH

R1 AUDIO & SQUELCH MODULE (TRN9688A, 89)68P81070E57
R1 AUDIO & SQUELCH MODULE (TRN5068A, 69A)68P81062E57
R2 AUDIO & SQUELCH MODULE (TRN9690A, 91A, 92A)68P81070E58
R2 AUDIO & SQUELCH MODULE (TRN5070A, 71A, 72A)68P81062E64
TONE <i>PRIVATE-LINE</i> ENCODER-DECODER MODULE TRN5073A, 74A, 75A)68P81062E51
DIGITAL <i>PRIVATE-LINE</i> ENCODER-DECODER MODULE (TRN5076A, 77A, 78A)68P81062E52

OPTIONAL EQUIPMENT

<i>Spectra-TAC</i> ENCODER OPTION (C269)68P81112E78
<i>Spectra-TAC</i> 4-WIRE LINE DRIVER MODULE (TRN5294A)68P81062E41
<i>Spectra-TAC</i> ENCODER MODULE (TRN5293A)68P81062E42
<i>Spectra-TAC</i> SQUELCH GATE MODULE (TRN5331A)68P81062E43
MSR 2000 BASE AND REPEATER STATION MULTIPLE TONE PL OPTIONS (C158, C261, C262, C263)68P81112E80
MULTIPLE PL MATRIX CONTROL MODULE (TRN5330A)68P81062E67
MULTIPLE PL ENCODER MODULE (TRN5292A)68P81062E68
MULTIPLE PL ENCODER MODULE (TRN5329A)68P81062E69



1. INTRODUCTION

Motorola base and repeater station applications are described in the following paragraphs. The information is tailored to *MSR 2000* type stations.

2. APPLICATIONS

2.1 BASE STATIONS

Typically, a base station is the core of a two-way communications system. It is the fixed point from which a dispatcher sends and receives messages from the mobile and portable radios of the communications system. In many systems, the station also transmits and receives from other base stations or repeaters at fixed points within communications range.

Remotely controlled Motorola base stations may be located at the most advantageous point for rf propagation, such as the top of a tall building or a mountain peak, while the dispatcher may be located elsewhere, even several miles away. A wire line pair (such as a leased telephone line) connects between the base station and a remote control console at the dispatcher's location. Received audio from the base station is sent over the wire line to a speaker in the remote control console. Likewise, microphone audio from the remote control console is sent over the wire line to the base station to modulate the transmitter's rf carrier signal. In addition, the remote control console generates the commands necessary to operate the base station, such as transmitter keying, frequency selection (on two- or four-frequency base stations), *Private-Line* disabling of *Private-Line* receivers to allow monitoring of all on-channel communications, and receiver muting of receiver No. 2 in two-receiver stations. Circuits in the base station sense the commands generated by the remote control console and perform the necessary switching to change the mode of operation.

Two basic types of remote control commands are used for base station control; dc control and tone control. DC control uses dc current of varying magnitude

and polarity to initiate the various control functions such as transmitter keying. The wire line pair must have dc continuity to be used for dc remote control operation. In some areas, telephone line pairs with dc continuity are not available. The wire line pair need not have dc continuity for tone remote control operation. Tone control uses audio tones of various frequencies to initiate the control functions. The audio tone used for transmitter keying is filtered out of the transmit audio so that the tone is not transmitted. Other commands require only a momentary application of the tone command to initiate the desired mode of operation. Additionally, more functions can be remotely controlled with tones since many different audio frequencies can be used.

A wide variety of station models are available. Models are available with various power output levels, with one-, two-, or four-frequency transmitters; one-, two-, or four-frequency receivers; with two separate receivers (for continuous monitoring of two channels); and with dc or tone remote control operation. In addition to the standard models offered, a wide variety of optional accessories are available to tailor the station to meet your communications system needs. Furthermore, the equipment was built to meet a wide flexibility of operational requirements without major equipment modification. For example, a station with two receivers can be (1) jumpered to provide receiver No. 1 priority, wherein receiver No. 2 is automatically muted whenever receiver No. 1 is receiving a signal; or (2) with a 4-wire audio line driver, receiver No. 2 audio can be carried to the dispatcher's location (or a completely separate location) on a separate wire line pair and no muting of receiver audio would occur; or (3) with an F2-R2 Mute module, the dispatcher could mute receiver No. 2 upon command from the console; or (4) with an F2-R2 Mute module, receiver No. 2 audio could be attenuated (via the line driver module) rather than fully muted upon command from the console. Jumper selection allows a preset attenuation of 10, 20 or 30 dB.

In all cases, the remote control console must be compatible with the base station. That is, it must generate the type of commands to which the base station control circuits will respond.

The *MSR 2000* rf-control chassis can accept plug-in modules for dc or tone control and a station may be equipped to operate with *both* types of control. This feature allows a station to be easily converted from one type of control to the other, if necessary.

2.2 REPEATER (RT) STATIONS

Motorola repeater (RT) stations are for use in two-way FM radio communications systems where extended range operation is required or where natural or man-made limitations to direct communications are encountered. The station is normally operated unattended and is used primarily for "mobile relay" or "one-way talk-back" repeater applications. Refer to Figure 1 for typical examples of these repeater systems.

Repeater (RT) stations have the capability of functioning both with an rf input (RT) and with wire line control (base station). When the remote supervisory facilities are not used, the station functions automatically as a repeater (RT); i.e., all control functions for the station are initiated via the received rf carrier. As a signal is received, the transmitter is automatically actuated, via the squelch gate module. The output of the receiver is fed to the transmitter modulator input circuit so that the received signal is rebroadcast at greatly increased power on the repeater transmitter frequency.

A station using supervisory remote wire line control can operate as an unattended repeater (RT) station or as a remotely controlled base station. The operator has priority over the operation of the station. The station operates as a repeater (RT) until the remote control operator initiates a transmission. In which case, the station operates as a conventional base station. The remote control operator may monitor all messages rebroadcast from the station during repeater (RT) operation.

A time-out timer module is supplied with all repeater (RT) stations. The time-out timer turns off the transmitter after a predetermined "on-the-air" time to prevent inadvertent continuous transmitter key-up. Jumper connections on the module provide a variable time period during which the transmitter may be keyed.

2.2.1 "Mobile Relay" System

In a "mobile relay" repeater system, signals received by the repeater from one mobile unit are rebroadcast to other mobiles in the system. Mobiles in this system must use a transmitter and receiver operating on different frequencies. The repeater transmitter and receiver will consequently operate on exactly the reverse frequencies of those used for the mobile transmitter and receiver.

2.2.2 "One-Way Talk Back" System

In a "one-way talk-back" repeater system, signals sent from a mobile unit in the vicinity of the

repeater installations are picked up by the repeater and retransmitted to a distant base station in the system. Return signals transmitted by the base station are received directly by the mobile. The mobile transmitter and receiver normally operate on the same frequency in this type of system. The associated repeater receiver operates on the mobile transmitter frequency, while the repeater transmitter operates on the frequency of the remote base station receiver. If the base station involved is equipped with a second receiver which operates on the frequency of the mobile transmitter, a mobile unit may talk directly to the base station when operating in the immediate base station area (see dotted detail on system diagram).

2.3 REPEATER (RA) STATIONS

2.3.1 "Two-Way Radio Relay" System

A Motorola repeater (RA) station features specific control facilities and circuitry to operate a companion base (RA) station in a "two-way radio relay" repeater system. Refer to Figure 2 for a typical example of this system.

Motorola radio controlled relay stations are used in two-way FM radio communications systems where extended range operation is required, or where natural or man-made limitations to direct communications are encountered. The radio repeater (RA) system consists of a repeater (RA) — base (RA) combination and two or more remote stations such as control and mobile stations. The repeater (RA) — base (RA) combination consists of a repeater (RA) station and a base (RA) station connected by audio and control wire lines.

A standard Motorola base station of selected operating frequencies can be used as the control station for the repeater (RA) — base (RA) combination. To control the repeater (RA) — base (RA) combination from a single control terminal, the repeater (RA) — base (RA) combination antennas should be directional. However, to control the repeater (RA) — base (RA) combination from several terminals at different locations in the system, multi-directional antennas should be used.

By proper location of the repeater (RA) station, and by proper selection of operating frequencies, transmitter rf power output and antenna characteristics, radio signals can be relayed through mountainous or other obstructive terrain, or to an operational area located at an extended range from the control station.

The repeater (RA) — base (RA) combination has two modes of operation. It can: (1) receive and retransmit a message from a control station to a mobile station and (2) receive and re-transmit a message from a mobile station to a control station.

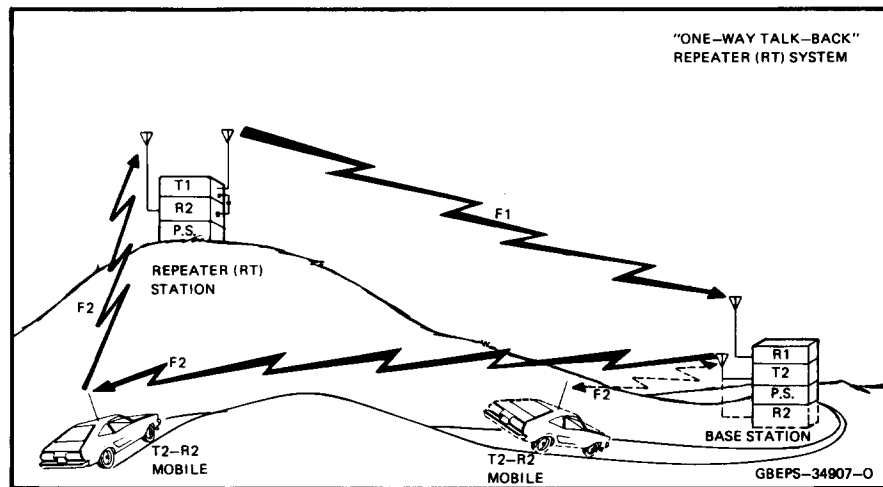
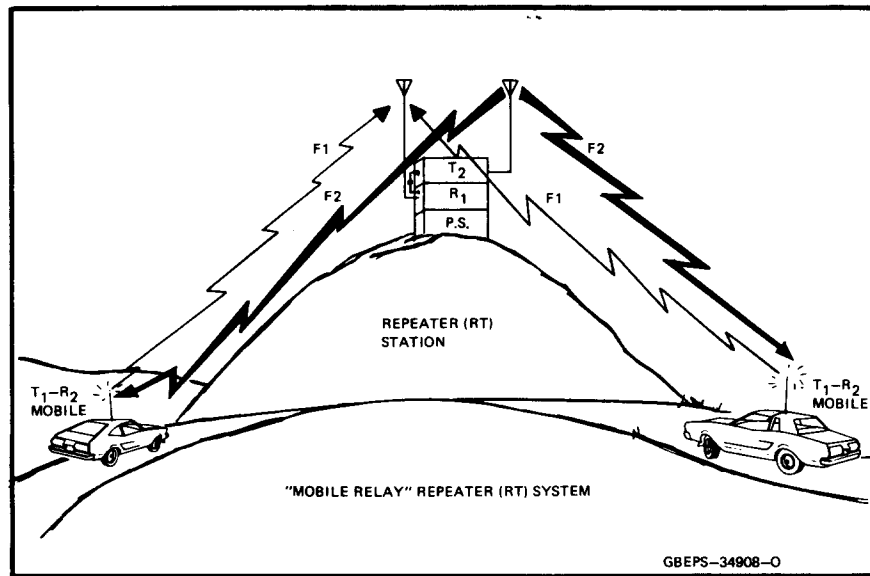

Figure 1.
Typical Repeater (RT) Systems

The mobile units and the base (RA) station operate on frequency F_1 . The repeater (RA) station transmits on frequency T_2 and receives on frequency R_1 . The control station transmits on frequency T_1 and receives on frequency R_2 .

When the control station calls the mobile unit, the repeater (RA) turns on the base (RA) station transmitter. When receiver quieting of the repeater (RA) station reaches predetermined level, the squelch gate in the repeater (RA) station actuates. This keys the transmitter in the base (RA) station. Audio is routed from the repeater (RA) station receiver to the base (RA) station transmitter audio input. The message is sent to the mobile units on frequency T_1 by the base (RA) station transmitter.

When a mobile station calls the control station, the base (RA) station turns on the repeater (RA)

transmitter. When receiver quieting of the base (RA) station reaches a predetermined level, the squelch gate in the base (RA) station actuates. This keys the transmitter in the repeater (RA) station. Audio is routed from the base (RA) station receiver to the repeater (RA) station transmitter audio input. The message is sent to the control station on frequency T_2 by the repeater (RA) transmitter.

2.3.2 "Guard Tone Relay" System

A "guard tone relay" repeater system is much like the usual "two-way radio relay" repeater (RA) system — with greatly expanded control capability.

In the typical "RA" system (refer to Figure 2) a received message at the repeater (RA) station actuates the squelch gate in that station. This keys the companion base (RA) station which retransmits the message to

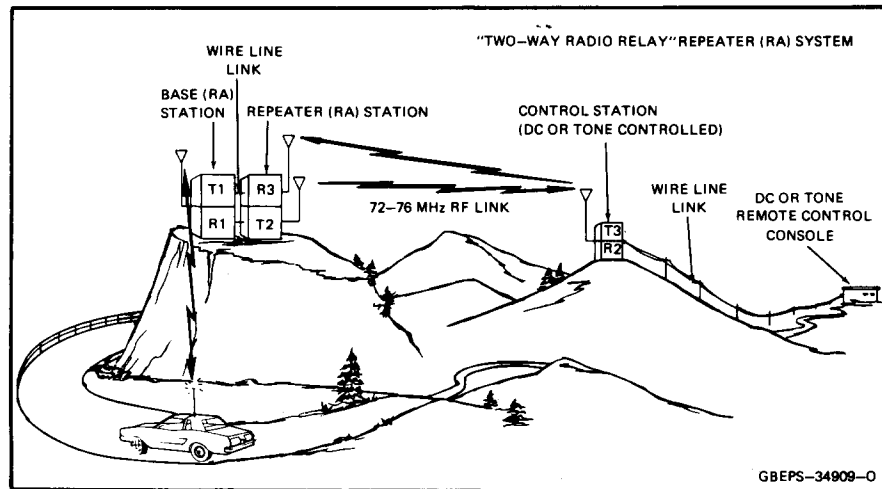

Figure 2.
Typical Two-Way Radio Relay System

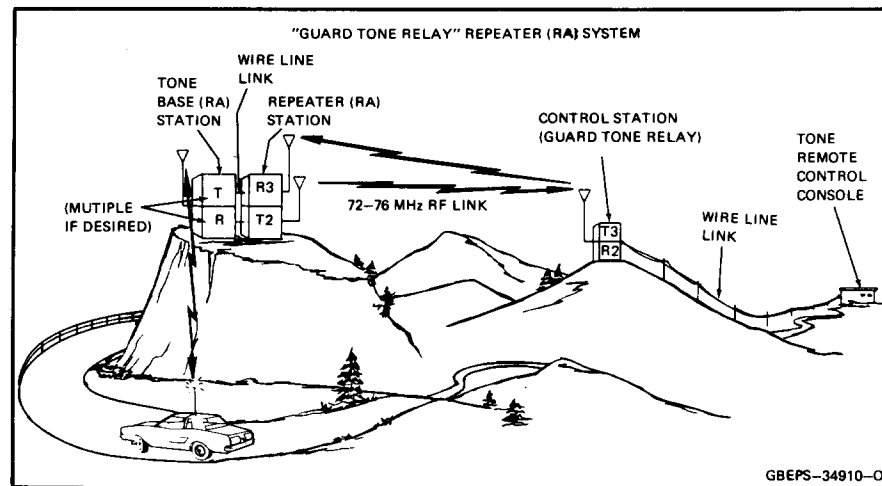

Figure 3.
Typical Guard Tone Relay System

mobile units. Only transmitter turn-on and turn-off control of the base (RA) station is possible in this system, as determined by receiver quieting-squelch gate module operation in the repeater (RA) station.

In the "guard tone relay" repeater (RA) system (refer to Figure 3) the presence of an rf signal alone at the repeater (RA) station does NOT cause the companion station to transmit. Instead, the companion station is controlled via tone signals, just as if it were connected directly to a remote control console by a wire line pair. This permits multiple frequency operation (of the companion base station), PL disable (with coded squelch models), unique function commands, etc.

For example, should the remote control console operator want to talk to a mobile unit on frequency T₄, a high level guard tone signal is sent to the control station. The control station keys IMMEDIATELY on frequency T₃ and transmits the remaining guard tone signal to the repeater (RA) station. The repeater (RA) station

applies the received high level guard tone signal portion to the audio input of the companion tone controlled base (RA) station, which is then ready to accept and react to the forthcoming T₄ function tone. The flexibility and number of functions in the guard tone relay system is limited only by the sophistication of the companion tone controlled base station and the remote control console. It should be noted that a squelch gate is used in the repeater (RA) station in this guard tone application to give a transmitter channel element ground when the station is keyed. This is necessary since neither an F1-CS or F1-PL control module is used, which would otherwise supply the ground. The squelch gate is NOT used to key the companion base (RA) station.

NOTE

The high level guard tone burst sent by the remote control console should be lengthened to compensate for the delay time encountered in the keying of the guard tone relay station. Refer to the remote control console manual for details.

1. GENERAL

1.1 PURPOSE

The basic functions of remote control is to allow operation of a base station or a repeater station from a remote control point. The station can be located a considerable distance from the control point. However, a compatible remote control console must be used at the control point in order to control the station. Remote control can be done using tones or dc line currents, which are converted into commands that perform such functions as:

- Transmitter turn-on,
- Selection of transmitter and/or receiver frequencies,
- Muting and unmuting receiver audio,
- Disable receiver coded (PL or DPL) squelch.

1.2 DC CONTROL

In systems using dc control functions, a wire line pair, with dc continuity from end-to-end, must be connected between the control point and the station. Each different control function is originated by a dc current through the wire line pair. By varying the dc current polarity and amplitude, it is possible to remotely control several different functions:

- PL disable (receiver),
- Mute receiver #2 audio,
- Unmute receiver #2 audio,
- Turn-on transmitter and select F1 or F2 channel element,
- Turn-on transmitter without PL or DPL encoding (for paging applications).

1.3 TONE CONTROL

In systems using tone control functions, a wire line pair must be connected between the control point and the base station. However, this wire line pair need not possess dc continuity from end-to-end. Each different tone is detected in its own frequency-sensitive circuit and is then converted into a control signal (usually the output of a bistable or other switching device). By generating

and detecting different tones, it is possible to remotely control several different functions:

- PL disable (receiver),
- Turn-on transmitter and select F1 or F2 channel element,
- Mute receiver #2 audio,
- Unmute receiver #2 audio,
- Two settings of squelch,
- Repeater on-off,
- PL on-off,
- Turn-on the transmitter without PL or DPL encoding (for paging applications),
- Four additional on-off functions can be utilized by using a "Wild-Card" to control either relays or solid state switches.

2. DC CONTROL APPLICATIONS

Refer to the simplified and detailed functional block diagrams at the end of this section.

2.1 TRANSMITTER TURN-ON; F1 OSCILLATOR

2.1.1 General

In this application, only one transmitter frequency can be selected. In order to turn on the transmitter and energize the channel element, a +5.5 mA control line current is applied to the line 1 terminals of the remote control chassis, and fed to pins 19 and 20 in the line driver module. This current is then applied to the dc transfer module (pins 3 and 4) and activates the positive transfer oscillator. The positive transfer oscillator output level, which is a function of the dc input level and polarity, is detected within the module and provides low level PTT (pin 10). It also generates, with delayed keyed A+ (pin 17), F1 oscillator ground (pin 14), after a 60 millisecond delay.

2.1.2 Line PTT

Line PTT is applied to the station control module (pin 14), time-out timer (pin 6), squelch gate (pin 16), and F1

tone decoder (pin 19). In the station control module, line PTT initiates three important functions:

- Keyed A+ (pin 8),
- Keyed A- (pin 7),
- Antenna switch-/audio mute (pin 2).

In the time-out timer module, line PTT starts the timing action. In the squelch gate (repeaters only), line PTT inhibits squelch gate operation to give line priority (supervision) over repeater operation. The line PTT input to the F1 tone decoder has no effect unless the station is equipped for both tone *and* dc control. In this case, line PTT resets the PL disable circuit in the F1-PL tone control module.

2.1.3 Keyed A+ and A- Outputs

The keyed A- output of the station control module applies operating voltage to the exciter of the transmitter, but the transmitter is not yet keyed because the channel element is not activated. The keyed A+ output gates the PL encoder output to the desired phase. The antenna switch-/audio mute signal causes the antenna relay to energize, transferring the antenna from the receiver to the transmitter, and mutes receiver audio by disabling the line driver amplifiers.

2.1.4 F1 Channel Element Enable

About 60 milliseconds after PTT is developed at pin 10 of the dc transfer module, F1 oscillator ground (pin 14) is applied to the channel element of the exciter. The 60 millisecond delay allows time for antenna switching before high power transmitted rf energy is applied. Although dc power was applied to the transmitter, the amplifiers are biased Class C and depend upon signal drive from the channel element before rf power output is developed. Grounding the transmitter channel element completes the last step to key the transmitter. Other means of keying the transmitter (locally, repeater, tone control) are described later.

2.2 TRANSMITTER TURN-OFF

2.2.1 General

Transmitter turn-off is a sequence of steps which allow transmission of the reverse burst PL signal (tone *Private-Line* stations) or turn-off code (*Digital Private-Line* stations), shut-down of rf power, and finally, antenna switchover to the receiver.

2.2.2 Reverse Burst PL Transmission

When positive line current is removed, the line PTT signal immediately reverts to a high. However, the delayed keyed A+ signal (at pin 17 of dc transfer module) continues for approximately 180 milliseconds. During this

180 millisecond period, F1 oscillator ground is still provided to keep the transmitter keyed.

Loss of the line PTT signal causes the keyed A+ output of the station control module (pin 8) to be removed. This causes the PL encoder-decoder to shift the phase of the PL tone for the reverse burst transmission, or the DPL encoder-decoder to transmit the turnoff code. In non-PL stations, the transmitter also continues to operate for 180 milliseconds.

2.2.3 RF Shut-Down

Keyed A- (station control pin 7) continues to be provided, as long as delayed keyed A+ is present.

Upon the loss of delayed keyed A+ and F1 oscillator ground (180 milliseconds after dc line current is removed), the transmitter shuts down because of loss of channel element ground and keyed A- power.

2.2.4 Antenna Switchover

Upon the loss of keyed A-, the antenna switch-/audio mute circuit starts a 30 millisecond turn-off delay. At the end of this 30 millisecond period, the low at pin 2 of the station control module reverts to a high. This de-energizes the antenna relay and unmutes receiver audio, placing the station in the standby condition.

If the transmitter is keyed beyond the time duration set in the time-out timer, a T-O-T key inhibit signal (pin 4 of the T-O-T) inhibits keyed A- in the station control module to start shut down of the transmitter. This allows the 30 millisecond delay before antenna switchover.

2.3 TRANSMITTER TURN-ON: F2 OSCILLATOR

In two-frequency transmitter applications, a different channel element is selected for each operating frequency. In order to turn on the transmitter and select the second (F2) channel element a +12.5 mA control line current is applied to pins 19 and 20 in the line driver module. This current is then applied to the dc transfer module (at pins 3 and 4) and activates the positive transfer oscillator. The positive transfer oscillator output level, which is a function of the dc input level and polarity, is detected within the module. The detection results in a low level line PTT (pin 10) and an F2 oscillator ground output (pin 16). Circuit operation from this point on is the same as described for transmitter turn-on with F1 oscillator except that a ground is provided to the F2 channel element of the transmitter.

2.4 RECEIVER #2 MUTE

In this application, receiver #2 can be muted independent of any other operation. A momentary -5.5 mA control line current is applied to pin 19 and 20 in the line

driver module. This current is then applied to the dc transfer module (at pins 3 and 4) to activate the negative transfer oscillator. The negative transfer oscillator output is detected within the module and provides an R2 mute output at pin 20 to mute receiver #2 audio in the line driver module. Receiver #2 audio remains muted until the transmitter turn-on F2 oscillator function is activated at which time the R2 mute function is no longer generated.

2.5 RECEIVER PRIVATE-LINE DISABLING

In this application, the receiver *Private-Line* coded squelch circuit is disabled prior to the transmission for channel monitoring purposes. A -2.5 mA control line current is applied to pins 19 and 20 in the line driver module. This current is then applied to the dc transfer module (at pins 3 and 4) to activate the negative transfer oscillator. The negative transfer oscillator output is detected within the module and produces a low PL disable control output. The low is inverted to a high in the station control module (pin 23), from which it is applied to the receiver (both receivers in 2-receiver stations). The PL disable control output remains active until the transmitter is keyed by one of the dc control applications described above. Immediately after the control point furnishes the transmitter turn on command, the PL disable control output reverses and again enables the receiver PL-coded squelch circuit.

2.6 C2-R2 FREQUENCY SELECTION

Stations equipped with a two-frequency receiver and a two-frequency transmitter use a C2-R2 dc transfer module which selects a receiver channel element whenever selecting a transmitter channel element (paired switching). A +5.5 mA line current selects the F1 oscillator ground described for transmitter turn-on. It also activates an R1 bistable which provides an R1 oscillator ground (pin 21 of dc transfer module) which is routed to the R1 channel element in the receiver.

A +12.4 mA line current selects F2 oscillator ground for the transmitter as described previously. It also activates an R2 bistable which provides an R2 oscillator ground (pin 22 of dc transfer module) which is routed to the R2 channel element in the receiver.

The R1 and R2 bistables are mutually resetting so that only one can be activated at any given time. Unlike the F1 and F2 bistables, the R1 and R2 bistables do not turn off when the dc control current is removed, but remain in the selected state until changed.

2.7 PAGING (TRANSMITTING WITHOUT PL)

In this application, the transmitter can be keyed with or without PL coded modulation. To transmit with PL coded modulation, a +5.5 mA line current is applied which turns on the transmitter (F1) as described previ-

ously. To transmit without PL coded modulation, a -2.5 mA line current is applied. The dc transfer module converts this command to line PTT and F1 oscillator ground as described previously, but it also places a low on the page output (pin 20). This low signal is routed to XMIT PL INHIBIT (pin 14) of the coded squelch modules in paging stations. This permits the PL encoder output to be inhibited while a low is provided from the paging control module.

2.8 REPEATER TRANSMITTER TURN-ON

A repeater transmitter is turned on by the squelch gate module. Discriminator output from the receiver is applied to the squelch gate (pin 10). A quieted signal (reduced noise because of an incoming rf signal) actuates the squelch gate, which in turn, keys the transmitter for retransmission of the audio. In PL stations, a PL indicator (pin 14) is also required before the module is activated (correct PL tone must be decoded to produce the PL indicator signal).

The output of the squelch gate module, repeater PTT (pin 18) is applied to the station control module (pin 15). This input produces PTT control (pin 10), keyed A+ (pin 8), keyed A- (pin 7) and inhibits antenna switch/audio mute (pin 2). The PTT control signal is applied to the dc transfer module to activate the F1 oscillator. The remainder of transmitter turn-on and turn-off circuit operation is as described for remote control base stations.

In a non-wire line controlled repeater, jumpers JU5 and JU6 in the squelch gate module are connected, which permits keyed A+ from the station control module to enable channel element switch Q8. Q8 provides the F1 oscillator ground. In this mode, transmitter turn-off uses delayed keyed A+, from the *Private-Line* encoder, to provide delayed keyed A+ (pin 7 of squelch gate).

Receiver audio is gated through the squelch gate module (pin 17 input, pin 11 output) to the exciter. The exciter audio path through the station control module is inhibited by audio gate driver Q6 when the PTT control signal is low.

2.9 REPEATER SET-UP AND KNOCKDOWN

Repeater stations may be equipped for wire line control from the remote control point. This permits the repeater function to be disabled (knocked down) for base operation. Line operation has priority over repeater operation. Line keying produces a line PTT input (pin 14, station control module) which inhibits the PTT control signal (pin 10) as well as inhibiting the squelch gate (pin 16).

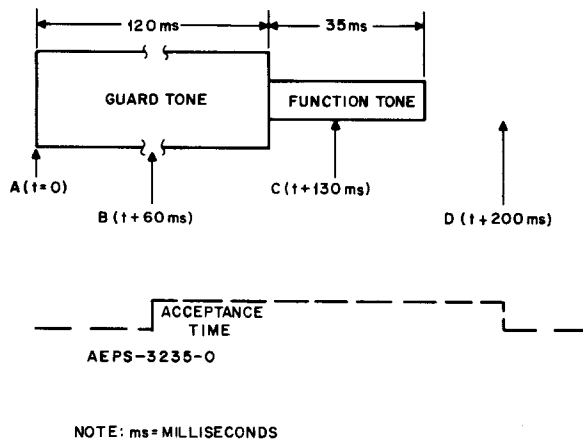

Figure 1. Tone Control Format, Non-Transmit Command

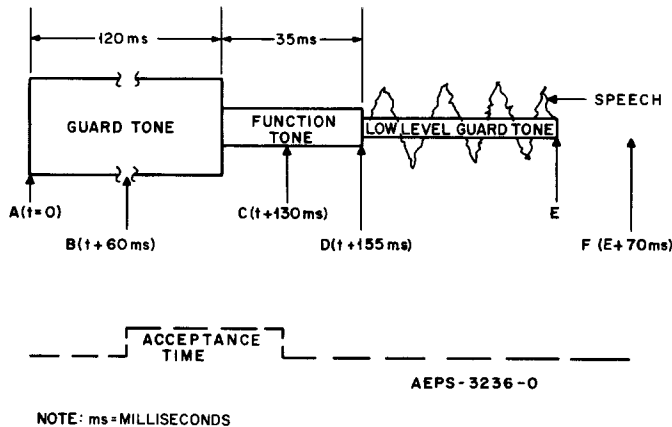

Figure 2. Tone Control Format, Transmit Command

2.9.1 Repeater Set-Up

In this application, an enabling +12.5 mA control current is generated that allows the repeater to operate. Repeater turn-on (repeater set-up) is similar to transmitter turn-on F2 oscillator except:

- A high level repeater set-up output is provided at pin 20 of the dc control module,
- Jumpers are connected so that pin 20 (of the dc control module) is connected to pin 21 of the squelch gate module,

- The squelch gate module provides a repeater PTT output at pin 8. This output is applied to the station control repeater PTT at pin 15 (instead of line PTT at pin 14) to key the transmitter.

2.9.2 Repeater Knockdown

The -5.5 mA repeater turn-off current causes operation similar to Receiver #2 Mute except the low output at pin 20 is applied to pin 21 of the squelch gate module. This low input at pin 21 inhibits the repeater PTT circuits in the squelch gate module.

3. TONE CONTROL APPLICATIONS

Refer to the simplified and detailed functional block diagrams at the end of this section.

3.1 TONE CONTROL FORMAT

In all tone control applications, tones are sent from the control point in a particular timing sequence (tone control format). All tones must be preceded by a 2175 Hz guard tone. The guard tone is used to activate circuits which detune a 2160 Hz bandpass filter in the guard tone decoder module. With the 2160 Hz bandpass detuned, all tones can pass through the guard tone decoder and then be routed to their respective decoders. The tone control format is shown in Figures 1 and 2.

As shown in Figures 1 and 2, there are two distinct types of commands; transmit commands, and non-transmit commands. A 2175 Hz guard tone always precedes the function tone(s); however, in the case of transmit commands the guard tone continues (at a 30 dB lower level) in order to keep the transmitter keyed.

3.2 TRANSMITTER TURN-ON; F1 OSCILLATOR

3.2.1 General

In this application, only one transmitter frequency can be selected. In order to turn on the channel element, the F1 transmit command format (2175 Hz guard tone followed by 1950 Hz F1 function tone) is applied to pins 19 and 20 in the line driver module. The tones are then routed out of the line driver module on pin 10 and are applied to pin 9 of the guard tone decoder.

3.2.2 Line PTT

The guard tone decoder detects the 2175 Hz guard tone and uses a portion of the detected voltage to effectively disconnect the 2160 Hz bandpass filter at the guard tone decoder input. In addition, the guard tone decoder also provides a line PTT output at pin 16 and a decoder bias output at pin 15; both resulting from the 2175 Hz tone.

The line PTT output at pin 16 is used as described for dc controlled stations, energizing the antenna relay and

muting receiver audio, and applying keyed A- to the transmitter.

The 2175 Hz guard tone signal continues to be received as long as the transmitter is being keyed; however, the level is decreased by 30 dB. Circuits within the guard tone decoder compensate for the lower guard tone level and insure that line PTT output is provided even during the lower level input.

3.2.3 F1 Channel Element Enable

With the 2160 Hz bandpass filter disconnected, the F1 function tone (1950 Hz), which follows the high level guard tone, is allowed to pass through the guard tone decoder via the function HI output at pin 11. The 1950 Hz portion of the signal is applied to the F1-PL (or F1-CS) module for detection. (Although the 1950 Hz tone is applied to other modules, it can only be detected in the F1-PL or F1-CS module.) When the 1950 Hz tone is detected in the F1-PL module, the F1 bistable produces a low F1 Osc output at pin 3 which provides a ground enable for the transmitter F1 channel element to completely key the transmitter.

3.2.4 Function Tone Enable

In order for the tone detector circuits to function, an enable signal must be provided during the control format time. This signal originates in the guard tone decoder module as the decoder bias output at pin 15 and is the result of guard tone detection. The decoder bias signal is a high-level, 350 millisecond window that is applied to the F1-CS tone decoder (pin 15). The F1-CS module converts the signal to a low-level function enable output at pin 20. The 350 millisecond low-level function enable is applied to pin 13 of all of the tone detector circuits (in four different tone control module positions) so that tones can only be detected during the 350 millisecond window.

3.3 TRANSMITTER TURN-OFF

3.3.1 General

When low level 2175 Hz guard tone ends, transmitter turn-off begins. First, the guard tone loss is detected by activity checker Q20 in the guard tone decoder. After a 75 millisecond turn-off delay, the line PTT output (pin 16) reverts to a high.

3.3.2 Reverse Burst PL Transmission

Loss of the line PTT causes loss of keyed A+ in the station control module (pin 8). In turn, loss of keyed A+ starts the PL reverse burst transmission (turn off code in a digital system) via the *Private-Line* encoder. The PL encoder provides delayed keyed A+ for an additional 180 milliseconds while the reverse burst or turn-off code is transmitted. The delayed keyed A+ keeps

the F1 bistable on (F1-PL module) to continue providing F1 channel element ground.

3.3.3 RF Shut-Down

After the 180 millisecond reverse burst period, delayed keyed A+ is removed, which turns off the F1 bistable and removes keyed A-. This turns off the channel element which removes the signal drive to the Class C rf amplifiers.

3.3.4 Antenna Switchover

30 milliseconds after keyed A- is removed, the antenna switch-/audio mute signal (station control, pin 2) allows the antenna relay to de-energize and unmutes audio in the line driver.

3.4 TRANSMITTER TURN-ON; F2 OSCILLATOR

3.4.1 F2 Control

In this application a different transmit channel element is selected for each of the two operating frequencies. In order to turn on the transmitter and select the second (F2) channel element, the transmit command format (2175 Hz guard tone followed by 1850 Hz F2 function tone) is applied to pins 19 and 20 in the line driver module. From this point the circuit operation is the same as that described for F1 selection except that the F2 channel element is selected by detection of the 1850 Hz tone in either the C2-R2, F2-R2 Mute, or F2-Control Module. The low level (ground) F2 channel element output at pin 4 is then applied to the transmitter.

3.4.2 Paging Control

When the station is equipped with an option decoder-paging control module instead of an F2-control module, the 1850 Hz command keys the transmitter on F1 and prevents transmission of the *Private-Line* code. The 1850 Hz command is detected in the paging control module by Q1, which sets paging disable bistable Q2, Q3. The Q output of the bistable provides a PL inhibit output which prevents *Private-Line* code from being generated.

- The F2 output has no effect since the transmitter is not equipped with an F2 channel element.
- The local F1 output is applied to the F1 tone control module, which activates the F1 bistable and keys the transmitter on frequency F1.

3.5 RECEIVER *PRIVATE-LINE* DISABLING

3.5.1 General

In this application a transmit channel element is not selected, therefore, the transmitter is not keyed. In order

to generate a PL disable signal, the non-transmit command format (2175 Hz guard tone followed by 2050 Hz PL disable function tone) is applied to pins 19 and 20 in the line driver module. The tones are then routed out of the line driver module on pin 10 and are applied to pin 9 of the guard tone decoder.

The guard tone decoder detects the 2175 Hz guard tone and uses a portion of the detected voltage to effectively disconnect the 2160 Hz bandpass filter at the guard tone decoder input. In addition, the guard tone decoder provides a bias output at pin 15 which is the result of the 2175 Hz tone. (A line PTT is also generated, however, it cannot key the transmitter because a channel element is not selected.)

3.5.2 PL Disable Function

With the 2160 Hz bandpass filter disconnected, the PL disable tone (2050 Hz) passes through the guard tone decoder via the function HI output at pin 11. The 2050 Hz signal is applied to the F1-PL module for detection. (Although the 2050 Hz tone is applied to other modules, it can only be detected in the F1-PL module.) When the 2050 Hz signal is detected in the F1-PL module, the PL disable bistable provides a low level PL disable control output at pin 21. The low level PL disable control is applied to the station control module at pin 20. This results in a high level PL disable output, at pin 23, to disable the *Private-Line* operation of the receiver for channel monitoring before transmission. The PL disable condition remains until a line PTT input is applied to pin 19 (which occurs when the transmitter is next keyed).

3.5.3 Function Tone Enable

In order for the tone detector to function, the guard tone decoder generates a 350 millisecond, high-level, decoder bias signal (at pin 15). The decoder bias signal originates via 2175 Hz guard tone detection and is present during the 350 millisecond time period that follows. The F1-PL module converts the decoder bias signal into a 350 millisecond, low-level, function enable signal that enables the detectors within the module during the 350 millisecond window. In addition, the function enable is also applied to other modules so that their detectors can also function during the 350 millisecond window.

3.6 R2 MUTE OR RECEIVE F1

In this application, a transmit channel element is not selected, therefore, the transmitter is not keyed. In order to generate the R2 mute signal, the non-transmit command format (2175 Hz guard tone followed by a 1750 Hz R2 mute function tone) is applied to pins 19 and 20 in the line driver module. The tones are then routed out of the line driver module on pin 10 and are applied to pin 9 of the guard tone decoder.

Circuit operation from pin 9 of the guard tone decoder is similar to that previously described for receiver *Private-Line* disabling except:

- Either the C2-R2 control module, or the F2-R2 mute control module detects the tone.
- The R2 mute output is applied to the line driver.

When the 1750 Hz R2 mute function tone is detected in the control module (C2-R2, or F2-R2 mute) the R2 mute bistable provides a low level R2 mute output at pin 7. This output is applied to the line driver module. The R2 mute signal disables the R2 audio line in the line driver.

If the C2-R2 module is used, the R2 mute bistable also initiates a low level (ground) output at pin 15 to activate the receiver F1 oscillator.

3.7 R2 UNMUTE OR RECEIVE F2

In this application, a transmit channel element is not selected, therefore, the transmitter is not keyed. In order to generate the R2 unmute signal, the non-transmit command format (2175 Hz guard tone followed by a 1650 Hz R2 unmute function tone) is applied to pins 19 and 20 in the line driver module. The tones are then routed out of the line driver module on pin 10 and are then applied to pin 9 of the guard tone decoder.

Circuit operation from pin 9 of the guard tone decoder is similar to that previously described for receiver *Private-Line* disabling except:

- Either the C2-R2 control module, or the F2-R2 mute control module detects the tone.
- The R2 mute output is open circuited.

When the 1650 Hz R2 unmute function tone is detected in the control module (C2-R2 or F2-R2 mute), the R2 unmute bistable provides a cross-coupling to the F2 mute bistable. This causes the F2 mute bistable to open circuit the F2 mute output which, in turn, removes the F2 mute input to line driver. This allows R2 audio to pass through the line driver R2 audio line.

If the C2-R2 module is used, the R2 unmute bistable also initiates a low level (ground) output at pin 17 to activate the receiver F2 oscillator.

3.8 "WILD-CARD" ON-OFF

The optional "Wild Card" function tone decoder provides up to four solid state low-high switched outputs or optional relay contact closure outputs. Four different function tones are used to control the four circuits. Each circuit is identical, therefore, only one of the four is described, the 1050 Hz circuit. (The others are 1150 Hz, 1250 Hz, and 1350 Hz.) The 1050 Hz function tone is

applied to the line driver pins 19 and 20 in the non-transmit command format (2175 Hz guard tone followed by a 1050 Hz function tone). They are routed out of the line drive module on pin 10 and are applied to pin 9 of the guard tone decoder.

Circuit operation from pin 9 of the guard tone decoder is similar to that previously described for receiver *Private-Line* disabling except:

- The tone is detected in the "Wild Card" module.
- The output is either a relay contact or bistable output.

When the 1050 Hz function tone is detected in the "Wild Card" module, the #1 bistable provides a ground output at the Q side. This ground is normally applied through JU1 to pin 3 where it can be used as a control line. If a relay is used, JU1 is disconnected and the relay contacts are connected to the control line.

3.9 REPEATER SET-UP

In this application, the repeater keying circuits are enabled, thus allowing the repeater to be keyed by the squelch gate module. In order to generate a repeater turn-on enable signal, the non-transmit command format (2175 Hz guard tone followed by a 1450 Hz repeater-on function tone) is applied to pins 19 and 20 in the line driver module. The tones are then routed out of the line driver module on pin 10 and are applied to pin 9 of the guard tone decoder.

The guard tone decoder detects the 2175 Hz guard tone and uses a portion of the detected voltage to effectively disconnect the 2160 Hz bandpass filter at the guard tone decoder input. In addition, the guard tone decoder provides a 350 millisecond decoder bias output signal, at pin 15, which is the result of the 2175 Hz tone.

With the 2160 Hz bandpass disconnected, the repeater turn-on function tone (1450 Hz) passes through the guard tone decoder via the function HI output at pin 11. The 1450 Hz function tone is applied to the repeater control option decoder module for detection. When the 1450 Hz function tone is detected, the repeater turn-on bistable is set and the low Q output is cross-coupled to the clear side of the repeater turn-off bistable. The cross-coupling produces a high level output signal at pin 9. Because this output signal is high, the function becomes repeater turn-on, instead of repeater turn-off.

The high output signal from pin 9 of the repeater control is applied to pin 21 of the squelch gate module. This high level is an enabling input, which allows the squelch gate module to produce the repeater PTT output signal, at pin 18, when the receiver quiets, due to an incoming rf signal.

3.10 REPEATER TURN-OFF

In this application, the repeater keying circuits are disabled in order to generate the repeater turn-off function. The circuit operation is similar to that described for repeater turn-on except:

- A 1550 Hz repeater turn-off function tone is used.
- When the repeater control module detects the 1550 Hz repeater turn-off function tone, it generates a low output signal, at pin 9, that disables the repeater keying function, preventing the repeater from being keyed.

3.11 MAX SQUELCH AND MIN SQUELCH

In these two applications, an attenuator is either switched in or out of the squelch control circuit. The squelch control option decoder module is used in place of the repeater control option decoder module and is the same except that only jumper JU2 is connected. Circuit operation for this application is similar to that previously described for repeater turn-on and turn-off except:

- When a 1450 Hz min squelch function tone is detected, the turn-on bistable switches the attenuator into the circuit for threshold squelch.
- When a 1550 Hz max squelch function tone is detected, the turn-off bistable cross couples to the turn-on bistable which then switches the attenuator out of the circuit for maximum squelch.
- The squelch attenuator output signal, at pin 18, reflects the condition of the attenuator squelch ratio changes.

3.12 RECEIVER PL ON - PL OFF

In these two applications the type of squelch is selected; *Private-Line* coded squelch or carrier squelch. The *Private-Line* control option decoder module is used instead of the repeater control option decoder module, and only jumpers JU3 and JU4 are connected. Circuit operation for this application is similar to that previously described above for repeater turn-on and turn-off except:

- When a 1450 Hz PL off function tone is detected, the operate carrier squelch bistable provides a low output signal on pin 20 (high on pin 5) which disables the receiver PL coded squelch circuit.
- When a 1550 Hz PL on function tone is detected, the operate PL bistable provides a low output signal on pin 5 (high on pin 20) which enables the receiver PL coded squelch circuit.

The low PL disable output signal on pin 20 (pin 5 high) is applied to the station control module pin 5. This produces a high PL disable output signal from this module, at pin 23, to disable the PL and change operation to the carrier squelch mode.

The low PL enable output signal on pin 5 is applied to the F1-PL module to produce high PL disable and function enable output signal from this module. This insures that no other function tones can be excepted and that operation remains in the PL mode.

3.13 SINGLE-TONE DECODER

The single-tone decoder module may be used in repeater systems to key a specific repeater. The single-tone decoder can detect one of 19 different audio frequencies between 600 and 3300 Hz, with a 150 Hz spacing. The input, containing the particular function tone, is applied from the receiver at pin 3 of the single-tone decoder module. The module detects the function tone and removes the ground output at pin 16 (squelch gate inhibit). This removes the inhibiting function from the squelch gate module allowing it to function normally. The single-tone decoder module is reset by the squelch gate module upon loss of received rf carrier signal. The single-tone decoder can also be used for receiving enabling. Switched A+ output is applied to the PL indicator output of the receiver, enabling the receiver squelch circuit only when the proper single-tone frequency has been received. The PL disable function may be used for monitoring the channel.

3.14 FOUR-FREQUENCY SELECTION

3.14.1 General

The 4-frequency control option decoder module converts a function tone signal from a remote source to a switched ground function for transmit and receive channel element selection. The function tone is applied to a clipper amplifier and passed to resonant tank circuits which are tuned to respond to a specific frequency: 1250 Hz, 1350 Hz, 1850 Hz, or 1950 Hz.

The function tone signal passes through the resonant tank circuit to a detector circuit where it is converted, upon application of a function enable signal from the guard tone decoder module, from a function tone to a dc voltage. This dc signal is inverted and applied to the transmit and receive latches. These latches, upon application of a clock pulse, activate the channel element drivers to provide a switched ground to the selected transmit and receive channel elements.

3.14.2 Transmit Frequency Selection

Since all frequency selection circuits are the same except for the specific frequency to which they respond, only one circuit is described, the F2 (1850 Hz) circuit. When

an 1850 Hz function tone is sent from the remote control console, it is received at pin 11 of the four-frequency control option decoder module. It is then amplified and passed through the respective tank circuit. The signal is detected by the F2 detector and is converted from a 1850 Hz function tone to a logic low dc voltage. The F2 detector is enabled by the presence of the function enable signal at pin 13 from the bias switch in the F1-CS or F1-PL tone control module. This signal is developed only after the high level guard tone has been detected.

The logic low F2 detector output is inverted and applied to transmit latch flip-flop U11B and to the transmit latch clock. The clock pulse is applied to the F2 flip-flop which changes state and produces a high level Q output. This output is inverted to a logic low and is applied to the T2 transmitter channel element. As this happens, the other transmit latch flip-flops reset, cancelling any previous frequency selection.

3.14.3 Receive Frequency Selection

The logic high from the F2 transmit latch flip-flop is also applied to the receiver latch clock circuit and receiver latch flip-flop U2B. The receiver latch clock sends a pulse to receiver latch flip-flop U2B which causes the Q output to become high. The receiver latch flip-flop now remains in this state until reset. AND gate U3B applies a high to inverter Q23. The output of Q23 is a ground which selects the R2 receiver channel element.

After transmission has been completed and PTT has been released, SW 9.6 V is removed from pin 8, causing C14 to discharge. The discharge of this capacitor turns on the transmit clock causing a second pulse to be applied to the multivibrator which resets the transmit latch back to its original state (all Q outputs low).

The receiver latch does not reset after transmission has been completed. The receiver channel, in this explanation R2, remains activated. When transmission is changed to F1, F3, or F4, the receiver clock will pulse the receiver latch flip-flop, thus resetting R2 and turning on the appropriate receiver channel frequency for proper communications.

The power on reset circuit pulses receiver latch flip-flop U2A, resetting the multivibrator to select the R1 channel element select any time power is lost, due to removal of the card, or power outage.

4. EXCITER AUDIO

Exciter audio is defined as the audio used to modulate the transmitter. It is applied to the transmitter and can originate from several sources depending upon the modules that are used in the station.

Audio from the remote control point is applied to pins 19 and 20 of the line driver module, and is routed out of this module on pin 24. From this point, the audio is applied to pin 6 of the station control module for level control setting and gating (must be gated by PTT control). The audio leaves this module at pin 16 (as unnotched mic HI). From the station control module, it is applied to control metering connector J2, pin 7, and the F1-PL (or F1-CS) module, pin 18. The F1-PL module contains a notch filter that greatly attenuates any 2175 Hz guard tone signals present to insure that a guard tone is not transmitted "on-the-air". After filtering, the exciter audio HI output from the F1 tone control module at pin 22, is applied to the exciter, via J102-12.

5. RECEIVE AUDIO

Receiver R1 or R2 detected audio output is routed (via J202-5 or J302-5, respectively) to the line driver module at pins 13 and 22, respectively. (R1 detected audio is first routed through the R1 audio & squelch module for processing and switching. R2 detected audio is first routed through the R2 audio & squelch module for processing and switching.) In repeater operation, R1 detected audio is applied to the squelch gate module, at pin 17.

Any receive audio is routed through the line driver module; however, the output point depends upon the module used and the jumper connections.

Normally, receive audio is routed through the line 1 level set control, line amplifiers, and exists on pins 19 and 20.

The wire line pair carries this audio back to the remote control point.

R1 detected audio may be routed to the line 1 output while R2 detected audio may be routed through the line 2 level set control, line amplifiers, and exit the module on pins 7 & 8. Both wire line pairs carry audio to a remote point.

The detected audio from the receiver(s) can be routed to the line 2 output, when line 1 is to be used for transmit audio and line 2 is to be used for receive audio.

In tone controlled stations, R1 detected audio is routed from the receiver, through the F1-PL tone control module which contains a 2175 Hz receive notch filter (to remove any 2175 Hz guard tone), then to the line driver module.

Any audio that is routed to line 1 or line 2 is sampled from the line transformer and exists the line driver module on pin 23. This audio is routed to the audio power amplifier of the R1 audio & squelch module for local speaker audio.

In repeater configurations, R1 detected audio is applied to pin 17 of the squelch gate module for gating and level setting. The audio output at pin 11 (repeat audio) is then routed to the exciter, via J102-12, for repeat transmission.

TRANSMITTER KEYING

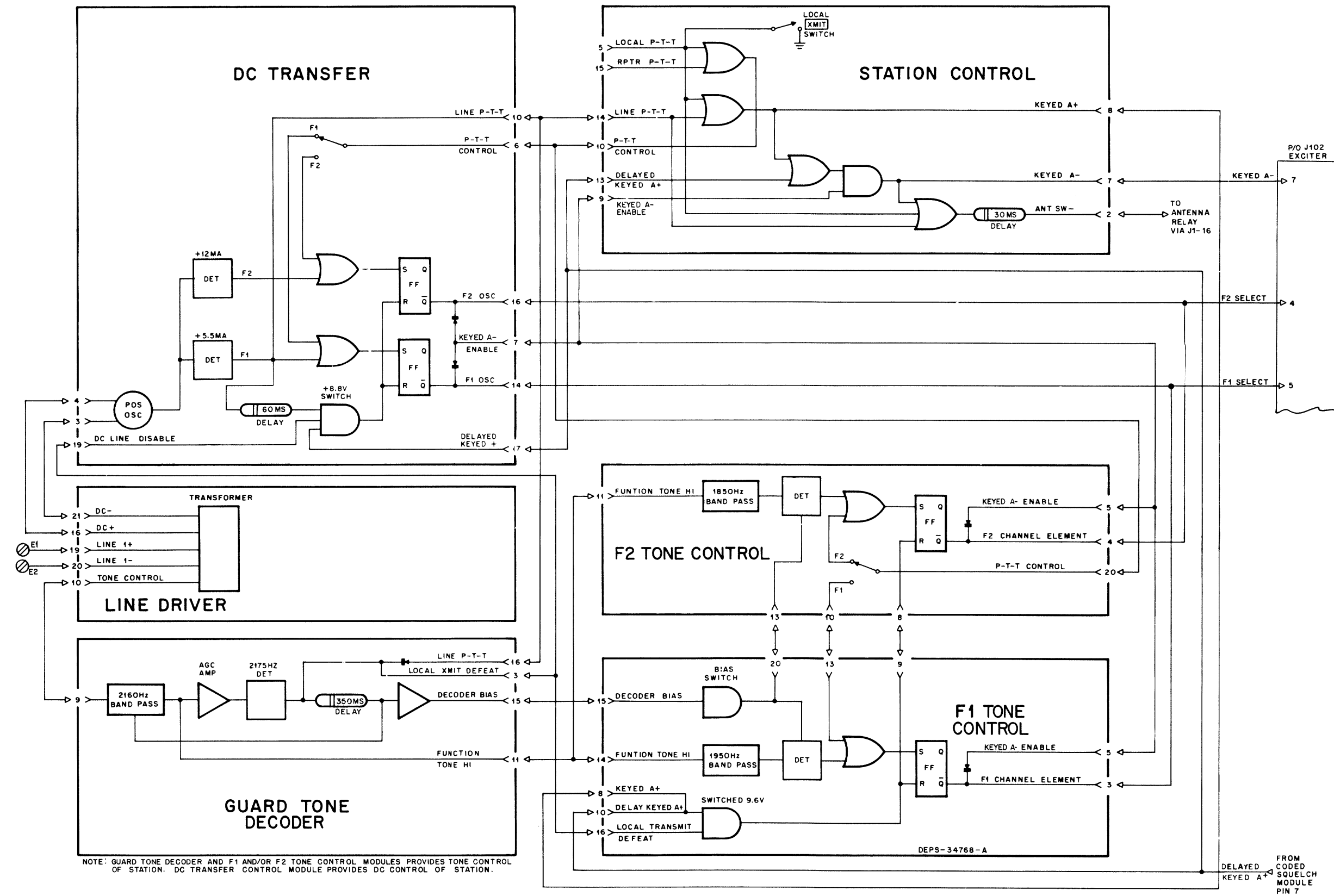

STATION AUDIO

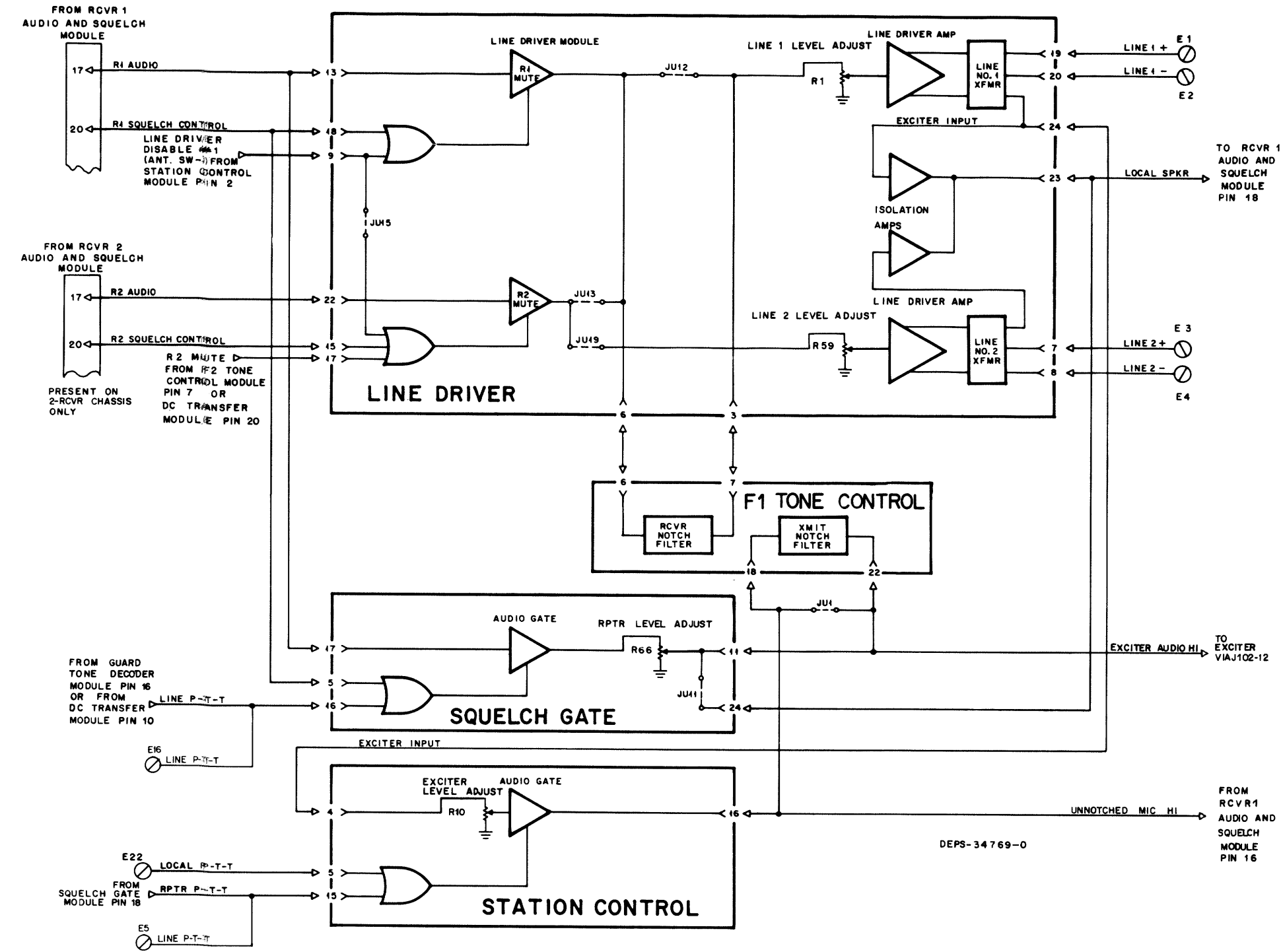

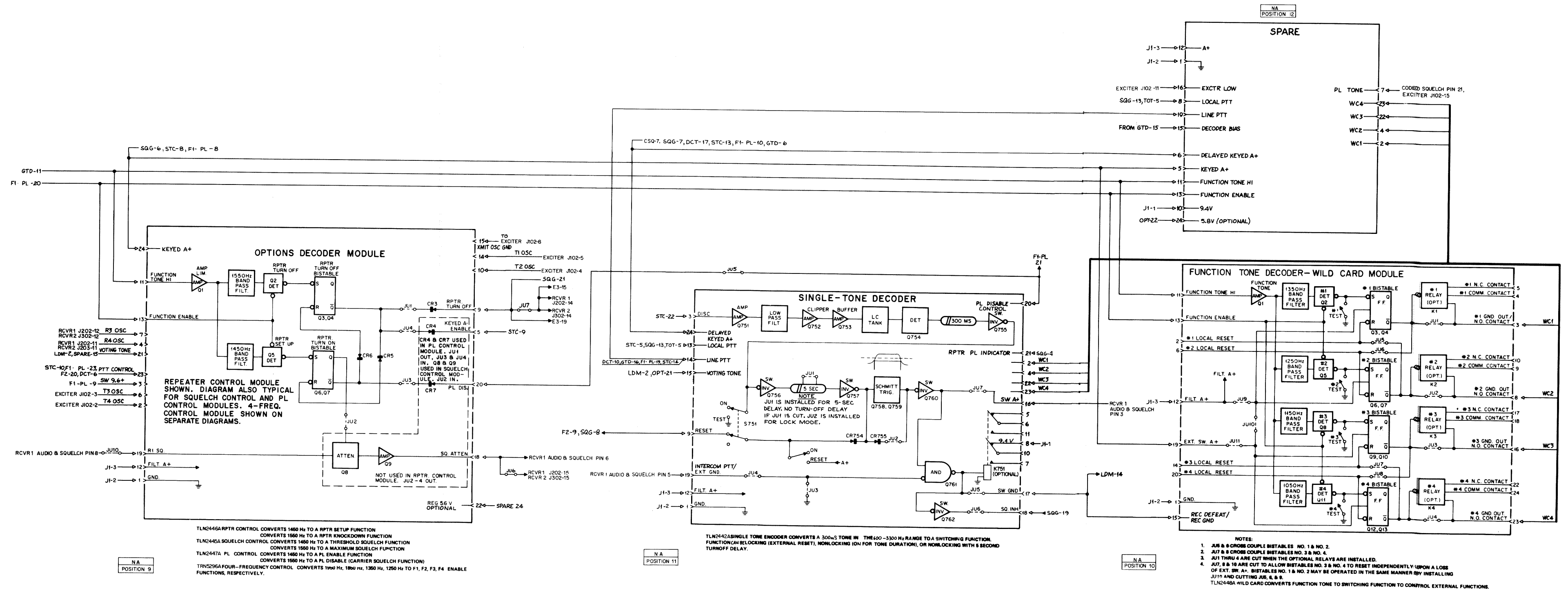

Functional Block Diagrams
Detailed 1 & 2 Frequency Stations
Motorola No. PEPS-34773-A
(Sheet 2 of 5)

TRN 5234A FOR 4-WIRE AUDIO, 1 OR 2 RCVR
TRN 5236A 2-WIRE AUDIO, 1 RCVR
TRN 5237A 2-WIRE AUDIO, 2 RCVR
COUPLES REC AUDIO TO LINE AND LOCAL SPKR
COUPLES LINE XMT AUDIO TO XMTDR INPUT
REC AUDIO MAY BE MUTED AND LINE DRIVE MAY BE DISABLED

TRN 5231A STATION CONTROL, CONTROLS XMT KEYING, PL DISABLING, AND LINE DISABLING; AMPLIFIES XMT
AUDIO AND REC DRVR AUDIO

TRN 5255A C2-R2 (SHOWN) +5.5 mA KEYS XMTDR ON F1, SELECTS R1, +12.5 mA KEYS XMTDR ON F2, SELECTS R2, -2.5 mA DISABLES RECEIVER PL OR
TRN 5254A F1 -5.5 mA KEYS XMTDR ON F1
TRN 5254A F2 -5.5 mA KEYS XMTDR ON F2 AND UNMUTES R2, -2.5 mA DISABLES RECEIVER PL
-5.5 mA MUTES R2 ON
TRN 5257A RPTDR CONTROL, +5.5 mA KEYS XMTDR ON F1, +12.5 mA ENABLES REPEATER OPERATION, -2.5 mA DISABLES RECEIVER PL, -5.5 mA
DISABLES REPEATER OPERATION OR
TRN 5259A PAGING, +5.5 mA KEYS XMTDR ON F1 WITH PL MODULATION, -2.5 mA DISABLES RECEIVER PL, -12.5 mA KEYS XMTDR ON F1
WITHOUT PL MODULATION

C2-R2 DC TRANSFER MODULE SHOWN
OTHER DC TRANSFER MODULE VARIATIONS
SHOWN ON SEPARATE DIAGRAM.

TRN 5234A SQUELCH GATE PROVIDES TRANSMITTER TURN ON WHEN NOISE DROPS BELOW THRESHOLD 110-25 dB QUIETING;
IN PL MODEL, CORRECT CODE IS ALSO REQUIRED.

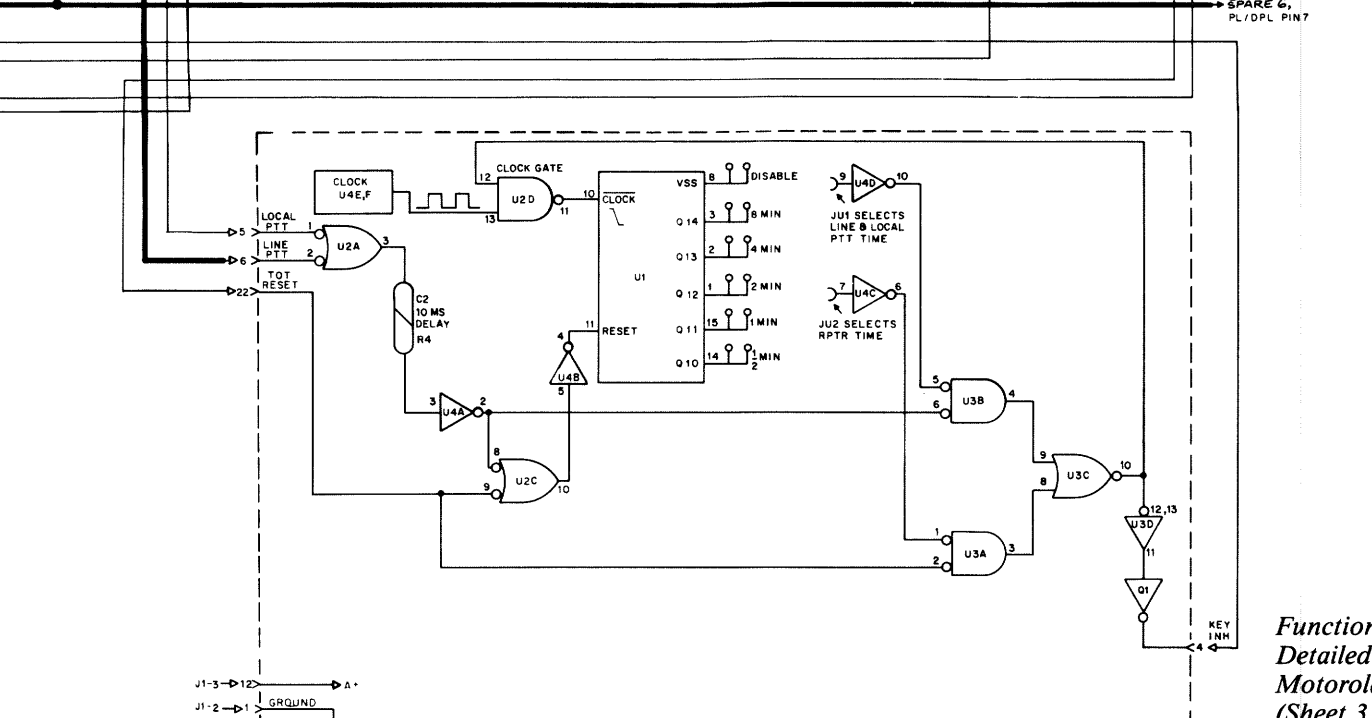
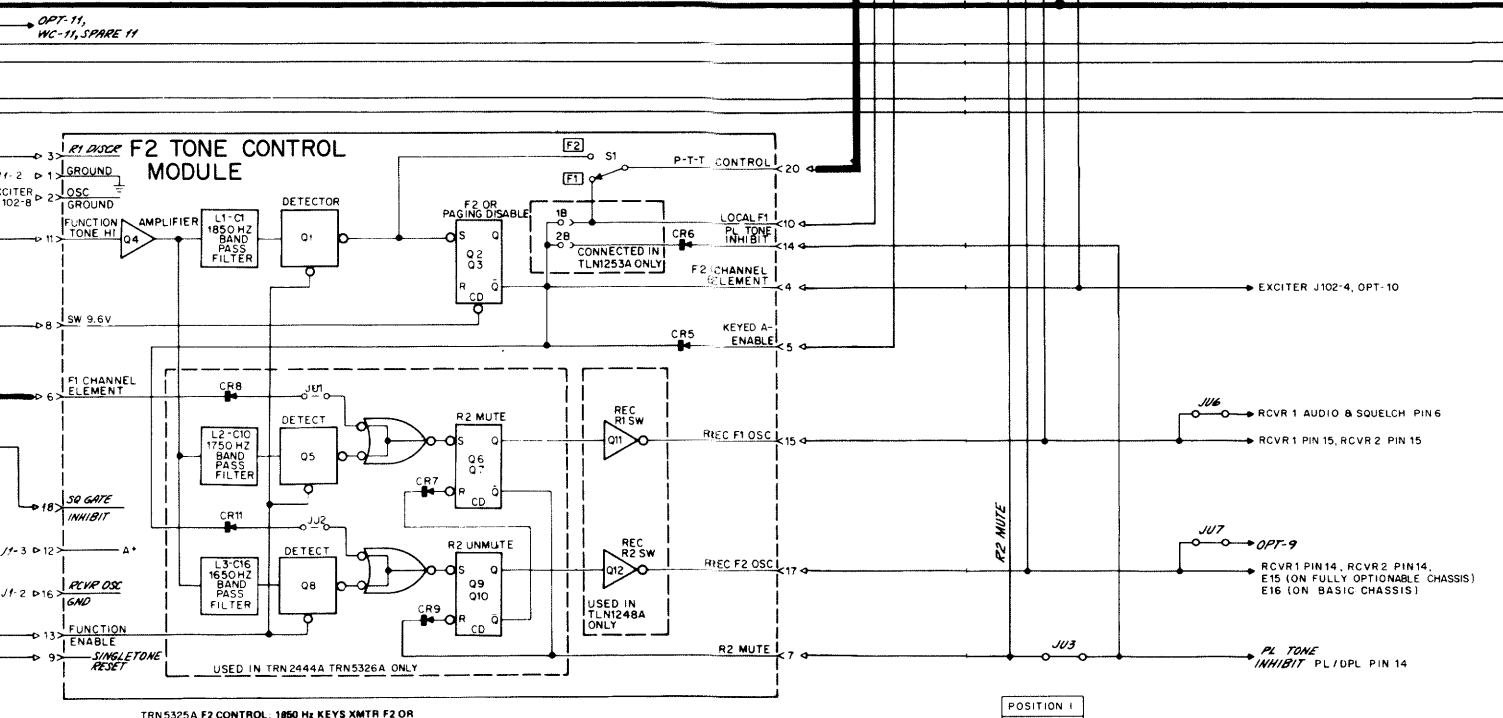
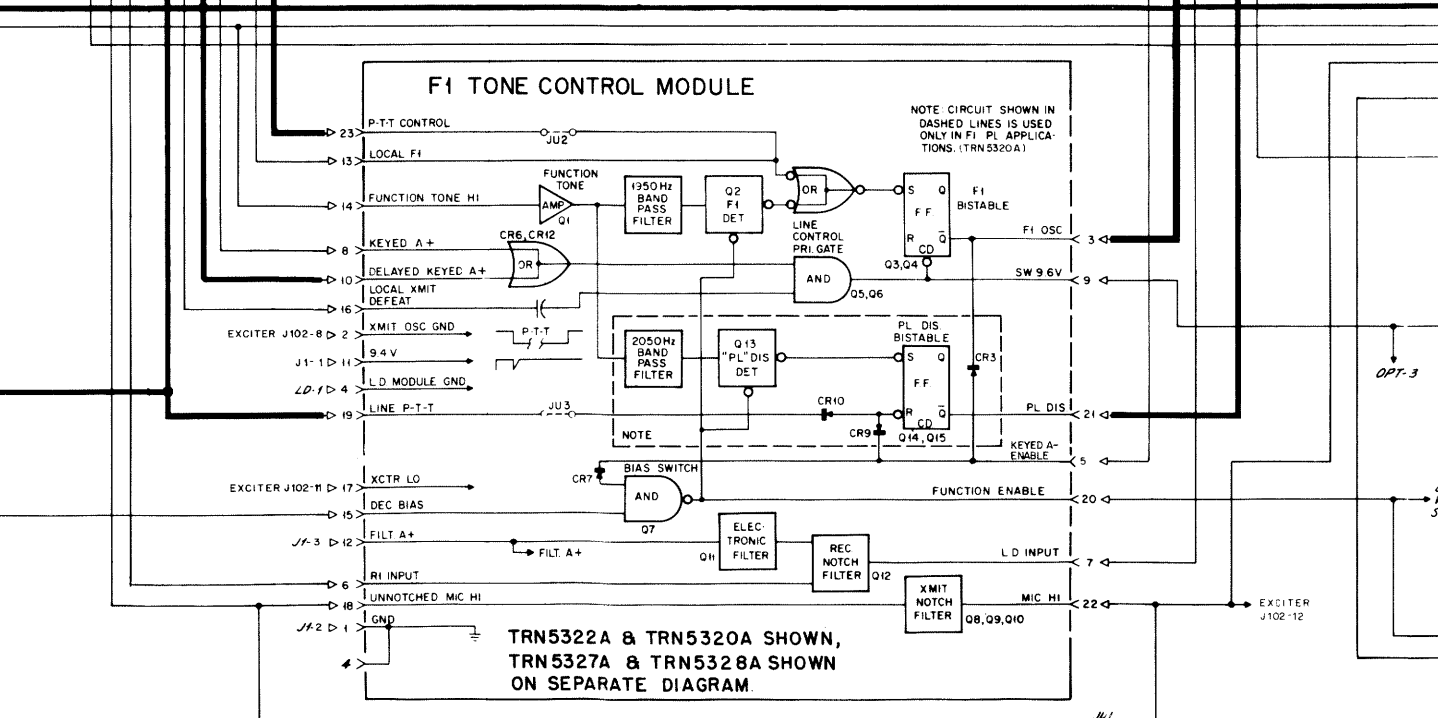
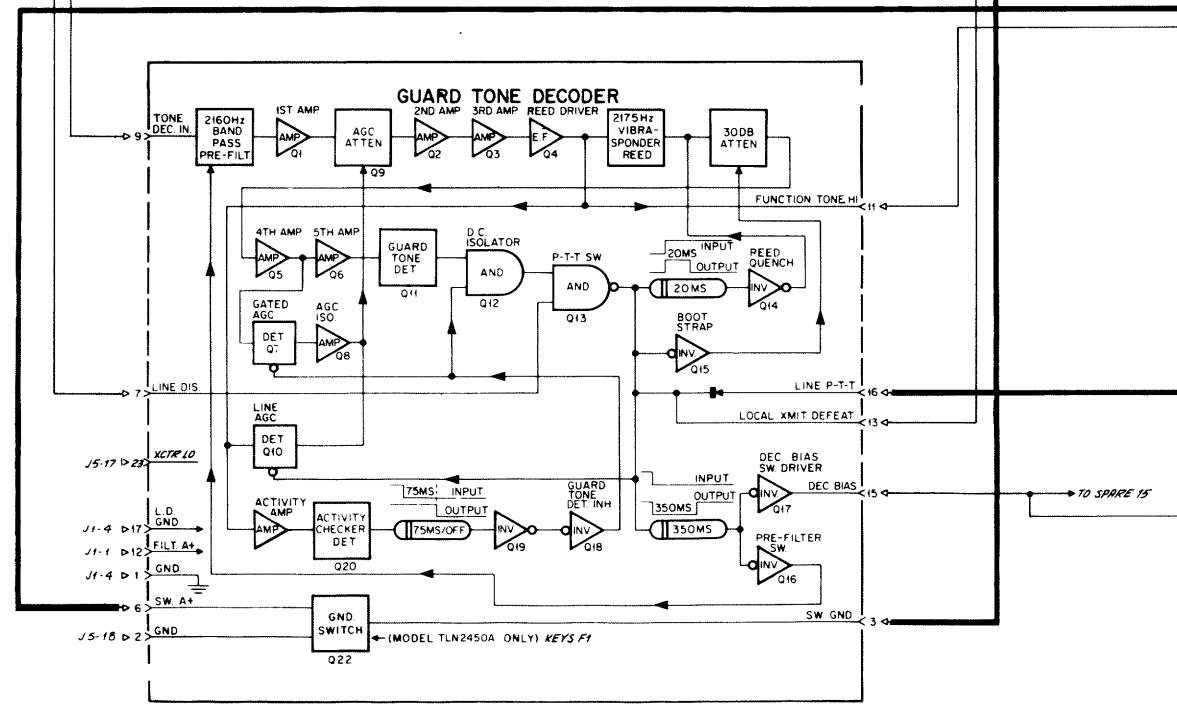
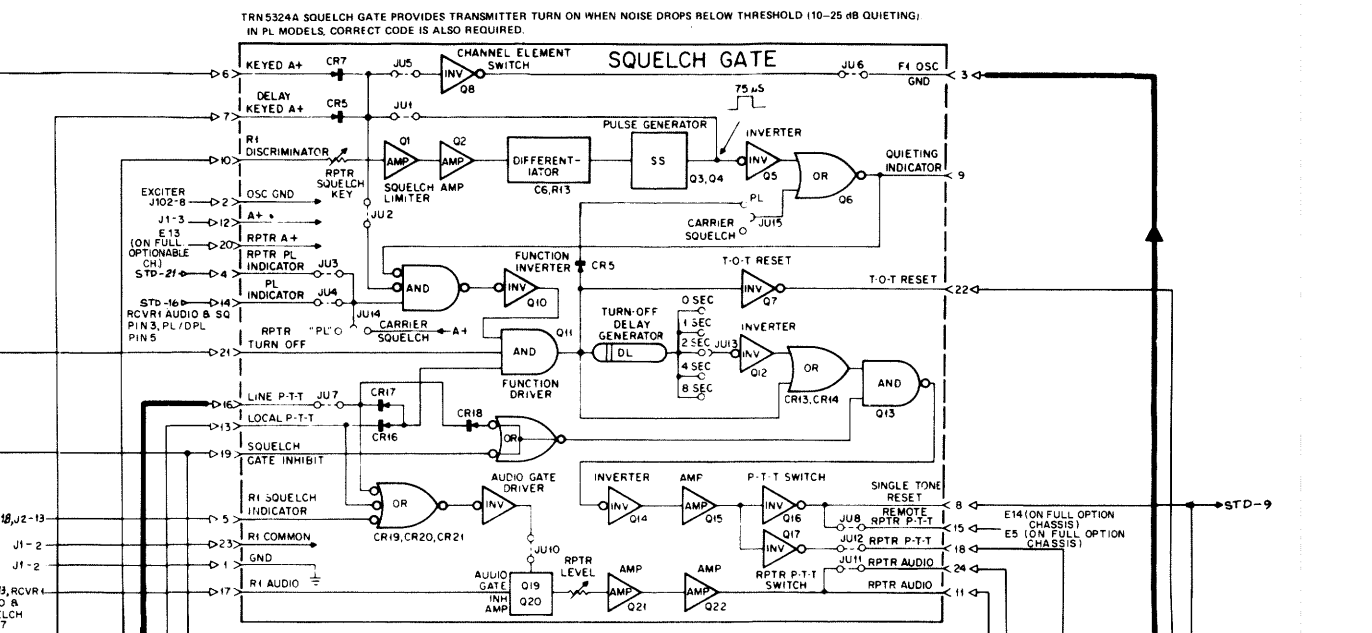
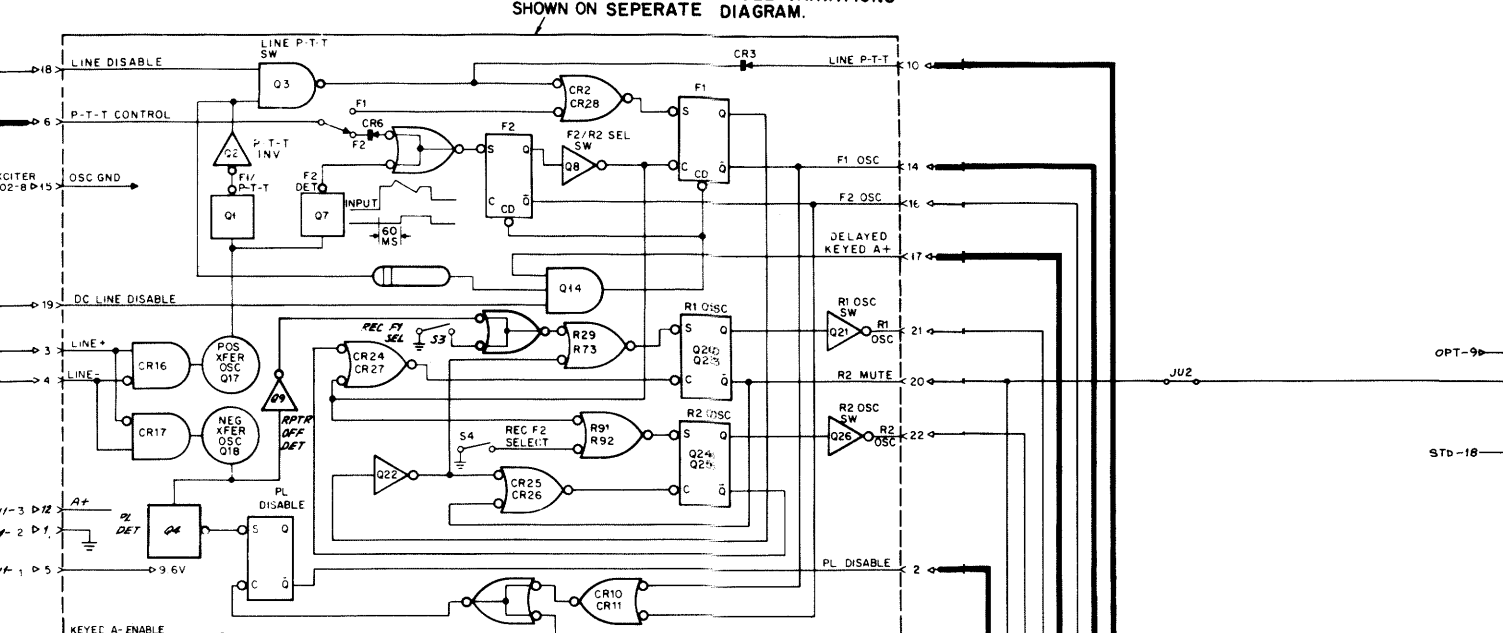
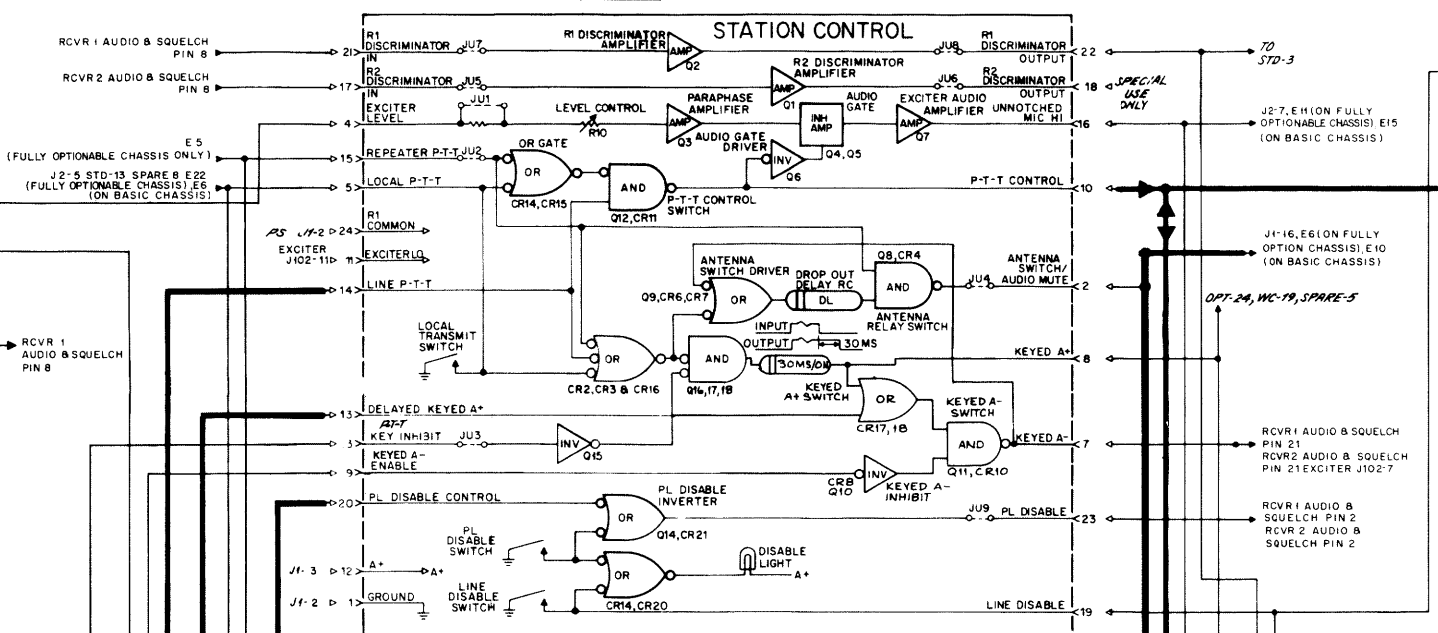
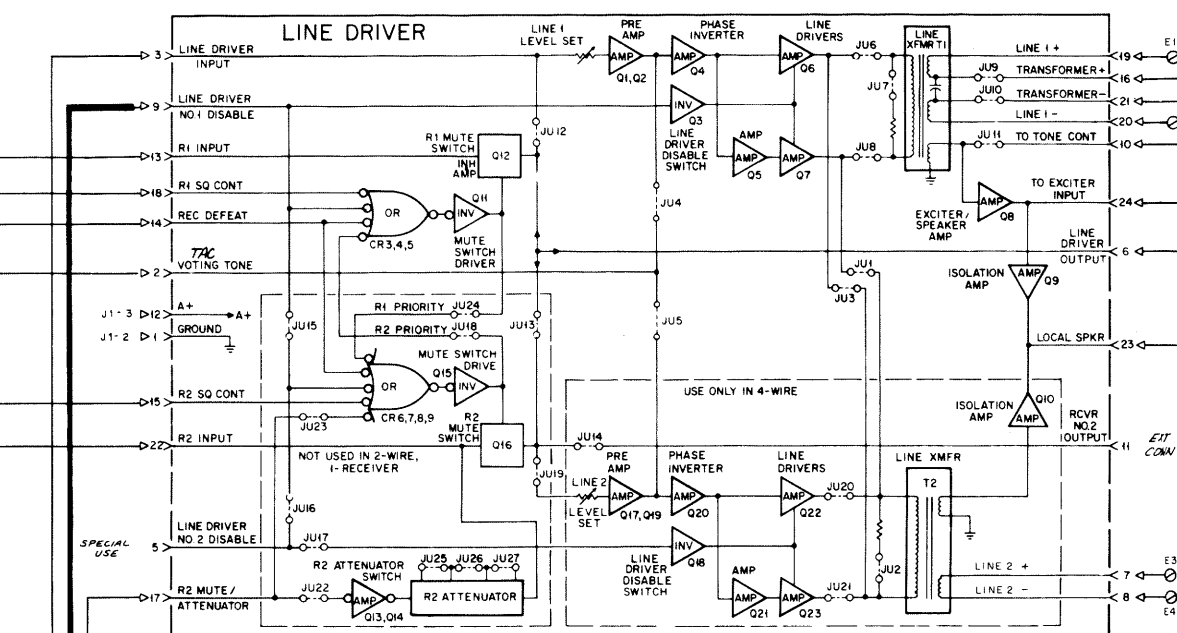

TLN2443A TONE REMOTE CONTROL BASE & REPEATER STATIONS OR
TLN2443B GUARD TONE RELAY CONTROL STATIONS ONLY
CONVERTS 2175 Hz TONE TO A LINE P-T-T
GENERATES A 375-Hz WINDOW OSC BIAS TO ENABLE FUNCTION TONE RECOGNITION

TRN 5232A (F1) OR TRN 5230A (F1 - PL) CONTROL CONVERTS 1950 Hz TO
F1 OSC TURN-ON; CONVERTS 2050 Hz TO PL DISABLE TO ENABLE
CHANNEL MONITORING NOTCH FILTERS REJECT 2175 Hz BY 40 dB
TRN 5232A (F2) OR TRN 5230A (F2 - PL) CONTROL PROVIDES NOTCH
FILTERS TO REJECT 2175 Hz AND PL DISABLE FUNCTION (TLN2394A)
FOR THE FOUR-FREQUENCY MODEL STATIONS

TRN 5252A F2 CONTROL, 1800 Hz KEYS XMTDR F2 OR
TLN2444A C2-R2 CONTROL, 1800 Hz KEYS XMTDR ON F2, 1750 Hz SELECTS REC F1 & MUTES REC F2,
1800 Hz SELECTS REC F2 AND MUTES REC F2, 1400 Hz J22 ENABLE SIMULTANEOUS XMTDR & REC (HARD SELECTION) OR
TRN 5252A F2-R2 MUTE CONTROL, 1800 Hz KEYS XMTDR ON F2, 1750 Hz MUTES R2, 1800 Hz UNMUTES R2 (AUI1 & J22 ENABLES XMT
ON F1), WITH R2 MUTE AND XMT ON F2 WITH R2 UNMUTED OR
TLN2449A PAGING CONTROL, 1800 Hz KEYS XMTDR WITHOUT PL MODULATION OR
POSITION WIRED TO ACCEPT SINGLE TONE DECODER (NOT SHOWN) WHICH CAN BE WIRELINE ACTIVATED

Functional Block Diagrams
Detailed 1 & 2 Frequency Stations
Motorola No. PEPS-34773-A
(Sheet 3 of 5)

FOUR FREQUENCY EXCITER AUDIO & TRANSMITTER KEYING

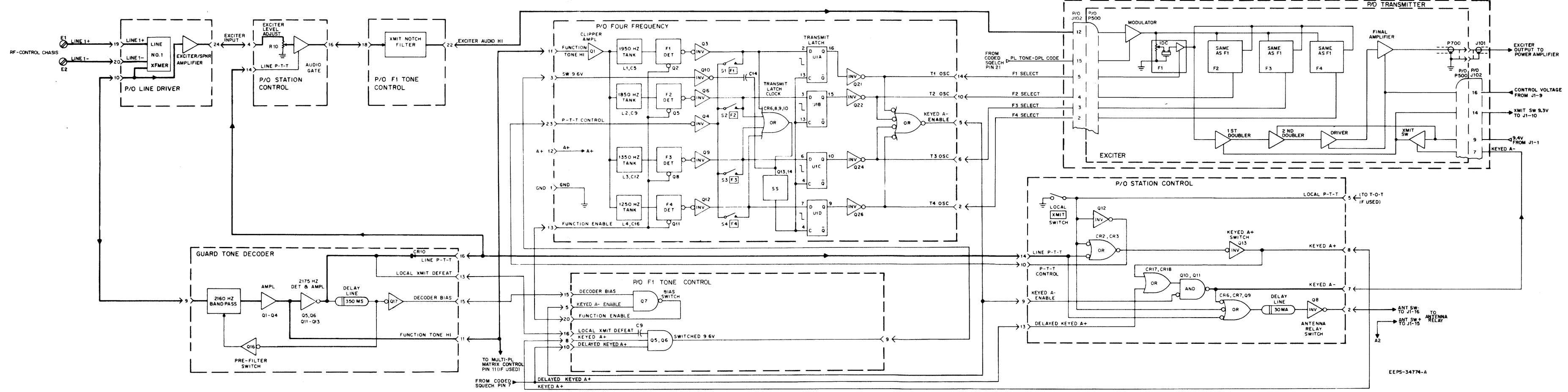

FOUR FREQUENCY RECEIVER AUDIO AND FREQUENCY SELECTION

