

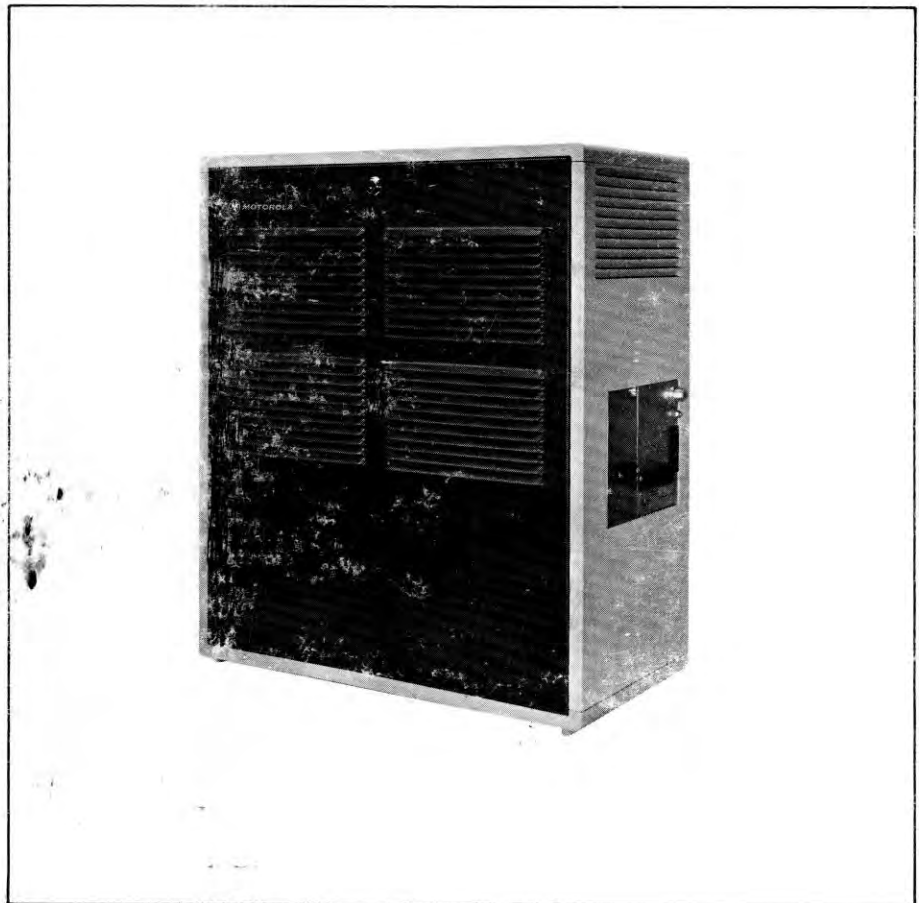

MSR 2000™

VHF Base and Repeater Stations

132-174 MHz



MUST BE USED WITH
Associated Control and Audio Instruction Manual
68P81061E40

68P81061E50-B

COMMERCIAL WARRANTY (STANDARD)

Motorola radio communications products are warranted to be free from defects in material and workmanship for a period of ONE (1) YEAR, (except for crystals and channel elements which are warranted for a period of ten (10) years) from the date of shipment. Parts, including crystals and channel elements, will be replaced free of charge for the full warranty period but the labor to replace defective parts will only be provided for One Hundred-Twenty (120) days from the date of shipment. Thereafter purchaser must pay for the labor involved in repairing the product or replacing the parts at the prevailing rates together with any transportation charges to or from the place where warranty service is provided. This express warranty is extended by Motorola Communications and Electronics, Inc., 1301 E. Algonquin Road, Schaumburg, Illinois 60196, to the original purchaser only, and only to those purchasing for purpose of leasing or solely for commercial, industrial, or governmental use.

THIS WARRANTY IS GIVEN IN LIEU OF ALL OTHER WARRANTIES EXPRESS OR IMPLIED WHICH ARE SPECIFICALLY EXCLUDED, INCLUDING WARRANTIES OF MERCHANTABILITY OR FITNESS FOR A PARTICULAR PURPOSE. IN NO EVENT SHALL MOTOROLA BE LIABLE FOR INCIDENTAL OR CONSEQUENTIAL DAMAGES TO THE FULL EXTENT SUCH MAY BE DISCLAIMED BY LAW.

In the event of a defect, malfunction or failure to conform to specifications established by seller, or if appropriate, to specifications accepted by Seller in writing, during the period shown, Motorola, at its option, will either repair or replace the product or refund the purchase price thereof, and such action on the part of Motorola shall be the full extent of Motorola's liability hereunder.

This warranty is void if:

- a. the product is used in other than its normal and customary manner;
- b. the product has been subject to misuse, accident, neglect or damage;
- c. unauthorized alterations or repairs have been made, or unapproved parts used in the equipment.

This warranty extends only to individual products, batteries are excluded, but carry their own separate limited warranty. Because each radio system is unique, Motorola disclaims liability for range, coverage, or operation of the system as a whole under this warranty except by a separate written agreement signed by an officer of Motorola.

Non-Motorola manufactured products are excluded from this warranty, but subject to the warranty provided by their manufacturers, a copy of which will be supplied to you on specific written request.

In order to obtain performance of this warranty, purchaser must contact its Motorola salesperson or Motorola at the address first above shown, attention Quality Assurance Department.

This warranty applies only within the United States.

EPS-27734-O

COMPUTER SOFTWARE COPYRIGHTS

The Motorola products described in this instruction manual may include copyrighted Motorola computer programs stored in semiconductor memories or other media. Laws in the United States and other countries preserve for Motorola certain exclusive rights for copyrighted computer programs, including the exclusive right to copy or reproduce in any form the copyrighted computer program. Accordingly, any copyrighted Motorola computer programs contained in the Motorola products described in this instruction manual may not be copied or reproduced in any manner without the express written permission of Motorola. Furthermore, the purchase of Motorola products shall not be deemed to grant either directly or by implication, estoppel, or otherwise, any license under the copyrights, patents or patent applications of Motorola, except for the normal non-exclusive, royalty free license to use that arises by operation of law in the sale of a product.

EPS-34440-B

68P811;2E94-B



CONTENTS

SECTION	NUMBER
Warranty	Inside Cover
Foreword	Pages vi, vii
Performance Specifications — Intermittent Duty	Page viii
Model Chart — Intermittent Duty	Page ix
Model Breakdown Chart — Intermittent Duty	Page x
Option Chart — Intermittent Duty	Pages xi, xii
Performance Specifications — Continuous Duty	Page xiii
Model Chart — Continuous Duty	Page xv
Model Breakdown Chart — Continuous Duty	Page xvi
Option Chart — Continuous Duty	Page xvii, xviii
General Safety Information	EPS-28750

DESCRIPTION

DESCRIPTION	68P81062E49
1. MANUAL USAGE	Page 1
2. INTRODUCTION	Page 1
3. STATION COMPONENT DESCRIPTION	Page 2
3.1 Transmitter	Page 2
3.2 Receiver	Page 2
3.3 Power Supply	Page 3
4. UNIQUE FEATURES	Page 3
5. OPTIONS	Page 4

INSTALLATION

LIGHTNING PROTECTION RECOMMENDATIONS	68P81111E17
INSTALLATION	68P81062E54
1. FCC REQUIREMENTS	Page 1
2. INSPECTION	Page 1
3. PLANNING THE INSTALLATION	Page 1
4. VENTILATION	Page 1
5. INSTALLATION OF 24-, 29-, 32-, AND 37-INCH INDOOR MSR 2000 CABINETS	Page 1
6. ANTENNA CONNECTIONS	Page 3
7. AC INPUT POWER AND GROUND CONNECTIONS	Page 3
7.1 Introduction	Page 3
7.2 Station Installation Using Power Line Cord Supplied with the Station	Page 4
7.3 Station Installation Using Conduit For Primary Power Connection	Page 4
8. OPTIONAL DC INPUT POWER CONNECTIONS	Page 4

Motorola, MSR 2000, Private-Line, and Digital Private-Line are trademarks of Motorola, Inc.

SECTION

NUMBER

9.	OPTIONAL MODE JUMPERING	Page 5
9.1	General	Page 5
9.2	Time-Out Timer Module	Page 5
9.3	Squelch Gate	Page 5
9.4	Two-Receiver Stations	Page 5
10.	CONTROL LINE CONNECTIONS	Page 5
10.1	Introduction	Page 5
10.2	Line Specifications	Page 5
10.3	Installation	Page 6
11.	CONTROL LINE LEVEL ADJUSTMENT	Page 6
11.1	General Information	Page 6
11.2	Adjustments	Page 7

MAINTENANCE

STATION MAINTENANCE	68P81062E53	
1.	INTRODUCTION	Page 1
2.	LOCAL OPERATION	Page 1
2.1	General	Page 1
2.2	Transmitter Control	Page 2
2.3	Local Microphone	Page 2
2.4	Local Speaker	Page 2
2.5	Handset	Page 2
2.6	Portable Test Set (For Stations Without Built-In Metering)	Page 2
2.7	Frequency Selection	Page 2
2.8	Selection of Other Modes	Page 2
2.9	Received Audio	Page 2
2.10	Transmitting	Page 2
2.11	Concluding Local Operation	Page 2
3.	MAINTENANCE TECHNIQUES	Page 3
3.1	General	Page 3
3.2	Transmitter and Receiver	Page 3
3.3	Power Supply	Page 3
3.4	Remote Control Unit	Page 3
4.	RECOMMENDED TEST EQUIPMENT	Page 4
5.	DISASSEMBLY AND SERVICE ACCESS	Page 5
5.1	Front Cover and Line Fuse	Page 5
5.2	Power Amplifier Access and Removal	Page 5
5.3	RF Control Chassis Access and Removal	Page 6
5.4	Exciter and Receiver Access and Removal	Page 6
5.5	Speaker Intercom With Speaker and DC Metering Chassis Access	Page 9
5.6	Duplexer Removal	Page 9
5.7	Power Supply Access	Page 9
5.8	Two-Receiver Coupler Removal	Page 9
5.9	Junction Box Access	Page 10
5.10	Wraparound Cover Removal	Page 10
6.	MECHANICAL PARTS IDENTIFICATION	Page 10
MSR 2000	Basic Model Station Mechanical Parts Identification	Page 11
MSR 2000	Fully Optionable Model Station Mechanical Parts Identification	Page 15
MSR 2000	Base Station Service Intercom With Speaker and DC Metering Chassis Mechanical Parts Identification	Page 19
MSR 2000	Base Station Power Amplifier Mechanical Parts Identification	Page 20
MSR 2000	Base Station Miscellaneous Parts Lists	Page 21
MSR 2000	Intermittent Duty Base Station RF Intercabling Diagram and Parts List	Page 23
MSR 2000	Intermittent Duty Base Station TKN8234A Main Wiring Harness Schematic Diagram and Parts List	Page 24
MSR 2000	Continuous Duty Base Station RF Intercabling Diagram and Parts Lists	Page 25

SECTION

NUMBER

MSR 2000 Continuous Duty Base Station TKN8319A Main Wiring Harness
 Schematic Diagram and Parts Lists Page 26
TKN8320A and TKN8321A Two-Wire and Four-Wire EIA Cable Kit;
and TKN8286A and TKN8287A Two-Wire and Four-Wire Line Cable Kit
 Schematic Diagram and Parts List Page 27

RECEIVER

RECEIVER 68P81061E99

1. DESCRIPTION Page 1
2. THEORY OF OPERATION Page 2
 - 2.1 PI Filter, RF Preselector, Optional Preamplifier Page 2
 - 2.2 Local Oscillator Injection Circuitry Page 2
 - 2.3 Mixer Page 2
 - 2.4 I-F Circuitry Page 2
 - 2.5 Limiter/Detector Page 3
 - 2.6 9.5 Volt Regulator Page 3
 - 2.7 Delayed Keyed A + Page 3
3. MAINTENANCE Page 3
4. RECEIVER FUNCTIONAL TESTS Page 3
 - 4.1 Audio and Squelch Test Page 3
 - 4.2 20 dB Quieting Test Page 3
 - 4.3 Receiver Gain Measurements Page 4
5. TROUBLESHOOTING TECHNIQUES Page 4
 - 5.1 Visual Inspection Page 4
 - 5.2 Alignment as a Troubleshooting Technique Page 4
 - 5.3 Troubleshooting Integrated Circuits Page 4
 - 5.4 Troubleshooting Crystals Page 4

Receiver Troubleshooting Chart CEPS-34364
 VHF Receiver Alignment PEPS-34505
 Receiver Maintenance PEPS-34544

TRANSMITTER

TRANSMITTER 68P81062E36

1. GENERAL Page 2
2. EXCITER Page 2
3. POWER AMPLIFIER Page 2
4. ALIGNMENT Page 2
 - Intermittent Duty Transmitter Alignment Page 3
 - Intermittent Duty Transmitter Functional Interconnect Diagram Page 4
 - Continuous Duty Transmitter Alignment Page 5
 - Continuous Duty Transmitter Functional Interconnect Diagram Page 6

EXCITER 68P81062E37

1. DESCRIPTION Page 1
2. THEORY OF OPERATION Page 1
 - 2.1 Transmit Audio Circuit Page 1
 - 2.2 Channel Elements Page 1
 - 2.3 Multipliers and Amplifiers Page 1
3. EXCITER FUNCTIONAL TESTS Page 2
 - 3.1 Exciter Power Output Test Page 2
 - 3.2 Frequency Test Page 2
 - 3.3 Deviation Test Page 2
4. TROUBLESHOOTING Page 2

TLD9231A and TLD9232A Simplex Exciter; and TLD9241A and TLD9242A Duplex Exciter
 Schematic Diagram, Circuit Board Detail and Parts List PEPS-34789

SECTION

NUMBER

POWER AMPLIFIER — INTERMITTENT DUTY	68P81062E38
1. GENERAL	Page 1
2. THEORY OF OPERATION	Page 1
2.1 Power Amplifier Board	Page 1
2.2 Power Control Circuitry	Page 1
3. POWER AMPLIFIER SERVICING	Page 2
3.1 General	Page 2
3.2 Power Amplifier Board Troubleshooting Procedure	Page 2
3.3 Power Amplifier Transistor Replacement	Page 3
3.4 Power Amplifier Board Removal	Page 4
3.5 Power Amplifier Functional Tests	Page 5
TLD2532A Power Amplifier Schematic Diagram, Circuit Board Details, and Parts Lists	PEPS-34790

POWER AMPLIFIER — CONTINUOUS DUTY	68P81063E01
1. GENERAL	Page 1
2. THEORY OF OPERATION	Page 1
2.1 Power Amplifier Board	Page 1
2.2 Power Control Board Functional Theory of Operation	Page 1
2.3 Power Control Board Detailed Theory of Operation	Page 3
3. MAINTENANCE	Page 5
3.1 Power Amplifier Board	Page 5
3.2 Power Control Board	Page 8
4. TROUBLESHOOTING PROCEDURES	Page 9
4.1 General	Page 9
4.2 Visual	Page 9
4.3 Voltage Checks	Page 9
4.4 Troubleshooting	Page 9
5. REPAIR PROCEDURES	Page 9
5.1 Resistance Measurements of Transistors in Push-Pull Pairs	Page 9
5.2 Transistor Removal Procedure	Page 9
5.3 Transistor Installation Procedure	Page 10
5.4 Procedures for Resistance Measurements of Transistors	Page 10
TRN5585A Exciter Control Voltage Regulator Schematic Diagram, Circuit Board Detail, and Parts Lists	PEPS-35247
TLD5960A Power Control Board Schematic Diagram, Circuit Board Detail and Parts Lists	PEPS-35251
TLD5950A Series Power Amplifier Board Schematic Diagram, Circuit Board Detail and Parts Lists	PEPS-35249

ANTENNA SWITCH	68P81062E33
-----------------------------	-------------

POWER SUPPLY

STANDARD POWER SUPPLY	68P81062E46
1. DESCRIPTION	Page 1
2. THEORY OF OPERATION	Page 2
2.1 TRN5336A Standard Power Supply	Page 2
2.2 TPN6138A Distribution Board	Page 2
2.3 TRN5119A Auxiliary Regulator Board	Page 2
3. REGULATED OUTPUT VOLTAGE ADJUSTMENT PROCEDURE	Page 4
4. MAINTENANCE	Page 4
4.1 Introduction	Page 4
4.2 Test Equipment Required	Page 4
4.3 Auxiliary Regulator Chassis Removal	Page 4
4.4 Power Supply Removal	Page 5
Troubleshooting Chart	Page 7
Parts Locations and Lists	PEPS-34739
Functional Block Diagram	EEPS-34687
TRN5336A Standard Power Supply and TPN6138A Distribution Board Schematic Diagram, Circuit Board Details, and Parts Lists	PEPS-34737
TRN5119A Auxiliary Regulator Board Schematic Diagram, Circuit Board Detail, and Parts List	PEPS-38130
TPN1191A Standard Power Supply Cable Interconnect Wiring Diagram	DEPS-34365

BATTERY CHARGER POWER SUPPLY, OPTION C28	68P81062E47
1. DESCRIPTION	Page 1
2. THEORY OF OPERATION	Page 2
2.1 TRN5336A Standard Power Supply	Page 2
2.2 TRN6137A Battery Charger Board	Page 3
2.3 TRN5119A Auxiliary Regulator Board	Page 3
2.4 TRN5120A Battery Revert Control Board	Page 5
3. BATTERY CONNECTION AND INSTALLATION	Page 6
3.1 Power Supply	Page 7
3.2 Battery Protection and Alarm	Page 7
4. LEVEL ADJUSTMENTS	Page 7
4.1 A + Voltage Adjustment	Page 7
4.2 Regulated Output Voltage Adjustment	Page 8
4.3 Alarm Tone Level Adjustment	Page 8
4.4 Low-Voltage Detector Adjustment	Page 8
5. MAINTENANCE	Page 8
5.1 Introduction	Page 8
5.2 Test Equipment Required	Page 8
5.3 Auxiliary Regulator Chassis Removal	Page 9
5.4 Power Supply Removal	Page 9
5.5 Battery Maintenance	Page 9
Troubleshooting Chart	Page 12
Parts Lists and Location	PEPS-34743
Functional Block Diagram	EEPS-34688
TRN5336A Power Supply and TRN6137A Battery Charger Board Schematic Diagram, Circuit Board Detail, and Parts Lists	PEPS-34740
TRN5119A Auxiliary Regulator Board Schematic Diagram, Circuit Board Detail, and Parts List ..	PEPS-34736
TRN5120A Battery Revert Control Board Schematic Diagram, Circuit Board Detail, and Parts List .	PEPS-34742
TPN1192A Battery Charger Power Supply Cable Interconnect Wiring Diagram	DEPS-34366

ACCESSORIES

DUPLEXER	68P81062E34
1. INTRODUCTION	Page 1
2. INSTALLATION	Page 2
3. THEORY OF OPERATION	Page 2
4. REMOVAL/REPLACEMENT OF COUPLING LOOPS	Page 2
4.1 Removal Procedure	Page 2
4.2 Replacement Procedure	Page 2
5. RECOMMENDED TUNING PROCEDURE	Page 5
5.1 Method 1	Page 5
5.2 Method 2	Page 5
5.3 Minor "Touch-Up" Procedures	Page 7
5.4 Tuning the Notch	Page 7
2-RECEIVER COUPLER	68P81063E03
1. ELECTRICAL DESCRIPTION	Page 1
2. PHYSICAL DESCRIPTION	Page 1
2-RECEIVER COUPLER	68P81062E32
1. ELECTRICAL DESCRIPTION	Page 1
2. PHYSICAL DESCRIPTION	Page 1
MSR 2000 BASE STATION SERVICE ACCESSORIES	68P81062E44
1. DESCRIPTION	Page 1
2. OPERATING INSTRUCTIONS	Page 2
2.1 Local Speaker	Page 2
2.2 Metering	Page 2
MSR 2000 BASE (RA) CONFIGURATION	68P81112E71
1. DESCRIPTION AND APPLICATION	Page 1
2. CONNECTIONS BETWEEN BASE (RA) AND REPEATER (RA) STATIONS	Page 2
Typical MSR 2000 Base (RA) To Repeater (RA) Station Interconnect Diagram	Page 3
DYNAMIC MICROPHONE	68P81062E39

FOREWORD

1. SCOPE OF MANUAL

This manual is intended for use by experienced technicians familiar with similar types of equipment. It contains all service information required for the equipment described and is current as of the printing date. Changes which occur after the printing date are incorporated by Instruction Manual Revisions (SMR). These SMR's are added to the manuals as the engineering changes are incorporated into the equipment.

2. MODEL AND KIT IDENTIFICATION

Motorola equipments are specifically identified by an overall model number on the nameplate. In most cases, assemblies and kits which make up the equipment also have kit model numbers stamped on them. When a production or engineering change is incorporated, the applicable schematic diagrams are updated.

3. SERVICE

Motorola's National Service Organization offers one of the finest nation-wide installation and

maintenance programs available to communication equipment users. This organization includes approximately 900 authorized Motorola Service Stations (MSS) located throughout the United States, each manned by one or more trained, FCC licensed technicians.

These MSS's are independently owned and operated and were selected by Motorola to service its customers. Motorola maintenance is available on either a time and material basis or on a periodic fixed-fee type arrangement.

The administrative staff of this organization consists of national, area and district service managers and district representatives, all of whom are Motorola employees with the objective to improve the service to our customers.

Should you wish to purchase a service contract for your Motorola equipment, contact your Motorola Service Representative, or write to:

National Service Manager
Motorola Communications and Electronics, Inc.
1303 E. Algonquin Road
Schaumburg, Illinois 60196

REPLACEMENT PARTS ORDERING

ORDERING INFORMATION

Motorola maintains a number of parts offices strategically-located throughout the United States. These facilities are staffed to process parts orders, identify part numbers, and otherwise assist in the maintenance and repair of Motorola Communications Sector products.

Orders for all parts *except* crystals, active filters, channel elements, and "Vibrasender"® and "Vibrasponder"® resonant reeds should be sent to the nearest area parts center. Orders for instruction manuals should also be sent to the area parts center.

When ordering replacement parts or equipment information, the complete identification number should be included. This applies to all components, kits, and chassis. If the component part number is not known, the order should include the number of the

chassis or kit of which it is a part, and sufficient description of the desired component to identify it.

Orders for crystals, channel elements, active filters, and reeds should be sent to the Component Product Sales & Service address listed below. Crystal and channel element orders should specify the crystal or channel element type number, crystal and carrier frequency, and the chassis model number in which the part is used.

Orders for active filters, *Vibrasender* and *Vibrasponder* resonant reeds should specify type number and frequency, should identify the owner/operator of the communications system in which these items are to be used; and should include any serial numbers stamped on the components being replaced.

COMPONENT PRODUCT SALES & SERVICE OFFICE

All Mail Orders
Motorola, Inc.
Component Product Sales & Service
P.O. Box 66191, O'Hare International Airport
Chicago, IL 60666

Correspondence
Motorola, Inc.
Component Product Sales & Service
2553 N. Edgington Street, Franklin Park, IL 60131
Tel: 312-451-1297, TWX: 910-227-0799, Telex: 433-0067

AREA PARTS OFFICES

Western Area Parts
1170 Chess Drive, Foster City, CA 94404
Tel: 415-349-8621, TWX: 910-375-3877

Pacific-Southwestern Area Parts
P.O. Box 85036, San Diego, CA 92138
Street Address:
9980 Carroll Canyon Road, San Diego, CA 92131
Tel (619-578-8030, TWX: 910-335-1516

Gulf States Area Parts
P.O. Box 73115, 1140 Cypress Station, Houston, TX 77090
Tel: 713-537-3636, TWX: 910-881-6392

Southwestern Area Parts
P.O. Box 34290, 3320 Belt Line Road, Dallas, TX 75234
Tel: 214-620-8511, TWX: 910-860-5505

Midwest Area Parts
1313 E. Algonquin Rd., Schaumburg, IL 60196
Tel: 312-576-7430, TWX: 910-693-0869

Southeastern Area Parts
P.O. Box 368, Decatur, GA 30031
Street Address:
5096 Panola Industrial Blvd., Decatur, GA 30032
Tel: 404-987-2232, TWX: 810-766-0876

Rocky Mountain Area Parts
20 Inverness Place East, Englewood, CO 80122
Tel: 303-790-2323, TWX: 910-935-0785

East Central Area Parts
12955 Snow Road, Parma, OH 44130
Tel (216-433-1560, TWX: 810-427-9424

Eastern Area Parts
85 Harristown Road, Glen Rock, NJ 07452
Tel: 201-447-4000, TWX: 710-988-5614

Mid-Atlantic Area Parts
7230 Parkway Drive, Hanover, MD 21076
Tel: 301-796-8763, TWX: 710-862-1941

National Accounts
Railroad, Airlines, and Telephone Sales
1313 E. Algonquin Rd., Schaumburg, IL 60196
Tel: 312-576-6512, TWX: 910-693-0869

All Canadian Orders
Motorola, Ltd., National Parts Department
3125 Steeles, Ave. E., Willowdale, Ontario M2H 2H6
Tel: 416-499-1441, TWX: 610-491-1032,
Telex: 06-526258

National Data Services

1171 West 17th Street, Tempe, AZ 85281
Tel: 602-994-6472, TWX: 910-951-1334

All Countries Except U.S. & Canada

Motorola, Inc., International Parts Department
1313 E. Algonquin Rd., Schaumburg, IL 60196. U.S.A.
Tel: 312-576-7241, TWX: 910-693-0869
Telex: 722443, Cable: MOTOL PARTS

68P81025E81-Y

INTERMITTENT DUTY STATION PERFORMANCE SPECIFICATIONS

GENERAL

Model	Frequency (MHz)	Minimum RF Output Power	Maximum PA Final Input Power	Input Voltage	A.C. Input Current (Amps)			
					Standard Supply		Battery Charging *** Supply	
C73GRB	146-174	110 W**	290 W	120 V AC +10% -20% 60 Hz Standard	Stby	Xmit	Stby	Xmit
C73GSB*					1	5.5	1	5.5
*Fully Optionable Models		**Variable Down To 60 W.		***Does Not Include Battery Charging Current				
No. of Frequencies		Single and two-frequency stations (dc and tone remote) Four-frequency stations (tone remote)						
Squelch Options		Carrier squelch, <i>Private-Line</i> coded squelch, and <i>Digital Private-Line</i> coded squelch						
Metering		Optional internal-mounted meter used to measure all essential circuits for tuning and checking.						

TRANSMITTER 146-174 MHz

RF Output Power	110/60 watts intermittent duty (cont. variable)
Output Impedance	50 ohms
Oscillator Frequency Stability	Channel element maintains oscillator frequency within $\pm .0005\%$ ($\pm .0002\%$ optional) from -30°C to $+60^{\circ}\text{C}$ ambient ($+25^{\circ}\text{C}$ reference)
Transmitter Sideband Noise	-90 dB @ ± 30 kHz -105 dB @ ± 1 MHz
Spurious & Harmonics	More than 85 dB below carrier
Modulation	15F2 and 16F3: ± 5 kHz for 100% at 1000 Hz.
Audio Sensitivity	Remote telephone line: -20 dBm max. for 60% max. dev. at 1000 Hz.
FM Noise	55 dB below 60% system dev. at 1000 Hz
Audio Response	+1, -3 dB from 6 dB/octave pre-emphasis, 300-3000 Hz, referenced to 1000 Hz
Audio Distortion	Less than 2% at 1000 Hz; 60% system dev.
FCC Designation	ABZ89FC3632 ($\pm .0005\%$ stability) ABZ89FC3132C ($\pm .0002\%$ stability) Licensable under parts 22, 74, 81, and 90 of FCC Rules.

RECEIVER 146-174 MHz

Channel Spacing	30 kHz/25 kHz		
EIA Modulation Acceptance	± 7 kHz minimum		
Oscillator Frequency Stability	Channel element maintains oscillator frequency within $\pm .0005\%$ ($\pm .0002\%$ optional) from -30°C to $+60^{\circ}\text{C}$ ambient ($+25^{\circ}\text{C}$ reference)		
Sensitivity 20 dB Quieting EIA SINAD	Without Preamp Less than 0.5 uV Less than 0.35 uV	With Preamp Less than 0.25 uV Less than 0.20 uV	
Intermodulation — EIA SINAD	-85 dB	-80 dB	
Selectivity — EIA SINAD	-100 dB (-95 dB with preamp)		
Spurious & Image Rejection	100 dB minimum	100 dB minimum	
Squelch Sensitivity Carrier Squelch Tone-Coded Squelch	0.2 uV or less at threshold 0.2 uV or less	0.10 uV or less at threshold 0.10 uV or less	
Audio Characteristics Remote Control Models	Telephone Line: Output: +11 dBm @ 600 ohms Response: +1, -3 dB Distortion: 3% @ 1000 Hz Hum & Noise: -55 dB For local service audio: Output Available: 1 W @ 8 ohms Response: +2, -8 dB Distortion: 5% @ 1000 Hz Hum & Noise: -55 dB		
FCC Receiver Certification Number	ABZ89FR3633		

Meets EIA Specifications per RS152B, RS204B, and RS220A.

SPECIFICATIONS SUBJECT TO CHANGE WITHOUT NOTICE.

**MODEL BREAKDOWN CHART
FOR
MSR 2000
INTERMITTENT DUTY
BASE/REPEATER (RT) STATIONS
146-174 MHz 110 W RF POWER OUTPUT**

CODE:
● = ONE ITEM SUPPLIED
2,4 = INDICATES QUANTITY SUPPLIED

ITEM	DESCRIPTION
TLN2502A	DUPLEXER
TLN2532A	110 WATT/60 WATT VARIABLE POWER PA DECK
TLN2442A	SINGLE-TONE DECODER MODULE
TLN2443A	GUARD TONE DECODER MODULE
TLN2444A	F2 TONE DECODER MODULE (C2-R2 CONTROL)
TLN2445A	SQUELCH CONTROL TONE DECODER MODULE
TLN2446A	REPEATER CONTROL TONE DECODER MODULE
TLN2447A	PRIVATE-LINE CONTROL TONE DECODER MODULE
TLN2448A	"WILD CARD" TONE DECODER CONTROL MODULE
TLN2449A	F2 TONE DECODER MODULE (PAGING CONTROL)
TLN2450A	GUARD TONE DECODER MODULE (GT RELAY CONTROL)
TLN2472B	BASIC CONTROL CHASSIS
TLN2473B	FULLY OPTIONAL CONTROL CHASSIS (1-RCV/R. BASE)
TLN2474B	FULLY OPTIONAL CONTROL CHASSIS (2-RCV/R. BASE)
TLN2475B	FULLY OPTIONAL CONTROL CHASSIS (REPEATER RT)
TPN1191A	STANDARD POWER SUPPLY
TPN1192A	BATTERY CHARGER POWER SUPPLY
TLN2515A	FULLY OPTIONAL CONTROL CHASSIS (4:BASE)

ITEM	DESCRIPTION
KLN6209A	VIBRASPONDER RESONANT REED
TFD6452A	HARMONIC FILTER
TKN6471A	CABLE
TKN8292A	CABLE
TKN8293A	CABLE
TLD8392A	FILTER CIRCUIT
TLD9252A	POWER AMPLIFIER BOARD
TLD9272A	POWER CONTROL BOARD
TPN1189A	AUXILIARY REGULATOR CHASSIS
INCLDS. TRN5119A	AUXILIARY REGULATOR BOARD
INCLDS. TRN5297A	HARDWARE KIT
INCLDS. TRN5299A	CHASSIS KIT
TPN1190A	AUXILIARY REGULATOR CHASSIS WITH BATTERY OPTION
INCLDS. TRN5119A	AUXILIARY REGULATOR BOARD
INCLDS. TRN5120A	BATTERY REVERT CONTROL BOARD
INCLDS. TRN5298A	HARDWARE
INCLDS. TRN5299A	CHASSIS
TPN6137A	BATTERY CHARGER BOARD
TPN6138A	DISTRIBUTION BOARD
TRN5081A,B	BACKPLANE INTERCONNECT BOARD (BASIC)
TRN5082A,B	BACKPLANE INTERCONNECT BOARD (1-RECEIVER)
TRN5083A,B	BACKPLANE INTERCONNECT BOARD (DUPLEX)
TRN5084A,B	BACKPLANE INTERCONNECT BOARD (2-RECEIVERS)
TRN5141A	PA HARDWARE
TRN5153A	BATTERY CHARGER HARDWARE
TRN5305A	TONE DECODER BOARD, SINGLE-TONE CONTROL
TRN5306A	SINGLE-TONE CONTROL PANEL
TRN5307A	TONE DECODER MODULE, GT
TRN5308A	TONE DECODER BOARD, C2-R2 CONTROL
TRN5309A	C2-R2 CONTROL PANEL
TRN5310A	TONE DECODER BOARD
TRN5311A	SQUELCH CONTROL PANEL
TRN5312A	REPEATER CONTROL PANEL
TRN5313A	PRIVATE-LINE CONTROL PANEL
TRN5315A	TONE DECODER BOARD, "WILD CARD" CONTROL
TRN5316A	"WILD CARD" CONTROL PANEL
TRN5317A	TONE DECODER BOARD, PAGING CONTROL
TRN5318A	PAGING CONTROL PANEL
TRN5319A	TONE DECODER MODULE, GT RELAY CONTROL
TRN5335A	INTERCONNECT HARDWARE
TRN5336A	500 WATT POWER SUPPLY HARDWARE
TRN5362A	INTERCONNECT HARDWARE
TRN5378A	CLOSING HARDWARE
TRN5432A	HARDWARE (BASIC)
TRN5433A	HARDWARE (1-RECEIVER)
TRN5434A	HARDWARE (2-RECEIVERS)
TRN5445A	HARDWARE, MTG (DUPLEXER)
TRN5462A,B	BACKPLANE INTERCONNECT BOARD
TRN5464A	TONE DECODER BOARD
TRN5465A	TONE DECODER BOARD
TKN8313A	CABLE INTERNAL PA

MSR 2000 INTERMITTENT DUTY STATIONS OPTION CHART

Option	Add	Delete	Description
C11AB	TRN5295A	—	Time-Out Timer
C12AG	HLD4052A	—	Receiver Preamplifier
C13AA	TLN2445A	—	Remote Squelch Control
C14AF	TLN2447A	—	Receive PL Tone On/Off
C15AA	TLN2448A	—	"Wild Card" Option
C28AN	TPN1192A TKN8295A TRN5155A	TPN1191A TRN5355A —	Battery Revert
C31DU	—	TRD6172A	Omit Receiver (146-174 MHz)
C50AC	—	—	Decreased RF Power Output for Maritime Operation (146-174 MHz)
C56AC	TRN5326A	—	Tone Mute Second Receiver (F2-R2)
C63AK	TRN5239A	TRN5240A	DC Transmit PL On/Off
C63AL	—	TLN2449A	Tone Transmit PL On/Off
C71AB	—	TMN6054A	Omit Microphone
C75AB	—	TRN5295A	Omit Time-Out Timer
C83AC	—	TLN2443A TRN5322A TRN5236A TKN8286A	Omit Wire Line Control (Carrier Squelch, Tone Stations)
C84AC	—	TLN2443A TRN5320A TRN5236A TKN8286A	Omit Wire Line Control (PL/DPL, Tone Stations)
C85AB	—	TRN5254A TRN5236A TKN8286A	Omit Wire Line Control (Carrier Squelch, DC Stations)
C86AC	—	TRN5240A TRN5236A TKN8286A	Omit Wire Line Control (PL/DPL, DC Stations)
C92AA	TRN5424A TBN6386A TRN5426A	TRN5423A TBN6385A TRN5425A	29" Cabinet
C113AA	TMN6054A	—	Dynamic Microphone
C116BP	TRD6182A TRN5431A TRN5443A	TRN6172A TRN5430A —	Shield Kit (One Receiver)
C116BQ	TRN5431A TRN5443A TRD6182A	TRN5429A TRD6172A —	Shield Kit (Basic)
C140AD	—	—	"AND" Squelch
C143AD	TRN5257A	TRN5254A	Repeater Control (Carrier Squelch, DC Stations)
C143AE	TRN5257A	TRN5240A	Repeater Control (PL/DPL, DC Stations)
C143AF	TLN2446A	—	Repeater Control (Tone Stations)
C144AH	TRN5235A TKN8287A	TRN5236A TKN8286A	4-Wire Line Audio (One Receiver)
C144AJ	TRN5235A TKN8287A	TRN5237A TKN8286A	4-Wire Line Audio (Two Receivers)
C149CV	TRN5069A TMN6054A TRN5080A	TRN5068A	Intercom, Metering and Microphone
C150AH	TRN5324A TKN8281A	TRN5254A	RA Base (Carrier Squelch, DC Stations)
C150AJ	TRN5324A TKN8281A	TRN5240A	RA Base (PL/DPL, DC Stations)
C150AK	TRN5324A TKN8281A	—	RA Base (Tone Station)
C158AB	TRN5292A TRN5330A (4)KLN6210A	— — KLN6209A	Multi PL Encoder

MSR 2000 INTERMITTENT DUTY STATIONS OPTION CHART (Cont'd.)

Option	Add	Delete	Description
C182AH	TRN5424A TBN6386A TRN5426A TKN8290A TLD2502A TRN5352A	TRN5423A TBN6385A TRN5425A TKN8289A — —	Add Duplexer (148-174 MHz)
C226AH	TRN5069A TRN5079A	TRN5068A —	Intercom Only
C257AD	TPN1222A TRN9109A TRN9114A	TPN1191A TRN5442A TRN5350A	Multi-Voltage, 50 Hz, Basic
C257AE	TPN1222A TRN9109A TRN9113A	TPN1191A TRN5442A TRN5351A	Multi-Voltage, 50 Hz, Fully Optionable
C261AC	(4)TLN8381A TRN5329A	KLN6209A —	Multi PL Decoder
C262AE	TRN5292A TRN5329A (4)KLN6210A (4)TLN8381A	(2)KLN6209A — — —	Multi-PL Repeater
C263AB	TRN5329A TRN5292A TRN5330A (4)KLN6210A (4)TLN8381A	KLN6209A — — — —	Multi PL Encoder/Decoder
C266AA	—	KLN6210A	Omit One <i>Vibrasender</i> Reed
C267AA	—	TLN8381A	Omit One <i>Vibrasponder</i> Reed
C269AP	TRN5293A TRN5294A TKN8287A	TRN5236A TKN8286A —	<i>Spectra TAC</i> Operation (Base)
C269AQ	TRN5293A TRN5294A TKN8287A TRN5331A	TLN5236A TKN8286A TRN5324A —	<i>Spectra TAC</i> Operation (Rptr)
C276AA	TRN5075A KLN6209A	TRN5074A —	Simplex PL TA-RB
C276AB	TRN5078A TRN6005A	TRN5077A —	Simplex DPL TA-RB
C323AA	—	TRN5427A	Omit Power Cord
C501AJ	—	KXN1088A	Omit One Transmit Element
C502AH	—	(2)KXN1088A	Omit Two Transmit Elements
C503AE	—	(3)KXN1088A	Omit Three Transmit Elements
C504AE	—	(4)KXN1088A	Omit Four Transmit Elements
C521AR	—	KXN1086B	Omit One Receive Element
C522AM	—	(2)KXN1086B	Omit Two Receive Elements
C523AH	—	(3)KXN1086B	Omit Three Receive Elements
C524AJ	—	(4)KXN1086B	Omit Four Receive Elements
C576AA	—	TLN2442A	Single-Tone Decoder
C601AC	KXN1095A	KXN1088A	One 2PPM Transmit Element
C602AB	(2)KXN1095A	(2)KXN1088A	Two 2PPM Transmit Elements
C603AB	(3)KXN1095A	(3)KXN1088A	Three 2PPM Transmit Elements
C604AC	(4)KXN1095A	(4)KXN1088A	Four 2PPM Transmit Elements
C621AC	KXN1112AA	KXN1086B	One 2PPM Receive Element
C622AB	(2)KXN1112AA	(2)KXN1086B	Two 2PPM Receive Elements
C623AB	(3)KXN1112AA	(3)KXN1086B	Three 2PPM Receive Elements
C624AB	(4)KXN1112AA	(4)KXN1086B	Four 2PPM Receive Elements
C681AB	TPN1223A TRN9114A TRN9110A	TPN1191A TRN5350A TRN5442A	Multi-Voltage, 60 Hz, Base
C681AC	TPN1223A TRN9110A TRN9113A	TPN1191A TRN5442A TRN5351A	Multi-Voltage, 60 Hz, Fully Optionable
C691AA	TRN5972A	TRN5427A	European Power Cord
C692AA	TRN5971A	TRN5427A	United Kingdom Power Cord

CONTINUOUS DUTY STATION PERFORMANCE SPECIFICATIONS

GENERAL

Model	Frequency (MHz)	Minimum RF Output Power	Maximum PA Final Input Power	Input Voltage	A.C. Input Current (Amps)			
					Standard Supply		Battery Charging *** Supply	
C73KRB	132-174	100 W**	200 W	120 V AC + 10% - 20% 60 Hz Standard	Stby	Xmit	Stby	Xmit
C73KSB*					1	4.6	1	4.6
*Fully Optionable Models		**Variable Down To 50 W.		***Does Not Include Battery Charging Current				
No. of Frequencies		Single and two-frequency stations (dc and tone remote) Four-frequency stations (tone remote)						
Squelch Options		Carrier squelch, <i>Private-Line</i> coded squelch, and <i>Digital Private-Line</i> coded squelch						
Metering		Optional internal-mounted meter used to measure all essential circuits for tuning and checking.						

TRANSMITTER 132-174 MHz

RF Output Power	100/50 watts continuous duty (cont. variable)
Output Impedance	50 ohms
Oscillator Frequency Stability	Channel element maintains oscillator frequency within $\pm .0005\%$ ($\pm .0002\%$ optional) from -30°C to $+60^{\circ}\text{C}$ ambient ($+25^{\circ}\text{C}$ reference)
Transmitter Sideband Noise	- 90 dB @ ± 30 kHz - 105 dB @ ± 1 MHz
Spurious & Harmonics	More than 85 dB below carrier
Modulation	15F2 and 16F3: ± 5 kHz for 100% at 1000 Hz.
Audio Sensitivity	Remote telephone line: - 20 dBm max. for 60% max. dev. at 1000 Hz.
FM Noise	55 dB below 60% system dev. at 1000 Hz
Audio Response	+ 1, - 3 dB from 6 dB/octave pre-emphasis, 300-3000 Hz, referenced to 1000 Hz
Audio Distortion	Less than 2% at 1000 Hz; 60% system dev.
FCC Designation	ABZ89FC3640 ($\pm .0005\%$ stability) ABZ89FC3641 ($\pm .0002\%$ stability) Licensable under parts 22, 74, 81, and 90 of FCC Rules.

RECEIVER 132-174 MHz

Channel Spacing	30 kHz/25 kHz	
EIA Modulation Acceptance	± 7 kHz minimum	
Oscillator Frequency Stability	Channel element maintains oscillator frequency within $\pm .0005\%$ ($\pm .0002\%$ optional) from -30°C to $+60^{\circ}\text{C}$ ambient ($+25^{\circ}\text{C}$ reference)	
Sensitivity	Without Preamp Less than 0.5 uV Less than 0.35 uV	With Preamp Less than 0.25 uV Less than 0.20 uV
20 dB Quieting EIA SINAD		
Intermodulation — EIA SINAD	- 85 dB	- 80 dB
Selectivity — EIA SINAD	- 100 dB (- 95 dB with preamp)	
Spurious & Image Rejection	100 dB minimum	100 dB minimum
Squelch Sensitivity		
Carrier Squelch	0.2 uV or less at threshold	0.10 uV or less at threshold
Tone-Coded Squelch	0.2 uV or less	0.10 uV or less
Audio Characteristics	Telephone Line:	
Remote Control Models	Output: + 11 dBm @ 600 ohms Response: + 1, - 3 dB Distortion: 3% @ 1000 Hz Hum & Noise: - 55 dB	
	For local service audio:	
	Output Available: 1 W @ 8 ohms Response: + 2, - 8 dB Distortion: 5% @ 1000 Hz Hum & Noise: - 55 dB	
FCC Receiver Certification Number	ABZ89FR3633	

Meets EIA Specifications per RS152B, RS204B, and RS220A.

SPECIFICATIONS SUBJECT TO CHANGE WITHOUT NOTICE.

**KRB "A" SUFFIX MODELS [BASIC]
KSB "A" SUFFIX MODELS [FULLY OPTIONALABLE]
MODEL CHART
FOR
MSR 2000
CONTINUOUS DUTY
BASE/REPEATER (RT) STATIONS
132-174 MHz 100 W RF POWER OUTPUT**

CODE:
 ● = ONE ITEM SUPPLIED
 2 = INDICATES QUANTITY SUPPLIED
 / = USED IN PLACE OF ONE 10.7 MHz I-F RECEIVER ON TWO RECEIVER STATIONS WITH CERTAIN FREQUENCY COMBINATIONS
 ★ = INDICATES A MODEL SERIES, SPECIFIC MODEL DEPENDS ON CARRIER FREQUENCY.

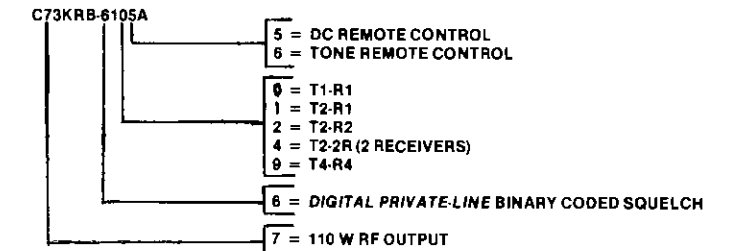

MODEL	DESCRIPTION											STATION MODEL	TYPE OF SQUELCH	T1 = ONE XMIT FREQ. T2 = TWO XMIT FREQS. R1 = ONE RCVR. FREQ. R2 = TWO RCVR. FREQS. 2R = TWO RCVR. — ONE FREQ. EACH	CONTROL TYPE
KLN6209A	VIBRASPONDER RESONANT REED											C73KRB-1105A	CARRIER	T1-R1	DC
KXN1086B	RECEIVE ELEMENT (10.7 MHz I-F) 5 PPM											C73KRB-1106A	CARRIER	T1-R1	DC
KXN1086BA	RECEIVE ELEMENT (10.7 MHz I-F) 5 PPM											C73KRB-1115A	CARRIER	T2-R1	DC
KXN1088A	TRANSMIT ELEMENT 5 PPM											C73KRB-1116A	CARRIER	T2-R1	DC
TKN8319A	STATION INTERCONNECT CABLE											C73KRB-1125A	CARRIER	T2-R2	DC
TKN8319A	STATION INTERCONNECT CABLE											C73KRB-1126A	CARRIER	T2-R2	DC
TKN8322A	TWO-WIRE LINE CABLE											C73KRB-3105A	PL	T1-R1	DC
TKN8322A	TWO-WIRE LINE CABLE											C73KRB-3106A	PL	T1-R1	DC
TKN8323A	PA POWER EXCITER CABLE											C73KRB-3115A	PL	T2-R1	DC
TKN8323A	PA POWER EXCITER CABLE											C73KRB-3116A	PL	T2-R1	DC
TKN8323A	NON-DUPLEXER CABLES											C73KRB-3125A	PL	T2-R2	DC
TKN8323A	NON-DUPLEXER CABLES											C73KRB-3126A	PL	T2-R2	DC
TLD9230A	100 W CONTINUOUS DUTY PA											C73KRB-6105A	DPL	T1-R1	DC
TLD9230A	100 W CONTINUOUS DUTY PA											C73KRB-6106A	DPL	T1-R1	DC
TLD9240A	SIMPLEX EXCITER											C73KRB-6115A	DPL	T2-R1	DC
TLD9240A	SIMPLEX EXCITER											C73KRB-6116A	DPL	T2-R1	DC
TLN2443A	GUARD TONE DECODER MODULE											C73KRB-6125A	DPL	T2-R2	DC
TLN2444A	C2-R2 TONE DECODER MODULE											C73KRB-6126A	DPL	T2-R2	DC
TLN2472B	BASIC CHASSIS											C73KRB-1105A	CARRIER	T1-R1	DC
TLN2473B	FULLY OPTIONALABLE CHASSIS (1 REC)											C73KRB-1106A	CARRIER	T1-R1	DC
TLN2474B	FULLY OPTIONALABLE CHASSIS (2 REC)											C73KRB-1115A	CARRIER	T2-R1	DC
TLN2475B	FULLY OPTIONALABLE CHASSIS (REPEATER RT)											C73KRB-1116A	CARRIER	T2-R1	DC
TRN1191A	120 V 60 Hz POWER SUPPLY											C73KRB-1125A	CARRIER	T2-R2	DC
TRD6170A	RECEIVER 10.7 MHz NON-FILTERED											C73KRB-1126A	CARRIER	T2-R2	DC
TRD6180A	RECEIVER 10.8 MHz FILTERED											C73KRB-3105A	PL	T1-R1	DC
TRD6270A	2 RECEIVER COUPLER											C73KRB-3106A	PL	T1-R1	DC
TRN5068A	R1 AUDIO BOARD											C73KRB-3115A	PL	T2-R1	DC
TRN5070A	R2 AUDIO BOARD											C73KRB-3116A	PL	T2-R1	DC
TRN5071A	R2 AUDIO PL BOARD											C73KRB-3125A	PL	T2-R2	DC
TRN5072A	R2 AUDIO DPL BOARD											C73KRB-3126A	PL	T2-R2	DC
TRN5073A	DUPLEX PL BOARD											C73KRB-6105A	DPL	T1-R1	DC
TRN5074A	SIMPLEX PL TA-RA BOARD											C73KRB-6106A	DPL	T1-R1	DC
TRN5076A	DUPLEX DPL BOARD											C73KRB-6115A	DPL	T2-R1	DC
TRN5077A	SIMPLEX DPL TA-RA BOARD											C73KRB-6116A	DPL	T2-R1	DC
TRN5078A	ANTENNA RELAY											C73KRB-6125A	DPL	T2-R2	DC
TRN5236A	1 RECEIVER, 2-WIRE AUDIO; LINE DRIVER MODULE											C73KRB-6126A	DPL	T2-R2	DC
TRN5237A	2 RECEIVER, 2-WIRE AUDIO; LINE DRIVER MODULE											C73KRB-1105A	CARRIER	T1-R1	DC
TRN5240A	F1 PL CONTROL MODULE											C73KRB-1106A	CARRIER	T1-R1	DC
TRN5245A	F1 CARRIER SQUELCH CONTROL MODULE											C73KRB-1115A	CARRIER	T2-R1	DC
TRN5255A	F2 R2 MUTE CONTROL MODULE											C73KRB-1116A	CARRIER	T2-R1	DC
TRN5256A	F2 R2 MUTE CONTROL MODULE											C73KRB-1125A	CARRIER	T2-R2	DC
TRN5258A	CMOS TIME OUT TIMER											C73KRB-1126A	CARRIER	T2-R2	DC
TRN5296A	4-FREQUENCY CONTROL MODULE											C73KRB-3105A	PL	T1-R1	DC
TRN5320A	F1 PL TONE DECODER MODULE											C73KRB-3106A	PL	T1-R1	DC
TRN5321A	STATION CONTROL MODULE											C73KRB-3115A	PL	T2-R1	DC
TRN5322A	F1 TONE DECODER MODULE											C73KRB-3116A	PL	T2-R1	DC
TRN5324A	SQUELCH GATE MODULE											C73KRB-3125A	PL	T2-R2	DC
TRN5325A	F2 TONE DECODER MODULE											C73KRB-3126A	PL	T2-R2	DC
TRN5327A	4F F1 TONE DECODER MODULE											C73KRB-6105A	DPL	T1-R1	DC
TRN5328A	4F F1 PL TONE DECODER MODULE											C73KRB-6106A	DPL	T1-R1	DC
TRN5350A	SIMPLEX JUNCTION BOX											C73KRB-6115A	DPL	T2-R1	DC
TRN5351A	DUPLEX JUNCTION BOX											C73KRB-6116A	DPL	T2-R1	DC
TRN5352A	RF PLASTIC PLUG											C73KRB-6125A	DPL	T2-R2	DC
TRN5353A	D-TYPE CONNECTOR PLASTIC PLUG											C73KRB-6126A	DPL	T2-R2	DC
TRN5355A	BATTERY PLASTIC PLUG											C73KRB-1105A	CARRIER	T1-R1	DC
TRN5567A	32" CABINET HARDWARE											C73KRB-1106A	CARRIER	T1-R1	DC
TRN5569A	32" CABINET HARDWARE											C73KRB-1115A	CARRIER	T2-R1	DC
TRN5427A	110 V POWER CORD											C73KRB-1116A	CARRIER	T2-R1	DC
TRN5575A	PS COVER											C73KRB-1125A	CARRIER	T2-R2	DC
TRN5429A	BASIC COVERS											C73KRB-1126A	CARRIER	T2-R2	DC
TRN5430A	OPTIONAL COVERS											C73KRB-3105A	PL	T1-R1	DC
TRN5431A	REPEATER COVERS											C73KRB-3106A	PL	T1-R1	DC
TRN5433A	DUPLEX RF COVER											C73KRB-3115A	PL	T2-R1	DC
TRN8005A	DPL CODE PLUG											C73KRB-3116A	PL	T2-R1	DC

**MODEL BREAKDOWN CHART
FOR
MSR 2000
CONTINUOUS DUTY
BASE/REPEATER (RT) STATIONS
132-174 MHz 100 WATT POWER OUTPUT**

CODE:

● = ONE ITEM SUPPLIED
2, 4 = INDICATES QUANTITY SUPPLIED

ITEM	DESCRIPTION
KLN8209A	VIBRASPONDER RESONANT FEED
TFD6101A	HARMONIC FILTER, 132-150.8 MHz
TFD6102A	HARMONIC FILTER, 150.8-174 MHz
TKN6471A	CABLE
TKN8292A	CABLE
TKN8293A	CABLE
TLD5952A	POWER AMPLIFIER BOARD, 132-150.8 MHz
TLD5953A	POWER AMPLIFIER BOARD, 150.8-162 MHz
TLD5954A	POWER AMPLIFIER BOARD, 162-174 MHz
TLD5960A	POWER CONTROL BOARD
TLD8392A	FILTER CIRCUIT
TLN2424A	POWER AMPLIFIER INPUT BRACKET ASSEMBLY
INCLDS	TRN5566A PA INPUT BRACKET
INCLDS	TRN5585A EXCITER CONTROL VOLTAGE REGULATOR
INCLDS	TKN8396A PA CABLE KIT
TPN1189A	AUXILIARY REGULATOR CHASSIS
INCLDS	TRN5119A AUXILIARY REGULATOR BOARD
INCLDS	TRN5297A HARDWARE KIT
INCLDS	TRN5298A CHASSIS KIT
TPN1190A	AUXILIARY REGULATOR CHASSIS WITH BATTERY OPTION
INCLDS	TRN5119A AUXILIARY REGULATOR BOARD
INCLDS	TRN5120A BATTERY REVERT CONTROL BOARD
INCLDS	TRN5298A HARDWARE
INCLDS	TRN5299A CHASSIS
TPN6137A	BATTERY CHARGER BOARD
TPN6138A	DISTRIBUTION BOARD
TRN5081A,B	BACKPLANE INTERCONNECT BOARD (BASIC)
TRN5082A,B	BACKPLANE INTERCONNECT BOARD (1-RECEIVER)
TRN5083A,B	BACKPLANE INTERCONNECT BOARD (DUPLX)
TRN5084A,B	BACKPLANE INTERCONNECT BOARD (2-RECEIVERS)
TRN5153A	BATTERY CHARGER HARDWARE
TRN5305A	ONE TONE DECODER BOARD, SINGLE-TONE CONTROL
TRN5306A	SINGLE-TONE CONTROL PANEL
TRN5307A	ONE TONE DECODER MODULE, GUARD TONE
TRN5308A	ONE TONE DECODER BOARD, C2-R2 CONTROL
TRN5309A	C2-R2 CONTROL PANEL
TRN5310A	ONE TONE DECODER BOARD
TRN5311A	SQUELCH CONTROL PANEL
TRN5312A	REPEATER CONTROL PANEL
TRN5313A	PRIVATE-LINE CONTROL PANEL
TRN5315A	ONE TONE DECODER BOARD "WILD CARD" CONTROL
TRN5316A	"WILD CARD" CONTROL PANEL
TRN5317A	ONE TONE DECODER BOARD, PAGING CONTROL
TRN5318A	PAGING CONTROL PANEL
TRN5319A	ONE TONE DECODER MODULE, GUARD TONE RELAY CONTROL
TRN5335A	INTERCONNECT HARDWARE
TRN5336A	500 WATT POWER SUPPLY HARDWARE
TRN5362A	INTERCONNECT HARDWARE
TRN5432A	HARDWARE, BASIC
TRN5433A	HARDWARE (1-RECEIVER)
TRN5434A	HARDWARE (2-RECEIVERS)
TRN5435A	HARDWARE (DUPLX)
TRN5445A	HARDWARE (DUPLXER MOUNTING)
TRN5462A,B	BACKPLANE INTERCONNECT BOARD
TRN5464A	ONE TONE DECODER BOARD
TRN5465A	ONE TONE DECODER BOARD
TRN5577A	PA CASTING & HARDWARE
TRN5586A	PA HARDWARE
TRN8069A	SUPPRESSION NETWORK

ITEM	DESCRIPTION
TLD2502A	DUPLEXER
TLD2601A	100 WATT/50 WATT VARIABLE PA DECK, 132-150.8 MHz
TLD2602A	100 WATT/50 WATT VARIABLE PA DECK, 150.8-162 MHz
TLD2603A	100 WATT/50 WATT VARIABLE PA DECK, 162-174 MHz
TLN2442A	SINGLE TONE DECODER MODULE
TLN2443A	GUARD TONE DECODER MODULE
TLN2444A	F2 TONE DECODER MODULE (C2-R2 CONTROL)
TLN2445A	SQUELCH CONTROL TONE DECODER MODULE
TLN2446A	REPEATER CONTROL TONE DECODER MODULE
TLN2447A	PRIVATE-LINE CONTROL TONE DECODER MODULE
TLN2448A	"WILD CARD" TONE DECODER CONTROL MODULE
TLN2449A	F2 TONE DECODER MODULE (PAGING CONTROL)
TLN2450A	GUARD TONE DECODER MODULE (GUARD TONE RELAY CONTROL)
TLN2472B	BASIC CONTROL CHASSIS
TLN2473B	FULLY OPTIONABLE CONTROL CHASSIS (1-RCVR BASE)
TLN2474B	FULLY OPTIONABLE CONTROL CHASSIS (2-RCVR BASE)
TLN2475B	FULLY OPTIONABLE CONTROL CHASSIS (REPEATER RT)
TLN2515B	FULLY OPTIONABLE CONTROL CHASSIS (4 FREQUENCY BASE)
TPN1191A	STANDARD POWER SUPPLY
TPN1192A	BATTERY CHARGER POWER SUPPLY

EPS-35238-O

MSR 2000 CONTINUOUS DUTY STATIONS OPTION CHART

Option	Add	Delete	Description
C11AB	TRN5295A	—	Time-Out Timer
C12AG	HLD4052A	—	Receiver Preamplifier, 146-174 MHz
C12AH	HLD4051A	—	Receiver Preamplifier (132-150.8 MHz)
C13AA	TLN2445A	—	Remote Squelch Control
C14AF	TLN2447A	—	Receive PL Tone On/Off
C15AA	TLN2448A	—	"Wild Card" Option
C28AN	TPN1192A TKN8295A TRN5155A	TPN1191A TRN5355A —	Battery Revert
C31DY	—	TRD6171A TRD6172A	Omit Receiver (132-150.8 MHz) Omit Receiver (146-174 MHz)
C50AC	—	—	Decreased RF Power Output for Maritime Operation (132-174 MHz)
C52AA	TRN5568A TRN5570A	TRN5567A TRN5569A	37" Cabinet
C56AC	TRN5326A	—	Tone Mute Second Receiver (F2-R2)
C63AK	TRN5239A	TRN5240A	DC Transmit PL On/Off
C63AL	—	TLN2449A	Tone Transmit PL On/Off
C71AB	—	TMN6054A	Omit Microphone
C75AB	—	TRN5295A	Omit Time-Out Timer
C83AC	—	TLN2443A TRN5322A TRN5236A TKN8286A	Omit Wire Line Control (Carrier Squelch, Tone Stations)
C84AC	—	TLN2443A TRN5320A TRN5236A TKN8286A	Omit Wire Line Control (PL/DPL, Tone Stations)
C85AB	—	TRN5254A TRN5236A TKN8286A	Omit Wire Line Control (Carrier Squelch, DC Stations)
C86AC	—	TRN5240A TRN5236A TKN8286A	Omit Wire Line Control (PL/DPL, DC Stations)
C113AA	TMN6054A	—	Dynamic Microphone
C116BP	TRD6182A TRN5431A TRN5443A	TRN6172A TRN5430A —	Shield Kit (One Receiver)
C116BQ	TRN5431A TRN5443A TRD6182A	TRN5429A TRD6172A	Shield Kit (Basic)
C116BT	TRD6181A TRN5431A TRN5443A	TRD6171A — —	Shield Kit (146-174 MHz)
C116BU	TRD6181A TRN5443A TRN5474A	TRD6171A TRN5429A —	Shield Kit (132-150.8 MHz)
C140AD	—	—	"AND" Squelch
C143AD	TRN5257A	TRN5254A	Repeater Control (Carrier Squelch, DC Stations)
C143AE	TRN5257A	TRN5240A	Repeater Control (PL/DPL, DC Stations)
C143AF	TLN2446A	—	Repeater Control (Tone Stations)
C144AH	TRN5235A TKN8287A	TRN5236A TKN8286A	4-Wire Line Audio (One Receiver) w/o EIA Rack Mounting
C144AJ	TRN5235A TKN8287A	TRN5237A TKN8286A	4-Wire Line Audio (Two Receivers) w/o EIA Rack Mounting
C149CV	TRN5069A TMN6054A TRN5080A	TRN5068A	Intercom, Metering and Microphone
C150AH	TRN5324A TKN8281A	TRN5254A	RA Base (Carrier Squelch, DC Stations)
C150AJ	TRN5324A TKN8281A	TRN5240A	RA Base (PL/DPL, DC Stations)
C150AK	TRN5324A TKN8281A	—	RA Base (Tone Station)
C158AB	TRN5292A TRN5330A (4)KLN6210A	— — KLN6209A	Multi PL Encoder

MSR 2000 CONTINUOUS DUTY STATIONS OPTION CHART (Cont'd.)

Option	Add	Delete	Description
C164	—	—	EIA Rack Mounting (see Instruction Manual 68P81112E95)
C182AJ	TKN8324A TLD2502A TRN5352A TRN5568A TRN5570A	TRN8323A — — TRN5567A TRN5569A	Add Duplexer (148-174 MHz)
C226AH	TRN5069A TRN5079A	TRN5068A —	Intercom Only
C257AD	TPN1222A TRN9109A TRN9114A	TPN1191A TRN5442A TRN5350A	Multi-Voltage, 50 Hz, Basic
C257AE	TPN1222A TRN9109A TRN9113A	TPN1191A TRN5442A TRN5351A	Multi-Voltage, 50 Hz, Fully Optional
C261AC	(4)TLN8381A TRN5329A	KLN6209A —	Multi-PL Decoder
C262AE	TRN5292A TRN5329A (4)KLN6210A (4)TLN8381A	(2)KLN6209A — — —	Multi-PL Repeater
C263AB	TRN5329A TRN5292A TRN5330A (4)KLN6210A (4)TLN8381A	KLN6209A — — — —	Multi-PL Encoder/Decoder
C266AA	—	KLN6210A	Omit One <i>Vibrasender</i> Reed
C267AA	—	TLN8381A	Omit One <i>Vibrasponder</i> Reed
C269AP	TRN5293A TRN5294A TKN8287A	TRN5236A TKN8286A —	<i>Spectra TAC</i> Operation (Base)
C269AQ	TRN5293A TRN5294A TKN8287A TRN5331A	TLN5236A TKN8286A TRN5324A —	<i>Spectra TAC</i> Operation (Rptr)
C276AA	TRN5075A KLN6209A	TRN5074A —	Simplex PE TA-RB
C276AB	TRN5078A TRN6005A	TRN5077A —	Simplex DPL TA-RB
C323AA	—	TRN5427A	Omit Power Cord
C501AJ	—	KXN1088A	Omit One Transmit Element
C502AH	—	(2)KXN1088A	Omit Two Transmit Elements
C503AE	—	(3)KXN1088A	Omit Three Transmit Elements
C504AE	—	(4)KXN1088A	Omit Four Transmit Elements
C521AR	—	KXN1086B	Omit One Receive Element
C522AM	—	(2)KXN1086B	Omit Two Receive Elements
C523AH	—	(3)KXN1086B	Omit Three Receive Elements
C524AJ	—	(4)KXN1086B	Omit Four Receive Elements
C576AA	—	TLN2442A	Single-Tone Decoder
C601AE	KXN1095A	KXN1088A	Omit One 2PPM Transmit Element
C602AC	(2)KXN1095A	(2)KXN1088A	Omit Two 2PPM Transmit Elements
C603AC	(3)KXN1095A	(3)KXN1088A	Omit Three 2PPM Transmit Elements
C604AD	(4)KXN1095A	(4)KXN1088A	Omit Four 2PPM Transmit Elements
C621AC	KXN1112AA	KXN1086B	One 2PPM Receive Element
C622AB	(2)KXN1112AA	(2)KXN1086B	Two 2PPM Receive Elements
C623AB	(3)KXN1112AA	(3)KXN1086B	Three 2PPM Receive Elements
C624AB	(4)KXN1112AA	(4)KXN1086B	Four 2PPM Receive Elements
C681AB	TPN1223A TRN9114A TRN9110A	TPN1191A TRN5350A TRN5442A	Multi-Voltage, 60 Hz, Basic
C681AC	TPN1223A TRN9110A	TRN1191A TRN5442A	Multi-Voltage, 60 Hz, Fully Optional
C691AA	TRN5972A	TRN5427A	European Power Cord
C692AA	TRN5971A	TRN5427A	United Kingdom Power Cord

GENERAL SAFETY INFORMATION



The United States Department of Labor, through the provisions of the Occupational Safety and Health Act of 1970 (OSHA), has established an electromagnetic energy safety standard which applies to the use of this equipment. Proper use of this radio will result in exposure below the OSHA limit. The following precautions are recommended:

DO NOT operate the transmitter of a mobile radio when someone outside the vehicle is within two feet (0.6 meter) of the antenna.

DO NOT operate the transmitter of a fixed radio (base station, microwave and rural telephone rf equipment) or marine radio when someone is within two feet (0.6 meter) of the antenna.

DO NOT operate the transmitter of any radio unless all RF connectors are secure and any open connectors are properly terminated.

In addition,

DO NOT operate this equipment near electrical blasting caps or in an explosive atmosphere.

All equipment must be properly grounded according to Motorola installation instructions for safe operation.

All equipment should be serviced only by a qualified technician.

Refer to the appropriate section of the product service manual for additional pertinent safety information.

EPS-28750-O

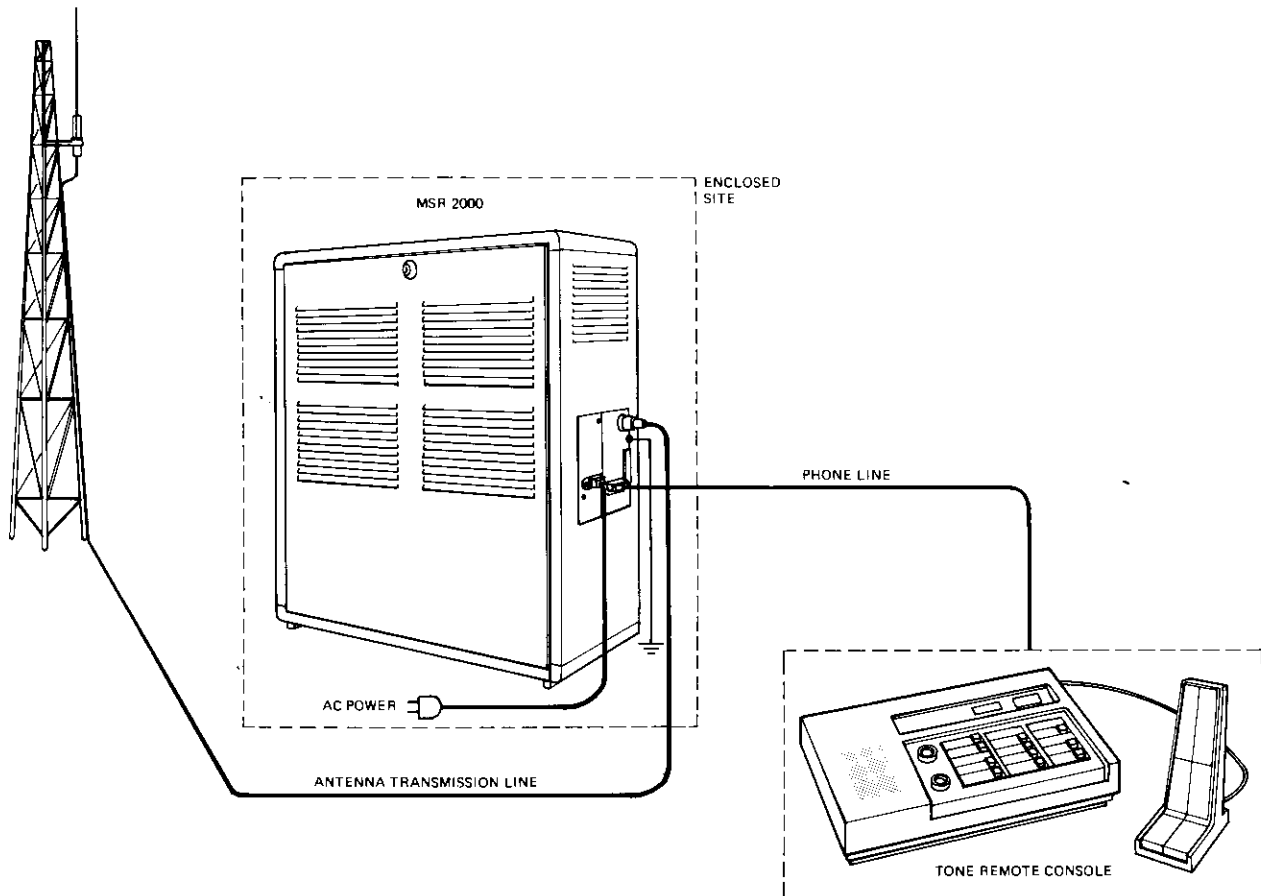
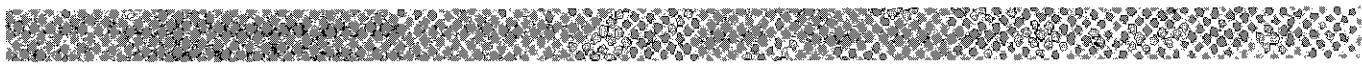

GBEPS-34846-0

Figure 1. Typical System Configuration

1. MANUAL USAGE

This manual describes all aspects of the *MSR 2000* radio station with the exception of remote control and station applications. Separate Control and Audio manual 68P81061E40 describes how these stations are remotely controlled and outlines the various types of base and repeater stations and their applications.

2. INTRODUCTION

The Motorola *MSR 2000* is a free standing, all solid state base station radio. It is dc or tone remote controllable and is available in either a basic or optional version.

The basic version of the *MSR 2000* station provides the same quality and performance specifications as the

DESCRIPTION

technical writing services

1301 E. Algonquin Road, Schaumburg, IL 60196

68P81062E49-A

optionable version. The basic version is intended for those systems that require little change or expansion in the future. See Figure 2.

The optionable version of the *MSR 2000* station satisfies more complex applications requirements. It also has more capacity for future expansion. It has capabilities for tone control of T4R4 channels, repeater application, and two receivers. See Figure 3.

The *MSR 2000* VHF High Band station is available in either continuous or intermittent duty models. Basic or fully optionable models are available for either duty cycle.

3. STATION COMPONENT DESCRIPTION

(Refer to Figure 4.)

3.1 TRANSMITTER

The transmitter generates a frequency modulated rf carrier signal that is delivered to the antenna output connector, part of the station junction box. The transmitter consists of the following items:

- Channel Element — An unheated, temperature-compensated crystal oscillator plug-in module (channel element) provides a stable fundamental rf frequency for the transmitter. One channel element is used for each transmitter frequency.
- Exciter — The exciter provides the low power excitation signal for the power amplifier. An "IDC" (Instantaneous Deviation Control) circuit amplifies

and limits audio signals from the control line to prevent over deviation. Amplified audio is applied to the channel element to produce direct FM modulation. Multipliers in the exciter multiply the channel element frequency to generate the desired output frequency signal(s). A controlled amplifier stage regulates the amount of signal drive to prevent over-dissipation in the final amplifier stages of the power amplifier. In continuous duty stations, an adjustable voltage regulator is used to set the output level of the controlled amplifier stage on the exciter to a certain set level. In intermittent duty stations, a variable voltage from the power control board continuously regulates the output level of the controlled amplifier stage on the exciter.

- Power Amplifier — The low power output of the exciter is amplified to the rated power output of the transmitter in this solid-state power amplifier. Class C amplifiers are used which are cut off until signal drive is applied.
- Power Control Board — In intermittent duty stations, the power control board automatically and instantaneously regulates the transmitter output power. It maintains output power should source voltage vary, and progressively reduces power when the VSWR increases. The output of the board is applied to controlled amplifier stages in the exciter. In continuous duty stations, the power control board performs the same functions as in intermittent duty stations except that the output of the board controls the controlled amplifier stage on the power amplifier.

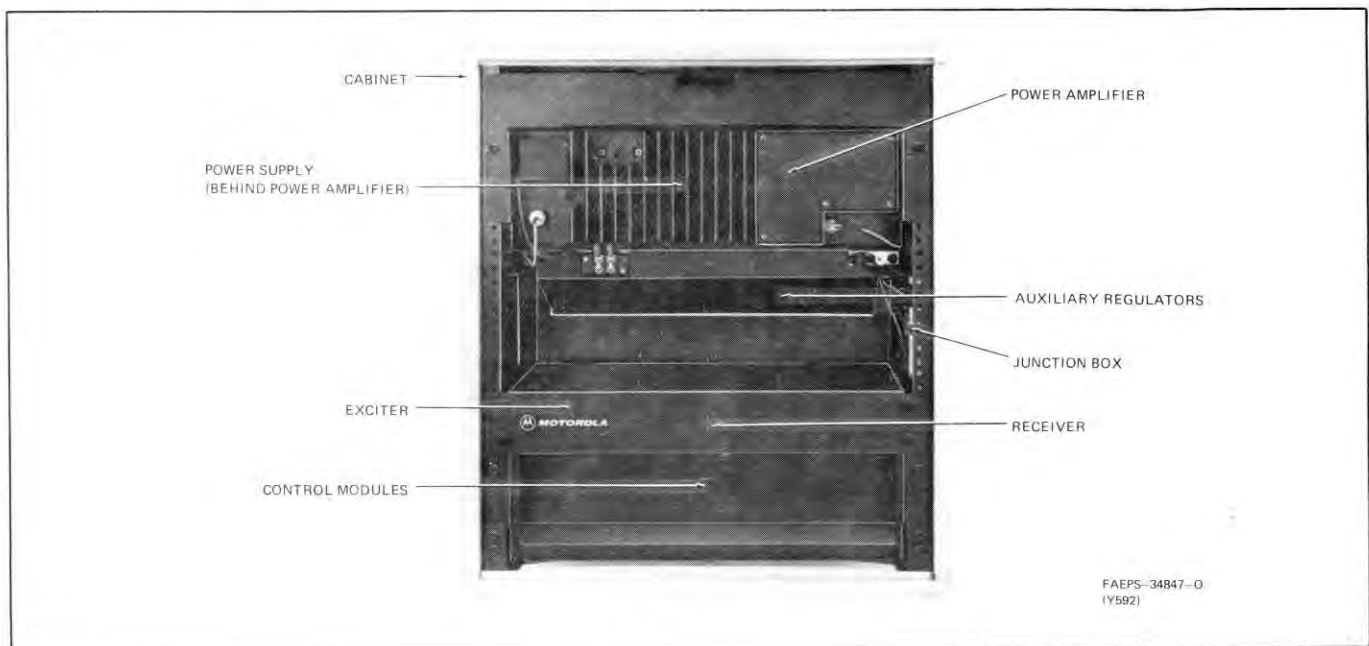

Figure 2. Basic Version of *MSR 2000* Base Station

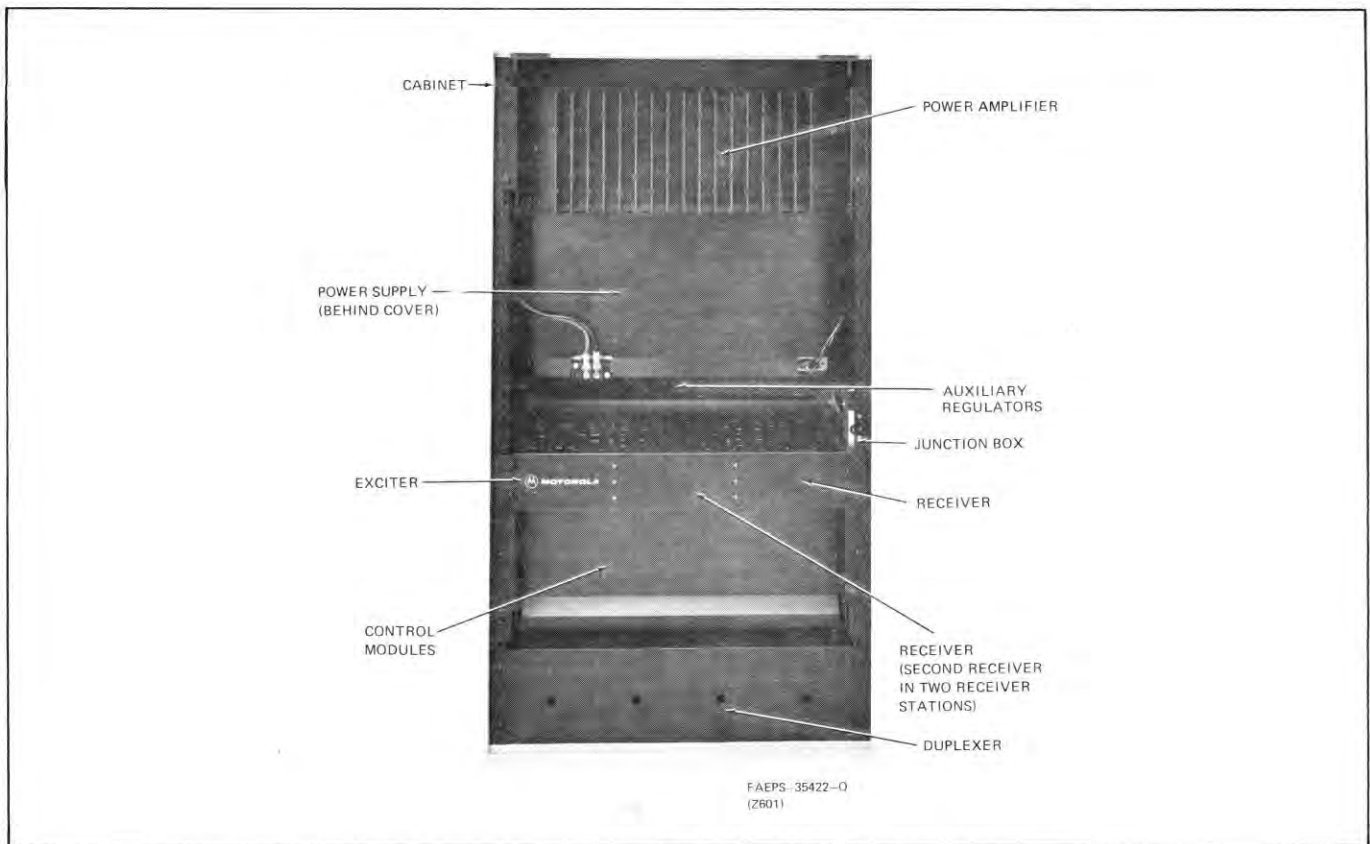

Figure 3. Optionable Version of Continuous Duty MSR 2000 Base Station (Repeater Model With Duplexer Option Shown)

3.2 RECEIVER

The receiver accepts rf carrier signals on a specific channel and provides voice audio in the 300-3000 Hz range. The receiver consists of the following items:

- Channel Element — A plug-in crystal oscillator module (channel element) provides stable frequency control for the frequency of operation. One channel element is required for each receiver frequency.
- Receiver RF & I-F Board — The single-conversion superheterodyne FM receiver includes a preselector (comprised of five cavities) and five crystal filters for excellent selectivity. Two integrated circuit i-f amplifiers and limiters give high sensitivity. A single chip quadrature detector demodulates the audio directly from a 10.7 MHz i-f signal.
- R1 Audio Board — The R1 audio board contains the carrier squelch circuitry and the 1 watt service audio amplifier. When no messages are being received, the squelch circuit turns off the audio amplifiers to eliminate annoying noise in the speaker. A squelch tail eliminator circuit prevents the noise burst at the end of a message for strong signals. For weak signals, the circuit is automatically inhibited to prevent loss of portions of messages. The service audio power amplifier consists of a single chip mounted on the R1 audio board.

- Receiver VOLUME and SQUELCH controls are located on the R1 audio board. The RECEIVER VOLUME control only affects local speaker operation (when used).

NOTE

The SQUELCH control affects local and remote operation.

3.3 POWER SUPPLY

The power supply normally installed in these stations, utilizes a ferro-resonant (constant voltage) transformer and provides all the voltages necessary for operating the station. It automatically corrects for changes in load and input voltage thus maintaining a constant voltage output. An optional supply is available which provides automatic emergency power (+12 V) reverting.

4. UNIQUE FEATURES

Both the basic and optionable versions of the MSR 2000 offer the following design features:

- Front Side Access of All Modules — Major modules tilt forward or slide out so that all necessary test points and metering sockets can be easily reached from the front of the enclosure.

- External Junction Box — AC power, antenna, 12 V dc battery revert option, auxiliary control, and phone line connections are made to an external junction box. No drilling or cutouts are required through the cabinet skin to access internal connections.
- Cooler Operation — Flow-through ventilation and “top-of-the-cabinet” mounting for both the PA and power supply result in cooler operating temperatures, thereby improving station reliability. Air intake is through the front door of the *MSR 2000* and exits on both sides, allowing cooler operation when stacking stations.
- Smaller Size — The *MSR 2000*, at 24 inches high, is much shorter than its predecessor stations, resulting in more space available at the site when stacking stations.
- One-Piece Wrap-Around Sides and Back — The one-piece vinyl clad steel wrapper used for the *MSR 2000* cabinet provides sealed-back enclosure for greater station security, and allows back-to-back installation configurations without the need for access corridors to the rear of the station. No access corridors can result in greater site densities and improved space utilization.

5. OPTIONS

5.1 The following options are available for either the basic or optionable version of the *MSR 2000* station.

- Time-Out Timer (C11 Option)

This limits transmissions to one of five pre-set time periods. These time periods are 1/2, 1, 2, 4, and 8 minutes. The time period desired for a particular system is determined by the user by means of two jumpers. One jumper determines the time period for console-generated transmissions and the second determines the repeat time of a mobile. This module is standard in all RT repeater models.

- RF Preamp (C12 Option)

The preamp doubles the usable sensitivity of the base station receiver, although this sensitivity can be fully realized only in low-noise, interference-free areas.

- 120 V AC/12 V DC With Charge, Alarm, Auto-Revert (C28 Option)

A 12 volt battery can be floated at the output of the station power supply for emergency power use. The battery will provide station power when the AC line fails. When the AC line is functioning it provides float-charging for the battery. Power supply senses

station switchover from 120 V ac to 12 V dc operation when loss of primary power occurs and alerts user via audio alarm.

- Service Intercom and Speaker (C226 Option)

Provides line intercom facilities to simplify servicing of the remote station.

- Test Mic (C113 Option)

Applies to option C226.

- DC Metering With Intercom and Mic (C149 Option)

Provides metering of transmitter and receiver circuits and line intercom facilities (remote control only) to simplify servicing of the remote station.

- Transmit PL On/Off for Paging (C63 and C276 Option)

C63 Option. This module allows any single frequency base station with *Private-Line* squelch to transmit with or without the PL tone on the transmitter at the operator's discretion. A standard paging encoder automatically actuates this function when used in conjunction with a tone console equipped with the corresponding option. This option is not available with the four-frequency remote station.

C276 Option allows transmit code to be different than receive code. Available for both PL and DPL.

- Delete Channel Elements

- Omit Receiver (C31 Option)

- TFN1017A or TFN1018A Crystal Filter (Field Install)

An rf crystal filter adds extra selectivity to the receiver to improve intermodulation protection and desensitization performance.

- AND Squelch (C140 Option)

AND Squelch operation is a means of using both the carrier squelch AND PL tone-coded squelches to operate the receiver. This allows the user to vary the coded squelch sensitivity with the squelch control. It is especially recommended for use in mixed systems where some PL transmitters do not send a reverse burst at the end of each transmission. This results in an annoying squelch tail as the reed coasts to a stop. AND squelch is not recommended for normal PL performance when the mobile may be in a fading area.

- 2 ppm stability on transmit and receive

- Four-Wire Audio Line Driver (C144 Option)

Provides separate audio line capability for duplex operation or two-receiver audio routing.

- 50-Watt Maritime Operation (C50 Option)

- Indoor Cabinet 29" (C92 Option)

This option is applicable to intermittent duty stations only.

- Indoor Cabinet 37" (C52 Option)

This option is applicable to continuous duty stations only.

- TLN5935A Extender Card

- Shield & Filter Kits (C116 Option)

Provides full filtering of all leads and shield covers for base stations only. Included on repeater and two-receiver models as a standard feature.

5.2 The following options are available for only the optionable version of *MSR 2000* stations.

- 4-Reed Multiple *Private-Line* (C158, C261, C262, C263 Options)

Provide 4 PL code capability and are equipped with a full set of *Vibrasender* and/or *Vibrasponder* resonant reeds.

- TLN2442A Singletone Decoder

This module may be used for additional security for repeaters or for repeater selection in multiple-repeater systems. By addition of the TLN4151A Relay Kit, other functions can be controlled by this module. This option is not available with the four-frequency remote station.

- Mute 2nd Receiver (C56 Option)

Allows the user to "mute and unmute" 2nd receiver for extended periods of time. Remember, R1 automatically mutes R2 (R1 priority) when R1 is "active" in the standard two-frequency transmit, two-receiver stations.

- Remote Squelch Set (C13 Option)

Allows selection of station receiver squelch to either of two pre-adjusted settings.

- Wild Card (C15 Option)

This module may be used for any electrically operated function. It provides transistor switch outputs, or, with the addition of one or two relay kits (TLN4151A) will provide two form "C" dry contact outputs. These Wild Card outputs can be used to turn on and off any auxiliary equipment the user may have at or near his base station site. Remember, these functions are done by remote control from his console.

- 4-Cavity Duplexer (C182 Option)

This option, when ordered with a repeater model, provides an in-cabinet 4-cavity duplexer. Cabinet supplied is 29 inches for intermittent duty or 37" for continuous duty and included in this option (132-174 MHz).

- Receiver PL On/Off (C14 Option)

Provides remote control of receive PL on/off. With receive PL off, station reverts to carrier squelch operation.

- *Spectra-TAC* Encoder (C269 Option)

Includes 4-wire audio. Encoder module sends a status tone down control lines when receiver is squelched. This signal is used by the comparator in a *Spectra-TAC* system to effect voting of receivers.

- TKN8281A External Interface Cable

This ten-conductor cable allows routing of available control signals from back of rf control card cage to auxiliary control connector on station junction box.

NOTE

Some of the options described above are not compatible with other options. Option compatibility is computer assigned at the factory. Contact your local Motorola representative for further information.

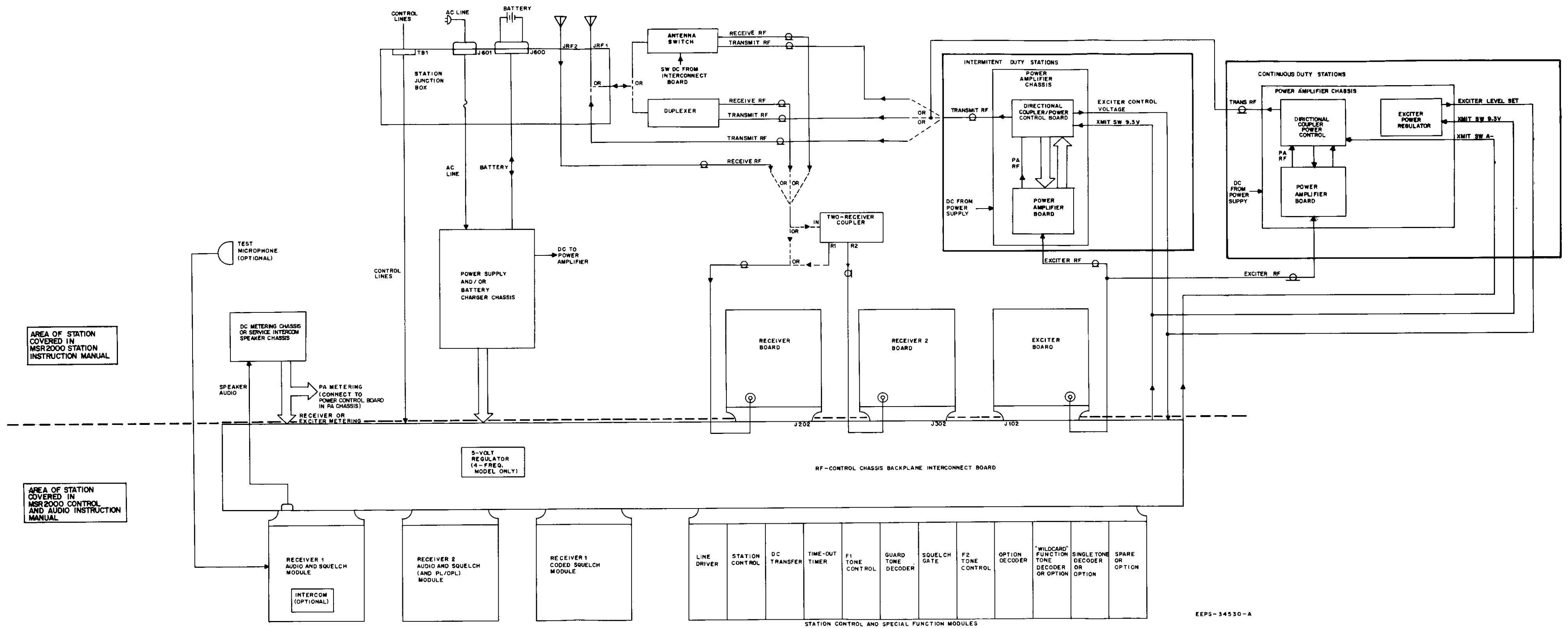

AREA OF STATION COVERED IN MSR2000 STATION INSTRUCTION MANUAL

AREA OF STATION COVERED IN MSR2000 CONTROL AND AUDIO INSTRUCTION MANUAL

EEPS-34530-A

Figure 4. Simplified Block Diagram

DESCRIPTION



MOTOROLA INC.

**Communications
Group**

LIGHTNING PROTECTION RECOMMENDATIONS

The conditions that make a site desirable for two-way radio are the same as those that make a site an excellent target for lightning. Proper lightning protection can completely prevent equipment damage in all but the most severe strikes and even then keep the equipment damage at a minimum. Lightning protection basically consists of preventing the strike from entering the equipment room and then preventing damage to the equipment from induced voltages and currents on power and control lines to the equipment. The following suggestions will help protect valuable radio facilities. Some products already incorporate certain suppressors as standard equipment. In these cases, additional protection is not normally required, unless dictated by unique site considerations. When such unique situations occur, consult the appropriate area office for further information.

- Use at least eight-foot long copper clad ground rods. Multiple ground rods are better than one especially in dry climate or sandy-rocky soil areas.
- Bring the transmission line off the tower with the sharpest bend permitted by the manufacturer's specifications and make a solid bond between the tower and transmission line sheath just prior to the bend. The sharp bend acts as a spot impedance to the extremely high strike current. This shunts more of the strike current into the tower ground rather than into the equipment. Use no more or no less than the minimum bend radius wherever the transmission line changes direction and introduce a change of direction at every reasonable opportunity. Then, ground the transmission line sheath at the antenna side of each bend in the transmission line.
- Keep the tower grounding resistance as low as possible. The lightning stroke current belongs in the tower structure and grounding system, not on the transmission line.
- Provide additional grounding to the transmission line sheath wherever possible. Make it a point to ground the transmission line where it is supported on poles and where it enters a building.

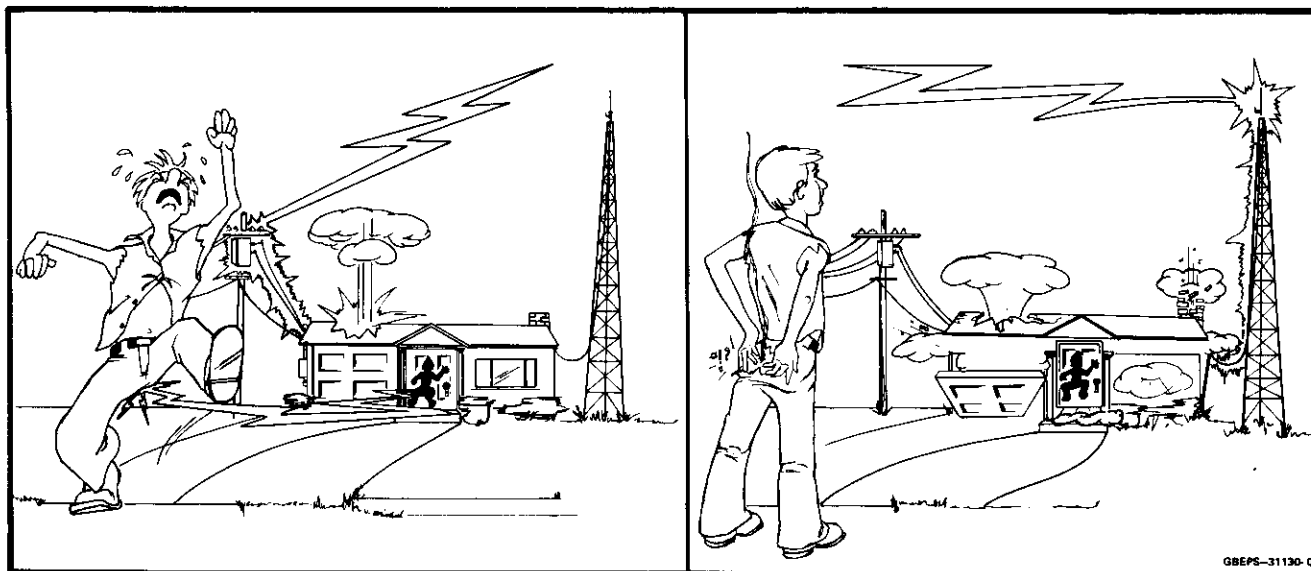

Unprotected power/control lines and antenna installations can be hazardous to equipment and personnel.

- It is wise to take at least part of the transmission line through a length of grounded conduit.
- **Bond all equipment cabinets together to a single point.** Then, ground that point to a grounding rod network using as short and as straight a ground wire as possible. If bends in the ground wire are necessary, make them as large a radius as practical.
- Transmission lines should be brought into the equipment cabinets adjacent to the single point ground connection where a good low impedance bond can be made with the transmission line sheath.
- Install a gas tube protector between the equipment cabinet ground and AC-neutral where it enters the equipment cabinet. Install gas tube protectors where the control lines enter the building and at the point of entry into the equipment cabinet. Also, install gas tube protectors wherever control lines enter a building and install additional protectors as close to the remote control console as possible.
- Keep ground wires from gas tube protectors to ground rods or perimeter grounds as straight and short as possible. Avoid sharp bends in ground wires.
- Never bundle a ground wire with any other cabling or wiring. Also, never run a ground wire along any metal wall, along any electrical conduit, or inside a conduit.

Remember, the lower impedance the grounding system is in relation to the equipment being protected, the greater the protection afforded to the equipment. Keep the lightning strike current in the grounding network; not running through the equipment to ground.

RECOMMENDED PROTECTORS

The devices listed below are available from your local Motorola Parts Center. Other devices are available from different manufacturers for special applications and may be used in place of those listed herein. Installation instructions are generally packed with each device. The following listing contains phone line suppressors, ac line surge protectors, coaxial cable in-line lightning arrestors, and coaxial cable ground clamp kits. Refer to the Motorola Buyers Guide for additional information.

PHONE LINE SUPPRESSORS

TRN8187A Single Line Suppressor, 3-electrode gas tube protector

TRN4589A Dual Line Suppressor, 3-electrode gas tube protector

RRX4021B Single Line Suppressor, 3-electrode gas tube protector

AC LINE SURGE PROTECTORS

TLN4399A AC Line Surge Protector, 117 V ac line, 7/8" x 14 conduit hole mounting

TLN5920A AC Line Surge Protector, 240 V ac line, 7/8" x 14 conduit hole mounting

RRX4017A AC Line Surge Protector, 117 V ac, 10 Amp, single phase, screw terminal connector block

RRX4018A AC Line Surge Protector, 117 V ac, 10 Amp, single phase, 3-prong plug and receptacle

RRX4019A AC Line Surge Protector, 117 V ac, 15 Amp, single phase, 3-prong plug and receptacle

RRX4020A AC Line Surge Protector, 220/240 V ac, 30 Amp, single phase

COAXIAL CABLE IN-LINE LIGHTNING ARRESTORS

RRX4024 UHF type connector

RRX4025 "N" type connector

RRX4032 Tower Mount Kit

COAXIAL CABLE GROUND CLAMP KITS

ST-788 For 1/2" jacketed heliax and pipe or grounding rod

ST-853 For 7/8" jacketed heliax and pipe or grounding rod

ST-789 For 1/2" unjacketed heliax, includes bushings for better contact without collapsing line

ST-790 For 7/8" unjacketed heliax, includes bushings for better contact without collapsing line



1. FCC REQUIREMENTS

IMPORTANT

FCC regulations state that:

1. Radio transmitters may be tuned or adjusted only by persons holding a general class commercial radio-telephone operator's license or by personnel working under their immediate supervision.
2. The rf power output of a radio transmitter shall be no more than that required for satisfactory technical operation considering the area to be covered and local conditions.
3. The frequency, deviation, and power of a base station transmitter must be maintained within specified limits. (It is recommended, therefore, that these three parameters be checked before the station is placed in service.)

REMEMBER

The efficiency of the equipment depends upon a good installation.

2. INSPECTION

Inspect the equipment thoroughly as soon as possible after delivery. If any part of the equipment has been damaged in transit, report the extent of damage to the transportation company immediately.

3. PLANNING THE INSTALLATION

Since a good installation is important to obtain the best possible performance of the communications

system, carefully plan the installation before actual work is started. Location of the station in relation to power, control lines, the antenna, and convenience and access for servicing should be considered. The cabinet dimensional detail diagrams show the size of the various cabinets for planning the space requirements. Read the entire procedure and the many suggestions offered to help you plan your installation. Make sure all tools, equipment and facilities are available when the installation is begun.

4. VENTILATION

The radio equipment is operated without forced ventilation. The cabinets have been designed with vents which allow outside air to be drawn in through louvered openings in the door and expelled through an opening in the cabinet wrapper (sides). The heated air rising in the cabinet causes a natural draft. Therefore, it is essential that the openings be kept free of obstructions so the air flow will not be restricted. Also, site installations require that adjacent cabinets be located a minimum of six inches from all vents.

NOTE

Sufficient clearance must also be provided at the front of the cabinet to allow for servicing and component removal.

Refer to Figure 1 for cabinet dimensional details.

5. INSTALLATION OF 24-, 29-, 32-, AND 37-INCH INDOOR MSR 2000 CABINETS

- 5.1 Refer to Figure 1 for cabinet dimensional details.
- 5.2 The cabinet should be located on a solid, level surface convenient to the power source and the rf transmission line. The rf transmission line should be kept as short as possible to minimize line losses.
- 5.3 All antenna power and control lines are connected at the junction box located on the right side of the cabinet.

INSTALLATION

Figure 1. Cabinet Dimensional Details

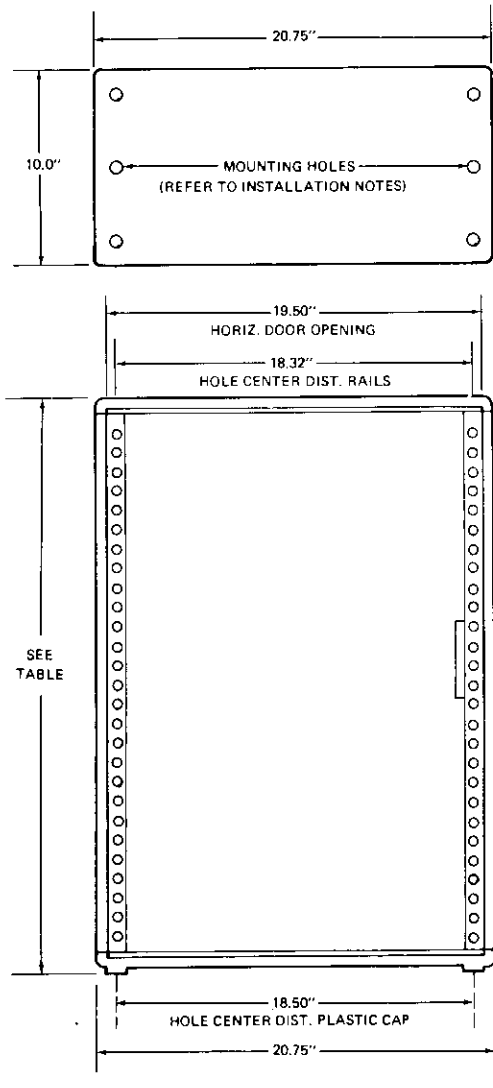

CABINET TOP BOLTS

QTY.	PART NO.	DESCRIPTION
4	0310943J41	M8 X 16 MM TORX® BOLT
2	0310943J45	M8 X 40 MM TORX® BOLT

HEIGHT DIMENSION TABLE

CABINET SIZE	HEIGHT DIMENSION
24-INCH	24.04 INCHES
28-INCH	28.29 INCHES
32-INCH	32.04 INCHES
37-INCH	37.29 INCHES

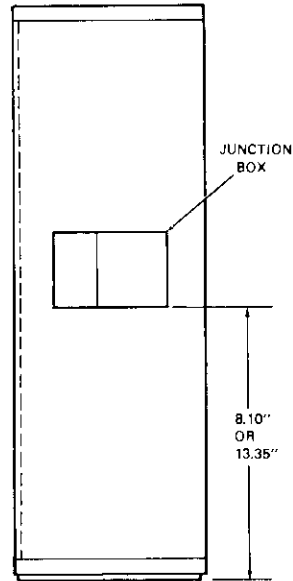

INSTALLATION NOTES

LOCATION

CABINET REQUIRES A MINIMUM OF 6-INCHES CLEARANCE BETWEEN LOUVERED SIDE-PANELS AND EXISTING SURFACES FOR PROPER VENTILATION. ALLOW A MINIMUM OF 12-INCHES ACCESS SPACE AT THE CABINET DOOR.

FIXED MOUNTING (SEE DETAIL A)

IF DESIRED (BUT NOT NECESSARY UNLESS STACKING CABINETS), THE CABINET CAN BE SECURED TO THE FLOOR USING TWO M8 OR 5/16" BOLTS OF THE APPROPRIATE LENGTH INSERTED THROUGH THE CENTER HOLES OF THE BOTTOM RAILS.

STACKING CABINETS (SEE DETAIL B)

- REMOVE THE MIDDLE TWO BOLTS (M8 X 40 MM) FROM THE TOP COVER OF THE BOTTOM CABINET AND SAVE THE BOLTS.
- CAREFULLY LIFT AND PLACE THE SECOND CABINET IN POSITION ON TOP OF THE LOWER CABINET.
- TILT OUT THE CARD CAGE IN THE TOP CABINET AND INSERT THE TWO BOLTS REMOVED EARLIER FROM THE BOTTOM CABINET INTO THE CENTER HOLES OF THE BOTTOM RAILS AND SCREW THEM INTO THE TOP RAILS OF THE BOTTOM CABINET.

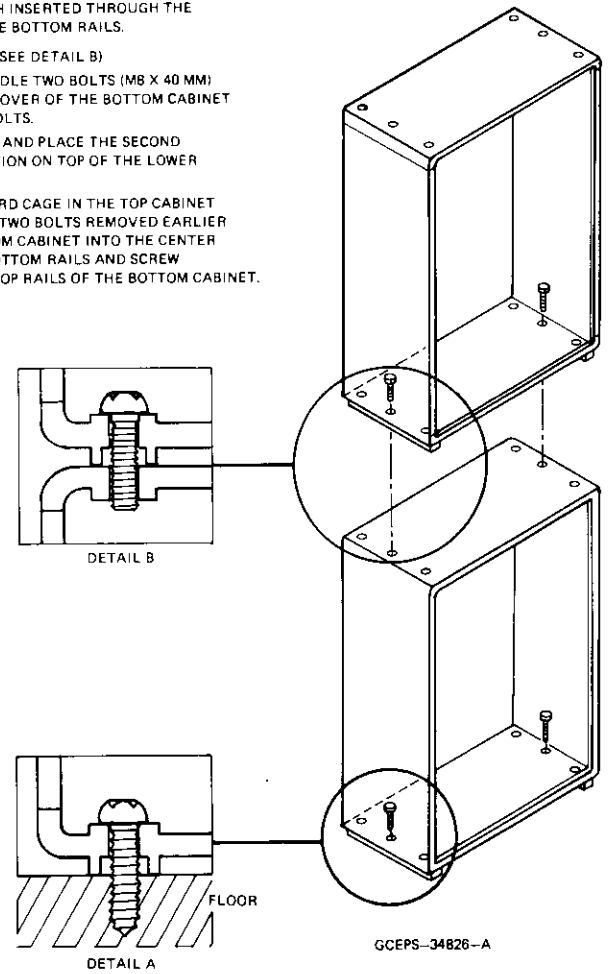

GCEPS-34826-A

CAUTION

It is recommended that no additional holes be drilled into the cabinet.

5.4 Refer to Figure 1 for mounting and stacking details.

6. ANTENNA CONNECTIONS

6.1 INTRODUCTION

6.1.1 The antennas and transmission lines are not part of the station. Therefore, antenna installation instructions are not included in this section. Follow the instructions shipped with the antenna for applicable information.

6.1.2 In its primary application, the station is used for communications with mobile radios. Thus, antennas having omni-directional characteristics are desirable. However, if the station is located at the outer perimeter of a communications area, or if it is to be used for communications with a fixed station, an antenna with specific directional characteristics may be more suitable. FCC requirements may also dictate the type of antenna to be used.

6.1.3 All coaxial antenna cables connect to UHF coaxial connectors located on the junction box. For repeater stations without the optional duplexer, two antennas are required; one for the transmitter and one for the receiver. For repeater stations with the optional duplexer, only one antenna is required. Refer to Figure 2 for antenna connection details.

7. AC INPUT POWER AND GROUND CONNECTIONS

7.1 INTRODUCTION

7.1.1 All stations should have a separate power circuit from a 10-ampere (minimum), 120-volt ac, 60 Hz power source. The power lines should be installed in accordance with local electrical codes. A substantial earth ground must be provided as close to and in as straight a line as possible with the ground terminal provided on the junction box. Do NOT consider the electrical outlet box as a substantial ground. Refer to the Lightning Protection Recommendation sheet, 68P81111E17 elsewhere in this installation section for additional grounding recommendations.

7.1.2 The primary ac power line may be installed prior to installation of the cabinet and terminated near the location chosen for the station if the

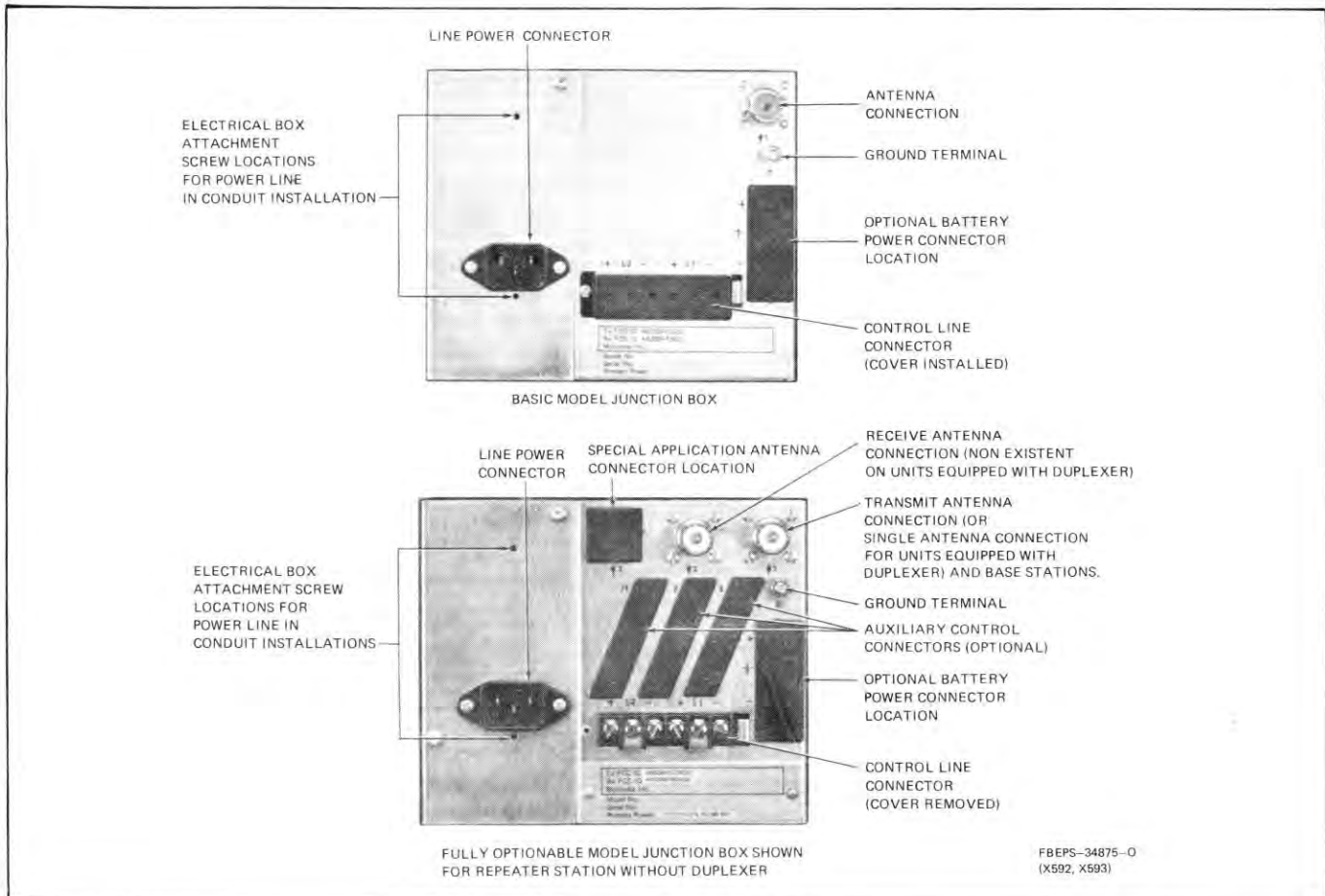

Figure 2. External Connection Details

power line cord supplied with the station is to be used. If the station power is to be supplied by conduit wiring, the station must be installed first. Separate procedures are provided for each type of installation in the following.

7.2 STATION INSTALLATION USING POWER LINE CORD SUPPLIED WITH THE STATION

Step 1. Install the station as described in paragraph 5.

Step 2. Connect the female plug of three-wire ac line cord to the power connector on the junction box. See Figure 2.

Step 3. Connect the male plug of the three-wire ac line cord to the wall outlet provided near the station.

Step 4. Connect the ground terminal on the junction box to a substantial earth ground located as close as possible to the station and in as straight a line as possible with the ground terminal.

NOTE

A power ON-OFF switch is not provided on the station, therefore, the equipment is immediately operational when the power cord is plugged into a live ac outlet.

WARNING

Even if a three wire grounded primary ac power source is available, the radio equipment **must be grounded** separately to prevent electrical shock hazards and provide lightning protection.

7.3 STATION INSTALLATION USING CONDUIT FOR PRIMARY POWER CONNECTION

The *MSR 2000* junction box has provisions which allow ac power connection to the station using conduit. The following installation procedure is recommended.

Step 1. Remove the two screws attaching the ac input connector (J611) to the junction box and carefully pull the connector away from the junction box.

Step 2. Cut the wires as close as possible to the ac input connector (J611).

Step 3. Strip the insulation from the wires a sufficient length to allow connection to the incoming power leads.

Step 4. Attach a 4-1/8" x 2-3/8" x 1-1/2" electrical box (Appleton Catalogue No. 184-E universal code 69351 or equivalent box extension ring, not supplied) to the junction box using two #6-32 x 5/16" long self tapping washer head screws in the holes provided. See Figure 2.

Step 5. Attach the conduit to the electrical box and make the electrical connections. (It may be desirable to provide an ON-OFF switch or convenience outlet on the electrical box).

NOTE

The primary power wire colors used in the *MSR 2000* conform to international standards. Refer to the following cross reference table as required.

Power Connection	International STD Wire Color	US Standard Wire Color
Live	Brown	Black
Neutral	Blue	White
Ground	Green/Yellow	Green

Step 6. Attach a suitable cover to the electrical box.

8. OPTIONAL DC INPUT POWER CONNECTIONS

Connection of the optional dc input power requires assembly of the TRN5155A External Battery Cable Kit. This kit includes a fuse block assembly that must be mounted to the base station along with wires and terminals that must be assembled and connected to the external battery. Install as follows:

Step 1. Determine the length of black #8 gauge wire required to run from P605 directly to the battery negative terminal. Route and cut the black wire to length. A ring tongue lug is provided to facilitate connecting the wire to the battery.

NOTE

The TRN5155A External Battery Cable kit contains 10 feet of red and black #8 gauge wire. Runs longer than 10 feet are not recommended for efficient battery operation. If runs longer than 10 feet are necessary, increase the wire gauge by 3 AWG for each increase of 10 feet in run length.

Step 2. Make sure all power is disconnected from the station.

WARNING

Refer to Power Supply section for proper battery voltage setting before connecting the station to the battery.

Step 3. Connect the blue connector (P605, part of the TRN5155A External Battery Cable Kit) into the optional battery power connector (J605) located on the junction box. See Figure 2.

Step 4. Remove the fuse from the fuse holder and mount the fuse holder (supplied with the TRN5155A

kit) to the battery rack as close as possible to the battery using the two 8 x 1-1/4" tapping screws provided.

Step 5. Determine the length of red #8 gauge wire required to run from P605 to the fuse block. Route and cut the red wire to length. Attach the red wire to the fuse block.

Step 6. Use the cut off piece of red wire to connect the fuse block to the battery. A ring tongue lug is provided to facilitate connecting the wire to the battery. After checking that all connections are secure and that polarity is proper, install the fuse removed in Step 4.

9. OPTIONAL MODE JUMPERING

9.1 GENERAL

9.1.1 Many station modes of operation are determined by jumper connections at the time of installation and are described in the following paragraphs.

9.1.2 Additional jumpers used with the station are identified and described in applicable sections elsewhere within this instruction manual.

9.2 TIME-OUT TIMER MODULE

Base stations or repeaters equipped with a time-out timer module prevent unintentional continuous transmission. The timing jumpers on the module may be connected for 1/2, 1, 2, 4 or 8 **minute** operation. In repeaters, the time-out timer will reset each time a new input signal arrives at the station, whether or not the dropout delay generator has shut off the transmitter. Repeater time-out time and line transmit time periods may be selected independently with the repeater select jumper and the line select jumper.

9.3 SQUELCH GATE

In repeater stations, the dropout delay generator in the squelch gate module prevents the transmitter from shutting off during loss or excessive fade of input signal for the length of time preset. The jumper can be set for 0, 1, 2, 4 or 8 **second** operation.

9.4 TWO-RECEIVER STATIONS

9.4.1 Stations equipped with two receivers can be connected for receiver #1 priority or receiver #2 priority if desired. A signal received on the priority receiver automatically mutes the other receiver. These jumpers are located on the line driver module.

Receiver #1 priority — JU18 OUT
JU24 IN
Receiver #2 priority — JU18 IN
JU24 OUT

9.4.2 Jumpers in the line driver module also allow receiver #2 to be partially muted (audio attenuation) if desired, rather than the full muting as shipped from the factory. Attenuation of 10 dB, 20 dB or 30 dB in respect to the unmuted condition are possible by jumper connections as follows.

30 dB attenuation — JU25, 26 IN
JU27 OUT
20 dB attenuation — JU25 IN
JU26, 27 OUT
10 dB attenuation — JU25, 26 & 27 OUT

9.4.3 Receiver #2 mute attenuation is a standard feature of dc controlled stations and optional on tone control.

10. CONTROL LINE CONNECTIONS

10.1 INTRODUCTION

10.1.1 The station can be controlled from a remote point over wire line circuits. Simplex audio is used, meaning that the remote point can send audio to the station or receive audio from the station, but not both at the same time. Therefore, a single audio pair will suffice. For dc remote control operation, the wire line must provide dc continuity for carrying the dc control currents. This must be the same pair that carries the transmit audio. For tone remote control operation the audio pair also carries the audio control tones.

10.1.2 Four-wire audio operation, wherein transmitter audio and receiver audio are carried on separate wire pairs, is possible with the optional line driver/4-wire, 2-receiver audio module (this module is also used in 4-wire, single receiver application). In such operation, line 1 is the transmit pair and line 2 is the receive pair.

10.1.3 In stations with two receivers and four-wire audio, jumpers can be arranged to use line 2 to carry the audio from receiver #2 only if desired.

10.2 LINE SPECIFICATIONS

The audio wire line(s) must meet the following specifications for acceptable radio communications. Verify the characteristics of leased telephone lines with the company providing the service before installation.

10.2.1 DC Remote Control Operation

Audio Line Requirements

1. Frequency Response:
500 to 2500 Hz
2. Impedance:
600-ohm balanced line

DC Line Requirements

1. DC resistance 0 to 8000 ohms
2. Must have dc continuity

10.2.2 Tone Remote Control Operation

Frequency response: 500 to 2500 Hz
Frequency translation error: ± 10 Hz max.
Impedance; 600-ohm balanced line
Signal-to-noise: 35 dB min.

Chart of Maximum Input and Loss

Phone-Company Specified Maximum Input	Maximum Phone Line Loss Usable with Remotely-Controlled Radio
5 vu (11 dBm)	29 dB
0 vu (6 dBm)	24 dB
-8 vu (-2 dBm)	16 dB

10.3 INSTALLATION

10.3.1 General

The control line may be installed prior to installation of the cabinet and terminated near the location chosen for the station. Conduit or two-wire cable can be used from this termination to the station junction box control line connector.

10.3.2 Specific Connection Information

Connect the 600-ohm lines to the screw terminals on the junction box control line connector as shown in Figure 2. (In 2-wire applications, use line 1 connections.)

10.3.3 DC Control Line Levels

When the dc control line is initially connected, it must be tested to assure that its loop resistance is low enough to allow sufficient current for remote operation. Use the following test procedure.

Step 1. Connect a dc milliammeter in series with the dc control line.

Step 2. Have the operator press the push-to-talk switch at the remote control console.

Step 3. The current must be at least +5.5 mA to key the transmitter and at least +10 mA for two-frequency transmitters. Check to see that the current is positive and not negative and that the station is actually keyed. Adjust the remote control console for F1 line current until +5.5 mA is achieved. For a two-frequency transmitter, adjust the remote control console for F2 line current of 10 to 12 mA. If the line loop resistance is too high, the maximum line current from the console will not key the transmitter. There are two alternatives to correct this problem.

- Use a pair of lines having lower resistance while maintaining proper audio response, or
- Use an alternate pair of lines with lower resistance to carry dc current only. This pair need not have good audio loss or response characteristics.

Adjust the line current for *Private-Line* disable at the remote control console for -2.5 mA, if a *Private-Line* model is being adjusted.

10.3.4 Tone Control Line Levels

The control tone levels for the remotely controlled functions are adjusted at the remote control console. No additional adjustments are required.

11. CONTROL LINE LEVEL ADJUSTMENT

11.1 GENERAL INFORMATION

11.1.1 Most telephone companies limit the maximum signal amplitude which they will allow on their lines. The most common maximum level is 0 vu (volume units); check the telephone company for the maximum level to be used on your lines. Adjust the audio levels to the maximum permissible level which will give the best signal-to-noise ratio. For lines not subject to telephone company restrictions, set line level to +5 vu.

11.1.2 The vu is the measurement for speech and can be measured only with a vu meter. This meter has special ballistics to control the rise and fall time and the overshoot of speech signal voltage. Since speech signals fluctuate so rapidly, special metering techniques are required. The pointer of a vu meter responds to a series of "kicks" or deflections of varying amplitude. Over a period of time, a majority of peaks will reach approximately the same level. There will be a few very strong peaks which will exceed this level and a few peaks of lower level. These are ignored and the measured speech level equals the majority of the "kicks" or peaks reached. Measurements show that the instantaneous peaks of a speech signal are about 10 dB higher than the vu value (the instantaneous peaks of a 0 vu speech signal will equal the peaks of a sine wave signal of ± 10 dBm magnitude). Of course, a sine wave signal of ± 10 dBm would produce a much greater volume because every cycle of the signal goes to peak amplitude.

11.1.3 Adjustment of the audio line levels is very difficult using actual speech signals which fluctuate so greatly. A sine wave signal (1000 Hz continuous tone, for example) is much easier to use for adjustments. However, sine wave signals are measured in dBm and the telephone company specifies the maximum signal level in vu. THERE IS NO CONVERSION FROM VU TO DBM OR VICE VERSA when measuring speech. Speech cannot be measured in dBm or converted into dBm. The dBm is a unit to measure the sine

wave power as referenced to 1 milliwatt of power. The power of a speech signal of a particular vu is not defined and is different for different speakers. **IT IS POSSIBLE TO CALIBRATE A VU METER BY USING A SINE WAVE SIGNAL ON THE 600-OHM LINE, THEN MEASURING THE SAME SIGNAL IN DBM WITH A VOLTMETER.** On a 600-ohm line, a sine wave signal that will produce a 0 vu reading will measure 0 dBm on a voltmeter. This does not mean that 0 vu is equal to 0 dBm. Remember, the peaks of an actual 0 vu speech signal will have instantaneous peaks of +10 dBm amplitude.

11.1.4 We would normally conclude that sine wave signal levels would be adjusted 10 dB higher than the vu level specified for the line. **EXPERIMENTAL MEASUREMENTS HAVE PROVEN THAT SINE WAVE SIGNAL LINE LEVELS SHOULD BE 6 DB HIGHER THAN THE VU LEVEL SPECIFIED FOR THE LINE (+5 vu speech level should be adjusted for +11 dBm tone level; 0 vu speech level should be adjusted for +6 dBm tone level).**

600-Ohm Line VU, dBm, and Voltage Equivalency Chart

If Maximum Speech Level For Line Is	Adjust Tone Line Level For (1 mW ref)	Voltage Equivalent
+5 vu	+11 dBm	2.78 V
+2 vu	+8 dBm	1.94 V
0 vu	+6 dBm	1.54 V
-2 vu	+4 dBm	1.22 V
-4 vu	+2 dBm	0.97 V
-6 vu	0 dBm	0.77 V
-8 vu	-2 dBm	0.61 V
-10 vu	-4 dBm	0.48 V
-12 vu	-6 dBm	0.38 V
-14 vu	-8 dBm	0.30 V
-16 vu	-10 dBm	0.24 V
-18 vu	-12 dBm	0.19 V
-20 vu	-14 dBm	0.15 V
-22 vu	-16 dBm	0.12 V
-24 vu	-18 dBm	0.09 V
-26 vu	-20 dBm	0.07 V

11.2 ADJUSTMENTS

11.2.1 General

11.2.1.1 A local speaker at the station may be used for testing and level settings. If the station is equipped with built-in metering, it includes a local speaker. If not, the speaker in a Motorola portable test set may be used by connecting the test set to the control receptacle on the unified chassis interconnect board. Otherwise, a mobile speaker can be connected to the local speaker pins (pins 22 and 23 of R1 audio module on the unified chassis interconnect board). The receiver VOLUME control sets the audio level at the local speaker only.

11.2.1.2 Exciter audio should be measured at the input to the exciter and adjusted for the sensitivity value stamped on the exciter's sensitivity label located on the inside of the control card cover. This level should be measured at pins 11 and 12 of the exciter board plug.

11.2.1.3 *Private-Line* receivers must be PL disabled during adjustments by using the PL DISABLE switch on the station control module. In *Private-Line* repeaters, the squelch gate must also be set for carrier squelch operation during adjustments by connecting jumper JUI4 to the active pin and JUI5 to the dummy pin. Be sure to return the jumpers to the PL condition after adjustments are complete.

11.2.1.4 If the station is equipped with a single-tone decoder module for repeater access, unplug the single-tone decoder during adjustments.

11.2.2 Repeater Level Setting

Step 1. Set the receiver SQUELCH control at squelch threshold.

Step 2. Inject an on-frequency carrier signal into the receiver antenna input. Adjust the signal level to 20 dB quieting.

Step 3. Adjust the REPEATER SQUELCH KEY control (squelch gate module) so the transmitter just keys.

Step 4. Modulate the receiver input with a 1000 Hz tone at ± 5 kHz deviation. Adjust the REPEATER LEVEL control (squelch gate module) so the exciter audio input (measured at pins 11 and 12 of the exciter board) is the value stamped on the exciter sensitivity label (modulator sensitivity +6 dB or approximately ± 5 kHz transmitter deviation).

Step 5. On PL repeaters, return jumpers JUI4 and JUI5 to the PL condition.

11.2.3 Wire Line Controlled Base Stations and Repeater Stations

11.2.3.1 Determine the maximum allowable audio level permitted on the lines and set line audio level to this amplitude. Refer to the 600 ohm, vu, dBm and voltage equivalency chart for tone levels to be used.

NOTE

The following procedures assume the +5 vu speech level (+11 dBm tone level). For other speech levels, use a tone level 6 dB higher than the vu level (for 0 vu use +6 dBm); refer to the equivalency chart. On some lines, tone levels are not permitted to exceed the speech levels, even for short test tones (for example, maximum speech level of 0 vu and maximum tone level of 0 dBm). When such regulations apply, use the special procedures for low level test tone.

11.2.3.2 As mentioned previously, the lines used to carry audio have an ac impedance of 600 ohms. The amplitude of signals is most conveniently measured in dBm. Zero dBm is equal to 1 milliwatt across 600 ohms. Most audio voltmeters, such as the Motorola transistored ac voltmeter, are calibrated to read directly in dBm when measuring across a 600-ohm impedance. Never use a volt-ohm meter or a multimeter.

Step 1. Apply a 1000 Hz audio tone to the remote control console at a level sufficient to drive the amplifier into compression. Adjust the output of the remote control console for +11 dBm (or maximum allowable audio level) at its output terminals. If the level at the station is above 0 dBm, remove JU1 on the station control module.

Step 2. Adjust the XCTR LEVEL control (state control module) so the exciter audio input (measured at pin 11 and 12 of the exciter board) equals the value stamped on the exciter. (Modulator sensitivity plus 3 dB or approximately +5 kHz transmitter deviation.)

Step 3. Remove the 1000 Hz audio tone.

Step 4. Set the receiver SQUELCH control for squelch threshold.

Step 5. Inject a 1000 mV carrier frequency signal into the antenna input of the receiver. Modulate the signal with a 1000 Hz tone at + kHz deviation.

Step 6. Adjust the LINE 1 OUTPUT/line driver module) for +11 dBm (2.8 V) or maximum allowable audio level as measured with an audio voltmeter across the line 1 terminals. If four-wire audio operation is used, with the receiver output applied to line 2, adjust the LINE 2 OUTPUT control while measuring across the line 2 terminals.

Step 7. If the station has two receivers, both feeding to line 1, set the LINE 1 OUTPUT control as specified with a +5 kHz modulated carrier signal injected into receiver 1. Next, inject a ± 5 kHz modulated carrier into receiver 2. If the line output on the voltmeter changes by more than 2 dBm, readjust the potentiometer on the receiver 2 audio and squelch board to match the receiver 1 reading.

Step 8. If the station has two receivers, each on a different line, adjust LINE 1 OUTPUT with a modulated carrier injected into receiver 1, and adjust LINE 2 OUTPUT with a modulated carrier injected into receiver 2.

11.2.4 Special Procedure for Low Level Test Tone

NOTE

The following procedure is written for the vu speech level and 0 dBm test tone level, but other levels may be used by substituting appropriate levels (levels across the 600-ohm load should be 6 dB higher than the specified line level).

Step 1. Terminate the remote control console in a 600-ohm load resistor rather than the line.

Step 2. Apply a 1000 Hz audio tone to remote control console at a level sufficient to drive the amplifier into compression.

Step 3. Connect an audio voltmeter across the 600 ohm load resistor and adjust the line output for +6 dBm.

Step 4. Reduce the 1000 Hz audio tone input until the voltmeter reads 0 dBm.

Step 5. Remove the 600 ohm load resistor and reconnect the line. Readjust the line output for 0 dBm across the line. Do not change the 1000 Hz tone level.

Step 6. Connect the audio voltmeter to the exciter audio input at the station and adjust the XCTR LEVEL control for 6 dB less than the value stamped on the exciter.

Step 7. Disconnect the line at the station and connect a 600 ohm load resistor in its place.

Step 8. Apply a 1000 μ V carrier signal to the receiver antenna terminal from an FM signal generator. Modulate the carrier signal with a 1000 Hz tone at ± 5 kHz deviation.

Step 9. Connect an audio voltmeter across the 600 ohm load resistor and adjust the LINE 1 OUTPUT control for +6 dBm.

Step 10. Reduce the deviation until the voltmeter reads 0 dBm.

Step 11. Remove the 600 ohm load resistor and reconnect the line. Readjust the LINE 1 OUTPUT for 0 dBm as measured across the line.

1. INTRODUCTION

1.1 This section of the manual details procedures required in the overall maintenance of the station. Specific troubleshooting and alignment procedures are given in the appropriate section of this manual, such as receiver, transmitter, etc. Maintenance checks for control modules are given in the applicable module section in the separate Control and Audio Instruction Manual 68P81061E40.

1.2 The first section gives the procedures required to locally operate the station during servicing. This allows service personnel to operate all functions of the station without an operator present at the control site.

1.3 The second section provides a list of routine maintenance procedures that should be performed periodically or whenever the station is serviced. Also, a list of recommended test equipment is provided.

1.4 The last section explains how to disassemble and gain access to the various parts of the station and contains the station mechanical parts identification and station intercabling diagrams. This station is designed for easy service access. Usually, all servicing can be performed with the housing in place on the station by removing only the locking front cover.

2. LOCAL OPERATION

2.1 GENERAL

Once power is applied and the station is properly adjusted, the base or repeater station is normally operated entirely unattended from a remote control point. The station may be manually operated utilizing controls on the control modules in the station chassis. This type of operation may be necessary to accomplish station maintenance and testing. The switch functions are given in Table 1.

WARNING

The transmitter can be keyed remotely. To prevent unexpected transmitter keying while servicing the station, be sure the **LINE DISABLE** switch is actuated (direction of arrow). Also, the TRN5324A Squelch Gate Module must be temporarily removed from the remote control chassis if the station is equipped with any of the following dc transfer modules:

TRN5329A
TRN5240A
TRN5257A

To prevent PA damage, be sure the **LINE DISABLE** switch is actuated and do not locally key the station while having more than one channel element selected.

Table 1. Station Control Module Switch Functions

Switch	Position	Functions Possible
XMIT	Normal (not actuated)	Normal mode of operation
	Actuated (hold to right)	Turns transmitter on with no modulation. Use test microphone connected to Local Mic receptacle to modulate transmitter.
PL DISABLE* (functional only in Private-Line stations or Digital Private-Line)	Normal (left)	Only PL/DPL-coded on-frequency signals accepted by receiver.
	Actuated (right)	All on-frequency signals accepted by receiver.
LINE DISABLE*	Normal (left)	Transmitter can be operated by: 1. XMIT switch 2. Local microphone 3. Remote control console
	Actuated (right)	Transmitter can <i>not</i> be operated by remote control console over control line.

*The DISABLE LIGHT is illuminated when the LINE DISABLE or PL DISABLE switch is actuated.

The following procedures pertain to the local operation of a remotely controlled station or repeater station.

2.2 TRANSMITTER CONTROL

To prevent the transmitter from being keyed remotely, set station control module LINE DISABLE switch in the direction of the arrow. At conclusion of local operation, be sure that the LINE DISABLE switch is returned to its normal position (opposite direction of arrow).

2.3 LOCAL MICROPHONE

Connect a microphone (Motorola Model TMN5064A or equivalent) to the microphone receptacle on the R1 Audio Module. This microphone may be used as a local microphone, and to key the transmitter.

2.4 LOCAL SPEAKER

2.4.1 Stations Without Optional Speaker or Meter and Speaker Box

Connect an 8-ohm, 1-watt test speaker to pins 22 (+) and 23 (-) at the R1 Audio Module edge connector on the station backplane interconnect board. This speaker is used to monitor all received messages.

2.4.2 Stations With Optional Speaker or Meter and Speaker Box

Connect the speaker lead from the speaker box to pins 22 (+) and 23 (-) of the R1 Audio Module edge connector on the station backplane interconnect board. Place the Speaker On-Off switch to the On position. The Speaker On-Off switch is located on the side of the Speaker or Meter and Speaker Box mounted toward the back of the station. The box may be removed from its mounting in the station for access.

2.5. HANDSET

A Motorola handset (Model TMN6057A) may be used to provide local audio, microphone, and transmit push-to-talk. Connect the handset to the microphone receptacle on the R1 Audio Module.

2.6 PORTABLE TEST SET (FOR STATIONS WITHOUT BUILT-IN METERING)

A Motorola S1056-S1059 Series Portable Test Set with TEK-37 or TEK-37A Adapter Cable can be used as a local control facility. Connect the red "control" plug of the adapter cable to the metering receptacle on the unified chassis interconnect board. The speaker in the test set can be used for monitoring received signals and an optional microphone (Model TMN6054A) connected to the microphone receptacle on

the test set can be used for originating transmissions. The XMIT button on the test set can be used to key the transmitter without voice modulation.

2.7 FREQUENCY SELECTION

For stations with a two-frequency transmitter, the frequency can be locally selected by the F1-F2 switch on the dc transfer module or on the F2 tone decoder module. For stations with a two-frequency receiver, frequency selection is made by momentarily operating the REC F1 SELECT or REC F2 SELECT switch on the dc transfer module or on the F2 tone decoder module. For four-frequency stations, the frequency is selected by *momentary* operation of the desired frequency select switch on the four-frequency control module *after* the XMIT switch on the station control module is actuated.

2.8 SELECTION OF OTHER MODES

All other functions that can be activated by remote control can also be activated locally. Each module has test switches to activate any such functions, such as RPTR ON and RPTR OFF. Most of these switches are momentary action, which causes the station to operate in the selected mode as long as the switch is held. The station will return to normal operation when the switch is released.

2.9 RECEIVED AUDIO

After the local speaker is turned on, or connected, the station is ready to receive audio. The receiver PL feature, if used, can be defeated by setting the station control module PL DISABLE switch in the direction of the arrow. (At the conclusion of local operation, be sure that the PL DISABLE switch is returned to its normal position.) If necessary, the receiver can be un-squelched utilizing the receiver SQUELCH control on the receiver chassis. The VOLUME control on the receiver chassis sets the audio output level of the local speaker.

2.10 TRANSMITTING

NOTE

Before initiating any local transmissions, monitor the channel to be sure that it is clear of other transmissions.

The transmitter is locally keyed by either activating the station control module XMIT switch or activating the push-to-talk microphone switch. Voice is transmitted using the local microphone.

2.11 CONCLUDING LOCAL OPERATION

At the conclusion of local operation, perform the following operations and checks to be sure that the station is ready for remote operation.

Step 1. Reset receiver squelch level per procedures in the Receiver Alignment section of this manual.

Step 2. Be sure that station control module switches are positioned for normal operation (reference Table 1).

Step 3. Disconnect microphone and test speaker (if used).

Step 4. Set all external power switches ON.

Step 5. Be sure that station is operable from remote location.

Step 6. Turn local speaker OFF (if applicable).

Step 7. Disconnect or remove any metering plugs or test set.

Step 8. Be sure that the cabinet door is locked.

Step 9. Be sure that vents in cabinet are unobstructed.

3. MAINTENANCE TECHNIQUES

3.1 GENERAL

Specific maintenance procedures for individual chassis, which comprise this station, are contained in the latter paragraphs of this section. Control module maintenance information is provided in the separate Control and Audio manual 68P81061E40. As an aid to isolating a malfunction to a specific chassis or module, a variety of general techniques are appropriate. Refer to Table 2 for routine maintenance checklist.

3.2 TRANSMITTER AND RECEIVER

Most troubles in the transmitter or receiver can be quickly isolated with metering checks. A log of normal meter readings *for this station* should be maintained. Each time maintenance is performed, the meter readings should be entered into the log. Variations from the previous readings can help to isolate a malfunction or may indicate an impending failure. If no previous meter readings are available, typical or minimum meter readings may be found in the receiver, exciter, and power amplifier sections as well as metering procedures.

3.3 POWER SUPPLY

A check of power supply voltages under load and no-load conditions (transmit and standby) should quickly isolate any malfunction.

3.4 REMOTE CONTROL UNIT

Isolation of a malfunction in the control portion of the rf control chassis requires a functional understanding of the overall station operation and the inter-relationship between the various modules and chassis of the station. The Functional Description section along with the Control Modules section of manual 68P81061E40 provide necessary information. With a basic understanding of station operation, troubles may be isolated by analyzing the following questions:

- (1) Can the station be operated locally but not remotely? If so, this eliminates many circuits as possible sources of trouble.

Table 2. Routine Maintenance Checklist

Item	Check
Receiver	Measure the signal level required to obtain 20 dB quieting.
	Compare meter readings with the minimum value and all previous readings taken. Realign the receiver, if necessary.
	For PL stations, check for proper operation of the PL decoder. Does the squelch open when the proper PL tone or binary code is detected?
	Verify receiver frequency, adjust if necessary.
Transmitter	Measure transmitter output power.
	Compare meter readings with the minimum value and all previous readings taken. Realign the transmitter, if necessary.
	Verify that each transmitter channel is on frequency and adjust if necessary.
	Tune and load the transmitter to the antenna.
	Measure transmitter frequency deviation for both voice and PL coded modulation. Adjust the "IDC" control, if necessary.
System Operation	Measure the exciter modulator sensitivity.
	Measure and adjust the audio input to the exciter.
	Measure and adjust the receiver(s) audio output to the control line.
	Check control line levels and functions for proper operation.
	Adjust receiver(s) on frequency with the distant transmitter(s) in the system.
After Performing Maintenance	Check for proper repeater operation on repeater models.
	Check all accessory equipment for proper operation.
	Check all items listed in the <i>Concluding Local Operation</i> paragraph of this section of the instruction manual.

(2) How many modes are inoperable? Concentrate testing on circuits that are common to the inoperable modes.

(4) Are jumpers properly installed? The many jumpers in this station provide vast flexibility, but could be a source of trouble if improperly added, removed, or not removed, as the case may be.

(3) Are adjustments properly set? This includes audio level adjustments at the station *and at the remote control point*.

4. RECOMMENDED TEST EQUIPMENT

A list of recommended test equipment for maintenance of this station is given in Table 3.

Table 3. Recommended Test Equipment

Type of Equipment or Type of Measurement	Equipment Characteristics	Recommended Type
Transmitter Frequency Measurement	Frequency — 100-200 MHz Accuracy — $\pm .00005\%$ or better	Any of the following items of Motorola Test Equipment: Model R1200 Series Service Monitor Model S1344 Series Frequency Counter & Deviation Meter Model R1025 Series Frequency Counter
Transmitter Deviation Measurement (Note 1)	Peak reading type for voice or sinusoidal wave; scales for accurate reading of ± 5 kHz deviation (and ± 1 kHz deviation for Private Line models)	Any of the following items of Motorola Test Equipment: Model R1200 Series Service Monitor Model S1344 Series Frequency Counter & Deviation Meter Model R2001 Series System Analyzer
Transmitter Power Output Measurement	100-200 MHz; 50 ohms: at least 0-125 watts. 50 ohms dummy load: at least 125 watts.	Motorola S1350 Series Wattmeter with appropriate element Motorola Model R2001 Series System Analyzer Motorola Model T1013 Series RF Load Resistor
RF Signal Generator for receiver testing (Note 2)	100-200 MHz; FM; high-stability ($\pm .0002\%$ or better); adjustable output 0 to 1000 microvolts	Motorola Model R1200 Series Service Monitor Motorola Model R2001 Series System Analyzer Motorola Model R1201 Series AM-FM Signal Generator Motorola Model R1020 Signal Generator
Audio Voltage Measurements	High impedance (10 megohm); dBm scale	Motorola Model S1053 Series Solid State AC Voltmeter
Audio Signal Generator for audio circuit testing in receiver and transmitter	Variable amplitude 0 to 1 volt; 1 kHz tone (300 to 3000 Hz preferred); sinusoidal wave	Motorola Model S1067 Series Solid State Audio Oscillator Motorola Model TEK-1 Tone Oscillator Motorola Model R1200 Series Service Monitor
DC Voltage Measurements, Resistance Measurements, RF Voltage Measurements	High impedance (11 megohm) DC multimeter	Motorola S1063 Series Solid State DC Multimeter with SLN6055A RF Probe Motorola Model R1001 Series Digital Multimeter Motorola R1024 Solid State DC Multimeter with RTL4103 R.F. Probe
Waveform Measurements	Oscilloscope:	Motorola Model R1029 Dual Trace Oscilloscope Audio Circuit Measurements: Motorola Model R1004 Series Oscilloscope RF Circuit Measurements: A very high quality instrument is required (at least 50 MHz bandwidth)
Tone <i>Private-Line</i> injection for PL decoder circuit measurements	<i>Private-Line</i> tone generator using <i>Vibrasender</i> resonant reed for frequency accuracy; or audio oscillator with frequency counter for accurate setting of oscillator.	Motorola Model S1333 Series Audio Synthesizer Motorola Model SLN6221 Series <i>Private-Line</i> Tone Generator
Digital <i>Private-Line</i> Encoder and Decoder measurements	Digital <i>Private-Line</i> Encoder and Decoder. Also test digital code plugs.	Motorola Model R1100 Series Code Synthesizer
Tuning Tool	Used for adjusting all tunable components during equipment alignment.	Motorola Part No. 66-83398A01 & 66-82977K01
Contact Removal Tool	Used to remove female wire terminals from metering cable connector	Motorola Part No. 66-84690C01

5. DISASSEMBLY AND SERVICE ACCESS

5.1 FRONT COVER AND LINE FUSE

5.1.1 Access to all circuitry on the *MSR 2000* station is gained through the front of the station. To remove the front door, turn the lock to the left with the key provided with the station. Pull the door panel back, and lift it up slightly to disengage the mounting flanges at the bottom.

5.1.2 The ac line fuse is located on the front side of the junction box at the right-hand side of the cabinet (refer to Figures 1 and 3). To replace the fuse, disconnect the line cord from the junction box. Unscrew the fuseholder cover from the fuseholder with a screwdriver.

5.2 POWER AMPLIFIER ACCESS AND REMOVAL

5.2.1 Access to Intermittent Duty Power Amplifier

5.2.1.1 To gain access to the power control board for servicing and metering, remove the 5 screws holding the cover over the power control board area of the PA casting (refer to Figure 1).

5.2.1.2 To gain access to the power amplifier board for servicing, remove the two black power amplifier securing screws. Swing the PA chassis assembly out and down (it is hinged at the bottom). Loosen 4 captive screws holding the cover over the power amplifier board (refer to Figure 2).

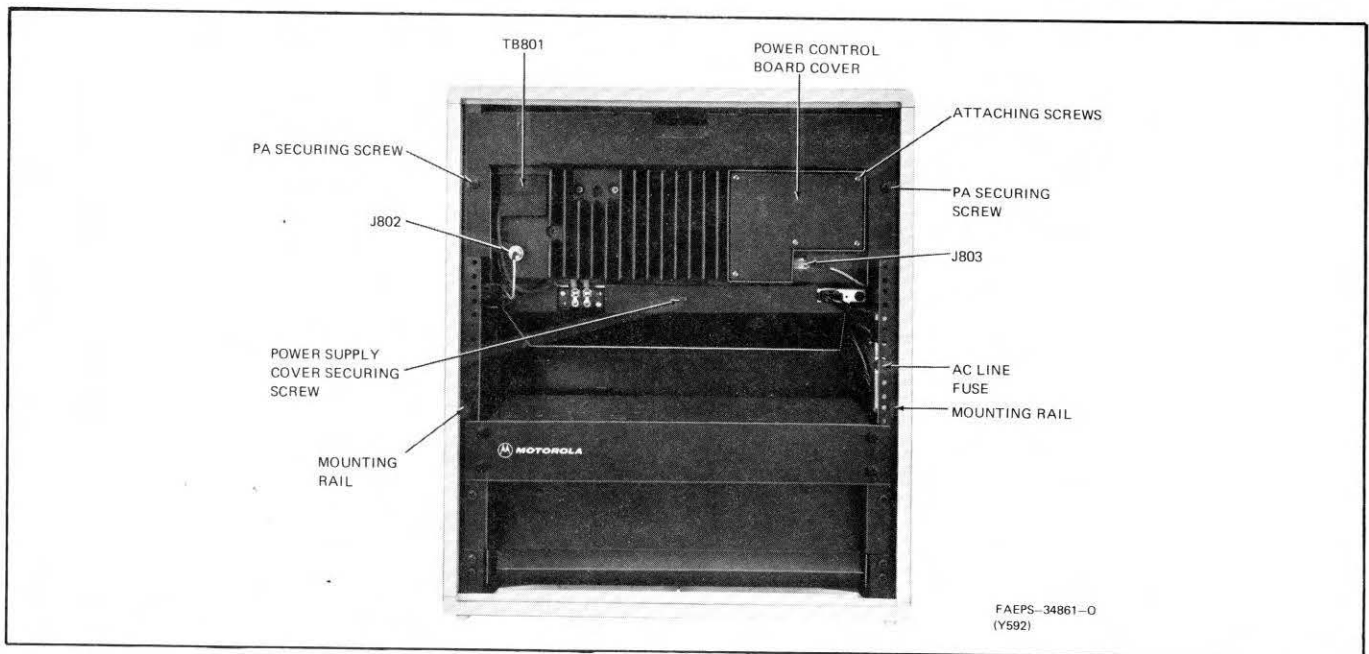

Figure 1. PA and Power Supply Detail of Intermittent Duty Station

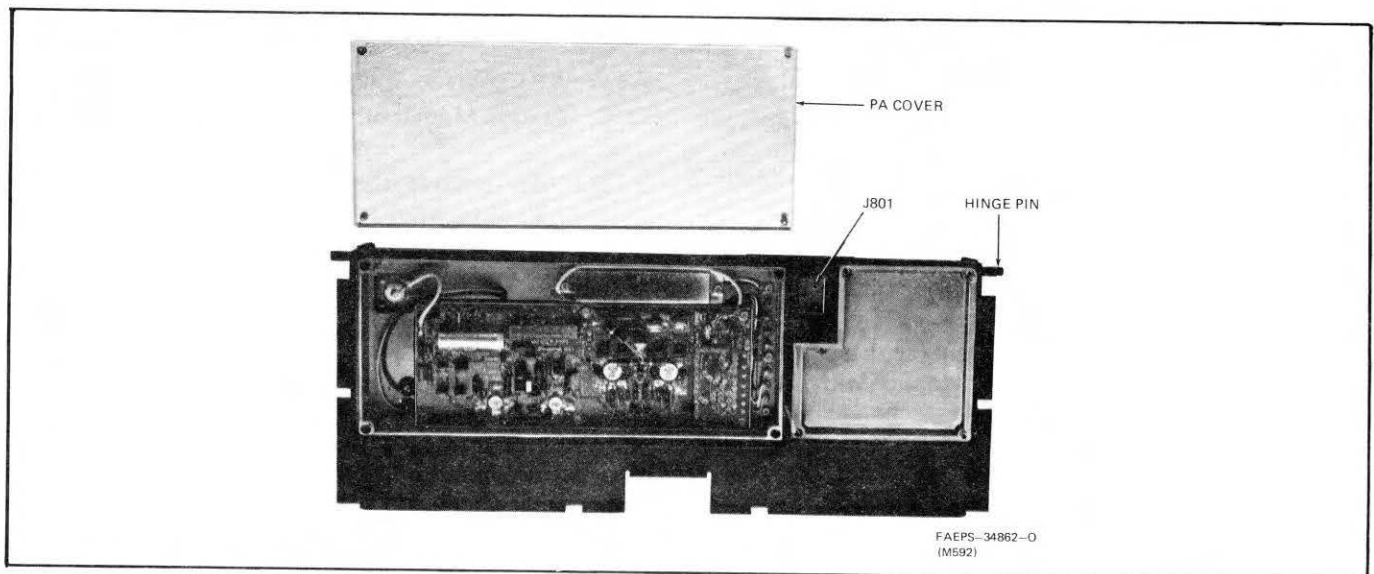

Figure 2. Power Amplifier Detail of Intermittent Duty Station

5.2.2 Access to Continuous Duty Power Amplifier

5.2.2.1 To gain access to the power amplifier boards for servicing and metering, remove the 4 black power amplifier securing screws. Swing the PA chassis assembly out and down (it is hinged at the bottom). Metering is accessible without removing any covers. Remove 12 screws holding the cover over the PA and power control board for servicing the PA (refer to Figures 3 and 4).

5.2.2.2 To gain access to the power control board for servicing, remove the 4 screws holding the power control bracket (refer to Figure 4).

5.2.3 Removal of Power Amplifier

The entire power amplifier chassis may be removed, if desired, for substitution or for access to the power supply. Perform the following steps:

Step 1. Disconnect the two coaxial connectors from J802 and J803 on the PA chassis. Disconnect the two power wires (red and black) from TB601 at the power supply.

Step 2. Swing the power amplifier chassis into the down position as explained above. Disconnect P801, the three-wire connector, from J801 on the PA chassis.

Step 3. With both hands under the PA chassis, lift the chassis approximately 1/2-inch and pull it toward you. Raise the left side of the PA chassis until the hinge pins clear the mounting rails, and pull the PA chassis out of the station cabinet.

Step 4. Installation is the reverse of the above.

5.3 RF CONTROL CHASSIS ACCESS AND REMOVAL (Refer to Figures 1 and 3.)

5.3.1 The rf control chassis may be opened or lowered for service access. The control module cover panel must be removed for access to control and audio modules, and the chassis may tilted out for access to the back of the backplane interconnect board and the rf boards.

5.3.2 To remove the control module cover panel, pull outward on the lip at the top of the panel. The panel snaps and pivots outward. The control and audio modules may be removed for servicing with a Motorola part no. 66-83574F01 Card Puller, supplied with the station.

5.3.3 To tilt out the rf control chassis, remove two black Phillips head screws securing the rf control chassis in place. Pull the chassis out from the top and tilt downward. In this position, all exciter and receiver

metering connections are accessible, and the backplane interconnect board may be serviced.

5.3.4 To remove the rf control chassis, tilt out the chassis to the service position and perform the following steps:

Step 1. Mark and disconnect all wiring from the terminal screws on the backplane interconnect board.

Step 2. Remove two screws securing each rf coaxial connector to the exciter and receiver positions.

Step 3. Disconnect main wiring harness connector P1 from J1 on the backplane interconnect board.

Step 4. Cut all wire ties and remove any cable clamps securing cables to the rf-control chassis.

Step 5. Lift up the rf control chassis approximately 1/2 inch and pull toward you. Raise the left-hand end of the chassis until the hinge pins clear the mounting rails, and pull the chassis out of the station housing.

Step 6. Installation is the reverse of the above. Be sure to replace all wire ties and cable clamps in the position originally supplied.

5.4 EXCITER AND RECEIVER ACCESS AND REMOVAL

5.4.1 RF Cover — Base Station Models

To remove the rf cover to gain access to the exciter and receiver circuit boards, remove 4 Phillips head screws (with plastic covers) as shown in Figure 5. Slide the cover out slightly and lift up while pulling toward you. Pull the cover out of the station cabinet. Tilt out the rf control chassis as explained in paragraph 5.3 for easy access to the exciter and receiver circuit boards. The exciter and receiver circuit boards may be removed by pulling the ejector handles and then pulling the boards out of the chassis.

5.4.2 RF Covers — Fully Optionable Repeater Station Models or Stations With Shield Option

5.4.2.1 To remove the front rf cover, remove 4 Phillips head screws (with plastic covers) as shown in Figures 6 and 7. The exciter and receiver boards may now be removed by pulling the ejector handles and then pulling the boards out of the chassis.

5.4.2.2 To remove the top rf cover (front rf cover must be removed first), remove two black Phillips head screws securing the rf control chassis in place. Tilt the chassis out from the top by pulling toward you. Loosen 15 hex-head screws holding the cover in place, and slide the cover down so that the large end of the keyhole slots clear the securing screws. Lift the panel away from the chassis.

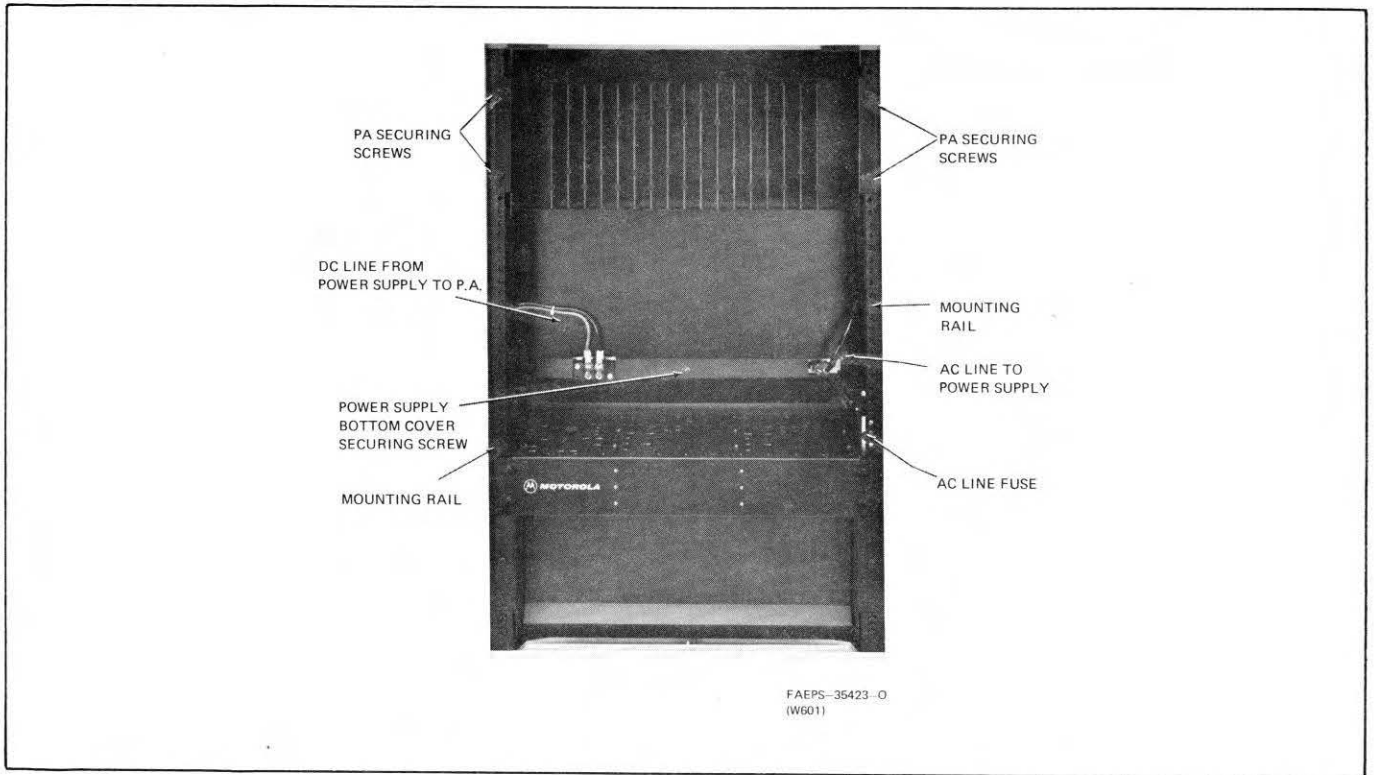

Figure 3. PA and Power Supply Detail of Continuous Duty Station

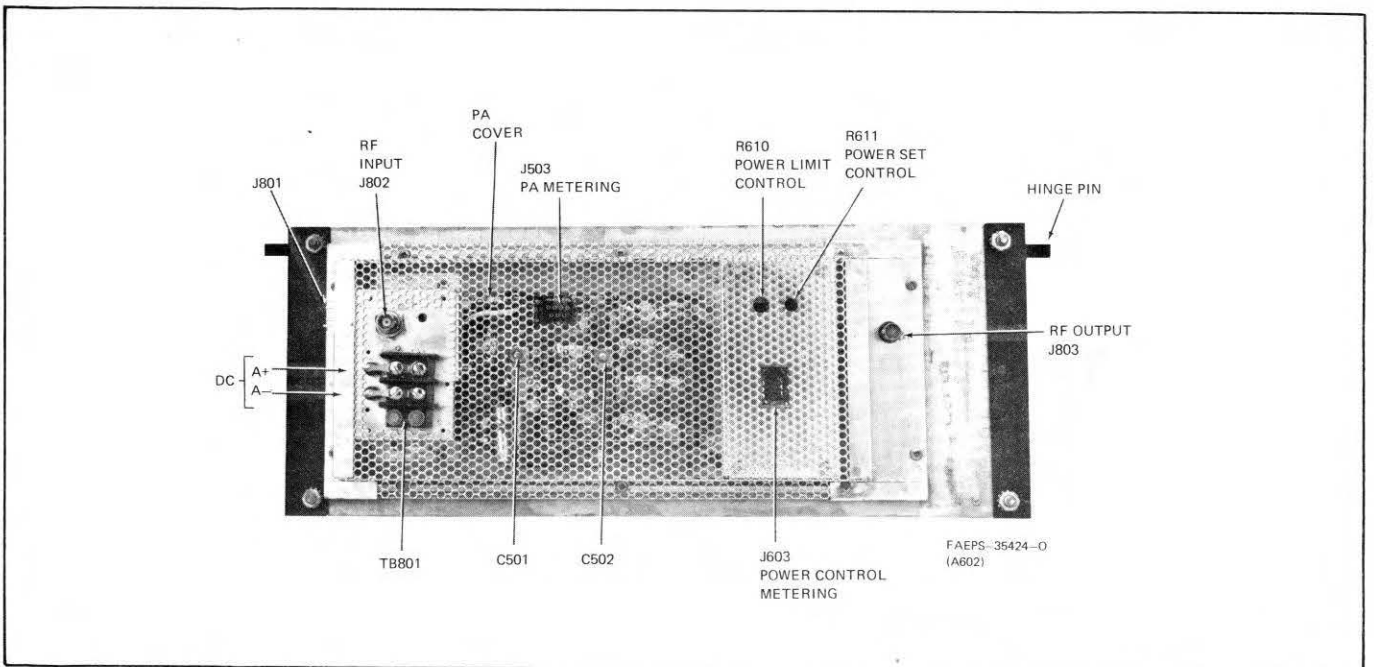

Figure 4. Power Amplifier Detail of Continuous Duty Station

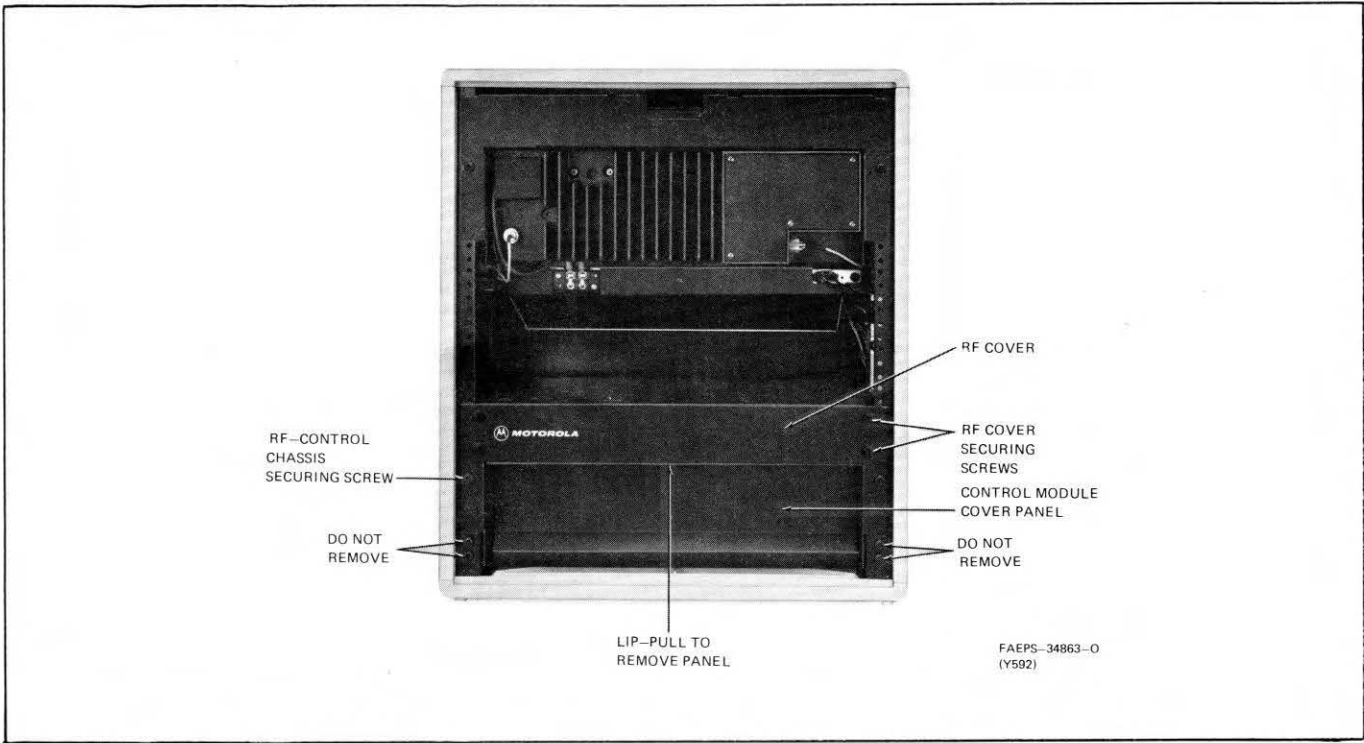

Figure 5. Basic Intermittent Duty Station Chassis Access

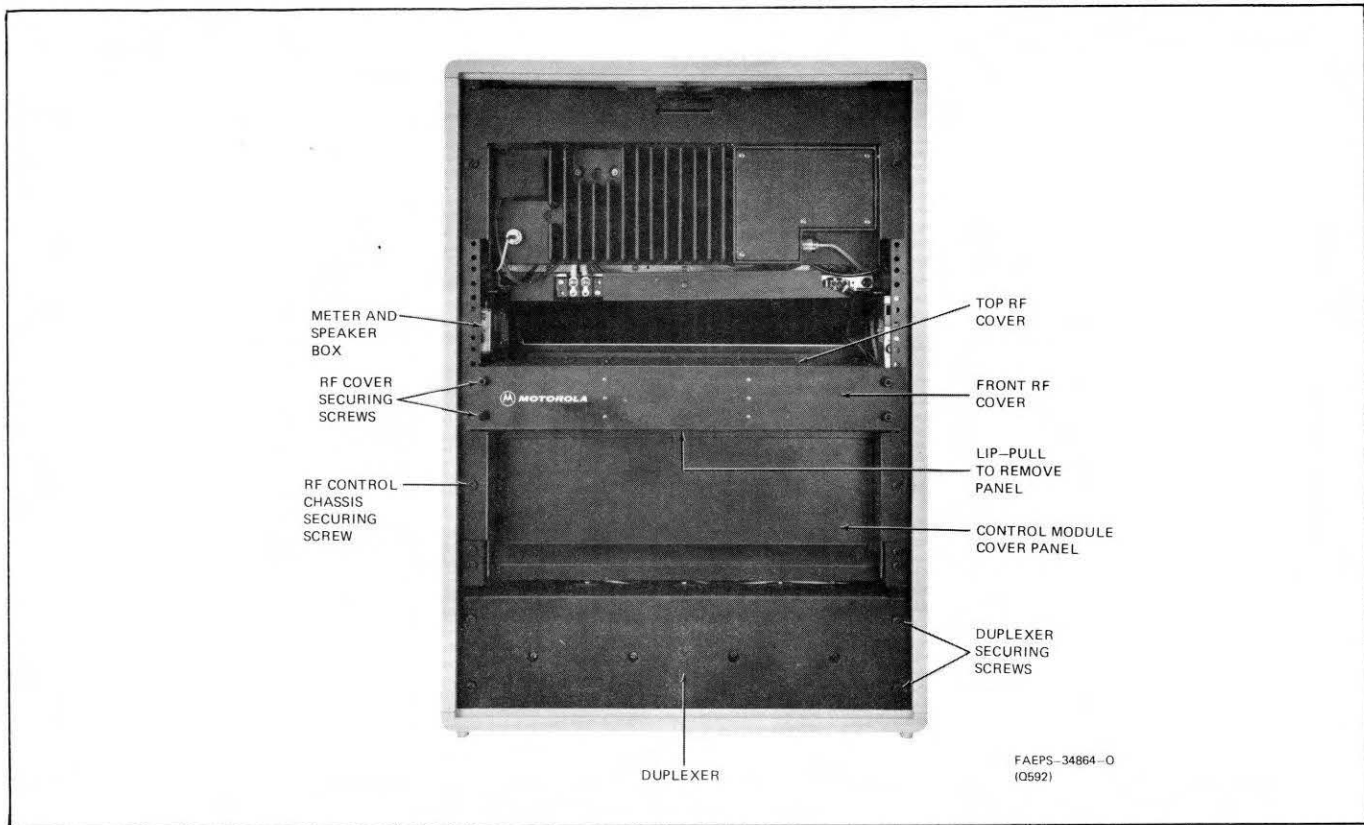

Figure 6. Fully Optionable Intermittent Duty Station Chassis Access

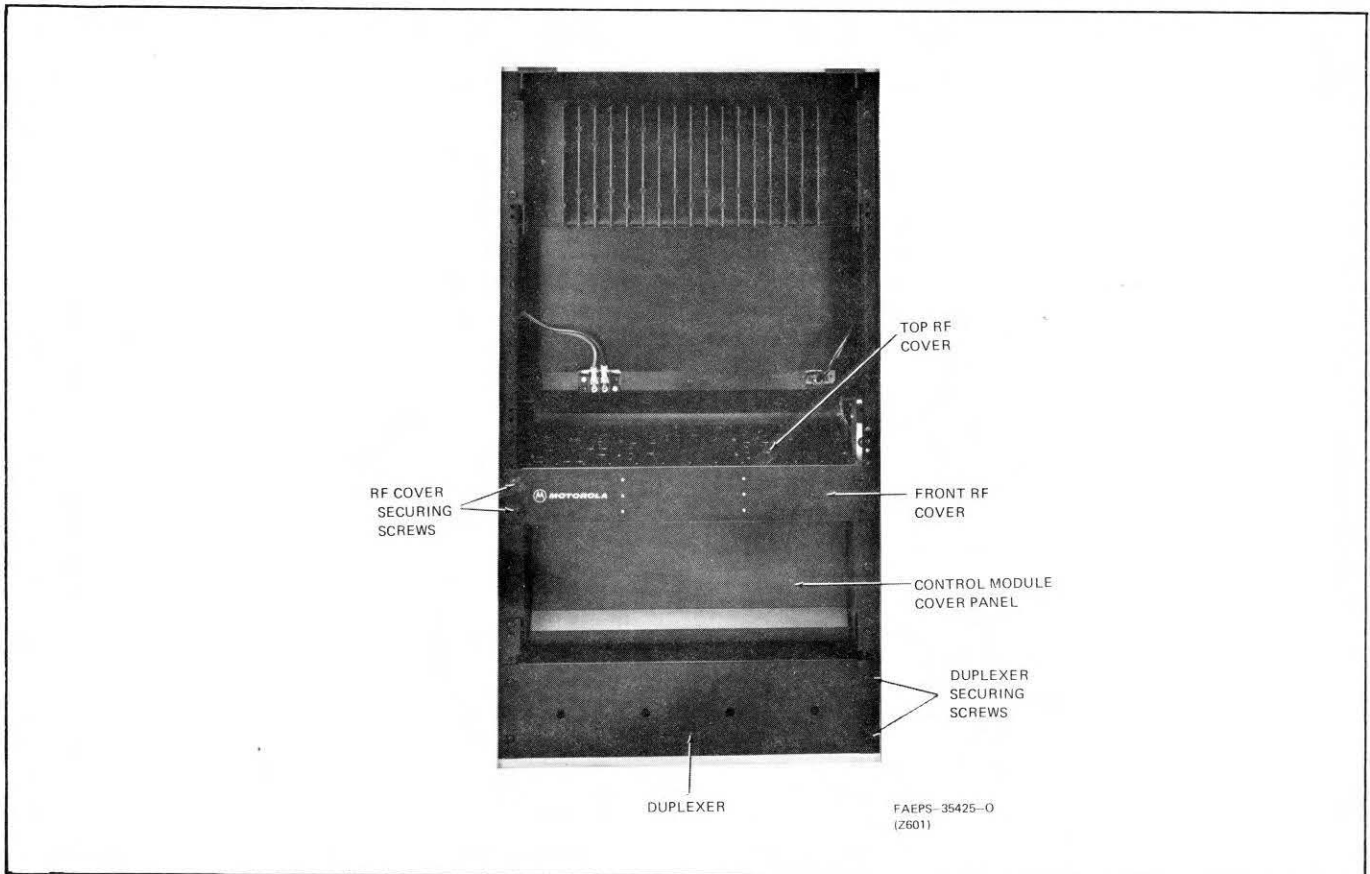

Figure 7. Fully Optionable Continuous Duty Station Chassis Access

5.5 SPEAKER INTERCOM WITH SPEAKER AND DC METERING CHASSIS ACCESS

Instructions for use of the station service accessory boxes are given in the Accessories section of this manual. The service box is mounted to the left side mounting rails of the station, inside the station housing. For ease in servicing, the box may be removed from the station cabinet. Lift the box up to clear the keyhole slots in the mounting brackets, and slide the box out of the cabinet. When finished, replace the box into the station cabinet. It is not necessary to tighten the mounting screws, once the station is permanently installed.

5.6 DUPLEXER REMOVAL

Instructions for servicing and adjusting the duplexer are provided in the Duplexer instruction section in this manual. To remove the duplexer from the MSR 2000 station cabinet, remove four black Phillips-head screws securing the duplexer to the mounting rails. Pull the duplexer partially out of the cabinet, until the rf connectors are accessible. Disconnect three UHF-type connectors, and remove the duplexer from the station cabinet. Installation is the reverse of this procedure.

5.7 POWER SUPPLY ACCESS

5.7.1 The power supply may usually be serviced without removing it from the cabinet. If removal is necessary, refer to the Power Supply instruction section of this manual for the recommended removal procedure.

5.7.2 To gain access to the power supply chassis, remove the power supply cover plate located under the PA chassis. It is retained by a single screw in the upper center of the cover (refer to Figures 1 and 3). For continuous duty stations, remove the top power supply cover plate located directly behind the PA chassis. It is retained by two screws located in the lower left and right hand corners. It may also be necessary to remove the PA chassis from the station housing, refer to the Power Amplifier Removal and Access paragraph in this section.

5.8 TWO-RECEIVER COUPLER REMOVAL

The two-receiver coupler is located along the left-hand side of the station housing, and is accessible only with the rf control chassis removed from the station housing. Refer to the RF Control Chassis Access and

Removal paragraph for the correct procedure. To remove the two-receiver coupler from the station housing, remove 2 screws securing it to the mounting rails. Lift the two-receiver coupler away from the mounting rails and disconnect the 3 phono-type rf connectors from the coupler plate.

5.9 JUNCTION BOX ACCESS

The back side of the junction box (TRN5350A or TRN5351A) can be reached by removing only the locking station cover. The line cord connection panel may be removed from the outside of the station housing by removing 2 screws holding the panel in place. To remove the entire junction box assembly from the station, remove the station wraparound cover following the procedure in the Wraparound Cover Removal paragraph. Remove 4 screws holding the junction box to the mounting rails.

5.10 WRAPAROUND COVER REMOVAL

The station wraparound cover is secured in place by the top and bottom covers of the station. To remove the station wraparound cover, perform the following steps:

Step 1. Remove six TORX® -type (T45) screws holding the top cover in place, using a Motorola part number 66-84071N02 TORX® wrench (supplied with station). Remove the top cover.

Step 2. Lift the wraparound cover approximately 1/2-inch up and out of the bottom cover channel.

Step 3. Spread the sides of the wraparound cover enough to clear the mounting rails of the station housing, and slide the housing toward the back of the station and remove.

Step 4. Installation is the reverse of the above.

6. MECHANICAL PARTS IDENTIFICATION

The mechanical parts identification photos are used to identify certain mechanical parts that are not identified elsewhere in the manual.

TORX® is a registered trademark of Camcar Division of Textron Inc.

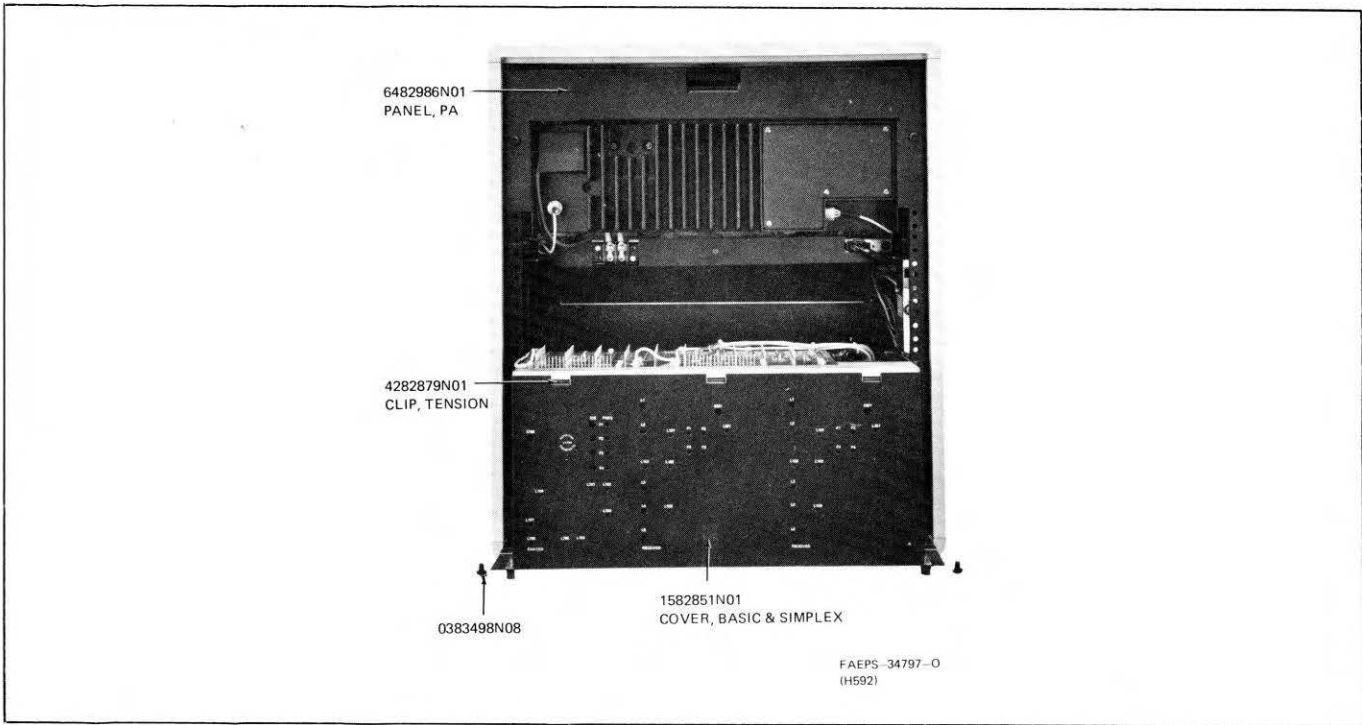
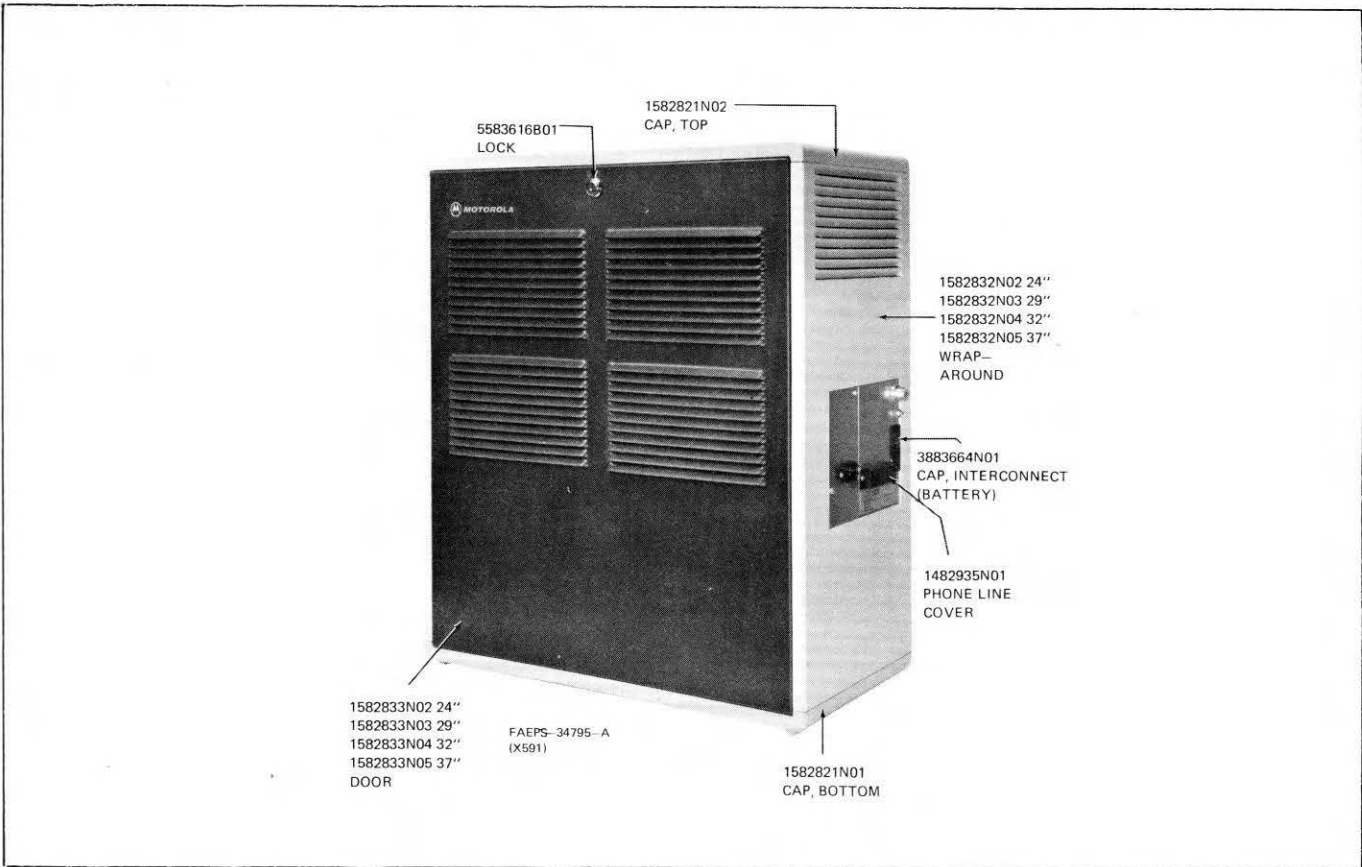

*MSR 2000 Basic Model Station
Mechanical Parts Identification
Motorola No. PEPS-34951-A
(Sheet 1 of 4)
11/15/82 - V & G*

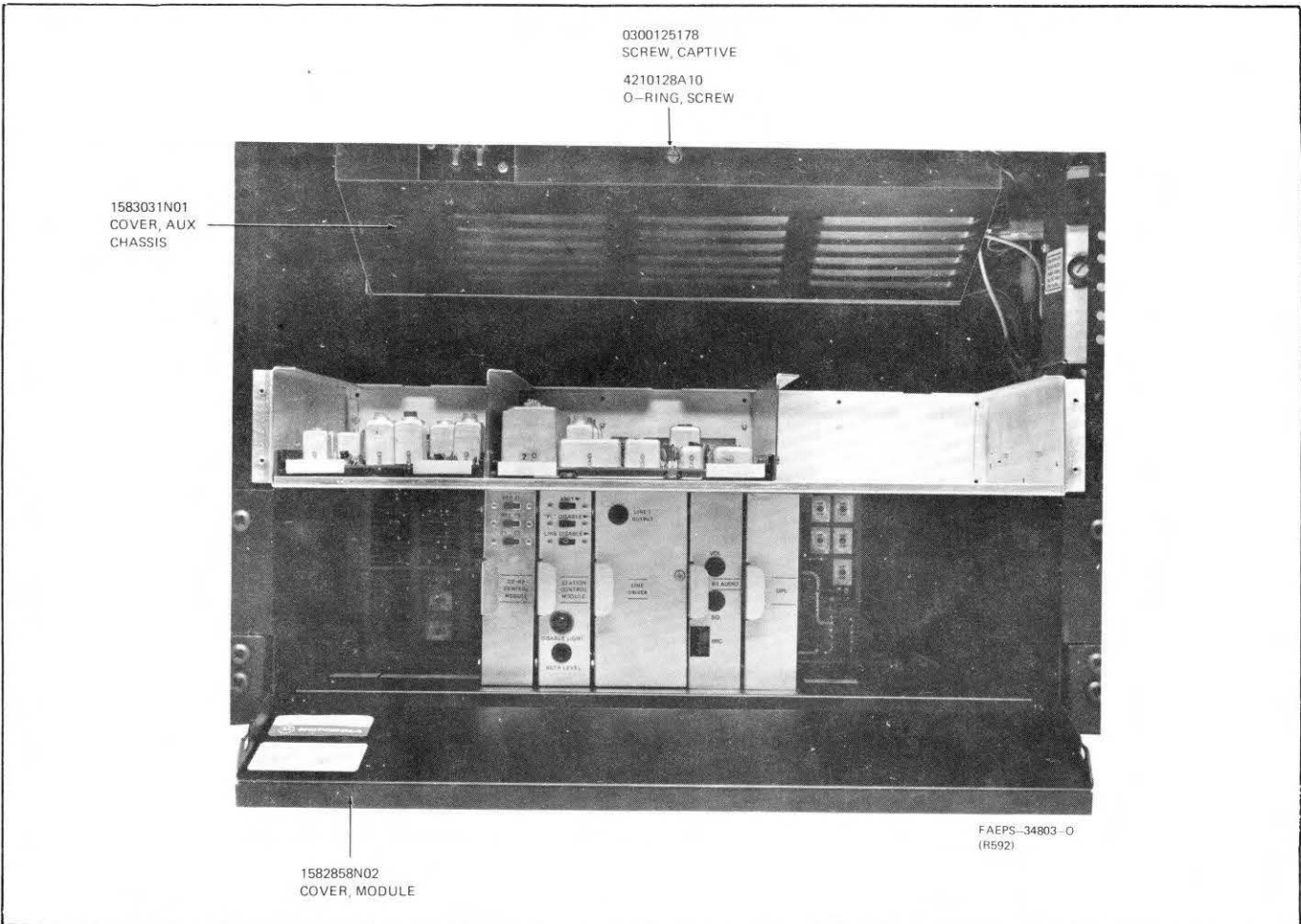
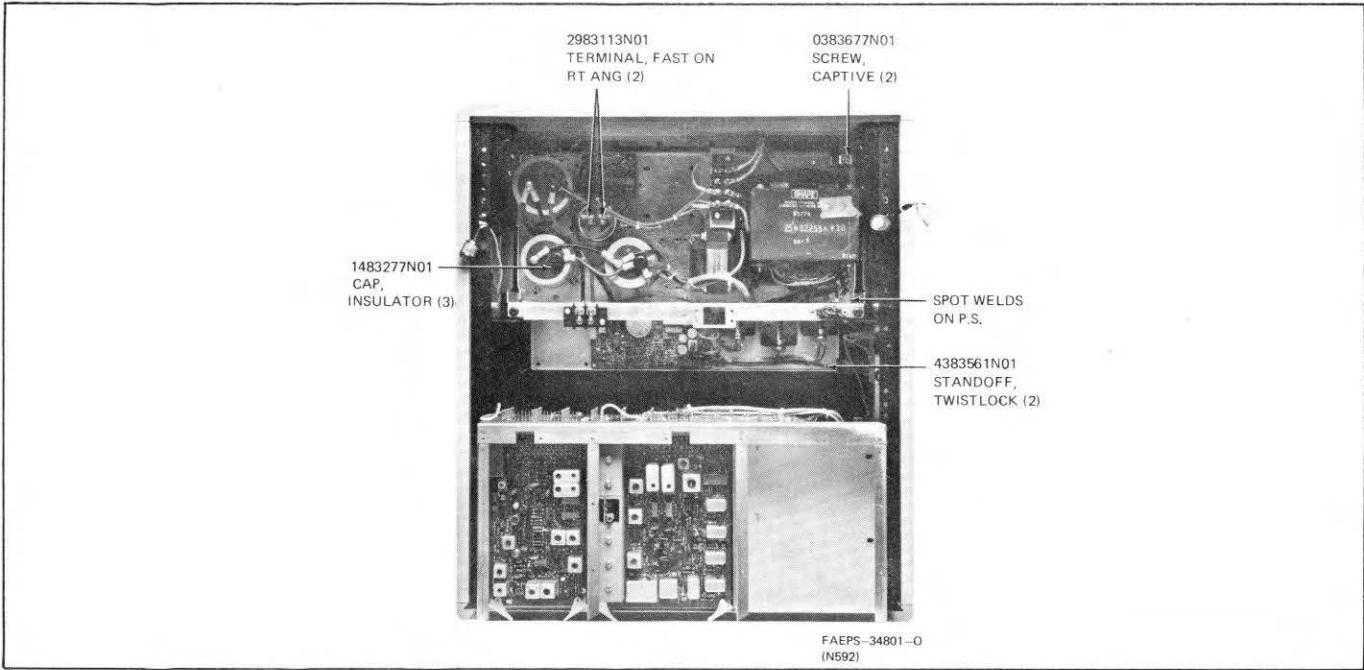

MSR 2000 Basic Model Station
Mechanical Parts Identification
 Motorola No. **PEPS-34951-A**
 (Sheet 2 of 4)
 11/15/82 - V & G

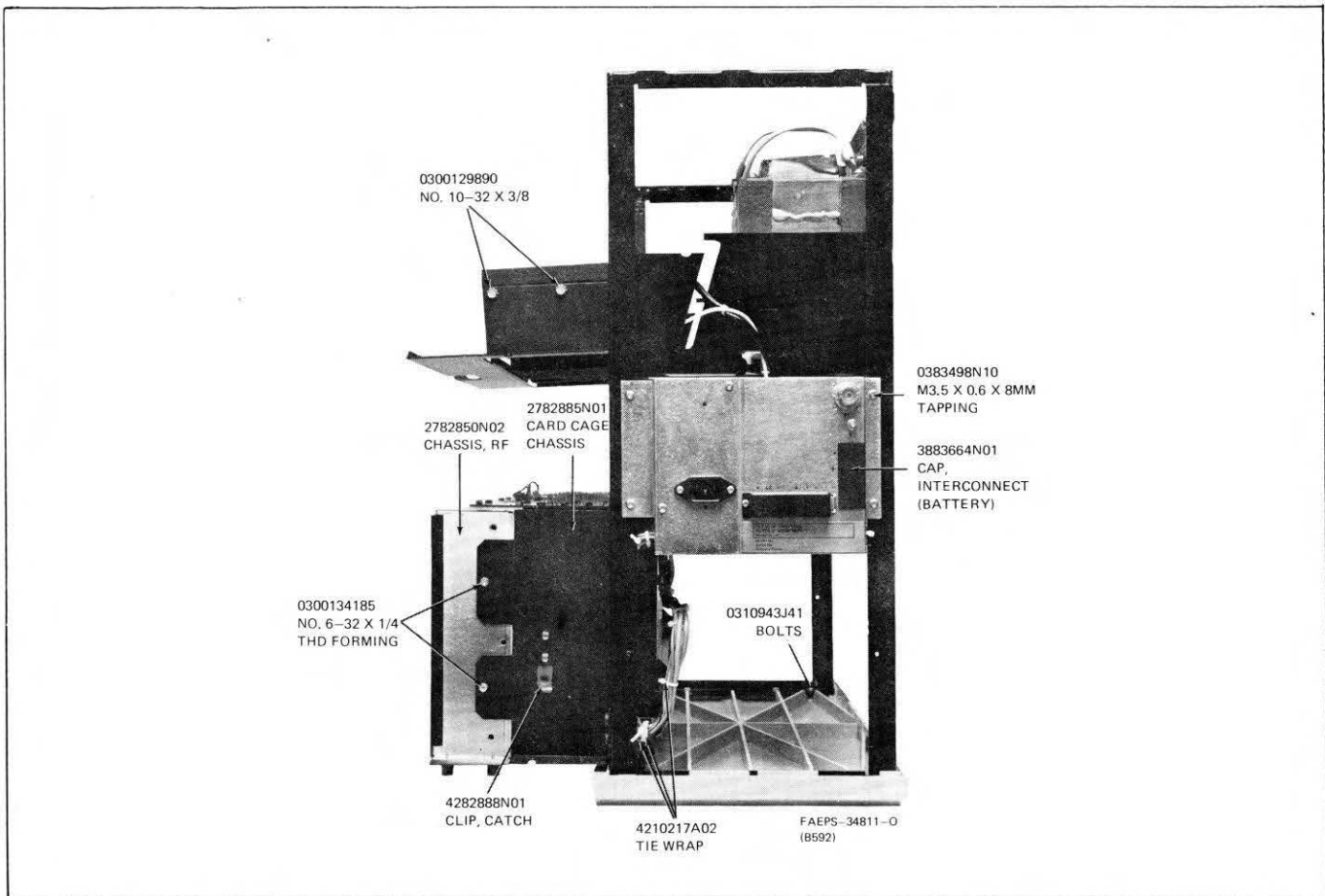
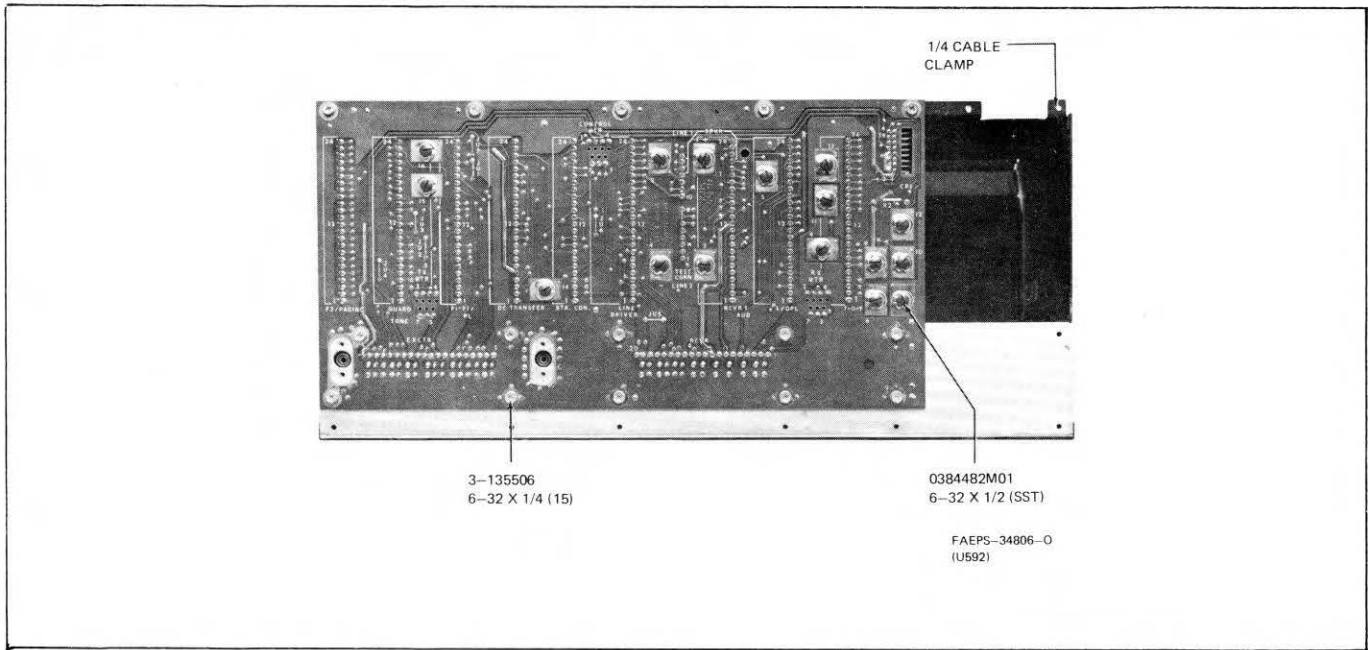

STATION MAINTENANCE

*MSR 2000 Basic Model Station
Mechanical Parts Identification
Motorola No. PEPS-34951-A
(Sheet 3 of 4)
11/15/82 - V & G*

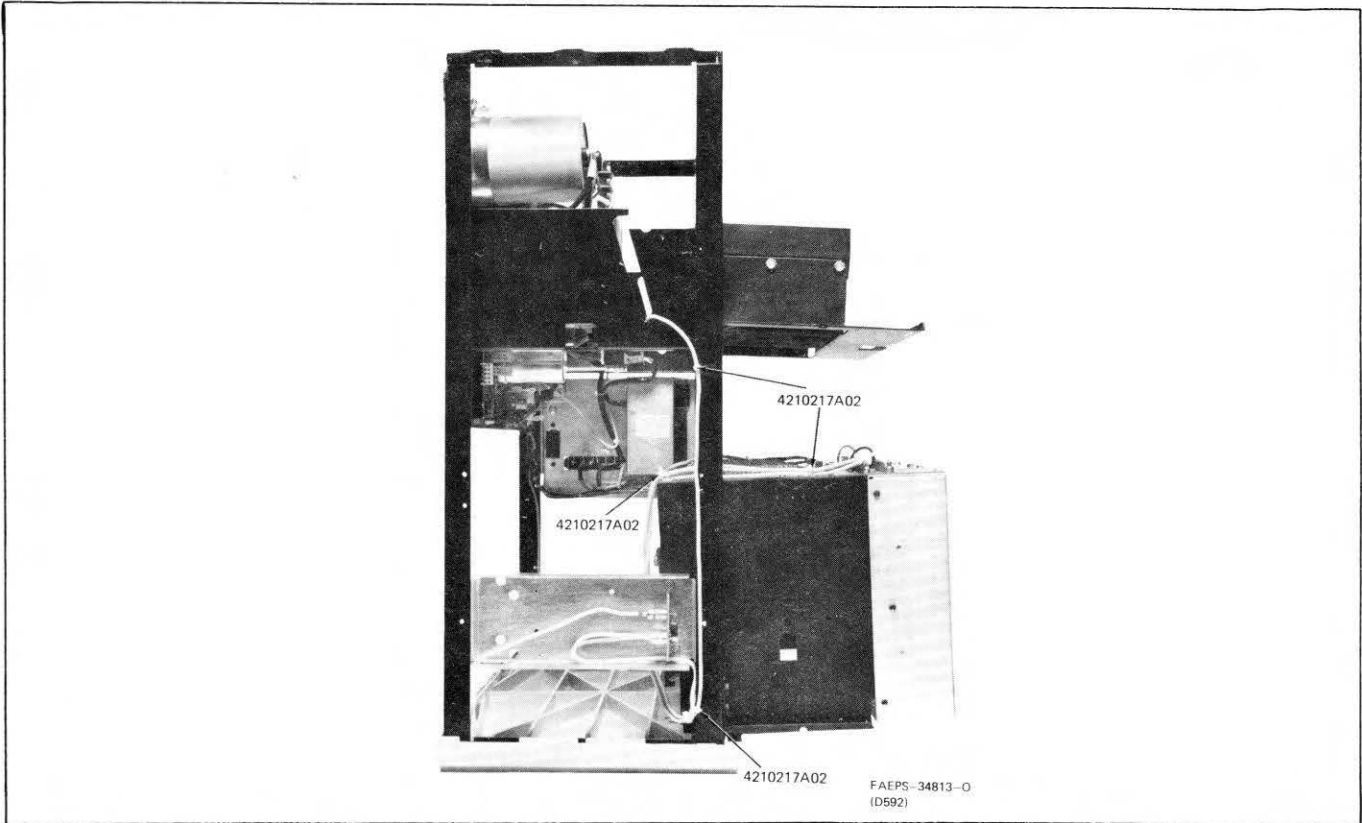
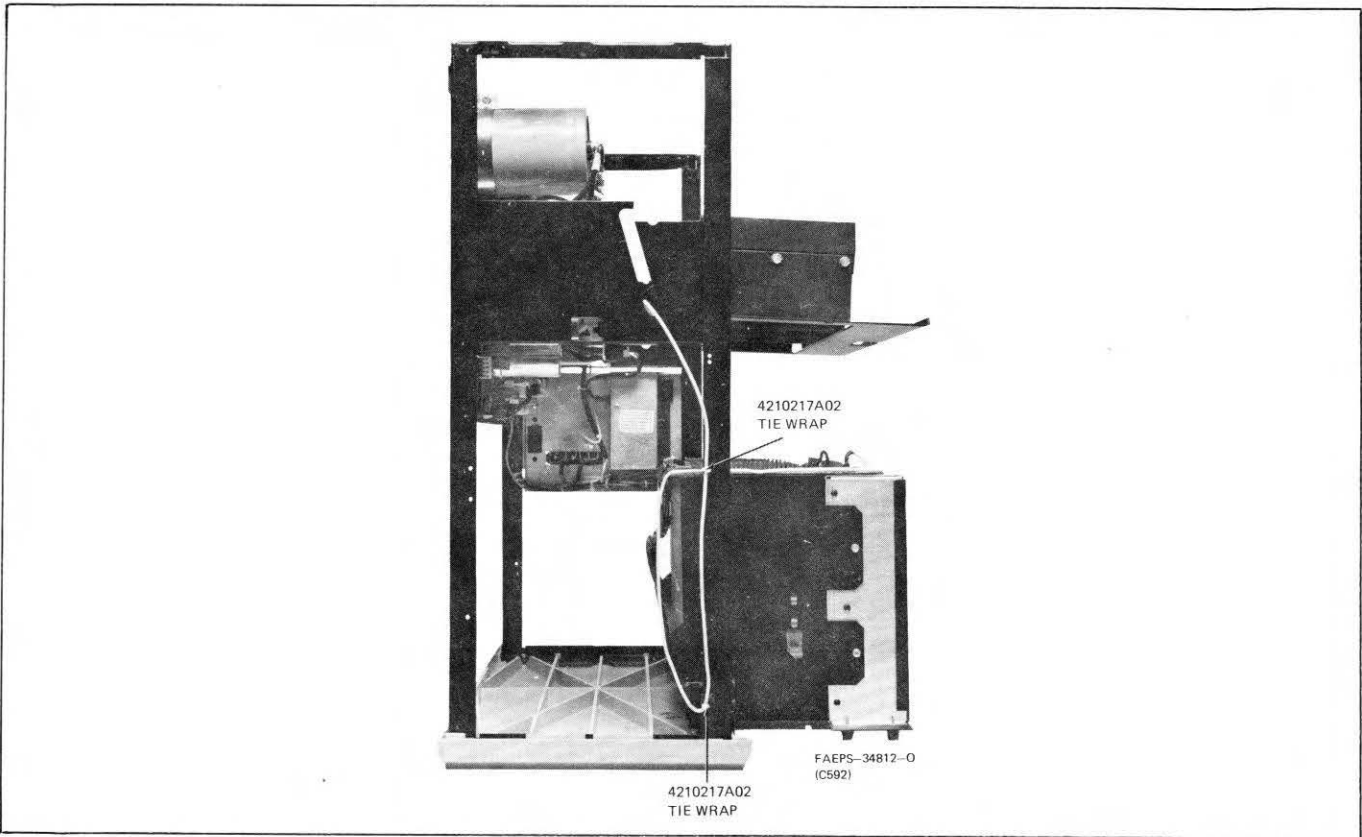

MSR 2000 Basic Model Station
 Mechanical Parts Identification
 Motorola No. PEPS-34951-A
 (Sheet 4 of 4)
 11/15/82 - V & G

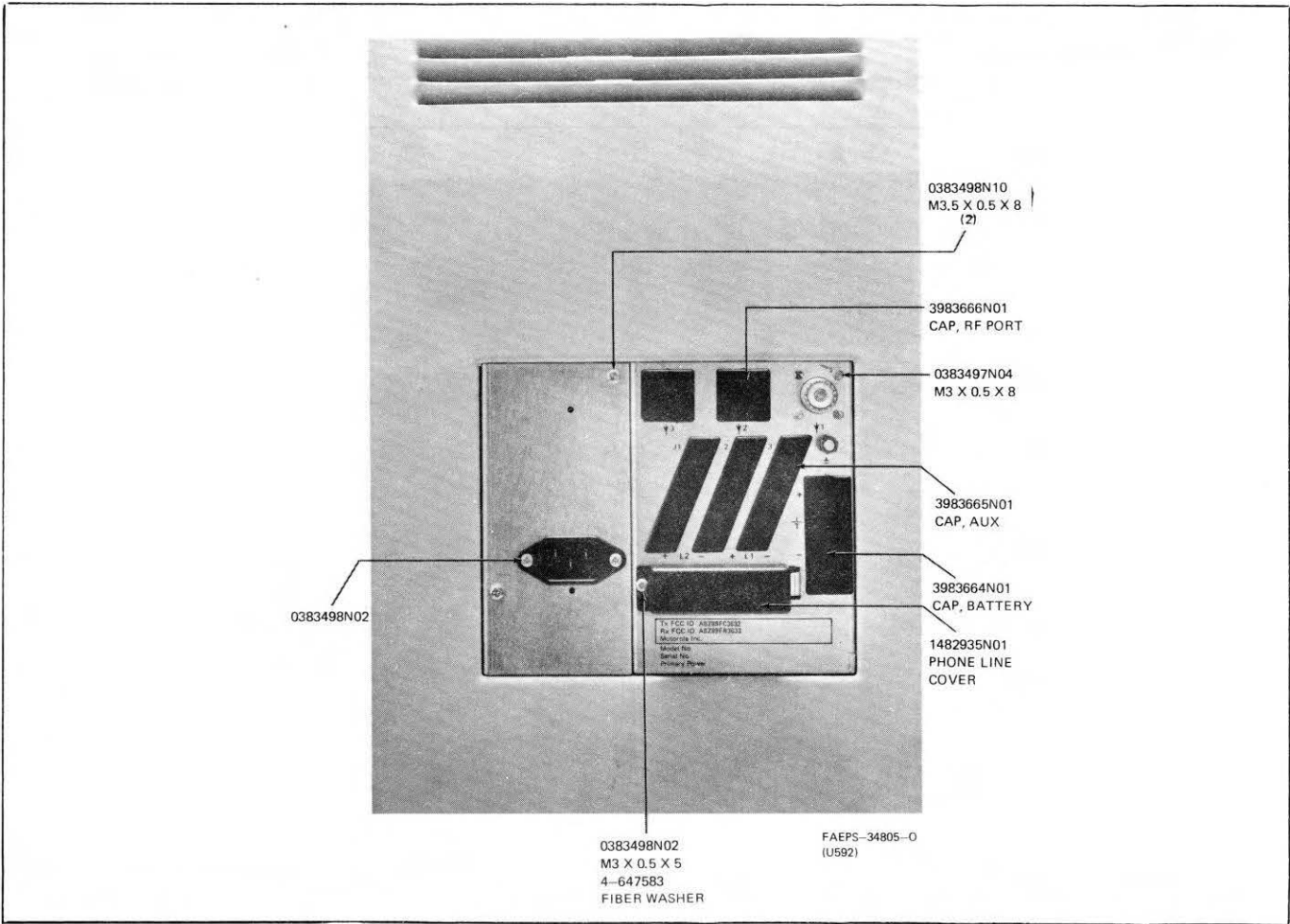
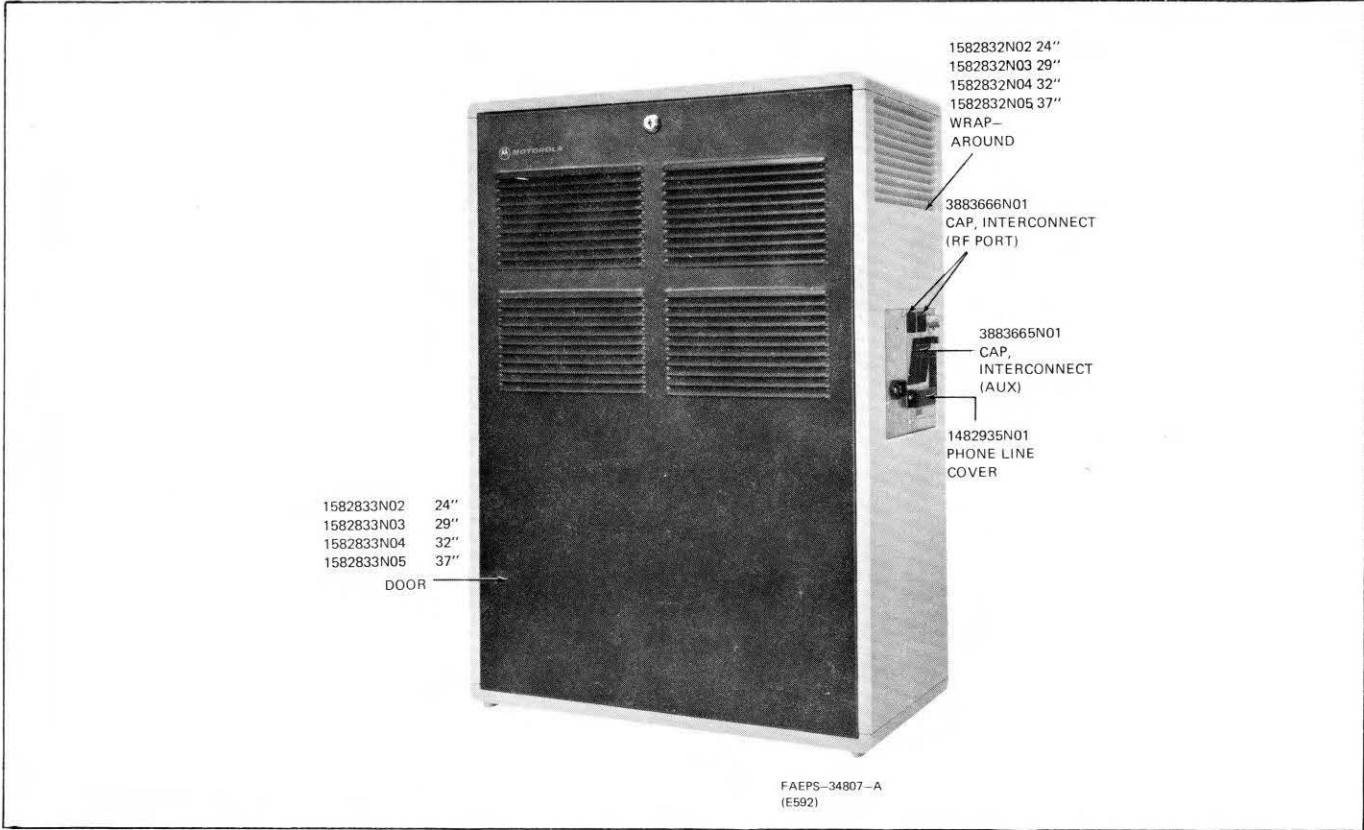

STATION MAINTENANCE

*MSR 2000 Fully Optionable Model Station
 Mechanical Parts Identification
 Motorola No. PEPS-34952-A
 (Sheet 1 of 4)
 11/15/82 - V & G*

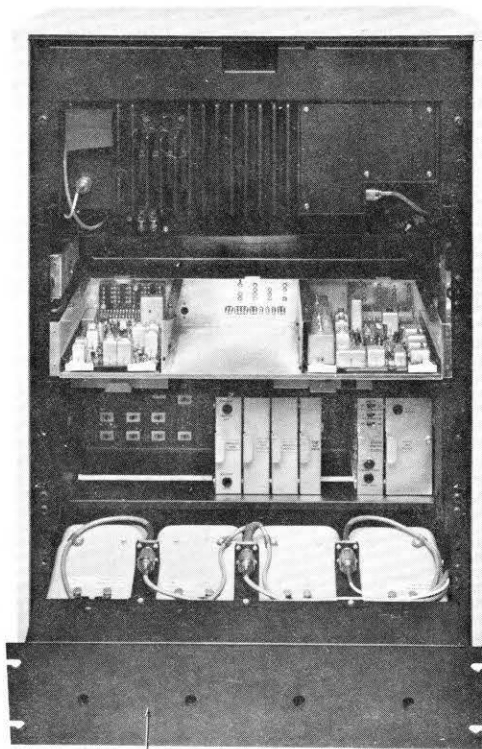

2782934N01
CHASSIS,
DUPLXER

FAEPS-34798-O
(I592)

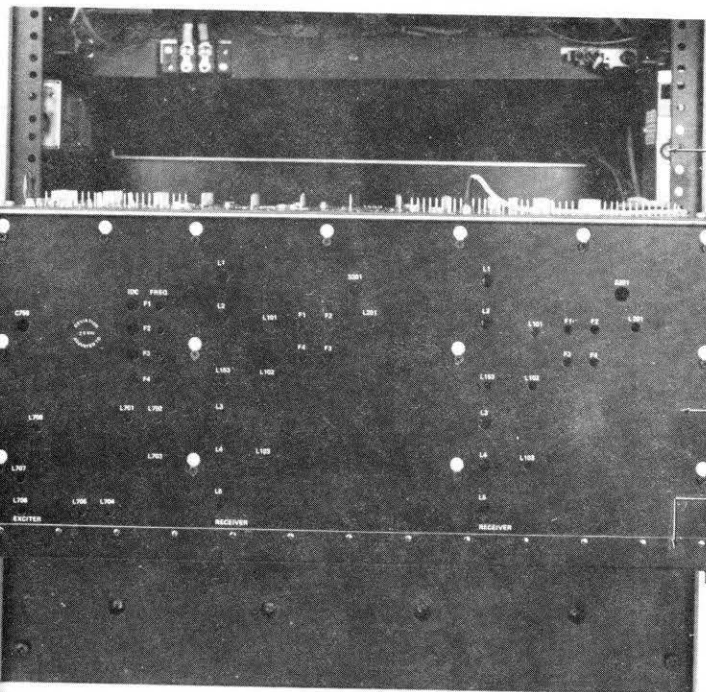

1582891N01
FUSE HOLDER
& NUT
3882892N01
FUSE HOLDER CAP

0300136932
NO. 4-40 X 3/8
PHL HEX (15)

1582852N01
COVER, TOP

1582853N01
COVER,
FRONT

4283123F01 (4)
PLASTIC RETAINER
0583124F01 (4)
EYELET NO. 6
0300138430 (4)
NO. 4-24 X 3/8

FAEPS-34799-O
(K592)

MSR 2000 Fully Optionable Model Station
Mechanical Parts Identification
Motorola No. PEPS-34952-A
(Sheet 2 of 4)
11/15/82 - V & G

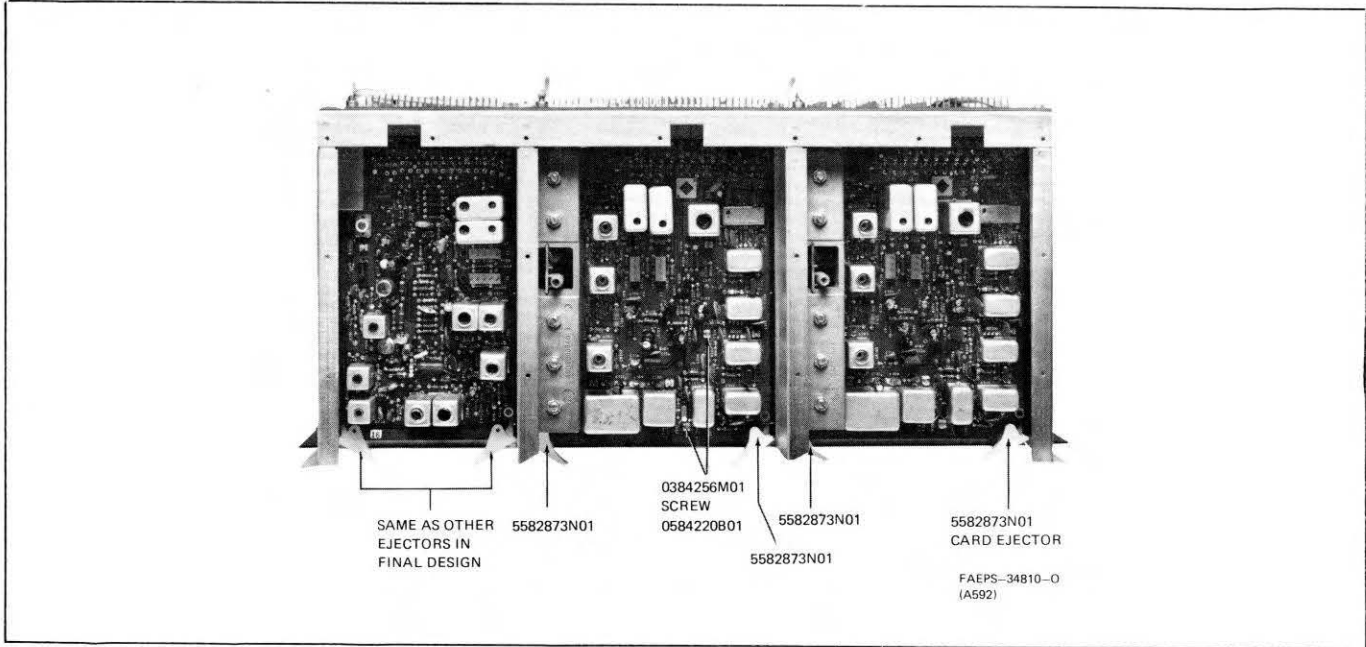
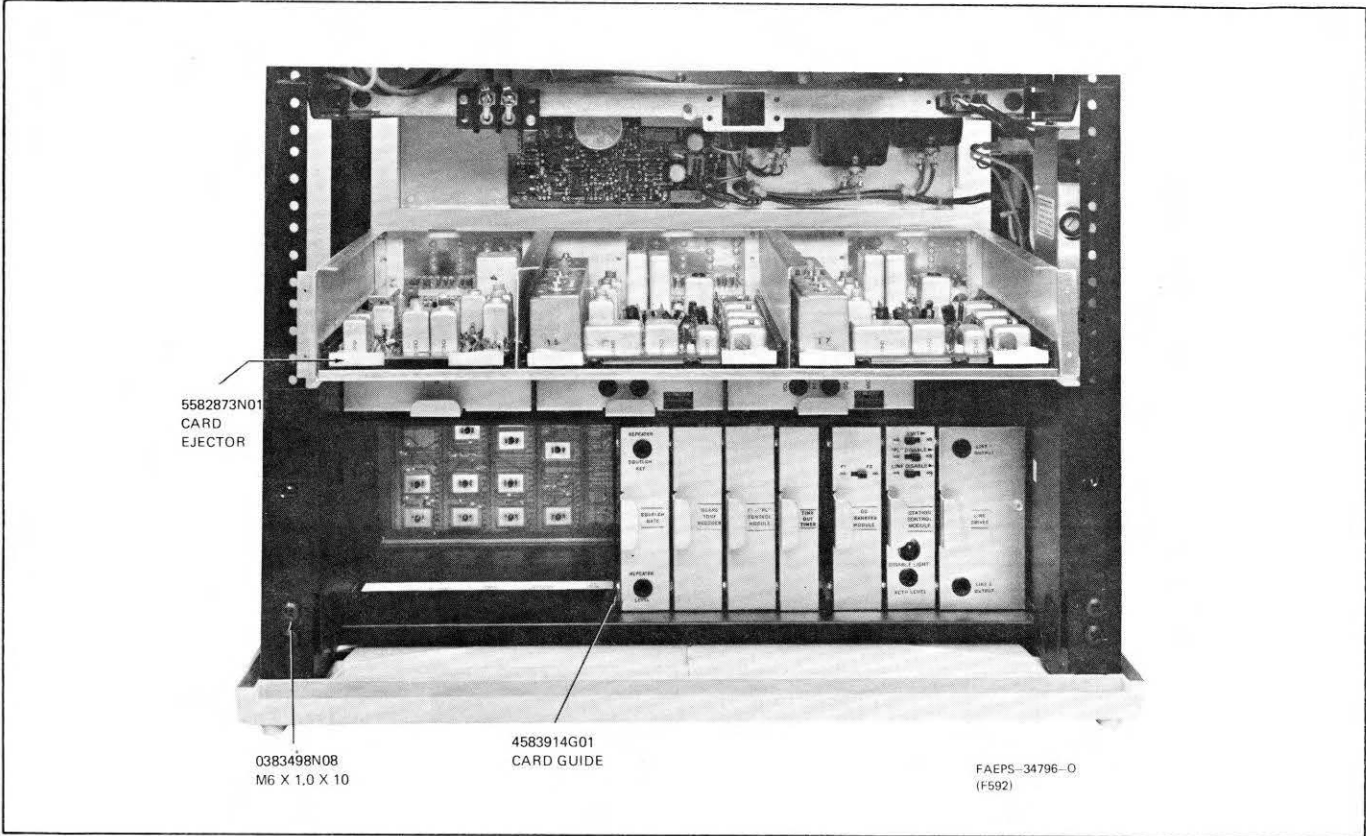

STATION MAINTENANCE

*MSR 2000 Fully Optionable Model Station
Mechanical Parts Identification
Motorola No. PEPS-34952-A
(Sheet 3 of 4)
11/15/82 · V & G*

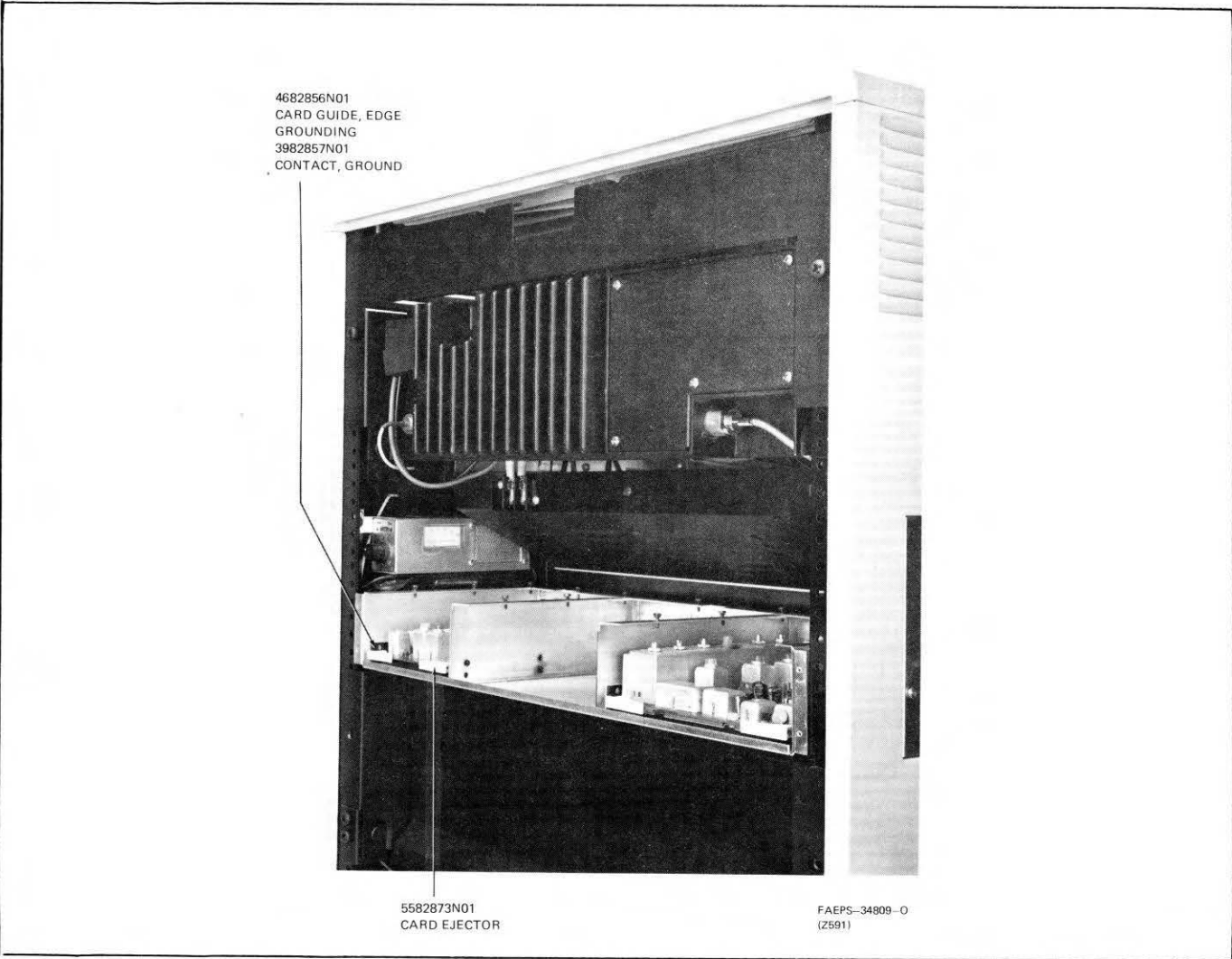
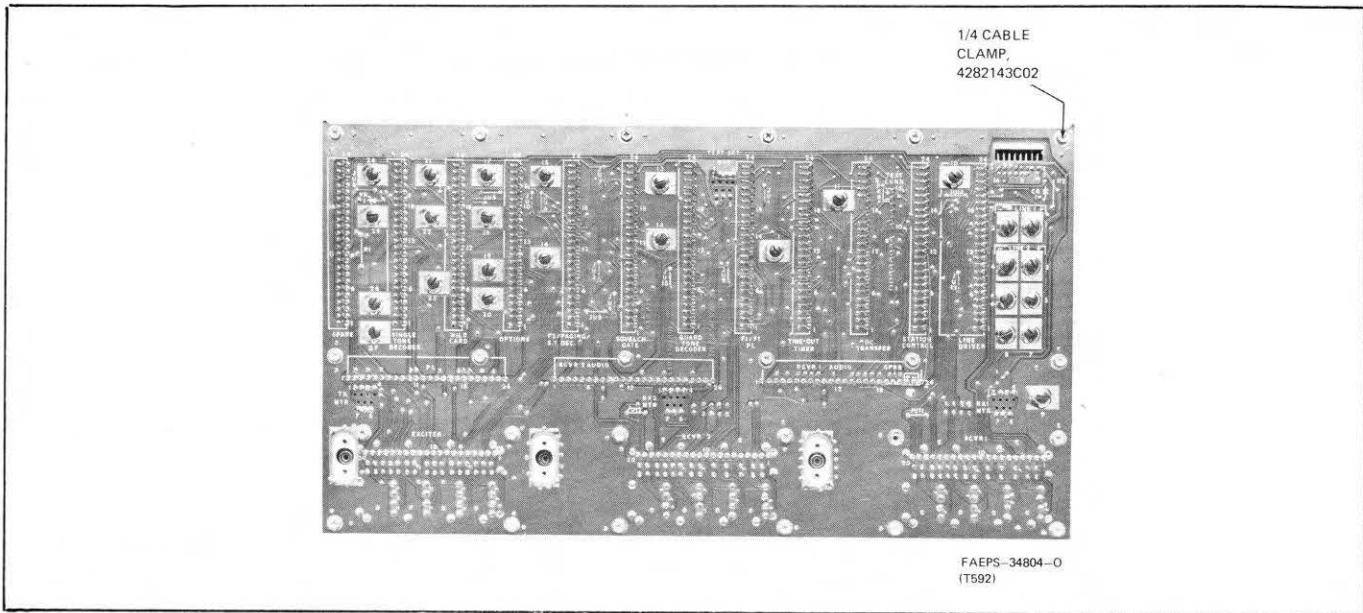

*MSR 2000 Fully Optionable Model Station
Mechanical Parts Identification
Motorola No. PEPS-34952-A
(Sheet 4 of 4)
11/15/82 - V & G*

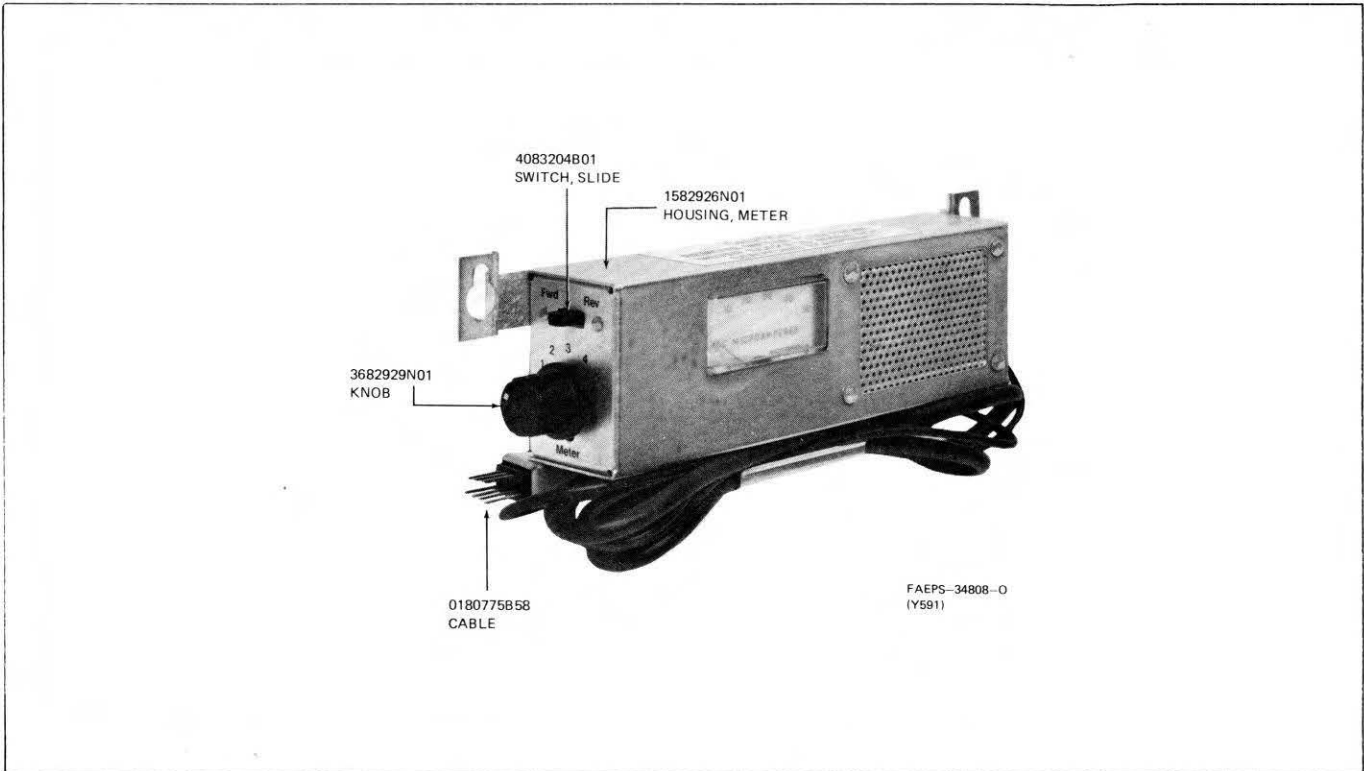

*MSR 2000 Base Station
Service Intercom with Speaker and
DC Metering Chassis Mechanical Parts Identification
Motorola No. FAEPS-34808-O*

11/15/82 - V & G

INTERMITTENT DUTY POWER AMPLIFIER

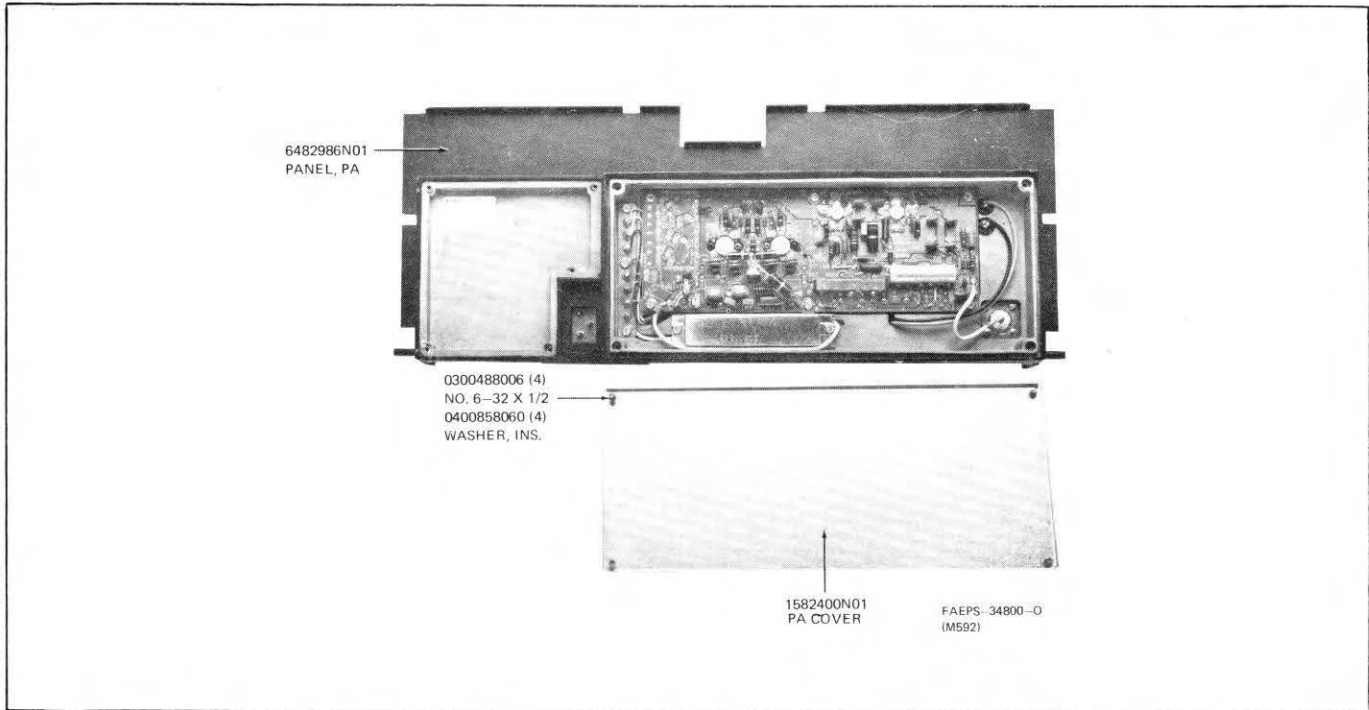

CONTINUOUS DUTY POWER AMPLIFIER

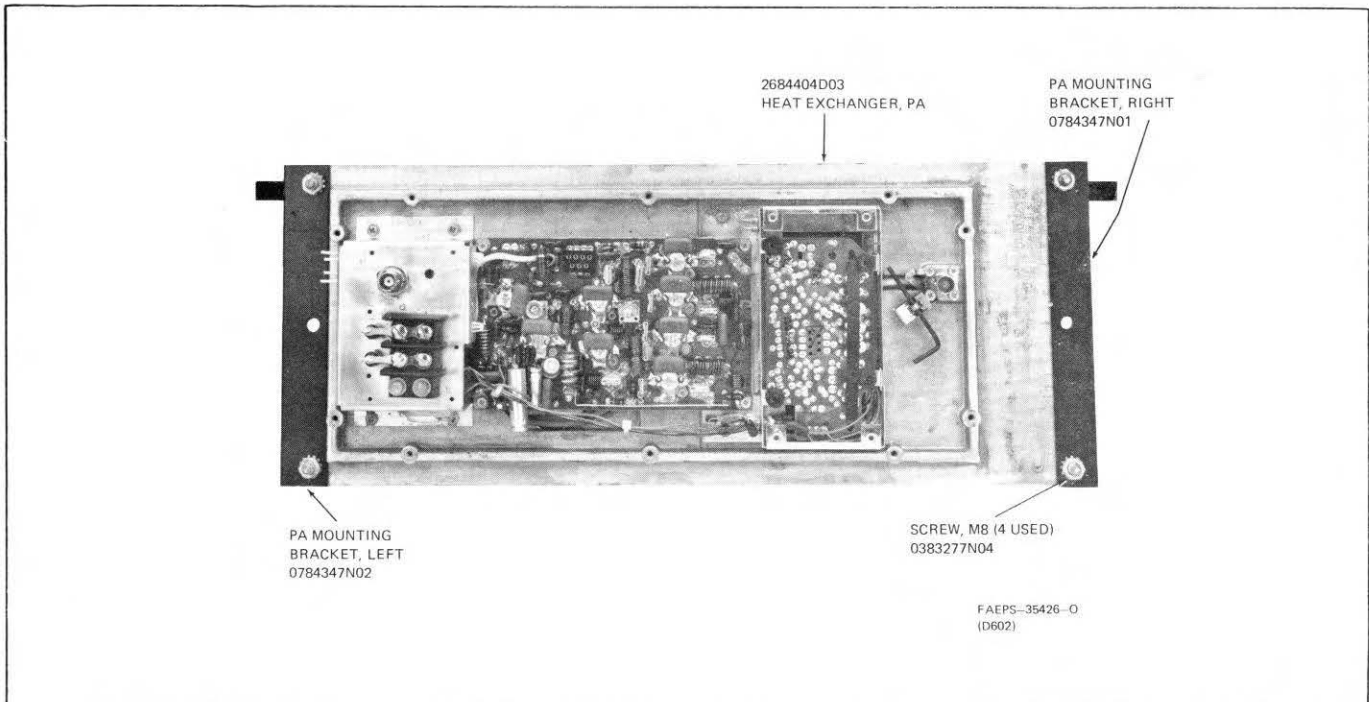

*MSR 2000 Base Station
Power Amplifier Mechanical Parts Identification
Motorola No. PEPS-35510-O
11/15/82 - V & G*

parts list

TRN5423A 24" Cabinet Hardware PL-8041-B

REFERENCE SYMBOL	MOTOROLA PART NO.	DESCRIPTION
	3-83677N01	SCREW, captive; M6 x 1.0 x 2.0; 2 used
	42-10128A10	RETAINER, ring; 2 used
	43-84510G01	SPACER; 2 used
	4-10058B37	WASHER, nylon; 6 used
	3-10943J41	SCREW, tapping; TT8 x 1.25 x 16; 4 used
	3-83498N08	SCREW, tapping; M6 x 1.0 x 10; 10 used
	3-83498N10	SCREW, tapping; M3.5 x 0.8 x 8; 6 used
	7-82831N03	FRAME, cabinet
	7-82831N04	FRAME, cabinet
	7-82881N01	BRACKET, pivot: right
	7-82881N02	BRACKET, pivot: left
	15-82821N01	HOUSING, bottom
	42-10217A02	TIE WRAPS (21 used)
	42-82143C09	CABLE CLAMPS, clear (7 used)
	42-82143C02	CABLE CLAMPS, 1/4" (2 used)
	3-134186	SCREW, tapping (2 used)
	3-135500	SCREW, tapping 4-40 x 1/4 (4 used)

TRN5425A 24" Cabinet Shell PL-8042-A

REFERENCE SYMBOL	MOTOROLA PART NO.	DESCRIPTION
	3-10943J41	SCREW, tapping; TT8 x 1.25 x 16; 4 used
	3-10943J45	SCREW, tapping; TT8 x 1.25 x 40 (2 used)
	15-82821N02	HOUSING, top
	15-82832N02	COVER, wraparound
	75-82154D17	PAD, foam; 2 used

TRN5424A Cabinet 29" Hardware PL-8070-B

REFERENCE SYMBOL	MOTOROLA PART NO.	DESCRIPTION
	3-10943J41	SCREW, tapping; TT8 x 1.25 x 16; 4 used
	3-83498N08	SCREW, tapping; M6 x 1.0 x 10; 10 used
	3-83498N10	SCREW, tapping; M3.5 x 0.8 x 6; 6 used
	7-82831N05	FRAME, cabinet
	7-82831N06	FRAME, cabinet
	7-82881N01	BRACKET, right
	7-82881N02	BRACKET, left
	15-82821N01	HOUSING, plastic
	42-10217A02	TIE WRAPS (21 used)
	42-82143C09	CABLE CLAMPS, clear (7 used)
	42-82143C02	CABLE CLAMPS, 1/4" (2 used)
	3-134186	SCREW, tapping (2 used)
	3-135500	SCREW, tapping 4-40 x 1/4 (6 used)
	4-10058B37	WASHER, nylon; 6 used

TRN5426A Cabinet 29" Shell PL-8071-A

REFERENCE SYMBOL	MOTOROLA PART NO.	DESCRIPTION
	3-10943J41	SCREW, tapping; TT8 x 1.25 x 16; 4 used
	3-10943J45	SCREW, tapping; TT8 x 1.25 x 40; 2 used
	15-82821N02	HOUSING, plastic top
	15-82832N03	COVER, cabinet
	75-82154D17	PAD, foam; 2 used

TRN5569A Cabinet 32" Shell PL-8224-O

REFERENCE SYMBOL	MOTOROLA PART NO.	DESCRIPTION
	3-10943J41	SCREW, tapping TT8 x 1.25 x 16; 4 used
	3-10943J45	SCREW, tapping; TT8 x 1.25 x 40; 2 used
	15-82821N02	HOUSING, tap
	15-82832N04	COVER, cabinet
	75-82154D17	PAD; 2 used

TRN5567A Cabinet 32" Hardware PL-8222-A

REFERENCE SYMBOL	MOTOROLA PART NO.	DESCRIPTION
	3-134186	SCREW, tapping; 6-32 x 5/16"; 2 used
	3-10943J41	SCREW, tapping; TT8 x 1.25 x 16"; 4 used
	3-83498N08	SCREW, tapping; star; 12 used
	3-83498N10	SCREW, tapping; star; 6 used
	7-82831N07	FRAME, cabinet
	7-82831N08	FRAME, cabinet
	7-82881N01	BRACKET, pivot right
	7-82881N02	BRACKET, pivot left
	15-82821N01	HOUSING, bottom
	42-10217A02	STRAP, tie: 0.91 x 3.62 nylon WHT; 26 used
	42-82143C09	CLAMP, cable; 7 used
	3-135500	SCREW, tapping; 4-40 x 1/4"; 4 used
	42-82143C05	CLAMP, cable; 2 used
	4-10058B37	WASHER, nylon; 6 used

TRN5570A Cabinet 37" Shell PL-2828-O

REFERENCE SYMBOL	MOTOROLA PART NO.	DESCRIPTION
	3-10943J41	SCREW, tapping; TT8 x 1.25 x 16; 4 used
	3-10943J45	SCREW, tapping; TT8 x 1.25 x 40; 2 used
	15-82821N02	HOUSING, top
	15-82832N05	COVER, cabinet
	75-82154D17	PAD: 2 used

TRN5568A Cabinet 37" Hardware PL-2827-A

REFERENCE SYMBOL	MOTOROLA PART NO.	DESCRIPTION
	3-134186	SCREW, tapping; 6-32 x 5/16"; 2 used
	3-135500	SCREW, tapping; 4-40 x 1/4"; 4 used
	3-10943J41	SCREW, tapping; TT8 x 1.25 x 16; 4 used
	3-83498N08	SCREW, tapping; star; 12 used
	3-83498N10	SCREW, tapping; star; 6 used
	7-82831N09	FRAME, cabinet
	7-82831N10	FRAME, cabinet
	7-82881N01	BRACKET, pivot right
	7-82881N02	BRACKET, pivot left
	15-82821N01	HOUSING, bottom
	42-10217A02	STRAP, tie: .091 x 3.62 nylon; 26 used
	42-82143C05	CLAMP; cable; 2 used
	42-82143C09	CLAMP, cable; 7 used
	4-10058B37	WASHER, nylon; 6 used

TRN5350A Junction Box, Simplex PL-8035-A
TRN5351A Junction Box, Duplex

REFERENCE SYMBOL	MOTOROLA PART NO.	DESCRIPTION
J611	15-82889N01	connector, receptacle:
J612	1-80758D49	HOUSING, 3-contact, power cord
	9-83238C01	ac outlet w/lug assembly includes:
	29-85911B	OUTLET, ac; 3-prong
		LUG, fasten
P610	15-83183N01	connector, plug:
		HOUSING, 3-contact

mechanical parts		
	2-10971A18	NUT, machine: M3 x 0.5; 2 used
	2-10971A18	NUT, machine: M5 x 0.8; 2 used
	3-83497N02	SCREW, machine: M5 x 0.8 x 12
	3-83497N04	SCREW, machine: M3 x 0.5 x 8; 2 used
	3-10943M10	SCREW, tapping; M3 x 0.5 x 8; 2 used
	3-83498N10	SCREW, tapping; M3.5 x 0.6 x 8; 2 used
	4-7683	LOCKWASHER, #4 internal; 2 used
	9-82845L01	CONNECTOR, crimp; 2 used
	9-83358N01	CONNECTOR, wire splice
	15-82835N01	COVER, junction box
	15-82881N01	HOUSING, fuse with mounting hardware
	29-10228A08	TERMINAL, connector
	37-106352	GROMMET
	39-83145N01	CONTACT, plug: (part for P610); 2 used
	39-83145N02	CONTACT, plug (part for P610)
	39-83384N01	CONTACT, plug: (part for J11); 3 used
	42-10217A02	CLIP, cable; 3 used
	42-82143C01	CLIP, cable; 3/16"
	15-82834N01	HOUSING, interconnect (TRN5350A)
	15-83834N03	HOUSING, interconnect (TRN5351A)

TRN5434A Hardware Optional Control Chassis, R2 Receiver PL-8051-O
TRN5435A Hardware Optional Control Chassis, Duplex

REFERENCE SYMBOL	MOTOROLA PART NO.	DESCRIPTION
	3-134185	SCREW, tapping; 6-32 x 1/4"; 4 used
	3-134186	SCREW, tapping; 6-32 x 5/16"
	3-135506	SCREW, tapping; 6-32 x 1/4"; 23 used
	27-82850N01	CHASSIS, rf
	27-82876N01	CHASSIS, card cage
	39-82857N01	CONTACT, ground; 6 used
	42-82888N01	CLIP, detent; 2 used
	46-82856N01	GUIDE, circuit board card; 6 used
	46-82877N01	GUIDE, skt. bd. mtg: (3 used; TRN5434A) (2 used; TRN5435A)
	54-83570K01	LABEL

TRN5428A Power Control Board Cover PL-8044-O

REFERENCE SYMBOL	MOTOROLA PART NO.	DESCRIPTION
	3-488006	SCREW, machine: 6-32 x 1/2"; 5 used
	4-658060	WASHER, insulator; 7/32 x 0.125 x .062; 5 used
	15-82401N01	COVER, control

MSR 2000 Base Station
Miscellaneous Parts Lists
Motorola No. PEPS-34953-C
(Sheet 1 of 2)
1/14/83- V & G

STATION MAINTENANCE

parts list

TRN5431A Cover Repeater PL-8088-O

REFERENCE SYMBOL	MOTOROLA PART NO.	DESCRIPTION
	2-82360B35	NUT, speed
	3-125178	SCREW, machine: 8-32 x 3/4"
	3-83498N02	SCREW, tapping: M3 x 0.5 x 5
	4-647583	WASHER, fiber
	14-82835N01	INSULATOR, terminal block
	15-82858N01	COVER, mode F0
	15-83031N01	COVER, aux, chassis
	42-10128A10	RETAINER, ring rubber

TRN5433A Hardware Optional Control Chassis (1-Receiver) PL-8089-O

REFERENCE SYMBOL	MOTOROLA PART NO.	DESCRIPTION
	3-134185	SCREW, tapping: 8-32 x 1/4"; 4 used
	3-134186	SCREW, tapping: 6-32 x 5/16"
	3-135506	SCREW, tapping: 6-32 x 1/4"; 23 used
	27-82850N01	CHASSIS, rf
	27-82876N01	CHASSIS, card cage
	39-82857N01	CONTACT, ground; 4 used
	42-82888N01	CLIP, detent; 2 used
	46-82858N01	GUIDE, circuit board card; 4 used
	46-82877N01	GUIDE, circuit board mounting; 2 used
	54-83570K01	LABEL

TKN8326A Cable Kit PL-8228-O

REFERENCE SYMBOL	MOTOROLA PART NO.	DESCRIPTION
	1-80763D70	CABLE, coaxial assembly includes:
	28-82331G01	PLUG, single contact (1 used)
	28-82875N01	PLUG, phono; board mount (1 used)
	30-83794C01	COAX CABLE; 45" long
	1-80757D15	CABLE, coaxial assembly includes:
	28-82331G01	PLUG, single contact (1 used)
	30-83794C01	COAX CABLE; 3 1/2" long
	42-10217A02	STRAP, tie (6 used)

TRN5575A Power Supply Cover PL-8206-O

REFERENCE SYMBOL	MOTOROLA PART NO.	DESCRIPTION
	3-83498N08	SCREW, tapping; star; 5 used
	26-84448N01	SHIELD, top
	26-84384N01	SHIELD

TRN5427A Power Cord 110 V PL-8043-O

REFERENCE SYMBOL	MOTOROLA PART NO.	DESCRIPTION
	30-82833N01	LINE CORD; with plug and receptacle

TRN5443A Duplex RF Cover PL-8039-O

REFERENCE SYMBOL	MOTOROLA PART NO.	DESCRIPTION
	1-80756D68	Assembly Front cover eyeleted
	3-136832	SCREW, tapping: 4 x 40 x 3/8"; 15 used
	3-138430	SCREW, tapping: 4-24 x 3/8"; 4 used
	15-82852N01	COVER, top
	42-83123F01	RETAINER; 4 used

TRN5429A Cover, Basic
TRN5430A Cover, Simplex PL-8040-A

REFERENCE SYMBOL	MOTOROLA PART NO.	DESCRIPTION
	1-80758D88	ASSEMBLY COVER; includes:
	5-83124F01	EYELET; 2 used
	15-82851N01	COVER
	2-82360B35	NUT, speed
	3-125178	SCREW, machine: 8-32 x 3/4"
	3-138430	SCREW, tapping: 4-24 x 3/8"; 2 used
	3-83498N02	SCREW, tapping: M3 x 0.5 x 5
	4-647583	WASHER, fiber
	14-82835N01	INSULATOR, terminal block
	15-82858N01	COVER, mode F0 (TRN5430A)
	15-82858N02	COVER, mode basic (TRN5429A)
	15-83031N01	COVER, aux chassis
	42-10128A10	RETAINER, ring rubber
	42-83123F01	RETAINER; 2 used
	42-82879N01	CLIP; 3 used

TRN5442A Labels PL-8242-O

REFERENCE SYMBOL	MOTOROLA PART NO.	DESCRIPTION
F601	85-138179	fuse: 10 amp; 250 V
		mechanical parts
	13-813818	DECAL, patent no.
	33-83748N01	NAMEPLATE
	38-82892N01	CAP, fuse housing; GRY
	54-850440	LABEL, FCC
	54-83040C01	LABEL, audio
	54-83918N01	LABEL, interconnect housing outlet
	54-83919N01	LABEL, interconnect housing, fuse
	54-83922N01	LABEL, as pwr interconnect
	54-64126C01	LABEL, replacement parts

MSR 2000 Base Station
Miscellaneous Parts Lists
Motorola No. PEPS-34953-C
(Sheet 2 of 2)
1/14/83- V & G

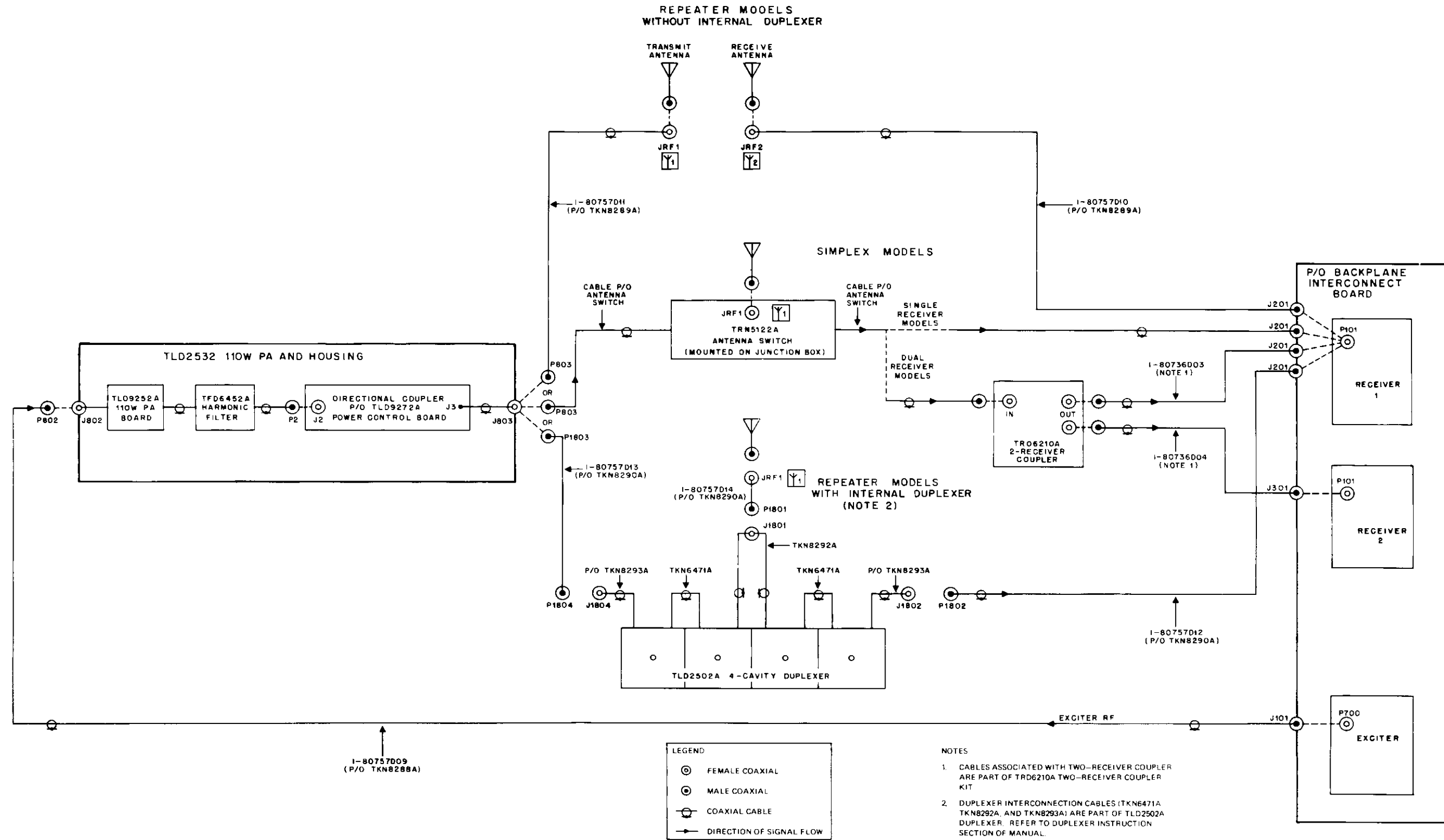

LEGEND

- ⊙ FEMALE COAXIAL
- ⊙ MALE COAXIAL
- COAXIAL CABLE
- DIRECTION OF SIGNAL FLOW

- NOTES
1. CABLES ASSOCIATED WITH TWO-RECEIVER COUPLER ARE PART OF TRD6210A TWO-RECEIVER COUPLER KIT
 2. DUPLEXER INTERCONNECTION CABLES (TKN6471A, TKN8292A, AND TKN8293A) ARE PART OF TLD2502A DUPLEXER. REFER TO DUPLEXER INSTRUCTION SECTION OF MANUAL.

DEPS - 34372 - A

parts list

REFERENCE SYMBOL	MOTOROLA PART NO.	DESCRIPTION
TKN8289A Cable Non-Duplexer PL-8058-A		
JRF1	9-82442E01	connector, receptacle: female; single contact
JRF2	9-82442E01	female; single contact
J201	28-82875N01	male; single contact (phono)
P803	28-84579F01	male; single contact (UHF)
mechanical parts		
2-10971A16		NUT, machine: M3 x 0.5; 8 used
3-83497N04		SCREW, machine: M3 x 0.5 x 8; 8 used
1-80757D10		Assembly cable non-duplexer rcvr includes: JRF2, J201
15-483599		HOOD, receptacle
30-83794C01		CABLE, coaxial (WHT) 47 1/2" used
1-80757D11		Assembly cable, non-duplexer xtrm; includes: JRF1, P803
15-483599		HOOD, receptacle
30-84173E01		CABLE, coaxial (double shield) 19 1/2" used
TKN8288A Cable PA Power and Exciter PL-8054-C		
J101	28-82875N01	connector, plug: male; single contact (phono)
P802	28-84579F04	male; single contact (UHF)
mechanical parts		
1-80757D07		Assembly, cable: PA power red; includes: TERMINAL, ring; 2 used
29-82907N03		TERMINAL, ring; 2 used
1-80757D08		Assembly, cable: PA power black; includes: TERMINAL, ring; 1 used
29-82709N03		TERMINAL, ring; 1 used
29-848903		TERMINAL, lug
1-80757D09		Assembly, cable: exciter; includes: J801, P802
30-83794C01		CABLE, coaxial (WHT) 38 1/2" used
3-134185		SCREW, tapping: 6-32 x 1/4"
42-10217A02		STRAP, tie; (WHT); 3 used
42-82143C08		CLIP, cable
TKN8290A Cable Duplexer PL-8046-A		
JRF-1	9-82442E01	connector: female; single contact
J201	28-82875N01	male; single contact
P1802, 1803, 1804	28-84579F01	connector, plug: male; single contact
mechanical parts		
2-10971A16		NUT, machine: M3 x 0.5; 4 used
3-83497N04		SCREW, machine: M3 x 0.5 x 8; 4 used
42-10217A02		STRAP, tie; 2 used
1-80757D12		ASSEMBLY, cable receiver: includes J201, P1804
1-80757D13		ASSEMBLY, cable transmitter: includes: P1802, 1803
30-83794C01		CABLE, coaxial; 38-1/2" used
1-80757D14		ASSEMBLY, cable: 44" used
30-84173E01		CABLE, coaxial: 44" used
15-483599		HOOD, receptacle
28-84579F01		PLUG, UHF
30-84173E01		CABLE, coaxial; 33" used

MSR 2000 Intermittent Duty Base Station
RF Interconnecting Diagram & Parts List
Motorola No. PEPS-34954-C
9/13/84 - V & G

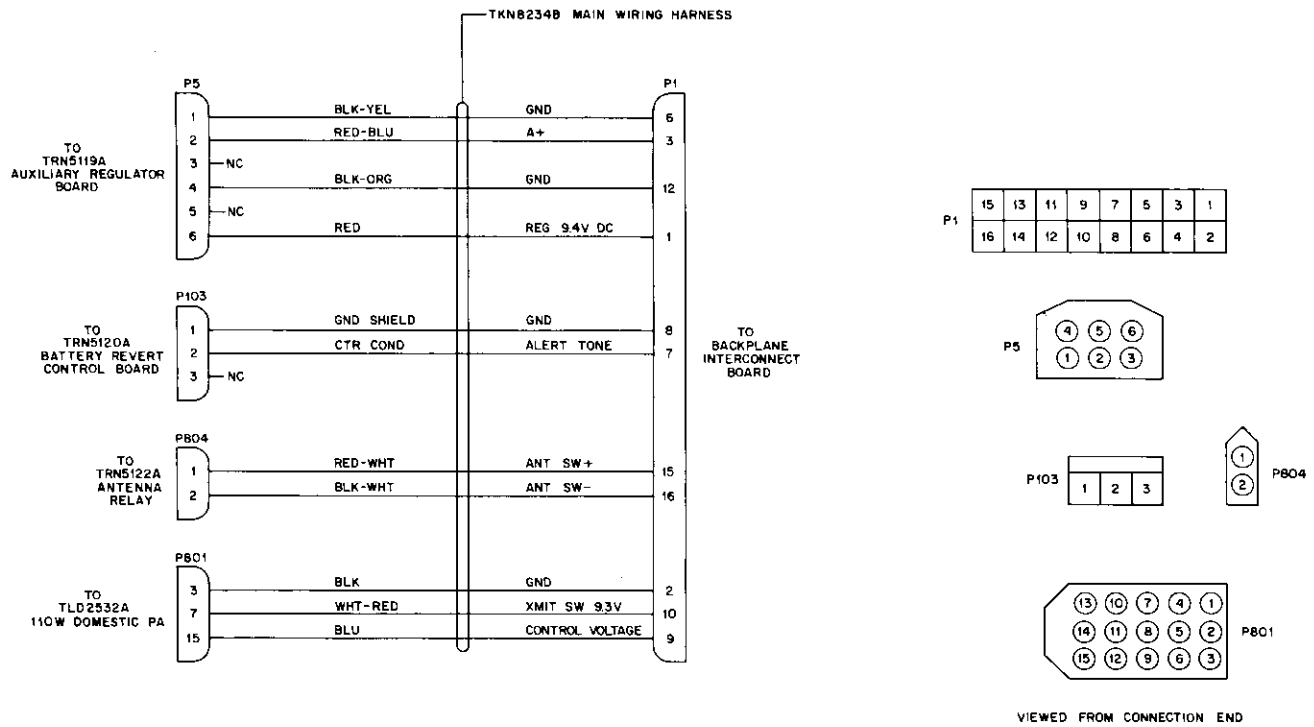

DEPS-34674-A

parts list

TKN8234B Main Cable

PL-8053-C

REFERENCE SYMBOL	MOTOROLA PART NO.	DESCRIPTION
connector, receptacle:		
P1	15-84248N01	16 position
P5	15-84954L01	6 position
P103	15-83498F39	3 position
P801	15-83292K02	15 position
P804	15-84860K02	2 position
mechanical parts		
	29-84249N01	TERMINAL; 11 used
	29-84706E05	TERMINAL: crimp pin; 4 used
	29-84706E06	TERMINAL: crimp socket; 5 used
	30-824278	CABLE, shielded (ORG) 49 1/4" used
	42-10217A02	STRAP, tie; 18 used
	29-83499F01	TERMINAL; 2 used

*MSR 2000 Intermittent Duty Base Station
TKN8234B Main Wiring Harness
Schematic Diagram and Parts List
Motorola No. PEPS-34955-D
9/13/84-*

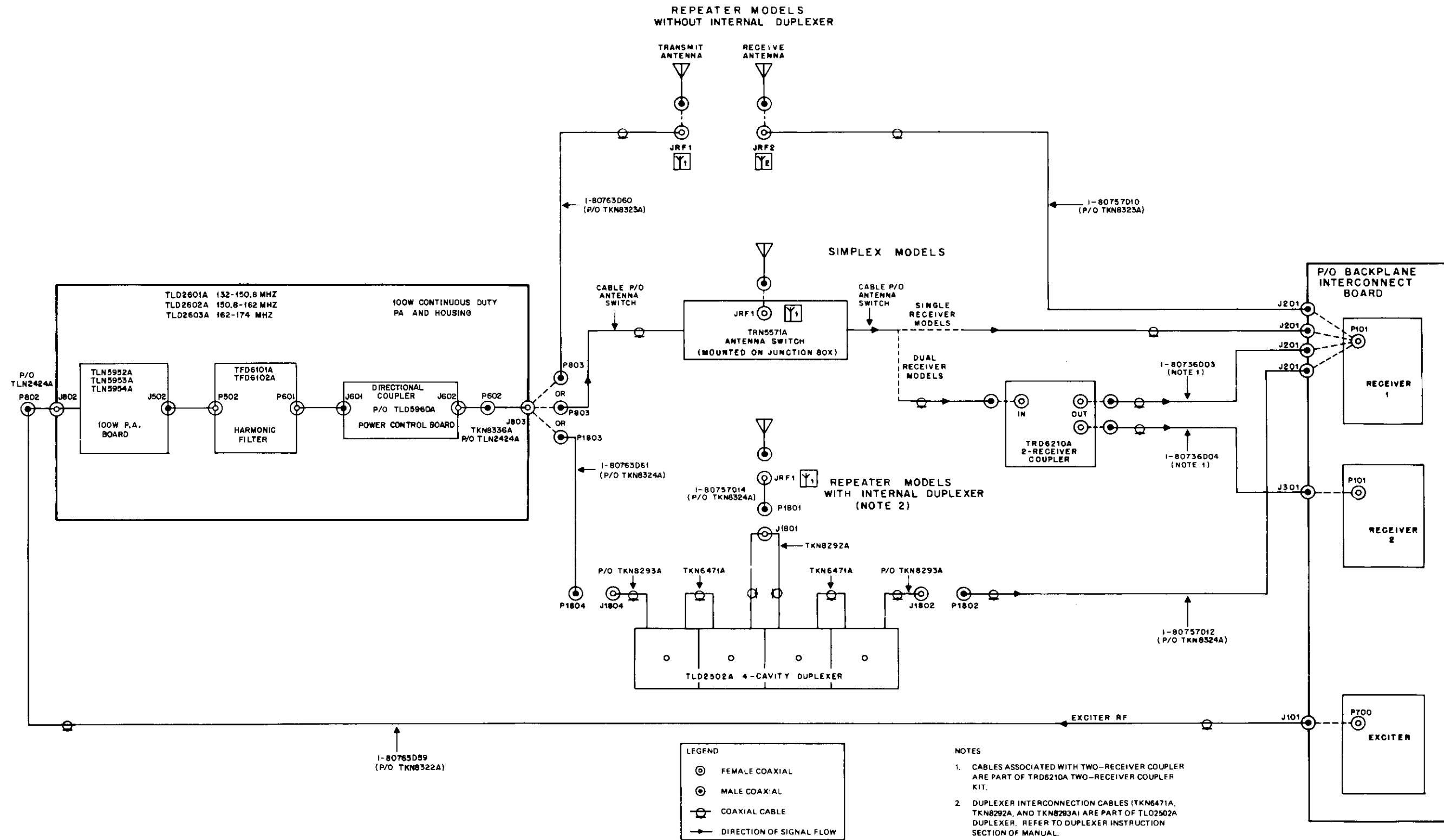

parts list

REFERENCE SYMBOL	MOTOROLA PART NO.	DESCRIPTION
JRF1, 2	9-82442E01	connector, receptacle: female; single-contact (UHF)
J201	29-82875N01	male; single-contact (phono)
P803	28-84987D01	male; single-contact (BNC)
mechanical parts		
	1-80757D10	ASSEMBLY CABLE, non-duplexer, RCVR; includes: JRF2, J201
	5-82050H04	EYELET
	15-483599	HOOD, receptacle
	30-83794C01	CABLE, coaxial (WHT) 48" used
	1-80763D65	ASSEMBLY CABLE, non-duplexer EIA rack includes: 15-483599
	30-84173E01	CABLE, coaxial shielded; 36" used (TKN8329A)
	1-80763D60	ASSEMBLY CABLE, non-duplexer XMTR includes: JRF1, P803
	15-483599	HOOD, receptacle
	30-84173E01	CABLE, coaxial shielded 28" used (TKN8323A)
TKN8328A Cable PA Power and Exciter EIA Rack		
PL-8223-A		
REFERENCE SYMBOL	MOTOROLA PART NO.	DESCRIPTION
J101	28-82875N01	connector, plug: male; single-contact (phono)
P802	28-83099K01	male; single-contact (BNC)
mechanical parts		
	1-80763D57	ASSEMBLY CABLE, PA power, RED; includes: 29-82907N03
	1-80763D58	ASSEMBLY CABLE, PA power, BLK; includes: 29-848903
	29-848903	LUG, crimp terminal
	29-82907N03	TERMINAL, ring
	1-80763D59	ASSEMBLY CABLE, exciter; includes: J801, P802
	5-82050H04	EYELET
	30-83794C01	CABLE, coaxial (WHT) 51" used (TKN8322A)
	1-80763D64	ASSEMBLY CABLE, exciter; (EIA) includes: J801, P802
	5-82050H04	EYELET
	30-83794C01	CABLE, coaxial (WHT) 64" used (TKN8328A)
TKN8324A Cable Duplexer		
PL-8220-O		
REFERENCE SYMBOL	MOTOROLA PART NO.	DESCRIPTION
JRF1	9-82442E01	connector, receptacle: female; single-contact
J201	28-82875N01	male; single-contact (phono)
P1801, 1802	28-84579F01	connector, plug: male; single-contact
P1803	28-84987D01	male; single-contact
P1804	28-84579F01	male; single-contact
mechanical parts		
	1-80757012	ASSEMBLY CABLE DUPLEXER (RCVR) includes: J201, P1804
	5-82050H04	eyelet
	30-83794C01	CABLE, coaxial (WHT) 30" used
	1-80754D14	ASSEMBLY CABLE ANTENNA DUPLEXER; includes: JRF1, P1801
	15-483599	HOOD, receptacle
	30-84173E01	CABLE, coaxial double shielded; 30-1/2" used
	1-80763D61	ASSEMBLY CABLE DUPLEXER (XMTR) includes: P1802, 1803
	30-8173E01	CABLE, coaxial; 50" used
	2-10971A16	NUT, machine; M3 x 0.5; 4 used
	3-83487N04	SCREW, machine; M3 x 0.5 x 8; 4 used
	42-10217A02	STRAP, tie .091 x 3.62 nylon; 2 used

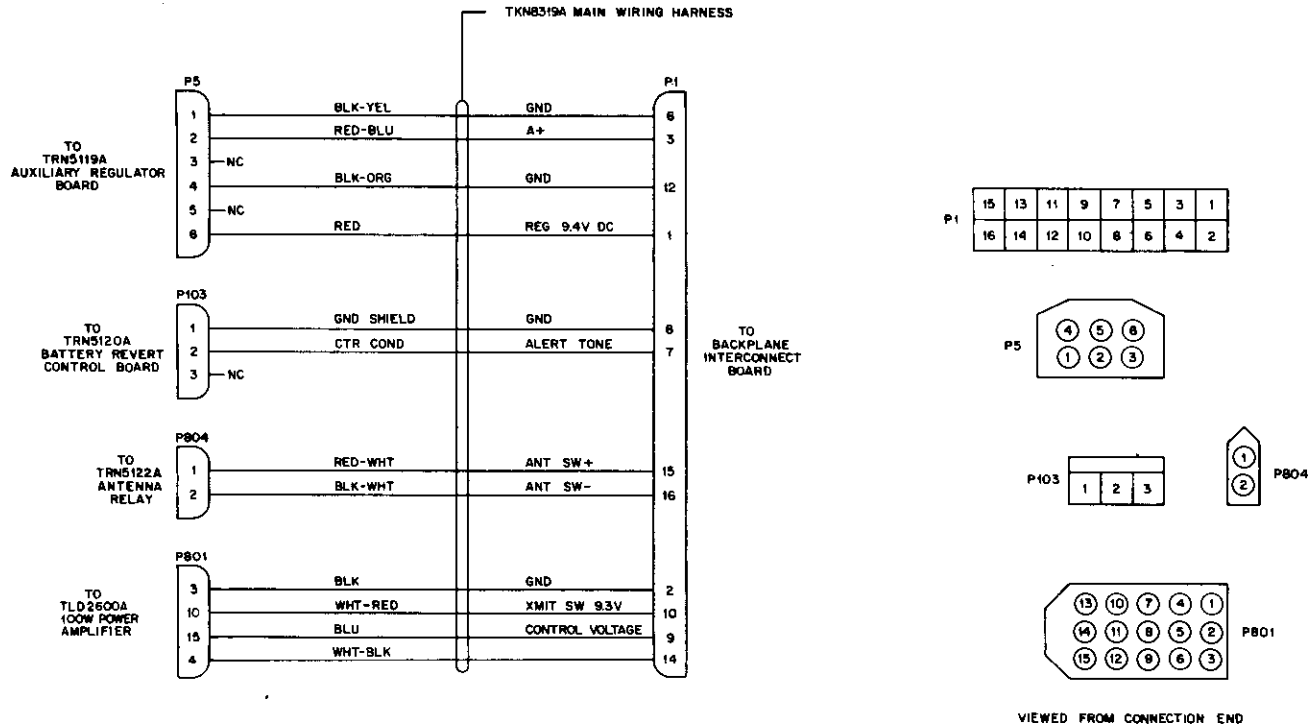

OEPS-35287-0

parts list

TKN8319A Main Cable

PL-8225-O

REFERENCE SYMBOL	MOTOROLA PART NO.	DESCRIPTION
P1	15-84248N01	connector, receptacle: 16 position
P5	15-84954L01	6 position
P103	15-83498F39	3 position
P801	15-83292K02	15 position
P804	15-84880K02	2 position
mechanical parts		
	29-84249N01	TERMINAL; 12 used
	29-83499F01	TERMINAL; 2 used
	29-84706E05	TERMINAL: crimp pin; 4 used
	29-84706E06	TERMINAL: crimp socket; 6 used
	30-824278	CABLE, shielded (ORG) 52" used
	42-10217A02	STRAP, tie; 47 used

MSR 2000 Continuous Duty Base Station
TKN8319A Main Wiring Harness
Schematic Diagram and Parts List
Motorola No. PEPS-35372-O

11/15/82 - V & G

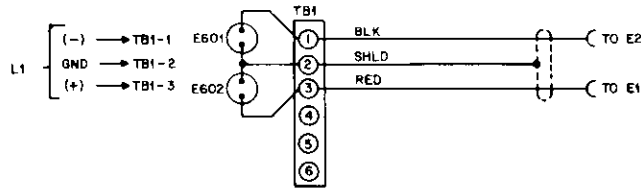

TKN8286A TWO-WIRE LINE CABLE KIT

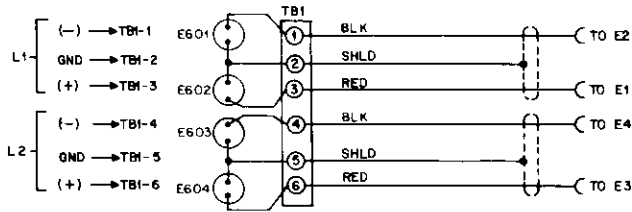

TKN8287A FOUR-WIRE LINE CABLE KIT

•8EPS-34736-0

parts list

TKN8320A and TKN8321A Two-Wire and Four-Wire EIA Cable Kit
TKN8286A and TKN8287A Two-Wire and Four-Wire Line Cable Kit PL-8052-A

REFERENCE SYMBOL	MOTOROLA PART NO.	DESCRIPTION
E601 thru 604	80-83029H01	spark, gap: 240 V
mechanical parts		
	29-812979	LUG, crimp terminal: TKN8286A, TKN8320A; 2 used; TKN8287A, TKN8321A; 4 used
	30-844810	CABLE, 2-conductor shielded; 31-1/2" used (TKN8287A, TKN8286A)
	30-844810	CABLE, 2-conductor shielded; 34" used (TKN8287A)
	30-844810	CABLE, 2-conductor shielded; 38" used (TKN8321A, TKN8320A)
	30-844810	CABLE, 2-conductor shielded; 40-1/2" used (TKN8321A)
	31-82893N01	TERMINAL, block with mounting rings
	42-10217A02	STRAP, tie; TKN8286A, TKN8320A; 2 used; TKN8287A, TKN8321A; 2 used

STATION MAINTENANCE

*TKN8320A and TKN8321A Two-Wire and Four-Wire EIA Cable Kit
TKN8286A and TKN8287A Two-Wire and Four-Wire Line Cable Kit
Schematic Diagram and Parts List
Motorola No. PEPS-34956-A*

11/15/82 - V & G

1. INTRODUCTION

1.1 This section of the manual details procedures required in the overall maintenance of the station. Specific troubleshooting and alignment procedures are given in the appropriate section of this manual, such as receiver, transmitter, etc. Maintenance checks for control modules are given in the applicable module section in the separate Control and Audio Instruction Manual 68P81061E40.

1.2 The first section gives the procedures required to locally operate the station during servicing. This allows service personnel to operate all functions of the station without an operator present at the control site.

1.3 The second section provides a list of routine maintenance procedures that should be performed periodically or whenever the station is serviced. Also, a list of recommended test equipment is provided.

1.4 The last section explains how to disassemble and gain access to the various parts of the station and contains the station mechanical parts identification and station intercabling diagrams. This station is designed for easy service access. Usually, all servicing can be performed with the housing in place on the station by removing only the locking front cover.

2. LOCAL OPERATION

2.1 GENERAL

Once power is applied and the station is properly adjusted, the base or repeater station is normally operated entirely unattended from a remote control point. The station may be manually operated utilizing controls on the control modules in the station chassis. This type of operation may be necessary to accomplish station maintenance and testing. The switch functions are given in Table 1.

WARNING

The transmitter can be keyed remotely. To prevent unexpected transmitter keying while servicing the station, be sure the **LINE DISABLE** switch is actuated (direction of arrow). Also, the TRN5324A Squelch Gate Module must be temporarily removed from the remote control chassis if the station is equipped with any of the following dc transfer modules:

TRN5329A
TRN5240A
TRN5257A

To prevent PA damage, be sure the **LINE DISABLE** switch is actuated and do not locally key the station while having more than one channel element selected.

Table 1. Station Control Module Switch Functions

Switch	Position	Functions Possible
XMIT	Normal (not actuated)	Normal mode of operation
	Actuated (hold to right)	Turns transmitter on with no modulation. Use test microphone connected to Local Mic receptacle to modulate transmitter.
PL DISABLE* (functional only in Private-Line stations or Digital Private-Line)	Normal (left)	Only PL/DPL-coded on-frequency signals accepted by receiver.
	Actuated (right)	All on-frequency signals accepted by receiver.
LINE DISABLE*	Normal (left)	Transmitter can be operated by: 1. XMIT switch 2. Local microphone 3. Remote control console
	Actuated (right)	Transmitter can <i>not</i> be operated by remote control console over control line.

*The DISABLE LIGHT is illuminated when the LINE DISABLE or PL DISABLE switch is actuated.

The following procedures pertain to the local operation of a remotely controlled station or repeater station.

2.2 TRANSMITTER CONTROL

To prevent the transmitter from being keyed remotely, set station control module LINE DISABLE switch in the direction of the arrow. At conclusion of local operation, be sure that the LINE DISABLE switch is returned to its normal position (opposite direction of arrow).

2.3 LOCAL MICROPHONE

Connect a microphone (Motorola Model TMN5064A or equivalent) to the microphone receptacle on the R1 Audio Module. This microphone may be used as a local microphone, and to key the transmitter.

2.4 LOCAL SPEAKER

2.4.1 Stations Without Optional Speaker or Meter and Speaker Box

Connect an 8-ohm, 1-watt test speaker to pins 22 (+) and 23 (-) at the R1 Audio Module edge connector on the station backplane interconnect board. This speaker is used to monitor all received messages.

2.4.2 Stations With Optional Speaker or Meter and Speaker Box

Connect the speaker lead from the speaker box to pins 22 (+) and 23 (-) of the R1 Audio Module edge connector on the station backplane interconnect board. Place the Speaker On-Off switch to the On position. The Speaker On-Off switch is located on the side of the Speaker or Meter and Speaker Box mounted toward the back of the station. The box may be removed from its mounting in the station for access.

2.5. HANDSET

A Motorola handset (Model TMN6057A) may be used to provide local audio, microphone, and transmit push-to-talk. Connect the handset to the microphone receptacle on the R1 Audio Module.

2.6 PORTABLE TEST SET (FOR STATIONS WITHOUT BUILT-IN METERING)

A Motorola S1056-S1059 Series Portable Test Set with TEK-37 or TEK-37A Adapter Cable can be used as a local control facility. Connect the red "control" plug of the adapter cable to the metering receptacle on the unified chassis interconnect board. The speaker in the test set can be used for monitoring received signals and an optional microphone (Model TMN6054A) connected to the microphone receptacle on

the test set can be used for originating transmissions. The XMIT button on the test set can be used to key the transmitter without voice modulation.

2.7 FREQUENCY SELECTION

For stations with a two-frequency transmitter, the frequency can be locally selected by the F1-F2 switch on the dc transfer module or on the F2 tone decoder module. For stations with a two-frequency receiver, frequency selection is made by momentarily operating the REC F1 SELECT or REC F2 SELECT switch on the dc transfer module or on the F2 tone decoder module. For four-frequency stations, the frequency is selected by *momentary* operation of the desired frequency select switch on the four-frequency control module *after* the XMIT switch on the station control module is actuated.

2.8 SELECTION OF OTHER MODES

All other functions that can be activated by remote control can also be activated locally. Each module has test switches to activate any such functions, such as RPTR ON and RPTR OFF. Most of these switches are momentary action, which causes the station to operate in the selected mode as long as the switch is held. The station will return to normal operation when the switch is released.

2.9 RECEIVED AUDIO

After the local speaker is turned on, or connected, the station is ready to receive audio. The receiver PL feature, if used, can be defeated by setting the station control module PL DISABLE switch in the direction of the arrow. (At the conclusion of local operation, be sure that the PL DISABLE switch is returned to its normal position.) If necessary, the receiver can be un-squelched utilizing the receiver SQUELCH control on the receiver chassis. The VOLUME control on the receiver chassis sets the audio output level of the local speaker.

2.10 TRANSMITTING

NOTE

Before initiating any local transmissions, monitor the channel to be sure that it is clear of other transmissions.

The transmitter is locally keyed by either activating the station control module XMIT switch or activating the push-to-talk microphone switch. Voice is transmitted using the local microphone.

2.11 CONCLUDING LOCAL OPERATION

At the conclusion of local operation, perform the following operations and checks to be sure that the station is ready for remote operation.

Step 1. Reset receiver squelch level per procedures in the Receiver Alignment section of this manual.

Step 2. Be sure that station control module switches are positioned for normal operation (reference Table 1).

Step 3. Disconnect microphone and test speaker (if used).

Step 4. Set all external power switches ON.

Step 5. Be sure that station is operable from remote location.

Step 6. Turn local speaker OFF (if applicable).

Step 7. Disconnect or remove any metering plugs or test set.

Step 8. Be sure that the cabinet door is locked.

Step 9. Be sure that vents in cabinet are unobstructed.

3. MAINTENANCE TECHNIQUES

3.1 GENERAL

Specific maintenance procedures for individual chassis, which comprise this station, are contained in the latter paragraphs of this section. Control module maintenance information is provided in the separate Control and Audio manual 68P81061E40. As an aid to isolating a malfunction to a specific chassis or module, a variety of general techniques are appropriate. Refer to Table 2 for routine maintenance checklist.

3.2 TRANSMITTER AND RECEIVER

Most troubles in the transmitter or receiver can be quickly isolated with metering checks. A log of normal meter readings *for this station* should be maintained. Each time maintenance is performed, the meter readings should be entered into the log. Variations from the previous readings can help to isolate a malfunction or may indicate an impending failure. If no previous meter readings are available, typical or minimum meter readings may be found in the receiver, exciter, and power amplifier sections as well as metering procedures.

3.3 POWER SUPPLY

A check of power supply voltages under load and no-load conditions (transmit and standby) should quickly isolate any malfunction.

3.4 REMOTE CONTROL UNIT

Isolation of a malfunction in the control portion of the rf control chassis requires a functional understanding of the overall station operation and the inter-relationship between the various modules and chassis of the station. The Functional Description section along with the Control Modules section of manual 68P81061E40 provide necessary information. With a basic understanding of station operation, troubles may be isolated by analyzing the following questions:

- (1) Can the station be operated locally but not remotely? If so, this eliminates many circuits as possible sources of trouble.

Table 2. Routine Maintenance Checklist

Item	Check
Receiver	Measure the signal level required to obtain 20 dB quieting.
	Compare meter readings with the minimum value and all previous readings taken. Realign the receiver, if necessary.
	For PL stations, check for proper operation of the PL decoder. Does the squelch open when the proper PL tone or binary code is detected?
	Verify receiver frequency, adjust if necessary.
Transmitter	Measure transmitter output power.
	Compare meter readings with the minimum value and all previous readings taken. Realign the transmitter, if necessary.
	Verify that each transmitter channel is on frequency and adjust if necessary.
	Tune and load the transmitter to the antenna.
	Measure transmitter frequency deviation for both voice and PL coded modulation. Adjust the "IDC" control, if necessary.
System Operation	Measure the exciter modulator sensitivity.
	Measure and adjust the audio input to the exciter.
	Measure and adjust the receiver(s) audio output to the control line.
	Check control line levels and functions for proper operation.
	Adjust receiver(s) on frequency with the distant transmitter(s) in the system.
After Performing Maintenance	Check for proper repeater operation on repeater models.
	Check all accessory equipment for proper operation.
	Check all items listed in the <i>Concluding Local Operation</i> paragraph of this section of the instruction manual.

(2) How many modes are inoperable? Concentrate testing on circuits that are common to the inoperable modes.

(4) Are jumpers properly installed? The many jumpers in this station provide vast flexibility, but could be a source of trouble if improperly added, removed, or not removed, as the case may be.

(3) Are adjustments properly set? This includes audio level adjustments at the station *and at the remote control point*.

4. RECOMMENDED TEST EQUIPMENT

A list of recommended test equipment for maintenance of this station is given in Table 3.

Table 3. Recommended Test Equipment

Type of Equipment or Type of Measurement	Equipment Characteristics	Recommended Type
Transmitter Frequency Measurement	Frequency — 100-200 MHz Accuracy — $\pm .00005\%$ or better	Any of the following items of Motorola Test Equipment: Model R1200 Series Service Monitor Model S1344 Series Frequency Counter & Deviation Meter Model R1025 Series Frequency Counter
Transmitter Deviation Measurement (Note 1)	Peak reading type for voice or sinusoidal wave; scales for accurate reading of ± 5 kHz deviation (and ± 1 kHz deviation for Private Line models)	Any of the following items of Motorola Test Equipment: Model R1200 Series Service Monitor Model S1344 Series Frequency Counter & Deviation Meter Model R2001 Series System Analyzer
Transmitter Power Output Measurement	100-200 MHz; 50 ohms: at least 0-125 watts. 50 ohms dummy load: at least 125 watts.	Motorola S1350 Series Wattmeter with appropriate element Motorola Model R2001 Series System Analyzer Motorola Model T1013 Series RF Load Resistor
RF Signal Generator for receiver testing (Note 2)	100-200 MHz; FM; high-stability ($\pm .0002\%$ or better); adjustable output 0 to 1000 microvolts	Motorola Model R1200 Series Service Monitor Motorola Model R2001 Series System Analyzer Motorola Model R1201 Series AM-FM Signal Generator Motorola Model R1020 Signal Generator
Audio Voltage Measurements	High impedance (10 megohm); dBm scale	Motorola Model S1053 Series Solid State AC Voltmeter
Audio Signal Generator for audio circuit testing in receiver and transmitter	Variable amplitude 0 to 1 volt; 1 kHz tone (300 to 3000 Hz preferred); sinusoidal wave	Motorola Model S1067 Series Solid State Audio Oscillator Motorola Model TEK-1 Tone Oscillator Motorola Model R1200 Series Service Monitor
DC Voltage Measurements, Resistance Measurements, RF Voltage Measurements	High impedance (11 megohm) DC multimeter	Motorola S1063 Series Solid State DC Multimeter with SLN6055A RF Probe Motorola Model R1001 Series Digital Multimeter Motorola R1024 Solid State DC Multimeter with RTL4103 R.F. Probe
Waveform Measurements	Oscilloscope:	Motorola Model R1029 Dual Trace Oscilloscope Audio Circuit Measurements: Motorola Model R1004 Series Oscilloscope RF Circuit Measurements: A very high quality instrument is required (at least 50 MHz bandwidth)
Tone <i>Private-Line</i> injection for PL decoder circuit measurements	<i>Private-Line</i> tone generator using <i>Vibrasender</i> resonant reed for frequency accuracy; or audio oscillator with frequency counter for accurate setting of oscillator.	Motorola Model S1333 Series Audio Synthesizer Motorola Model SLN6221 Series <i>Private-Line</i> Tone Generator
Digital <i>Private-Line</i> Encoder and Decoder measurements	Digital <i>Private-Line</i> Encoder and Decoder. Also test digital code plugs.	Motorola Model R1100 Series Code Synthesizer
Tuning Tool	Used for adjusting all tunable components during equipment alignment.	Motorola Part No. 66-83398A01 & 66-82977K01
Contact Removal Tool	Used to remove female wire terminals from metering cable connector	Motorola Part No. 66-84690C01

5. DISASSEMBLY AND SERVICE ACCESS

5.1 FRONT COVER AND LINE FUSE

5.1.1 Access to all circuitry on the *MSR 2000* station is gained through the front of the station. To remove the front door, turn the lock to the left with the key provided with the station. Pull the door panel back, and lift it up slightly to disengage the mounting flanges at the bottom.

5.1.2 The ac line fuse is located on the front side of the junction box at the right-hand side of the cabinet (refer to Figures 1 and 3). To replace the fuse, disconnect the line cord from the junction box. Unscrew the fuseholder cover from the fuseholder with a screwdriver.

5.2 POWER AMPLIFIER ACCESS AND REMOVAL

5.2.1 Access to Intermittent Duty Power Amplifier

5.2.1.1 To gain access to the power control board for servicing and metering, remove the 5 screws holding the cover over the power control board area of the PA casting (refer to Figure 1).

5.2.1.2 To gain access to the power amplifier board for servicing, remove the two black power amplifier securing screws. Swing the PA chassis assembly out and down (it is hinged at the bottom). Loosen 4 captive screws holding the cover over the power amplifier board (refer to Figure 2).

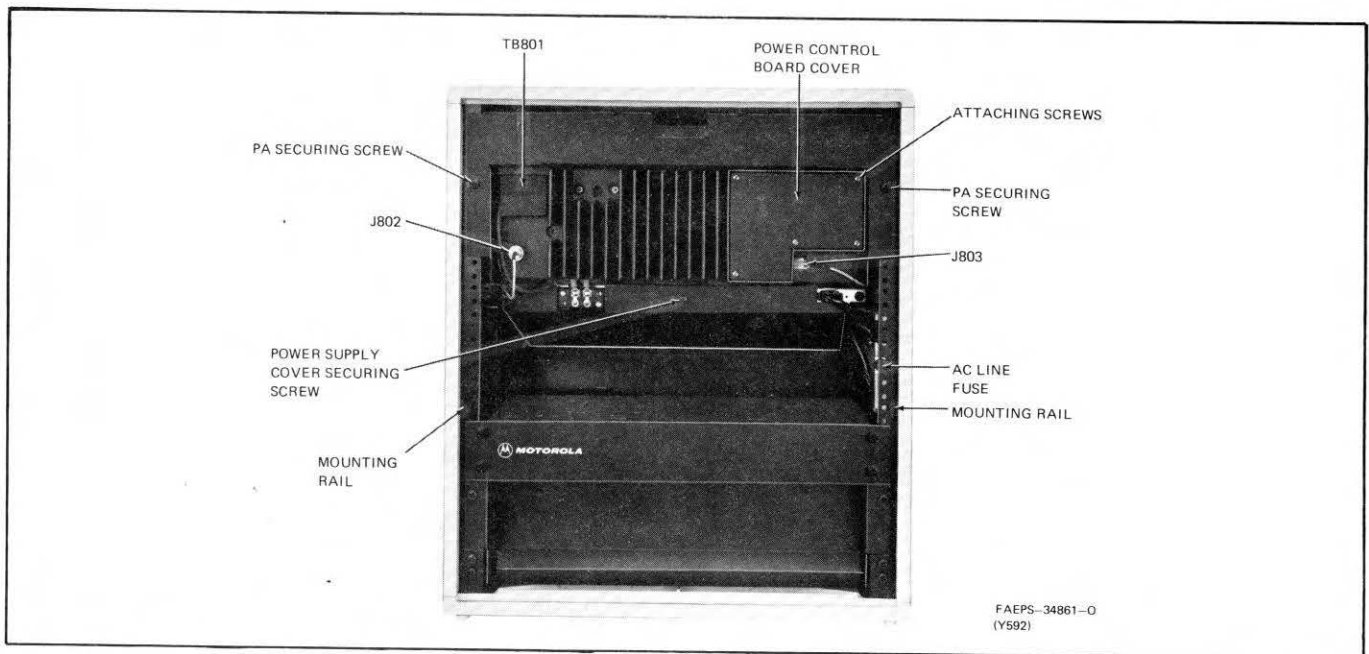

Figure 1. PA and Power Supply Detail of Intermittent Duty Station

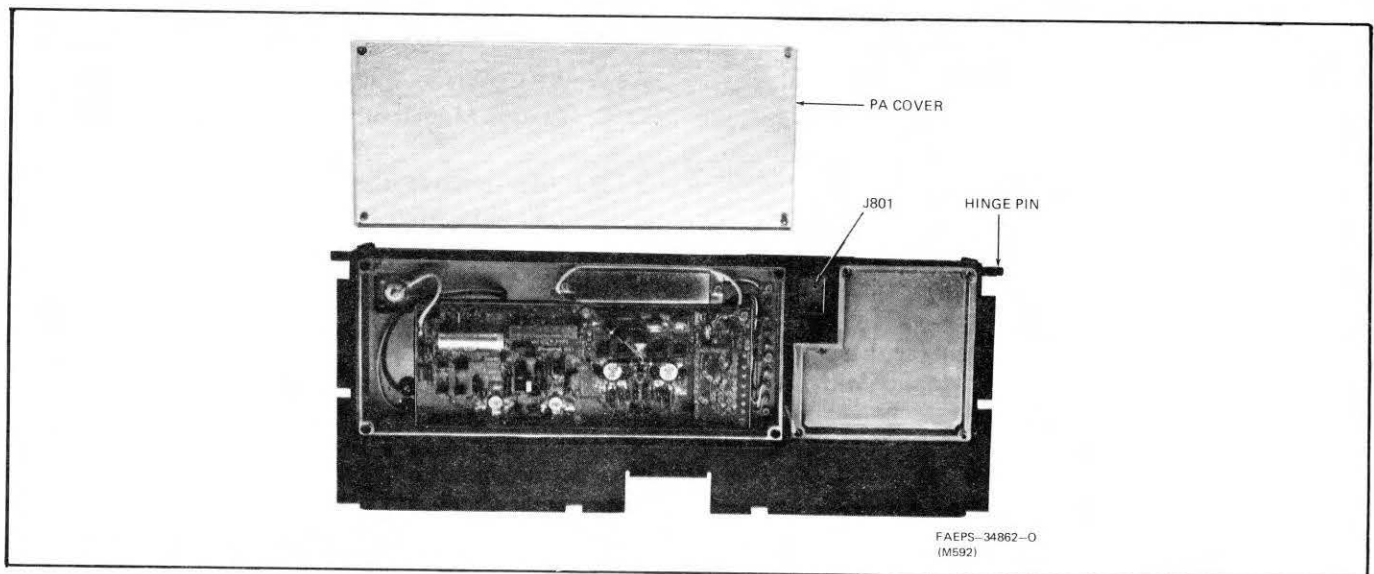

Figure 2. Power Amplifier Detail of Intermittent Duty Station

5.2.2 Access to Continuous Duty Power Amplifier

5.2.2.1 To gain access to the power amplifier boards for servicing and metering, remove the 4 black power amplifier securing screws. Swing the PA chassis assembly out and down (it is hinged at the bottom). Metering is accessible without removing any covers. Remove 12 screws holding the cover over the PA and power control board for servicing the PA (refer to Figures 3 and 4).

5.2.2.2 To gain access to the power control board for servicing, remove the 4 screws holding the power control bracket (refer to Figure 4).

5.2.3 Removal of Power Amplifier

The entire power amplifier chassis may be removed, if desired, for substitution or for access to the power supply. Perform the following steps:

Step 1. Disconnect the two coaxial connectors from J802 and J803 on the PA chassis. Disconnect the two power wires (red and black) from TB601 at the power supply.

Step 2. Swing the power amplifier chassis into the down position as explained above. Disconnect P801, the three-wire connector, from J801 on the PA chassis.

Step 3. With both hands under the PA chassis, lift the chassis approximately 1/2-inch and pull it toward you. Raise the left side of the PA chassis until the hinge pins clear the mounting rails, and pull the PA chassis out of the station cabinet.

Step 4. Installation is the reverse of the above.

5.3 RF CONTROL CHASSIS ACCESS AND REMOVAL (Refer to Figures 1 and 3.)

5.3.1 The rf control chassis may be opened or lowered for service access. The control module cover panel must be removed for access to control and audio modules, and the chassis may tilted out for access to the back of the backplane interconnect board and the rf boards.

5.3.2 To remove the control module cover panel, pull outward on the lip at the top of the panel. The panel snaps and pivots outward. The control and audio modules may be removed for servicing with a Motorola part no. 66-83574F01 Card Puller, supplied with the station.

5.3.3 To tilt out the rf control chassis, remove two black Phillips head screws securing the rf control chassis in place. Pull the chassis out from the top and tilt downward. In this position, all exciter and receiver

metering connections are accessible, and the backplane interconnect board may be serviced.

5.3.4 To remove the rf control chassis, tilt out the chassis to the service position and perform the following steps:

Step 1. Mark and disconnect all wiring from the terminal screws on the backplane interconnect board.

Step 2. Remove two screws securing each rf coaxial connector to the exciter and receiver positions.

Step 3. Disconnect main wiring harness connector P1 from J1 on the backplane interconnect board.

Step 4. Cut all wire ties and remove any cable clamps securing cables to the rf-control chassis.

Step 5. Lift up the rf control chassis approximately 1/2 inch and pull toward you. Raise the left-hand end of the chassis until the hinge pins clear the mounting rails, and pull the chassis out of the station housing.

Step 6. Installation is the reverse of the above. Be sure to replace all wire ties and cable clamps in the position originally supplied.

5.4 EXCITER AND RECEIVER ACCESS AND REMOVAL

5.4.1 RF Cover — Base Station Models

To remove the rf cover to gain access to the exciter and receiver circuit boards, remove 4 Phillips head screws (with plastic covers) as shown in Figure 5. Slide the cover out slightly and lift up while pulling toward you. Pull the cover out of the station cabinet. Tilt out the rf control chassis as explained in paragraph 5.3 for easy access to the exciter and receiver circuit boards. The exciter and receiver circuit boards may be removed by pulling the ejector handles and then pulling the boards out of the chassis.

5.4.2 RF Covers — Fully Optionable Repeater Station Models or Stations With Shield Option

5.4.2.1 To remove the front rf cover, remove 4 Phillips head screws (with plastic covers) as shown in Figures 6 and 7. The exciter and receiver boards may now be removed by pulling the ejector handles and then pulling the boards out of the chassis.

5.4.2.2 To remove the top rf cover (front rf cover must be removed first), remove two black Phillips head screws securing the rf control chassis in place. Tilt the chassis out from the top by pulling toward you. Loosen 15 hex-head screws holding the cover in place, and slide the cover down so that the large end of the keyhole slots clear the securing screws. Lift the panel away from the chassis.

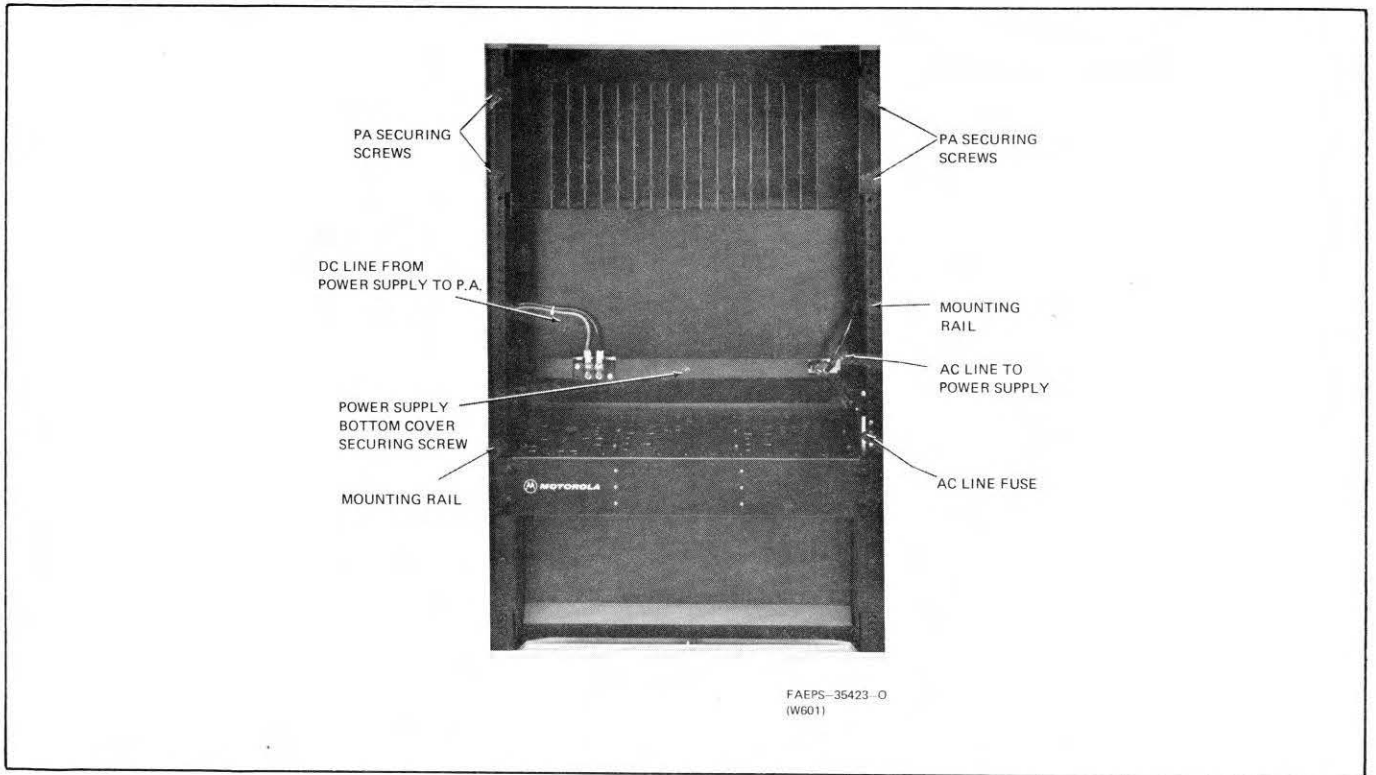

Figure 3. PA and Power Supply Detail of Continuous Duty Station

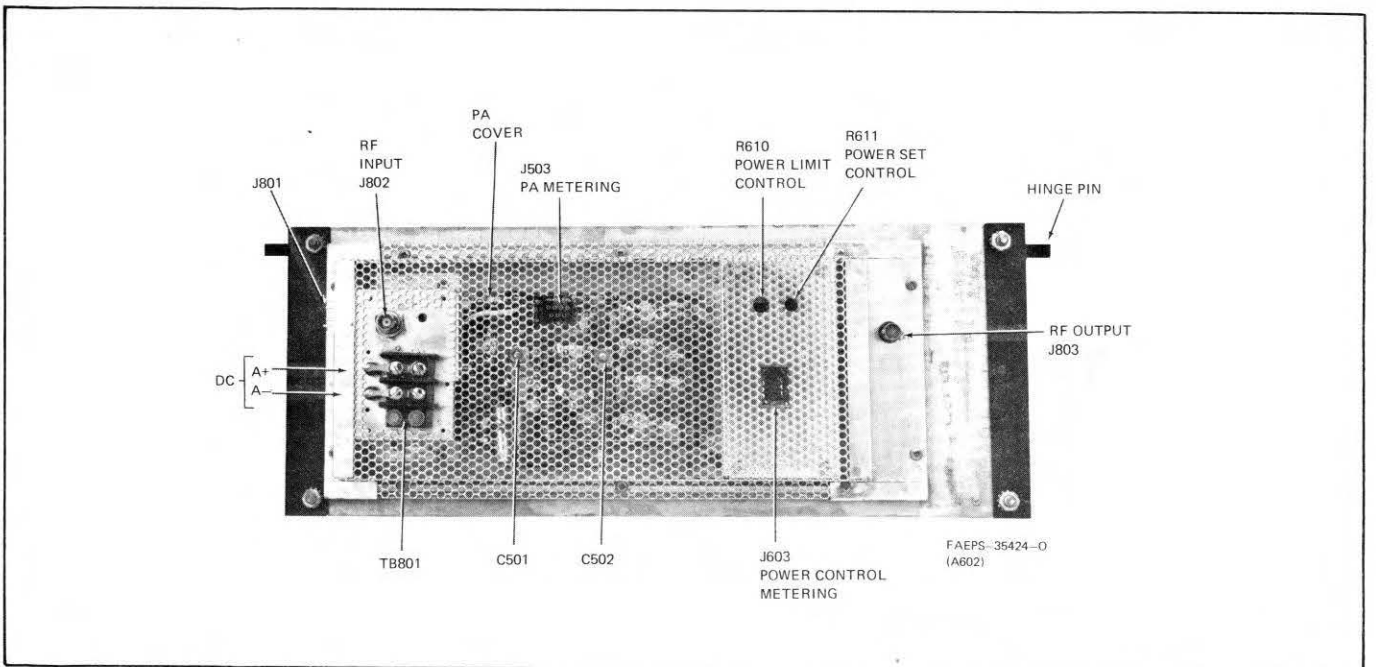

Figure 4. Power Amplifier Detail of Continuous Duty Station

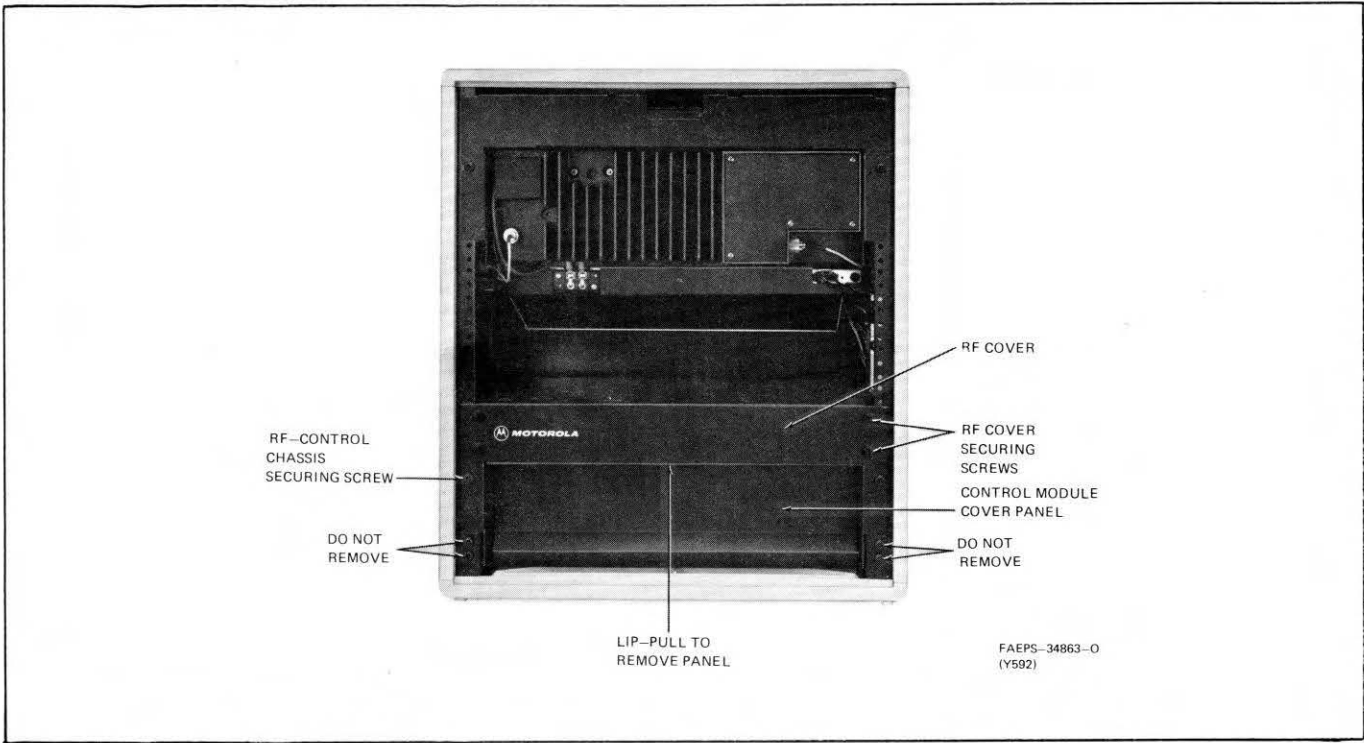

Figure 5. Basic Intermittent Duty Station Chassis Access

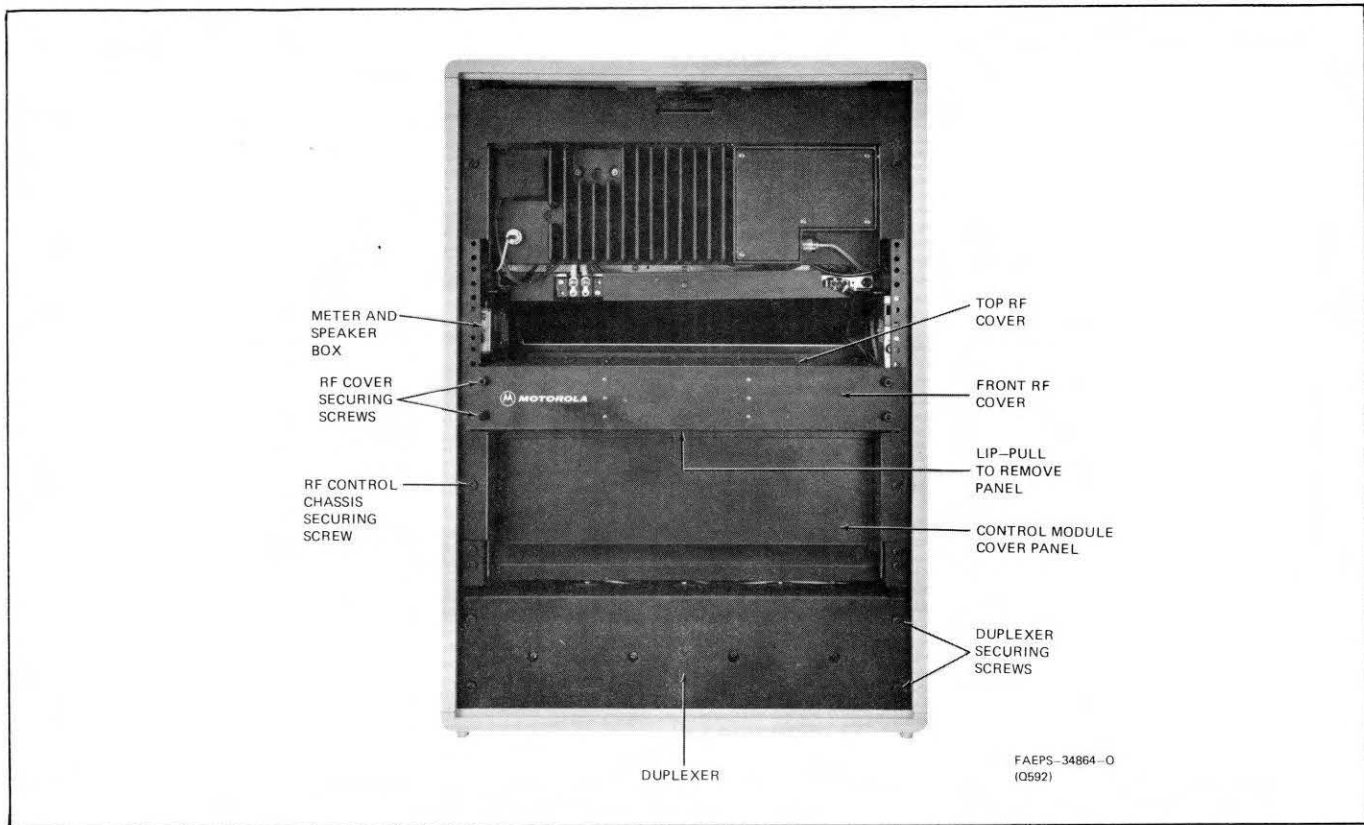

Figure 6. Fully Optionable Intermittent Duty Station Chassis Access

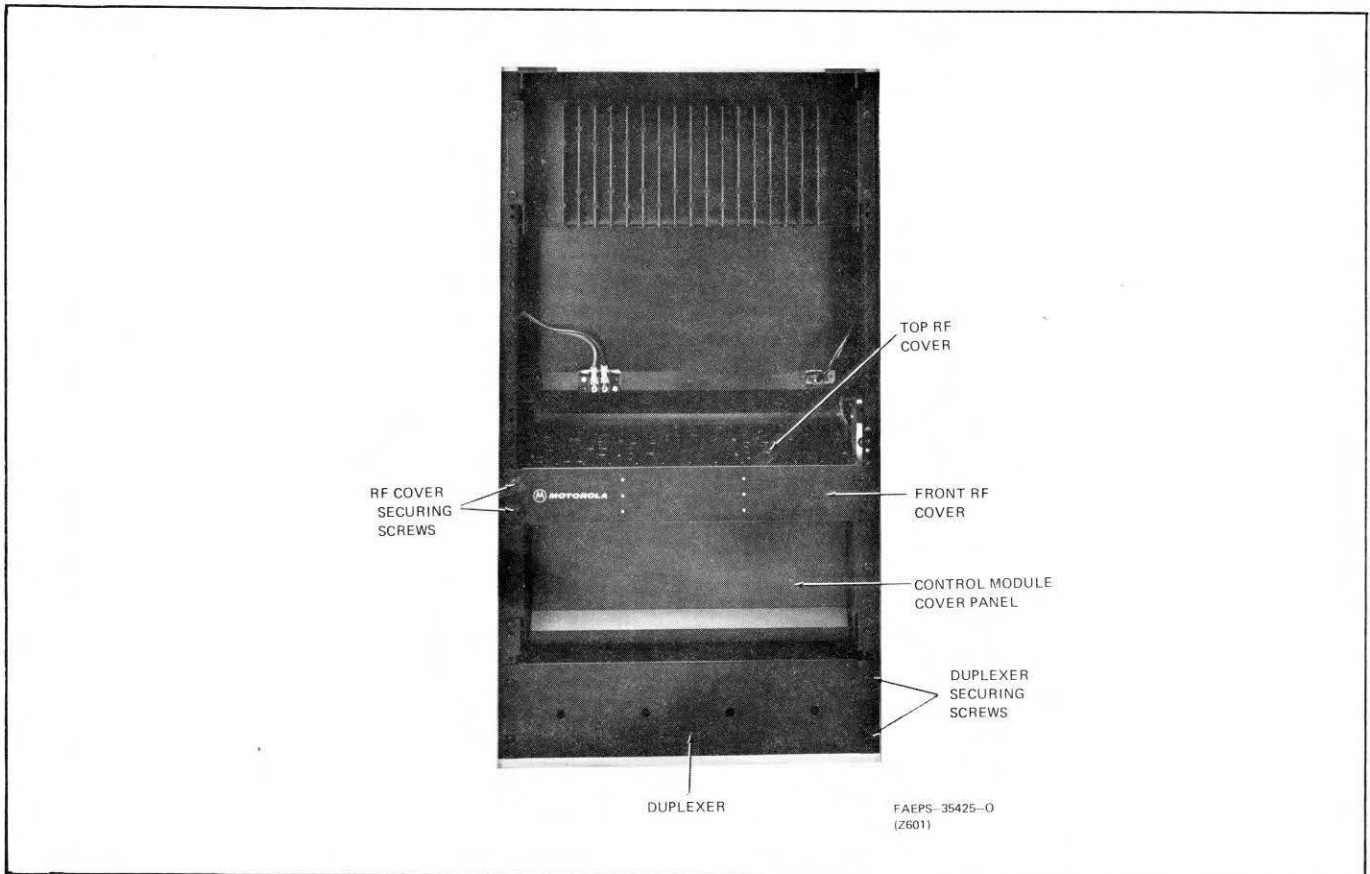

Figure 7. Fully Optionable Continuous Duty Station Chassis Access

5.5 SPEAKER INTERCOM WITH SPEAKER AND DC METERING CHASSIS ACCESS

Instructions for use of the station service accessory boxes are given in the Accessories section of this manual. The service box is mounted to the left side mounting rails of the station, inside the station housing. For ease in servicing, the box may be removed from the station cabinet. Lift the box up to clear the keyhole slots in the mounting brackets, and slide the box out of the cabinet. When finished, replace the box into the station cabinet. It is not necessary to tighten the mounting screws, once the station is permanently installed.

5.6 DUPLEXER REMOVAL

Instructions for servicing and adjusting the duplexer are provided in the Duplexer instruction section in this manual. To remove the duplexer from the MSR 2000 station cabinet, remove four black Phillips-head screws securing the duplexer to the mounting rails. Pull the duplexer partially out of the cabinet, until the rf connectors are accessible. Disconnect three UHF-type connectors, and remove the duplexer from the station cabinet. Installation is the reverse of this procedure.

5.7 POWER SUPPLY ACCESS

5.7.1 The power supply may usually be serviced without removing it from the cabinet. If removal is necessary, refer to the Power Supply instruction section of this manual for the recommended removal procedure.

5.7.2 To gain access to the power supply chassis, remove the power supply cover plate located under the PA chassis. It is retained by a single screw in the upper center of the cover (refer to Figures 1 and 3). For continuous duty stations, remove the top power supply cover plate located directly behind the PA chassis. It is retained by two screws located in the lower left and right hand corners. It may also be necessary to remove the PA chassis from the station housing, refer to the Power Amplifier Removal and Access paragraph in this section.

5.8 TWO-RECEIVER COUPLER REMOVAL

The two-receiver coupler is located along the left-hand side of the station housing, and is accessible only with the rf control chassis removed from the station housing. Refer to the RF Control Chassis Access and

Removal paragraph for the correct procedure. To remove the two-receiver coupler from the station housing, remove 2 screws securing it to the mounting rails. Lift the two-receiver coupler away from the mounting rails and disconnect the 3 phono-type rf connectors from the coupler plate.

5.9 JUNCTION BOX ACCESS

The back side of the junction box (TRN5350A or TRN5351A) can be reached by removing only the locking station cover. The line cord connection panel may be removed from the outside of the station housing by removing 2 screws holding the panel in place. To remove the entire junction box assembly from the station, remove the station wraparound cover following the procedure in the Wraparound Cover Removal paragraph. Remove 4 screws holding the junction box to the mounting rails.

5.10 WRAPAROUND COVER REMOVAL

The station wraparound cover is secured in place by the top and bottom covers of the station. To remove the station wraparound cover, perform the following steps:

Step 1. Remove six TORX® -type (T45) screws holding the top cover in place, using a Motorola part number 66-84071N02 TORX® wrench (supplied with station). Remove the top cover.

Step 2. Lift the wraparound cover approximately 1/2-inch up and out of the bottom cover channel.

Step 3. Spread the sides of the wraparound cover enough to clear the mounting rails of the station housing, and slide the housing toward the back of the station and remove.

Step 4. Installation is the reverse of the above.

6. MECHANICAL PARTS IDENTIFICATION

The mechanical parts identification photos are used to identify certain mechanical parts that are not identified elsewhere in the manual.

TORX® is a registered trademark of Camcar Division of Textron Inc.

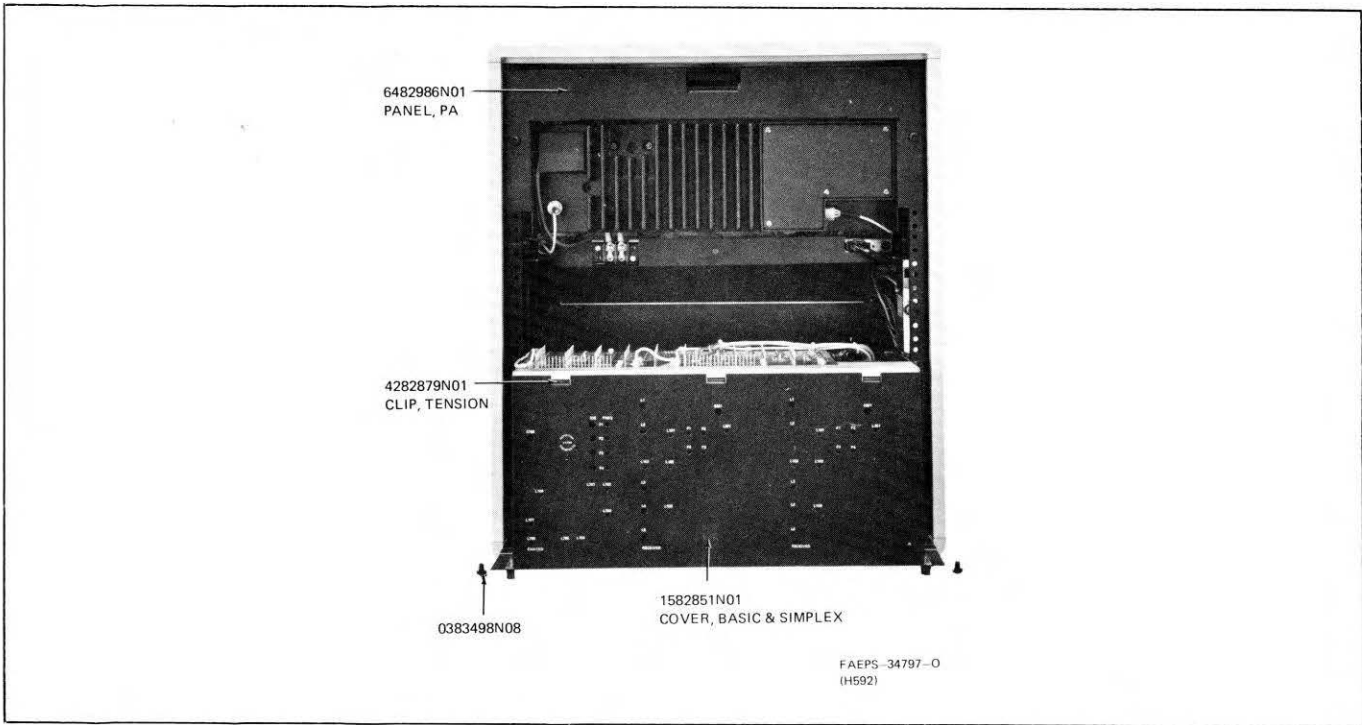
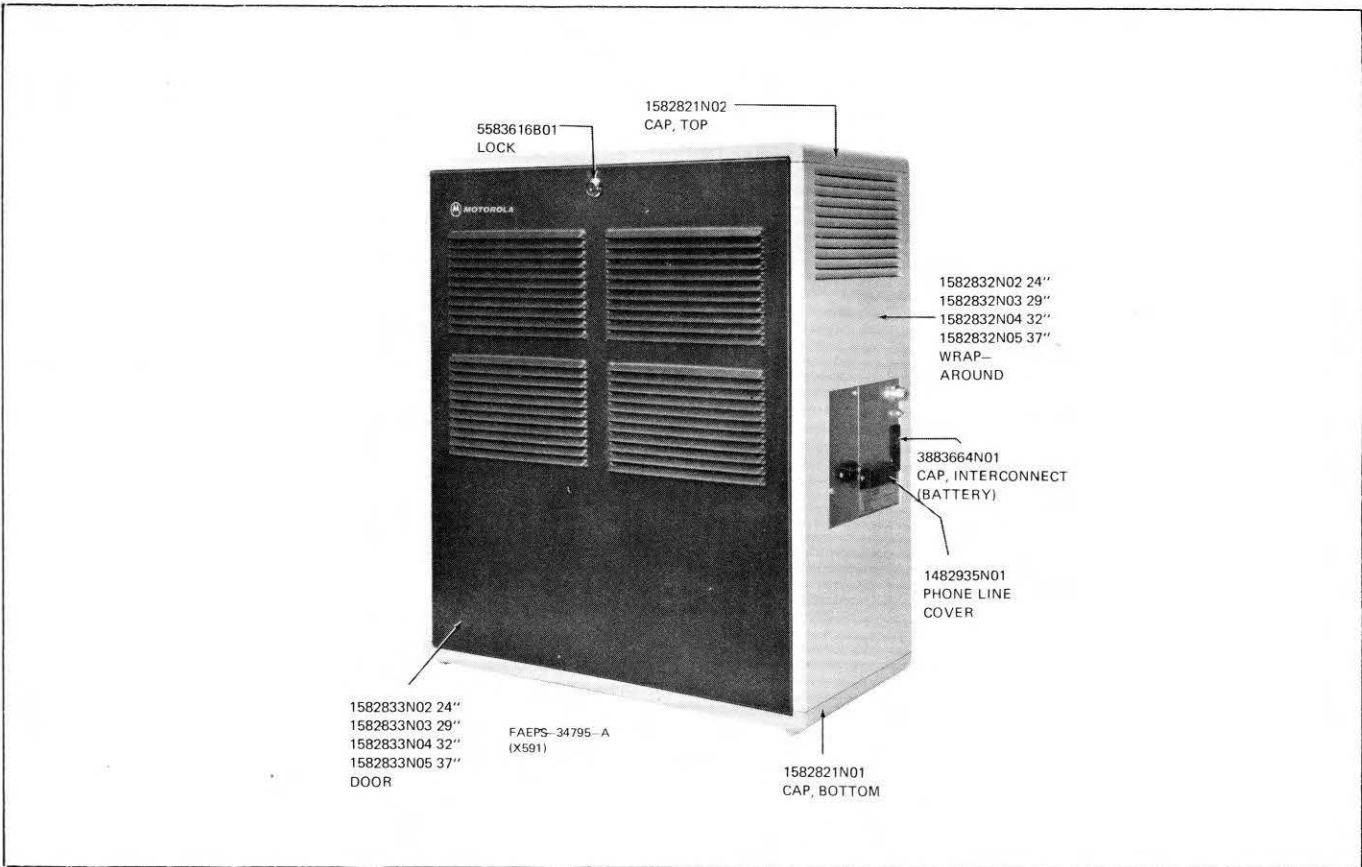

*MSR 2000 Basic Model Station
Mechanical Parts Identification
Motorola No. PEPS-34951-A
(Sheet 1 of 4)
11/15/82 - V & G*

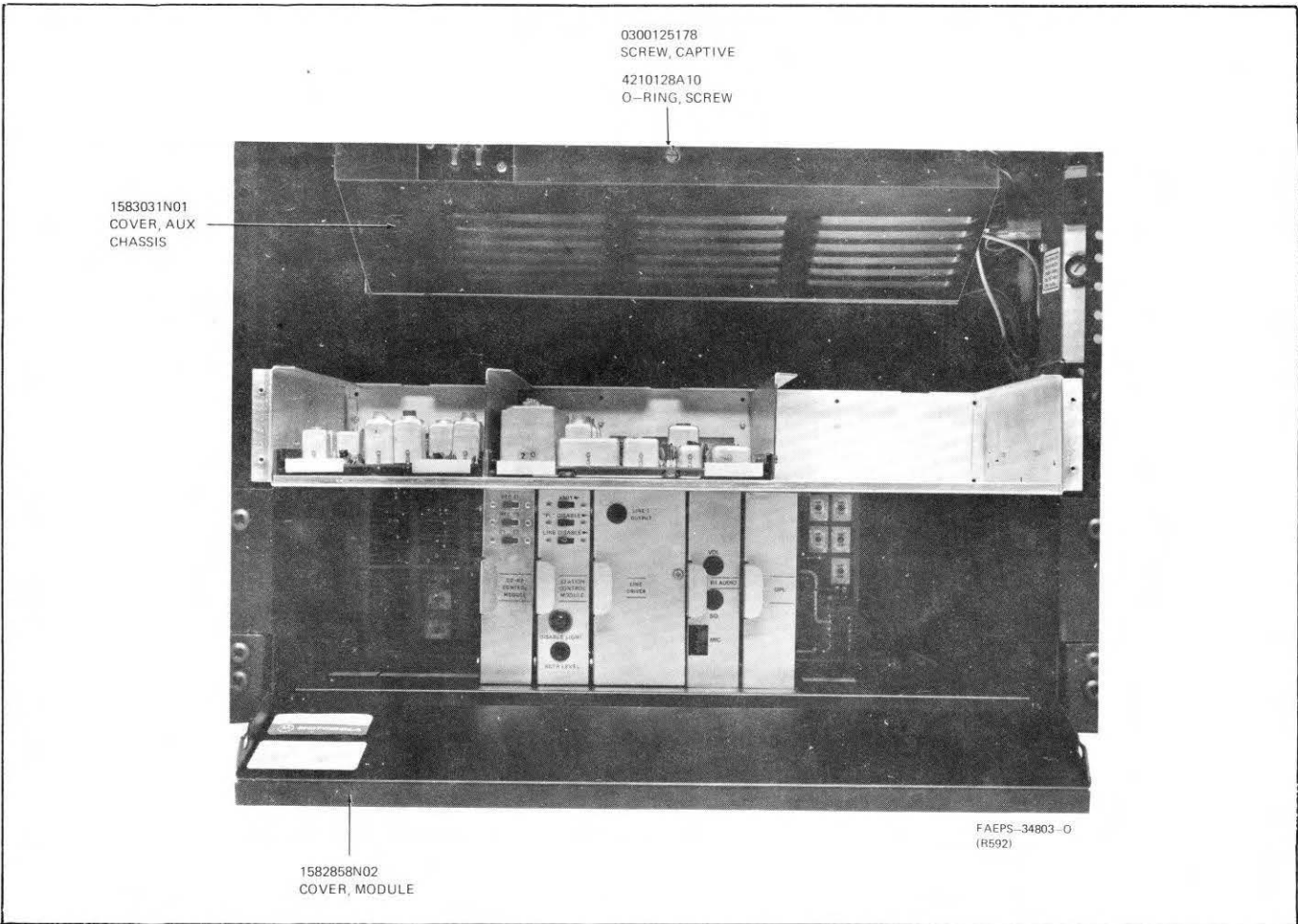
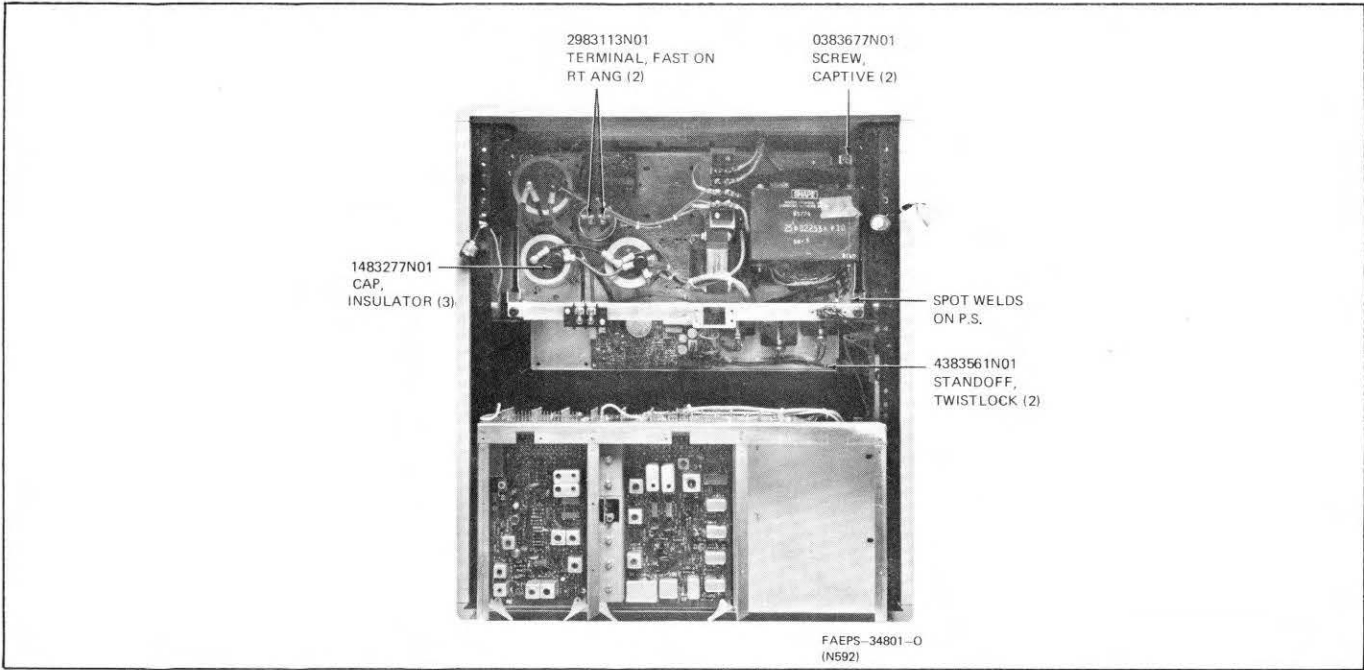

MSR 2000 Basic Model Station
Mechanical Parts Identification
 Motorola No. **PEPS-34951-A**
 (Sheet 2 of 4)
 11/15/82 - V & G

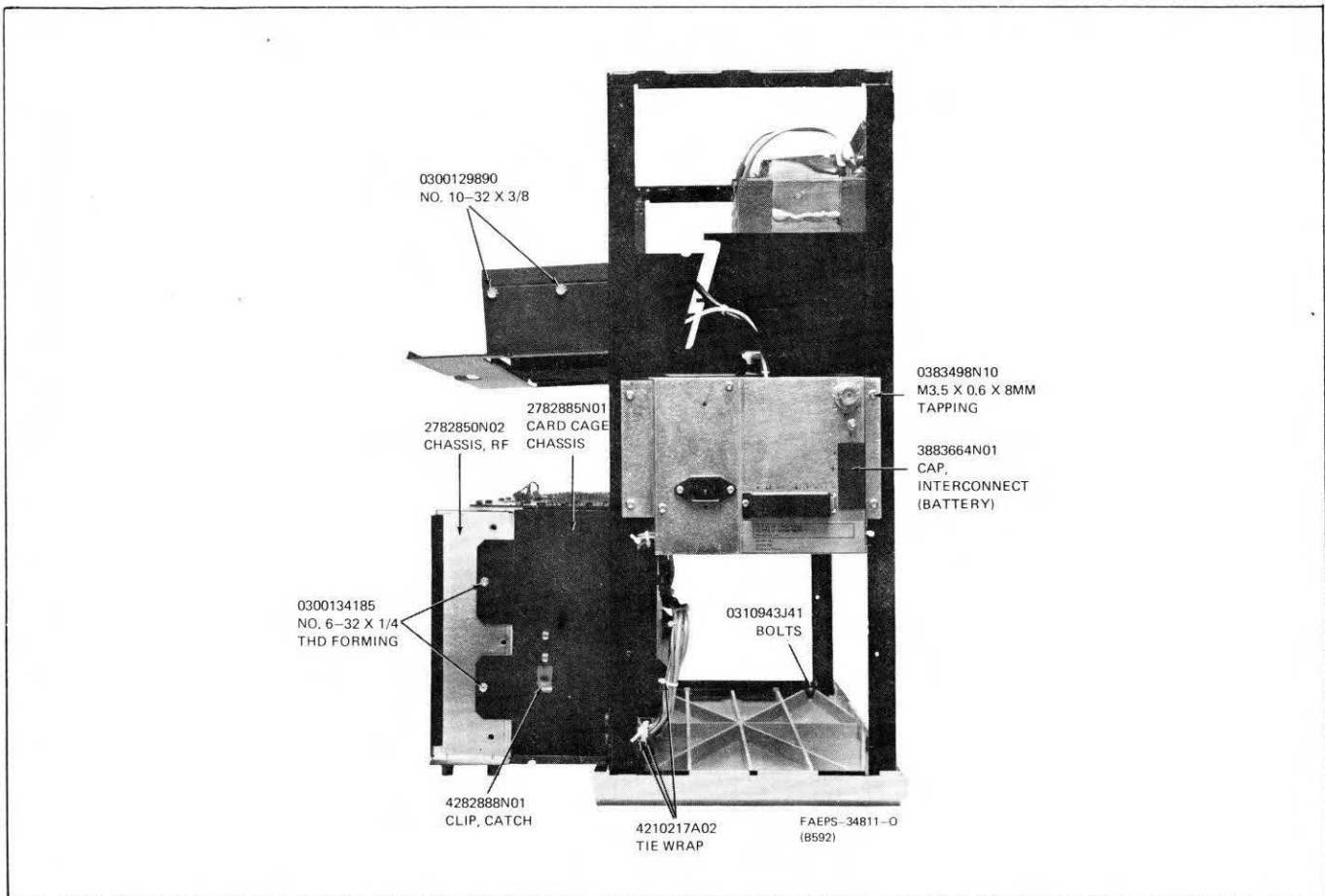
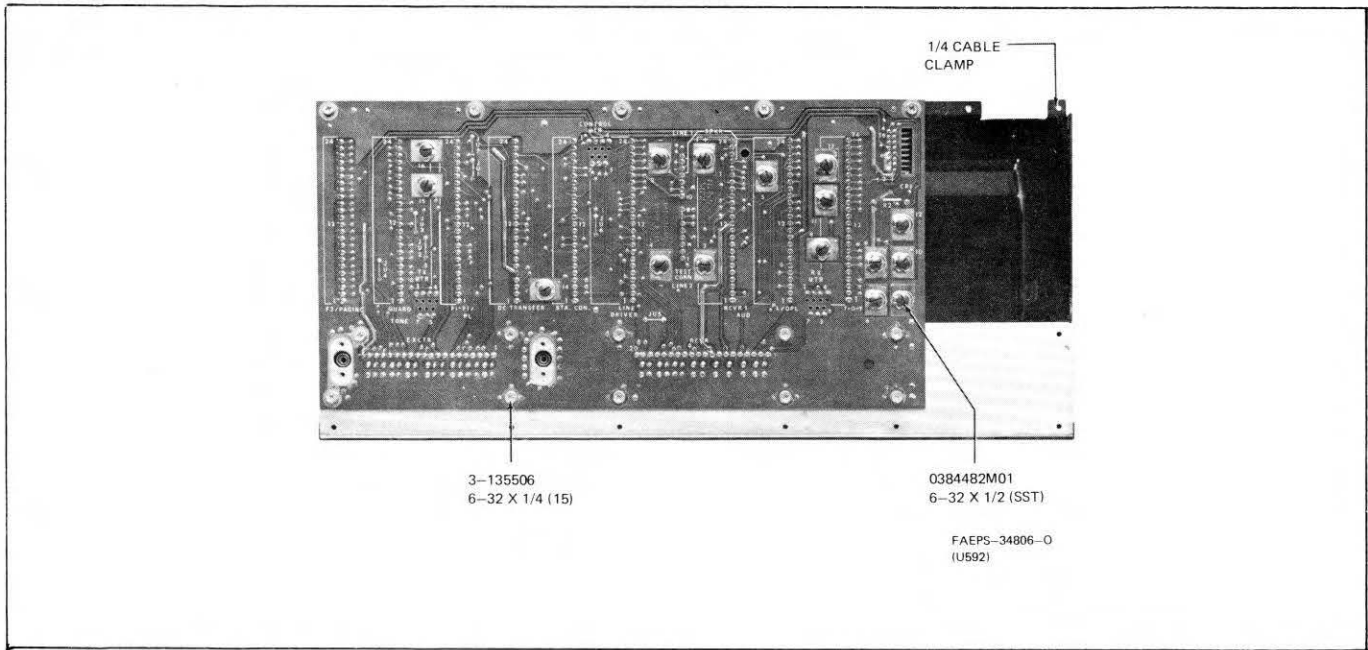

STATION MAINTENANCE

*MSR 2000 Basic Model Station
Mechanical Parts Identification
Motorola No. PEPS-34951-A
(Sheet 3 of 4)
11/15/82 - V & G*

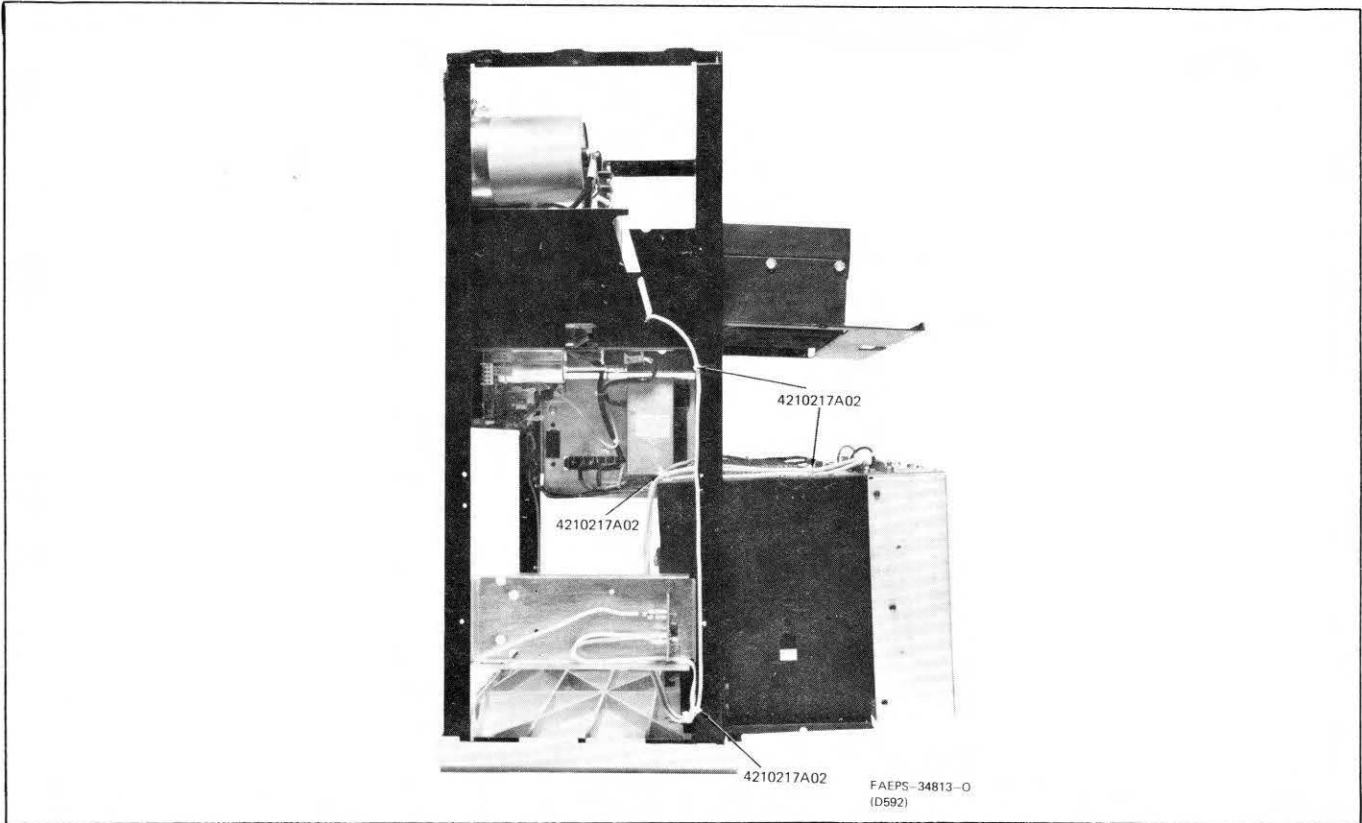
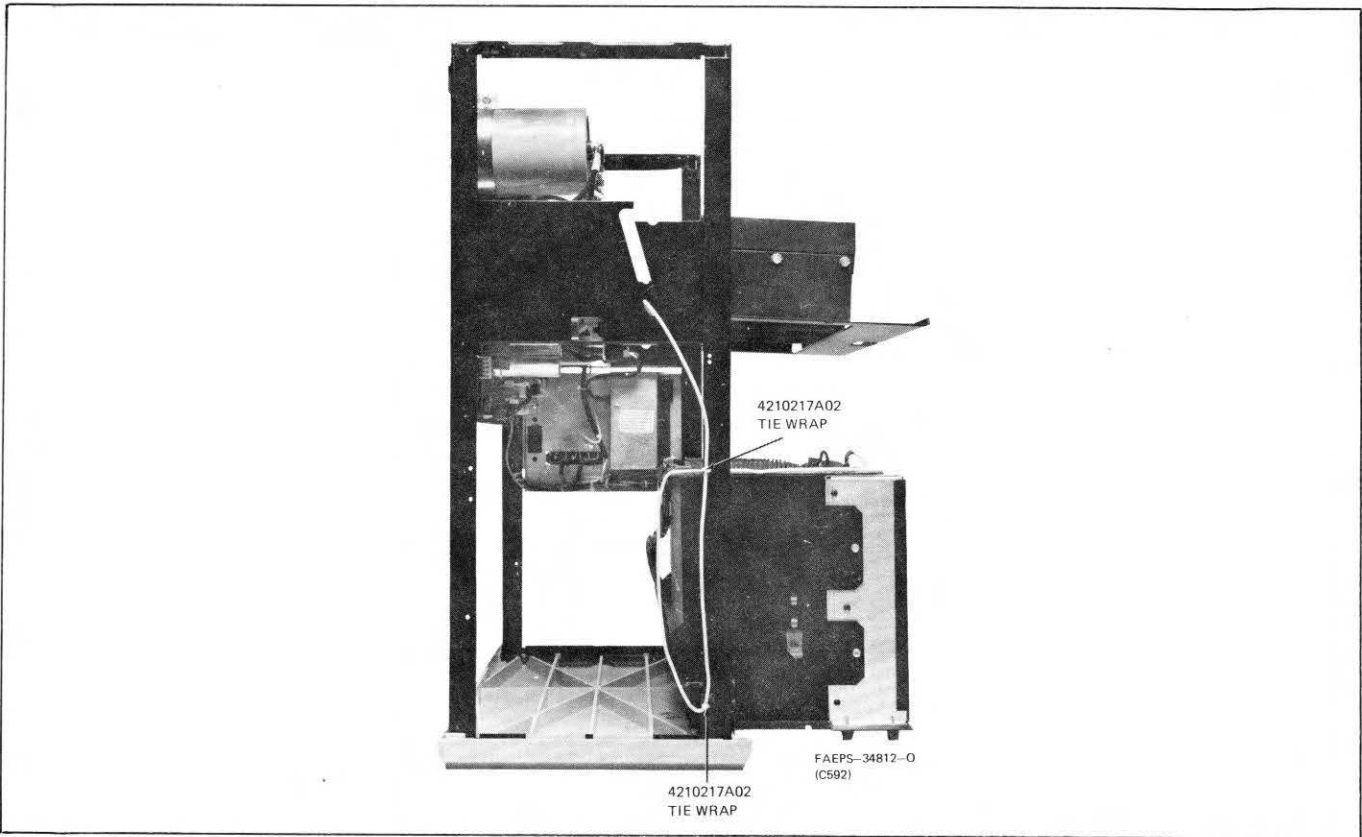

*MSR 2000 Basic Model Station
Mechanical Parts Identification
Motorola No. PEPS-34951-A
(Sheet 4 of 4)
11/15/82 - V & G*

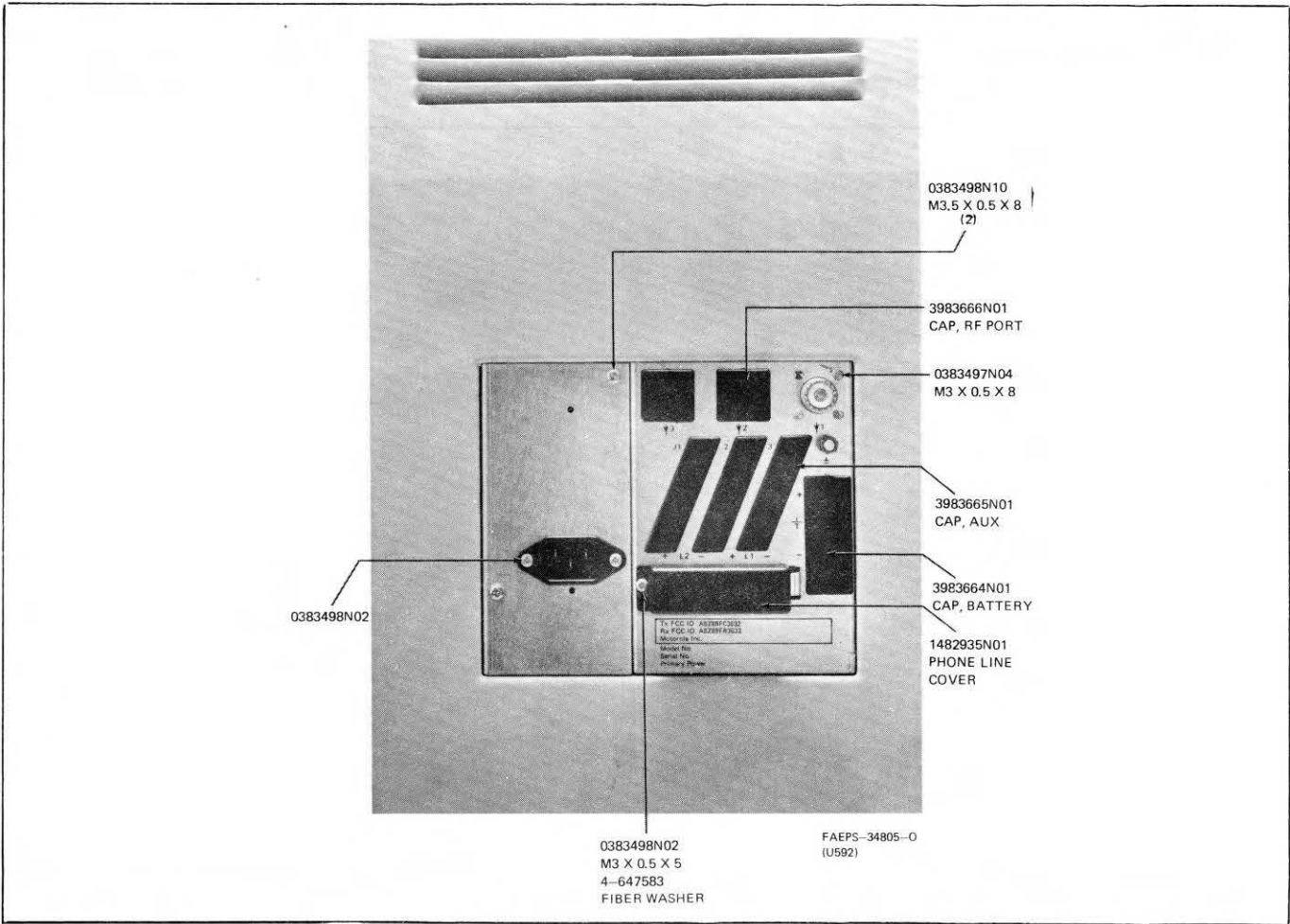
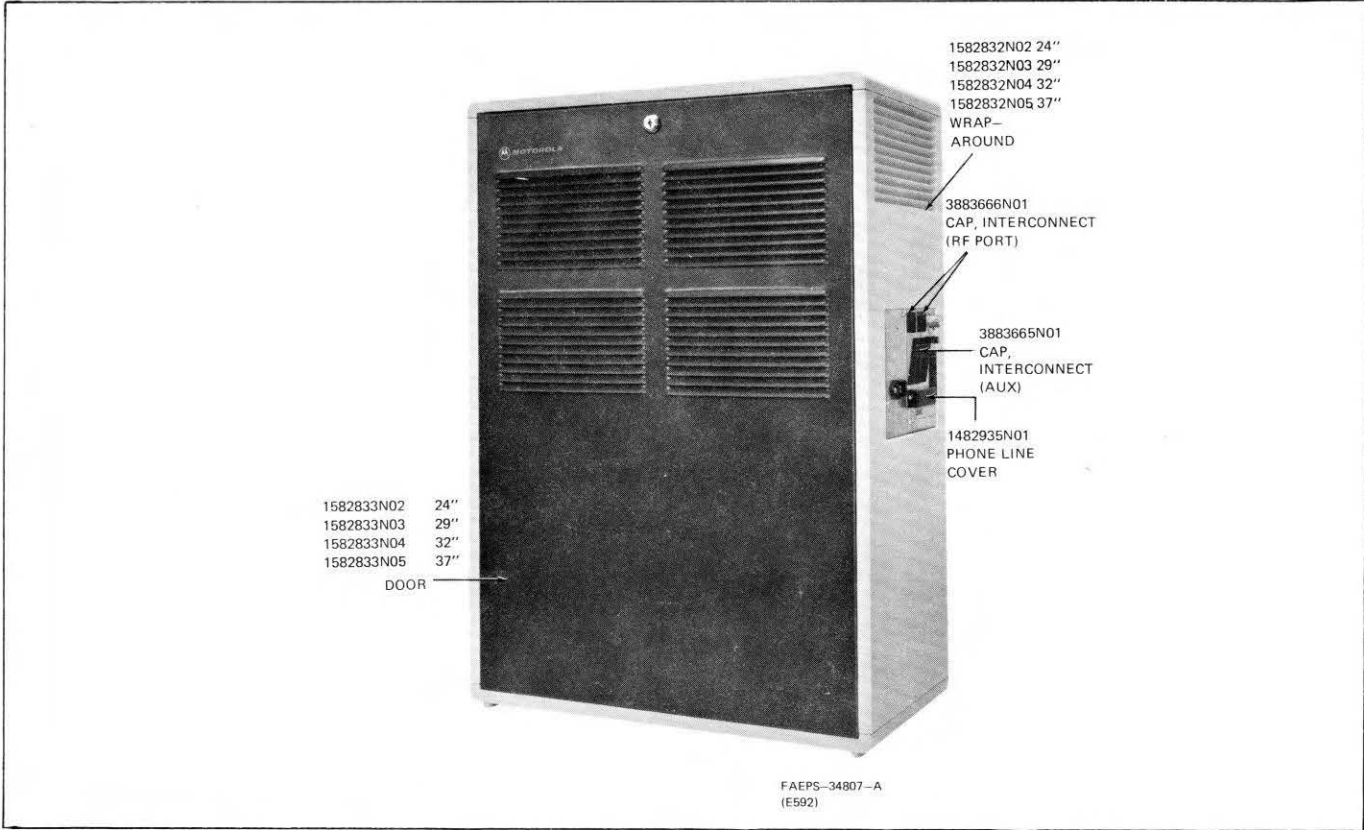

STATION MAINTENANCE

*MSR 2000 Fully Optionable Model Station
 Mechanical Parts Identification
 Motorola No. PEPS-34952-A
 (Sheet 1 of 4)
 11/15/82 - V & G*

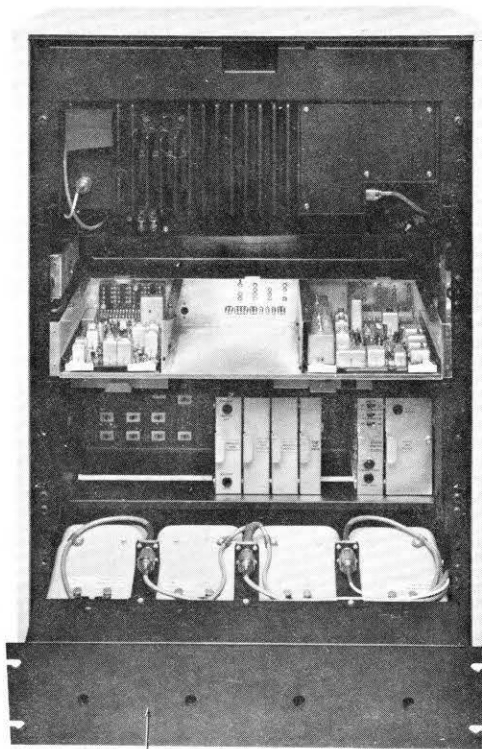

2782934N01
CHASSIS,
DUPLXER

FAEPS-34798-O
(I592)

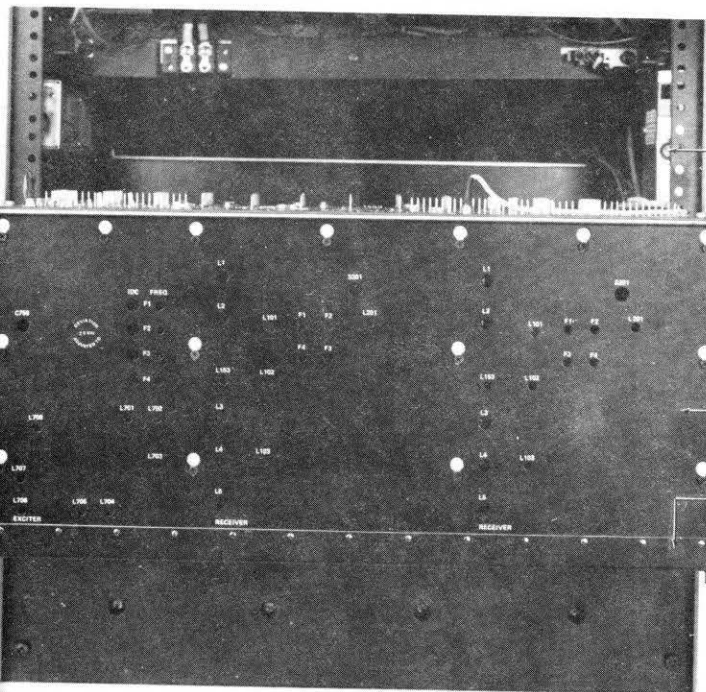

1582891N01
FUSE HOLDER
& NUT
3882892N01
FUSE HOLDER CAP

0300136932
NO. 4-40 X 3/8
PHL HEX (15)

1582852N01
COVER, TOP

1582853N01
COVER,
FRONT

4283123F01 (4)
PLASTIC RETAINER
0583124F01 (4)
EYELET NO. 6
0300138430 (4)
NO. 4-24 X 3/8

FAEPS-34799-O
(K592)

MSR 2000 Fully Optionable Model Station
Mechanical Parts Identification
Motorola No. PEPS-34952-A
(Sheet 2 of 4)
11/15/82 - V & G

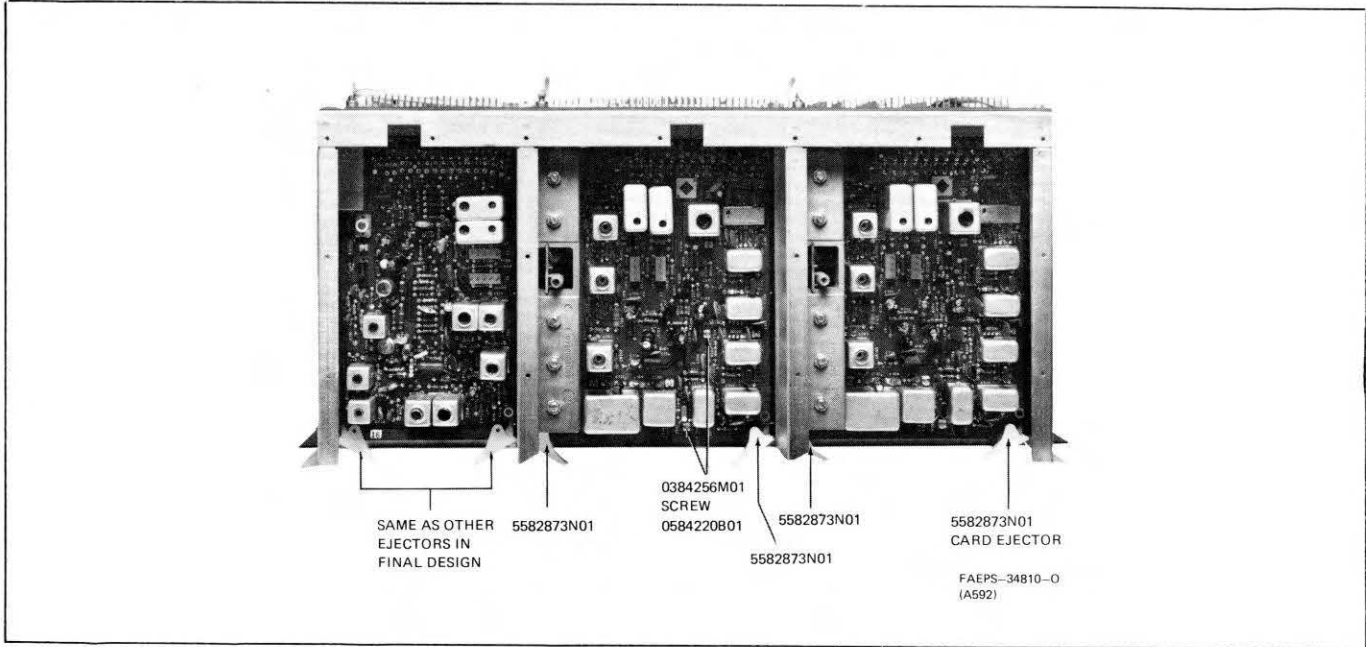
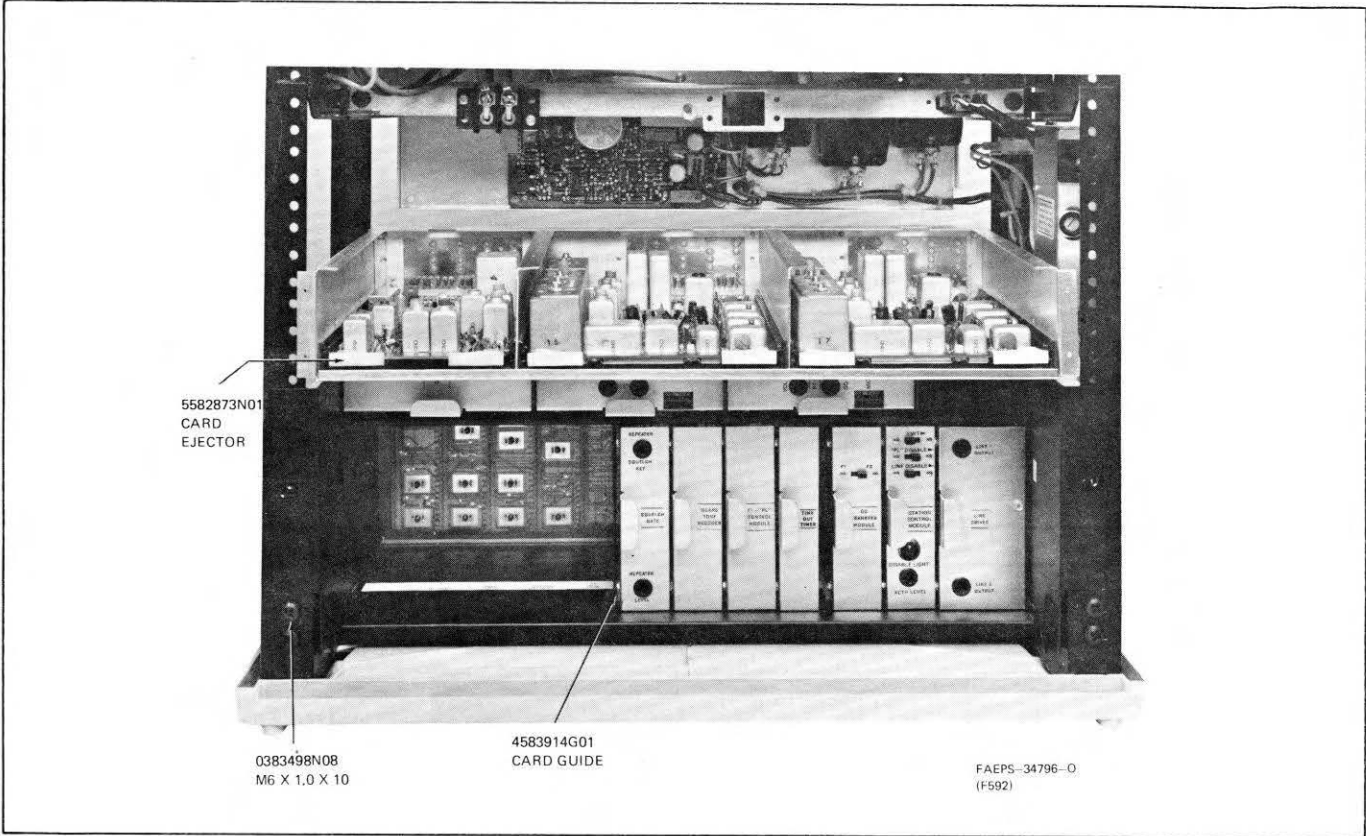

STATION MAINTENANCE

*MSR 2000 Fully Optionable Model Station
Mechanical Parts Identification
Motorola No. PEPS-34952-A
(Sheet 3 of 4)
11/15/82 · V & G*

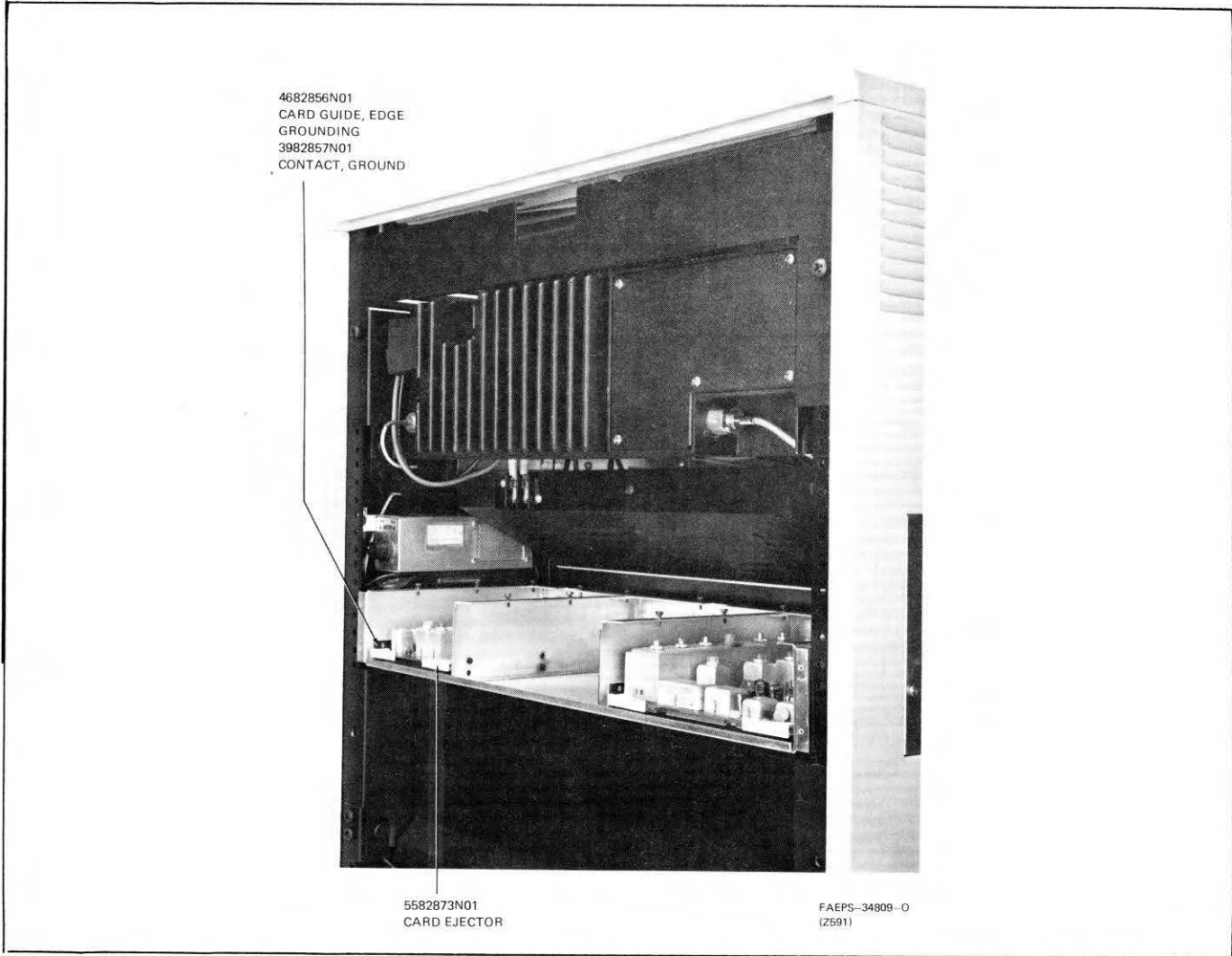
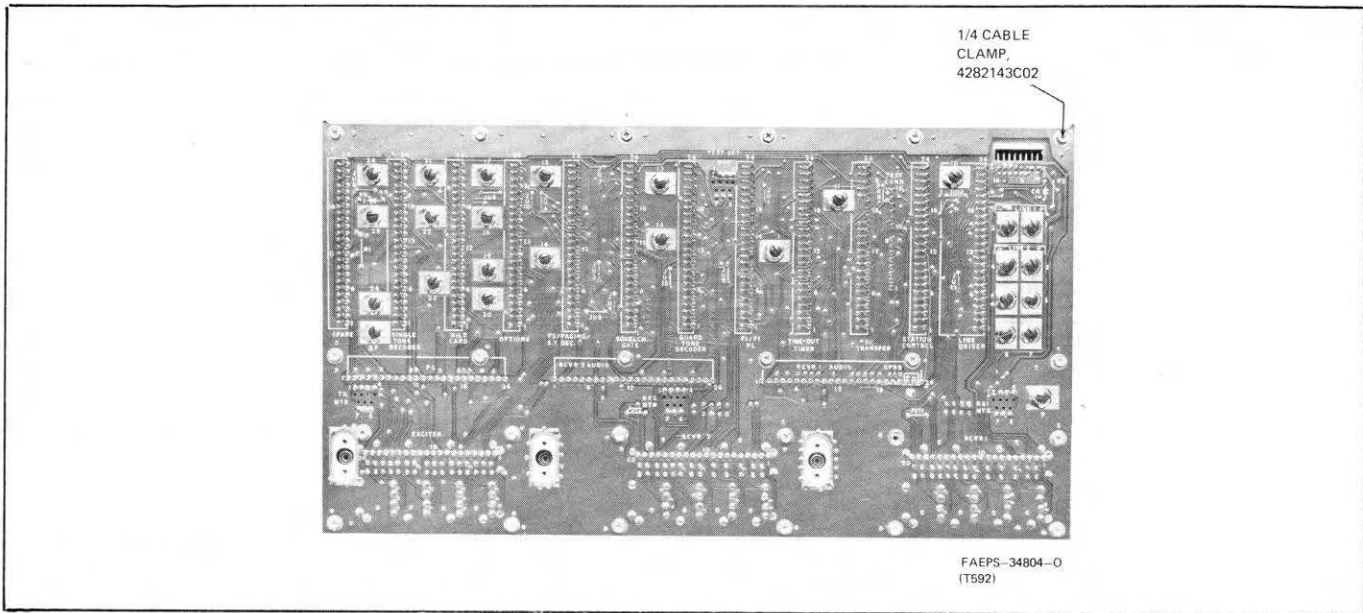

*MSR 2000 Fully Optionable Model Station
Mechanical Parts Identification
Motorola No. PEPS-34952-A
(Sheet 4 of 4)
11/15/82 - V & G*

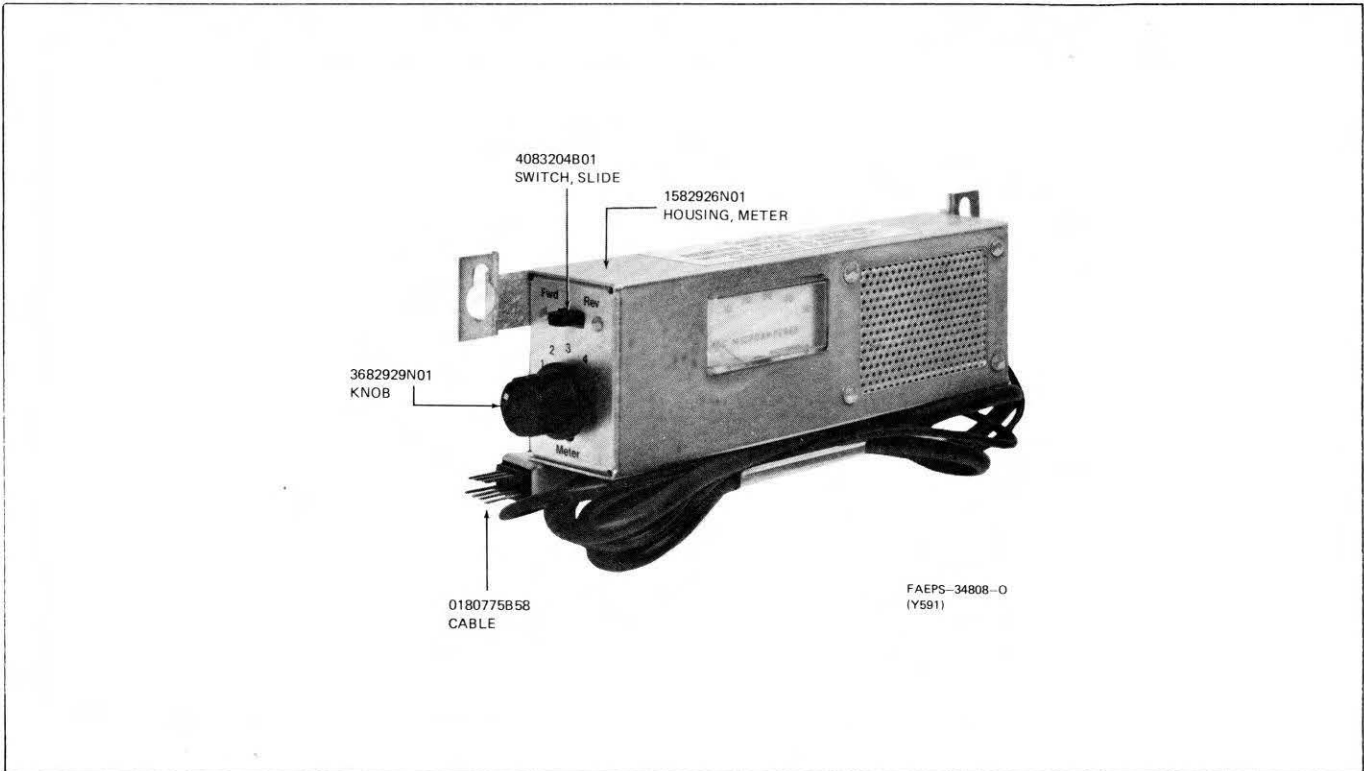

*MSR 2000 Base Station
Service Intercom with Speaker and
DC Metering Chassis Mechanical Parts Identification
Motorola No. FAEPS-34808-O
11/15/82 - V & G*

INTERMITTENT DUTY POWER AMPLIFIER

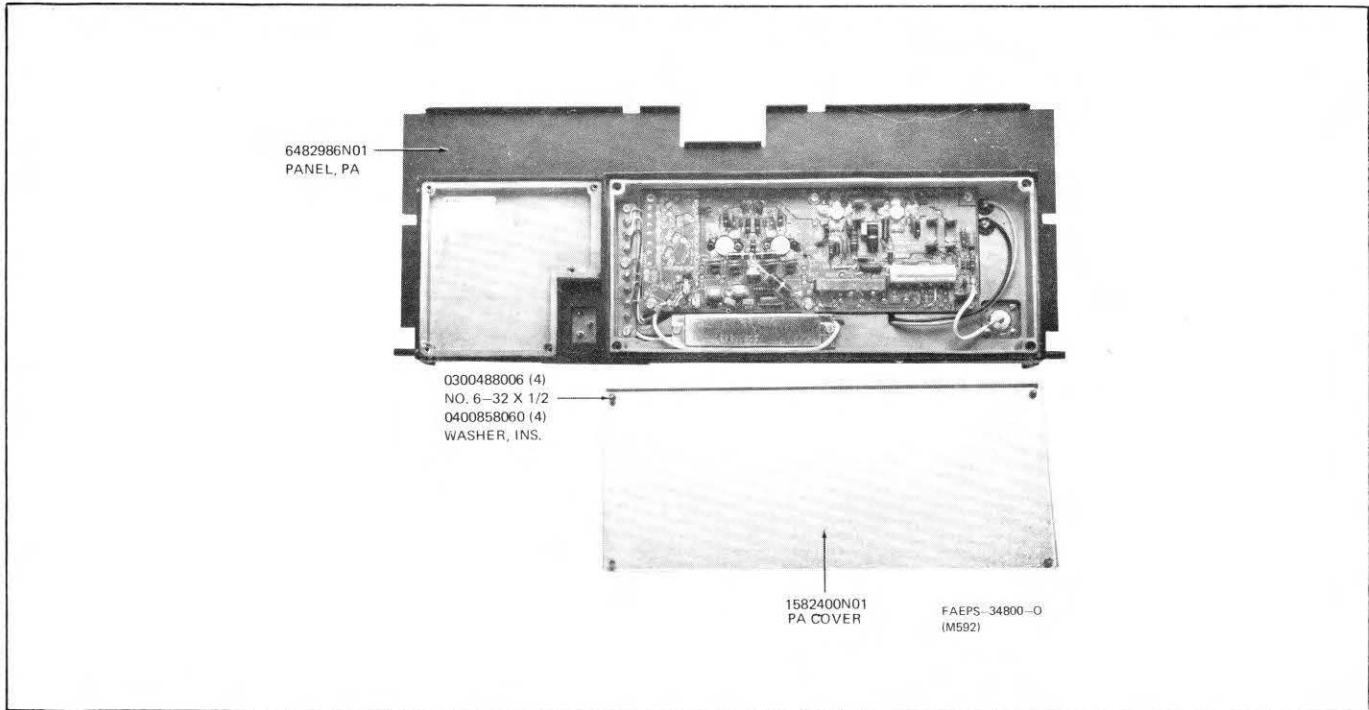

CONTINUOUS DUTY POWER AMPLIFIER

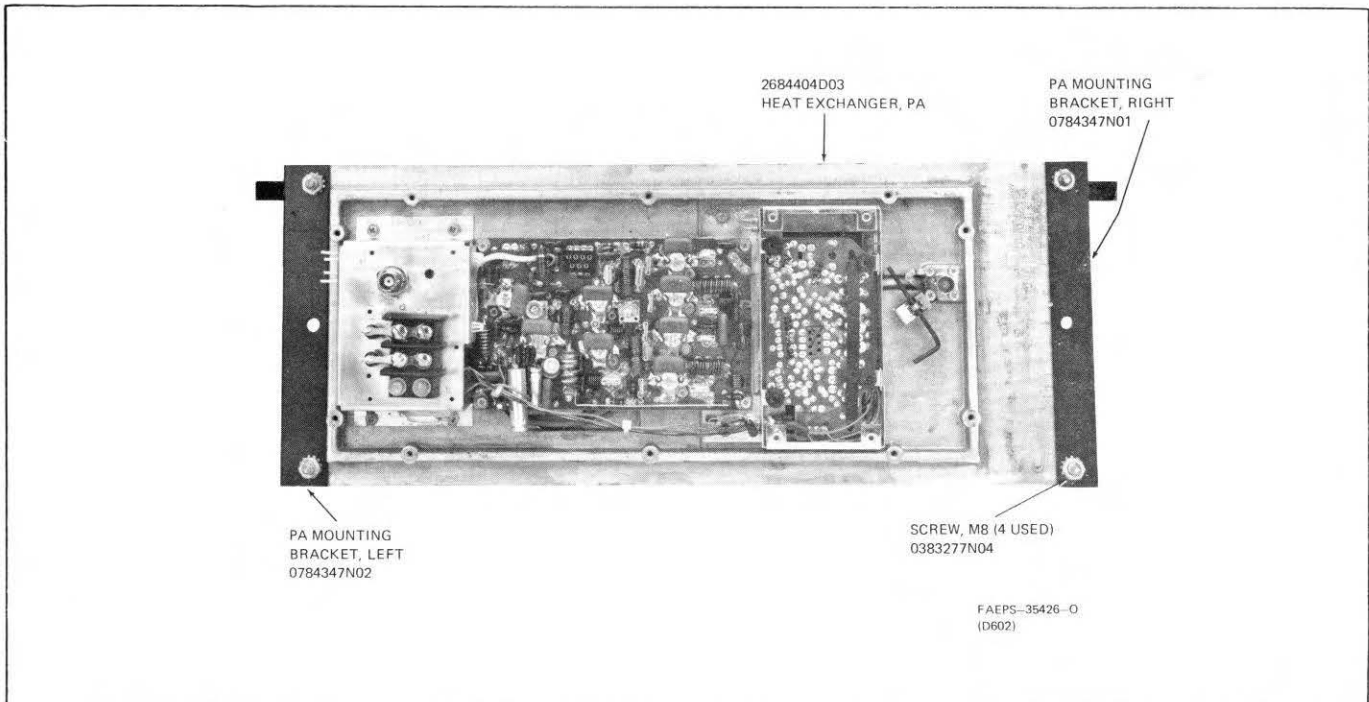

*MSR 2000 Base Station
Power Amplifier Mechanical Parts Identification
Motorola No. PEPS-35510-O
11/15/82 - V & G*

parts list

TRN5423A 24" Cabinet Hardware PL-8041-B

REFERENCE SYMBOL	MOTOROLA PART NO.	DESCRIPTION
	3-83677N01	SCREW, captive; M6 x 1.0 x 2.0; 2 used
	42-10128A10	RETAINER, ring; 2 used
	43-84510G01	SPACER; 2 used
	4-10058B37	WASHER, nylon; 6 used
	3-10943J41	SCREW, tapping; TT8 x 1.25 x 16; 4 used
	3-83498N08	SCREW, tapping; M6 x 1.0 x 10; 10 used
	3-83498N10	SCREW, tapping; M3.5 x 0.8 x 8; 6 used
	7-82831N03	FRAME, cabinet
	7-82831N04	FRAME, cabinet
	7-82881N01	BRACKET, pivot; right
	7-82881N02	BRACKET, pivot; left
	15-82821N01	HOUSING, bottom
	42-10217A02	TIE WRAPS (21 used)
	42-82143C09	CABLE CLAMPS, clear (7 used)
	42-82143C02	CABLE CLAMPS, 1/4" (2 used)
	3-134186	SCREW, tapping (2 used)
	3-135500	SCREW, tapping 4-40 x 1/4 (4 used)

TRN5425A 24" Cabinet Shell PL-8042-A

REFERENCE SYMBOL	MOTOROLA PART NO.	DESCRIPTION
	3-10943J41	SCREW, tapping; TT8 x 1.25 x 16; 4 used
	3-10943J45	SCREW, tapping; TT8 x 1.25 x 40 (2 used)
	15-82821N02	HOUSING, top
	15-82832N02	COVER, wraparound
	75-82154D17	PAD, foam; 2 used

TRN5424A Cabinet 29" Hardware PL-8070-B

REFERENCE SYMBOL	MOTOROLA PART NO.	DESCRIPTION
	3-10943J41	SCREW, tapping; TT8 x 1.25 x 16; 4 used
	3-83498N08	SCREW, tapping; M6 x 1.0 x 10; 10 used
	3-83498N10	SCREW, tapping; M3.5 x 0.8 x 6; 6 used
	7-82831N05	FRAME, cabinet
	7-82831N06	FRAME, cabinet
	7-82881N01	BRACKET, right
	7-82881N02	BRACKET, left
	15-82821N01	HOUSING, plastic
	42-10217A02	TIE WRAPS (21 used)
	42-82143C09	CABLE CLAMPS, clear (7 used)
	42-82143C02	CABLE CLAMPS, 1/4" (2 used)
	3-134186	SCREW, tapping (2 used)
	3-135500	SCREW, tapping 4-40 x 1/4 (6 used)
	4-10058B37	WASHER, nylon; 6 used

TRN5426A Cabinet 29" Shell PL-8071-A

REFERENCE SYMBOL	MOTOROLA PART NO.	DESCRIPTION
	3-10943J41	SCREW, tapping; TT8 x 1.25 x 16; 4 used
	3-10943J45	SCREW, tapping; TT8 x 1.25 x 40; 2 used
	15-82821N02	HOUSING, plastic top
	15-82832N03	COVER, cabinet
	75-82154D17	PAD, foam; 2 used

TRN5569A Cabinet 32" Shell PL-8224-O

REFERENCE SYMBOL	MOTOROLA PART NO.	DESCRIPTION
	3-10943J41	SCREW, tapping TT8 x 1.25 x 16; 4 used
	3-10943J45	SCREW, tapping; TT8 x 1.25 x 40; 2 used
	15-82821N02	HOUSING, tap
	15-82832N04	COVER, cabinet
	75-82154D17	PAD; 2 used

TRN5567A Cabinet 32" Hardware PL-8222-A

REFERENCE SYMBOL	MOTOROLA PART NO.	DESCRIPTION
	3-134186	SCREW, tapping; 6-32 x 5/16"; 2 used
	3-10943J41	SCREW, tapping; TT8 x 1.25 x 16"; 4 used
	3-83498N08	SCREW, tapping; star; 12 used
	3-83498N10	SCREW, tapping; star; 6 used
	7-82831N07	FRAME, cabinet
	7-82831N08	FRAME, cabinet
	7-82881N01	BRACKET, pivot; right
	7-82881N02	BRACKET, pivot; left
	15-82821N01	HOUSING, bottom
	42-10217A02	STRAP, tie: 0.91 x 3.62 nylon WHT; 26 used
	42-82143C09	CLAMP, cable; 7 used
	3-135500	SCREW, tapping; 4-40 x 1/4"; 4 used
	42-82143C05	CLAMP, cable; 2 used
	4-10058B37	WASHER, nylon; 6 used

TRN5570A Cabinet 37" Shell PL-2828-O

REFERENCE SYMBOL	MOTOROLA PART NO.	DESCRIPTION
	3-10943J41	SCREW, tapping; TT8 x 1.25 x 16; 4 used
	3-10943J45	SCREW, tapping; TT8 x 1.25 x 40; 2 used
	15-82821N02	HOUSING, top
	15-82832N05	COVER, cabinet
	75-82154D17	PAD: 2 used

TRN5568A Cabinet 37" Hardware PL-2827-A

REFERENCE SYMBOL	MOTOROLA PART NO.	DESCRIPTION
	3-134186	SCREW, tapping; 6-32 x 5/16"; 2 used
	3-135500	SCREW, tapping; 4-40 x 1/4"; 4 used
	3-10943J41	SCREW, tapping; TT8 x 1.25 x 16; 4 used
	3-83498N08	SCREW, tapping; star; 12 used
	3-83498N10	SCREW, tapping; star; 6 used
	7-82831N09	FRAME, cabinet
	7-82831N10	FRAME, cabinet
	7-82881N01	BRACKET, pivot; right
	7-82881N02	BRACKET, pivot; left
	15-82821N01	HOUSING, bottom
	42-10217A02	STRAP, tie: .091 x 3.62 nylon; 26 used
	42-82143C05	CLAMP; cable; 2 used
	42-82143C09	CLAMP, cable; 7 used
	4-10058B37	WASHER, nylon; 6 used

TRN5350A Junction Box, Simplex
TRN5351A Junction Box, Duplex PL-8035-A

REFERENCE SYMBOL	MOTOROLA PART NO.	DESCRIPTION
J611	15-82889N01	connector, receptacle:
J612	1-80758D49	HOUSING, 3-contact, power cord
	9-83238C01	ac outlet w/lug assembly includes:
	29-85911B	OUTLET, ac; 3-prong
		LUG, fasten
P610	15-83183N01	connector, plug:
		HOUSING, 3-contact

mechanical parts

	2-10971A18	NUT, machine: M3 x 0.5; 2 used
	2-10971A18	NUT, machine: M5 x 0.8; 2 used
	3-83497N02	SCREW, machine: M5 x 0.8 x 12
	3-83497N04	SCREW, machine: M3 x 0.5 x 8; 2 used
	3-10943M10	SCREW, tapping; M3 x 0.5 x 8; 2 used
	3-83498N10	SCREW, tapping; M3.5 x 0.6 x 8; 2 used
	4-7683	LOCKWASHER, #4 internal; 2 used
	9-82845L01	CONNECTOR, crimp; 2 used
	9-83358N01	CONNECTOR, wire splice
	15-82835N01	COVER, junction box
	15-82881N01	HOUSING, fuse with mounting hardware
	29-10228A08	TERMINAL, connector
	37-106352	GROMMET
	39-83145N01	CONTACT, plug: (part for P610); 2 used
	39-83145N02	CONTACT, plug (part for P610)
	39-83384N01	CONTACT, plug: (part for J11); 3 used
	42-10217A02	CLIP, cable; 3 used
	42-82143C01	CLIP, cable; 3/16"
	15-82834N01	HOUSING, interconnect (TRN5350A)
	15-83834N03	HOUSING, interconnect (TRN5351A)

TRN5434A Hardware Optional Control Chassis, R2 Receiver
TRN5435A Hardware Optional Control Chassis, Duplex PL-8051-O

REFERENCE SYMBOL	MOTOROLA PART NO.	DESCRIPTION
	3-134185	SCREW, tapping; 6-32 x 1/4"; 4 used
	3-134186	SCREW, tapping; 6-32 x 5/16"
	3-135506	SCREW, tapping; 6-32 x 1/4"; 23 used
	27-82850N01	CHASSIS, rf
	27-82876N01	CHASSIS, card cage
	39-82857N01	CONTACT, ground; 6 used
	42-82888N01	CLIP, detent; 2 used
	46-82856N01	GUIDE, circuit board card; 6 used
	46-82877N01	GUIDE, skt. bd. mtg: (3 used; TRN5434A) (2 used; TRN5435A)
	54-83570K01	LABEL

TRN5428A Power Control Board Cover PL-8044-O

REFERENCE SYMBOL	MOTOROLA PART NO.	DESCRIPTION
	3-488006	SCREW, machine: 6-32 x 1/2"; 5 used
	4-658060	WASHER, insulator; 7/32 x 0.125 x .062; 5 used
	15-82401N01	COVER, control

MSR 2000 Base Station
Miscellaneous Parts Lists
Motorola No. PEPS-34953-C
(Sheet 1 of 2)
1/14/83- V & G

STATION MAINTENANCE

parts list

TRN5431A Cover Repeater PL-8088-O

REFERENCE SYMBOL	MOTOROLA PART NO.	DESCRIPTION
	2-82360B35	NUT, speed
	3-125178	SCREW, machine: 8-32 x 3/4"
	3-83498N02	SCREW, tapping: M3 x 0.5 x 5
	4-647583	WASHER, fiber
	14-82835N01	INSULATOR, terminal block
	15-82858N01	COVER, mode F0
	15-83031N01	COVER, aux, chassis
	42-10128A10	RETAINER, ring rubber

TRN5433A Hardware Optional Control Chassis (1-Receiver) PL-8089-O

REFERENCE SYMBOL	MOTOROLA PART NO.	DESCRIPTION
	3-134185	SCREW, tapping: 8-32 x 1/4"; 4 used
	3-134186	SCREW, tapping: 6-32 x 5/16"
	3-135506	SCREW, tapping: 6-32 x 1/4"; 23 used
	27-82850N01	CHASSIS, rf
	27-82876N01	CHASSIS, card cage
	39-82857N01	CONTACT, ground; 4 used
	42-82888N01	CLIP, detent; 2 used
	46-82858N01	GUIDE, circuit board card; 4 used
	46-82877N01	GUIDE, circuit board mounting; 2 used
	54-83570K01	LABEL

TKN8326A Cable Kit PL-8228-O

REFERENCE SYMBOL	MOTOROLA PART NO.	DESCRIPTION
	1-80763D70	CABLE, coaxial assembly includes:
	28-82331G01	PLUG, single contact (1 used)
	28-82875N01	PLUG, phono; board mount (1 used)
	30-83794C01	COAX CABLE; 45" long
	1-80757D15	CABLE, coaxial assembly includes:
	28-82331G01	PLUG, single contact (1 used)
	30-83794C01	COAX CABLE; 3 1/2" long
	42-10217A02	STRAP, tie (6 used)

TRN5575A Power Supply Cover PL-8206-O

REFERENCE SYMBOL	MOTOROLA PART NO.	DESCRIPTION
	3-83498N08	SCREW, tapping; star; 5 used
	26-84448N01	SHIELD, top
	26-84384N01	SHIELD

TRN5427A Power Cord 110 V PL-8043-O

REFERENCE SYMBOL	MOTOROLA PART NO.	DESCRIPTION
	30-82833N01	LINE CORD; with plug and receptacle

TRN5443A Duplex RF Cover PL-8039-O

REFERENCE SYMBOL	MOTOROLA PART NO.	DESCRIPTION
	1-80756D68	Assembly Front cover eyeleted
	3-136832	SCREW, tapping: 4 x 40 x 3/8"; 15 used
	3-138430	SCREW, tapping: 4-24 x 3/8"; 4 used
	15-82852N01	COVER, top
	42-83123F01	RETAINER; 4 used

TRN5429A Cover, Basic
TRN5430A Cover, Simplex PL-8040-A

REFERENCE SYMBOL	MOTOROLA PART NO.	DESCRIPTION
	1-80758D88	ASSEMBLY COVER; includes:
	5-83124F01	EYELET; 2 used
	15-82851N01	COVER
	2-82360B35	NUT, speed
	3-125178	SCREW, machine: 8-32 x 3/4"
	3-138430	SCREW, tapping: 4-24 x 3/8"; 2 used
	3-83498N02	SCREW, tapping: M3 x 0.5 x 5
	4-647583	WASHER, fiber
	14-82835N01	INSULATOR, terminal block
	15-82858N01	COVER, mode F0 (TRN5430A)
	15-82858N02	COVER, mode basic (TRN5429A)
	15-83031N01	COVER, aux chassis
	42-10128A10	RETAINER, ring rubber
	42-83123F01	RETAINER; 2 used
	42-82879N01	CLIP; 3 used

TRN5442A Labels PL-8242-O

REFERENCE SYMBOL	MOTOROLA PART NO.	DESCRIPTION
F601	85-138179	fuse: 10 amp; 250 V
		mechanical parts
	13-813818	DECAL, patent no.
	33-83748N01	NAMEPLATE
	38-82892N01	CAP, fuse housing; GRY
	54-850440	LABEL, FCC
	54-83040C01	LABEL, audio
	54-83918N01	LABEL, interconnect housing outlet
	54-83919N01	LABEL, interconnect housing, fuse
	54-83922N01	LABEL, as pwr interconnect
	54-64126C01	LABEL, replacement parts

MSR 2000 Base Station
Miscellaneous Parts Lists
Motorola No. PEPS-34953-C
(Sheet 2 of 2)
1/14/83- V & G

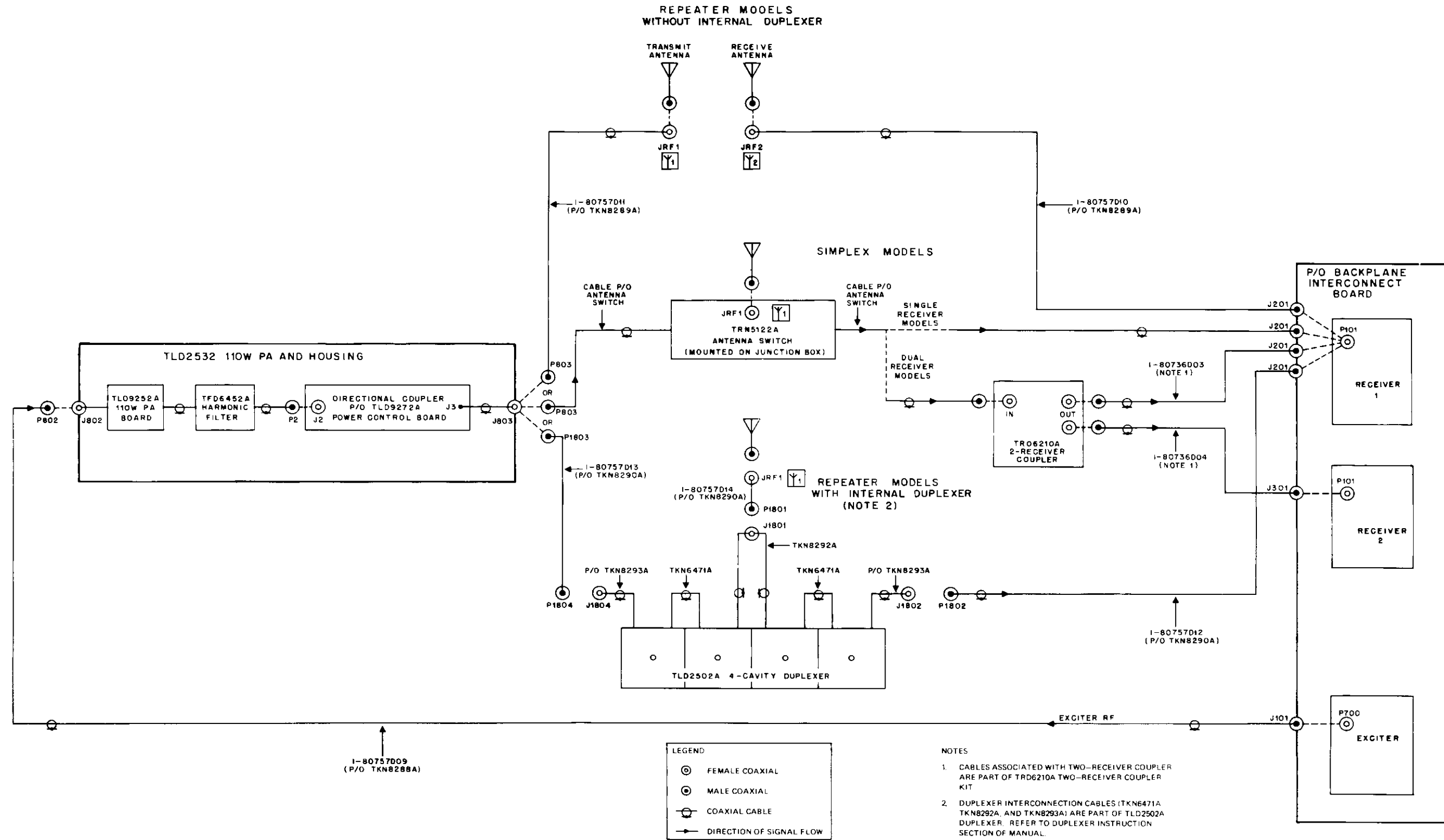

parts list

REFERENCE SYMBOL	MOTOROLA PART NO.	DESCRIPTION
TKN8289A Cable Non-Duplexer PL-8058-A		
JRF1	9-82442E01	connector, receptacle: female; single contact
JRF2	9-82442E01	female; single contact
J201	28-82875N01	male; single contact (phono)
P803	28-84579F01	male; single contact (UHF)
mechanical parts		
2-10971A16		NUT, machine: M3 x 0.5; 8 used
3-83497N04		SCREW, machine: M3 x 0.5 x 8; 8 used
1-80757D10		Assembly cable non-duplexer rcvr includes: JRF2, J201
15-483599		HOOD, receptacle
30-83794C01		CABLE, coaxial (WHT) 47 1/2" used
1-80757D11		Assembly cable, non-duplexer xtrm; includes: JRF1, P803
15-483599		HOOD, receptacle
30-84173E01		CABLE, coaxial (double shield) 19 1/2" used
TKN8288A Cable PA Power and Exciter PL-8054-C		
J101	28-82875N01	connector, plug: male; single contact (phono)
P802	28-84579F04	male; single contact (UHF)
mechanical parts		
1-80757D07		Assembly, cable: PA power red; includes: TERMINAL, ring; 2 used
29-82907N03		TERMINAL, ring; 2 used
1-80757D08		Assembly, cable: PA power black; includes: TERMINAL, ring; 1 used
29-82709N03		TERMINAL, ring; 1 used
29-848903		TERMINAL, lug
1-80757D09		Assembly, cable: exciter; includes: J801, P802
30-83794C01		CABLE, coaxial (WHT) 38 1/2" used
3-134185		SCREW, tapping: 6-32 x 1/4"
42-10217A02		STRAP, tie; (WHT); 3 used
42-82143C08		CLIP, cable
TKN8290A Cable Duplexer PL-8046-A		
JRF-1	9-82442E01	connector: female; single contact
J201	28-82875N01	male; single contact
P1802, 1803, 1804	28-84579F01	connector, plug: male; single contact
mechanical parts		
2-10971A16		NUT, machine: M3 x 0.5; 4 used
3-83497N04		SCREW, machine: M3 x 0.5 x 8; 4 used
42-10217A02		STRAP, tie; 2 used
1-80757D12		ASSEMBLY, cable receiver: includes J201, P1804
1-80757D13		ASSEMBLY, cable transmitter: includes: P1802, 1803
30-83794C01		CABLE, coaxial; 38-1/2" used
1-80757D14		ASSEMBLY, cable: 44" used
30-84173E01		CABLE, coaxial: 44" used
15-483599		HOOD, receptacle
28-84579F01		PLUG, UHF
30-84173E01		CABLE, coaxial; 33" used

MSR 2000 Intermittent Duty Base Station
RF Interconnecting Diagram & Parts List
Motorola No. PEPS-34954-C
9/13/84 - V & G

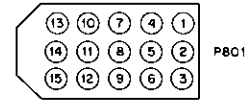
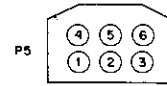
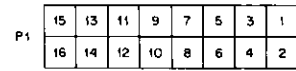
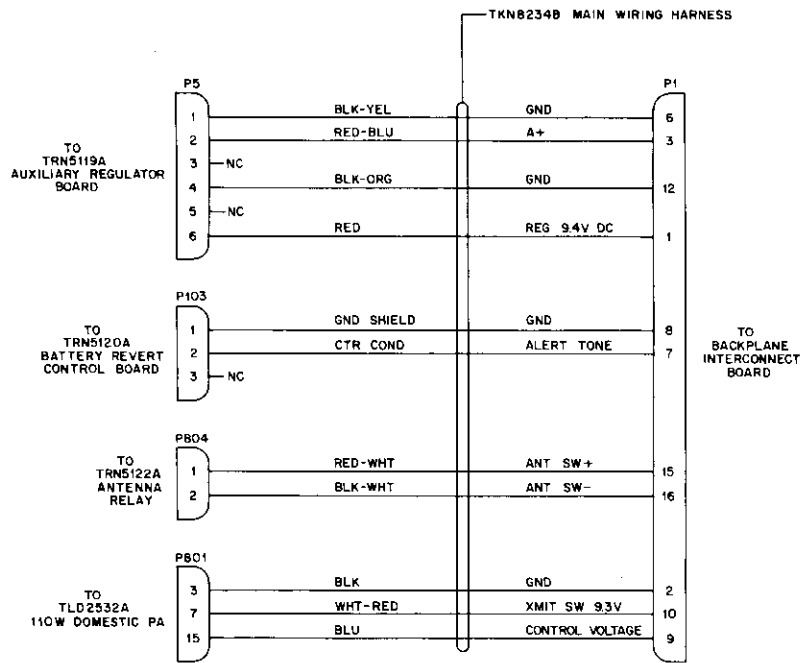

VIEWED FROM CONNECTION END

DEPS-34674-A

parts list

TKN8234B Main Cable

PL-8053-C

REFERENCE SYMBOL	MOTOROLA PART NO.	DESCRIPTION
connector, receptacle:		
P1	15-84248N01	16 position
P5	15-84954L01	6 position
P103	15-83498F39	3 position
P801	15-83292K02	15 position
P804	15-84860K02	2 position
mechanical parts		
	29-84249N01	TERMINAL; 11 used
	29-84706E05	TERMINAL: crimp pin; 4 used
	29-84706E06	TERMINAL: crimp socket; 5 used
	30-824278	CABLE, shielded (ORG) 49 1/4" used
	42-10217A02	STRAP, tie; 18 used
	29-83499F01	TERMINAL; 2 used

*MSR 2000 Intermittent Duty Base Station
TKN8234B Main Wiring Harness
Schematic Diagram and Parts List
Motorola No. PEPS-34955-D
9/13/84-*

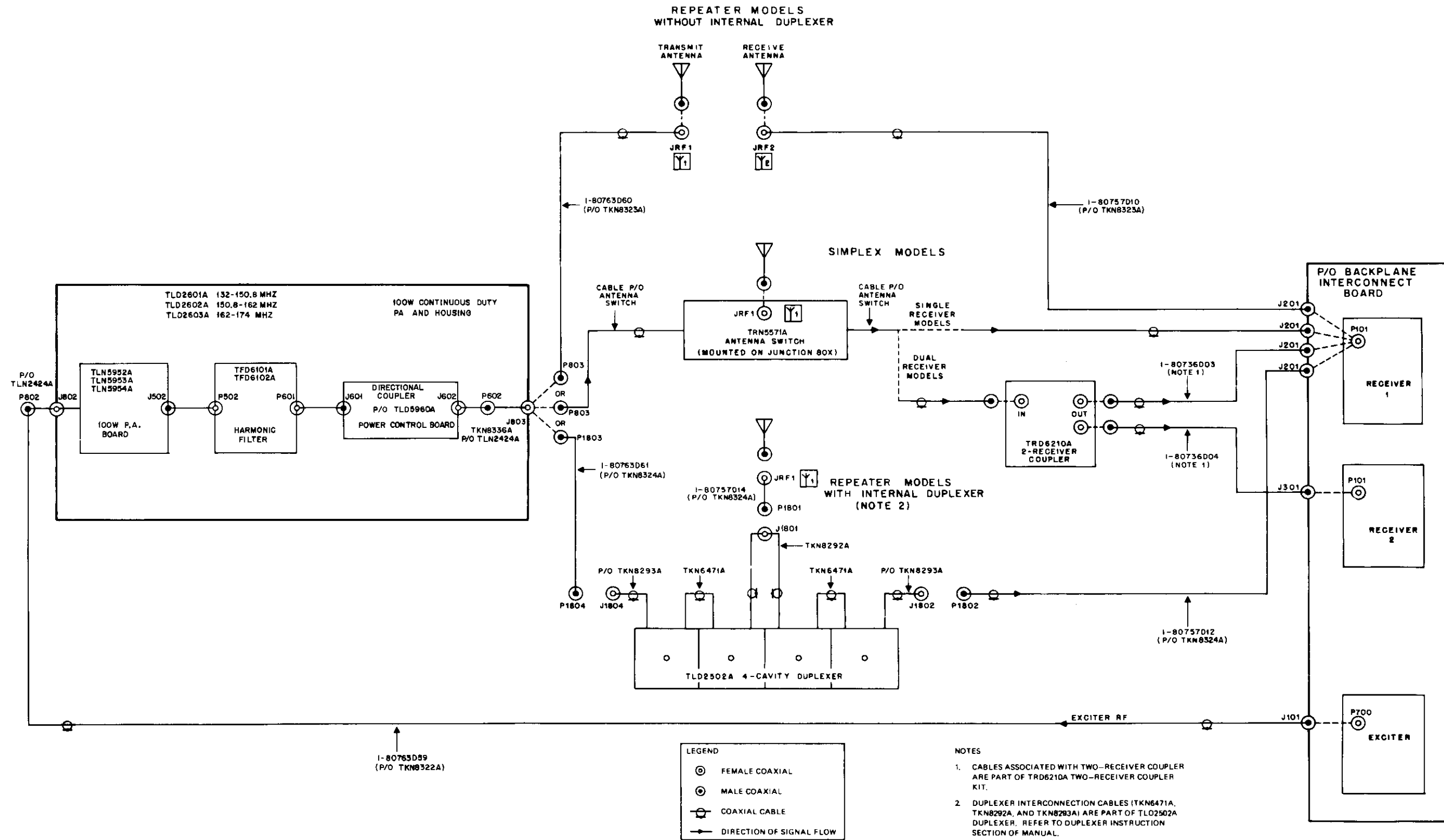

parts list

REFERENCE SYMBOL	MOTOROLA PART NO.	DESCRIPTION
JRF1, 2	9-82442E01	connector, receptacle: female; single-contact (UHF)
J201	29-82875N01	male; single-contact (phono)
P803	28-84987D01	male; single-contact (BNC)
mechanical parts		
1-80757D10		ASSEMBLY CABLE, non-duplexer, RCVR; includes: JRF2, J201
5-82050H04		EYELET
15-483599		HOOD, receptacle
30-83794C01		CABLE, coaxial (WHT) 46" used
1-80763D65		ASSEMBLY CABLE, non-duplexer EIA rack includes: 15-483599
30-84173E01		CABLE, coaxial shielded; 36" used (TKN8329A)
1-80763D60		ASSEMBLY CABLE, non-duplexer XMTR includes: JRF1, P803
15-483599		HOOD, receptacle
30-84173E01		CABLE, coaxial shielded 28" used (TKN8323A)
TKN8328A Cable PA Power and Exciter EIA Rack		
PL-8223-A		
REFERENCE SYMBOL	MOTOROLA PART NO.	DESCRIPTION
J101	28-82875N01	connector, plug: male; single-contact (phono)
P802	28-83099K01	male; single-contact (BNC)
mechanical parts		
1-80763D57		ASSEMBLY CABLE, PA power, RED; includes: 29-82907N03
1-80763D58		ASSEMBLY CABLE, PA power, BLK; includes: 29-848903
29-848903		LUG, crimp terminal
29-82907N03		TERMINAL, ring
1-80763D59		ASSEMBLY CABLE, exciter; includes: J801, P802
5-82050H04		EYELET
30-83794C01		CABLE, coaxial (WHT) 51" used (TKN8322A)
1-80763D64		ASSEMBLY CABLE, exciter; (EIA) includes: J801, P802
5-82050H04		EYELET
30-83794C01		CABLE, coaxial (WHT) 64" used (TKN8328A)
TKN8324A Cable Duplexer		
PL-8220-O		
REFERENCE SYMBOL	MOTOROLA PART NO.	DESCRIPTION
JRF1	9-82442E01	connector, receptacle: female; single-contact
J201	28-82875N01	male; single-contact (phono)
P1801, 1802	28-84579F01	connector, plug: male; single-contact
P1803	28-84987D01	male; single-contact
P1804	28-84579F01	male; single-contact
mechanical parts		
1-80757012		ASSEMBLY CABLE DUPLEXER (RCVR) includes: J201, P1804
5-82050H04		eyelet
30-83794C01		CABLE, coaxial (WHT) 30" used
1-80754D14		ASSEMBLY CABLE ANTENNA DUPLEXER; includes: JRF1, P1801
15-483599		HOOD, receptacle
30-84173E01		CABLE, coaxial double shielded; 30-1/2" used
1-80763D61		ASSEMBLY CABLE DUPLEXER (XMTR) includes: P1802, 1803
30-8173E01		CABLE, coaxial; 50" used
2-10971A16		NUT, machine; M3 x 0.5; 4 used
3-83487N04		SCREW, machine; M3 x 0.5 x 8; 4 used
42-10217A02		STRAP, tie .091 x 3.62 nylon; 2 used

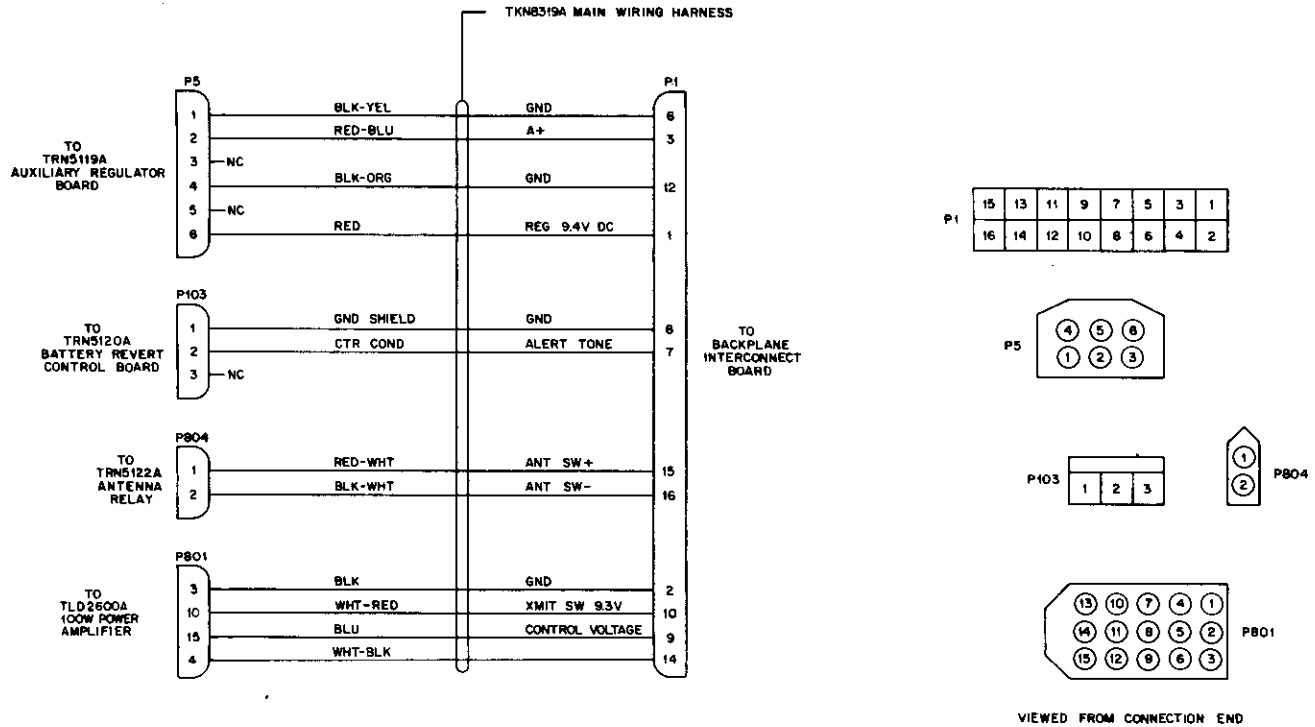

OEPS-35287-0

parts list

TKN8319A Main Cable

PL-8225-0

REFERENCE SYMBOL	MOTOROLA PART NO.	DESCRIPTION
P1	15-84248N01	connector, receptacle: 16 position
P5	15-84954L01	6 position
P103	15-83498F39	3 position
P801	15-83292K02	15 position
P804	15-84880K02	2 position
mechanical parts		
	29-84249N01	TERMINAL; 12 used
	29-83499F01	TERMINAL; 2 used
	29-84706E05	TERMINAL: crimp pin; 4 used
	29-84706E06	TERMINAL: crimp socket; 6 used
	30-824278	CABLE, shielded (ORG) 52" used
	42-10217A02	STRAP, tie; 47 used

MSR 2000 Continuous Duty Base Station
TKN8319A Main Wiring Harness
Schematic Diagram and Parts List
Motorola No. PEPS-35372-0

11/15/82 - V & G

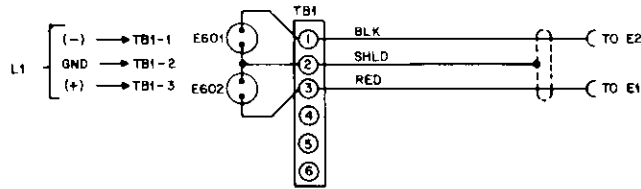

TKN8286A TWO-WIRE LINE CABLE KIT

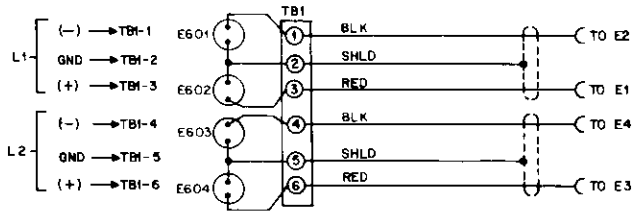

TKN8287A FOUR-WIRE LINE CABLE KIT

•8EPS-34736-0

parts list

TKN8320A and TKN8321A Two-Wire and Four-Wire EIA Cable Kit
TKN8286A and TKN8287A Two-Wire and Four-Wire Line Cable Kit PL-8052-A

REFERENCE SYMBOL	MOTOROLA PART NO.	DESCRIPTION
E601 thru 604	80-83029H01	spark, gap: 240 V
mechanical parts		
	29-812979	LUG, crimp terminal: TKN8286A, TKN8320A; 2 used; TKN8287A, TKN8321A; 4 used
	30-844810	CABLE, 2-conductor shielded; 31-1/2" used (TKN8287A, TKN8286A)
	30-844810	CABLE, 2-conductor shielded; 34" used (TKN8287A)
	30-844810	CABLE, 2-conductor shielded; 38" used (TKN8321A, TKN8320A)
	30-844810	CABLE, 2-conductor shielded; 40-1/2" used (TKN8321A)
	31-82893N01	TERMINAL, block with mounting rings
	42-10217A02	STRAP, tie; TKN8286A, TKN8320A; 2 used; TKN8287A, TKN8321A; 2 used

STATION MAINTENANCE

*TKN8320A and TKN8321A Two-Wire and Four-Wire EIA Cable Kit
TKN8286A and TKN8287A Two-Wire and Four-Wire Line Cable Kit
Schematic Diagram and Parts List
Motorola No. PEPS-34956-A*

11/15/82 - V & G



MOTOROLA INC.

Communications
Sector

RECEIVER
MODEL SERIES TRD6170A, TRD6180A, AND TRD6190A



Receiver Model Table

Model	Frequency (MHz)	Description	Application
TRD6171A	132-150.8	Multi-Frequency 10.7 MHz I-F, Non-Filtered	Used with Single Receiver Stations
TRD6172A	146-174		
TRD6181A	132-150.8	Multi-Frequency 10.7 MHz I-F, Filtered	Used with 2-Receiver Stations and Repeater Stations
TRD6182A	146-174		
TRD6191A	132-150.8	Multi-Frequency 10.8 MHz I-F, Filtered	Used with 2 Receiver Stations Where Shifted I-F is Required.
TRD6192A	146-174		

SPECIFICATIONS

Input Impedance	50 ohms		
Number of Channels	1, 2, 3, or 4		
Frequency Separation	2.0 MHz		
I-F Frequency	10.7 MHz or 10.8 MHz		
EIA Modulation Acceptance	± 7 kHz Minimum		
Frequency Stability	± .0005% from -30 °C to +60 °C ambient (+25 °C reference) ± .0002% Optional*		
Channel Spacing	20 kHz, 25/30 kHz		
Sensitivity:		With Preamp**	Without Preamp
20 dB Quieting	Less Than	.25 uV	.50 uV
EIA SINAD	Less Than	.20 uV	.35 uV
Selectivity:			
EIA SINAD	20 kHz Channel 25/30 kHz Channel	85 dB 95 dB	90 dB 100 dB
Intermodulation:			
EIA SINAD	20 kHz Channel 25/30 kHz Channel	75 dB (Minimum) 80 dB (Minimum)	80 dB (Minimum) 85 dB (Minimum)
Spurious and Image Rejection		100 dB (Minimum)	100 dB (Minimum)

* Available with option C621, C622, C623, C624.

** Optional Model HLD4050A RF Preamp.

1. DESCRIPTION

1.1 These receivers are fully transistorized units that receive FM signals on one to four crystal-controlled frequencies. In a multi-frequency receiver, only one frequency can be received at a time.

1.2 Each receiver includes an rf preselector, mixer, local oscillator injection circuitry, high gain selective i-f stages, quadrature detector, audio preamplifier, and a low-ripple 9.5 volt regulator. The receiver develops a low noise audio signal from a frequency

modulated "on-channel" rf carrier in the 132-174 MHz range. An optional rf preamplifier may be used with any of these receivers.

1.3 All circuits are constructed on a single plug-in circuit board which is easily accessible for servicing. The receiver plugs into the backplane interconnect board which provides all dc, audio, and rf connections thereby eliminating all interconnecting wiring. All alignment points are accessible through the top of the rf compartment cover.

RECEIVER

technical writing services

2. THEORY OF OPERATION

2.1 PI FILTER, RF PRESELECTOR, OPTIONAL PREAMPLIFIER

The receive port of the antenna switch is connected to the 5 cavity helical resonator rf preselector through the input "pi" filter. The "pi" filter, consisting of C135, C136, and L112, provides additional filtering for higher frequency spurious responses. The steep skirted rf preselector filter has a bandwidth of 2.0 MHz and ultimate rejection of 100 dB. To provide additional front-end selectivity while minimizing loss, the optional rf preamplifier is inserted in the housing between the second and third cavities. The output of the preselector (L5) is connected to the gate of N-channel JFET mixer, Q103.

2.2 LOCAL OSCILLATOR INJECTION CIRCUITRY

Plug in crystal oscillator modules (channel elements) provide a stable, temperature compensated frequency which is applied to injection amplifier Q101. Each receiver is capable of receiving up to four distinct frequencies. The output of Q101 (typical gain of 15 dB) passes through a two pole bandpass filter which attenuates unwanted harmonics of the injection frequency. The injection level of +12 dBm (typical) is coupled to the source of mixer Q103.

2.3 MIXER

Excellent intermodulation immunity is provided by a JFET mixer, Q103. The filtered receive input and injection signal are applied to the gate and source respectively. The output at the drain is applied to impedance matching circuitry which emphasizes the difference frequency applied to the i-f circuitry. Both the mixer and the following impedance matching circuitry are shielded.

2.4 I-F CIRCUITRY

2.4.1 Several stages of filtering and amplification are employed in the i-f circuitry. Selective i-f filtering is accomplished using dual-resonator, mode coupled monolithic crystals cut to a fundamental frequency of 10.7 MHz or 10.8 MHz. Due to the inherent piezoelectric properties of the crystal material, input signals selectively produce mechanical vibrations which propagate through the device. At the output the same piezoelectric property selectively converts the mechanical vibrations into the i-f electrical signal.

2.4.2 Refer to Figure 1. The high "Q" of the crystals create steep skirts which result in excellent on-channel intelligibility and off-channel signal rejection. The i-f circuitry requires no tuning and makes extensive use of shielding.

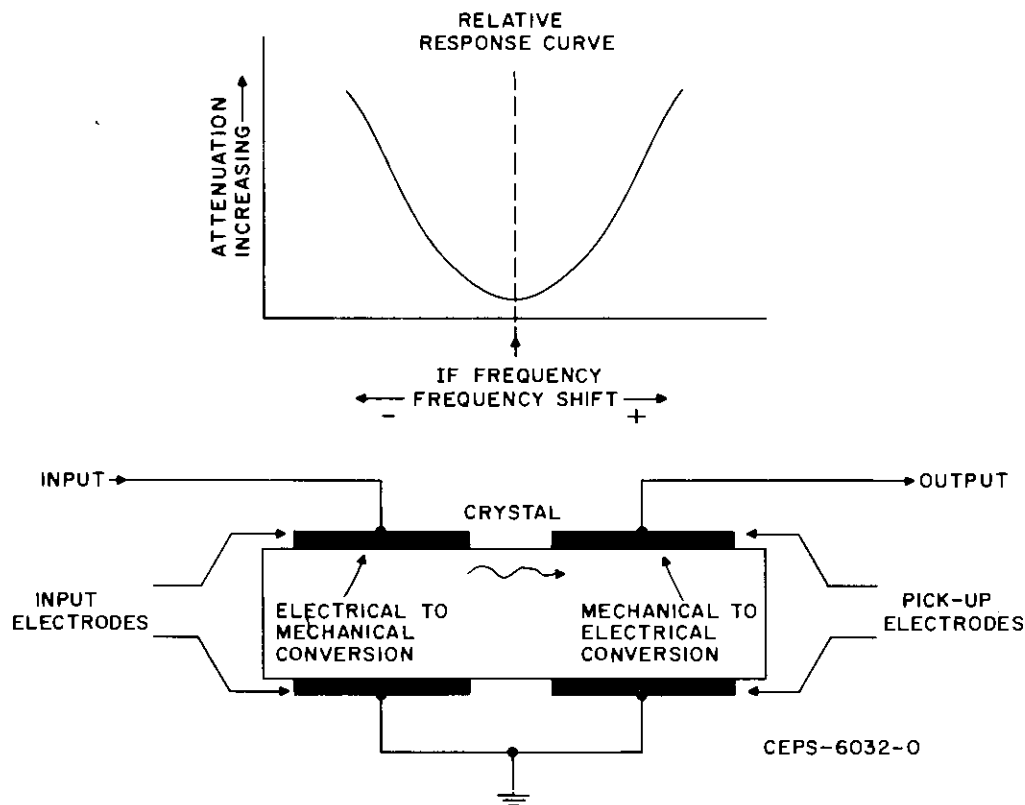

Figure 1. Simplified Piezoelectric Coupling Diagram

2.4.3 The first crystal filter is a single 2-pole device, Y201. This stage is followed by a matching network, 16 dB discrete amplifier Q201, additional matching, and 4-pole filter Y202-Y203. The output of the first 4-pole filter is applied to a matching network and then to high gain (approximately 50 dB) 2nd i-f amplifier U201. The output of U201 is applied to matching circuitry, a 2nd 4-pole filter Y204-Y205, final matching circuitry, and limiter/detector U202.

2.5 LIMITER/DETECTOR

Limiter/Detector U202 is a 16-pin monolithic integrated circuit that internally includes three stages of i-f amplification for limiting, a quadrature fm detector, audio preamplifier, and alignment metering output. The recovered audio output of approximately 80 mV is applied to discrete audio preamplifier Q202-Q203, which provides the 250 mV receiver detected audio level required by the R1 (or R2) audio board in the control package. Adjustment of the quadrature detector is provided by L201.

2.6 9.5 VOLT REGULATOR

The regulated 9.5 volts and 13.8 volts provided to the receiver from the station power supply are applied to Q104 and Q105, resulting in a highly regulated and filtered 9.5 volts. This highly regulated 9.5 volts is supplied to the receiver channel elements, quadrature detector U202, and audio preamplifier Q202 to assure good receiver hum and noise performance.

2.7 DELAYED KEYED A +

This circuit (Q102) provides for disabling of the receiver channel element while the base station is in the transmit mode and prevents audio feed back to the receiver.

3. MAINTENANCE

Malfunctions in the receiver can be localized by using the optional built-in station metering kit or connecting a Motorola portable test set to the receiver metering receptacle and making stage measurements. The meter readings may be compared to the values shown on the receiver functional diagram, but preferably, a log of readings should be maintained for reference. Each new set of readings should then be compared to previous readings. An abrupt change in a meter reading indicates a circuit failure while a gradual change in a reading may indicate an impending failure which can be corrected before operation becomes marginal. Refer to the Receiver Maintenance section for further information.

4. RECEIVER FUNCTIONAL TESTS

4.1 AUDIO AND SQUELCH TEST

The receiver and R1 audio board should provide 1.0 watts of audio when the VOLUME control on the

R1 audio board is set fully clockwise and a strong carrier signal is received that is modulated ± 3.0 kHz deviation with a 1000 Hz tone. When the rf input signal is reduced to minimum and the SQUELCH control on the R1 audio board is set at threshold, the speaker should be quieted. Increasing the rf input signal a small amount should again produce noise in the speaker. On *Private-Line* models, no signal should be heard from the speaker unless the signal has the proper PL tone modulation. These circuits may be checked as follows:

Step 1. PL disable station. Connect speaker to test connector on mother board. Adjust the signal generator for 1000 μ V input to the receiver modulated with 1000 Hz tone for ± 3.0 kHz deviation.

Step 2. Connect an ac voltmeter to measure the voltage between pins 1 and 2 of the control metering socket.

Step 3. Set the VOLUME control on the R1 audio board fully clockwise. The ac voltmeter should indicate at least 2.8 volts rms.

Step 4. Decrease the signal generator output to minimum. Remove modulation from signal generator.

Step 5. Set the SQUELCH control at threshold, that is, clockwise until the noise just quiets.

Step 6. Increase the signal generator output slightly until the noise is again heard in the speaker. No more than .125 μ V should be required.

Step 7. On *Private-Line* radios, enable the PL function. No noise should be heard in the speaker.

Step 8. Modulate the rf signal with the proper *Private-Line* tone with ± 500 Hz deviation. Adjust signal generator output until noise is again heard in speaker. (See audio section for PL squelch specifications).

4.2 20 DB QUIETING TEST

With no signal input and the receiver unsquelched, noise should be heard in the speaker or indicated on position 11 of the portable test set (function selector switch in RCVR position). When a carrier frequency signal is injected, the noise should decrease. No more than 0.5 μ V (.25 μ V if radio is equipped with rf preamplifier) should be required to decrease the noise 20 dB. This may be checked as follows:

Step 1. Unsquelch receiver by turning the SQUELCH control on the R1 audio board fully counterclockwise. PL disable the receiver.

Step 2. Set the function selector switch on the portable test set to the RCVR position and the selector switch to position 11.

Step 3. Adjust VOLUME control on the R1 audio board for noise in the speaker and a reading on the test set meter. A reading of 1.5 V ac is a convenient reference value to use.

Step 4. Connect an rf signal generator (set to the receiver carrier frequency) to the antenna input connector.

Step 5. Beginning with minimum signal level, increase the signal generator output until the meter 11 reading drops to 1/10 the reference value in Step 3, that is 0.15 V ac. No more than 0.5 microvolt output from the signal generator should be required to quiet the receiver.

4.3 RECEIVER GAIN MEASUREMENTS

NOTE

Before making any receiver gain measurements, make sure the case of every crystal filter has a good conductive path to ground. A continuity test should indicate less than 1 ohm between the crystal filter case and the receiver circuit board ground plating. A bad ground connection may cause errors in gain measurements.

Step 1. Proper receiver alignment is essential to this procedure portion of the Station Alignment. Perform a complete receiver alignment as given in the "Receiver Alignment" section of this manual.

Step 2. Refer to the Receiver Functional Block Diagram, receiver schematic diagram, and the receiver circuit board detail diagram while performing this procedure.

Step 3. Adjust the rf signal generator output frequency to the receive channel frequency. Adjust the rf signal generator output to provide the required receiver input voltage for a particular test point. Then, using an rf ac voltmeter, measure the rf signal voltage between the test point and a nearby chassis ground point. At every test point, the measured voltage should be within ± 6 dB of the given value.

5. TROUBLESHOOTING TECHNIQUES

5.1 VISUAL INSPECTION

The first step in the troubleshooting procedure should be a thorough visual inspection of the receiver

and, in particular, the receiver board. Corrosion, burned or damaged components are usually easily seen and may be the cause or a symptom of the receiver malfunction. An improperly installed receiver shield can cause a degradation in receiver performance.

After the "obvious" problems have been corrected, repeat the receiver board performance tests. If the tests still produce unsatisfactory results, refer to the receiver troubleshooting chart in this section. The troubleshooting chart provides a systematic procedure for isolation of the defective stage and component.

As much information as possible has been included on the troubleshooting chart. However, it will be necessary to occasionally refer to the receiver schematic diagram and circuit board detail. Detailed procedures regarding alignment as a troubleshooting technique, integrated circuit troubleshooting, receiver gain measurements, and crystal troubleshooting follow in the remaining paragraphs of this section.

5.2 ALIGNMENT AS A TROUBLESHOOTING TECHNIQUE

Low meter readings, and otherwise abnormal performance of the receiver are very often corrected by realignment. Therefore, alignment should be one of the first troubleshooting steps performed for these symptoms.

5.3 TROUBLESHOOTING INTEGRATED CIRCUITS

Integrated circuits (IC) are very reliable components and should not be replaced unless it is definitely indicated that the IC is the defective component. Before replacing an IC, make sure that the external components in the circuit are normal. The IC's on the receiver board may be checked by dc voltage measurements. Refer to schematic diagram for correct voltages.

5.4 TROUBLESHOOTING CRYSTALS

A defective filter crystal can best be found by performing an i-f gain check per the schematic diagram. A defective crystal will show an abnormally high insertion loss. If the crystal is found to be defective because of high insertion loss or an ungrounded case, it should be replaced.

RECEIVER TROUBLESHOOTING CHART

RECEIVER TROUBLESHOOTING CHART

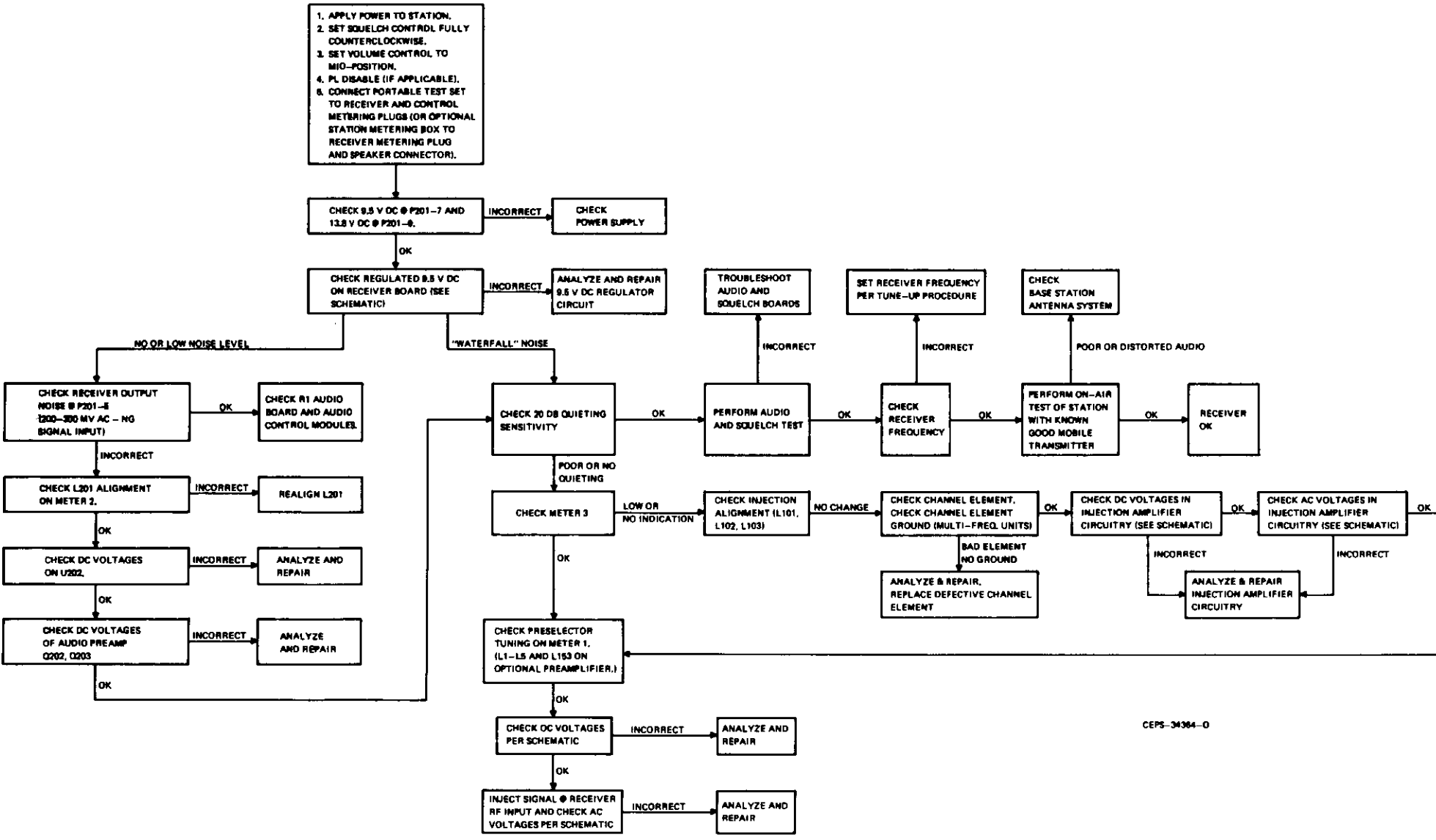

CEPS-34364-0

RECEIVER TROUBLESHOOTING CHART

RECEIVER MAINTENANCE

RECEIVER FUNCTIONAL BLOCK DIAGRAM

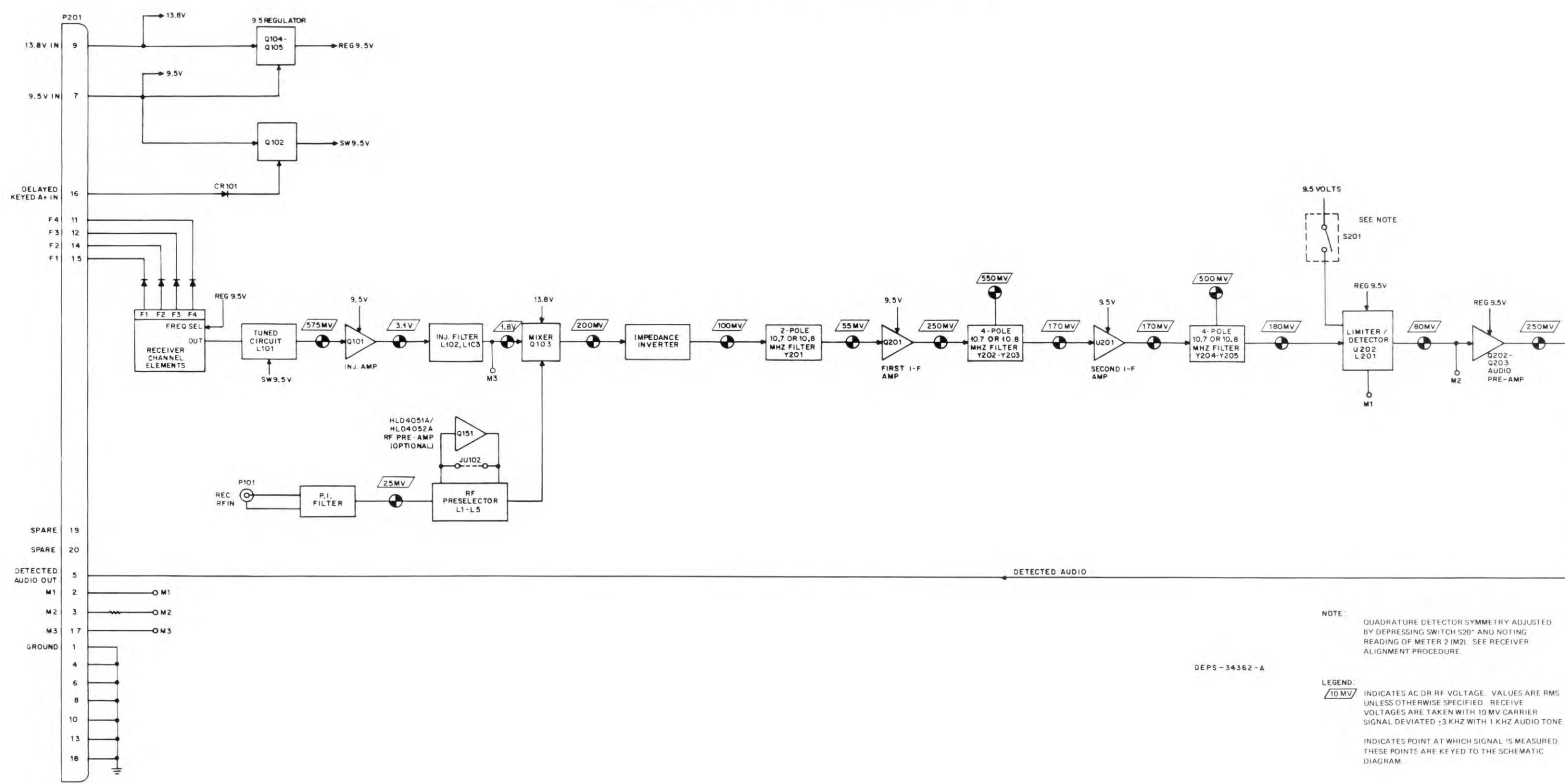

RECEIVER CIRCUIT BOARD DETAIL

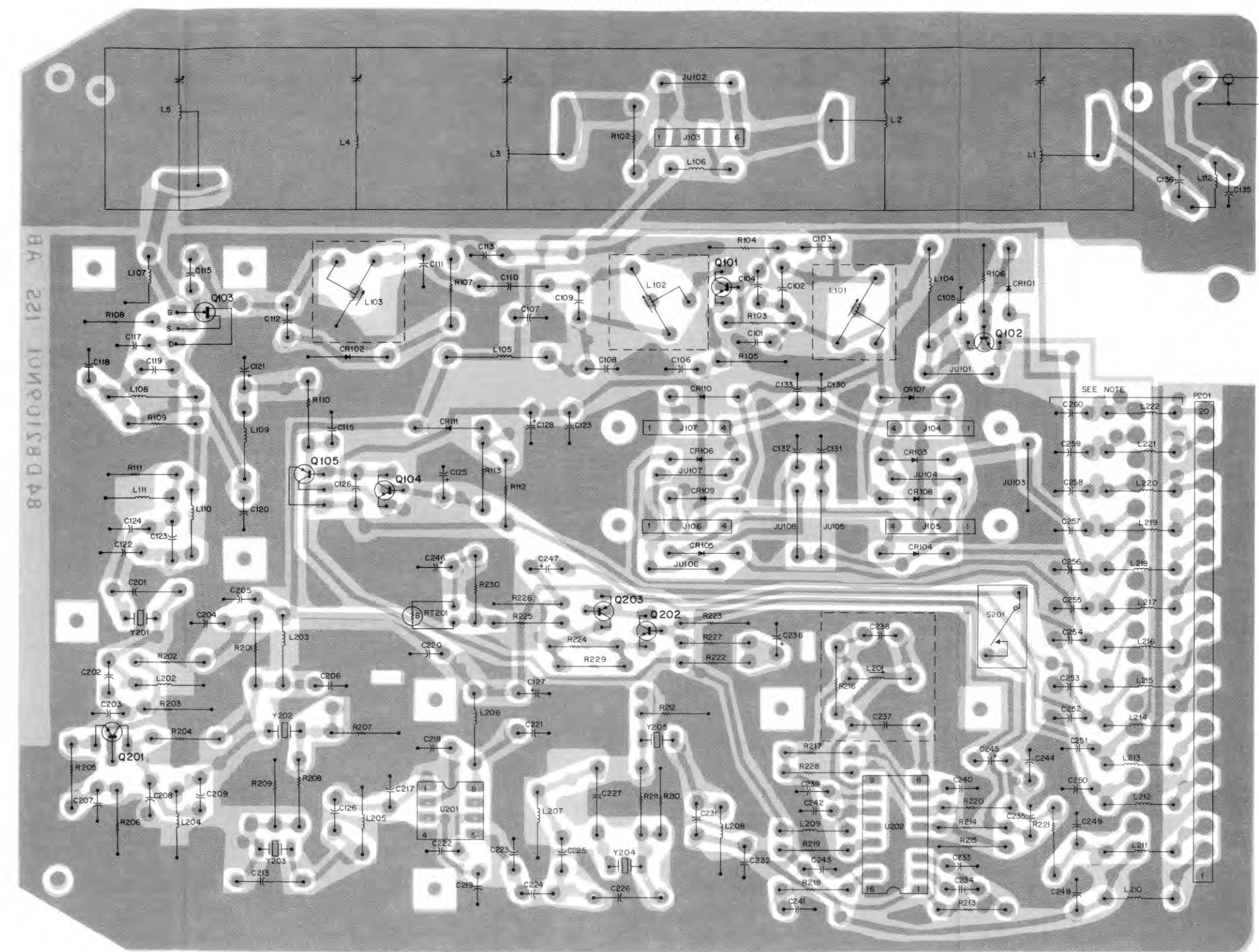

RF PREAMPLIFIER



LEGEND
 L = 136-144 MHz (HLD4051A)
 H = 146-174 MHz (HLD4052A)

NOTE:
 C248 THRU C260 ARE DELETED AND L210 THRU L222 ARE REPLACED WITH JUMPERS FOR MODEL TRD 6172A RECEIVER ONLY.

SOLDER SIDE = BD EEP5-34340-D
 COMPONENT SIDE = BD EEP5-34341-D
 GL 80 EEP5-34342-D

RECEIVER SCHEMATIC DIAGRAM

MODEL	FREQUENCY (MHZ)
TRD6171A	
TRD6181A	132-150.8
TRD6191A	
TRD6172A	
TRD6182A	146-174
TRD6192A	

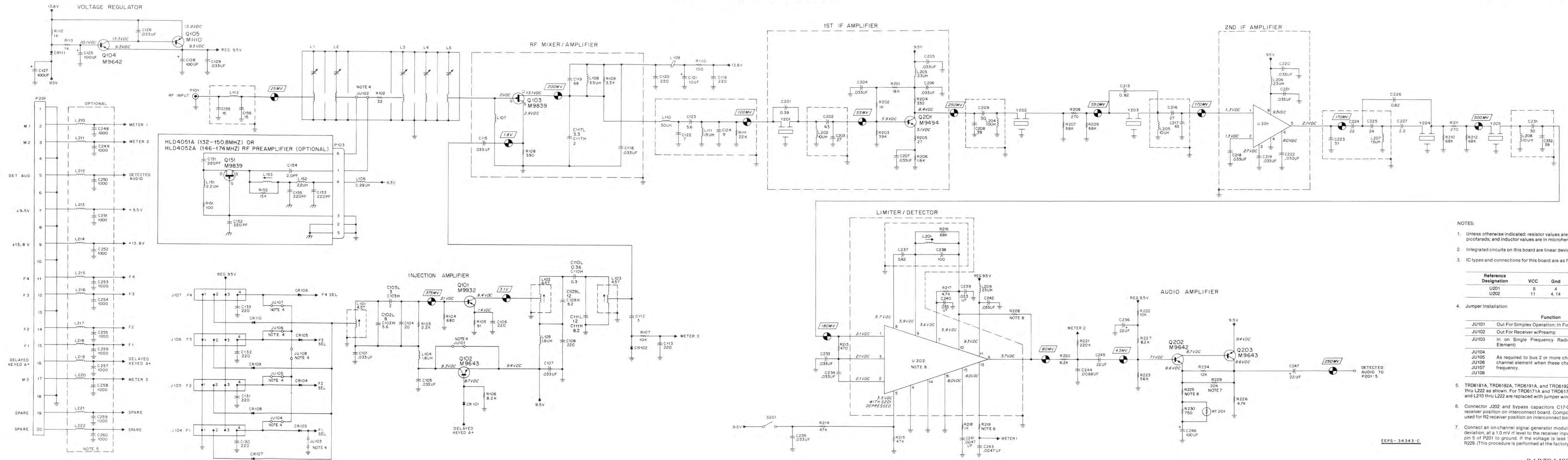
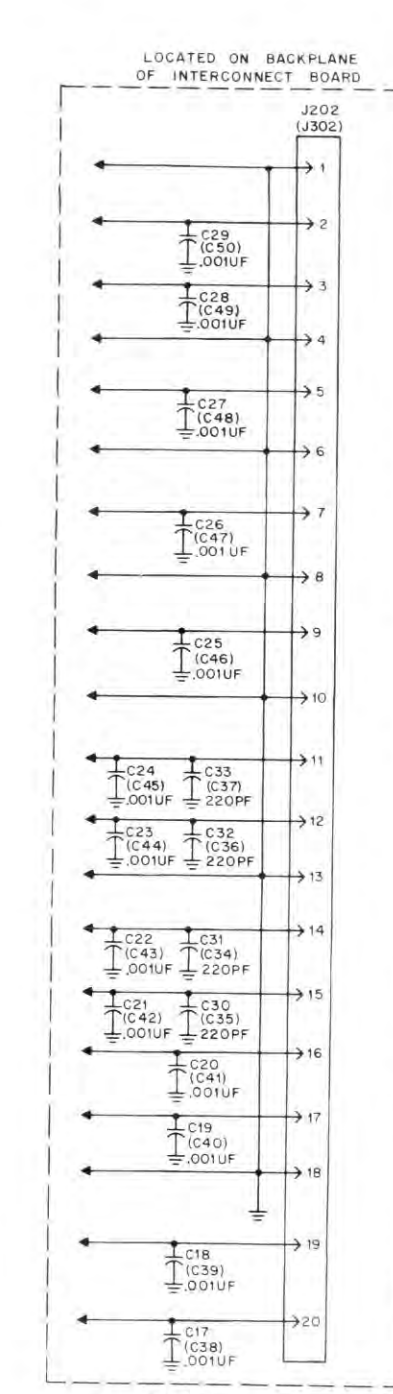

- NOTES:
- Unless otherwise indicated, resistor values are in ohms; capacitor values are in picofarads; and inductor values are in microhenries.
 - Integrated circuits on this board are linear devices.
 - IC types and connections for this board are as follows:

Reference Designation	VCC	Gnd
U201	8	4
U202	11	4, 14

4. Jumper Installation
- | Jumper | Function |
|--------|--|
| JU101 | Out For Simplex Operation; In For RPTX Operation |
| JU102 | Out For Receiver w/Preamp |
| JU103 | In on Single Frequency Radios (To Enable F1 Channel Element) |
| JU104 | As required to bus 2 or more channel select lines to a single channel element when these channels use the same receiver frequency. |
| JU105 | |
| JU106 | |
| JU107 | |
| JU108 | |

- TRD6181A, TRD6182A, TRD6191A, and TRD6192A use C248 thru C260 and L210 thru L222 as shown. For TRD6171A and TRD6172A, C248 thru C260 are deleted and L210 thru L222 are replaced with jumper wires.
- Connector J202 and bypass capacitors C17-C29 and C30-C33 used for R1 receiver position on interconnect board. Component designators shown in () used for R2 receiver position on interconnect board.
- Connect an on-channel signal generator modulated with a 1.0 kHz tone, 3 kHz deviation, at a 1.0 mV r/l level to the receiver input. Measure the ac voltage from pin 5 of P201 to ground. If the voltage is less than 200 mV rms, then cut out R229. (This procedure is performed at the factory prior to shipment.)

EEPS-34343-C

PARTS LISTS SHOWN ON BACK OF THIS DIAGRAM

parts list

TRD6171A, TRD6172A 10.7 MHz I-F, Receiver, Non-Filtered
 TRD6181A, TRD6182A 10.7 MHz I-F, Receiver, Filtered
 TRD6191A, TRD6192A 10.8 MHz I-F, Receiver, Filtered
 PL-7936-C

REFERENCE SYMBOL	MOTOROLA PART NO.	DESCRIPTION
		capacitor, fixed: pF ± 5%; 50 V; unless otherwise stated
C101	21-11021H06	.033 uF + 80-20%
C102L	21-82204B31	8.0 ± 0.25 pF
C102H	21-82204B75	5.6 ± 0.25 pF
C103L	21-11022G12	3 ± 0.25 pF
C103H	21-11022G08	2 ± 0.25 pF
C104	21-11022G37	20
C105	21-11021H06	.033 uF + 80-20%
C106	21-11021E05	220 ± 10%
C107	21-11021H06	.033 uF + 80-20%
C108	21-11021E05	220 ± 10%
C109L	21-11022H29	12
C109H	21-11022H23	8.1 ± 0.5 pF; N150
C110L	21-842041	0.36
C110H	21-82450B26	0.3 ± 10%; 500 V
C111L	21-11022H29	12
C111H	21-11022H23	8.2 ± 0.5 pF; N150
C112	21-11022G12	3 ± 0.25 pF
C113	21-11021E05	220 ± 10%
C115	21-11021H06	.033 uF + 80-20%
C116	21-11021E05	220 ± 10%
C117L	21-11014H13	3.3 ± 0.25 pF
C117H	21-11022G08	2 ± 0.25 pF
C118	21-11021H06	.033 uF + 80-20%
C119	21-11022G50	68
C120	21-11021E05	220 pF ± 10%
C121	23-11019A21	10 uF ± 20%; 35 V
C122	21-82989E17	7 ± 0.25 pF; 500 V
C123	21-83406D64	5.6 ± 0.25 pF
C124	21-82989E21	9 ± 0.25 pF; 500 V
C125	23-11019A46	100 uF ± 20%; 25 V
C126	21-11021H06	.033 uF + 80-20%
C127, 128	23-11019A46	100 uF ± 20%; 25 V
C129	21-11021H06	.033 uF + 80-20%
C130 thru 133	21-11021E05	220 ± 10%
C135, 136	21-11022G34	15
C201	21-82450B07	0.39; 500 V
C202	21-11022G45	43
C203	21-11022G40	27
C204 thru 207	21-11021H06	.033 uF + 80-20%
C208	21-11022G44	39
C209	21-11022G41	30
C213	21-82450B44	0.82; 500 V
C216	21-11022G40	27
C217	21-11022G45	43
C218 thru 222	21-11021H06	.033 uF + 80-20%
C223	21-11014H42	51; 100 V
C224	21-11022G38	22
C225	21-11022G39	24
C226	21-82450B44	0.82; 500 V
C227	21-82450B17	2.2; 500 V
C231	21-11022G41	30
C232	21-11022G44	39
C233 thru 235	21-11021H06	.033 uF + 80-20%
C236	23-11019A27	22 uF ± 20%; 25 V
C237	21-82450B46	0.62 ± 5%; 500 V
C238	21-82358G12	100; 100 V; N080
C239, 240	21-11021H06	.033 uF + 80-20%
C241	21-11021E21	.0047 uF ± 10%
C242	21-11021H06	.033 uF + 80-20%
C243	21-11021E21	.0047 uF ± 10%
C244	21-11017B07	.0068 uF ± 10%
C245	23-11019A27	22 uF ± 20%; 25 V
C246	23-11019A46	100 uF ± 20%; 25 V
C247	23-11019A27	22 uF ± 20%; 25 V
C248 thru 260	21-11021E13	1000 (TRD6182A, 6192A)
		diode: (see note)
CR101	48-83654H01	silicon
CR102	48-82139G01	germanium
CR103 thru 110	48-83654H01	silicon
CR111	48-83654H02	silicon
		connector, plug:
J103	28-80181B01	male; 6-contact
J104 thru 107	28-80096A01	male; 4-contact
		coil, rt:
L1L	24-80032A07	helical; VIO
L1H	24-80032A02	helical; RED
L2L	24-80032A08	helical; BRN
L2H	24-80032A03	helical; ORG
L3L	24-80032A09	helical; GRN
L3H	24-80032A05	helical; NAT
L4L	24-80032A06	helical; BLU
L4H	24-80032A01	helical; NAT
L5L	24-80032A10	helical; BLU
L5H	24-80032A04	helical; YEL

REFERENCE SYMBOL	MOTOROLA PART NO.	DESCRIPTION
L101, 102	24-80065A01	4-1/2 turns; coded RED
L103	24-80065A03	4-1/2 turns; coded YEL
L104, 105	24-82549D29	choke; 1.8 uH
L106	24-82723H04	choke; 0.29 uH
L107	24-83864G12	117 nH (8-1/2 turns); coded RED
L108	24-82835G11	choke; 3.5 uH
L109	24-83961B02	5 turns; coded GRN
L110	24-83397L11	choke; 30 uH
L111	24-83397L08	choke; 15 uH
L112	24-83864G08	73 nH; 5-1/2 turns; coded ORG
L201	24-84419D04	23-1/2 turns
L202	24-83397L07	choke; 10 uH
L203	24-82723H03	choke; 23 uH
L204, 205	24-83397L07	choke; 10 uH
L206	24-82723H03	choke; 23 uH
L207	24-83397L08	choke; 15 uH
L208	24-83397L07	choke; 10 uH
L209	24-82723H03	choke; 23 uH
L210 thru 222	24-83961B01	choke; 3 turns (BRN) (TRN6181A, TRD6182A, TRN6191A, TRD6192A) resistor jumper (TRN6171A, TRD6172A only)
	or 6-11009B23	
		connector, receptacle:
P101	9-82872N01	female
P200, P201	9-83497F05	female; 10-contact (2 ea.)
		transistor: (see note)
Q101	48-869932	NPN; type M9932
Q102	48-869643	PNP; type M9643
Q103	48-869839	field-effect; type M9839
Q104	48-869642	NPN; type M9642
Q105	48-84411L10	PNP; type M1110
Q201	48-869494	NPN; type M9494
Q202	48-869642	NPN; type M9642
Q203	48-869643	PNP; type M9643
		resistor, fixed: ± 5%; 1/4 W; unless otherwise stated
R102	6-11009A13	33
R103	6-11009A57	2.2k
R104	6-11009A45	680
R105	6-11009A24	91
R106	6-11009A71	8.2k
R107	6-11009A73	10k
R108	6-11009A39	390
R109	6-11009A61	3.3k
R110	6-11009A25	100
R111	6-11009A81	22k
R112, 113	6-11009A49	1k
R201	6-11009A79	18k
R202	6-11009A49	1k
R203	6-11009A87	39k
R204	6-11009A37	330
R205	6-11009A11	27
R206	6-11009A54	1.6k
R207	6-11009A93	68k
R208	6-11009A35	270
R209, 210	6-11009A93	68k
R211	6-11009A35	270
R212	6-11009A93	68k
R213	6-11009A41	470
R214, 215	6-11009A89	47k
R216	6-11009A93	68k
R217	6-11009A65	4.7k
R218	6-11009A49	1k
R219	6-11009A91	56k
	or	
R220	6-11009A94	75k (see note 8 on schematic)
R221	6-11009A68	6.2k
R222	6-11009B06	220k
R223	6-11009A73	10k
R224	6-11009A91	56k
R225	6-11009A75	12k
	or	
R226	6-11009A51	1.2k (see note 8 on schematic)
R227	1009A65	4.7k
R228	6-11009A71	8.2k
R229	6-11009A66	5.1k
R230	6-11009A80	20k
	or	
RT201	6-83600K02	thermistor: 1k @ 25°C
		switch:
S201	40-82765M01	spst

REFERENCE SYMBOL	MOTOROLA PART NO.	DESCRIPTION
U201	51-83629M05	integrated circuit: (see note) second i-f amplifier
U202	51-83629M60	quad detector
	or	
	51-84561L84	(see note 8 on schematic)
Y201	48-84396K05	crystal: (see note) 10.7 MHz (TRD6172A, TRD6182A, TRN6171A, TRD6181A)
	or 48-84396K07	10.8 MHz (TRD6192A, TRD6191A)
Y202 thru 205	48-84396K02	10.7 MHz (TRD6172A, TRD6182A, TRD6171A, TRD6181A)
	or 48-84396K06	10.8 MHz (TRD6192A, TRD6191A)
		mechanical parts
	2-80045A01	NUT, retainer; M5 x 0.8; 5 used
	3-3375	SCREW, tapping; 6-20 x 5/16"; 14 used
	3-80012A04	SCREW, set; 5 used
	3-84256M01	SCREW, tapping; 8 used
	5-10277A17	GROMMET, plastic
	5-84220B01	GROMMET, panel; 8 used
	15-80008A01	HOUSING
	26-80062C01	SHIELD, IC
	26-80121A01	SHIELD, can; 5 used
	26-80144B03	SHIELD, mixer
	26-80196A01	SHIELD, coil; 3 used
	26-82868N01	SHIELD, 1st i-f
	26-82870N01	SHIELD, input
	26-84173N01	SHIELD, mag.
	26-82871N01	SHIELD, quad
	26-83264F01	SHIELD, coil; L201
	26-84173N01	SHIELD, magnetic; L201
	26-83347N01	SHIELD, 2nd i-f
	26-83596M01	SHIELD, antenna
	26-84243B03	SHIELD, mixer
	45-83824N01	CARD, ejector; 2 used
	75-05295B01	INSULATOR, xtal; 5 used

note: For optimum performance, diodes, transistors, and integrated circuits must be ordered by Motorola part numbers.

LEGEND
 L = 132-150.8 MHz (HLD4051A)
 H = 146-174 MHz (HLD4052A)

HLD4051A and HLD4052A Preampifier Boards PL-6036-E

REFERENCE SYMBOL	MOTOROLA PART NO.	DESCRIPTION
C151, 152, 153	21-83596E10	capacitor, fixed: 220 pF ± 20%; 500 V
C154H	21-83406D52	2 pF ± 25 pF; 500 V
C154L	21-80067A01	1.5 pF ± .25 pF; 500 V
C155	21-83596E10	220 uF ± 20%; 500 V
C156H		not used
C156L	21-83406D52	2 pF ± .25 pF; 500 V
P112	9-80180B01	connector, receptacle: female; 6 contacts
L151, 152	24-82549D48	coil: choke; 2.2 uH
L153	24-80031A02	5-1/2 turns (coded grn)
Q151	48-869839	transistor: (see note) field-effect; type M9839
R151	6-124A25	resistor, fixed: 100 ± 5%; 1/4 W
R152	6-124A77	15k



MOTOROLA INC.

Communications
Sector

TRANSMITTER

Model Chart for Intermittent Duty Transmitter

Item	Description
TLD2532A	110 W Power Amplifier
TKN8313A	Internal Cable Kit
TFD6452A	Harmonic Filter
TLD9252A	Power Amplifier Board
TLD9272A	Power Control Board
TRN5141A	PA Hardware
TRN5378A	Closing Hardware
TLD9232A	Simplex Exciter Board (Simplex Stations Only)
TLD9242A	Duplex Exciter Board (Duplex Stations Only)

Model Chart for Continuous Duty Transmitter

Frequency Coverage Chart		
Item	Description	Frequency
TLD2601A	100 Watt Power Amplifier Deck	132-150.8 MHz
TLD2602A	100 Watt Power Amplifier Deck	150.8-162 MHz
TLD2603A	100 Watt Power Amplifier Deck	162-174 MHz

Assembly Breakdown Chart

TLD2601A	TLD2602A	TLD2603A	Item	Description
X			TFD6101A	Harmonic Filter, 132-150.8 MHz
	X	X	TFD6102A	Harmonic Filter, 150.8-174 MHz
X			TLD5952A	Power Amplifier Board, 132-150.8 MHz
	X		TLD5953A	Power Amplifier Board, 150.8-162 MHz
		X	TLD5954A	Power Amplifier Board, 162-174 MHz
X	X	X	TLD5960A	Power Control Board
X	X	X	TLN2424A	Power Amplifier Input Bracket Assembly
			includes	TRN5566A PA Input Bracket
			includes	TRN5585A Exciter Control Voltage Regulator
			includes	TKN8336A PA Cable Kit
X	X	X	TRN5577A	PA Casting & Hardware
X	X	X	TRN5586A	PA Hardware
X	X	X	TRN8069A	Suppression Network

PERFORMANCE SPECIFICATIONS

Frequency Separation	3 MHz
Number of Channels	1, 2, 3, or 4
Frequency Stability	± .0005% from -30°C to +60°C (25°C reference) ± .0002% optional*
Power Output	Intermittent duty transmitter: 60 to 110 watts continuously variable, into 50 ohm load (EIA intermittent duty cycle) Continuous duty transmitter: 50 to 100 watts, continuously variable, into 50 ohm load (EIA continuous duty cycle)
Maximum Frequency Deviation	± 5 kHz @ 1 kHz
Sideband Spectrum	± 30 kHz 90 dB below carrier ± 1 MHz 105 dB below carrier
Hum and Noise	55 dB below 60% deviation @ 1 kHz
Audio Response	+1, -3 dB from 6 dB/octave, 300-3000 Hz, referenced to 1000 Hz
Spurious: Conducted Radiated	85 dB below carrier -13 dBm (dipole substitution method)
Audio Distortion	Less than 2% @ 1000 Hz, 60% system deviation

*Available with option C601, C602, C603, or C604.

technical writing services

1. GENERAL

The 110 watt intermittent duty and 100 watt continuous duty transmitters used in the Motorola *MSR 2000* VHF Base Station consist of the exciter board, mounted in the rf control chassis, and the power amplifier enclosed in a casting mounted at the top of the cabinet.

2. EXCITER

2.1 Two versions of the exciter are available. The TLD9230A Series Simplex Exciter is intended for use with stations operating in simplex (non-simultaneous transmit/receive) mode. The TLD9240A Series Duplex Exciter contains additional interconnection filtering, and is intended for use with stations operating in duplex mode, i.e., repeater stations.

2.2 The exciter board is easily accessed for alignment by swinging the rf control chassis out and down. Refer to the Maintenance section of this manual for service access procedures.

3. POWER AMPLIFIER

The TLD2532A and TLD2600A Series Power Amplifiers consist of the power amplifier board, power control board, and harmonic filter, mounted in a rugged aluminum casting. All circuitry is fully shielded, and is easily accessed for alignment and servicing without removing the PA chassis from the base station. Refer to the Maintenance section of this manual for service access procedure.

4. ALIGNMENT

The transmitter alignment procedure involves adjustments on the exciter board and on the power control board. The alignment procedure given is for use with the Motorola TEK-5 Meter Panel, S1056B Test Set, or optional station metering (TRN5080A DC Metering Chassis). When performing a complete alignment, perform the alignment procedures (exciter/PA/power control, oscillator frequency, deviation) in the order given.

INTERMITTENT DUTY TRANSMITTER ALIGNMENT

NOTE

The tuning procedure should be performed using the TRN5080A DC Metering Chassis, Motorola TEK-5 Meter Panel (set to position "D" for exciter or "E" for PA) or Motorola S1056-1059 Portable Test Set (used with TEK-37A Test Set Adapter).

CAUTION

Do not key transmitter for more than a few seconds at a time until it is properly tuned. Key transmitter for brief periods while reading meter and making adjustments.

Exciter-PA Alignment Procedure

Step	Metering Cable Connection	Test Switch Position (Meter)	Adjustment	Procedure
1	None	None	Frequency Select L701-L708 R911,R931, R939 C759	Set to lowest frequency transmit channel (multi-channel radios only). See Prest table Set fully clockwise. Preset fully clockwise
2	Exciter	M1	L701, L702, L703	Peak L702, then peak L701, L702, L703 in order until no further improvement is obtained.
3	Exciter	M1	L704, L705	Dip L704, peak L705.
4	Exciter	M2	L706, L707, L708, L704, L705	Peak L706, L707, L708, L704, L705 in order.
If tuning 1-frequency transmitter, or if overall channel separation is less than 500 kHz, skip to Step 12.				
5	Exciter	M1	L702	Peak on highest frequency channel.
6	Exciter	M2	L704,L706	Peak on highest frequency channel.
7	Exciter	M1	L701,L702	Peak on lowest frequency channel.
8	Exciter	M2	L705, L707	Peak on lowest frequency channel.
9	Transmit Antenna Connector	Wattmeter	C759	Adjust for highest power output at the lowest frequency. If a definite peak is not evident, i.e. if the same amount of power is obtained over a wide range of tuning of C759, turn R931 counter-clockwise until output power drops by 10 watts then peak C759.
10	Exciter	Wattmeter and M2	L708	See R931 fully clockwise. Adjust L708 for equal M2 readings on highest and lowest frequency channels. If balanced M2 readings are not possible, peak L708 on channel with lowest M2 reading.
11	Go to step 15			
12	Transmit Antenna Connector	Wattmeter	C759	Adjust for highest possible power output.
13	Exciter	M2	L707,L708	Peak.
14	Transmit Antenna Connector	Wattmeter	C759	Adjust for highest possible power output. If a definite peak is not evident, i.e. if the same amount of power is obtained over a wide range of turning of C759, turn R931 counter clockwise until power output drops by 10 watts, then peak C759.
15	Transmit Antenna Connector	Wattmeter	R931, R911	Set R931 fully clockwise. Adjust R911 for 120 watts rf output (any channel).
16	Power Control Board J1	M1,M5	Frequency Select	On each channel note M1 and M5 readings for reference.
17	Power Control Board J1	M1	R911,R931	Adjust R911 fully clockwise. On the channel with the highest initial M1, reading, adjust R931 for a reading 4 uA above that recorded in step 16.
18	Power Control Board J1	M5	R939	On the channel with the highest M5 reading, adjust for reading 2 uA above M5 reading recorded in Step 16. If a full 2 uA rise cannot be obtained, return R939 fully clockwise, read M5, and adjust R939 for a 0.5 uA drop in M5 reading.
NOTE: Disconnect test set metering cables before performing Step 19.				
19	Transmit Antenna Connector	Wattmeter	R911	Adjust R911 so that minimum power output is 120 watts on all channels.

COIL PRESET CHART

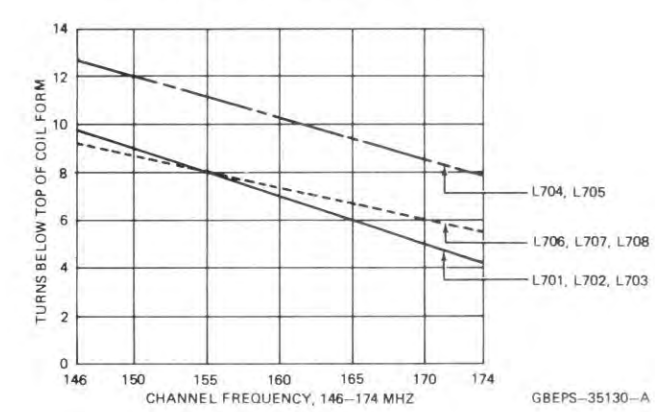

OSCILLATOR FREQUENCY ADJUSTMENT

Setting oscillator frequency should be done *after* exciter/power amplifier alignment, but *before* transmitter deviation is set. To set oscillator on frequency, perform the following procedure:

- Step 1. Select transmitter operating frequency F1. Connect frequency meter to antenna connector via dummy load (refer to instructions provided with meter).
- Step 2. Key transmitter with no modulation.

NOTE

On stations equipped with *Private-Line* or *Digital Private-Line* signaling, the PL/DPL encoder must be disabled. This is accomplished by grounding pin 14 of the PL/DPL board position on the backplane interconnect board.

- Step 3. Adjust F1 FREQ control for proper reading on frequency meter. If the frequency, as indicated on the frequency meter is too low, turn the control counterclockwise. If the frequency is too high, turn the control clockwise. Set frequency within ± 75 Hz.

NOTE

Omit Steps 4 and 5 for 1-frequency stations.

- Step 4. Select transmitter operating frequency F2, and repeat Step 3 using F2 FREQ control.
- Step 5. Repeat Step 4 for F3 and F4 using F3 FREQ and F4 FREQ controls respectively.

INSTANTANEOUS DEVIATION CONTROL (IDC) ADJUSTMENT

NOTE

The oscillator frequency adjustment must be made prior to this adjustment.

- Step 1. Connect the output leads of an audio oscillator, through a .33 uF capacitor, to exciter pins 12 (EXCITER AUDIO HI) and 11 (EXCITER AUDIO LO).
- Step 2. Connect an ac voltmeter across the same terminals and adjust the audio oscillator output to 350 mV rms at 1000 Hz.
- Step 3. Key transmitter and adjust F1 IDC while observing deviation monitor. Adjust control for 4.7 kHz deviation.
- Step 4. Repeat Step 3 for each frequency used, adjusting IDC adjustment corresponding to each channel.

NOTE

If radio set transmits *Private-Line* or *Digital Private-Line* signals, PL/DPL deviation with audio oscillator disconnected should now be between 0.5 and 1.0 kHz.

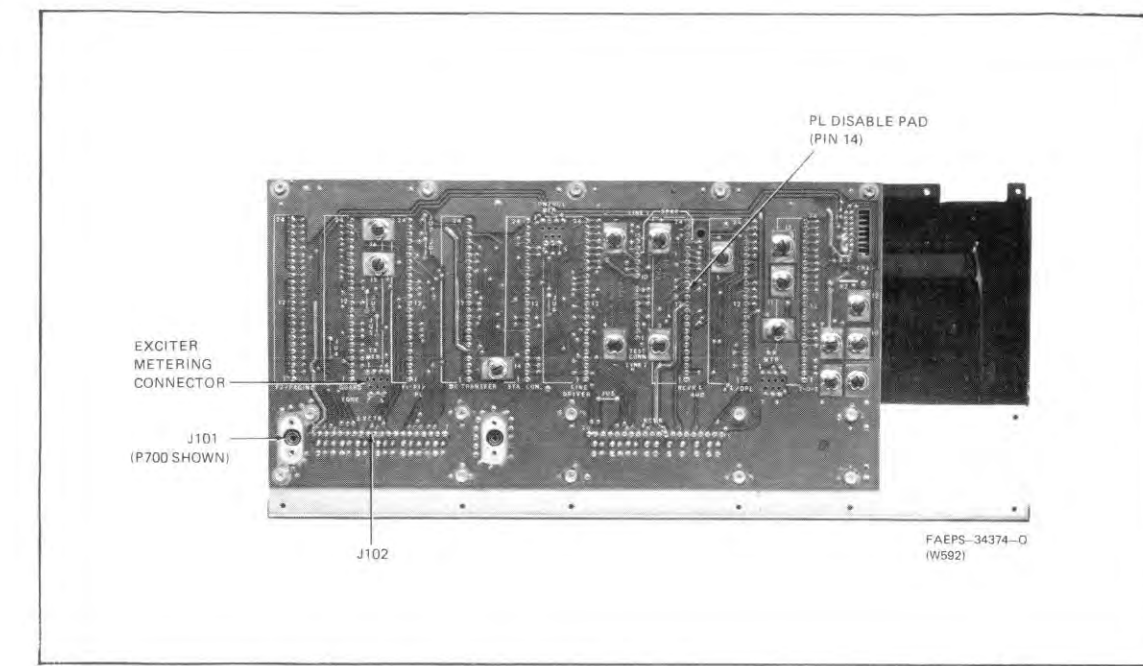

Figure 1. Basic Chassis Exciter Metering Connection Detail

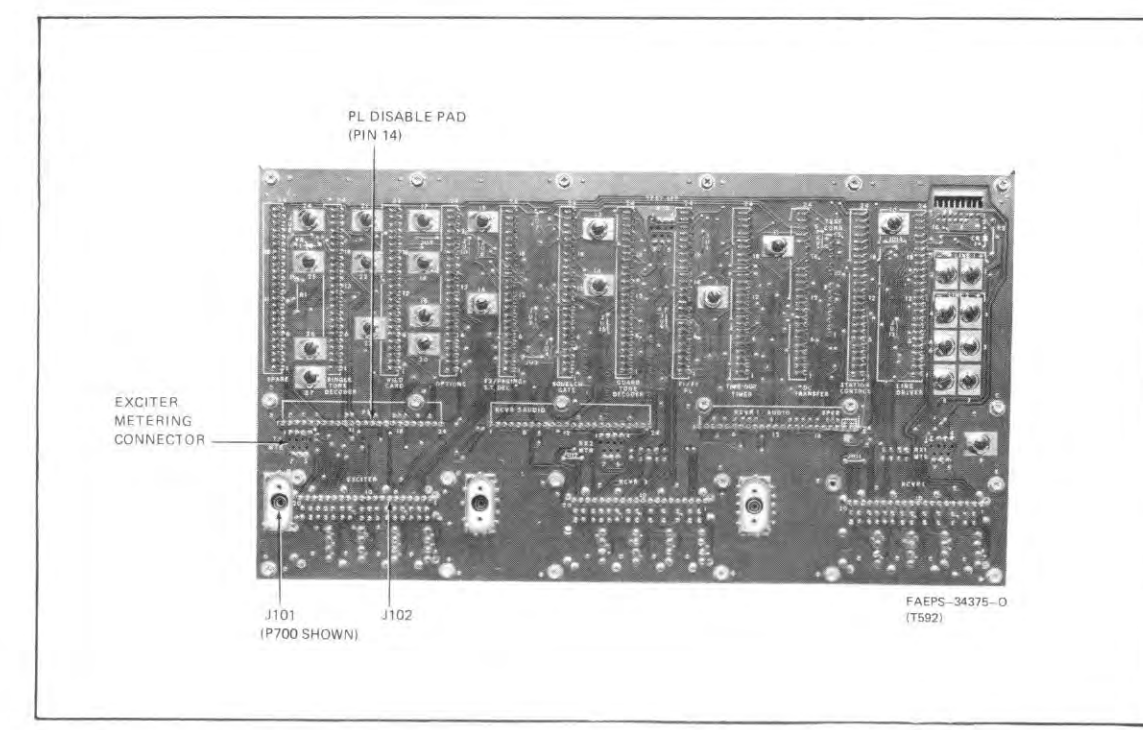

Figure 2. Fully Optionable Chassis Exciter Metering Connection Detail

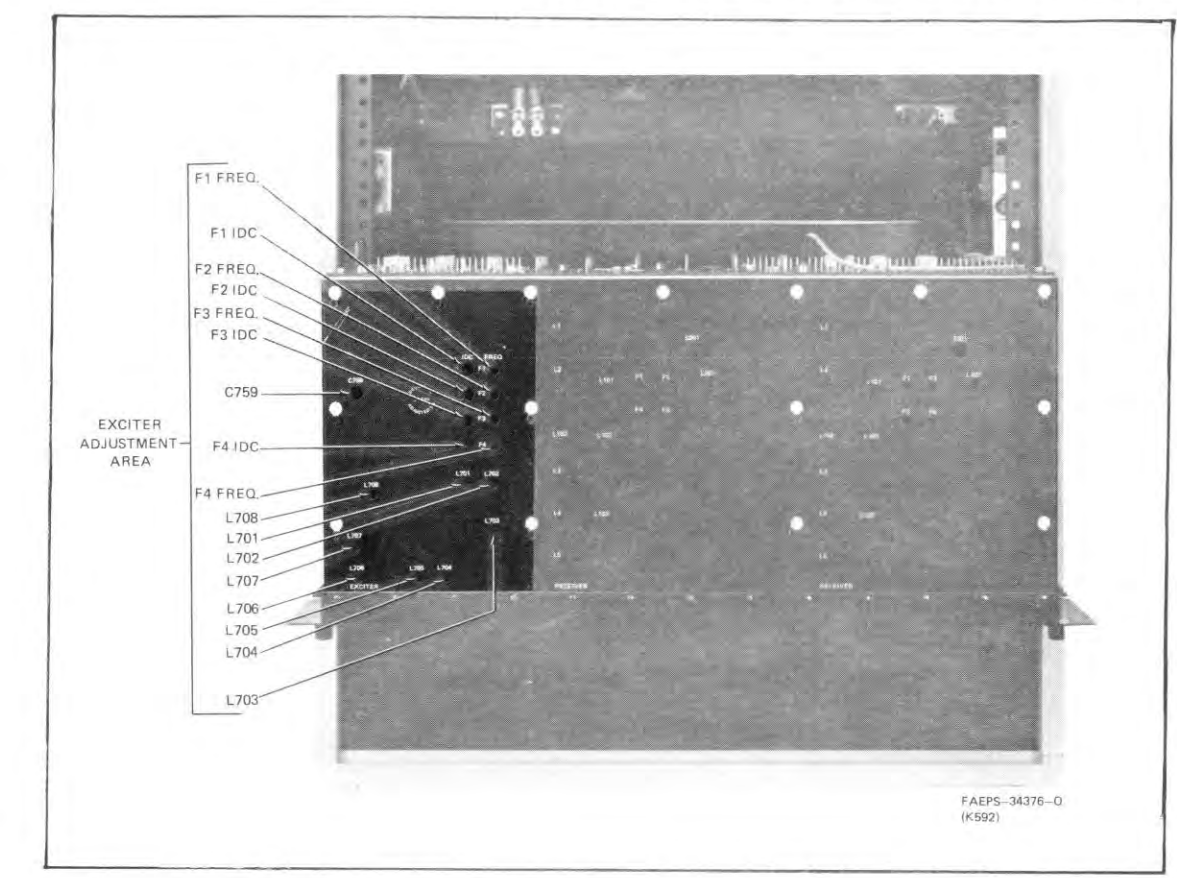

Figure 3. Exciter Adjustment Location Detail

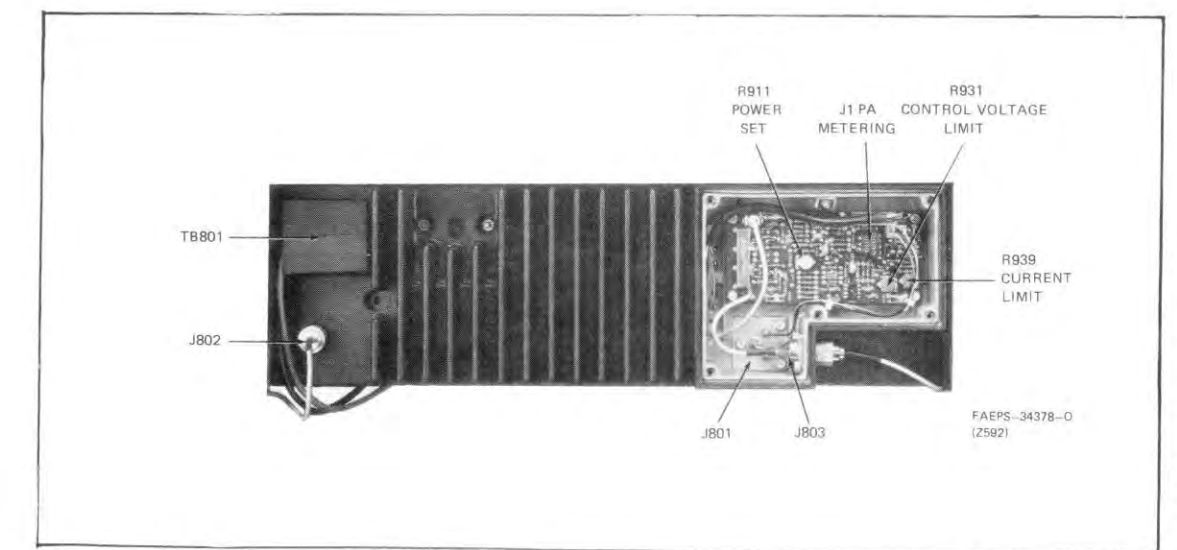
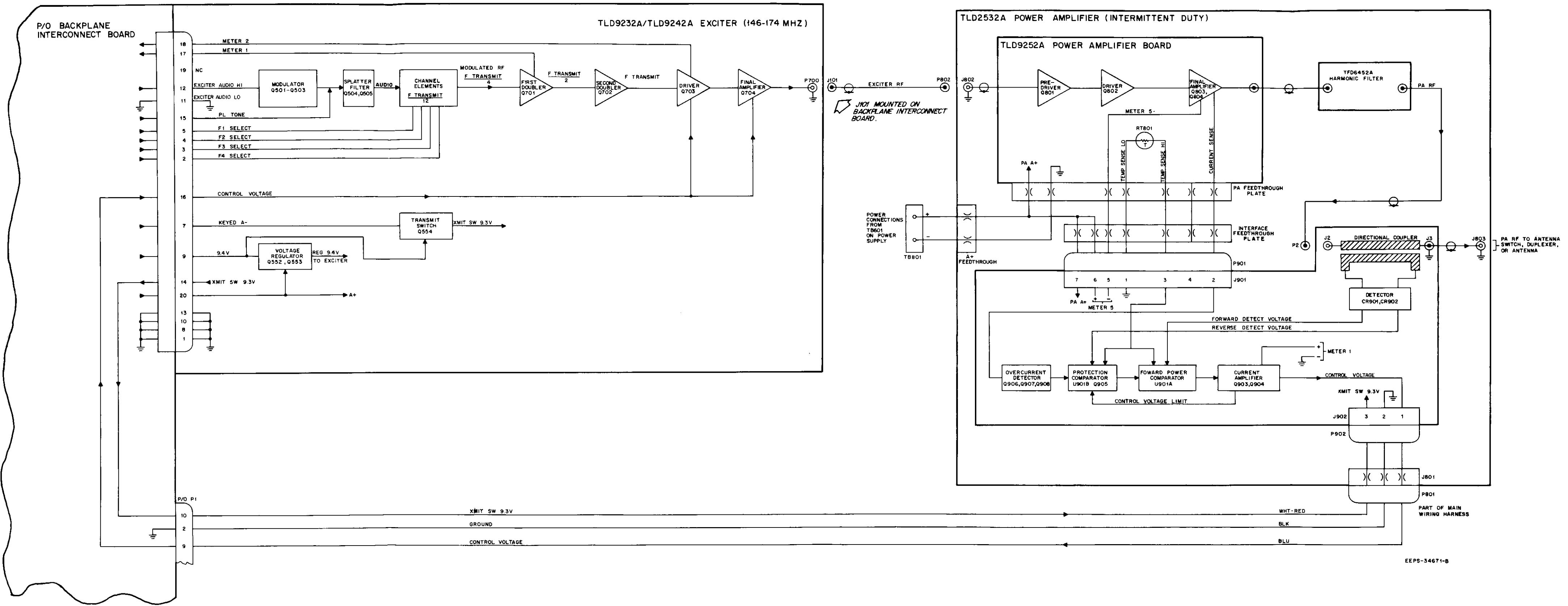

Figure 4. PA Adjustment Location Detail

Intermittent Duty Transmitter Alignment
Motorola No. PEPS-34373-B
11/15/82 - V & G

TRANSMITTER ALIGNMENT



EEPS-34671-B

Intermittent Duty
 Transmitter Functional Interconnect Diagram
 Motorola No. EEPS-34671-B
 11/15/82 - V & G
 4

COIL PRESET CHARTS

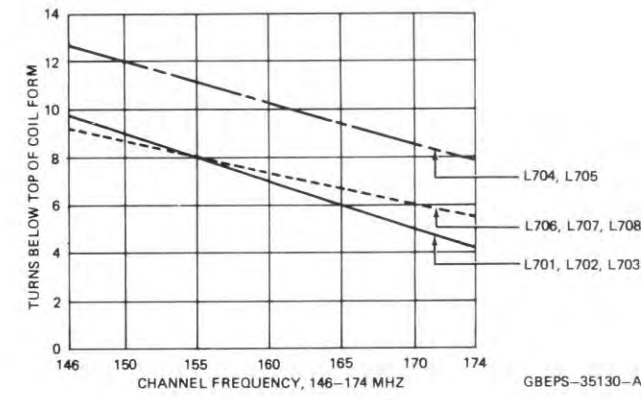
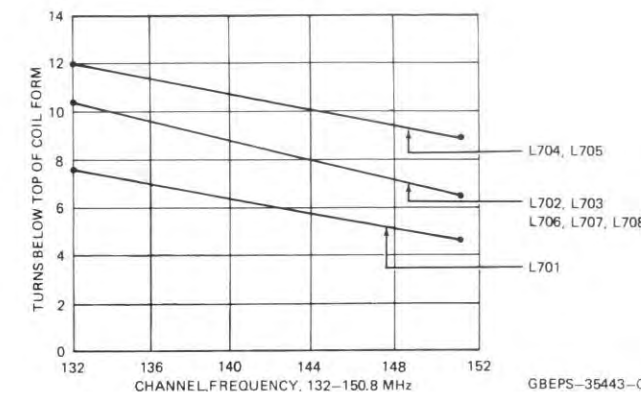

Table 1. Control Voltage Set (R901)

Model	Frequency (MHz)	Voltage*
TLD9231A or TLD9241A	132-141	5.5 V
	141-150.8	6.0 V
TLD9232A or TLD9242A	146-160	6.0 V
	160-174	6.5 V

*Voltage is measured at pin 16 of exciter.

Table 2. Meter Limit Specifications*

Metering Cable Connection	Test Switch Position (Meter)	Min (uA)	Max (uA)
Exciter	M1	10	50
Exciter	M2	15	50
Power Amplifier	M1	10	
Power Amplifier	M2	5	
Power Amplifier	M3	10	
Power Amplifier	M4	10	
Power Amplifier	M5	29	
Power Control Board	M1	15	45
Power Control Board	M2	10	
Power Control Board	M5	50	

*Limit specifications are applicable after the transmitter has been aligned and is operating into a 50 ohm load.

NOTE

The tuning procedure should be performed using the TRN5080A DC Metering Chassis, Motorola TEK-5 Meter Panel (set to position "D" for exciter, "C" for PA, and "E" for Power Control) or Motorola S1056-1059 Portable Test Set (used with TEK-37A Test Set Adapter).

CAUTION

Do not key transmitter for more than a few seconds at a time until it is properly tuned. Key transmitter for brief periods while reading meter and making adjustments.

Exciter-PA Alignment Procedure

Step	Metering Cable Connection	Test Switch Position (Meter)	Adjustment	Procedure
1	None	None	Frequency Select	Turn the FREQUENCY SELECT switch to the lowest frequency channel.
			L701, L702, L703	Preset coil slugs per coil preset chart.
			L704, L705	Preset coil slugs per coil preset chart.
			L706, L707, L708	Preset coil slugs per coil preset chart.
			C759	Preset fully clockwise (CW).
			R611 — Power Set on Power Control Board	Preset fully counterclockwise (CCW).
			R901 — Exciter Level control on power input bracket	Preset fully clockwise (CW).
2	Exciter	M1	L701, L702, L703	Peak L702, then peak L701, L702, L703 in order until no further improvement is obtained.
3	Exciter	M1	L704, L705	Dip L704, then peak L705.
4	Exciter	M2	L706, L707, L708, L704, L705	Peak L706, L707, L708, L704, and L705 in that order.
If transmitter is to be tuned for a single frequency, or frequencies with a separation of less than 500 kHz, skip to Step 12.				
5	None	None	Frequency Select	Turn the FREQUENCY SELECT switch to the highest channel frequency.
6	Exciter	M1	L702	Peak L702.
7	Exciter	M2	L704, L706	Peak L704 and L706.
8	None	None	Frequency Select	Turn the FREQUENCY SELECT switch to the lowest channel frequency.
9	Exciter	M1	L701, L703	Peak L701 and L703.
10	Exciter	M2	L705, L707	Peak L705 and L707.
11	Power Amplifier	M1	C759	Peak C759 (Exciter). If M1 is greater than 50 uA, reduce exciter control voltage (R901) until a peak can be obtained.
12	Exciter (pin 16)	Voltmeter	R901	Set control voltage according to Table 1.
If the transmitter is to be tuned for a single frequency or frequencies with a separation of less than 500 kHz, skip to Step 15.				
13	Exciter	M2	L708	Adjust L708 for equal M2 readings on the lowest channel frequency and on the highest channel frequency. If M2 cannot be equalized, peak L708 on the channel with the lowest M2 reading.
14	Power Amplifier	M1	C759	Peak C759 (exciter) on the lowest channel frequency. If M1 is greater than 50 uA, reduce the exciter control voltage (R901) until a peak is observed. After peaking C759, reset exciter control voltage to the value in Step 12. Then go to Step 17.
15	Exciter	M2	L707, L708	Peak L707 and L708.
16	Power Amplifier	M1	C759	Peak C759 (exciter). If M1 is greater than 50 uA, reduce the exciter control voltage (R901) until a peak can be observed. After peaking C759, reset exciter control voltage to the value in Step 12.
17	Power Amplifier		R611	If power amplifier is to be re-aligned greater than ±1 MHz from original frequency proceed with Step 18. If power amplifier is to be re-aligned less than ±1 MHz from original frequency, remove power control board shield, move metering plug to power control board. Set R611, Power Set, fully clockwise (CW) and go to Step 22.

Exciter-PA Alignment Procedure (Cont'd.)

Step	Metering Cable Connection	Test Switch Position (Meter)	Adjustment	Procedure
18	Power Amplifier		C501, C502, R610	REALIGNMENT — Set cap. C501 fully clockwise. Set cap. C502 to maximum capacity (plates fully meshed). Remove power control board shield and move metering plug to power control board. Use tuning tool Motorola No. 66A82846D01 or equivalent to prealign POWER LIMIT control R610, located on the component side of the board. Access to this control is provided by a small slot located approximately 3/4" from the POWER SET access hole. The tuning tool rotates the outer edge of a serrated knob. Adjust R610, the POWER LIMIT control, to the end of its travel by rotating the edge of the knob toward the front of the station with the PA in the tilted out position.
19	Power Control Board		R611	TRANSMITTER OUTPUT — Adjust R611 (POWER SET) control to maximum clockwise (CW) position.
20	Power Control Board	M5	C501	PA (DRIVER) OUTPUT — Observe M5. If this indication is less than 50 uA (full scale), proceed with Step 21. If this indication is greater than 50 uA tune C501 for on-scale reading.
21	Power Control Board	Wattmeter	R610	TRANSMITTER OUTPUT — Adjust R610 (POWER LIMIT control) toward back of station until either rated power output is attained or no further increase in power output is observed. IN EITHER CASE, adjust POWER LIMIT control for an approximate 5 W to 10 W reduction.
22	Power Control Board	M5	C501, C502	PA DRIVER OUTPUT — Tune C501 then C502 for a minimum M5 reading.
23	Power Control Board	Wattmeter	R610	TRANSMITTER OUTPUT — Adjust the POWER LIMIT control (R610) for 115 W. Repeat Step 22. NOTE: If required output cannot be obtained, repeat Steps 21 and 22.
24	Power Control Board	M5 Wattmeter	R610	Replace the power control board shield. If M5 exceeds 50 uA when shield is replaced, remove shield and adjust POWER LIMIT control (R610) slightly (turn knob toward front of station) until an on-scale reading (50 uA or less) is observed when shield is replaced. Power output shall be at least that specified in Step 23.
25	Power Control Board	Wattmeter	R611	TRANSMITTER OUTPUT — Remove the meter cable and adjust POWER SET control (R611) for rated power output. Repeat Step 22.
26	Power Amplifier	M5		FINAL COLLECTOR CURRENT — Move the metering plug to the PA. Measure the final collector current (Ic). Ic, in amperes is the M5 reading: (0-50) × 1/2.

This completes transmitter tuning. Refer to Table 2 for metering limits.

OSCILLATOR FREQUENCY ADJUSTMENT

Setting oscillator frequency should be done after exciter/power amplifier alignment, but before transmitter deviation is set. To set oscillator on frequency, perform the following procedure:

Step 1. Select transmitter operating frequency F1. Connect frequency meter to antenna connector via dummy load (refer to instructions provided with meter).

Step 2. Key transmitter with no modulation.

NOTE

On stations equipped with Private-Line or Digital Private-Line signaling, the PL/DPL encoder must be disabled. This is accomplished by grounding pin 14 of the PL/DPL board position on the backplane interconnect board.

Step 3. Adjust F1 FREQ control for proper reading on frequency meter. If the frequency, as indicated on the frequency meter is too low, turn the control counterclockwise. If the frequency is too high, turn the control clockwise. Set frequency within ± 75 Hz.

NOTE

Omit Steps 4 and 5 for 1-frequency stations.

Step 4. Select transmitter operating frequency F2, and repeat Step 3 using F2 FREQ control.

Step 5. Repeat Step 4 for F3 and F4 using F3 FREQ and F4 FREQ controls respectively.

INSTANTANEOUS DEVIATION CONTROL (IDC) ADJUSTMENT

NOTE

The oscillator frequency adjustment must be made prior to this adjustment.

Step 1. Connect the output leads of an audio oscillator, through a .33 uF capacitor, to exciter pins 12 (EXCITER AUDIO HI) and 11 (EXCITER AUDIO LO).

Step 2. Connect an ac voltmeter across the same terminals and adjust the audio oscillator output to 350 mV rms at 1000 Hz.

Step 3. Key transmitter and adjust F1 IDC while observing deviation monitor. Adjust control for 4.7 kHz deviation.

Step 4. Repeat Step 3 for each frequency used, adjusting IDC adjustment corresponding to each channel.

NOTE

If radio set transmits Private-Line or Digital Private-Line signals, PL/DPL deviation with audio oscillator disconnected should now be between 0.5 and 1.0 kHz.

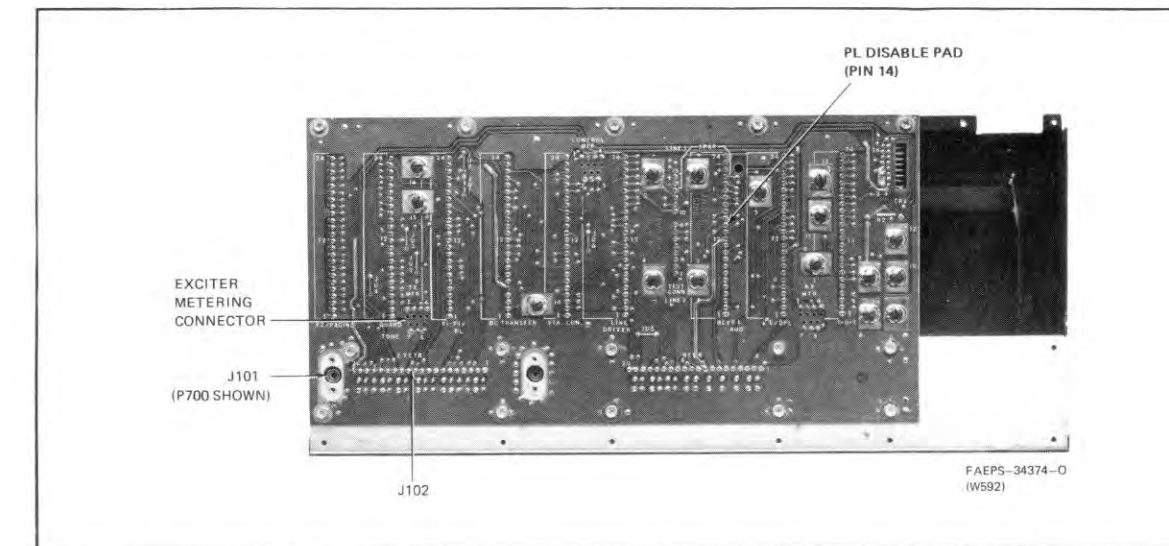

Figure 1. Basic Chassis Exciter Metering Connection Detail

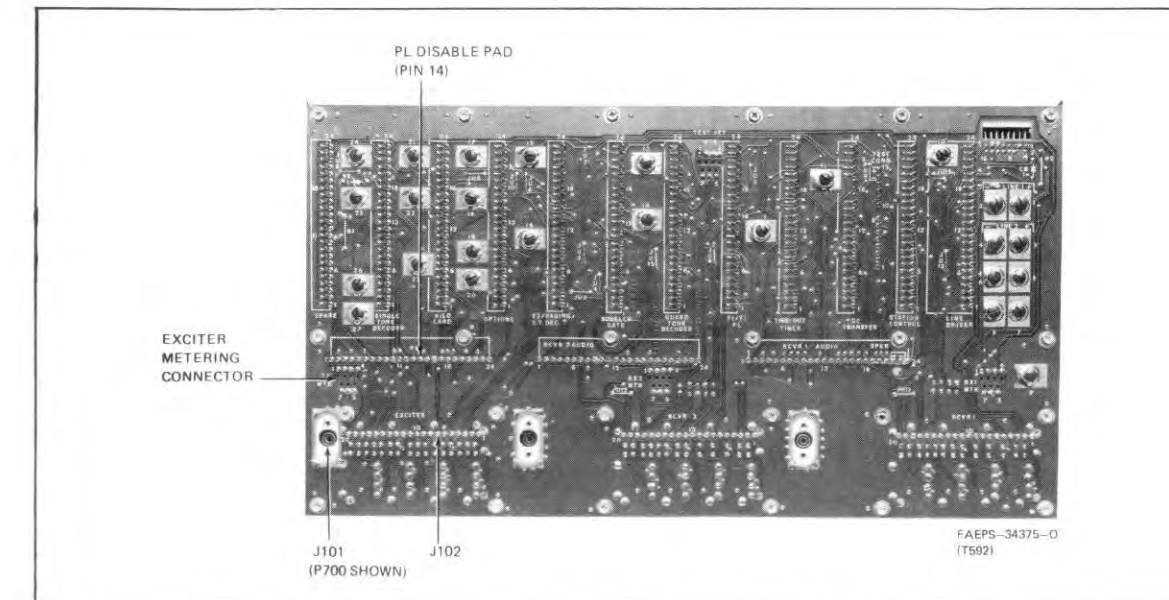

Figure 2. Fully Optionable Chassis Exciter Metering Connection Detail

CONTINUOUS DUTY TRANSMITTER ALIGNMENT

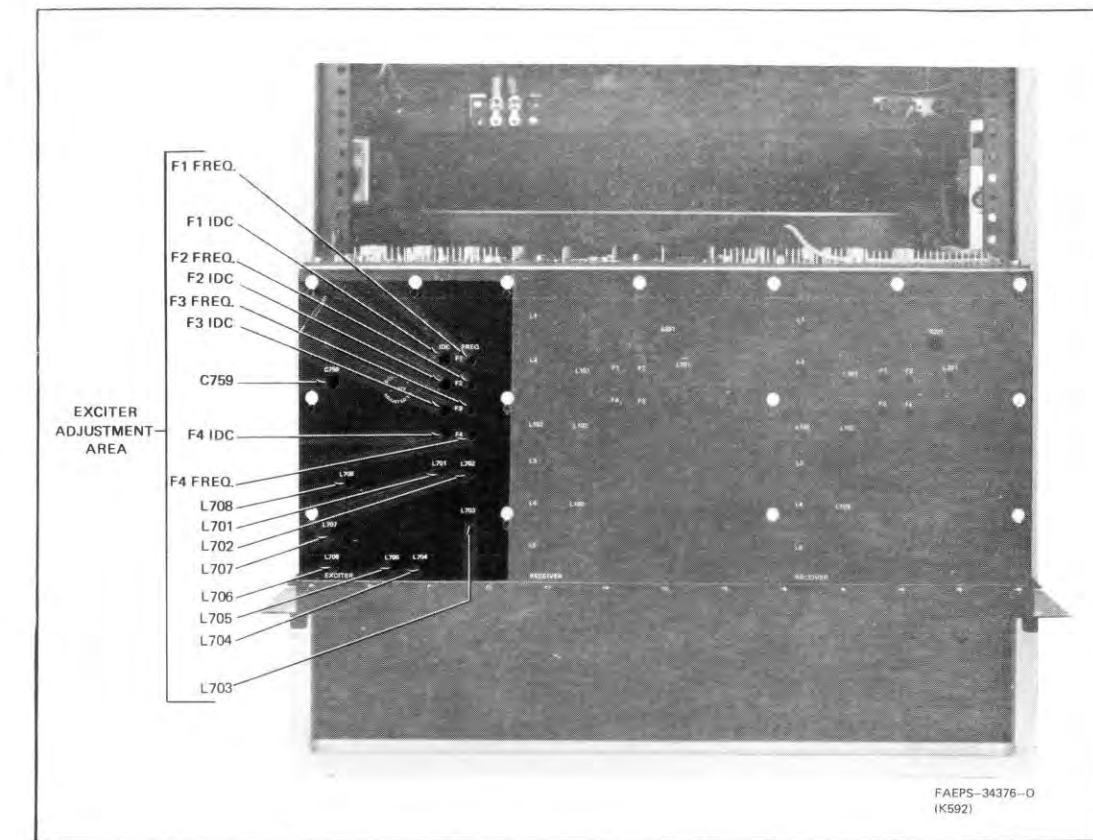

Figure 3. Exciter Adjustment Location Detail

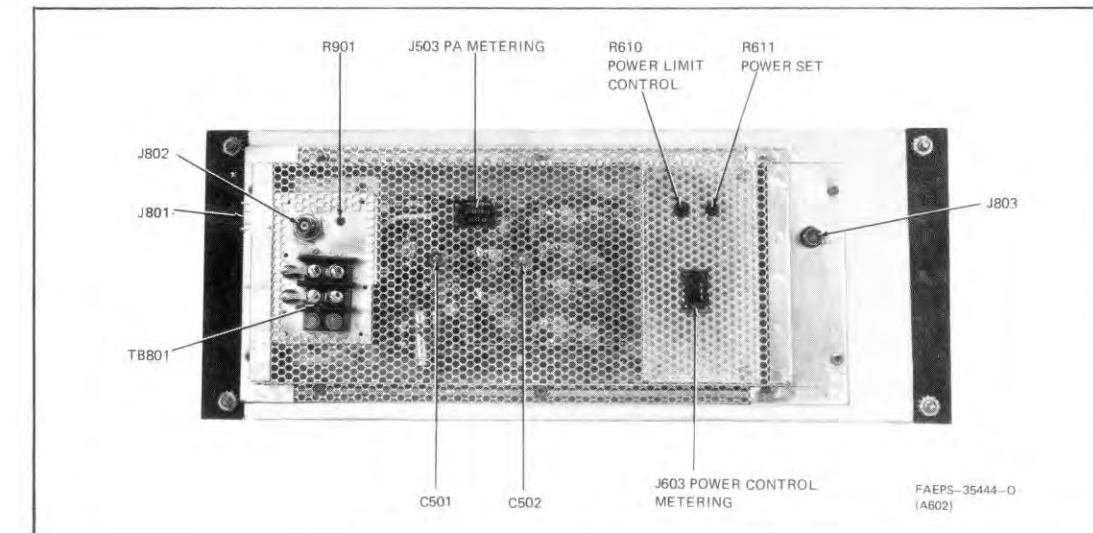
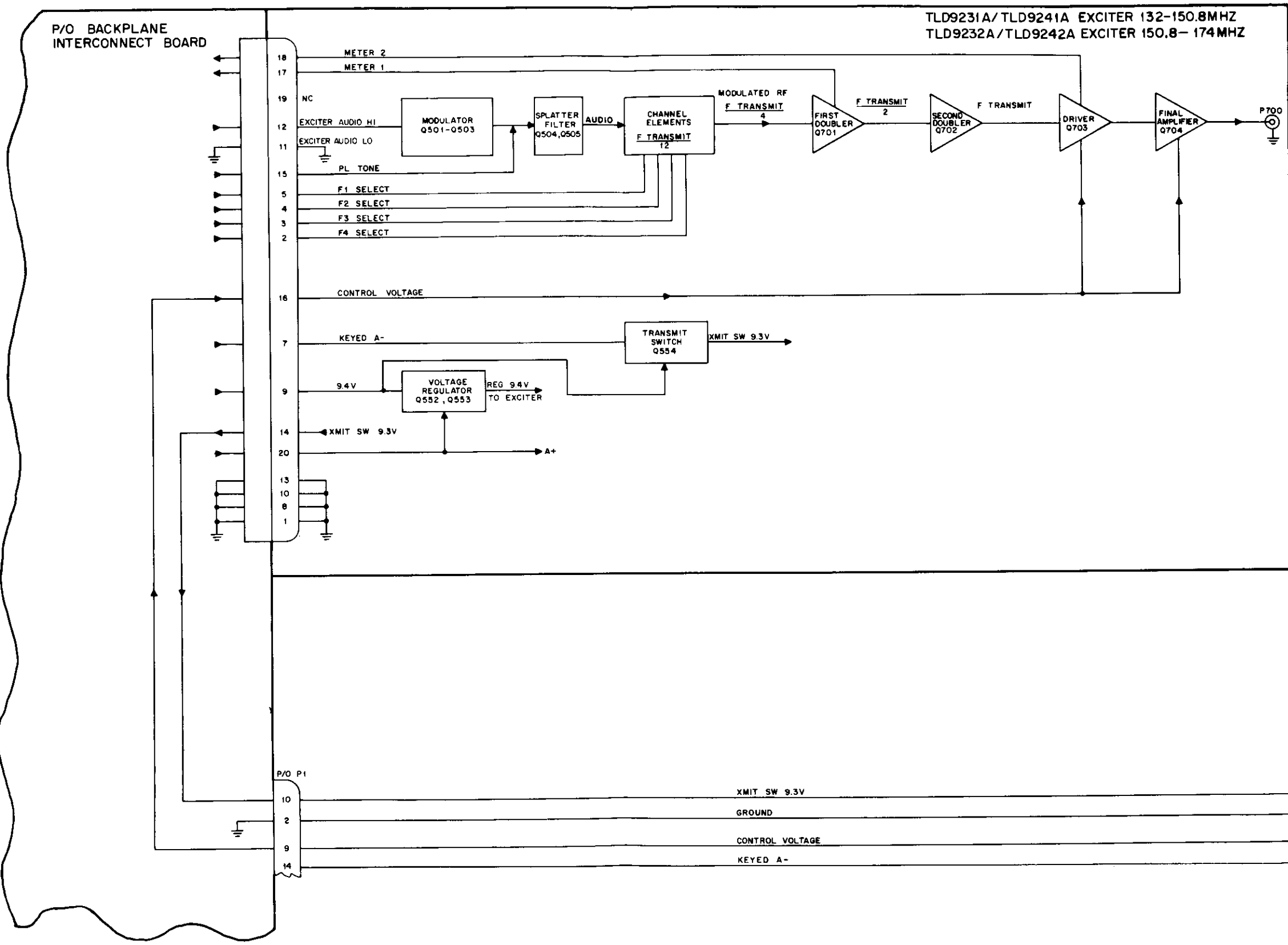
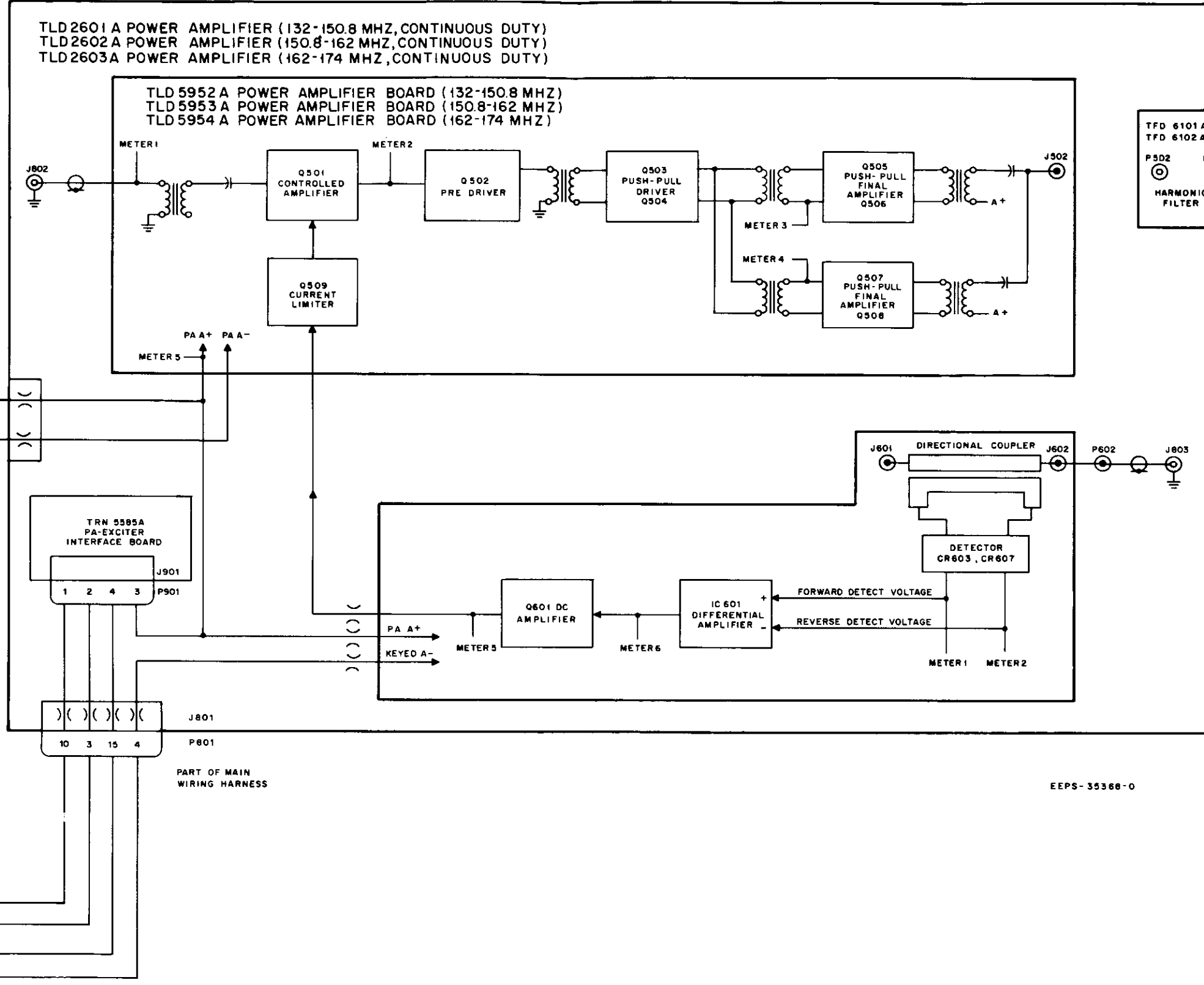

Figure 4. PA Adjustment Location Detail

Continuous Duty Transmitter Alignment
Motorola No. PEPS-35367-O
11/15/82 - V & G



J101 MOUNTED ON BACKPLANE INTERCONNECT BOARD.



Continuous Duty
Transmitter Functional Interconnect Diagram
Motorola No. EEPS-35368-0
11/15/82 - V & G



MOTOROLA INC.

Communications
Sector

EXCITER

MODELS TLD9231A AND TLD9232A SIMPLEX
TLD9241A AND TLD9242A DUPLEX

1. DESCRIPTION

1.1 The Model TLD9230A Series or TLD9240A Series Exciters provide the low power excitation for the FM transmitter. Up to four plug-in channel elements, one for each transmitter operating frequency, are used to develop a direct FM carrier signal of at least 1.5 watts.

1.2 The exciter is direct frequency-modulated for crystal-controlled frequency operation in the 132-174 MHz range. It consists of a modulator amplifier and clipper, emitter-follower splatter filter, channel element(s) (voltage-controlled crystal oscillator), first doubler, second doubler, driver, and final amplifier. The fundamental crystal frequency is multiplied by twelve to provide the transmitter carrier frequency.

1.3 When the exciter is used in PL/DPL coded stations, the PL/DPL encoding signals are inserted into the transmit audio at the input to the splatter filter stage.

2. THEORY OF OPERATION

Refer to the transmitter functional block diagram (in Transmitter section of this manual) and the exciter schematic diagram included in this section.

2.1 TRANSMIT AUDIO CIRCUIT

Exciter audio from the station control module (or test microphone) is applied to audio amplifier Q501, then routed to the clipper/pre-emphasis circuit of Q502 and Q503. This amplitude limited audio is combined with the PL or DPL code audio (if present) and routed via active splatter filter Q504-Q505, to the channel element(s).

2.2 CHANNEL ELEMENTS

2.2.1 Each channel element is comprised of a highly stable, frequency modulated crystal controlled oscillator. The channel element is a factory-sealed plug-in module, using an unheated crystal in an oscillator circuit that is temperature-compensated over an ambient

temperature range of -30°C to $+60^{\circ}\text{C}$ (-22°F to $+140^{\circ}\text{F}$). The oscillator operates at 1/12 of the transmitted carrier frequency.

2.2.2 The channel element contains a series combination of a varactor diode, a warping coil, and the crystal. A change in the series inductance or capacitance causes the crystal to vary its resonant frequency in proportion to the change. The audio voltage from the IDC circuitry (within the channel element) is applied to the varactor diode to cause a change in capacitance; this variation causes the carrier frequency to change (deviate) at the same audio rate. The variable warp coil and IDC potentiometer are accessible through holes in the top of each channel element, for fine frequency and IDC adjustments.

2.2.3 The exciter accepts up to four channel elements; one is required for each transmit frequency. A power input of +9.4 volts is applied continuously to all channel elements while the station is turned on. Channel element output is developed when a switched ground from the station control module is routed to the enable pin.

2.3 MULTIPLIERS AND AMPLIFIERS

2.3.1 The multipliers develop an output signal that is 12 times the channel element frequency, and the final amplifier provides power gain, as controlled by the power control board on the power amplifier.

2.3.2 The output of the activated channel element is routed through three tuned circuits in series. The tuned circuits (L701, L702, L703, and associated components) are tuned to the approximate third harmonic of the channel element frequencies. The signal from the tuned circuit is routed to first doubler Q701. First doubler Q701 and second doubler Q702 multiply the filtered output to 12 times the crystal frequency.

2.3.3 Driver and final amplifier Q703 and Q704 provide two stages of amplification at the transmit frequency. The power output level of the driver and final amplifier is controlled by varying the dc collector

technical writing services

voltage on the transistors. For intermittent duty stations, the CONTROL VOLTAGE is developed on the power control board in the power amplifier. The CONTROL VOLTAGE changes as required to maintain correct PA output level and operating parameters. For continuous duty stations, the CONTROL VOLTAGE is developed on the exciter control voltage regulator board. The CONTROL VOLTAGE is set by the Exciter Level Control (R901).

3. EXCITER FUNCTIONAL TESTS

The tests in this section should be performed *after* servicing but *before* alignment, to verify that the exciter circuitry is operating correctly.

3.1 EXCITER POWER OUTPUT TEST

3.1.1 Intermittent Duty Station

Step 1. Disconnect exciter output cable from power amplifier chassis, and connect to rf wattmeter and dummy load.

Step 2. Set Power Set (R911) and Current Limit (R939) controls to mid-rotation. These controls are located on the power control board in the PA chassis. (Refer to Power Amplifier section for exact location.)

Step 3. Set Control Voltage Limit (R931) fully clockwise. This control is also located on the power control board.

Step 4. Key transmitter and observe wattmeter. Power output is normally at least 1.5 watts.

3.1.2 Continuous Duty Station

Step 1. Disconnect exciter output cable from power amplifier chassis, and connect to rf wattmeter and dummy load.

Step 2. Set Exciter Level Control (R901) fully clockwise (CW). This control is located on the power amplifier.

Step 3. Key the transmitter and observe the wattmeter. Power output is normally at least 0.75 watts.

3.2 FREQUENCY TEST

Step 1. Terminate the transmitter in an antenna or dummy load and measure the radiated signal frequency with a Motorola digital frequency meter or other highly accurate frequency measuring device ($\pm .00005\%$ or better) when the transmitter is keyed in the following steps.

Step 2. Key the transmitter to produce an unmodulated carrier signal. In stations equipped with PL or DPL signaling, disable the encoder by shorting the disable pin to ground (pin 14 on the PL/DPL position on the backplane interconnect board).

NOTE

Do not use microphone push-to-talk switch to key station. Background noise can modulate the transmitter.

Step 3. Read transmitter output frequency. Repeat for each channel on multi-frequency stations.

3.3 DEVIATION TEST

Step 1. Terminate transmitter with an antenna or dummy load and measure the radiated signal deviation using a Motorola deviation monitor when the transmitter is keyed in the following steps.

Step 2. (PL/DPL models only.) Remove PL/DPL inhibit jumper (if installed during previous test). Key transmitter without voice modulation. Normal PL/DPL deviation is 0.5 to 1 kHz.

Step 3. Connect audio oscillator to exciter board pins P501-12 (EXCITER AUDIO HI) and P501-11 (EXCITER AUDIO LO). Set audio oscillator to 1000 Hz at 1 volt output. Normal deviation is 4.7 kHz.

Step 4. Adjust audio oscillator over 300-3000 Hz range, keeping audio level at 1 volt. Normally, deviation never exceeds ± 5 kHz, nor is less than ± 2.5 kHz.

4. TROUBLESHOOTING

Refer to Table 1 for exciter troubleshooting procedure.

Table 1. Exciter Troubleshooting Procedure

Problem	Cause	Remedy
No Voltage at Exciter	1. Exciter not energized	1. Check exciter control circuit for proper operation
	2. No KWH-Exciter Supply IV	2. Check the position of Break 1. Check exciter QPS
	3. No KWH-IV	3. Check position of QPS
	4. No Exciter Breaker	4. Exciter Breaker should be closed
Low Voltage at Exciter	1. QPS, IV, IVI, IVII not energized	1. Perform Exciter PA Adjustment
	2. No QPS, QPSI, and IVI QPSII	2. Check and adjust
	3. Exciter control circuit	3. Troubleshoot PA Factor Control Board or Exciter Control Board Regulator Board
Exciter Not Output Power	1. No QPS	1. Check and adjust
	2. Improper exciter voltage	2. Troubleshoot PA Factor Control Board or Exciter Control Board Regulator Board
	3. No exciter IVI	3. Check for proper position of exciter
Exciter Not Functioning	1. No QPS	1. Check and adjust
	2. Wrong exciter breaker	2. Check that breaker is not open. Check that exciter QPS is closed

EARLIER VERSION EXCITER

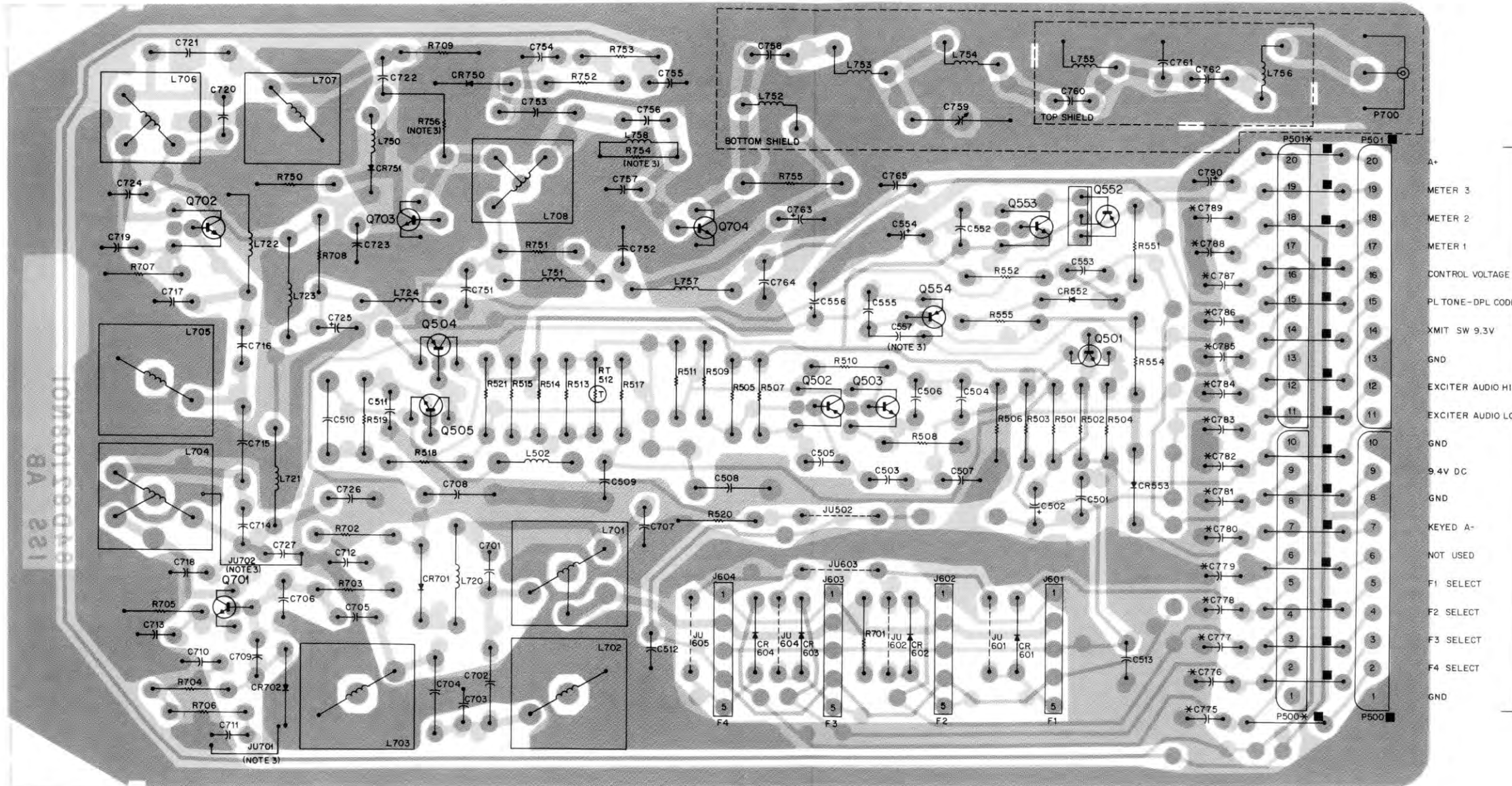

TRANSISTOR BASE DETAILS
(SHOWN FROM COMPONENT SIDE)

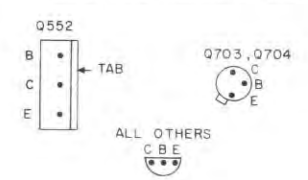

MATES WITH
BACKPLANE
EXCITER
CONNECTOR
J102

- NOTE:
- COMPONENTS DESIGNATED WITH ASTERISK (*) ARE PRESENT ON DUPLEX MODELS (TLD9242A) ONLY.
 - COMPONENTS AND JUMPERS DESIGNATED WITH SQUARE (■) ARE PRESENT ON SIMPLEX MODELS (TLD9232A) ONLY.
 - C557, R754, R756, JU701, AND JU702 ARE LOCATED ON SOLDER SIDE.

SHOWN FROM COMPONENT SIDE

SOLDER SIDE: BD-EEPS-34369-0
COMPONENT SIDE: BD-EEPS-34368-0
QL-EEPS-34370-A

TLD9231A and TLD9232B Simplex Exciter and
TLD9241B and TLD9242C Duplex Exciter
Circuit Board Detail
Motorola No. PEPS-34789-D
(Sheet 1 of 3)
9/13/84 - V & G

EXCITER

parts list

TLD9231A/TLD9232B Simplex Exciter
 TLD9241B/TLD9242C Duplex Exciter
 PL7934-D

REFERENCE SYMBOL	MOTOROLA PART NO.	DESCRIPTION
C501	21-11015B05	capacitor, fixed: uF ± 5%; 50 V; unless otherwise stated
C502	23-11019A09	220 pF ± 10%; 100 V
C503, 504	8-11017B14	1 ± 20%
C505, 506, 507	21-11015B05	220 pF ± 10%; 100 V
C508	8-83813H14	0.43 uF, 5%; 50 V
C509	8-11017A08	.01
C510	8-83813H24	.036
C511	8-11017A01	.001
C512	21-11015B05	220 pF ± 10%; 100 V
C513	21-11021H03	.01 ± 80-20%; 50 V (TLD9231A, 32A only)
C513	23-11019A09	1 ± 20%; 50 V (TLD9241, 42A only)
C551, 552, 553	21-11015B13	.001 ± 10%; 100 V
C554	23-11019A46	100 ± 20%; 25 V
C555	21-11015B13	.001 ± 10%; 100 V
C556	23-11019A46	100 ± 20%; 25 V
C557	21-11021H03	.01 ± 80-20%
C701L	21-11022G48	56 pF
	or 21-11014H43	56 pF, 100 V
C701H	21-11022G44	39 pF
C702L	21-82450B18	2 pF, 500 V
C702H	21-82450B13	5 pF, 500 V
C703L	21-11022G50	68 pF
	or 21-11014H45	68 pF, 100 V
C703H	21-11022G46	47 pF
C704L	21-82450B18	2 pF, 500 V
C704H	21-82450B13	1.5 pF, 500 V
C705	21-11022G57	120 pF
C706L	21-11022E57	120 pF
C706H	21-11022G50	68 pF
C707	21-11015B13	.001 ± 10%; 100 V
C708	21-82372C09	0.1 ± 80-20%; 25 V
C709	21-11022G30	10 pF
C710	21-11015B13	.001 ± 10%; 100 V
C711	21-11021H03	.01 ± 80-20%; 50 V
C712	21-11015B13	.001 ± 10%; 100 V
C713L	21-11021F04	.01 uF
C713H	21-11015B13	.001 uF ± 10%; 100 V
C714L	21-11022G38	22 pF
C714H	21-11022K23	16 pF
C715L	21-82450B13	1.5 pF, 500 V
C715H	21-82450B39	0.5 pF, 500 V
C716L	21-11022G43	36 pF
C716H	21-11022G40	27 pF
C717	21-82810C20	82 pF
C718, 719	21-11015B13	.001 ± 10%; 100 V
C720L	21-11022G33	13 pF
	or 21-11014H28	13 pF, 100 V
C720H	21-11022G27	9 pF ± 0.5 pF
C721L	21-82450B19	1.8 pF, 500 V
C721H	21-82450B47	1 pF, 500 V
C722L	21-11022G33	13 pF ± 0.5 pF
C722H	21-11022G30	10 pF ± 0.5 pF
C723L	21-11022G34	15 pF
C723H	21-11022G31	11 pF
C724	21-11015B15	.0015
C725	23-11019A20	10 ± 10%; 25 V
C726	21-82372C10	.05 ± 20%; 25 V
C727	21-11015B05	220 pF ± 10%; 100 V
C750L	21-11022G38	22 pF
C751	21-11022G59	150 pF
C752	21-11021H03	.01 ± 80-20%; 50 V
C753	21-82450B46	0.62 pF, 500 V
C754	21-11015B13	.001 ± 10%; 100 V
C755	21-11021H03	.01 ± 80-20%; 50 V
C756L	21-82810C74	13 pF, N150
C756H	21-80171A25	9.1 pF ± 25 pF
C757L	21-11022G48	56 pF
	or 21-11014H43	56 pF, 100 V
C757H	21-11022G47	51 pF
C758	21-11015B05	220 pF ± 10%; 100 V
C759	20-84579B11	variable; 7.57 pF
C760L	21-11022G25	8 pF ± 0.5 pF
	or 21-851846	8 pF ± .25 pF
C760H	21-11022G20	6 pF ± 0.5 pF
C761L	21-11022G47	51 pF
C761H	21-11022G44	39 pF
C762L	21-11022G25	8 pF ± 0.5 pF
	or 21-851846	8 pF ± .25 pF
C762H	21-11022G20	6 pF ± 0.5 pF
C763	23-84538G06	47 ± 20%; 20 V
C764, 765	21-11021H03	.01 ± 80-20%
C774	8-11017B17	0.1 ± 10%
C775 thru 789	21-11015B13	.001 ± 10%; 100 V (TLD9242B, 41A only)
C790	23-11019A09	1 ± 20%
		diode: (see note)
CR552	48-83654H02	silicon
CR553	48-83654H01	silicon
CR601 thru 604	48-83654H01	silicon
CR701	48-82466H13	silicon
CR702	48-83654H01	silicon

REFERENCE SYMBOL	MOTOROLA PART NO.	DESCRIPTION
CR750	48-83654H01	silicon
CR751	48-82139G01	germanium
J601 thru 604	28-80096A02	connector, receptacle: male, 5-contact
L502	24-80036A02	coil, rf: choke; 1/2 turn
L701	24-83373J11	choke; 6-1/2 turns coded (VIO)
L702, 703	24-80068A17	6-1/2 turns, coded (VEL)
L704	24-80068A18	4-1/2 turns, coded (ORG)
L705	24-80068A19	4-1/2 turns, coded (WHT)
L706	24-80034A02	3-1/2 turns, coded (WHT)
L707	24-80034A03	3-1/2 turns, coded (RED)
L708	24-80034A01	3-1/2 turns, coded (ORG)
L720, 721	24-82835G13	choke; 0.82 uH
L722	24-82723H04	0.29 uH
L723	24-82835G13	choke; 0.82 uH
L724	24-83961B01	3-1/2 turns
L750	24-82723H27	choke; 1.2 uH
L751	24-82835G13	choke; 0.82 uH
L752	24-84411B03	11-1/2 turns, coded (BRN)
L753	24-83846G01	3-1/2 turns, coded (PNK)
L754	24-84411B04	10-1/2 turns, coded (ORG)
L755	24-83846G07	2-1/2 turns, coded (GRN)
L756	24-84411B04	10-1/2 turns, coded (ORG)
L757	24-82835G13	choke; 0.82 uH
L758	24-83961B07	choke; 2 turns
L759	24-83861B01	choke; 3 turns; (TLD9231A, 32A only)
P500, 501	28-83254N01	connector, plug: male; 10-contact (TLD9242B, 41A only)
	9-82497F05	female; 10-contact (TLD9232B, 31A only)
P700	9-82872N01	female; phono
		transistor: (see note)
Q501	48-869642	NPN, type M9642
Q502	48-869643	PNP, type M9643
Q503	48-869642	NPN, type M9642
Q504	48-869643	PNP, type M9643
Q505	48-869642	NPN, type M9642
Q552	48-84411L10	PNP, type M1110
Q553	48-869642	NPN, type M9642
Q554	48-869649	PNP, type M9649
Q701	48-869494	NPN, type M9494
Q702	48-869638	NPN, type M9638
Q703	48-869657	NPN, type M9657
Q704	48-869659	NPN, type M9659
		resistor, fixed: ± 5%; 1/4 W; unless otherwise stated
R501	6-11009A65	4.7k
R502	6-11009A57	2.2k
R503	6-11009A27	120
R504	6-11009A25	100
R505, 506	6-11009A83	27k
R507, 508	6-11009A13	33
R509, 510	6-11009A93	68k
R511	6-10621B94	1000 precision
R513	6-11009A85	33k
R514	6-11009A73	10k
R515	6-11009A73	10k
R516	6-11009A73	10k
R517	6-11009A63	3.9k
R518, 519	6-10621C75	6.8k ± 1%
R520	6-11009A43	560
R521	6-11009A83	27k
R551, 552	6-11009A48	910
R554	6-11009A59	2.7k
R555	6-11009A73	10k
R701	6-11009A65	4.7k
R702	6-11009A92	62k
R703	6-11009A49	1k
R704	6-11009A79	18k
R705L	6-11009A13	33
R705H	6-11009A05	15
R706L	6-11009A81	22k
R706H	6-11009A83	27k
R707	6-11009A17	47
R708L	6-11009A23	82
R708H	6-11009A25	100
R709	6-11009A57	2.2k
R710	6-11009A25	100
R711	6-11009A57	2200
R712	6-11009A73	10k
R750	6-11009A37	330
R751	6-11009A17	47
R752L	6-11009A90	51k
R752H	6-11009A93	68k
R753L	6-11009A90	51k
R753H	6-11009A93	68k
R754	6-11009A99	222

REFERENCE SYMBOL	MOTOROLA PART NO.	DESCRIPTION
R755	6-125C31	180 ± 10%; 1/2 W
R756	6-11009A57	2.2k
R756L	6-11009A49	1k
R756H	6-11009A57	2.2k
R757L	6-11009E33	220
RT512	6-84259H02	thermistor: 44k ± 10% @ 25 °C
		mechanical parts
3-84256M01		SCREW, tapping; 2 used
5-84220B01		GROMMET; 2 used
6-11009B23		JUMPERS; 15 used (TLD9232B, 31A only)
14-861196		INSULATOR; 2 used
26-80039A01		CAN, coil; 3 used
26-80150B01		HEAT SINK Q704
26-80196A01		CAN, coil; 5 used
26-83283N01		SHIELD, exciter top
26-83284N01		SHIELD, exciter bottom
42-82160N01		CLIP, shield mounting; 3 used
45-83824N01		EJECTOR, card; 2 used
5-84220B01		GROMMET; 2 used
42-82160N01		CLIP, shield mounting; 3 used
		note: For optimum performance, diodes, transistors, and integrated circuits must be ordered by Motorola part numbers.

LATER VERSION EXCITER
 EXCITER

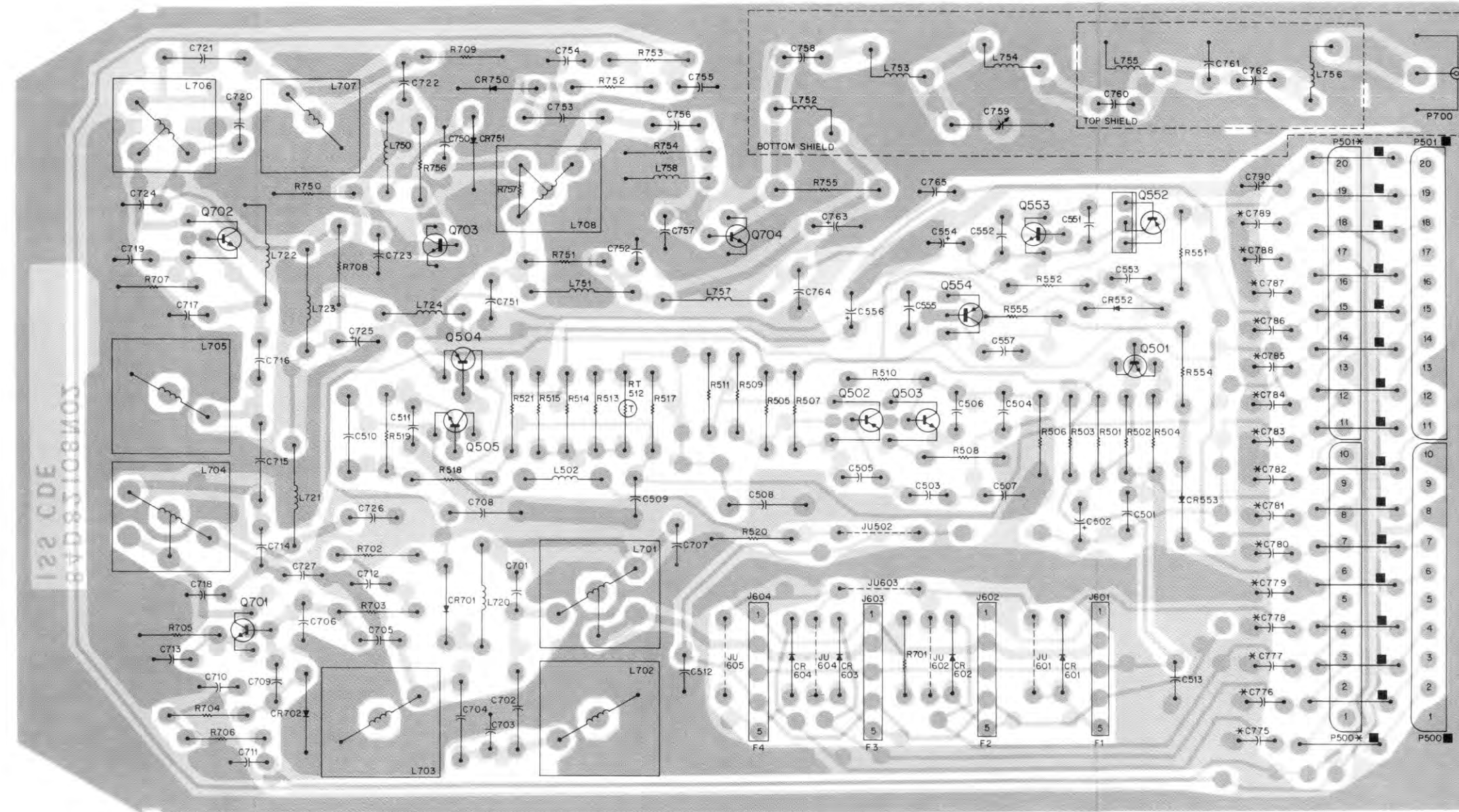

SHOWN FROM COMPONENT SIDE

SOLDER SIDE: BD-DEPS-35241-D
 COMPONENT SIDE: BD-DEPS-35242-C
 OL-EEPS-35243-G

TRANSISTOR BASE DETAILS (SHOWN FROM COMPONENT SIDE)

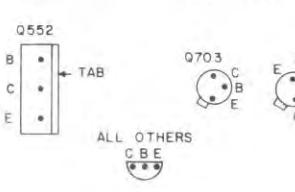

- METER 3
- METER 2
- METER 1
- CONTROL VOLTAGE
- PL-TONE-DPL CODE
- XMIT SW 9.3V
- GND
- EXCITER AUDIO HI
- EXCITER AUDIO LO
- GND
- 9.4V DC
- GND
- KEYED A-
- NOT USED
- F1 SELECT
- F2 SELECT
- F3 SELECT
- F4 SELECT
- GND

NOTE:
 1. COMPONENTS DESIGNATED WITH ASTERISK (*) ARE PRESENT ON DUPLEX MODELS (TLD9242A, 41A) ONLY.
 2. COMPONENTS AND JUMPERS DESIGNATED WITH SQUARE (■) ARE PRESENT ON SIMPLEX MODELS (TLD9232A, 31A) ONLY.

EXCITER

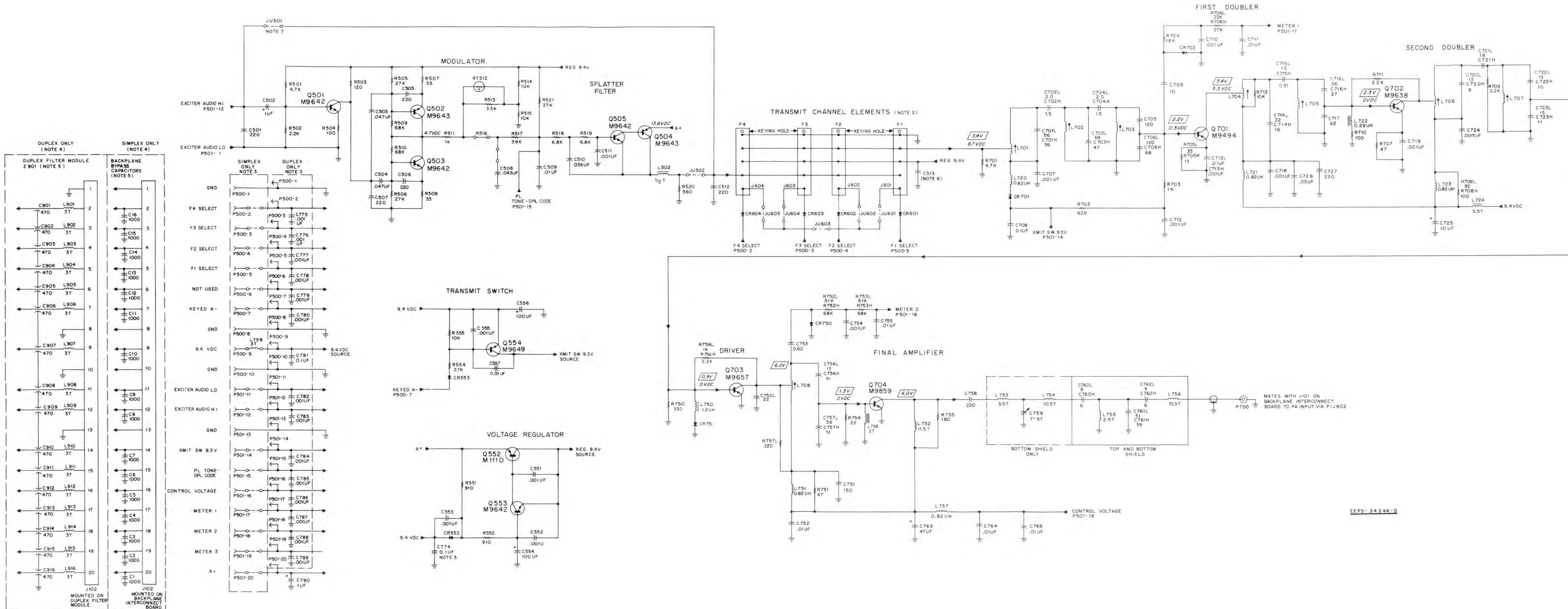

Exciter Range			
Kit No.	Range	Frequency (MHz)	Type
TLD9231A	Low (L)	132-150.8	Simplex
TLD9232B	High (H)	146-174	Simplex
TLD9241B	Low (L)	132-150.8	Duplex
TLD9242C	High (H)	146-174	Duplex

- NOTES:
- Unless otherwise indicated, resistor values are in ohms and capacitor values are in picofarads.
 - Transmitter frequency calculation:
Foscillator = Fchannel/2
 - TLD9231A/TLD9232B Simplex Exciter uses jumpers shown, with female edge connectors P500/P501. TLD9241/TLD9242 Duplex Exciter uses C775-C789 shown, with male edge connectors P500/P501.
 - Simplex exciter is connected to male backplane connector J102. Duplex exciter is connected to female filter module connector J102.
 - Backplane bypass capacitors C1-C16 and duplex filter module are part of backplane interconnect board assembly. Refer to associated Control and Applications manual for replacement parts information and location.
 - Refer to parts list for component values.
 - JU501 always out on standard models.

TLD9231A and TLD9232B Simplex Exciter and
TLD9241B and TLD9242C Duplex Exciter
Schematic Diagram
Motorola No. PEPS-34789-D
(Sheet 3 of 3)
9/13/84 - V & G

EXCITER



POWER AMPLIFIER INTERMITTENT DUTY

MODEL TLD2532A

1. GENERAL

The TLD2532A Power Amplifier consists of the power amplifier chassis and associated hardware, and contains two circuit boards, the power control board and the power amplifier board. The following sections detail the theory of operation and troubleshooting information for the power amplifier circuitry. Because the setting of power levels is affected by the alignment of the exciter, the power set procedure is part of the overall transmitter alignment procedure given in the Transmitter section of this manual.

Table 1. Power Amplifier Kits

TLD2532A Power Amplifier
TFD6452A Harmonic Filter
TKN8313A Power Amplifier Cable
TLD9252A Power Amplifier Board
TLD9272A Power Control Board
TRN5141A Power Amplifier Hardware Kit
TRN5378A PA Transistor and Hardware Kit

2. THEORY OF OPERATION

2.1 POWER AMPLIFIER BOARD

2.1.1 The output from the exciter is applied to the power amplifier board via J802. This 1.5 watt (nominal) signal is attenuated approximately 2.8 dB by the resistive network comprised of R807-R810. Pre-driver Q801 amplifies the exciter signal to a level of approximately 11 watts.

2.1.2 The predriver output is applied to driver Q802, which develops up to 25 watts of rf power. The final amplifier stage of Q803/Q804 provides the power output of 110 watts (nominal). The power output signal is routed through the harmonic filter and through the directional coupler to the station antenna circuitry.

2.2 POWER CONTROL CIRCUITRY

2.2.1 General

2.2.1.1 The power control board provides power amplifier protection and power regulation. Output impedance match, final amplifier current and

temperature, control voltage level, and power output are monitored by the power control circuit. In turn, the power control circuit sets the exciter power output to the proper level for optimum power amplifier operation.

2.2.1.2 The resistive voltage divider comprised of R926, R927, and R928 provides dc biasing voltages to improve directivity of the directional coupler, and set the operating point of the directional coupler inputs to the forward power and protection comparators. The reference voltage for forward power detector U901A is developed across Power Set control R911. The reference voltage for protection comparator U901B is developed at the junction of R914 and R913.

2.2.2 Thermal Protection

As the temperature of the power amplifier board increases, the resistance of RT801 decreases, causing the voltage on the TEMP SENSE HI line to decrease. When this voltage reaches approximately 5 volts, CR904 conducts, dropping both the forward power detector and protection comparator reference voltages. This causes the comparators to reduce the voltage on the CONTROL VOLTAGE line, which reduces exciter drive to the power amplifier. The net effect of this is to lower power amplifier output and heat, keeping operating temperature within safe operating limits.

2.2.3 Forward Power Level Control

Forward output power, sampled by the directional coupler, is rectified and filtered by the circuitry associated with CR901. The detected voltage is applied to the inverting input of forward power detector U901A, where it is compared to the set level at the non-inverting input. If the two levels are not the same, the output level of U901A changes in a direction that raises or lowers the voltage on the CONTROL VOLTAGE line, until the inputs to U901A are matched. This provides a constant rf power output from the PA.

POWER AMPLIFIER - INTERMITTENT DUTY

2.2.4 Reverse Power Protection

Reverse (reflected) power sampled by the directional coupler is rectified and filtered by the circuitry associated with CR902. The output voltage across R908 is applied to the inverting input of U901B, and compared to the reference voltage. Under normal operating conditions with the transmitter feeding a 50-ohm load, the reference voltage is higher than the directional coupler voltage. This keeps the output of U901B at maximum, keeping Q905 turned off. If the reflected power increases to the point that the voltage across R908 exceeds the reference voltage, the output of U901B drops, turning on Q905. Increased collector voltage on Q905 causes an increase in the voltage applied to the inverting input of U901A, to force the control voltage and the power output to drop until the inputs to U901A equalize.

2.2.5 Over-Current Protection

Final amplifier current in the power amplifier is sensed through R801. The voltage drop across R801 is applied to the base at Q907. As the voltage at Q907 decreases, Q907 turns on, increasing the voltage across R908. The power cutback occurs in the same manner as described in the Reverse Power Protection paragraph.

2.2.6 Control Voltage Limit

The circuit of Q905 compares the voltage on the CONTROL VOLTAGE line to the voltage set by the position of the wiper on R931. When the control voltage exceeds the set limit, Q905 conducts, raising the voltage at the inverting input of U901A. U901A, in turn, reduces the control voltage until both inputs are balanced.

3. POWER AMPLIFIER SERVICING

3.1 GENERAL

Troubleshooting information for the MSR 2000 station power amplifier is presented in several levels. It is best to begin by following the power amplifier troubleshooting procedure given in Table 4. If the specific cause of the transmitter failure is not covered in Table 4, the service person is directed to Table 5 (for power control board problems) or to paragraph 3.2 (for power amplifier board problems).

3.2 POWER AMPLIFIER BOARD TROUBLESHOOTING PROCEDURE

Checks and tests in the following paragraphs may be used to locate defects isolated to the power amplifier board. The following checks assume 13.8 volts dc is applied to the PA and that the amplifier is operating closed-loop with the exciter. Set all power control potentiometers (R911, R931, R939) fully clockwise.

3.2.1 No Power Output or Power Output Less Than 20% of Rated Power

3.2.1.1 Voltage Checks

With the radio unkeyed and the receiver audio at a minimum, check for +13.3 V dc on the power amplifier collectors. If one or more stages has zero voltage, check associated dc feed circuits for an open circuit.

3.2.1.2 Individual Stage Current Checks

Check the collector currents drawn by all stages to determine if the normal value shown in Table 2 is drawn.

Table 2. Minimum Normal Current Reading (all power control potentiometers set fully clockwise)

	I _c	146-155 MHz	155-165 MHz	165-174 MHz
Q801	Direct	1.7A	1.2A	0.75A
Q802	Direct	3.0A	2.4A	2.1A
	Drop across R822	300 mV	240 mV	210 mV
Q803-4	Direct	20A	17A	18A
	Drop across R801	20 mV	170 mV	180 mV
	MTR 5	20 uA	17 uA	18 uA

Step 1. If a stage is found with less than minimum I_c (see Table 2), check for shorts or defective components in that stage, then in the preceding and following stages.

Step 2. Where more than one stage indicates low current, check the earliest defective stage (toward the PA input) first.

Step 3. If all stages give a low current indication, check the exciter output. The exciter is defective if the output is less than 1.5 W.

3.2.2 Power Output Does Not Exceed the Rated Radio Power by 20% at Maximum Power Settings

3.2.2.1 Check A+ and A- voltages at the collectors with the power amplifier operating. Use *only* a passive voltmeter or a VOM with 1.2 uH series chokes at the probe tips. With the power supply accurately set for 13.8 V dc, voltages on the transistor collectors should exceed the Table 3 values (all voltages measured with respect to the A- plating on the power amplifier board).

Step 1. If all voltages are low, recheck the power supply. If the power supply is satisfactory, check the feed-through capacitors for poor solder connections and the A+ and A- connections for good contact.

Step 2. If only one or two stages have low voltages, trace back through the dc-feeds of that stage, checking

for bad connections or defective components. The maximum normal voltage drops are 0.3 V dc for R801, 0.5 V dc for R822, and less than 0.1 V dc for all other components in the dc feed circuits.

Table 3. PA Collector Voltages
(@13.8 V A + /A - Supply)

Q801	13.0 V dc
Q802	12.6 V dc
Q803, 804	12.8 V dc

3.2.2.2 Check the stage currents as outlined in paragraph 3.2.1.2.

3.2.2.3 If trouble in the final amplifier transistor stage (Q803, 804) is indicated, or other approaches have failed, check the balance in the final amplifier by soldering a 2.7 V lamp (type 338, Motorola Part No. 65-82671G01) between the collectors of Q803 and Q804 using #14 wire or a 0.1 inch wide copper strap or braid. If the lamp lights up to greater than half its normal brilliance, or flashes and burns out, there is a defect in one side of the parallel final amplifier circuitry. If such imbalance is indicated, the defective section can usually be isolated by shorting the base to emitter of one transistor (at the transistor body) with a screwdriver blade. The section that shows the least drop in power output (when shorted) is the one to be checked for defective components. If no obviously defective passive components, misconnections, or shorts can be located, make the following tests prior to considering the replacement of Q803 or Q804.

NOTE

Remove all power from the PA for the following tests.

Step 1. Check in-circuit base-emitter resistance on the suspect transistor(s). If *greater* than 1 ohm, coil L809 or L810 is bad.

NOTE

Place the negative potential lead from the ohmmeter on the transistor base for this test.

Step 2. If the resistance check shows that L809 and L810 are not defective, remove the base capacitors, C825 and C827 (for Q803) or C826 and C828 (for Q804), and check for shorts, both internal (with an ohmmeter), and external (visual check for solder shorts on the capacitor or printed circuit board). If a capacitor or its connection is suspect, replace it and recheck the power output and balance before proceeding.

Step 3. If the capacitor is not defective, replace transistor (Q803 or Q804) and reassemble the power amplifier.

NOTE

In any case where gross imbalance is found and suspected faulty components are replaced, *always* recheck balance after replacing components. Continue the investigation if imbalance has not been fully corrected.

3.2.2.4 With all power removed from the radio set, check for open base return on Q801 and Q802 by measuring in-circuit base-emitter resistance. The resistance should be less than 1 ohm on Q801 and less than 2.5 ohms on Q802.

NOTE

Place negative potential lead of ohmmeter on transistor base(s) for this test.

3.3 POWER AMPLIFIER TRANSISTOR REPLACEMENT

3.3.1 To remove the power transistors, remove two transistor mounting screws, or one stud nut (accessible from the chassis bottom). Unsolder and remove the clamped mica capacitors, unsolder and remove the transistors. (Special soldering iron tips ST1160 and ST1161 are available from the Motorola National Parts Department to aid in the capacitor and transistor removal.)

3.3.2 When replacing rf power transistors several precautions *must* be observed. First remove all thermal compound and residue from *both the chassis and the transistor* using a soft cloth or paper towel. Apply a thin film of silicone thermal compound to the bottom of the transistor mounting flange. Place the transistor in the center of the printed circuit board cutout and tighten the mounting hardware to 6-7 inch pounds *maximum*. Solder leads using a low power (40-60 W) iron using enough solder to completely cover the lead and solder pad. *Make sure* that the solder is flowing freely both *over* and *under* the lead before removing the heat. If a lead tends to spring away from the printed circuit board, hold down the far end of the lead against the board (using the tip of pliers) until the solder hardens. *Be sure* to replace the clamped mica capacitors in the *exact* original position with respect to the transistor body after replacing the transistors.

3.3.3 When removing components from the power amplifier printed circuit board it is *essential* that the solder be *completely molten* around the lead(s) to be removed *before* attempting to remove any component(s). Failure to exercise this precaution *could result* in removal of through-plating in component holes and/or top side metal on the printed circuit board which may necessitate removal of the printed circuit board for repair. To ensure proper performance of the rf power amplifier, it is *essential* (when replacing board-mounted parts) that the parts be mounted vertically and with the bottom of the component(s) flush against the printed circuit board.

3.4 POWER AMPLIFIER BOARD REMOVAL

3.4.1 Under normal maintenance conditions, there should be no need to remove the PA board. If, however, it should become necessary, the following procedure should be used. Unsolder and remove the input and output coaxial cables, unsolder feedthrough

capacitors, remove hex head screws, transistor mounting screws, and stud nut(s) (accessible from the bottom). Lift the board out of the chassis.

3.4.2 To replace the PA board, reverse the removal procedure. PA power transistors should be installed after the circuit board installation has been completed. Refer to paragraph 3.3.

Table 4. Power Amplifier Troubleshooting Procedure

Step	Symptom	Procedure	Normal Indication	If Normal	If Abnormal
1	Suspected Transmitter Failure	Measure rf output power at antenna connector.	Rated power	Transmitter OK	High Power — perform Power Amplifier Control and Protection Troubleshooting Procedure. Low Power — go to 3. No Power — go to 2.
2	No Output Power	a. Set all controls fully clockwise and observe meters 1 and 5.	Both greater than 10 uA	Go to b.	No indication — Perform Transmitter Control and Protection Troubleshooting Procedure. Meter 1 indication, no Meter 5 indication — Go to e.
		b. Measure dc voltage across antenna relay coil during transmit.	5 V	Go to c.	Check coil continuity (dc resistance approximately 160 ohms).
		c. Check reed switch continuity.	Continuous during transmit	Go to d.	Replace.
		d. Check harmonic filter and output cable for shorts and discontinuities.	See schematic diagram	Perform Power Amplifier Board Troubleshooting Procedure.	Repair defect.
		e. Measure rf power at the exciter output.	1.5 W minimum	Perform Power Amplifier Board Troubleshooting Procedure.	Refer to Exciter section of manual.
3	Low Output Power	a. Set all controls fully clockwise and observe Meter 1.	Greater than 20 uA	Go to b.	Perform Power Amplifier Control and Protection Troubleshooting Procedure.
		b. Measure rf power at exciter output.	1.5 W minimum	Perform Power Amplifier Board Troubleshooting Procedure.	Refer to Exciter section of manual.

Table 5. Power Amplifier Control and Protection Troubleshooting Procedure

Step	Symptom	Procedure	Normal Indication	If Normal	If Abnormal
1	No meter 1 or 5 with all controls clockwise	a. Disconnect PA from exciter J802. Check for keyed 9.3 V at U901-8.	9.3 V	Go to b.	Check Q554 (in exciter) keyed 9.3 V switch.
		b. Measure output voltage of U901A, pin 1.	Greater than 3.3 V	Repair fault in control voltage amplifiers Q903 & Q904.	Go to c.
		c. Measure voltages to input of U901A, pins 2 & 3.	Pin 3 greater than Pin 2	U901 defective.	Check for shorts or opens in resistive feed circuits to pins 2 & 3.
2	Meter 1 reads max of about 10 uA with all controls fully clockwise. Little or no output power	a. Disconnect PA from exciter at J802. Measure voltage of protection comparator output, at U901B-7.	Greater than 7 V	Troubleshoot Q905 circuit.	Go to b.
		b. Measure voltages to input of U901B, pins 5 & 6.	Pin 5 greater than Pin 6	U901 defective.	Analyze and repair current limiter circuitry Q906, Q907 & Q908.
3	All controls inoperative and meter 1 approx. 25 uA	a. Disconnect PA from exciter at J802. Observe meter 1 in RX mode.	0 uA	Go to b.	Repair fault in control voltage amplifiers Q903 & Q904.
		b. Set all controls counter-clockwise. Measure pins 2 & 3, U901A in TX mode.	Pin 2 greater than Pin 3	U901 defective	Look for defect in voltage reference network R926, U927, R928, R912, R911.
4	Control voltage limit (R931), current limit (R939) and reflected power (VSWR) protection inoperative	Q905 and associated resistors probably defective. Analyze and repair.			
5	Current limit (R939) inoperative	Disconnect PA from exciter at J802. Pull current sense line (green) from C897. Observe meter 1.	15 uA	Check for short to A+ of current sense line.	Analyze fault in current limit circuit Q906, Q907 & Q908 and repair.
6	Reflected power (VSWR) protection inoperative	Check and repair defect in reflected power detector components R902, CR902, etc.			
7	Thermal protection inoperative	Check and repair defect in thermal protection components RT801, R915, R930 and CR904.			
8	Power set (R911) inoperative	Check and repair defect in forward power detector components R901, CR901, etc.			

3.5 POWER AMPLIFIER FUNCTIONAL TESTS

S1056-59 Portable Test Set, into J1 on power control board.

3.5.1 General

The tests in this section should be performed *after* servicing but *before* alignment, to verify that the power amplifier and control circuitry are operating correctly.

CAUTION
Key transmitter only while making test or adjustment.

3.5.2 Set-up

Step 1. Connect radio to proper dummy load through a wattmeter.

Step 2. Plug metering connector of DC Metering Chassis, TEK 5 Metering Panel (set to position E) or

3.5.3 Control and Protection Tests

3.5.3.1 Control Voltage Limiting

Step 1. Set Current Limit (R939) and Power Set (R911) fully clockwise.

POWER AMPLIFIER

Step 2. Set Control Voltage Limit (R931) fully counterclockwise. Key transmitter and observe meter 1. Meter 1 should read approximately 4 uA.

Step 3. Rotate Control Voltage Limit Set (R931) clockwise. Near mid-rotation the reading of M1 should begin increasing to a maximum of approximately 25 uA at maximum clockwise rotation.

3.5.3.2 Current Limiting

Step 1. Set Power Set (R911) and Control Voltage Limit (R931) fully clockwise.

Step 2. Set Current Limit (R939) fully counterclockwise. Key transmitter and observe M5. Meter 5 should indicate less than 8 uA. Rotate Current Limit clockwise. Meter 5 should increase to a maximum indication of no more than 28 uA before maximum clockwise rotation is reached.

3.5.3.3 Power Set

Step 1. Set Control Voltage Limit (R931) and Current Limit (R939) fully clockwise.

Step 2. Set Power Set (R911) fully counterclockwise.

Step 3. Key transmitter and observe wattmeter. Power output should be zero. Power output should increase as Power Set is rotated clockwise.

3.5.3.4 Thermal Protection

Step 1. Set Control Voltage Limit (R931) and Current Limit (R934) fully clockwise.

Step 2. Adjust Power Set (R911) to 120 watts output. Using a short length, (6 inches) of 22 AWG solid wire, short Temp Sense Hi, pin 6 of P901, to Temp Sense Lo, pin 7 of P901, with P901 connected to J901 on the power control board. Power output should drop to less than 50% of set power.

3.5.3.5 Reflected Power Protection

Step 1. Set Control Voltage Limit (R931) and Current Limit (R939) fully clockwise.

Step 2. Adjust Power Set (R911) for 120 watts output. Remove cable from the output of the station.

CAUTION

As the following step requires transmitting without a dummy load, key transmitter long enough to verify operation only.

Step 3. Key transmitter and observe meter 5. Meter 5 should indicate less than 10 uA.

3.5.4 Power Amplifier Board Test

Step 1. Disconnect PA from antenna switch/duplexer at J803.

Step 2. Connect the PA directly to a wattmeter and dummy load via J803.

Step 3. Set Power Set (R911), Control Voltage Limit (R931), and Current Limit (R939) fully clockwise.

Step 4. Key transmitter and observe the wattmeter. Power output should exceed 145 watts.

POWER CONTROL BOARD

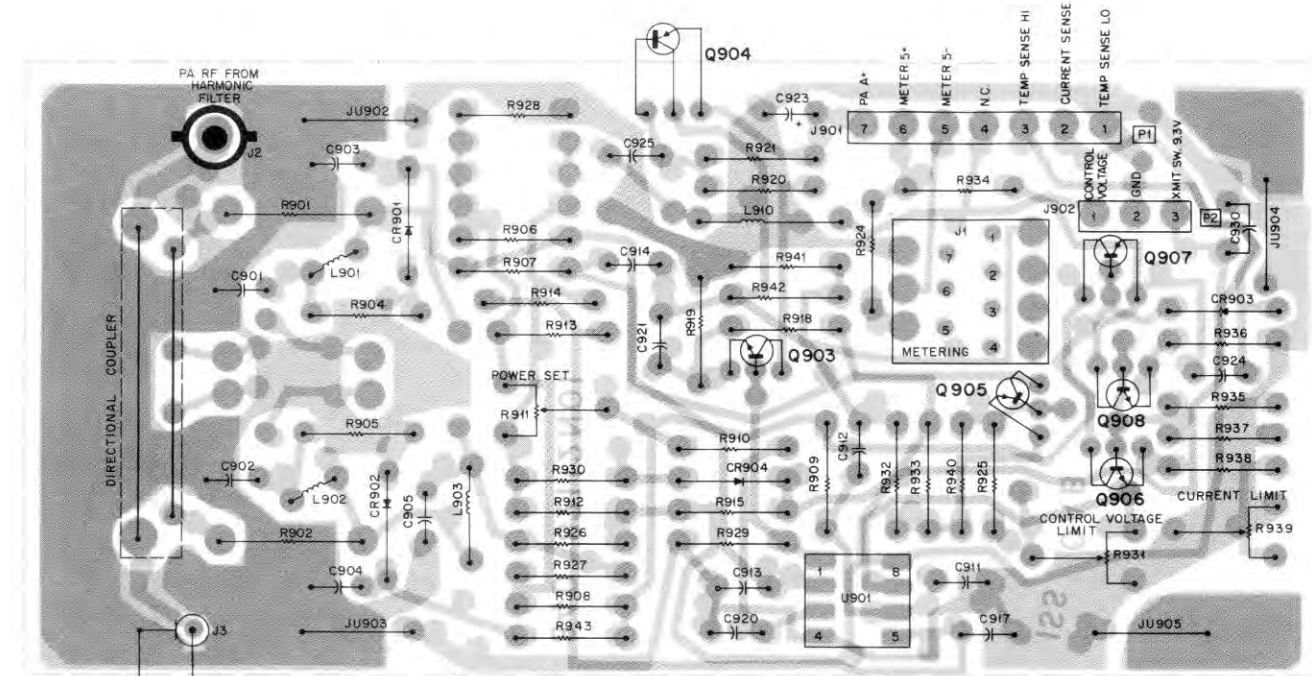

SHOWN FROM COMPONENT SIDE

COMPONENT SIDE: BD DEPS-34661-0
 SOLDER SIDE: BD DEPS-34662-0
 OL DEPS-34663-A

TRANSISTOR BASE DETAILS (SHOWN FROM COMPONENT SIDE)
 CBE
 ALL EXCEPT Q904
 B C E
 Q904

POWER CONTROL BOARD

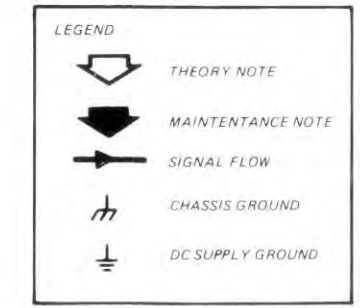
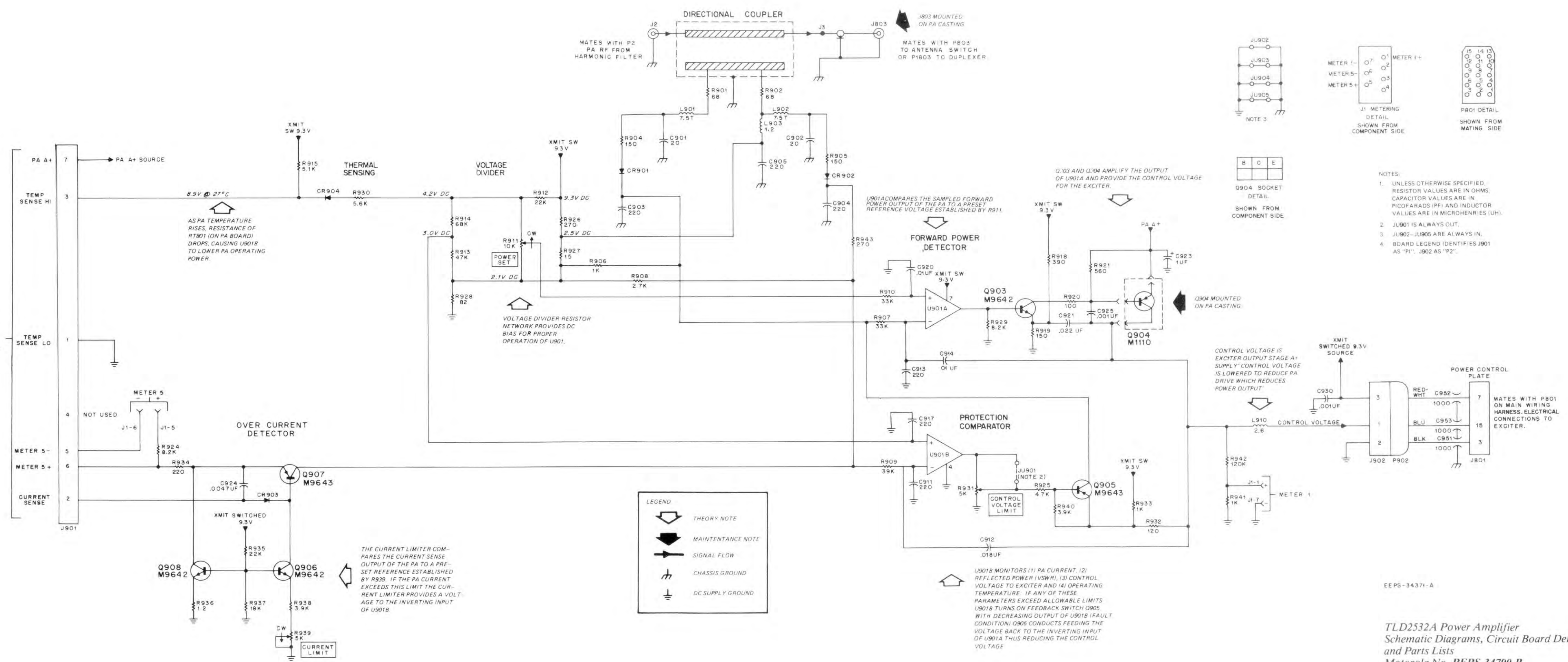

U901B MONITORS (1) PA CURRENT, (2) REFLECTED POWER (VSWR), (3) CONTROL VOLTAGE TO EXCITER AND (4) OPERATING TEMPERATURE. IF ANY OF THESE PARAMETERS EXCEED ALLOWABLE LIMITS U901B TURNS ON FEEDBACK SWITCH Q905 WITH DECREASING OUTPUT OF U901B (FAULT CONDITION) Q905 CONDUCTS FEEDING THE VOLTAGE BACK TO THE INVERTING INPUT OF U901A THUS REDUCING THE CONTROL VOLTAGE.

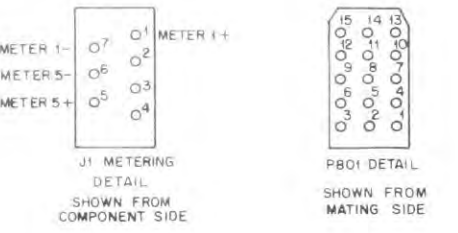
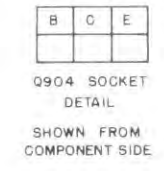

- NOTES:
- UNLESS OTHERWISE SPECIFIED, RESISTOR VALUES ARE IN OHMS, CAPACITOR VALUES ARE IN PICOFARADS (PF) AND INDUCTOR VALUES ARE IN MICROHENRIES (UH).
 - JU901 IS ALWAYS OUT.
 - JU902-JU905 ARE ALWAYS IN.
 - BOARD LEGEND IDENTIFIES J901 AS "P1", J902 AS "P2".

EEPS-34371-A

TLD2532A Power Amplifier
 Schematic Diagrams, Circuit Board Details,
 and Parts Lists
 Motorola No. PEPS-34790-B
 (Sheet 1 of 3)
 1/14/83- V&G

POWER AMPLIFIER

POWER AMPLIFIER BOARD

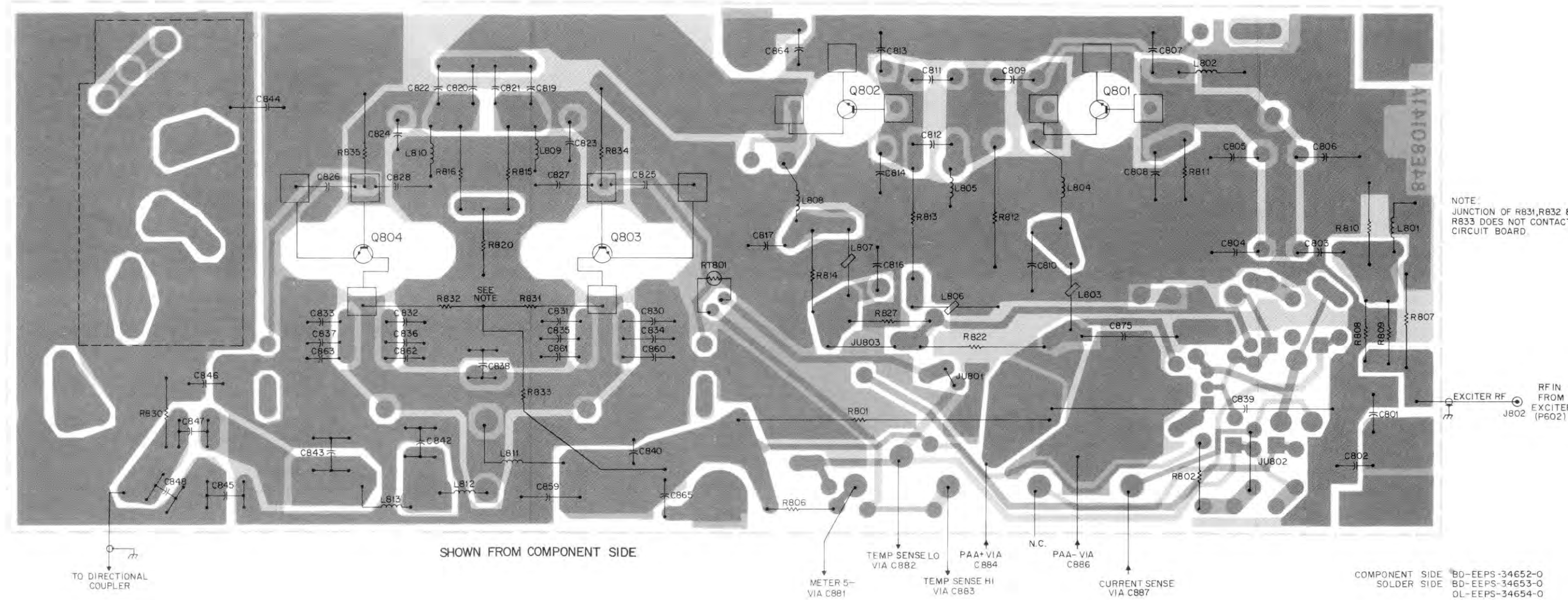

parts list

TLD9252A Power Amplifier Board PL-7938-A

REFERENCE SYMBOL	MOTOROLA PART NO.	DESCRIPTION
C801	21-863629	capacitor, fixed: pF ± 5%; 500 V; unless otherwise stated
C802	21-82372C10	.05 uF ± 20%; 25 V
C803	21-83406D77	30
C804	21-84493B59	39
C805, 806	21-83406D77	30
C807, 808	21-84493B65	100
C809	21-84493B66	150
C810	21-83596E10	220 ± 20%
C811, 812	21-84715F26	56
C813, 814	21-84493B64	91
C816	8-84637L14	0.1 uF ± 10%; 100 V
C817	21-83596E10	220 ± 20%
C819	21-83406D56	24
C820, 821	21-84493B35	19
C822	21-83406D56	24
C823, 824	21-84715F26	56
C830 thru 837	21-84715F26	56
C838	21-83366K16	150
C839	23-83210A22	660 uF ± 150-10%; 25 V
C840	21-863629	330 ± 10%; 600 V
C842	21-84395B18	44; 250 V
C843	21-84395B16	15 ± 10%; 250 V
C844	21-84493B59	39
C845	21-84395B35	240 ± 10%; 350 V
C846	21-863629	330 ± 10%; 600 V
C847	21-84395B35	240 ± 10%; 350 V
C848	21-84395B45	12 ± 10%; 250 V
C859	8-83293B02	0.22 uF ± 10%; 50 V
C860 thru 863	21-83406D97	15
C864	21-82187B07	470 ± 10%
C865	21-83596E10	220 ± 20%
C875	8-82905G02	0.22 uF ± 10%; 50 V
L801	24-83884G01	3-1/2 turns; coded (PINK)
L802	24-82723H27	choke; 1.2 uH
L803	24-80036A02	choke; 1/2 turn
L804	24-80277A01	12-1/2 turns
L805	7-80062B02	bracket, large 1/2 turn
L806, 807	24-80036A02	choke; 1/2 turn
L808	24-80277A05	1-1/2 turns
L809, 810	24-82723H27	choke; 1.2 uH
L811	24-80277A04	7-1/2 turns
L812, 813	7-80062B04	bracket, small; 1/2 turn
R801	17-80165C01	resistor, fixed: ± 5%; 1/2 W; unless otherwise stated
R802	6-11009C49	.01 ± 20%; bracket type
R806	6-11009C33	1k; 1/4 W
R807	6-125A37	330
R808, 809	6-11009C13	33; 1/4 W
R810	6-125A37	330
R811	6-125C01	10 ± 10%
R812	6-127C17	47 ± 10%; 2 W
R813	17-82036G07	1.5 ± 10%; 2 W
R814	6-125B81	4.7
R815, 816	6-125A09	22
R820	6-125A15	39
R822	17-82291B24	0.1 ± 5%; 3 W
R830	6-11009C37	100k; 1/4 W
R834, 835	6-125A21	66
RT801	6-83600K09	thermistor; 100k @ 25°C
mechanical parts		
29-80014A01		CLIP, coax terminal

TFD6452A PA Harmonic Filter PL-7935-0

REFERENCE SYMBOL	MOTOROLA PART NO.	DESCRIPTION
C1	21-83366K33	capacitor, fixed; 15 pF ± 5%; 850 V
C3, 5	21-82785H52	30 pF ± 1 pF; 850 V
C7	21-83366K33	15 pF ± 5%; 850 V
coil, rf:		
L2	24-80066A04	5-1/2 turns
L4	24-80066A03	6-1/2 turns
L6	24-80066A04	5-1/2 turns
connector, plug:		
P2	28-82231G01	male; single contact
mechanical parts		
1-80748D72		ASSEMBLY, cable input includes:
29-5370		LUG, solder
30-83794C01		CABLE, coaxial (WHT); 8" used
1-80748D73		ASSEMBLY, cable output includes:
5-136977		EYELET
30-83794C01		CABLE, coaxial (WHT); 8-1/2 used
7-83373N01		FRAME

TLD9272A Power Control Board PL-7940-0

REFERENCE SYMBOL	MOTOROLA PART NO.	DESCRIPTION
C901	21-11022G37	capacitor, fixed: pF ± 10%; 50 V; unless otherwise stated
C902	21-11022G37	20 ± 5%
C903, 904, 905	21-11015B05	220
C911	21-11015B05	220
C912	8-11017B10	.018 uF
C913	21-11015B05	220
C914	8-11017B08	.01 uF
C917	21-11015B05	220
C920	21-11021F04	.01 uF
C921	8-11017B11	.022 uF
C923	23-11019A09	1 uF ± 20%; 50 V
C924	21-11021E21	4700
C925	21-11015B13	.001 uF ± 10%; 100 V
C930	21-11015B13	.001 uF ± 10%; 100 V
diode: (see note)		
CR901, 902	48-84616A01	hot carrier silicon
CR903, 904	48-83654H01	silicon
connector, receptacle:		
J1	9-84207B01	female; 7-contact (metering)
J2	9-84231B03	female; phone
J3	42-80259A01	clip, coax terminal
connector, plug:		
J901	28-83441F08	male; 7-contact (WHT)
J902	28-83441F18	male; 3-contact (WHT)
jumper:		
JU902 thru 905	6-11009B23	0 ohms
L901, 902	24-84393B04	coil, rf; 7-1/2 turns
L903	24-82723H01	choke; 1.2 uH
L910	24-82835G08	choke; 2.6 uH
transistor: (see note)		
Q903	48-869642	PNP; type M9642
Q905	48-869643	PNP; type M9643
Q906	48-869642	PNP; type M9642
Q907	48-869643	PNP; type M9643
Q908	48-869642	PNP; type M9642
resistor, fixed ± 5%; 1/4 W; unless otherwise stated		
R901, 902	6-125A21	66 ± 5%; 1/2 W
R904, 905	6-11009A29	150
R906	6-11009A49	1k
R907	6-11009A85	33k
R908	6-11009A59	2.7k
R909	6-11009A87	39k
R910	6-11009A85	33k
R911	18-80268B03	variable; 10k
R912	6-11009A81	22k
R913	6-11009A89	4.7k
R914	6-11009A93	68k
R915	6-11009A66	5.1k
R918	6-11009A39	390
R919	6-11009A29	150
R920	6-11009A25	100
R921	6-11009A43	560
R924	6-11009A71	8.2k
R925	6-11009A65	4.7k
R926	6-11009A35	270
R927	6-11009A05	15
R928	6-11009A23	82
R929	6-11009A71	8.2k
R930	6-11009A67	5.6k
R931	18-80268B02	variable; 5k
R932	6-11009A27	120
R933	6-11009A49	1k
R934	6-11009A33	220
R935	6-11009A81	22k
R936	6-11009A51	1.2k
R937	6-11009A79	18k
R938	6-11009A63	3.9k
R939	18-80268B02	variable; 5k
R940	6-11009A63	3.9k
R941	6-11009A49	1k
R942	6-11009A99	120k
R943	6-11009A35	270
integrated circuit: (see note)		
U901	51-80067C03	dual operational amplifier
mechanical parts		
14-80278B01		INSULATOR, coupler; 2 used
26-80279B01		SHIELD, coupler
9-80028A01		SOCKET, transistor (Q901)
30-80280B01		THROUGH LOOP, coupler
30-80280B02		PICK-UP LOOP, coupler

note: For optimum performance, diodes, transistors, and integrated circuits must be ordered by Motorola part numbers.

TRN5378A PA Transistor and Hardware Kit PL-7937-A

REFERENCE SYMBOL	MOTOROLA PART NO.	DESCRIPTION
C825 thru 828	21-84366F12	capacitor, fixed; 200 pF ± 5%; 250 V
transistor: (see note)		
Q801	48-84411L90	PNP; type M1190
Q802	48-84411L91	PNP; type M1191
Q803, 804	48-84411L04	PNP; type M1104
Q904	48-84411L10	PNP; type M1110
resistor, fixed:		
R831, 832	6-126C01	10 ± 10%; 1 W
R833	6-127C05	15 ± 10%; 2 W
mechanical parts		
2-7003		NUT, 8-32 x 5/16"; 2 used
3-3375		SCREW, tapping; 6-20 x 5/16"; 9 used
3-3396		SCREW, tapping; 6-20 x 3/8"
3-129841		SCREW, machine; 4-40 x 1/4"
3-134186		SCREW, tapping; 6-32 x 5/16"; 4 used
3-138813		SCREW, machine; 4-40 x 3/8"; 4 used
3-488006		SCREW, machine; 6-32 x 1/2"; 4 used
4-859060		WASHER, insulator; 4 used
4-84180C01		WASHER, shoulder; 1 used
14-84391F01		INSULATOR, transistor
15-80066B01		COVER, harmonic filter
15-82400N01		COVER, PA
26-83374N04		SHIELD, harmonic filter
5-129977		EYELET

note: For optimum performance, diodes, transistors, and integrated circuits must be ordered by Motorola part numbers.

TRN5141A Power Amplifier Hardware PL-7939-A

REFERENCE SYMBOL	MOTOROLA PART NO.	DESCRIPTION
C870, 871	21-84211B01	capacitor, fixed; .01 uF; GMV; 250 V (feed-thru)
connector, receptacle:		
J802	9-82442E01	RECEPTACLE, PA rf in
strip, terminal:		
TB801	31-50378	barrier type; 2 terminal
mechanical parts		
2-131435		NUT, 4-40 x 1/4 x 3/32"; 2 used
3-3375		SCREW, tapping; 6-20 x 5/16"; 4 used
3-115213		SCREW, machine; 3-48 x 1/4"; 4 used
3-129890		SCREW, machine; 10-32 x 3/8"; 6 used
3-131195		SCREW, machine; 6-32 x 3/8"; 3 used
3-138294		SCREW, tapping; 8-32 x 5/8"; 2 used
3-138810		SCREW, machine; 4-40 x 5/8"; 2 used
4-7681		LOCKWASHER, #3 internal; 4 used
14-80143A04		INSULATOR, HB, LB
14-82406N01		INSULATOR, control
14-82407N01		INSULATOR
26-82323N01		HEAT SINK, PA
29-5347		LUG, soldering; 2 used
29-129863		LUG, soldering
30-83794C01		CABLE, coaxial (WHT); 4" used
43-82275C01		SPACER
43-82416N01		SPACER, feed-thru
64-82986N01		PANEL, PA

TKN8313A Internal Cable Kit PL-8318-0

REFERENCE SYMBOL	MOTOROLA PART NO.	DESCRIPTION
C881 thru 887	21-82812H03	capacitor, fixed; 1000 pF ± 100-0%; 500 V (feed-thru)
C891 thru 897	21-821474	470 pF ± 20%; 500 V (feed-thru)
C951, 952, 953	21-82812H03	1000 pF ± 100-0%; 500 V (feed-thru)
connector, feed-through:		
J801	1-80748D81	ASSEMBLY, POWER control plate; includes: C951, 952, 953
	64-82405N01	PLATE, plug
connector, receptacle:		
J803	9-82442E01	RECEPTACLE, PA rf out
P901	15-83498F15	HOUSING, 7-contact
P902	15-83498F28	HOUSING, 3-contact
mechanical parts		
1-80748D80		ASSEMBLY, control cable; includes: P902
29-83499F01		TERMINAL; 3 used
42-10217A02		STRAP, tie; 2 used
1-80748D82		ASSEMBLY, power control feed-thru; includes:
30-8378K01		CABLE, 7-conductor shield; 12" used
1-80748D83		ASSEMBLY, PA feed-thru plate; includes: C881 thru 887
64-80005A01		PLATE, feed-thru
1-80748D92		ASSEMBLY, cable power out; includes: J803;
15-483599		HOOD, receptacle
30-83794C01		CABLE, coaxial WHT; 4-1/2"
1-80748D84		ASSEMBLY, cable interface; includes: P901
29-83499F01		TERMINAL; 6 used
30-8378K01		CABLE, 2-conductor shielded; 9-1/2"
1-80753D16		ASSEMBLY, interface plate; includes: C891 thru 897
64-82404N01		PLATE, RF

TLD2532A Power Amplifier Schematic Diagrams, Circuit Board Details, and Parts Lists Motorola No. PEPS-34790-B (Sheet 2 of 3) 1/14/83- V&G

POWER AMPLIFIER BOARD

TLD9252A POWER AMPLIFIER BOARD
 TRN5141A PA HARDWARE
 TRN5378A PA TRANSISTOR AND HARDWARE KIT

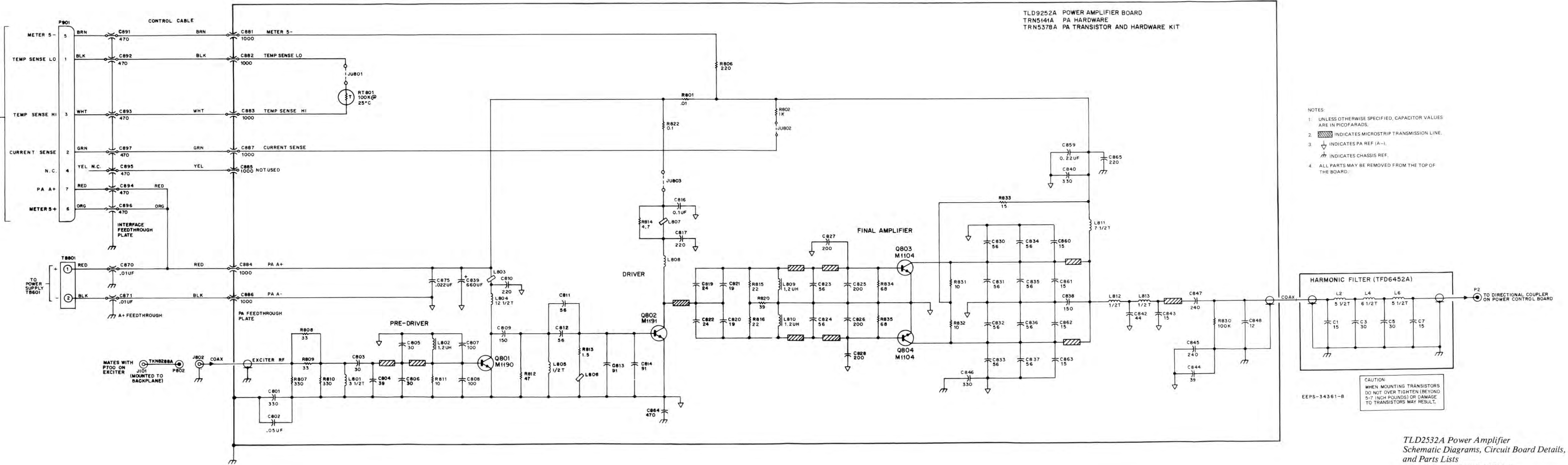

- NOTES:
1. UNLESS OTHERWISE SPECIFIED, CAPACITOR VALUES ARE IN PICOFARADS.
 2. [Hatched box symbol] INDICATES MICROSTRIP TRANSMISSION LINE.
 3. [Triangle symbol] INDICATES PA REF (A-).
 4. [Ground symbol] INDICATES CHASSIS REF.
 5. ALL PARTS MAY BE REMOVED FROM THE TOP OF THE BOARD.

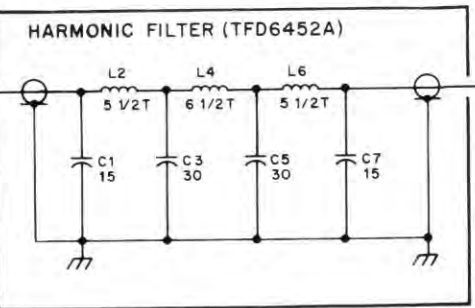

CAUTION
 WHEN MOUNTING TRANSISTORS
 DO NOT OVERTIGHTEN (BEYOND
 5-7 INCH POUNDS) OR DAMAGE
 TO TRANSISTORS MAY RESULT.

EEPS-34361-B

TLD2532A Power Amplifier
 Schematic Diagrams, Circuit Board Details,
 and Parts Lists
 Motorola No. PEPS-34790-B
 (Sheet 3 of 3)
 1/14/83-V&G

POWER AMPLIFIER



1. GENERAL

The TLD2600A Series Power Amplifier (refer to Table 1) consists of the power amplifier chassis and associated hardware, and contains three circuit boards: the power control board, the power amplifier board, and the exciter control voltage regulator board. The following sections detail the theory of operation and maintenance information for the power amplifier circuitry. Because the setting of the power levels is affected by the alignment of the exciter, the power set procedure is a part of the overall transmitter alignment procedure given in the Transmitter section of this manual.

Table 1. Power Amplifier Frequency Range

Model	Frequency Range (MHz)
TLD2601A	132-150.8
TLD2602A	150.8-162
TLD2603A	162-174

2. THEORY OF OPERATION

2.1 POWER AMPLIFIER BOARD

(Refer to Figure 1 and schematic diagram)

2.1.1 This series of power amplifiers requires a 400 mW rf input from the exciter board. This input is passed through a ferrite step-down transformer (to match the input impedance to the first stage) to the gain-controlled amplifier stage. The external power control circuit which drives the control stage transistor determines the gain of this stage. The power control circuit monitors the output of the final stages of the power amplifier and the load condition.

2.1.2 The output of the gain-controlled amplifier is passed through a fixed-tuned broadband matching network and applied to the pre-driver stage. A second ferrite transformer is utilized to match the single-ended output of the pre-driver stage to the input of the push-pull driver stage. The output of the driver stage is split by a pair of transformers to drive each of the push-pull final power amplifier stages. The output from each final stage is stepped up in impedance by ferrite

transformers and paralleled to provide the 50 ohm output impedance to match the input impedance of the harmonic filter.

2.1.3 Pin 1 of the metering receptacle provides a means of checking the incoming signal from the exciter. Pin 2 permits observation of the drive output of the first stage and an indication of the operation of the pre-driver stage. Pins 3 and 4 reflect the output drive signal and operation of the two push-pull power amplifier stages. Reference position A on a Motorola Portable Test Set uses pin 7 of the metering socket as an A + reference against which the outputs of pins 1, 2, 3, and 4 are checked. Switch the test set to reference position B which uses pin 6 as a reference and then switch to meter position 5. This provides a reading across a calibrated resistor through which the current is drawn by the final amplifier stages.

2.2 POWER CONTROL BOARD FUNCTIONAL THEORY OF OPERATION

2.2.1 Refer to the loop block diagram, Figure 2. The circuitry operates as a control loop which continually monitors the output from the final stages of the transmitter power amplifier and controls that output by regulating the gain of the first stage of the power amplifier.

2.2.2 Refer to the block diagram, Figure 3. The output of the integrated circuit differential amplifier, amplified by the dc amplifier, is the controlling input to the power amplifier board.

2.2.3 The output of the differential amplifier is determined by the potentials present on the non-inverting (+) and inverting (-) inputs. These potentials are developed by the power control board circuitry in the following manner.

2.2.4 When the impedances of the antenna circuitry (load) and the power amplifier are matched (a VSWR of 1:1), a bias voltage produced by the dc reference bias circuitry is placed on the inverting input (also called the "reference input") of the differential amplifier (see Figure 6).

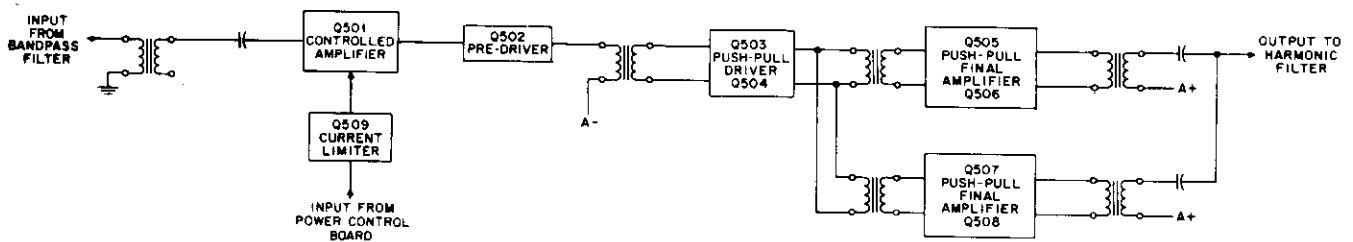

69D81008E43-A

Figure 1. Block Diagram

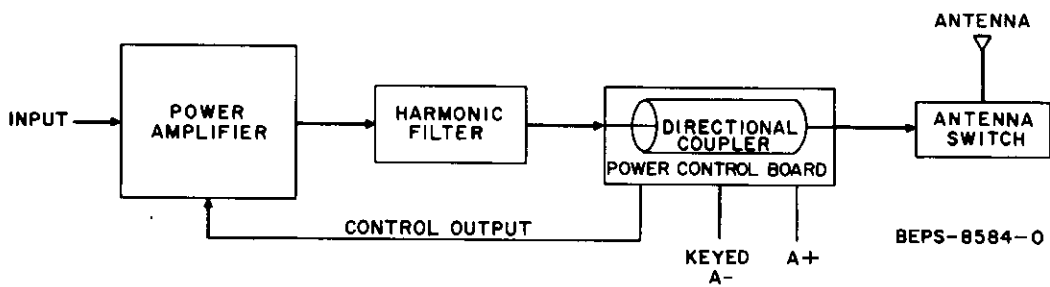

BEPS-8584-0

Figure 2. Loop Block Diagram

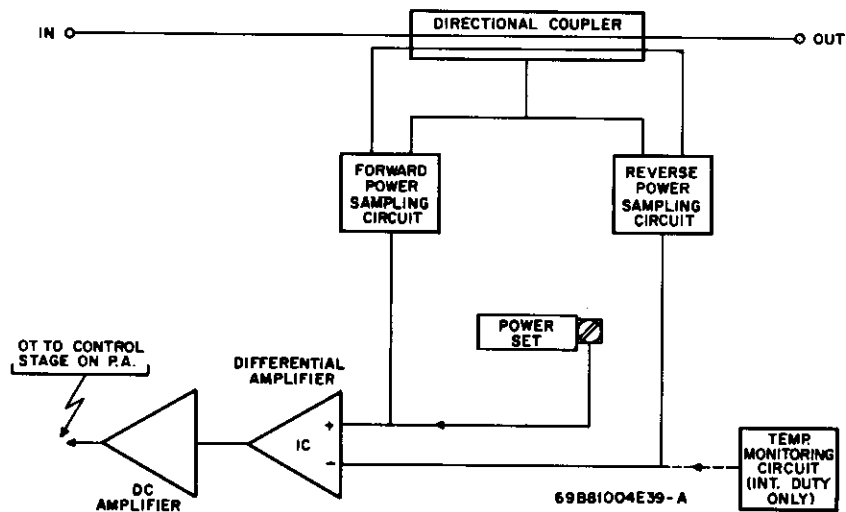

69B81004E39-A

Figure 3. Power Control Board Block Diagram

2.2.5 When the transmitter is keyed, the forward (output) power from the final stages of the power amplifier is fed through the directional coupler to the antenna circuit. This flow of power is sampled by the forward power sampling circuitry and places a bias, proportional to the forward power, on the non-inverting input (pin 5) of the differential amplifier. The POWER SET potentiometer is then adjusted, changing the potential on the non-inverting input. As this voltage changes, relative to the reference input voltage, the output of the differential amplifier changes, in turn changing the loop control level and therefore the output of the power amplifier.

2.2.6 Once the power has been set to the proper level, any change in the output power will be instantly corrected by the circuitry. If the power increases, the increase causes the differential amplifier output voltage to increase, decreasing the output from the dc amplifier which decreases the gain of the power amplifier until the output returns to the preset level. A decrease in transmitter power amplifier output causes the reverse action.

2.2.7 Any power reflected back from the antenna circuit is detected by the reverse power sampling circuit. Reverse power causes a negative current to flow, which, in turn, decreases the potential on the reference input of the differential amplifier. Therefore, increasing levels of reflected power will cause the transmitter power output to be decreased to a safe level.

2.3 POWER CONTROL BOARD DETAILED THEORY OF OPERATION

2.3.1 Bias Circuitry

Since the power control board has the capability to regulate the output of the transmitter power amplifier from a completely cut-off state to above the rated output power, a definite controlled output level is necessary whenever the transmitter is keyed. The desired controlled output level is determined by bias voltages present on the inverting and non-inverting inputs of the differential amplifier IC601 (see Figure 4). Under normal operating conditions (1:1 VSWR; 100% rated power out) the bias on the differential amplifier inputs are developed as described in the following paragraphs.

2.3.1.1 Voltage Regulator and Main Divider Line

Refer to Figure 5. The A + supply to the board is regulated by a series regulator circuit providing a nominal voltage of 8.0 volts. The Zener diode holds the base of the series pass transistor at a fixed potential. The series pass transistor operates as a variable resistor to hold the input to the reference circuitry constant. The divider consisting of the two resistors and the diode provides the proper voltage tap points for the secondary voltage divider networks. All 220 pF capacitors in the board are used as rf bypasses.

2.3.1.2 Reference Bias Circuit

Refer to Figure 6. The reference bias is developed (with a 1:1 VSWR) by the voltage divider made up of two resistors and a diode between the regulated supply voltage and the switched A - source. Since A + is applied to the board continuously and A - is only applied when the transmitter is keyed by the push-to-talk switch, the larger capacitor connected between the inverting input and keyed A - provides a time constant which allows the inverting input bias to build up slowly when power is first applied. This prevents full power output from occurring until the leveling circuitry can react and reach a quiescent level.

2.3.2 Directional Coupler

The directional coupler measures the voltage and the current traveling in both directions. The detection of forward (output) power causes a proportional voltage bias that is combined with the voltage-divider generated bias to set the potential on the non-inverting input of the differential amplifier. Any reverse power detected causes the VSWR circuitry to decrease the power output.

2.3.3 Protection Circuitry

2.3.3.1 Forward Power Bias and Detection Circuit

Refer to Figure 7. The forward power reference voltage divider comprised of two resistors and two potentiometers provides a stable potential that supplies a dc bias to the non-inverting input of the differential amplifier. With an approximately correct power output from the final stages of the power amplifier, a dc level proportional to that power is produced by the forward power detector circuit, which, in combination with the voltage developed by the voltage divider, produces a bias on the non-inverting input that can be adjusted by the POWER SET potentiometer. The POWER LIMIT control is pre-set to prevent over-dissipation if the POWER SET control should be set to maximum. (Refer to the CAUTION preceding maintenance information in this section.) The dc bias value will be determined by the power amplifier output and, with no reflected power (VSWR 1:1), balanced against the reference bias present on the inverting input of the differential amplifier. Once the bias has been set, and change in power output will change the bias on the non-inverting input causing the differential amplifier to compensate for the deviation. The forward power detector circuit (refer to Figure 8) detects rf power flowing through the directional coupler when the transmitter is keyed, and causes a small proportional current flow in the forward power sampling circuit. The diode converts the rf sample into a pulsating dc voltage and the dc filter removes the ripple. This is the dc voltage which is added to the dc bias already applied to the non-inverting input of the differential amplifier from the secondary divider circuitry.

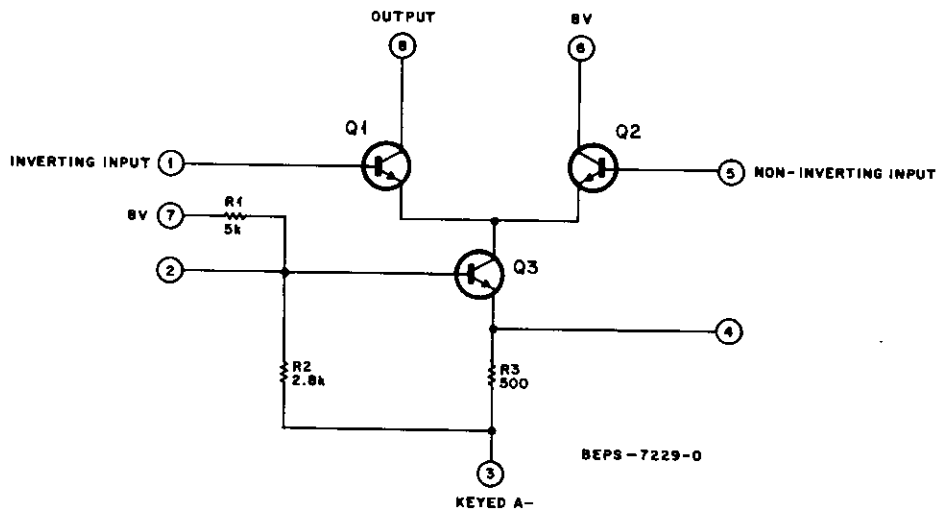

Figure 4. IC601 Schematic Diagram

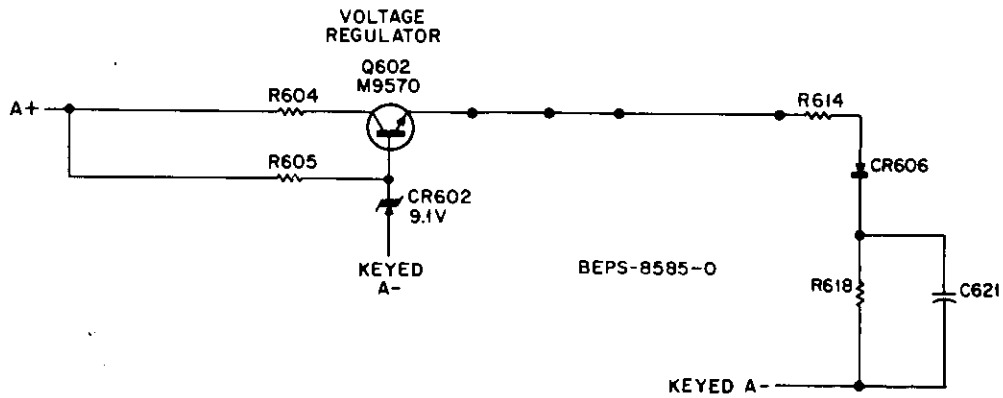

Figure 5. Voltage Regulator and Main Divider Line

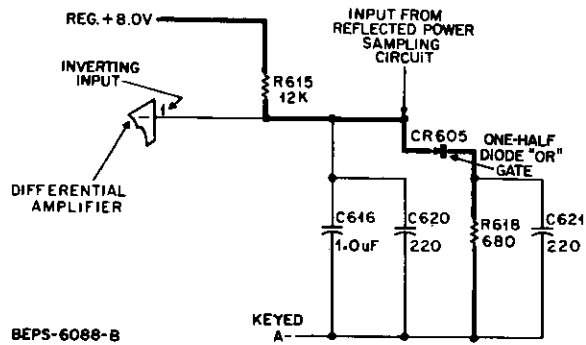

Figure 6. Reference Power Bias Circuit

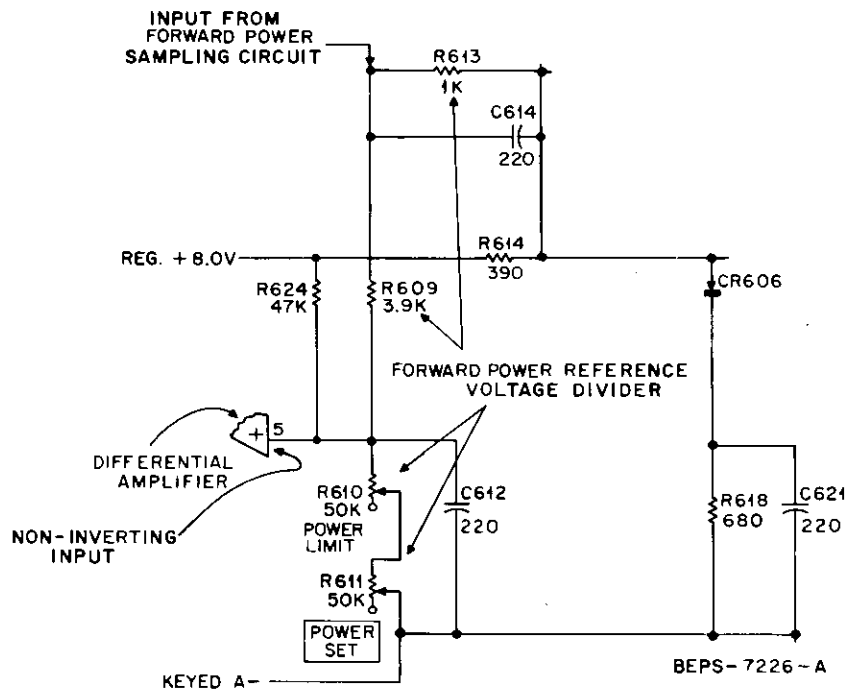

Figure 7. Forward Power Bias Circuit

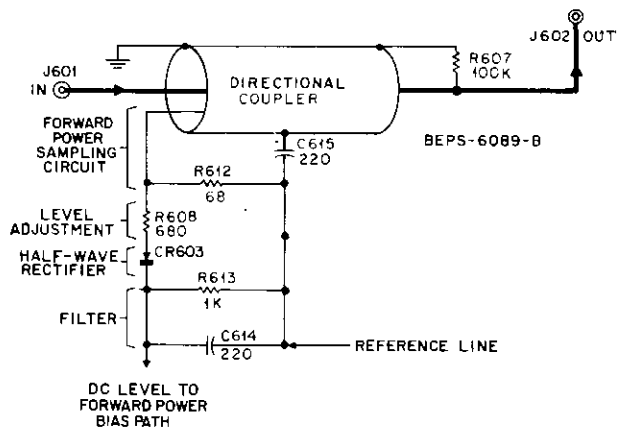

Figure 8. Forward Power Detector Circuit

2.3.3.2 VSWR — Reverse Power Detection Circuit

Since the power control board is now operating correctly with the proper amount of forward power and the correct biases, the detection of reflected power causes a decrease in the power amplifier's output in the following manner.

Refer to Figure 9. The components of the reverse power detector circuit function the same as those in the forward power detector. The voltage divider develops a bias voltage that isn't quite enough to forward bias the diode that makes up one-half of a diode "OR" gate. When reflected power is detected, the resultant negative-going dc level lowers the dc bias level

and the combination of the two forward bias the diode. The negative-going dc level on the inverting input increases the output voltage of the differential amplifier, decreasing the dc control output to protect the final stages of the power amplifier.

2.3.3.3 DC Level Output Amplification

The output of the differential amplifier is applied to the base of a voltage-inverting transistor amplifier whose output supplies the output control current. As the forward power increases above the normal value, the output of the differential amplifier increases proportionally. Since the dc level is increasing the base, the PNP transistor conducts less and the potentials across the output load resistor, and on the control output line, decrease.

3. MAINTENANCE

3.1 POWER AMPLIFIER BOARD

3.1.1 General

NOTE

Because of the complexity involved and time required to remove the PA board, compared to plug-in boards, it is not recommended that the PA board be removed. Proper troubleshooting techniques will usually locate defective components "on the spot."

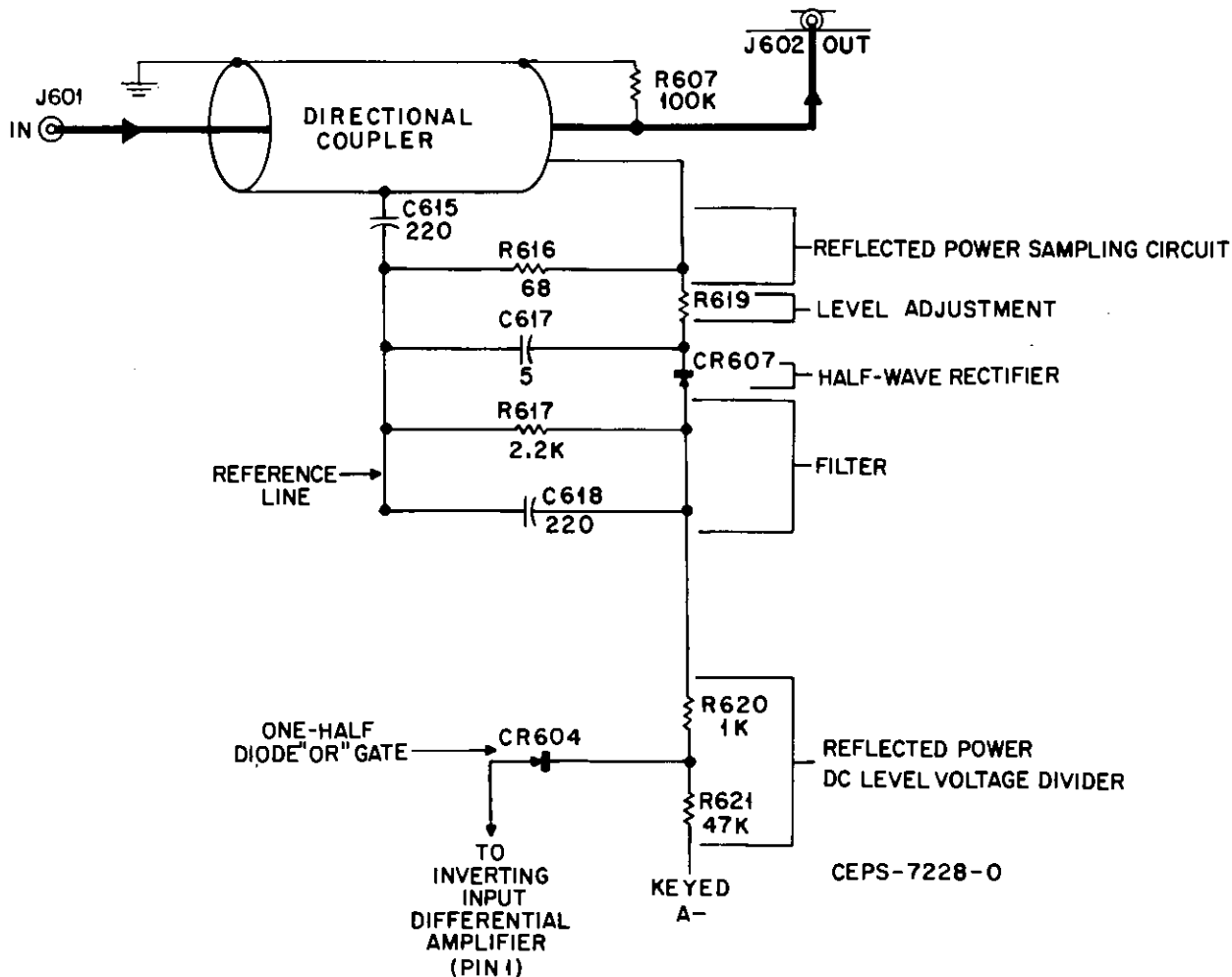

Figure 9. Reverse Power Detector Circuit

This section of the manual provides the maintenance shop procedures for the PA board. It assumes that preliminary tests have already localized the trouble to the PA board. These procedures include measurements with a Motorola portable test set, a VOM, a complete set of performance tests, and extensive troubleshooting procedures.

CAUTION

The PA board must be installed in the transmitter for testing to provide the necessary power, ground, control, heat sinking and signal connections.

3.1.2 Recommended Test Equipment

The following test equipment is the minimum required for troubleshooting and adjusting the PA.

- Motorola S1056B through S1059B Portable Test Set and Model TEK-37 or TEK-37A Adapter Cable. The portable test set is required for checking each stage for proper operation.
- A Motorola Solid-State DC Multimeter or a 20,000 ohm-per-volt multimeter should be used, however a low impedance multimeter is acceptable for dc voltage measurements only.
- Motorola T1013A RF Load Resistor (dummy load) or equivalent.

3.1.3 Test Set Metering

The PA is equipped with a metering receptacle which allows five major test points to be measured. PA metering can be made at each of the five test points by merely rotating a selector switch on the optional station

meter kit or on the test set. A failure in almost any portion of the PA will produce a low or zero meter reading for one or more of the test points. Improper alignment will also cause improper meter readings.

NOTE

A dummy load is preferred to the antenna to eliminate the possibility of shutback by the power control board due to a defective antenna.

3.1.4 Using the Portable Test Set

3.1.4.1 To make the measurements, the portable test set must be connected to the station as follows.

Step 1. Set the function selector switch of the portable test set to the XMTR position.

Step 2. Set the meter reversing switch of the test set to the METER REV position, the selector switch to position 1, and REF switch to position A.

Step 3. Connect the 20-pin meter cable plug to the test set. When the test set is not in use, disconnect the 20-pin plug to conserve battery life. The plug acts as an on-off switch completing the battery circuit.

Step 4. Connect the red "control" plug of the adapter cable to the control receptacle on the remote control board. Connect the white "metering" plug of the adapter cable to the receptacle on the PA circuit board.

Step 5. The entire transmitter is necessary for testing PA boards including the power control board for proper control.

Step 6. The output of the station must be terminated in one of three types of loads:

- (1) The antenna load.
- (2) A dummy load such as Motorola's T1013A RF Load Resistor.
- (3) An RF wattmeter.

Step 7. Turn the station ON.

Step 8. Key the transmitter with the XMTR ON button on the test set. Observe the meter. Unkey the transmitter.

Step 9. Set the selector switch to positions 2, 3, & 4; then switch to reference position B and meter position 5 respectively, keying the transmitter and observing the meter reading for each. Refer to Table 2. On multi-frequency stations, repeat the readings for each frequency. An analysis of the meter readings for determining whether each circuit is good or bad follows.

3.1.4.2 Each time maintenance is performed on the PA the readings should be compared with the previous set of readings. Any degradation of performance will quickly be noted. Often, a lower reading may indicate an impending failure and corrective action may be taken before the circuit fails entirely.

3.1.5 Performance Tests

Step 1. No performance test of the power amplifier is required other than rf power output from the station as a whole. Before checking power output:

- (1) The exciter board should be known to be operating normally.
- (2) The power control board should be known to be functioning normally.

Step 2. Key the transmitter and observe power out, which should be 100 watts or value set from 50 to 100 watts depending upon licensing.

Table 2. Power Amplifier Board Metering

Selector Switch Position	Reference Switch Position Portable Test Set Only	Minimum Meter Readings	Circuit Metered	If Low, Defective Circuit Is: (See Troubleshooting Charts)
1	A	10 uA	Exciter Output (input to Controlled Amplifier Q501)	Exciter output, input circuitry of controlled amplifier stage Q501.
2	A	5 uA	Input of Pre-driver Stage (Q502)	Output of controlled amplifier stage input circuitry of predriver stage.
3	A	10 uA	Input of Final Amplifier Stage Q505, Q506	Input of Q505, Q506 stages, output of driver stage (Q502, Q503), output of pre-driver stage Q502.
4	A	10 uA	Input of Final Amplifier Stage Q507, Q508	Input of Q507, Q508 stage output of driver stage Q502, Q503. Output of pre-driver stage Q502.
5 (or 2)	B	29 uA max. 105 W	Total Current in Final Amplifier Stages Q505, Q506, Q507, Q508	Output of final amplifier stages Q505-Q508, power control board antenna switch, antenna.
6 (or 3)	B	12 V (0-30 V scale)	Final Amplifier Stage	Final amplifier stage A + or A - input.

3.2 POWER CONTROL BOARD

CAUTION

The power control board is incorporated in the transmitter to provide protection for the rf power transistors under environmental conditions such as voltage, load variation, and device variations. In order for the circuitry to operate properly and provide protection it is necessary to set the power output control (POWER SET) in accordance with the station alignment procedure.

3.2.1 General

3.2.1.1 Two basic maintenance approaches may be used for localizing and replacing trouble in these radio sets.

- Replace the defective circuit board with a spare and return the defective board to a maintenance shop for repair.
- Isolate and repair the trouble on the spot. This approach must be used if spares are not available.

3.2.1.2 Regardless of the maintenance approach used, a few simple tests on the overall radio set will localize the trouble to the power control board if it is defective. These procedures are given elsewhere in the manual. This section of the manual provides the maintenance shop level procedures for the power control circuitry. It assumes that preliminary tests have already localized the trouble to the power control board. These bench test type procedures include measurements with a Motorola portable test set, a simple set of performance tests, and complete troubleshooting procedures including step-by-step circuit check-out.

3.2.2 Recommended Test Equipment

The following test equipment is the minimum required for troubleshooting and adjusting the board. All such equipment is battery operated. When ac operated equipment is used, the ground lead must not be electrically connected to ac line ground.

- Optional station metering or Motorola S1056B through S1059B Portable Test Set and Model TEK-37 or TEK-37A Adapter Cable. (The meter or portable test set is necessary to monitor forward and reverse power detectors.)
- Motorola Solid-State DC Multimeter or equivalent. A 20,000 ohm-per-volt multimeter may be used but a low impedance volt-ohm meter may not be used. This meter is used for measuring dc voltages and resistance.

- Motorola T1013A RF Load Resistor (Dummy Load) or equivalent.

3.2.3 Metering

The power control board is equipped with a metering receptacle which allows three major test points (forward power, reflected power and control current) to be measured. Refer to the troubleshooting charts or the schematic diagram for the correct meter indications.

3.2.4 Using Portable Test Set

Step 1. Set the function selector switch of the portable test set to the XMTR position.

Step 2. Set the meter reversing switch of the test set to the METER REV position.

Step 3. Set the REF switch to position A or B.

Step 4. Connect the 20-pin meter cable plug to the test set. When the test set is not in use, disconnect the 20-pin plug to conserve battery life. The plug acts as an on-off switch completing the battery circuit.

Step 5. Connect the red "control" plug of the adapter cable to the control receptacle on the remote control circuit board. Connect the white "metering" plug of the adapter cable to the receptacle on the power control board.

Step 6. The output of the power control board must be terminated in one of three types of loads.

- (1) The antenna load.
- (2) A dummy load such as Motorola's T1013A RF Load Resistor.
- (3) An RF wattmeter.

NOTE

A dummy load is preferred to the antenna to eliminate the possibility of shutback due to a defective antenna.

Step 7. Turn the station ON.

Step 8. Set the selector switch of the test set to position 1 and key the transmitter with the XMTR ON button on the test set. Observe the wattmeter, or the eter reading if a dummy load is used or if the antenna is used. Unkey the transmitter. Under normal conditions at rated power out, meter 1 should read between 15 uA and 45 uA typically. Refer to Table 3.

3.2.5 Performance Test, Power Set Control

This control allows the power output of the radio set to be varied from zero (0) power out with the control fully counterclockwise to greater than the rated output.

Table 3. Power Control Board Metering

Selector Switch Position	Reference Switch Position (See Note)	Normal Meter Readings	Function
1	A (Meter Reverse On)	15-45 uA	Indicates forward power output.
2	A	10 uA max.	A meter reading higher than the normal range indicates reflected power caused by a defective antenna, antenna switch, or cables.
5	B (Meter Reverse On)	50 uA max.	Indicates the relative level of drive sent to the PA on the blue control lead. A reading of greater than 35 uA indicates the power control board is set for a higher power than the radio is capable of supplying.

METERING NOTE

Alignment may be performed using a Motorola S1056B thru S1059B Portable Test Set. The OSC. & METER REV. SWITCH column refers to portable test set usage.

CAUTION

For proper operation of the protection circuitry, it is imperative that the POWER SET control never be left in a position that exceeds rated power output.

Refer to the power amplifier tune-up procedure.

Step 1. Key the transmitter.

Step 2. Adjust the POWER SET control until the rated power output is reached.

Step 3. Unkey the transmitter.

4. TROUBLESHOOTING PROCEDURES

4.1 GENERAL

If a problem has been localized to either the power amplifier or power control board decks, several checks can be made prior to extensive troubleshooting.

4.2 VISUAL

Visually check for obvious physical defects such as broken leads, broken plating, broken or disconnected components or overheated parts. Before any attempt is made to change parts, the circuit should be checked to insure that the problem causing the original failure has been identified and corrected, otherwise damage to the new part may occur.

4.3 VOLTAGE CHECKS

Check for A+ and A- at the feedthrough connections and for proper voltages at the collectors of each transistor. Certain defects such as broken plating, broken leads etc. may not be obvious to a visual inspection.

4.4 TROUBLESHOOTING

4.4.1 If test set readings are abnormal or tests indicate subnormal performance, a logical troubleshooting procedure is required to isolate the defective

component efficiently. The accompanying troubleshooting chart summarizes these results in a logical sequence. A few voltage and resistance checks in the suspected circuit should readily isolate the defective component. Note that all power for the circuits in the PA and power control board is from A - referenced to A + (not to chassis ground, this feature allows operation from positive or negative ground power sources when an optional positive ground converter is used).

CAUTION

Due to the voltage requirements of PNP transistors, all "rf ground" plating is A + and is "hot" with respect to chassis ground in negative ground applications. Because of this, caution should be used to prevent connection of "ground" plating on the PA board to chassis ground, either directly or by the use of test equipment ground leads. If ac operated test equipment is used, the ground lead must not be electrically connected to ac line ground.

4.4.2 The schematic diagrams of the PA board and power control board contain the voltage readings required for troubleshooting. The readings are typical for normal operating conditions at rated power output for the radio. Refer to the troubleshooting charts and the schematics when a defect is suspected.

5. REPAIR PROCEDURES

5.1 RESISTANCE MEASUREMENT OF TRANSISTORS IN PUSH-PULL PAIRS

Due to the fact that transistors in push-pull pairs are dc connected at both base and emitter, BOTH devices should be measured when a defect in the pair is suspected.

5.2 TRANSISTOR REMOVAL PROCEDURE

Step 1. Unscrew both mounting screws from the base of the transistors. The nuts (for the mounting screws) on the reverse side of the shelf are captivated and will not fall out.

Step 2. Remove excess solder from around transistor tabs with a vacuum bulb type de-soldering device.

Step 3. Gently lift each lead, one at a time while applying heat.

Step 4. When all four leads are loose from the board carefully lift out the transistor.

5.3 TRANSISTOR INSTALLATION PROCEDURE

Step 1. Pre-tin underside of each transistor lead.

Step 2. Apply a light coat of Wakefield Thermal Compound to the underside of the transistor mounting base and to the heat sink.

Step 3. Install the transistor making sure that all collector leads face the proper direction. Refer to the circuit board detail.

Step 4. Screw down the two mounting screws securely.

Step 5. Solder each transistor lead one at a time to the circuit board. The use of a generous amount of solder will insure a good contact of the entire tab to the board. Use care that solder does not bridge to other plating or that solder does not flow into the cutout in the circuit board.

5.4 PROCEDURES FOR RESISTANCE MEASUREMENTS OF TRANSISTORS

Step 1. Set ohmmeter to RX1, RX10 or RX100 scale (preferably RX10 if available).

Step 2. Measure the resistance from lead to lead as described in (a) thru (c). Should any indication be observed in measurements (a) or (c), the transistor is defective and should be replaced.

(a) With the positive probe on the base, no indication (very high impedance) should be observed when the negative probe is touched to the collector or emitter. (Reverse drop measurement.)

(b) With the negative probe on the base, a relatively low impedance should be observed when touching the positive probe to the collector and emitter. (Forward drop measurement.)

(c) No indication should be observed from collector to emitter regardless of the polarity of the ohmmeter probes.

POWER CONTROL BOARD TROUBLESHOOTING CHART

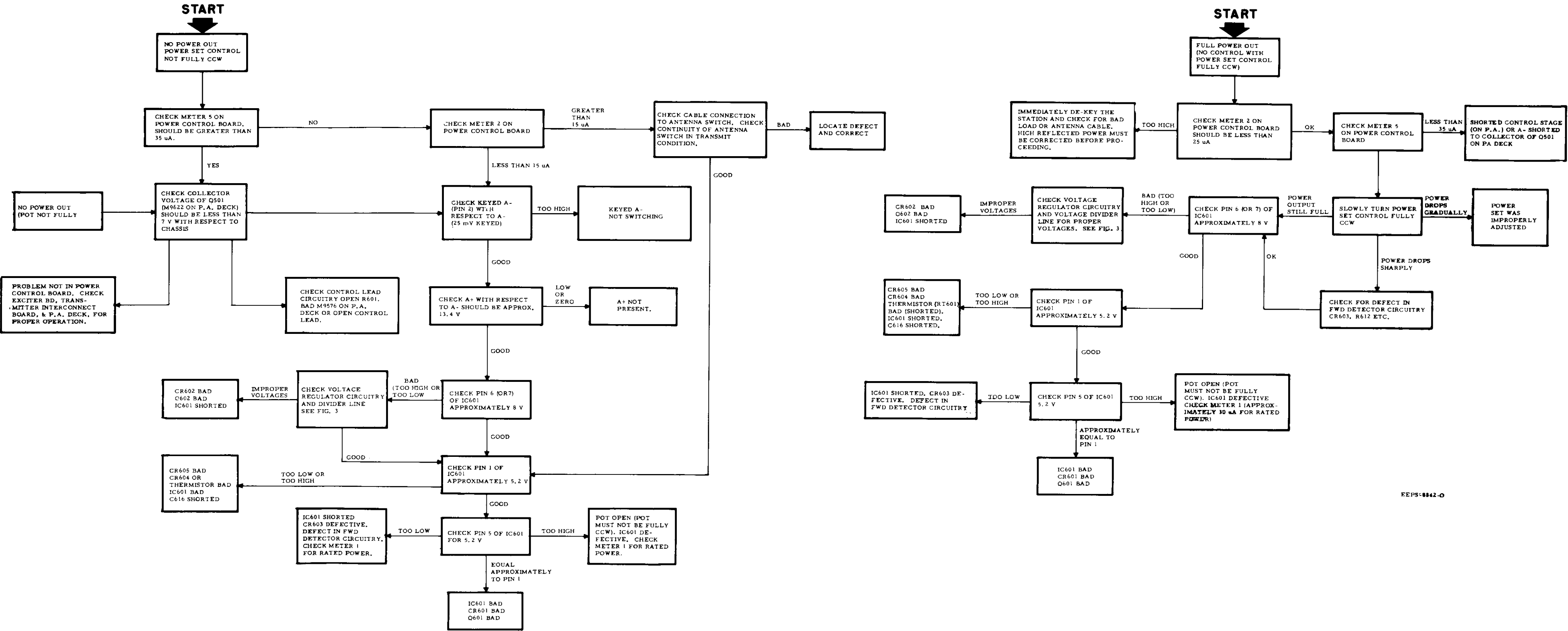

EEPS-8842-0

POWER AMPLIFIER - CONTINUOUS DUTY

POWER AMPLIFIER TROUBLESHOOTING CHART

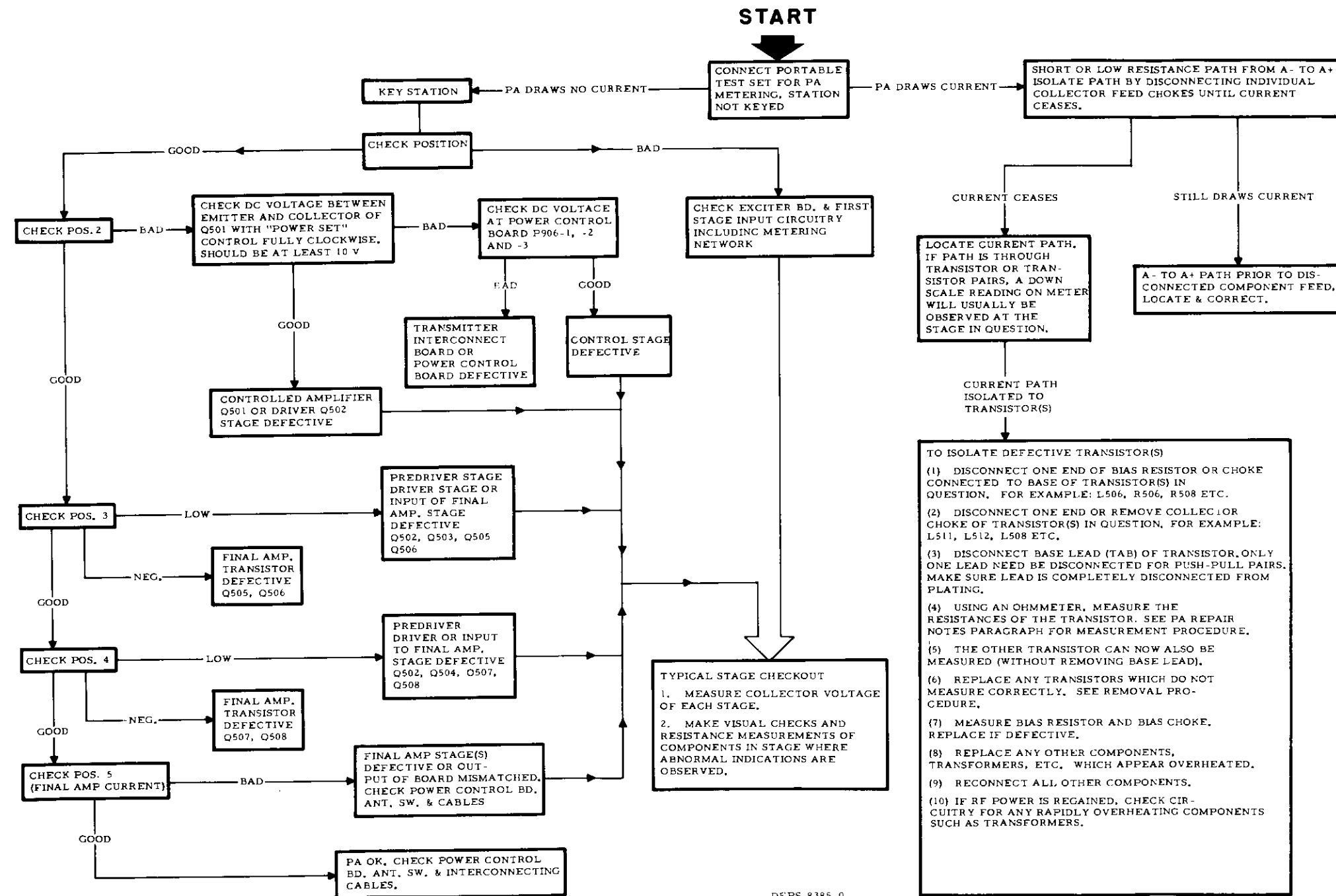

DEPS-8385-0

parts list

TRN5566A Input Bracket PL-8193-A

REFERENCE SYMBOL	MOTOROLA PART NO.	DESCRIPTION
C560, 561, 562	21-410115	capacitor, fixed: +100-0%: unless otherwise stated 220 pF ± 20%; 500 V .01 uF; 250 V 1000 pF; 500 V (feed-thru)
C565, 566	21-84211B01	
C950 thru 953	21-82812H03	
J501	9-84968D01	connector, receptacle: female; single-contact assembly bracket; includes: C950, 951, 952, 953 BRACKET, PA input SOCKET, transistor WASHER, solder; 4 used
J801	1-80764D32	
	7-84355N01	
	9-84935D01 4-83755H01	
P901	15-83498F41 29-83499F01	connector, plug; includes: HOUSING, 4-position TERMINAL; 4 used
Q509	48-889627	transistor: (see note) type M9627 NPN; type M9806
Q901	48-889806	
TB1	31-50378	terminal board: barrier type-2 terminals
W501	1-80727B92 30-83794CD1	assembly cable: assembly rf-input, includes: J501 CABLE, coaxial, WHT; 8" used
mechanical parts		
	2-115968	NUT; 1/4-28 x 3/8 x 1/8"; 2 used
	3-3360	SCREW, tapping; 6-20 x 1/2"; 2 used
	3-8153	SCREW, tapping; 8-15 x 3/4"; 2 used
	3-129841	SCREW, machine; 4-40 x 1/4"
	4-7557	WASHER, flat; .172 x .375 x .033"; 2 used
	4-7678	WASHER, lock; 1/4" external; 2 used
	4-84180C01	WASHER, insulator
	14-865875	INSULATOR, transistor
	14-84391F01	INSULATOR, transistor
	29-5223	LUG, soldering; 2 used
	43-82980N01	STANDOFF; 2 used
	75-10605A04	CUSHION; foam

TKN8336A Cable Power Amplifier PL-8191-O

REFERENCE SYMBOL	MOTOROLA PART NO.	DESCRIPTION
J803	9-844508	connector: female; single-contact (BNC) male; single-contact (phono)
P602	28-82365D03	
W801	1-80727B98	assembly rf output includes: J803 and P602 CABLE, coaxial, WHT; 8" used
	30-82921H01	

TRN5585A Exciter Control Voltage Regulator PL-8192-O

REFERENCE SYMBOL	MOTOROLA PART NO.	DESCRIPTION
C301, 302	21-11021H06	capacitor, ± 80-20%; 50 V: .033 uF
J901	28-82984N04	connector, plug: male; 4-contact
R304	18-83083G11	resistor, variable: 2.5k
mechanical parts		
	9-80028A01	SOCKET, 3 pin

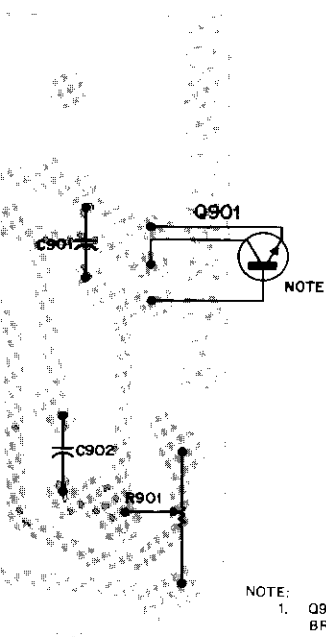

NOTE:
1. Q901 IS MOUNTED TO AN INPUT BRACKET WHICH IS P/O TLN2424A

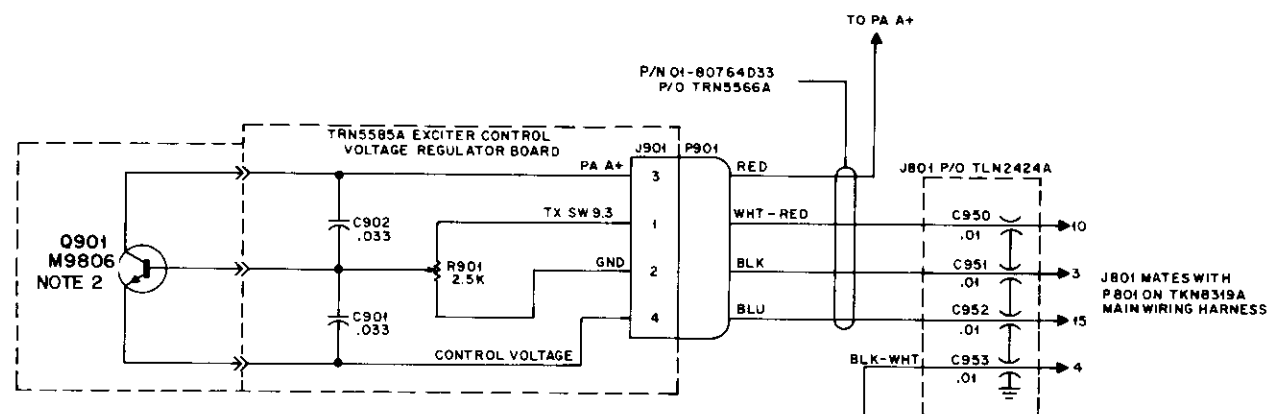

NOTES
1. UNLESS OTHERWISE INDICATED: RESISTOR VALUES ARE IN OHMS; CAPACITOR VALUES ARE IN MICROFARADS.
2. Q901 IS MOUNTED TO AN INPUT BRACKET WHICH IS P/O TLN2424A.

BEPS-35244-0

SOLDER SIDE 8D-BEPS-35245-0
VN FROM SOLDER SIDE 0L-BEPS-35246-0

Model Complement

Model	KH	Description
TLN2424A		Power Amplifier Input Bracket Assembly
TRN5566A		PA Input Bracket
TKN8336A		Power Amplifier Cable
TRN5585A		Exciter Control Voltage Regulator

TRN5585A Exciter Control Voltage Regulator
P/O TLN2424A Power Amplifier Input Bracket Assembly
Schematic Diagram, Circuit Board Detail, and
Parts Lists
Motorola No. PEPS-35247-A
1/14/83- V & G

POWER AMPLIFIER - CONTINUOUS DUTY

electrical parts list

TLD5960A Power Control Board (High Power) PL-8266-O

REFERENCE SYMBOL	MOTOROLA PART NO.	DESCRIPTION
C601, 602, 604 thru 608	21-83596E10	capacitor, fixed: ± 20%; 500 V; unless otherwise stated 220 pF
C610	21-82372C04	.05 uF + 80-20%; 25 V
C611, 612, 614, 615	21-83596E10	220 pF; 500 V
C616	23-83214C04	1.0 uF ± 20%; 15 V
C617	21-82133G53	5 pF ± 0.5 pF; 500 V; NPO
C618 thru 624	21-83596E10	220 pF ± 20%; 500 V
C625	21-82187E14	.001 uF ± 10%; 100 V
CR601	48-83654H01	silicon
CR602	48-83696E04 or 1-80709D68	silicon Zener (9.1 V) hybrid assembly
CR603	48-84616A01	silicon
CR604, 605, 606	48-82392B18	silicon
CR607	48-84616A01	silicon
CR608	48-82392B03	silicon
CR609	48-82392B18	silicon
E601	58-84685B01	coupler, line: dual
IC601	51-84320A02	integrated circuit: M2002
J601	28-84227B02	connector, receptacle: male; single-contact
J602	9-84231B02	female; single-contact
J603	9-84207B01	female; 7-contact
L602	76-83960B01	coil, rf: ferrite bead
L603	24-83961B01	choke
L604	76-83960B01	ferrite bead
Q601	48-869641	transistor: PNP; type M9641
Q602	48-869570	NPN; type M9570
R601	17-82291B21	resistor, fixed ± 10%; 1/4 W; unless otherwise stated 100 ± 5%; 3 W
R603	6-124C49	1k
R604	6-124C19	56
R605	6-124A45	680 ± 5%
R606	6-124A83	27k ± 5%
R607	6-124C97	100k
R608	6-124A45	680 ± 5%
R609	6-124A63	3.9k ± 5%
R610	18-83083G26	variable; 50k
R611	18-83083G20	variable; 50k
R612	6-124A21	68 ± 5%
R613	6-124A49	1k ± 5%
R614	6-124A39	390 ± 5%
R615	6-124C75	12k
R616	6-124A21	68 ± 5%
R617	6-124A57	2.2k ± 5%
R618	6-124A45	680 ± 5%
R619	6-124A27	120 ± 5%
R620	6-124C49	1k
R621	6-124A89	47k
R622	6-124A89	47k ± 5%
R623	6-185A93	68k ± 5%; 1/8 W
R624	6-185B99	47k; 1/8
R625	6-185A73	10k ± 5%; 1/8 W
mechanical parts		
3-139506	42-84284B01	SCREW, tapping; 4-40 x 5/16"; 4 used
55-84300B04		RETAINER; 4 used
		HANDLE

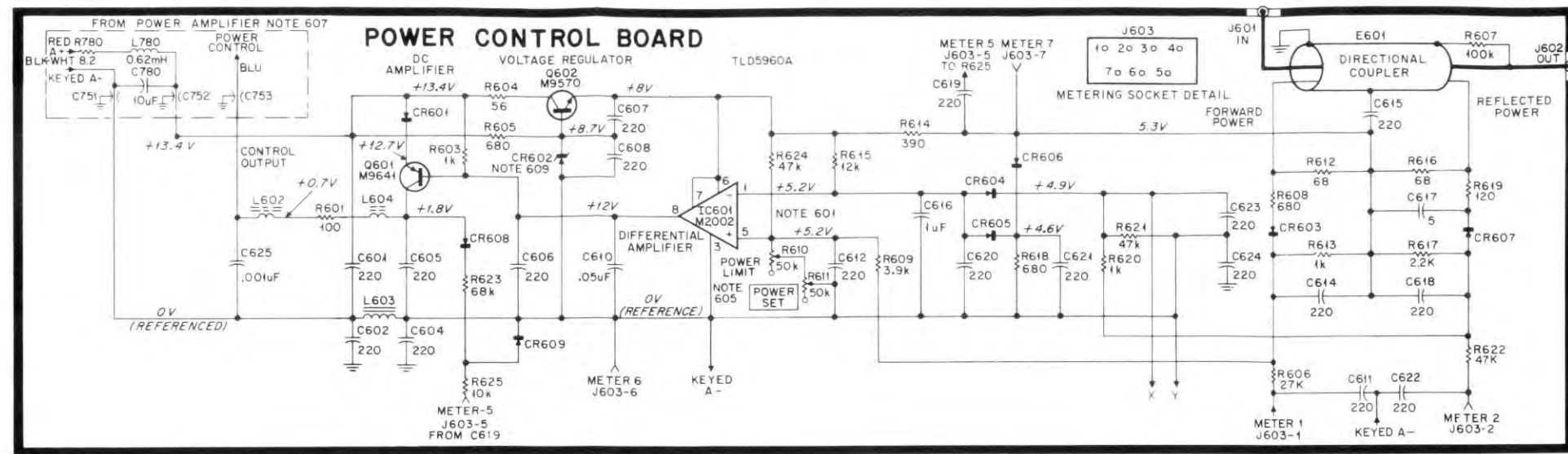

EEPS-35250-0

NOTES:

- 601. Voltages at pins 1 and 5 should differ by less than 50 mV.
- 603. Typical Voltages under normal operating conditions.
- 604. Unless otherwise stated: capacitor values are in picofarads.
- 605. Factory adjustment.
- 607. Not part of or mounted on power control board. Part of Model TRN5577A P.A. casing and hardware.
- 609. On model TLD5960A CR602 is a hybrid assembly.

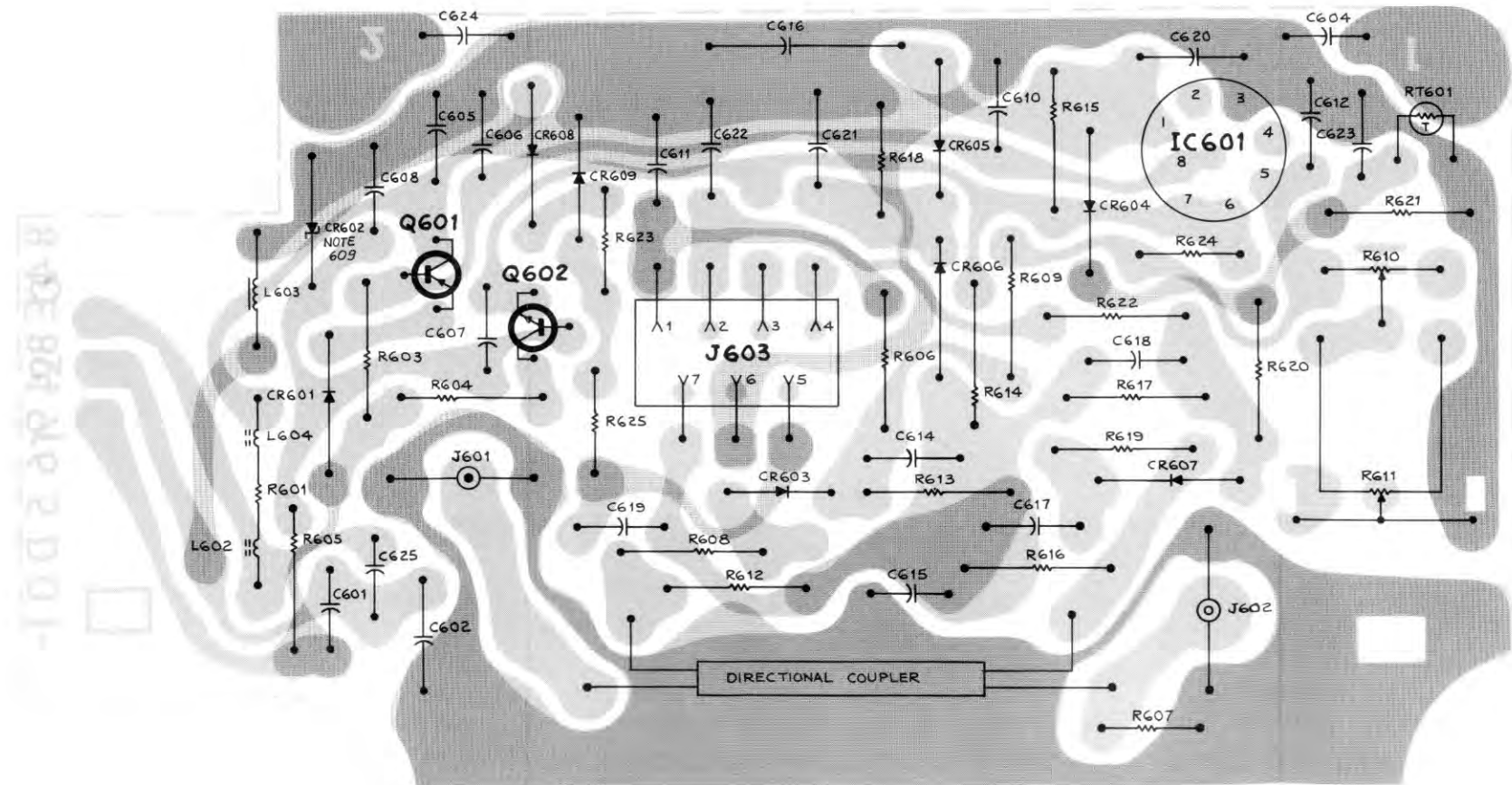

SHOWN FROM SOLDER SIDE

COMPONENT SIDE
SOLDER SIDE

OL-CEPS-16 813-C

parts list

Mechanical Parts List PL-854-D

CODE	MOTOROLA PART NO.	DESCRIPTION
1	42-84284B01	RETAINER; 4 used
2	3-139506	SCREW, tapping; 4-40 x 5/16"
3	29-84028H01	TERMINAL, male; 3 used
4	42-84678B01	CLIP, component
non-coded items		
	55-84300B04	HANDLE, plastic
	1-80797B34	CABLE ASSEMBLY (TLD8610AV & TLD8620AV only) includes:
	42-10217A02	STRAP, tie

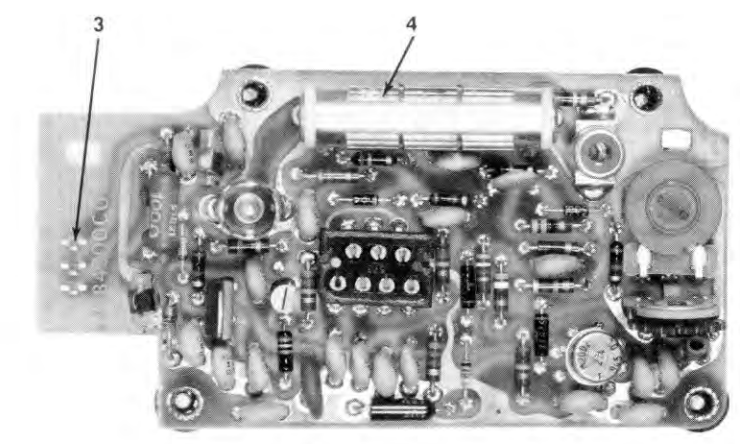
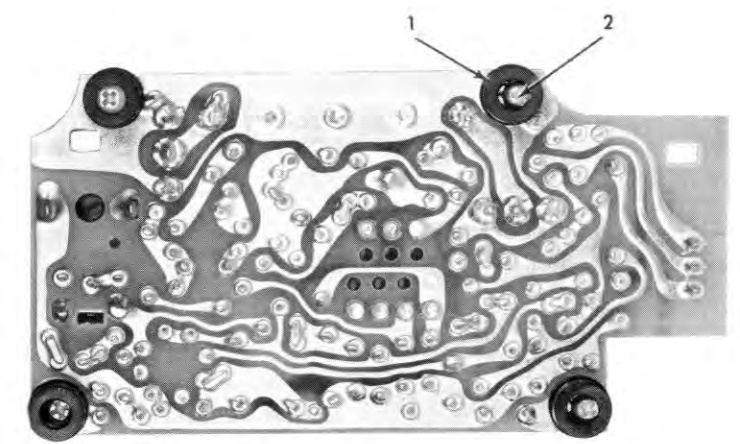

BEPS-6542-O

TLD5960A Power Control Board
Schematic Diagram, Circuit Board Detail, and
Parts Lists
Motorola No. PEPS-35251-O
11/15/82 - V & G

PA COMPONENT VALUES			
REF	136-150.8 MHz	150.8-162 MHz	162-174 MHz
C501	4-40	1.5-18	1.5-18
C502	2.4-27	2-19.3	2-19.3
C505	62	49	62
C506	62	51	34
C508	160	130	130
C509	15	15	10
C510	175	51	39
C511	62	51	39
C513	160	130	130
C515	-	3.3 uF	3.3 uF
C518	49	60	49
C519	49	60	43
C520	30	25	20
C521	62	43	43
C522	56	39	51
C523	80	100	120
C524	-	.01 uF	.05 uF
C526	-	.01 uF	.05 uF
C527	43	30	24
C528	75	75	80
C529	60	51	51
C531	43	30	24
C532	75	75	80
C533	62	60	68
C536	220	390	-
C537	130	150	100
C538	130	150	120
C541	220	130	130
C542	130	150	100
C543	120	130	100
C546	1200	1200	1200
C547	1200	1200	1200
C548	160	130	130
C551	160	130	130
C552	15 uF	100 uF	100 uF
C556	30	6	6
C557	-	-	4.7 uF
C571	-	.068 uF	.068 uF
L503	7-8440B03	1-1/2 turns	1-1/2 turns
L504	1 turn	1 turn	85
L506	.039 uH	.039 uH	290 nH
L507	2-1/2 turns	4-1/2 turns	4-1/2 turns
L508	2-1/2 turns	4-1/2 turns	4-1/2 turns
L509	0.29 uH	.039 uH	290 nH
L510	0.29 uH	.039 uH	290 nH
L511	4-1/2 turns	4-1/2 turns	0.29 uH
L512	4-1/2 turns	4-1/2 turns	0.29 uH
R501	100k	150k	150k
R502	10	10	49
R511	2.7	2.7	-
R514	-	100	51
R515	-	100	51
R528	-	-	2.7
T503	25-84859L01	25-84854L02	24-82060L01
T504	25-84859L02	25-84854L02	24-82060L01
T505	25-84860L01	25-84860L01	25-84861L01
T506	25-84860L01	25-84860L01	25-84861L01

EPS-26749-O

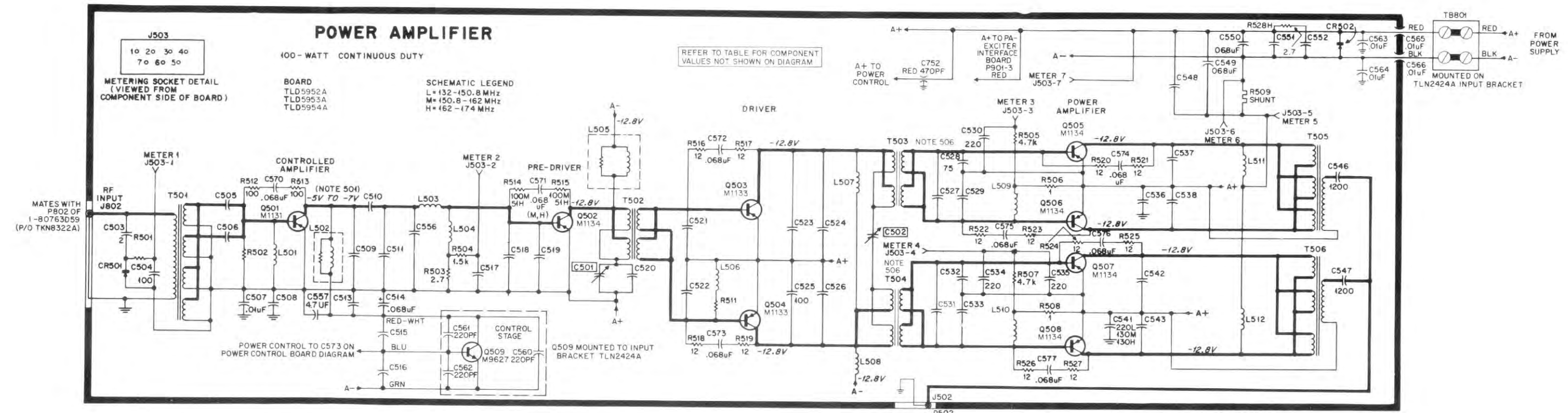
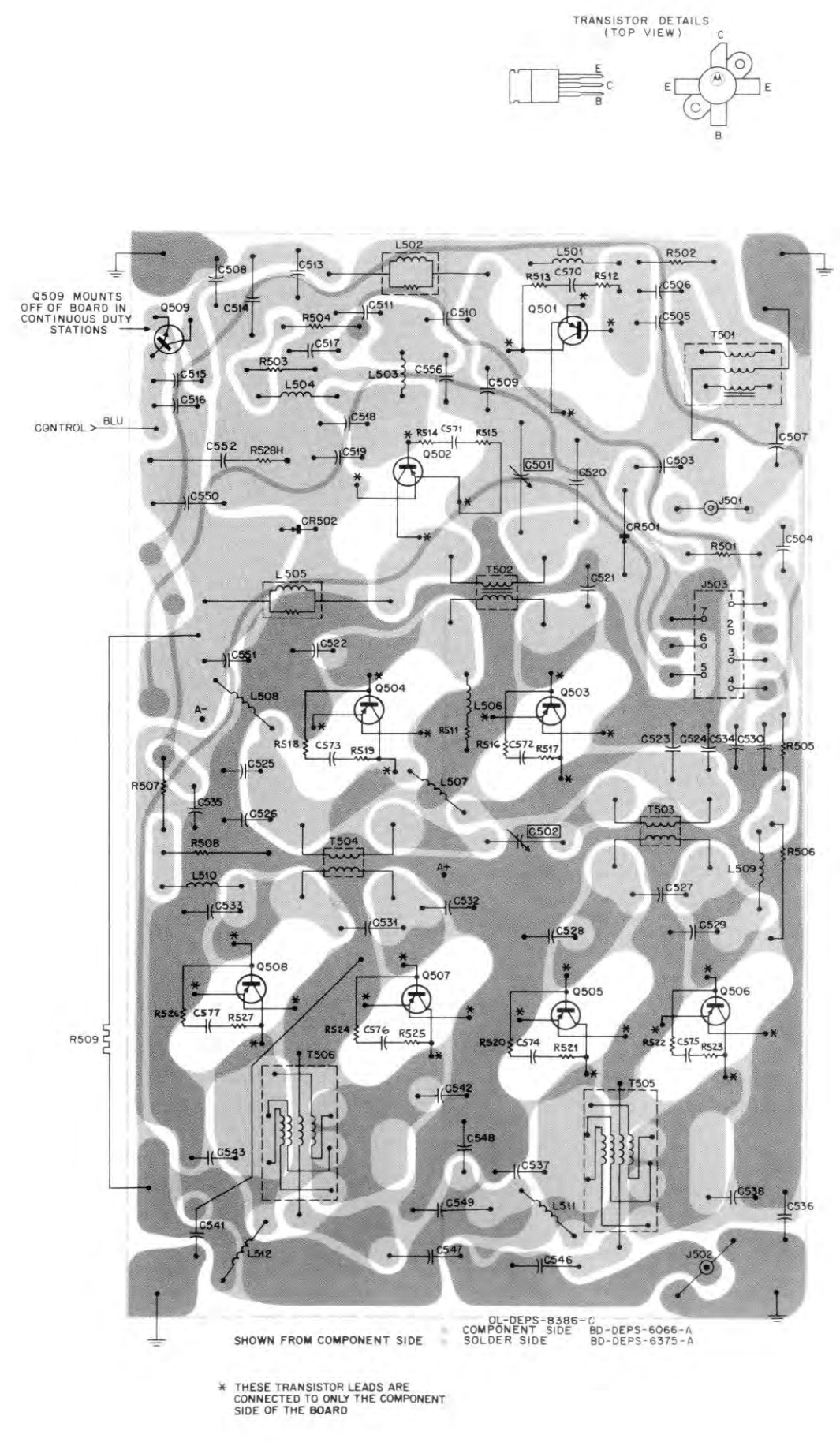

PARTS LISTS SHOWN ON BACK OF THIS DIAGRAM

TLD5950A Series Power Amplifier Board
Schematic Diagram, Circuit Board Detail, and Parts Lists
Motorola No. PEPS-35249-O
11/15/82 - V & G

POWER AMPLIFIER - CONTINUOUS DUTY

parts list

TRN5577A PA Casting and Hardware Kit PL-8218-O

REFERENCE SYMBOL	MOTOROLA PART NO.	DESCRIPTION
C563, 564 C780	21-84211B02 23-83214C20	capacitor, fixed: .01 uF + 100-0%; 250 V 10 uF ± 20%; 20 V
L780	24-80900A61	coil, rf: choke; 0.62 mH
R780	8-124B67	resistor, fixed: 8.2 ± 5%; 1/4 W
mechanical parts		
	2-119913	NUT, 6-32 x 11/32 x 1/8"; 2 used
	3-131195	SCREW, machine; 6-32 x 3/8"; 18 used
	3-134184	SCREW, tapping; 4-40 x 5/16"; 8 used
	3-134185	SCREW, tapping; 6-32 x 1/4"; 4 used
	3-138930	SCREW, tapping; 4-40 x 1/2"; 4 used
	3-83677N04	SCREW, capture; 4 used
	4-7557	WASHER, flat, .172 x .375 x .033; 4 used
	4-801846	WASHER, insulator; 3/8"; 2 used
	7-84347N01	BRACKET, mounting; (RH)
	7-84347N02	BRACKET, mounting; (LH)
	15-84403D01	COVER, power control
	28-84404D03	HEAT EXCHANGE, PA
	31-131744	TERMINAL, strip; 2 insulated #2 mounting
	42-84328E01	CLIP
	66-106515	WRENCH, Allen

TRN5586A PA Hardware PL-8219-O

REFERENCE SYMBOL	MOTOROLA PART NO.	DESCRIPTION
C751, 752, 753	21-821474	capacitor, fixed: ± 20%; 500 V: 470 pF; (feed-thru)
Q501 Q502 Q503, 504 Q500 thru 506	48-84411L31 48-84411L32 48-84411L33 48-84411L34	transistor: (see note) PNP; type M1131 PNP; type M1132 PNP; type M1133 PNP; M1134
mechanical parts		
	3-114406	SCREW, cap; 4-40 x 5/16"; 20 used
	3-134184	SCREW, tapping; 4-40 x 5/16"; 3 used
	14-84290B02	INSULATOR
	26-84811L01	SHIELD, PA
	42-10217A02	STRAP, tie: .091 x 3.62 nylon; 3 used
	54-84429N01	LABEL, PA
	4-83755H01	WASHER, solder; 7 used
	7-82379M01	BRACKET
	9-84234E10	CONNECTOR, receptacle; 3 used

PA Output (Harmonic) Filter PL-1722-O

REFERENCE SYMBOL	MOTOROLA PART NO.	DESCRIPTION
Z502L	TFD6101A	filter, rf; low pass: 132-150.8 MHz
Z502M, 502H	TFD6102A	150.6-174 MHz

LEGEND:
L = 132-150.8 MHz
M = 150.6-182 MHz
H = 162-174 MHz

TLD5952A PA Board (132-150.8 MHz)
TLD5953A PA Board (150.6-182 MHz)
TLD5954A PA Board (162-174 MHz) PL-6100-A

REFERENCE SYMBOL	MOTOROLA PART NO.	DESCRIPTION
C501L	20-83201B09	capacitor, fixed: pF; ± 5%; 500 V: unless otherwise stated
C501M, 501H	20-83201B07	variable; 4-40
C502L	19-83491E08	variable; 1.5-18
C502M, 502H	19-83491E07	variable; 2.4-27 (voltage not stated)
C503	21-83406D52	variable; 2-19.3 (voltage not stated)
C504	21-84494B04	2
C505L	21-84494B02	100
C505M	21-84494B25	62
C505H, 506L	21-84494B02	49
C506M	21-84494B01	62
C506H	21-84494B30	51
C507	21-82428B59	34
C506L	21-84494B51	.01 uF + 80-20%; 200 V
C508M, 508H	21-84494B26	160
C509L, 509M	21-84494B36	130
C509H	21-84494B29	15
C510L	21-84494B09	10
C510M	21-84494B01	175
C510H	21-84494B24	51
C511L	21-84494B02	39
C511M	21-83366K20	62
C511H	21-84494B24	51
C513L	21-84494B51	39
C513M, 513H	21-84494B26	160
C514, 549, 550	6-83813H05	130
C515L		.068 uF ± 10%; 100 V
C515M	23-11019A16	NOT USED
C516M	23-83908L01	4.7 uF; 35 V
C516L, 516H	23-83214C10	100 uF; 25 V
C517	21-83596E10	47 uF ± 20%; 8 V
C518L	21-84494B25	220
C518M	21-84494B35	49
C518H, 519L	21-84494B25	60
C519M	21-84494B35	49
C519H	21-84494B26	60
C520L	21-84936A06	43
C520M	21-84936A04	30 ± 1.5 pF; 2000 V
C520H	21-84936A03	25; 2000 V
C521L	21-84494B02	20; 2000 V
C521M, 521H	21-84494B28	62
C522L	21-84494B45	43
C522M	21-84494B24	56
C522H	21-84494B01	39
C523L	21-83366K12	51
C523M	21-83366K13	80; 250 V
C523H	21-83366K14	100; 250 V
C524L, 526L		120; 250 V
C524M, 526M	21-82428B59	NOT USED
C524H, 526H	21-82372C04	.01 uF + 80-20%; 200 V
C525	21-83366K13	.05 uF + 80-20%; 25 V
C527L	21-83366K19	100; 250 V
C527M	21-83366K18	30
C527H	21-83366K17	43
C528L, 528M	21-83366K24	24
C528H	21-83366K25	75
C529L	21-83366K21	80
C529M, 529H	21-83366K20	80
C530	21-83596E10	51
C531L	21-83366K19	220
C531M	21-83366K18	43
C531H	21-83366K17	30
C532L, 532M	21-83366K24	24
C532H	21-83366K25	75
C533L	21-83366K22	80
C533M	21-83366K21	62
C533H	21-83366K23	60
C534, 535	21-83596E10	68
C536L	21-84494B12	220
C536M	21-84494B18	220
C536H		390
C537L	21-83366K15	NOT USED
C537M	21-83366K16	130; 250 V
C537H	21-83366K13	150; 250 V
C538L	21-83366K15	100; 250 V
C538M	21-83366K18	130; 250 V
C538H	21-83366K14	150; 250 V
C541L	21-84494B12	120; 250 V
C541M, 541H	21-84494B26	220
C542L	21-83366K15	130
		130; 250 V

REFERENCE SYMBOL	MOTOROLA PART NO.	DESCRIPTION
C542M	21-83366K16	150; 250 V
C542H	21-83366K13	100; 250 V
C543L	21-83366K14	120; 250 V
C543M	21-83366K15	130; 250 V
C543H	21-83366K13	100; 250 V
C548, 547	21-84426B36	1200
C548L	21-84494B51	160
C548M, 548H	21-84494B26	130
C551L	21-84494B51	160
C551M, 551H	21-84494B26	130
C552L	23-83214C02	15 uF ± 20%; 25 V
C552M	23-84669A19	100 uF + 150-20%; 20 V
C552H	23-82783B04	100 uF ± 20%; 25 V
C556L	21-84494B33	30
C556M	21-84494B29	10
C556H	21-84494B74	6
C557H	23-82783B25	4.7 uF ± 10%; 25 V
semiconductor device, diode: (see note)		
CR501	4882139G01	germanium
CR502	48-82525G01	silicon
connector, receptacle; female:		
P501, 502	28-84227B01	coaxial, miniature type
J503	9-84207B01	7-contact
coil, rf:		
L501	24-83981B01	choke; 3 turns; coded BRN
L502	24-84392B03	choke; 6 turns
L503L	7-84400B03	inductor "bracket"
L503M, 503H	24-83884G03	1-1/2 turns
L504L, 504M	24-83981B03	choke; 1 turns; coded WHT
L504H	24-82723H18	choke; 85 nH
L505	24-84392B02	choke; 4 turns
L506L, 506M	24-82723H02	choke; 39 nH
L506H	24-82723H20	choke; 290 nH
L507L, 508L	24-8547G10	choke; 2-1/2 turns
L507M, 507H, 508M, 507H	24-84393B02	choke; 4-1/2 turns
L509L, 510L	24-82723H04	choke; 0.29 uH
L509M, 510M	24-82723H02	choke; 39 nH
L509H, 510H	24-82723H20	choke; 290 nH
L511L, 511M	24-84393B02	4-1/2 turns
L511H	24-82723H04	choke; 0.29 uH
L512L, 512M	24-84393B02	4-1/2 turns
L512H	24-82723H04	choke; 0.29 uH
E101M, 102M	76-83960B01	ferrite bead
resistor, fixed: ± 10%; 1/4 W: unless otherwise stated		
R501L	6-124C97	100k
R501M, 501H	6-124D02	150k
R502L, 502M	6-124A01	10 ± 5%
R502H	6-124C17	47
R503	6-124B55	2.7 ± 5%
R504	6-124C53	1.5k
R505, 507	6-124C65	4.7k
R506, 508	6-125D70	1; 1/2 W
R509	6-84232B01	(meter shunt)
R511L, 511M	6-124D55	2.7 ± 5%
R528H	6-124D55	2.7 ± 5%
transformer, rf:		
T501	25-84398B01	pri: 5 turns sec: 4 windings, 1 turn each
T502	25-84397B01	pri: 2 windings, 1-3/4 turns each sec: 2 windings, 1-3/4 turns each
T503L	25-84859L01	pri: 2 windings, 2-3/4 turns each sec: 2 windings, 2-3/4 turns each
T503M	25-84854L01	NOTE: ("left hand" windings) pri: 3-3/4 turns sec: 3-3/4 turns
T503H	24-82060L01	pri: 2 windings, 2 turns each sec: 2 windings, 2 turns each
T504L	25-84859L02	pri: 2 windings, 2-3/4 turns each sec: 2 windings, 2-3/4 turns each
T504M	25-84854L02	NOTE: ("right hand" windings) pri: 3-3/4 turns sec: 3-3/4 turns
T504H	24-82060L01	pri: 2 windings, 2 turns each sec: 2 windings, 2 turns each
T505L, 505M	25-84860L01	pri: 3 windings, 1-1/2 turns each sec: 6 turns
T505H	25-84861L01	pri: 3 windings, 1-1/2 turns each sec: 5 turns
T506L, 506M	25-84860L01	pri: 3 windings, 1-1/2 turns each sec: 8 turns
T506H	25-84861L01	pri: 3 windings, 1-1/2 turns each sec: 5 turns

TRN8069A Resistor-Capacitor Network Kit (132-150.8 MHz)
TRN6445A Resistor-Capacitor Network Kit (150.6-182 MHz)
TLD5502A Resistor-Capacitor Network Kit (162-174 MHz) PL-5396-A

REFERENCE SYMBOL	MOTOROLA PART NO.	DESCRIPTION
C570, 572 thru 577	8-83813H05	capacitor, fixed; ± 10%; 100 V: unless otherwise stated .068 uF
C571L		NOT USED
C571M, 571H	8-83813H05	.068 uF
resistor, fixed: ± 10%; 1/2 W: unless otherwise stated		
R512, 513	6-125C25	100
R514L, 515L		NOT USED
R514M, 515M	6-125C25	100
R514H, 515H	6-125A18	51 ± 5%; 1/2 W
R518 thru 527	6-125C03	12

note: For optimum performance, diodes, transistors, and integrated circuits must be ordered by Motorola part numbers.



ANTENNA SWITCH

MODEL TRN5122A (INTERMITTENT DUTY)
MODEL TRN5571A (CONTINUOUS DUTY)

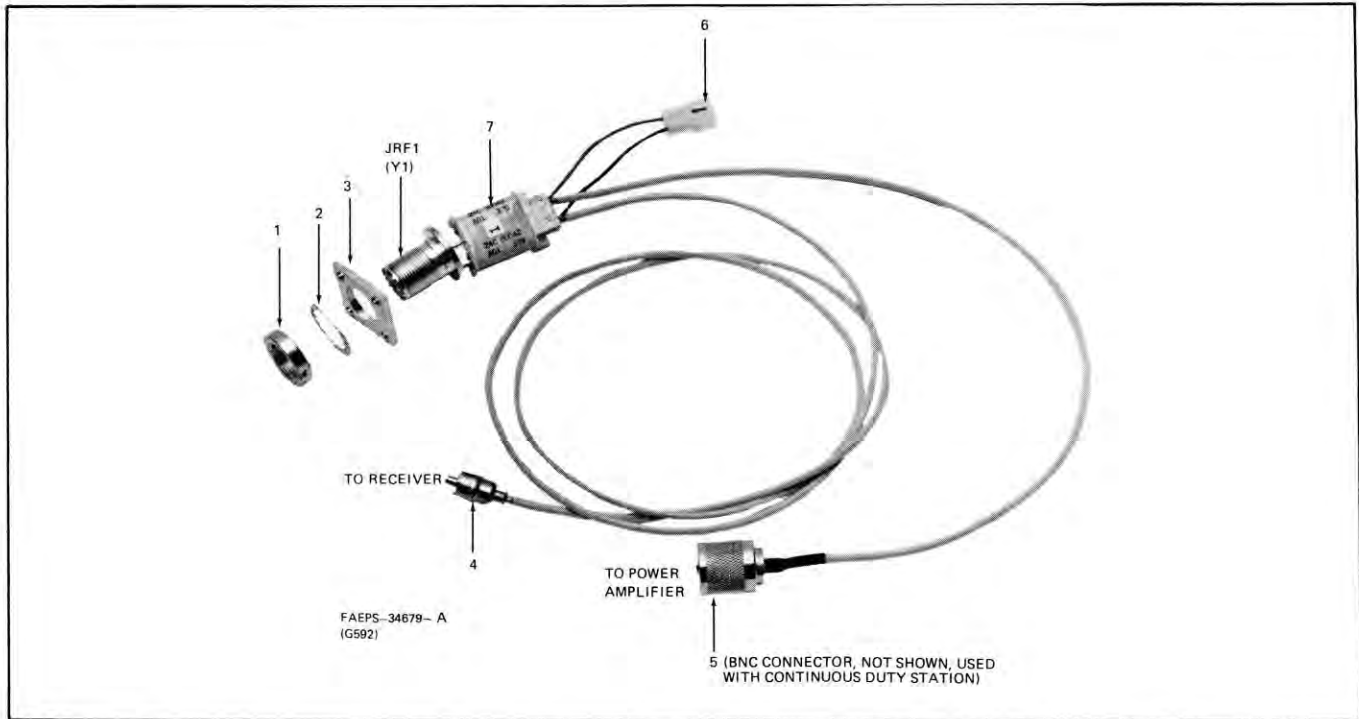

ANTENNA SWITCH REPLACEMENT

1. Remove the card cage per manual instructions in the maintenance section.
2. Note the positions of the tie wraps and cable clamps, and pay attention to cable routing.
3. Remove the appropriate cable clamps, and clip the necessary tie wraps.
4. Remove the antenna switch:
 - 4.1 Unfasten the receiver antenna connector from the card cage chassis (2 screws).
 - 4.2 Disconnect the rf connector from the PA output
 - 4.3 Unfasten the 2 pin molex connector.

- 4.4 Remove the antenna switches spanner nut from the junction box.
5. Installation is the reverse of the above. Remember to fasten the cables with new tie wraps.

parts list

TRN5122A Antenna Switch

PL-8027-A

REFERENCE SYMBOL	MOTOROLA PART NO.	DESCRIPTION
1	2-80006A01	NUT, spanner
2	4-114522	LOCKWASHER, 5/8"
3	43-82895N01	SPACER
4	28-82875N01	CONNECTOR, receiver
5	28-84579F01	CONNECTOR, PA (P803) Intermittent Duty
	28-83099K01	CONNECTOR, PA (P803) continuous duty
6		J801 consists of 15-84861K02 Housing, 29-84706E05 TERMINALS
7		ANTENNA SWITCH, non-serviceable

ANTENNA SWITCH

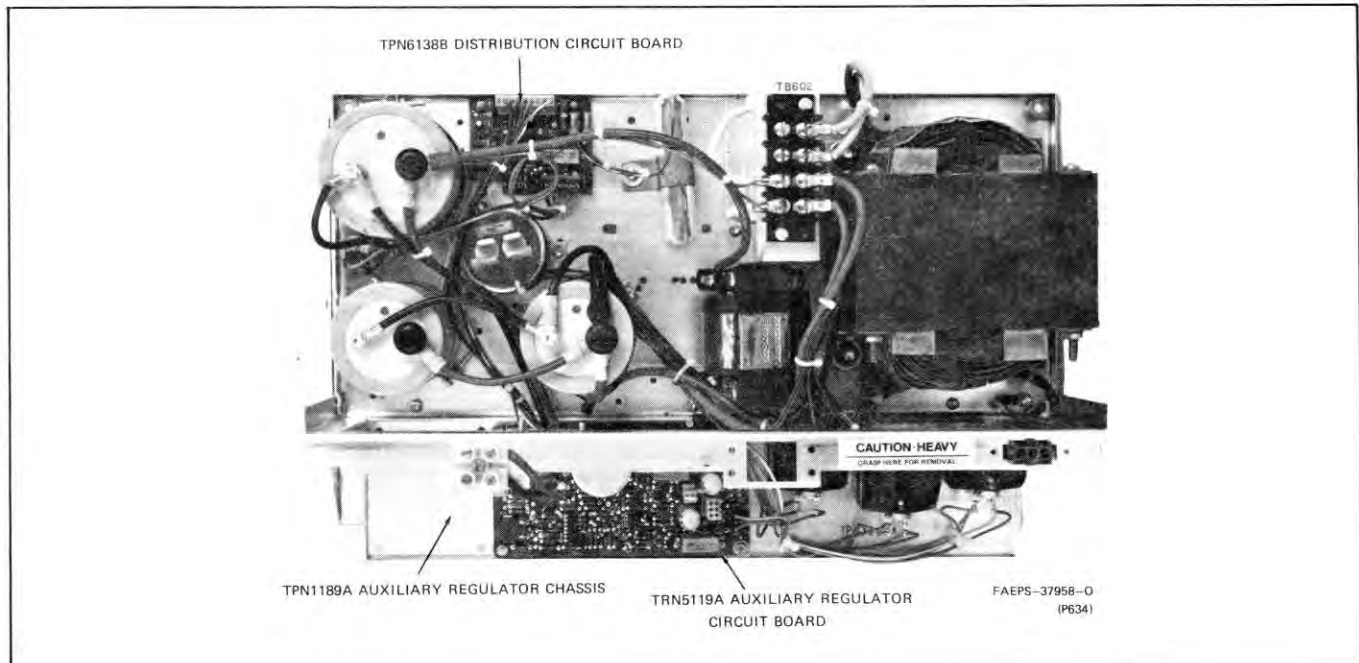

Figure 1. Model TPN1191A Standard Power Supply

1. DESCRIPTION (Refer to Figure 1)

1.1 Model TPN1191A Standard Power Supply is a high efficiency, solid state, power source for operation of base and repeater radio stations. The power supply consists of three main sections: transformer/rectifier/filter, distribution board, and auxiliary regulator board. Refer to Table 1 for the power supply model complement.

1.2 The transformer has a primary winding, a high current secondary winding, and a resonant secondary winding. Under normal operations, the current in the resonant winding causes the transformer core to saturate, limiting the transformer output voltage. Rectifying and filtering the transformer output produces a stable direct current output.

1.3 The distribution board consists of four power supply fuses and circuitry for overvoltage protection. Transistorized circuitry senses a high dc voltage and adds loading for voltage reduction.

1.4 The auxiliary regulator board consists of two current limited linear series pass regulators. These regulators are set for 9.4 V and 13.9 V. The 9.4 V regulator draws power from the main ferroresonant supply output. The 13.9 V regulator draws full-wave rectified power directly from the ferroresonant transformer.

1.5 The features of this power supply include short circuit protection which is inherent in the ferroresonant power transformer, and overvoltage protection. Refer to Table 2 for performance specifications.

Table 1. Model Complement
For TPN1191A Standard Power Supply

Kit	Sub-Kit	Description
TPN1189A		Auxiliary Regulator Chassis
	TRN5119A	Auxiliary Regulator Circuit Board
	TRN5297A	Hardware Kit
	TRN5299A	Chassis Kit
TPN6138B		Distribution Circuit Board
TRN5335A		Hardware, Interconnect
TRN5336A		Hardware, 500 W
TRN5452A		Hardware, Miscellaneous

2. THEORY OF OPERATION

2.1 TRN5336A STANDARD POWER SUPPLY

The TRN5336A Power Supply performs the conversion of ac line voltage to the dc voltages required by the radio. The supply consists of rectification, filtering, and regulation.

2.1.1 Rectification and Filtering

The secondary voltage of transformer T601 is rectified by CR601 and CR602. Ground connection for the diodes is provided through the heat sink to chassis. Output filtering is provided by the network of C602, C603, L601, and C604.

2.1.2 Regulation

Line and load regulation is provided by the ferroresonant action in the secondary resonant winding of the power transformer T601. The high voltage winding resonates with C601, causing the secondary to saturate and restrict the secondary output voltage.

2.2 TPN6138B DISTRIBUTION BOARD

The TPN6138B Distribution Board provides overcurrent and overvoltage protection for the power supply. Refer to the functional and schematic diagrams for circuit details. Secondary voltage fusing is provided by F602 thru F605. Overvoltage protection is provided by a surge protection circuit consisting of Q601 thru Q604. A surge in excess of 18 V causes VR601 to conduct. Forward bias current through R602 and base-emitter junction of Q604, turns on Q604. The other transistors turn on, and the chassis mounted R601 acts as a pull-down load for the line voltage surge.

2.3 TRN5119A AUXILIARY REGULATOR BOARD

The TRN5119A Auxiliary Regulator Board provides regulated 9.4 V and 14 V for the radio. The board circuitry consists of a reference voltage, 9.4 V and 14 V regulators, temperature compensated overcurrent amplifier, and a local control inhibit inverter.

Table 2. Performance Specifications

Operating Temp	-30° to +80°C
Input Voltage	96-132 V, 60 Hz
Line Current*	8A max. at full rated power supply output

HIGH CURRENT OUTPUT

Steady State Output Voltage	13.1 to 16.3 Vdc (36A to 2A)
Output Current	30.4A at 14.1 V
Load Transient	Shall not drop below 11.5 V for a 2A to 36A transient
Output Ripple	50 mV p-p, 25°C to +80°C Derate to 100 mV p-p at -30°C

9.4 OUTPUT

Output Voltage	9.4 V dc set nominal (9.1-9.7 Adjustable)
Output Ripple	Less than 10 mV rms when installed in station
Line Regulation	Shall not change more than 50 mV over input range
Load Regulation	Shall not change more than 150 mV from no load to full load
Max. Output Current	1.1A at +80°C
Current Limit	2.3A typ at 25°C
Short Circuit Current	0.77 max @ 25°C

14 V OUTPUT

Output Voltage	13.9 set nominal (13.5-14.1 Adjustable)
Output Ripple	Less than 10 mV rms when installed in station
Line Regulation	Shall not change more than 25 mV over input voltage
Load Regulation	Shall not change more than 175 mV from no load to full load
Max. Output Current	1.16A at +80°C
Current Limit	2.3A typ at 25°C
Short Circuit Current	0.77A max. @ 25°C

* When calculating primary power requirements do not use Line Current to calculate dissipated power. Use a power meter with provisions for non-unity Power Factor.

SPECIFICATIONS SUBJECT TO CHANGE WITHOUT NOTICE

2.3.1 Reference Voltage

The operational amplifiers on the circuit board requires a stable reference voltage. This reference voltage is produced in two stages of circuitry. The first stage consists of VR4 and R40 which are connected to J1-1 and main 13.8 V. Diode VR4 regulates at 9.6 V. The second stage which operates from this 9.6 V is temperature compensated and consists of VR1, CR2, and R39. The resultant 6.5 V reference is feed to each of the operational amplifiers.

2.3.2 9.4 V Regulator

2.3.2.1 The 9.4 V regulator is a series pass type circuit using a PNP transistor (Q6). A PNP type transistor can provide voltage regulation with as little as 0.7 V differential between collector and emitter. This means that the input voltage can go as low as 10.4 V, and the circuitry will still maintain voltage regulation. The voltage regulator circuitry provides output voltage adjustment, correction for changes of input voltage and load and overcurrent protection.

2.3.2.2 The 9.4 V regulator output voltage (J5-6) is set by the 9.4 V VOLTAGE ADJUST potentiometer, R35. The voltage from R35 goes to U1A-2 and is compared to U1A-3, the reference voltage input. The differential voltage appears at U1A-1. For example, if U1A-2 becomes less positive, the output at U1A-1 becomes more positive, causing Q7 to conduct harder. Increased collector current at Q7 causes increased base-emitter current at Q6. As a result, Q6 conducts harder, with a resultant higher (more positive) regulated output voltage at J5-6.

2.3.2.3 The circuitry described in the previous paragraph is a negative feedback loop. It maintains a constant output voltage for changes in load or input voltage. The feedback loop has typically 40 dB of gain at dc to give a load/line regulation of ± 0.1 V dc maximum from no load to full load. As an example, for an increase in load current, the regulator output voltage would normally decrease. The reduced output voltage is sensed at U1A-2, which is now less positive than U1A-3, the reference voltage. U1A-1 goes more positive and drives Q7 into further conduction. An increase in collector current of Q7 causes increased conduction of Q6 which returns the regulated output voltage to normal. A decrease in load current causes the opposite action.

2.3.2.4 The overcurrent protection circuitry is of the current foldback type. As the load increases beyond the knee, the output voltage and current decrease simultaneously to a final short circuit current of 0.77 amp maximum. The current is sensed across R20. When this voltage exceeds about 0.3 volts (representing a load current of about 2.3 amps), Q8 is forward biased and starts to conduct. Its collector goes positive, causing Q9 to conduct thru R23 and R25. Q9

conducting lowers the voltage at R28 (VREF). As the voltage on U1A-3 lowers, it causes the voltage on U1A-1 to go lower, forcing Q7 and Q6 to conduct less. As a result, the output voltage (9.4 V regulated) decreases. As output current increases, Q8 and Q9 conduct harder resulting in higher Q6 impedance. This action continues until the output voltage decreases to about 6.5 V. At this point, CR10 becomes forward biased, and the emitter current of Q10 increases. This results in an increased voltage across R21. This will forward bias Q8 harder. As a result less output current can be drawn under a short circuit condition. This is desirable because the power dissipated in Q6 is now reduced.

2.3.3 14 V Regulator

2.3.3.1 The 14 V regulator is a series pass type circuit using PNP transistors (Q1 and Q11). A PNP type transistor can provide voltage regulation with as little as 0.7 V differential between collector and emitter. This means that the input voltage can go as low as 14.7 V, and the circuitry will still maintain voltage regulation. The voltage regulator circuitry provides output voltage adjustment, correction for changes of input voltage and load current, and overcurrent protection.

2.3.3.2 The input filter circuitry provides power to the 14 V regulator. CR1 and CR15 rectify ac to dc (26-34 V). Resistors R47 and R48 limit the surge and reduce the ripple current filter capacitor C1.

2.3.3.3 The 14 V regulated (J5-2) is set by the 14 V VOLTAGE ADJUST potentiometer, R7. The voltage from R7 goes to U1C-9 and is compared to U1C-10, the reference voltage input. The differential voltage appears at U1C-8. For example, if U1C-9 becomes less positive, the output at U1C-8 becomes more positive, causing Q2 to conduct harder. Increased collector current at Q2 causes increased base-emitter current at Q1 and Q11. As a result Q1 and Q11 conduct harder, with a resultant higher (more positive) regulated output voltage at J5-2.

2.3.3.4 The circuitry described in the previous paragraph is a negative feedback loop. It maintains a constant output voltage for changes in load or input voltages. The feedback loop has typically 40 dB of gain at dc to give a load/line regulation of ± 0.1 V dc maximum from no load to full load. As an example, for an increase in load current, the regulator output voltage would normally decrease. The reduced output voltage is sensed at U1C-9, which is now less positive than U1C-10, the reference voltage input. U1C-8 goes more positive and drives Q2 into further conduction. An increase in collector current of Q2 causes increased conduction of Q1 and Q11. The regulator output returns to normal. A decrease in load current causes the opposite action.

2.3.3.5 The overcurrent protection circuitry is of the current foldback type. As the load increases

beyond the knee, the output voltage and current decrease simultaneously to a final short circuit current of 0.77 ampere maximum. The current is sensed across R10. When this voltage exceeds about 0.3 volts (representing a load current of about 2.3 amperes), Q3 is forward biased and starts to conduct. Its collector goes positive, causing Q4 to conduct through R13 and R14. Q4 conducting lowers the voltage at R9 (V REF). As the voltage on U1C-10 lowers, it causes the voltage on U1C-8 to go lower forcing Q2, Q1, and Q11 to conduct less. As a result, the output voltage (14 V regulated) decreases. As output current increases, Q3 and Q4 conduct harder, resulting in higher Q1 and Q11 impedance. This action continues until the output voltage decreases to about 6.5 V. At this point, CR5 becomes forward biased, and the emitter current of Q5 increases. This results in an increased voltage across R11. This will forward bias Q3 harder. As a result less output current can be drawn under a short circuit condition. This is desirable because the power dissipated in Q1 and Q11 is now reduced.

2.3.4 Temperature Compensated Overcurrent Amplifier

The temperature compensated overcurrent amplifier (UID) compensates the knee of the 9.4 V and 14 V overcurrent detect circuits (Q3 and Q8). Compensation allows operation from -30°C to $+80^{\circ}\text{C}$ without major degradation in available output current. Compensation begins at diodes CR13 and CR14. These diodes are temperature sensitive, having a voltage decrease of about 2 mV from an increase of each degree centigrade. A temperature increase makes UID-14 less positive. Both Q5 and Q10 reduce collector current with a reduction in voltage drop across R11 and R21. The reduced bias voltage developed across these resistors counteracts the effects of high ambient temperatures on Q3 and Q8.

2.3.5 Local Control Inhibit Inverter

The local control inhibit inverter (U1B) is used to turn off the 9.4 V and 14 V voltage regulators externally for local control operation. When used, jumper JU2 is removed, and J5-5 is connected to ground through the normally closed contacts of a switch. Opening the switch contacts causes U1B-7 to go high. Both Q4 and Q9 are driven into saturation. U1C-8 and U1A-1 are pulled low which cuts off Q6, Q1, and Q11.

3. **REGULATED OUTPUT VOLTAGE ADJUSTMENT PROCEDURE**

The regulated output voltages can be adjusted with the auxiliary regulator board in the radio or on the service bench. If adjusted on the test bench, the regulator must be supplied 14 V at J1-1 and +28 V at J1-6 or J1-7. The outputs must be loaded to 1.1 ampere each.

Step 1. Measure the regulated output voltages at TP101 (9.4 V) and TP111 (14 V).

Step 2. Set R35 for $9.4\text{ V} \pm 0.1\text{ V}$.

Step 3. Set R7 for $13.9 \pm 0.1\text{ V}$.

4. **MAINTENANCE**

4.1 INTRODUCTION

Maintenance and repairs of this power supply demands a thorough understanding of its operation. Refer to the Power Supply Theory of Operation for this information.

4.2 TEST EQUIPMENT REQUIRED

The following test equipment is necessary for efficient, accurate servicing in the event that maintenance is required.

- 3-1/2 digit DVM (Motorola Model R1001A or equivalent).
- DC current meter (50 amperes)
- Load resistor (variable from 0 ohms to 15 ohms, and capable of carrying 50 amperes).
- Variable voltage ac line transformer (0-130 volts).
- Oscilloscope.
- Bench service cord consisting of:

Qty.	Part No.	Description
1	15-83183N01	Housing
2	39-83145N01	Contact
1	39-83145N02	Contact
1	30-865903	Cord

4.3 AUXILIARY REGULATOR CHASSIS REMOVAL (Refer to Figure 2)

The circuitry on the auxiliary regulator chassis can be serviced without removing the entire power supply. The auxiliary chassis below the main chassis can be disconnected and removed separately.

Step 1. Disconnect P1 and P5.

Step 2. Remove the three screws holding the auxiliary chassis to the main chassis. Use a magnetic screwdriver.

Step 3. Lift the auxiliary regulator chassis out of the cabinet.

Step 4. Remove circuit board(s) by compressing the plastic locking tabs.

4.4 POWER SUPPLY REMOVAL (Refer to Figures 2 thru 5)

WARNING

The power supply is unexpectedly heavy, and balances sharply to the right. Follow the removal instructions carefully.

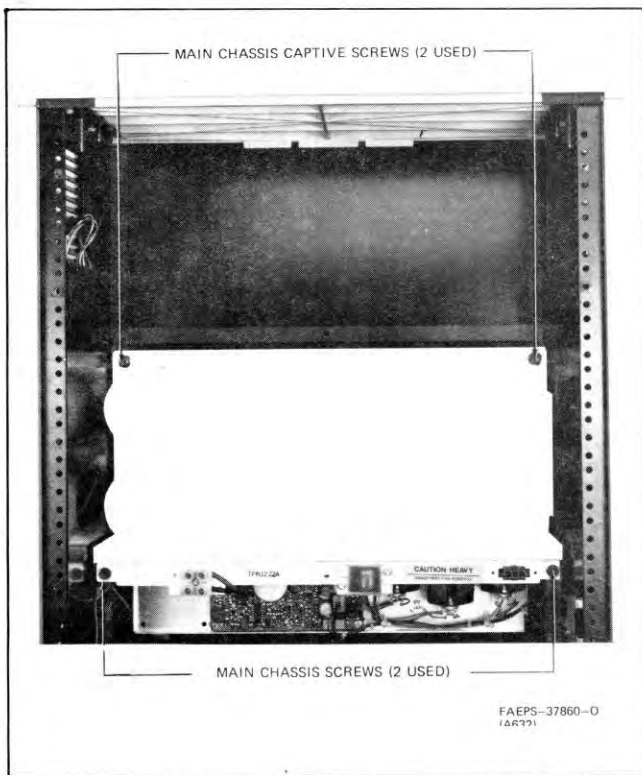

Figure 2. Power Supply Mounting Hardware

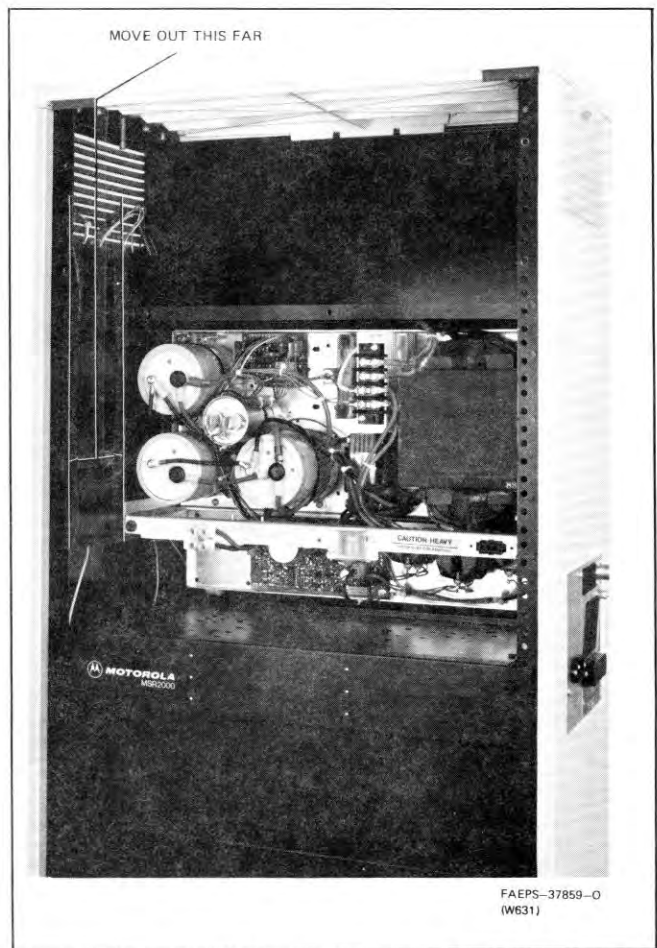

Figure 3. Power Supply Chassis Travel Distance

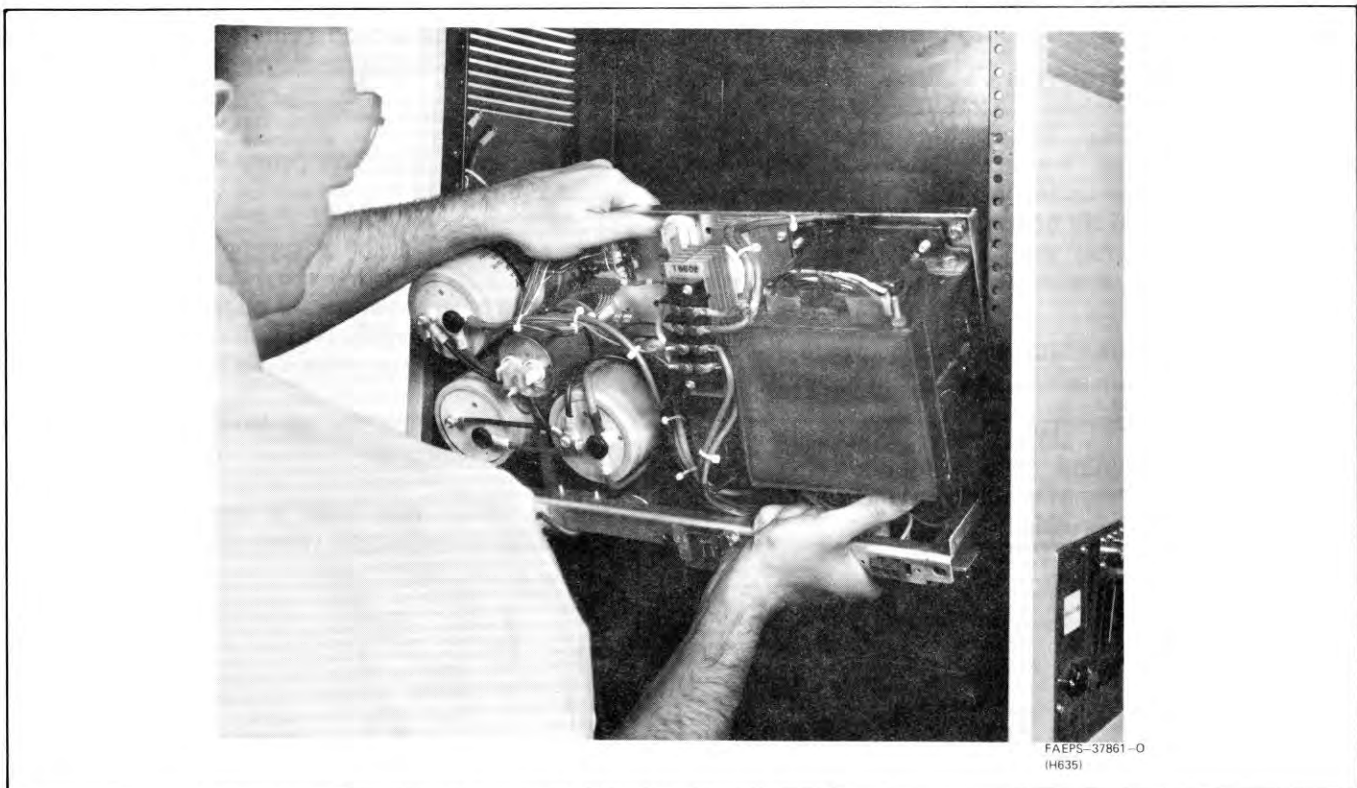

Figure 4. Properly Gripped Chassis

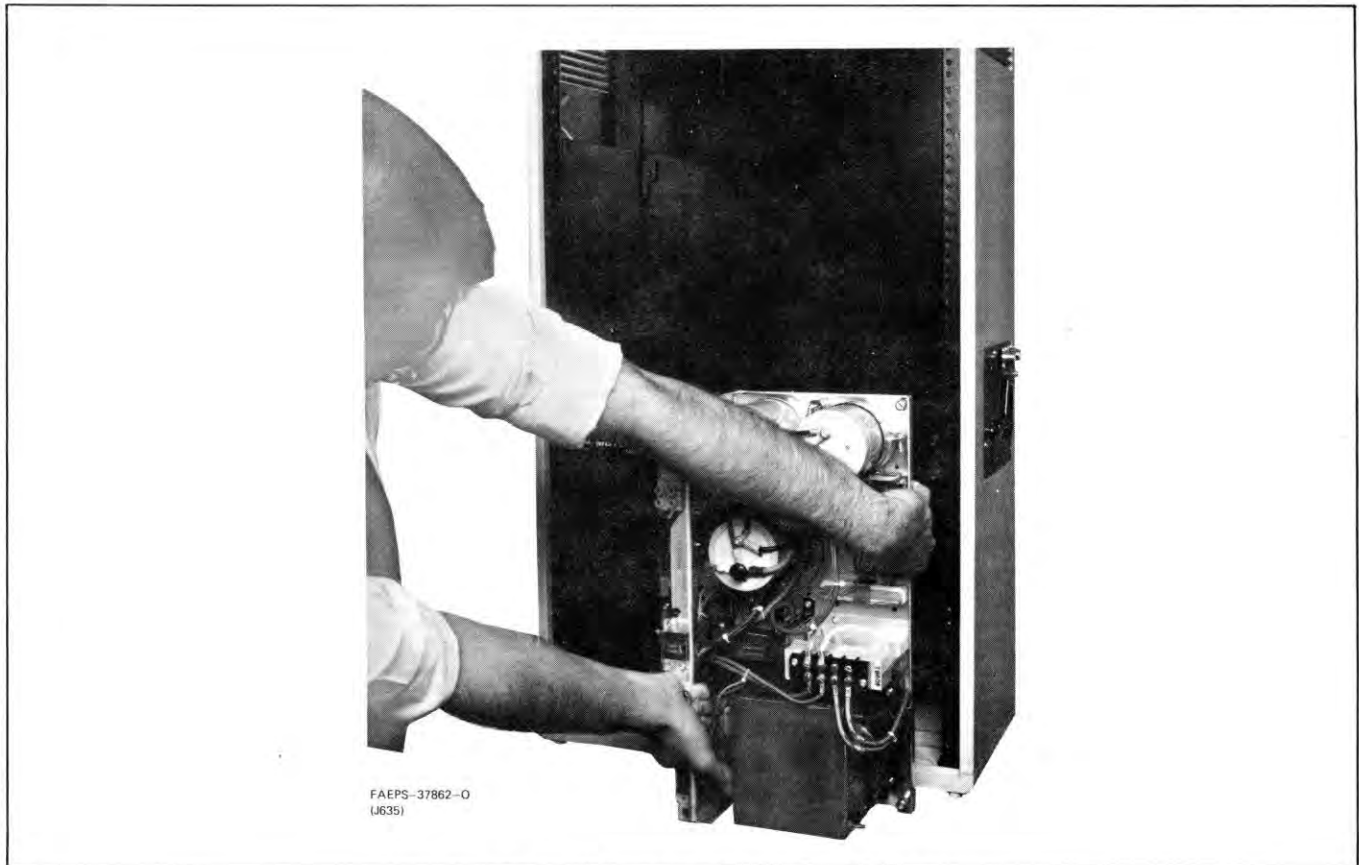

Figure 5. Power Supply Removed From Cabinet

Step 1. Disconnect P5 and P103 (for battery power supply). Open tie wraps and reposition cable.

Step 2. Remove MAIN CHASSIS SCREWS and loosen MAIN CHASSIS CAPTIVE SCREWS. Remove the two shipping screws (Motorola Part No. 3-83498N08) and washers (Motorola Part No. 4-135873) located under the main chassis side rails. These screws need not be replaced when re-installing the power supply unless the station is to be shipped to another location. Retain the screws for further shipping needs.

Step 3. Slide power supply chassis toward you until chassis is flush with cabinet as shown in Figure 3.

WARNING

Do not allow chassis to slide freely beyond front of cabinet: Cabinet rail support ends abruptly.

Step 4. Grip the main chassis with the right hand as shown in Figure 4. Find a comfortable grip around the flattened parts of the metal. Adjacent parts have sharp edges.

Step 5. Plant your feet firmly with good balance to receive a heavy weight.

Step 6. Slide the power supply toward you. Slightly tilt the chassis toward you and reach the left hand over the top to balance the chassis on the cabinet rails. Press the chassis firmly against the rails or the chassis will suddenly slide out of the cabinet. See Figure 5.

Step 7. Reposition the left hand from balancing the chassis to a firm grip.

Step 8. Brace your body to receive a heavy weight, and lift the power supply chassis free of the cabinet.

Table 3. Troubleshooting Chart

Symptom	Corrective Action
A. No output voltage	<ol style="list-style-type: none"> 1) Check primary line connection to supply. 2) Check transformer secondary voltage at TB601. 3) Check power rectifiers CR601 and CR602.
B. No regulated output voltages	<ol style="list-style-type: none"> 1) Check for approximately 14 volts at J1-1. If no voltage, check fuse F603. 2) Check for approximately 6.5 volts at TP105, 6.5 V REF. If no voltage, check CR2 and VR1. 3) Check for grounded CR4 and CR8, REGULATOR INHIBIT lead. 4) Check for defective U1B. 5) Check for defective U1D.
C. 9.4 V regulated output: OK. No 14 V regulated output.	<ol style="list-style-type: none"> 1) Check fuses F605 and F604. 2) Check Q3 and Q4. TP105 should be 6.5 volts. 3) Check U1C. 4) Check Q2 for open circuit. 5) Check Q1 and Q11 for open circuit. 6) Check VR2 for short. 7) Check for short circuit at J5-2.
D. 14 V regulated output: OK. No 9.4 V regulated output	<ol style="list-style-type: none"> 1) Check Q8 and Q9. TP104 should be 6.5 volts. 2) Check U1A. 3) Check Q7 for open circuit. 4) Check Q6 for open circuit. 5) Check VR3 for short circuit. 6) Check for short circuit at J5-6.
E. Regulators cannot supply full rated current of 1.1A (output drops more than 1 volt.)	<ol style="list-style-type: none"> 1) Check U1D, Q3, Q4, Q8 and Q9.
F. Regulators short circuit current greater than 0.8A, and possibly input fuse blowing.	<ol style="list-style-type: none"> 1) Overcurrent detect circuits defective. Check U1D, Q3, Q4, Q8 and Q9. 2) Check CR5 and CR10.
G. Regulated output voltages cannot be adjusted to 9.4 ± 0.1 V and 13.9 ± 0.1 V.	<ol style="list-style-type: none"> 1) Check 6.5 V REF. It should be 6.5 ± 0.2 volts. If not, check CR2, VR1, and VR4. 2) Check regulator feedback loop: U1A, Q7, and Q6; U1C, Q2, Q1 and Q11. 3) Check for high leakage Q2 and Q7.
H. High ac ripple voltage on 14 V regulated output: greater than 10 mV at 1.5A.	<ol style="list-style-type: none"> 1) Check filter capacitor C1 for low capacity or leakage. Ripple voltage at TP100 is greater than 4 V peak-to-peak. 2) Check U1C for low loop gain: less than 20 dB.

parts list

TRN5299A Chassis PL-8013-O

REFERENCE SYMBOL	MOTOROLA PART NO.	DESCRIPTION
Q1,6,11	48-869672	diode: (see note) PNP; type M9672
P3	15-83498F39	connector: HOUSING, 3 position (WHT)
P4	15-83498F40	HOUSING, 3 position (RED)
P7	15-83498F39	HOUSING, 3 position (WHT)
mechanical parts		
	3-136143	SCREW, tapping; 8-32 x 1/4"; 6 used
	43-83561N01	STANDOFF, twist lock; 2 used
	3-136850	SCREW, tapping; 6-32 x 1/2"; 6 used
	9-82973A01	SOCKET, transistor; 3 used
	14-865854	INSULATOR; 3 used
	26-82979N01	HEAT SINK; 3 used
	29-83499F01	TERMINAL; 9 used

note: For optimum performance, diodes, transistors, and integrated circuits must be ordered by Motorola part numbers.

TRN5297A Hardware Kit
TRN5298A Hardware Kit PL-8014-O

REFERENCE SYMBOL	MOTOROLA PART NO.	DESCRIPTION
P6,101	15-83498F38	connector: HOUSING, 2 position
mechanical parts		
	3-134185	SCREW, tapping; 6-32 x 1/4"
	43-82980N01	STANDOFF; 3 used TRN5297A; 5 used TRN5298A
	43-82980N02	STANDOFF, spacer; 2 used TRN5298A
	43-83561N01	STANDOFF, twist lock; 2 used
	1-80754D87	Assembly Wire and Lug includes: (p/o TRN5297A)
	29-83499F01	TERMINAL; 2 used
	1-80754D97	Assembly Wire and Lug includes: (p/o TRN5298A)
	29-83499F01	TERMINAL; 2 used
	1-80754D98	Assembly Wire and Lug includes: (p/o TRN5298A)
	29-83499F01	TERMINAL; 2 used
	42-10217A02	STRAP, ties

TRN5335A Interconnect Hardware Kit PL-8015-B

REFERENCE SYMBOL	MOTOROLA PART NO.	DESCRIPTION
P1,603	15-83498F45	connector: HOUSING, 9 position
R610	17-83389G03	resistor, fixed: $\pm 5\%$; 20 W; unless otherwise stated 15
mechanical parts		
	3-10943M25	SCREW, tapping; M4 x 7 x 20mm; 2 used
	3-83498N04	SCREW, tapping; M4 x 7 x 7mm; 3 used
	42-10217A02	STRAP, tie; 6 used
	29-83499F01	TERMINAL; 14 used
	29-83113N01	TERMINAL, right angle
	29-83113N02	TERMINAL, right angle
	46-84549F01	PLUG, polarizing
	4-7651	WASHER, lock, #8

TRN5452A Miscellaneous Power Supply Hardware Kit PL-8269-O

REFERENCE SYMBOL	MOTOROLA PART NO.	DESCRIPTION
R601	17-82177B65	resistor, fixed: 10 $\pm 10\%$; 50 W
non-referenced items		
	1-80766D012	ASSEMBLY, resistor cable; includes:
	29-83113N02	TERMINAL, right angle; 4 used
	2-10971A17	NUT, hex; M4 x 0.7mm
	3-83497N05	SCREW, machine; M4 x 10mm
	4-7633	WASHER, flat
	4-7651	LOCKWASHER, internal; #8
	43-82980N03	STANDOFF, support; 4 used

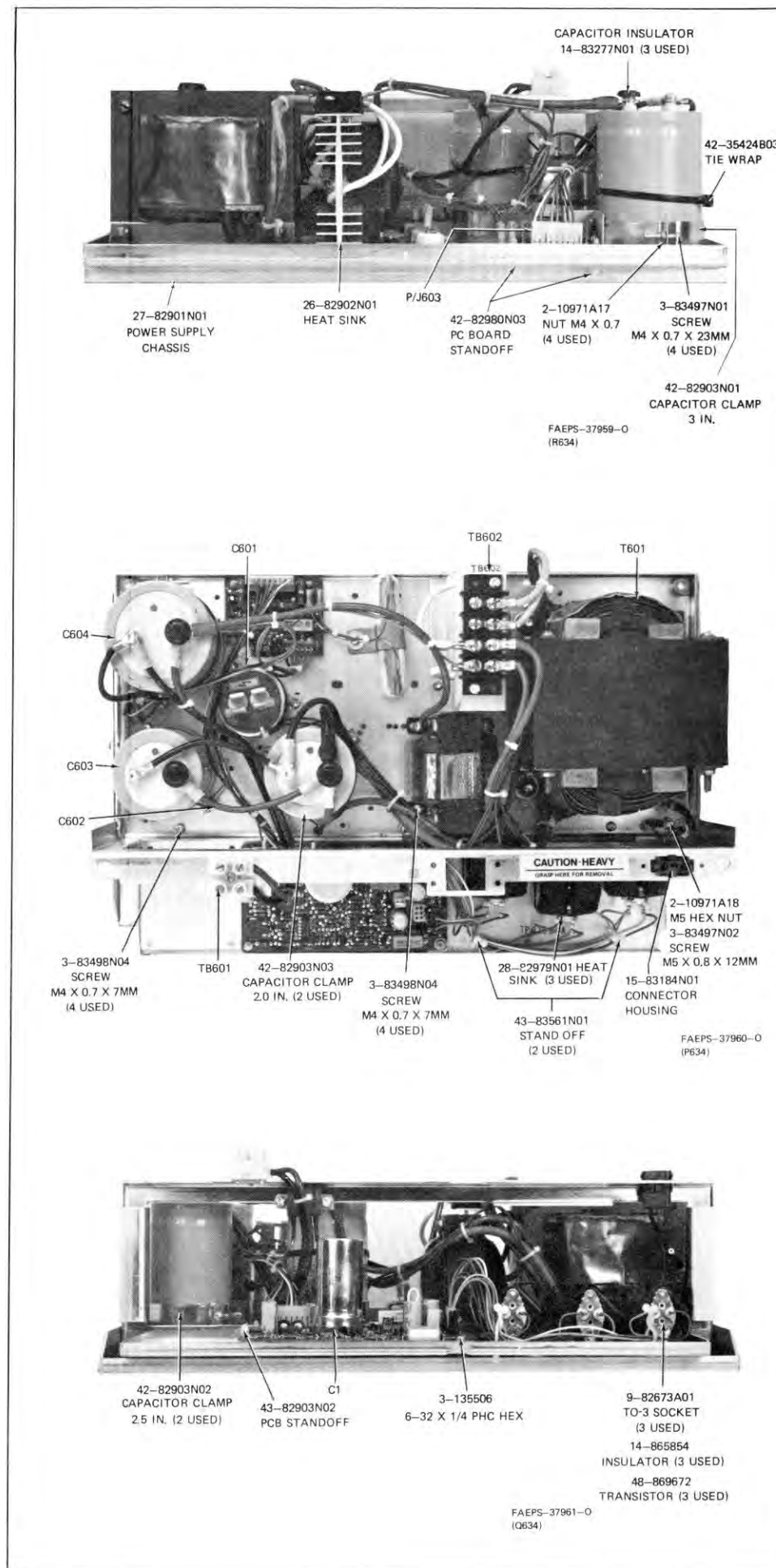

Parts Locations and Lists
Motorola No. PEPS-34739-B
10/31/83 - V & G

STANDARD POWER SUPPLY

MODEL TPN1191A

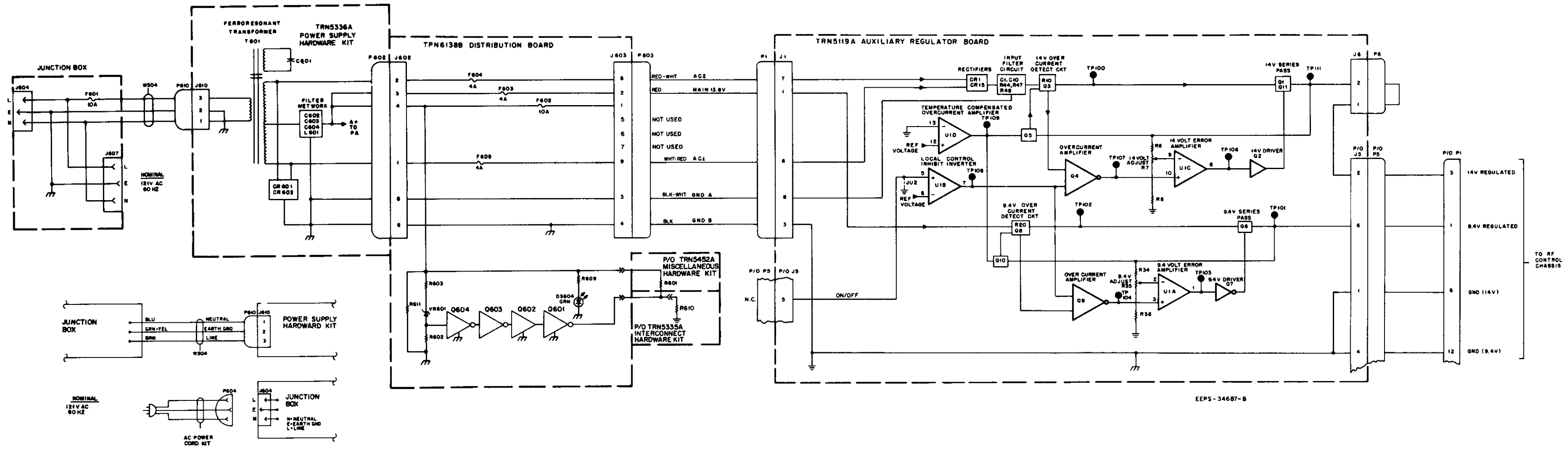

EEPS-34687-B

STANDARD POWER SUPPLY

MODEL TPN1191A

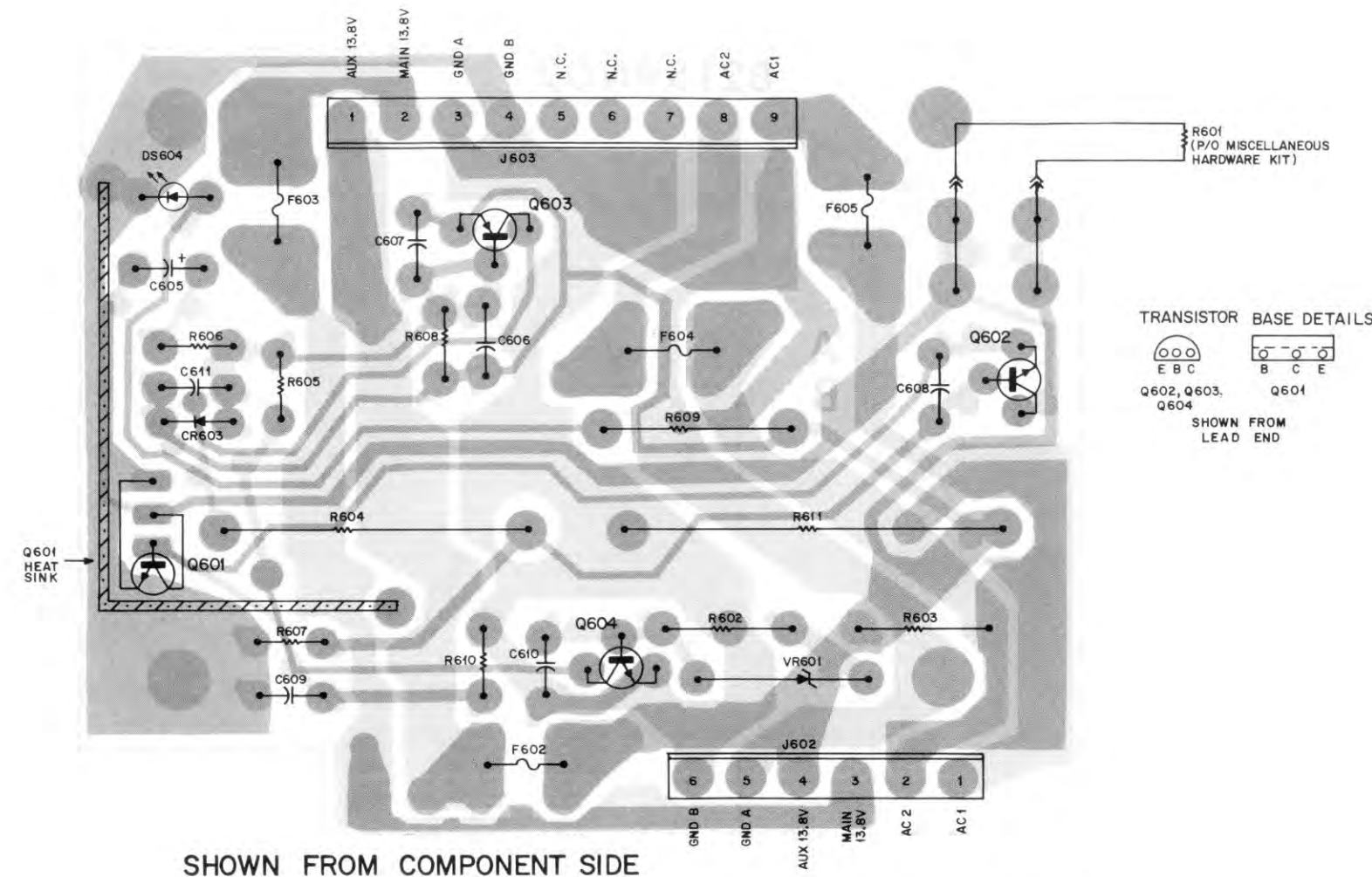

SHOWN FROM COMPONENT SIDE

parts list

TPN6138B Power Supply Distribution Board PL-8265-O

REFERENCE SYMBOL	MOTOROLA PART NO.	DESCRIPTION
C605	23-11019A27	capacitor, fixed: 22 uF ± 20%; 25 V
C606	8-11017B08	.01 uF ± 10%; 50 V
C607 thru 611	21-11014H32	20 pF ± 5%; 100 V
CR603	48-11034D01	diode: (see note) silicon
DS604	48-84404E04	light emitting diode: green
F602	65-139767	fuse: 10 amp; 32 V
F603, 604, 605	65-82859N01	4 amp; 32 V
J602	28-82984N06	connector, plug: male; 6 contact
J603	28-82984N10	male; 9 contact
Q601	48-869806	transistor: (see note) NPN; type M9806
Q602	48-869568	NPN; type M9568
Q603	48-869643	PNP; type M9643
Q604	48-869642	NPN; type M9642
R602	6-11009E25	resistor, fixed ± 5%; 1/4 W: 100
R603	6-11009E37	330
R604	6-127A37	330; 2 W
R605 thru 608	6-11009E69	6.8k
R609	6-125C51	1.2k
R610	6-11009E35	270
R611	17-82177B08	200; 5 W
VR601	48-83461E1B	voltage regulator: Zener; 18 V
mechanical parts		
29-82906N01	29-82906N01	TERMINAL, fuse; 8 used
2-10971A16	2-10971A16	NUT, machine; M3 × 0.5mm
3-83497N04	3-83497N04	SCREW, machine
4-84180C01	4-84180C01	WASHER, shoulder
14-83820M02	14-83820M02	INSULATOR, thermoconductive
29-10231A10	29-10231A10	LUG, terminal; 2 used
29-82906N01	29-82906N01	TERMINAL, blade fuse; 8 used
15-84576N01	15-84576N01	HOUSING, fuse clip; 4 used

TRN5336A Power Supply Hardware Kit (500 W) PL-8020-B

REFERENCE SYMBOL	MOTOROLA PART NO.	DESCRIPTION
C601	8-82682N01	capacitor, fixed: 20 uF ± 6%; 330 V
C602,603	23-82681N01	64,000 uF + 75-7%; 20 V
C604	23-82681N02	120,000 uF + 75-10%; 20 V
CR601,602	48-82732C09	diode: (see note) silicon
P602	9-83360N01	connector, receptacle: female; 6 contact
L601	25-82686N01	coil: choke; 420 uH
T601	25-82253N01	transformer: power; 500 W; 60 Hz
TB601	31-83576K02	terminal, board: 2-terminals
mechanical parts		
2-10971A17	2-10971A17	NUT, machine; M4 x 0.7 hex; 4 used
2-10971A18	2-10971A18	NUT, machine; M5 x 0.8 hex; 4 used
3-10907A55	3-10907A55	SCREW, machine; M6 x 1 x 25mm; 4 used
3-83497N01	3-83497N01	SCREW, machine; M4 x 0.7 x 25mm; 4 used
3-83497N02	3-83497N02	SCREW, terminal; M5 x 0.8 x 12mm; 6 used
3-83498N04	3-83498N04	SCREW, tapping; M4 x 0.7 x 7mm; 18 used
3-83498N06	3-83498N06	SCREW, tapping; M4 x 0.7 x 16mm; 2 used
3-83678N02	3-83678N02	SCREW, tapping; M3 x 0.5 x 5mm
4-7651	4-7651	LOCKWASHER, #8 internal; 10 used
4-83499N01	4-83499N01	WASHER, insulator; 3 used
4-7658	4-7658	LOCKWASHER, #10 internal; 20 used
5-82904N01	5-82904N01	GROMMET; 4 used
14-83277N01	14-83277N01	INSULATOR, lug; 3 used
14-84088N01	14-84088N01	INSULATOR, cap terminals; 2 used
14-84548A01	14-84548A01	INSULATOR, washer; 2 used
26-82902N01	26-82902N01	HEAT SINK
29-824456	29-824456	LUG, ring tongue; 2 used
29-845081	29-845081	LUG, ring tongue; 2 used
29-82907N02	29-82907N02	TERMINAL, ring
29-82907N03	29-82907N03	TERMINAL, ring; 4 used
29-83113N01	29-83113N01	TERMINAL, right angle; 6 used
29-83137N01	29-83137N01	TERMINAL, splice; 2 used
39-83146N01	39-83146N01	CONTACT, socket
42-85238	42-85238	CLAMP, cable; 2 used
42-10217A02	42-10217A02	STRAP, tie; .091 x 3.62; 16 used
42-35424B03	42-35424B03	STRAP, tie; .094 x 14; 3 used
42-82903N01	42-82903N01	CLAMP, cap; 2"
42-82903N02	42-82903N02	CLAMP, cap; 2 1/2"; 2 used
42-82903N03	42-82903N03	CLAMP, cap; 3"
43-82980N03	43-82980N03	STANDOFF; 4 used
29-824154	29-824154	TERMINAL, ring non-insulated; 4 used
29-82907N01	29-82907N01	TERMINAL, ring; 18-22GA; 2 used

note: For optimum performance, diodes, transistors, and integrated circuits must be ordered by Motorola part numbers.

STANDARD POWER SUPPLY

MODEL TPN1191A

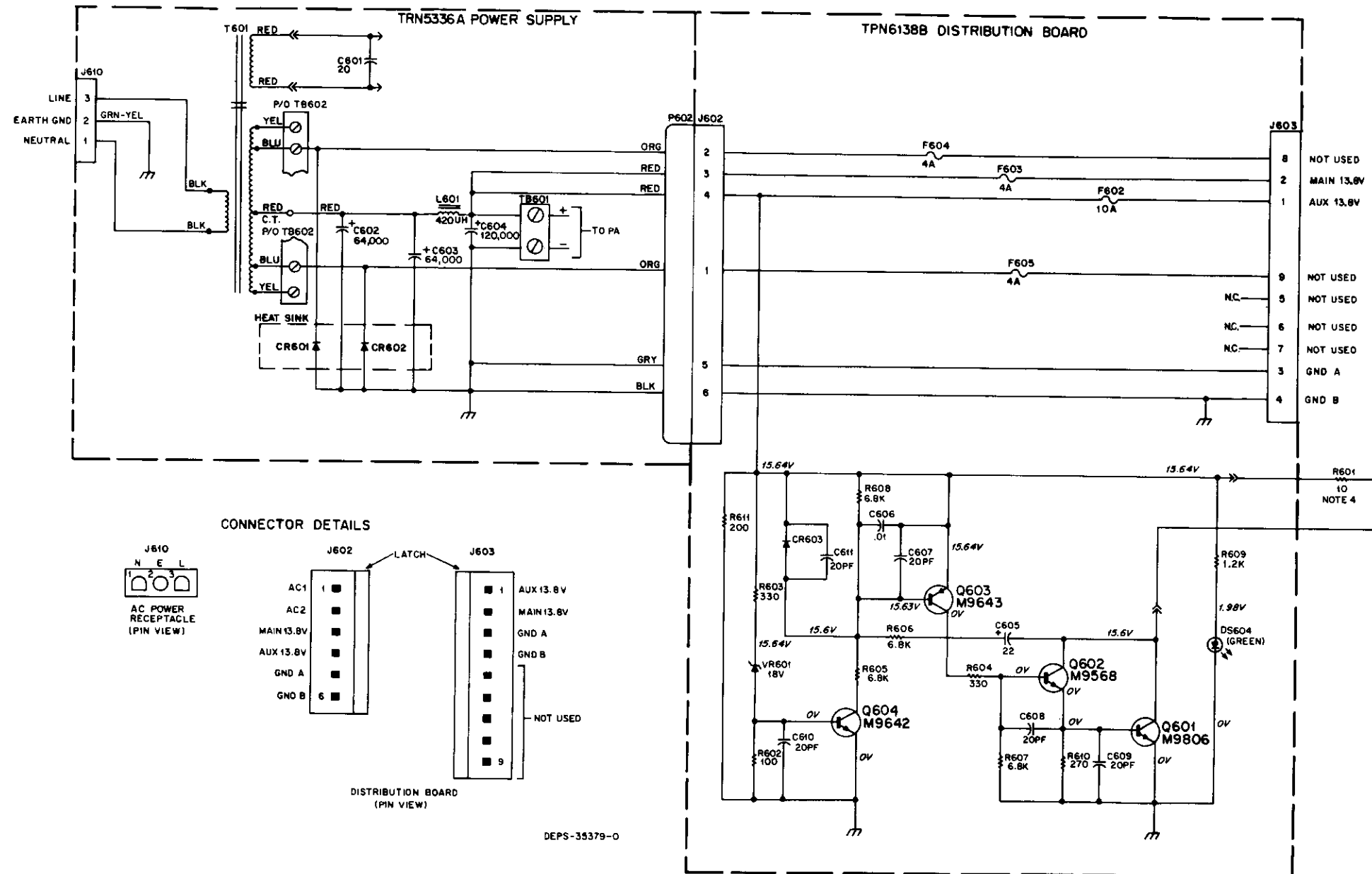

NOTES:

1. Unless otherwise indicated: resistor values are in ohms; capacitor values are in microfarads; and inductor values are in millihenries.
2. Voltages measured with DVM, with 1 megohm or greater input resistance.
3. Circuit conditions: load current = 2A, @ 120 V AC (line in).
4. R601 is mounted on power supply chassis.

TRN5336A Standard Power Supply, and
 TRN6138B Distribution Board
 Schematic Diagram, Circuit Board Details,
 and Parts Lists
 Motorola No. PEPS-34737-C
 (Sheet 2 of 2)
 1/14/83 - V & G

STANDARD POWER SUPPLY

MODEL TPN1191A

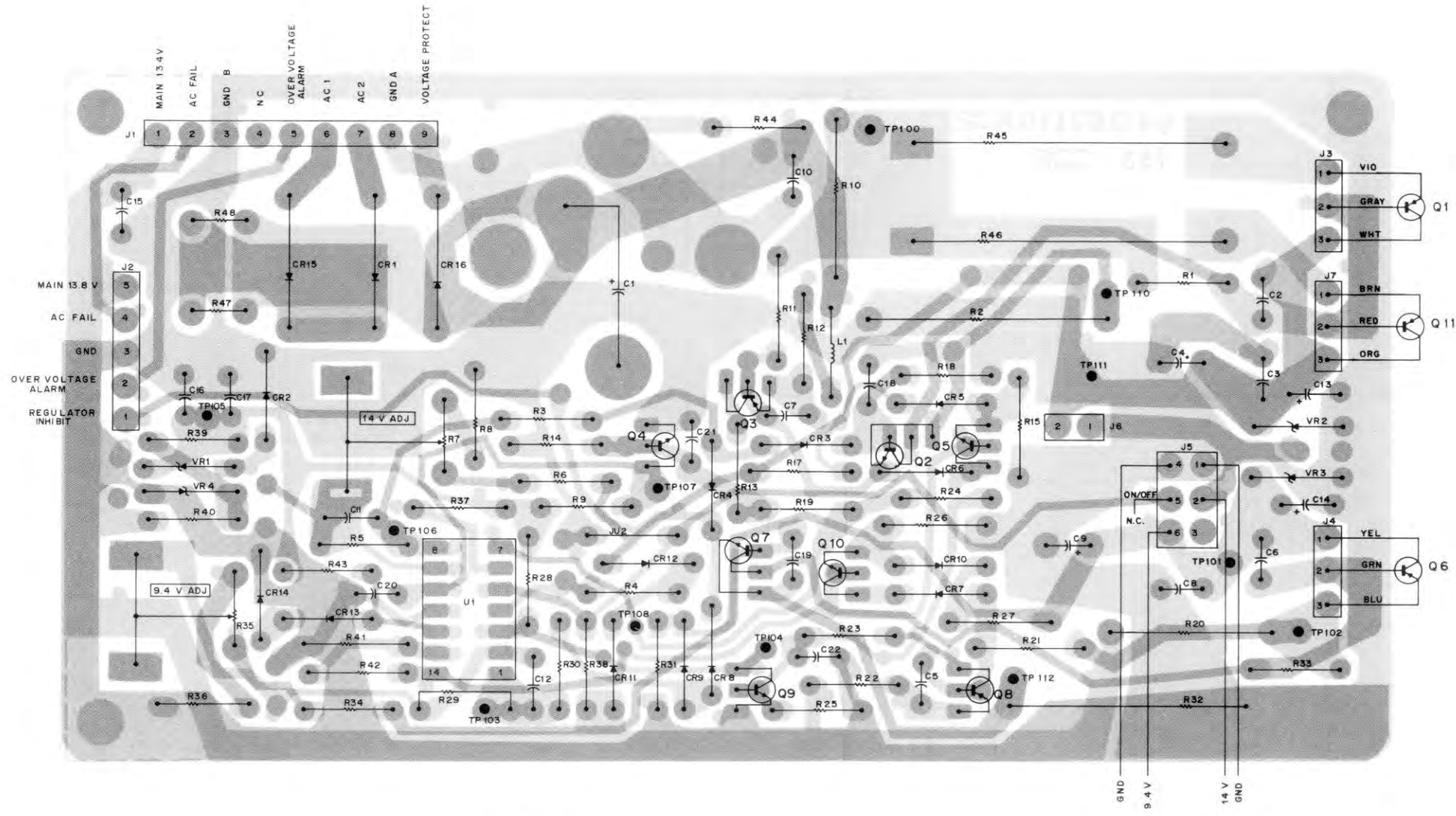

SHOWN FROM COMPONENT SIDE

SOLDER SIDE: BO DEPS-34349-A
 COMPONENT SIDE: BO DEPS-34350-A
 OL DEPS-34351-A

parts list

TRN5119A Auxiliary Regulator Board PL-7945-O

REFERENCE SYMBOL	MOTOROLA PART NO.	DESCRIPTION
C1	23-82394A19	capacitor, fixed: uF: 3600 + 150-10%; 40 V
C2, 3	21-11015B13	.001 ± 10%; 100 V
C4	23-84665F15	330 + 10-50%; 25 V
C5 thru 8	21-11015B13	.001 ± 10%; 100 V
C9	23-84665F15	330 + 10-50%; 25 V
C10	21-11015B13	.001 ± 10%; 100 V
C11, 12	21-82428B21	.01 + 10-30%; 100 V
C13, 14	23-84538G02	4.7 ± 20%; 20 V
C15, 16	21-11015B13	.001 ± 10%; 100 V
C17	21-11022G39	24 pF ± 5%; 50 V
C18, 19	21-11015B13	.001 ± 10%; 100 V
C20	21-11022G39	24 pF ± 5%; 50 V
C21, 22	21-11015B13	.001 ± 10%; 100 V
CR1	48-82525G13	diode: (see note) silicon
CR2 thru 12	48-83654H01	silicon
CR13, 14	48-82392B12	silicon
CR15	48-82525G13	silicon
CR16	48-82525G19	silicon
J1	29-82984N12	connector, receptacle: male; 8-contact
J2	9-83497F08	female; 5-contact
J3	28-82984N02	male; 3-contact
J4	28-82984N03	male; 3-contact
J5	1-80754D88	Assembly connector, consists of: Housing, receptacle; 6-position
J6	15-84953L01	Contact, receptacle; 6 used
J7	39-82977N01	male; 2-contact
J8	28-82984N01	male; 2-contact
J9	28-82984N02	male; 3-contact
JU2	6-11009B23	jumper: "0" ohms
L1	24-83961B01	coil, rf: choke
Q2	48-869633	transistor: (see note) NPN; type M9833
Q3	48-869643	PNP; type M9643
Q4, 5	48-869642	NPN; type M9642
Q7	48-869633	NPN; type M9833
Q8	48-869643	PNP; type M9643
Q9, 10	48-869642	NPN; type M9642
R1	6-11009A49	resistor, fixed: ± 5%; 1/4 W: 1k
R2	17-82177B16	100 ± 10%; 5 W
R3	6-11009A57	2.2k
R4	6-11009A03	12
R5	6-11009A99	120k
R6	6-11009A59	2.7k
R7	18-83083G14	var. 1k
R8	6-11009A58	2.4k
R9	6-11009A69	6.8k
R10	17-82036G24	0.13; 2 W
R11	6-84444A01	332 ± 1%; 1/8 W
R12	6-11009A25	100
R13	6-11009A73	10k
R14	6-11009A57	2.2k
R15	6-10621C81	7.87k ± 1%; 1/8 W
R17	6-10621C79	7.5k ± 1%; 1/8 W
R18	6-11009A61	3.3k
R19	6-11009A73	10k
R20	17-82036G24	0.13; 2 W
R21	6-84444A01	332 ± 1%; 1/8 W
R22	6-11009A25	100
R23, 24	6-11009A73	10k
R25	6-11009A57	2.2k
R26	6-10621C81	7.87k ± 1%; 1/8 W
R27	6-10621C79	7.5k ± 1%; 1/8 W
R28	6-11009A69	6.8k
R29	6-11009A99	120k
R30	6-11009A57	2.2k
R31	6-11009A61	3.3k
R32	17-82177B16	100 ± 10%; 5 W
R33	6-11009A33	220
R34	6-11009A53	1.5k
R35	18-83083G14	var. 1k
R36	6-11009A63	3.9k
R37, 38	6-11009A89	47k
R39	6-11009A53	1.5k
R40	6-11009A39	390
R41	6-84444A09	2.43k ± 1%
R42	6-10621D05	13.7k ± 1%; 1/8 W
R43, 44	6-11009A73	10k
R45, 46	17-82177B64	2.6; 10 W
R47, 48	17-82177B12	0.7 ± 10%; 5 W

REFERENCE SYMBOL	MOTOROLA PART NO.	DESCRIPTION
U1	51-83629M08	integrated circuit: (see note) quad op amp
VR1	48-82256C61	voltage regulator: (see note) Zener, 5.8 V
VR2	48-82256C63	Zener, 17 V
VR3	48-82256C13	Zener, 14 V
VR4	48-82256C11	Zener, 10 V

note: For optimum performance, diodes, transistors and integrated circuits must be ordered by Motorola part numbers.

STANDARD POWER SUPPLY
MODEL TPN1191A

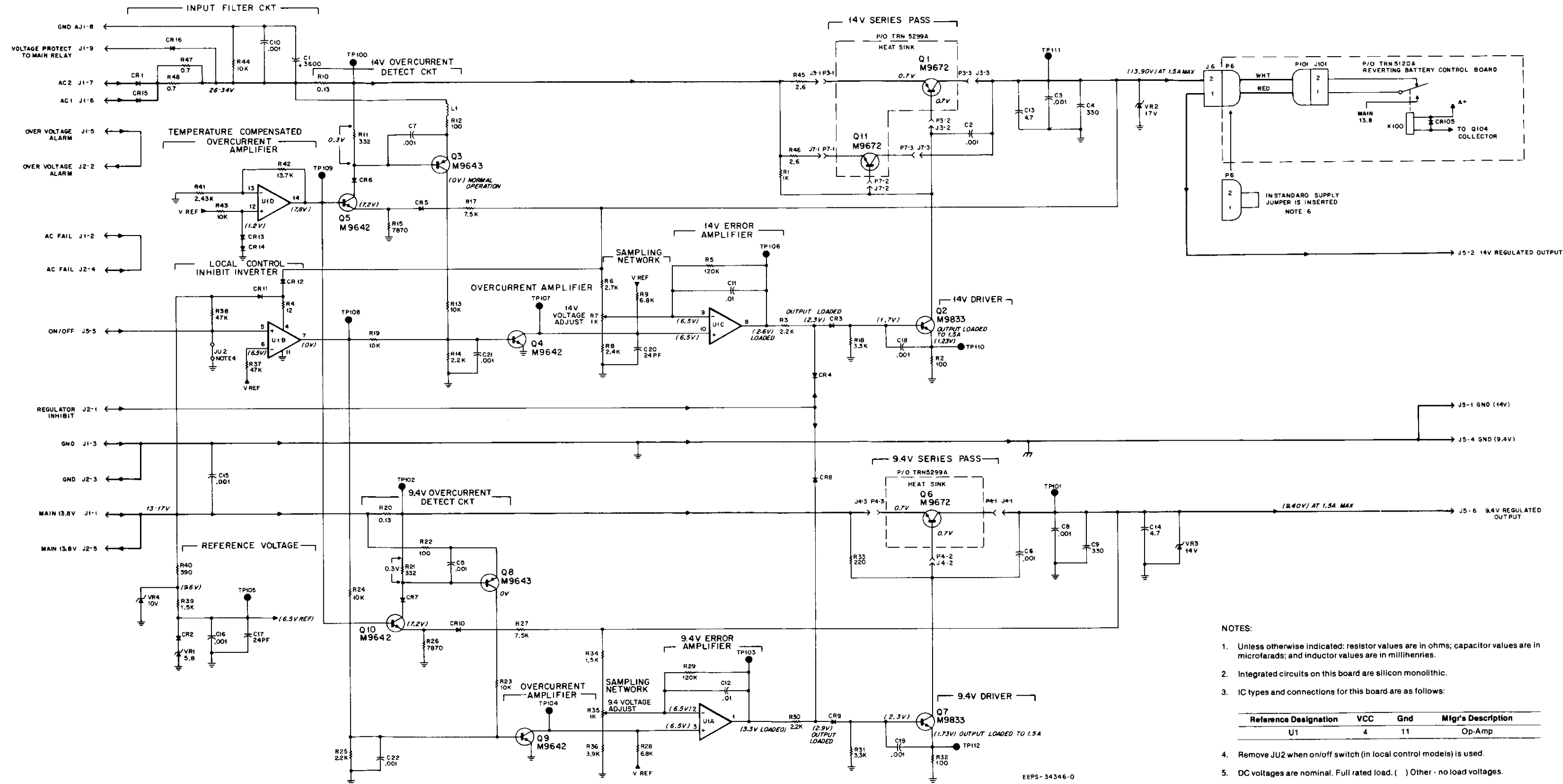

- NOTES:
- Unless otherwise indicated, resistor values are in ohms; capacitor values are in microfarads; and inductor values are in millihenries.
 - Integrated circuits on this board are silicon monolithic.
 - IC types and connections for this board are as follows:
- | Reference Designation | VCC | Gnd | Mfg's Description |
|-----------------------|-----|-----|-------------------|
| U1 | 4 | 11 | Op-Amp |
- Remove JU2 when on/off switch (in local control models) is used.
 - DC voltages are nominal. Full rated load. () Other - no load voltages.
 - For non-battery supply (standard supply) insert connector jumper.

TRN5119A Auxiliary Regulator Board
Schematic Diagram, Circuit Board Detail,
and Parts List
Motorola No. PEPS-38130-O
(Sheet 2 of 2)
10/31/83 - V & G

STANDARD POWER SUPPLY

STANDARD POWER SUPPLY

MODEL TPN1191A

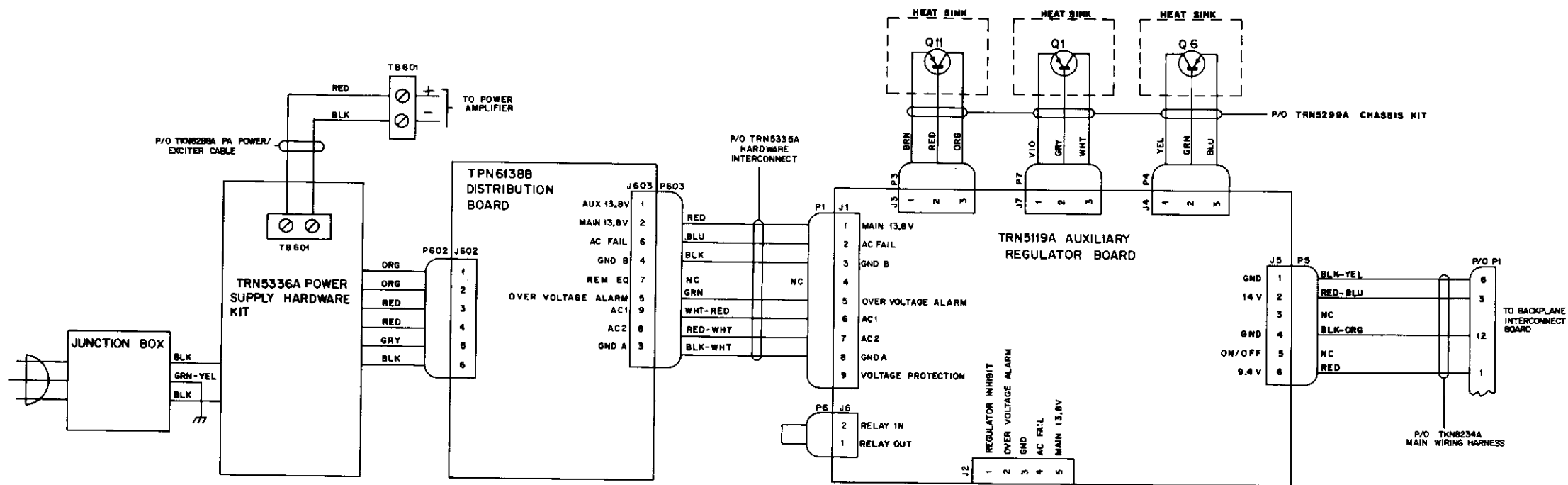

DEPS-34365-A

TPN1191A Standard Power Supply
Cable Interconnect Wiring Diagram
Motorola No. DEPS-34365-A

10/31/83 - V & G



MOTOROLA INC.

Communications
Sector

OPTION C28AN BATTERY CHARGER POWER SUPPLY

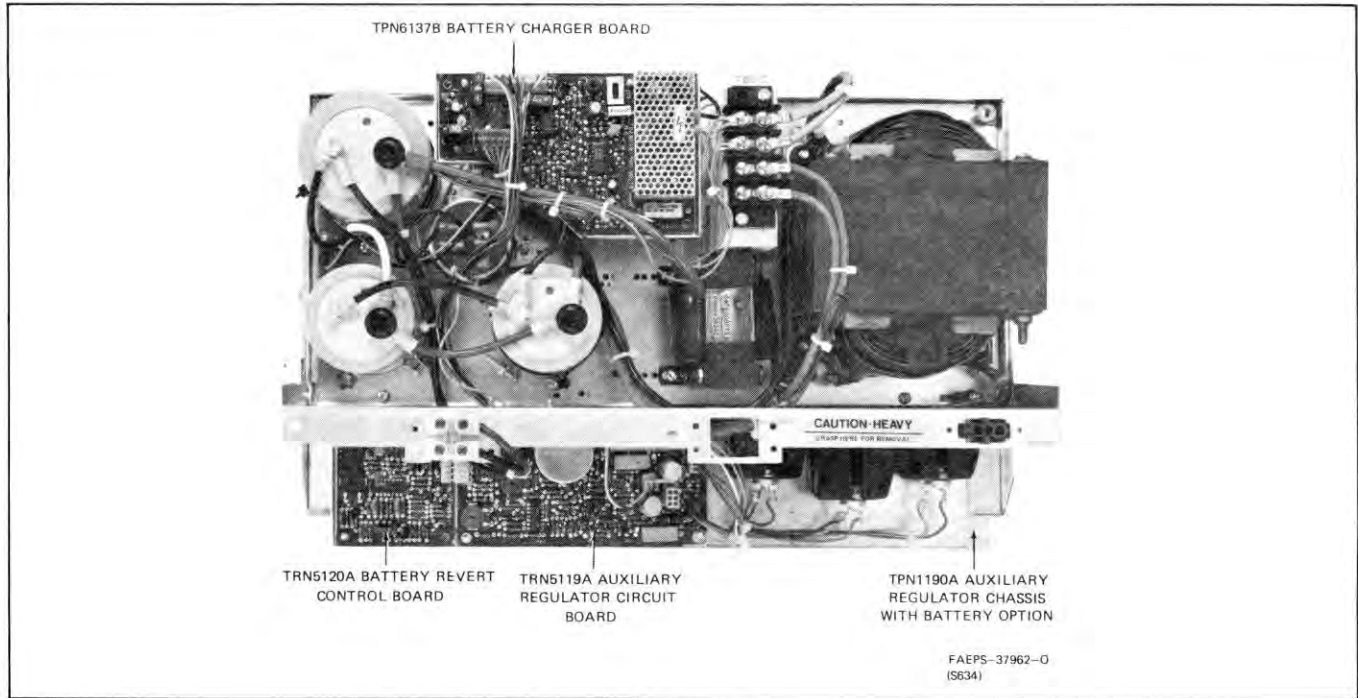

Figure 1. Model TPN1192A Battery Charger Power Supply

1. DESCRIPTION

1.1 A C28AN Battery Charger Power Supply is a factory installed accessory that is available for all models of Motorola base and repeater stations. Refer to Table 1 for the model complement of Option C28AN and a model breakdown of Model TPN1192A Battery Charger Power Supply.

1.2 The C28AN option permits the station to operate from 120 volt, 60 Hz ac power normally, but provides continued operation from 12-volt batteries (emergency power) if the ac power should fail. When ac power is restored, the power supply also operates as a battery charger to recharge the batteries. Refer to Table 2 for performance specifications.

1.3 The C28AN option includes a battery protection and alarm package that is factory installed, to improve emergency power backup by providing an audible

alarm whenever the station is operating on batteries. The battery protection and alarm generates an audible alarm tone which "beeps" to indicate that the station is operating on emergency power. This tone burst, with a frequency of about 1400 Hz, is approximately 1/4 second long and repeats at 2-1/2 second intervals. On remote control stations, or repeater stations with wire line control, the alarm tone is injected into the audio line and is heard at the console (except when transmitting). On repeater stations, without wire line control, the tone is transmitted whenever the transmitter is keyed, so that anyone receiving signals from this station will know that it is operating on emergency power.

1.4 There are two ways of using the battery protection and alarm. One way is to shut off the low current regulators when the batteries have discharged to a certain level. This connection would protect the battery

BATTERY CHARGER POWER SUPPLY

from damage due to excessive discharge, it also keeps the station from operating from voltages outside normal range.

1.5 The second method is to keep the regulators running continuously during emergency use. When connected in this manner, the tone burst changes to a continuous tone of about 1400 Hz when the batteries have discharged below a defined level.

1.6 The C28AN option also includes a 2nd continuous alarm tone which informs the user of a failure in the float charger which may result in battery damage. The tone is a continuous 1400 Hz tone. This overvoltage alarm will disconnect the transformer from the station and allow battery operation in the event of a controller failure.

1.7 The power supply/battery charger is of the controlled ferroresonant design. The supply provides high current A + at 14.25 V dc, A + at 13.90 V dc, and 9.4 V dc to power any continuous or intermittent duty radio. Current limiting, short circuit and over-voltage protection are also provided.

1.8 The batteries used as the emergency source can be of either the nickel-cadmium or lead-acid type. An automotive type battery is not recommended as an emergency dc supply.

1.9 A two-position switch on the battery charger board determines the charging rate of the bat-

teries. In the FLOAT position, a voltage is supplied to the batteries, sufficient to maintain them in a fully charged state. The EQUALIZE position increases the charging voltage to restore the batteries after emergency use or where the condition of the battery dictates.

Table 1. Model Complement of Option C28AN and Model TPN1192A Battery Charger Power Supply

Kit	Sub-Kit	Description
TKN8295A		Battery Charger Cable
TRN5155A		Battery Cable, External
TPN1192A		Battery Charger Power Supply
TPN6137B		Battery Charger Circuit Board
TRN5153A		Battery Charger Hardware
TRN5336A		Domestic Power Supply Hardware
TRN5362A		Interconnect Hardware
TPN1190A		Auxiliary Chassis with Battery Option
	TRN5119A	Auxiliary Regulator Circuit Board
	TRN5120A	Battery Revert Control Circuit Board
	TRN5209A	Hardware Kit
	TRN5299A	Chassis Kit

2. THEORY OF OPERATION

(Refer to attached diagram for circuit details.)

2.1 TRN5336A STANDARD POWER SUPPLY

The TRN5336A Standard Power Supply performs the conversion of ac line power to dc radio power. The

Table 2. Performance Specifications

Operating Temperature	-30° to +80°
Input Voltage	96 V to 132 V ac, 60 Hz

HIGH CURRENT OUTPUT

Output Voltage	13.1 V Lead Acid 14.25 V NiCad and also if any battery is not connected 14.1 V Lead Acid Equalize 15.25 V NiCad Equalize
Output Current	30.4A at 14.1 V (see graph for other points).
Load Transient	Shall not drop below 11.0 V for a 0 to 30.4A load with the 9.5 V regulator loaded to 1.5A.

9.4 V OUTPUT

Output Voltage	9.4 V dc nom. (9.1-9.7 adjustable)
Output Ripple	Less than 5 mV rms
Line Regulation	Shall not change more than 50 mV over input range.
Load Regulation	Shall not change more than 0.150 V over load.
Output Current	1.1A at 80°C

14 V OUTPUT

Output Voltage	13.9 V nom. (13.5-14.1 adjustable)
Output Ripple	Less than 5 mV rms
Line Regulation	Shall not change more than 25 mV over input voltage
Load Regulation	Shall not change more than 0.255 V over load.
Output Temperature Coefficient	1.5 mV/°C typical
Output Current	1.16A at +80°C

ALARM TONE OUTPUT

Alarm Tone Frequency	1400 Hz ± 200 Hz @ 25°C
Alarm Rep Rate	1.6 sec. to 4 sec.
Alarm Tone Duty Cycle	10% typical
Tone Output Level	Adjustable from 0 V to 1 V p-p into a 600 ohm load
Low Voltage Dropout Level	Adjustable 10.5 V nominal

SPECIFICATIONS SUBJECT TO CHANGE WITHOUT NOTICE

supply consists of rectification and filtering. The secondary voltage of transformer T601 is rectified by CR601 and CR602. Ground connection for the diodes is provided through the heat sink to chassis. Output filtering is provided by the network of C602, C603, L601, and C604.

2.2 TRN6137B BATTERY CHARGER BOARD

Line and load regulation is controlled by the TRN6137B Battery Charger Board. Refer to schematic diagram attached at the end of this section. Regulation is accomplished by controlling the saturation of ferroresonant transformer T601 via a control inductor, L650. This inductor is switched across the resonant winding on the transformer as the output voltage reaches a preset level. Potentiometer R662 (VOLT. ADJ.) permits output voltage adjustment. Switching and timing circuitry for the control inductor is described in the following paragraphs.

2.2.1 Clock Generator

Q655 and Q650 derive a line frequency related clocking signal for timing and triggering purposes.

2.2.2 10 Volt Reference

Zener VR650 establishes a 10 volt reference used by the activity detector, stabilizer, and control voltage generator circuits.

2.2.3 Monostable Switch

U650D converts the clock signal into a monostable pulse which drives the ramp generator.

2.2.4 Ramp Generator

Q651 generates a ramp voltage in conjunction with C653.

2.2.5 Control Voltage Generator

U650A compares a reference voltage with the output voltage and generates a control voltage with gain to the pulse width modulator.

2.2.6 Pulse Width Modulator

U650C compares the control voltage with the ramp and generates a pulse whose width is determined by how early in the ramp cycle the control voltage equals the ramp voltage.

2.2.7 Stabilizer

U650B keeps the monostable switch (U650D) from changing state for approximately 1/2 cycle to eliminate triggering errors due to line and load transients.

2.2.8 Power Switch

SCR Q656 and TRIAC Q657 work together to switch a control inductance in and out of the resonant winding on the power transformer. The diode bridge between the SCR and TRIAC allows the TRIAC to be triggered every half cycle.

2.2.9 Overvoltage Protection

Overvoltage comparator U651A and U651B compares the voltage appearing at the arm of R662 with a fixed voltage developed across a voltage divider consisting of R678, R683, and R655. Any increase or decrease in A+ voltage is reflected at the arm of R662 and applied to U651A-3. If the A+ voltage at U651A-3 rises above the fixed voltage applied to U651A-2, the output at U651A-1 goes high. This action begins charging capacitor C659. If the A+ voltage remains high, C659 will charge to a level above the reference applied to U651B-5. This causes U651B-7 to go high, which in turn, turns on Q660, Q654, and Q653. Once Q660 and Q664 are turned on, the overvoltage protection relay K650 is energized which removes the transformer secondary center tap return path. Relay K650 will now remain energized until ac power and/or battery power is disconnected from the station. Similarly, Q653 will remain turned on to provide the overvoltage alarm output at J603-5 until ac power and/or battery power is disconnected. Zener diode VR651 provides additional protection by forcing the overvoltage circuits to energize in the event that overvoltage sensing through R662 fails.

2.2.10 Line Fail Sense

Q658 and Q659 generate a "line fail" signal when a loss of clock signal is detected. Q658 senses failure at the ac line and Q659 generates the output signal AC FAIL.

2.2.11 Power Up Reset

Q662 and Q661 use the line fail sense signal from Q658 to generate a power up reset input to the pulse width modulator, U650C, each time power is turned on. The power up reset signal is applied to the control voltage input (U650C-9) of the pulse width modulator and enables quick power up.

2.3 TRN5119A AUXILIARY REGULATOR BOARD

The TRN5119A Auxiliary Regulator Board provides regulated 9.4 V and 14 V for the radio. The board circuitry consists of a reference voltage, 9.4 V and 14 V regulators, a temperature-compensated overcurrent amplifier, and a local control inhibit inverter.

2.3.1 Reference Voltage

The operational amplifiers on the circuit board require a stable reference voltage. This reference voltage is produced in two stages of circuitry. The first stage consists of VR4 and R40 which are connected to J1-1 and main 13.8 V. Diode VR4 regulates at 9.6 V. The second stage, which operates from this 9.6 V, is temperature compensated and consists of VR1, CR2, and R39. The resultant 6.5 V reference is fed to each of the operational amplifiers.

2.3.2 9.4 V Regulator

2.3.2.1 The 9.4 V regulator is a series pass type circuit using a PNP transistor (Q6). A PNP type transistor can provide voltage regulation with as little as 0.7 V differential between collector and emitter. This means that the input voltage can go as low as 10.4 V, and the circuitry will still maintain voltage regulation. The voltage regulator circuitry provides output voltage adjustment, correction for changes of input voltage and load requirements, and over-current protection.

2.3.2.2 The 9.4 V regulated output voltage (J5-6) is set by the 9.4 V VOLTAGE ADJUST potentiometer, R35. The voltage from R35 goes to U1A-2 and is compared to U1A-3, the reference voltage input. The differential voltage appears at U1A-1. For example, if U1A-2 becomes less positive, the output of U1A-1 becomes more positive, causing Q7 to conduct harder. Increased collector current at Q7 causes increased base-emitter current at Q6. As a result, Q6 conducts harder, with a resultant higher (more positive) regulated output voltage at J5-6.

2.3.2.3 The circuitry described in the previous paragraph is a negative feedback loop. It maintains a constant output voltage for changes in load or input voltage. The feedback loop has typically 50 dB of gain at dc to give a load/line regulation of ± 0.1 V dc maximum from no load to full load. As an example, for an increase in load current, the regulator output voltage would normally decrease. The reduced output voltage is sensed at U1A-2, which is now less positive than U1A-3, the reference voltage. U1A-1 goes more positive and drives Q7 into further conduction. An increase in collector current of Q7 causes increased conduction of Q6. The regulated output voltage returns to normal. A decrease in load current causes the opposite action.

2.3.2.4 The overcurrent protection circuitry is of the current foldback type. As the load increases beyond the knee, the output voltage and current decrease simultaneously to a final short circuit current of 0.77 amp maximum. The current is sensed across R20. When this voltage exceeds about 0.3 volt (representing a load current of approximately 2.3 amps), Q8 is forward biased and starts to conduct. When Q8 conducts, its collector goes positive, turning on Q9. The conduction of Q9 increases the voltage drop across R28 causing the

voltage at U1A-3 to drop. The drop in voltage of U1A-3 causes a corresponding drop in voltage of U1A-1. This action causes Q7 and Q6 to conduct less current. As a result, the output voltage (9.4 V regulated) decreases. If the output current continues to increase, Q8 and Q9 conduct harder which results in a further reduction in voltage through Q6. This action continues until the output voltage drops to approximately 6.5 V. At this point, CR10 becomes forward biased increasing the current through Q10. This action causes Q8 to conduct harder which, through Q9, U1A, and Q7, reduces the current through Q6. Notice, therefore, a short circuit at the output of Q6 actually results in less dissipation through Q6 than full normal operating load. This prevents damage to Q6 due to overcurrent conditions.

2.3.3 14 V Regulator

2.3.3.1 The 14 V regulator is a series pass type circuit using PNP transistors (Q1 and Q11). A PNP type transistor can provide voltage regulation with as little as 0.7 V differential between collector and emitter. This means that the input voltage can go as low as 14.7 V, and the circuitry will still maintain voltage regulation. The voltage regulator circuitry provides output voltage adjustment, correction for changes of input voltage and load current, and overcurrent protection.

2.3.3.2 The input filter circuitry provides power to the 14 V regulator. CR1 and CR15 rectify ac to dc (26-34 V). Resistors R47 and R48 limit the surge and reduce the ripple current across filter capacitor C1.

2.3.3.3 The 14 V regulated (J5-2) output is set by the 14 V VOLTAGE ADJUST potentiometer, R7. The voltage from R7 goes to U1C-9 and is compared to U1C-10, the reference voltage input. The differential voltage appears at U1C-8. For example, if U1C-9 becomes less positive, the output at U1C-8 becomes more positive, causing Q2 to conduct harder. Increased collector current at Q2 causes increased base-emitter current at Q1 and Q11. As a result Q1 and Q11 conduct harder, with a resultant higher (more positive) regulated output voltage at J5-2.

2.3.3.4 The circuitry described in the previous paragraph is a negative feedback loop. It maintains a constant output voltage for changes in load or input voltages. The feedback loop has typically 50 dB of gain at dc to give a load/line regulation of ± 0.1 V dc maximum from no load to full load. As an example, for an increase in load current, the regulator output voltage would normally decrease. The reduced output voltage is sensed at U1C-9, which is now less positive than U1C-10, reference voltage input. U1C-8 goes more positive and drives Q2 into further conduction. An increase in collector current of Q2 causes increased conduction of Q1 and Q11. The regulator output returns to normal. A decrease in load current causes the opposite action.

2.3.3.5 The overcurrent protection circuitry is of the current foldback type. As the load increases beyond the knee, the output voltage and current decrease simultaneously to a final short circuit current of 0.77 ampere maximum. The current is sensed across R10. When this voltage exceeds about 0.3 volts (representing a load current of about 2.3 amperes), Q3 is forward biased and starts to conduct. Its collector goes positive, causing Q4 to conduct thru R13 and R14. Q4 conducting lowers the voltage at R9 (V REF). As the voltage on U1C-10 lowers, it causes the voltage on U1C-8 to go lower, forcing Q2, Q1, and Q11 to conduct less. As a result, the output voltage (14 V regulated) decreases. As output current increases, Q3 and Q4 conduct harder, resulting in higher Q1 and Q11 impedance. This action continues until the output voltage decreases to about 6.5 V. At this point, CR5 becomes forward biased, and the emitter current of Q5 increases. This results in an increased voltage across R11. This will forward bias Q3 harder. As a result less output current can be drawn under a short circuit condition. This is desirable because the power dissipated in Q1 and Q11 is now reduced.

2.3.4 Temperature Compensated Overcurrent Amplifier

The temperature compensated overcurrent amplifier (U1D) compensates the knee of the 9.4 V and 14 V overcurrent detect circuits (Q3 and Q8). Compensation allows operation from -30°C to $+80^{\circ}\text{C}$ without degradation in available output current. Compensation begins at diodes CR13 and CR14. These diodes are temperature sensitive, having a voltage decrease of about 2 mV for an increase of each degree centigrade. A temperature increase makes U1D-14 less positive. Both Q5 and Q10 reduce collector current with a reduction in voltage drop across R11 and R21. The reduced voltage across the bias resistors counteracts the effects of high ambient temperatures on Q3 and Q8.

2.3.5 Local Control Inhibit Inverter

The local control inhibit inverter (U1B) is used to turn off the 9.4 V and 14 V voltage regulators externally for local control operation. When used, jumper JU2 is removed, and J5-5 is connected to ground thru the normally closed contacts of a switch. Opening the switch contacts causes U1B-7 to go high. Both Q4 and Q7 are driven into saturation. U1C-8 and U1A-1 are pulled low which cuts off Q6, Q1, and Q11.

2.3.6 Overvoltage Protection Relay

On battery charging supplies, in the event of an overvoltage alarm, relay K650 will pull in to prevent overcharging of the battery system. With the wiper of K650 tied to the transformer center tap, the relay "pull in" will disconnect the high current A+ from the filter section. In addition to disconnecting the filter section,

K650 opens the fuses F604 and F605 which feed the auxiliary regulator. By tying the positive terminal of C1 in the AUX regulator (via CR16) to the normally open contact of K650, the transformer windings are presented a relatively low impedance path through F604 and F605 when K650 energizes.

2.4 TRN5120A BATTERY REVERT CONTROL BOARD

The TRN5120A Battery Revert Control Board is a supervisory control board designed to regulate the transition from ac main power to battery back-up operation. To accomplish this the board: 1) switches out the 14 V regulator in the event of a power failure or controller failure, 2) monitors battery condition to prevent overdischarge, and 3) generates alarm tones to indicate ac power failures or controller failures.

2.4.1 Regulator Output Switching

2.4.1.1 In conditions where battery operation is required (i.e., ac power failure or controller failure) it is necessary to switch the low current A+ (regulated 14 V) load from the regulator output to the battery due to the high losses in the 14 V regulator. By using a relay to switch the output, the battery revert control board achieves a reduced IR loss between the battery and the load, which serves to lengthen the amount of time the user has to run his station.

2.4.1.2 The relay (K100) is controlled by the AC Fail and 0 V alarm signals which are generated in the ferroresonant controller. These signals are applied to the base of Q101 (AC Fail directly, and 0 V alarm through CR107) and are normally high. When these signals are high, the collector of Q101 saturates, preventing the relay driver (Q104) from turning on the relay.

2.4.2 Low Battery Voltage Dropout

2.4.2.1 When either AC Fail or 0 V alarm are low, a voltage comparator monitors the battery voltage to determine the battery condition. When the voltage drops below a certain voltage, the comparator shuts off the relay (K100), inhibits the low current regulators, and forces the alarm tone generator to produce a continuous tone.

2.4.2.2 The comparator consists of a Norton mode op amp (U100-C) biased to function as an inverting Schmitt trigger with an adjustable trigger level (R129) and a reset/inhibit input (via CR111). Under normal operation (AC Fail and 0 V alarm high), the comparator output is held low since Q101 is saturated, Q102 is shut off, and the current applied to U100C-8 through R106, CR111, and R111 is greater than the current applied to U100C-13 through R112. When AC Fail or 0 V alarm goes low, Q101 shuts off and Q102 saturates. This action back biases CR111 preventing any

current flow through R111 thereby allowing the comparator to function. Once the A + voltage drops below a certain voltage (manually set using R129) the comparator output goes high, causing Q103 and Q105 to saturate. The collector of Q103 is tied to the base of Q104, which drives the relay. Once Q103 saturates, no current flows in the base of Q104, shutting off K100. Q105 is tied to Q2 and Q7 (via CR4 and CR8) of the regulator. When Q105 saturates, the base drive of Q2 and Q7 is drawn off, causing the pass elements in the regulators to shut off. The comparator output is also fed into the pulse inhibit input of the pulse generator which causes the pulse generator to inhibit when the comparator output is high.

2.4.3 Alert Tone Generation

2.4.3.1 The battery revert control board is designed to provide two alert signals. The first is a pulsed 1400 Hz tone which indicates the loss of ac power. The second is a continuous 1400 Hz tone which indicates conditions which may result in battery damage.

2.4.3.2 By noting the sequence in which the continuous tone appears, the user can determine the nature of the problem. When a pulsed tone (indicating loss of ac power) is followed by a continuous tone, the user can assume that the batteries are fully discharged, and station operation may not last much longer. A continuous tone which suddenly appears, indicates that failure of the power supply has occurred and that battery operation has commenced.

2.4.3.3 The alert tones are generated by a phase shift oscillator whose output is gated by a pulse generator. This pulse generator is then controlled by a combination of AC Fail, 0 V alarm and the voltage comparator output.

2.4.3.4 The tone generator consists of a Norton type op amp (U100-B) with a phase shift feedback path to cause oscillation. A tone inhibit function has been added by tying the output of Q102 to the inverting input (via R134). When Q102 is high (i.e. AC Fail and 0 V alarm are high), enough current is forced into pin 6 of U100-C to cause the oscillator output to clamp to ground. Once Q102 goes low, the oscillator output dc voltage becomes 1/2 the output of the pulse generator which is fed into the non-inverting input of U100-D.

2.4.3.5 The pulse generator also consists of a Norton type op amp biased as an inverting Schmitt trigger (U100-D) with an RC network added to provide asynchronous switching. Under most conditions, the pulse generator is free running, however when the 0 V alarm goes low or the low voltage comparator output goes high the pulse generator is inhibited, and its output is forced high. The inhibit function is accomplished by applying either the output of U100-C (the low voltage comparator) or U100-A (a simple inverter which inverts 0 V alarm) to the non-inverting input of U100-D which forces the output high.

2.4.3.6 The tone generator output is fed via R126 and JU102 to R128 which allows the level to be adjusted. By removing JU102, 20 dB of attenuation can be obtained when R128 is at mid setting.

3. BATTERY CONNECTION AND INSTALLATION

3.1 POWER SUPPLY

3.1.1 Installation of the station with this option is standard except for the connection of the 12-volt battery (10 cells nickel-cadmium, 6 cells lead-acid).

3.1.2 Locate the battery in a secure place, and as close to the station as possible. The cable length must be kept as short as practical, because of the voltage drop in the battery cable. A substantial voltage drop can be developed across this low resistance due to the high currents drawn from the battery while transmitting.

3.1.3 Select a battery location that has an unobstructed air circulation, preferably a cool dry place with ample width aisles to permit easy access to all cells for installation, taking readings, adding water and cleaning. The battery must not be placed near radiators, boilers, or other heat-producing devices.

3.1.4 Capacity of a battery should be carefully determined before its purchase. Factors that influence the capacity are the busy hour load, the protection time desired, the final cell voltage limit and the minimum operating temperatures. For more information contact your Motorola Area Systems Engineer.

3.1.5 Connection of the battery terminals made during installation is extremely important to its service life. If connections are carefully made with clean, acid-free surfaces and kept tight by periodic checking, they will give trouble-free service over the life of the battery.

CAUTION

Do not attach batteries before setting the float voltage.

3.1.6 Adjustment of the float voltage of the power supply is required at the time the battery is installed. The float voltage is the A + output voltage of the power supply which will keep a battery fully charged when connected across the A + output terminals. The float voltage adjustment varies with the type of battery being installed and with the ambient temperature. Refer to paragraph 4, Level Adjustments, and to the battery manufacturer's literature for adjustment of the float voltage.

3.1.7 Give the battery a freshening or boost charge when it is received. Do this in accordance with the manufacturer's instructions.

3.1.8 Connect the battery cable from the junction box to the battery as follows:

Step 1. Remove fuse F610 from the battery cable to prevent accidental short circuiting during installation.

CAUTION

Observe proper polarity on battery connections.

Step 2. Connect the battery cable plug (P605) to J605 on the junction box, and route the battery cable to the battery connection points.

Step 3. Connect the red wire of the battery cable to the position (+) terminal of the battery.

Step 4. Connect the black wire of the battery cable to the negative (-) terminal of the battery.

Step 5. Check to assure proper polarity of the cable leads, and then reinstall fuse F6501, removed in Step 1.

3.1.9 If power is to be removed from the station for any reason after the initial installation, the most convenient method is to remove the in-line fuse (F601) from the battery cable.

3.2 BATTERY PROTECTION AND ALARM

3.2.1 The C28 option, as shipped from the factory, is wired to include the low voltage regulator dropout for battery protection. If it is desired to have the low voltage detect circuit to cause a continuous tone alarm rather than shut-off the regulators, cut jumper JU101 on the battery revert control board.

3.2.2 When ordered with the C28 option, the rf control chassis backplane will be jumpered to provide the alert tone in the phone line for base station operation, or to provide the alert tone in the exciter for repeater station operation. Refer to the following for jumper details.

- Standard Backplane
 - JU6 — IN
 - JU7 — OUT Tone in phone line
- Optionable Backplane
 - JU13 — IN
 - JU14 — OUT Base Station Operation
 - JU13 — OUT Repeater Station Operation
 - JU14 — IN

4. LEVEL ADJUSTMENTS

4.1 A+ VOLTAGE ADJUSTMENT

The A+ output is factory adjusted for nickel-cadmium batteries at 14.25 volts. If adjustment is

necessary, set output voltage control, R662, in the station power supply for the desired float voltage as follows:

Step 1. Disconnect batteries and replace F602 if missing.

Step 2. Connect a dc voltmeter with 3% accuracy (or better) between terminals TB601+ and TB601- on the power supply. Allow the power supply to warm up for at least 10 minutes.

Step 3. Set the VOLT. ADJ. control R662 to provide a charging voltage: (a) as specified by the battery manufacturer; (b) of 14.25 volts if batteries are not to be connected at this time; (c) of 14.25 volts for nickel-cadmium batteries, or; (d) of 13.1 volts for lead-acid batteries.

CAUTION

When operating the battery charging power supply without batteries, F602 must be present. F602 should be removed when batteries are present and attached to reduce battery drain via load resistor R140 under ac fail conditions.

4.2 REGULATED OUTPUT VOLTAGE ADJUSTMENT

The regulated output voltages can be adjusted with the auxiliary regulator board in the radio or on the service bench. If adjusted on the test bench, the regulator must be supplied 14 V at J1-1 and +28 V at J1-6 or J1-7. The outputs must be loaded to 1.1 ampere each.

Step 1. Measure the regulated output voltages at TP101 (9.4 V) and TP111 (14 V).

Step 2. Set R35 for 9.4 V \pm 0.1 V.

Step 3. Set R7 for 13.9 V \pm 0.1 V.

4. LEVEL ADJUSTMENTS

4.1 A+ VOLTAGE ADJUSTMENT

The A+ output is factory adjusted for nickel-cadmium batteries at 14.25 volts. If adjustment is necessary, set output voltage control, R662, in the station power supply for the desired float voltage as follows:

Step 1. Disconnect batteries and replace F602 if missing.

Step 2. Connect a dc voltmeter with 3% accuracy (or better) between terminals TB601+ and TB601- on the power supply. Allow the power supply to warm up for at least 10 minutes.

Step 3. Set the VOLT. ADJ. control R662 to provide a charging voltage: (a) as specified by the battery manufacturer; (b) of 14.25 volts if batteries are not to be connected at this time; (c) of 14.25 volts for nickel-cadmium batteries, or; (d) of 13.1 volts for lead-acid batteries.

CAUTION

When operating the battery charging power supply without batteries, F602 must be present. F602 should be removed when batteries are present and attached to reduce battery drain via load resistor R140 under ac fail conditions.

4.2 REGULATED OUTPUT VOLTAGE ADJUSTMENT

The regulated output voltages can be adjusted with the auxiliary regulator board in the radio or on the service bench. If adjusted on the test bench, the regulator must be supplied 14 V at J1-1 and +28 V at J1-6 or J1-7. The outputs must be loaded to 1.1 ampere each.

Step 1. Measure the regulated output voltages at TP101 (9.4 V) and TP111 (14 V).

Step 2. Set R35 for $9.4\text{ V} \pm 0.1\text{ V}$.

Step 3. Set R7 for $13.9\text{ V} \pm 0.1\text{ V}$.

4.3 ALARM TONE LEVEL ADJUSTMENT

In remote control stations, and in repeaters with wire line control, the "tone level" control (R128) on the battery revert control board is factory preset to provide a level -20 dB below the set level on the audio control line. In "repeater only" stations, this control is set for a deviation of $\pm 0.5\text{ kHz}$.

The tone level control may be reset to suit the needs of a particular installation by the following procedure.

Step 1. Disconnect the station from the ac power line and allow it to operate on its battery. (This should turn on the alarm tone oscillator.)

Step 2. Set the volume control at a normal comfortable operating level with a received signal.

Step 3. Rotate TONE LEVEL ADJ control R128 until the alarm tone is clearly discernible, but not loud enough to effect the intelligibility of the audio signals on the line. The tone can be turned on continuously by grounding the positive lead of C103.

4.4 LOW-VOLTAGE DETECTOR ADJUSTMENT

Dropout voltage control R129 is factory preset, but may need resetting if any components in the low-voltage detector or associated circuits have been replaced. If it is necessary to readjust the low-voltage detector control, use the following procedure.

Step 1. Disconnect ac and battery power from the station.

Step 2. Connect the output of a variable dc power supply (such as the Motorola R1011A) to TB601 in the power supply. Set the supply to 13.1 V before connecting.

Step 3. Preset low-voltage control R129 to the fully counterclockwise position.

Step 4. Set the output of the variable power supply at 10.5 V.

Step 5. Rotate dropout voltage control R129 clockwise until K100 de-energizes. Read the power supply output voltage just before the point of dropout.

Step 6. Check the relay operation by increasing the supply voltage until the relay pulls in and then reducing it until the relay drops out. Read the supply voltage at the point just before dropout. The relay should drop out when the supply voltage is between 10.0 and 10.8 volts.

Step 7. If the measured dropout voltage was outside the 10.0 to 10.8-volt range, readjust control R129 and recheck until it is within these limits. Clockwise rotation of R129 increases the dropout voltage; counterclockwise rotation decreases it.

Step 8. Turn off the variable power supply and completely disconnect it from TB601.

5. MAINTENANCE

5.1 INTRODUCTION

Maintenance and repairs of this power supply demand a thorough understanding of its operation. Refer to the power supply Theory of Operation for this information.

5.2 TEST EQUIPMENT REQUIRED

The following test equipment is necessary for efficient, accurate servicing in the event that maintenance is required.

- 3-1/2 digit DVM
- DC current meter (0-50 amperes)
- Load resistor (variable from 0 ohm to 15 ohms, and capable of carrying 50 amperes)
- Variable voltage ac line transformer (0-130 volts)
- Oscilloscope
- Variable power supply
- Bench service cord consisting of:

Qty	Part No.	Description
1	15-83183N01	Housing
2	39-83145N01	Contact
1	39-83145N02	Contact
1	30-865903	Cord

5.3 AUXILIARY REGULATOR CHASSIS REMOVAL (Refer to Figure 2.)

The circuitry on the auxiliary regulator chassis can be serviced without removing the entire power supply. The auxiliary chassis below the main chassis can be disconnected and removed separately.

Step 1. Disconnect P1 and P5.

Step 2. Remove the three screws holding the auxiliary chassis to the main chassis. Use a magnetic screwdriver.

Step 3. Lift the auxiliary regulator chassis out of the cabinet.

Step 4. Remove circuit board(s) by compressing the plastic locking tabs.

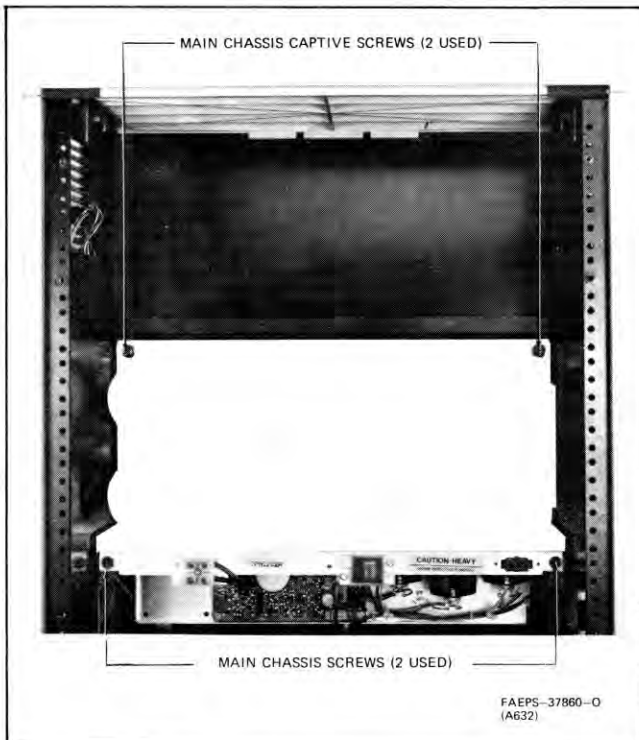

Figure 2. Power Supply Mounting Hardware

5.4 POWER SUPPLY REMOVAL (Refer to Figures 2 thru 5.)

WARNING

The power supply is unexpectedly heavy, balances sharply to the right, and is awkward to hold. Follow the removal instructions carefully.

Step 1. Disconnect P5 and P103 (for battery power supply). Open tie wraps and reposition cable.

Step 2. Remove main chassis screws and loosen main chassis captive screws. Remove the two shipping screws (Motorola Part No. 3-83498N08) and washers (Motorola Part No. 4-135873) located under the main chassis side rails. These screws need to be replaced when re-installing the power supply unless the station is to be shipped to another location. Retain the screws for future shipping needs.

Step 3. Slide power supply chassis to you until chassis is flush with cabinet as shown in Figure 3.

WARNING

DO NOT ALLOW CHASSIS TO SLIDE FREELY BEYOND FRONT OF CABINET. CABINET RAIL SUPPORT ENDS ABRUPTLY.

Step 4. Grip the main chassis with the right hand as shown in Figure 4. Find a comfortable grip around the flattened parts of the metal. Adjacent parts have sharp edges.

Step 5. Plant your feet firmly with good balance to receive a heavy weight.

Step 6. Slide the power supply toward you. Slightly tilt the chassis toward you and reach the left hand over the top to balance the chassis on the cabinet rails. Press the chassis firmly against the rails or the chassis will suddenly slide out of the cabinet. See Figure 5.

Step 7. Reposition the left hand from balancing the chassis to a firm grip.

Step 8. Brace your body to receive a heavy weight, and lift the power supply chassis free of the cabinet.

5.5 BATTERY MAINTENANCE

The battery or batteries used for emergency power require certain routine maintenance procedures to assure long trouble-free operation. Persons servicing the batteries should refer to the manufacturer's recommendations for routine maintenance. In addition, certain maintenance procedures are appropriate following each interval of emergency power operation.

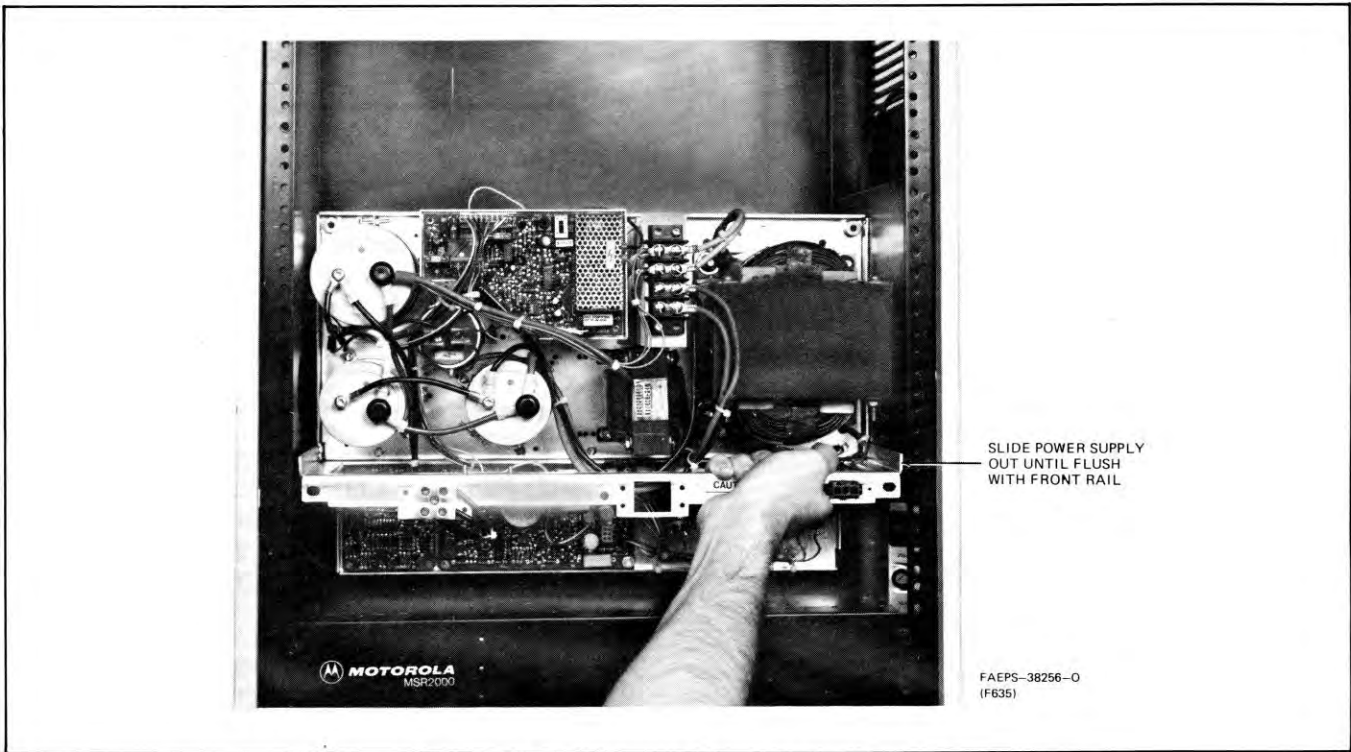

Figure 3. Power Supply Chassis Travel Distance

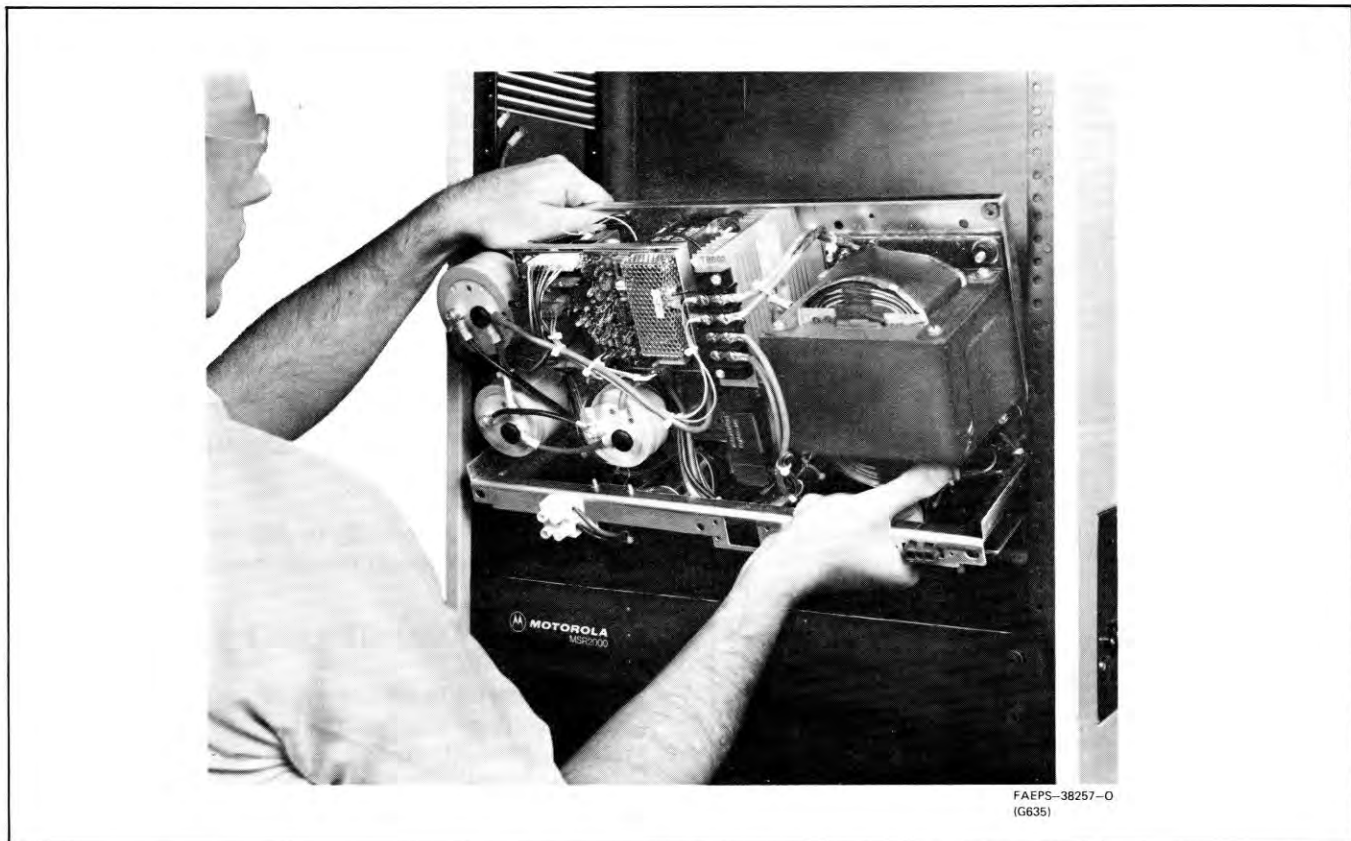

Figure 4. Properly Gripped Chassis

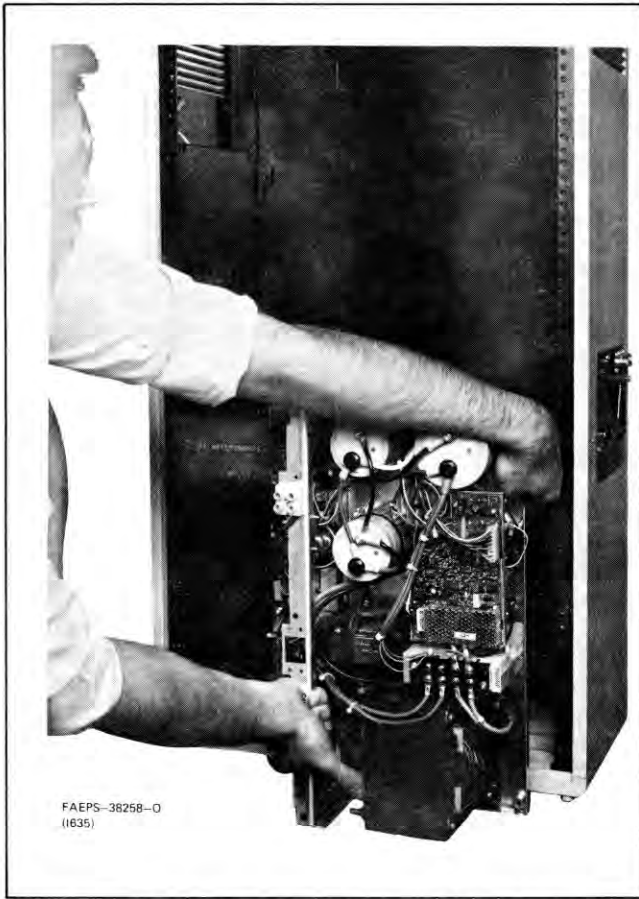

Figure 5. Power Supply Removed From Cabinet

Routine battery maintenance procedures for the two most common battery types are given (nickel-cadmium and lead-acid). The importance of keeping good battery maintenance records cannot be over-emphasized. A chart or table is needed, listing all voltage readings, temperature and hydrometer readings (where applicable), versus the dates on which the readings were taken. To be most effective, the battery report charts should be kept at the battery location for ready reference.

5.5.1 Nickel-Cadmium Batteries

Perform the following routine maintenance procedures at six-month intervals.

Step 1. Clean the battery and inspect it for damage.

Step 2. Measure cell voltages and enter the voltage readings on your maintenance report.

Most maintenance schedules require voltage readings of every cell each time maintenance is performed. If a difference of .05 volt or more exists between any two cells, apply an "equalizing charge" to the battery for 48 hours or until three consecutive cell measurements show no change (readings to be taken at 1/2-hour

intervals). The terminal voltage of the battery should then read 15.25 ± 0.2 volts.

Step 3. Add water as required to keep the electrolyte solution in each cell above minimum. Use *distilled water only*. Check the battery manufacturer's service literature for instructions on filling.

CAUTION

Do not use any tool on a nickel-cadmium battery which may have been used with lead-acid batteries. To do so may destroy the nickel-cadmium battery due to chemical contamination by electrolyte or other foreign matter from the lead-acid battery existing on the tool in question.

If frequent replacement of water is required, the charging rate may be too high. In this case, carefully check the A+ voltage with the switch in the FLOAT position for the specified 14.25 volts. Under certain high ambient temperature conditions, the battery may require water even though the charging voltage is correct. In this case, the charging voltage should be reduced until infrequent addition of water is required.

5.5.2 Lead-Acid Batteries

Perform the routine maintenance procedures monthly.

Step 1. Clean the battery and inspect it for damage.

Step 2. Measure cell voltages and enter the voltage readings on your maintenance report. Most maintenance schedules require voltage readings of every cell each time maintenance is performed. If a difference of .05 volt or more exists between any two cells, apply an "equalizing charge" to the battery for the number of hours recommended by the manufacturer.

Step 3. Take specific gravity readings with a hydrometer calibrated for the type of electrolyte used.

Step 4. Observe the necessary precautions to see that the readings are accurate, that no chemical contamination of the cells occurs, and to prevent bodily injury from contact with the electrolyte.

Step 5. After taking a reading, always return the electrolyte in the hydrometer syringe to the cell from which it came. (Failure to do so will decrease the specific gravity of the cell when water is added to fill up the cell.)

Step 6. For an accurate comparison with "standard" specific gravity readings, as published in manufacturer's specifications, a correction factor must be applied to all readings to normalize them with the standard values, when taken at temperatures other than 77° Fahrenheit. However, if the battery temperature tends to be the

same each time specific gravity readings are taken, a trend toward a change in specific gravity will be apparent without having to apply the correction factor to the readings.

The correction factor is easily applied, due to a linear relationship between changes in temperature and specific gravity above and below 77°F. For each three degrees above 77°F, add .001 (known as "1 point") to the "standard" value of specific gravity. Conversely, for each three degrees below 77°F, subtract 1 point.

Step 7. Take a specific gravity reading of the "pilot cell" monthly. It is not necessary to continually check the specific gravity of all cells, because any gradual changes usually occur simultaneously in all cells. One cell is therefore chosen and designated the "pilot cell," and the monthly routine specific gravity readings are always taken from this one cell. (Be sure to indicate on the maintenance chart which cell is the pilot cell.)

Take specific gravity readings of all the battery cells every three months, and record them on the maintenance chart.

Step 8. Add water as required to keep the electrolyte solution in each cell up to a minimum level. In some batteries, the electrolyte level should be between the high- and low-level marks on the inside of each cell. If the cells have no such markers, check the manufacturer's literature. Use *distilled water only*.

CAUTION

Do not use any tool on a lead-acid battery which may have been used with nickel-cadmium batteries. To do so may destroy the lead-acid battery, due to chemical contamination by electrolyte or other foreign matter from the nickel-cadmium battery existing on the surface of the tool in question.

If frequent replacement of water is required, the charging rate may be too high. In this case, carefully check the A+ voltage for the specified 13.0 volts with the switch in the FLOAT position. Under certain high ambient temperature conditions, the battery may require frequent water replacement even though the correct charging voltage is maintained. In this case, the

specified 13.0 volts may be reduced until infrequent addition is required.

Step 9. Equalize charging of a lead-acid battery should be performed under any one of the following conditions:

- following each known use (or discharge) of the battery,
- if the specific gravity of the pilot cell or any other cell is more than ten-thousandths (10 points) below its full-charge value,
- if the difference in voltage between any two cells is .05 volt or more,
- as part of each monthly routine maintenance procedure independent of any of the previous conditions stated.

Equalize charging should continue for: (a) the number of hours specified by the battery manufacturer, which will vary according to temperature, charging voltage and the manufacturer's recommendations or; (b) until three successive readings of cell voltage and specific gravity show *no change* (readings to be taken at 1/2-hour intervals).

5.5.3 Remote Control

Equalize charging may be remotely controlled in tone remote control base and repeater stations. This can be accomplished with a TLN2448A "Wild Card" Module and a TLN4151A Relay as shown in Figure 6. Leave the FLOAT-EQUALIZE switch in the FLOAT position.

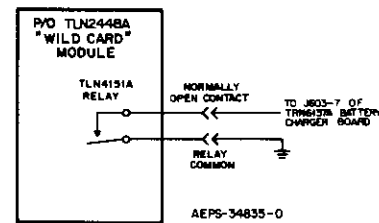

Figure 6. Remote Control of Float-Equalize

Table 3. Troubleshooting Chart

Symptom	Action
A. No Power Output	1. Check primary line connection to supply. 2. Check for correct secondary voltage (120V). 3. Check for correct polarity.
B. Battery pack is short-circuited	1. Check for correct output at pin 1, 120V. 2. If voltage is present, check for correct output from TRANSFORMER. Check for correct polarity. Check for correct output from TRANSFORMER. Check for correct output from TRANSFORMER. Check for correct output from TRANSFORMER. 3. Check OVERVOLTAGE COMPARATOR and ALL THERMISTORS for correct output. 4. Check RELAY OUTPUTS and RELAY CONTACTS for correct output.

Table 3. Troubleshooting Chart (Cont'd.)

Symptom	Action
C. A + output voltage too high and cannot adjust.	<p>Check for trigger pulses at pin 8, U650C.</p> <ol style="list-style-type: none"> 1. If no trigger present, check for proper signals from RAMP GEN. back to CLOCK GEN. If proper signals are present, check voltages at STABILIZER and CONTROL VOLTAGE GEN. 2. If correct trigger pulses are present, check power switching circuitry (Q656 through Q657).
D. A + output voltage too low.	<ol style="list-style-type: none"> 1. Check for trigger pulses at pin 8, U650C. <ol style="list-style-type: none"> a) If no trigger present, check for proper signals from RAMP GEN. back to CLOCK GEN. If proper signals are present, check voltages at STABILIZER and CONTROL VOLTAGE GEN. b) If correct trigger pulses are present, check power switching circuitry (Q656 through Q657). 2. Check power diodes CR601, CR602.
E. No regulated output voltage.	<ol style="list-style-type: none"> 1. Check for approximately 14 volts at J1-1. If no voltage, check fuse F603. 2. Check for approximately 6.5 volts at TP105, 6.5 V REF. If no voltage, check CR2 and VR1. 3. Check for grounded CR4 and CR8, REGULATOR INHIBIT lead. 4. Check for defective U1B. 5. Check for defective U1D.
F. 9.4 V regulated output: OK. No 14 V regulated output.	<ol style="list-style-type: none"> 1. Check fuses F605 and F604. 2. Check Q3 and Q4. TP105 should be 6.5 volts. 3. Check U1C. 4. Check Q2 for open circuit. 5. Check Q1 and Q11 for open circuit. 6. Check VR2 for short. 7. Check for short circuit at J5-2.
G. 14 V regulated output: OK. No 9.4 V regulated output.	<ol style="list-style-type: none"> 1. Check Q8 and Q9. TP104 should be 6.5 volts. 2. Check U1A. 3. Check Q7 for open circuit. 4. Check Q6 for open circuit. 5. Check VR3 for short circuit. 6. Check for short circuit at J5-6.
H. Regulators cannot supply full rated current of 1.5A (output drops more than 1 volt).	<ol style="list-style-type: none"> 1. Check U1D, Q3, Q4, Q8 and Q9.
I. Short circuit current greater than 0.8A, and possibly input fuse blowing.	<ol style="list-style-type: none"> 1. Overcurrent detect circuits defective. Check U1D, Q3, Q4, Q8, and Q9. 2. Check CR5 and CR10.
J. Regulated output voltages cannot be adjusted to 9.4 ± 0.1 V and 13.9 ± 0.1 V.	<ol style="list-style-type: none"> 1. Check 6.5 V REF. It should be 6.5 ± 0.2 volts. If not, check CR2, VR1, and VR4. 2. Check regulator feedback loop: U1A, Q7, and Q6; U1C, Q2, Q1, and Q11. 3. Check for high leakage Q2 and Q7.
K. High ac ripple voltage on 14 V regulated output: greater than 10 mV at 1.5A.	<ol style="list-style-type: none"> 1. Check filter capacitor C1 for low capacity or leakage. Ripple voltage at TP100 is greater than 4 V peak-to-peak. 2. Check U1C for low loop gain: less than 20 dB.
L. Voltage switched from 14 V out to main 13.8 V.	<ol style="list-style-type: none"> 1. Check relay K100. 2. Check Q101 thru Q104. 3. Check ferroresonant controller and fuses. 4. Check ac power.
M. Regulator inhibit low and regulators shut down.	<ol style="list-style-type: none"> 1. Check Q105. 2. Check U100A. 3. Check Q101 and Q102. 4. Check battery voltage.
N. Continuous tone out.	<ol style="list-style-type: none"> 1. Check U100A, B and D. 2. Check battery voltage. 3. Check ferroresonant controller.
O. Pulsed tone out.	<ol style="list-style-type: none"> 1. If AC FAIL is low, check primary circuits and fuses. 2. If AC FAIL is not low, check Q102, CR109, and Q101.
P. AC FAIL or 0 V ALARM low, and no tone.	<ol style="list-style-type: none"> 1. If no tone at TP103, check U100C, Q102, R120, R139, phase shift network and U100C. 2. If there is a tone at TP103 and JU102 is in, readjust R128.

parts list

TRN5299A Chassis PL-8013-O

REFERENCE SYMBOL	MOTOROLA PART NO.	DESCRIPTION
Q1,6,11	48-869672	diode: (see note) PNP, type M9672
P3	15-83498F39	connector: HOUSING, 3 position (WHT)
P4	15-83498F40	HOUSING, 3 position (RED)
P7	15-83498F39	HOUSING, 3 position (WHT)
mechanical parts		
3-136143		SCREW, tapping: 8-32 x 1/4"; 6 used
43-83561N01		STANDOFF, twist lock; 2 used
3-136850		SCREW, tapping: 6-32 x 1/2"; 6 used
9-82973A01		SOCKET, transistor; 3 used
14-865854		INSULATOR; 3 used
26-82979N01		HEAT SINK; 3 used
29-83499F01		TERMINAL; 9 used

note: For optimum performance, diodes, transistors, and integrated circuits must be ordered by Motorola part numbers.

TRN5297A Hardware Kit PL-8014-O
TRN5298A Hardware Kit

REFERENCE SYMBOL	MOTOROLA PART NO.	DESCRIPTION
P6,101	15-83498F38	connector: HOUSING, 2 position
mechanical parts		
3-134185		SCREW, tapping: 6-32 x 1/4"
43-82980N01		STANDOFF; 3 used TRN5297A; 5 used TRN5298A
43-82980N02		STANDOFF, spacer; 2 used TRN5298A
43-83561N01		STANDOFF, twist lock; 2 used
1-80754D87		Assembly Wire and Lug includes: (p/o TRN5297A)
29-83499F01		TERMINAL; 2 used
1-80754D97		Assembly Wire and Lug includes: (p/o TRN5298A)
29-83499F01		TERMINAL; 2 used
1-80754D98		Assembly Wire and Lug includes: (p/o TRN5298A)
29-83499F01		TERMINAL; 2 used
42-10217A02		STRAP, ties

TRN5362A Interconnect Battery Charger Hardware PL-8016-B

REFERENCE SYMBOL	MOTOROLA PART NO.	DESCRIPTION
P1,603	15-83498F45	connector: HOUSING; 9 position
R140	17-83389G02	resistor: 30 ohms \pm 5%; 20 W
mechanical parts		
3-83498N04		SCREW, tapping: M4 x 0.7 x 7mm; 3 used
46-84549F01		PLUG, polarizing
29-83499F01		TERMINAL; 16 used
3-10943M25		SCREW, tapping M4 x 0.7 x 20mm; 2 used
29-82907N01		TERMINAL, ring
29-812979		TERMINAL

TKN8295A Internal Battery Cable Kit PL-8017-D
TKN8845A Internal Battery Cable Kit (DC Only)

REFERENCE SYMBOL	MOTOROLA PART NO.	DESCRIPTION
J605	15-83502N01 39-83503N01	connector, receptacle: assembly connector, includes: HOUSING, single contact; 2 used CONTACT, battery; 2 used
mechanical parts		
7-83504N01		BRACKET, male mounting
7-83505N01		BRACKET, female mounting
2-10971A18		NUT, machine: M5 x 0.8; 2 used
3-83497N02		SCREW, machine: M5 x 0.8 x 12 mm; 2 used
4-7658		WASHER, lock: #10 internal; 2 used
42-10217A02		STRAP, tie: .091 x 3.62; 3 used

TRN5153A Battery Charger P.S. Hardware Kit PL-8018-B

REFERENCE SYMBOL	MOTOROLA PART NO.	DESCRIPTION
L650	25-82419N01	coil, rf: 65 mh
P606	15-83142M08	connector, plug: HOUSING, 4 position
K650	80-83013N01	relay: 1 form "C"; coil res, 70 ohms
mechanical parts		
2-10971A17		NUT, machine: M4 x 0.7 hex
3-83497N03		SCREW, machine
3-83497N02		SCREW, machine: M5 x 0.8 x 12mm
3-83498N04		SCREW, tapping: M4 x 0.7 x 7mm; 4 used
3-83498N06		SCREW, tapping: M4 x 0.7 x 16mm; 2 used
4-7651		LOCKWASHER: #8 internal; 3 used
5-82904N02		GROMMET, transformer; 4 used
7-83364N01		BRACKET, charger board
15-83901N01		COVER, battery; option, board
29-82907N01		TERMINAL, ring; 2 used
29-83113N02		TERMINAL, right angle; 2 used
39-82717M01		CONTACT, receptacle; 4 used
39-83503N01		CONTACT, battery connector; 2 used
2-10971A18		NUT; M5 x 0.8
4-7658		LOCKWASHER: #10 internal
14-83986N01		INSULATOR
29-82907N03		TERMINAL, ring: 10 ga.; 2 used
43-82980N03		STANDOFF; 6 used
42-10217A02		STRAP, tie: nylon
54-83971N01		LABEL

TRN5155A External Battery Cable Kit PL-8059-B

REFERENCE SYMBOL	MOTOROLA PART NO.	DESCRIPTION
F610	65-82846N01	fuse: 60 amp; 300 V
P605	15-83502N01 39-83503N01	connector, plug: assembly, connector, includes: HOUSING, single contact; 2 used CONTACT, battery; 2 used
mechanical parts		
3-138490		SCREW, tapping: 8-18 x 1 1/4"; 2 used
9-82842N01		BLOCK, fuse
29-847817		LUG, ring tongue; 2 used
42-10217A02		STRAP, tie; 3 used

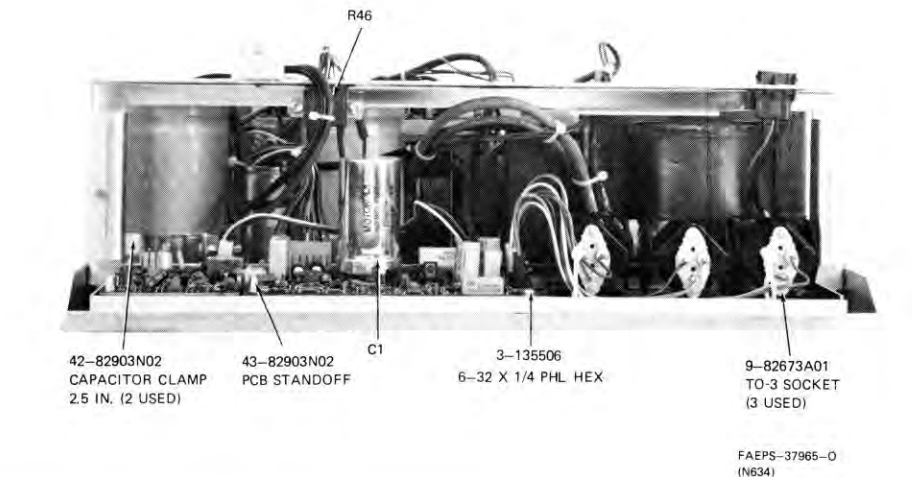
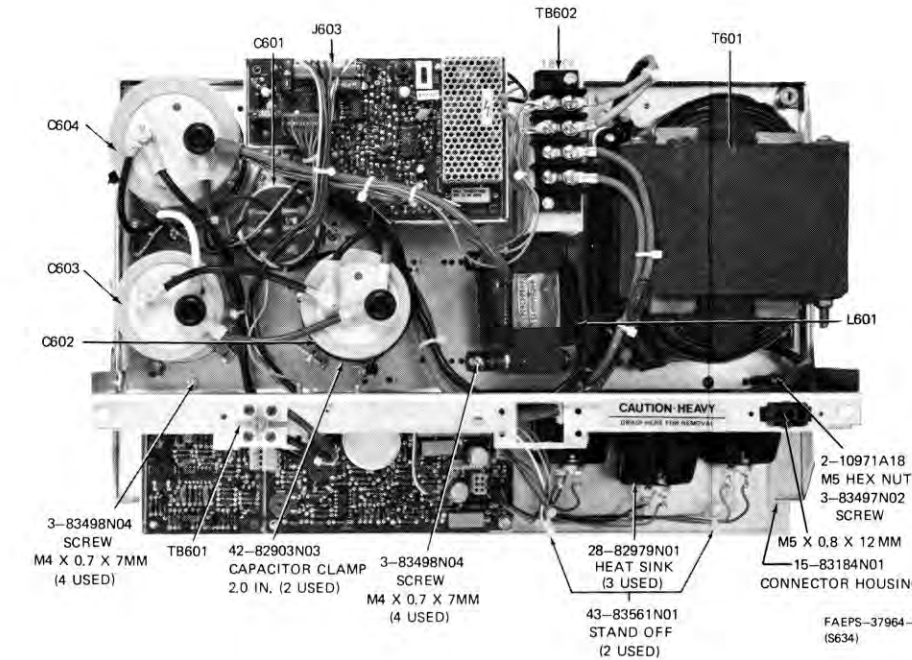
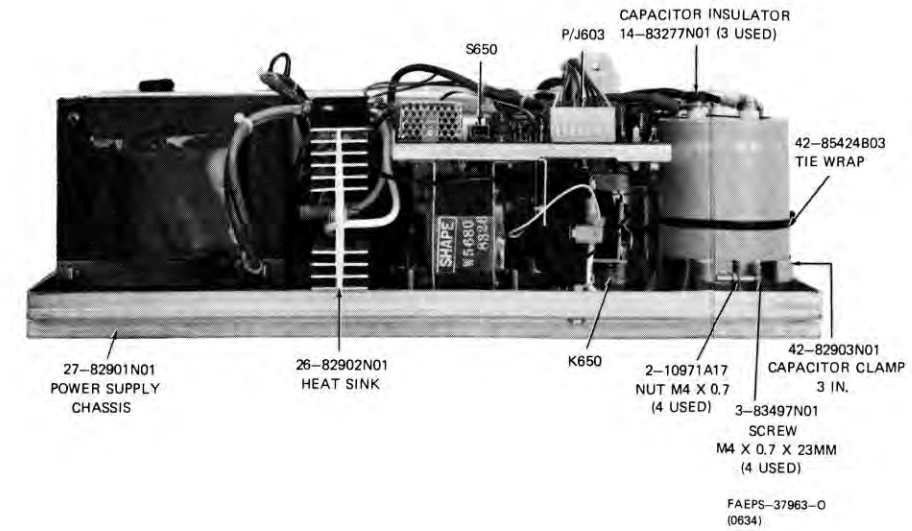

Parts Lists and Location
Motorola No. PEPS-34743-B
10/31/83 - V & G

OPTION C28AN
BATTERY CHARGER POWER SUPPLY
 MODEL TPN1192A

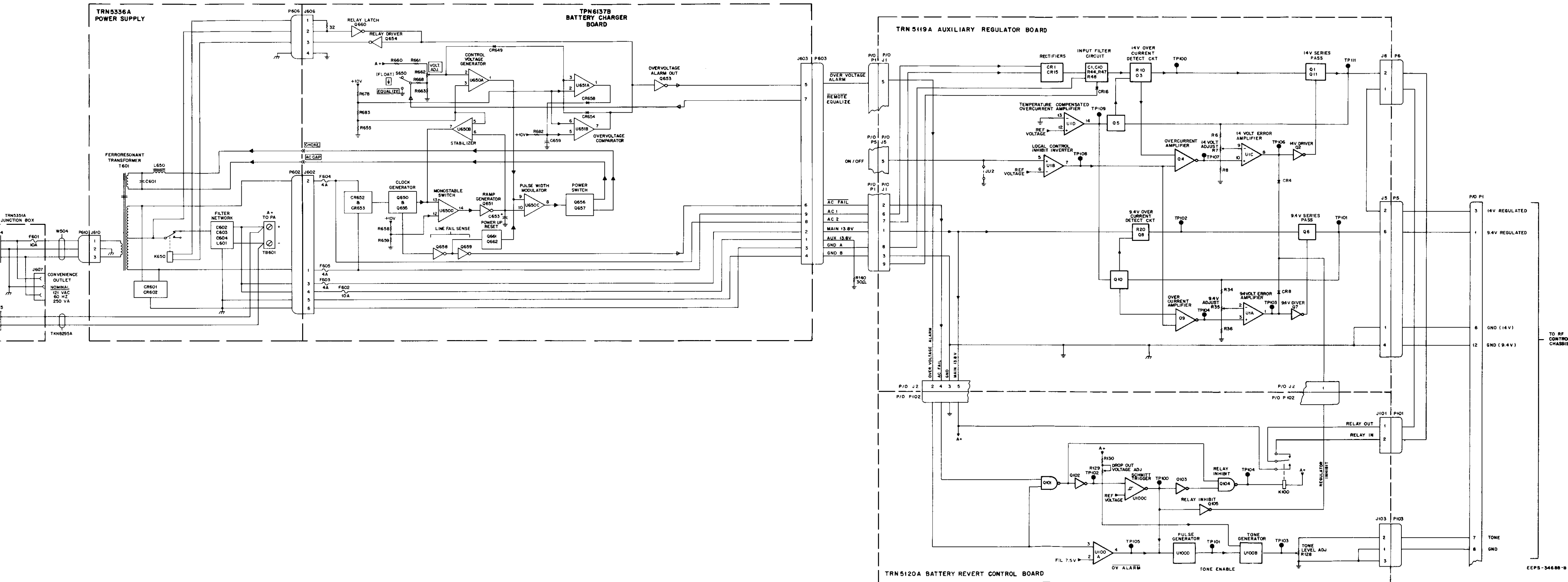

BATTERY CHARGER POWER SUPPLY

EEPS-34688-B

OPTION C28AN BATTERY CHARGER POWER SUPPLY

MODEL TPN1192A

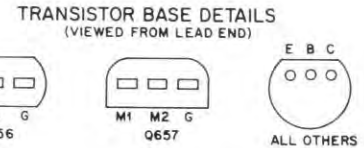
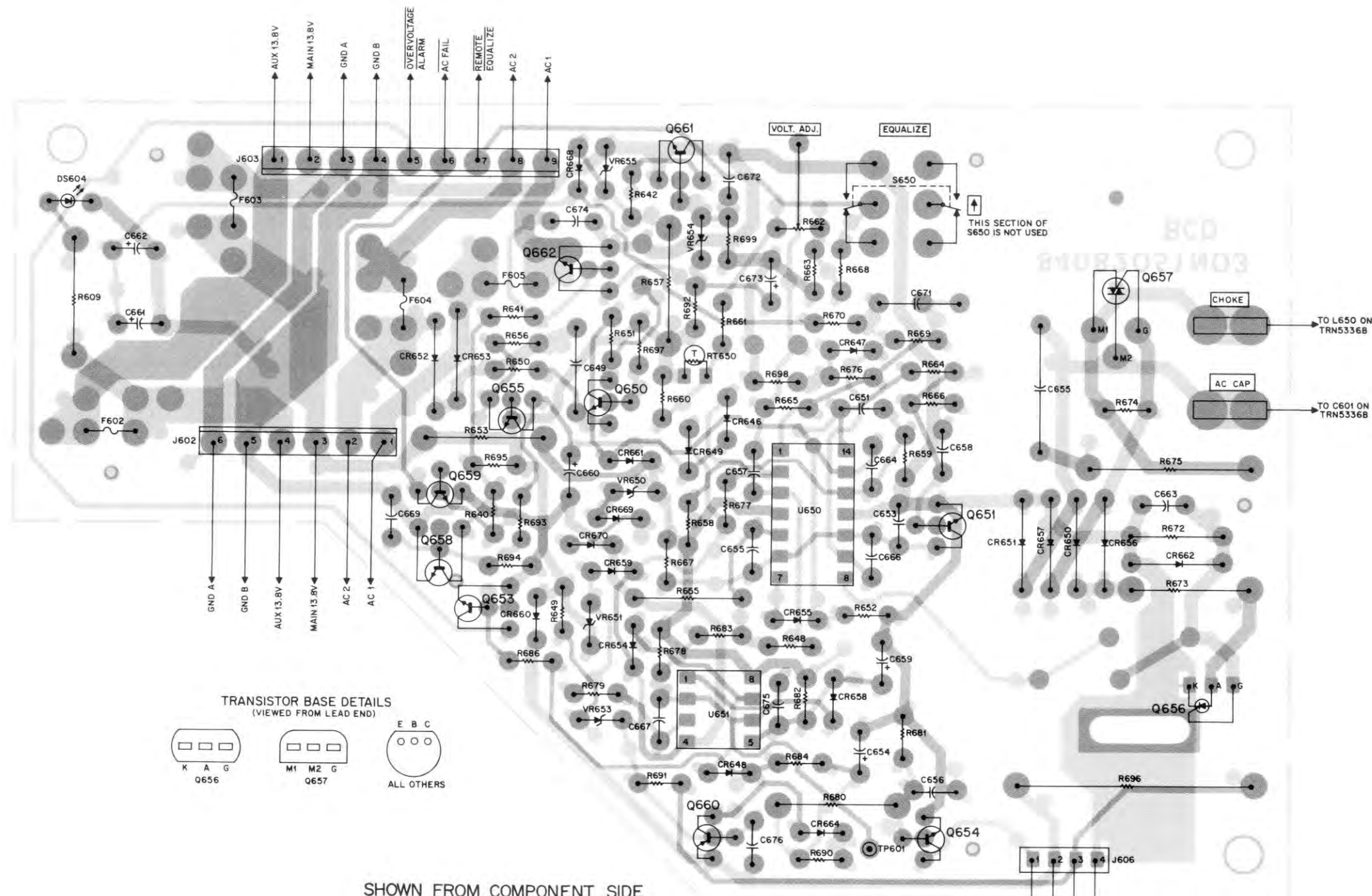

SHOWN FROM COMPONENT SIDE

SOLDER SIDE BD-DEPS-36445-0
COMPONENT SIDE BD-DEPS-36446-0
OL-DEPS-36447-0

TRN5336A Standard Power Supply, and
TPN6137B Battery Charger Board
Schematic Diagram, Circuit Board Detail,
and Parts Lists
Motorola No. PEPS-34740-C
(Sheet 1 of 2)
10/31/83 - V & G

parts list

TPN6137B Battery Charger Circuit Board

PL-8495-A

REFERENCE SYMBOL	MOTOROLA PART NO.	DESCRIPTION
C649	21-82372C05	capacitor, fixed: uF ± 20%; 25 V; unless otherwise stated
C650	8-84637L34	0.2 + 80-20%
C651	8-11017A09	.33 ± 10%; 50 V
C653	8-11017A10	.015 ± 5%; 50 V
C654	23-11019A40	.018 ± 5%; 50 V
C655	8-82860N01	47
C656, 657, 658	21-11014H32	.047 ± 10%, 250 V
C659	23-11019A40	20 pF ± 5%; 100 V
C660	23-11019A11	47 ± 10%
C661, 662	23-11019A48	2.2; 50 V
C663 thru 667	21-11014H32	220; 10 V
C668	21-83596E20	20 pF ± 5%; 100 V
C669	21-11014H32	.01 ± 20%; 1000 V
C670	21-11014H32	20 pF ± 5%; 100 V
C671	8-84637L22	NOT USED
C672	21-11014H32	.22 ± 10%; 100 V
C673	23-11019A46	20 pF ± 5%; 100 V
C674, 675, 676	21-11014H32	100 ± 20%; 25 V
C674, 675, 676	21-11014H32	20 pF ± 5%; 100 V
CR646 thru 649	48-11034D01	diode: (see note)
CR650, 651	48-82466H18	silicon
CR652, 653	48-82466H13	silicon
CR654, 655	48-11034D01	silicon
CR656, 657	48-82466H18	silicon
CR658, 659	48-11034D01	silicon
CR660	48-82466H18	silicon
CR661	48-11034D01	silicon
CR662	48-83654H01	silicon
CR663, 664, 665	48-11034D01	silicon
CR668, 669, 670	48-11034D01	silicon
DS604	48-84404E04	light emitting diode: (see note)
F602	65-139767	fuse:
F603, 604, 605	65-82859N01	10 amp; 32 V
F603, 604, 605	65-82859N01	4 amp; 32 V
J602	28-82984N06	connector, plug:
J603	28-82984N10	male; 6-contact
J606	28-83143M05	male; 9-contact
J606	28-83143M05	male; 4-contact
Q650	48-869643	transistor: (see note)
Q651	48-869642	PNP; type M9643
Q653	48-869642	NPN; type M9642
Q654	48-869648	NPN; type M9642
Q655	48-869643	NPN; type M9643
Q656	48-82604N01	silicon controlled rectifier
Q657	48-82965F02	TRIAC; 15 amp; 800 V
Q658	48-869642	NPN; type M9642
Q659	48-869528	NPN; type M9528
Q660	48-869643	PNP; type M9643
Q661, 662	48-869642	NPN; type M9642
R609	6-125C51	resistor, fixed: ± 5%; 1/4 W;
R640, 641	6-11009E49	unless otherwise stated
R642	6-125A33	1.2k ± 10%; 1/2 W
R648	6-11009E89	1k
R649	6-11009E61	47k
R650	6-11009E56	3.3k
R651	6-11009E63	2k
R652	6-11009E60	3.9k
R653	6-125A31	3k
R655	6-84640C25	180; 1/2 W
R656	6-11009E56	2.1k ± 1%
R657	6-125C35	2k
R658	6-11009F12	270; 1/2 W
R659	6-11009F08	390k
R660	6-11009F08	270k
R661	6-11009E57	2.2k
R662	6-11009E67	5.6k
R663	18-82374N10	variable: 1k; 0.25 W
R664	6-11009E61	3.3k
R665	6-11009E63	3.9k
R666	6-11009E85	33k
R667	6-11009E53	1.5k
R668	6-11009F10	330k
R669	6-11009E83	27k
R670	6-11009E89	47k
R671	6-11009E55	1.8k
R672	6-11009E49	1k
R673	6-125C59	2.7k ± 10%; 1/2 W
R674	6-11009E29	150
R675	6-126A49	1k; 1 W, 5%
R676	6-11009E65	4.7k
R677	6-11009E89	47k
R678	6-11009E55	1.8k
R679	6-11009E44	620
R680	6-125A45	680; 1/2 W, 5%
R681	6-11009E53	1.5k

REFERENCE SYMBOL	MOTOROLA PART NO.	DESCRIPTION
R682	6-11009E95	82k
R683	6-11009E35	270
R684	6-11009E57	2k
R686	6-11009E73	10k
R690	6-11009E33	220
R691	6-11009E37	330
R692	6-11009E56	2k
R693	6-11009E65	4.7k
R694	6-11009E53	1.5k
R695	6-11009E65	4.7k
R696	17-82177B02	32; 5 W
R697	6-11009E49	1k
R698	6-11009E81	22k
R699	6-11009E89	47k
RT650	6-82769A08	thermistor: 2.02k @ 25 °C
S650	40-83204B02	switch: dpdt
U650	51-83629M58	integrated circuit: (see note)
U651	51-83629M77	quad operational amplifier dual operational amplifier
VR650	48-82256C56	voltage regulator: Zener; 8.8 V
VR651	48-82256C25	Zener; 12 V
VR652	48-83461E40	Zener; 5.1 V
VR653	48-82256C63	Zener; 17 V
VR654, 655	48-83461E30	Zener; 6.2 V
mechanical parts		
	2-10971A16	NUT; M3-0.5
	3-83497N04	SCREW, machine; M3 x 0.5 x 8mm
	4-7683	LOCKWASHER, #4 internal
	14-83820M02	INSULATOR, transistor
	26-84275L01	HEAT SINK
	29-82906N01	TERMINAL, blade fuse; 8 used
	29-10231A10	TERMINAL, mounting faston; 2 used
TRN5336A Power Supply Hardware Kit (500 W) PL-8020-B		
REFERENCE SYMBOL	MOTOROLA PART NO.	DESCRIPTION
C601	8-82682N01	capacitor, fixed: 20 uF ± 6%; 330 V
C602, 603	23-82681N01	64,000 uF + 75-7%; 20 V
C604	23-82681N02	120,000 uF + 75-10%; 20 V
CR601, 602	48-82732C09	diode: (see note) silicon
P602	9-83360N01	connector, receptacle: female; 6 contact
L601	25-82686N01	coil: choke; 420 uH
T601	25-82253N01	transformer: power: 500 W; 60 Hz
TB601	31-83576K02	terminal, board: 2-terminals
mechanical parts		
	2-10971A17	NUT, machine; M4 x 0.7 hex; 4 used
	2-10971A18	NUT, machine; M5 x 0.8 hex; 4 used
	3-10907A55	SCREW, machine; M6 x 1 x 25mm; 4 used
	3-83497N01	SCREW, machine; M4 x 0.7 x 25mm; 4 used
	3-83497N02	SCREW, terminal; M5 x 0.8 x 12mm; 6 used
	3-83498N04	SCREW, tapping; M4 x 0.7 x 7mm; 18 used
	3-83498N06	SCREW, tapping; M4 x 0.7 x 16mm; 2 used
	3-83678N02	SCREW, tapping; M3 x 0.5 x 5mm
	4-7651	LOCKWASHER, #8 internal; 10 used
	4-83499N01	WASHER, insulator; 3 used
	4-7658	LOCKWASHER, #10 internal; 20 used
	5-82904N01	GROMMET; 4 used
	14-83277N01	INSULATOR, lug; 3 used
	14-84088N01	INSULATOR, cap terminals; 2 used
	14-84548A01	INSULATOR, washer; 2 used
	26-82902N01	HEAT SINK
	29-824456	LUG, ring tongue; 2 used
	29-845081	LUG, ring tongue; 2 used
	29-82907N02	TERMINAL, ring
	29-82907N03	TERMINAL, ring; 4 used
	29-83113N01	TERMINAL, right angle; 6 used
	29-83137N01	TERMINAL, splice; 2 used
	39-83146N01	CONTACT, socket
	42-85238	CLAMP, cable; 2 used
	42-10217A02	STRAP, tie; .091 x 3.62; 16 used
	42-35424B03	STRAP, tie; .094 x 14; 3 used
	42-82903N01	CLAMP, cap; 2"
	42-82903N02	CLAMP, cap; 2 1/2"; 2 used
	42-82903N03	CLAMP, cap; 3"
	43-82980N03	STANDOFF; 4 used
	29-824154	TERMINAL, ring non-insulated; 4 used
	29-82907N01	TERMINAL, ring; 18-22GA; 2 used

note: For optimum performance, diodes, transistors, and integrated circuits must be ordered by Motorola part numbers.

OPTION C28AN BATTERY CHARGER POWER SUPPLY MODEL TPN1192A

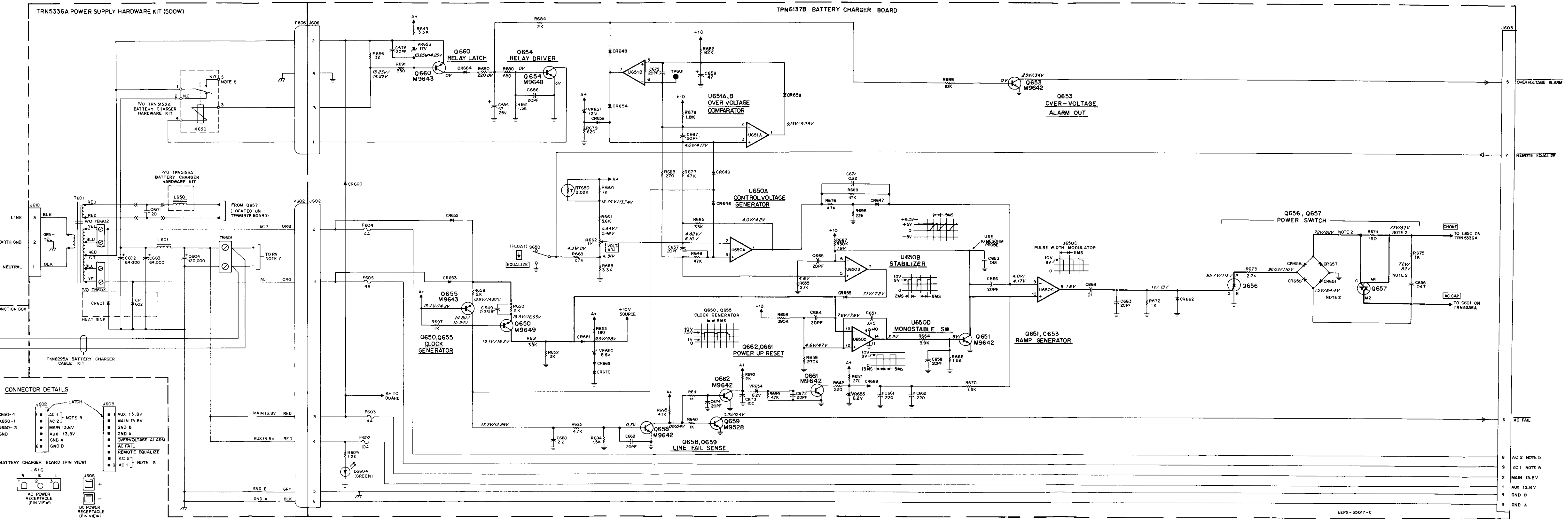

- NOTES:
1. Unless specified otherwise, all capacitor values are in microfarads and resistor values in ohms.
 2. Waveform is non-sinusoidal. Voltage in recorded rms.
 3. Voltages measured with DVM, with 1 meg ohm or greater input impedance.
 4. Voltages measured correspond to SW850 = float position/equalize position, 120 V ac line, 2A load current, with output voltage set to 13.2V in the float position by R662. Voltage measured @ TB601.
 5. Used in MSR 2000 stations only.
 6. To J1-9 of TRN5119A Auxiliary regulator board in MSR 2000 stations only.
 7. The + and - wires from TB601 connect to TB801 on MSR 2000 stations and directly to the power amplifier on MSF 5000 stations.

TRN5336A Standard Power Supply, and
TPN6137B Battery Charger Board
Schematic Diagram, Circuit Board Detail,
and Parts Lists
Motorola No. PEPS-34740-C
(Sheet 2 of 2)
10/31/83 - V & G

BATTERY CHARGER POWER SUPPLY

OPTION C28AN BATTERY CHARGER POWER SUPPLY

MODEL TPN1192A

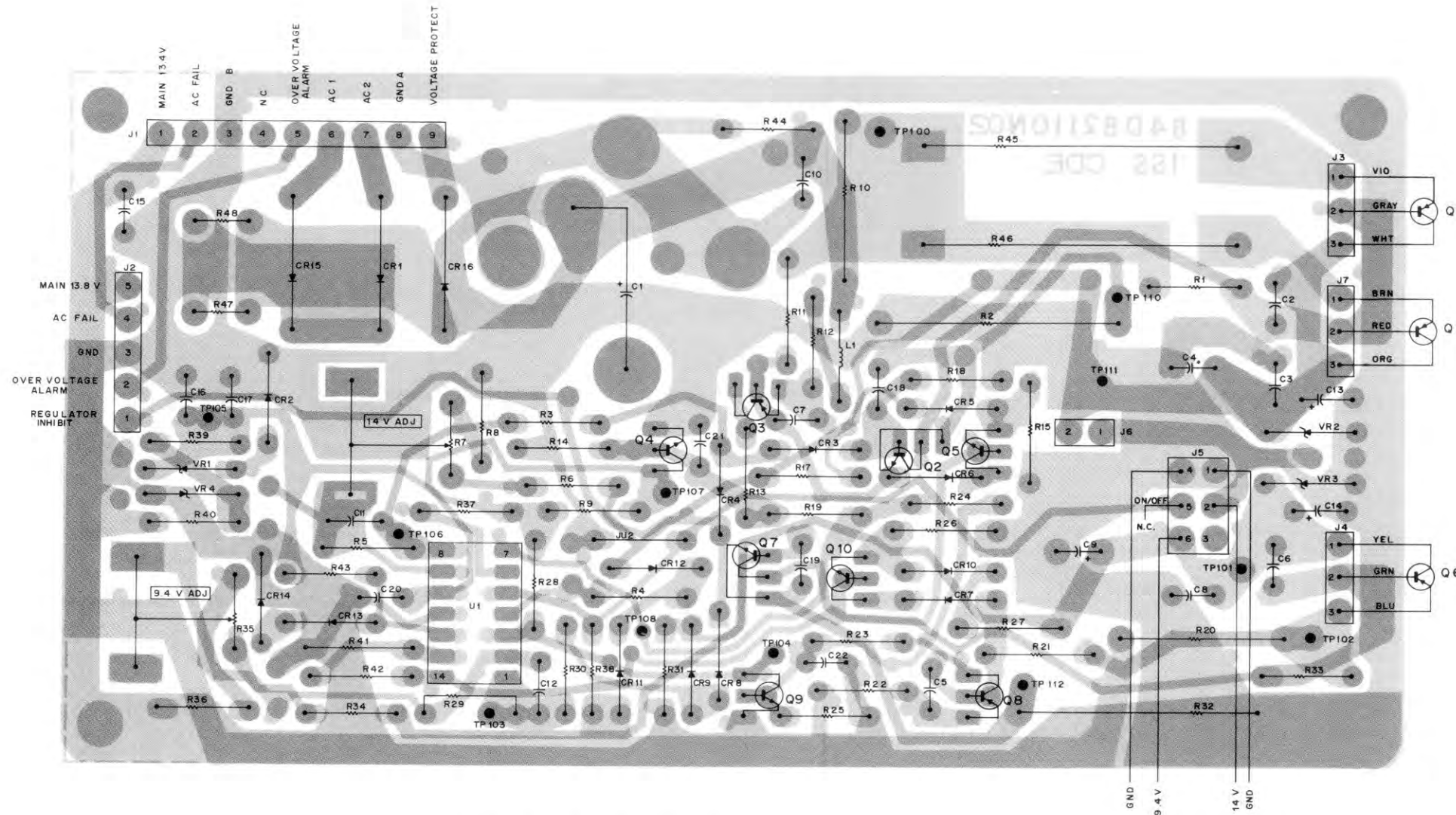

SHOWN FROM COMPONENT SIDE

SOLDER SIDE — BD DEPS-34349-A
COMPONENT SIDE — BD DEPS-34350-A
OL DEPS-34351-A

parts list

TRN5119A Auxiliary Regulator Board

PL-7945-O

REFERENCE SYMBOL	MOTOROLA PART NO.	DESCRIPTION
C1	23-82394A19	capacitor, fixed: uF: 3600 + 150-10%; 40 V
C2, 3	21-11015B13	.001 ± 10%; 100 V
C4	23-84665F15	330 + 10-50%; 25 V
C5 thru 8	21-11015B13	.001 ± 10%; 100 V
C9	23-84665F15	330 + 10-50%; 25 V
C10	21-11015B13	.001 ± 10%; 100 V
C11, 12	21-82428B21	.01 + 10-30%; 100 V
C13, 14	23-84538G02	4.7 ± 20%; 20 V
C15, 16	21-11015B13	.001 ± 10%; 100 V
C17	21-11022G39	24 pF ± 5%; 50 V
C18, 19	21-11015B13	.001 ± 10%; 100 V
C20	21-11022G39	24 pF ± 5%; 50 V
C21, 22	21-11015B13	.001 ± 10%; 100 V
CR1	48-82525G13	diode: (see note) silicon
CR2 thru 12	48-83654H01	silicon
CR13, 14	48-82392B12	silicon
CR15	48-82525G13	silicon
CR16	48-82525G19	silicon
J1	29-82984N12	connector, receptacle: male; 8-contact
J2	9-83497F08	female; 5-contact
J3	28-82984N02	male; 3-contact
J4	28-82984N03	male; 3-contact
J5	1-80754D88 15-84953L01 39-82977N01	Assembly connector, consists of: Housing, receptacle; 6-position Contact, receptacle; 6 used
J6	28-82984N01	male; 2-contact
J7	28-82984N02	male; 3-contact
JU2	6-11009B23	jumper: "0" ohms
L1	24-83961B01	coil, rf: choke
Q2	48-869633	transistor: (see note) NPN; type M9833
Q3	48-869643	PNP; type M9643
Q4, 5	48-869642	NPN; type M9642
Q7	48-869633	NPN; type M9833
Q8	48-869643	PNP; type M9643
Q9, 10	48-869642	NPN; type M9642
R1	6-11009A49	resistor, fixed: ± 5%; 1/4 W: 1k
R2	17-82177B16	100 ± 10%; 5 W
R3	6-11009A57	2.2k
R4	6-11009A03	12
R5	6-11009A99	120k
R6	6-11009A59	2.7k
R7	18-83083G14	var. 1k
R8	6-11009A58	2.4k
R9	6-11009A69	6.8k
R10	17-82036G24	0.13; 2 W
R11	6-84444A01	332 ± 1%; 1/8 W
R12	6-11009A25	100
R13	6-11009A73	10k
R14	6-11009A57	2.2k
R15	6-10621C81	7.87k ± 1%; 1/8 W
R17	6-10621C79	7.5k ± 1%; 1/8 W
R18	6-11009A61	3.3k
R19	6-11009A73	10k
R20	17-82036G24	0.13; 2 W
R21	6-84444A01	332 ± 1%; 1/8 W
R22	6-11009A25	100
R23, 24	6-11009A73	10k
R25	6-11009A57	2.2k
R26	6-10621C81	7.87k ± 1%; 1/8 W
R27	6-10621C79	7.5k ± 1%; 1/8 W
R28	6-11009A69	6.8k
R29	6-11009A99	120k
R30	6-11009A57	2.2k
R31	6-11009A61	3.3k
R32	17-82177B16	100 ± 10%; 5 W
R33	6-11009A33	220
R34	6-11009A53	1.5k
R35	18-83083G14	var. 1k
R36	6-11009A63	3.9k
R37, 38	6-11009A89	47k
R39	6-11009A53	1.5k
R40	6-11009A39	390
R41	6-84444A09	2.43k ± 1%
R42	6-10621D05	13.7k ± 1%; 1/8 W
R43, 44	6-11009A73	10k
R45, 46	17-82177B64	2.6; 10 W
R47, 48	17-82177B12	0.7 ± 10%; 5 W

REFERENCE SYMBOL	MOTOROLA PART NO.	DESCRIPTION
U1	51-83629M08	integrated circuit: (see note) quad op amp
VR1	48-82256C61	voltage regulator: (see note) Zener, 5.8 V
VR2	48-82256C63	Zener, 17 V
VR3	48-82256C13	Zener, 14 V
VR4	48-82256C11	Zener, 10 V

note: For optimum performance, diodes, transistors and integrated circuits must be ordered by Motorola part numbers.

OPTION C28AN BATTERY CHARGER POWER SUPPLY MODEL TPN1192A

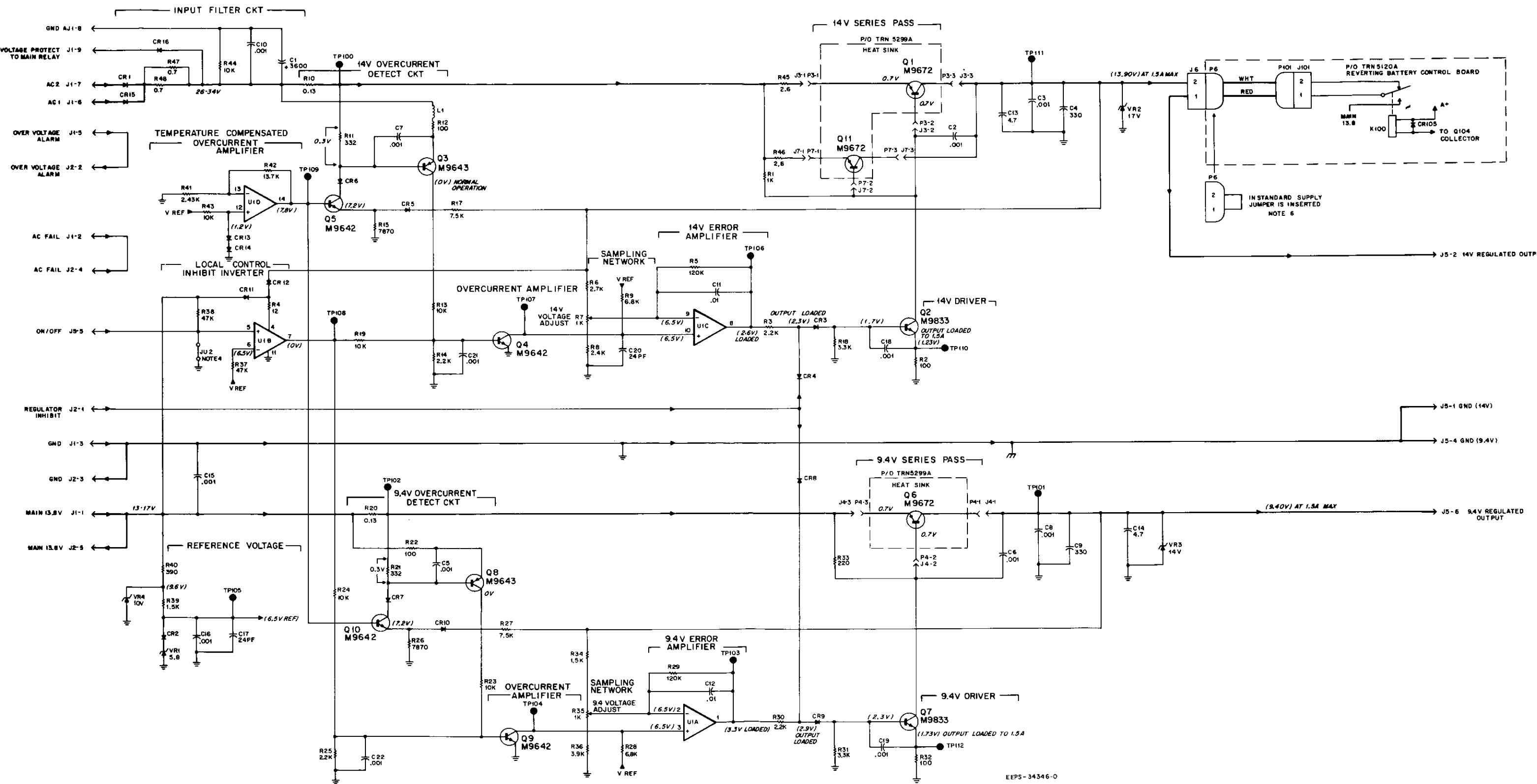

- NOTES:
1. Unless otherwise indicated, resistor values are in ohms; capacitor values are in microfarads; and inductor values are in millihenries.
 2. Integrated circuits on this board are silicon monolithic.
 3. IC types and connections for this board are as follows:
- | Reference Designation | VCC | Gnd | Mfg's Description |
|-----------------------|-----|-----|-------------------|
| U1 | 4 | 11 | Op-Amp |
4. Remove JU2 when on/off switch (in local control models) is used.
 5. DC voltages are nominal. Full rated load. () Other - no load voltages.
 6. For non-battery supply (standard supply) insert connector jumper.

TRN5119A Auxiliary Regulator Board
Schematic Diagram, Circuit Board Detail,
and Parts Lists
Motorola No. PEPS-34738-B
(Sheet 2 of 2)
10/31/83 - V & G

BATTERY CHARGER POWER SUPPLY

OPTION C28AN BATTERY CHARGER POWER SUPPLY

MODEL TPN1192A

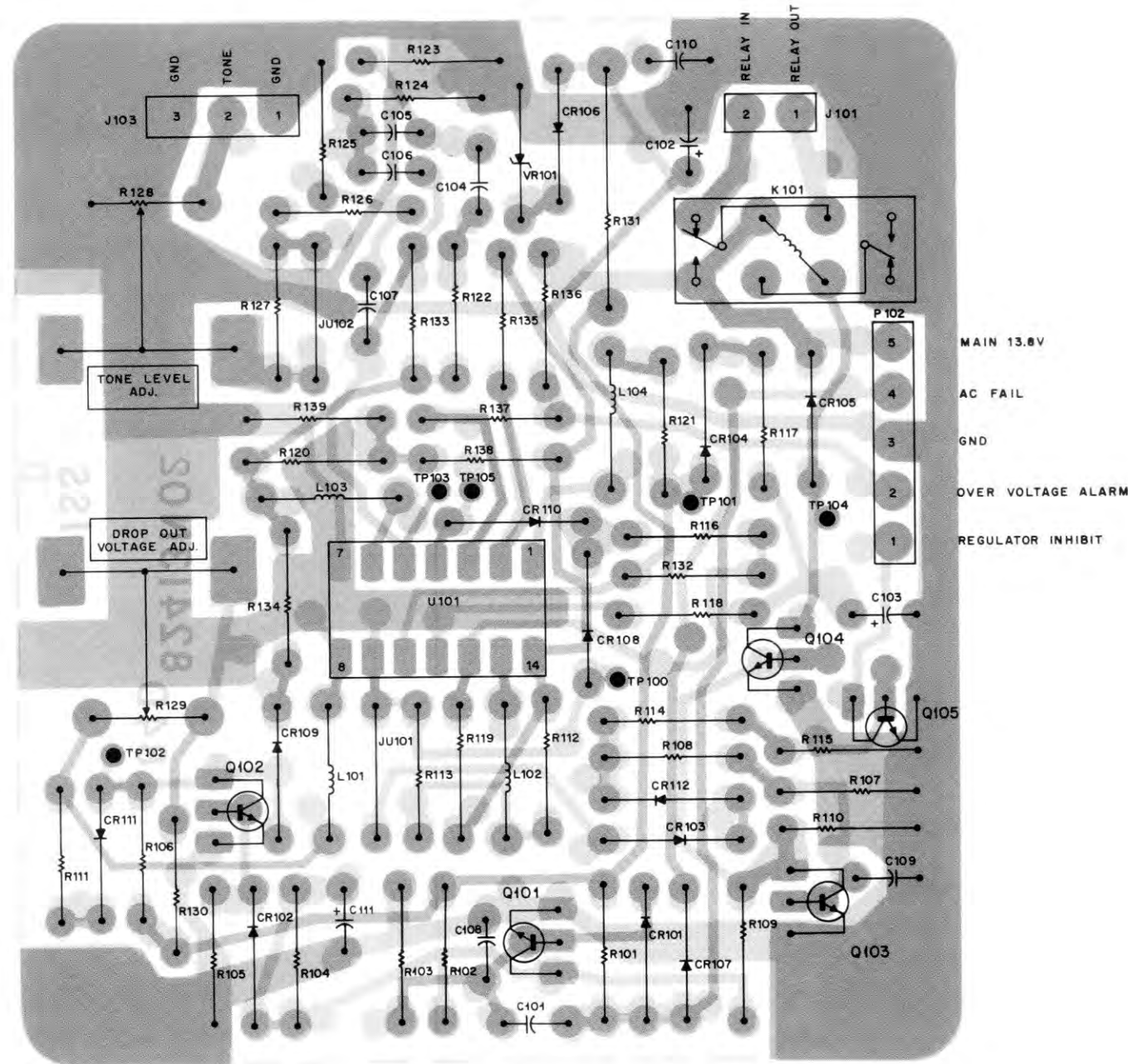

SHOWN FROM COMPONENT SIDE

SOLDER SIDE BD CEPS-34352-A
COMPONENT SIDE BD CEPS-34353-A
OL CEPS-34354-A

parts list

TRN5120A Battery Revert Control Board

PL-7946-A

REFERENCE SYMBOL	MOTOROLA PART NO.	DESCRIPTION
capacitor, fixed: uF: unless otherwise stated		
C101	21-11015B05	220 pF ± 10%; 100 V
C102	23-11019A20	10 ± 20%; 25 V
C103	23-11013C07	10 ± 10%; 15 V
C104, 105, 106	8-11017A05	.0033 ± 5%; 50 V
C107	8-11017B17	0.1 ± 10%; 50 V
C108, 109, 110	21-11015B05	220 pF ± 10%; 100 V
C111	23-11019A27	22 ± 20%; 25 V
diode: (see note)		
CR101 thru 104	48-83654H01	silicon
CR105, 106	48-82466H18	silicon
CR107 thru 112	48-83654H01	silicon
connector, receptacle:		
J101	28-82984N01	male, 2-contact
J103	28-82984N02	male; 3-contact
jumper:		
JU101, 102	6-11009B23	resistive
relay:		
K100	80-84134D01	dpdt
coil, rf:		
L101 thru 104	24-83961B02	5-turns; coded GRN
connector, plug:		
P102	28-83274N02	male: 5-contact; right angle
transistor: (see note)		
Q101, 102, 103	48-869642	NPN; type M9642
Q104	48-869648	NPN; type M9648
Q105	48-869642	NPN; type M9642
resistor, fixed: ± 5%; 1/4 W: unless otherwise stated		
R101	6-11009A73	10k
R102	6-11009A89	47k
R103	6-11009A56	2k
R104	6-11009A81	22k
R105	6-11009A89	47k
R106	6-11009A73	10k
R107	6-11009A89	47k
R108	6-11009A73	10k
R109	6-11009A55	1.8k
R110	6-11009A89	47k
R111	6-11009A97	100k
R112	6-10621E61	562k ± 1%; 1/8 W
R113	6-11009B22	1 meg
R114	6-11009A65	4.7k
R115, 116	6-11009A89	47k
R117	6-11009A83	27k
R118	6-11009B09	300k
R119, 120, 121	6-11009B22	1 meg
R122, 123, 124	6-11009A75	12k
R125	6-11009A73	10k
R126	6-11009A49	1k
R127	6-11009B14	470k
R128, 129	18-83083G31	var. 250k
R130	6-1100B19	750k
R131	6-126C29	150 ± 10%; 1 W
R132	6-11009B22	1 meg
R133	6-11009B14	470 k
R134	6-11009B22	1 meg
R135	6-11009A97	100k
R136	6-11009A73	10k
R137	6-11009A97	100k
R138	6-11009B05	200k
R139	6-11009A97	100k
integrated circuit: (see note)		
U100	51-83629M72	quad op amp
voltage regulator: (see note)		
VR101	48-83461E42	Zener, 6.8 V
mechanical parts		
43-82980N01	STAND-OFF, board support; 2 used	
43-82980N02	STAND-OFF, board spacer; 2 used	
15-83498F38	HOUSING, connector: 2-position; 2 used	
29-83499F01	TERMINAL; 4 used	

note: For optimum performance, diodes, transistors, and integrated circuits must be ordered by Motorola part numbers.

OPTION C28AN BATTERY CHARGER POWER SUPPLY

MODEL TPN1192A

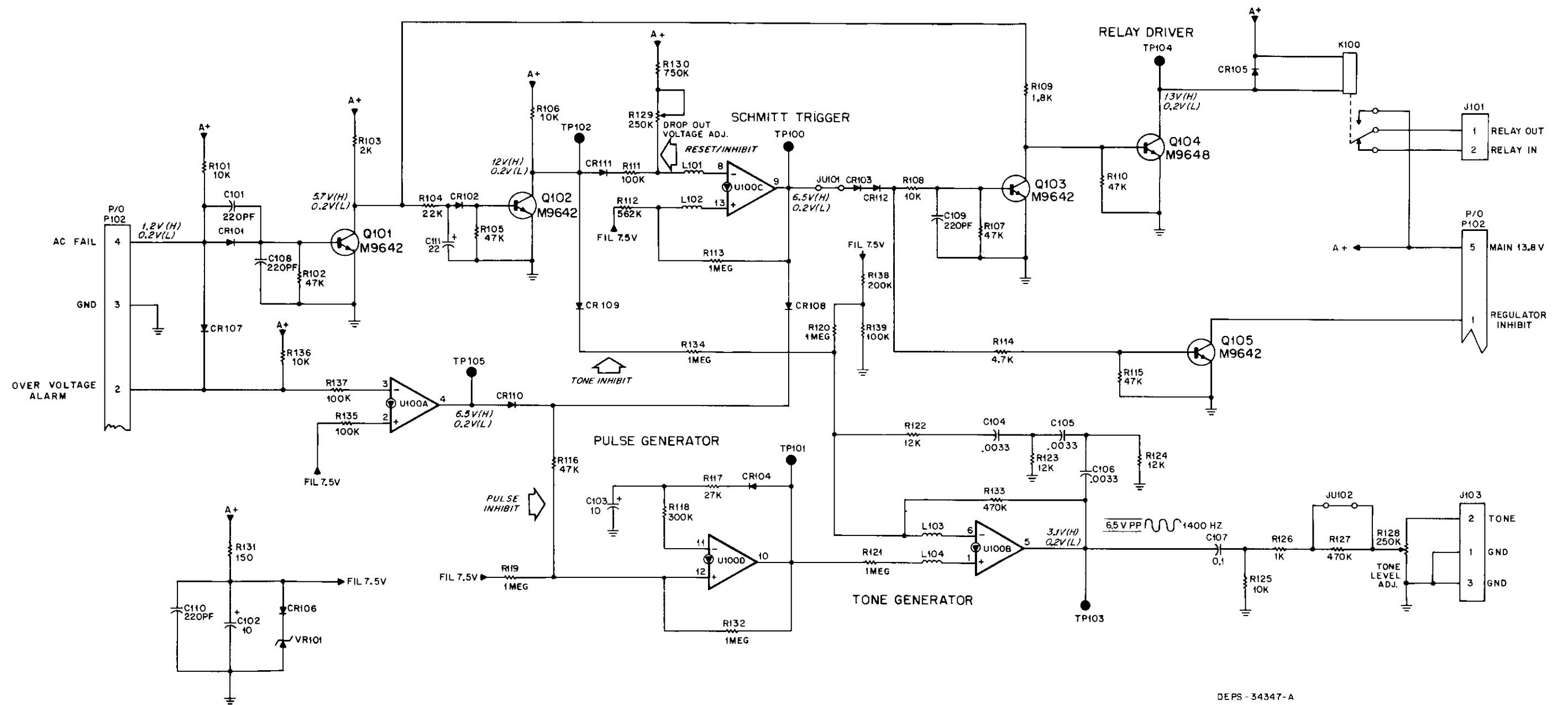

BATTERY CHARGER POWER SUPPLY

OPTION C28AN BATTERY CHARGER POWER SUPPLY

MODEL TPN1192A

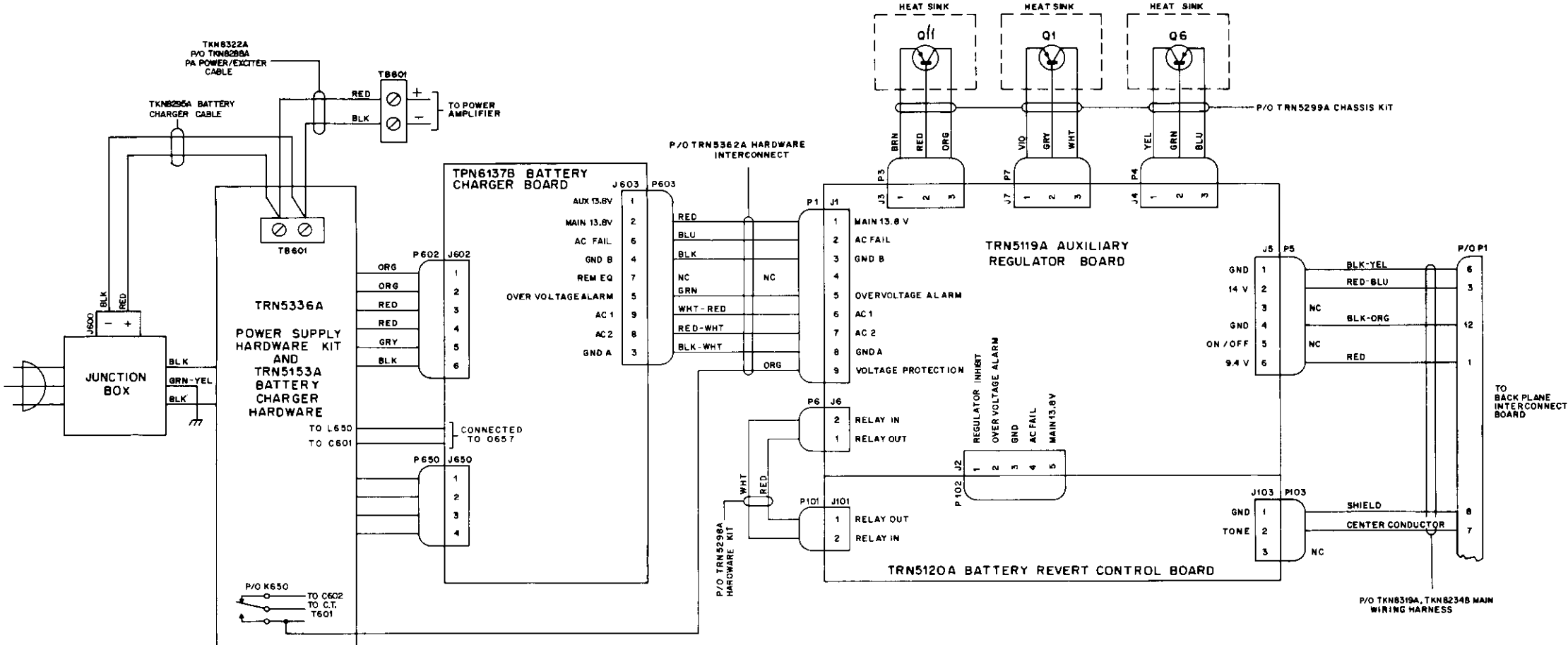

DEPS-34366-A



MOTOROLA INC.

Communications
Sector

DUPLEXER

MODEL TLD2502A
148-174 MHz

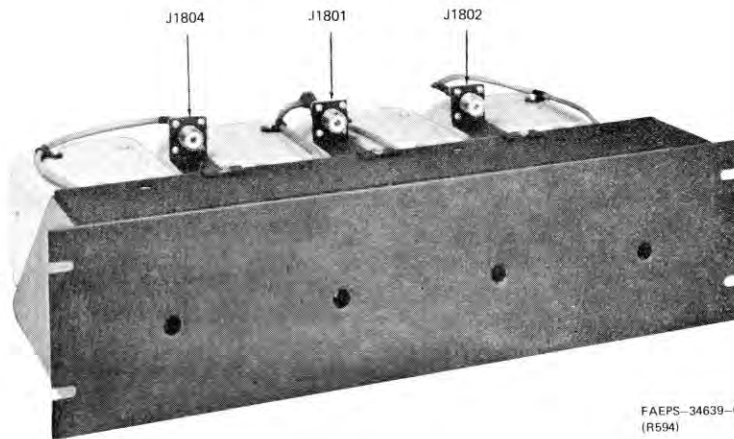

1. INTRODUCTION

This duplexer is for use with Motorola FM two-way radio communications equipment operating in the 148-174 MHz frequency range. It utilizes cavity resonators with a special internal loading construction to achieve a size much less than one-quarter wavelength. The resonators are tuned with an adjustable center conductor. The resonators use a unique temperature compensating mechanism and uniquely adjustable coupling loops. Specially designed low-profile cable connectors are used to obtain an extremely compact package.

This unit may be used in the antenna circuit of a base station or repeater to eliminate or minimize receiver desensitization or intermodulation from strong signals. Similarly, it may be used to reduce transmitter noise or intermodulation products.

PERFORMANCE SPECIFICATIONS

Model Number	TLD2502A
Insertion Loss	1.7 dB
Isolation at Transmit Frequency	82 dB
Isolation at Receiver Frequency	82 dB
Minimum Transmitter Receiver Isolation	52 dB
Minimum Frequency Separation	1.5 MHz
VSWR Maximum	1.5:1
Maximum Power Input	125 W
Temperature Range	-30 °C to +60 °C
Size	19" x 5-1/2" x 8-1/2"
Termination	N Female

SPECIFICATIONS SUBJECT TO CHANGE WITHOUT NOTICE

Model Complement

<i>TLD2502A Duplexer</i>	
TKN6471A	Cable (2 used)
TKN8292A	Cable, Antenna
TKN8293A	Cables, Receiver/Transmitter
TLD8392A	Cavity Filter (4 used)
TRN5445A	Hardware

DUPLEXER

technical writing services

2. INSTALLATION

Step 1. Carefully unpack the unit and check for concealed damage.

Step 2. The units are designed to mount on any standard 19-inch relay rack. Select position in rack for best location of unit, i.e., closest proximity to associated equipment inputs and outputs.

Step 3. Mount the unit in place in rack with appropriate mounting hardware. The hardware supplied is intended for use with Motorola base stations.

Step 4. Connect the duplexer to the transmitter and receiver. See Figure 4.

Step 5. The duplexer must be installed with appropriate lengths of 50-ohm coaxial cable (not supplied) to fit the individual installation.

3. THEORY OF OPERATION

Each resonant cavity, technically a reentrant quarter-wave resonator, is a very high Q (low loss) tunable tank circuit. A special internal construction uses two different characteristic impedances for the center conductor to achieve an overall length considerably less than a quarter-wavelength. The dimensions are designed for minimum loss. The cavities are tuned to the required pass frequency by an adjustment which changes the length of the center conductor. Lower frequencies have more of the center conductor inside the cavity, higher frequencies have correspondingly less. Special bimetal washers are used for temperature compensation to minimize detuning due to ambient temperature changes.

Each resonant cavity is fitted with a specially designed pair of coupling elements (loops). These loops efficiently convert energy from the 50-ohm coaxial cable to the correct mode inside the resonant structure. When the cavity is not tuned to resonance, most of the energy is reflected. Only a small portion is able to excite the correct mode and reach the output element.

The input and output coupling loops are placed very close to each other, to take advantage of mutual coupling. A small amount of energy is always being transferred between coupling loops because of their proximity. At one frequency, the energy transferred by mutual coupling cancels the energy transferred across by the resonant mode within the cavity. Thus, at one frequency, there is a reject notch in addition to the normal selectivity of the cavity. The proximity of the loops provides inductive coupling. An addition, a precision high Q trimmer capacitor is connected across the loops. This capacitor can adjust the net coupling to be inductive, the notch occurs above the pass frequency. When the net coupling is capacitive, the notch occurs below the pass frequency.

Cavities are used on each side of the duplexer. The cavities tuned to pass the lower frequency have the coupling loops tuned to notch out higher frequency, while the cavities tuned to pass the higher frequency have the coupling loops tuned to notch out the lower frequency. Quarter-wave coupling is used between cavities to obtain minimum pass band bandwidth and minimum insertion loss.

4. REMOVAL/REPLACEMENT OF COUPLING LOOPS

Coupling loops are factory-installed. If it becomes necessary to change coupling loops, refer to Figures 1, 2 and 5 and use the following procedure.

4.1 REMOVAL PROCEDURE

The cable shields are soldered to the connector portion of the loops. These shields must first be unsoldered before the loops can be removed. The shields cannot be attached to the cavity body because the cavity body acts as a heat sink.

Step 1. Remove the eight screws securing the connectors to the cavity body.

Step 2. The two coupling loops are internally connected and must be removed together. Using a 150-watt soldering iron, first unsolder and remove the connector covers from the two connectors.

Step 3. Grasp the center connector of the cable (at the point where it enters the center pin of the connector) with long nose pliers. Melt the solder around the cable shield and pull the cable off the connector. Do the same for the other connector.

Step 4. Remove the two knurled adjusting knobs taking care not to lose the washers. Now the loops are completely free and can be removed from the can.

Step 5. Maneuver both loops to the left so that the trimmer capacitor can fit through the left side of the hole and then remove the two loops together.

4.2 REPLACEMENT PROCEDURE

Step 1. Insert the loop assembly into the mounting holes and maneuver both loops to the left so that the trimmer capacitor will fit through the left side of the hole.

Step 2. Position the loops so that the tapped holes in the end of the loops are visible through the adjusting slots.

Step 3. Insert the knurled adjusting screw, along with the nylon and lock washers, into the tapped hole.

NOTE

The overall dimensions and the stripping of cables are critical, and it is therefore recommended that an entire cable kit be ordered using the correct TKN number (TKN6471A, TKN8292A or TKN8293A). The connector covers (Code No. 6) are included in the cable kit.

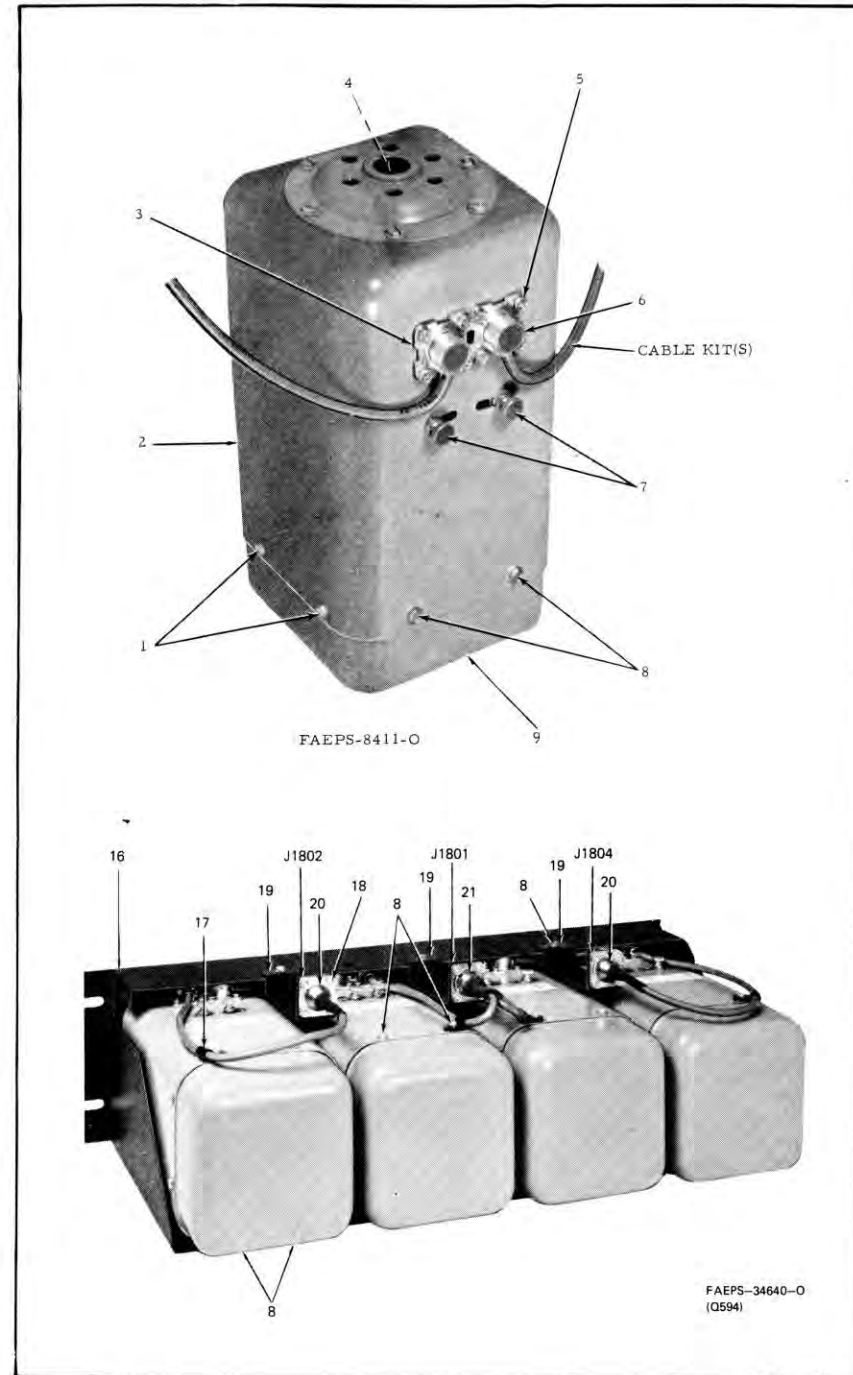

Figure 1. Cavity Filter Parts Location Detail

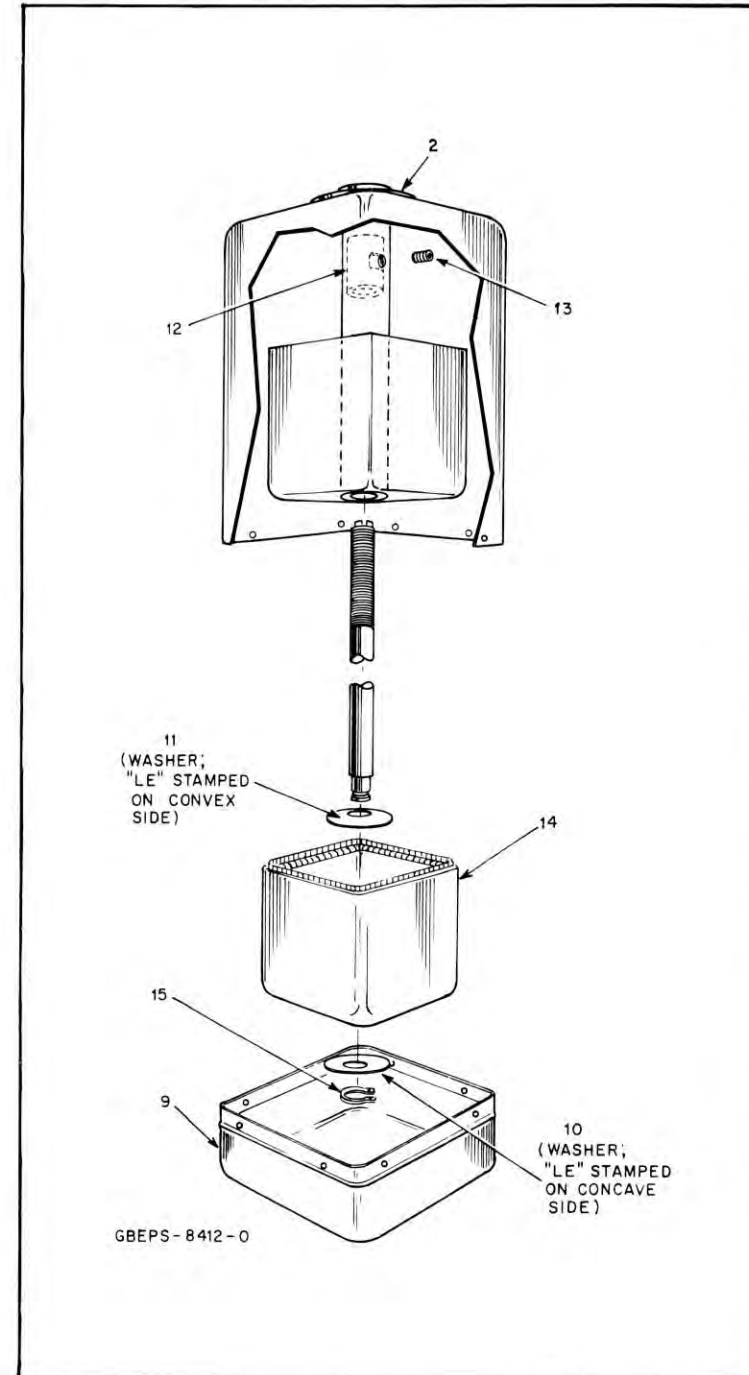

Figure 2. Cavity Internal Construction and Parts Location Detail

parts list

TLD8392A Cavity Filter PL-1677-A

REFERENCE SYMBOL	MOTOROLA PART NO.	DESCRIPTION
1	3-3375	SCREW, tapping; 6-20 x 5/16" plain hex head (4 req'd)
2	1-84312D01	CAVITY ASSEMBLY
3	1-80723B90	LOOP ASSEMBLY, coupling
4	47-84313D01	TUNING SHAFT
5	3-400356	SCREW, tapping; 4-32 x 1/4" Phillips hex head (8 req'd)
5	4-9777	LOCKWASHER, #4 split (8 used)
7	3-82245E04	SCREW, knurled head (2 req'd)
7	4-9746	LOCKWASHER, No. 8 med. split (2 req'd)
7	4-82418B01	WASHER, nylon (2 req'd)
9	15-84993C01	COVER, housing
10	4-84994C01	WASHER, temperature compensating ("LE" stamped on concave side)
11	4-84994C02	WASHER, temperature compensating ("LE" stamped on convex side)
12	1-84985C01	LOCKING NUT ASSEMBLY
13	3-7110	SCREW, set; 8-32 x 3/16" allen head
14	1-84314D01	TUNING CAN ASSEMBLY
15	42-824977	RING, truarc
—	33-84332B01	LABEL, nameplate

TKN8293A Cable Duplexer-Station PL-8047-O

REFERENCE SYMBOL	MOTOROLA PART NO.	DESCRIPTION
J1802,1804	9-82442E05	connector, receptacle: female; single contact
mechanical parts		
6	15-84002D01	COVER, connector; 2 used
18	2-131435	NUT, 4-40 x 1/4 x 3/32"; 8 used
18	3-1937	SCREW, machine; 4-40 x 5/16"; 8 used
18	4-114583	LOCKWASHER, #4 split; 8 used
19	7-83454N01	BRACKET, connector; 2 used
20	15-483599	HOOD, receptacle; 2 used

TKN6471A Cable Duplexer PL-8048-O

REFERENCE SYMBOL	MOTOROLA PART NO.	DESCRIPTION
6	15-84002D01	COVER, connector; 2 used

TRN5445A Hardware Mounting Duplexer PL-8049-O

REFERENCE SYMBOL	MOTOROLA PART NO.	DESCRIPTION
8	3-3398	SCREW, tapping; 6-20 x 5/16"; 19 used
—	3-83498N08	SCREW, tapping; black; M6 x 7.0 x 10; 4 used
16	27-82934N01	CHASSIS
17	42-82143C05	CLAMP, cable 3/16"; 4 used
—	66-82846D01	TOOL, tuning

TKN8292A Cable Duplexer-Antenna PL-8050-O

REFERENCE SYMBOL	MOTOROLA PART NO.	DESCRIPTION
J1801	9-82442E05	connector, receptacle: female; single contact
mechanical parts		
6	15-84002D01	COVER, connector; 2 used
18	2-131435	NUT, 4-40 x 1/4 x 3/32"; 4 used
18	3-1937	SCREW, machine; 4-40 x 5/16"; 4 used
18	4-114583	LOCKWASHER, #4 split; 4 used
19	7-83454N01	BRACKET, connector
21	15-82582H01	HOOD, receptacle

DUPLEXER

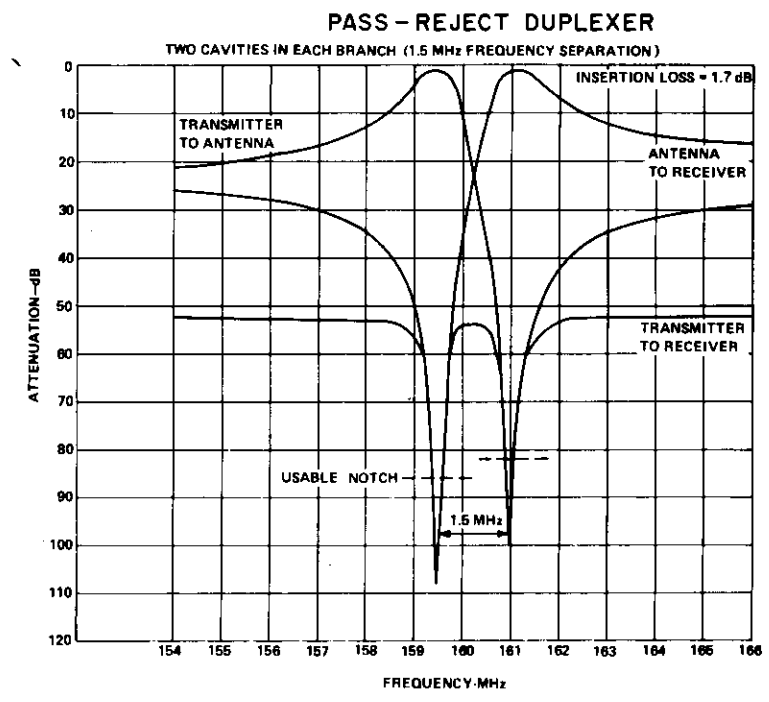
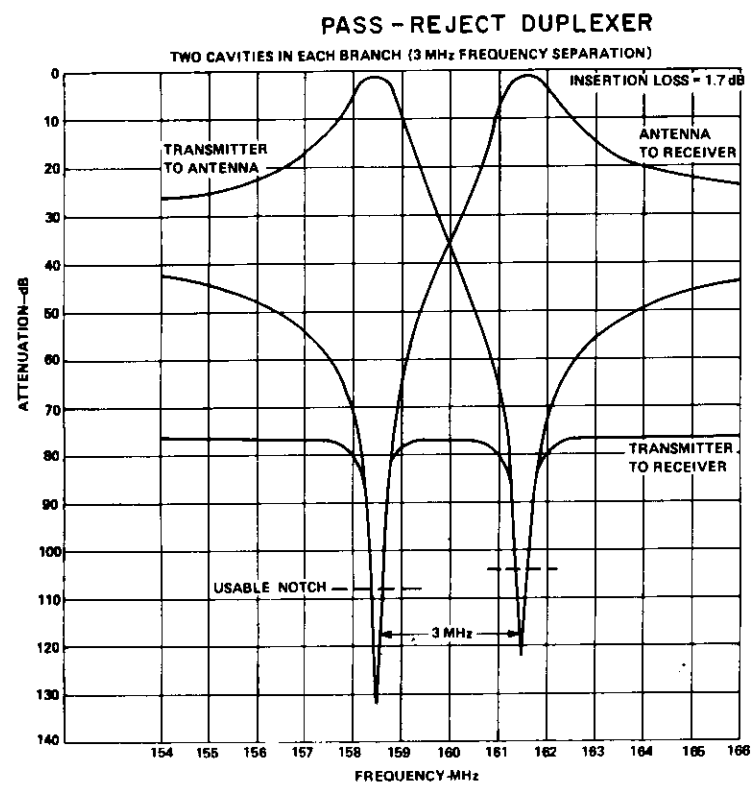

CEPS-34642-0

Figure 3. Duplexer Selectivity Curves

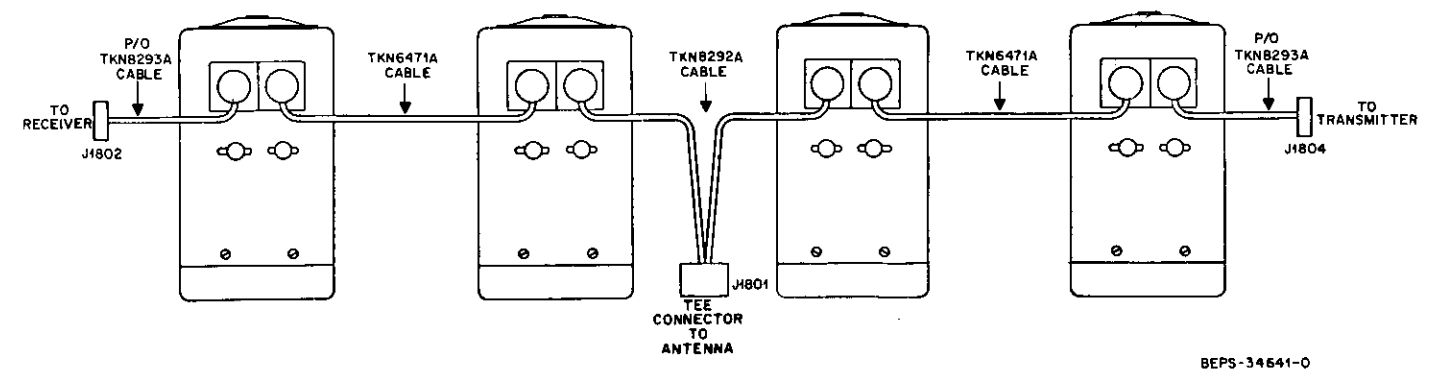

Figure 4. Duplexer Wiring Detail

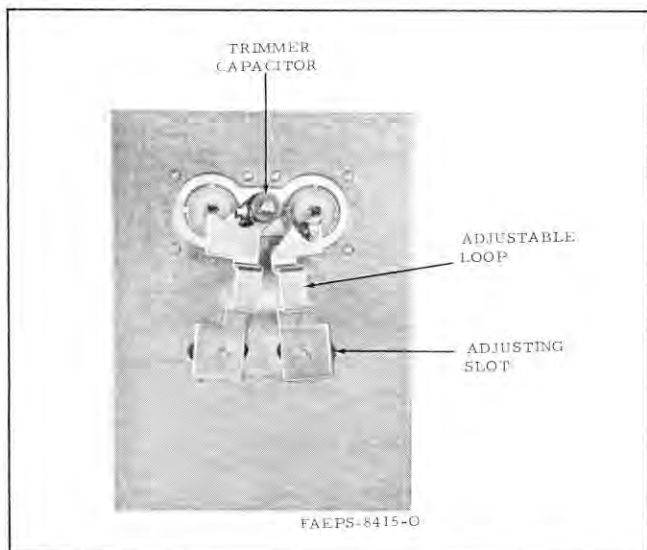

Figure 5. Coupling Loop (Interior View)

Step 4. Attach the connectors to the can using the eight self-tapping screws making certain that the connector cable slot is facing in the proper direction to insert the cable.

Step 5. Insert the cable into the connector cable slot while pressing the center conductor into the center pin of the connector.

Step 6. Place the connector cover over the connector and solder the cable shield and connector cover to the connector.

5. RECOMMENDED TUNING PROCEDURE

All duplexers are tuned to the customer-specified frequencies prior to shipment from the factory. If system performance indicates that the duplexer is detuned, one of the following procedures may be used. Do not attempt to retune unless the following procedures have been read and it is certain that performance does not meet specifications.

The following tuning procedures assume that the entire duplexer is to be retuned. If it is desired to perform a minor "touch-up", refer to paragraph 5.3 of this tuning procedure. When left and right are used in the following procedures, this shall mean facing the tuning shaft end and with the connectors facing up.

5.1 METHOD 1

5.1.1 Recommended Test Equipment

- Motorola R-2001 or R-1201 Signal Generator.
- Tunable receiver or two Motorola receivers, one tuned to each of the frequencies to be duplexed.

5.1.2 Tuning Procedure

Step 1. Move sliding screws as far apart as possible on each cavity and then tighten the screws.

Step 2. Turn trimmer capacitors fully counter-clockwise.

Step 3. Tune the signal generator and the receiver to the duplex receive frequency.

Step 4. Connect the signal generator to the antenna port and the receiver to the right-hand port.

Step 5. Tune the right-hand cavity(s) for minimum insertion loss by adjusting the tuning rod screw.

Step 6. Tune the signal generator and the receiver to the duplex transmit frequency.

Step 7. Connect the receiver to the left-hand port.

Step 8. Tune the left-hand cavity(s) for minimum insertion loss by adjusting the tuning rod screw.

Step 9. Connect the receiver to the right-hand port.

Step 10. Tune the right-hand cavity(s) for maximum attenuation by using procedure 5.4, "Tuning the Notch".

Step 11. Tune the signal generator and the receiver to the duplex receive frequency.

Step 12. Connect the receiver to the left-hand port.

Step 13. Tune the left-hand cavity(s) for maximum attenuation by using procedure 5.4.

Step 14. Repeat steps 3 through 13, but only tune the trimmer capacitors when tuning the notches.

5.2 METHOD 2

5.2.1 Recommended Test Equipment

- Mixer circuit constructed as shown in Figure 6.
- Motorola R-2001 or R1201 Signal Generator.
- I-F output from R1201 Series Signal Generator equal to the duplex frequency separation or a Motorola S1056B Portable Test Set with a crystal frequency equal to the duplex frequency separation.
- Motorola S1350A Wattmeter.
- Motorola T1013A RF Load Resistor.
- Isolated Tee connector (construct this by removing the Tee port center pin of a UHF Tee connector). This provides 30 to 40 dB of isolation between the shunt path and the direct path through the Tee to protect the receiver when the transmitter is keyed.

- Transmitter and receiver from the station to be duplexed.

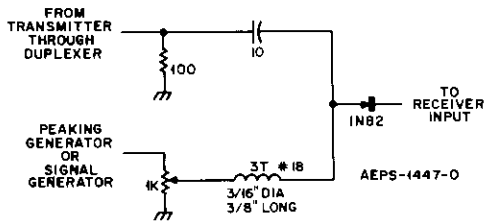

Figure 6. Mixer Circuit

5.2.2 Operation of the Mixer Circuit

Alignment of the duplexers can be simplified by using the mixer circuit shown in Figure 6. The mixer receives inputs from the transmitter and a low frequency source. The outputs from the mixer are frequencies above and below the transmitter frequency at separations equal to the output of the low frequency generator.

The receiver will respond to one of the mixer products and thus can be used indirectly to detect the transmitter frequency.

5.2.3 Tuning Procedure

- Step 1. Move sliding screws as far apart as possible on each cavity and then tighten the screws.
- Step 2. Turn trimmer capacitors fully counter-clockwise.
- Step 3. Connect the equipment as shown in Figure 7.

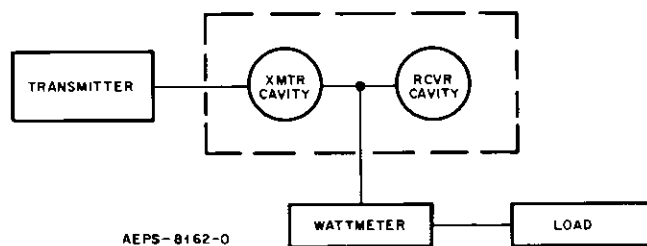

Figure 7. Method 2 Transmitter Branch Pass Test Set-Up

Step 4. Tune the left-hand cavity(s) for a maximum power reading on the wattmeter by adjusting the tuning rod screw.

Step 5. Connect the equipment as shown in Figure 8.

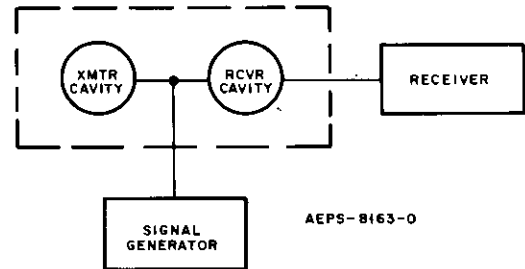

Figure 8. Method 2 Receiver Branch Pass Test Set-Up

Step 6. Tune the signal generator to the receive frequency.

Step 7. Tune the right-hand cavity(s) for a minimum insertion loss (maximum signal at the receiver) by adjusting the tuning rod screw.

Step 8. Connect the equipment as shown in Figure 9.

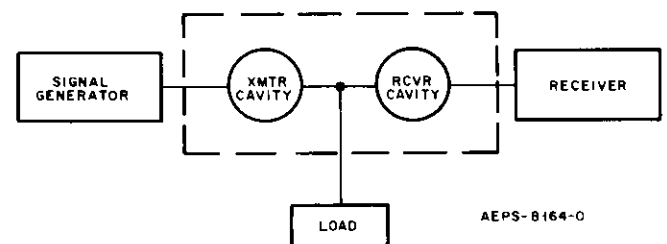

Figure 9. Method 2 Transmitter Branch Reject Test Set-Up

Step 9. Tune the left-hand cavity(s) for maximum attenuation by using procedure 5.4, "Tuning the Notch".

Step 10. Connect the equipment as shown in Figure 10.

Step 11. Set the local oscillator source to the exact duplex frequency separation.

Step 12. Tune the right-hand cavity(s) for maximum attenuation by using procedure 5.4.

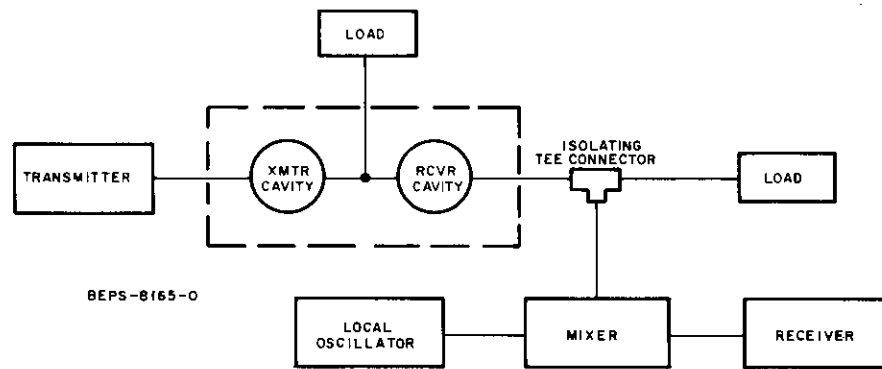

Figure 10. Method 2 Receiver Branch Reject Test Set-Up

Step 13. Repeat steps 3 through 12 but only tune the trimmer capacitors when tuning the notches.

Step 14. Connect the duplexer to the transmitter, receiver and antenna with 50-ohm coaxial cable. Adjust the transmitter final amplifier for rated power into the duplexer.

5.3 MINOR "TOUCH-UP" PROCEDURES

5.3.1 Method A

Step 1. Using the Recommended Test Equipment given in paragraph 5.1.1, tune the signal generator and the receiver to the duplex receive frequency.

Step 2. Connect the signal generator to the antenna port and the receiver to the right-hand port.

Step 3. Tune the right-hand cavity(s) for minimum insertion loss by adjusting the tuning rod screw.

Step 4. Tune the signal generator and the receiver to the duplex transmit frequency.

Step 5. Connect the receiver to the left-hand port.

Step 6. Tune the left-hand cavity(s) for minimum insertion loss by adjusting the tuning rod screw.

Step 7. Connect the receiver to the right-hand port.

Step 8. Tune the trimmer capacitor(s) on the right-hand cavity(s) for maximum attenuation.

Step 9. Tune the signal generator and the receiver to the duplex receive frequency.

Step 10. Connect the receiver to the left-hand port.

Step 11. Tune the trimmer capacitor(s) on the left-hand cavity(s) for maximum attenuation.

5.3.2 Method B

Step 1. Using the Recommended Test Equipment given in paragraph 5.2.1, connect the equipment as shown in Figure 7.

Step 2. Tune the left-hand cavity(s) for a maximum power reading on the wattmeter by adjusting the tuning rod screw.

Step 3. Connect the equipment as shown in Figure 8.

Step 4. Tune the signal generator to the receive frequency.

Step 5. Tune the right-hand cavity(s) for a minimum insertion loss (maximum signal at the receiver) by adjusting the tuning rod screw.

Step 6. Connect the equipment as shown in Figure 9.

Step 7. Tune the trimmer capacitor(s) on the left-hand cavity(s) for maximum attenuation.

Step 8. Connect the equipment as shown in Figure 10.

Step 9. Set the local oscillator source to the exact duplex frequency separation.

Step 10. Tune the trimmer capacitor(s) on the right-hand cavity(s) for maximum attenuation.

5.4 TUNING THE NOTCH

5.4.1 If the Notch (Reject) Frequency is Below the Pass Frequency:

Step 1. Move the sliding screws as far apart as possible and then tighten the screws.

Step 2. Tune the trimmer capacitor for maximum attenuation at the notch frequency.

5.4.2 If the Notch (Reject) Frequency is Above
the Pass Frequency:

Step 1. Turn the trimmer capacitor completely counterclockwise and then clockwise two full turns.

Step 2. Adjust the sliding screws for maximum attenuation at the notch frequency and then tighten the screws.

Step 3. Tune the trimmer capacitor for maximum attenuation at the notch frequency.



MOTOROLA INC.

Communications
Sector

2-RECEIVER COUPLER

MODEL TRD6270A
(EIA RACK INSTALLATIONS)

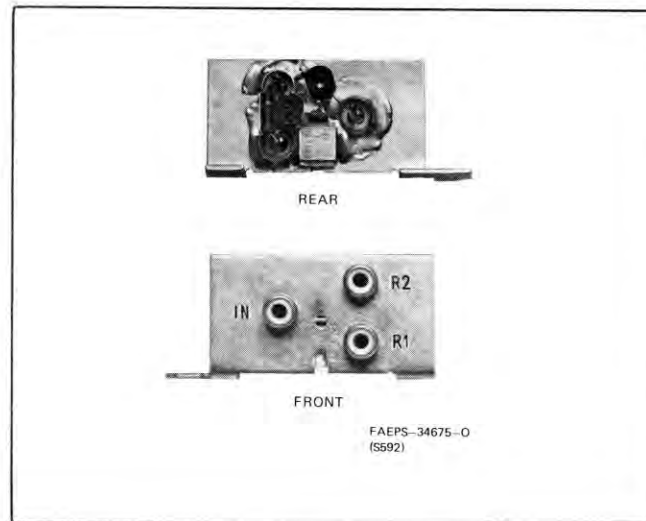

*Figure 1. 2-Receiver Coupler
Front and Rear View*

1. ELECTRICAL DESCRIPTION

This unit allows two receivers to operate from a single antenna source without interaction. It provides a correct impedance match between both receivers and the antenna source, and also provides isolation between the two receivers. Signal coupling and impedance matching is accomplished by utilizing two transformers and a resistor. A capacitor in the coupler partially cancels the circuit inductance and thereby makes the circuit appear resistive.

2. PHYSICAL DESCRIPTION

The 2-receiver coupler, consisting of a bracket which mounts the electrical components and three cable connectors, is mounted on a chassis installed in the base station. When the coupler is used, the input to the receiver is disconnected and reconnected to the IN connector on the coupler. Coupler cable W1 connects between the R1 coupler connector and the receiver module input connector J201. Coupler cable W2 connects between the R2 coupler connector and the second receiver module input connector J301.

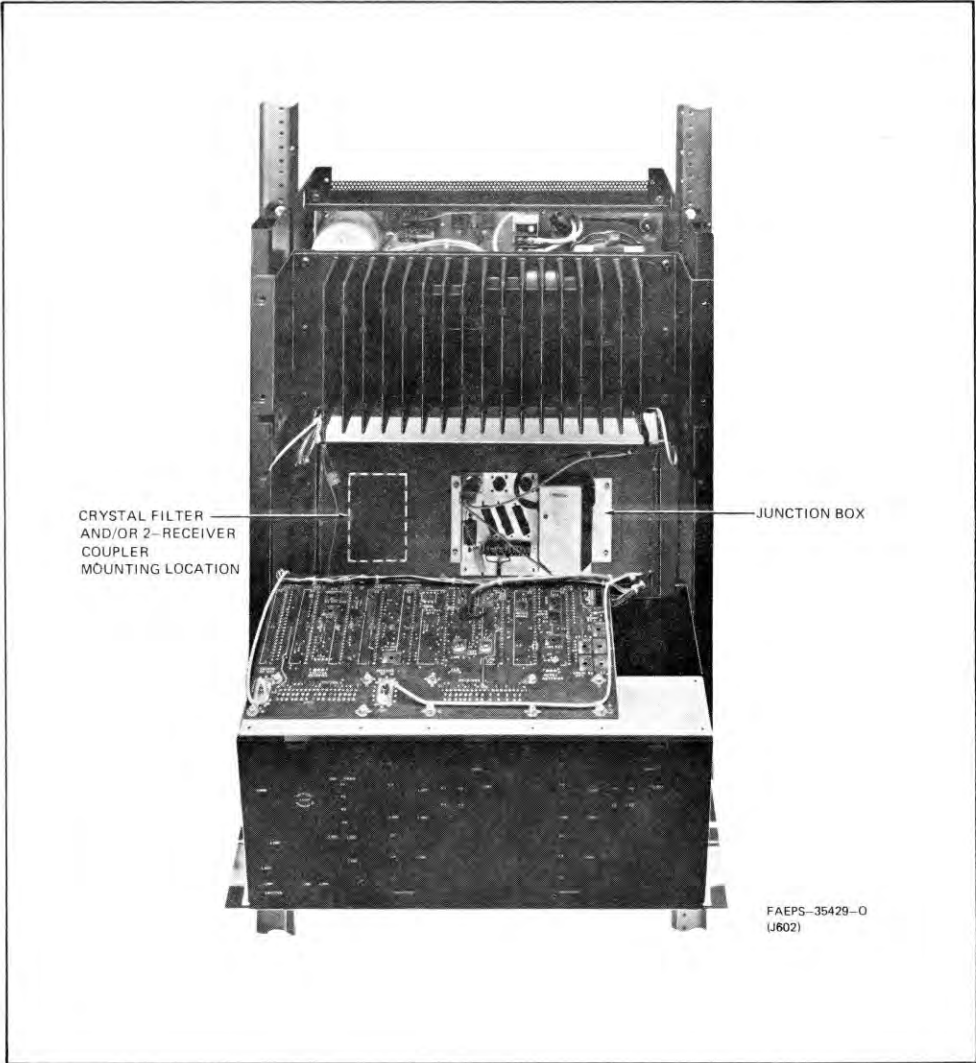

*Figure 2. 2-Receiver Coupler
Installed Location*

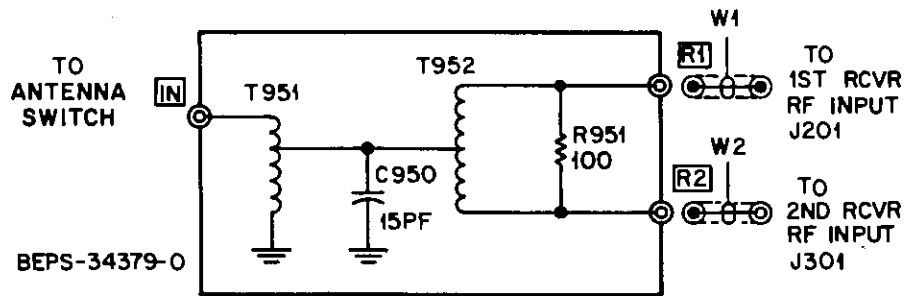

parts list

TRD6270A 2-Receiver Coupler

PL-8276-A

REFERENCE SYMBOL	MOTOROLA PART NO.	DESCRIPTION
C950	21-82785H57	capacitor, fixed: 15 pF \pm 0.5 pF; 850 V
R951	6-125A25	resistor, fixed: 100 \pm 5%; 1/2 W
T951	24-84130G02	transformer: splitter
T952	24-84130G01	transformer: splitter
W1	1-80783D70 30-83794C01 28-82331G01 28-82875N01	cable assembly: includes: CABLE, coaxial; 45" long CONNECTOR, plug; single contact type PLUG, board mount; phono type
W2	1-80783D71 30-83794C01 28-82875N01 28-82331G01	cable assembly: includes: CABLE, coaxial; 40" long PLUG, board mount; phono type CONNECTOR, plug; single contact type
non-referenced items		
	1-80737B78	ASSEMBLY, splitter board
	2-131435	NUT, 4-40 x 1/4"; 2 used
	3-134186	SCREW, thread forming: 6-32 x 5/16"; 2 used
	3-135500	SCREW, machine: 4-40 x 1/4"; 2 used
	7-83020N01	BRACKET, coupler
	42-10217A02	STRAP, tie; 6 used
	42-82143C05	CLIP, cable
	42-82143C08	CLIP, cable
	42-82143C08	CLIP, cable; 2 used
	3-135841	SCREW, thread forming: 6-32 x 7/8"; 2 used
	2-121841	NUT, locking: 6-32; 2 used
	73-848	SPACER, 7/16; 2 used

2-Receiver Coupler (EIA Rack Installation)
Schematic Diagram & Parts List
Motorola No. PEPS-35459-A

1/14/83 - V & G



MOTOROLA INC.

Communications
Sector

2-RECEIVER COUPLER

MODEL TRD6210A

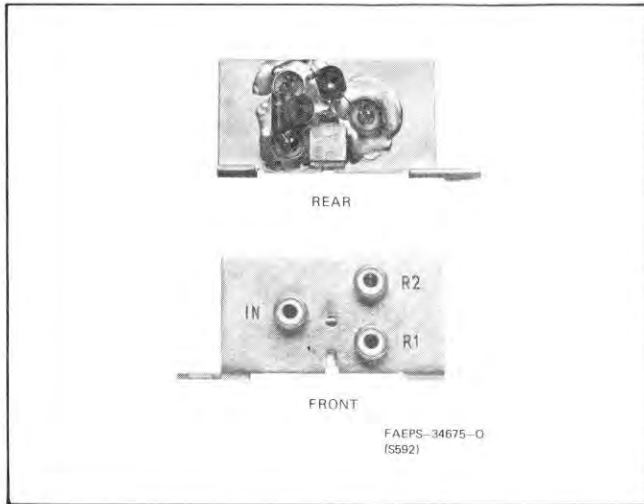

Figure 1. 2-Receiver Coupler
Front and Rear View

1. ELECTRICAL DESCRIPTION

This unit allows two receivers to operate from a single antenna source without interaction. It provides a correct impedance match between both receivers and the antenna source, and also provides isolation between the two receivers. Signal coupling and impedance matching is accomplished by utilizing two transformers and a resistor. A capacitor in the coupler partially cancels the circuit inductance and thereby makes the circuit appear resistive.

2. PHYSICAL DESCRIPTION

The 2-receiver coupler, consisting of a bracket which mounts the electrical components and three cable connectors, is mounted on a chassis installed in the base

station. When the coupler is used, the input to the receiver is disconnected and reconnected to the IN connector on the coupler. Coupler cable W1 connects between the R1 coupler connector and the receiver module input connector J201. Coupler cable W2 connects between the R2 coupler connector and the second receiver module input connector J301.

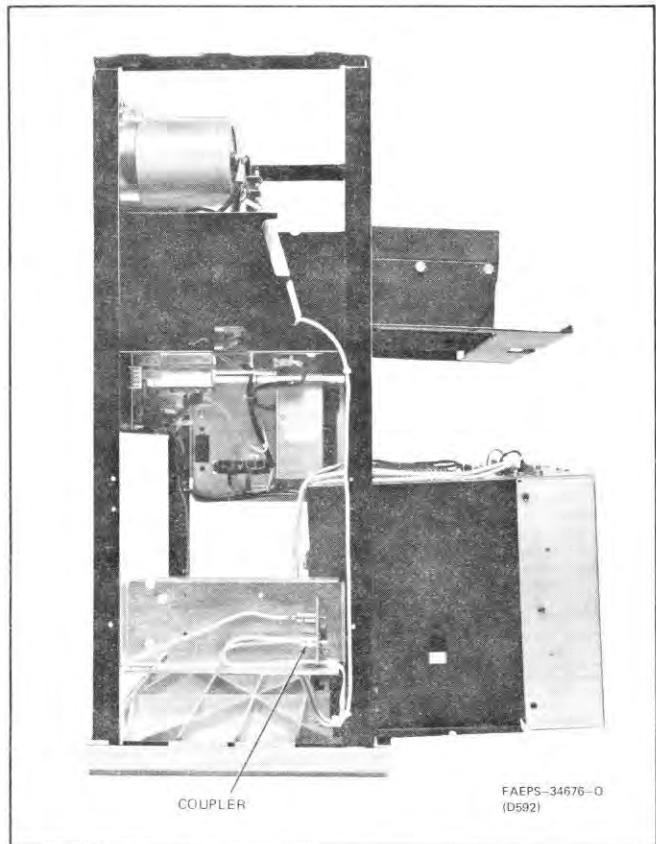
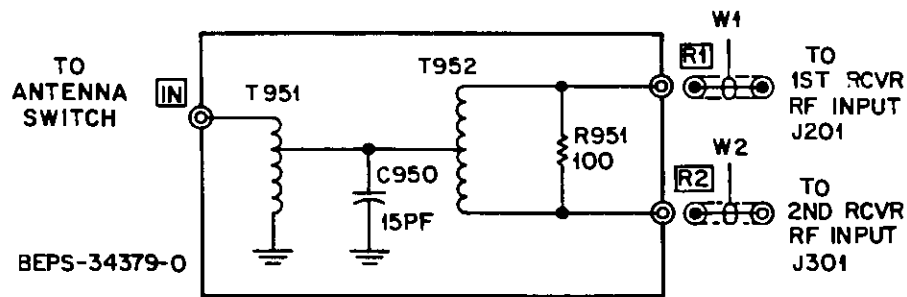

Figure 2. 2-Receiver Coupler
Installed Location

2-RECEIVER COUPLER

technical writing services



parts list

TRD6210A 2-Receiver Coupler

PL-8008-O

REFERENCE SYMBOL	MOTOROLA PART NO.	DESCRIPTION
C950	21-82785H57	capacitor, fixed: 15 pF \pm 0.5 pF; 850 V
R951	6-125A25	resistor, fixed: 100 \pm 5%; 1/2 W
T951	24-84130G02	transformer: splitter
T952	24-84130G01	splitter
W1	1-80736D03 30-83794C01 28-82331G01 28-82875N01	cable assembly: includes: CABLE, coaxial; 31" long CONNECTOR, plug; single contact type PLUG, board mount; phono type
W2	1-80736D04 30-83794C01 28-82785N01 28-82331G01	includes: CABLE, coaxial; 37.5" long PLUG, board mount; phono type CONNECTOR, plug; single contact type
non-referenced items		
	1-80737B78	ASSEMBLY, splitter board
	2-131435	NUT, 4-40 x 1/4"; 2 used
	3-134186	SCREW, tapping; 6-32 x 5/16"; 2 used
	3-82227A03	SCREW, machine; 4-40 x 5/16"; 2 used
	7-83020N01	BRACKET, coupler
	42-10217A02	STRAP, tie; 7 used
	42-82143C05	CLIP, cable
	42-82143C08	CLIP, cable
	42-82143C09	CLIP, cable; 3 used

2-Receiver Coupler
Schematic Diagram & Parts List
Motorola No. PEPS-34638-O
7/12/82 - V & G



MOTOROLA INC.
 Communications
 Sector

MSR 2000 BASE STATION SERVICE ACCESSORIES

TRN5080A DC METERING CHASSIS
 TRN5079A SERVICE INTERCOM
 WITH SPEAKER CHASSIS



Figure 1. TRN5080A DC Metering Chassis

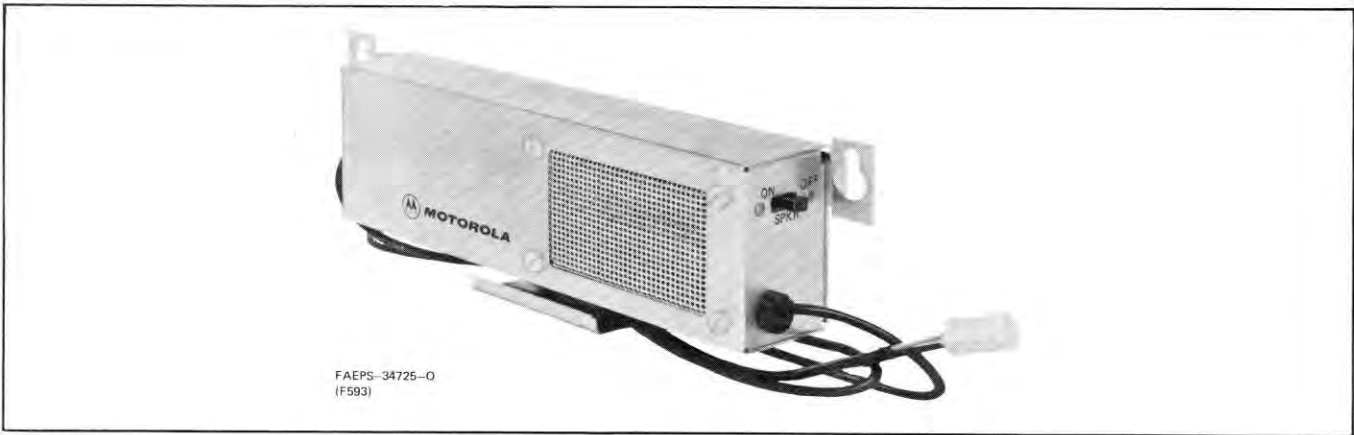

Figure 2. TRN5079A Service Intercom with Speaker Chassis

1. DESCRIPTION

1.1 The TRN5079A Service Intercom with Speaker Chassis provides a local audio speaker for use in troubleshooting the station, and for intercom use when the station is provided with the intercom option. The TRN5080A DC Metering Chassis provides the same local speaker, and in addition, provides most station metering required for normal servicing and maintenance.

1.2 The meter is a 0-50 uA instrument mounted on the dc metering chassis. A selector switch chooses the specific function to be metered. Every function available at the metering receptacle of the exciter, power amplifier/power control board, and receiver board(s) can be selected for metering. The dc metering chassis is equipped with a connection cable terminated with the standard Motorola 7-pin metering connector, which may be connected to the metering connectors provided in the station.

MSR 2000 BASE STATION SERVICE ACCESSORIES

technical writing services

1301 E. Algonquin Road, Schaumburg, IL 60196

CAUTION

The TRN5080A DC Metering Chassis must not be connected to control metering connector J2 on the backplane interconnect board. (This connector may be labeled either TEST SET MTR or CONTROL MTR, depending on station model.) Damage to the metering circuit will result. The control metering connector is intended for connection to the Motorola TEK-5 Metering Panel or the S1056-59 Portable Test Set only.

2. OPERATING INSTRUCTIONS

2.1 LOCAL SPEAKER

Press the two-conductor speaker connector onto pins 22 and 23 of the receiver 1 audio board position on the back of the station backplane interconnect board. This connection may be left permanently if desired. The speaker is switched on or off as desired, by changing the position of the SPKR-switch.

2.2 METERING

Step 1. Connect the metering connector from the dc metering chassis to the desired metering connector in the station. In the Motorola *MSR 2000* station, exciter and receiver metering connectors are both located on the backplane interconnect board. The power amplifier/power control metering connector is located on the power control board. See Caution.

Step 2. Select the meter position required. If the meter deflects in the wrong direction, change the position of the FWD-REV switch.

NOTE

Refer to the Transmitter and Receiver sections of the station manual for typical meter readings. Also, keep a log of all meter readings each time the station is serviced. Use the last set of readings as a reference, note any degradation of performance.

Meter Polarity Switch Position

Board Metered	Position
Receiver	FWD
Exciter	REV
PA/Power Control	FWD

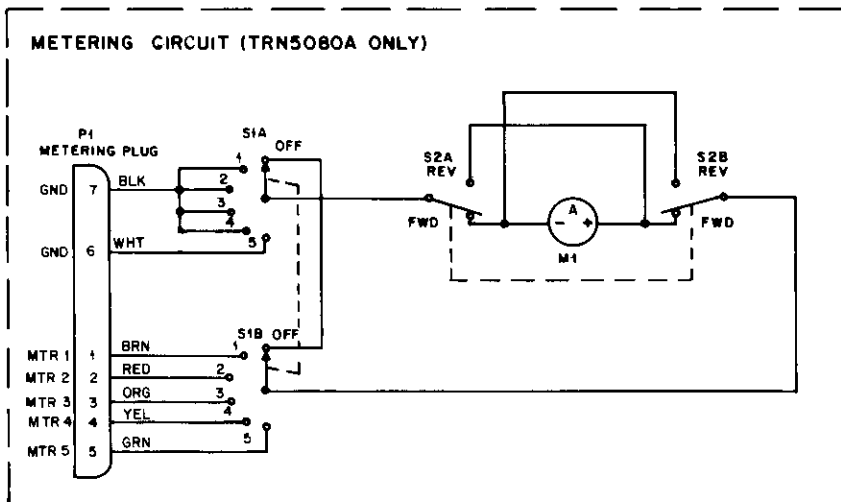

P1 DETAIL

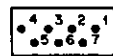

SHOWN FROM PIN END

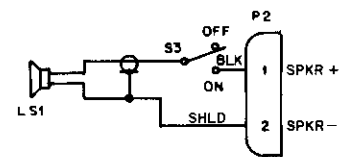

BEPS-34726-0

P2 DETAIL



SHOWN FROM PIN END

parts list

TRN5079A Service Intercom With Speaker Chassis
 TRN5080A DC Metering Chassis

PL-8037-O

REFERENCE SYMBOL	MOTOROLA PART NO.	DESCRIPTION
LS1	50-82913N01	speaker: 8 ohms; 1-3/4 x 3"
M1	72-83319G01	meter: 50 uA (TRN5080A)
P1	28-84208B01	connector, plug: male, 7-contact (TRN5080A) housing; 2-position
P2	15-83498F38	
S1	40-82924N01	switch: rotary (TRN5080A) slide, dpdt
S2, 3	40-83204B01	
mechanical parts		
	3-124616	SCREW, tapping; 6-32 x 1/4"; 2 used
	3-136934	SCREW, tapping; 6-32 x 3/8"; 2 used (TRN5080A)
	15-82927N01	COVER
	35-82928N01	GRILLE
	36-82929N01	KNOB (TRN5080A)
	42-850861	RETAINER, cable (TRN5080A)
	42-82018H07	RETAINER, cable
	29-83499F01	TERMINAL; 2 used
	30-824275	CABLE, shielded; 42" used
	15-82926N01	HOUSING (TRN5080A)
	3-129674	SCREW, machine; 4-40 x 3/16"; 2 used (TRN5080A)
	3-132341	SCREW, machine; 4-36 x 1/4"; 2 used (TRN5080A)
	15-83947K01	COVER; 2 used (TRN5080A)
	30-83678K01	CABLE, 7-conductor; 42" used (TRN5080A)
	42-83948K01	CLIP; 2 used (TRN5080A)
	15-82928N02	HOUSING (TRN5079A)
	5-10281A05	RIVET; 4 used



MSR 2000™ BASE (RA), REPEATER (RA), & GUARD TONE KEYING CONFIGURATIONS

OPTION C150, C160, AND C170 SERIES

1. DESCRIPTION AND APPLICATION

1.1 INTRODUCTION

1.1.1 The options described in this instruction section are designed to provide for the remote control of a base station which, because of its location, cannot be economically connected via a wire line pair to the control point. Mountain top sites or locations in uninhabited regions (where no telephone lines exist) are typical examples of base station sites which need to be controlled using specialized radio equipment instead of a wire line pair.

1.1.2 By definition, an "RA" link (part of a "radio repeater (RA) system") is the radio equipment required to replace the usual wire-line control when operating a remote base station from its control point. The remote base station is termed an RA base. The repeater station that controls the RA base is called an RA repeater. It is co-located with the RA base and interconnected by a single, multi-conductor cable (customer supplied). A console and/or control station is located where the normal dispatch operations are carried out. See Figures 1 and 2.

1.1.3 RA links usually operate on 72 MHz, 450 MHz, or 960 MHz. Within the United States, the Federal Communications Commission (FCC) has certain restrictions making it difficult to license a 72 MHz RA link within 80 miles of a channel 4 or 5 TV station, or a UHF RA link within 75 to 100 miles of a metropolitan area with a population 200,000 or more.

1.2 BASE (RA) OPTION C150

1.2.1 The base (RA) option C150 can be used with all MSR 2000, single receiver, dc or tone remote control base station models in the 132-174 MHz, or 450-512 MHz frequency bands. The base (RA) option cannot be used with repeater (RT) models.

1.2.2 The MSR 2000 base (RA) station may be connected to an RA link made up of MICOR stations. Refer to the Interconnect Diagrams provided at the end of this section.

1.2.3 The base (RA) option adds a squelch gate module which keys the companion repeater (RA) station when a message is received at the base (RA) station. The squelch gate module provides a PTT function

MSR 2000 and Micor are trademarks of Motorola, Inc.

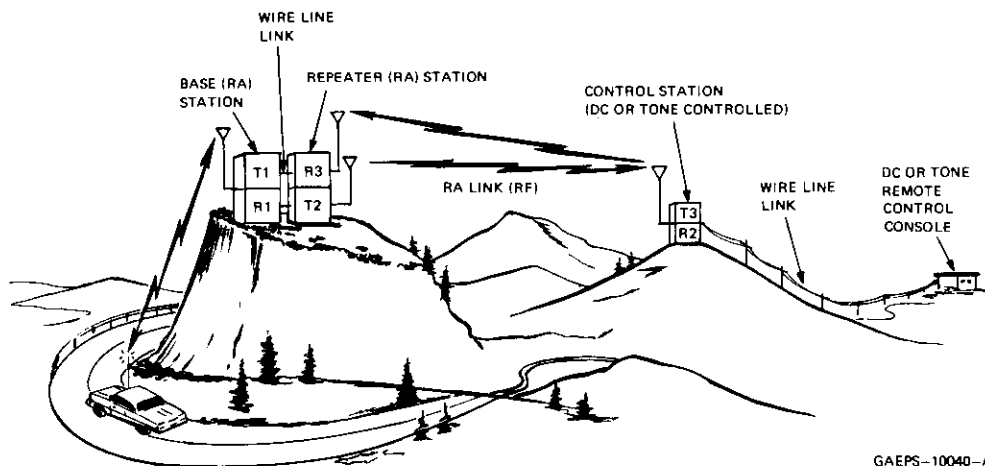

Figure 1. Typical Repeater (RA) System

OPTION C150, C160, AND C170 SERIES

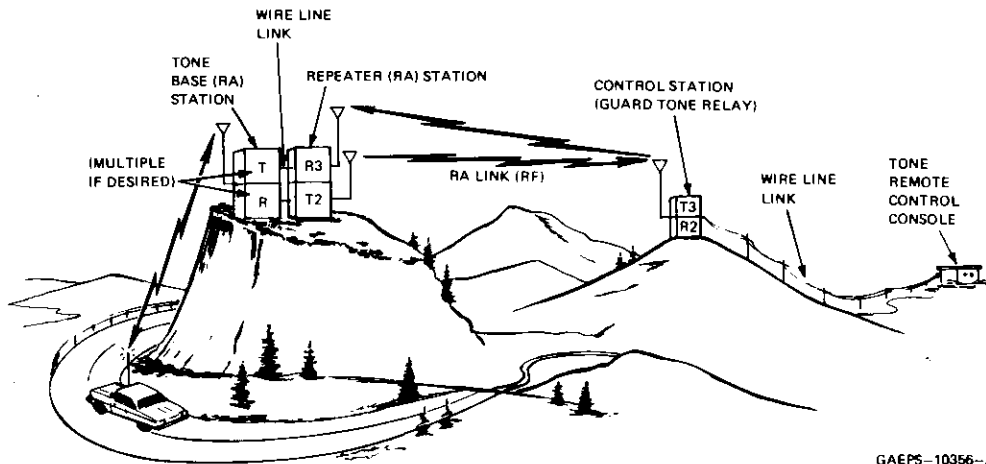

Figure 2. Typical Guard Tone Relay System

(switched ground) to the repeater (RA) station when the receiver in the base (RA) station quiets (receives a message).

1.2.4 When the station is converted for base (RA) operation, separate wire-line remote control is not required. Control is via rf from the control dispatch point or mobile with the control point given priority. This does not involve further model complement change concerning tone remote control models, but does remove the dc transfer module in dc remote control models.

1.2.5 RA link equipment (Base (RA)-Repeater (RA) stations) is used in two basic systems — “Repeater (RA) Systems” and “Guard Tone Relay Systems.” Both systems are used where extended range operation is required, or where natural or man made limitations to direct communications are encountered.

1.3 REPEATER (RA) OPTION C160

1.3.1 The repeater (RA) option C160 may be used with either *MSR 2000* or Micor™ 450-512 MHz repeater (RT) models (PL or carrier squelch). Note that either a duplexer or separate receive and transmit antennas are required on an RA repeater station to satisfy FCC rules and regulations for dispatcher priority.

1.3.2 A repeater (RA) station in conjunction with a base (RA) station and two or more remote stations, such as a mobile station and a control station, together form a “radio repeater (RA) system”. See Figure 1.

1.3.3 The repeater (RA) - base (RA) combination has two modes of operation. It can: (1) receive and re-transmit a message from a control station to a mobile station; and, (2) receive and re-transmit a message from a mobile station to a control station.

1.3.4 The mobile units and the base (RA) station operate on frequency F1. The repeater (RA) station transmits on frequency T2 and receives on frequency R3. The control station transmits on frequency T3 and receives on frequency R2.

1.3.5 When the control station calls the mobile unit, the repeater (RA) turns on the base (RA) station transmitter. When receiver quieting of the repeater (RA) station reaches a predetermined level, the squelch gate in the repeater (RA) station actuates. This keys the transmitter in the base (RA) station. Audio is routed from the repeater (RA) station’s receiver to the base (RA) station’s transmitter audio input. The control station (dispatcher’s) message is then sent to the mobile units on frequency T1 by the base (RA) station’s transmitter.

1.3.6 When a mobile station calls the control station (dispatcher), the base (RA) station turns on the repeater (RA) station’s transmitter. (When receiver quieting of the base (RA) stations reaches a predetermined level, the squelch gate in the base (RA) station actuates. This keys the transmitter in the repeater (RA) station.) Audio is routed from the base (RA) station’s receiver to the repeater (RA) station’s transmitter audio input. The mobile station’s message is then sent to the control station on frequency T2 by the repeater (RA) station’s transmitter.

1.3.7 The control station has operational priority of the base (RA) station. The dispatcher can seize control of the RA system even through a mobile transmission is in process. The control station transmits on T3. Repeater (RA) receiver (R3) is always fully operational, and will, when its receiver quieting reaches a predetermined level, cause the base (RA) station to key, over-riding the mobile.

1.4 GUARD TONE RELAY OPTION C170

1.4.1 A guard tone relay system is much like the usual "RA" system -- with greatly expanded control capability.

1.4.2 In the repeater (RA) system (refer to Figure 1) a received message at the repeater (RA) station actuates the squelch gate in that station. This keys the companion base (RA) station which retransmits the message to mobile units. Only transmitter turn-on and turn-off control of the base (RA) station is possible in a repeater (RA) system, determined by receiver quieting and the squelch gate module in the repeater (RA) station.

1.4.3 In the guard tone relay system (see to Figure 2), the presence of an rf signal *alone* at the repeater (RA) station does NOT cause the companion station to transmit. Instead, the companion station is controlled via tone signals, just as if it were connected directly to a remote control console by wire lines. This permits multiple frequency operation, PL disable (PL or DPL coded squelch models), unique function commands, etc., of the companion base (RA) station.

1.4.4 For example, should the tone remote control console operator (dispatcher) want to talk to a mobile unit on frequency T4, a high level guard tone signal burst is applied to the control station. The control station keys *immediately* on frequency T3 and transmits the remaining *guard tone* signal to the repeater (RA) station. The repeater (RA) station applies this high level guard tone signal to the audio input of the companion tone remote control base (RA) station, which is then ready to accept and react to the forthcoming T4 function tone. The flexibility and number of functions in the guard tone relay system is limited only by the sophistica-

tion of the companion tone remote control base (RA) station and the remote control console. It should be noted that a squelch gate is used in the repeater (RA) station in this guard tone application to provide a transmitter channel element ground when the station is keyed. This is necessary since neither an F1-CS (carrier squelch) or F1-PL control module is used, which would otherwise supply the ground. The squelch gate is NOT used to key the companion base (RA) station.

NOTE

The transmit time of the high level guard tone burst sent by the remote control console should be lengthened to compensate for the delay time encountered in the keying of the guard tone relay station. Refer to the tone remote control console instruction manual for details.

2. CONNECTIONS BETWEEN BASE (RA) AND REPEATER (RA) STATIONS

The base (RA) station is connected to a companion repeater (RA) station via a single, multi-conductor cable (customer supplied). Since the cable is normally short and within the same installation site room, the usual telephone company line restrictions do not apply; adjust audio levels at +14 dBm. Control functions are also carried by direct connections. Connect the base (RA) station to the companion repeater (RA) station. Refer to Interconnect Diagrams provided at the end of this section.

NOTE

Antenna and power connections are not changed by the use of the base (RA) conversion.

**COMMERCIAL WARRANTY
(STANDARD)**

Motorola radio communications products are warranted to be free from defects in material and workmanship for a period of ONE (1) YEAR, (except for crystals and channel elements which are warranted for a period of ten (10) years) from the date of shipment. Parts, including crystals and channel elements, will be replaced free of charge for the full warranty period but the labor to replace defective parts will only be provided for One Hundred-Twenty (120) days from the date of shipment. Thereafter purchaser must pay for the labor involved in repairing the product or replacing the parts at the prevailing rates together with any transportation charges to or from the place where warranty service is provided. This express warranty is extended by Motorola Communications and Electronics, Inc., 1301 E. Algonquin Road, Schaumburg, Illinois 60196, to the original purchaser only, and only to those purchasing for purpose of leasing or solely for commercial, industrial, or governmental use.

THIS WARRANTY IS GIVEN IN LIEU OF ALL OTHER WARRANTIES EXPRESS OR IMPLIED WHICH ARE SPECIFICALLY EXCLUDED, INCLUDING WARRANTIES OF MERCHANTABILITY OR FITNESS FOR A PARTICULAR PURPOSE. IN NO EVENT SHALL MOTOROLA BE LIABLE FOR INCIDENTAL OR CONSEQUENTIAL DAMAGES TO THE FULL EXTENT SUCH MAY BE DISCLAIMED BY LAW.

In the event of a defect, malfunction or failure to conform to specifications established by seller, or if appropriate, to specifications accepted by Seller in writing, during the period shown, Motorola, at its option, will either repair or replace the product or refund the purchase price thereof, and such action on the part of Motorola shall be the full extent of Motorola's liability hereunder.

This warranty is void if:

- a. the product is used in other than its normal and customary manner;
- b. the product has been subject to misuse, accident, neglect or damage;
- c. unauthorized alterations or repairs have been made, or unapproved parts used in the equipment.

This warranty extends only to individual products, batteries are excluded, but carry their own separate limited warranty. Because each radio system is unique, Motorola disclaims liability for range, coverage, or operation of the system as a whole under this warranty except by a separate written agreement signed by an officer of Motorola.

Non-Motorola manufactured products are excluded from this warranty, but subject to the warranty provided by their manufacturers, a copy of which will be supplied to you on specific written request.

In order to obtain performance of this warranty, purchaser must contact its Motorola salesperson or Motorola at the address first above shown, attention Quality Assurance Department.

This warranty applies only within the United States.

EPS-27734-O

COMPUTER SOFTWARE COPYRIGHTS

The Motorola products described in this instruction manual may include copyrighted Motorola computer programs stored in semiconductor memories or other media. Laws in the United States and other countries preserve for Motorola certain exclusive rights for copyrighted computer programs, including the exclusive right to copy or reproduce in any form the copyrighted computer program. Accordingly, any copyrighted Motorola computer programs contained in the Motorola products described in this instruction manual may not be copied or reproduced in any manner without the express written permission of Motorola. Furthermore, the purchase of Motorola products shall not be deemed to grant either directly or by implication, estoppel, or otherwise, any license under the copyrights, patents or patent applications of Motorola, except for the normal non-exclusive, royalty free license to use that arises by operation of law in the sale of a product.

EPS-34440-B

68P81112E94-B

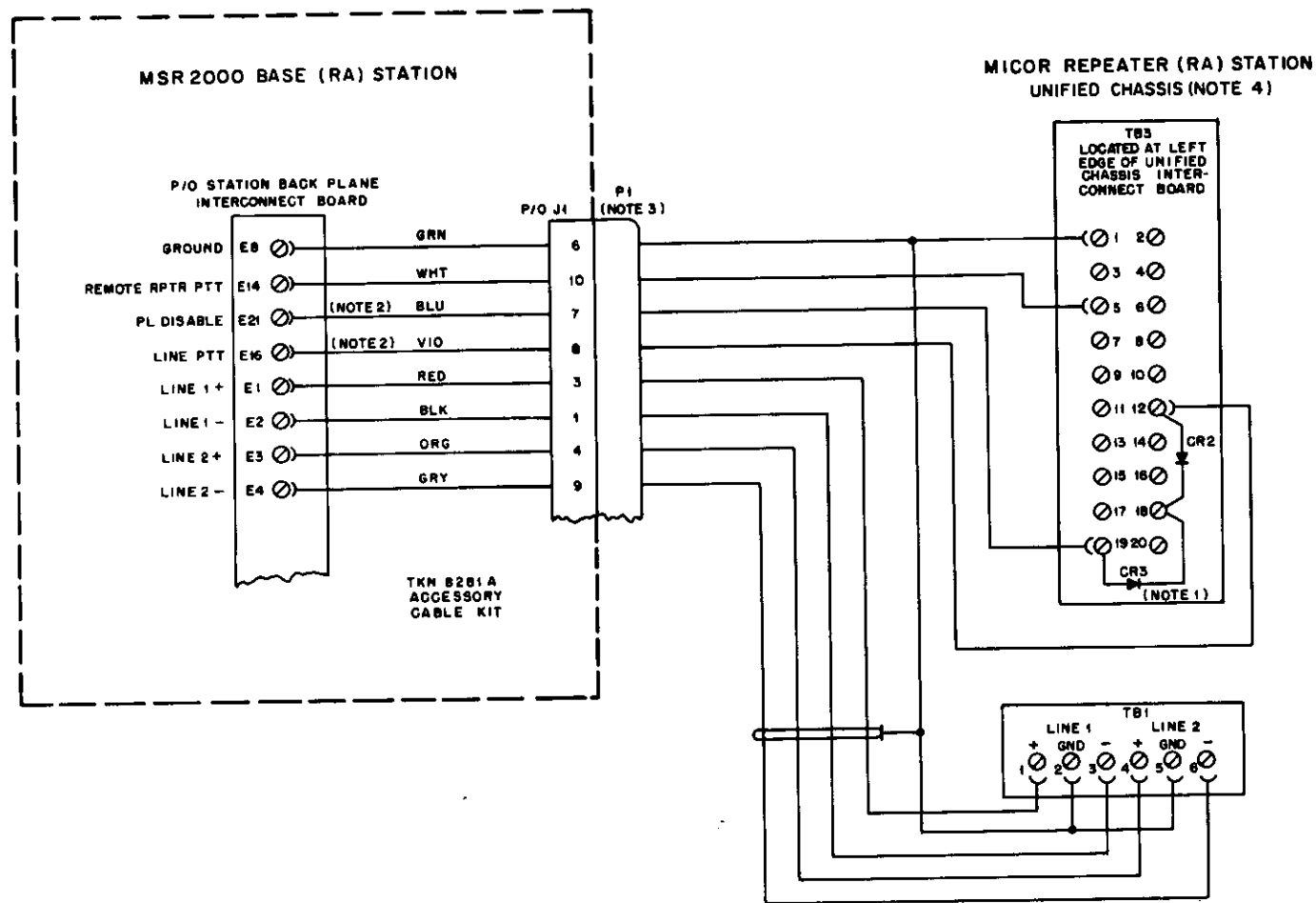

CAUTION
REMOVE DIODE CR15 AND RESISTOR R59 IN SQUELCH GATE MODULES OF BOTH STATIONS WHEN RELAY K1 IS NOT USED.

- NOTES:**
- IF PL/DPL DISABLE IS REQUIRED, CR2 AND CR3 (MOTOROLA PART NO. 48-82392 803) SHOULD BE INSTALLED ON THE REPEATER (RA) STATION. THE 5-SECOND JUMPER (JU1) IN THE SINGLE TONE DECODER MODULE MUST BE REMOVED.
 - "LINE PTT" AND "PL DISABLE" LINES ARE NOT CONNECTED IN GUARD TONE RELAY APPLICATIONS.
 - CONNECTOR P1 IS SUPPLIED WITH MSR 2000 BASE (RA) STATION, AS PART OF TKN 8281A KIT. INTERSTATION CABLING IS NOT SUPPLIED.
 - FOR REPEATER (RA) STATIONS OTHER THAN SHOWN REFER TO APPROPRIATE REPEATER (RA) STATION MANUAL. INTERCONNECT MATCHING FUNCTIONS.

CEPS-34869-0

parts list

TKN8281A Auxiliary Interconnect Cable PL-8087-0

REFERENCE SYMBOL	MOTOROLA PART NO.	DESCRIPTION
J1	9-84538E03	connector, receptacle: female; 25-contact
mechanical parts		
	2-84586C01	NUT, machine; 4-40; square; 2 used
	3-129874	SCREW, machine; 4-40 x 3/16"; 2 used
	29-812979	LUG, crimp terminal; 10 used
	42-10217A02	STRAP, tie; 12 used
	30-86970A02	CABLE; 10 conductor; 48" used
	43-10646A09	SPACER; 2 used
	28-84506E08	CONNECTOR, male; 25-contact
	15-82488M01	HOOD

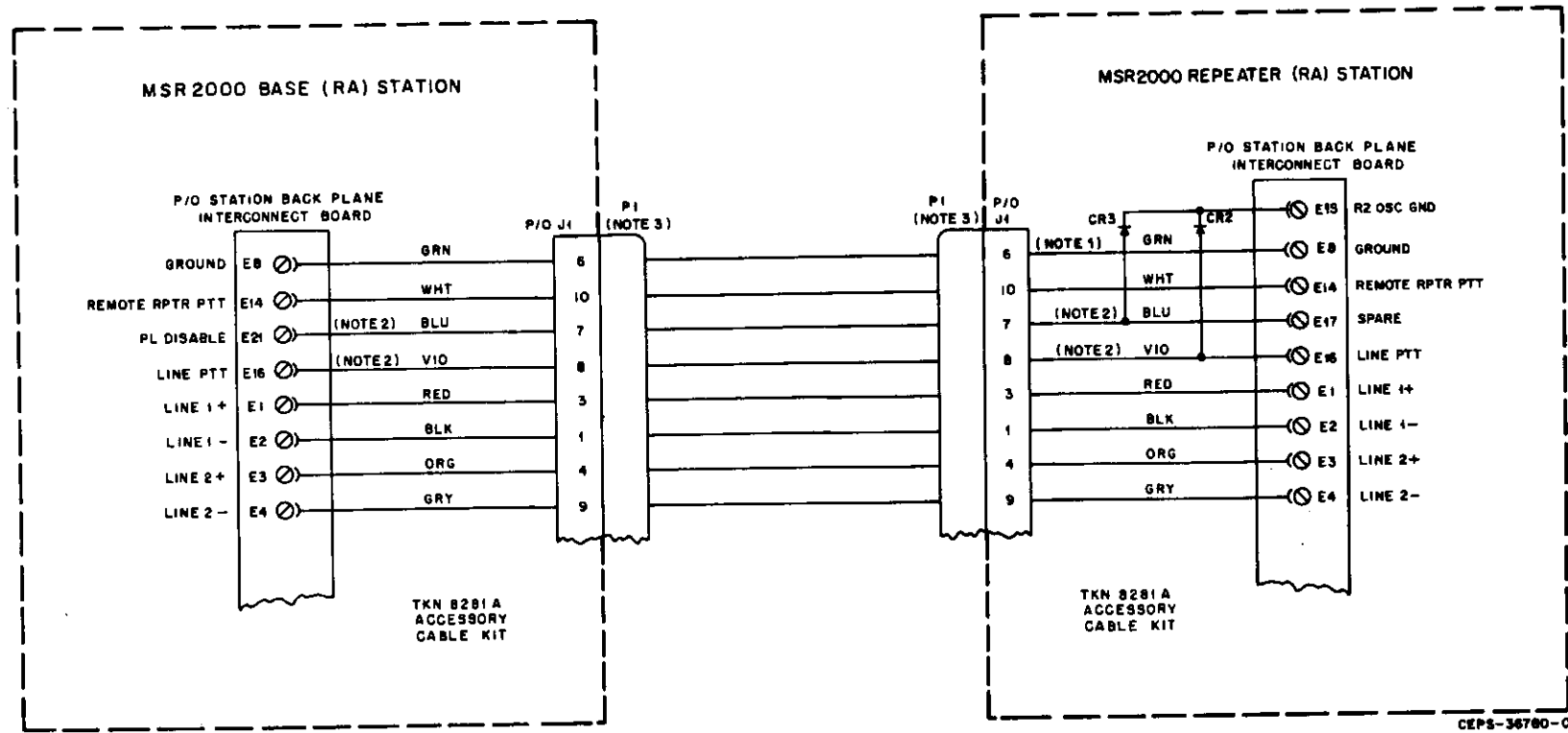

CAUTION
REMOVE DIODE CR15 AND RESISTOR R59 IN SQUELCH GATE MODULES OF BOTH STATIONS WHEN RELAY K1 IS NOT USED.

- NOTES:**
- IF PL/DPL DISABLE IS REQUIRED, CR2 AND CR3 (MOTOROLA PART NO. 48-82392 803) SHOULD BE INSTALLED ON THE REPEATER (RA) STATION. THE 5-SECOND JUMPER (JU1) IN THE SINGLE TONE DECODER MODULE MUST BE REMOVED.
 - "LINE PTT" AND "PL DISABLE" LINES ARE NOT CONNECTED IN GUARD TONE RELAY APPLICATIONS.
 - CONNECTOR P1 IS SUPPLIED WITH EACH MSR 2000 RA STATION, AS PART OF TKN 8281A KIT. INTERSTATION CABLING IS NOT SUPPLIED.

CEPS-36780-0

*Base (RA) To Repeater (RA)
Station Interconnect Diagrams and Parts List
Motorola No. PEPS-37325-0
8/19/83- V & G*

DYNAMIC MICROPHONE

MODEL TMN6054A

electrical parts list

important
Use *only* the following Motorola part numbers when ordering replacement parts.

TMN6054A Microphone PL-8092-O

REFERENCE SYMBOL	MOTOROLA PART NO.	DESCRIPTION
DP1	59-83272G01 or 59-84013A01 or 59-82933C02	cartridge, microphone: dynamic; includes transistor preamplifier
P1103	—	connector, plug: part of W1
W1	30-83731M01	cord, microphone, coiled: 4-conductor; includes ref. part P1, CLAMP, cable "S" hook (ref. part 13), SPRING, strain relief (ref. part 12), and non-ref. LUG (4 req'd.) 29-83277G02
S1	40-82263G02	switch, push: dpst
non-referenced items		
	29-83277G02	LUG, insulation piercing: 4 req'd. (p/o W1)
	33-82599D01	NAMEPLATE
	13-84599B01	EMBLEM

mechanical parts list

TMN6054A Microphone PL-8093-O

CODE	MOTOROLA PART NO.	DESCRIPTION
1	38-84559B01	PUSHBUTTON
2	3-140000	SCREW, tapping: no. 6-19 x 3/8"; 3 req'd.
5	3-122830	SCREW, tapping: no. 8 x 1/2"; 2 req'd.
6	1-80707T05	BRACKET & SPRING ASSY. (eyeletted)
7	1-80709B93	HOUSING, microphone (front and rear)
8	3-129498	SCREW, lock: no. 6-32 x 5/16"; "Phillips" round head
9	4-7666	LOCKWASHER: no. 6 external
10	42-852710	STRAP, strain relief
11	3-139999	SCREW, tapping: no. 6-19 x 3/4"; "Phillips" round head; 2 req'd.
12	41-852707	SPRING, strain relief (p/o W1)
13	42-893647	CLAMP, cable "S" hook (p/o W1)
15	42-82702B02	RETAINER, cartridge
16	32-82703B01	GASKET, neoprene
17	11-2506	TUBING, no. 9 black; 5" length req'd.

