



**MSR 2000™**

**VHF Base and Repeater Stations**  
132-174 MHz



**MUST BE USED WITH**  
**Associated Control and Audio Instruction Manual**  
**68P81061E40**

THIS MANUAL HAS BEEN  
**DISCONTINUED**

68P81061E50-C



## CONTENTS

| <i>SECTION</i>  | <i>NUMBER</i>           |
|---|-------------------------|
| Commercial Warranty and Computer Software Copyrights .....        | inside cover            |
| Foreword .....  | Pages vii, viii         |
| Performance Specifications — Intermittent Duty .....              | Page ix                 |
| Model Chart — Intermittent Duty (Earlier Version) .....           | Page x                  |
| Model Breakdown Chart — Intermittent Duty (Earlier Version) ..... | Page xi                 |
| Model Chart — Intermittent Duty (Later Version) .....             | Page xii                |
| Model Breakdown Chart — Intermittent Duty (Later Version) .....   | Page xiii               |
| Model Chart — Continuous Duty (Earlier Version) .....             | Page xiv                |
| Model Breakdown Chart — Continuous Duty (Earlier Version) .....   | Page xv                 |
| Model Chart — Continuous Duty (Later Version) .....               | Page xvi                |
| Model Breakdown Chart — Continuous Duty (Later Version) .....     | Page xvii               |
| Option Chart — Intermittent Duty .....                            | Pages xviii, xix, xx    |
| Performance Specifications — Continuous Duty .....                | Page xxi                |
| Option Chart — Continuous Duty .....                              | Pages xxii, xxiii, xxiv |
| General Safety Information .....                                  | EPS-28750               |

## DESCRIPTION

|  |                    |
|--|--------------------|
| <b>DESCRIPTION .....</b>               | <b>68P81062E49</b> |
| 1. Manual Usage .....                  | Page 1             |
| 2. Introduction .....                  | Page 1             |
| 3. Station Component Description ..... | Page 2             |
| 3.1 Transmitter .....                  | Page 2             |
| 3.2 Receiver .....                     | Page 2             |
| 3.3 Power Supply .....                 | Page 3             |
| 4. Unique Features .....               | Page 3             |
| 5. Options .....                       | Page 4             |

## INSTALLATION

|   |                    |
|---|--------------------|
| <b>LIGHTNING PROTECTION RECOMMENDATIONS .....</b>                                   | <b>68P81111E17</b> |
| <b>INSTALLATION .....</b>   | <b>68P81062E54</b> |
| 1. FCC Requirements .....   | Page 1             |
| 2. Inspection .....   | Page 1             |
| 3. Planning the Installation .....  | Page 1             |
| 4. Ventilation .....  | Page 1             |
| 5. Installation of 24-, 29-, 32-, and 37-inch Indoor <i>MSR 2000</i> Cabinets ..... | Page 1             |
| 6. Antenna Connections .....  | Page 3             |

SECTION

NUMBER

- 7. AC Input Power and Ground Connections ..... Page 3
  - 7.1 Introduction ..... Page 3
  - 7.2 Station Installation Using Power Line Cord Supplied with the Station ..... Page 4
  - 7.3 Station Installation Using Conduit For Primary Power Connection ..... Page 4
- 8. Optional DC Input Power Connections ..... Page 4
- 9. Optional Mode Jumpering ..... Page 5
  - 9.1 General ..... Page 5
  - 9.2 Time-Out Timer Module ..... Page 5
  - 9.3 Squelch Gate ..... Page 5
  - 9.4 Two-Receiver Stations ..... Page 5
- 10. Control Line Connections ..... Page 5
  - 10.1 Introduction ..... Page 5
  - 10.2 Line Specifications ..... Page 5
  - 10.3 Installation ..... Page 6
- 11. Control Line Level Adjustment ..... Page 6
  - 11.1 General Information ..... Page 6
  - 11.2 Adjustments ..... Page 7

**MAINTENANCE**

**STATION MAINTENANCE.....68P81062E53**

- 1. Introduction ..... Page 1
- 2. Local Operation ..... Page 1
  - 2.1 General ..... Page 1
  - 2.2 Transmitter Control ..... Page 2
  - 2.3 Local Microphone ..... Page 2
  - 2.4 Local Speaker ..... Page 2
  - 2.5 Handset ..... Page 2
  - 2.6 Portable Test Set (For Stations Without Built-In Metering) ..... Page 2
  - 2.7 Frequency Selection ..... Page 2
  - 2.8 Selection of Other Modes ..... Page 2
  - 2.9 Received Audio ..... Page 2
  - 2.10 Transmitting ..... Page 2
  - 2.11 Concluding Local Operation ..... Page 2
- 3. Maintenance Techniques ..... Page 3
  - 3.1 General ..... Page 3
  - 3.2 Transmitter and Receiver ..... Page 3
  - 3.3 Power Supply ..... Page 3
  - 3.4 Remote Control Unit ..... Page 3
- 4. Recommended Test Equipment ..... Page 4
- 5. Disassembly and Service Access ..... Page 4
  - 5.1 Front Cover and Line Fuse ..... Page 4
  - 5.2 Power Amplifier Access and Removal ..... Page 5
  - 5.3 RF Control Chassis Access and Removal ..... Page 6
  - 5.4 Exciter and Receiver Access and Removal ..... Page 6
  - 5.5 Speaker Intercom With Speaker and DC Metering Chassis Access ..... Page 7
  - 5.6 Duplexer Removal ..... Page 7
  - 5.7 Power Supply Access ..... Page 7
  - 5.8 Two-Receiver Coupler Removal ..... Page 9
  - 5.9 Junction Box Access ..... Page 9
  - 5.10 Wraparound Cover Removal ..... Page 9
- 6. Mechanical Parts Identification ..... Page 9
  - MSR 2000* Basic Model Station Mechanical Parts Identification ..... Page 11
  - MSR 2000* Fully Optionable Model Station Mechanical Parts Identification ..... Page 15
  - MSR 2000* Base Station Service Intercom With Speaker and DC Metering Chassis  
 Mechanical Parts Identification ..... Page 19
  - MSR 2000* Base Station Power Amplifier Mechanical Parts Identification ..... Page 20
  - MSR 2000* Base Station Miscellaneous Parts Lists ..... Page 21

|  |                |
|--|----------------|
| MSR 2000 Intermittent Duty Base Station RF Intercabling Diagram and Parts List .....   | Page 23        |
| MSR 2000 Intermittent Duty Base Station TKN8234A Main Wiring Harness<br>Schematic Diagram and Parts List .....   | Page 24        |
| MSR 2000 Continuous Duty Base Station RF Intercabling Diagram and Parts Lists .....  | Page 25        |
| MSR 2000 Continuous Duty Base Station TKN8319A Main Wiring Harness<br>Schematic Diagram and Parts Lists .....  | Page 26        |
| TKN8320A and TKN8321A Two-Wire and Four-Wire EIA Cable Kit;<br>and TKN8286A and TKN8287A Two-Wire and Four-Wire Line Cable Kit<br>Schematic Diagram and Parts List ..... | Page 27        |
| Junction Box .....   | PEPS-38058     |
| Models TRN9113A/14A .....  | (Sheet 1 of 2) |
| Models TRN5350A/51A .....  | (Sheet 2 of 2) |

## RECEIVER

|  |                     |
|--|---------------------|
| <b>RECEIVER (Model Series TRD6290A, TRD6300A &amp; TRD6310A) .....</b> | <b>.68P81070E54</b> |
| 1. Description .....   | Page 1              |
| 2. Theory of Operation .....   | Page 2              |
| 2.1 PI Filter, RF Preselector, Optional Preamplifier .....             | Page 2              |
| 2.2 Local Oscillator Injection Circuitry .....                         | Page 2              |
| 2.3 Mixer .....  | Page 2              |
| 2.4 I-F Circuitry .....  | Page 2              |
| 2.5 Limiter/Detector .....   | Page 2              |
| 2.6 9.5 Volt Regulator .....   | Page 2              |
| 2.7 Delayed Keyed A + .....  | Page 2              |
| 3. Maintenance .....   | Page 2              |
| 4. Receiver Functional Tests .....                                     | Page 3              |
| 4.1 Audio and Squelch Test .....                                       | Page 3              |
| 4.2 20 dB Quieting Test .....  | Page 4              |
| 4.3 Receiver Gain Measurements .....                                   | Page 4              |
| 5. Troubleshooting Techniques .....                                    | Page 4              |
| 5.1 Visual Inspection .....  | Page 4              |
| 5.2 Alignment as a Troubleshooting Technique .....                     | Page 4              |
| 5.3 Troubleshooting Integrated Circuits .....                          | Page 4              |
| 5.4 Troubleshooting Crystals .....                                     | Page 4              |
| VHF Troubleshooting Chart & Functional Block Diagram .....             | PEPS-41771          |
| VHF Receiver Alignment Procedure .....                                 | PEPS-41722          |
| Schematic Diagram, Circuit Board Detail & Parts Lists .....            | PEPS-41724          |

|  |                     |
|--|---------------------|
| <b>RECEIVER (Model Series TRD6170A, TRD6180A &amp; TRD6190A) .....</b> | <b>.68P81061E99</b> |
| 1. Description .....   | Page 1              |
| 2. Theory of Operation .....   | Page 2              |
| 2.1 PI Filter, RF Preselector, Optional Preamplifier .....             | Page 2              |
| 2.2 Local Oscillator Injection Circuitry .....                         | Page 2              |
| 2.3 Mixer .....  | Page 2              |
| 2.4 I-F Circuitry .....  | Page 2              |
| 2.5 Limiter/Detector .....   | Page 2              |
| 2.6 9.5 Volt Regulator .....   | Page 2              |
| 2.7 Delayed Keyed A + .....  | Page 2              |
| 3. Maintenance .....   | Page 2              |
| 4. Receiver Functional Tests .....                                     | Page 3              |
| 4.1 Audio and Squelch Test .....                                       | Page 3              |
| 4.2 20 dB Quieting Test .....  | Page 4              |
| 4.3 Receiver Gain Measurements .....                                   | Page 4              |
| 5. Troubleshooting Techniques .....                                    | Page 4              |
| 5.1 Visual Inspection .....  | Page 4              |
| 5.2 Alignment as a Troubleshooting Technique .....                     | Page 4              |
| 5.3 Troubleshooting Integrated Circuits .....                          | Page 4              |
| 5.4 Troubleshooting Crystals .....                                     | Page 4              |
| Receiver Troubleshooting Chart .....                                   | Page 5              |

## SECTION

## NUMBER

|  |            |
|--|------------|
| Receiver Alignment .....   | PEPS-34505 |
| Receiver Maintenance Schematic Diagram, Circuit Board Detail & Parts Lists ..... | PEPS-34544 |

**TRANSMITTER**

|   |                     |
|---|---------------------|
| <b>TRANSMITTER .....</b>  | <b>.68P81062E36</b> |
| 1. General .....  | Page 2              |
| 2. Exciter .....  | Page 2              |
| 3. Power Amplifier .....  | Page 2              |
| 4. Alignment .....  | Page 2              |
| Intermittent Duty Transmitter Functional Interconnect Diagram ..... | Page 3              |
| Continuous Duty Transmitter Functional Interconnect Diagram .....   | Page 4              |
| Intermittent Duty Transmitter Alignment .....                       | PEPS-34373          |
| Continuous Duty Transmitter Alignment .....                         | PEPS-35367          |

|   |                     |
|---|---------------------|
| <b>EXCITER .....</b>                                  | <b>.68P81062E37</b> |
| 1. Description .....                                  | Page 1              |
| 2. Theory of Operation .....                          | Page 1              |
| 2.1 Transmit Audio Circuit .....                      | Page 1              |
| 2.2 Channel Elements .....                            | Page 1              |
| 2.3 Multipliers and Amplifiers .....                  | Page 1              |
| 3. Exciter Functional Tests .....                     | Page 2              |
| 3.1 Exciter Power Output Test .....                   | Page 2              |
| 3.2 Frequency Test .....                              | Page 2              |
| 3.3 Deviation Test .....                              | Page 2              |
| 4. Troubleshooting .....                              | Page 2              |
| Earlier Version Circuit Board Detail .....            | Page 5              |
| Later Version Circuit Board Detail & Parts List ..... | Page 6              |
| Schematic Diagram .....                               | Page 7              |

|  |                     |
|--|---------------------|
| <b>POWER AMPLIFIER — INTERMITTENT DUTY .....</b>                   | <b>.68P81062E38</b> |
| 1. General .....   | Page 1              |
| 2. Theory of Operation .....                                       | Page 1              |
| 2.1 Power Amplifier Board .....                                    | Page 1              |
| 2.2 Power Control Circuitry .....                                  | Page 1              |
| 3. Power Amplifier Servicing .....                                 | Page 2              |
| 3.1 General .....  | Page 2              |
| 3.2 Power Amplifier Board Troubleshooting Procedure .....          | Page 2              |
| 3.3 Power Amplifier Transistor Replacement .....                   | Page 3              |
| 3.4 Power Amplifier Board Removal .....                            | Page 4              |
| 3.5 Power Amplifier Functional Tests .....                         | Page 4              |
| Power Control Board Schematic Diagram & Circuit Board Detail ..... | Page 7              |
| Power Amplifier Board Circuit Board Detail & Parts Lists .....     | Page 8              |
| Power Amplifier Board Schematic Diagram .....                      | Page 9              |

|  |                     |
|--|---------------------|
| <b>POWER AMPLIFIER — CONTINUOUS DUTY .....</b>               | <b>.68P81063E01</b> |
| 1. General .....   | Page 1              |
| 2. Theory of Operation .....                                 | Page 1              |
| 2.1 Power Amplifier Board .....                              | Page 1              |
| 2.2 Power Control Board Functional Theory of Operation ..... | Page 1              |
| 2.3 Power Control Board Detailed Theory of Operation .....   | Page 3              |
| 3. Maintenance .....   | Page 5              |
| 3.1 Power Amplifier Board .....                              | Page 5              |
| 3.2 Power Control Board .....                                | Page 7              |
| 4. Troubleshooting Procedures .....                          | Page 9              |
| 4.1 General .....  | Page 9              |
| 4.2 Visual .....   | Page 9              |
| 4.3 Voltage Checks .....                                     | Page 9              |
| 4.4 Troubleshooting .....                                    | Page 9              |

**SECTION**

**NUMBER**

5. Repair Procedures .....Page 10

5.1 Resistance Measurements of Transistors in Push-Pull Pairs .....Page 10

5.2 Transistor Removal Procedure .....Page 10

5.3 Transistor Installation Procedure .....Page 10

5.4 Procedures for Resistance Measurements of Transistors .....Page 10

Power Control Board Troubleshooting Chart .....Page 11

Power Amplifier Troubleshooting Chart .....Page 12

TRN5585A Exciter Control Voltage Regulator Schematic Diagram,  
Circuit Board Detail, and Parts Lists .....Page 13

TLD5960A Power Control Board Schematic Diagram, Circuit Board Detail and Parts Lists .....Page 14

TLD5950A Series Power Amplifier Board Schematic Diagram,  
Circuit Board Detail and Parts Lists .....Page 15

**ANTENNA SWITCH** .....68P81062E33

**POWER SUPPLY**

**STANDARD POWER SUPPLY** .....68P81062E46

1. Description .....Page 1

2. Theory of Operation .....Page 2

2.1 TRN5336A Standard Power Supply .....Page 2

2.2 TPN6138B Distribution Board .....Page 2

2.3 TRN5119A Auxiliary Regulator Board .....Page 2

3. Regulated Output Voltage Adjustment Procedure .....Page 4

4. Maintenance .....Page 4

4.1 Introduction .....Page 4

4.2 Test Equipment Required .....Page 4

4.3 Auxiliary Regulator Chassis Removal .....Page 4

4.4 Power Supply Removal .....Page 5

Troubleshooting Chart .....Page 7

Cable Interconnect Wiring Diagram .....Page 10

Functional Block Diagram .....Page 11

TRN5336A Standard Power Supply Hardware Kit and TPN6138A Distribution Board  
Schematic Diagram, Circuit Board Details, and Parts Lists .....PEPS-34737

TRN5119A Auxiliary Regulator Board Schematic Diagram, Circuit Board Detail, and Parts List .....PEPS-38130

**OPTION C28AN BATTERY CHARGER POWER SUPPLY** .....68P81062E47

1. Description .....Page 1

2. Theory of Operation .....Page 2

2.1 TRN5336A Standard Power Supply .....Page 2

2.2 TRN6137A Battery Charger Board .....Page 3

2.3 TRN5119A Auxiliary Regulator Board .....Page 3

2.4 TRN5120A Battery Revert Control Board .....Page 5

3. Battery Connection and Installation .....Page 6

3.1 Power Supply .....Page 6

3.2 Battery Protection and Alarm .....Page 7

4. Level Adjustments .....Page 7

4.1 A + Voltage Adjustment .....Page 7

4.2 Regulated Output Voltage Adjustment .....Page 7

4.3 Alarm Tone Level Adjustment .....Page 7

4.4 Low-Voltage Detector Adjustment .....Page 8

5. Maintenance .....Page 8

5.1 Introduction .....Page 8

5.2 Test Equipment Required .....Page 8

5.3 Auxiliary Regulator Chassis Removal .....Page 8

5.4 Power Supply Removal .....Page 8

5.5 Battery Maintenance .....Page 9

Troubleshooting Chart .....Page 13

## SECTION

## NUMBER

|  |            |
|--|------------|
| Parts Lists and Location .....   | Page 15    |
| Functional Block Diagram .....   | Page 17    |
| TRN5336A Power Supply and TRN6137A Battery Charger Board Schematic Diagram,<br>Circuit Board Detail, and Parts Lists ..... | PEPS-34740 |
| TRN5119A Auxiliary Regulator Board Schematic Diagram, Circuit Board Detail, and Parts List ..                              | PEPS-34738 |
| TRN5120A Battery Revert Control Board Schematic Diagram, Circuit Board Detail,<br>and Parts List .....                     | PEPS-34742 |
| TPN1192A Battery Charger Power Supply Cable Interconnect Wiring Diagram .....  | DEPS-34366 |

## ACCESSORIES

|   |                    |
|---|--------------------|
| <b>DUPLEXER</b> .....   | <b>68P81062E34</b> |
| 1. Introduction .....   | Page 1             |
| 2. Field Installation .....   | Page 1             |
| 3. Theory of Operation .....  | Page 2             |
| 4. Removal/Replacement of Coupling Loops .....                                | Page 3             |
| 4.1 Removal Procedure .....   | Page 3             |
| 4.2 Replacement Procedure .....   | Page 3             |
| 5. Recommended Tuning Procedure .....   | Page 4             |
| 5.1 Method 1 .....  | Page 4             |
| 5.2 Method 2 .....  | Page 4             |
| 5.3 Minor "Touch-Up" Procedures .....   | Page 5             |
| 5.4 Tuning the Notch .....  | Page 6             |
| <b>2-RECEIVER COUPLER (TRD6270A)</b> .....                                    | <b>68P81063E03</b> |
| 1. Electrical Description .....   | Page 1             |
| 2. Physical Description .....   | Page 1             |
| 3. Installation .....   | Page 1             |
| Schematic Diagram & Parts Lists .....   | Page 3             |
| <b>2-RECEIVER COUPLER</b> .....   | <b>68P81062E32</b> |
| 1. Electrical Description .....   | Page 1             |
| 2. Physical Description .....   | Page 1             |
| Schematic Diagram & Parts Lists .....   | Page 2             |
| <b>MSR 2000 BASE STATION SERVICE ACCESSORIES</b> .....                        | <b>68P81062E44</b> |
| 1. Description .....  | Page 2             |
| 2. Operating Instructions .....   | Page 2             |
| 2.1 Local Speaker .....   | Page 2             |
| 2.2 Metering .....  | Page 2             |
| Schematic Diagram & Parts Lists .....   | Page 3             |
| <b>MSR 2000 BASE (RA), REPEATER (RA) CONFIGURATION</b> .....                  | <b>68P81112E71</b> |
| 1. Description and Application .....  | Page 1             |
| 2. Connections Between Base (RA) and Repeater (RA) Stations .....             | Page 3             |
| Base (RA) To Repeater (RA) Station Interconnect Diagrams and Parts List ..... | PEPS-37325         |
| <b>DYNAMIC MICROPHONE</b> .....   | <b>68P81062E39</b> |

# INTERMITTENT DUTY STATION PERFORMANCE SPECIFICATIONS

## GENERAL

| Model              | Frequency (MHz) | Minimum RF Output Power | Maximum PA Final Input Power  | Input Voltage                         | A.C. Input Current |      |                            |      |
|--------------------|-----------------|-------------------------|---|---------------------------------------|--------------------|------|----------------------------|------|
|                    |                 |                         |   |                                       | Standard Supply    |      | Battery Charging*** Supply |      |
|                    |                 |                         |   |                                       | Stby               | Xmit | Stby                       | Xmit |
| C73GRB<br>C73GSB*  | 146-174         | 110 W**                 | 290 W   | 120 V ac +10%<br>-20%; 60 Hz Standard | 1A                 | 5.5A | 1.5-2A                     | 5.5A |
| No. of Frequencies |                 |                         | Single and two-frequency stations (dc and tone remote)<br>Four-frequency stations (tone remote)   |                                       |                    |      |                            |      |
| Squelch Options    |                 |                         | Carrier squelch, <i>Private-Line</i> coded squelch, and <i>Digital Private-Line</i> coded squelch |                                       |                    |      |                            |      |
| Metering           |                 |                         | Optional internal-mounted meter used to measure all essential circuits for tuning and checking.   |                                       |                    |      |                            |      |

\*Fully Optionable Models

\*\*Variable Down to 60 W

\*\*\*Does Not Include Battery Charging Current

## TRANSMITTER 146-174 MHz

|                                |  |
|--------------------------------|--|
| RF Output Power                | 110/60 watts intermittent duty (cont. variable)  |
| Output Impedance               | 50 ohms  |
| Oscillator Frequency Stability | Channel element maintains oscillator frequency within $\pm .0005\%$ ( $\pm .0002\%$ optional) from $-30^{\circ}\text{C}$ to $+60^{\circ}\text{C}$ ambient ( $+25^{\circ}\text{C}$ reference) |
| Transmitter Sideband Noise     | -90 dB @30 kHz<br>-105 dB @1 MHz   |
| Spurious & Harmonics           | More than 85 dB below carrier  |
| Modulation                     | 15F2 and 16F3: $\pm 5$ kHz for 100% at 1000 Hz.  |
| Audio Sensitivity              | Remote telephone line: -20 dBm max. for 60% max. dev. at 1000 Hz.  |
| FM Noise                       | 55 dB below 60% system dev. at 1000 Hz   |
| Audio Response                 | +1, -3 dB from 6 dB/octave pre-emphasis, 300-3000 Hz, referenced to 1000 Hz  |
| Audio Distortion               | Less than 2% at 1000 Hz; 60% system dev.   |
| FCC Designation                | ABZ89FC3632 ( $\pm .0005\%$ stability)<br>ABZ89FC3132C ( $\pm .0002\%$ stability)<br>Licensable under parts 22, 74, 81, and 90 of FCC Rules.   |

## RECEIVER 146-174 MHz

|  |   |  |
|--|---|--|
| Channel Spacing  | 30 kHz/25 kHz   |  |
| EIA Modulation Acceptance                                    | $\pm 7$ kHz minimum   |  |
| Oscillator Frequency Stability                               | Channel element maintains oscillator frequency within $\pm .0005\%$ ( $\pm .0002\%$ optional) from $-30^{\circ}\text{C}$ to $+60^{\circ}\text{C}$ ambient ( $+25^{\circ}\text{C}$ reference)  |  |
| Sensitivity<br>20 dB Quieting<br>EIA SINAD                   | <b>Without Preamp</b><br>Less than 0.5 uV<br>Less than 0.35 uV  | <b>With Preamp</b><br>Less than 0.25 uV<br>Less than 0.20 uV |
| Intermodulation — EIA SINAD                                  | -85 dB  | -80 dB   |
| Selectivity — EIA SINAD                                      | -100 dB (-95 dB with preamp)  |  |
| Spurious & Image Rejection                                   | 100 dB minimum  | 100 dB minimum   |
| Squelch Sensitivity<br>Carrier Squelch<br>Tone-Coded Squelch | 0.2 uV or less at threshold<br>0.2 uV or less   | 0.10 uV or less at threshold<br>0.10 uV or less              |
| Audio Characteristics<br>Remote Control Models               | <b>Telephone Line:</b><br>Output: +11 dBm @600 ohms<br>Response: +1, -3 dB<br>Distortion: 3% @1000 Hz<br>Hum & Noise: -55 dB<br><b>For local service audio:</b><br>Output Available: 1 W @8 ohms<br>Response: +2, -8 dB<br>Distortion: 5% @1000 Hz<br>Hum & Noise: -55 dB |  |
| FCC Receiver Certification Number                            | ABZ89FR3633   |  |

Meets EIA Specifications per RS152B, RS204B, and RS220A.

SPECIFICATIONS SUBJECT TO CHANGE WITHOUT NOTICE



**GRB "A" SUFFIX MODELS [BASIC]  
GSB "A" SUFFIX MODELS [FULLY OPTIONABLE]  
MODEL CHART  
FOR  
MSR 2000  
INTERMITTENT DUTY  
BASE/REPEATER (RT) STATIONS  
146-174 MHz 110 W RF POWER OUTPUT  
EARLIER VERSION**

| MODEL     | DESCRIPTION                                  |
|-----------|--|
| KLN6209A  | VIBRATOR RESONANT REED                       |
| KXN1068B  | RECEIVE ELEMENT (10.7 MHz IF) 5 PPM          |
| KXN1068BA | RECEIVE ELEMENT (10.8 MHz IF) 5 PPM          |
| KXN1068A  | TRANSMIT ELEMENT 5 PPM                       |
| TKN8234B  | STATION INTERCONNECT CABLE                   |
| TKN8286A  | TWO-WIRE LINE CABLE                          |
| TKN8288A  | PA POWER/EXCITER CABLE                       |
| TKN8289A  | NON-DUPLEXER CABLES                          |
| TLD2532A  | 110 W PA                                     |
| TLD9232A  | SIMPLEX EXCITER                              |
| TLD9242A  | DUPLEX EXCITER                               |
| TLN2443A  | GUARD TONE DECODER MODULE                    |
| TLN2444A  | C2-R2 F2 TONE DECODER MODULE                 |
| TLN2472A  | BASIC CHASSIS                                |
| TLN2473A  | FULLY OPTIONAL CHASSIS (1 REC)               |
| TLN2474A  | FULLY OPTIONAL CHASSIS (2 REC)               |
| TLN2475A  | FULLY OPTIONAL CHASSIS (REPEATER RT)         |
| TPN1191A  | STANDARD POWER SUPPLY                        |
| TRD6172A  | RECEIVER 10.7 MHz NON-FILTERED               |
| TRD6182A  | RECEIVER 10.7 MHz FILTERED                   |
| TRD6192A  | RECEIVER 10.8 MHz FILTERED                   |
| TRD6210A  | 2 RECEIVER COUPLER                           |
| TRN5068A  | R1 AUDIO BOARD                               |
| TRN5070A  | R2 AUDIO BOARD                               |
| TRN5071A  | R2 AUDIO PL BOARD                            |
| TRN5072A  | R2 AUDIO DPL BOARD                           |
| TRN5073A  | DUPLEX PL BOARD                              |
| TRN5074A  | SIMPLEX PL TA-RA BOARD                       |
| TRN5076A  | DUPLEX DPL BOARD                             |
| TRN5077A  | SIMPLEX DPL TA-RA BOARD                      |
| TRN5122A  | ANTENNA RELAY                                |
| TRN5236A  | 1 RECEIVER, 2 WIRE AUDIO; LINE DRIVER MODULE |
| TRN5237A  | 2 RECEIVER, 2 WIRE AUDIO; LINE DRIVER MODULE |
| TRN5240A  | F1 PL CONTROL MODULE                         |
| TRN5254A  | F1 CARRIER SQUELCH CONTROL MODULE            |
| TRN5255A  | C2-R2 CONTROL MODULE                         |
| TRN5256A  | F2-R2 MUTE CONTROL MODULE                    |
| TRN5295A  | CMOS TIME-OUT TIMER                          |
| TRN5296A  | 4-FREQUENCY CONTROL MODULE                   |
| TRN5320A  | F1 PL TONE DECODER MODULE                    |
| TRN5321A  | STATION CONTROL MODULE                       |
| TRN5322A  | F1 TONE DECODER MODULE                       |
| TRN5324A  | SQUELCH GATE MODULE                          |
| TRN5325A  | F2 TONE DECODER MODULE                       |
| TRN5327A  | 4F F1 TONE DECODER MODULE                    |
| TRN5328A  | 4F F1-PL TONE DECODER MODULE                 |
| TRN5350A  | SIMPLEX JUNCTION BOX                         |
| TRN5351A  | DUPLEX JUNCTION BOX                          |
| TRN5352A  | RF PLASTIC PLUG                              |
| TRN5353A  | D-TYPE CONNECTOR PLASTIC PLUG                |
| TRN5355A  | BATTERY PLASTIC PLUG                         |
| TLN2515A  | FULLY OPTIONAL CHASSIS (4-FREQ.)             |
| TRN5423A  | 24" CABINET HARDWARE                         |
| TRN5425A  | 24" CABINET SHELL                            |
| TRN5427A  | 110V POWER CORD                              |
| TRN5428A  | INTERMITTENT PA HARDWARE                     |
| TRN5429A  | BASIC COVERS                                 |
| TRN5430A  | OPTIONAL COVERS                              |
| TRN5431A  | REPEATER COVERS                              |
| TRN5443A  | DUPLEX RF COVER                              |
| TRN6005A  | DPL CODE PLUG                                |

| STATION MODEL                 | TYPE OF SQUELCH | T1 = ONE XMIT FREQ.<br>T2 = TWO XMIT FREQS.<br>R1 = ONE RCVR. FREQ.<br>R2 = TWO RCVR. FREQS.<br>2R = TWO RCVRS. — ONE FREQ. EACH | CONTROL TYPE |
|-------------------------------|-----------------|--|--------------|
| <b>BASE STATIONS</b>          |                 |  |              |
| C73GRB-1105A                  | CARRIER         | T1-R1  | DC           |
| C73GRB-1106A                  | CARRIER         | T1-R1  | TONE         |
| C73GRB-1115A                  | CARRIER         | T2-R1  | DC           |
| C73GRB-1116A                  | CARRIER         | T2-R1  | TONE         |
| C73GRB-1125A                  | CARRIER         | T2-R2  | DC           |
| C73GRB-1126A                  | CARRIER         | T2-R2  | TONE         |
| C73GRB-3105A                  | PL              | T1-R1  | DC           |
| C73GRB-3106A                  | PL              | T1-R1  | TONE         |
| C73GRB-3115A                  | PL              | T2-R1  | DC           |
| C73GRB-3116A                  | PL              | T2-R1  | TONE         |
| C73GRB-3125A                  | PL              | T2-R2  | DC           |
| C73GRB-3126A                  | PL              | T2-R2  | TONE         |
| C73GRB-6105A                  | DPL             | T1-R1  | DC           |
| C73GRB-6106A                  | DPL             | T1-R1  | TONE         |
| C73GRB-6115A                  | DPL             | T2-R1  | DC           |
| C73GRB-6116A                  | DPL             | T2-R1  | TONE         |
| C73GRB-6125A                  | DPL             | T2-R2  | DC           |
| C73GRB-6126A                  | DPL             | T2-R2  | TONE         |
| <b>REPEATER (RT) STATIONS</b> |                 |  |              |
| C73GSB-1105A                  | CARRIER         | T1-R1  | DC           |
| C73GSB-1106A                  | CARRIER         | T1-R1  | TONE         |
| C73GSB-1115A                  | CARRIER         | T2-R1  | DC           |
| C73GSB-1116A                  | CARRIER         | T2-R1  | TONE         |
| C73GSB-1125A                  | CARRIER         | T2-R2  | DC           |
| C73GSB-1126A                  | CARRIER         | T2-R2  | TONE         |
| C73GSB-1145A                  | CARRIER         | T2-2R  | DC           |
| C73GSB-1146A                  | CARRIER         | T2-2R  | TONE         |
| C73GSB-1196A                  | CARRIER         | T4-R4  | TONE         |
| C73GSB-3105A                  | PL              | T1-R1  | DC           |
| C73GSB-3106A                  | PL              | T1-R1  | TONE         |
| C73GSB-3115A                  | PL              | T2-R1  | DC           |
| C73GSB-3116A                  | PL              | T2-R1  | TONE         |
| C73GSB-3125A                  | PL              | T2-R2  | DC           |
| C73GSB-3126A                  | PL              | T2-R2  | TONE         |
| C73GSB-3145A                  | PL              | T2-2R  | DC           |
| C73GSB-3146A                  | PL              | T2-2R  | TONE         |
| C73GSB-3196A                  | PL              | T4-R4  | TONE         |
| C73GSB-6105A                  | DPL             | T1-R1  | DC           |
| C73GSB-6106A                  | DPL             | T1-R1  | TONE         |
| C73GSB-6115A                  | DPL             | T2-R1  | DC           |
| C73GSB-6116A                  | DPL             | T2-R1  | TONE         |
| C73GSB-6125A                  | DPL             | T2-R2  | DC           |
| C73GSB-6126A                  | DPL             | T2-R2  | TONE         |
| C73GSB-6145A                  | DPL             | T2-2R  | DC           |
| C73GSB-6146A                  | DPL             | T2-2R  | TONE         |
| C73GSB-6196A                  | DPL             | T4-R4  | TONE         |
| <b>REPEATER (RT) STATIONS</b> |                 |  |              |
| C73GSB-1105AT                 | CARRIER         | T1-R1  | DC           |
| C73GSB-1106AT                 | CARRIER         | T1-R1  | TONE         |
| C73GSB-3105AT                 | PL              | T1-R1  | DC           |
| C73GSB-3106AT                 | PL              | T1-R1  | TONE         |
| C73GSB-6105AT                 | DPL             | T1-R1  | DC           |
| C73GSB-6106AT                 | DPL             | T1-R1  | TONE         |

**CODE:**  
● = ONE ITEM SUPPLIED  
2 = INDICATES QUANTITY SUPPLIED  
★ = USED IN PLACE OF ONE 10.7 MHz IF RECEIVER ON TWO RECEIVER STATIONS WITH CERTAIN FREQUENCY COMBINATIONS

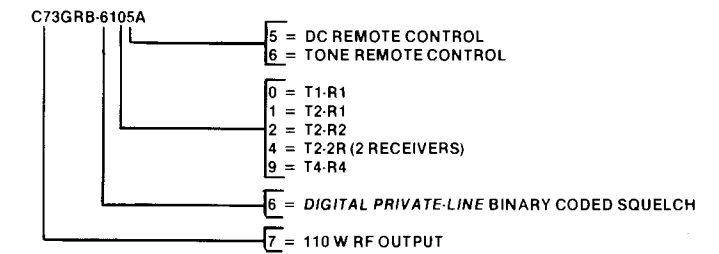

# MODEL BREAKDOWN CHART

FOR

**MSR 2000**

INTERMITTENT DUTY

BASE/REPEATER (RT) STATIONS

146-174 MHz

110 W RF POWER OUTPUT

EARLIER VERSION

**CODE:**

● = ONE ITEM SUPPLIED

2,4 = INDICATES QUANTITY SUPPLIED

| ITEM     | DESCRIPTION                                   |
|----------|---|
| TLD2502A | DUPLEXER                                      |
| TLD2532A | 110 WATT/160 WATT VARIABLE POWER PA DECK      |
| TLN2442A | SINGLE-TONE DECODER MODULE                    |
| TLN2443A | GUARD TONE DECODER MODULE                     |
| TLN2444A | F2 TONE DECODER MODULE (C2-R2 CONTROL)        |
| TLN2445A | SQUELCH CONTROL TONE DECODER MODULE           |
| TLN2446A | REPEATER CONTROL TONE DECODER MODULE          |
| TLN2447A | PRIVATE-LINE CONTROL TONE DECODER MODULE      |
| TLN2448A | "WILD CARD" TONE DECODER CONTROL MODULE       |
| TLN2449A | F2 TONE DECODER MODULE (PAGING CONTROL)       |
| TLN2450A | GUARD TONE DECODER MODULE (GT RELAY CONTROL)  |
| TLN2472B | BASIC CONTROL CHASSIS                         |
| TLN2473B | FULLY OPTIONAL CONTROL CHASSIS (1-RCVR. BASE) |
| TLN2474B | FULLY OPTIONAL CONTROL CHASSIS (2-RCVR. BASE) |
| TLN2475B | FULLY OPTIONAL CONTROL CHASSIS (REPEATER RT)  |
| TPN1191A | STANDARD POWER SUPPLY                         |
| TPN1192A | BATTERY CHARGER POWER SUPPLY                  |
| TLN2515A | FULLY OPTIONAL CONTROL CHASSIS (41-BASE)      |

| ITEM       | DESCRIPTION                                     |
|------------|---|
| KLN6209A   | VIBRASPOUNDER RESONANT REED                     |
| TFD6452A   | HARMONIC FILTER                                 |
| TKN6471A   | CABLE   |
| TKN8292A   | CABLE   |
| TKN8293A   | CABLE   |
| TLD8392A   | FILTER CIRCUIT                                  |
| TLD9252A   | POWER AMPLIFIER BOARD                           |
| TLD9272A   | POWER CONTROL BOARD                             |
| TPN1189A   | AUXILIARY REGULATOR CHASSIS                     |
| INCLDS.    | TRN5119A AUXILIARY REGULATOR BOARD              |
| INCLDS.    | TRN5297A HARDWARE KIT                           |
| INCLDS.    | TRN5299A CHASSIS KIT                            |
| TPN1190A   | AUXILIARY REGULATOR CHASSIS WITH BATTERY OPTION |
| INCLDS.    | TRN5119A AUXILIARY REGULATOR BOARD              |
| INCLDS.    | TRN5120A BATTERY REVERT CONTROL BOARD           |
| INCLDS.    | TRN5298A HARDWARE                               |
| INCLDS.    | TRN5299A CHASSIS                                |
| TPN6137A   | BATTERY CHARGER BOARD                           |
| TPN6138A   | DISTRIBUTION BOARD                              |
| TRN5081A,B | BACKPLANE INTERCONNECT BOARD (BASIC)            |
| TRN5082A,B | BACKPLANE INTERCONNECT BOARD (1-RECEIVER)       |
| TRN5083A,B | BACKPLANE INTERCONNECT BOARD (DUPLEX)           |
| TRN5084A,B | BACKPLANE INTERCONNECT BOARD (2-RECEIVERS)      |
| TRN5141A   | PA HARDWARE                                     |
| TRN5153A   | BATTERY CHARGER HARDWARE                        |
| TRN5305A   | TONE DECODER BOARD, SINGLE-TONE CONTROL         |
| TRN5306A   | SINGLE-TONE CONTROL PANEL                       |
| TRN5307A   | TONE DECODER MODULE, GT                         |
| TRN5308A   | TONE DECODER BOARD, C2-R2 CONTROL               |
| TRN5309A   | C2-R2 CONTROL PANEL                             |
| TRN5310A   | TONE DECODER BOARD                              |
| TRN5311A   | SQUELCH CONTROL PANEL                           |
| TRN5312A   | REPEATER CONTROL PANEL                          |
| TRN5313A   | PRIVATE-LINE CONTROL PANEL                      |
| TRN5315A   | TONE DECODER BOARD, "WILD CARD" CONTROL         |
| TRN5316A   | "WILD CARD" CONTROL PANEL                       |
| TRN5317A   | TONE DECODER BOARD, PAGING CONTROL              |
| TRN5318A   | PAGING CONTROL PANEL                            |
| TRN5319A   | TONE DECODER MODULE, GT RELAY CONTROL           |
| TRN5335A   | INTERCONNECT HARDWARE                           |
| TRN5336A   | 500 WATT POWER SUPPLY HARDWARE                  |
| TRN5362A   | INTERCONNECT HARDWARE                           |
| TRN5378A   | CLOSING HARDWARE                                |
| TRN5432A   | HARDWARE (BASIC)                                |
| TRN5433A   | HARDWARE (1-RECEIVER)                           |
| TRN5434A   | HARDWARE (2-RECEIVERS)                          |
| TRN5445A   | HARDWARE, MTG (DUPLEXER)                        |
| TRN5462A,B | BACKPLANE INTERCONNECT BOARD                    |
| TRN5464A   | TONE DECODER BOARD                              |
| TRN5465A   | TONE DECODER BOARD                              |
| TKN8313A   | CABLE INTERNAL PA                               |

GRB "B" SUFFIX MODELS (BASIC)  
 GSB "B" MODELS  
 (FULLY OPTIONALABLE)  
 MODEL CHART  
 FOR  
 MSR 2000  
 INTERMITTENT DUTY  
 BASE REPEATER (RT) STATIONS  
 146-174MHZ 110 WATT RF POWER OUTPUT  
 LATER VERSION

CODE:  
 ● = ONE ITEM SUPPLIED  
 2 = INDICATES QUANTITY SUPPLIED  
 / = USED IN PLACE OF ONE  
 10.7MHZ 1-F RECEIVER STATIONS  
 WITH CERTAIN FREQUENCY COMBINATIONS

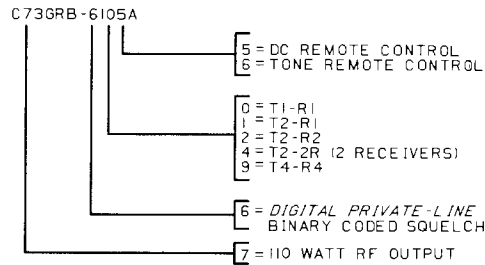

| STATION MODEL        | TYPE OF SQUELCH | CONTROL TYPE | MODEL |             | DESCRIPTION                                  |
|----------------------|-----------------|--------------|-------|-------------|--|
|                      |                 |              | MODEL | DESCRIPTION |  |
| <b>BASE STATIONS</b> |                 |              |       |             |  |
| C736RB-1105B         | CARRIER         | T1-R1        | ●     | ●           | V/BRESPONDER RESONANT REED                   |
| C736RB-1106B         | CARRIER         | T1-R1        | ●     | ●           | RECEIVE ELEMENT 10.7MHZ 1-F) 5PPM            |
| C736RB-1115B         | CARRIER         | T2-R1        | ●     | ●           | RECEIVE ELEMENT 10.8MHZ 1-F) 5PPM            |
| C736RB-1116B         | CARRIER         | T2-R1        | ●     | ●           | TRANSMIT ELEMENT 5PPM                        |
| C736RB-1125B         | CARRIER         | T2-R2        | ●     | ●           | STATION INTERCONNECT CABLE                   |
| C736RB-1126B         | CARRIER         | T2-R2        | ●     | ●           | TWO-WIRE LINE CABLE                          |
| C736RB-3105B         | PL              | T1-R1        | ●     | ●           | PA POWER/EXCITER CABLE                       |
| C736RB-3106B         | PL              | T1-R1        | ●     | ●           | NON-DUPLEXER CABLES                          |
| C736RB-3115B         | PL              | T2-R1        | ●     | ●           | 110 W PA                                     |
| C736RB-3116B         | PL              | T2-R1        | ●     | ●           | SIMPLEX EXCITER                              |
| C736RB-3125B         | PL              | T2-R2        | ●     | ●           | DUPLEX EXCITER                               |
| C736RB-3126B         | PL              | T2-R2        | ●     | ●           | GUARD TONE DECODER MODULE                    |
| C736RB-6105B         | DPL             | T1-R1        | ●     | ●           | C2-R2 F2 TONE DECODER MODULE                 |
| C736RB-6106B         | DPL             | T1-R1        | ●     | ●           | BASIC CHASSIS                                |
| C736RB-6115B         | DPL             | T2-R1        | ●     | ●           | FULLY OPTIONALABLE CHASSIS (2 REC)           |
| C736RB-6116B         | DPL             | T2-R1        | ●     | ●           | FULLY OPTIONALABLE CHASSIS (REPEATER RT)     |
| C736RB-6125B         | DPL             | T2-R2        | ●     | ●           | STANDARD POWER SUPPLY                        |
| C736RB-6126B         | DPL             | T2-R2        | ●     | ●           | RECEIVER 10.7MHZ NON-FILTERED                |
| C736RB-1105B         | CARRIER         | T1-R1        | ●     | ●           | RECEIVER 10.7MHZ FILTERED                    |
| C736RB-1106B         | CARRIER         | T1-R1        | ●     | ●           | RECEIVER 10.8MHZ FILTERED                    |
| C736RB-1115B         | CARRIER         | T2-R1        | ●     | ●           | 2 RECEIVER COUPLER                           |
| C736RB-1116B         | CARRIER         | T2-R1        | ●     | ●           | R1 AUDIO BOARD                               |
| C736RB-1125B         | CARRIER         | T2-R2        | ●     | ●           | R2 AUDIO BOARD                               |
| C736RB-1126B         | CARRIER         | T2-R2        | ●     | ●           | R2 AUDIO PL BOARD                            |
| C736RB-3105B         | PL              | T1-R1        | ●     | ●           | DUPLEX PL BOARD                              |
| C736RB-3106B         | PL              | T1-R1        | ●     | ●           | SIMPLEX PL TA-RA BOARD                       |
| C736RB-3115B         | PL              | T2-R1        | ●     | ●           | DUPLEX DPL BOARD                             |
| C736RB-3116B         | PL              | T2-R1        | ●     | ●           | SIMPLEX DPL, TA-RA BOARD                     |
| C736RB-3125B         | PL              | T2-R2        | ●     | ●           | ANTENNA RELAY                                |
| C736RB-3126B         | PL              | T2-R2        | ●     | ●           | 1 RECEIVER, 2-WIRE AUDIO: LINE DRIVER MODULE |
| C736RB-6105B         | DPL             | T1-R1        | ●     | ●           | 2 RECEIVER, 2-WIRE AUDIO: LINE DRIVER MODULE |
| C736RB-6106B         | DPL             | T1-R1        | ●     | ●           | F1 PL CONTROL MODULE                         |
| C736RB-6115B         | DPL             | T2-R1        | ●     | ●           | F1 PL CONTROL MODULE                         |
| C736RB-6116B         | DPL             | T2-R1        | ●     | ●           | F2-R2 CONTROL MODULE                         |
| C736RB-6125B         | DPL             | T2-R2        | ●     | ●           | F2-R2 MUTE CONTROL MODULE                    |
| C736RB-6126B         | DPL             | T2-R2        | ●     | ●           | CMOS TIME-OUT TIMER                          |
| C736RB-1105B         | CARRIER         | T1-R1        | ●     | ●           | 4-FREQUENCY CONTROL MODULE                   |
| C736RB-1106B         | CARRIER         | T1-R1        | ●     | ●           | F1 PL TONE DECODER MODULE                    |
| C736RB-1115B         | CARRIER         | T2-R1        | ●     | ●           | F1 PL TONE DECODER MODULE                    |
| C736RB-1116B         | CARRIER         | T2-R1        | ●     | ●           | STATION CONTROL MODULE                       |
| C736RB-1125B         | CARRIER         | T2-R2        | ●     | ●           | F1 TONE DECODER MODULE                       |
| C736RB-1126B         | CARRIER         | T2-R2        | ●     | ●           | SQUELCH GATE MODULE                          |
| C736RB-3105B         | PL              | T1-R1        | ●     | ●           | F2 TONE DECODER MODULE                       |
| C736RB-3106B         | PL              | T1-R1        | ●     | ●           | 4F F1 PL TONE DECODER MODULE                 |
| C736RB-3115B         | PL              | T2-R1        | ●     | ●           | SIMPLEX JUNCTION BOX                         |
| C736RB-3116B         | PL              | T2-R1        | ●     | ●           | DUPLEX JUNCTION BOX                          |
| C736RB-3125B         | PL              | T2-R2        | ●     | ●           | RF PLASTIC PLUG                              |
| C736RB-3126B         | PL              | T2-R2        | ●     | ●           | 0-TYPE CONNECTOR PLASTIC PLUG                |
| C736RB-6105B         | DPL             | T1-R1        | ●     | ●           | BATTERY PLASTIC PLUG                         |
| C736RB-6106B         | DPL             | T1-R1        | ●     | ●           | 24" CABINET HARDWARE                         |
| C736RB-6115B         | DPL             | T2-R1        | ●     | ●           | 110 V POWER CORD                             |
| C736RB-6116B         | DPL             | T2-R1        | ●     | ●           | INTERMITTENT PA HARDWARE                     |
| C736RB-6125B         | DPL             | T2-R2        | ●     | ●           | BASIC COVERS                                 |
| C736RB-6126B         | DPL             | T2-R2        | ●     | ●           | OPTIONAL COVERS                              |
| C736RB-1105B         | CARRIER         | T1-R1        | ●     | ●           | REPEATER COVERS                              |
| C736RB-1106B         | CARRIER         | T1-R1        | ●     | ●           | DUPLEX RF COVER                              |
| C736RB-1115B         | CARRIER         | T2-R1        | ●     | ●           | DPL CODE PLUG                                |
| C736RB-1116B         | CARRIER         | T2-R1        | ●     | ●           | HARDWARE OPT CONTROL R2                      |
| C736RB-1125B         | CARRIER         | T2-R2        | ●     | ●           |  |
| C736RB-1126B         | CARRIER         | T2-R2        | ●     | ●           |  |
| C736RB-3105B         | PL              | T1-R1        | ●     | ●           |  |
| C736RB-3106B         | PL              | T1-R1        | ●     | ●           |  |
| C736RB-3115B         | PL              | T2-R1        | ●     | ●           |  |
| C736RB-3116B         | PL              | T2-R1        | ●     | ●           |  |
| C736RB-3125B         | PL              | T2-R2        | ●     | ●           |  |
| C736RB-3126B         | PL              | T2-R2        | ●     | ●           |  |
| C736RB-6105B         | DPL             | T1-R1        | ●     | ●           |  |
| C736RB-6106B         | DPL             | T1-R1        | ●     | ●           |  |
| C736RB-6115B         | DPL             | T2-R1        | ●     | ●           |  |
| C736RB-6116B         | DPL             | T2-R1        | ●     | ●           |  |
| C736RB-6125B         | DPL             | T2-R2        | ●     | ●           |  |
| C736RB-6126B         | DPL             | T2-R2        | ●     | ●           |  |
| C736RB-1105B         | CARRIER         | T1-R1        | ●     | ●           |  |
| C736RB-1106B         | CARRIER         | T1-R1        | ●     | ●           |  |
| C736RB-1115B         | CARRIER         | T2-R1        | ●     | ●           |  |
| C736RB-1116B         | CARRIER         | T2-R1        | ●     | ●           |  |
| C736RB-1125B         | CARRIER         | T2-R2        | ●     | ●           |  |
| C736RB-1126B         | CARRIER         | T2-R2        | ●     | ●           |  |
| C736RB-3105B         | PL              | T1-R1        | ●     | ●           |  |
| C736RB-3106B         | PL              | T1-R1        | ●     | ●           |  |
| C736RB-3115B         | PL              | T2-R1        | ●     | ●           |  |
| C736RB-3116B         | PL              | T2-R1        | ●     | ●           |  |
| C736RB-3125B         | PL              | T2-R2        | ●     | ●           |  |
| C736RB-3126B         | PL              | T2-R2        | ●     | ●           |  |
| C736RB-6105B         | DPL             | T1-R1        | ●     | ●           |  |
| C736RB-6106B         | DPL             | T1-R1        | ●     | ●           |  |
| C736RB-6115B         | DPL             | T2-R1        | ●     | ●           |  |
| C736RB-6116B         | DPL             | T2-R1        | ●     | ●           |  |
| C736RB-6125B         | DPL             | T2-R2        | ●     | ●           |  |
| C736RB-6126B         | DPL             | T2-R2        | ●     | ●           |  |
| C736RB-1105B         | CARRIER         | T1-R1        | ●     | ●           |  |
| C736RB-1106B         | CARRIER         | T1-R1        | ●     | ●           |  |
| C736RB-1115B         | CARRIER         | T2-R1        | ●     | ●           |  |
| C736RB-1116B         | CARRIER         | T2-R1        | ●     | ●           |  |
| C736RB-1125B         | CARRIER         | T2-R2        | ●     | ●           |  |
| C736RB-1126B         | CARRIER         | T2-R2        | ●     | ●           |  |
| C736RB-3105B         | PL              | T1-R1        | ●     | ●           |  |
| C736RB-3106B         | PL              | T1-R1        | ●     | ●           |  |
| C736RB-3115B         | PL              | T2-R1        | ●     | ●           |  |
| C736RB-3116B         | PL              | T2-R1        | ●     | ●           |  |
| C736RB-3125B         | PL              | T2-R2        | ●     | ●           |  |
| C736RB-3126B         | PL              | T2-R2        | ●     | ●           |  |
| C736RB-6105B         | DPL             | T1-R1        | ●     | ●           |  |
| C736RB-6106B         | DPL             | T1-R1        | ●     | ●           |  |
| C736RB-6115B         | DPL             | T2-R1        | ●     | ●           |  |
| C736RB-6116B         | DPL             | T2-R1        | ●     | ●           |  |
| C736RB-6125B         | DPL             | T2-R2        | ●     | ●           |  |
| C736RB-6126B         | DPL             | T2-R2        | ●     | ●           |  |
| C736RB-1105B         | CARRIER         | T1-R1        | ●     | ●           |  |
| C736RB-1106B         | CARRIER         | T1-R1        | ●     | ●           |  |
| C736RB-1115B         | CARRIER         | T2-R1        | ●     | ●           |  |
| C736RB-1116B         | CARRIER         | T2-R1        | ●     | ●           |  |
| C736RB-1125B         | CARRIER         | T2-R2        | ●     | ●           |  |
| C736RB-1126B         | CARRIER         | T2-R2        | ●     | ●           |  |
| C736RB-3105B         | PL              | T1-R1        | ●     | ●           |  |
| C736RB-3106B         | PL              | T1-R1        | ●     | ●           |  |
| C736RB-3115B         | PL              | T2-R1        | ●     | ●           |  |
| C736RB-3116B         | PL              | T2-R1        | ●     | ●           |  |
| C736RB-3125B         | PL              | T2-R2        | ●     | ●           |  |
| C736RB-3126B         | PL              | T2-R2        | ●     | ●           |  |
| C736RB-6105B         | DPL             | T1-R1        | ●     | ●           |  |
| C736RB-6106B         | DPL             | T1-R1        | ●     | ●           |  |
| C736RB-6115B         | DPL             | T2-R1        | ●     | ●           |  |
| C736RB-6116B         | DPL             | T2-R1        | ●     | ●           |  |
| C736RB-6125B         | DPL             | T2-R2        | ●     | ●           |  |
| C736RB-6126B         | DPL             | T2-R2        | ●     | ●           |  |
| C736RB-1105B         | CARRIER         | T1-R1        | ●     | ●           |  |
| C736RB-1106B         | CARRIER         | T1-R1        | ●     | ●           |  |
| C736RB-1115B         | CARRIER         | T2-R1        | ●     | ●           |  |
| C736RB-1116B         | CARRIER         | T2-R1        | ●     | ●           |  |
| C736RB-1125B         | CARRIER         | T2-R2        | ●     | ●           |  |
| C736RB-1126B         | CARRIER         | T2-R2        | ●     | ●           |  |
| C736RB-3105B         | PL              | T1-R1        | ●     | ●           |  |
| C736RB-3106B         | PL              | T1-R1        | ●     | ●           |  |
| C736RB-3115B         | PL              | T2-R1        | ●     | ●           |  |
| C736RB-3116B         | PL              | T2-R1        | ●     | ●           |  |
| C736RB-3125B         | PL              | T2-R2        | ●     | ●           |  |
| C736RB-3126B         | PL              | T2-R2        | ●     | ●           |  |
| C736RB-6105B         | DPL             | T1-R1        | ●     | ●           |  |
| C736RB-6106B         | DPL             | T1-R1        | ●     | ●           |  |
| C736RB-6115B         | DPL             | T2-R1        | ●     | ●           |  |
| C736RB-6116B         | DPL             | T2-R1        | ●     | ●           |  |
| C736RB-6125B         | DPL             | T2-R2        | ●     | ●           |  |
| C736RB-6126B         | DPL             | T2-R2        | ●     | ●           |  |
| C736RB-1105B         | CARRIER         | T1-R1        | ●     | ●           |  |
| C736RB-1106B         | CARRIER         | T1-R1        | ●     | ●           |  |
| C736RB-1115B         | CARRIER         | T2-R1        | ●     | ●           |  |
| C736RB-1116B         | CARRIER         | T2-R1        | ●     | ●           |  |
| C736RB-1125B         | CARRIER         | T2-R2        | ●     | ●           |  |
| C736RB-1126B         | CARRIER         | T2-R2        | ●     | ●           |  |
| C736RB-3105B         | PL              | T1-R1        | ●     | ●           |  |
| C736RB-3106B         | PL              | T1-R1        | ●     | ●           |  |
| C736RB-3115B         | PL              | T2-R1        | ●     | ●           |  |
| C736RB-3116B         | PL              | T2-R1        | ●     | ●           |  |
| C736RB-3125B         | PL              | T2-R2        | ●     | ●           |  |
| C736RB-3126B         | PL              | T2-R2        | ●     | ●           |  |
| C736RB-6105B         | DPL             | T1-R1        | ●     | ●           |  |
| C736RB-6106B         | DPL             | T1-R1        | ●     | ●           |  |
| C736RB-6115B         | DPL             | T2-R1        | ●     | ●           |  |
| C736RB-6116B         | DPL             | T2-R1        | ●     | ●           |  |
| C736RB-6125B         | DPL             | T2-R2        | ●     | ●           |  |
| C736RB-6126B         | DPL             | T2-R2        | ●     | ●           |  |
| C736RB-1105B         | CARRIER         | T1-R1        | ●     | ●           |  |
| C736RB-1106B         | CARRIER         | T1-R1        | ●     | ●           |  |
| C736RB-1115B         | CARRIER         | T2-R1        | ●     | ●           |  |
| C736RB-1116B         | CARRIER         | T2-R1        | ●     | ●           |  |
| C736RB-1125B         | CARRIER         | T2-R2        | ●     | ●           |  |
| C736RB-1126B         | CARRIER         | T2-R2        | ●     | ●           |  |
| C736RB-3105B         | PL              | T1-R1        | ●     | ●           |  |
| C736RB-3106B         | PL              | T1-R1        | ●     | ●           |  |
| C736RB-3115B         | PL              | T2-R1        | ●     | ●           |  |
| C736RB-3116B         | PL              | T2-R1        | ●     | ●           |  |
| C736RB-3125B         | PL              | T2-R2        | ●     | ●           |  |
| C736RB-3126B         | PL              | T2-R2        | ●     | ●           |  |
| C736RB-6105B         | DPL             | T1-R1        | ●     | ●           |  |
| C736RB-6106B         | DPL             | T1-R1        | ●     | ●           |  |
| C736RB-6115B         | DPL             | T2-R1        | ●     | ●           |  |
| C736RB-6116B         | DPL             | T2-R1        | ●     | ●           |  |
| C736RB-6125B         | DPL             | T2-R2        | ●     | ●           |  |
| C736RB-6126B         | DPL             | T2-R2        | ●     | ●           |  |
| C736RB-1105B         | CARRIER         | T1-R1        | ●     | ●           |  |
| C736RB-1106B         | CARRIER         | T1-R1        | ●     | ●           |  |
| C736RB-1115B         | CARRIER         | T2-R1        | ●     | ●           |  |
| C736RB-1116B         | CARRIER         | T2-R1        | ●     | ●           |  |
| C736RB-1125B         | CARRIER         | T2-R2        | ●     | ●           |  |
| C736RB-1126B         | CARRIER         | T2-R2        | ●     | ●           |  |
| C736RB-3105B         | PL              | T1-R1        | ●     | ●           |  |
| C736RB-3106B         | PL              | T1-R1        | ●     | ●           |  |
| C736RB-3115B         | PL              | T2-R1        | ●     | ●           |  |
| C736RB-3116B         | PL              | T2-R1        | ●     | ●           |  |
| C736RB-3125B         | PL              | T2-R2        | ●     | ●           |  |
| C736RB-3126B         | PL              | T2-R2        | ●     | ●           |  |
| C736RB-6105B         | DPL             | T1-R1        | ●     | ●           |  |
| C736RB-6106B         | DPL             | T1-R1        | ●     | ●           |  |
| C736RB-6115B         | DPL             | T2-R1        | ●     | ●           |  |
| C736RB-6116B         | DPL             |              |       |             |  |

MODEL BREAKDOWN CHART  
FOR  
**MSR 2000**  
INTERMITTENT DUTY  
BASE/REPEATER (RT) STATIONS  
146-174MHZ 110 WATT RF POWER OUTPUT  
LATER VERSION

CODE :

- = ONE ITEM SUPPLIED
- 2,4 = INDICATES QUANTITY SUPPLIED

| ITEM     | DESCRIPTION  | ITEM       | DESCRIPTION                                     |
|----------|--|------------|---|
| TL02502A | DUPLEXER   | KN6209A    | VIBRASPOUNDER RESONANT REED                     |
| TL02532A | 110 WATT/60 WATT VARIABLE POWER PA DECK              | TF06452A   | HARMONIC FILTER                                 |
| TLN2442A | SINGLE TONE DECODER                                  | TKN6471A   | CABLE   |
| TLN2443A | GUARD TONE DECODER MODULE                            | TKN8292A   | CABLE   |
| TLN2444A | F2 TONE DECODER MODULE (C2-R2 CONTROL)               | TKN8299A   | CABLE   |
| TLN2445A | SQUELCH CONTROL TONE DECODER MODULE                  | TL08392A   | FILTER CIRCUIT                                  |
| TLN2446A | REPEATER CONTROL TONE DECODER MODULE                 | TL09252A   | POWER AMPLIFIER BOARD                           |
| TLN2447A | PRIVATE-LINE CONTROL TONE DECODER MODULE             | TL09272A   | POWER CONTROL BOARD                             |
| TLN2448A | "WILD CARD" TONE DECODER CONTROL MODULE              | TPN1193A   | AUXILIARY REGULATOR CHASSIS                     |
| TLN2449A | F2 TONE DECODER CONTROL MODULE (PAGING CONTROL)      | INCL05     | TRN5119A AUXILIARY REGULATOR BOARD              |
| TLN2450A | GUARD TONE DECODER MODULE (GUARD TONE RELAY CONTROL) | INCL05     | TRN5297A HARDWARE KIT                           |
| TLN2472B | BASIC CONTROL CHASSIS                                | INCL05     | TRN5299A CHASSIS KIT                            |
| TLN2474B | FULLY OPTIONABLE CONTROL CHASSIS (2-RCVR BASE)       | TPN1190A   | AUXILIARY REGULATOR CHASSIS WITH BATTERY OPTION |
| TLN2475B | FULLY OPTIONABLE CONTROL CHASSIS (REPEATER RT)       | INCL05     | TRN5119A AUXILIARY REGULATOR BOARD              |
| TPN1191A | STANDARD POWER SUPPLY                                | INCL05     | TRN5120A BATTERY REVERT CONTROL BOARD           |
| TPN1192A | BATTERY CHARGER POWER SUPPLY                         | INCL05     | TRN5298A HARDWARE                               |
|          |  | INCL05     | TRN5299A CHASSIS                                |
|          |  | TPN6137A   | BATTERY CHARGER BOARD                           |
|          |  | TPN6138A   | DISTRIBUTION BOARD                              |
|          |  | TRN5081A,B | BACKPLANE INTERCONNECT BOARD (BASIC)            |
|          |  | TRN5082A,B | BACKPLANE INTERCONNECT BOARD (I-RECEIVER)       |
|          |  | TRN5083A,B | BACKPLANE INTERCONNECT BOARD (DUPEX)            |
|          |  | TRN5084A,B | BACKPLANE INTERCONNECT BOARD (2-RECEIVERS)      |
|          |  | TRN5141A   | PA HARDWARE                                     |
|          |  | TRN5153A   | BATTERY CHARGER HARDWARE                        |
|          |  | TRN5305A   | TONE DECODER BOARD, SINGLE-TONE CONTROL         |
|          |  | TRN5308A   | SINGLE-TONE CONTROL PANEL                       |
|          |  | TRN5307A   | TONE DECODER BOARD,C2-R2 CONTROL                |
|          |  | TRN5308A   | C2-R2 CONTROL PANEL                             |
|          |  | TRN5309A   | TONE DECODER BOARD, SINGLE-TONE CONTROL         |
|          |  | TRN5310A   | TONE DECODER BOARD                              |
|          |  | TRN5311A   | SQUELCH CONTROL PANEL                           |
|          |  | TRN5312A   | REPEATER CONTROL PANEL                          |
|          |  | TRN5313A   | PRIVATE-LINE CONTROL PANEL                      |
|          |  | TRN5315A   | TONE DECODER BOARD "WILD CARD" CONTROL          |
|          |  | TRN5316A   | "WILD CARD" CONTROL PANEL                       |
|          |  | TRN5317A   | TONE DECODER BOARD, PAGING CONTROL              |
|          |  | TRN5318A   | PAGING CONTROL PANEL                            |
|          |  | TRN5319A   | TONE DECODER MODULE, GUARD TONE RELAY CONTROL   |
|          |  | TRN5335A   | INTERCONNECT HARDWARE                           |
|          |  | TRN5336A   | 500 WATT POWER SUPPLY HARDWARE                  |
|          |  | TRN5362A   | INTERCONNECT HARDWARE                           |
|          |  | TRN5378A   | CLOSING HARDWARE                                |
|          |  | TRN5432A   | HARDWARE, BASIC                                 |
|          |  | TRN5433A   | HARDWARE (I-RECEIVER)                           |
|          |  | TRN5445A   | HARDWARE, MTG. (DUPEXER)                        |
|          |  | TRN5464A   | TONE DECODER BOARD                              |
|          |  | TRN5465A   | TONE DECODER BOARD                              |
|          |  | TKN8313A   | CABLE INTERNAL PA                               |

EEPS-42181-0



**MODEL BREAKDOWN CHART  
FOR  
MSR 2000  
CONTINUOUS DUTY  
BASE/REPEATER (RT) STATIONS  
132-174 MHz 100 WATT POWER OUTPUT  
EARLIER VERSION**

**CODE:**

● = ONE ITEM SUPPLIED  
2,4 = INDICATES QUANTITY SUPPLIED

| ITEM       | DESCRIPTION                                     |
|------------|---|
| KLN6209A   | VIBRASPOUNDER RESONANT REED                     |
| TFD6101A   | HARMONIC FILTER, 132-150.8 MHz                  |
| TFD6102A   | HARMONIC FILTER, 150.8-174 MHz                  |
| TKN6471A   | CABLE   |
| TKN8292A   | CABLE   |
| TKN8293A   | CABLE   |
| TLD5952A   | POWER AMPLIFIER BOARD 132-150.8 MHz             |
| TLD5953A   | POWER AMPLIFIER BOARD 150.8-162 MHz             |
| TLD5954A   | POWER AMPLIFIER BOARD 162-174 MHz               |
| TLD5960A   | POWER CONTROL BOARD                             |
| TLD6392A   | FILTER CIRCUIT                                  |
| TLN2424A   | POWER AMPLIFIER INPUT BRACKET ASSEMBLY          |
| INCLDS     | TRN5566A PA INPUT BRACKET                       |
| INCLDS     | TRN5585A EXCITER CONTROL VOLTAGE REGULATOR      |
| INCLDS     | TKN8336A PA CABLE KIT                           |
| TPN1189A   | AUXILIARY REGULATOR CHASSIS                     |
| INCLDS     | TRN5119A AUXILIARY REGULATOR BOARD              |
| INCLDS     | TRN5297A HARDWARE KIT                           |
| INCLDS     | TRN5298A CHASSIS KIT                            |
| TPN1190A   | AUXILIARY REGULATOR CHASSIS WITH BATTERY OPTION |
| INCLDS     | TRN5119A AUXILIARY REGULATOR BOARD              |
| INCLDS     | TRN5120A BATTERY REVERT CONTROL BOARD           |
| INCLDS     | TRN5298A HARDWARE                               |
| INCLDS     | TRN5299A CHASSIS                                |
| TPN6137A   | BATTERY CHARGER BOARD                           |
| TPN6138A   | DISTRIBUTION BOARD                              |
| TRN5081A,B | BACKPLANE INTERCONNECT BOARD (BASIC)            |
| TRN5082A,B | BACKPLANE INTERCONNECT BOARD (1-RECEIVER)       |
| TRN5083A,B | BACKPLANE INTERCONNECT BOARD (DUPLX)            |
| TRN5084A,B | BACKPLANE INTERCONNECT BOARD (2-RECEIVERS)      |
| TRN5153A   | BATTERY CHARGER HARDWARE                        |
| TRN5305A   | TONE DECODER BOARD, SINGLE-TONE CONTROL         |
| TRN5306A   | SINGLE-TONE CONTROL PANEL                       |
| TRN5307A   | TONE DECODER MODULE, GUARD TONE                 |
| TRN5308A   | TONE DECODER BOARD, C2-R2 CONTROL               |
| TRN5309A   | C2-R2 CONTROL PANEL                             |
| TRN5310A   | TONE DECODER BOARD                              |
| TRN5311A   | SQUELCH CONTROL PANEL                           |
| TRN5312A   | REPEATER CONTROL PANEL                          |
| TRN5313A   | PRIVATE-LINE CONTROL PANEL                      |
| TRN5315A   | TONE DECODER BOARD "WILD CARD" CONTROL          |
| TRN5316A   | "WILD CARD" CONTROL PANEL                       |
| TRN5317A   | TONE DECODER BOARD, PAGING CONTROL              |
| TRN5318A   | PAGING CONTROL PANEL                            |
| TRN5319A   | TONE DECODER MODULE, GUARD TONE RELAY CONTROL   |
| TRN5335A   | INTERCONNECT HARDWARE                           |
| TRN5336A   | 500 WATT POWER SUPPLY HARDWARE                  |
| TRN5362A   | INTERCONNECT HARDWARE                           |
| TRN5432A   | HARDWARE, BASIC                                 |
| TRN5433A   | HARDWARE (1-RECEIVER)                           |
| TRN5434A   | HARDWARE (2-RECEIVERS)                          |
| TRN5435A   | HARDWARE (DUPLX)                                |
| TRN5445A   | HARDWARE (DUPLXER MOUNTING)                     |
| TRN5462A,B | BACKPLANE INTERCONNECT BOARD                    |
| TRN5464A   | TONE DECODER BOARD                              |
| TRN5465A   | TONE DECODER BOARD                              |
| TRN5577A   | PA CASTING & HARDWARE                           |
| TRN5586A   | PA HARDWARE                                     |
| TRN8089A   | SUPPRESSION NETWORK                             |

| ITEM     | DESCRIPTION  |
|----------|--|
| TLD2502A | DUPLEXER   |
| TLD2601A | 100 WATT/50 WATT VARIABLE PA DECK, 132-150.8 MHz     |
| TLD2602A | 100 WATT/50 WATT VARIABLE PA DECK, 150.8-162 MHz     |
| TLD2603A | 100 WATT/50 WATT VARIABLE PA DECK, 162-174 MHz       |
| TLN2442A | SINGLE TONE DECODER MODULE                           |
| TLN2443A | GUARD TONE DECODER MODULE                            |
| TLN2444A | F2 TONE DECODER MODULE (C2-R2 CONTROL)               |
| TLN2445A | SQUELCH CONTROL TONE DECODER MODULE                  |
| TLN2446A | REPEATER CONTROL TONE DECODER MODULE                 |
| TLN2447A | PRIVATE-LINE CONTROL TONE DECODER MODULE             |
| TLN2448A | "WILD CARD" TONE DECODER CONTROL MODULE              |
| TLN2449A | F2 TONE DECODER MODULE (PAGING CONTROL)              |
| TLN2450A | GUARD TONE DECODER MODULE (GUARD TONE RELAY CONTROL) |
| TLN2472B | BASIC CONTROL CHASSIS                                |
| TLN2473B | FULLY OPTIONABLE CONTROL CHASSIS (1-RCVR BASE)       |
| TLN2474B | FULLY OPTIONABLE CONTROL CHASSIS (2-RCVR BASE)       |
| TLN2475B | FULLY OPTIONABLE CONTROL CHASSIS (REPEATER RT)       |
| TLN2515B | FULLY OPTIONABLE CONTROL CHASSIS (4 FREQUENCY BASE)  |
| TPN1191A | STANDARD POWER SUPPLY                                |
| TPN1192A | BATTERY CHARGER POWER SUPPLY                         |

EPS-35239-A

KRB "B" SUFFIX MODELS (BASIC)  
 KSB "B" SUFFIX MODELS  
 (FULLY OPTIONABLE)  
 MODEL CHART  
 FOR  
**MSR 2000**  
 CONTINUOUS DUTY  
 BASE/REPEATER (RT) STATIONS  
 132-174MHZ 110 WATT RF POWER OUTPUT  
 LATER VERSION

CODE:  
 ● = ONE ITEM SUPPLIED  
 2 = INDICATES QUANTITY SUPPLIED  
 / = USED IN PLACE OF ONE 10.7MHZ I-F RECEIVER ON TWO RECEIVER STATIONS WITH CERTAIN FREQUENCY COMBINATIONS  
 \* = INDICATES A MODEL SERIES, SPECIFIC MODEL DEPENDS ON CARRIER FREQUENCY.

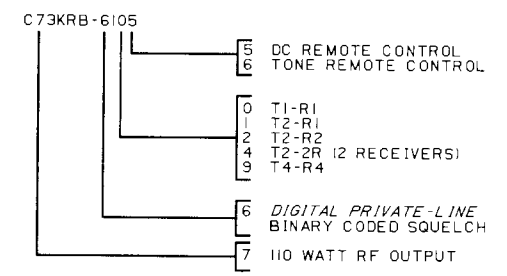

| STATION MODEL        | TYPE OF SQUELCH | CONTROL TYPE | TI = ONE XMIT FREQ.<br>T2 = TWO XMIT FREQS.<br>R1 = ONE RCVR. FREQ.<br>R2 = TWO RCVR. FREQS.<br>2R = TWO RCVR. - ONE FREQ. EACH |    | MODEL    | DESCRIPTION                                  |
|----------------------|-----------------|--------------|---|----|----------|--|
|                      |                 |              | TI  | R1 |          |  |
| <b>BASE STATIONS</b> |                 |              |   |    |          |  |
| C73KRB-1105B         | CARRIER         | T1-R1        | DC  | ●  | KLN6209A | VIBRASPONDER RESONANT REED                   |
| C73KRB-1106B         | CARRIER         | T1-R1        | DC  | ●  | KXN1086B | RECEIVE ELEMENT (10.7MHZ I-F) 5PPM           |
| C73KRB-1115B         | CARRIER         | T2-R1        | DC  | ●  | KXN1086A | RECEIVE ELEMENT (10.8MHZ I-F) 5PPM           |
| C73KRB-1116B         | CARRIER         | T2-R1        | DC  | ●  | KXN1088A | TRANSIT ELEMENT 5PPM                         |
| C73KRB-1125B         | CARRIER         | T2-R2        | DC  | ●  | TKN8319A | STATION INTERCONNECT CABLE                   |
| C73KRB-1126B         | CARRIER         | T2-R2        | DC  | ●  | TKN8288A | TWO-WIRE LINE CABLE                          |
| C73KRB-3105B         | PL              | T1-R1        | DC  | ●  | TKN8322A | PA POWER/EXCITER CABLE                       |
| C73KRB-3106B         | PL              | T1-R1        | DC  | ●  | TKN8323A | NON-DUPLEXER CABLES                          |
| C73KRB-3115B         | PL              | T2-R1        | DC  | ●  | TL02600A | 100 W CONTINUOUS DUTY PA                     |
| C73KRB-3116B         | PL              | T2-R1        | DC  | ●  | TL09230A | * TL09230A                                   |
| C73KRB-3125B         | PL              | T2-R2        | DC  | ●  | TLN2474B | DUPLEX EXCITER                               |
| C73KRB-3126B         | PL              | T2-R2        | DC  | ●  | TLN2443A | GUARD TONE DECODER MODULE                    |
| C73KRB-6105B         | DPL             | T1-R1        | DC  | ●  | TLN2444A | C2-R2 F2 TONE DECODER MODULE                 |
| C73KRB-6106B         | DPL             | T1-R1        | DC  | ●  | TLN2472B | BASIC CHASSIS                                |
| C73KRB-6115B         | DPL             | T2-R1        | DC  | ●  | TLN2475B | FULLY OPTIONABLE CHASSIS (2 REC)             |
| C73KRB-6116B         | DPL             | T2-R1        | DC  | ●  | TPN1191A | FULLY OPTIONABLE CHASSIS (REPEATER RT)       |
| C73KRB-6125B         | DPL             | T2-R2        | DC  | ●  | TR06290A | 120 V 60 HZ POWER SUPPLY                     |
| C73KRB-6126B         | DPL             | T2-R2        | DC  | ●  | TR06300A | RECEIVER 10.7MHZ NON-FILTERED                |
| C73KRB-1105B         | CARRIER         | T1-R1        | DC  | ●  | TR06310A | RECEIVER 10.8MHZ FILTERED                    |
| C73KRB-1106B         | CARRIER         | T1-R1        | DC  | ●  | TR06270A | 2 RECEIVER COUPLER                           |
| C73KRB-1115B         | CARRIER         | T2-R1        | DC  | ●  | TRN9688A | R1 AUDIO BOARD                               |
| C73KRB-1116B         | CARRIER         | T2-R1        | DC  | ●  | TRN9690A | R2 AUDIO BOARD                               |
| C73KRB-1125B         | CARRIER         | T2-R2        | DC  | ●  | TRN9691A | R2 AUDIO PL BOARD                            |
| C73KRB-1126B         | CARRIER         | T2-R2        | DC  | ●  | TRN9692A | R2 AUDIO DPL BOARD                           |
| C73KRB-3105B         | PL              | T1-R1        | DC  | ●  | TRN5073A | DUPLEX PL BOARD                              |
| C73KRB-3106B         | PL              | T1-R1        | DC  | ●  | TRN5074A | DUPLEX PL TA-RA BOARD                        |
| C73KRB-3115B         | PL              | T2-R1        | DC  | ●  | TRN5076A | DUPLEX DPL BOARD                             |
| C73KRB-3116B         | PL              | T2-R1        | DC  | ●  | TRN5077A | DUPLEX DPL TA-RA BOARD                       |
| C73KRB-3125B         | PL              | T2-R2        | DC  | ●  | TRN5571A | ANTENNA RELAY                                |
| C73KRB-3126B         | PL              | T2-R2        | DC  | ●  | TRN5237A | 1 RECEIVER, 2-WIRE AUDIO: LINE DRIVER MODULE |
| C73KRB-6105B         | DPL             | T1-R1        | DC  | ●  | TRN5240A | 2 RECEIVER, 2-WIRE AUDIO: LINE DRIVER MODULE |
| C73KRB-6106B         | DPL             | T1-R1        | DC  | ●  | TRN5254A | F1 PL CONTROL MODULE                         |
| C73KRB-6115B         | DPL             | T2-R1        | DC  | ●  | TRN5254A | F1 CARRIER SQUELCH CONTROL MODULE            |
| C73KRB-6116B         | DPL             | T2-R1        | DC  | ●  | TRN5255A | F1 PL CONTROL MODULE                         |
| C73KRB-6125B         | DPL             | T2-R2        | DC  | ●  | TRN5256A | F2-R2 CONTROL MODULE                         |
| C73KRB-6126B         | DPL             | T2-R2        | DC  | ●  | TRN5296A | CMOS TIME-OUT TIMER                          |
| C73KRB-1105B         | CARRIER         | T1-R1        | DC  | ●  | TRN5322A | 4-FREQUENCY CONTROL MODULE                   |
| C73KRB-1106B         | CARRIER         | T1-R1        | DC  | ●  | TRN5320A | F1 PL TONE DECODER MODULE                    |
| C73KRB-1115B         | CARRIER         | T2-R1        | DC  | ●  | TRN5321A | F1 PL TONE DECODER MODULE                    |
| C73KRB-1116B         | CARRIER         | T2-R1        | DC  | ●  | TRN5322A | STATION CONTROL MODULE                       |
| C73KRB-1125B         | CARRIER         | T2-R2        | DC  | ●  | TRN5324A | F1 TONE DECODER MODULE                       |
| C73KRB-1126B         | CARRIER         | T2-R2        | DC  | ●  | TRN5325A | SQUELCH GATE MODULE                          |
| C73KRB-3105B         | PL              | T1-R1        | DC  | ●  | TRN5327A | F2 TONE DECODER MODULE                       |
| C73KRB-3106B         | PL              | T1-R1        | DC  | ●  | TRN5328A | 4F F1 PL TONE DECODER MODULE                 |
| C73KRB-3115B         | PL              | T2-R1        | DC  | ●  | TRN5350A | 4F F1 PL TONE DECODER MODULE                 |
| C73KRB-3116B         | PL              | T2-R1        | DC  | ●  | TRN5351A | SIMPLEX JUNCTION BOX                         |
| C73KRB-3125B         | PL              | T2-R2        | DC  | ●  | TRN5352A | DUPLEX JUNCTION BOX                          |
| C73KRB-3126B         | PL              | T2-R2        | DC  | ●  | TRN5353A | RF PLASTIC PLUG                              |
| C73KRB-6105B         | DPL             | T1-R1        | DC  | ●  | TRN5354A | D-TYPE CONNECTOR PLASTIC PLUG                |
| C73KRB-6106B         | DPL             | T1-R1        | DC  | ●  | TRN5355A | BATTERY PLASTIC PLUG                         |
| C73KRB-6115B         | DPL             | T2-R1        | DC  | ●  | TRN5567A | 32" CABINET HARDWARE                         |
| C73KRB-6116B         | DPL             | T2-R1        | DC  | ●  | TRN5569A | 32" CABINET SHELL                            |
| C73KRB-6125B         | DPL             | T2-R2        | DC  | ●  | TRN5427A | 110 V POWER CORD                             |
| C73KRB-6126B         | DPL             | T2-R2        | DC  | ●  | TRN5575A | PS COVER                                     |
| C73KRB-1105B         | CARRIER         | T1-R1        | DC  | ●  | TRN5429A | BASIC COVERS                                 |
| C73KRB-1106B         | CARRIER         | T1-R1        | DC  | ●  | TRN5430A | OPTIONAL COVERS                              |
| C73KRB-1115B         | CARRIER         | T2-R1        | DC  | ●  | TRN5431A | REPEATER COVERS                              |
| C73KRB-1116B         | CARRIER         | T2-R1        | DC  | ●  | TRN5443A | DUPLEX RF COVER                              |
| C73KRB-1125B         | CARRIER         | T2-R2        | DC  | ●  | TRN6005A | DPL CODE PLUG                                |
| C73KRB-1126B         | CARRIER         | T2-R2        | DC  | ●  | TRN9415A | HARDWARE OPT CONTROL R2                      |
| C73KRB-3105B         | PL              | T1-R1        | DC  | ●  |          |  |
| C73KRB-3106B         | PL              | T1-R1        | DC  | ●  |          |  |
| C73KRB-3115B         | PL              | T2-R1        | DC  | ●  |          |  |
| C73KRB-3116B         | PL              | T2-R1        | DC  | ●  |          |  |
| C73KRB-3125B         | PL              | T2-R2        | DC  | ●  |          |  |
| C73KRB-3126B         | PL              | T2-R2        | DC  | ●  |          |  |
| C73KRB-6105B         | DPL             | T1-R1        | DC  | ●  |          |  |
| C73KRB-6106B         | DPL             | T1-R1        | DC  | ●  |          |  |
| C73KRB-6115B         | DPL             | T2-R1        | DC  | ●  |          |  |
| C73KRB-6116B         | DPL             | T2-R1        | DC  | ●  |          |  |
| C73KRB-6125B         | DPL             | T2-R2        | DC  | ●  |          |  |
| C73KRB-6126B         | DPL             | T2-R2        | DC  | ●  |          |  |
| C73KRB-1105B         | CARRIER         | T1-R1        | DC  | ●  |          |  |
| C73KRB-1106B         | CARRIER         | T1-R1        | DC  | ●  |          |  |
| C73KRB-1115B         | CARRIER         | T2-R1        | DC  | ●  |          |  |
| C73KRB-1116B         | CARRIER         | T2-R1        | DC  | ●  |          |  |
| C73KRB-1125B         | CARRIER         | T2-R2        | DC  | ●  |          |  |
| C73KRB-1126B         | CARRIER         | T2-R2        | DC  | ●  |          |  |
| C73KRB-3105B         | PL              | T1-R1        | DC  | ●  |          |  |
| C73KRB-3106B         | PL              | T1-R1        | DC  | ●  |          |  |
| C73KRB-3115B         | PL              | T2-R1        | DC  | ●  |          |  |
| C73KRB-3116B         | PL              | T2-R1        | DC  | ●  |          |  |
| C73KRB-3125B         | PL              | T2-R2        | DC  | ●  |          |  |
| C73KRB-3126B         | PL              | T2-R2        | DC  | ●  |          |  |
| C73KRB-6105B         | DPL             | T1-R1        | DC  | ●  |          |  |
| C73KRB-6106B         | DPL             | T1-R1        | DC  | ●  |          |  |
| C73KRB-6115B         | DPL             | T2-R1        | DC  | ●  |          |  |
| C73KRB-6116B         | DPL             | T2-R1        | DC  | ●  |          |  |
| C73KRB-6125B         | DPL             | T2-R2        | DC  | ●  |          |  |
| C73KRB-6126B         | DPL             | T2-R2        | DC  | ●  |          |  |
| C73KRB-1105BT        | CARRIER         | T1-R1        | DC  | ●  |          |  |
| C73KRB-1106BT        | CARRIER         | T1-R1        | DC  | ●  |          |  |
| C73KRB-3105BT        | PL              | T1-R1        | DC  | ●  |          |  |
| C73KRB-3106BT        | PL              | T1-R1        | DC  | ●  |          |  |
| C73KRB-6105BT        | DPL             | T1-R1        | DC  | ●  |          |  |
| C73KRB-6106BT        | DPL             | T1-R1        | DC  | ●  |          |  |





**MSR 2000 VHF INTERMITTENT DUTY STATIONS OPTION CHART**

| <b>Option</b> | <b>Add</b>                       | <b>Delete</b>                                | <b>Description</b>   |
|---------------|----------------------------------|--|--|
| C11AB         | TRN5295A                         | —  | Time-Out Timer   |
| C12AG         | HLD4052A                         | —  | Receiver Preamplifier  |
| C13AA         | TLN2445A                         | —  | Remote Squelch Control   |
| C14AF         | TLN2447A                         | —  | Receive PL Tone On/Off   |
| C15AA         | TLN2448A                         | —  | “Wild Card” Option   |
| C28AN         | TPN1192A<br>TKN8295A<br>TRN5155A | TPN1191A<br>TRN5355A<br>—                    | Battery Revert   |
| C28AU         | TKN8295A<br>TPN1226A<br>TRN5155A | TPN1222A<br>TRN5355A<br>—                    | Battery Revert   |
| C28AV         | TPN1227A<br>TKN8295A<br>TRN5155A | TPN1223A<br>TRN5355A<br>—                    | Battery Revert   |
| C31DU         | —                                | TRD6172A                                     | Omit Receiver (146-174 MHz)                                    |
| C31EK         | —                                | TRD6292A                                     | Omit Receiver (146-174 MHz)                                    |
| C50AC         | —                                | —  | Decreased RF Power Output for Maritime Operation (146-174 MHz) |
| C56AC         | TRN5326A                         | TRN5325A                                     | Tone Mute Second Receiver (F2-R2)                              |
| C63AK         | TRN5239A                         | TRN5240A                                     | DC Transmit PL On/Off  |
| C63AL         | TLN2449A                         | —  | Tone Transmit PL On/Off  |
| C71AB         | —                                | TMN6054A                                     | Omit Microphone  |
| C75AB         | —                                | TRN5295A                                     | Omit Time-Out Timer  |
| C83AC         | —<br>—<br>—                      | TLN2443A<br>TRN5322A<br>TRN5236A<br>TKN8286A | Omit Wire Line Control (Carrier Squelch, Tone Stations)        |
| C84AC         | —<br>—<br>—                      | TLN2443A<br>TRN5320A<br>TRN5236A<br>TKN8286A | Omit Wire Line Control (PL/DPL, Tone Stations)                 |
| C85AB         | —<br>—<br>—                      | TRN5254A<br>TRN5236A<br>TKN8286A             | Omit Wire Line Control (Carrier Squelch, DC Stations)          |
| C86AC         | —<br>—<br>—                      | TRN5240A<br>TRN5236A<br>TKN8286A             | Omit Wire Line Control (PL/DPL, DC Stations)                   |
| C92AA         | TRN9086A<br>TBN6386A<br>TRN5426A | TRN9085A<br>TBN6385A<br>TRN5425A             | 29” Cabinet  |
| C113AA        | TMN6054A                         | —  | Dynamic Microphone   |
| C116BP        | TRD6182A<br>TRN5431A<br>TRN5443A | TRN6172A<br>TRN5430A<br>—                    | Shield Kit (One Receiver)                                      |
| C116BQ        | TRN5474A<br>TRN5443A<br>TRD6182A | TRN5429A<br>TRD6172A<br>—                    | Shield Kit (Basic)   |
| C116CB        | TRD6302A<br>TRN5431A<br>TRN5443A | TRN6292A<br>TRN5430A<br>—                    | Shield Kit (One Receiver)                                      |
| C116CC        | TRN5474A<br>TRN5443A<br>TRD6302A | TRN5429A<br>TRD6292A<br>—                    | Shield Kit (Basic)   |
| C140AD        | —                                | —  | “AND” Squelch  |
| C143AD        | TRN5257A                         | TRN5254A                                     | Repeater Control (Carrier Squelch, DC Stations)                |
| C143AE        | TRN5257A                         | TRN5240A                                     | Repeater Control (PL/DPL, DC Stations)                         |
| C143AF        | TLN2446A                         | —  | Repeater Control (Tone Stations)                               |

**MSR 2000 VHF INTERMITTENT DUTY STATIONS OPTION CHART (Cont'd.)**

| Option | Add  | Delete   | Description                            |
|--------|--|--|--|
| C144AH | TRN5235A<br>TKN8287A   | TRN5236A<br>TKN8286A                                   | 4-Wire Line Audio (One Receiver)       |
| C144AJ | TRN5235A<br>TKN8287A   | TRN5237A<br>TKN8286A                                   | 4-Wire Line Audio (Two Receivers)      |
| C149CV | TRN9689A<br>TMN6054A<br>TRN5080A                                     | TRN9688A<br>—<br>—                                     | Intercom, Metering and Microphone      |
| C149DA | TRN9689A<br>TMN6054A<br>TRN5080A                                     | TRN9688A<br>TRN5353A<br>—                              | Intercom, Metering and Microphone      |
| C150AH | TRN5324A<br>TKN8281A   | TRN5254A<br>TRN5353A                                   | RA Base (Carrier Squelch, DC Stations) |
| C150AJ | TRN5324A<br>TKN8281A   | TRN5240A<br>TRN5353A                                   | RA Base (PL/DPL, DC Stations)          |
| C150AK | TRN5324A<br>TKN8281A   | —<br>—   | RA Base (Tone Station)                 |
| C158AB | TRN5292A<br>TRN5330A<br>(4)KLN6210A                                  | —<br>—<br>KLN6209A                                     | Multi PL Encoder (Rptr)                |
| C158AE | TRN5292A<br>TRN5330A<br>(4)KLN6210A                                  | —<br>—<br>KLN6209A                                     | Multi PL Encoder (Base)                |
| C181AG | TBN6386A<br>TKN8475A<br>TLD2622A<br>TRN5352A<br>TRN5426A<br>TRN9086A | TBN6385A<br>TKN8289A<br>—<br>—<br>TRN5425A<br>TRN9085A | Add 2 Can Duplexer (148-174 MHz)       |
| C182AH | TRN9086A<br>TBN6386A<br>TRN5426A<br>TKN8290A<br>TLD2502A<br>TRN5352A | TRN9085A<br>TBN6385A<br>TRN5425A<br>TKN8289A<br>—<br>— | Add Duplexer (148-174 MHz)             |
| C226AH | TRN5069A<br>TRN5079A   | TRN5068A<br>—  | Intercom Only                          |
| C226AL | TRN9689A<br>TRN5079A   | TRN9688A<br>—  | Intercom Only                          |
| C257AD | TPN1222A<br>TRN9109A<br>TRN9114A<br>TRN9209A                         | TPN1191A<br>TRN5442A<br>TRN5350A<br>—                  | Multi-Voltage, 50 Hz, Basic            |
| C257AE | TPN1222A<br>TRN9109A<br>TRN9113A<br>TRN9209A                         | TPN1191A<br>TRN5442A<br>TRN5351A<br>—                  | Multi-Voltage, 50 Hz, Fully Optionable |
| C261AC | (4)TLN8381A<br>TRN5329A  | —<br>—   | Multi PL Decoder                       |
| C261AH | (4)TLN8381A<br>TRN6329A  | KLN6209A   | Multi PL Decoder Rptr                  |
| C262AE | TRN5292A<br>TRN5329A<br>(4)KLN6210A<br>(4)TLN8381A                   | (2)KLN6209A<br>—<br>—<br>—                             | Multi PL Repeater                      |
| C263AB | TRN5329A<br>TRN5292A<br>TRN5330A<br>(4)KLN6210A<br>(4)TLN8381A       | KLN6209A<br>—<br>—<br>—<br>—                           | Multi PL Encoder/Decoder               |

**MSR 2000 VHF INTERMITTENT DUTY STATIONS OPTION CHART (Cont'd.)**

| <b>Option</b> | <b>Add</b>                                   | <b>Delete</b>                         | <b>Description</b>                     |
|---------------|--|---------------------------------------|--|
| C266AA        | —  | KLN6210A                              | Omit One Vibrasender Reed              |
| C267AA        | —  | TLN8381A                              | Omit One Vibrasponder Reed             |
| C269AP        | TRN5293A<br>TRN5294A<br>TKN8287A             | TRN5236A<br>TKN8286A<br>—             | <i>Spectra-TAC</i> Operation (Base)    |
| C269AQ        | TRN5293A<br>TRN5294A<br>TKN8287A<br>TRN5331A | TLN5236A<br>TKN8286A<br>TRN5324A<br>— | <i>Spectra-TAC</i> Operation (Rptr)    |
| C276AA        | TRN5075A<br>KLN6209A                         | TRN5074A<br>—                         | Simplex PL TA-RB                       |
| C276AB        | TRN5078A<br>TRN6005A                         | TRN5077A<br>—                         | Simplex DPL TA-RB                      |
| C323AA        | —  | TRN5427A                              | Omit Power Cord                        |
| C501AJ        | —  | KXN1088A                              | Omit One Transmit Element              |
| C502AH        | —  | (2)KXN1088A                           | Omit Two Transmit Elements             |
| C503AE        | —  | (3)KXN1088A                           | Omit Three Transmit Elements           |
| C504AE        | —  | (4)KXN1088A                           | Omit Four Transmit Elements            |
| C521AR        | —  | KXN1086B                              | Omit One Receive Element               |
| C522AM        | —  | (2)KXN1086B                           | Omit Two Receive Elements              |
| C523AH        | —  | (3)KXN1086B                           | Omit Three Receive Elements            |
| C524AJ        | —  | (4)KXN1086B                           | Omit Four Receive Elements             |
| C576AA        | TLN2442A                                     | —                                     | Single-Tone Decoder                    |
| C601AC        | KXN1095A                                     | KXN1088A                              | One 2PPM Transmit Element              |
| C602AB        | (2)KXN1095A                                  | (2)KXN1088A                           | Two 2PPM Transmit Elements             |
| C603AB        | (3)KXN1095A                                  | (3)KXN1088A                           | Three 2PPM Transmit Elements           |
| C604AC        | (4)KXN1095A                                  | (4)KXN1088A                           | Four 2PPM Transmit Elements            |
| C621AC        | KXN1112AA                                    | KXN1086B                              | One 2PPM Receive Element               |
| C622AB        | (2)KXN1112AA                                 | (2)KXN1086B                           | Two 2PPM Receive Elements              |
| C623AB        | (3)KXN1112AA                                 | (3)KXN1086B                           | Three 2PPM Receive Elements            |
| C624AB        | (4)KXN1112AA                                 | (4)KXN1086B                           | Four 2PPM Receive Elements             |
| C681AB        | TPN1223A<br>TRN9114A<br>TRN9110A<br>TRN9210A | TPN1191A<br>TRN5350A<br>TRN5442A<br>— | Multi-Voltage, 60 Hz, Basic            |
| C681AC        | TPN1223A<br>TRN9110A<br>TRN9113A<br>TRN9210A | TPN1191A<br>TRN5442A<br>TRN5351A<br>— | Multi-Voltage, 60 Hz, Fully Optionable |
| C691AA        | TRN5972A                                     | TRN5427A                              | European Power Cord                    |
| C692AA        | TRN5971A                                     | TRN5427A                              | United Kingdom Power Cord              |

## CONTINUOUS DUTY STATION PERFORMANCE SPECIFICATIONS

### GENERAL

| Model              | Frequency (MHz) | Minimum RF Output Power   | Maximum PA Final Input Power | Input Voltage                         | A.C. Input Current |      |                            |      |
|--------------------|-----------------|---|------------------------------|---------------------------------------|--------------------|------|----------------------------|------|
|                    |                 |   |                              |                                       | Standard Supply    |      | Battery Charging*** Supply |      |
|                    |                 |   |                              |                                       | Stby               | Xmit | Stby                       | Xmit |
| C73KRB<br>C73KSB*  | 136-174         | 100 W**   | 200 W                        | 120 V ac +10%<br>-20%; 60 Hz Standard | 1A                 | 4.6A | 1.5-2A                     | 4.6A |
| No. of Frequencies |                 | Single and two-frequency stations (dc and tone remote)<br>Four-frequency stations (tone remote)   |                              |                                       |                    |      |                            |      |
| Squelch Options    |                 | Carrier squelch, <i>Private-Line</i> coded squelch, and <i>Digital Private-Line</i> coded squelch |                              |                                       |                    |      |                            |      |
| Metering           |                 | Optional internal-mounted meter used to measure all essential circuits for tuning and checking.   |                              |                                       |                    |      |                            |      |

\*Fully Optionable Models

\*\*Variable Down to 60 W

\*\*\*Does Not Include Battery Charging Current

### TRANSMITTER 136-174 MHz

|                                |  |
|--------------------------------|--|
| RF Output Power                | 110/50 watts intermittent duty (cont. variable)  |
| Output Impedance               | 50 ohms  |
| Oscillator Frequency Stability | Channel element maintains oscillator frequency within $\pm .0005\%$ ( $\pm .0002\%$ optional) from $-30^{\circ}\text{C}$ to $+60^{\circ}\text{C}$ ambient ( $+25^{\circ}\text{C}$ reference) |
| Transmitter Sideband Noise     | -90 dB @ $\pm 30$ kHz<br>-105 dB @ $\pm 1$ MHz   |
| Spurious & Harmonics           | More than 85 dB below carrier  |
| Modulation                     | 15F2 and 16F3: $\pm 5$ kHz for 100% at 1000 Hz.  |
| Audio Sensitivity              | Remote telephone line: -20 dBm max. for 60% max. dev. at 1000 Hz.  |
| FM Noise                       | 55 dB below 60% system dev. at 1000 Hz   |
| Audio Response                 | +1, -3 dB from 6 dB/octave pre-emphasis, 300-3000 Hz, referenced to 1000 Hz  |
| Audio Distortion               | Less than 2% at 1000 Hz; 60% system dev.   |
| FCC Designation                | ABZ89FC3640 ( $\pm .0005\%$ stability)<br>ABZ89FC3641C ( $\pm .0002\%$ stability)<br>Licensable under parts 22, 74, 81, and 90 of FCC Rules.   |

### RECEIVER 132-174 MHz

|  |   |  |
|--|---|--|
| Channel Spacing  | 30 kHz/25 kHz   |  |
| EIA Modulation Acceptance                                    | $\pm 7$ kHz minimum   |  |
| Oscillator Frequency Stability                               | Channel element maintains oscillator frequency within $\pm .0005\%$ ( $\pm .0002\%$ optional) from $-30^{\circ}\text{C}$ to $+60^{\circ}\text{C}$ ambient ( $+25^{\circ}\text{C}$ reference)  |  |
| Sensitivity<br>20 dB Quieting<br>EIA SINAD                   | <b>Without Preamp</b><br>Less than 0.5 uV<br>Less than 0.35 uV  | <b>With Preamp</b><br>Less than 0.25 uV<br>Less than 0.20 uV |
| Intermodulation — EIA SINAD                                  | -85 dB  | -80 dB   |
| Selectivity — EIA SINAD                                      | -100 dB (-95 dB with preamp)  |  |
| Spurious & Image Rejection                                   | 100 dB minimum  | 100 dB minimum   |
| Squelch Sensitivity<br>Carrier Squelch<br>Tone-Coded Squelch | 0.2 uV or less at threshold<br>0.2 uV or less   | 0.10 uV or less at threshold<br>0.10 uV or less              |
| Audio Characteristics<br>Remote Control Models               | <b>Telephone Line:</b><br>Output: +11 dBm @600 ohms<br>Response: +1, -3 dB<br>Distortion: 3% @1000 Hz<br>Hum & Noise: -55 dB<br><b>For local service audio:</b><br>Output Available: 1 W @8 ohms<br>Response: +2, -8 dB<br>Distortion: 5% @1000 Hz<br>Hum & Noise: -55 dB |  |
| FCC Receiver Certification Number                            | ABZ89FR3633   |  |

Meets EIA Specifications per RS152B, RS204B, and RS220A.

SPECIFICATIONS SUBJECT TO CHANGE WITHOUT NOTICE

**MSR 2000 VHF CONTINUOUS DUTY STATIONS OPTION CHART**

| <b>Option</b> | <b>Add</b>                       | <b>Delete</b>                                | <b>Description</b>   |
|---------------|----------------------------------|--|--|
| C11AB         | TRN5295A                         | —  | Time-Out Timer   |
| C12AG         | HLD4052A                         | —  | Receiver Preamplifier (146-174 MHz)                            |
| C12AH         | HLD4051A                         | —  | Receiver Preamplifier (132-150.8 MHz)                          |
| C13AA         | TLN2445A                         | —  | Remote Squelch Control   |
| C14AF         | TLN2447A                         | —  | Receive PL Tone On/Off   |
| C15AA         | TLN2448A                         | —  | “Wild Card” Option   |
| C28AN         | TPN1192A<br>TKN8295A<br>TRN5155A | TPN1191A<br>TRN5355A<br>—                    | Battery Revert   |
| C28AU         | TPN1226A<br>TKN8295A<br>TRN5155A | TPN1222A<br>TRN5355A                         | Battery Revert   |
| C28AV         | TPN1227A<br>TKN8295A<br>TRN5155A | TPN1223A<br>TRN5355A                         | Battery Revert   |
| C31DY         | —<br>—                           | TRD6171A<br>TRD6172A                         | Omit Receiver (132-150.8 MHz)<br>Omit Receiver (146-174 MHz)   |
| C31EL         | —<br>—                           | TRD6291A<br>TRD6292A                         | Omit Receiver (132-150.8 MHz)<br>Omit Receiver (146-174 MHz)   |
| C50AC         | —                                | —  | Decreased RF Power Output for Maritime Operation (132-174 MHz) |
| C52AA         | TRN5568A<br>TRN5570A             | TRN5567A<br>TRN5569A                         | 37” Cabinet  |
| C56AC         | TRN5326A                         | TRN5325A                                     | Tone Mute Second Receiver (F2-R2)                              |
| C63AK         | TRN5239A                         | TRN5240A                                     | DC Transmit PL On/Off  |
| C63AL         | TLN2449A                         | —  | Tone Transmit PL On/Off  |
| C71AB         | —                                | TMN6054A                                     | Omit Microphone  |
| C75AB         | —                                | TRN5295A                                     | Omit Time-Out Timer  |
| C83AC         | —<br>—<br>—<br>—                 | TLN2443A<br>TRN5322A<br>TRN5236A<br>TKN8286A | Omit Wire Line Control (Carrier Squelch, Tone Stations)        |
| C84AC         | —<br>—<br>—<br>—                 | TLN2443A<br>TRN5320A<br>TRN5236A<br>TKN8286A | Omit Wire Line Control (PL/DPL, Tone Stations)                 |
| C85AB         | —<br>—<br>—                      | TRN5254A<br>TRN5236A<br>TKN8286A             | Omit Wire Line Control (Carrier Squelch, DC Stations)          |
| C86AC         | —<br>—<br>—                      | TRN5240A<br>TRN5236A<br>TKN8286A             | Omit Wire Line Control (PL/DPL, DC Stations)                   |
| C113AA        | TMN6054A                         | —  | Dynamic Microphone   |
| C116BP        | TRD6182A<br>TRN5431A<br>TRN5443A | TRN6172A<br>TRN5430A<br>—                    | Shield Kit (One Receiver)                                      |
| C116BQ        | TRN5474A<br>TRN5443A<br>TRD6182A | TRN5429A<br>TRD6172A<br>—                    | Shield Kit (Basic)   |
| C116BT        | TRD6181A<br>TRN5431A<br>TRN5443A | TRD6171A<br>TRN5430A<br>—                    | Shield Kit (146-174 MHz)                                       |
| C116BU        | TRD6181A<br>TRN5443A<br>TRN5474A | TRD6171A<br>TRN5429A<br>—                    | Shield Kit (132-150.8 MHz)                                     |
| C116CB        | TRD6302A<br>TRN5431A<br>TRN5443A | TRN6292A<br>TRN5430A<br>—                    | Shield Kit (One Receiver)                                      |
| C116CC        | TRN5474A<br>TRN5443A<br>TRD6302A | TRN5429A<br>TRD6292A                         | Shield Kit (Basic)   |

**MSR 2000 VHF CONTINUOUS DUTY STATIONS OPTION CHART (Cont'd.)**

| Option | Add  | Delete   | Description  |
|--------|--|--|--|
| C116CD | TRD6301A<br>TRN5431A<br>TRN5443A                                     | TRD6291A<br>TRN5430A<br>—                              | Shield Kit (146-174 MHz)                                   |
| C116CE | TRD6301A<br>TRN5443A<br>TRN5474A                                     | TRD6291A<br>TRN5429A<br>—                              | Shield Kit (132-150.8 MHz)                                 |
| C140AD | —  | —  | "AND" Squelch  |
| C143AD | TRN5257A   | TRN5254A   | Repeater Control (Carrier Squelch, DC Stations)            |
| C143AE | TRN5257A   | TRN5240A   | Repeater Control (PL/DPL, DC Stations)                     |
| C143AF | TLN2446A   | —  | Repeater Control (Tone Stations)                           |
| C144AH | TRN5235A<br>TKN8287A   | TRN5236A<br>TKN8286A                                   | 4-Wire Line Audio (One Receiver)<br>w/o EIA Rack Mounting  |
| C144AJ | TRN5235A<br>TKN8287A   | TRN5237A<br>TKN8286A                                   | 4-Wire Line Audio (Two Receivers)<br>w/o EIA Rack Mounting |
| C149CV | TRN9689A<br>TMN6054A<br>TRN5080A                                     | TRN9688A<br>—<br>—                                     | Intercom, Metering and Microphone                          |
| C149DA | TRN9689A<br>TMN6054A<br>TRN5080A                                     | TRN9688A   | Intercom, Metering and Microphone                          |
| C150AH | TRN5324A<br>TKN8281A   | TRN5254A<br>TRN5353A                                   | RA Base (Carrier Squelch, DC Stations)                     |
| C150AJ | TRN5324A<br>TKN8281A   | TRN5240A<br>TRN5353A                                   | RA Base (PL/DPL, DC Stations)                              |
| C150AK | TRN5324A<br>TKN8281A   | —<br>TRN5353A  | RA Base (Tone Station)                                     |
| C158AB | TRN5292A<br>TRN5330A<br>(4)KLN6210A                                  | —<br>—<br>KLN6209A                                     | Multi PL Encoder (Rptr)                                    |
| C158AE | TRN5292A<br>TRN5330A<br>(4)KLN6210A                                  | —<br>—<br>KLN6209A                                     | Multi PL Encoder (Base)                                    |
| C164   | —  | —  | EIA Rack Mounting (see Instruction Manual 68P81112E95)     |
| C181AH | TBN6394A<br>TKN8324A<br>TLD2622A<br>TRN5352A<br>TRN5568A<br>TRN5570A | TBN6393A<br>TKN8323A<br>—<br>—<br>TRN5567A<br>TRN5569A | Add 2 Can Duplexer (148-174 MHz)                           |
| C182AJ | TKN8324A<br>TLD2502A<br>TRN5352A<br>TRN5568A<br>TRN5570A             | TRN8323A<br>—<br>—<br>TRN5567A<br>TRN5569A             | Add Duplexer (148-174 MHz)                                 |
| C226AH | TRN5069A<br>TRN5079A   | TRN5068A<br>—  | Intercom Only  |
| C226AL | TRN9689A<br>TRN5079A   | TRN9689A<br>—  | Intercom Only  |
| C257AD | TPN1222A<br>TRN9109A<br>TRN9114A<br>TRN9209A                         | TPN1191A<br>TRN5442A<br>TRN5350A<br>—                  | Multi-Voltage, 50 Hz, Basic                                |
| C257AE | TPN1222A<br>TRN9109A<br>TRN9113A<br>TRN9209A                         | TPN1191A<br>TRN5442A<br>TRN5351A<br>—                  | Multi-Voltage, 50 Hz, Fully Optionable                     |
| C261AC | (4)TLN8381A<br>TRN5329A  | —<br>—   | Multi PL Decoder   |
| C261AH | (4)TLN8381A<br>TRN5329A  | KLN6209A<br>—  | Multi PL Decoder RPTR                                      |

**MSR 2000 VHF CONTINUOUS DUTY STATIONS OPTION CHART (Cont'd.)**

| <b>Option</b> | <b>Add</b>   | <b>Delete</b>                         | <b>Description</b>                     |
|---------------|--|---------------------------------------|--|
| C262AE        | TRN5292A<br>TRN5329A<br>(4)KLN6210A<br>(4)TLN8381A             | (2)KLN6209A<br>—<br>—<br>—            | Multi PL Repeater                      |
| C263AB        | TRN5329A<br>TRN5292A<br>TRN5330A<br>(4)KLN6210A<br>(4)TLN8381A | KLN6209A<br>—<br>—<br>—<br>—          | Multi PL Encoder/Decoder               |
| C266AA        | —  | KLN6210A                              | Omit One Vibrasender Reed              |
| C267AA        | —  | TLN8381A                              | Omit One Vibrasponder Reed             |
| C269AP        | TRN5293A<br>TRN5294A<br>TKN8287A                               | TRN5236A<br>TKN8286A<br>—             | <i>Spectra-TAC</i> Operation (Basic)   |
| C269AQ        | TRN5293A<br>TRN5294A<br>TKN8287A<br>TRN5331A                   | TLN5236A<br>TKN8286A<br>TRN5324A<br>— | <i>Spectra-TAC</i> Operation (Rptr)    |
| C276AA        | TRN5075A<br>KLN6209A   | TRN5074A<br>—                         | Simplex PL TA-RB                       |
| C276AB        | TRN5078A<br>TRN6005A   | TRN5077A<br>—                         | Simplex DPL TA-RB                      |
| C323AA        | —  | TRN5427A                              | Omit Power Cord                        |
| C501AJ        | —  | KXN1088A                              | Omit One Transmit Element              |
| C502AH        | —  | (2)KXN1088A                           | Omit Two Transmit Elements             |
| C503AE        | —  | (3)KXN1088A                           | Omit Three Transmit Elements           |
| C504AE        | —  | (4)KXN1088A                           | Omit Four Transmit Elements            |
| C521AR        | —  | KXN1086B                              | Omit One Receive Element               |
| C522AM        | —  | (2)KXN1086B                           | Omit Two Receive Elements              |
| C523AH        | —  | (3)KXN1086B                           | Omit Three Receive Elements            |
| C524AJ        | —  | (4)KXN1086B                           | Omit Four Receive Elements             |
| C576AA        | TLN2442A   | —                                     | Single-Tone Decoder                    |
| C601AE        | KXN1095A   | KXN1088A                              | One 2PPM Transmit Element              |
| C602AC        | (2)KXN1095A  | (2)KXN1088A                           | Two 2PPM Transmit Elements             |
| C603AC        | (3)KXN1095A  | (3)KXN1088A                           | Three 2PPM Transmit Elements           |
| C604AD        | (4)KXN1095A  | (4)KXN1088A                           | Four 2PPM Transmit Elements            |
| C621AC        | KXN1112AA  | KXN1086B                              | One 2PPM Receive Element               |
| C622AB        | (2)KXN1112AA   | (2)KXN1086B                           | Two 2PPM Receive Elements              |
| C623AB        | (3)KXN1112AA   | (3)KXN1086B                           | Three 2PPM Receive Elements            |
| C624AB        | (4)KXN1112AA   | (4)KXN1086B                           | Four 2PPM Receive Elements             |
| C681AB        | TPN1223A<br>TRN9114A<br>TRN9110A<br>TRN9210A                   | TPN1191A<br>TRN5350A<br>TRN5442A<br>— | Multi-Voltage, 60 Hz, Basic            |
| C681AC        | TPN1223A<br>TRN9110A<br>TRN9210A<br>TRN9113A                   | TRN1191A<br>TRN5442A<br>TRN5351A<br>— | Multi-Voltage, 60 Hz, Fully Optionable |
| C691AA        | TRN5972A   | TRN5427A                              | European Power Cord                    |
| C692AA        | TRN5971A   | TRN5427A                              | United Kingdom Power Cord              |

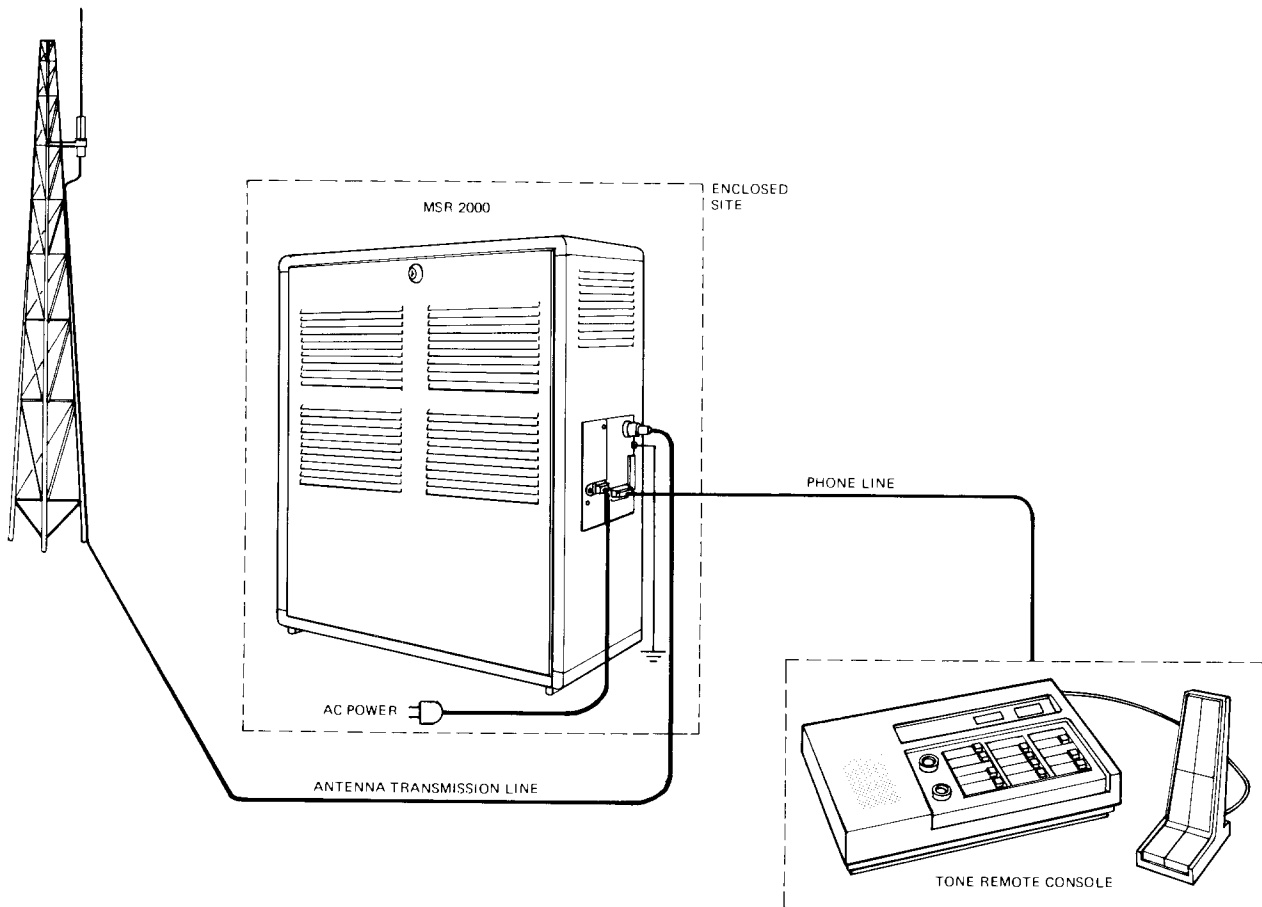

GBEPS-34846-0

Figure 1. Typical System Configuration

**1. MANUAL USAGE**

This manual describes all aspects of the *MSR 2000* radio station with the exception of remote control and station applications. Separate Control and Audio manual 68P81061E40 describes how these stations are remotely controlled and outlines the various types of base and repeater stations and their applications.

**2. INTRODUCTION**

The Motorola *MSR 2000* is a free standing, all solid state base station radio. It is dc or tone remote controllable and is available in either a basic or optional version.

The basic version of the *MSR 2000* station provides the same quality and performance specifications as the

DESCRIPTION

*technical writing services*

1301 E. Algonquin Road, Schaumburg, Il. 60196



optionable version. The basic version is intended for those systems that require little change or expansion in the future. See Figure 2.

The optionable version of the *MSR 2000* station satisfies more complex applications requirements. It also has more capacity for future expansion. It has capabilities for tone control of T4R4 channels, repeater application, and two receivers. See Figure 3.

The *MSR 2000* VHF High Band station is available in either continuous or intermittent duty models. Basic or fully optionable models are available for either duty cycle.

### 3. STATION COMPONENT DESCRIPTION

(Refer to Figure 4.)

#### 3.1 TRANSMITTER

The transmitter generates a frequency modulated rf carrier signal that is delivered to the antenna output connector, part of the station junction box. The transmitter consists of the following items:

- Channel Element — An unheated, temperature-compensated crystal oscillator plug-in module (channel element) provides a stable fundamental rf frequency for the transmitter. One channel element is used for each transmitter frequency.
- Exciter — The exciter provides the low power excitation signal for the power amplifier. An "IDC" (Instantaneous Deviation Control) circuit amplifies

and limits audio signals from the control line to prevent over deviation. Amplified audio is applied to the channel element to produce direct FM modulation. Multipliers in the exciter multiply the channel element frequency to generate the desired output frequency signal(s). A controlled amplifier stage regulates the amount of signal drive to prevent over-dissipation in the final amplifier stages of the power amplifier. In continuous duty stations, an adjustable voltage regulator is used to set the output level of the controlled amplifier stage on the exciter to a certain set level. In intermittent duty stations, a variable voltage from the power control board continuously regulates the output level of the controlled amplifier stage on the exciter.

- Power Amplifier — The low power output of the exciter is amplified to the rated power output of the transmitter in this solid-state power amplifier. Class C amplifiers are used which are cut off until signal drive is applied.
- Power Control Board — In intermittent duty stations, the power control board automatically and instantaneously regulates the transmitter output power. It maintains output power should source voltage vary, and progressively reduces power when the VSWR increases. The output of the board is applied to controlled amplifier stages in the exciter. In continuous duty stations, the power control board performs the same functions as in intermittent duty stations except that the output of the board controls the controlled amplifier stage on the power amplifier.

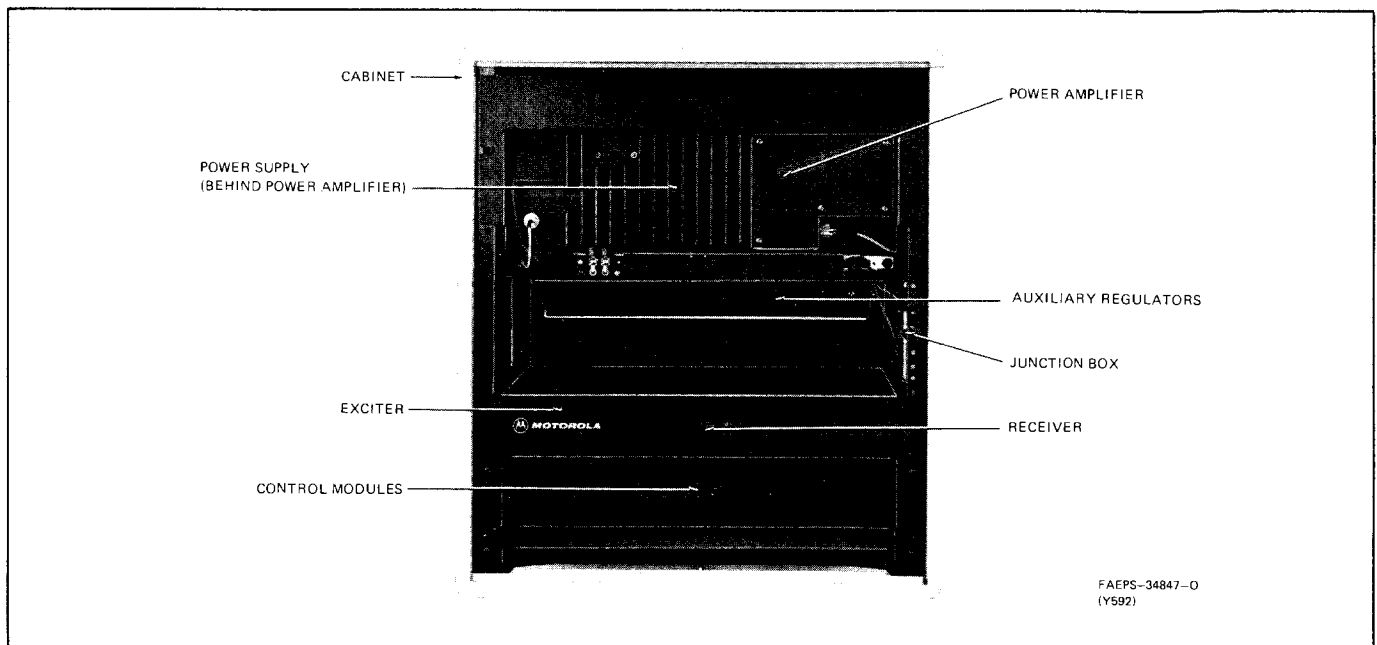

Figure 2. Basic Version of *MSR 2000* Base Station

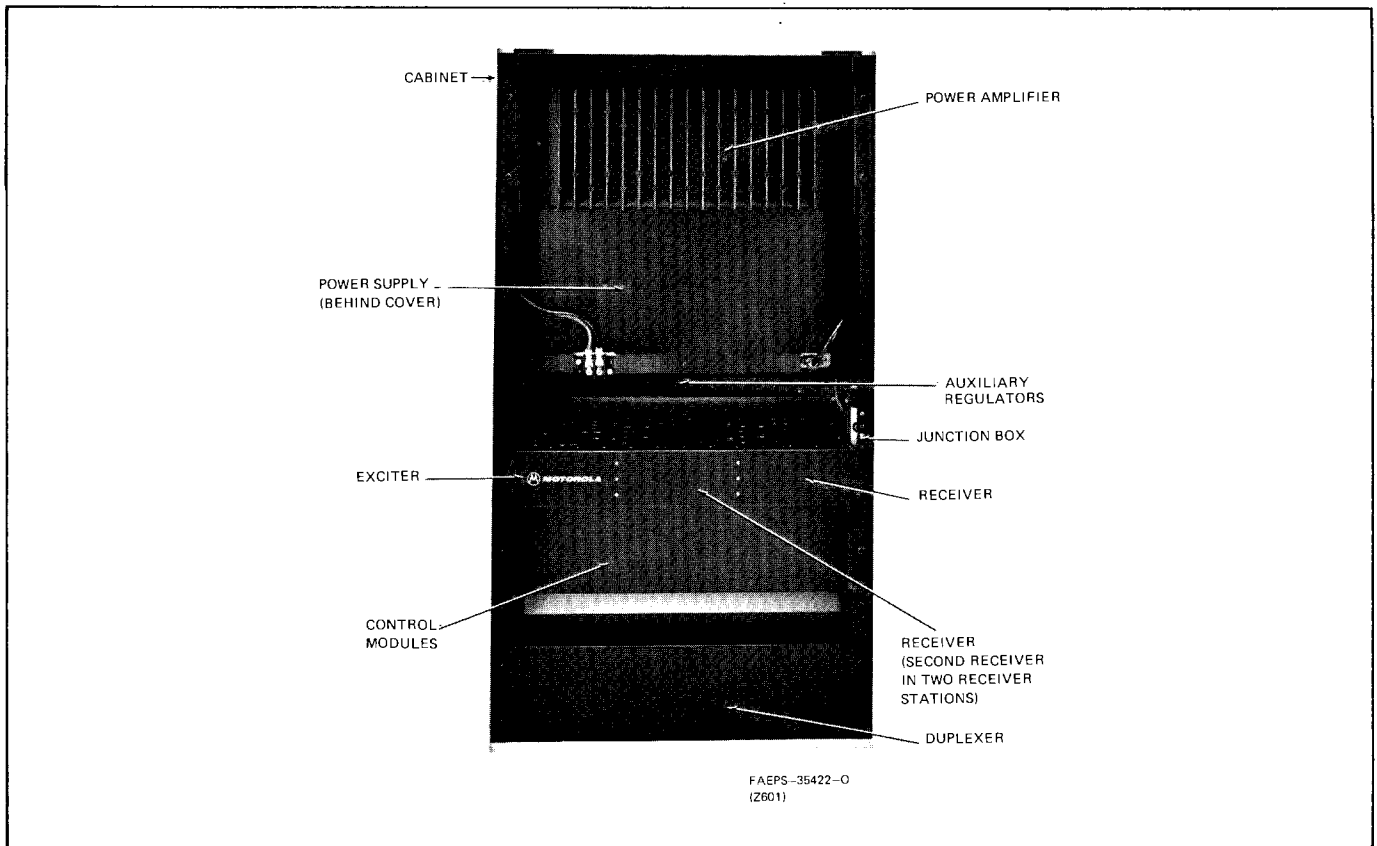

Figure 3. Optionable Version of Continuous Duty MSR 2000 Base Station (Repeater Model With Duplexer Option Shown)

### 3.2 RECEIVER

The receiver accepts rf carrier signals on a specific channel and provides voice audio in the 300-3000 Hz range. The receiver consists of the following items:

- Channel Element — A plug-in crystal oscillator module (channel element) provides stable frequency control for the frequency of operation. One channel element is required for each receiver frequency.
- Receiver RF & I-F Board — The single-conversion superheterodyne FM receiver includes a preselector (comprised of five cavities) and five crystal filters for excellent selectivity. Two integrated circuit i-f amplifiers and limiters give high sensitivity. A single chip quadrature detector demodulates the audio directly from a 10.7 MHz i-f signal.
- R1 Audio Board — The R1 audio board contains the carrier squelch circuitry and the 1 watt service audio amplifier. When no messages are being received, the squelch circuit turns off the audio amplifiers to eliminate annoying noise in the speaker. A squelch tail eliminator circuit prevents the noise burst at the end of a message for strong signals. For weak signals, the circuit is automatically inhibited to prevent loss of portions of messages. The service audio power amplifier consists of a single chip mounted on the R1 audio board.

- Receiver VOLUME and SQUELCH controls are located on the R1 audio board. The RECEIVER VOLUME control only affects local speaker operation (when used).

#### NOTE

The SQUELCH control affects local and remote operation.

### 3.3 POWER SUPPLY

The power supply normally installed in these stations, utilizes a ferro-resonant (constant voltage) transformer and provides all the voltages necessary for operating the station. It automatically corrects for changes in load and input voltage thus maintaining a constant voltage output. An optional supply is available which provides automatic emergency power (+12 V) reverting.

## 4. UNIQUE FEATURES

Both the basic and optionable versions of the MSR 2000 offer the following design features:

- Front Side Access of All Modules — Major modules tilt forward or slide out so that all necessary test points and metering sockets can be easily reached from the front of the enclosure.

- External Junction Box — AC power, antenna, 12 V dc battery revert option, auxiliary control, and phone line connections are made to an external junction box. No drilling or cutouts are required through the cabinet skin to access internal connections.
- Cooler Operation — Flow-through ventilation and “top-of-the-cabinet” mounting for both the PA and power supply result in cooler operating temperatures, thereby improving station reliability. Air intake is through the front door of the *MSR 2000* and exits on both sides, allowing cooler operation when stacking stations.
- Smaller Size — The *MSR 2000*, at 24 inches high, is much shorter than its predecessor stations, resulting in more space available at the site when stacking stations.
- One-Piece Wrap-Around Sides and Back — The one-piece vinyl clad steel wrapper used for the *MSR 2000* cabinet provides sealed-back enclosure for greater station security, and allows back-to-back installation configurations without the need for access corridors to the rear of the station. No access corridors can result in greater site densities and improved space utilization.

## 5. OPTIONS

5.1 The following options are available for either the basic or optionable version of the *MSR 2000* station.

- Time-Out Timer (C11 Option)

This limits transmissions to one of five pre-set time periods. These time periods are 1/2, 1, 2, 4, and 8 minutes. The time period desired for a particular system is determined by the user by means of two jumpers. One jumper determines the time period for console-generated transmissions and the second determines the repeat time of a mobile. This module is standard in all RT repeater models.

- RF Preamplifier (C12 Option)

The preamplifier doubles the usable sensitivity of the base station receiver, although this sensitivity can be fully realized only in low-noise, interference-free areas.

- 120 V AC/12 V DC With Charge, Alarm, Auto-Revert (C28 Option)

A 12 volt battery can be floated at the output of the station power supply for emergency power use. The battery will provide station power when the AC line fails. When the AC line is functioning it provides float-charging for the battery. Power supply senses

station switchover from 120 V ac to 12 V dc operation when loss of primary power occurs and alerts user via audio alarm.

- Service Intercom and Speaker (C226 Option)

Provides line intercom facilities to simplify servicing of the remote station.

- Test Mic (C113 Option)

Applies to option C226.

- DC Metering With Intercom and Mic (C149 Option)

Provides metering of transmitter and receiver circuits and line intercom facilities (remote control only) to simplify servicing of the remote station.

- Transmit PL On/Off for Paging (C63 and C276 Option)

C63 Option. This module allows any single frequency base station with *Private-Line* squelch to transmit with or without the PL tone on the transmitter at the operator's discretion. A standard paging encoder automatically actuates this function when used in conjunction with a tone console equipped with the corresponding option. This option is not available with the four-frequency remote station.

C276 Option allows transmit code to be different than receive code. Available for both PL and DPL.

- Delete Channel Elements
- Omit Receiver (C31 Option)
- TFN1017A or TFN1018A Crystal Filter (Field Install)

An rf crystal filter adds extra selectivity to the receiver to improve intermodulation protection and desensitization performance.

- AND Squelch (C140 Option)

AND Squelch operation is a means of using both the carrier squelch AND PL tone-coded squelches to operate the receiver. This allows the user to vary the coded squelch sensitivity with the squelch control. It is especially recommended for use in mixed systems where some PL transmitters do not send a reverse burst at the end of each transmission. This results in an annoying squelch tail as the reed coasts to a stop. AND squelch is not recommended for normal PL performance when the mobile may be in a fading area.

- 2 ppm stability on transmit and receive
- Four-Wire Audio Line Driver (C144 Option)

Provides separate audio line capability for duplex operation or two-receiver audio routing.

- 50-Watt Maritime Operation (C50 Option)

- Indoor Cabinet 29" (C92 Option)

This option is applicable to intermittent duty stations only.

- Indoor Cabinet 37" (C52 Option)

This option is applicable to continuous duty stations only.

- TLN5935A Extender Card

- Shield & Filter Kits (C116 Option)

Provides full filtering of all leads and shield covers for base stations only. Included on repeater and two-receiver models as a standard feature.

5.2 The following options are available for only the optionable version of *MSR 2000* stations.

- 4-Reed Multiple *Private-Line* (C158, C261, C262, C263 Options)

Provide 4 PL code capability and are equipped with a full set of *Vibrasender* and/or *Vibrasponder* resonant reeds.

- TLN2442A Singletone Decoder

This module may be used for additional security for repeaters or for repeater selection in multiple-repeater systems. By addition of the TLN4151A Relay Kit, other functions can be controlled by this module. This option is not available with the four-frequency remote station.

- Mute 2nd Receiver (C56 Option)

Allows the user to "mute and unmute" 2nd receiver for extended periods of time. Remember, R1 automatically mutes R2 (R1 priority) when R1 is "active" in the standard two-frequency transmit, two-receiver stations.

- Remote Squelch Set (C13 Option)

Allows selection of station receiver squelch to either of two pre-adjusted settings.

- Wild Card (C15 Option)

This module may be used for any electrically operated function. It provides transistor switch outputs, or, with the addition of one or two relay kits (TLN4151A) will provide two form "C" dry contact outputs. These Wild Card outputs can be used to turn on and off any auxiliary equipment the user may have at or near his base station site. Remember, these functions are done by remote control from his console.

- 4-Cavity Duplexer (C182 Option)

This option, when ordered with a repeater model, provides an in-cabinet 4-cavity duplexer. Cabinet supplied is 29 inches for intermittent duty or 37" for continuous duty and included in this option (132-174 MHz).

- Receiver PL On/Off (C14 Option)

Provides remote control of receive PL on/off. With receive PL off, station reverts to carrier squelch operation.

- *Spectra-TAC* Encoder (C269 Option)

Includes 4-wire audio. Encoder module sends a status tone down control lines when receiver is squelched. This signal is used by the comparator in a *Spectra-TAC* system to effect voting of receivers.

- TKN8281A External Interface Cable

This ten-conductor cable allows routing of available control signals from back of rf control card cage to auxiliary control connector on station junction box.

**NOTE**

Some of the options described above are not compatible with other options. Option compatibility is computer assigned at the factory. Contact your local Motorola representative for further information.

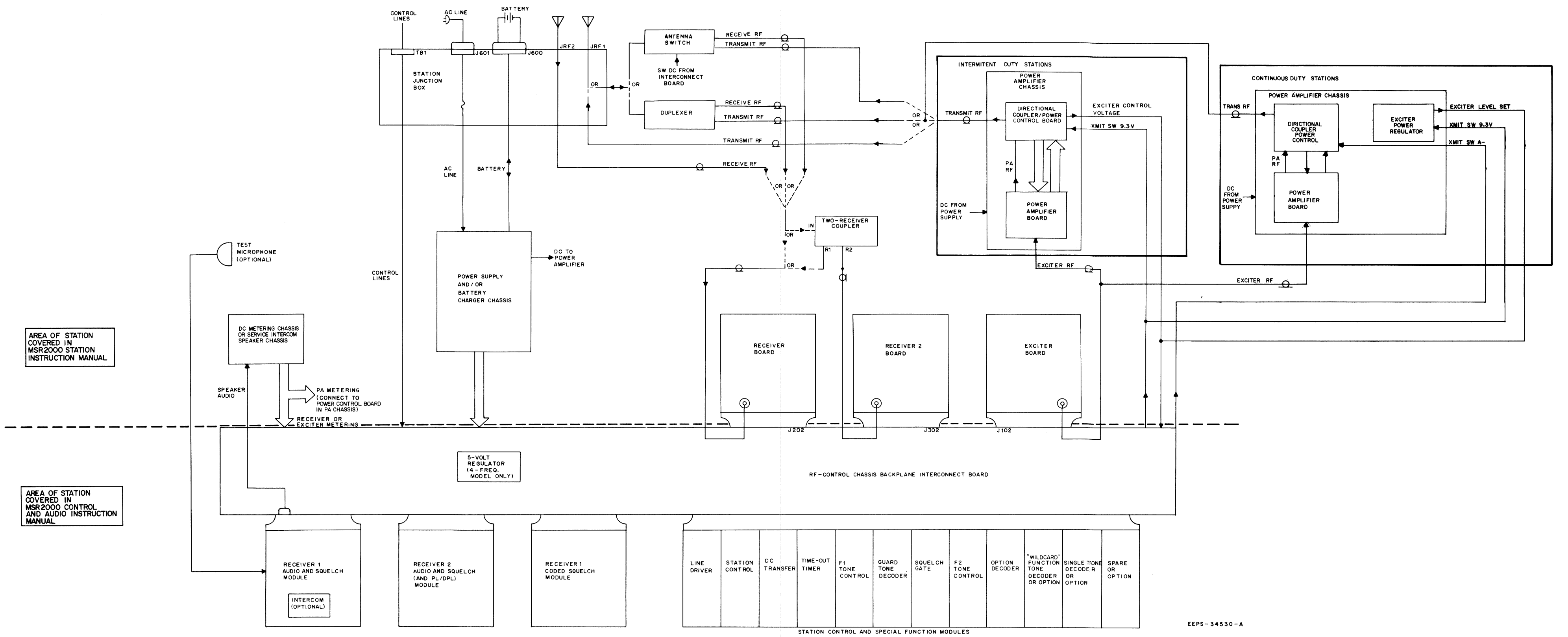

Figure 4. Simplified Block Diagram



**MOTOROLA INC.**

**Communications  
Group**

## LIGHTNING PROTECTION RECOMMENDATIONS

The conditions that make a site desirable for two-way radio are the same as those that make a site an excellent target for lightning. Proper lightning protection can completely prevent equipment damage in all but the most severe strikes and even then keep the equipment damage at a minimum. Lightning protection basically consists of preventing the strike from entering the equipment room and then preventing damage to the equipment from induced voltages and currents on power and control lines to the equipment. The following suggestions will help protect valuable radio facilities. Some products already incorporate certain suppressors as standard equipment. In these cases, additional protection is not normally required, unless dictated by unique site considerations. When such unique situations occur, consult the appropriate area office for further information.

- Use at least eight-foot long copper clad ground rods. Multiple ground rods are better than one especially in dry climate or sandy-rocky soil areas.
- Bring the transmission line off the tower with the sharpest bend permitted by the manufacturer's specifications and make a solid bond between the tower and transmission line sheath just prior to the bend. The sharp bend acts as a spot impedance to the extremely high strike current. This shunts more of the strike current into the tower ground rather than into the equipment. Use no more or no less than the minimum bend radius wherever the transmission line changes direction and introduce a change of direction at every reasonable opportunity. Then, ground the transmission line sheath at the antenna side of each bend in the transmission line.
- Provide additional grounding to the transmission line sheath wherever possible. Make it a point to ground the transmission line where it is supported on poles and where it enters a building.
- Keep the tower grounding resistance as low as possible. The lightning stroke current belongs in the tower structure and grounding system, not on the transmission line.

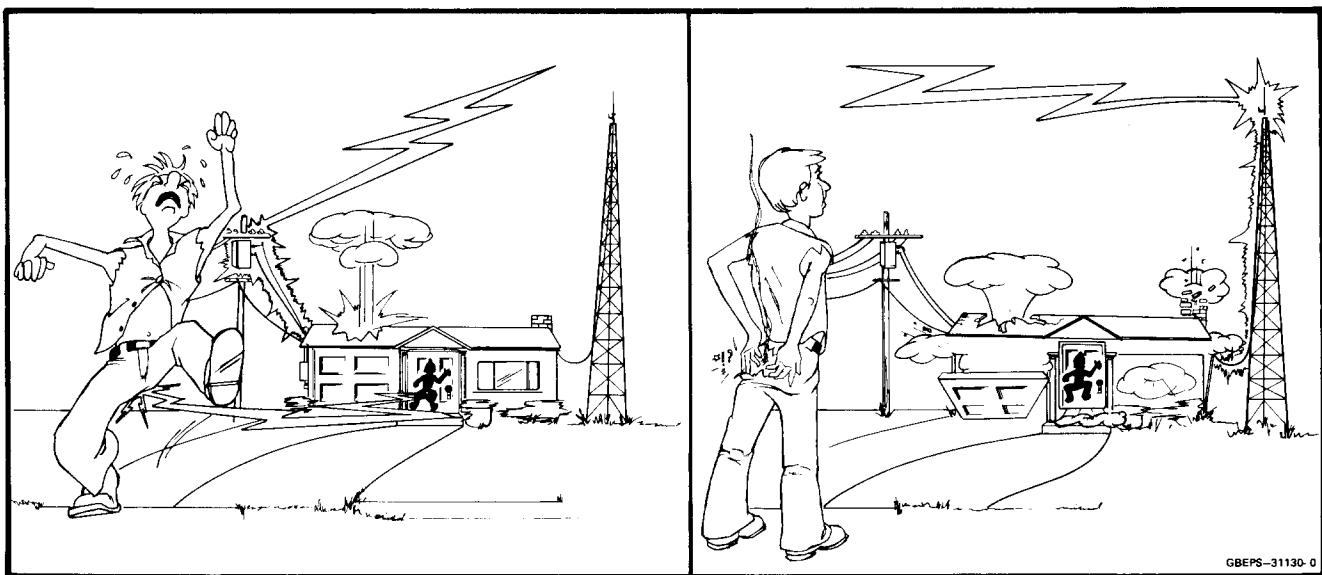

*Unprotected power/control lines and antenna installations can be hazardous to equipment and personnel.*

- It is wise to take at least part of the transmission line through a length of grounded conduit.
- **Bond all equipment cabinets together to a single point.** Then, ground that point to a grounding rod network using as short and as straight a ground wire as possible. If bends in the ground wire are necessary, make them as large a radius as practical.
- Transmission lines should be brought into the equipment cabinets adjacent to the single point ground connection where a good low impedance bond can be made with the transmission line sheath.
- Install a gas tube protector between the equipment cabinet ground and AC-neutral where it enters the equipment cabinet. Install gas tube protectors where the control lines enter the building and at the point of entry into the equipment cabinet. Also, install gas tube protectors wherever control lines enter a building and install additional protectors as close to the remote control console as possible.
- Keep ground wires from gas tube protectors to ground rods or perimeter grounds as straight and short as possible. Avoid sharp bends in ground wires.
- Never bundle a ground wire with any other cabling or wiring. Also, never run a ground wire along any metal wall, along any electrical conduit, or inside a conduit.

Remember, the lower impedance the grounding system is in relation to the equipment being protected, the greater the protection afforded to the equipment. Keep the lightning strike current in the grounding network; not running through the equipment to ground.

#### RECOMMENDED PROTECTORS

The devices listed below are available from your local Motorola Parts Center. Other devices are available from different manufacturers for special applications and may be used in place of those listed herein. Installation instructions are generally packed with each device. The following listing contains phone line suppressors, ac line surge protectors, coaxial cable in-line lightning arrestors, and coaxial cable ground clamp kits. Refer to the Motorola Buyers Guide for additional information.

#### PHONE LINE SUPPRESSORS

**TRN8187A** Single Line Suppressor, 3-electrode gas tube protector

**TRN4589A** Dual Line Suppressor, 3-electrode gas tube protector

**RRX4021B** Single Line Suppressor, 3-electrode gas tube protector

#### AC LINE SURGE PROTECTORS

**TLN4399A** AC Line Surge Protector, 117 V ac line, 7/8" x 14 conduit hole mounting

**TLN5920A** AC Line Surge Protector, 240 V ac line, 7/8" x 14 conduit hole mounting

**RRX4017A** AC Line Surge Protector, 117 V ac, 10 Amp, single phase, screw terminal connector block

**RRX4018A** AC Line Surge Protector, 117 V ac, 10 Amp, single phase, 3-prong plug and receptacle

**RRX4019A** AC Line Surge Protector, 117 V ac, 15 Amp, single phase, 3-prong plug and receptacle

**RRX4020A** AC Line Surge Protector, 220/240 V ac, 30 Amp, single phase

#### COAXIAL CABLE IN-LINE LIGHTNING ARRESTORS

**RRX4024** UHF type connector

**RRX4025** "N" type connector

**RRX4032** Tower Mount Kit

#### COAXIAL CABLE GROUND CLAMP KITS

**ST-788** For 1/2" jacketed heliax and pipe or grounding rod

**ST-853** For 7/8" jacketed heliax and pipe or grounding rod

**ST-789** For 1/2" unjacketed heliax, includes bushings for better contact without collapsing line

**ST-790** For 7/8" unjacketed heliax, includes bushings for better contact without collapsing line





INSTALLATION NOTES

LOCATION

CABINET REQUIRES A MINIMUM OF 6-INCHES CLEARANCE BETWEEN LOUVERED SIDE-PANELS AND EXISTING SURFACES FOR PROPER VENTILATION. ALLOW A MINIMUM OF 72-INCHES ACCESS SPACE AT THE CABINET DOOR.

FIXED MOUNTING (SEE DETAIL A)

IF DESIRED (BUT NOT NECESSARY UNLESS STACKING CABINETS), THE CABINET CAN BE SECURED TO THE FLOOR USING TWO M8 OR 5/16" BOLTS OF THE APPROPRIATE LENGTH INSERTED THROUGH THE CENTER HOLES OF THE BOTTOM RAILS.

STACKING CABINETS (SEE DETAIL B)

REMOVE THE MIDDLE TWO BOLTS (M8 X 40 MM) FROM THE TOP COVER OF THE BOTTOM CABINET AND SAVE THE BOLTS.

CAREFULLY LIFT AND PLACE THE SECOND CABINET IN POSITION ON TOP OF THE LOWER CABINET.

TILT OUT THE CARD CAGE IN THE TOP CABINET AND INSERT THE TWO BOLTS REMOVED EARLIER FROM THE BOTTOM CABINET INTO THE CENTER HOLES OF THE BOTTOM RAILS AND SCREW THEM INTO THE TOP RAILS OF THE BOTTOM CABINET.

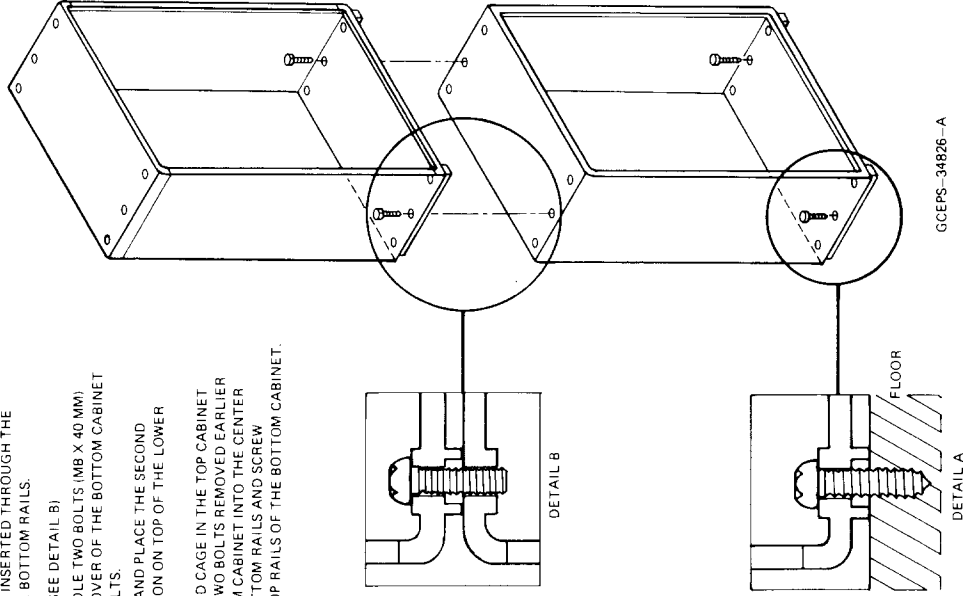

6CEPS-34826-A

CABINET TOP BOLTS

| QTY. | PART NO.   | DESCRIPTION          |
|------|------------|----------------------|
| 4    | 0310943J41 | M8 X 16 MM TORX BOLT |
| 2    | 0310943J45 | M8 X 40 MM TORX BOLT |

HEIGHT DIMENSION TABLE

| CABINET SIZE | HEIGHT DIMENSION |
|--------------|------------------|
| 24-INCH      | 24.04 INCHES     |
| 29-INCH      | 29.29 INCHES     |
| 32-INCH      | 32.04 INCHES     |
| 37-INCH      | 37.29 INCHES     |

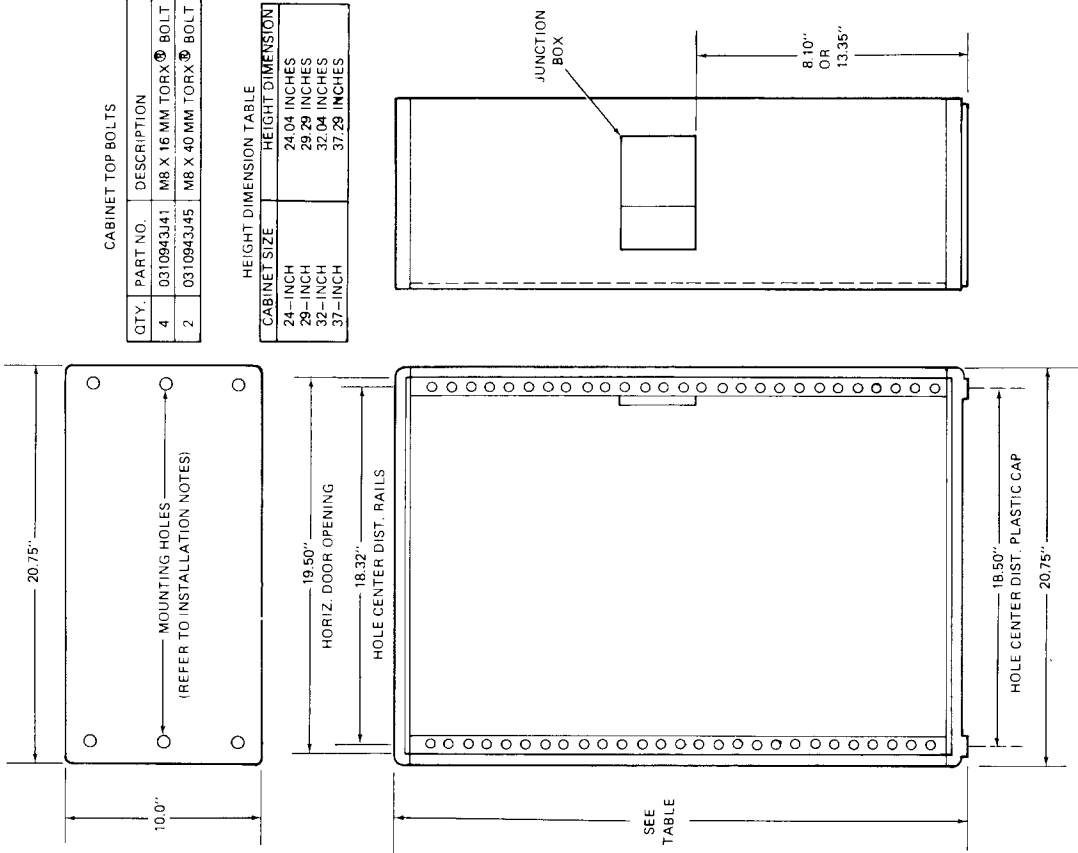

Figure 1. Cabinet Dimensional Details

**CAUTION**

It is recommended that no additional holes be drilled into the cabinet.

5.4 Refer to Figure 1 for mounting and stacking details.

**NOTE**

In stacking configurations, the transmitter hum and noise may degrade up to 10 dB if the station directly below has a battery revert power supply (C28 option).

**6. ANTENNA CONNECTIONS**

6.1 The antennas and transmission lines are not part of the station. Therefore, antenna installation instructions are not included in this section. Follow the instructions shipped with the antenna for applicable information.

6.2 In its primary application, the station is used for communications with mobile radios. Thus, antennas having omni-directional characteristics are desirable.

However, if the station is located at the outer perimeter of a communications area, or if it is to be used for communications with a fixed station, an antenna with specific directional characteristics may be more suitable. FCC requirements may also dictate the type of antenna to be used.

6.3 All coaxial antenna cables connect to UHF coaxial connectors located on the junction box. For repeater stations without the optional duplexer, two antennas are required; one for the transmitter and one for the receiver. For repeater stations with the optional duplexer, only one antenna is required. Refer to Figure 2 for antenna connection details.

**7. AC INPUT POWER AND GROUND CONNECTIONS**

**7.1 INTRODUCTION**

7.1.1 All stations should have a separate power circuit from a 10-ampere (minimum), 120-volt ac, 60 Hz power source. The power lines should be installed in accordance with local electrical codes. A substantial earth ground must be provided as close to and in as straight a

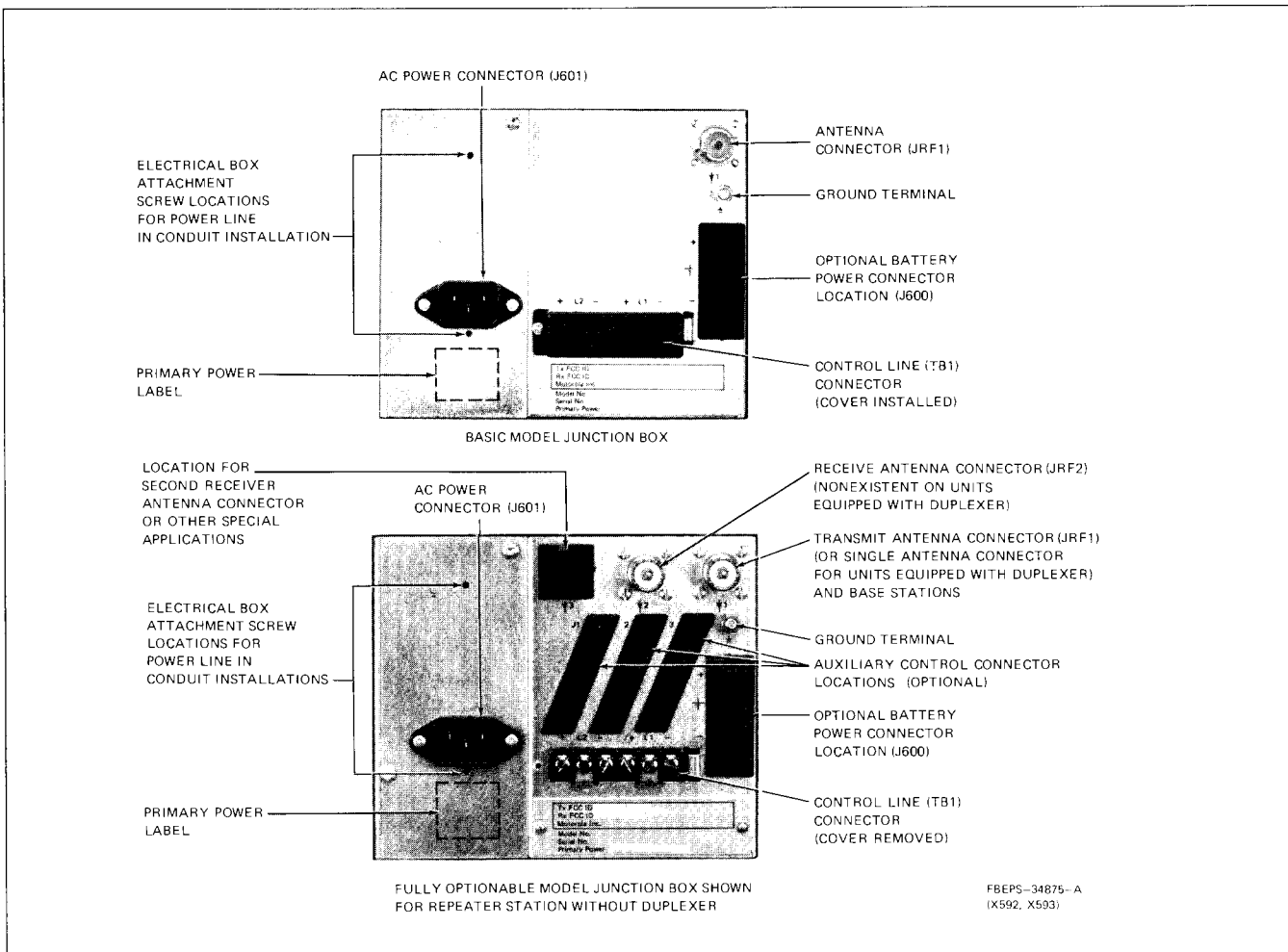

Figure 2. External Connection Details

line as possible with the ground terminal provided on the junction box. Do NOT consider the electrical outlet box as a substantial ground. Refer to the Lightning Protection Recommendation sheet, 68P81111E17 in this installation section for additional grounding recommendations.

**7.1.2** The primary ac power line may be installed prior to installation of the cabinet and terminated near the location chosen for the station if the power line cord supplied with the station is to be used. If the station power is to be supplied by conduit wiring, the station must be installed first. Separate procedures are provided for each type of installation in the following.

## 7.2 STATION INSTALLATION USING POWER LINE CORD SUPPLIED WITH THE STATION

Step 1. Install the station as described in paragraph 5.

Step 2. Connect the female plug of three-wire ac line cord to the power connector on the junction box. See Figure 2.

Step 3. Connect the male plug of the three-wire ac line cord to the wall outlet provided near the station.

Step 4. Connect the ground terminal on the junction box to a substantial earth ground located as close as possible to the station and in as straight a line as possible with the ground terminal.

### NOTE

A power ON-OFF switch is not provided on the station, therefore, the equipment is immediately operational when the power cord is plugged into a live ac outlet.

### WARNING

Even if a three wire grounded primary ac power source is available, the radio equipment **must be grounded** separately to prevent electrical shock hazards and provide lightning protection.

## 7.3 STATION INSTALLATION USING CONDUIT FOR PRIMARY POWER CONNECTION

The *MSR 2000* junction box has provisions which allow ac power connection to the station using conduit. The following installation procedure is recommended.

Step 1. Remove the two screws attaching the ac input connector (J611) to the junction box and carefully pull the connector away from the junction box.

Step 2. Cut the wires as close as possible to the ac input connector (J611).

Step 3. Strip the insulation from the wires a sufficient length to allow connection to the incoming power leads.

Step 4. Attach a 4-1/8" × 2-3/8" × 1-1/2" electrical box (Appleton Catalogue No. 184-E universal code 69351 or equivalent box extension ring, not supplied) to the junction box using two #6-32 × 5/16" long self tapping washer head screws in the holes provided. See Figure 2.

Step 5. Attach the conduit to the electrical box and make the electrical connections. (It may be desirable to provide an ON-OFF switch or convenience outlet on the electrical box).

### NOTE

The primary power wire colors used in the *MSR 2000* conform to international standards. Refer to the following cross reference table as required.

| Power Connection | International STD Wire Color | US Standard Wire Color |
|------------------|------------------------------|------------------------|
| Live             | Brown                        | Black                  |
| Neutral          | Blue                         | White                  |
| Ground           | Green/Yellow                 | Green                  |

Step 6. Attach a suitable cover to the electrical box.

## 8. OPTIONAL DC INPUT POWER CONNECTIONS

Connection of the optional dc input power requires assembly of the TRN5155A External Battery Cable Kit. This kit includes a fuse block assembly that must be mounted to the base station along with wires and terminals that must be assembled and connected to the external battery. Install as follows:

Step 1. Determine the length of black #8 gauge wire required to run from P605 directly to the battery negative terminal. Route and cut the black wire to length. A ring tongue lug is provided to facilitate connecting the wire to the battery.

### NOTE

The TRN5155A External Battery Cable kit contains 10 feet of red and black #8 gauge wire. Runs longer than 10 feet are not recommended for efficient battery operation. If runs longer than 10 feet are necessary, increase the wire gauge by 3 AWG for each increase of 10 feet in run length.

Step 2. Make sure all power is disconnected from the station.



### 10.2.1 DC Remote Control Operation

#### Audio Line Requirements

1. Frequency Response:  
500 to 2500 Hz
2. Impedance:  
600-ohm balanced line

#### DC Line Requirements

1. DC resistance 0 to 8000 ohms
2. Must have dc continuity

### 10.2.2 Tone Remote Control Operation

Frequency response: 500 to 2500 Hz  
Frequency translation error:  $\pm 10$  Hz max.  
Impedance; 600-ohm balanced line  
Signal-to-noise: 35 dB min.

*Chart of Maximum Input and Loss*

| Phone-Company Specified Maximum Input | Maximum Phone Line Loss Usable with Remotely-Controlled Radio |
|---------------------------------------|---|
| 5 vu (11 dBm)                         | 29 dB   |
| 0 vu (6 dBm)                          | 24 dB   |
| -8 vu (-2 dBm)                        | 16 dB   |

## 10.3 INSTALLATION

### 10.3.1 General

The control line may be installed prior to installation of the cabinet and terminated near the location chosen for the station. Conduit or two-wire cable can be used from this termination to the station junction box control line connector.

### 10.3.2 Specific Connection Information

Connect the 600-ohm lines to the screw terminals on the junction box control line connector as shown in Figure 2. (In 2-wire applications, use line 1 connections.)

### 10.3.3 DC Control Line Levels

When the dc control line is initially connected, it must be tested to assure that its loop resistance is low enough to allow sufficient current for remote operation. Use the following test procedure.

Step 1. Connect a dc milliammeter in series with the dc control line.

Step 2. Have the operator press the push-to-talk switch at the remote control console.

Step 3. The current must be at least +5.5 mA to key the transmitter and at least +10 mA for two-frequency transmitters. Check to see that the current is positive and not negative and that the station is actually keyed. Adjust the remote control console for F1 line current

until +5.5 mA is achieved. For a two-frequency transmitter, adjust the remote control console for F2 line current of 10 to 12 mA. If the line loop resistance is too high, the maximum line current from the console will not key the transmitter. There are two alternatives to correct this problem.

- Use a pair of lines having lower resistance while maintaining proper audio response, or
- Use an alternate pair of lines with lower resistance to carry dc current only. This pair need not have good audio loss or response characteristics.

Adjust the line current for *Private-Line* disable at the remote control console for -2.5 mA, if a *Private-Line* model is being adjusted.

### 10.3.4 Tone Control Line Levels

The control tone levels for the remotely controlled functions are adjusted at the remote control console. No additional adjustments are required.

## 11. CONTROL LINE LEVEL ADJUSTMENT

### 11.1 GENERAL INFORMATION

**11.1.1** Most telephone companies limit the maximum signal amplitude which they will allow on their lines. The most common maximum level is 0 vu (volume units); check the telephone company for the maximum level to be used on your lines. Adjust the audio levels to the maximum permissible level which will give the best signal-to-noise ratio. For lines not subject to telephone company restrictions, set line level to +5 vu.

**11.1.2** The vu is the measurement for speech and can be measured only with a vu meter. This meter has special ballistics to control the rise and fall time and the overshoot of speech signal voltage. Since speech signals fluctuate so rapidly, special metering techniques are required. The pointer of a vu meter responds to a series of "kicks" or deflections of varying amplitude. Over a period of time, a majority of peaks will reach approximately the same level. There will be a few very strong peaks which will exceed this level and a few peaks of lower level. These are ignored and the measured speech level equals the majority of the "kicks" or peaks reached. Measurements show that the instantaneous peaks of a speech signal are about 10 dB higher than the vu value (the instantaneous peaks of a 0 vu speech signal will equal the peaks of a sine wave signal of  $\pm 10$  dBm magnitude). Of course, a sine wave signal of  $\pm 10$  dBm would produce a much greater volume because every cycle of the signal goes to peak amplitude.

**11.1.3** Adjustment of the audio line levels is very difficult using actual speech signals which fluctuate so greatly. A sine wave signal (1000 Hz continuous tone, for example) is much easier to use for adjustments.

However, sine wave signals are measured in dBm and the telephone company specifies the maximum signal level in vu. **THERE IS NO CONVERSION FROM VU TO DBM OR VICE VERSA** when measuring speech. Speech cannot be measured in dBm or converted into dBm. The dBm is a unit to measure the sine wave power as referenced to 1 milliwatt of power. The power of a speech signal of a particular vu is not defined and is different for different speakers. **IT IS POSSIBLE TO CALIBRATE A VU METER BY USING A SINE WAVE SIGNAL ON THE 600-OHM LINE, THEN MEASURING THE SAME SIGNAL IN DBM WITH A VOLTMETER.** On a 600-ohm line, a sine wave signal that will produce a 0 vu reading will measure 0 dBm on a voltmeter. This does not mean that 0 vu is equal to 0 dBm. Remember, the peaks of an actual 0 vu **speech** signal will have instantaneous peaks of + 10 dBm amplitude.

**11.1.4** We would normally conclude that sine wave signal levels would be adjusted 10 dB higher than the vu level specified for the line. **EXPERIMENTAL MEASUREMENTS HAVE PROVEN THAT SINE WAVE SIGNAL LINE LEVELS SHOULD BE 6 DB HIGHER THAN THE VU LEVEL SPECIFIED FOR THE LINE** (+ 5 vu speech level should be adjusted for + 11 dBm tone level; 0 vu speech level should be adjusted for + 6 dBm tone level).

*600-Ohm Line VU, dBm, and Voltage Equivalency Chart*

| If Maximum Speech Level For Line Is | Adjust Tone Line Level For (1 mW ref) | Voltage Equivalent |
|-------------------------------------|---------------------------------------|--------------------|
| + 5 vu                              | + 11 dBm                              | 2.78 V             |
| + 2 vu                              | + 8 dBm                               | 1.94 V             |
| 0 vu                                | + 6 dBm                               | 1.54 V             |
| -2 vu                               | + 4 dBm                               | 1.22 V             |
| -4 vu                               | + 2 dBm                               | 0.97 V             |
| -6 vu                               | 0 dBm                                 | 0.77 V             |
| -8 vu                               | -2 dBm                                | 0.61 V             |
| -10 vu                              | -4 dBm                                | 0.48 V             |
| -12 vu                              | -6 dBm                                | 0.38 V             |
| -14 vu                              | -8 dBm                                | 0.30 V             |
| -16 vu                              | -10 dBm                               | 0.24 V             |
| -18 vu                              | -12 dBm                               | 0.19 V             |
| -20 vu                              | -14 dBm                               | 0.15 V             |
| -22 vu                              | -16 dBm                               | 0.12 V             |
| -24 vu                              | -18 dBm                               | 0.09 V             |
| -26 vu                              | -20 dBm                               | 0.07 V             |

**11.2 ADJUSTMENTS**

**11.2.1 General**

**11.2.1.1** A local speaker at the station may be used for testing and level settings. If the station is equipped with built-in metering, it includes a local speaker. If not, the speaker in a Motorola portable test set may be used by connecting the test set to the control receptacle on the unified chassis interconnect board. Otherwise, a mobile

speaker can be connected to the local speaker pins (pins 22 and 23 of R1 audio module on the unified chassis interconnect board). The receiver **VOLUME** control sets the audio level at the local speaker only.

**11.2.1.2** Exciter audio should be measured at the input to the exciter and adjusted for the sensitivity value stamped on the exciter's sensitivity label located on the inside of the control card cover. This level should be measured at pins 11 and 12 of the exciter board plug.

**11.2.1.3** *Private-Line* receivers must be PL disabled during adjustments by using the PL **DISABLE** switch on the station control module. In *Private-Line* repeaters, the squelch gate must also be set for carrier squelch operation during adjustments by connecting jumper JU14 to the active pin and JU15 to the dummy pin. Be sure to return the jumpers to the PL condition after adjustments are complete.

**11.2.1.4** If the station is equipped with a single-tone decoder module for repeater access, unplug the single-tone decoder during adjustments.

**11.2.2 Repeater Level Setting**

Step 1. Set the receiver **SQUELCH** control at squelch threshold.

Step 2. Inject an on-frequency carrier signal into the receiver antenna input. Adjust the signal level to 20 dB quieting.

Step 3. Adjust the **REPEATER SQUELCH KEY** control (squelch gate module) so the transmitter just keys.

Step 4. Modulate the receiver input with a 1000 Hz tone at ± 5 kHz deviation. Adjust the **REPEATER LEVEL** control (squelch gate module) so the exciter audio input (measured at pins 11 and 12 of the exciter board) is the value stamped on the exciter sensitivity label (modulator sensitivity + 6 dB or approximately ± 5 kHz transmitter deviation).

Step 5. On PL repeaters, return jumpers JU14 and JU15 to the PL condition.

**11.2.3 Wire Line Controlled Base Stations and Repeater Stations**

**11.2.3.1** Determine the maximum allowable audio level permitted on the lines and set line audio level to this amplitude. Refer to the 600 ohm, vu, dBm and voltage equivalency chart for tone levels to be used.

**NOTE**

The following procedures assume the + 5 vu speech level (+ 11 dBm tone level). For other speech levels, use a tone level 6 dB higher than the vu level (for 0 vu use + 6 dBm); refer to the equivalency chart. On some lines, tone levels are not permitted

**NOTE (Cont'd.)**

to exceed the speech levels, even for short test tones (for example, maximum speech level of 0 vu and maximum tone level of 0 dBm). When such regulations apply, use the special procedures for low level test tone.

**11.2.3.2** As mentioned previously, the lines used to carry audio have an ac impedance of 600 ohms. The amplitude of signals is most conveniently measured in dBm. Zero dBm is equal to 1 milliwatt across 600 ohms. Most audio voltmeters, such as the Motorola transistorized ac voltmeter, are calibrated to read directly in dBm when measuring across a 600-ohm impedance. Never use a volt-ohm meter or a multimeter.

Step 1. Apply a 1000 Hz audio tone to the remote control console at a level sufficient to drive the amplifier into compression. Adjust the output of the remote control console for +11 dBm (or maximum allowable audio level) at its output terminals. If the level at the station is above 0 dBm, remove JU1 on the station control module.

Step 2. Adjust the XCTR LEVEL control (state control module) so the exciter audio input (measured at pin 11 and 12 of the exciter board) equals the value stamped on the exciter. (Modulator sensitivity plus 3 dB or approximately +5 kHz transmitter deviation.)

Step 3. Remove the 1000 Hz audio tone.

Step 4. Set the receiver SQUELCH control for squelch threshold.

Step 5. Inject a 1000 mV carrier frequency signal into the antenna input of the receiver. Modulate the signal with a 1000 Hz tone at + kHz deviation.

Step 6. Adjust the LINE 1 OUTPUT/line driver module) for +11 dBm (2.8 V) or maximum allowable audio level as measured with an audio voltmeter across the line 1 terminals. If four-wire audio operation is used, with the receiver output applied to line 2, adjust the LINE 2 OUTPUT control while measuring across the line 2 terminals.

Step 7. If the station has two receivers, both feeding to line 1, set the LINE 1 OUTPUT control as specified with a +5 kHz modulated carrier signal injected into receiver 1. Next, inject a  $\pm 5$  kHz modulated carrier into receiver 2. If the line output on the voltmeter changes by more than 2 dBm, readjust the potentiometer on the receiver 2 audio and squelch board to match the receiver 1 reading.

Step 8. If the station has two receivers, each on a different line, adjust LINE 1 OUTPUT with a modulated

carrier injected into receiver 1, and adjust LINE 2 OUTPUT with a modulated carrier injected into receiver 2.

**11.2.4 Special Procedure for Low Level Test Tone**

**NOTE**

The following procedure is written for the vu speech level and 0 dBm test tone level, but other levels may be used by substituting appropriate levels (levels across the 600-ohm load should be 6 dB higher than the specified line level).

Step 1. Terminate the remote control console in a 600-ohm load resistor rather than the line.

Step 2. Apply a 1000 Hz audio tone to remote control console at a level sufficient to drive the amplifier into compression.

Step 3. Connect an audio voltmeter across the 600 ohm load resistor and adjust the line output for +6 dBm.

Step 4. Reduce the 1000 Hz audio tone input until the voltmeter reads 0 dBm.

Step 5. Remove the 600 ohm load resistor and reconnect the line. Readjust the line output for 0 dBm across the line. Do not change the 1000 Hz tone level.

Step 6. Connect the audio voltmeter to the exciter audio input at the station and adjust the XCTR LEVEL control for 6 dB less than the value stamped on the exciter.

Step 7. Disconnect the line at the station and connect a 600 ohm load resistor in its place.

Step 8. Apply a 1000 uV carrier signal to the receiver antenna terminal from an FM signal generator. Modulate the carrier signal with a 1000 Hz tone at  $\pm 5$  kHz deviation.

Step 9. Connect an audio voltmeter across the 600 ohm load resistor and adjust the LINE 1 OUTPUT control for +6 dBm.

Step 10. Reduce the deviation until the voltmeter reads 0 dBm.

Step 11. Remove the 600 ohm load resistor and reconnect the line. Readjust the LINE 1 OUTPUT for 0 dBm as measured across the line.



**1. INTRODUCTION**

**1.1** This section of the manual details procedures required in the overall maintenance of the station. Specific troubleshooting and alignment procedures are given in the appropriate section of this manual, such as receiver, transmitter, etc. Maintenance checks for control modules are given in the applicable module section in the separate Control and Audio Instruction Manual 68P81061E40.

**1.2** The first section gives the procedures required to locally operate the station during servicing. This allows service personnel to operate all functions of the station without an operator present at the control site.

**1.3** The second section provides a list of routine maintenance procedures that should be performed periodically or whenever the station is serviced. Also, a list of recommended test equipment is provided.

**1.4** The last section explains how to disassemble and gain access to the various parts of the station and contains the station mechanical parts identification and station intercabling diagrams. This station is designed for easy service access. Usually, all servicing can be performed with the housing in place on the station by removing only the locking front cover.

**2. LOCAL OPERATION**

**2.1 GENERAL**

Once power is applied and the station is properly adjusted, the base or repeater station is normally operated entirely unattended from a remote control point. The station may be manually operated utilizing controls on the control modules in the station chassis. This type of operation may be necessary to accomplish station maintenance and testing. The switch functions are given in Table 1.

**WARNING**

The transmitter can be keyed remotely. To prevent unexpected transmitter keying while servicing the station, be sure the LINE DISABLE switch is actuated (direction of arrow). Also, the TRN5324A Squelch Gate Module must be temporarily removed from the remote control chassis if the station is equipped with any of the following dc transfer modules:

- TRN5329A
- TRN5240A
- TRN5257A

To prevent PA damage, be sure the **LINE DISABLE** switch is actuated and do not locally key the station while having more than one channel element selected.

*Table 1. Station Control Module Switch Functions*

| Switch  | Position                 | Functions Possible  |
|---|--------------------------|---|
| XMIT  | Normal (not actuated)    | Normal mode of operation  |
|   | Actuated (hold to right) | Turns transmitter on with no modulation. Use test microphone connected to Local Mic receptacle to modulate transmitter. |
| PL DISABLE* (functional only in <i>Private-Line</i> stations or <i>Digital Private-Line</i> ) | Normal (left)            | Only PL/DPL-coded on-frequency signals accepted by receiver.  |
|   | Actuated (right)         | All on-frequency signals accepted by receiver.  |
| LINE DISABLE*   | Normal (left)            | Transmitter can be operated by:<br>1. XMIT switch<br>2. Local microphone<br>3. Remote control console                   |
|   | Actuated (right)         | Transmitter can <i>not</i> be operated by remote control console over control line.                                     |

\*The DISABLE LIGHT is illuminated when the LINE DISABLE or PL DISABLE switch is actuated.



The following procedures pertain to the local operation of a remotely controlled station or repeater station.

## 2.2 TRANSMITTER CONTROL

To prevent the transmitter from being keyed remotely, set station control module LINE DISABLE switch in the direction of the arrow. At conclusion of local operation, be sure that the LINE DISABLE switch is returned to its normal position (opposite direction of arrow).

## 2.3 LOCAL MICROPHONE

Connect a microphone (Motorola Model TMN5064A or equivalent) to the microphone receptacle on the R1 Audio Module. This microphone may be used as a local microphone, and to key the transmitter.

## 2.4 LOCAL SPEAKER

### 2.4.1 Stations Without Optional Speaker or Meter and Speaker Box

Connect an 8-ohm, 1-watt test speaker to pins 22 (+) and 23 (-) at the R1 Audio Module edge connector on the station backplane interconnect board. This speaker is used to monitor all received messages.

### 2.4.2 Stations With Optional Speaker or Meter and Speaker Box

Connect the speaker lead from the speaker box to pins 22 (+) and 23 (-) of the R1 Audio Module edge connector on the station backplane interconnect board. Place the Speaker On-Off switch to the On position. The Speaker On-Off switch is located on the side of the Speaker or Meter and Speaker Box mounted toward the back of the station. The box may be removed from its mounting in the station for access.

## 2.5 HANDSET

A Motorola handset (Model TMN6057A) may be used to provide local audio, microphone, and transmit push-to-talk. Connect the handset to the microphone receptacle on the R1 Audio Module.

## 2.6 PORTABLE TEST SET (FOR STATIONS WITHOUT BUILT-IN METERING)

A Motorola S1056-S1059 Series Portable Test Set with TEK-37 or TEK-37A Adapter Cable can be used as a local control facility. Connect the red "control" plug of the adapter cable to the metering receptacle on the unified chassis interconnect board. The speaker in the test set can be used for monitoring received signals and an optional microphone (Model TMN6054A) connected to the microphone receptacle on the test set can be used for originating transmissions. The XMIT button on the test set can be used to key the transmitter without voice modulation.

## 2.7 FREQUENCY SELECTION

For stations with a two-frequency transmitter, the frequency can be locally selected by the F1-F2 switch on the dc transfer module or on the F2 tone decoder module. For stations with a two-frequency receiver, frequency selection is made by momentarily operating the REC F1 SELECT or REC F2 SELECT switch on the dc transfer module or on the F2 tone decoder module. For four-frequency stations, the frequency is selected by *momentary* operation of the desired frequency select switch on the four-frequency control module *after* the XMIT switch on the station control module is actuated.

## 2.8 SELECTION OF OTHER MODES

All other functions that can be activated by remote control can also be activated locally. Each module has test switches to activate any such functions, such as RPTR ON and RPTR OFF. Most of these switches are momentary action, which causes the station to operate in the selected mode as long as the switch is held. The station will return to normal operation when the switch is released.

## 2.9 RECEIVED AUDIO

After the local speaker is turned on, or connected, the station is ready to receive audio. The receiver PL feature, if used, can be defeated by setting the station control module PL DISABLE switch in the direction of the arrow. (At the conclusion of local operation, be sure that the PL DISABLE switch is returned to its normal position.) If necessary, the receiver can be unscelched utilizing the receiver SQUELCH control on the receiver chassis. The VOLUME control on the receiver chassis sets the audio output level of the local speaker.

## 2.10 TRANSMITTING

### NOTE

Before initiating any local transmissions, monitor the channel to be sure that it is clear of other transmissions.

The transmitter is locally keyed by either activating the station control module XMIT switch or activating the push-to-talk microphone switch. Voice is transmitted using the local microphone.

## 2.11 CONCLUDING LOCAL OPERATION

At the conclusion of local operation, perform the following operations and checks to be sure that the station is ready for remote operation.

Step 1. Reset receiver squelch level per procedures in the Receiver Alignment section of this manual.

Step 2. Be sure that station control module switches are positioned for normal operation (reference Table 1).

- Step 3. Disconnect microphone and test speaker (if used).
- Step 4. Set all external power switches ON.
- Step 5. Be sure that station is operable from remote location.
- Step 6. Turn local speaker OFF (if applicable).
- Step 7. Disconnect or remove any metering plugs or test set.
- Step 8. Be sure that the cabinet door is locked.
- Step 9. Be sure that vents in cabinet are unobstructed.

**3. MAINTENANCE TECHNIQUES**

**3.1 GENERAL**

Specific maintenance procedures for individual chassis, which comprise this station, are contained in the latter paragraphs of this section. Control module maintenance information is provided in the separate Control and Audio manual 68P81061E40. As an aid to isolating a malfunction to a specific chassis or module, a variety of general techniques are appropriate. Refer to Table 2 for routine maintenance checklist.

**3.2 TRANSMITTER AND RECEIVER**

Most troubles in the transmitter or receiver can be quickly isolated with metering checks. A log of normal meter readings *for this station* should be maintained.

Each time maintenance is performed, the meter readings should be entered into the log. Variations from the previous readings can help to isolate a malfunction or may indicate an impending failure. If no previous meter readings are available, typical or minimum meter readings may be found in the receiver, exciter, and power amplifier sections as well as metering procedures.

**3.3 POWER SUPPLY**

A check of power supply voltages under load and no-load conditions (transmit and standby) should quickly isolate any malfunction.

**3.4 REMOTE CONTROL UNIT**

Isolation of a malfunction in the control portion of the rf control chassis requires a functional understanding of the overall station operation and the interrelationship between the various modules and chassis of the station. The Functional Description section along with the Control Modules section of manual 68P81061E40 provide necessary information. With a basic understanding of station operation, troubles may be isolated by analyzing the following questions:

- (1) Can the station be operated locally but not remotely? If so, this eliminates many circuits as possible sources of trouble.
- (2) How many modes are inoperable? Concentrate testing on circuits that are common to the inoperable modes.

*Table 2. Routine Maintenance Checklist*

| Item                         | Check  |
|------------------------------|--|
| Receiver                     | Measure the signal level required to obtain 20 dB quieting.  |
|                              | Compare meter readings with the minimum value and all previous readings taken. Realign the receiver, if necessary.                       |
|                              | For PL stations, check for proper operation of the PL decoder. Does the squelch open when the proper PL tone or binary code is detected? |
|                              | Verify receiver frequency, adjust if necessary.  |
| Transmitter                  | Measure transmitter output power.  |
|                              | Compare meter readings with the minimum value and all previous readings taken. Realign the transmitter, if necessary.                    |
|                              | Verify that each transmitter channel is on frequency and adjust if necessary.  |
|                              | Tune and load the transmitter to the antenna.  |
|                              | Measure transmitter frequency deviation for both voice and PL coded modulation. Adjust the "IDC" control, if necessary.                  |
|                              | Measure the exciter modulator sensitivity.   |
| System Operation             | Measure and adjust the audio input to the exciter.   |
|                              | Measure and adjust the receiver(s) audio output to the control line.   |
|                              | Check control line levels and functions for proper operation.  |
|                              | Adjust receiver(s) on frequency with the distant transmitter(s) in the system.   |
|                              | Check for proper repeater operation on repeater models.  |
|                              | Check all accessory equipment for proper operation.  |
| After Performing Maintenance | Check all items listed in the <i>Concluding Local Operation</i> paragraph of this section of the instruction manual.                     |

(3) Are adjustments properly set? This includes audio level adjustments at the station *and at the remote control point.*

(4) Are jumpers properly installed? The many jumpers in this station provide vast flexibility, but could be a source of trouble if improperly added, removed, or not removed, as the case may be.

#### 4. RECOMMENDED TEST EQUIPMENT

A list of recommended test equipment for maintenance of this station is given in Table 3.

### 5. DISASSEMBLY AND SERVICE ACCESS

#### 5.1 FRONT COVER AND LINE FUSE

**5.1.1** Access to all circuitry on the *MSR 2000* station is gained through the front of the station. To remove the front door, turn the lock to the left with the key provided with the station. Pull the door panel back, and lift it up slightly to disengage the mounting flanges at the bottom.

**5.1.2** The ac line fuse is located on the front side of the junction box at the right-hand side of the cabinet (refer to Figures 1 and 3). To replace the fuse, disconnect the

Table 3. Recommended Test Equipment

| Type of Equipment or Type of Measurement                                     | Equipment Characteristics   | Recommended Type  |
|--|---|---|
| Transmitter Frequency Measurement  | Frequency — 100-200 MHz<br>Accuracy — $\pm .00005\%$ or better  | Any of the following items of Motorola Test Equipment:<br>Model R2400 Series Service Monitor<br>Model R2001 Systems Analyzer<br>Model S1035 Series Frequency Counter  |
| Transmitter Deviation Measurement (Note 1)                                   | Peak reading type for voice or sinusoidal wave; scales for accurate reading of $\pm 5$ kHz deviation (and $\pm 1$ kHz deviation for <i>Private Line</i> models)           | Any of the following items of Motorola Test Equipment:<br>Model R2400 Series Service Monitor<br>Model S1035A Series Frequency Counter<br>Model R2001 Series System Analyzer   |
| Transmitter Power Output Measurement   | 100-200 MHz; 50 ohms: at least 0-125 watts.<br><br>50 ohms dummy load: at least 125 watts.  | Motorola S1350 Series Wattmeter with appropriate element<br>Motorola Model R2001 Series System Analyzer<br>Motorola Model T1013 Series RF Load Resistor   |
| RF Signal Generator for receiver testing (Note 2)                            | 100-200 MHz; FM; high-stability ( $\pm .0002\%$ or better); adjustable output 0 to 1000 microvolts  | Motorola Model R2400 Series Service Monitor<br>Motorola Model R2001 Series System Analyzer<br>Motorola Model R1040 Signal Generator   |
| Audio Voltage Measurements   | High impedance (10 megohm); dBm scale   | Motorola Model S1053 Series Solid State AC Voltmeter  |
| Audio Signal Generator for audio circuit testing in receiver and transmitter | Variable amplitude 0 to 1 volt; 1 kHz tone (300 to 3000 Hz preferred); sinusoidal wave  | Motorola Model S1150A Series Solid State Audio Oscillator<br>Motorola Model R2400 Series Service Monitor  |
| DC Voltage Measurements, Resistance Measurements, RF Voltage Measurements    | High impedance (11 megohm) DC multimeter  | Motorola Model R1047A Series Digital Multimeter<br>Motorola R1024 Solid State DC Multimeter with RTL4103 RF Probe   |
| Waveform Measurements  | Oscilloscope:   | Motorola Model R1029 Dual Trace Oscilloscope<br>Audio Circuit Measurements: Motorola Model R1004 Series Oscilloscope<br>RF Circuit Measurements: A very high quality instrument is required (at least 50 MHz bandwidth) |
| Tone <i>Private-Line</i> injection for PL decoder circuit measurements       | <i>Private-Line</i> tone generator using Vibrasender resonant reed for frequency accuracy; or audio oscillator with frequency counter for accurate setting of oscillator. | Motorola Model R1150A Series <i>Private-Line</i> Tone Generator   |
| Digital <i>Private-Line</i> Encoder and Decoder measurements                 | Digital <i>Private-Line</i> Encoder and Decoder. Also test digital code plugs.  | Motorola Model R1150A Series Code Synthesizer   |
| Tuning Tool  | Used for adjusting all tunable components during equipment alignment.   | Motorola Part No. 66-83398A01 & 66-82977K01   |
| Contact Removal Tool   | Used to remove female wire terminals from metering cable connector  | Motorola Part No. 66-84690C01   |

line cord from the junction box. Unscrew the fuseholder cover from the fuseholder with a screwdriver.

## 5.2 POWER AMPLIFIER ACCESS AND REMOVAL

### 5.2.1 Access to Intermittent Duty Power Amplifier

**5.2.1.1** To gain access to the power control board for servicing and metering, remove the 5 screws holding the cover over the power control board area of the PA casting (refer to Figure 1).

**5.2.1.2** To gain access to the power amplifier board for servicing, remove the two black power amplifier securing screws. Swing the PA chassis assembly out and down (it is hinged at the bottom). Loosen 4 captive screws holding the cover over the power amplifier board (refer to Figure 2).

### 5.2.2 Access to Continuous Duty Power Amplifier

**5.2.2.1** To gain access to the power amplifier boards for servicing and metering, remove the 4 black power amplifier securing screws. Swing the PA chassis assembly out and down (it is hinged at the bottom). Metering is accessible without removing any covers. Remove 12 screws holding the cover over the PA and power control board for servicing the PA (refer to Figures 3 and 4).

**5.2.2.2** To gain access to the power control board for servicing, remove the 4 screws holding the power control bracket (refer to Figure 4).

### 5.2.3 Removal of Power Amplifier

The entire power amplifier chassis may be removed, if desired, for substitution or for access to the power supply. Perform the following steps:

Step 1. Disconnect the two coaxial connectors from J802 and J803 on the PA chassis. Disconnect the two power wires (red and black) from TB601 at the power supply.

Step 2. Swing the power amplifier chassis into the down position as explained above. Disconnect P801, the three-wire connector, from J801 on the PA chassis.

Step 3. With both hands under the PA chassis, lift the chassis approximately 1/2-inch and pull it toward you. Raise the left side of the PA chassis until the hinge pins clear the mounting rails, and pull the PA chassis out of the station cabinet.

Step 4. Installation is the reverse of the above.

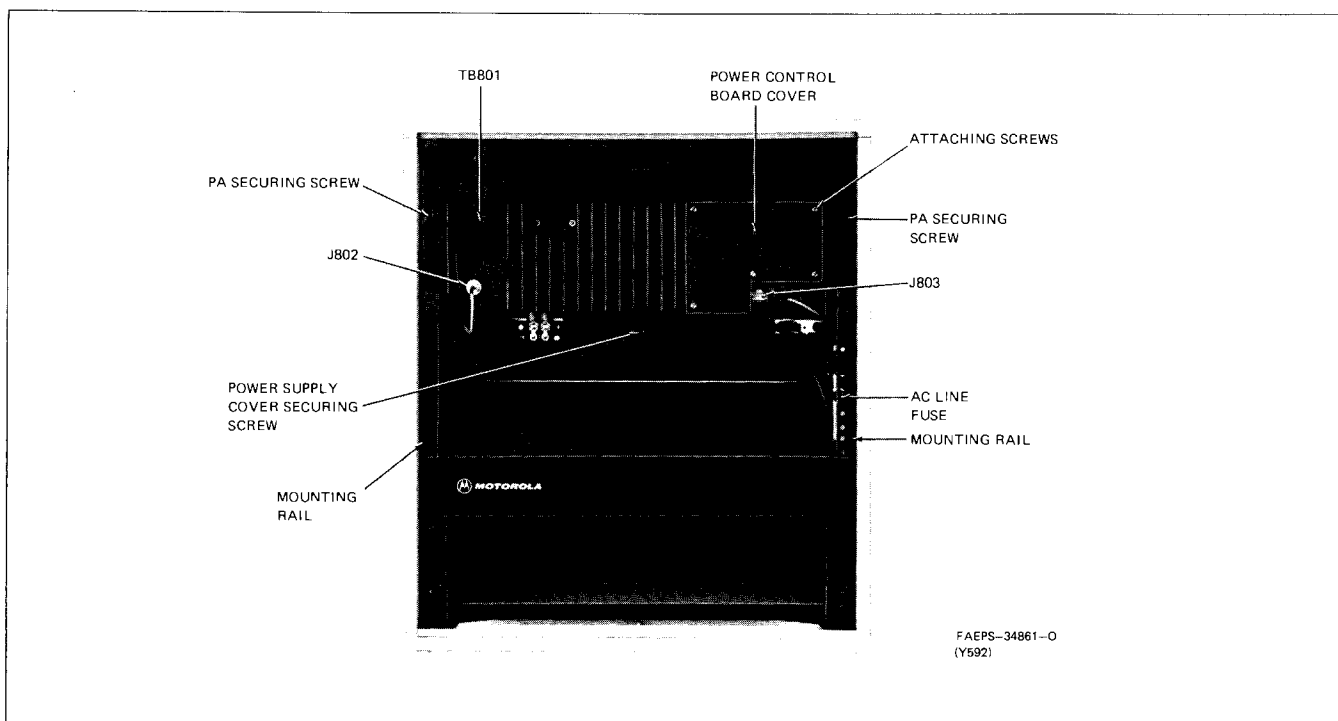

Figure 1. PA and Power Supply Detail of Intermittent Duty Station

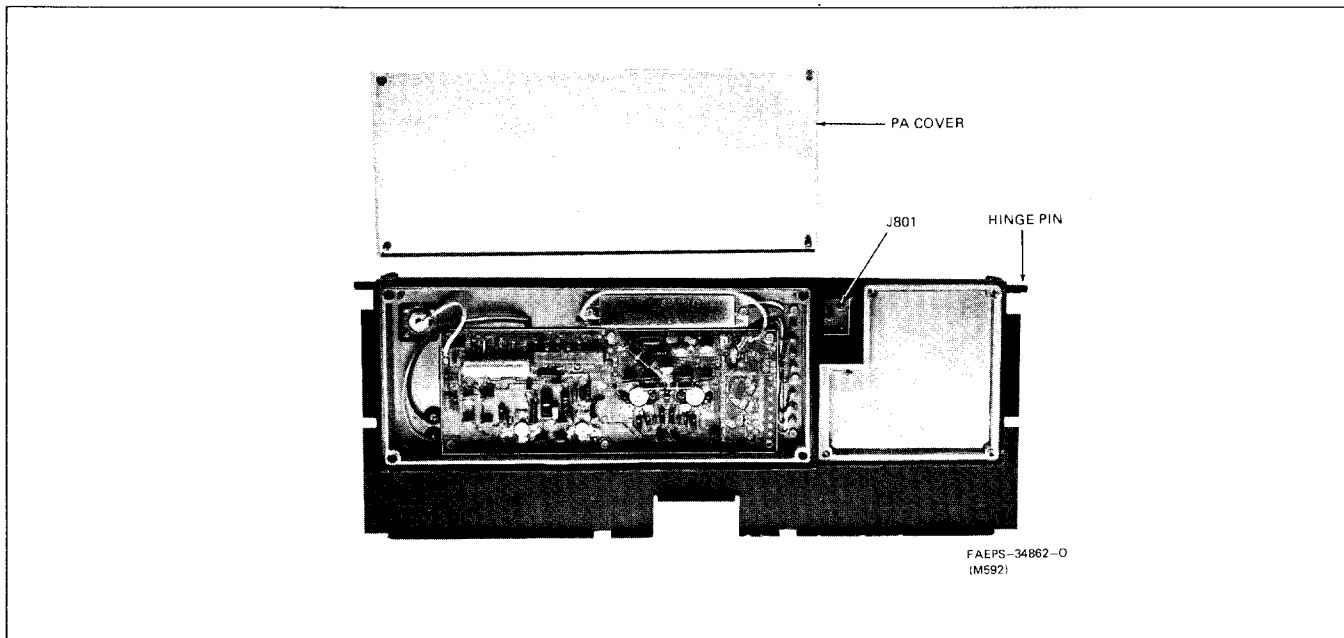

Figure 2. Power Amplifier Detail of Intermittent Duty Station

### 5.3 RF CONTROL CHASSIS ACCESS AND REMOVAL

(Refer to Figures 1 and 3.)

**5.3.1** The rf control chassis may be opened or lowered for service access. The control module cover panel must be removed for access to control and audio modules, and the chassis may be tilted out for access to the back of the backplane interconnect board and the rf boards.

**5.3.2** To remove the control module cover panel, pull outward on the lip at the top of the panel. The panel snaps and pivots outward. The control and audio modules may be removed for servicing with a Motorola part no. 66-83574F01 Card Puller, supplied with the station.

**5.3.3** To tilt out the rf control chassis, remove two black Phillips head screws securing the rf control chassis in place. Pull the chassis out from the top and tilt downward. In this position, all exciter and receiver metering connections are accessible, and the backplane interconnect board may be serviced.

**5.3.4** To remove the rf control chassis, tilt out the chassis to the service position and perform the following steps:

Step 1. Mark and disconnect all wiring from the terminal screws on the backplane interconnect board.

Step 2. Remove two screws securing each rf coaxial connector to the exciter and receiver positions.

Step 3. Disconnect main wiring harness connector P1 from J1 on the backplane interconnect board.

Step 4. Cut all wire ties and remove any cable clamps securing cables to the rf control chassis.

Step 5. Lift up the rf control chassis approximately 1/2 inch and pull toward you. Raise the left-hand end of the chassis until the hinge pins clear the mounting rails, and pull the chassis out of the station housing.

Step 6. Installation is the reverse of the above. Be sure to replace all wire ties and cable clamps in the position originally supplied.

### 5.4 EXCITER AND RECEIVER ACCESS AND REMOVAL

#### 5.4.1 RF Cover — Base Station Models

To remove the rf cover to gain access to the exciter and receiver circuit boards, remove 4 Phillips head screws (with plastic covers) as shown in Figure 5. Slide the cover out slightly and lift up while pulling toward you. Pull the cover out of the station cabinet. Tilt out the rf control chassis as explained in paragraph 5.3 for easy access to the exciter and receiver circuit boards. The exciter and receiver circuit boards may be removed by

pulling the ejector handles and then pulling the boards out of the chassis.

**5.4.2 RF Covers — Fully Optionable Repeater Station Models or Stations with Shield Option**

**5.4.2.1** To remove the front rf cover, remove 4 Phillips head screws (with plastic covers) as shown in Figures 6 and 7. The exciter and receiver boards may now be removed by pulling the ejector handles and then pulling the boards out of the chassis.

**5.4.2.2** To remove the top rf cover (front rf cover must be removed first), remove two black Phillips head screws securing the rf control chassis in place. Tilt the chassis out from the top by pulling toward you. Loosen 15 hex-head screws holding the cover in place, and slide the cover down so that the large end of the keyhole slots clear the securing screws. Lift the panel away from the chassis.

**5.5 SPEAKER INTERCOM WITH SPEAKER AND DC METERING CHASSIS ACCESS**

Instructions for use of the station service accessory boxes are given in the Accessories section of this man-

ual. For ease in servicing, the box may be removed from the station cabinet.

**5.6 DUPLEXER REMOVAL**

Instructions for servicing and adjusting the duplexer are provided in the Duplexer instruction section in this manual. To remove the duplexer from the *MSR 2000* station cabinet, remove four black Phillips-head screws securing the duplexer to the mounting rails. Pull the duplexer partially out of the cabinet, until the rf connectors are accessible. Disconnect three UHF-type connectors, and remove the duplexer from the station cabinet. Installation is the reverse of this procedure.

**5.7 POWER SUPPLY ACCESS**

**5.7.1** The power supply may usually be serviced without removing it from the cabinet. If removal is necessary, refer to the Power Supply instruction section of this manual for the recommended removal procedure.

**5.7.2** To gain access to the power supply chassis, remove the power supply cover plate located under the PA chassis. It is retained by a single screw in the upper center of the cover (refer to Figures 1 and 3). For continuous duty stations, remove the top power supply cover plate located directly behind the PA chassis. It is re-

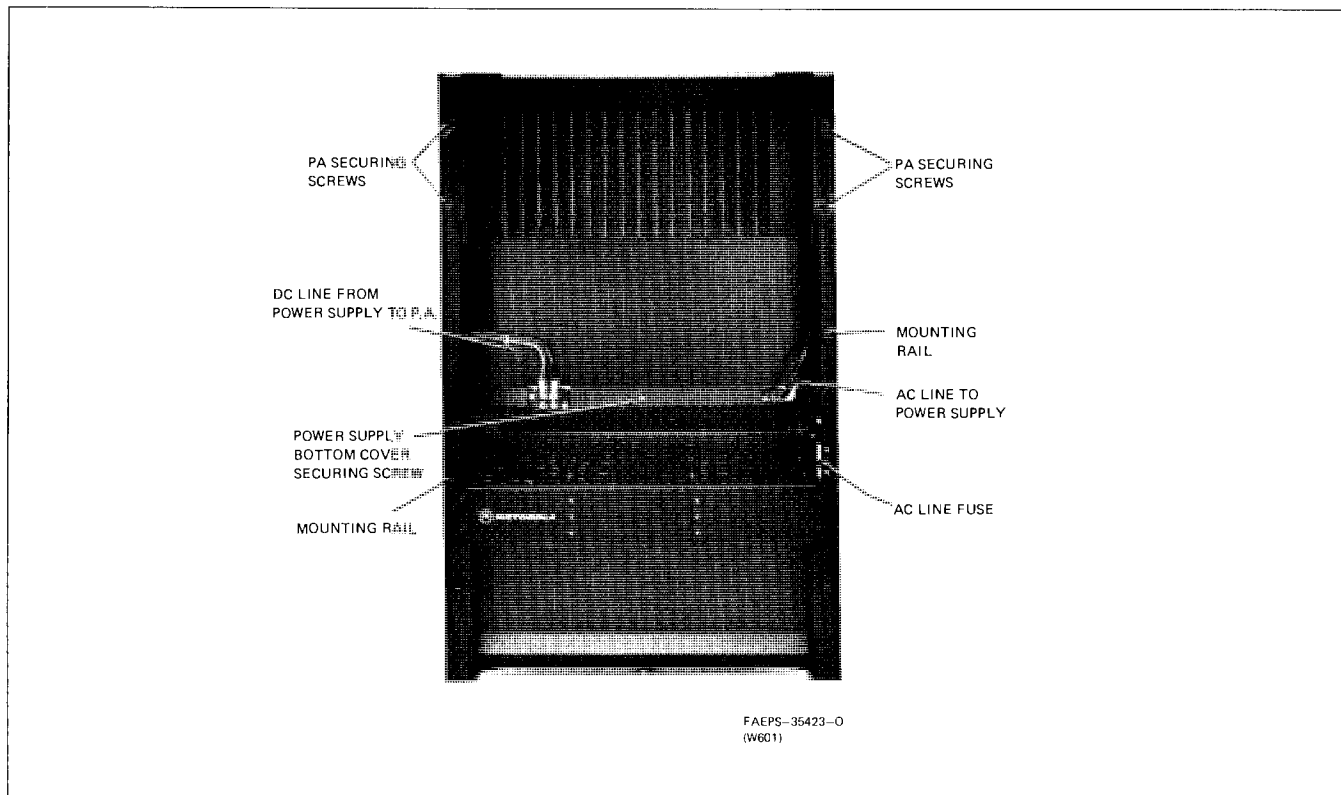

Figure 3. PA and Power Supply Detail of Continuous Duty Station

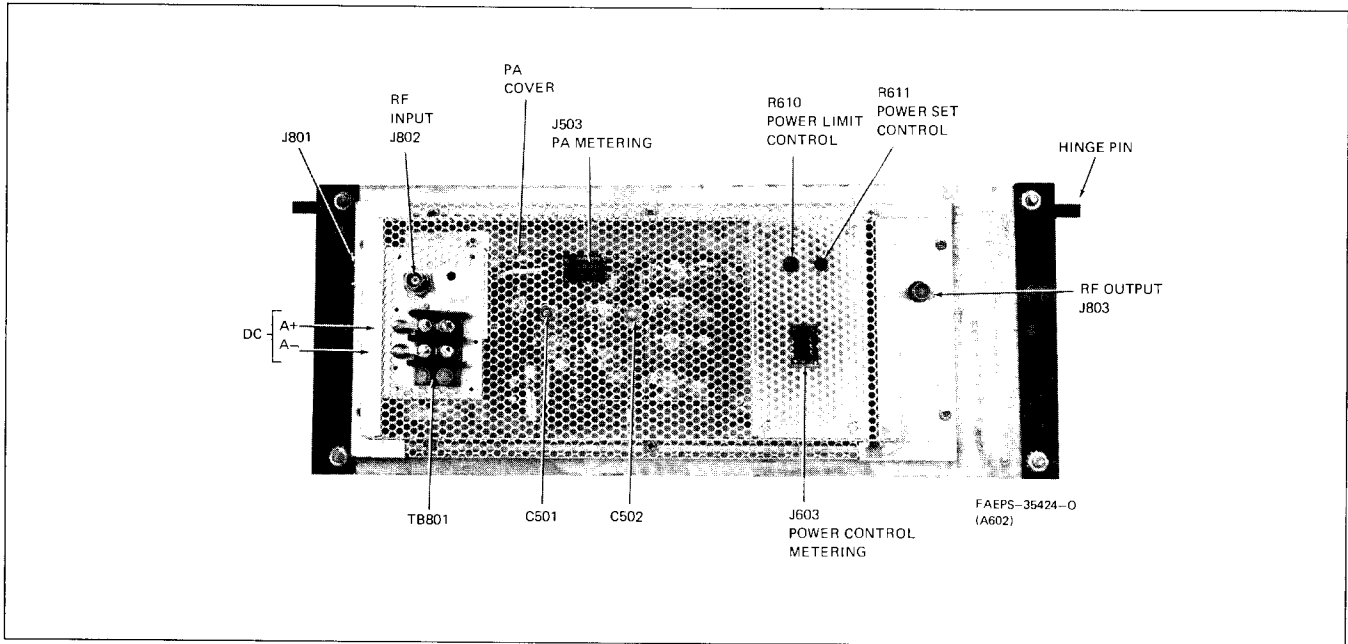

Figure 4. Power Amplifier Detail of Continuous Duty Station

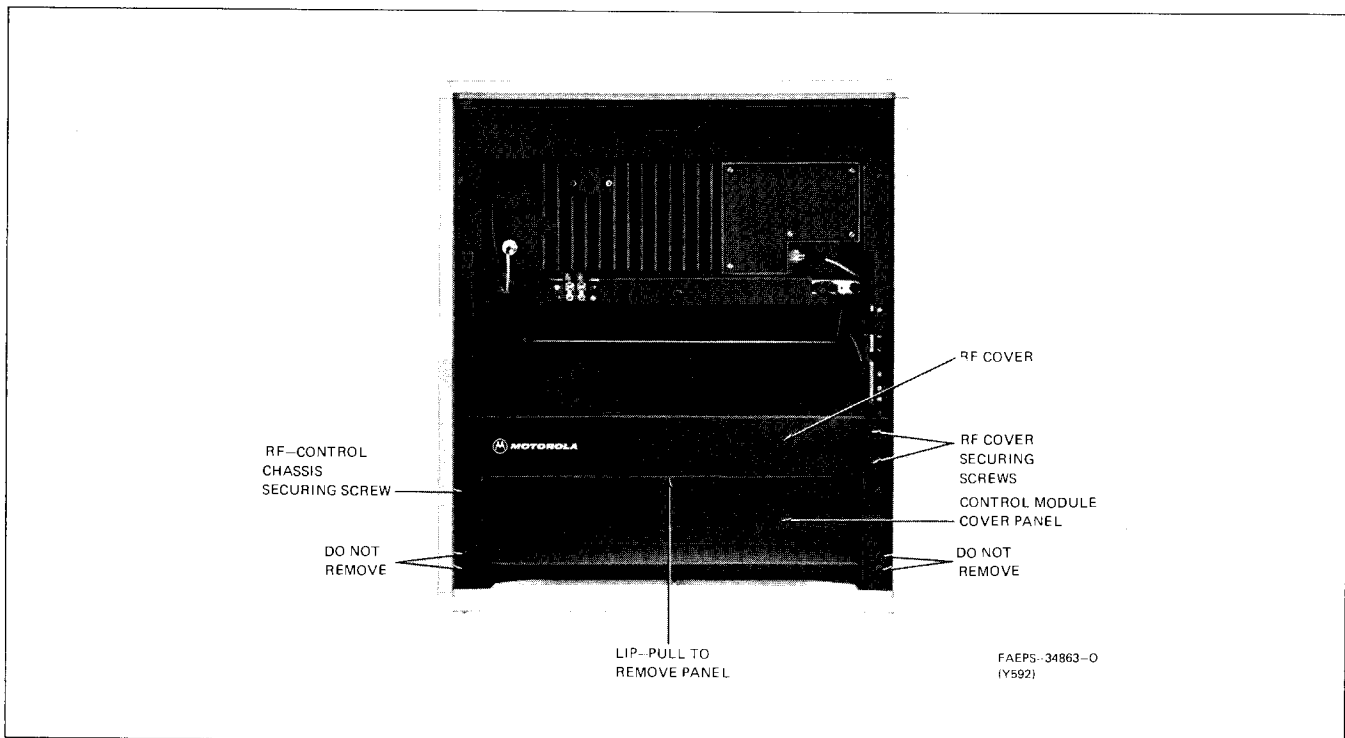

Figure 5. Basic Intermittent Duty Station Chassis Access

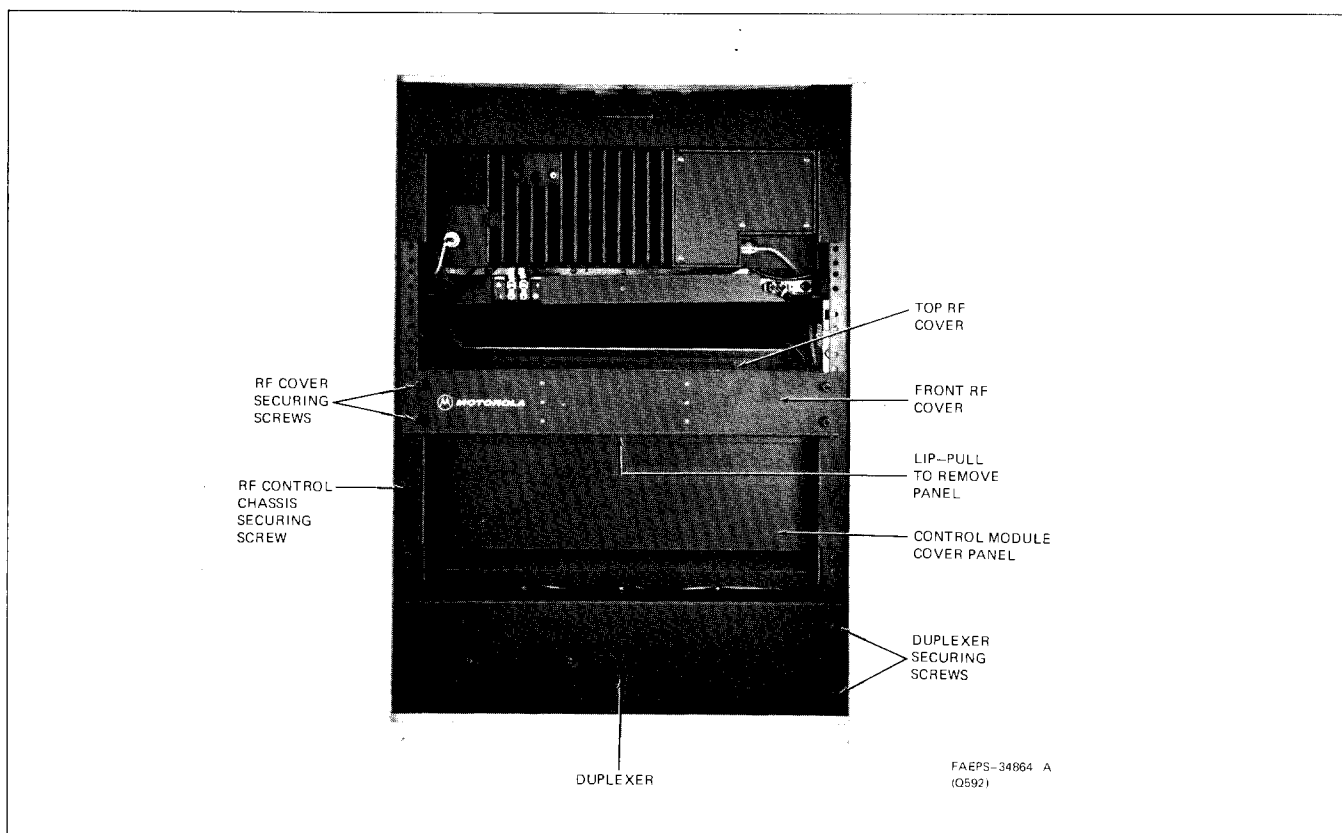

Figure 6. Fully Optionable Intermittent Duty Station Chassis Access

tained by two screws located in the lower left and right hand corners. It may also be necessary to remove the PA chassis from the station housing, refer to the Power Amplifier Removal and Access paragraph in this section.

### 5.8 TWO-RECEIVER COUPLER REMOVAL

The two-receiver coupler is located along the left-hand side of the station housing, and is accessible only with the rf control chassis removed from the station housing. Refer to the RF Control Chassis Access and Removal paragraph for the correct procedure. To remove the two-receiver coupler from the station housing, remove 2 screws securing it to the mounting rails. Lift the two-receiver coupler away from the mounting rails and disconnect the 3 phono-type rf connectors from the coupler plate.

### 5.9 JUNCTION BOX ACCESS

The back side of the junction box (TRN5350A or TRN5351A) can be reached by removing only the locking station cover. The line cord connection panel may be removed from the outside of the station housing by removing 2 screws holding the panel in place. To remove the entire junction box assembly from the station, remove the station wraparound cover following the procedure in the Wraparound Cover Removal paragraph. Remove 4 screws holding the junction box to the mounting rails.

### 5.10 WRAPAROUND COVER REMOVAL

The station wraparound cover is secured in place by the top and bottom covers of the station. To remove the station wraparound cover, perform the following steps:

Step 1. Remove six TORX®-type (T45) screws holding the top cover in place, using a Motorola part number 66-84071N02 TORX® wrench.

Step 2. Lift the wraparound cover approximately 1/2-inch up and out of the bottom cover channel.

Step 3. Spread the sides of the wraparound cover enough to clear the mounting rails of the station housing, and slide the housing toward the back of the station and remove.

Step 4. Installation is the reverse of the above.

## 6. MECHANICAL PARTS IDENTIFICATION

The mechanical parts identification photos are used to identify certain mechanical parts that are not identified elsewhere in the manual.



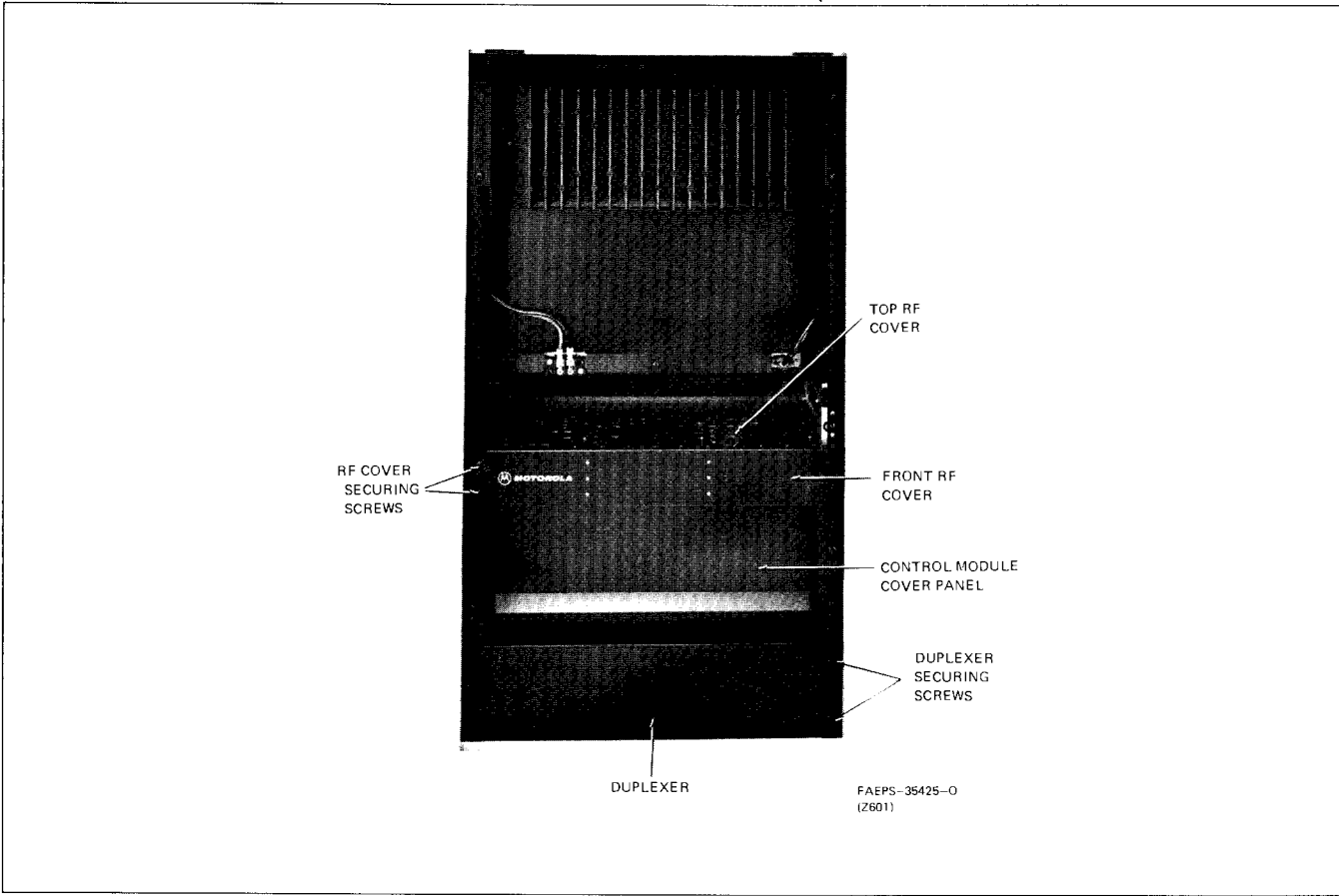

*Figure 7. Fully Optionable Continuous Duty Station Chassis Access*

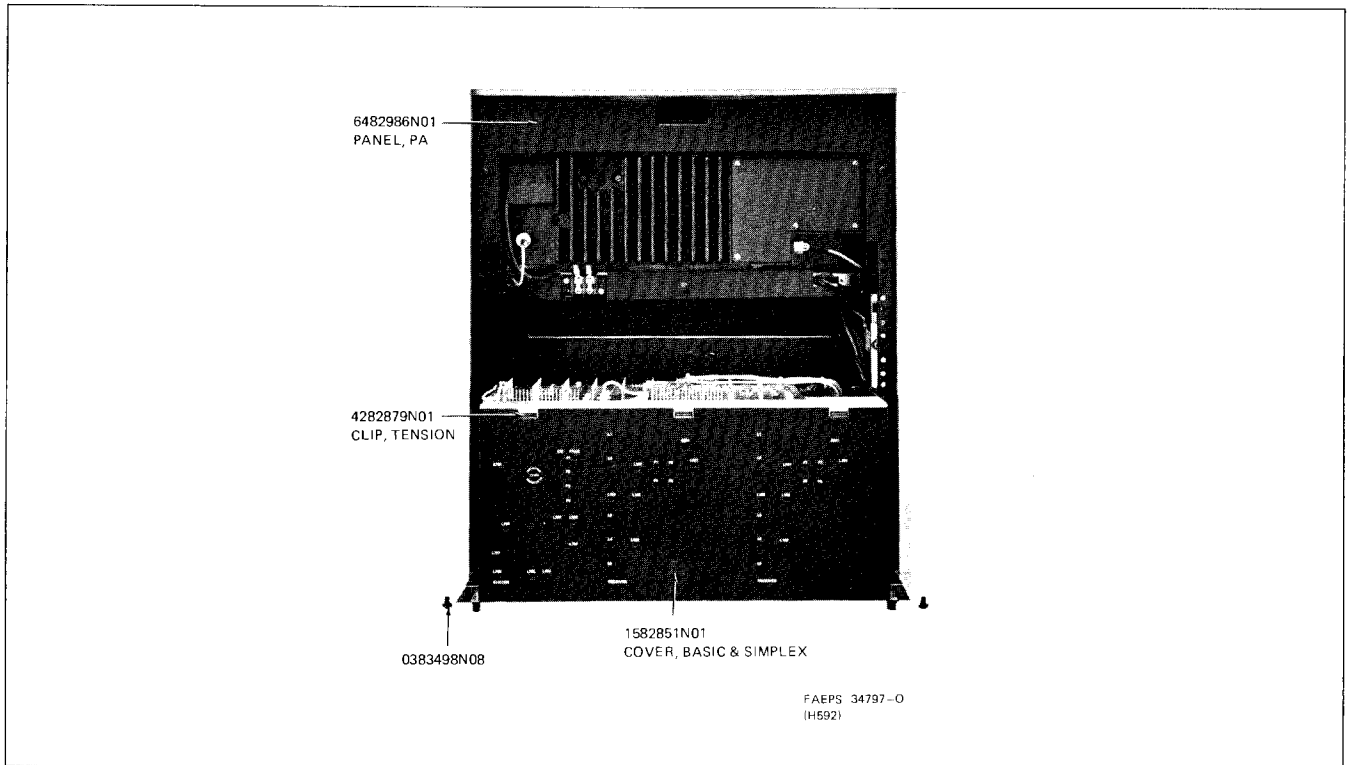
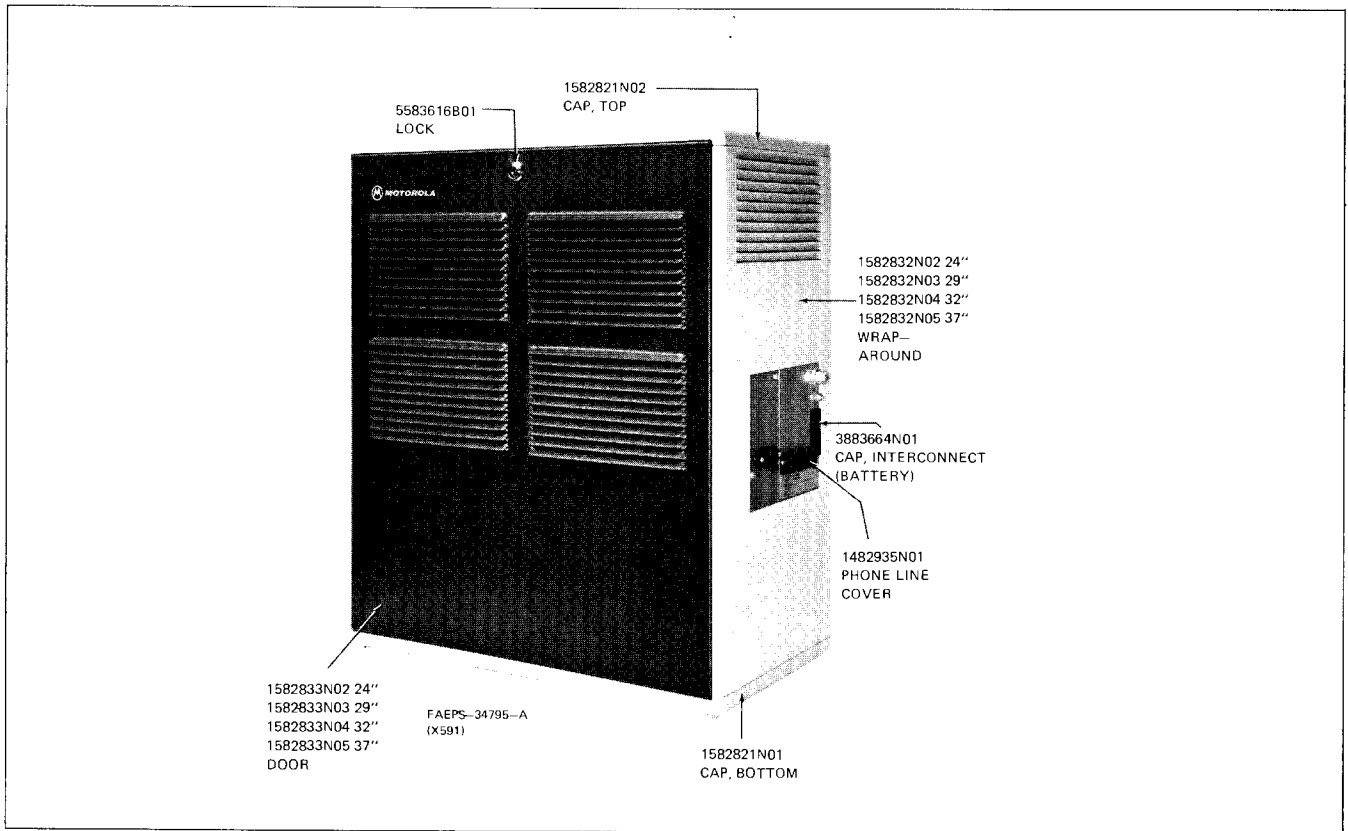

Figure 8. MSR 2000 Basic Model Station Mechanical Parts Identification

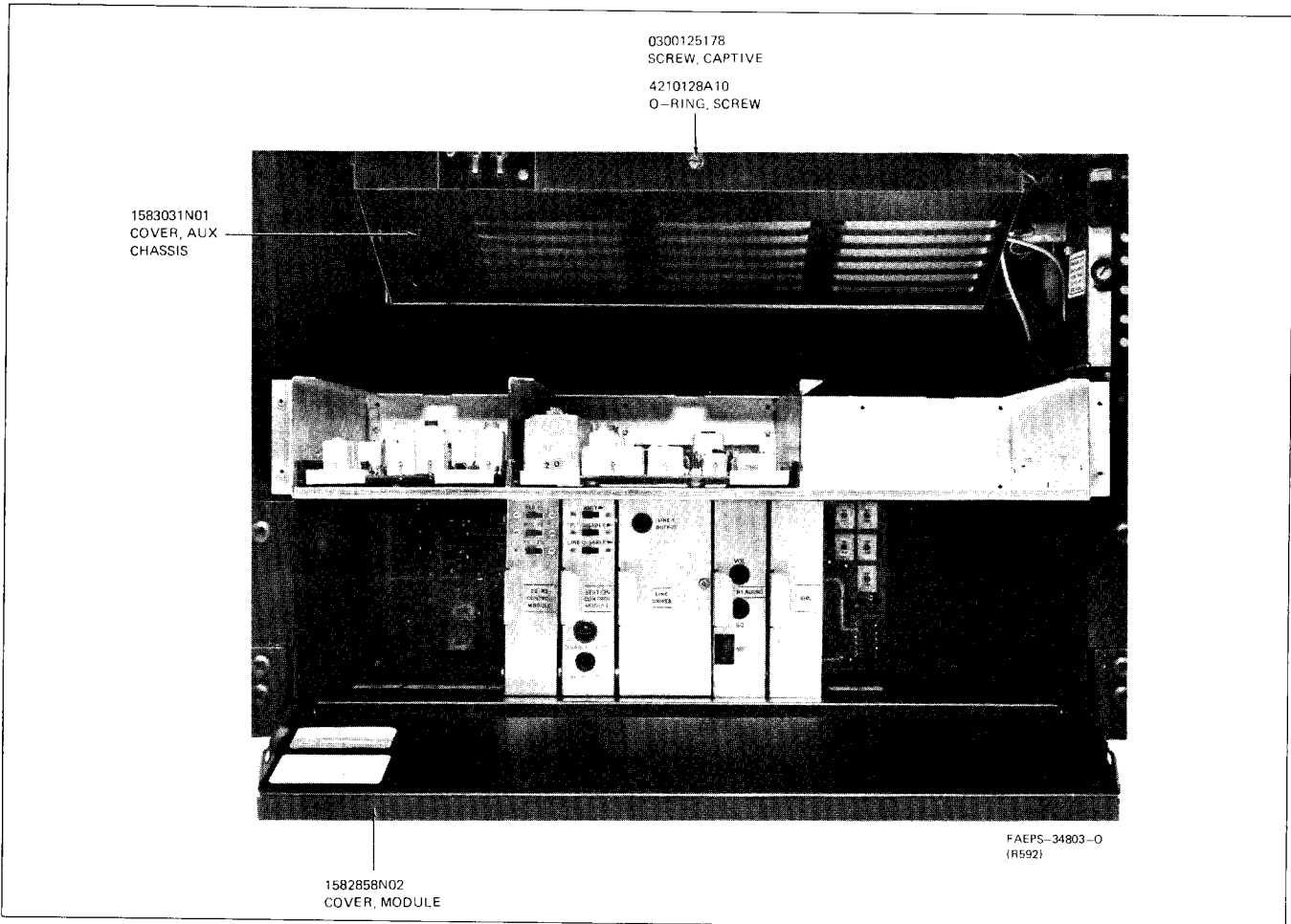
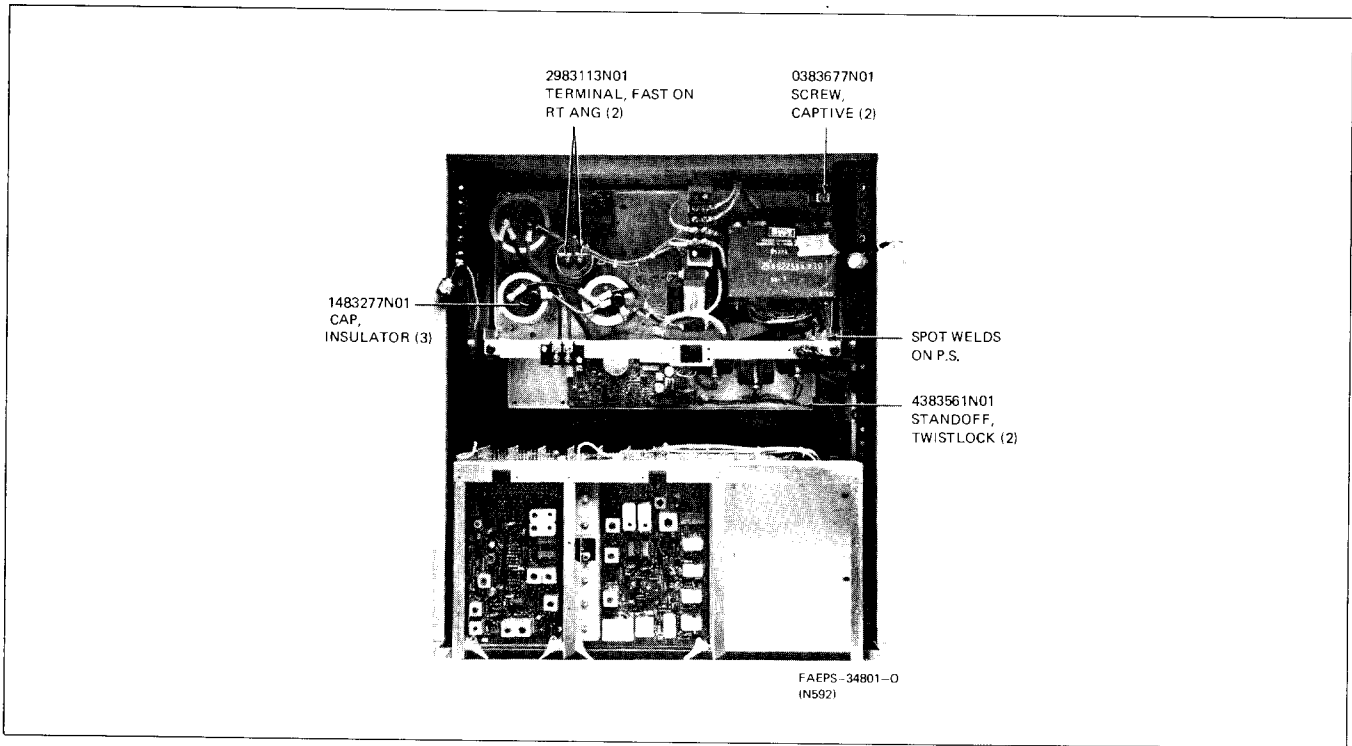

Figure 9. MSR 2000 Basic Model Station Mechanical Parts Identification

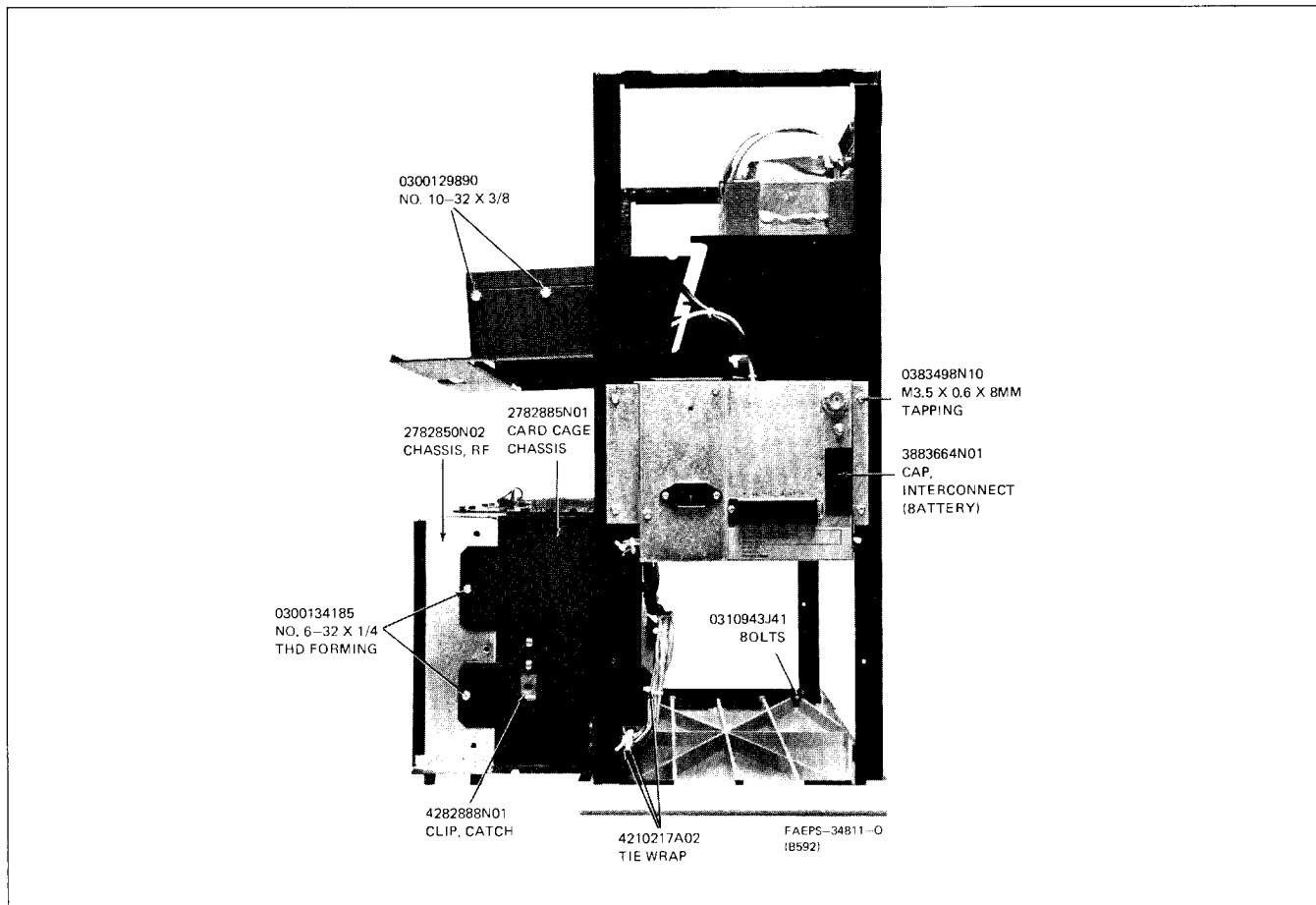
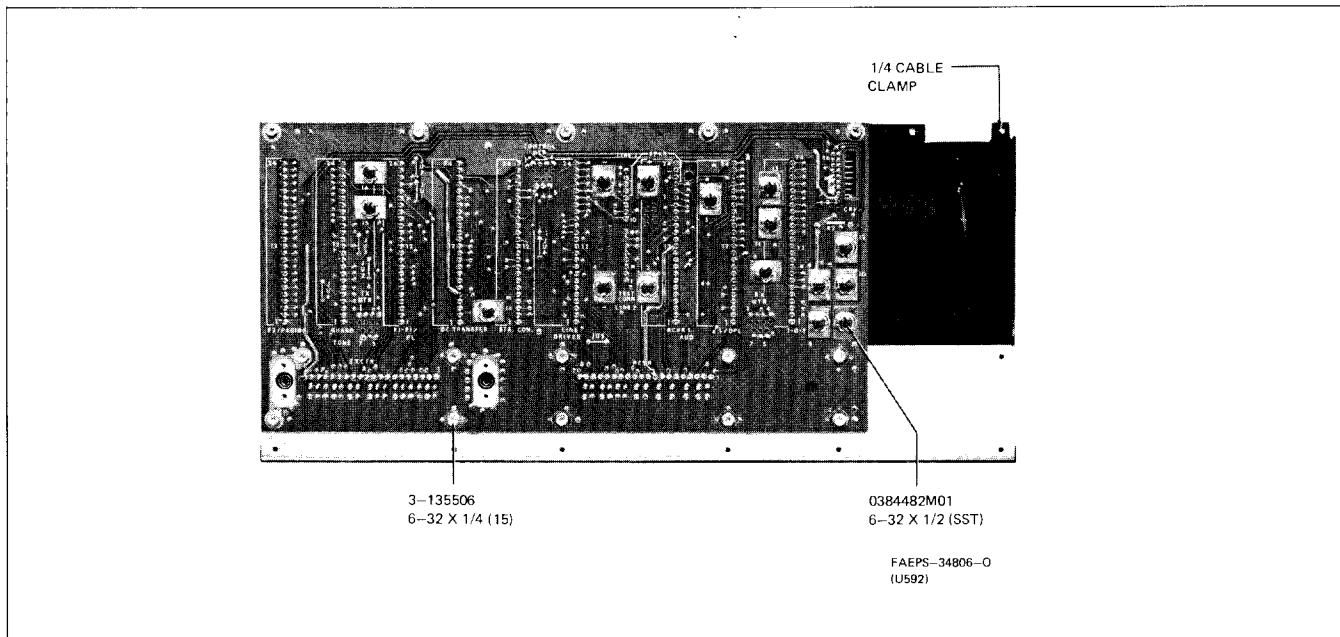

Figure 10. MSR 2000 Basic Model Station Mechanical Parts Identification

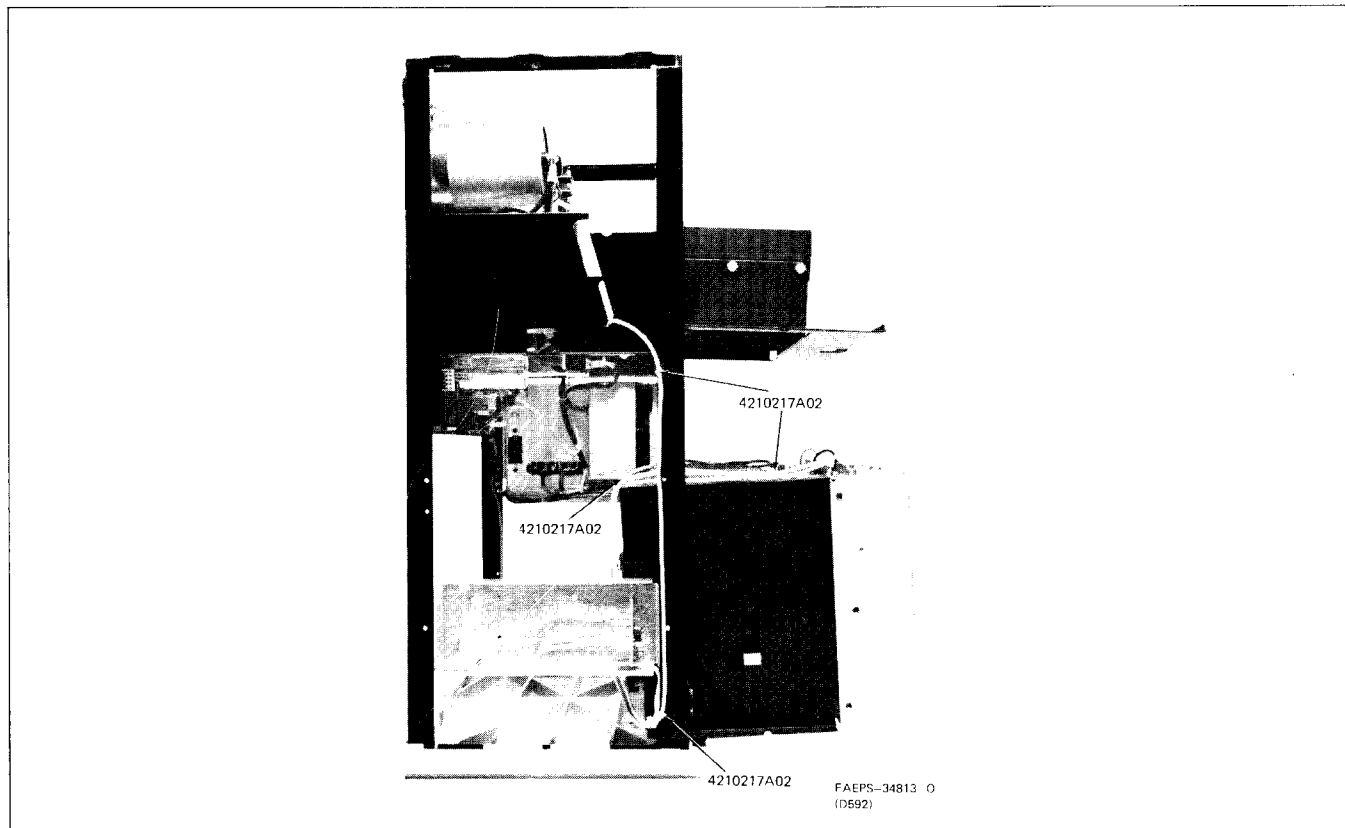
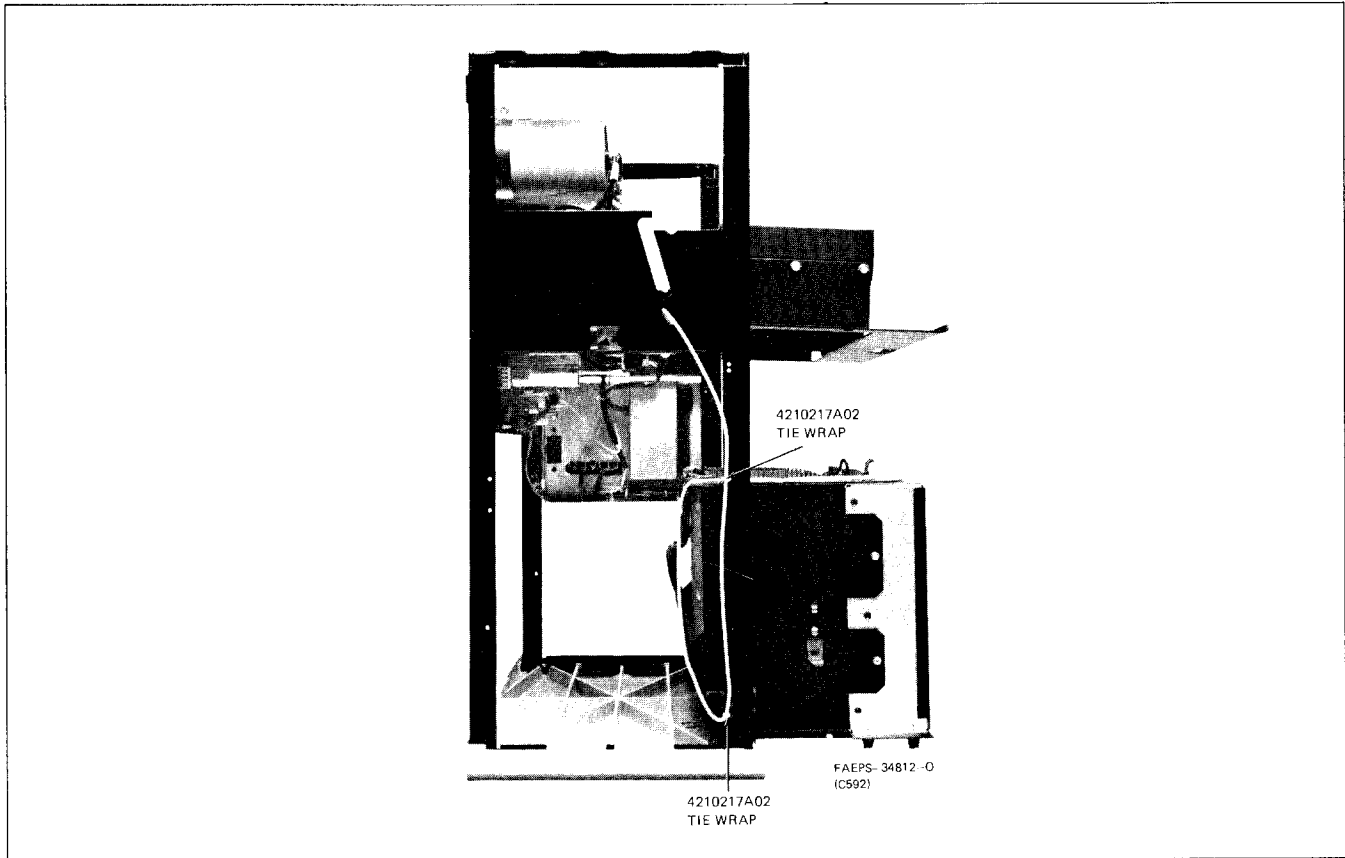

Figure 11. MSR 2000 Basic Model Station Mechanical Parts Identification

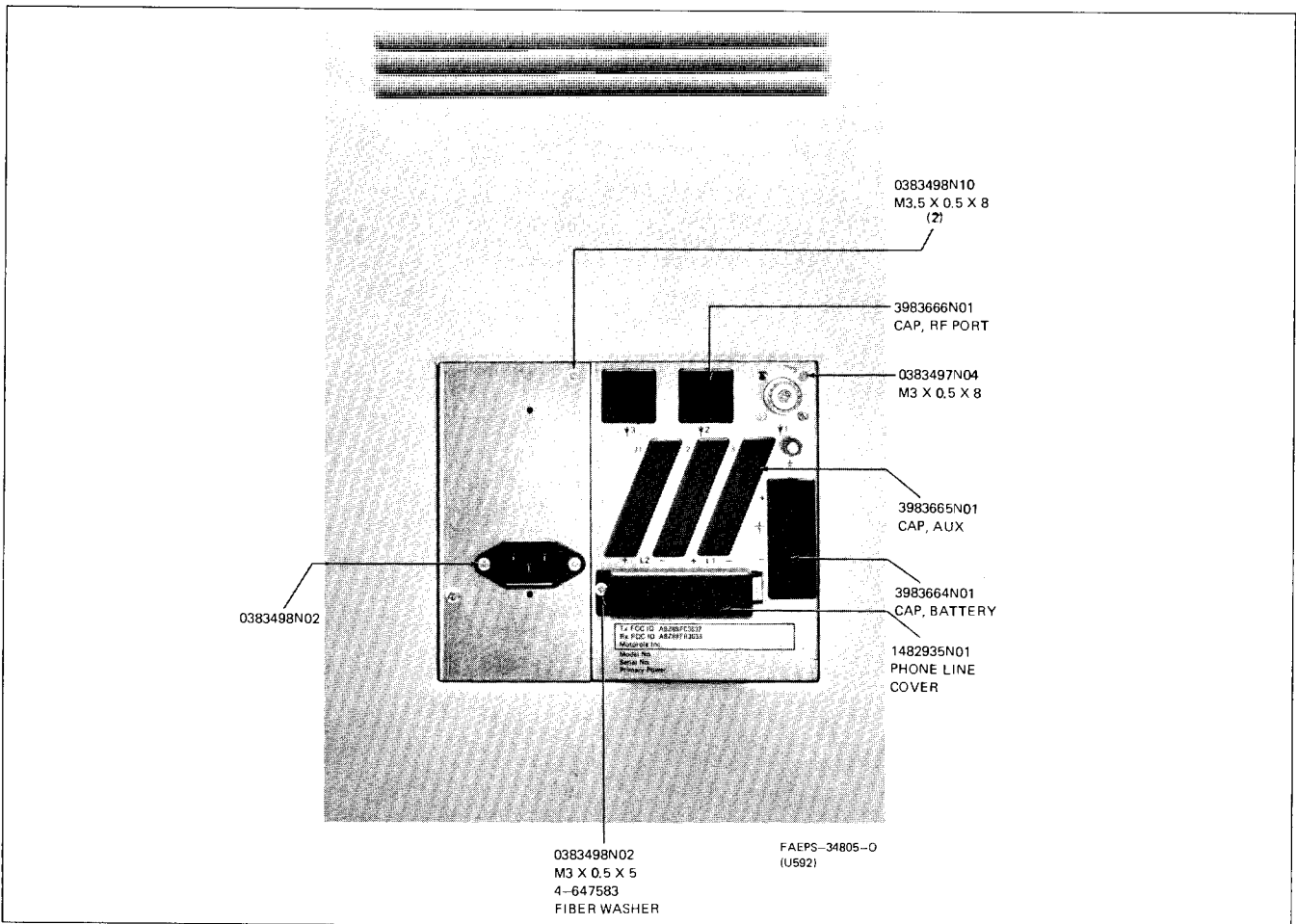
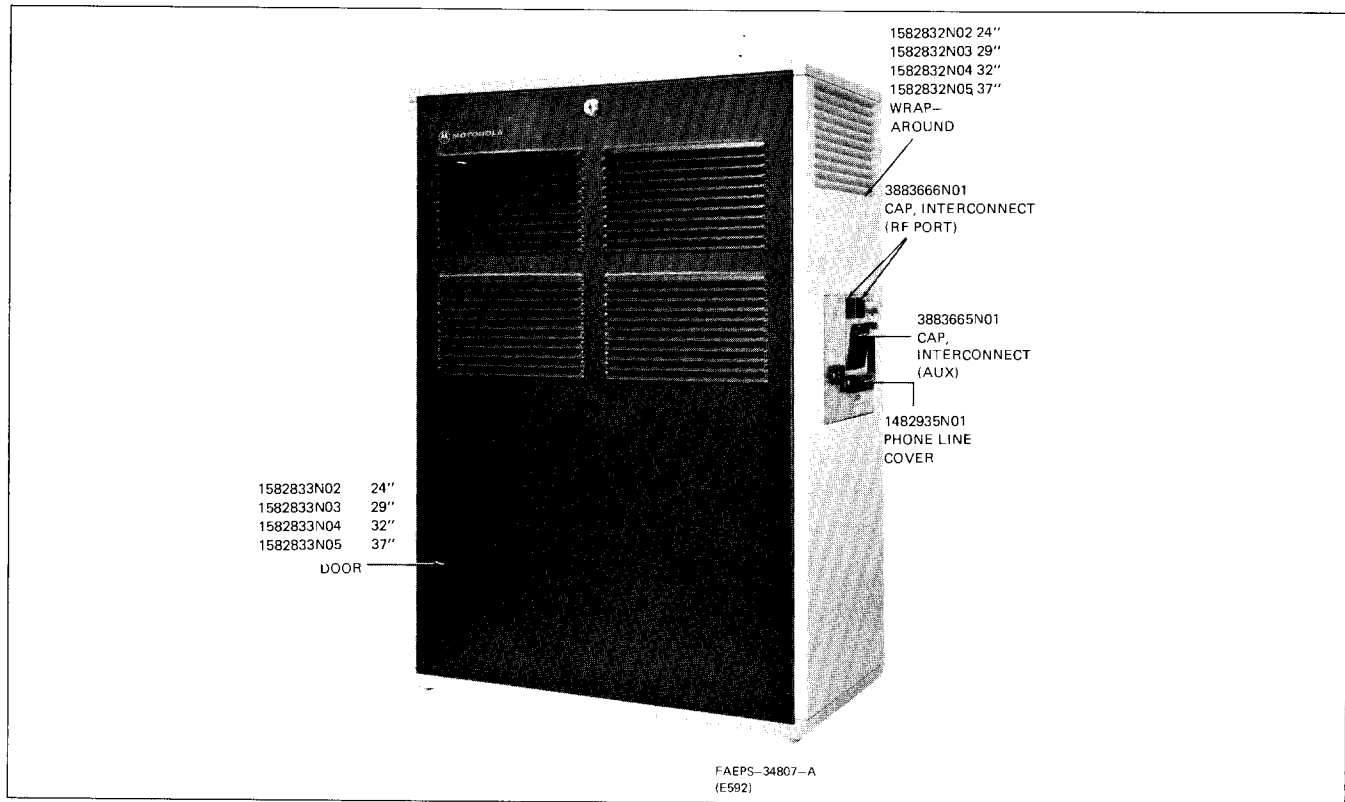

Figure 12. MSR 2000 Fully Optionable Model Station Mechanical Parts Identification

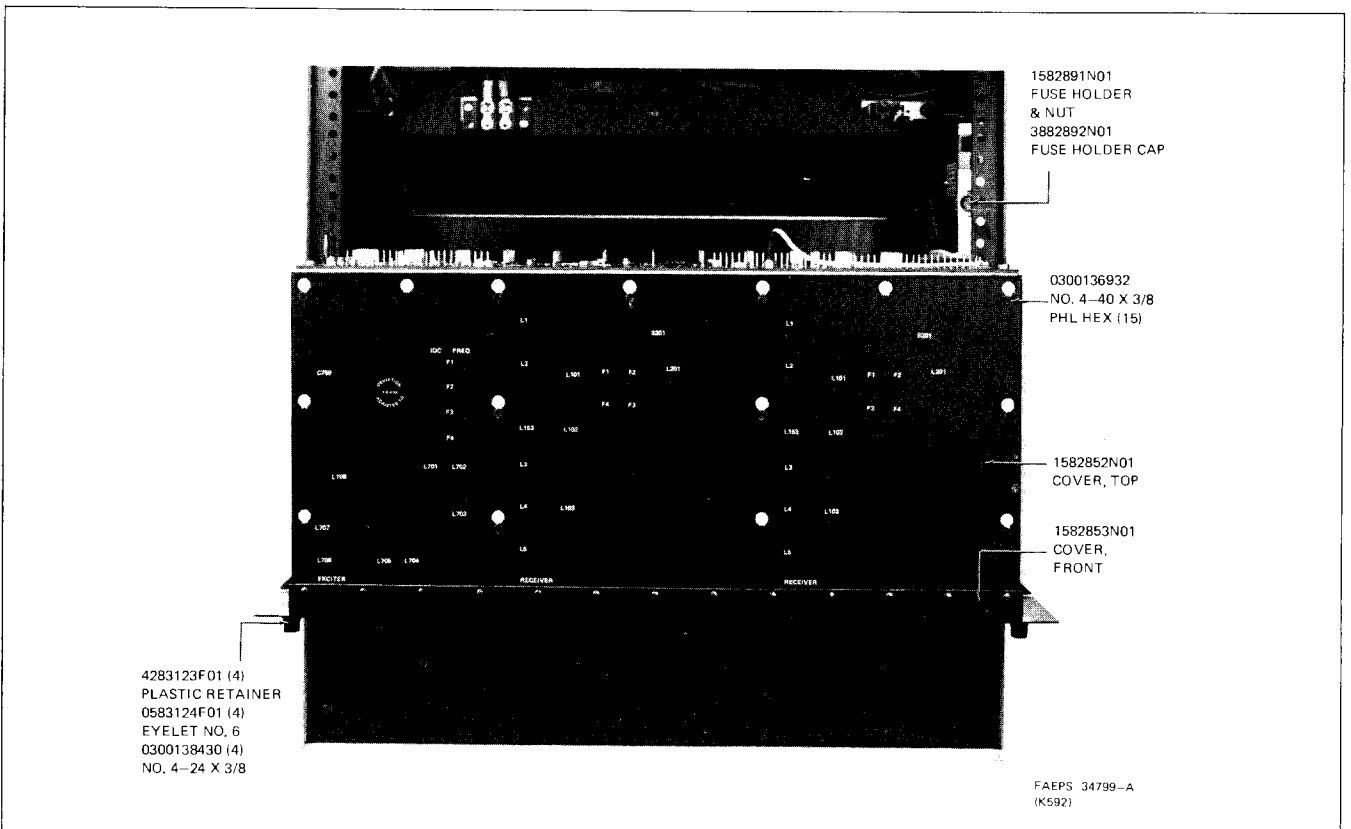
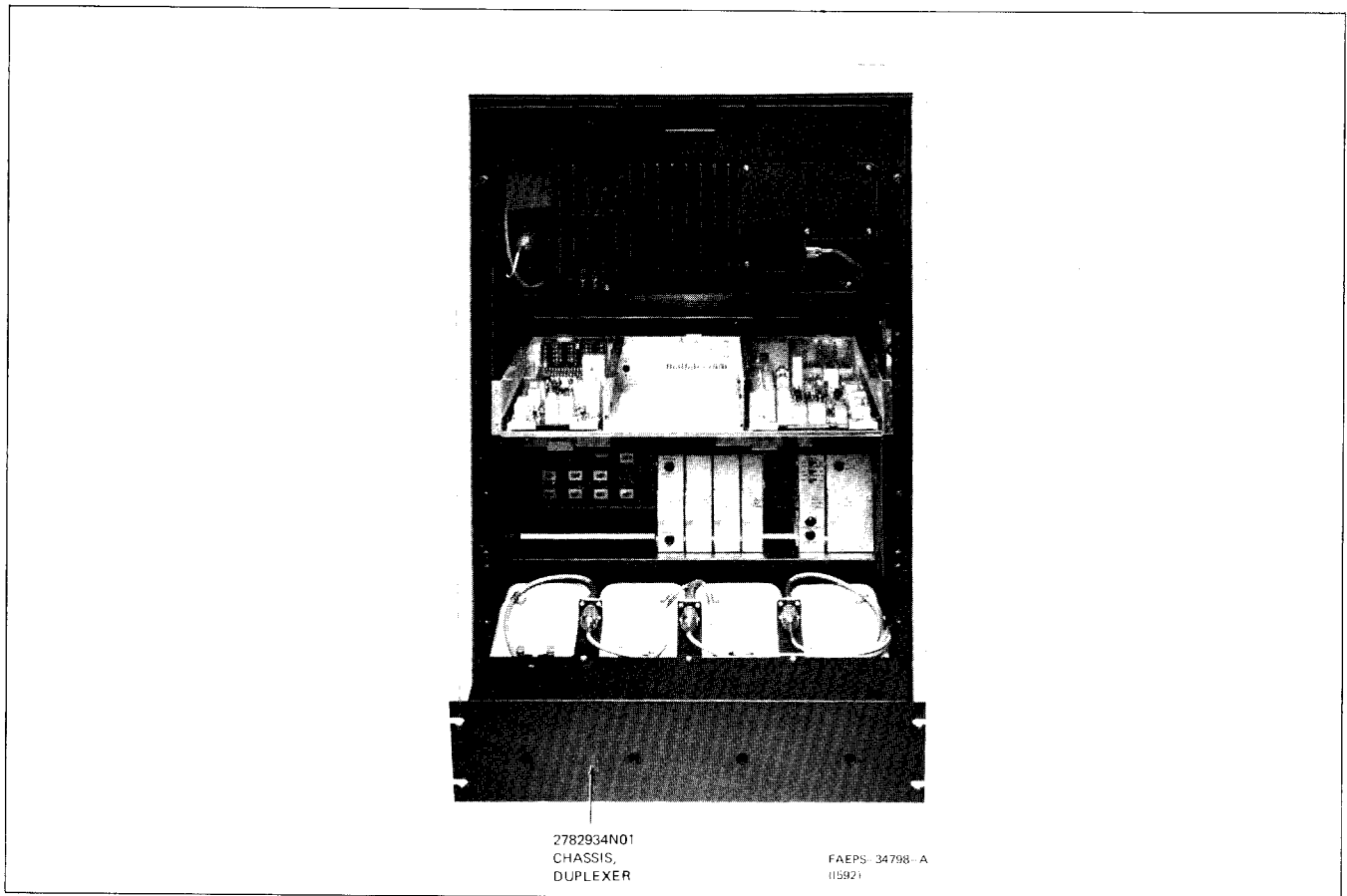

Figure 13. MSR 2000 Fully Optionable Model Station Mechanical Parts Identification

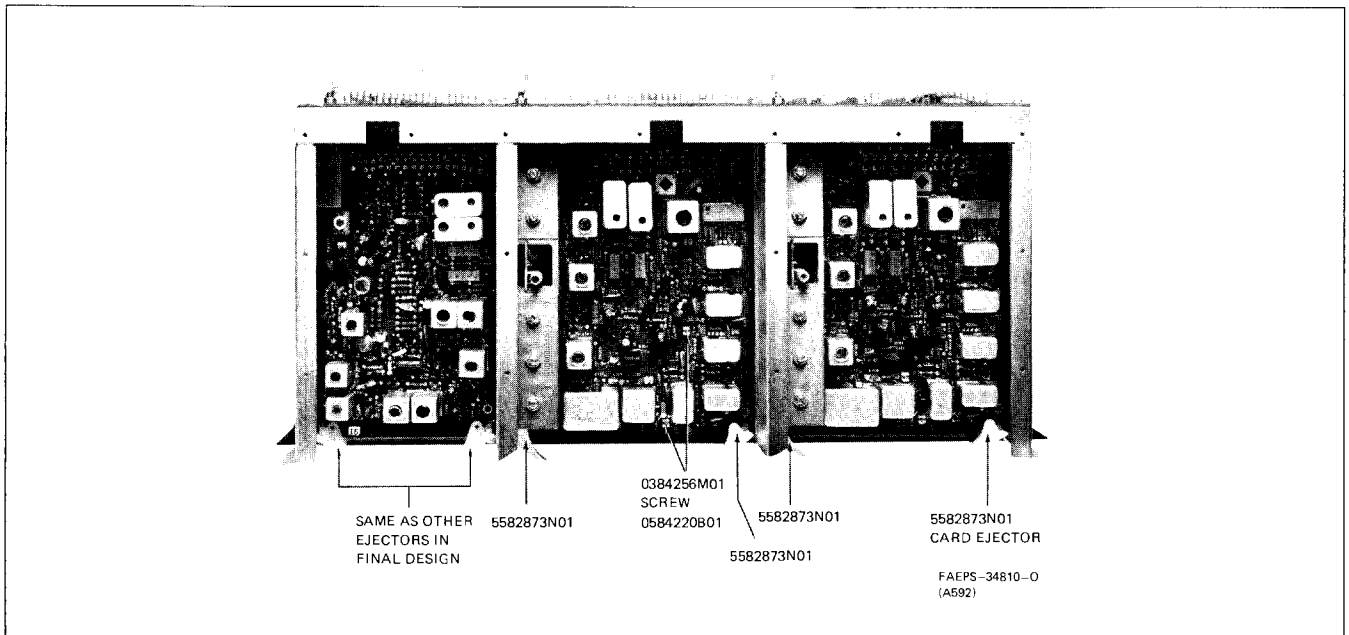
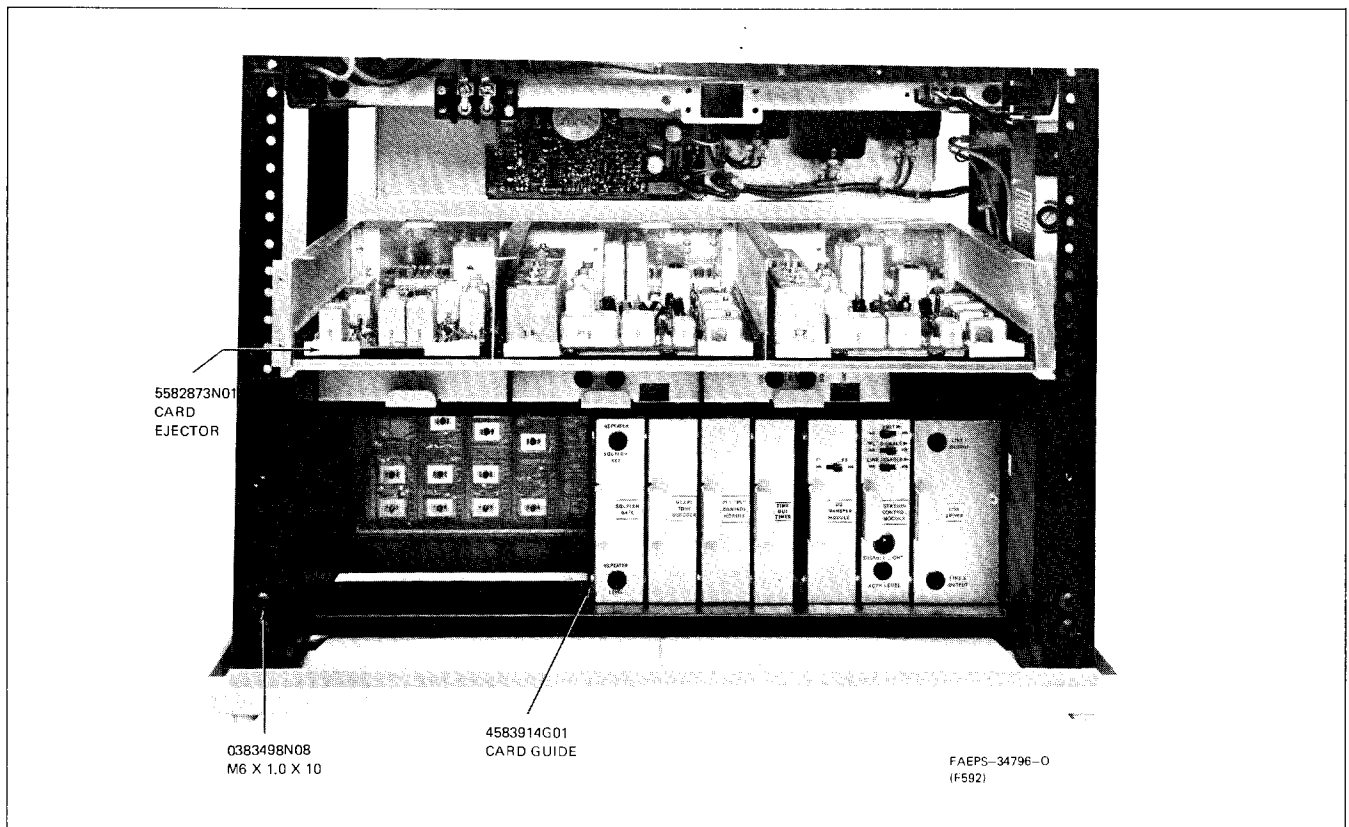
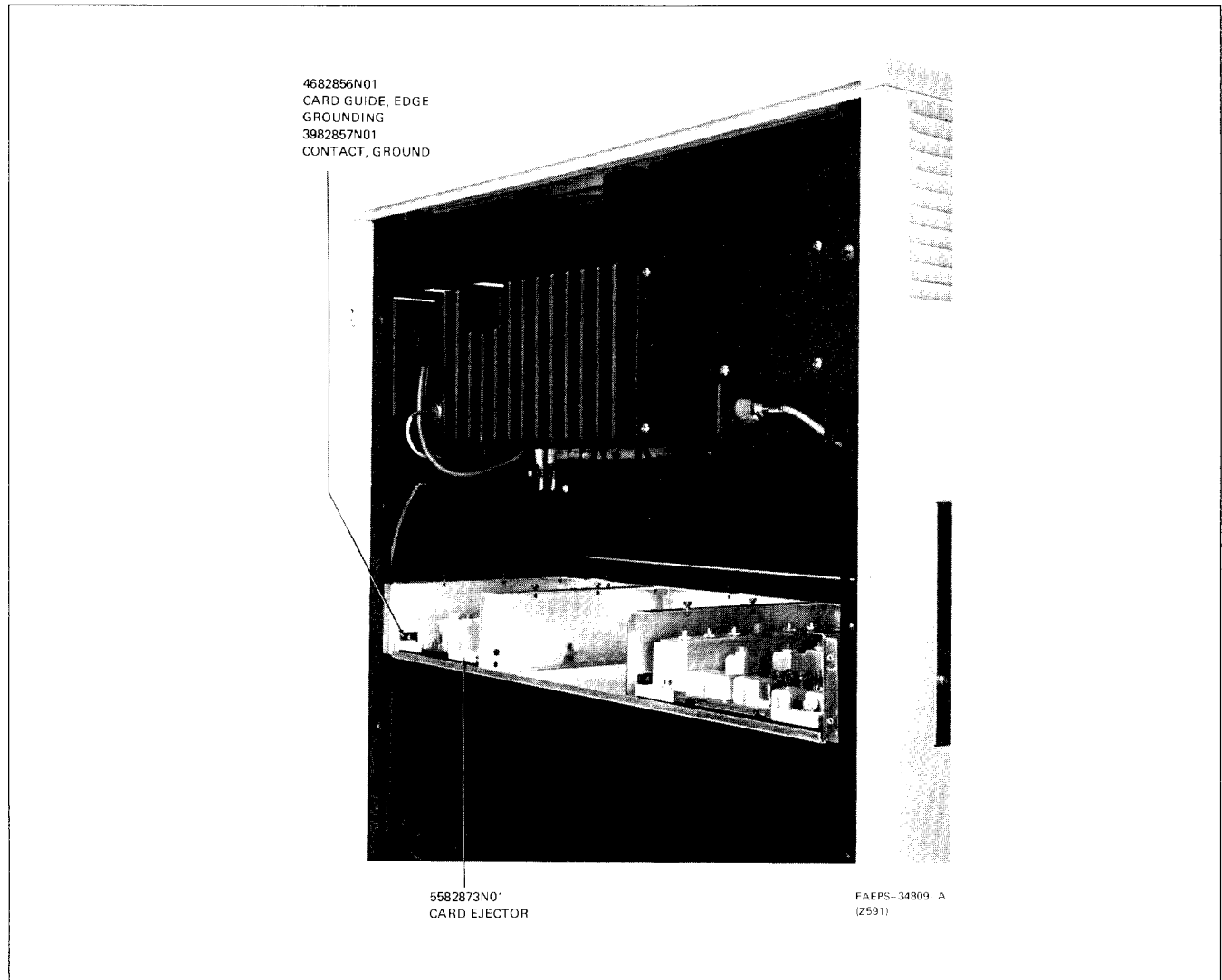
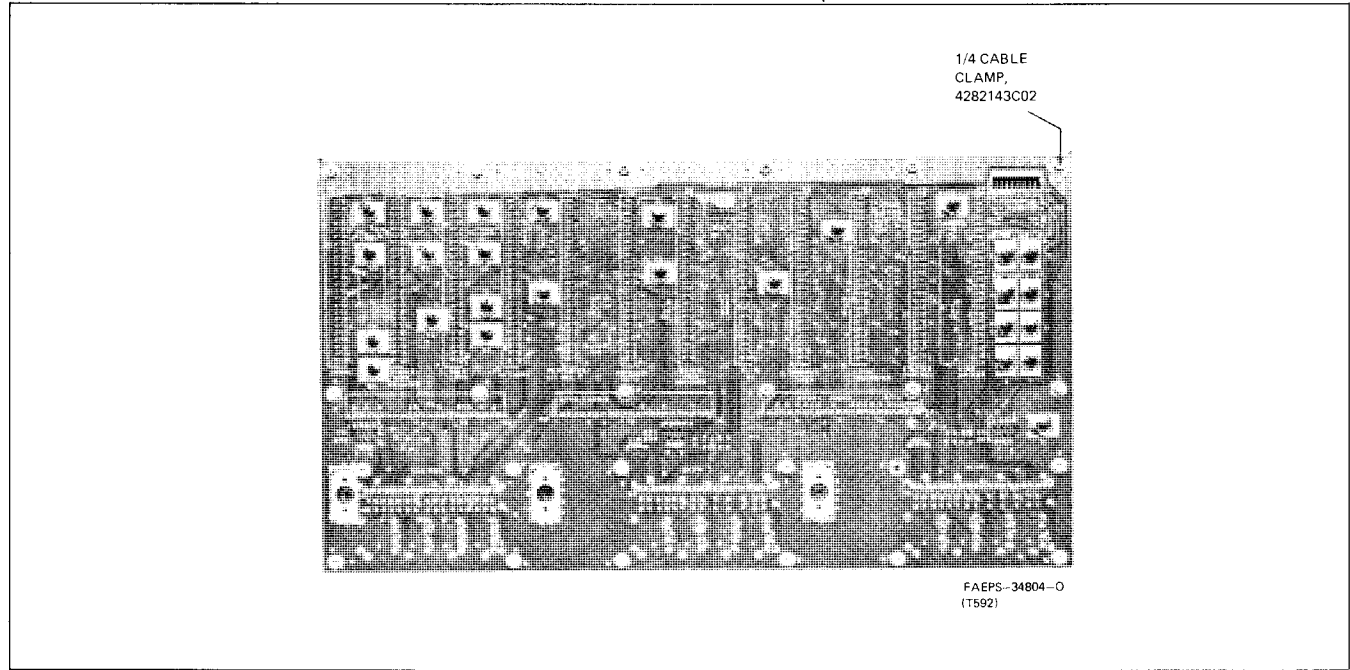

Figure 14. MSR 2000 Fully Optionable Model Station Mechanical Parts Identification





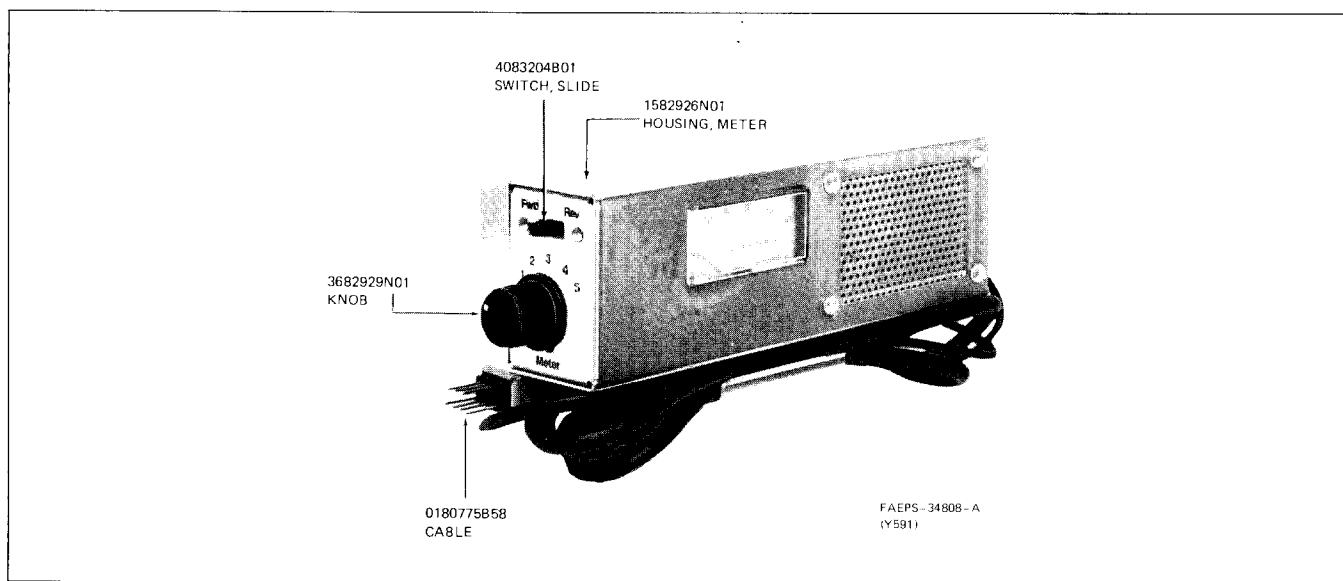
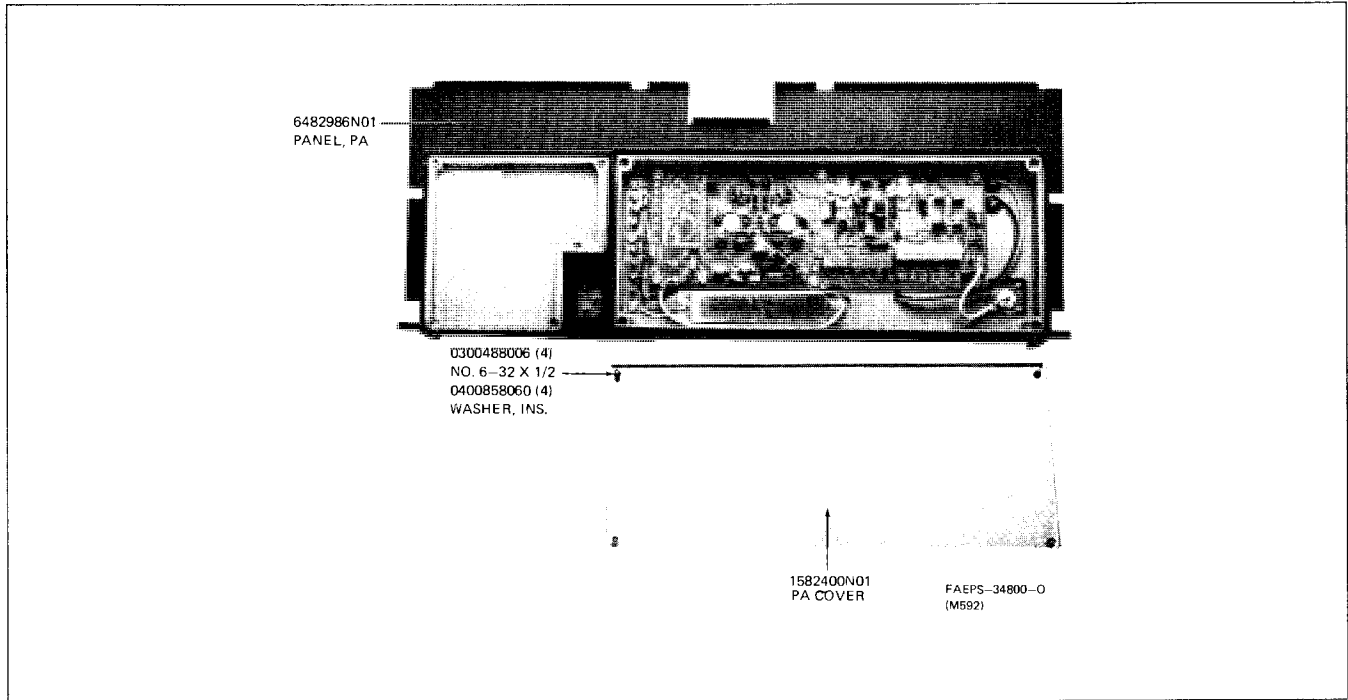

Figure 16. MSR 2000 Base Station Service Intercom with Speaker and DC Metering Chassis Mechanical Parts Identification

## INTERMITTENT DUTY POWER AMPLIFIER



## CONTINUOUS DUTY POWER AMPLIFIER

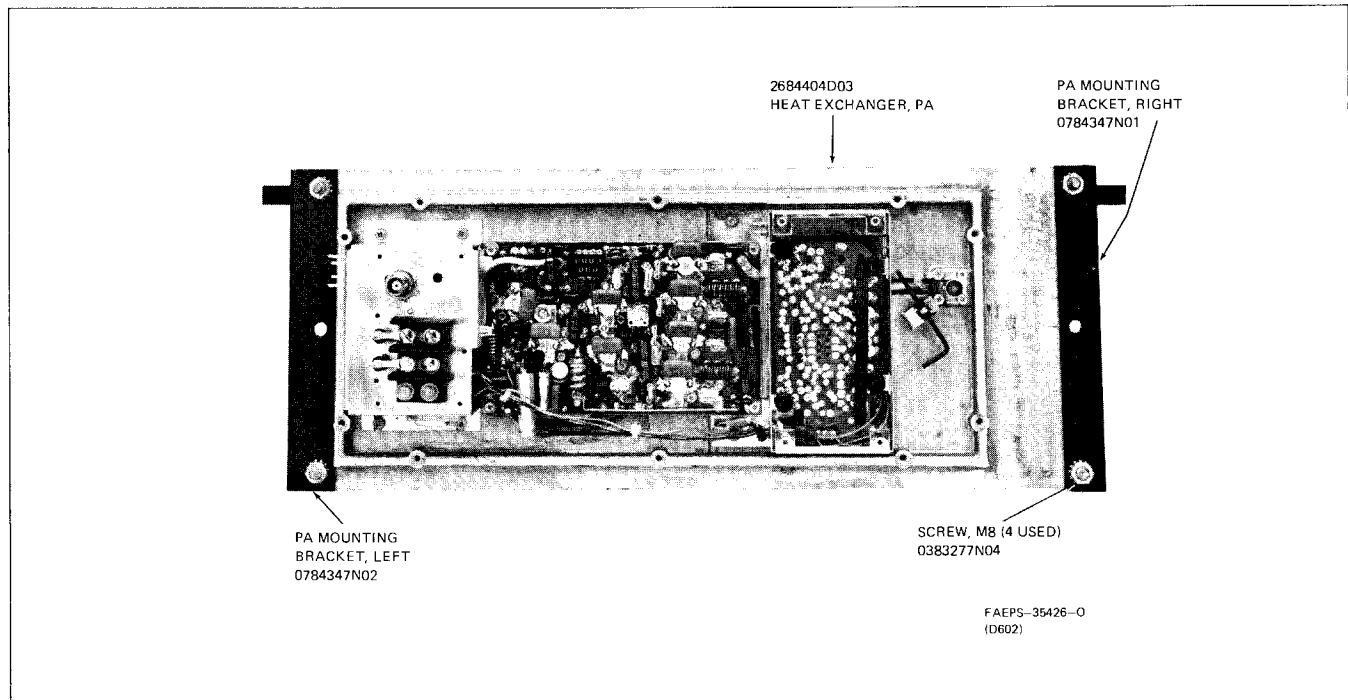

Figure 17. MSR 2000  
Base Station Power Amplifier  
Mechanical Parts Identification

**parts list**

TRN5423A 24" Cabinet Hardware PL-8041-C

| REFERENCE SYMBOL | MOTOROLA PART NO. | DESCRIPTION                             |
|------------------|-------------------|---|
|                  | 3-83677N01        | SCREW, captive: M6 x 1.0 x 2.0; 2 used  |
|                  | 42-10128A10       | RETAINER, ring; 2 used                  |
|                  | 43-84510G01       | SPACER; 2 used                          |
|                  | 4-10058B37        | WASHER, nylon; 6 used                   |
|                  | 3-10943J41        | SCREW, tapping: TT8 x 1.25 x 16; 4 used |
|                  | 3-83498N08        | SCREW, tapping: M6 x 1.0 x 10; 10 used  |
|                  | 3-83498N10        | SCREW, tapping: M3.5 x 0.6 x 8; 6 used  |
|                  | 7-82831N17        | FRAME, cabinet                          |
|                  | 7-82831N18        | FRAME, cabinet                          |
|                  | 7-82881N01        | BRACKET, pivot: right                   |
|                  | 7-82881N02        | BRACKET, pivot: left                    |
|                  | 15-82821N01       | HOUSING, bottom                         |
|                  | 42-10217A02       | TIE WRAPS (21 used)                     |
|                  | 42-82143C09       | CABLE CLAMPS, clear (7 used)            |
|                  | 42-82143C02       | CABLE CLAMPS, 1/4" (2 used)             |
|                  | 3-134186          | SCREW, tapping (2 used)                 |
|                  | 3-135500          | SCREW, tapping 4-40 x 1/4 (4 used)      |

TRN5425A 24" Cabinet Shell PL-8042-A

| REFERENCE SYMBOL | MOTOROLA PART NO. | DESCRIPTION                              |
|------------------|-------------------|--|
|                  | 3-10943J41        | SCREW, tapping: TT8 x 1.25 x 16; 4 used  |
|                  | 3-10943J45        | SCREW, tapping: TT8 x 1.25 x 40 (2 used) |
|                  | 15-82821N02       | HOUSING, top                             |
|                  | 15-82832N02       | COVER, wraparound                        |
|                  | 75-82154D17       | PAD, foam; 2 used                        |

TRN5424A Cabinet 29" Hardware PL-8070-C

| REFERENCE SYMBOL | MOTOROLA PART NO. | DESCRIPTION                             |
|------------------|-------------------|---|
|                  | 3-10943J41        | SCREW, tapping: TT8 x 1.25 x 16; 4 used |
|                  | 3-83498N08        | SCREW, tapping: M6 x 1.0 x 10; 10 used  |
|                  | 3-83498N10        | SCREW, tapping: M3.5 x 0.6 x 8; 6 used  |
|                  | 7-82831N19        | FRAME, cabinet                          |
|                  | 7-82831N20        | FRAME, cabinet                          |
|                  | 7-82881N01        | BRACKET, right                          |
|                  | 7-82881N02        | BRACKET, left                           |
|                  | 15-82821N01       | HOUSING, plastic                        |
|                  | 42-10217A02       | TIE WRAPS (21 used)                     |
|                  | 42-82143C09       | CABLE CLAMPS, clear (7 used)            |
|                  | 42-82143C02       | CABLE CLAMPS, 1/4" (2 used)             |
|                  | 3-134186          | SCREW, tapping (2 used)                 |
|                  | 3-135500          | SCREW, tapping 4-40 x 1/4 (6 used)      |
|                  | 4-10058B37        | WASHER, nylon; 6 used                   |

TRN5426A Cabinet 29" Shell PL-8071-A

| REFERENCE SYMBOL | MOTOROLA PART NO. | DESCRIPTION                             |
|------------------|-------------------|---|
|                  | 3-10943J41        | SCREW, tapping: TT8 x 1.25 x 16; 4 used |
|                  | 3-10943J45        | SCREW, tapping: TT8 x 1.25 x 40; 2 used |
|                  | 15-82821N02       | HOUSING, plastic top                    |
|                  | 15-82832N03       | COVER, cabinet                          |
|                  | 75-82154D17       | PAD, foam; 2 used                       |

TRN5569A Cabinet 32" Shell PL-8224-O

| REFERENCE SYMBOL | MOTOROLA PART NO. | DESCRIPTION                             |
|------------------|-------------------|---|
|                  | 3-10943J41        | SCREW, tapping TT8 x 1.25 x 16; 4 used  |
|                  | 3-10943J45        | SCREW, tapping: TT8 x 1.25 x 40; 2 used |
|                  | 15-82821N02       | HOUSING, tap                            |
|                  | 15-82832N04       | COVER, cabinet                          |
|                  | 75-82154D17       | PAD; 2 used                             |

TRN5428A Power Control Board Cover PL-8044-O

| REFERENCE SYMBOL | MOTOROLA PART NO. | DESCRIPTION                                    |
|------------------|-------------------|--|
|                  | 3-488006          | SCREW, machine: 6-32 x 1/2"; 5 used            |
|                  | 4-858060          | WASHER, insulator; 7/32 x 0.125 x .062; 5 used |
|                  | 15-82401N01       | COVER, control                                 |

**MSR 2000 BASE STATION  
MISCELLANEOUS PARTS LISTS**

TRN5567A Cabinet 32" Hardware PL-8222-B

| REFERENCE SYMBOL | MOTOROLA PART NO. | DESCRIPTION                                |
|------------------|-------------------|--|
|                  | 3-134186          | SCREW, tapping: 6-32 x 5/16"; 2 used       |
|                  | 3-10943J41        | SCREW, tapping: TT8 x 1.25 x 16"; 4 used   |
|                  | 3-83498N08        | SCREW, tapping; star; 12 used              |
|                  | 3-83498N10        | SCREW, tapping; star; 6 used               |
|                  | 7-82831N21        | FRAME, cabinet                             |
|                  | 7-82831N22        | FRAME, cabinet                             |
|                  | 7-82881N01        | BRACKET, pivot right                       |
|                  | 7-82881N02        | BRACKET, pivot left                        |
|                  | 15-82821N01       | HOUSING, bottom                            |
|                  | 42-10217A02       | STRAP, tie: 0.91 x 3.62 nylon WHT; 23 used |
|                  | 42-82143C09       | CLAMP, cable; 7 used                       |
|                  | 3-135500          | SCREW, tapping: 4-40 x 1/4"; 4 used        |
|                  | 42-82143C05       | CLAMP, cable; 2 used                       |
|                  | 4-10058B37        | WASHER, nylon; 6 used                      |
|                  | 42-83215P01       | TWIST CLAMP; 11 used                       |

TRN5570A Cabinet 37" Shell PL-8228-O

| REFERENCE SYMBOL | MOTOROLA PART NO. | DESCRIPTION                             |
|------------------|-------------------|---|
|                  | 3-10943J41        | SCREW, tapping: TT8 x 1.25 x 16; 4 used |
|                  | 3-10943J45        | SCREW, tapping: TT8 x 1.25 x 40; 2 used |
|                  | 15-82821N02       | HOUSING, top                            |
|                  | 15-82832N05       | COVER, cabinet                          |
|                  | 75-82154D17       | PAD; 2 used                             |

TRN5568A Cabinet 37" Hardware PL-8227-B

| REFERENCE SYMBOL | MOTOROLA PART NO. | DESCRIPTION                             |
|------------------|-------------------|---|
|                  | 3-134186          | SCREW, tapping: 6-32 x 5/16"; 2 used    |
|                  | 3-135500          | SCREW, tapping: 4-40 x 1/4"; 4 used     |
|                  | 3-10943J41        | SCREW, tapping: TT8 x 1.25 x 16; 4 used |
|                  | 3-83498N08        | SCREW, tapping: star; 12 used           |
|                  | 3-83498N10        | SCREW, tapping: star; 6 used            |
|                  | 7-82831N23        | FRAME, cabinet                          |
|                  | 7-82831N24        | FRAME, cabinet                          |
|                  | 7-82881N01        | BRACKET, pivot right                    |
|                  | 7-82881N02        | BRACKET, pivot left                     |
|                  | 15-82821N01       | HOUSING, bottom                         |
|                  | 42-10217A02       | STRAP, tie: .091 x 3.62 nylon; 23 used  |
|                  | 42-82143C05       | CLAMP, cable; 2 used                    |
|                  | 42-82143C09       | CLAMP, cable; 7 used                    |
|                  | 4-10058B37        | WASHER, nylon; 6 used                   |
|                  | 42-83215P01       | TWIST CLAMP; 11 used                    |

TRN5435A Hardware Optionable Control Chassis, Duplex PL-8051-A

| REFERENCE SYMBOL | MOTOROLA PART NO. | DESCRIPTION   |
|------------------|-------------------|---|
|                  | 3-134185          | SCREW, tapping: 6-32 x 1/4"; 4 used                         |
|                  | 3-134186          | SCREW, tapping: 6-32 x 5/16"                                |
|                  | 3-135506          | SCREW, tapping: 6-32 x 1/4"; 23 used                        |
|                  | 27-82850N01       | CHASSIS, rf   |
|                  | 27-82876N01       | CHASSIS, card cage  |
|                  | 39-82857N01       | CONTACT, ground; 6 used                                     |
|                  | 42-82888N01       | CLIP, detent; 2 used  |
|                  | 46-82856N01       | GUIDE, circuit board card; 6 used                           |
|                  | 46-82877N01       | GUIDE, skt, bd. mntg: (3 used; TRN5434A) (2 used; TRN5435A) |
|                  | 54-83570K01       | LABEL   |

# MSR 2000 BASE STATION

## MISCELLANEOUS PARTS LISTS

### parts list

TRN5431A Cover Repeater PL-8088-O

| REFERENCE SYMBOL | MOTOROLA PART NO. | DESCRIPTION                  |
|------------------|-------------------|------------------------------|
|                  | 2-82360B35        | NUT, speed                   |
|                  | 3-125178          | SCREW, machine: 8-32 x 3/4"  |
|                  | 3-83498N02        | SCREW, tapping: M3 x 0.5 x 5 |
|                  | 4-647583          | WASHER, fiber                |
|                  | 14-82935N01       | INSULATOR, terminal block    |
|                  | 15-82858N01       | COVER, mode F0               |
|                  | 15-83031N01       | COVER, aux, chassis          |
|                  | 42-10128A10       | RETAINER, ring rubber        |

TRN5433A Hardware Optional Control Chassis (1-Receiver) PL-8089-O

| REFERENCE SYMBOL | MOTOROLA PART NO. | DESCRIPTION                           |
|------------------|-------------------|---------------------------------------|
|                  | 3-134185          | SCREW, tapping: 6-32 x 1/4"; 4 used   |
|                  | 3-134186          | SCREW, tapping: 6-32 x 5/16"          |
|                  | 3-135506          | SCREW, tapping: 6-32 x 1/4"; 23 used  |
|                  | 27-82850N01       | CHASSIS, rf                           |
|                  | 27-82876N01       | CHASSIS, card cage                    |
|                  | 39-82857N01       | CONTACT, ground; 4 used               |
|                  | 42-82888N01       | CLIP, detent; 2 used                  |
|                  | 46-82856N01       | GUIDE, circuit board card; 4 used     |
|                  | 46-82877N01       | GUIDE, circuit board mounting; 2 used |
|                  | 54-83570K01       | LABEL                                 |

TKN8326A Cable Kit PL-8226-A

| REFERENCE SYMBOL | MOTOROLA PART NO. | DESCRIPTION                       |
|------------------|-------------------|-----------------------------------|
|                  | 1-80763D70        | CABLE, coaxial assembly includes: |
|                  | 28-84282D01       | PLUG, single contact (1 used)     |
|                  | 28-82875N01       | PLUG, phono; board mount (1 used) |
|                  | 30-83794C01       | COAX CABLE; 45" long              |
|                  | 1-80757D15        | CABLE, coaxial assembly includes: |
|                  | 28-82331G01       | PLUG, single contact (1 used)     |
|                  | 30-83794C01       | COAX CABLE; 3 1/2" long           |
|                  | 42-10217A02       | STRAP, tie (6 used)               |

TRN5575A Power Supply Cover PL-8206-O

| REFERENCE SYMBOL | MOTOROLA PART NO. | DESCRIPTION                  |
|------------------|-------------------|------------------------------|
|                  | 3-83498N08        | SCREW, tapping; star; 5 used |
|                  | 26-84448N01       | SHIELD, top                  |
|                  | 26-84384N01       | SHIELD                       |

TRN5443A Duplex RF Cover PL-8039-O

| REFERENCE SYMBOL | MOTOROLA PART NO. | DESCRIPTION                            |
|------------------|-------------------|--|
|                  | 1-80756D69        | Assembly Front cover eyeleted          |
|                  | 3-136932          | SCREW, tapping: 4 x 40 x 3/8"; 15 used |
|                  | 3-138430          | SCREW, tapping: 4-24 x 3/8"; 4 used    |
|                  | 15-82852N01       | COVER, top                             |
|                  | 42-83123F01       | RETAINER; 4 used                       |

TRN5429A Cover, Basic  
TRN5430A Cover, Simplex PL-8040-A

| REFERENCE SYMBOL | MOTOROLA PART NO. | DESCRIPTION                         |
|------------------|-------------------|-------------------------------------|
|                  | 1-80758D68        | ASSEMBLY COVER; includes:           |
|                  | 5-83124F01        | EYELET; 2 used                      |
|                  | 15-82851N01       | COVER                               |
|                  | 2-82360B35        | NUT, speed                          |
|                  | 3-125178          | SCREW, machine: 8-32 x 3/4"         |
|                  | 3-138430          | SCREW, tapping: 4-24 x 3/8"; 2 used |
|                  | 3-83498N02        | SCREW, tapping: M3 x 0.5 x 5        |
|                  | 4-647583          | WASHER, fiber                       |
|                  | 14-82935N01       | INSULATOR, terminal block           |
|                  | 15-82858N01       | COVER, mode F0 (TRN5430A)           |
|                  | 15-82858N02       | COVER, mode basic (TRN5429A)        |
|                  | 15-83031N01       | COVER, aux chassis                  |
|                  | 42-10128A10       | RETAINER, ring rubber               |
|                  | 42-83123F01       | RETAINER; 2 used                    |
|                  | 42-82879N01       | CLIP; 3 used                        |

# MSR 2000 INTERMITTENT DUTY BASE STATION

## RF INTERCABLING DIAGRAM & PARTS LIST

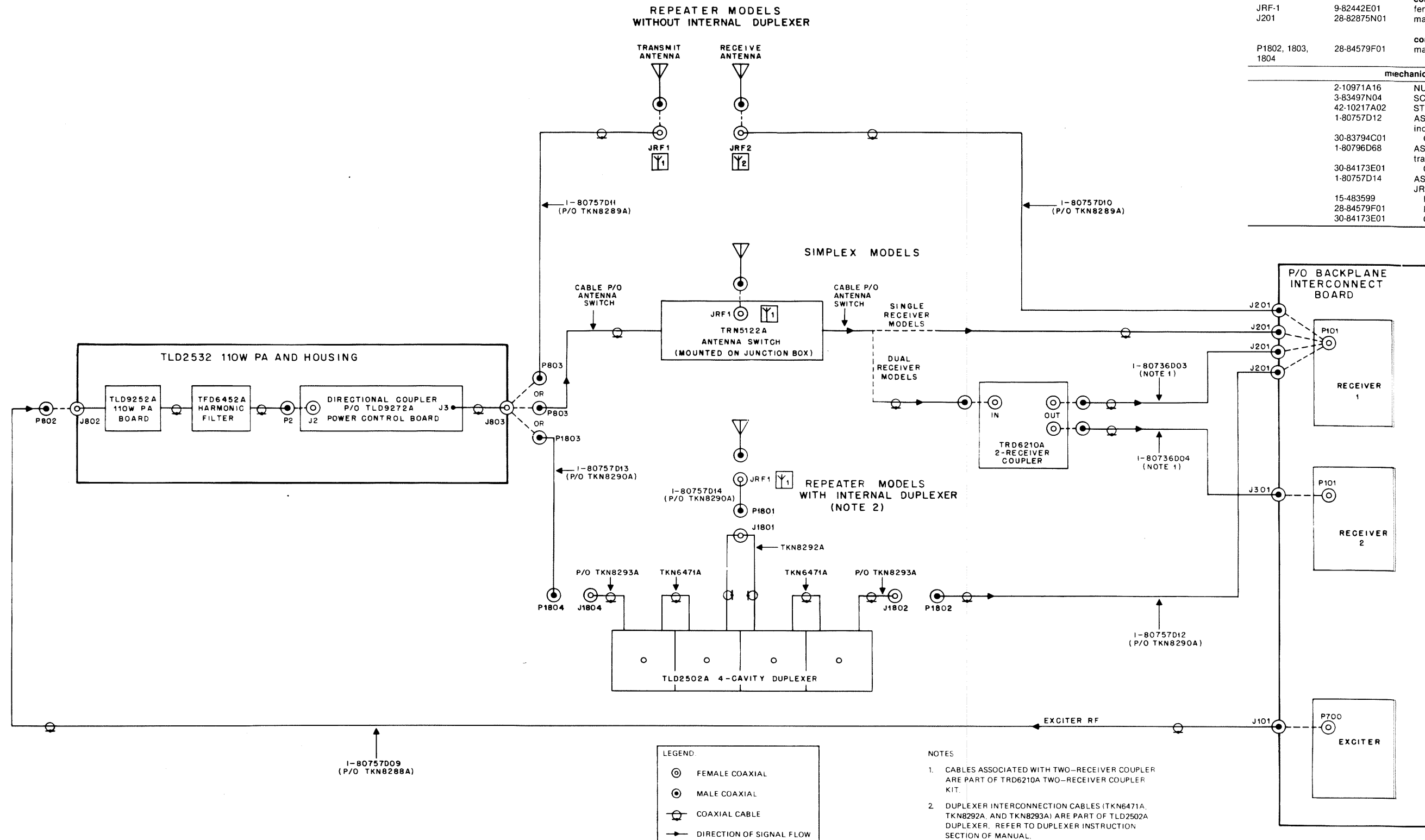

### parts list

| REFERENCE SYMBOL                        | MOTOROLA PART NO.         | DESCRIPTION  |
|---|---------------------------|--|
| JRF-1<br>J201                           | 9-82442E01<br>28-82875N01 | connector:<br>female; single contact<br>male; single contact   |
| P1802, 1803,<br>1804                    | 28-84579F01               | connector, plug:<br>male; single contact   |
| <b>mechanical parts</b>                 |                           |  |
| 2-10971A16                              |                           | NUT, machine: M3 x 0.5; 4 used   |
| 3-83497N04                              |                           | SCREW, machine: M3 x 0.5 x 8; 4 used   |
| 42-10217A02                             |                           | STRAP, tie; 2 used   |
| 1-80757D12                              |                           | ASSEMBLY, cable receiver:<br>includes J201, P1804  |
| 30-83794C01<br>1-80796D68               |                           | CABLE, coaxial; 38-1/2" used<br>ASSEMBLY, cable  |
| 30-84173E01<br>1-80757D14               |                           | transmitter: includes: P1802, 1803<br>CABLE, coaxial; 36" used<br>ASSEMBLY, cable antenna: includes<br>JRF-1 |
| 15-483599<br>28-84579F01<br>30-84173E01 |                           | HOOD, receptacle<br>PLUG, UHF<br>CABLE, coaxial; 33" used  |

| REFERENCE SYMBOL                        | MOTOROLA PART NO.         | DESCRIPTION  |
|---|---------------------------|--|
| JRF-1<br>J201                           | 9-82442E01<br>28-82875N01 | connector:<br>female; single contact<br>male; single contact   |
| P1802, 1803,<br>1804                    | 28-84579F04               | connector, plug:<br>male; single contact   |
| <b>mechanical parts</b>                 |                           |  |
| 2-10971A16                              |                           | NUT, machine: M3 x 0.5; 4 used   |
| 3-83497N04                              |                           | SCREW, machine: M3 x 0.5 x 8; 4 used   |
| 42-10217A02                             |                           | STRAP, tie; 2 used   |
| 1-80757D12                              |                           | ASSEMBLY, cable receiver:<br>includes J201, P1804  |
| 30-83794C01<br>1-80757D13               |                           | CABLE, coaxial; 40" used<br>ASSEMBLY, cable  |
| 30-82921H01<br>1-80757D14               |                           | transmitter: includes: P1802, 1803<br>CABLE, coaxial; 44" used<br>ASSEMBLY, cable antenna: includes<br>JRF-1 |
| 15-483599<br>28-84579F01<br>30-84173E01 |                           | HOOD, receptacle<br>PLUG, UHF<br>CABLE, coaxial; 33" used  |

| REFERENCE SYMBOL                       | MOTOROLA PART NO.                                      | DESCRIPTION  |
|--|--|--|
| JRF1<br>JRF2<br>J201<br>P803           | 9-82442E01<br>9-82442E01<br>28-82875N01<br>28-84579F01 | connector, receptacle:<br>female; single contact<br>female; single contact<br>male; single contact (phono)<br>male; single contact (UHF) |
| <b>mechanical parts</b>                |  |  |
| 2-10971A16                             |  | NUT, machine: M3 x 0.5; 8 used   |
| 3-83497N04                             |  | SCREW, machine: M3 x 0.5 x 8; 8 used   |
| 1-80757D10                             |  | ASSEMBLY, cable non-duplexer rcvr<br>includes:<br>JRF2, J201   |
| 15-483599<br>30-83794C01<br>1-80757D11 |  | HOOD, receptacle<br>CABLE, coaxial (WHT) 47 1/2" used<br>Assembly cable, non-duplexer xtrm;<br>includes:<br>JRF1, P803                   |
| 15-483599<br>30-84173E01               |  | HOOD, receptacle<br>CABLE, coaxial (double shield)<br>19 1/2" used   |

| REFERENCE SYMBOL                                      | MOTOROLA PART NO.          | DESCRIPTION  |
|---|----------------------------|--|
| J101<br>P802  | 28-82875N01<br>28-84579F04 | connector, plug:<br>male; single contact (phono)<br>male; single contact (UHF)                           |
| <b>mechanical parts</b>                               |                            |  |
| 1-80757D07  |                            | Assembly, cable: PA power red; includes:<br>TERMINAL, ring; 2 used                                       |
| 29-82907N05<br>1-80757D08                             |                            | Assembly, cable: PA power black;<br>includes:<br>TERMINAL, ring; 1 used                                  |
| 29-82709N05<br>29-848903<br>1-80757D12                |                            | TERMINAL, lug<br>Assembly, cable: exciter; includes<br>J801, P802  |
| 30-82921H01<br>3-134185<br>42-10217A02<br>42-82143C05 |                            | CABLE, coaxial (WHT) 40" used<br>SCREW, tapping; 6-32 x 1/4"<br>STRAP, tie; (WHT); 3 used<br>CLIP, cable |

DEPS-34372-A

# MSR 2000 INTERMITTENT DUTY BASE STATION

## TKN8234B MAIN WIRING HARNESS

### SCHEMATIC DIAGRAM AND PARTS LIST

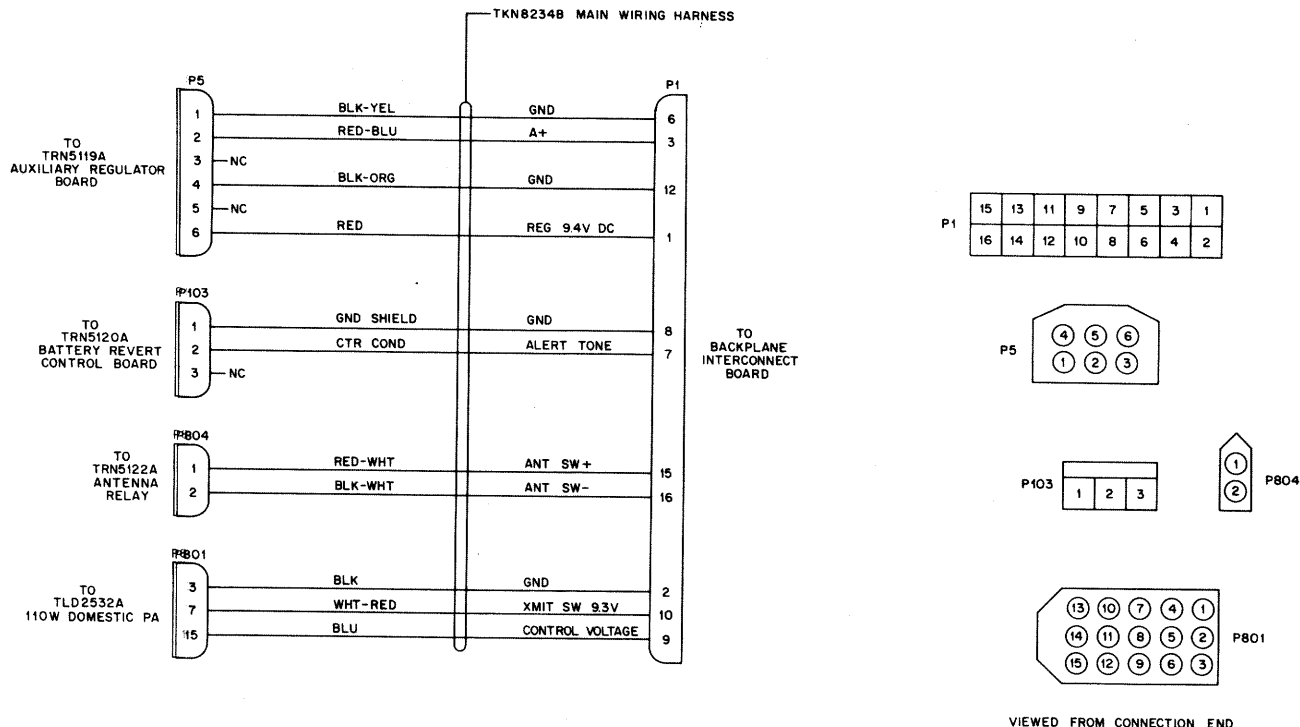

DEPS-34674-A

## parts list

TKN8234B Main Cable

PL-8053-C

| REFERENCE SYMBOL              | MOTOROLA PART NO. | DESCRIPTION                        |
|-------------------------------|-------------------|------------------------------------|
| <b>connector, receptacle:</b> |                   |                                    |
| P1                            | 15-84248N01       | 16 position                        |
| P5                            | 15-84954L01       | 6 position                         |
| P103                          | 15-83498F39       | 3 position                         |
| P801                          | 15-83292K02       | 15 position                        |
| P804                          | 15-84860K02       | 2 position                         |
| <b>mechanical parts</b>       |                   |                                    |
|                               | 29-84249N01       | TERMINAL; 11 used                  |
|                               | 29-84706E05       | TERMINAL: crimp pin; 4 used        |
|                               | 29-84706E06       | TERMINAL: crimp socket; 5 used     |
|                               | 30-824278         | CABLE, shielded (ORG) 49 1/4" used |
|                               | 42-10217A02       | STRAP, tie; 18 used                |
|                               | 29-83499F01       | TERMINAL; 2 used                   |

# MSR 2000 CONTINUOUS DUTY BASE STATION

## RF INTERCABLING DIAGRAM & PARTS LIST

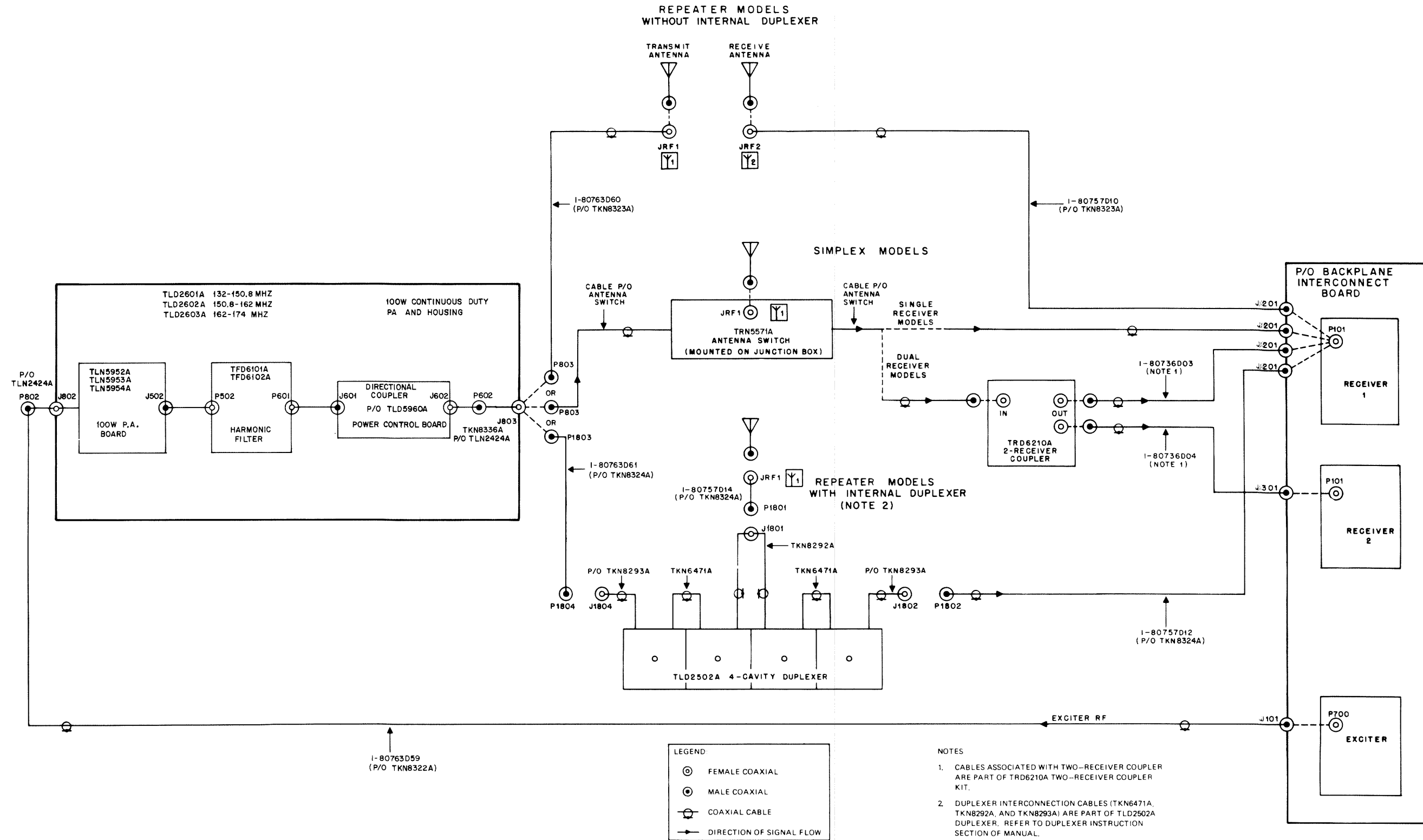

### parts list

TKN8324A Cable Duplexer PL-8220-A

| REFERENCE SYMBOL | MOTOROLA PART NO. | DESCRIPTION                                   |
|------------------|-------------------|---|
| JRF1             | 9-82442E01        | connector, receptacle: female; single-contact |
| J201             | 28-82875N01       | male; single-contact (phono)                  |
| P1801, 1802      | 28-84579F04       | connector, plug: male; single-contact         |
| P1803            | 28-84967D01       | male; single-contact                          |
| P1804            | 28-84579F01       | male; single-contact                          |

**mechanical parts**

|             |  |
|-------------|--|
| 1-80757D12  | ASSEMBLY CABLE DUPLEXER (RCVR)               |
| includes:   |  |
| J201, P1804 | eyelet                                       |
| 5-82050H04  | CABLE, coaxial (WHT) 30" used                |
| 30-82921H01 | ASSEMBLY CABLE ANTENNA DU- PLEXER;           |
| 1-80754D14  | includes:                                    |
| JRF1, P1801 | HOOD, receptacle                             |
| 15-483599   | CABLE, coaxial double shielded; 30-1/2" used |
| 30-82921H01 | ASSEMBLY CABLE DUPLEXER (XMTR)               |
| 1-80763D61  | includes:                                    |
| P1802, 1803 | CABLE, coaxial; 62" used                     |
| 30-8173E01  | NUT, machine; M3 x 0.5; 4 used               |
| 2-10971A16  | SCREW, machine; M3 x 0.5 x 8; 4 used         |
| 3-83497N04  | STRAP, tie .091 x 3.62 nylon; 2 used         |
| 42-10217A02 |  |

TKN8323 Cable Non-Duplexer PL-8231-O  
TKN8329A Cable Non-Duplexer EIA Rack

| REFERENCE SYMBOL | MOTOROLA PART NO. | DESCRIPTION   |
|------------------|-------------------|---|
| JRF1, 2          | 9-82442E01        | connector, receptacle: female; single-contact (UHF) |
| J201             | 29-82875N01       | male; single-contact (phono)                        |
| P803             | 28-84967D01       | male; single-contact (BNC)                          |

**mechanical parts**

|             |  |
|-------------|--|
| 1-80757D10  | ASSEMBLY CABLE, non-duplexer, RCVR;          |
| includes:   |  |
| JRF2, J201  | EYELET                                       |
| 5-82050H04  | HOOD, receptacle                             |
| 15-483599   | CABLE, coaxial (WHT) 46" used                |
| 30-83794C01 | ASSEMBLY CABLE, non-duplexer EIA rack        |
| 1-80763D65  | includes:                                    |
| 15-483599   | HOOD, receptacle                             |
| 30-84173E01 | CABLE, coaxial shielded; 36" used (TKN8329A) |
| 1-80763D60  | ASSEMBLY CABLE, non-duplexer XMTR            |
| includes:   |  |
| JRF1, P803  | HOOD, receptacle                             |
| 15-483599   | CABLE, coaxial shielded 28" used (TKN8323A)  |
| 30-84173E01 |  |

TKN8328A Cable PA Power and Exciter EIA Rack PL-8223-B  
TKN8322A Cable PA Power and Exciter

| REFERENCE SYMBOL | MOTOROLA PART NO. | DESCRIPTION                                   |
|------------------|-------------------|---|
| J101             | 28-82875N01       | connector, plug: male; single-contact (phono) |
| P802             | 28-83099K01       | male; single-contact (BNC)                    |

**mechanical parts**

|             |  |
|-------------|--|
| 1-80763D57  | ASSEMBLY CABLE, PA power, RED;           |
| includes:   |  |
| 29-82907N05 | TERMINAL, ring; 2 used                   |
| 1-80763D58  | ASSEMBLY CABLE; PA power, BLK;           |
| includes:   |  |
| 29-848903   | LUG, crimp terminal                      |
| 1-80763D59  | ASSEMBLY CABLE, exciter; includes:       |
| J801, P802  | EYELET                                   |
| 5-82050H04  | CABLE, coaxial (WHT) 51" used (TKN8322A) |
| 30-83794C01 | ASSEMBLY CABLE, exciter; (EIA)           |
| 1-80763D64  | includes:                                |
| J801, P802  | EYELET                                   |
| 5-82050H04  | CABLE, coaxial (WHT) 64" used (TKN8328A) |
| 30-83794C01 |  |



# MSR 2000 CONTINUOUS DUTY BASE STATION

## TKN8319A MAIN WIRING HARNESS

### SCHEMATIC DIAGRAM AND PARTS LIST

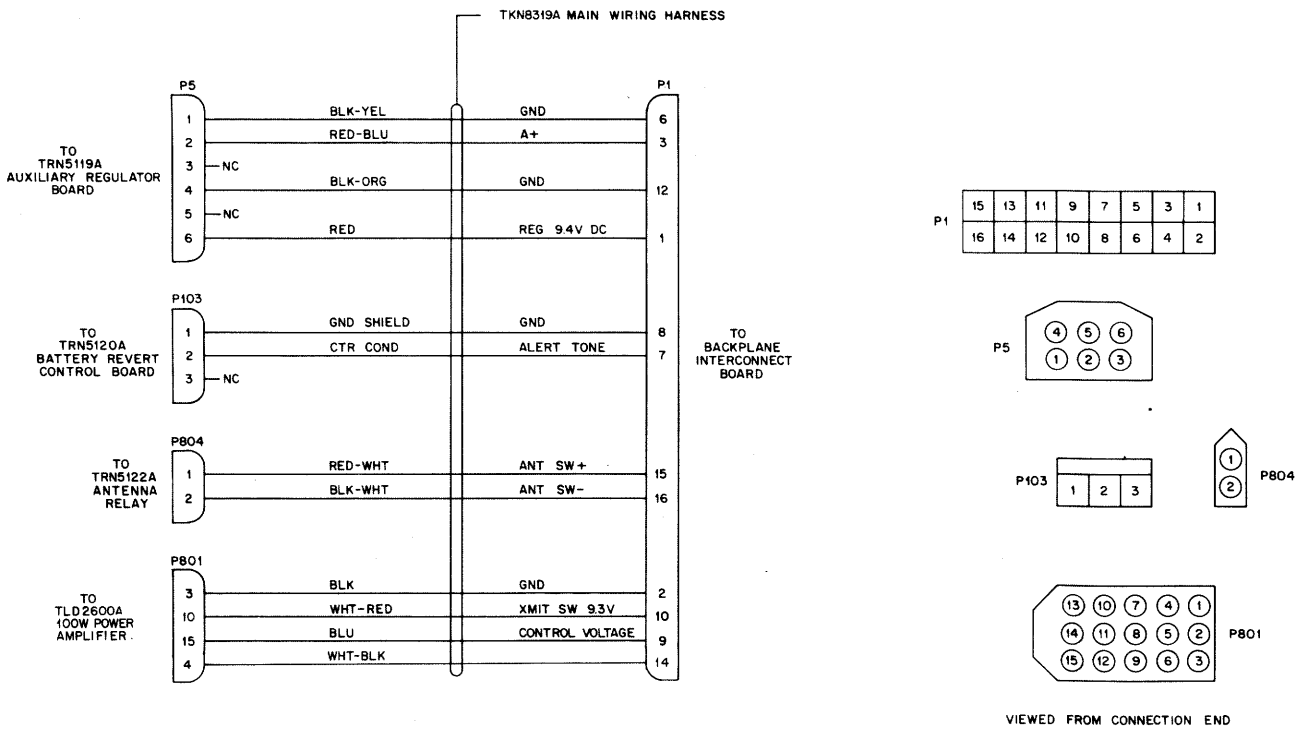

DEPS-35287-0

### parts list

TKN8319A Main Cable

PL-8225-0

| REFERENCE SYMBOL              | MOTOROLA PART NO. | DESCRIPTION                    |
|-------------------------------|-------------------|--------------------------------|
| <b>connector, receptacle:</b> |                   |                                |
| P1                            | 15-84248N01       | 16 position                    |
| P5                            | 15-84954L01       | 6 position                     |
| P103                          | 15-83498F39       | 3 position                     |
| P801                          | 15-83292K02       | 15 position                    |
| P804                          | 15-84860K02       | 2 position                     |
| <b>mechanical parts</b>       |                   |                                |
|                               | 29-84249N01       | TERMINAL; 12 used              |
|                               | 29-83499F01       | TERMINAL; 2 used               |
|                               | 29-84706E05       | TERMINAL: crimp pin; 4 used    |
|                               | 29-84706E06       | TERMINAL: crimp socket; 6 used |
|                               | 30-824278         | CABLE, shielded (ORG) 52" used |
|                               | 42-10217A02       | STRAP, tie; 47 used            |

# 2-WIRE & 4-WIRE EIA CABLE KIT

TKN8320A AND TKN8321A

# 2-WIRE & 4-WIRE LINE CABLE KIT

TKN8286A AND TKN8287A

## SCHEMATIC DIAGRAM AND PARTS LIST

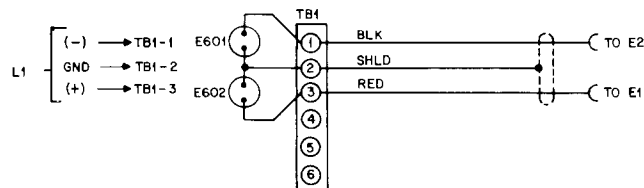

TKN8286A TWO-WIRE LINE CABLE KIT

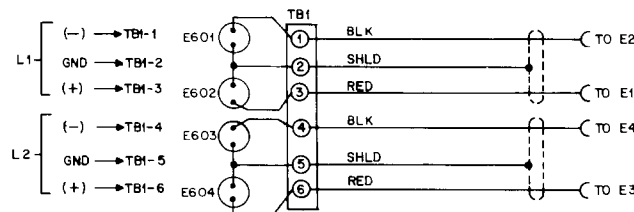

TKN8287A FOUR-WIRE LINE CABLE KIT

•BEPS-34736-0

### parts list

TKN8320A and TKN8321A Two-Wire and Four-Wire EIA Cable Kit  
 TKN8286A and TKN8287A Two-Wire and Four-Wire Line Cable Kit PL-8052-B

| REFERENCE SYMBOL        | MOTOROLA PART NO. | DESCRIPTION  |
|-------------------------|-------------------|--|
| E601 thru 604           | 80-83029H01       | spark, gap:<br>240 V   |
| <b>mechanical parts</b> |                   |  |
|                         | 29-83883C02       | LUG, crimp terminal: TKN8286A, TKN8320A; 2 used; TKN8287A, TKN8321A;<br>4 used |
|                         | 30-844810         | CABLE, 2-conductor shielded; 31-1/2" used<br>(TKN8287A, TKN8286A)              |
|                         | 30-844810         | CABLE, 2-conductor shielded; 34" used<br>(TKN8287A)                            |
|                         | 30-844810         | CABLE, 2-conductor shielded; 38" used<br>(TKN8321A, TKN8320A)                  |
|                         | 30-844810         | CABLE, 2-conductor shielded; 40-1/2" used<br>(TKN8321A)                        |
|                         | 31-84145N03       | TERMINAL, block with mounting rings  |
|                         | 42-10217A02       | STRAP, tie; TKN8286A, TKN8320A; 2 used;<br>TKN8287A, TKN8321A; 2 used          |

# JUNCTION BOX MODEL TRN9113A/14A

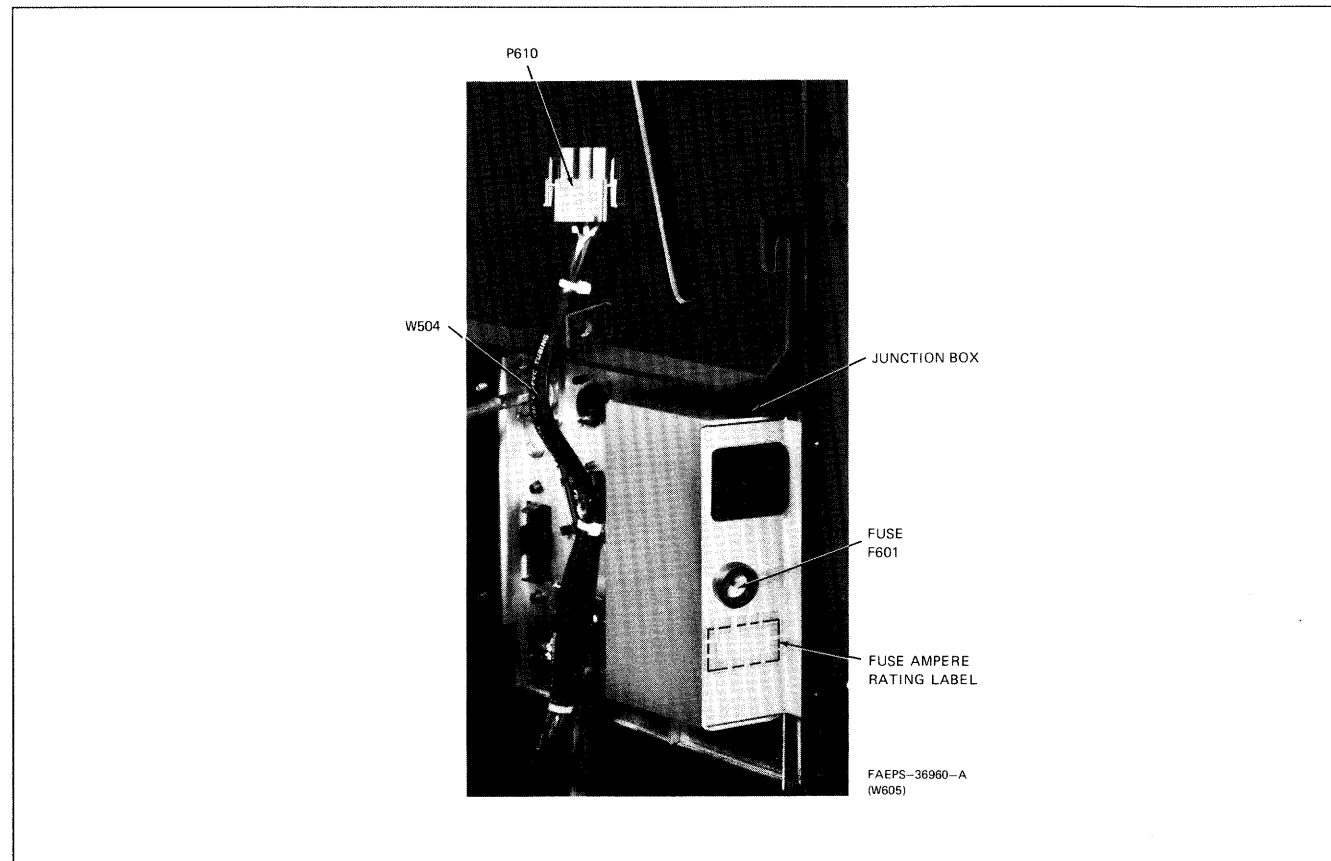
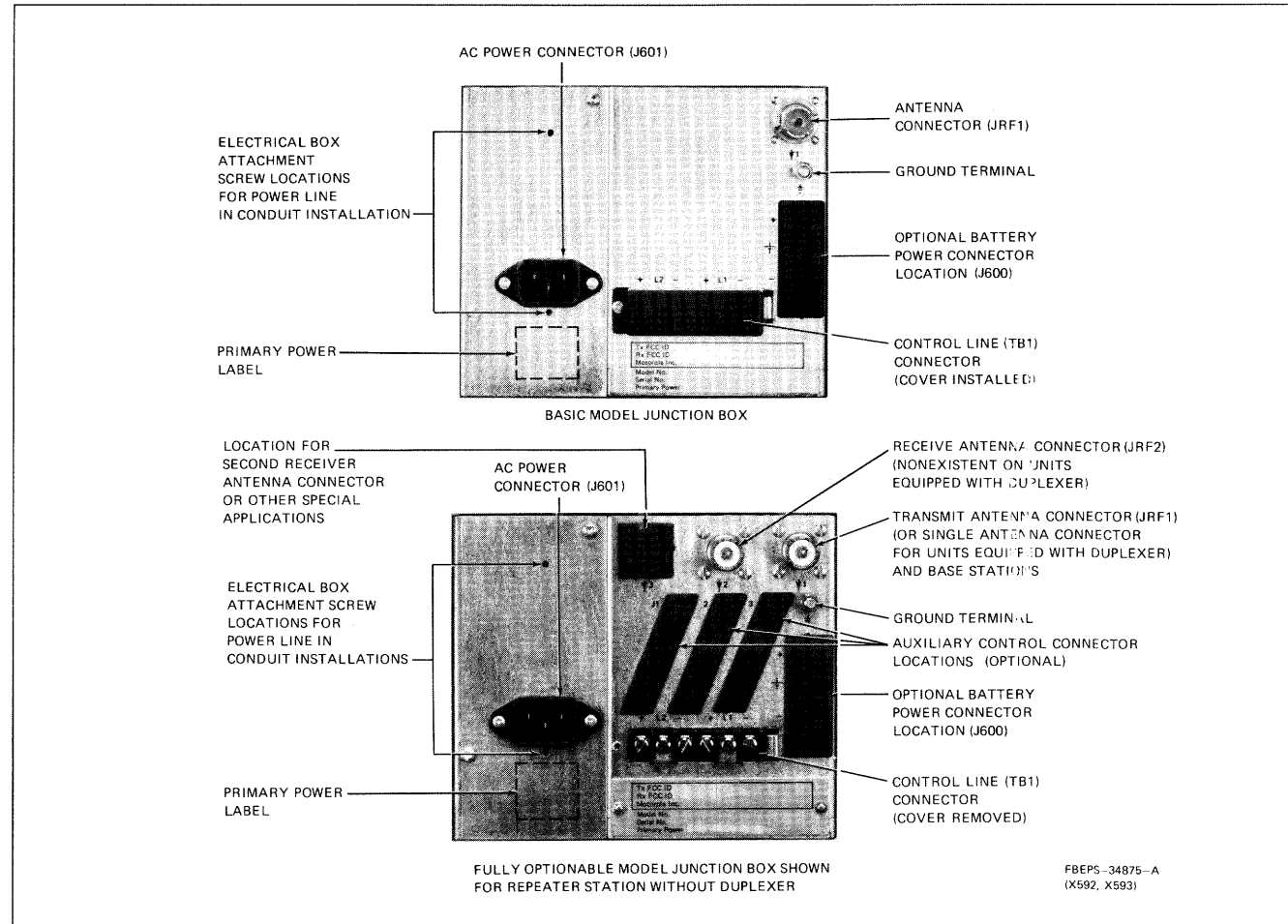

## parts list

TRN9114A Junction Box, Basic PL-8710-A  
TRN9113A Junction Box, Fully Optional

| REFERENCE SYMBOL        | MOTOROLA PART NO. | DESCRIPTION   |
|-------------------------|-------------------|---|
| J611                    | 15-82889N01       | <b>connector, receptacle:</b><br>HOUSING, 3-contact, power cord |
| P610                    | 15-83183N01       | <b>connector, plug:</b><br>HOUSING, 3-contact                   |
| <b>mechanical parts</b> |                   |   |
| 2-10971A16              |                   | NUT, machine: M3 x 0.5; 2 used                                  |
| 2-10971A19              |                   | NUT, machine: M6 x 1; 2 used                                    |
| 3-10908A55              |                   | SCREW, machine: M6 x 1 x 25mm                                   |
| 3-83497N04              |                   | SCREW, machine: M3 x 0.5 x 8mm; 2 used                          |
| 3-10943M10              |                   | SCREW, tapping: M3 x 0.5 x 8mm; 2 used                          |
| 3-83497N07              |                   | SCREW, machine: slotted star                                    |
| 3-83498N10              |                   | SCREW, tapping: M3.5 x 0.6 x 8mm; 2 used                        |
| 4-7683                  |                   | LOCKWASHER, #4 internal; 2 used                                 |
| 4-119331                |                   | LOCKWASHER, 1/4"; split   |
| 15-82834N04             |                   | HOUSING, interconnect (TRN9114A)                                |
| 15-83834N05             |                   | HOUSING, interconnect (TRN9113A)                                |
| 15-82835N01             |                   | COVER, junction box   |
| 15-82891N01             |                   | HOUSING, fuse with mounting hardware                            |
| 29-82607B04             |                   | LUG, ring tongue; 2 used  |
| 37-106352               |                   | GROMMET   |
| 38-83667N01             |                   | CAP, convenience outlet   |
| 39-83145N01             |                   | CONTACT, plug: (part for P610); 2 used                          |
| 39-83145N02             |                   | CONTACT, plug: (part for P610)                                  |
| 39-83384N01             |                   | CONTACT, plug: (part for J11); 3 used                           |
| 42-10217A02             |                   | STRAP, tie: .019 x 3.62 nylon; 3 used                           |
| 42-82143C01             |                   | CLIP, cable; 3/16"  |

TRN5352A RF Connector Plastic Plug  
TRN5353A Auxiliary Connector Plastic Plug  
TRN5354A Outlet Connector Plastic Plug  
TRN5355A Battery Connector Plastic Plug PL-8240-O

| REFERENCE SYMBOL | MOTOROLA PART NO. | DESCRIPTION                             |
|------------------|-------------------|---|
| 38-8366N01       |                   | CAP, rf port hole (TRN5352A)            |
| 38-83665N01      |                   | CAP, auxiliary hole (TRN5353A)          |
| 38-83667N01      |                   | CAP, convenience outlet hole (TRN5354A) |
| 38-83664N01      |                   | CAP, battery hole (TRN5355A)            |

TRN9109A Hardware and Label Kit (50 Hz) PL-8711-A  
TRN9110A Hardware and Label Kit (60 Hz)

| REFERENCE SYMBOL        | MOTOROLA PART NO. | DESCRIPTION                                   |
|-------------------------|-------------------|---|
| F601                    | 65-82847N02       | fuse:<br>5A; 250 V (220 V ac line) (TRN9109A) |
|                         | 65-138179         | 10A; 250 V (120 V ac line) (TRN9110A)         |
| <b>mechanical parts</b> |                   |   |
| 13-813618               |                   | DECAL, patent no.                             |
| 33-83748N02             |                   | NAMEPLATE                                     |
| 38-82892N01             |                   | CAP, fuse housing (TRN9110A)                  |
| 38-82892N02             |                   | CAP, fuse housing (TRN9109A)                  |
| 54-82928P01             |                   | LABEL, AC power (50 Hz) (TRN9109A)            |
| 54-82928P02             |                   | LABEL, AC power (60 Hz) (TRN9110A)            |
| 54-83040C01             |                   | LABEL, audio                                  |
| 54-84126C01             |                   | LABEL, replacement parts                      |
| 54-83604P01             |                   | LABEL, VLTG setting                           |
| 54-83609P02             |                   | LABEL, VLTG setting                           |

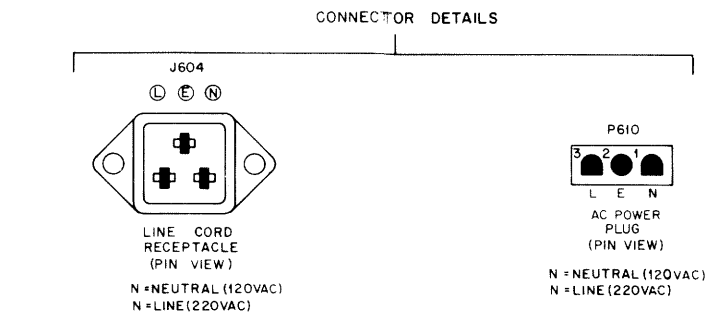
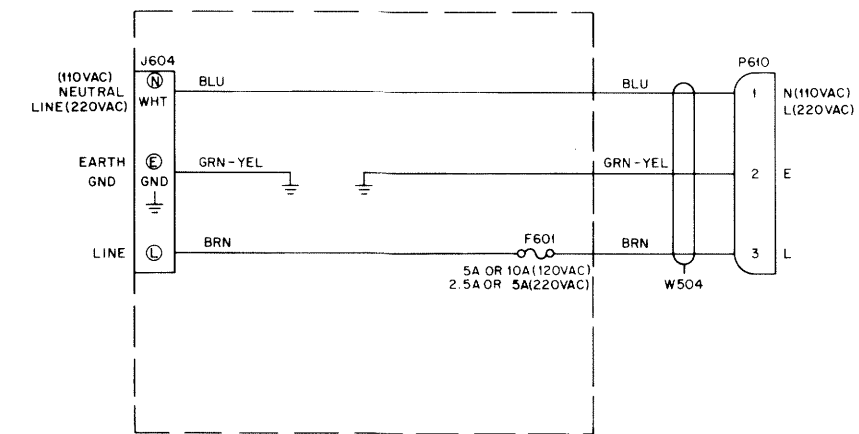

## FUNCTION

Provides interconnections between station and antenna(s), ac or dc power, and provides a location for installation of 2- or 4-wire control wirelines.

## INTERCONNECT DETAILS

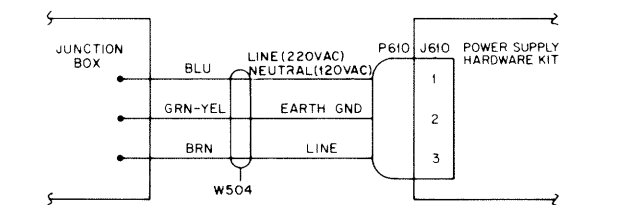
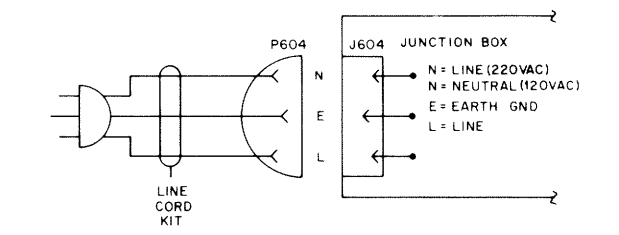

CEPS-37853-0

# JUNCTION BOX

MODEL TRN5350A/51A

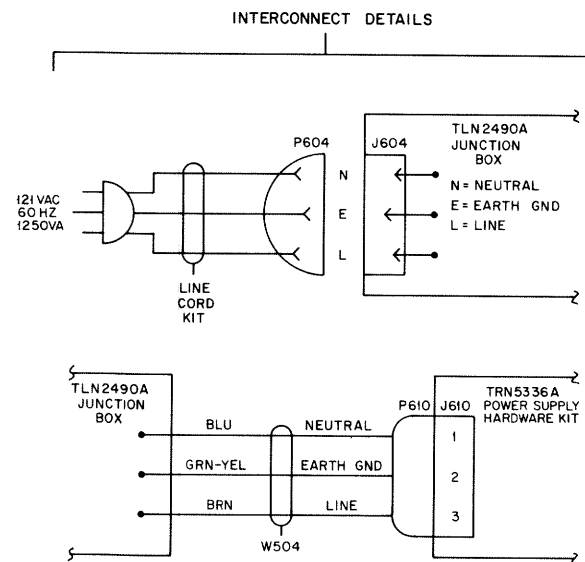
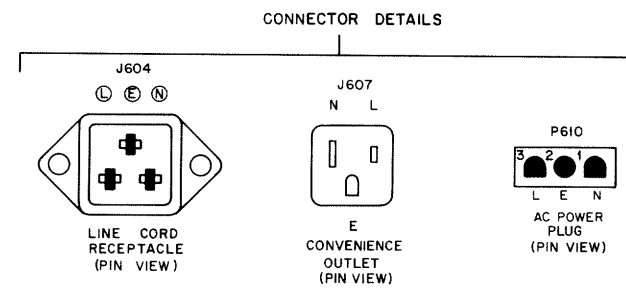
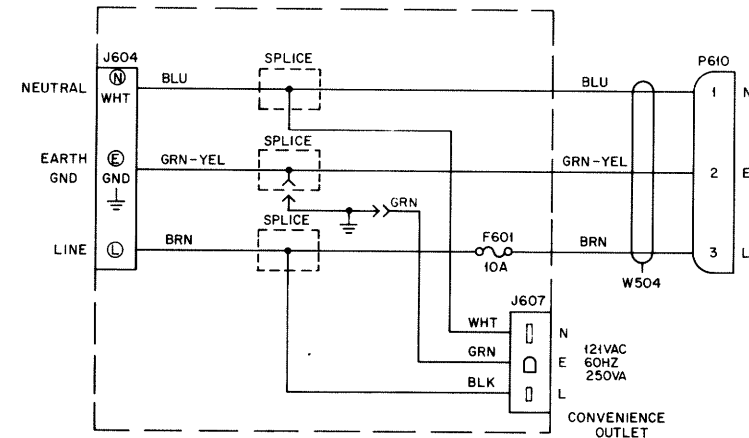

CEPS-35340-0

## parts list

TRN5350A Junction Box, Basic  
 TRN5351A Junction Box, Fully Optionable PL-8035-C

| REFERENCE SYMBOL  | MOTOROLA PART NO. | DESCRIPTION   |
|---|-------------------|---|
| J611  | 15-82889N01       | <b>connector, receptacle:</b><br>HOUSING, 3-contact, power cord |
| J612  | 1-80758D49        | ac outlet w/lug assembly includes:                              |
|   | 9-83238C01        | OUTLET, ac; 3-prong   |
|   | 29-85911B         | LUG, fasten   |
| P610  | 15-83183N01       | <b>connector, plug:</b><br>HOUSING, 3-contact                   |
| <b>mechanical parts</b>   |                   |   |
|   | 2-10971A16        | NUT, machine: M3 x 0.5; 2 used                                  |
|   | 2-10971A18        | NUT, machine: M5 x 0.8; 2 used                                  |
|   | 3-83497N02        | SCREW, machine: M5 x 0.8 x 12                                   |
|   | 3-83497N04        | SCREW, machine: M3 x 0.5 x 8; 1 used                            |
|   | 3-10943M10        | SCREW, tapping: M3 x 0.5 x 8; 2 used                            |
|   | 3-83498N10        | SCREW, tapping: M3.5 x 0.6 x 8; 2 used                          |
|   | 4-7650            | LOCKWASHER, #4 internal; 2 used                                 |
|   | 9-82845L01        | CONNECTOR, crimp; 2 used  |
|   | 9-83358N01        | CONNECTOR, wire splice  |
|   | 15-82835N01       | COVER, junction box   |
|   | 15-82891N01       | HOUSING, fuse with mounting hardware                            |
|   | 29-10228A06       | TERMINAL, connector   |
|   | 37-106352         | GROMMET   |
|   | 39-83145N01       | CONTACT, plug: (part for P610); 2 used                          |
|   | 39-83145N02       | CONTACT, plug: (part for P610)                                  |
|   | 39-83384N01       | CONTACT, plug: (part for J11); 3 used                           |
|   | 42-10217A02       | CLIP, cable; 3 used   |
|   | 42-82143C01       | CLIP, cable; 3/16"  |
|   | 15-82834N04       | HOUSING, interconnect (TRN5350A)                                |
|   | 15-83834N05       | HOUSING, interconnect (TRN5351A)                                |
|   | 3-83497N07        | SCREW, machine slotted; 2 used                                  |
| <b>TRN5452A Hardware and Label Kit (60 Hz) <span style="float: right;">PL-8242-A</span></b> |                   |   |
| REFERENCE SYMBOL  | MOTOROLA PART NO. | DESCRIPTION   |
| F601  | 65-138179         | <b>fuse:</b><br>10 amp; 250 V                                   |
| <b>mechanical parts</b>   |                   |   |
|   | 13-813618         | DECAL, patent no.   |
|   | 33-83748N01       | NAMEPLATE   |
|   | 38-82892N01       | CAP. fuse housing; GRY  |
|   | 54-850440         | LABEL, FCC  |
|   | 54-83040C01       | LABEL, audio  |
|   | 54-83918N01       | LABEL, interconnect housing outlet                              |
|   | 54-83919N01       | LABEL, interconnect housing, fuse                               |
|   | 54-83922N01       | LABEL, as pwr interconnect                                      |
|   | 54-84126C01       | LABEL, replacement parts  |
| <b>TRN5427A Power Cord 110 V <span style="float: right;">PL-8043-O</span></b>               |                   |   |
| REFERENCE SYMBOL  | MOTOROLA PART NO. | DESCRIPTION   |
|   | 30-82933N01       | LINE CORD; with plug and receptacle                             |



*Receiver Model Table*

| Model    | Frequency (MHz) | Description                                | Application  |
|----------|-----------------|--|--|
| TRD6291A | 132-150.8       | Multi-Frequency 10.7 MHz I-F, Non-Filtered | Used with Single Receiver Stations                           |
| TRD6292A | 146-174         |  |  |
| TRD6301A | 132-150.8       | Multi-Frequency 10.7 MHz I-F, Filtered     | Used with 2-Receiver Stations and Repeater Stations          |
| TRD6302A | 146-174         |  |  |
| TRD6311A | 132-150.8       | Multi-Frequency 10.8 MHz I-F, Filtered     | Used with 2 Receiver Stations Where Shifted I-F is Required. |
| TRD6312A | 146-174         |  |  |

**SPECIFICATIONS**

|   |   |  |   |
|---|---|--|---|
| Input Impedance                             | 50 ohms   |  |   |
| Number of Channels                          | 1, 2, 3, or 4   |  |   |
| Frequency Separation                        | 2.0 MHz   |  |   |
| I-F Frequency                               | 10.7 MHz or 10.8 MHz  |  |   |
| EIA Modulation Acceptance                   | ± 7 kHz Minimum   |  |   |
| Frequency Stability                         | ± .0005% from -30°C to +60°C ambient (+ 25°C reference)<br>± .0002% Optional* |  |   |
| Channel Spacing                             | 20 kHz, 25/30 kHz   |  |   |
| Sensitivity:<br>20 dB Quieting<br>EIA SINAD | Less Than<br>Less Than  | <u>With Preamp**</u><br>.25 uV<br>.20 uV | <u>Without Preamp</u><br>.50 uV<br>.35 uV |
| Selectivity:<br>EIA SINAD                   | 20 kHz Channel<br>25/30 kHz Channel   | 85 dB<br>95 dB                           | 90 dB<br>100 dB                           |
| Intermodulation:<br>EIA SINAD               | 20 kHz Channel<br>25/30 kHz Channel   | 75 dB (Minimum)<br>80 dB (Minimum)       | 80 dB (Minimum)<br>85 dB (Minimum)        |
| Spurious and Image Rejection                |   | 100 dB (Minimum)                         | 100 dB (Minimum)                          |

\*\* Available with option C621, C622, C623, C624.

\*\* Optional Model HLD4050A RF Preamp.

**1. DESCRIPTION**

**1.1** These receivers are fully transistorized units that receive FM signals on one to four crystal-controlled frequencies. In a multi-frequency receiver, only one frequency can be received at a time.

**1.2** Each receiver includes an rf preselector, mixer, local oscillator injection circuitry, high gain selective i-f

stages, quadrature detector, audio preamplifier, and a low-ripple 9.5 volt regulator. The receiver develops a low noise audio signal from a frequency modulated "on-channel" rf carrier in the 132-174 MHz range. An optional rf preamplifier may be used with any of these receivers.

**1.3** All circuits are constructed on a single plug-in circuit board which is easily accessible for servicing. The

**technical writing services**

1301 E. Algonquin Road, Schaumburg, IL 60196

receiver plugs into the backplane interconnect board which provides all dc, audio, and rf connections thereby eliminating all interconnecting wiring. All alignment points are accessible through the top of the rf compartment cover.

## 2. THEORY OF OPERATION

### 2.1 PI FILTER, RF PRESELECTOR, OPTIONAL PREAMPLIFIER

The receive port of the antenna switch is connected to the 5 cavity helical resonator rf preselector through the input "pi" filter. The "pi" filter, consisting of C135, C136, and L112, provides additional filtering for higher frequency spurious responses. The steep skirted rf preselector filter has a bandwidth of 2.0 MHz and ultimate rejection of 100 dB. To provide additional front-end selectivity while minimizing loss, the optional rf preamplifier is inserted in the housing between the second and third cavities. The output of the preselector (L5) is connected to the gate of N-channel JFET mixer, Q103.

### 2.2 LOCAL OSCILLATOR INJECTION CIRCUITRY

Plug in crystal oscillator modules (channel elements) provide a stable, temperature compensated frequency which is applied to injection amplifier Q101. Each receiver is capable of receiving up to four distinct frequencies. The output of Q101 (typical gain of 15 dB) passes through a two pole bandpass filter which attenuates unwanted harmonics of the injection frequency. The injection level of +12 dBm (typical) is coupled to the source of mixer Q103.

### 2.3 MIXER

Excellent intermodulation immunity is provided by a JFET mixer, Q103. The filtered receive input and injection signal are applied to the gate and source respectively. The output at the drain is applied to impedance matching circuitry which emphasizes the difference frequency applied to the i-f circuitry. Both the mixer and the following impedance matching circuitry are shielded.

### 2.4 I-F CIRCUITRY

**2.4.1** Several stages of filtering and amplification are employed in the i-f circuitry. Selective i-f filtering is accomplished using dual-resonator, mode coupled monolithic crystals cut to a fundamental frequency of 10.7 MHz or 10.8 MHz. Due to the inherent piezoelectric properties of the crystal material, input signals selectively produce mechanical vibrations which propagate through the device. At the output the same piezoelectric property selectively converts the mechanical vibrations into the i-f electrical signal.

**2.4.2** Refer to Figure 1. The high "Q" of the crystals create steep skirts which result in excellent on-channel intelligibility and off-channel signal rejection. The i-f circuitry requires no tuning and makes extensive use of shielding.

**2.4.3** The first crystal filter is a single 2-pole device, Y201. This stage is followed by a matching network, 16 dB discrete amplifier Q201, additional matching, and 4-pole filter Y202-Y203. The output of the first 4-pole filter is applied to a matching network and then to high gain (approximately 50 dB) 2nd i-f amplifier U201. The output of U201 is applied to matching circuitry, a 2nd 4-pole filter Y204-Y205, final matching circuitry, and limiter/detector U202.

### 2.5 LIMITER/DETECTOR

Limiter/Detector U202 is a 16-pin monolithic integrated circuit that internally includes three stages of i-f amplification for limiting, a quadrature fm detector, audio preamplifier, and alignment metering output. The recovered audio output of approximately 500 mV is applied to audio buffer amplifier Q202, which provides the 250 mV receiver detected audio level required by the R1 (or R2) audio board in the control package.

### 2.6 9.5 VOLT REGULATOR

The regulated 9.5 volts and 13.8 volts provided to the receiver from the station power supply are applied to Q104 and Q105, resulting in a highly regulated and filtered 9.5 volts. This highly regulated 9.5 volts is supplied to the receiver channel elements, quadrature detector U202, and audio preamplifier Q202 to assure good receiver hum and noise performance.

### 2.7 DELAYED KEYED A +

This circuit (Q102) provides for disabling of the receiver channel element while the base station is in the transmit mode and prevents audio feed back to the receiver.

## 3. MAINTENANCE

Malfunctions in the receiver can be localized by using the optional built-in station metering kit or connecting a Motorola portable test set to the receiver metering receptacle and making stage measurements. The meter readings may be compared to the values shown on the receiver functional diagram, but preferably, a log of readings should be maintained for reference. Each new set of readings should then be compared to previous readings. An abrupt change in a meter reading indicates a circuit failure while a gradual change in a reading may indicate an impending failure which can be corrected before operation becomes marginal. Refer to the Receiver Maintenance section for further information.

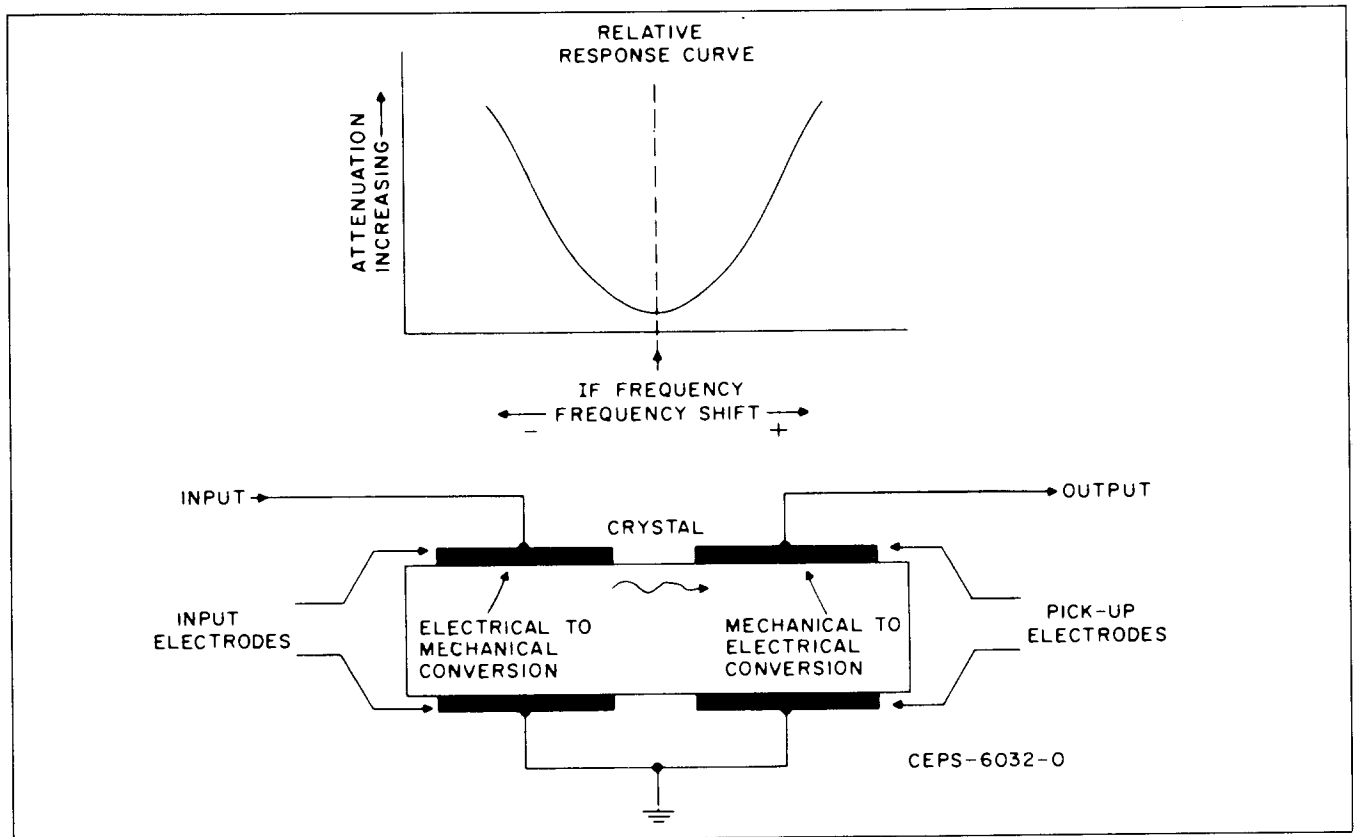

Figure 1. Simplified Piezoelectric Coupling Diagram

## 4. RECEIVER FUNCTIONAL TESTS

### 4.1 AUDIO AND SQUELCH TEST

The receiver and R1 audio board should provide 1.0 watts of audio when the VOLUME control on the R1 audio board is set fully clockwise and a strong carrier signal is received that is modulated  $\pm 3.0$  kHz deviation with a 1000 Hz tone. When the rf input signal is reduced to minimum and the SQUELCH control on the R1 audio board is set at threshold, the speaker should be quieted. Increasing the rf input signal a small amount should again produce noise in the speaker. On *Private-Line* models, no signal should be heard from the speaker unless the signal has the proper PL tone modulation. These circuits may be checked as follows:

Step 1. PL disable station. Connect speaker to test connector on mother board. Adjust the signal generator for 1000  $\mu$ V input to the receiver modulated with 1000 Hz tone for  $\pm 3.0$  kHz deviation.

Step 2. Connect an ac voltmeter to measure the voltage between pins 1 and 2 of the control metering socket.

Step 3. Set the VOLUME control on the R1 audio board fully clockwise. The ac voltmeter should indicate at least 2.8 volts rms.

Step 4. Decrease the signal generator output to minimum. Remove modulation from signal generator.

Step 5. Set the SQUELCH control at threshold, that is, clockwise until the noise just quiets.

Step 6. Increase the signal generator output slightly until the noise is again heard in the speaker. No more than .125  $\mu$ V should be required.

Step 7. On *Private-Line* radios, enable the PL function. No noise should be heard in the speaker.

Step 8. Modulate the rf signal with the proper *Private-Line* tone with  $\pm 500$  Hz deviation. Adjust signal generator output until noise is again heard in speaker. (See audio section for PL squelch specifications).

## 4.2 20 DB QUIETING TEST

With no signal input and the receiver unquieted, noise should be heard in the speaker or indicated on position 11 of the portable test set (function selector switch in RCVR position). When a carrier frequency signal is injected, the noise should decrease. No more than 0.5 uV (.25 uV if radio is equipped with rf preamplifier) should be required to decrease the noise 20 dB. This may be checked as follows:

Step 1. Unquiet receiver by turning the SQUELCH control on the R1 audio board fully counterclockwise. PL disable the receiver.

Step 2. Set the function selector switch on the portable test set to the RCVR position and the selector switch to position 11.

Step 3. Adjust VOLUME control on the R1 audio board for noise in the speaker and a reading on the test set meter. A reading of 1.5 V ac is a convenient reference value to use.

Step 4. Connect an rf signal generator (set to the receiver carrier frequency) to the antenna input connector.

Step 5. Beginning with minimum signal level, increase the signal generator output until the meter 11 reading drops to 1/10 the reference value in Step 3, that is 0.15 V ac. No more than 0.5 microvolt output from the signal generator should be required to quiet the receiver.

## 4.3 RECEIVER GAIN MEASUREMENTS

### NOTE

Before making any receiver gain measurements, make sure the case of every crystal filter has a good conductive path to ground. A continuity test should indicate less than 1 ohm between the crystal filter case and the receiver circuit board ground plating. A bad ground connection may cause errors in gain measurements.

Step 1. Proper receiver alignment is essential to this procedure portion of the Station Alignment. Perform a complete receiver alignment as given in the "Receiver Alignment" section of this manual.

Step 2. Refer to the Receiver Functional Block Diagram, receiver schematic diagram, and the receiver circuit board detail diagram while performing this procedure.

Step 3. Adjust the rf signal generator output frequency to the receive channel frequency. Adjust the rf signal generator output to provide the required receiver input voltage for a particular test point. Then, using an

rf ac voltmeter, measure the rf signal voltage between the test point and a nearby chassis ground point. At every test point, the measured voltage should be within  $\pm 6$  dB of the given value.

## 5. TROUBLESHOOTING TECHNIQUES

### 5.1 VISUAL INSPECTION

The first step in the troubleshooting procedure should be a thorough visual inspection of the receiver and, in particular, the receiver board. Corrosion, burned or damaged components are usually easily seen and may be the cause or a symptom of the receiver malfunction. An improperly installed receiver shield can cause a degradation in receiver performance.

After the "obvious" problems have been corrected, repeat the receiver board performance tests. If the tests still produce unsatisfactory results, refer to the receiver troubleshooting chart in this section. The troubleshooting chart provides a systematic procedure for isolation of the defective stage and component.

As much information as possible has been included on the troubleshooting chart. However, it will be necessary to occasionally refer to the receiver schematic diagram and circuit board detail. Detailed procedures regarding alignment as a troubleshooting technique, integrated circuit troubleshooting, receiver gain measurements, and crystal troubleshooting follow in the remaining paragraphs of this section.

### 5.2 ALIGNMENT AS A TROUBLESHOOTING TECHNIQUE

Low meter readings, and otherwise abnormal performance of the receiver are very often corrected by realignment. Therefore, alignment should be one of the first troubleshooting steps performed for these symptoms.

### 5.3 TROUBLESHOOTING INTEGRATED CIRCUITS

Integrated circuits (IC) are very reliable components and should not be replaced unless it is definitely indicated that the IC is the defective component. Before replacing an IC, make sure that the external components in the circuit are normal. The IC's on the receiver board may be checked by dc voltage measurements. Refer to schematic diagram for correct voltages.

### 5.4 TROUBLESHOOTING CRYSTALS

A defective filter crystal can best be found by performing an i-f gain check per the schematic diagram. A defective crystal will show an abnormally high insertion loss. If the crystal is found to be defective because of high insertion loss or an ungrounded case, it should be replaced.



# VHF RECEIVER

MODEL SERIES TRD6290A, TRD6300A,  
AND TRD6310A

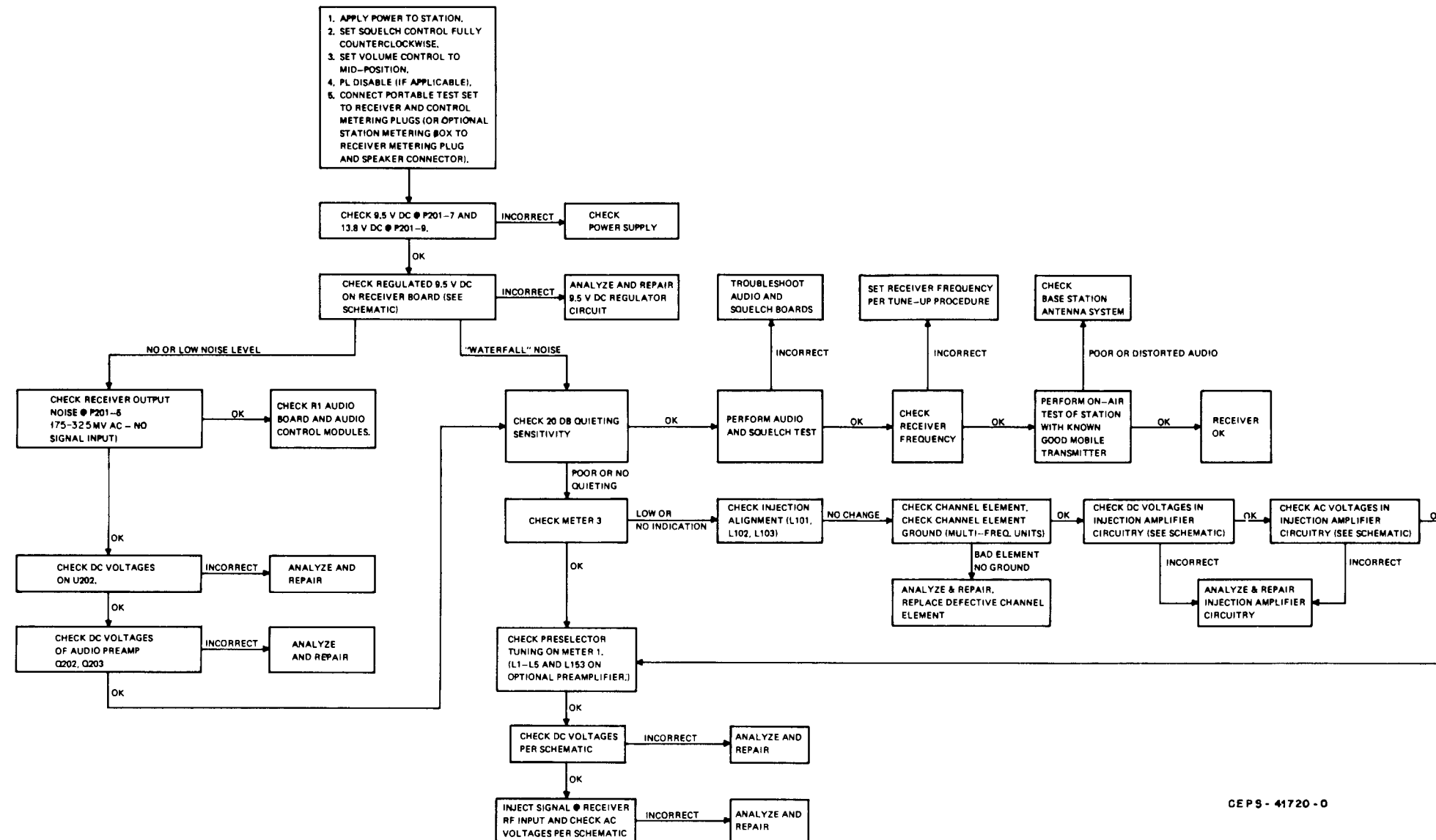

CEPS - 41720 - 0

# VHF RECEIVER

MODEL SERIES TRD6290A, TRD6300A,  
AND TRD6310A

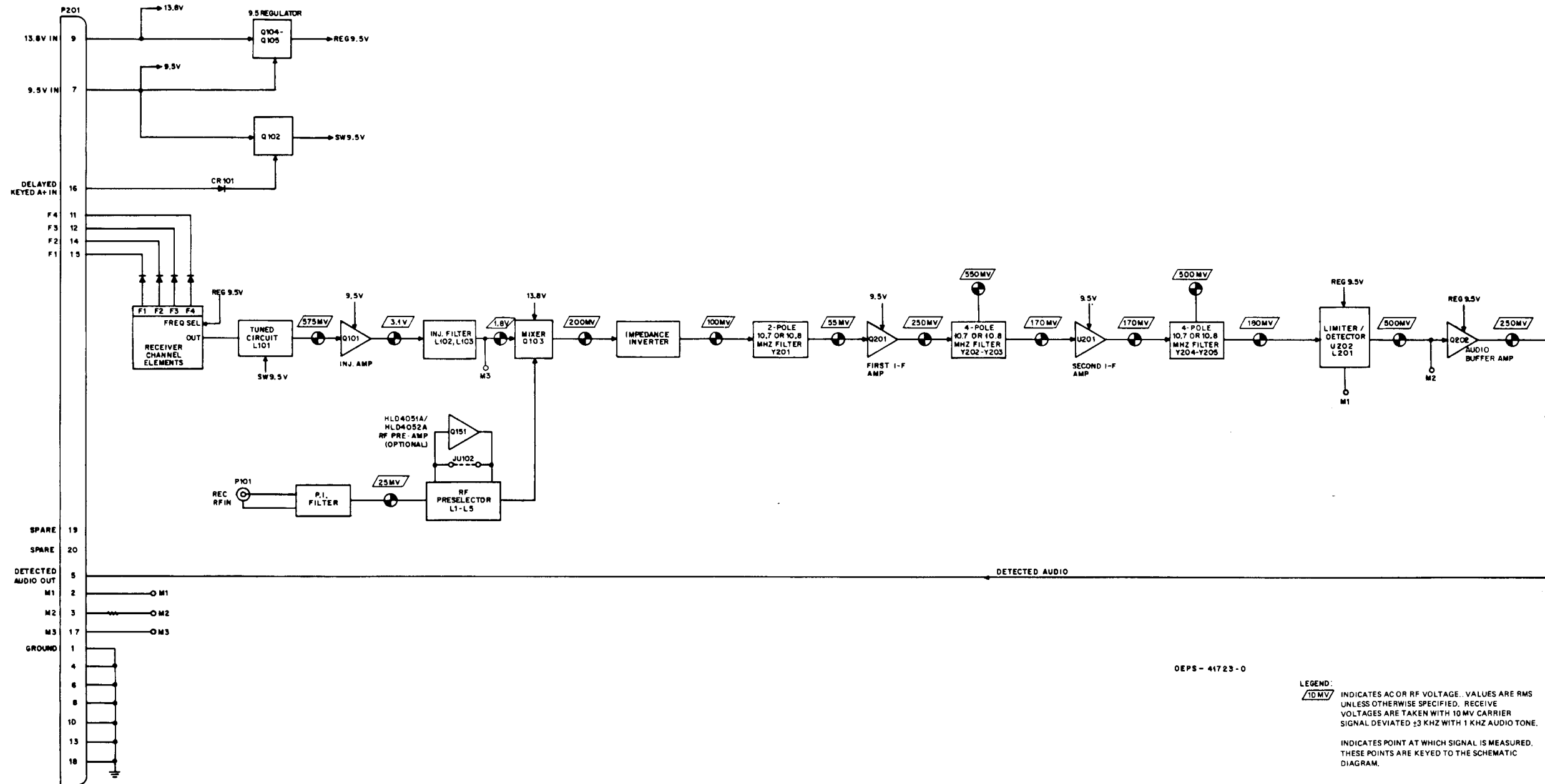

| REQUIRED TEST EQUIPMENT FOR VHF RECEIVER SERVICING |   |   |  |
|--|---|---|--|
| General Type                                       | Application   | Recommended Model   | Minimum Specifications   |
| AC-DC VOM  | DC voltage measurements, general  | Motorola T1009  | Measurement range: 0-15 V dc<br>Sensitivity: 20,000 ohms/volt  |
| DC Multimeter                                      | DC voltage readings requiring a high input resistance meter                 | Motorola S1063  | Measurement range: 0-15 V dc<br>Input resistance: 11 megohms   |
| AC Voltmeter                                       | Audio voltage measurements  | Motorola S1053  | Measurement range: 0-10 V ac<br>Input resistance: 10 megohms   |
| RF Voltmeter                                       | RF voltage measurements   | Motorola S1339  | Measurement range: 100 uV-3 V from 1 MHz-512 MHz<br>Inputs: 50 ohm and high impedance  |
| Oscilloscope                                       | Waveform observation  | Motorola R1004  | Vertical sensitivity: 5 mV-10 V/division<br>Horizontal time base: 0.2 usec.<br>0.5 sec/division  |
| Frequency Meter                                    | Receiver frequency measurement  | Model R1200 Service Monitor with high stability oscillator (X suffix) option.<br>Frequency calibration recommended every 6 months or less.      | Measurement range: 134-174 MHz<br>Frequency resolution: 10 Hz  |
| RF Signal Generator                                | Receiver alignment and troubleshooting                                      | Motorola R1200 Service Monitor with attenuator  | Frequency range: 134-174 MHz<br>Output Level: 0.1 uV-100,000 uV<br>Must be capable of at least $\pm 3$ kHz deviation when modulated by 1 kHz tone. |
| Audio Signal Generator                             | Audio circuit troubleshooting   | Motorola S1067  | Frequency range: 20 Hz-20 kHz<br>Output level: 50 mV-1 V   |
| PL Tone Generator*                                 | Tone-coded Private-Line decoder troubleshooting                             | Motorola S1333  | Frequency range: 10 Hz-9999 Hz<br>Output level: 0-3 V rms  |
| DPL Test Set**                                     | Digital Private-Line encoder-decoder troubleshooting                        | Motorola SLN6413  |  |
| Radio Test Set                                     | Meter readings at circuit metering points for alignment and troubleshooting | Motorola S1056 Portable Test Set with a TEK-37 or TEK-37A Test Set Adapter or a Motorola TEK-5 Meter Panel with a TEK-40 (MICOR Adapter) Cable. |  |
| DC Power Supply                                    | DC power for shop service   | Motorola R1011  | 1-20 V dc<br>0-40A   |

\*Required for tone-coded Private-Line models only.  
\*\*Required for Digital Private-Line models only.

**NOTE**

All test equipment, with the exception of the DPL test set and dc power supply, may be replaced by the Motorola R2001 System Analyzer. Tuning tools Motorola Part No. 66-82977K01 and 66-83398A01 are to be used for alignment purposes.

**RECEIVER FREQUENCY CALCULATIONS**

Where

$f_o$  = channel element frequency  
 $f_c$  = carrier frequency  
 $f_{inj}$  = injection frequency

10.7 MHz I-F Receivers

$$f_{inj} = f_c - 10.7 \text{ MHz}$$

$$f_o = \frac{f_c - 10.7 \text{ MHz}}{3}$$

10.8 MHz I-F Receivers

$$f_{inj} = f_c - 10.8 \text{ MHz}$$

$$f_o = \frac{f_c - 10.8 \text{ MHz}}{3}$$

**VHF RECEIVER ALIGNMENT PROCEDURE**

The tuning procedure should be performed using the Motorola S1056 portable Test Set. Connect metering cable to receiver metering socket on rear of interconnect board. Place the A/B switch in the A position and the FUNCTION SELECT switches to the RCVR position and meter reverse position. If using the TEK5-F or modified TEK5-B through TEK5-E meter panels, put the function switch to position C and the M1, 2 switch to the normal position. If using the optional station metering box, put the FORWARD-REVERSE switch in the FORWARD position.

**NOTE**

For units containing two receivers, align each receiver individually using this same procedure.

| Step | Meter Position              | Adjust  | Procedure  |
|------|-----------------------------|---|--|
| 1    |                             | L1-L5   | Preset the rf preselector tuning screws per the coil preset chart.   |
| 2    |                             | L101, L102, L103                                | Preset the injection string coil slugs per the coil preset chart.  |
| 3    |                             |   | Perform Step 3A for radios with maximum receive frequency separation of 0.5 MHz or less; perform Steps 3B and 3C for radios with maximum receive frequency separation greater than 0.5 MHz   |
| 3A   | 3                           | L103, L102, L101                                | Adjust the injection string coils for peak reading on meter 3 with lowest frequency selected. Repeat until no further improvement is obtained.   |
| 3B   | 3                           | L103, L102, L101                                | Adjust the injection string coils for peak reading on meter 3 with highest frequency selected. Repeat until no further improvement is obtained. Tune L103 for peak meter 3 reading with lowest frequency selected. Repeat L101 and L102 for peak on highest frequency and L103 on lowest frequency until no further improvement is obtained.   |
| 3C   | 3                           | L102  | If meter 3 reading on lowest frequency is less than meter 3 reading on highest frequency, increase meter 3 reading on lowest frequency by adjusting L102 for best balanced reading.  |
|      |                             | L103  | If meter 3 reading on highest frequency is less than meter 3 reading on lowest frequency, increase meter 3 reading on the highest frequency by adjusting L103 for best balanced reading. Make sure the frequency reading does not drop below the highest frequency reading.  |
| 4    | 1                           | L1-L5 (and L153 on optional preamp)             | Adjust L1, L2, (L153), L3, L4, L5 in order for peak reading on meter 1 using the highest frequency and maintaining meter 1 between 30 and 40 uA by adjusting the signal generator output. Repeat until no further improvement is obtained.   |
|      |                             |   | Perform Step 7 only for radios with maximum receive frequency separation greater than 0.5 MHz.   |
| 5    | 1                           | L1-L5 (and L153 on optional preamp)             | Adjust L1, L2, (L153), L3, L4, L5 once in that order for peak reading on meter 1 using the lowest frequency and maintaining meter 1 between 30 uA and 40 uA by adjusting the signal generator output.  |
| 6    | Audio zero beat (See Note)  | Channel Element                                 | For each frequency, set rf generator to the carrier frequency ( $\pm 75$ Hz) without modulation. With a wire connected to a 1 mV, 10.7 MHz (or 10.8 MHz for receivers with shifted i-f frequency) signal source, "spray" the signal near Q201. Warp channel element for audio zero beat.<br>Perform Step 7A for radios with maximum receive frequency separation of 0.5 MHz or less; perform Step 7B for radios with maximum receive frequency separation greater than 0.5 MHz |
| 7A   | AC Voltmeter across speaker | L5 (or L1 and L2 on rcvr. with optional preamp) | Adjust L5 (or L1 and L2 in Preamp Radios) for best quieting with the highest frequency selected. Receiver tuning is now complete.  |
| 7B   | AC Voltmeter across speaker | L1-L5 (Do not adjust L153 on optional preamp)   | Check 20 dB quieting sensitivity on all frequencies. If necessary, retune L1 and L2 once on highest frequency for best quieting. Check sensitivities again and if necessary retune L3-5 once, on the lowest frequency, for best quieting. Receiver tuning is now complete.   |

Note: Alternate Method of Setting Receiver Oscillator Frequency Using a Frequency Counter.

"Sniff" the injection frequency in the following manner: Connect a coax cable which has 1 to 2 inches of ground shield removed from one end to the frequency counter. Insert this end into coil form L103 in the receiver injection circuit. This should provide enough signal to accurately gate the counter. For each frequency, adjust the receiver channel element for the injection frequency  $\pm 75$  Hz. (Calculate injection frequency using appropriate formula at beginning of alignment procedure.)

**RECEIVER METER READINGS**

When the receiver is properly aligned, meter deflections should fall within the following limits. Where two numbers are given, the readings are non-preamp/preamp.

| Switch Position           | Meter 1                          | Meter 2                    | Meter 3            |
|---------------------------|----------------------------------|----------------------------|--------------------|
| Meter Reading (no signal) | 12/14 uA (min)<br>30/32 uA (max) | 20 uA (min)<br>30 uA (max) | 10 uA (min)        |
| Function Metered          | Limiter/Detector                 | Detector Alignment         | Receiver Injection |

**Coil Preset Charts**

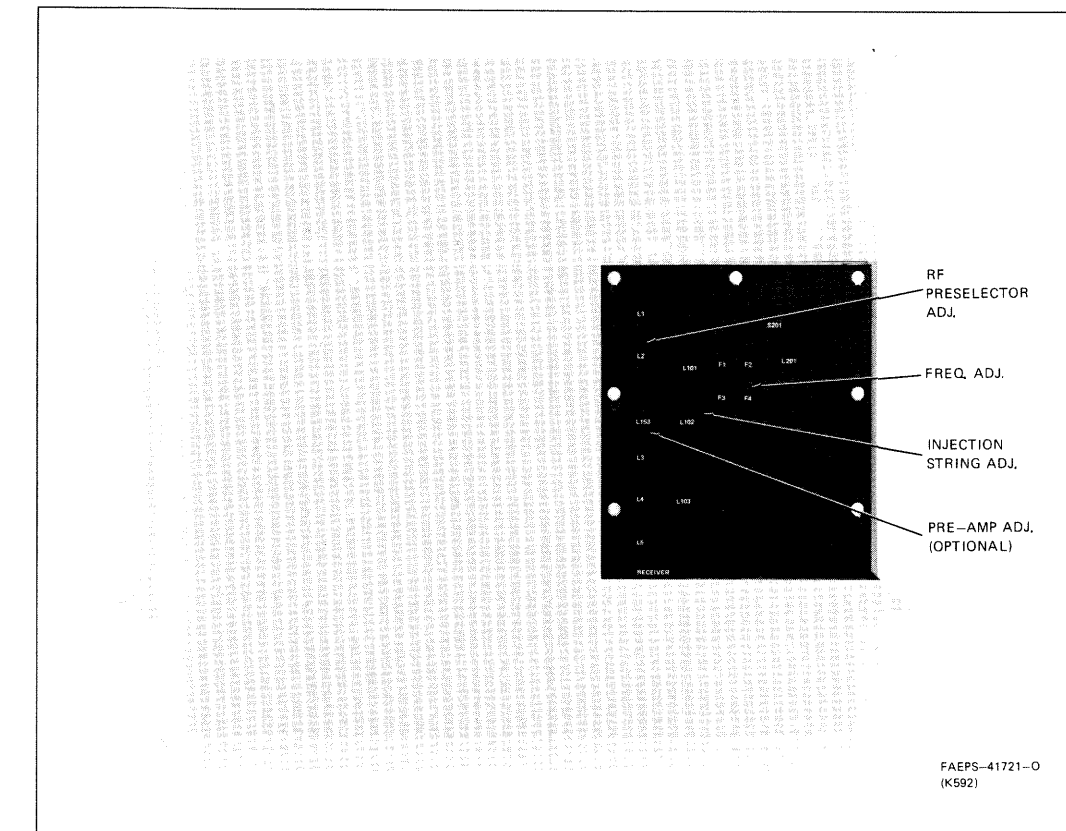
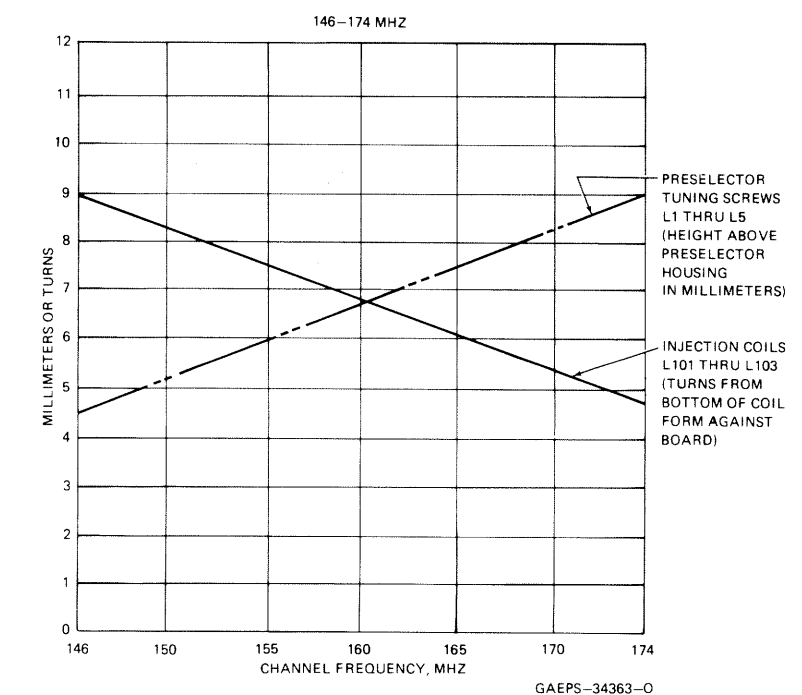
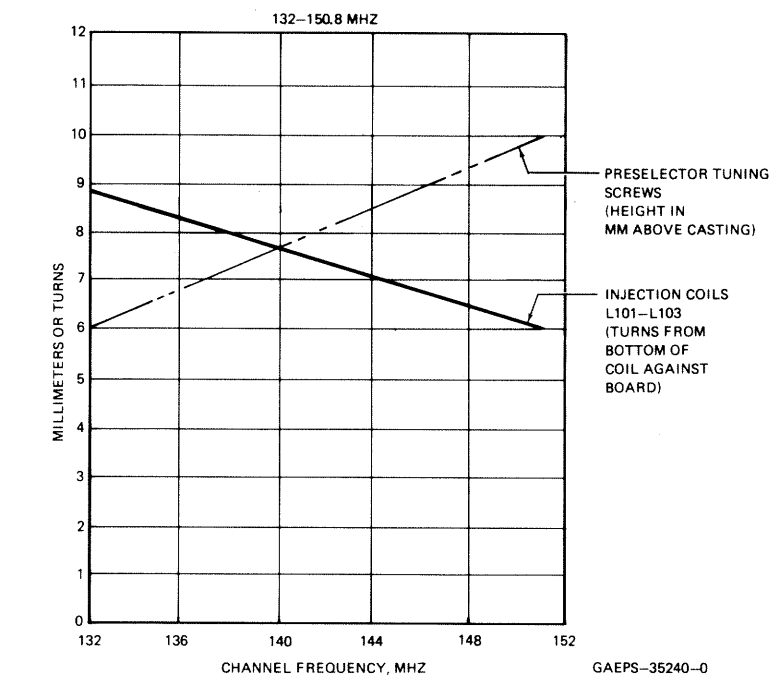

Figure 2. Receiver Alignment Adjustment Locations

**VHF RECEIVER**  
 MODEL SERIES TRD6290A, TRD6300A,  
 AND TRD6310A

**parts list**

TRD6291A, TRD6292A 10.7 MHz I-F Receiver, Non-Filtered  
 TRD6301A, TRD6302A 10.7 MHz I-F Receiver, Filtered  
 TRD6311A, TRD6312A 10.8 MHz I-F Receiver, Filtered PL-9667-C

| REFERENCE SYMBOL | MOTOROLA PART NO. | DESCRIPTION  |
|------------------|-------------------|--|
| C101             | 21-11021H06       | capacitor, fixed: pF ± 5%; 50 V; unless otherwise stated |
| C102L            | 21-82204B31       | .033 uF + 80-20%   |
| C102H            | 21-82204B75       | 8.0 ± 0.25 pF  |
| C103L            | 21-11022G12       | 5.6 ± 0.25 pF  |
| C103H            | 21-11022G08       | 3 ± 0.25 pF  |
| C104             | 21-11022G37       | 2 ± 0.25 pF  |
| C105             | 21-11021H06       | 20   |
| C106             | 21-11021E05       | .033 uF + 80-20%   |
| C107             | 21-11021H06       | 220 ± 10%  |
| C108             | 21-11021E05       | .033 uF + 80-20%   |
| C109L            | 21-11022H29       | 220 ± 10%  |
| C109H            | 21-11022H23       | 12   |
| C110L            | 21-842041         | 8.1 ± 0.5 pF; N150                                       |
| C110H            | 21-82450B26       | 0.36   |
| C111L            | 21-11022H29       | 0.3 ± 10%; 500 V   |
| C111H            | 21-11022H23       | 8.2 ± 0.5 pF; N150                                       |
| C112             | 21-11022G12       | 3 ± 0.25 pF  |
| C113             | 21-11021E05       | 220 ± 10%  |
| C115             | 21-11021H06       | .033 uF + 80-20%   |
| C116             | 21-11021E05       | 220 ± 10%  |
| C117L            | 21-11014H13       | 3.3 ± 0.25 pF  |
| C117H            | 21-11022G08       | 2 ± 0.25 pF  |
| C118             | 21-11021H06       | .033 uF + 80-20%   |
| C119             | 21-11022G50       | 68   |
| C120             | 21-11021E05       | 220 pF ± 10%   |
| C121             | 23-11019A21       | 10 uF ± 20%; 35 V  |
| C122             | 21-82989E17       | 7 ± 0.25 pF; 500 V                                       |
| C123             | 21-83406D84       | 5.6 ± 0.25 pF  |
| C124             | 21-82989E21       | 9 ± 0.25 pF; 500 V                                       |
| C125             | 23-11019A46       | 100 uF ± 20%; 25 V                                       |
| C126             | 21-11021H06       | .033 uF + 80-20%   |
| C127, 128        | 23-11019A46       | 100 uF ± 20%; 25 V                                       |
| C129             | 21-11021H06       | .033 uF + 80-20%   |
| C130 thru 133    | 21-11021E05       | 220 ± 10%  |
| C135, 136        | 21-11022G34       | 15   |
| C201             | 21-82450B07       | 0.39; 500 V  |
| C202             | 21-11022G45       | 43   |
| C203             | 21-11022G40       | 27   |
| C204 thru 207    | 21-11021H06       | .033 uF + 80-20%   |
| C208             | 21-11022G44       | 30   |
| C209             | 21-11022G41       | 30   |
| C213             | 21-82450B44       | 0.82; 500 V  |
| C216             | 21-11022G40       | 27   |
| C217             | 21-11022G45       | 43   |
| C218 thru 222    | 21-11021H06       | .033 uF + 80-20%   |
| C223             | 21-11014H42       | 51; 100 V  |
| C224             | 21-11022G38       | 22   |
| C225             | 21-11022G39       | 24   |
| C226             | 21-82450B44       | 0.82; 500 V  |
| C227             | 21-82450B17       | 2.2; 500 V   |
| C231             | 21-11022G41       | 30   |
| C232             | 21-11022G44       | 39   |
| C233 thru 235    | 21-11021H06       | .033 uF + 80-20%   |
| C236             | 21-11022G17       | 4.7 uF ± 0.25  |
| C237             | 21-11022G25       | 8 uF ± 0.5   |
| C238             | 21-11022G31       | 11 uF ± 5%   |
| C241             | 21-11021H06       | .033 uF ± 5%   |
| C242             | 21-11021H06       | .033 uF + 80-20%   |
| C243             | 21-11021E21       | .0047 uF ± 10%   |
| C244             | 8-11017A08        | .0047 uF ± 5%  |
| C247             | 23-11019A27       | 22 uF ± 20%; 25 V  |
| C248 thru 260    | 21-11021E13       | 1000 (TRD6182A, 6192A)                                   |
| CR101            | 48-83654H01       | diode: (see note)  |
| CR102            | 48-82139G01       | silicon  |
| CR103 thru 110   | 48-83654H01       | germanium  |
| CR111            | 48-83654H02       | silicon  |
| J103             | 28-80181B01       | connector, plug:   |
| J104 thru 107    | 28-80096A01       | male; 6-contact  |
| L11              | 24-80032A07       | coil, rf:  |
| L1H              | 24-80032A02       | helical; VIO   |
| L2L              | 24-80032A08       | helical; RED   |
| L2H              | 24-80032A03       | helical; BRN   |
| L3L              | 24-80032A09       | helical; GRN   |
| L3H              | 24-80032A05       | helical; NAT   |
| L4L              | 24-80032A06       | helical; BLU   |
| L4H              | 24-80032A01       | helical; NAT   |
| L5L              | 24-80032A10       | helical; BLU   |
| L5H              | 24-80032A04       | helical; YEL   |
| L101, 102        | 24-80065A01       | 4-1/2 turns; coded RED                                   |
| L103             | 24-80065A03       | 4-1/2 turns; coded YEL                                   |
| L104, 105        | 24-82548D29       | choke; 1.8 uH  |
| L106             | 24-82723H04       | choke; 0.29 uH   |
| L107             | 24-83884G12       | 117 nH (8-1/2 turns); coded RED                          |
| L108             | 24-82835G11       | choke; 3.5 uH  |
| L109             | 24-83961B02       | 5 turns; coded GRN                                       |
| L110             | 24-83397L11       | choke; 30 uH   |
| L111             | 24-83397L08       | choke; 15 uH   |
| L112             | 24-83884G08       | 73 nH; 5-1/2 turns; coded ORG                            |

| REFERENCE SYMBOL        | MOTOROLA PART NO. | DESCRIPTION   |
|-------------------------|-------------------|---|
| L202                    | 24-83397L07       | choke; 10 uH  |
| L203                    | 24-82723H03       | choke; 23 uH  |
| L204, 205               | 24-83397L07       | choke; 10 uH  |
| L206                    | 24-82723H03       | choke; 23 uH  |
| L207                    | 24-83397L08       | choke; 15 uH  |
| L208                    | 24-83397L07       | choke; 10 uH  |
| L209                    | 24-82723H03       | choke; 23 uH  |
| L210 thru 222           | 24-83961B01       | choke; 3 turns (BRN) (TRN6181A, TRD6182A, TRN6191A, TRD6192A) |
|                         | or 6-11009B23     | resistor jumper (TRN6171A, TRD6172A)                          |
| L230                    | 24-11047B58       | or 10   |
| L231                    | 24-83397L07       | choke; 24 uH  |
|                         | 24-83397L07       | choke; 10 uH  |
| P101                    | 9-82872N01        | connector, receptacle:  |
| P200, P201              | 9-83497F05        | female; 10-contact (2 ea.)                                    |
| Q101                    | 48-869932         | transistor: (see note)  |
| Q102                    | 48-869643         | NPN; type M9932   |
| Q103                    | 48-869639         | PNP; type M9643   |
| Q104                    | 48-869642         | field-effect; type M9839                                      |
| Q105                    | 48-84411L10       | PNP; type M1110   |
| Q201                    | 48-869494         | NPN; type M9494   |
| Q202                    | 48-869643         | PNP; type M9643   |
| R102                    | 6-11009A13        | resistor, fixed: ± 5%; 1/4 W; unless otherwise stated         |
| R103                    | 6-11009A57        | 33  |
| R104                    | 6-11009A45        | 2.2k  |
| R105                    | 6-11009A24        | 680   |
| R106                    | 6-11009A71        | 91  |
| R107                    | 6-11009A73        | 8.2k  |
| R108                    | 6-11009A39        | 10k   |
| R109                    | 6-11009A51        | 390   |
| R110                    | 6-11009A25        | 3.3k  |
| R111                    | 6-11009A81        | 15  |
| R112, 113               | 6-11009A49        | 100   |
| R201                    | 6-11009A79        | 22k   |
| R202                    | 6-11009A49        | 1k  |
| R203                    | 6-11009A87        | 18k   |
| R204                    | 6-11009A37        | 39k   |
| R205                    | 6-11009A11        | 27  |
| R206                    | 6-11009A54        | 330   |
| R207                    | 6-11009A93        | 27  |
| R208                    | 6-11009A35        | 1.6k  |
| R209, 210               | 6-11009A93        | 68k   |
| R211                    | 6-11009A39        | 270   |
| R212                    | 6-11009A41        | 68k   |
| R213                    | 6-11009A41        | 470   |
| R214                    | 6-11009A49        | 1k  |
| R215                    | 6-11009A77        | 15k   |
| R216                    | 6-11009A73        | 10k   |
| R217                    | 6-11009A65        | 4.7k  |
| R219                    | 6-11009A94        | 75k   |
| R220                    | 6-11009A73        | 10k   |
| R221                    | 6-11009B02        | 150k  |
| R222                    | 6-11009A65        | 4.7k  |
| U201                    | 51-83629M05       | integrated circuit: (see note)                                |
| U202                    | 51-83629M60       | second i-f amplifier  |
|                         | 51-83629M60       | quad detector   |
|                         | 51-84561L84       | or quad detector  |
| Y201                    | 91-80011E04       | crystal: (see note)   |
|                         | or 48-84396K07    | 10.7 MHz (TRD6301A, TRD6302A, TRN6291A, TRD6292A)             |
|                         | 91-80011E05       | 10.8 MHz (TRD6311A, TRD6312A)                                 |
| Y202 thru 206           | 91-80011E05       | 10.7 MHz (TRD6301A, TRD6302A, TRN6291A, TRD6292A)             |
|                         | or 48-84396K06    | 10.8 MHz (TRD6311A, TRD6312A)                                 |
| <b>mechanical parts</b> |                   |   |
|                         | 2-80045A01        | NUT, retainer: M5 x 0.8; 5 used                               |

| REFERENCE SYMBOL | MOTOROLA PART NO. | DESCRIPTION                           |
|------------------|-------------------|---------------------------------------|
|                  | 3-3375            | SCREW, tapping; 6-20 x 5/16"; 14 used |
|                  | 3-80012A04        | SCREW, set; 5 used                    |
|                  | 3-84256M01        | SCREW, tapping; 8 used                |
|                  | 5-84220B01        | GROMMET, panel; 8 used                |
|                  | 15-80008A01       | HOUSING                               |
|                  | 26-80062C01       | SHIELD, IC                            |
|                  | 26-80121A01       | SHIELD, can; 5 used                   |
|                  | 26-80144B03       | SHIELD, mixer                         |
|                  | 26-80196A01       | SHIELD, coil; 3 used                  |
|                  | 26-82868N01       | SHIELD, 1st i-f                       |
|                  | 26-82870N01       | SHIELD, input                         |
|                  | 26-84173N01       | SHIELD, mag.                          |
|                  | 26-82871N01       | SHIELD, quad                          |
|                  | 26-83347N01       | SHIELD, 2nd i-f                       |
|                  | 26-83596M01       | SHIELD, antenna                       |
|                  | 26-84243B03       | SHIELD, mixer                         |
|                  | 45-83824N01       | CARD, ejector; 2 used                 |
|                  | 75-05295B01       | INSULATOR, xtal; 6 used               |

note: For optimum performance, diodes, transistors, and integrated circuits must be ordered by Motorola part numbers.

**LEGEND**  
 L = 132-150.8 MHz (HLD4051A)  
 H = 146-174 MHz (HLD4052A)

HLD4051A and HLD4052A Preampifier Boards PL-6036-E

| REFERENCE SYMBOL | MOTOROLA PART NO. | DESCRIPTION              |
|------------------|-------------------|--------------------------|
| C151, 152, 153   | 21-83596E10       | capacitor, fixed:        |
| C154H            | 21-83406D52       | 220 pF ± 20%; 500 V      |
| C154L            | 21-80067A01       | 2 pF ± 25 pF; 500 V      |
| C155             | 21-83596E10       | 1.5 pF ± 25 pF; 500 V    |
| C156H            | 21-83406D52       | 220 uF ± 20%; 500 V      |
| C156L            | 21-83406D52       | 2 pF ± 25 pF; 500 V      |
| P112             | 9-80180B01        | connector, receptacle:   |
|                  |                   | female; 6 contacts       |
| L151, 152        | 24-82549D48       | coil:                    |
| L153             | 24-80031A02       | choke; 2.2 uH            |
|                  |                   | 5-1/2 turns (coded gm)   |
| Q151             | 48-869839         | transistor: (see note)   |
|                  |                   | field-effect; type M9839 |
| R151             | 6-124A25          | resistor, fixed:         |
| R152             | 6-124A77          | 100 ± 5%; 1/4 W          |
|                  |                   | 15k                      |

**RECEIVER CIRCUIT BOARD DETAIL**

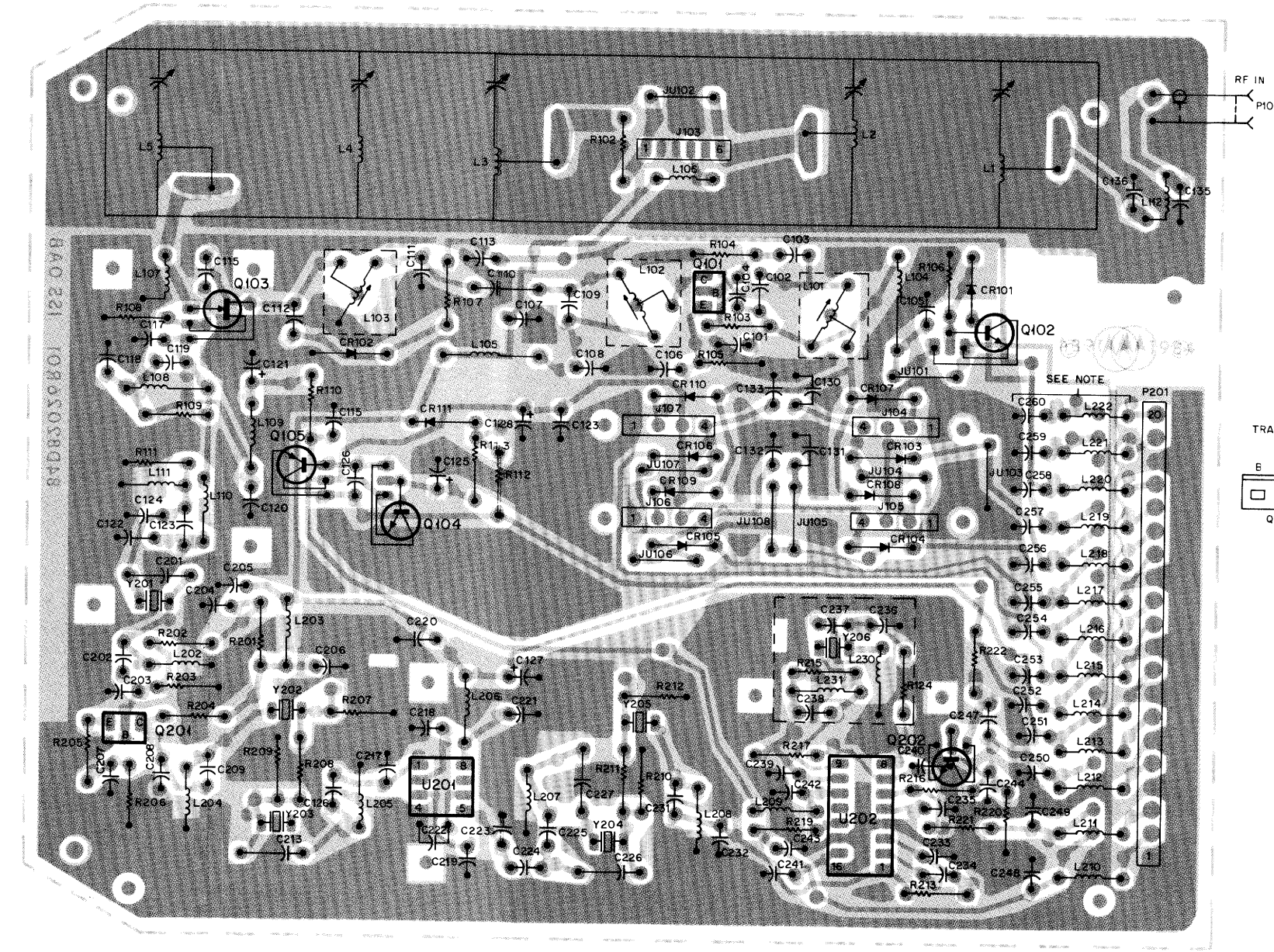

COMPONENT SIDE: BD-CEPS-41693-0  
 SOLDER SIDE: BD-CEPS-41694-0 SHOWN FROM COMPONENT SIDE  
 DL-CEPS-41695-0

**RF PREAMPLIFIER**

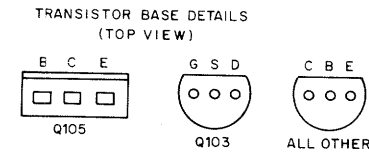
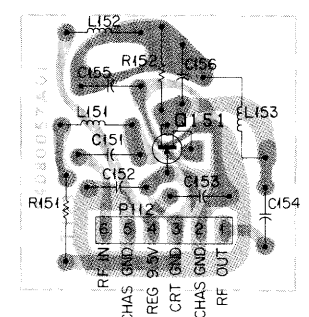

NOTE: C248 THRU C260 ARE DELETED AND Q101 THRU Q103 ARE REPLACED WITH JUMPERS FOR MODEL TRD6292A RECEIVER ONLY.

SHOWN FROM SOLDER SIDE

| MODEL    | FREQUENCY (MHZ) |
|----------|-----------------|
| TRD6291A | 132-150.8       |
| TRD6301A |                 |
| TRD6311A |                 |
| TRD6292A | 146-174         |
| TRD6302A |                 |
| TRD6312A |                 |

# VHF RECEIVER

MODEL SERIES TRD6290A, TRD6300A,  
AND TRD6310A

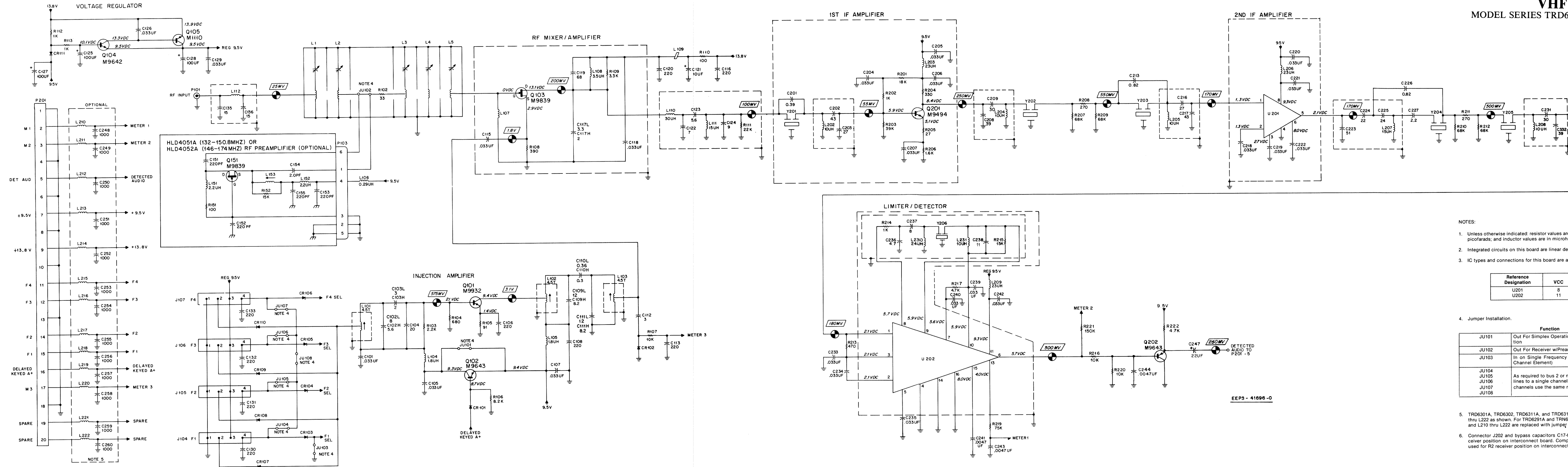
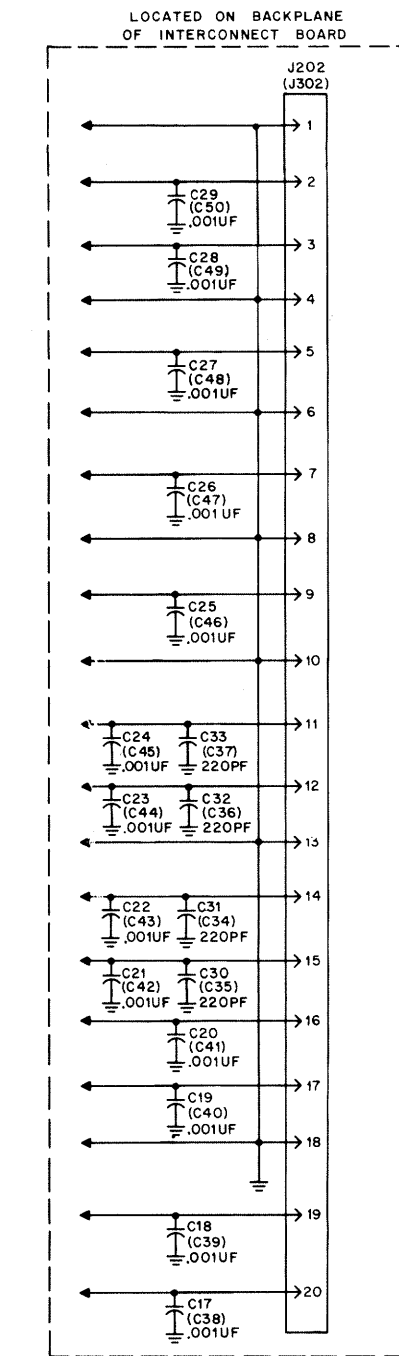

- NOTES:
- Unless otherwise indicated: resistor values are in ohms; capacitor values are in picofarads; and inductor values are in microhenries.
  - Integrated circuits on this board are linear devices.
  - IC types and connections for this board are as follows:

| Reference Designation | VCC | Gnd   |
|-----------------------|-----|-------|
| U201                  | 8   | 4     |
| U202                  | 11  | 4, 14 |

- Jumper Installation.
- | Jumper Designation | Function   |
|--------------------|--|
| JU101              | Out For Simplex Operation; In For RPTR Operation   |
| JU102              | Out For Receiver w/Preamp  |
| JU103              | In on Single Frequency Radios (To Enable F1 Channel Element)   |
| JU104              | As required to bus 2 or more channel select lines to a single channel element when these channels use the same receiver frequency. |
| JU105              |  |
| JU106              |  |
| JU107              |  |
| JU108              |  |

- TRD6301A, TRD6302, TRD6311A, and TRD6312A use C248 thru C260 and L210 thru L222 as shown. For TRD6291A and TRD6292A, C248 thru C260 are deleted and L210 thru L222 are replaced with jumper wires.
- Connector J202 and bypass capacitors C17-C29 and C30-C33 used for R1 receiver position on interconnect board. Component designators shown in ( ) used for R2 receiver position on interconnect board.

Schematic Diagram  
Motorola No. PEPS-41724-O  
(Sheet 2 of 2)  
5/1/85-UP

VHF RECEIVER



*Receiver Model Table*

| Model    | Frequency (MHz) | Description                                | Application  |
|----------|-----------------|--|--|
| TRD6171A | 132-150.8       | Multi-Frequency 10.7 MHz I-F, Non-Filtered | Used with Single Receiver Stations.                          |
| TRD6172A | 146-174         |  |  |
| TRD6181A | 132-150.8       | Multi-Frequency 10.7 MHz I-F, Filtered     | Used with 2-Receiver Stations and Repeater Stations.         |
| TRD6182A | 146-174         |  |  |
| TRD6191A | 132-150.8       | Multi-Frequency 10.8 MHz I-F, Filtered     | Used with 2 Receiver Stations where shifted I-F is required. |
| TRD6192A | 146-174         |  |  |

**SPECIFICATIONS**

|   |  |                                    |                                    |
|---|--|------------------------------------|------------------------------------|
| Input Impedance                             | 50 ohms  |                                    |                                    |
| Number of Channels                          | 1, 2, 3, or 4  |                                    |                                    |
| Frequency Separation                        | 2.0 MHz  |                                    |                                    |
| I-F Frequency                               | 10.7 MHz or 10.8 MHz   |                                    |                                    |
| EIA Modulation Acceptance                   | ± 7 kHz Minimum  |                                    |                                    |
| Frequency Stability                         | ± .0005% from -30°C to +60°C ambient (+25°C reference)<br>± .0002% Optional* |                                    |                                    |
| Channel Spacing                             | 20 kHz, 25/30 kHz  |                                    |                                    |
| Sensitivity:<br>20 dB Quieting<br>EIA SINAD | Less Than<br>Less Than   | With Preamp**<br>.25 uV<br>.20 uV  | Without Preamp<br>.50 uV<br>.35 uV |
| Selectivity:<br>EIA SINAD                   | 20 kHz Channel<br>25/30 kHz Channel  | 85 dB<br>95 dB                     | 90 dB<br>100 dB                    |
| Intermodulation:<br>EIA SINAD               | 20 kHz Channel<br>25/30 kHz Channel  | 75 dB (Minimum)<br>80 dB (Minimum) | 80 dB (Minimum)<br>85 dB (Minimum) |
| Spurious and Image Rejection                |  | 100 dB (Minimum)                   | 100 dB (Minimum)                   |

\* Available with option C621, C622, C623, C624.

\*\* Optional Model HLD4050A RF Preamp.

**1. DESCRIPTION**

**1.1** These receivers are fully transistorized units that receive FM signals on one to four crystal-controlled frequencies. In a multi-frequency receiver, only one frequency can be received at a time.

**1.2** Each receiver includes an rf preselector, mixer, local oscillator injection circuitry, high gain selective i-f

stages, quadrature detector, audio preamplifier, and a low-ripple 9.5 volt regulator. The receiver develops a low noise audio signal from a frequency modulated "on-channel" rf carrier in the 132-174 MHz range. An optional rf preamplifier may be used with any of these receivers.

**1.3** All circuits are constructed on a single plug-in circuit board which is easily accessible for servicing. The

**technical writing services**

receiver plugs into the backplane interconnect board which provides all dc, audio, and rf connections thereby eliminating all interconnecting wiring. All alignment points are accessible through the top of the rf compartment cover.

## 2. THEORY OF OPERATION

### 2.1 PI FILTER, RF PRESELECTOR, OPTIONAL PREAMPLIFIER

The receive port of the antenna switch is connected to the 5 cavity helical resonator rf preselector through the input "pi" filter. The "pi" filter, consisting of C135, C136, and L112, provides additional filtering for higher frequency spurious responses. The steep skirted rf preselector filter has a bandwidth of 2.0 MHz and ultimate rejection of 100 dB. To provide additional front-end selectivity while minimizing loss, the optional rf preamplifier is inserted in the housing between the second and third cavities. The output of the preselector (L5) is connected to the gate of N-channel JFET mixer, Q103.

### 2.2 LOCAL OSCILLATOR INJECTION CIRCUITRY

Plug in crystal oscillator modules (channel elements) provide a stable, temperature compensated frequency which is applied to injection amplifier Q101. Each receiver is capable of receiving up to four distinct frequencies. The output of Q101 (typical gain of 15 dB) passes through a two pole bandpass filter which attenuates unwanted harmonics of the injection frequency. The injection level of +12 dBm (typical) is coupled to the source of mixer Q103.

### 2.3 MIXER

Excellent intermodulation immunity is provided by a JFET mixer, Q103. The filtered receive input and injection signal are applied to the gate and source respectively. The output at the drain is applied to impedance matching circuitry which emphasizes the difference frequency applied to the i-f circuitry. Both the mixer and the following impedance matching circuitry are shielded.

### 2.4 I-F CIRCUITRY

**2.4.1** Several stages of filtering and amplification are employed in the i-f circuitry. Selective i-f filtering is accomplished using dual-resonator, mode coupled monolithic crystals cut to a fundamental frequency of 10.7 MHz or 10.8 MHz. Due to the inherent piezoelectric properties of the crystal material, input signals selectively produce mechanical vibrations which propagate through the device. At the output the same piezoelectric property selectively converts the mechanical vibrations into the i-f electrical signal.

**2.4.2** Refer to Figure 1. The high "Q" of the crystals create steep skirts which result in excellent on-channel intelligibility and off-channel signal rejection. The i-f circuitry requires no tuning and makes extensive use of shielding.

**2.4.3** The first crystal filter is a single 2-pole device, Y201. This stage is followed by a matching network, 16 dB discrete amplifier Q201, additional matching, and 4-pole filter Y202-Y203. The output of the first 4-pole filter is applied to a matching network and then to high gain (approximately 50 dB) 2nd i-f amplifier U201. The output of U201 is applied to matching circuitry, a 2nd 4-pole filter Y204-Y205, final matching circuitry, and limiter/detector U202.

### 2.5 LIMITER/DETECTOR

Limiter/Detector U202 is a 16-pin monolithic integrated circuit that internally includes three stages of i-f amplification for limiting, a quadrature fm detector, audio preamplifier, and alignment metering output. The recovered audio output of approximately 80 mV is applied to discrete audio preamplifier Q202-Q203, which provides the 250 mV receiver detected audio level required by the R1 (or R2) audio board in the control package. Adjustment of the quadrature detector is provided by L201.

### 2.6 9.5 VOLT REGULATOR

The regulated 9.5 volts and 13.8 volts provided to the receiver from the station power supply are applied to Q104 and Q105, resulting in a highly regulated and filtered 9.5 volts. This highly regulated 9.5 volts is supplied to the receiver channel elements, quadrature detector U202, and audio preamplifier Q202 to assure good receiver hum and noise performance.

### 2.7 DELAYED KEYED A +

This circuit (Q102) provides for disabling of the receiver channel element while the base station is in the transmit mode and prevents audio feed back to the receiver.

## 3. MAINTENANCE

Malfunctions in the receiver can be localized by using the optional built-in station metering kit or connecting a Motorola portable test set to the receiver metering receptacle and making stage measurements. The meter readings may be compared to the values shown on the receiver functional diagram, but preferably, a log of readings should be maintained for reference. Each new set of readings should then be compared to previous readings. An abrupt change in a meter reading indicates a circuit failure while a gradual change in a reading may indicate an impending failure which can be corrected before operation becomes marginal. Refer to the Receiver Maintenance section for further information.

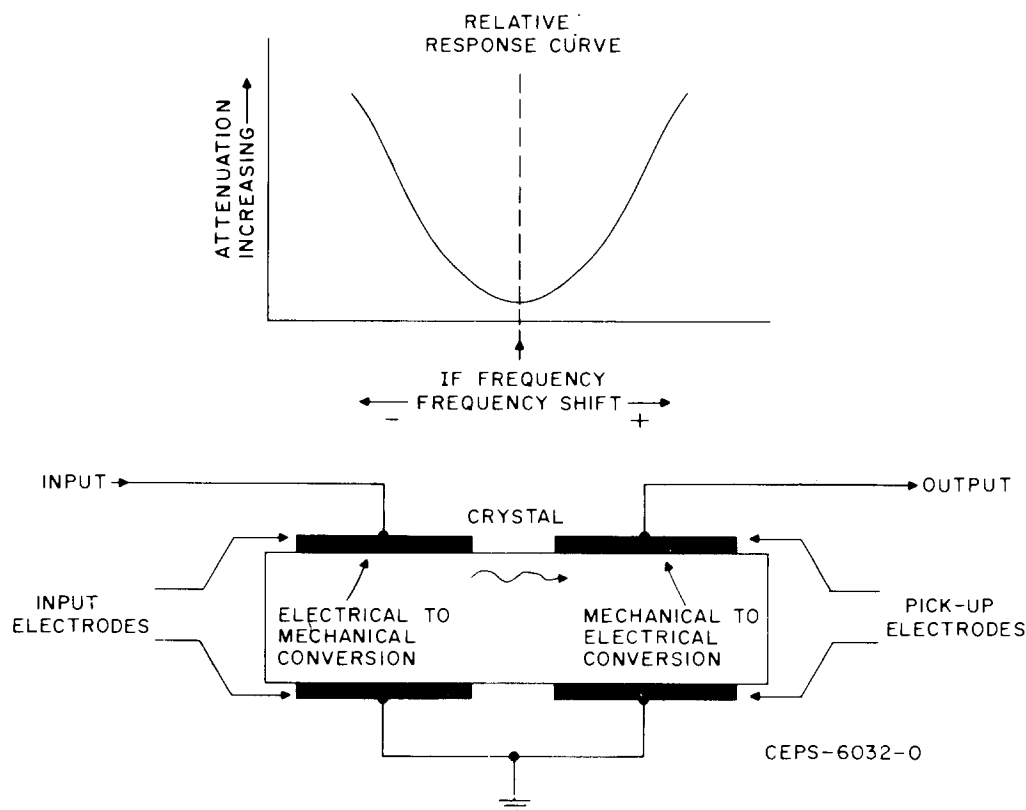

Figure 1. Simplified Piezoelectric Coupling Diagram

## 4. RECEIVER FUNCTIONAL TESTS

### 4.1 AUDIO AND SQUELCH TEST

The receiver and R1 audio board should provide 1.0 watts of audio when the VOLUME control on the R1 audio board is set fully clockwise and a strong carrier signal is received that is modulated  $\pm 3.0$  kHz deviation with a 1000 Hz tone. When the rf input signal is reduced to minimum and the SQUELCH control on the R1 audio board is set at threshold, the speaker should be quieted. Increasing the rf input signal a small amount should again produce noise in the speaker. On *Private-Line* models, no signal should be heard from the speaker unless the signal has the proper PL tone modulation. These circuits may be checked as follows:

Step 1. PL disable station. Connect speaker to test connector on mother board. Adjust the signal generator for 1000  $\mu$ V input to the receiver modulated with 1000 Hz tone for  $\pm 3.0$  kHz deviation.

Step 2. Connect an ac voltmeter to measure the voltage between pins 1 and 2 of the control metering socket.

Step 3. Set the VOLUME control on the R1 audio board fully clockwise. The ac voltmeter should indicate at least 2.8 volts rms.

Step 4. Decrease the signal generator output to minimum. Remove modulation from signal generator.

Step 5. Set the SQUELCH control at threshold, that is, clockwise until the noise just quiets.

Step 6. Increase the signal generator output slightly until the noise is again heard in the speaker. No more than .125  $\mu$ V should be required.

Step 7. On *Private-Line* radios, enable the PL function. No noise should be heard in the speaker.

Step 8. Modulate the rf signal with the proper *Private-Line* tone with  $\pm 500$  Hz deviation. Adjust signal generator output until noise is again heard in speaker. (See audio section for PL squelch specifications).



## 4.2 20 DB QUIETING TEST

With no signal input and the receiver unquieted, noise should be heard in the speaker or indicated on position 11 of the portable test set (function selector switch in RCVR position). When a carrier frequency signal is injected, the noise should decrease. No more than 0.5  $\mu$ V (.25  $\mu$ V if radio is equipped with rf preamplifier) should be required to decrease the noise 20 dB. This may be checked as follows:

Step 1. Unquiet receiver by turning the SQUELCH control on the R1 audio board fully counterclockwise. PL disable the receiver.

Step 2. Set the function selector switch on the portable test set to the RCVR position and the selector switch to position 11.

Step 3. Adjust VOLUME control on the R1 audio board for noise in the speaker and a reading on the test set meter. A reading of 1.5 V ac is a convenient reference value to use.

Step 4. Connect an rf signal generator (set to the receiver carrier frequency) to the antenna input connector.

Step 5. Beginning with minimum signal level, increase the signal generator output until the meter 11 reading drops to 1/10 the reference value in Step 3, that is 0.15 V ac. No more than 0.5 microvolt output from the signal generator should be required to quiet the receiver.

## 4.3 RECEIVER GAIN MEASUREMENTS

### NOTE

Before making any receiver gain measurements, make sure the case of every crystal filter has a good conductive path to ground. A continuity test should indicate less than 1 ohm between the crystal filter case and the receiver circuit board ground plating. A bad ground connection may cause errors in gain measurements.

Step 1. Proper receiver alignment is essential to this procedure portion of the Station Alignment. Perform a complete receiver alignment as given in the "Receiver Alignment" section of this manual.

Step 2. Refer to the Receiver Functional Block Diagram, receiver schematic diagram, and the receiver circuit board detail diagram while performing this procedure.

Step 3. Adjust the rf signal generator output frequency to the receive channel frequency. Adjust the rf signal generator output to provide the required receiver input voltage for a particular test point. Then, using an

rf ac voltmeter, measure the rf signal voltage between the test point and a nearby chassis ground point. At every test point, the measured voltage should be within  $\pm 6$  dB of the given value.

## 5. TROUBLESHOOTING TECHNIQUES

### 5.1 VISUAL INSPECTION

The first step in the troubleshooting procedure should be a thorough visual inspection of the receiver and, in particular, the receiver board. Corrosion, burned or damaged components are usually easily seen and may be the cause or a symptom of the receiver malfunction. An improperly installed receiver shield can cause a degradation in receiver performance.

After the "obvious" problems have been corrected, repeat the receiver board performance tests. If the tests still produce unsatisfactory results, refer to the receiver troubleshooting chart in this section. The troubleshooting chart provides a systematic procedure for isolation of the defective stage and component.

As much information as possible has been included on the troubleshooting chart. However, it will be necessary to occasionally refer to the receiver schematic diagram and circuit board detail. Detailed procedures regarding alignment as a troubleshooting technique, integrated circuit troubleshooting, receiver gain measurements, and crystal troubleshooting follow in the remaining paragraphs of this section.

### 5.2 ALIGNMENT AS A TROUBLESHOOTING TECHNIQUE

Low meter readings, and otherwise abnormal performance of the receiver are very often corrected by realignment. Therefore, alignment should be one of the first troubleshooting steps performed for these symptoms.

### 5.3 TROUBLESHOOTING INTEGRATED CIRCUITS

Integrated circuits (IC) are very reliable components and should not be replaced unless it is definitely indicated that the IC is the defective component. Before replacing an IC, make sure that the external components in the circuit are normal. The IC's on the receiver board may be checked by dc voltage measurements. Refer to schematic diagram for correct voltages.

### 5.4 TROUBLESHOOTING CRYSTALS

A defective filter crystal can best be found by performing an i-f gain check per the schematic diagram. A defective crystal will show an abnormally high insertion loss. If the crystal is found to be defective because of high insertion loss or an ungrounded case, it should be replaced.

### RECEIVER TROUBLESHOOTING CHART

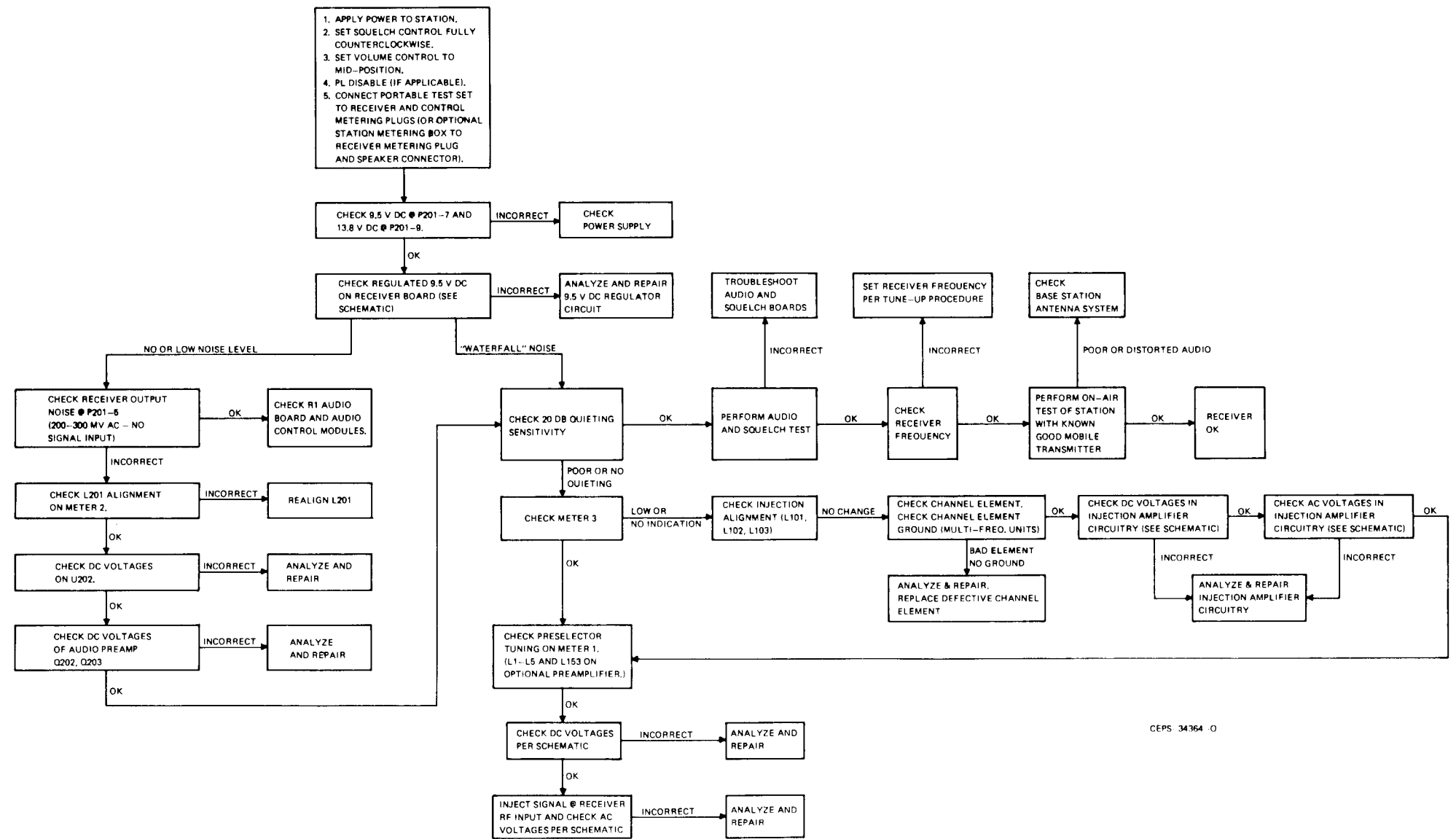

CEPS 34364 - 0

# RECEIVER ALIGNMENT

MODEL SERIES TRD6170A, TRD6180A, TRD6190A

## REQUIRED TEST EQUIPMENT FOR VHF RECEIVER SERVICING

| General Type           | Application   | Recommended Model  | Minimum Specifications   |
|------------------------|---|--|--|
| AC-DC VOM              | DC voltage measurements, general  | Motorola T1009   | Measurement range: 0-15 V dc<br>Sensitivity: 20,000 ohms/volt  |
| DC Multimeter          | DC voltage readings requiring a high input resistance meter                 | Motorola S1063   | Measurement range: 0-15 V dc<br>Input resistance: 11 megohms   |
| AC Voltmeter           | Audio voltage measurements  | Motorola S1053   | Measurement range: 0-10 V ac<br>Input resistance: 10 megohms   |
| RF Voltmeter           | RF voltage measurements   | Motorola S1339   | Measurement range: 100 uV-3 V from 1 MHz-512 MHz<br>Inputs: 50 ohm and high impedance  |
| Oscilloscope           | Waveform observation  | Motorola R1004   | Vertical sensitivity: 5 mV-10 V/division<br>Horizontal time base: 0.2 usec.<br>0.5 sec/division  |
| Frequency Meter        | Receiver frequency measurement  | Model R2400 Service Monitor with high stability oscillator (X suffix) option.<br>Frequency calibration recommended every 6 months or less. | Measurement range: 134-174 MHz<br>Frequency resolution: 10 Hz  |
| RF Signal Generator    | Receiver alignment and troubleshooting                                      | Motorola R2400 Service Monitor with attenuator   | Frequency range: 134-174 MHz<br>Output Level: 0.1 uV-100,000 uV<br>Must be capable of at least ± 3 kHz deviation when modulated by 1 kHz tone. |
| Audio Signal Generator | Audio circuit troubleshooting   | Motorola R1150   | Frequency range: 20 Hz-20 kHz<br>Output level: 50 mV-1 V   |
| PL Tone Generator*     | Tone-coded Private-Line decoder troubleshooting                             | Motorola R1150   | Frequency range: 10 Hz-9999 Hz<br>Output level: 0-3 V rms  |
| DPL Test Set**         | Digital Private-Line encoder-decoder troubleshooting                        | Motorola R2410A Service Monitor w/ DPL Encode  |  |
| Radio Test Set         | Meter readings at circuit metering points for alignment and troubleshooting | Motorola R1033 Portable Test Set with a RTK-4043A Meter Cable or a RTL-4130A Adapter with a TEK-40 (MICOR Adapter) Cable.                  |  |
| DC Power Supply        | DC power for shop service   | Motorola R1011   | 1-20 V dc<br>0-40A   |

\*Required for tone-coded Private-Line models only.  
\*\*Required for Digital Private-Line models only.

### NOTE

All test equipment, with the exception of the DPL test set and dc power supply, may be replaced by the Motorola R2001 System Analyzer. Tuning tools Motorola Part No. 66-82977K01 and 66-83398A01 are to be used for alignment purposes.

## RECEIVER FREQUENCY CALCULATIONS

Where

$f_o$  = channel element frequency  
 $f_c$  = carrier frequency  
 $f_{inj}$  = injection frequency

10.7 MHz I-F Receivers

$$f_{inj} = f_c - 10.7 \text{ MHz}$$

$$f_o = \frac{f_c - 10.7 \text{ MHz}}{3}$$

10.8 MHz I-F Receivers

$$f_{inj} = f_c - 10.8 \text{ MHz}$$

$$f_o = \frac{f_c - 10.8 \text{ MHz}}{3}$$

## VHF RECEIVER ALIGNMENT PROCEDURE

The tuning procedure should be performed using the Motorola S1056 portable Test Set. Connect metering cable to receiver metering socket on rear of interconnect board. Place the A/B switch in the A position and the FUNCTION SELECT switches to the RCVR position and meter reverse position. If using the TEK5-F or modified TEK5-B through TEK5-E meter panels, put the function switch to position C and the M1, 2 switch to the normal position. If using the optional station metering box, put the FORWARD-REVERSE switch in the FORWARD position.

### NOTE

For units containing two receivers, align each receiver individually using this same procedure.

| Step | Meter Position              | Adjust  | Procedure  |
|------|-----------------------------|---|--|
| 1    |                             | L1-L5   | Preset the rf preselector tuning screws per the coil preset chart.   |
| 2    |                             | L101, L102, L103                                | Preset the injection string coil slugs per the coil preset chart.  |
| 3    | 2                           | L201  | Starting with the slug flush with top of coil form, adjust the detector coil for the first reading of 24 uA on meter 2 (no input signal is necessary). After adjusting the detector coil, depress S201 (using a non-metallic alignment tool) while observing meter 2 reading. Release S201.  |
| 4    | 2                           | L201  | Quiet the radio by injecting a strong on-channel signal at the base station antenna connector or by setting a signal generator exactly on 10.7 MHz (or 10.8 MHz for receivers with shifted i-f frequency) and spraying into the i-f. Adjust the quadrature detector coil, L201, to obtain the same M2 reading as in Step 3.<br>Perform Step 5A for radios with maximum receive frequency separation of 0.5 MHz or less; perform Steps 5B and 5C for radios with maximum receive frequency separation greater than 0.5 MHz. |
| 5A   | 3                           | L103, L102, L101                                | Adjust the injection string coils for peak reading on meter 3 with lowest frequency selected. Repeat until no further improvement is obtained.   |
| 5B   | 3                           | L103, L102, L101                                | Adjust the injection string coils for peak reading on meter 3 with highest frequency selected. Repeat until no further improvement is obtained. Tune L103 for peak meter 3 reading with lowest frequency selected. Repeat L101 and L102 for peak on highest frequency and L103 on lowest frequency until no further improvement is obtained.   |
| 5C   | 3                           | L102  | If meter 3 reading on lowest frequency is less than meter 3 reading on highest frequency, increase meter 3 reading on lowest frequency by adjusting L102 for best balanced reading.  |
|      |                             | L103  | If meter 3 reading on highest frequency is less than meter 3 reading on lowest frequency, increase meter 3 reading on the highest frequency by adjusting L103 for best balanced reading. Make sure the frequency reading does not drop below the highest frequency reading.  |
| 6    | 1                           | L1-L5 (and L153 on optional preamp)             | Adjust L1, L2, (L153), L3, L4, L5 in order for peak reading on meter 1 using the highest frequency and maintaining meter 1 between 30 and 40 uA by adjusting the signal generator output. Repeat until no further improvement is obtained.<br>Perform Step 7 only for radios with maximum receive frequency separation greater than 0.5 MHz.   |
| 9    | 1                           | L1-L5 (and L153 on optional preamp)             | Adjust L1, L2, (L153), L3, L4, L5 once in that order for peak reading on meter 1 using the lowest frequency and maintaining meter 1 between 30 uA and 40 uA by adjusting the signal generator output.  |
| 8    | Audio zero beat (See Note)  | Channel Element                                 | For each frequency, set rf generator to the carrier frequency (± 75 Hz) without modulation. With a wire connected to a 1 mV, 10.7 MHz (or 10.8 MHz for receivers with shifted i-f frequency) signal source, "spray" the signal near Q201. Warp channel element for audio zero beat.<br>Perform Step 9A for radios with maximum receive frequency separation of 0.5 MHz or less; perform Step 9B for radios with maximum receive frequency separation greater than 0.5 MHz.   |
| 9A   | AC Voltmeter across speaker | L5 (or L1 and L2 on rcvr. with optional preamp) | Adjust L5 (or L1 and L2 in Preamp Radios) for best quieting with the highest frequency selected. Receiver tuning is now complete.  |
| 9B   | AC Voltmeter across speaker | L1-L5 (Do not adjust L153 on optional preamp)   | Check 20 dB quieting sensitivity on all frequencies. If necessary, retune L1 and L2 once on highest frequency for best quieting. Check sensitivities again and if necessary retune L3-5 once, on the lowest frequency, for best quieting. Receiver tuning is now complete.   |

Note: Alternate Method of Setting Receiver Oscillator Frequency Using a Frequency Counter.

"Sniff" the injection frequency in the following manner: Connect a coax cable which has 1 to 2 inches of ground shield removed from one end to the frequency counter. Insert this end into coil form L103 in the receiver injection circuit. This should provide enough signal to accurately gate the counter. For each frequency, adjust the receiver channel element for the injection frequency ± 75 Hz. (Calculate injection frequency using appropriate formula at beginning of alignment procedure.)

## RECEIVER METER READINGS

When the receiver is properly aligned, meter deflections should fall within the following limits. Where two numbers are given, the readings are non-preamp/preamp.

| Switch Position           | Meter 1                          | Meter 2                    | Meter 3            |
|---------------------------|----------------------------------|----------------------------|--------------------|
| Meter Reading (no signal) | 12/14 uA (min)<br>30/32 uA (max) | 20 uA (min)<br>28 uA (max) | 10 uA (min)        |
| Function Metered          | Limiters/Detector                | Detector Alignment         | Receiver Injection |

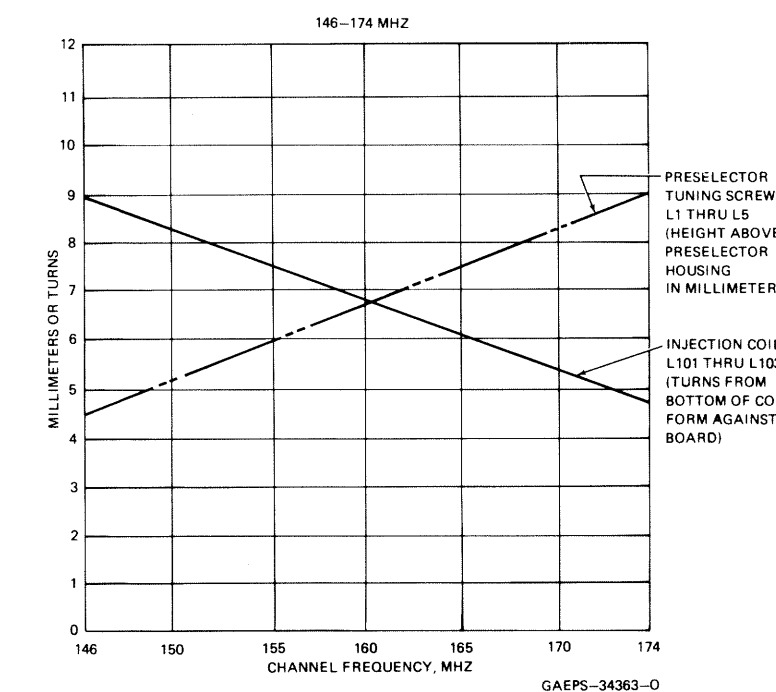
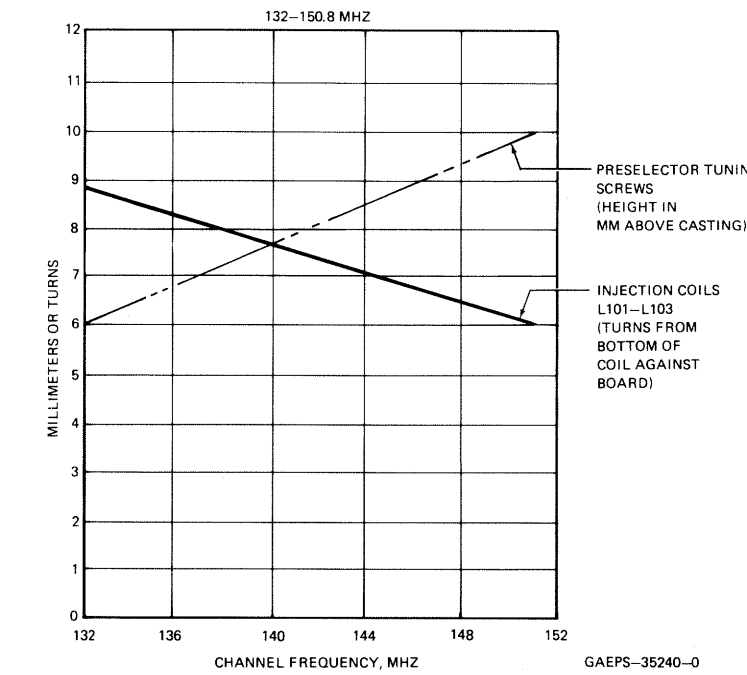

Coil Preset Charts

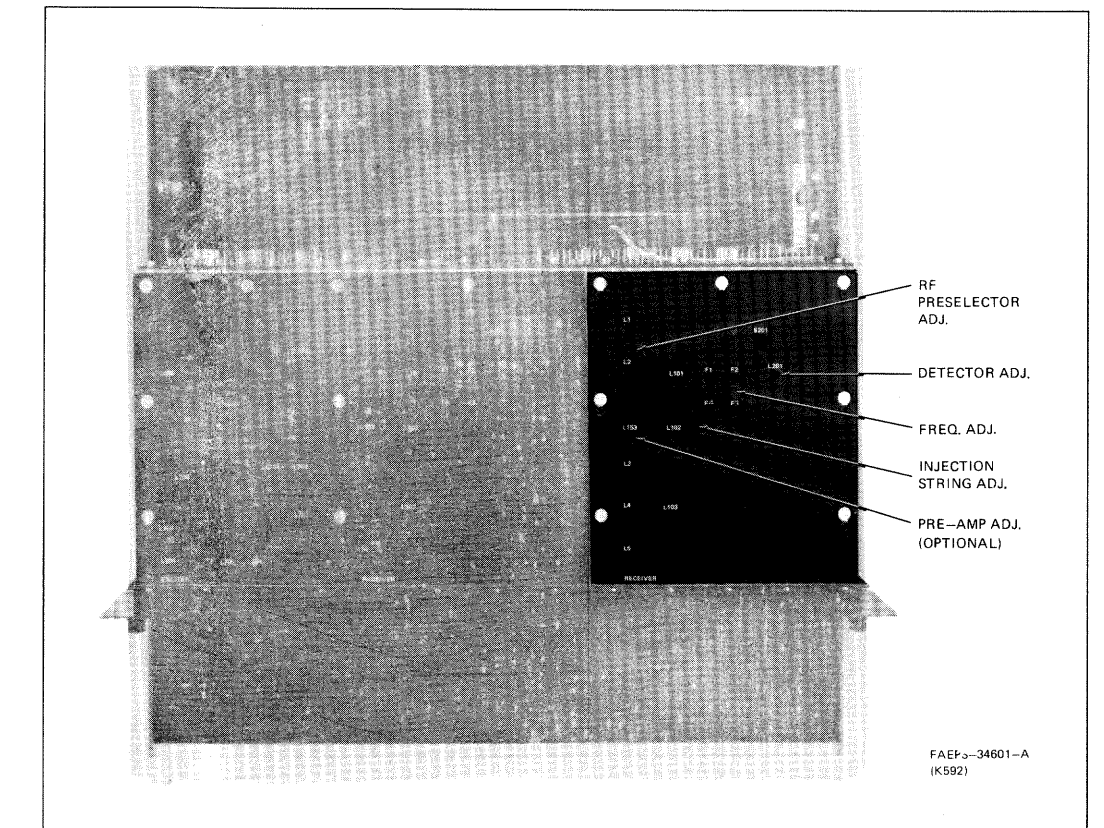
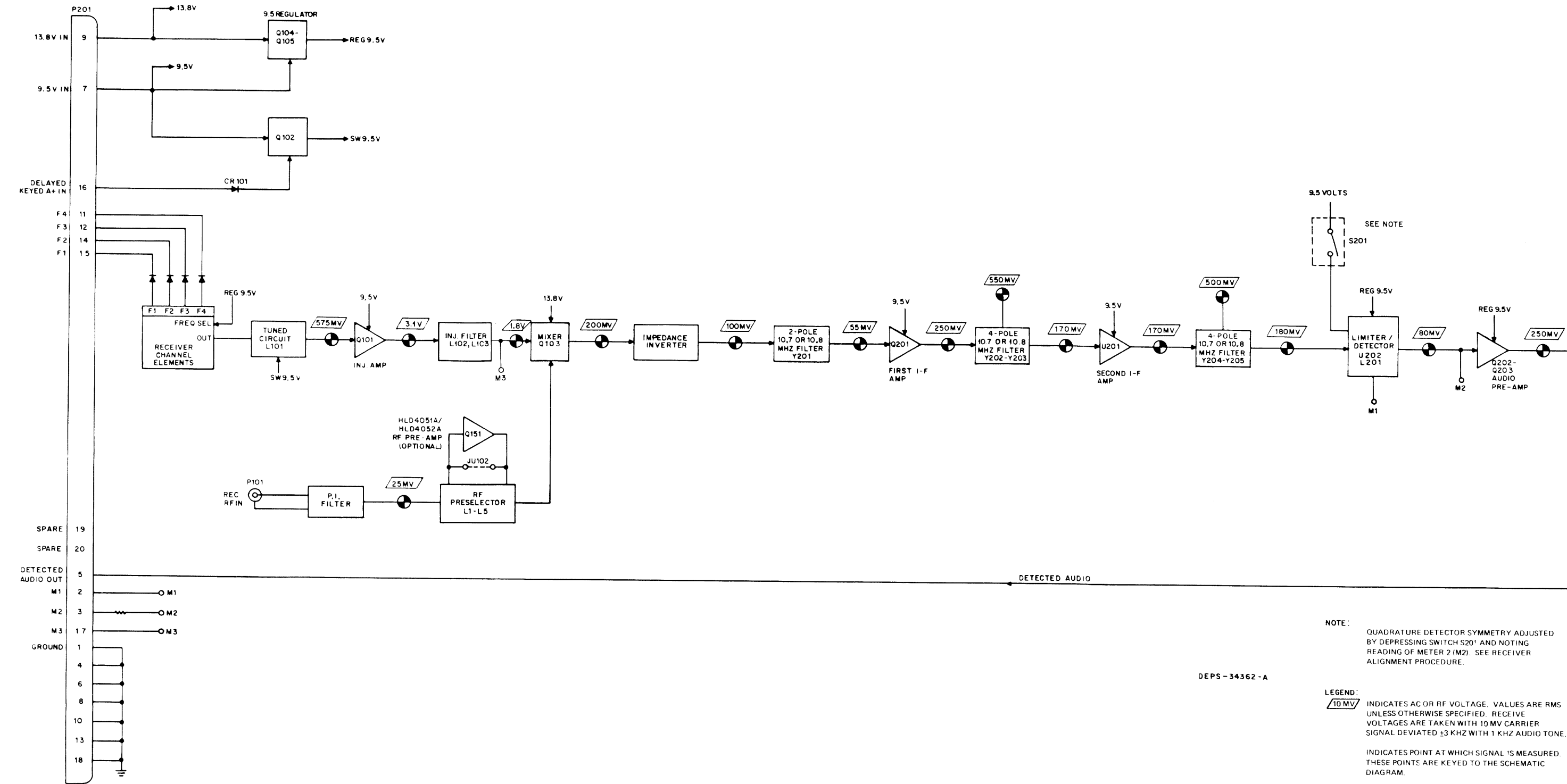

Figure 2. Receiver Alignment Adjustment Locations

# RECEIVER MAINTENANCE

## RECEIVER FUNCTIONAL BLOCK DIAGRAM



## RECEIVER CIRCUIT BOARD DETAIL

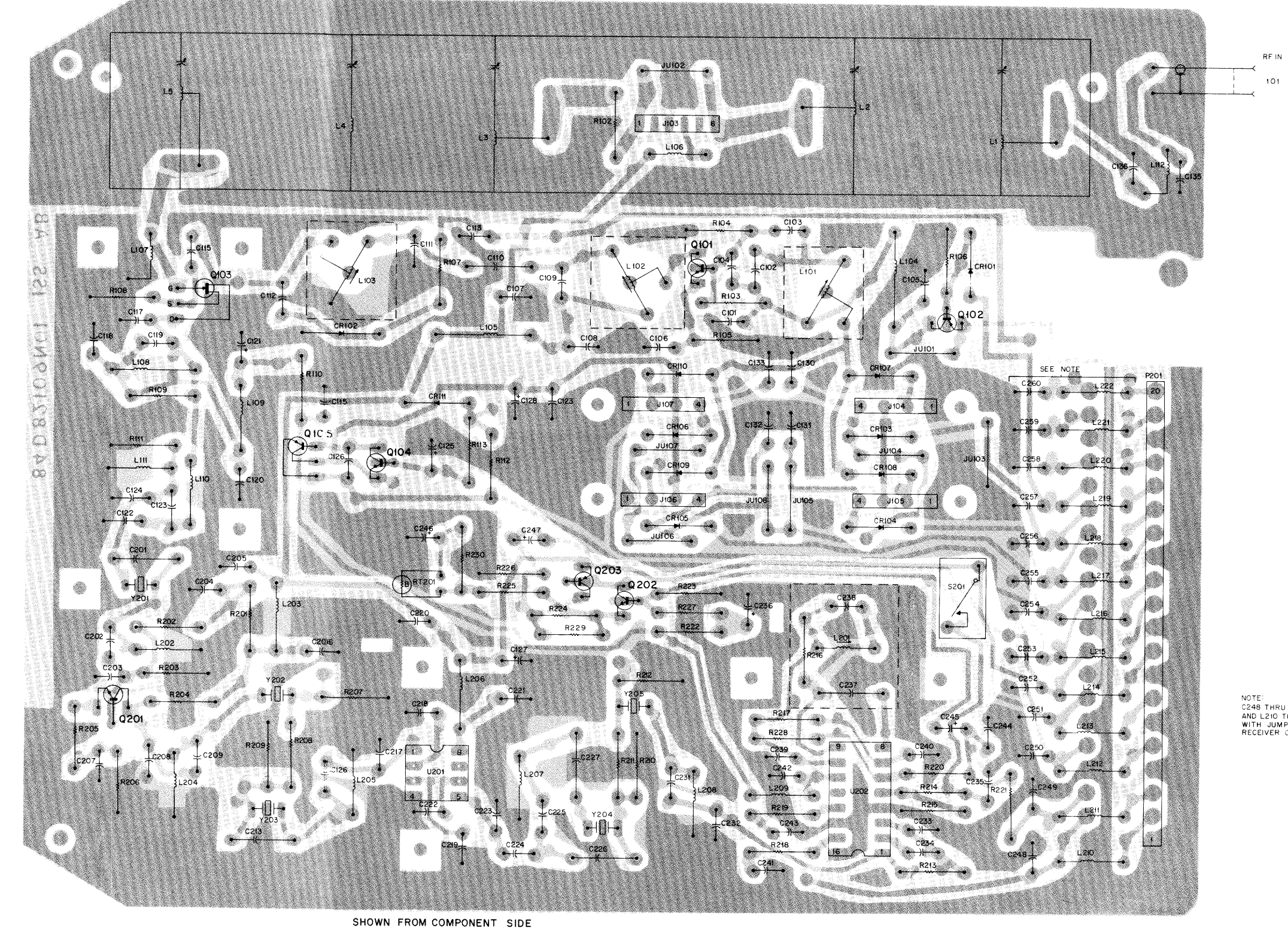

## RF PREAMPLIFIER

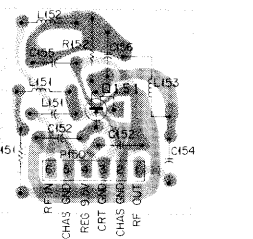

SHOWN FROM SOLDER SIDE

**LEGEND**  
 L = 136-144 MHz (HLD4051A)  
 H = 146-174 MHz (HLD4052A)

**NOTE:**  
 C248 THRU C260 ARE DELETED AND L210 THRU L222 ARE REPLACED WITH JUMPERS FOR MODEL TR6 6172A RECEIVER ONLY.

RECEIVER SCHEMATIC DIAGRAM

| MODEL    | FREQUENCY (MHZ) |
|----------|-----------------|
| TRD6171A |                 |
| TRD6181A | 132-150.8       |
| TRD6191A |                 |
| TRD6172A |                 |
| TRD6182A | 146-174         |
| TRD6192A |                 |

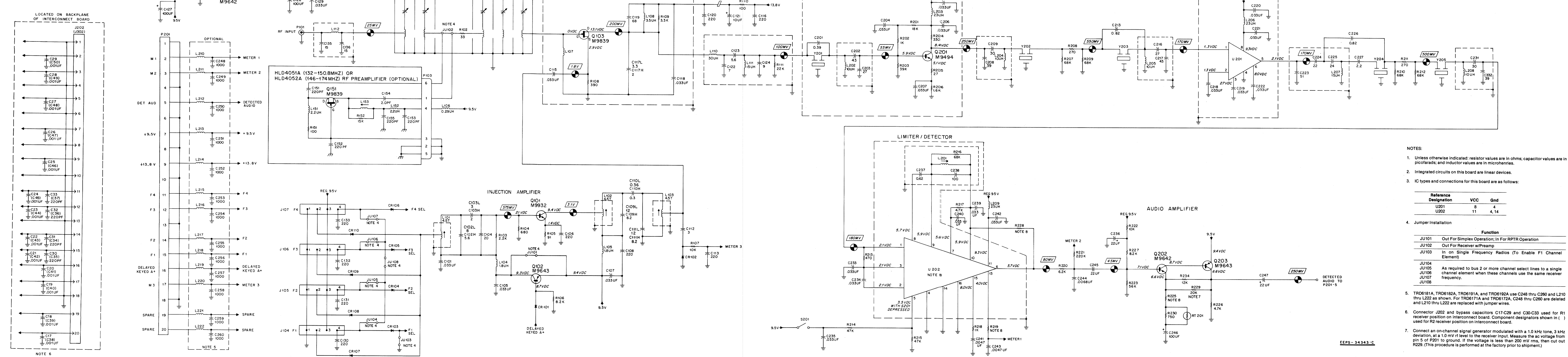

- NOTES:
- Unless otherwise indicated, resistor values are in ohms; capacitor values are in picofarads; and inductor values are in microhenries.
  - Integrated circuits on this board are linear devices.
  - IC types and connections for this board are as follows:

| Reference Designation | VCC | Gnd   |
|-----------------------|-----|-------|
| U201                  | 8   | 4     |
| U202                  | 11  | 4, 14 |

4. Jumper Installation
- | Jumper | Function   |
|--------|--|
| JU101  | Out For Simplex Operation; In For RPTR Operation   |
| JU102  | Out For Receiver w/Preamp  |
| JU103  | In on Single Frequency Radios (To Enable F1 Channel Element)   |
| JU104  | As required to bus 2 or more channel select lines to a single channel element when these channels use the same receiver frequency. |

- TRD6181A, TRD6182A, TRD6191A, and TRD6192A use C248 thru C260 and L210 thru L222 as shown. For TRD6171A and TRD6172A, C248 thru C260 are deleted and L210 thru L222 are replaced with jumper wires.
- Connector J202 and bypass capacitors C17-C29 and C30-C33 used for R1 receiver position on interconnect board. Component designators shown in ( ) used for R2 receiver position on interconnect board.
- Connect an on-channel signal generator modulated with a 1.0 kHz tone, 3 kHz deviation, at a 1.0 mV r/l level to the receiver input. Measure the ac voltage from pin 5 of P201 to ground. If the voltage is less than 200 mV rms, then cut out R229. (This procedure is performed at the factory prior to shipment.)

EEPS-34343-C

PARTS LISTS SHOWN ON BACK OF THIS DIAGRAM

Motorola No. PEPS-34544-D  
(Sheet 2 of 2)  
9/30/85-UP

# parts list

TRD6171A, TRD6172A 10.7 MHz I-F, Receiver, Non-Filtered  
 TRD6181A, TRD6182A 10.7 MHz I-F, Receiver, Filtered  
 TRD6191A, TRD6192A 10.8 MHz I-F, Receiver, Filtered

PL-7936-D

| REFERENCE SYMBOL | MOTOROLA PART NO. | DESCRIPTION  |
|------------------|-------------------|--|
|                  |                   | <b>capacitor, fixed: pF ± 5%; 50 V:</b><br>unless otherwise stated |
| C101             | 21-11021H06       | .033 uF + 80-20%   |
| C102L            | 21-82204B31       | 8.0 ± 0.25 pF  |
| C102H            | 21-82204B75       | 5.6 ± 0.25 pF  |
| C103L            | 21-11022G12       | 3 ± 0.25 pF  |
| C103H            | 21-11022G08       | 2 ± 0.25 pF  |
| C104             | 21-11022G37       | 20   |
| C105             | 21-11021H06       | .033 uF + 80-20%   |
| C106             | 21-11021E05       | 220 ± 10%  |
| C107             | 21-11021H06       | .033 uF + 80-20%   |
| C108             | 21-11021E05       | 220 ± 10%  |
| C109L            | 21-11022H29       | 12   |
| C109H            | 21-11022H23       | 8.1 ± 0.5 pF; N150   |
| C110L            | 21-842041         | 0.36   |
| C110H            | 21-82450B04       | 0.3 ± 10%; 500 V   |
| C111L            | 21-11022H29       | 12   |
| C111H            | 21-11022H23       | 8.2 ± 0.5 pF; N150   |
| C112             | 21-11022G12       | 3 ± 0.25 pF  |
| C113             | 21-11021E05       | 220 ± 10%  |
| C115             | 21-11021H06       | .033 uF + 80-20%   |
| C116             | 21-11021E05       | 220 ± 10%  |
| C117L            | 21-11014H13       | 3.3 ± 0.25 pF  |
| C117H            | 21-11022G08       | 2 ± 0.25 pF  |
| C118             | 21-11021H06       | .033 uF + 80-20%   |
| C119             | 21-11022G50       | 68   |
| C120             | 21-11021E05       | 220 pF ± 10%   |
| C121             | 23-11019A21       | 10 uF ± 20%; 35 V  |
| C122             | 21-82989E17       | 7 ± 0.25 pF; 500 V   |
| C123             | 21-83406D64       | 5.6 ± 0.25 pF  |
| C124             | 21-82989E21       | 9 ± 0.25 pF; 500 V   |
| C125             | 23-11019A46       | 100 uF ± 20%; 25 V   |
| C126             | 21-11021H06       | .033 uF + 80-20%   |
| C127, 128        | 23-11019A46       | 100 uF ± 20%; 25 V   |
| C129             | 21-11021H06       | .033 uF + 80-20%   |
| C130 thru 133    | 21-11021E05       | 220 ± 10%  |
| C135, 136        | 21-11022G34       | 15   |
| C201             | 21-82450B07       | 0.39; 500 V  |
| C202             | 21-11022G45       | 43   |
| C203             | 21-11022G40       | 27   |
| C204 thru 207    | 21-11021H06       | .033 uF + 80-20%   |
| C208             | 21-11022G44       | 39   |
| C209             | 21-11022G41       | 30   |
| C213             | 21-82450B44       | 0.82; 500 V  |
| C216             | 21-11022G40       | 27   |
| C217             | 21-11022G45       | 43   |
| C218 thru 222    | 21-11021H06       | .033 uF + 80-20%   |
| C223             | 21-11014H42       | 51; 100 V  |
| C224             | 21-11022G38       | 22   |
| C225             | 21-11022G39       | 24   |
| C226             | 21-82450B44       | 0.82; 500 V  |
| C227             | 21-82450B17       | 2.2; 500 V   |
| C231             | 21-11022G41       | 30   |
| C232             | 21-11022G44       | 39   |
| C233 thru 235    | 21-11021H06       | .033 uF + 80-20%   |
| C236             | 23-11019A27       | 22 uF ± 20%; 25 V  |
| C237             | 21-82450B46       | 0.62 ± 5%; 500 V   |
| C238             | 21-82358G12       | 100; 100 V; N080   |
| C239, 240        | 21-11021H06       | .033 uF + 80-20%   |
| C241             | 21-11021E21       | .0047 uF ± 10%   |
| C242             | 21-11021H06       | .033 uF + 80-20%   |
| C243             | 21-11021E21       | .0047 uF ± 10%   |
| C244             | 21-11017B07       | .0068 uF ± 10%   |
| C245             | 23-11019A27       | 22 uF ± 20%; 25 V  |
| C246             | 23-11019A46       | 100 uF ± 20%; 25 V   |
| C247             | 23-11019A27       | 22 uF ± 20%; 25 V  |
| C248 thru 260    | 21-11021E13       | 1000 (TRD6182A, 6192A)   |
|                  |                   | <b>diode: (see note)</b>   |
| CR101            | 48-83654H01       | silicon  |
| CR102            | 48-82139G01       | germanium  |
| CR103 thru 110   | 48-83654H01       | silicon  |
| CR111            | 48-83654H02       | silicon  |
|                  |                   | <b>connector, plug:</b>  |
| J103             | 28-80181B01       | male; 6-contact  |
| J104 thru 107    | 28-80096A01       | male; 4-contact  |
|                  |                   | <b>coil, rf:</b>   |
| L1L              | 24-80032A07       | helical; VIO   |
| L1H              | 24-80032A02       | helical; RED   |
| L2L              | 24-80032A08       | helical; BRN   |
| L2H              | 24-80032A03       | helical; ORG   |
| L3L              | 24-80032A09       | helical; GRN   |
| L3H              | 24-80032A05       | helical; NAT   |
| L4L              | 24-80032A06       | helical; BLU   |
| L4H              | 24-80032A01       | helical; NAT   |
| L5L              | 24-80032A10       | helical; BLU   |
| L5H              | 24-80032A04       | helical; YEL   |
| L101, 102        | 24-80065A01       | 4-1/2 turns; coded RED   |
| L103             | 24-80065A03       | 4-1/2 turns; coded YEL   |
| L104, 105        | 24-82549D29       | choke; 1.8 uH  |
| L106             | 24-82723H04       | choke; 0.29 uH   |
| L107             | 24-83884G12       | 117 nH (8-1/2 turns); coded RED                                    |
| L108             | 24-82835G11       | choke; 3.5 uH  |
| L109             | 24-83961B02       | 5 turns; coded GRN   |

| REFERENCE SYMBOL | MOTOROLA PART NO. | DESCRIPTION   |
|------------------|-------------------|---|
| L110             | 24-83397L11       | choke; 30 uH  |
| L111             | 24-83397L08       | choke; 15 uH  |
| L112             | 24-83884G08       | 73 nH; 5-1/2 turns; coded ORG                                   |
| L201             | 24-84419D04       | 23-1/2 turns  |
| L202             | 24-83397L07       | choke; 10 uH  |
| L203             | 24-82723H03       | choke; 23 uH  |
| L204, 205        | 24-83397L07       | choke; 10 uH  |
| L206             | 24-82723H03       | choke; 23 uH  |
| L207             | 24-83397L08       | choke; 15 uH  |
| L208             | 24-83397L07       | choke; 10 uH  |
| L209             | 24-82723H03       | choke; 23 uH  |
| L210 thru 222    | 24-83961B01       | choke; 3 turns (BRN) (TRN6181A, TRD6182A, TRN6191A, TRD6192A)   |
|                  | or 6-11009B23     | resistor jumper (TRN6171A, TRD6172A only)                       |
|                  |                   | <b>connector, receptacle:</b>                                   |
| P101             | 9-82872N01        | female  |
| P200, P201       | 9-83497F05        | female; 10-contact (2 ea.)                                      |
|                  |                   | <b>transistor: (see note)</b>                                   |
| Q101             | 48-869932         | NPN; type M9932   |
| Q102             | 48-869643         | PNP; type M9643   |
| Q103             | 48-869839         | field-effect; type M9839  |
| Q104             | 48-869642         | NPN; type M9642   |
| Q105             | 48-84411L10       | PNP; type M1110   |
| Q201             | 48-869494         | NPN; type M9494   |
| Q202             | 48-869642         | NPN; type M9642   |
| Q203             | 48-869643         | PNP; type M9643   |
|                  |                   | <b>resistor, fixed: ± 5%; 1/4 W:</b><br>unless otherwise stated |
| R102             | 6-11009A13        | 33  |
| R103             | 6-11009A57        | 2.2k  |
| R104             | 6-11009A45        | 680   |
| R105             | 6-11009A24        | 91  |
| R106             | 6-11009A71        | 8.2k  |
| R107             | 6-11009A73        | 10k   |
| R108             | 6-11009A39        | 390   |
| R109             | 6-11009A61        | 3.3k  |
| R110             | 6-11009A25        | 100   |
| R111             | 6-11009A81        | 22k   |
| R112, 113        | 6-11009A49        | 1k  |
| R201             | 6-11009A79        | 18k   |
| R202             | 6-11009A49        | 1k  |
| R203             | 6-11009A87        | 39k   |
| R204             | 6-11009A37        | 330   |
| R205             | 6-11009A11        | 27  |
| R206             | 6-11009A54        | 1.6k  |
| R207             | 6-11009A93        | 68k   |
| R208             | 6-11009A35        | 270   |
| R209, 210        | 6-11009A83        | 68k   |
| R211             | 6-11009A35        | 270   |
| R212             | 6-11009A93        | 68k   |
| R213             | 6-11009A41        | 470   |
| R214, 215        | 6-11009A89        | 47k   |
| R216             | 6-11009A93        | 68k   |
| R217             | 6-11009A65        | 4.7k  |
| R218             | 6-11009A49        | 1k  |
| R219             | 6-11009A91        | 56k   |
|                  | or                |   |
|                  | 6-11009A94        | 75k (see note 8 on schematic)                                   |
| R220             | 6-11009A68        | 6.2k  |
| R221             | 6-11009B06        | 220k  |
| R222             | 6-11009A73        | 10k   |
| R223             | 6-11009A91        | 56k   |
| R224             | 6-11009A76        | 12k   |
| R225             | 6-11009A53        | 1.5k  |
|                  | or                |   |
|                  | 6-11009A51        | 1.2k (see note 8 on schematic)                                  |
| R226             | 1009A65           | 4.7k  |
| R227             | 6-11009A71        | 8.2k  |
| R228             | 6-11009A66        | 5.1k  |
| R229             | 6-11009A80        | 20k   |
| R230             | 6-11009A46        | 750   |
|                  |                   | <b>thermistor:</b>  |
| RT201            | 6-83600K02        | 1k @ 25°C   |
|                  |                   | <b>switch:</b>  |
| S201             | 40-82765M01       | spst  |
|                  |                   | <b>integrated circuit: (see note)</b>                           |
| U201             | 51-83629M05       | second i-f amplifier  |
| U202             | 51-83629M60       | quad detector   |
|                  | or                |   |
|                  | 51-84561L84       | (see note 8 on schematic)                                       |
|                  |                   | <b>crystal: (see note)</b>                                      |
| Y201             | 91-80011E04       | 10.7 MHz (TRD6172A, TRD6182A, TRN6171A, TRD6181A)               |
|                  | or 48-84396K07    | 10.8 MHz (TRD6192A, TRD6191A)                                   |
| Y202 thru 205    | 91-80011E05       | 10.7 MHz (TRD6172A, TRD6182A, TRD6171A, TRD6181A)               |
|                  | or 48-84396K06    | 10.8 MHz (TRD6192A, TRD6191A)                                   |
|                  |                   | <b>mechanical parts</b>   |
|                  | 2-80045A01        | NUT, retainer: M5 x 0.8; 5 used                                 |

| REFERENCE SYMBOL | MOTOROLA PART NO. | DESCRIPTION                           |
|------------------|-------------------|---------------------------------------|
|                  | 3-3375            | SCREW, tapping: 6-20 x 5/16"; 14 used |
|                  | 3-80012A04        | SCREW, set; 5 used                    |
|                  | 3-84256M01        | SCREW, tapping; 8 used                |
|                  | 5-10277A17        | GROMMET, plastic                      |
|                  | 5-84220B01        | GROMMET, panel; 8 used                |
|                  | 15-80008A01       | HOUSING                               |
|                  | 26-80062C01       | SHIELD, IC                            |
|                  | 26-80121A01       | SHIELD, can; 5 used                   |
|                  | 26-80144B03       | SHIELD, mixer                         |
|                  | 26-80196A01       | SHIELD, coil; 3 used                  |
|                  | 26-82868N01       | SHIELD, 1st i-f                       |
|                  | 26-82870N01       | SHIELD, input                         |
|                  | 26-84173N01       | SHIELD, mag.                          |
|                  | 26-82871N01       | SHIELD, quad                          |
|                  | 26-83264P01       | SHIELD, coil; L201                    |
|                  | 26-84173N01       | SHIELD, magnetic; L201                |
|                  | 26-83347N01       | SHIELD, 2nd i-f                       |
|                  | 26-83596M01       | SHIELD, antenna                       |
|                  | 26-84243B03       | SHIELD, mixer                         |
|                  | 45-83824N01       | CARD, ejector; 2 used                 |
|                  | 75-05295B01       | INSULATOR, xtal; 5 used               |

**note:** For optimum performance, diodes, transistors, and integrated circuits must be ordered by Motorola part numbers.

**LEGEND**  
 L = 132-150.8 MHz (HLD4051A)  
 H = 146-174 MHz (HLD4052A)

HLD4051A and HLD4052A Preampifier Boards PL-6036-E

| REFERENCE SYMBOL | MOTOROLA PART NO. | DESCRIPTION                   |
|------------------|-------------------|-------------------------------|
|                  |                   | <b>capacitor, fixed:</b>      |
| C151, 152, 153   | 21-83596E10       | 220 pF ± 20%; 500 V           |
| C154H            | 21-83406D52       | 2 pF ± .25 pF; 500 V          |
| C154L            | 21-80067A01       | 1.5 pF ± .25 pF; 500 V        |
| C155             | 21-83596E10       | 220 uF ± 20%; 500 V           |
| C156H            |                   | not used                      |
| C156L            | 21-83406D52       | 2 pF ± .25 pF; 500 V          |
|                  |                   | <b>connector, receptacle:</b> |
| P112             | 9-80180B01        | female; 6 contacts            |
|                  |                   | <b>coil:</b>                  |
| L151, 152        | 24-82549D48       | choke; 2.2 uH                 |
| L153             | 24-80031A02       | 5-1/2 turns (coded grn)       |
|                  |                   | <b>transistor: (see note)</b> |
| Q151             | 48-869839         | field-effect; type M9839      |
|                  |                   | <b>resistor, fixed:</b>       |
| R151             | 6-124A25          | 100 ± 5%; 1/4 W               |
| R152             | 6-124A77          | 15k                           |

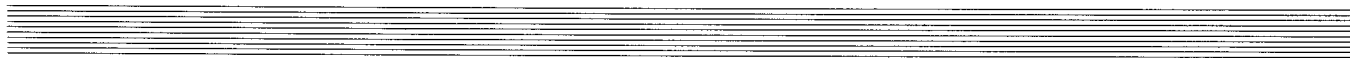

*Model Chart for Intermittent Duty Transmitter*

| Item       | Description                                   |
|------------|---|
| TLD2532A   | 110 W Power Amplifier                         |
| TKN8313A   | Internal Cable Kit                            |
| TFD6452A   | Harmonic Filter                               |
| TLD9252A   | Power Amplifier Board                         |
| TLD9272A   | Power Control Board                           |
| TRN5141A   | PA Hardware                                   |
| TRN5378A   | Closing Hardware                              |
| TLD9232A/B | Simplex Exciter Board (Simplex Stations Only) |
| TLD9242A/B | Duplex Exciter Board (Duplex Stations Only)   |

*Model Chart for Continuous Duty Transmitter*

| Item       | Frequency Coverage Chart      |               |
|------------|-------------------------------|---------------|
|            | Description                   | Frequency     |
| TLD2601A   | 100 Watt Power Amplifier Deck | 132-150.8 MHz |
| TLD2602A   | 100 Watt Power Amplifier Deck | 150.8-162 MHz |
| TLD2603A   | 100 Watt Power Amplifier Deck | 162-174 MHz   |
| TLD9231A   | Simple Exciter Board          | 132-150.8 MHz |
| TLD9232A/B | Simplex Exciter Board         | 146-174 MHz   |
| TLD9241A   | Duplex Exciter Board          | 132-150.8 MHz |
| TLD9242A/B | Duplex Exciter Board          | 146-174 MHz   |

*Assembly Breakdown Chart*

| TLD2601A | TLD2602A | TLD2603A | Item   | Description  |
|----------|----------|----------|--|--|
| X        |          |          | TFD6101A                                     | Harmonic Filter, 132-150.8 MHz   |
|          | X        | X        | TFD6102A                                     | Harmonic Filter, 150.8-174 MHz   |
| X        |          |          | TLD5952A                                     | Power Amplifier Board, 132-150.8 MHz   |
|          | X        |          | TLD5953A                                     | Power Amplifier Board, 150.8-162 MHz   |
|          |          | X        | TLD5954A                                     | Power Amplifier Board, 162-174 MHz   |
| X        | X        | X        | TLD5960A                                     | Power Control Board  |
| X        | X        | X        | TLN2424A<br>includes<br>includes<br>includes | Power Amplifier Input Bracket Assembly<br>TRN5566A PA Input Bracket<br>TRN5585A Exciter Control Voltage Regulator<br>TKN8336A PA Cable Kit |
| X        | X        | X        | TRN5577A                                     | PA Casting & Hardware  |
| X        | X        | X        | TRN5586A                                     | PA Hardware  |
| X        | X        | X        | TRN8069A                                     | Suppression Network  |

**PERFORMANCE SPECIFICATIONS**

|                                 |   |
|---------------------------------|---|
| Frequency Separation            | 3 MHz   |
| Number of Channels              | 1, 2, 3, or 4   |
| Frequency Stability             | ± .0005% from -30°C to +60°C<br>(25°C reference)<br>± .0002% optional*  |
| Power Output                    | Intermittent duty transmitter: 60 to 110 watts continuously variable, into 50 ohm load (EIA intermittent duty cycle)<br>Continuous duty transmitter: 50 to 100 watts, continuously variable, into 50 ohm load (EIA continuous duty cycle) |
| Maximum Frequency Deviation     | ± 5 kHz @1 kHz  |
| Sideband Spectrum               | ± 30 kHz 90 dB below carrier<br>± 1 MHz 105 dB below carrier  |
| Hum and Noise                   | 55 dB below 60% deviation @1 kHz  |
| Audio Response                  | +1, -3 dB from 6 dB/octave, 300-3000 Hz, referenced to 1000 Hz  |
| Spurious: Conducted<br>Radiated | 85 dB below carrier<br>-13 dBm (dipole substitution method)   |
| Audio Distortion                | Less than 2% @1000 Hz, 60% system deviation   |

\*Available with option C601, C602, C603, or C604.

**technical writing services**

## 1. GENERAL

The 110 watt intermittent duty and 100 watt continuous duty transmitters used in the Motorola *MSR 2000* VHF Base Station consist of the exciter board, mounted in the rf control chassis, and the power amplifier enclosed in a casting mounted at the top of the cabinet.

## 2. EXCITER

**2.1** Two versions of the exciter are available. The TLD9230A Series Simplex Exciter is intended for use with stations operating in simplex (nonsimultaneous transmit/receive) mode. The TLD9240A Series Duplex Exciter contains additional interconnection filtering, and is intended for use with stations operating in duplex mode, i.e., repeater stations.

**2.2** The exciter board is easily accessed for alignment by swinging the rf control chassis out and down. Refer to the Maintenance section of this manual for service access procedures.

## 3. POWER AMPLIFIER

The TLD2532A and TLD2600A Series Power Amplifiers consist of the power amplifier board, power control board, and harmonic filter, mounted in a rugged aluminum casting. All circuitry is fully shielded, and is easily accessed for alignment and servicing without removing the PA chassis from the base station. Refer to the Maintenance section of this manual for service access procedure.

## 4. ALIGNMENT

The transmitter alignment procedure involves adjustments on the exciter board and on the power control board. The alignment procedure given is for use with the Motorola TEK-5 Meter Panel, S1056B Test Set, or optional station metering (TRN5080A DC Metering Chassis). When performing a complete alignment, perform the alignment procedures (exciter/PA/power control, oscillator frequency, deviation) in the order given.



**INTERMITTENT DUTY**  
TRANSMITTER FUNCTIONAL INTERCONNECT DIAGRAM

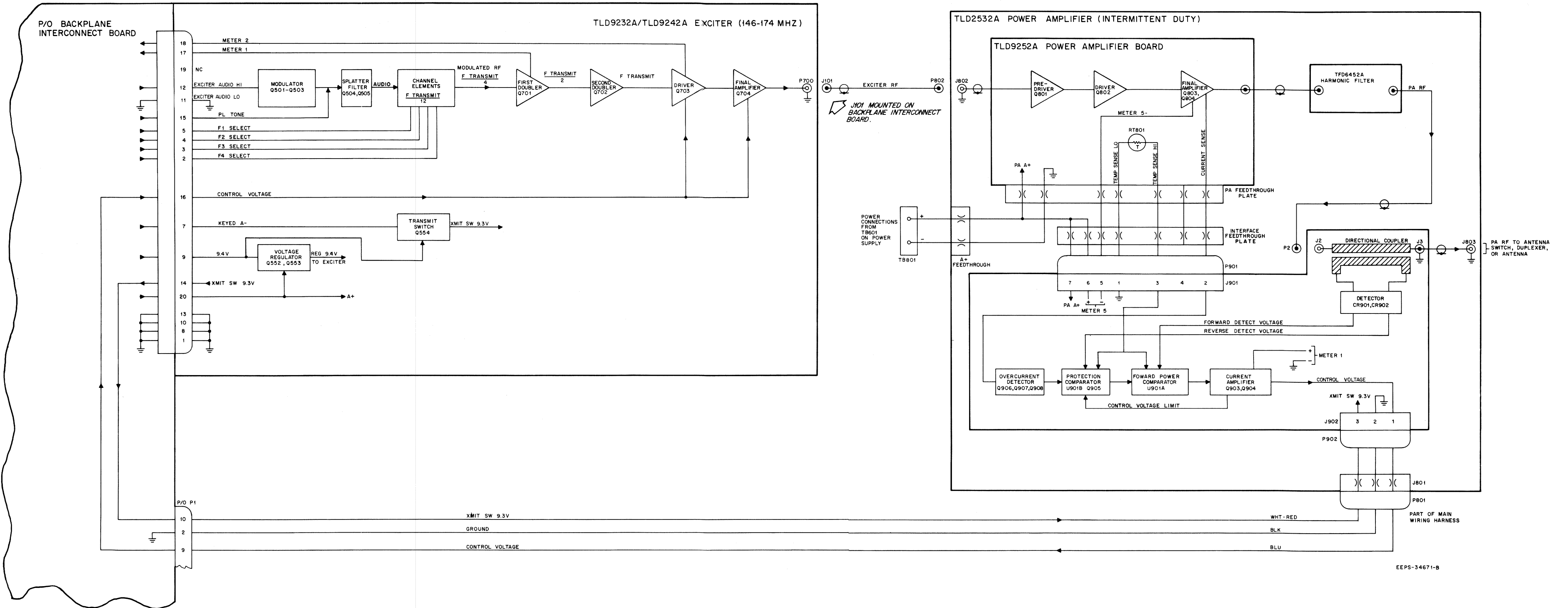

**CONTINUOUS DUTY**  
**TRANSMITTER FUNCTIONAL INTERCONNECT DIAGRAM**

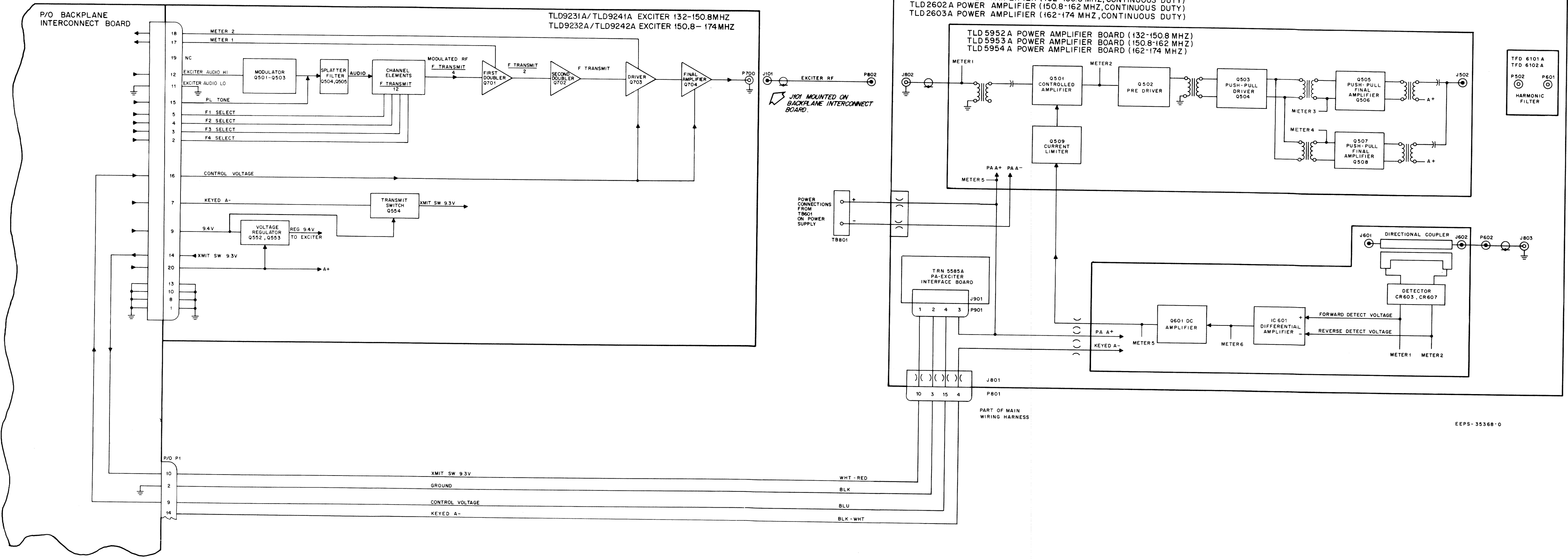

EEPS-35368-0

# INTERMITTENT DUTY TRANSMITTER ALIGNMENT

## NOTE

The tuning procedure should be performed using the TRN5080A DC Metering Chassis, Motorola TEK-5 Meter Panel (set to position "D" for exciter or "E" for PA) or Motorola S1056-1059 Portable Test Set (used with TEK-37A Test Set Adapter).

## CAUTION

Do not key transmitter for more than a few seconds at a time until it is properly tuned. Key transmitter for brief periods while reading meter and making adjustments.

### Exciter-PA Alignment Procedure

| Step   | Metering Cable Connection  | Test Switch Position (Meter) | Adjustment                   | Procedure   |
|--|----------------------------|------------------------------|------------------------------|---|
| 1  | None                       | None                         | Frequency Select             | Set to lowest frequency transmit channel (multi-channel radios only).   |
|  |                            |                              | L701-L708                    | See Preset table  |
|  |                            |                              | R911,R931, R939              | Set fully clockwise.  |
|  |                            |                              | C759                         | Preset fully clockwise  |
| 2  | Exciter                    | M1                           | L701, L702, L703             | Peak L702, then peak L701, L702, L703 in order until no further improvement is obtained.  |
| 3  | Exciter                    | M1                           | L704, L705                   | Dip L704, peak L705.  |
| 4  | Exciter                    | M2                           | L706, L707, L708, L704, L705 | Peak L706, L707, L708, L704, L705 in order.   |
| If tuning 1-frequency transmitter, or if overall channel separation is less than 500 kHz, skip to Step 12. |                            |                              |                              |   |
| 5  | Exciter                    | M1                           | L702                         | Peak on highest frequency channel.  |
| 6  | Exciter                    | M2                           | L704,L706                    | Peak on highest frequency channel.  |
| 7  | Exciter                    | M1                           | L701,L702                    | Peak on lowest frequency channel.   |
| 8  | Exciter                    | M2                           | L705, L707                   | Peak on lowest frequency channel.   |
| 9  | Transmit Antenna Connector | Wattmeter                    | C759                         | Adjust for highest power output at the lowest frequency. If a definite peak is not evident, i.e. if the same amount of power is obtained over a wide range of tuning of C759, turn R931 counterclockwise until output power drops by 10 watts then peak C759. |
| 10   | Exciter                    | Wattmeter and M2             | L708                         | See R931 fully clockwise. Adjust L708 for equal M2 readings on highest and lowest frequency channels. If balanced M2 readings are not possible, peak L708 on channel with lowest M2 reading.  |
| 11   | Go to Step 15              |                              |                              |   |
| 12   | Transmit Antenna Connector | Wattmeter                    | C759                         | Adjust for highest possible power output.   |
| 13   | Exciter                    | M2                           | L707,L708                    | Peak.   |
| 14   | Transmit Antenna Connector | Wattmeter                    | C759                         | Adjust for highest possible power output. If a definite peak is not evident, i.e. if the same amount of power is obtained over a wide range of turning of C759, turn R931 counterclockwise until power output drops by 10 watts, then peak C759.              |
| 15   | Transmit Antenna Connector | Wattmeter                    | R931, R911                   | Set R931 fully clockwise. Adjust R911 for 120 watts rf output (any channel).  |
| 16   | Power Control Board J1     | M1,M5                        | Frequency Select             | On each channel note M1 and M5 readings for reference.  |
| 17   | Power Control Board J1     | M1                           | R911,R931                    | Adjust R911 fully clockwise. On the channel with the highest initial M1 reading, adjust R931 for a reading 4 uA above that recorded in step 16.   |
| 18   | Power Control Board J1     | M5                           | R939                         | On the channel with the highest M5 reading, adjust for reading 2 uA above M5 reading recorded in Step 16. If a full 2 uA rise cannot be obtained, return R939 fully clockwise, read M5, and adjust R939 for a 0.5 uA drop in M5 reading.                      |
| <b>NOTE</b>  |                            |                              |                              |   |
| Disconnect test set metering cables before performing Step 19.   |                            |                              |                              |   |
| 19   | Transmit Antenna Connector | Wattmeter                    | R911                         | Adjust R911 so that minimum power output is 120 watts on all channels.  |

## OSCILLATOR FREQUENCY ADJUSTMENT

Setting oscillator frequency should be done *after* exciter/power amplifier alignment, but *before* transmitter deviation is set. To set oscillator on frequency, perform the following procedure:

Step 1. Select transmitter operating frequency F1. Connect frequency meter to antenna connector via dummy load (refer to instructions provided with meter).

Step 2. Key transmitter with no modulation.

## NOTE

On stations equipped with *Private-Line* or *Digital Private-Line* signaling, the PL/DPL encoder must be disabled. This is accomplished by grounding pin 14 of the PL/DPL board position on the backplane interconnect board.

Step 3. Adjust F1 FREQ control for proper reading on frequency meter. If the frequency, as indicated on the frequency meter is too low, turn the control counterclockwise. If the frequency is too high, turn the control clockwise. Set frequency within  $\pm 75$  Hz.

## NOTE

Omit Steps 4 and 5 for 1-frequency stations.

Step 4. Select transmitter operating frequency F2, and repeat Step 3 using F2 FREQ control.

Step 5. Repeat Step 4 for F3 and F4 using F3 FREQ and F4 FREQ controls respectively.

## INSTANTANEOUS DEVIATION CONTROL (IDC) ADJUSTMENT

## NOTE

The oscillator frequency adjustment must be made prior to this adjustment.

Step 1. Connect the output leads of an audio oscillator, through a .33 uF capacitor, to exciter pins 12 (EXCITER AUDIO HI) and 11 (EXCITER AUDIO LO).

Step 2. Connect an ac voltmeter across the same terminals and adjust the audio oscillator output to 350 mV rms at 1000 Hz.

Step 3. Key transmitter and adjust F1 IDC while observing deviation monitor. Adjust control for 4.7 kHz deviation.

Step 4. Repeat Step 3 for each frequency used, adjusting IDC adjustment corresponding to each channel.

## NOTE

If radio set transmits *Private-Line* or *Digital Private-Line* signals, PL/DPL deviation with audio oscillator disconnected should now be between 0.5 and 1.0 kHz.

## COIL PRESET CHART

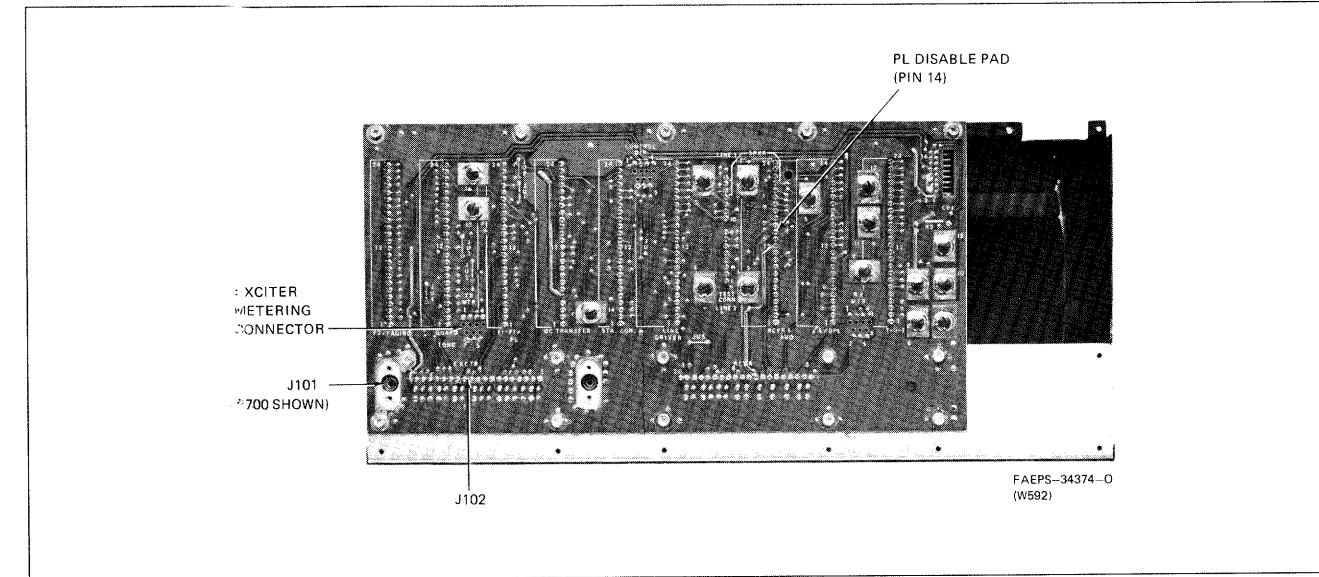
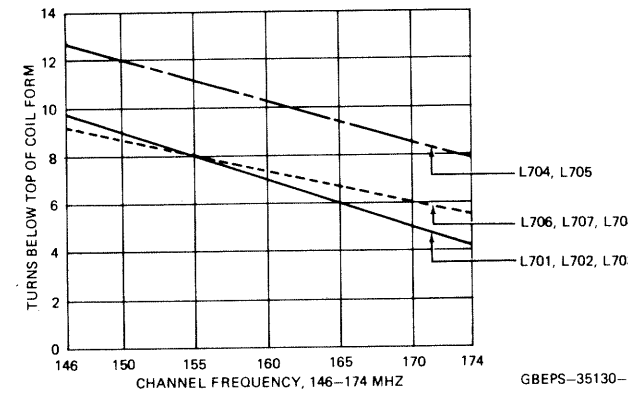

Figure 1. Basic Chassis Exciter Metering Connection Detail

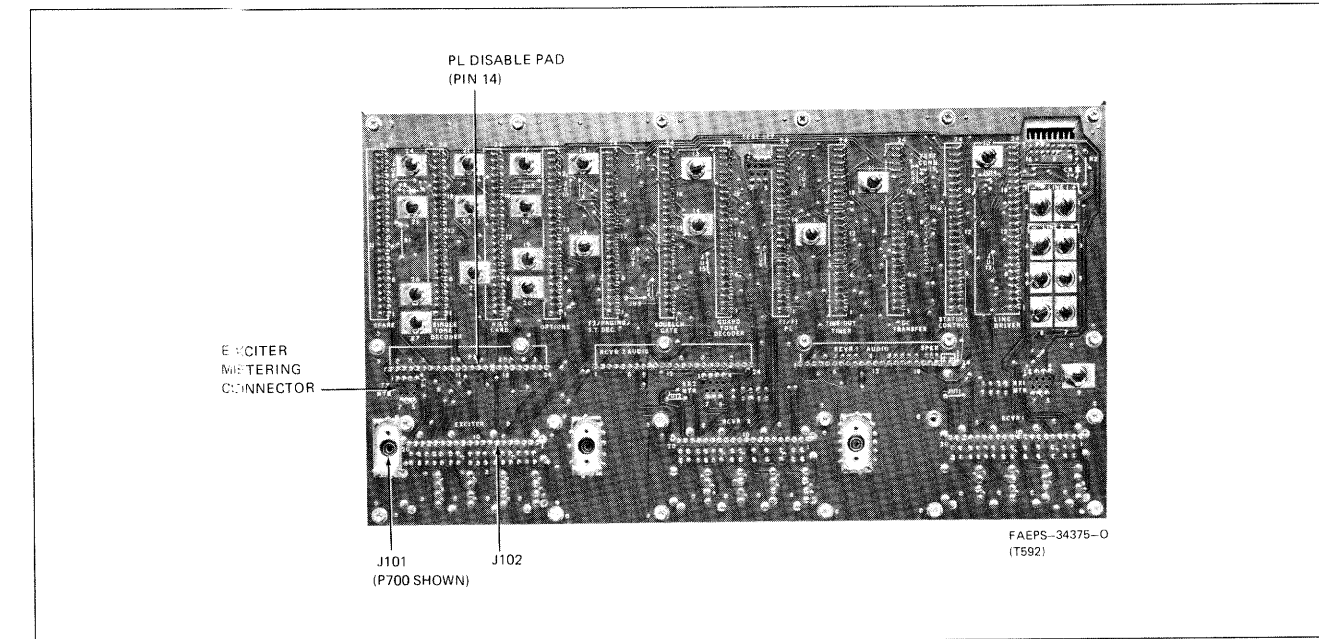

Figure 2. Fully Optionable Chassis Exciter Metering Connection Detail

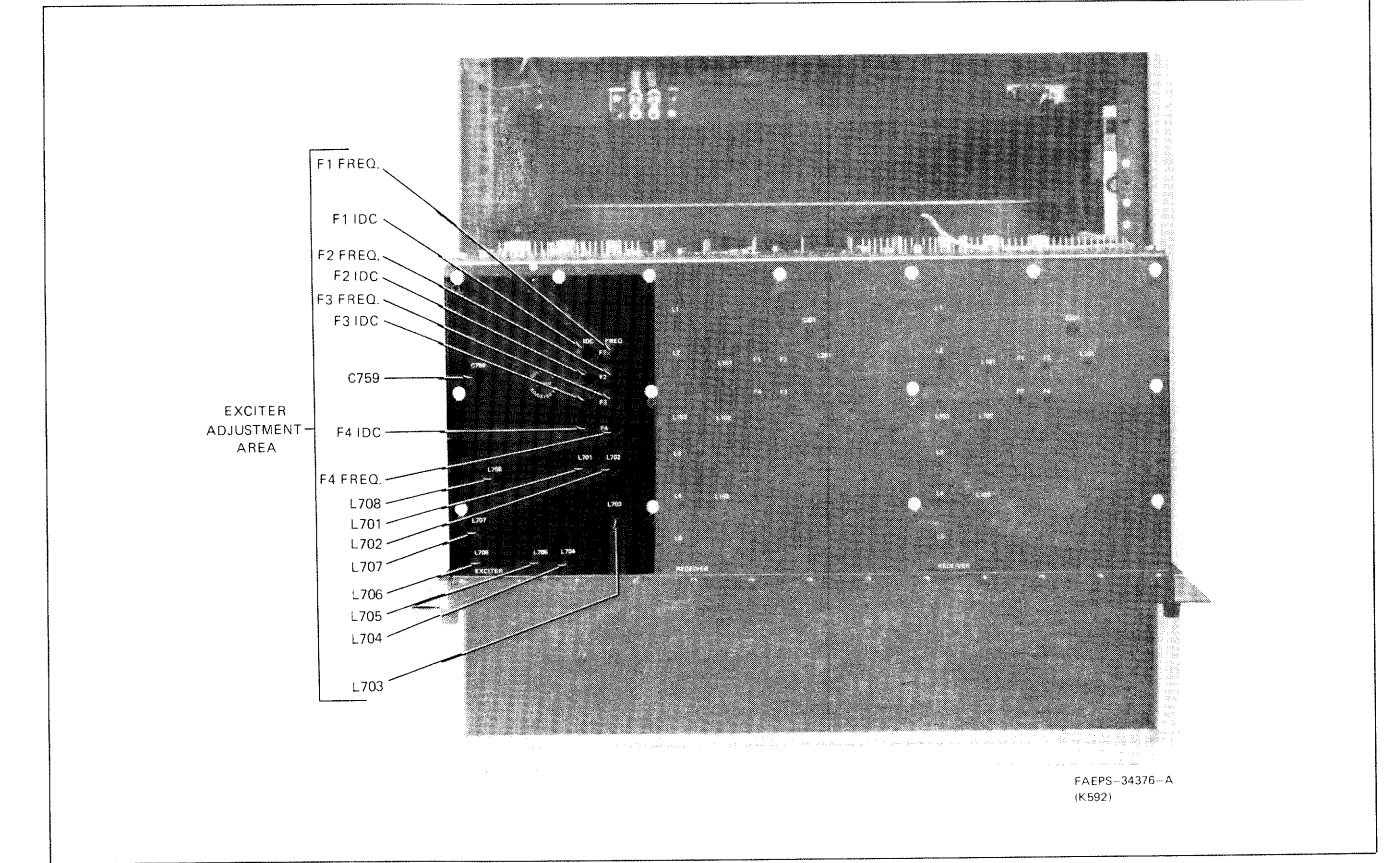

Figure 3. Exciter Adjustment Location Detail

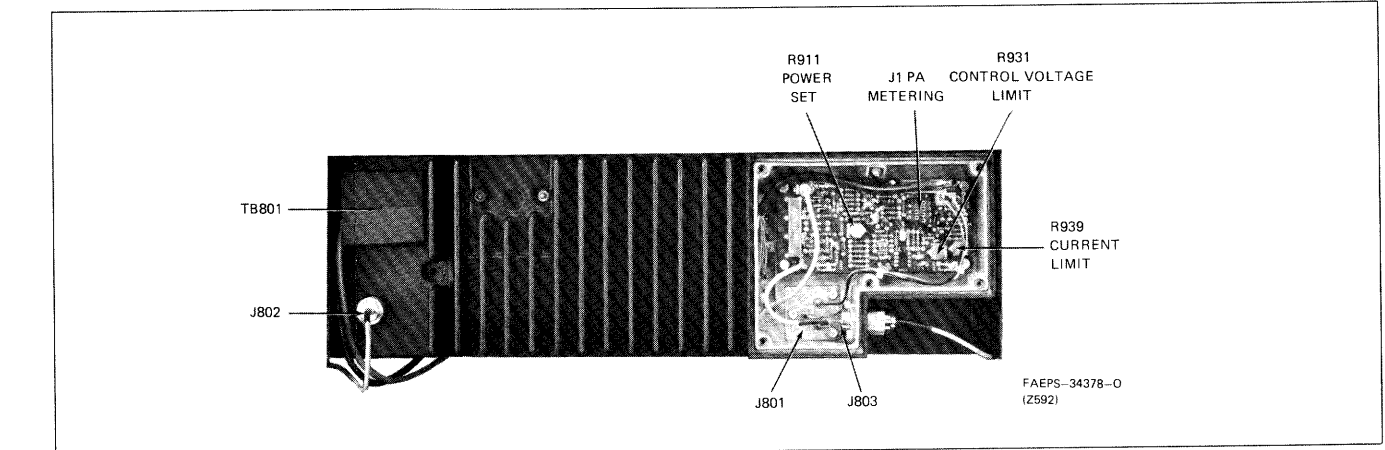
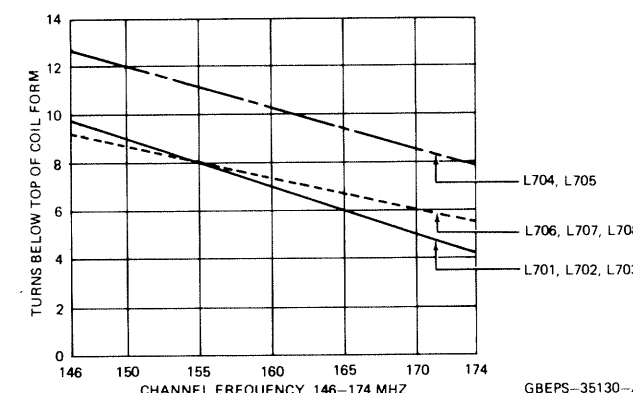
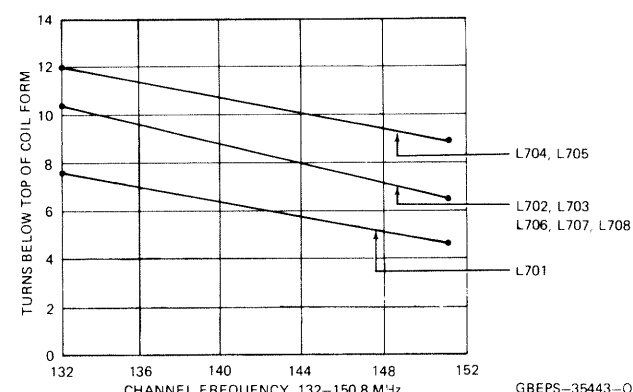

Figure 4. PA Adjustment Location Detail

## COIL PRESET CHARTS



### NOTE

The tuning procedure should be performed using the TRN5080A DC Metering Chassis, Motorola TEK-5 Meter Panel (set to position "D" for exciter, "C" for PA, and "E" for Power Control) or Motorola S1056-1059 Portable Test Set (used with TEK-37A Test Set Adapter).

### CAUTION

Do not key transmitter for more than a few seconds at a time until it is properly tuned. Key transmitter for brief periods while reading meter and making adjustments.

### Exciter-PA Alignment Procedure

| Step   | Metering Cable Connection | Test Switch Position (Meter) | Adjustment                              | Procedure  |
|--|---------------------------|------------------------------|---|--|
| 1  | None                      | None                         | Frequency Select                        | Turn the FREQUENCY SELECT switch to the lowest frequency channel.  |
|  |                           |                              | L701, L702, L703                        | Preset coil slugs per coil preset chart.   |
|  |                           |                              | L704, L705                              | Preset coil slugs per coil preset chart.   |
|  |                           |                              | L706, L707, L708                        | Preset coil slugs per coil preset chart.   |
|  |                           |                              | C759                                    | Preset fully clockwise (CW).   |
|  |                           |                              | R611 — Power Set on Power Control Board | Preset fully counterclockwise (CCW).   |
| 2  | Exciter                   | M1                           | L701, L702, L703                        | Peak L702, then peak L701, L702, L703 in order until no further improvement is obtained.   |
|  |                           |                              | L704, L705                              | Dip L704, then peak L705.  |
| 3  | Exciter                   | M1                           | L704, L705                              | Dip L704, then peak L705.  |
| 4  | Exciter                   | M2                           | L706, L707, L708, L704, L705            | Peak L706, L707, L708, L704, and L705 in that order.   |
| If transmitter is to be tuned for a single frequency, or frequencies with a separation of less than 500 kHz, skip to Step 12.    |                           |                              |   |  |
| 5  | None                      | None                         | Frequency Select                        | Turn the FREQUENCY SELECT switch to the highest channel frequency.   |
| 6  | Exciter                   | M1                           | L702                                    | Peak L702.   |
| 7  | Exciter                   | M2                           | L704, L706                              | Peak L704 and L706.  |
| 8  | None                      | None                         | Frequency Select                        | Turn the FREQUENCY SELECT switch to the lowest channel frequency.  |
| 9  | Exciter                   | M1                           | L701, L703                              | Peak L701 and L703.  |
| 10   | Exciter                   | M2                           | L705, L707                              | Peak L705 and L707.  |
| 11   | Power Amplifier           | M1                           | C759                                    | Peak C759 (Exciter). If M1 is greater than 50 uA, reduce exciter control voltage (R901) until a peak can be obtained.  |
| 12   | Exciter (pin 16)          | Voltmeter                    | R901                                    | Set control voltage according to Table 1.  |
| If the transmitter is to be tuned for a single frequency or frequencies with a separation of less than 500 kHz, skip to Step 15. |                           |                              |   |  |
| 13   | Exciter                   | M2                           | L708                                    | Adjust L708 for equal M2 readings on the lowest channel frequency and on the highest channel frequency. If M2 cannot be equalized, peak L708 on the channel with the lowest 2 reading.   |
| 14   | Power Amplifier           | M1                           | C759                                    | Peak C759 (exciter) on the lowest channel frequency. If M1 is greater than 50 uA, reduce the exciter control voltage (R901) until a peak is observed. After peaking C759, reset exciter control voltage to the value in Step 12. Then go to Step 17.   |
| 15   | Exciter                   | M2                           | L707, L708                              | Peak L707 and L708.  |
| 16   | Power Amplifier           | M1                           | C759                                    | Peak C759 (exciter). If M1 is greater than 50 uA, reduce the exciter control voltage (R901) until a peak can be observed. After peaking C759, reset exciter control voltage to the value in Step 12.   |
| 17   | Power Amplifier           |                              | R611                                    | If power amplifier is to be re-aligned greater than ±1 MHz from original frequency proceed with Step 18. If power amplifier is to be re-aligned less than ±1 MHz from original frequency, remove power control board shield, move metering plug to power control board. Set R611, Power Set, fully clockwise (CW) and go to Step 22. |

### Exciter-PA Alignment Procedure (Cont'd.)

| Step   | Metering Cable Connection | Test Switch Position (Meter) | Adjustment       | Procedure  |
|--|---------------------------|------------------------------|------------------|--|
| 18   | Power Amplifier           |                              | C501, C502, R610 | REALIGNMENT—Set cap. C501 fully clockwise. Set cap. C502 to maximum capacity (plates fully meshed). Remove power control board shield and move metering plug to power control board. Use tuning tool Motorola No. 66A82846D01 or equivalent to prealign POWER LIMIT control R610, located on the component side of the board. Access to this control is provided by a small slot located approximately 3/4" from the POWER SET access hole. The tuning tool rotates the outer edge of a serrated knob. Adjust R610, the POWER LIMIT control, to the end of its travel by rotating the edge of the knob toward the front of the station with the PA in the tilted out position. |
| 19   | Power Control Board       |                              | R611             | TRANSMITTER OUTPUT—Adjust R611 (POWER SET) control to maximum clockwise (CW) position.   |
| 20   | Power Control Board       | M5                           | C501             | PA (DRIVER) OUTPUT—Observe M5. If this indication is less than 50 uA (full scale), proceed with Step 21. If this indication is greater than 50 uA tune C501 for on-scale reading.  |
| 21   | Power Control Board       | Wattmeter                    | R610             | TRANSMITTER OUTPUT—Adjust R610 (POWER LIMIT control) toward back of station until no further increase in power output is observed. Adjust POWER LIMIT control for an approximate 5 W to 10 W reduction to obtain an unsaturated meter 5 reading.   |
| 22   | Power Control Board       | M5                           | C501, C502       | PA DRIVER OUTPUT—Tune C501 then C502 for a minimum M5 reading.   |
| <b>NOTE</b><br>Repeat Steps 21 and 22 until no further dip in meter 5 can be obtained. |                           |                              |                  |  |
| 23   | Power Control Board       | Wattmeter                    | R610             | TRANSMITTER OUTPUT—Adjust the POWER LIMIT control (R610) for 115 W.  |
| 24   | Power Control Board       | M5 Wattmeter                 | R610             | Replace the power control board shield. If M5 exceeds 50 uA when shield is replaced, remove shield and adjust POWER LIMIT control (R610) slightly (turn knob toward front of station) until an on-scale reading (50 uA or less) is observed when shield is replaced. Power output shall be at least that specified in Step 23.   |
| 25   | Power Control Board       | Wattmeter                    | R611             | TRANSMITTER OUTPUT—Remove the meter cable and adjust POWER SET control (R611) for rated power output.  |
| 26   | Power Amplifier           | M5                           |                  | FINAL COLLECTOR CURRENT—Move the metering plug to the PA. Measure the final collector current (Ic). Ic, in amperes is the M5 reading: (0-50) × 1/2.  |

This completes transmitter tuning. Refer to Table 2 for metering limits.

## OSCILLATOR FREQUENCY ADJUSTMENT

Setting oscillator frequency should be done after exciter/power amplifier alignment, but before transmitter deviation set. To set oscillator on frequency, perform the following procedure:

Step 1. Select transmitter operating frequency F1. Connect frequency meter to antenna connector via dummy load (refer to instructions provided with meter).

Step 2. Key transmitter with no modulation.

### NOTE

On stations equipped with Private-Line or Digital Private-Line signaling, the PL/DPL encoder must be disabled. This is accomplished by grounding pin 14 of the PL/DPL board position on the backplane interconnect board.

Step 3. Adjust F1 FREQ control for proper reading on frequency meter. If the frequency, as indicated on the frequency meter is too low, turn the control counterclockwise. If the frequency is too high, turn the control clockwise. Set frequency within ±75 Hz.

### NOTE

Omit Steps 4 and 5 for 1-frequency stations.

Step 4. Select transmitter operating frequency F2, and repeat Step 3 using F2 FREQ control.

Step 5. Repeat Step 4 for F3 and F4 using F3 FREQ and F4 FREQ controls respectively.

## INSTANTANEOUS DEVIATION CONTROL (IDC) ADJUSTMENT

### NOTE

The oscillator frequency adjustment must be made prior to this adjustment.

Step 1. Connect the output leads of an audio oscillator, through a .33 uF capacitor, to exciter pins 12 (EXCITER AUDIO HI) and 11 (EXCITER AUDIO LO).

Step 2. Connect an ac voltmeter across the same terminals and adjust the audio oscillator output to 350 mV rms at 1000 Hz.

Step 3. Key transmitter and adjust F1 IDC while observing deviation monitor. Adjust control for 4.7 kHz deviation.

Step 4. Repeat Step 3 for each frequency used, adjusting IDC adjustment corresponding to each channel.

### NOTE

If radio set transmits Private-Line or Digital Private-Line signals, PL/DPL deviation with audio oscillator disconnected should now be between 0.5 and 1.0 kHz.

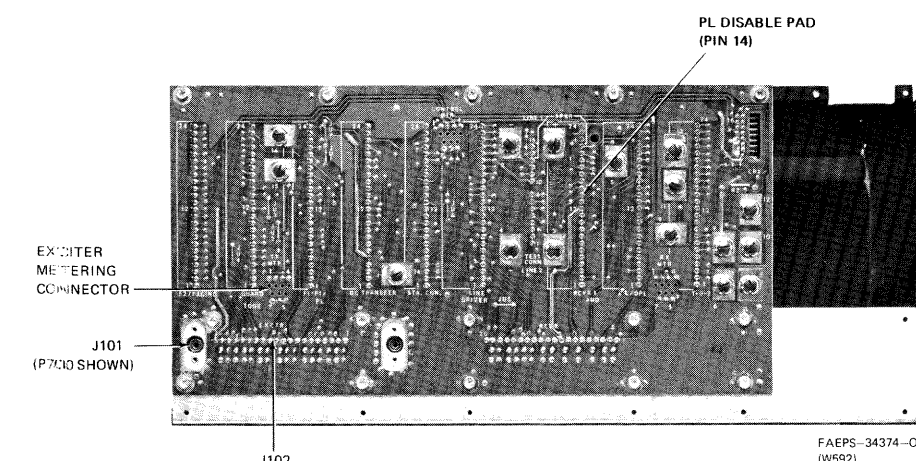

Figure 1. Basic Chassis Exciter Metering Connection Detail

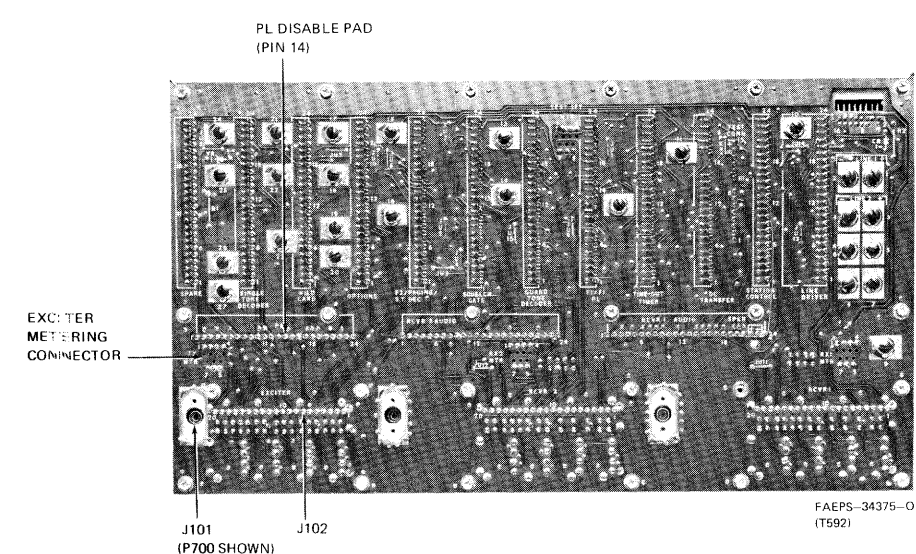

Figure 2. Fully Optionable Chassis Exciter Metering Connection Detail

## CONTINUOUS DUTY TRANSMITTER ALIGNMENT

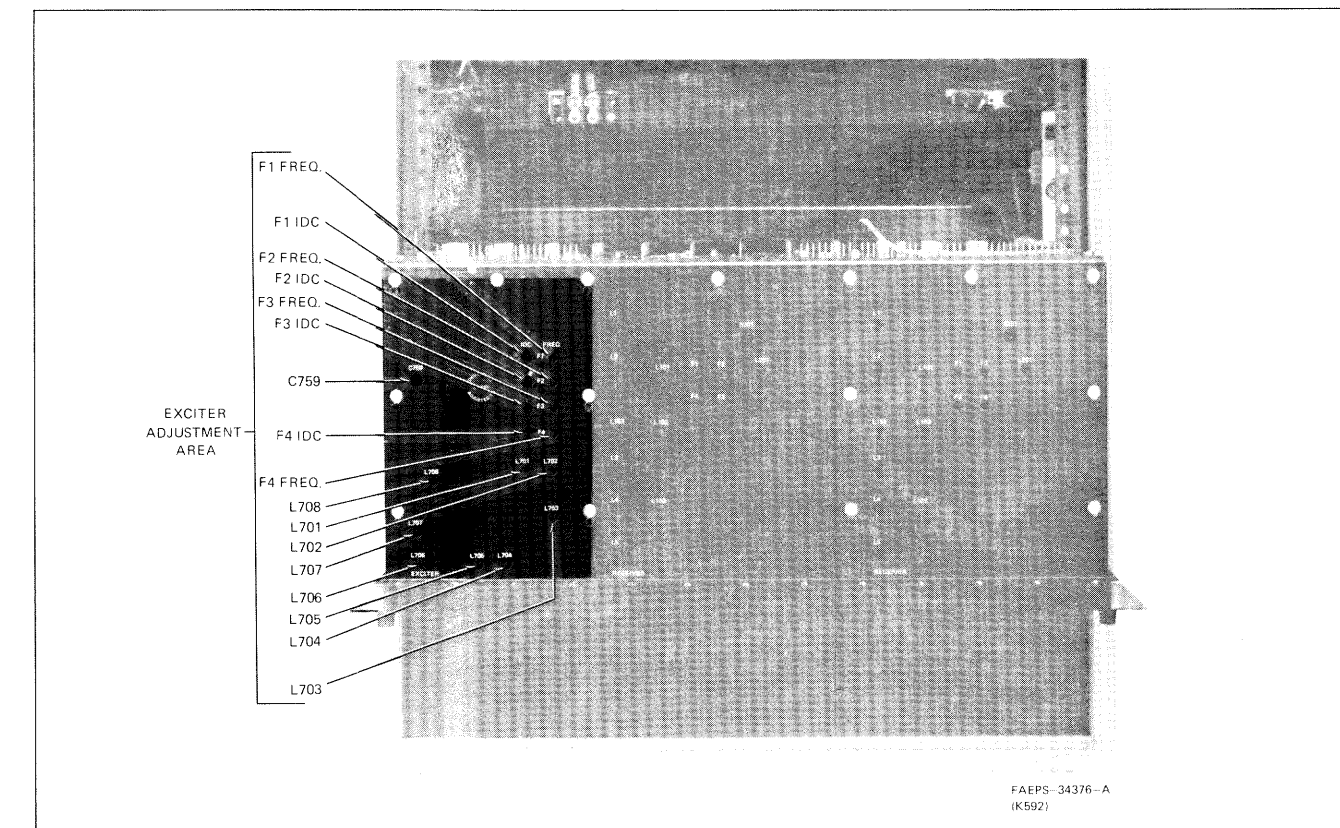

Figure 3. Exciter Adjustment Location Detail

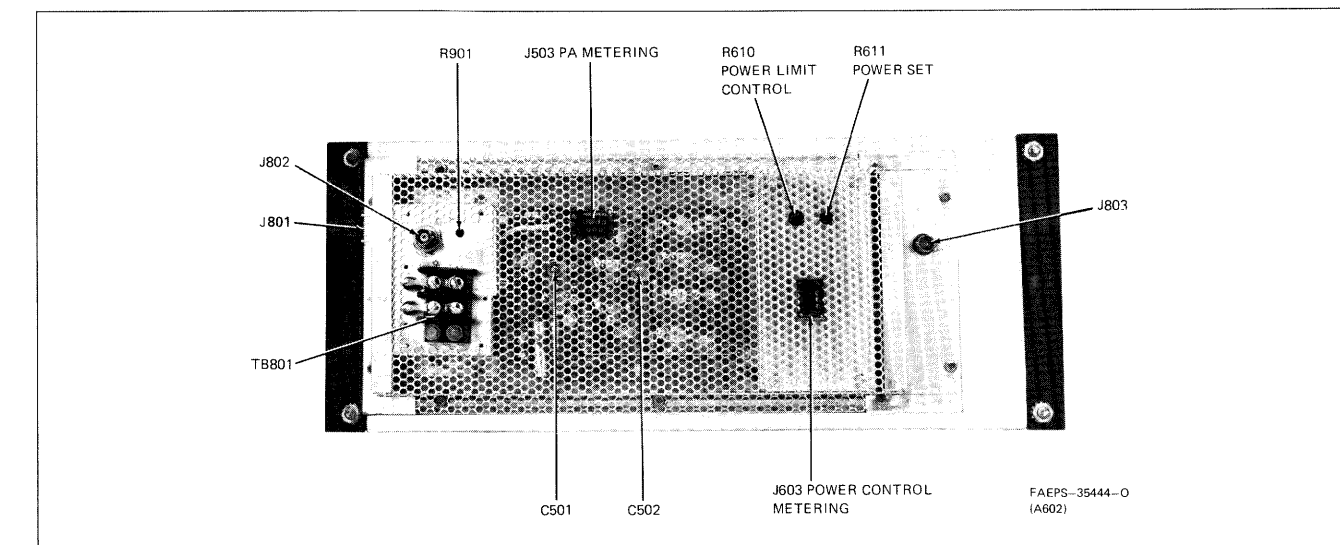

Figure 4. PA Adjustment Location Detail

Continuous Duty Transmitter Alignment Motorola No. PEPS-35367-A 9/30/85-UP

Table 1. Control Voltage Set (R901)

| Model                    | Frequency (MHz) | Voltage* |
|--------------------------|-----------------|----------|
| TLD9231A or TLD9241A     | 132-141         | 5.5 V    |
|                          | 141-150.8       | 6.0 V    |
| TLD9232A/B or TLD9242A/B | 146-160         | 6.0 V    |
|                          | 160-174         | 6.5 V    |

\*Voltage is measured at pin 16 of exciter.

Table 2. Meter Limit Specifications

| Metering Cable Connection | Test Switch Position (Meter) | Min (uA) | Max (uA) |
|---------------------------|------------------------------|----------|----------|
| Exciter                   | M1                           | 10       | 50       |
| Exciter                   | M2                           | 15       | 50       |
| Power Amplifier           | M1                           | 10       |          |
| Power Amplifier           | M2                           | 5        |          |
| Power Amplifier           | M3                           | 10       |          |
| Power Amplifier           | M4                           | 10       |          |
| Power Amplifier           | M5                           | 29       |          |
| Power Control Board       | M1                           | 15       | 45       |
| Power Control Board       | M2                           | 10       |          |
| Power Control Board       | M5                           | 10       | 50       |

\* Limit specifications are applicable after the transmitter has been aligned and is operating into a 50 ohm load.



---

---

---

---

---

---

## 1. DESCRIPTION

**1.1** The Model TLD9230 Series or TLD9240 Series Exciters provide the low power excitation for the FM transmitter. Up to four plug-in channel elements, one for each transmitter operating frequency, are used to develop a direct FM carrier signal of at least 1.5 watts.

**1.2** The exciter is direct frequency-modulated for crystal-controlled frequency operation in the 132-174 MHz range. It consists of a modulator amplifier and clipper, emitter-follower splatter filter, channel element(s) (voltage-controlled crystal oscillator), first doubler, second doubler, driver, and final amplifier. The fundamental crystal frequency is multiplied by twelve to provide the transmitter carrier frequency.

**1.3** When the exciter is used in PL/DPL coded stations, the PL/DPL encoding signals are inserted into the transmit audio at the input to the splatter filter stage.

## 2. THEORY OF OPERATION

Refer to the transmitter functional block diagram (in Transmitter section of this manual) and the exciter schematic diagram included in this section.

### 2.1 TRANSMIT AUDIO CIRCUIT

Exciter audio from the station control module (or test microphone) is applied to audio amplifier Q501, then routed to the clipper/pre-emphasis circuit of Q502 and Q503. This amplitude limited audio is combined with the PL or DPL code audio (if present) and routed via active splatter filter Q504-Q505, to the channel element(s).

### 2.2 CHANNEL ELEMENTS

**2.2.1** Each channel element is comprised of a highly stable, frequency modulated crystal controlled oscillator. The channel element is a factory-sealed plug-in module, using an unheated crystal in an oscillator circuit that is temperature-compensated over an ambient

temperature range of  $-30^{\circ}\text{C}$  to  $+60^{\circ}\text{C}$  ( $-22^{\circ}\text{F}$  to  $+140^{\circ}\text{F}$ ). The oscillator operates at 1/12 of the transmitted carrier frequency.

**2.2.2** The channel element contains a series combination of a varactor diode, a warping coil, and the crystal. A change in the series inductance or capacitance causes the crystal to vary its resonant frequency in proportion to the change. The audio voltage from the IDC circuitry (within the channel element) is applied to the varactor diode to cause a change in capacitance; this variation causes the carrier frequency to change (deviate) at the same audio rate. The variable warp coil and IDC potentiometer are accessible through holes in the top of each channel element, for fine frequency and IDC adjustments.

**2.2.3** The exciter accepts up to four channel elements; one is required for each transmit frequency. A power input of +9.4 volts is applied continuously to all channel elements while the station is turned on. Channel element output is developed when a switched ground from the station control module is routed to the enable pin.

### 2.3 MULTIPLIERS AND AMPLIFIERS

**2.3.1** The multipliers develop an output signal that is 12 times the channel element frequency, and the final amplifier provides power gain, as controlled by the power control board on the power amplifier.

**2.3.2** The output of the activated channel element is routed through three tuned circuits in series. The tuned circuits (L701, L702, L703, and associated components) are tuned to the approximate third harmonic of the channel element frequencies. The signal from the tuned circuit is routed to first doubler Q701. First doubler Q701 and second doubler Q702 multiply the filtered output to 12 times the crystal frequency.

**2.3.3** Driver and final amplifier Q703 and Q704 provide two stages of amplification at the transmit frequency. The power output level of the driver and final amplifier is controlled by varying the dc collector volt-

age on the transistors. For intermittent duty stations, the CONTROL VOLTAGE is developed on the power control board in the power amplifier. The CONTROL VOLTAGE changes as required to maintain correct PA output level and operating parameters. For continuous duty stations, the CONTROL VOLTAGE is developed on the exciter control voltage regulator board. The CONTROL VOLTAGE is set by the Exciter Level Control (R901).

### 3. EXCITER FUNCTIONAL TESTS

The tests in this section should be performed *after* servicing but *before* alignment, to verify that the exciter circuitry is operating correctly.

#### 3.1 EXCITER POWER OUTPUT TEST

##### 3.1.1 Intermittent Duty Station

Step 1. Disconnect exciter output cable from power amplifier chassis, and connect to rf wattmeter and dummy load.

Step 2. Set Power Set (R911) and Current Limit (R939) controls to mid-rotation. These controls are located on the power control board in the PA chassis. (Refer to Power Amplifier section for exact location.)

Step 3. Set Control Voltage Limit (R931) fully clockwise. This control is also located on the power control board.

Step 4. Key transmitter and observe wattmeter. Power output is normally at least 1.5 watts.

##### 3.1.2 Continuous Duty Station

Step 1. Disconnect exciter output cable from power amplifier chassis, and connect to rf wattmeter and dummy load.

Step 2. Set Exciter Level Control (R901) fully clockwise (CW). This control is located on the power amplifier.

Step 3. Key the transmitter and observe the wattmeter. Power output is normally at least 0.75 watts.

#### 3.2 FREQUENCY TEST

Step 1. Terminate the transmitter in an antenna or dummy load and measure the radiated signal frequency with a Motorola digital frequency meter or other highly accurate frequency measuring device ( $\pm .00005\%$  or better) when the transmitter is keyed in the following steps.

Step 2. Key the transmitter to produce an unmodulated carrier signal. In stations equipped with PL or DPL signaling, disable the encoder by shorting the disable pin to ground (pin 14 on the PL/DPL position on the backplane interconnect board).

##### NOTE

Do not use microphone push-to-talk switch to key station. Background noise can modulate the transmitter.

Step 3. Read transmitter output frequency. Repeat for each channel on multi-frequency stations.

#### 3.3 DEVIATION TEST

Step 1. Terminate transmitter with an antenna or dummy load and measure the radiated signal deviation using a Motorola deviation monitor when the transmitter is keyed in the following steps.

Step 2. (PL/DPL models only.) Remove PL/DPL inhibit jumper (if installed during previous test). Key transmitter without voice modulation. Normal PL/DPL deviation is 0.5 to 1 kHz.

Step 3. Connect audio oscillator to exciter board pins P501-12 (EXCITER AUDIO HI) and P501-11 (EXCITER AUDIO LO). Set audio oscillator to 1000 Hz at 350 mV rms output. Normal deviation is 4.7 kHz.

Step 4. Adjust audio oscillator over 300-3000 Hz range, keeping audio level at 1 volt. Normally, deviation never exceeds  $\pm 5$  kHz, nor is less than  $\pm 2.5$  kHz.

### 4. TROUBLESHOOTING

Refer to Table 1 for exciter troubleshooting procedure.

*Table 1. Exciter Troubleshooting Procedure*

| Symptom                | Cause  | Test or Correction  |
|------------------------|--|---|
| No Meter 1 Reading     | 1. Unused or out-of-frequency range channel selected | 1. Ground channel element enable pin for active channel                           |
|                        | 2. No XMIT SWITCHED 9.3 V                            | 2. Check for presence of keyed A-, check or replace Q554                          |
|                        | 3. No REG 9.4 V                                      | 3. Check circuitry of Q552  |
|                        | 4. Bad channel element                               | 4. Try different channel or replace   |
|                        | 5. L701, L702, L703 mis-tuned                        | 5. Perform Exciter/PA Alignment   |
| No Meter 2 Reading     | 1. Bad Q701, Q702, and/or Q703                       | 1. Check and replace  |
|                        | 2. Improper control voltage                          | 2. Troubleshoot PA Power control Board or Exciter Control Voltage Regulator Board |
|                        | 3. L704, L705, L706, L707 and/or L708 mistuned       | 3. Perform Exciter/PA Alignment   |
| Low or No Output Power | 1. Bad Q703 or Q704                                  | 1. Check and Replace  |
|                        | 2. Improper control voltage                          | 2. Troubleshoot PA Power Control Board or Exciter Control Voltage Regulator Board |
|                        | 3. Mis-tuned C759                                    | 3. Retune for highest possible power output                                       |
| Insufficient Deviation | 1. Bad Q501  | 1. Check and replace  |
|                        | 2. Wrong jumpers installed                           | 2. Check that JU501 is out and JU502 is in for non-DVP stations                   |

EARLIER VERSION EXCITER

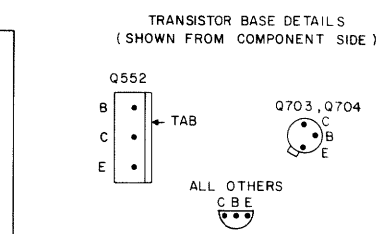
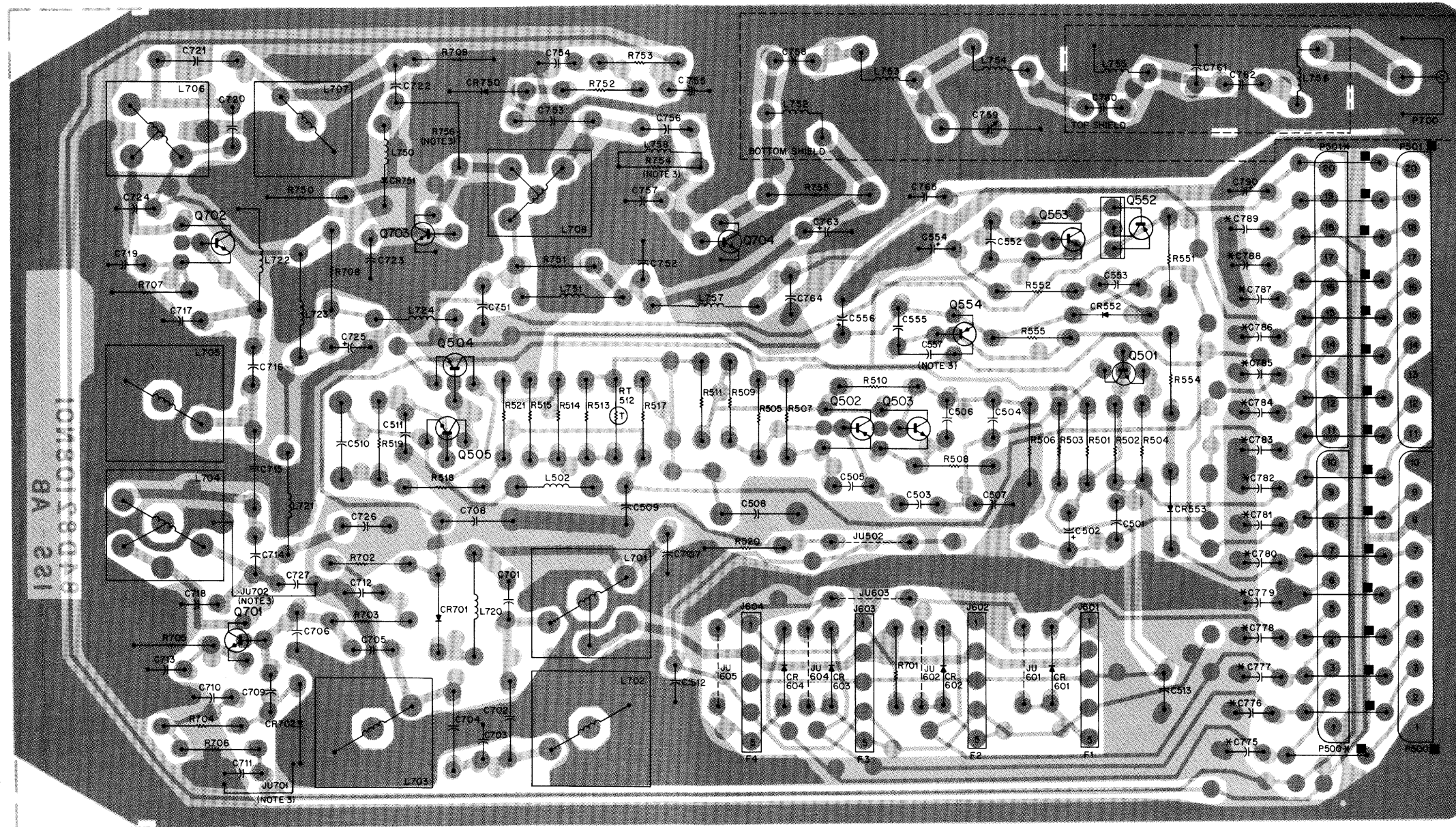

- A\*
- METER 3
- METER 2
- METER 1
- CONTROL VOLTAGE
- PL TONE-DPL CODE
- XMIT SW 9.3V
- GND
- EXCITER AUDIO HI
- EXCITER AUDIO LO
- GND
- 9.4V DC
- GND
- KEYED A-
- NOT USED
- F1 SELECT
- F2 SELECT
- F3 SELECT
- F4 SELECT
- GND

MATES WITH  
BACKPLANE  
EXCITER  
CONNECTOR  
J102

- NOTE:
1. COMPONENTS DESIGNATED WITH ASTERISK (\*) ARE PRESENT ON DUPLEX MODELS (TLD9242C) ONLY.
  2. COMPONENTS AND JUMPERS DESIGNATED WITH SQUARE (■) ARE PRESENT ON SIMPLEX MODELS (TLD9232B) ONLY.
  3. C557, R754, R756, JU701, AND JU702 ARE LOCATED ON SOLDER SIDE.

SHOWN FROM COMPONENT SIDE

SOLDER SIDE: BD-EEPS-34369-0  
COMPONENT SIDE: BD-EEPS-34368-0  
OL-EEPS-34370-B



# CIRCUIT BOARD DETAIL AND PARTS LISTS

## LATER VERSION EXCITER

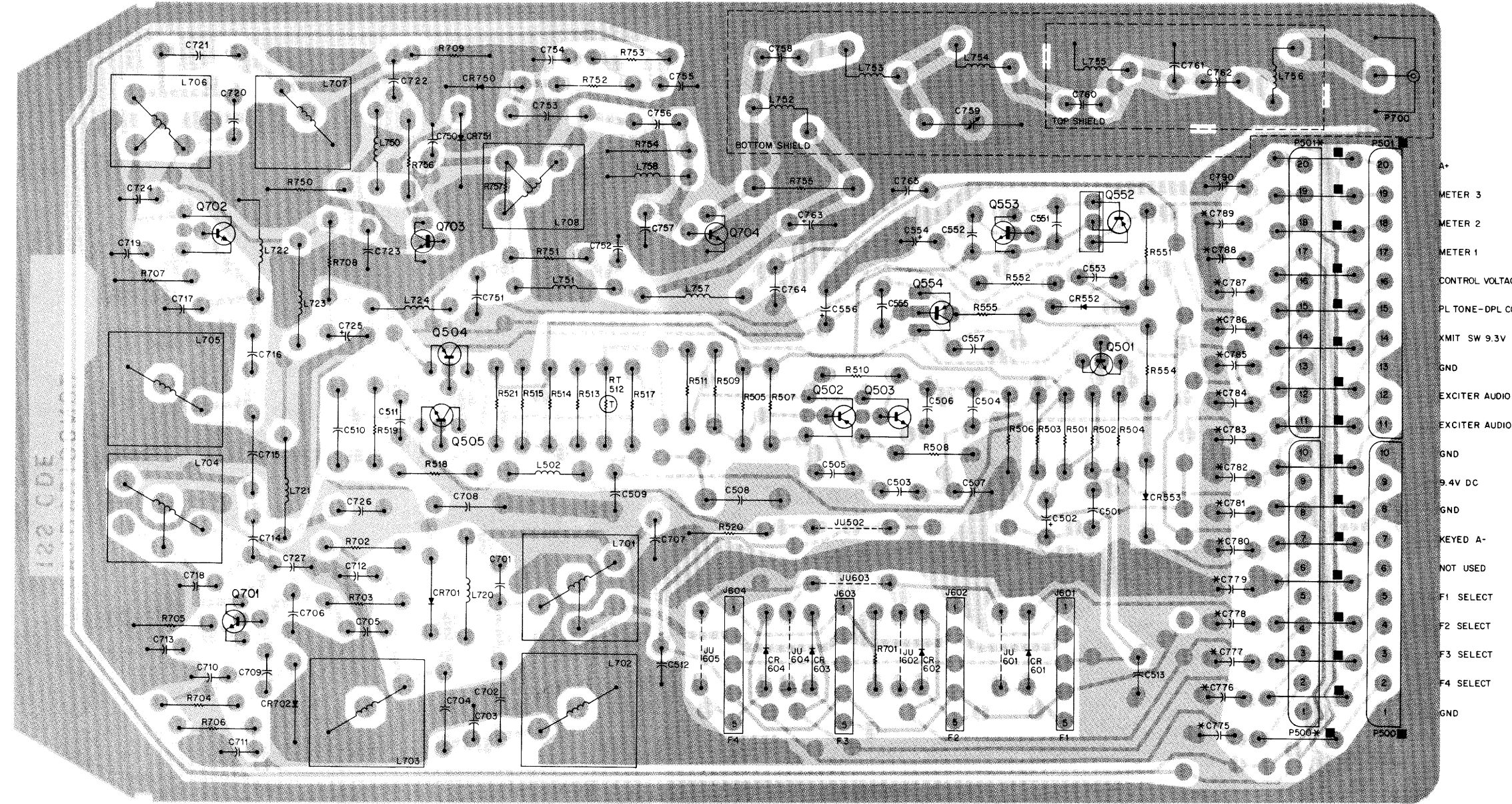

SHOWN FROM COMPONENT SIDE

SOLDER SIDE: BD-DEPS-35241-O  
COMPONENT SIDE: BD-DEPS-35242-O  
OL-EEPS-35243-O

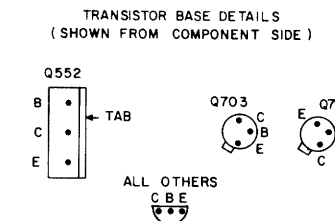

NOTE:  
1. COMPONENTS DESIGNATED WITH ASTERISK (\*) ARE PRESENT ON DUPLEX MODELS (TLD9242A, 41A) ONLY.  
2. COMPONENTS AND JUMPERS DESIGNATED WITH SQUARE (■) ARE PRESENT ON SIMPLEX MODELS (TLD9232A, 31A) ONLY.

### Exciter Range

| Kit No.  | Range    | Frequency (MHz) | Type    |
|----------|----------|-----------------|---------|
| TLD9231A | Low (L)  | 132-150.8       | Simplex |
| TLD9232B | High (H) | 146-174         | Simplex |
| TLD9241B | Low (L)  | 132-150.8       | Duplex  |
| TLD9242C | High (H) | 146-174         | Duplex  |

## parts list

| REFERENCE SYMBOL | MOTOROLA PART NO. | DESCRIPTION                             |
|------------------|-------------------|---|
| C501             | 21-11015B05       | capacitor, fixed: uF ± 5%; 50 V;        |
| C502             | 23-11019A09       | 220 pF ± 10%; 100 V                     |
| C503, 504        | 8-11017B14        | .047                                    |
| C505, 506, 507   | 21-11015B05       | 220 pF ± 10%; 100 V                     |
| C508             | 8-83813H14        | 0.43 uF; 5%; 50 V                       |
| C509             | 8-11017A08        | .01                                     |
| C510             | 8-83813H24        | .036                                    |
| C511             | 8-11017A01        | .001                                    |
| C512             | 21-11015B05       | 220 pF ± 10%; 100 V                     |
| C513             | 21-11021H03       | .01 ± 80-20%; 50 V (TLD9231A, 32B only) |
| C513             | 23-11019A09       | 1 ± 20%; 50 V (TLD9241B, 42C only)      |
| C551, 552, 553   | 21-11015B13       | .001 ± 10%; 100 V                       |
| C554             | 23-11019A46       | 100 ± 20%; 25 V                         |
| C555             | 21-11015B13       | .001 ± 10%; 100 V                       |
| C556             | 23-11019A46       | 100 ± 20%; 25 V                         |
| C557             | 21-11021H03       | .01 ± 80-20%                            |
| C701L            | 21-11022G48       | 56 pF                                   |
| C701H            | or 21-11014H43    | 56 pF; 100 V                            |
| C702L            | 21-11022G44       | 39 pF                                   |
| C702H            | 21-82450B18       | 2 pF; 500 V                             |
| C703L            | 21-82450B13       | 1.5 pF; 500 V                           |
| C703H            | 21-11022G50       | 68 pF                                   |
| C703H            | or 21-11014H45    | 68 pF; 100 V                            |
| C704H            | 21-11022G46       | 47 pF                                   |
| C705             | 21-82450B18       | 2 pF; 500 V                             |
| C706L            | 21-82450B13       | 1.5 pF; 500 V                           |
| C706H            | 21-11022G57       | 120 pF                                  |
| C707             | 21-11022G50       | 68 pF                                   |
| C708             | 21-11015B13       | .001 ± 10%; 100 V                       |
| C709             | 21-82372C09       | 0.1 ± 80-20%; 25 V                      |
| C710             | 21-11022G30       | 10 pF                                   |
| C711             | 21-11015B13       | .001 ± 10%; 100 V                       |
| C712             | 21-11021H03       | .01 ± 80-20%; 50 V                      |
| C713L            | 21-11015B13       | .001 ± 10%; 100 V                       |
| C714L            | 21-11021F04       | .01 uF                                  |
| C715L            | 21-11022G38       | 22 pF                                   |
| C716L            | 21-11022K23       | 16 pF                                   |
| C717L            | 21-82450B13       | 1.5 pF; 500 V                           |
| C718L            | 21-82450B39       | 0.91 pF; 500 V                          |
| C719L            | 21-11022G43       | 36 pF                                   |
| C720L            | 21-11022G40       | 27 pF                                   |
| C721L            | 21-11022G53       | 82 pF                                   |
| C722L            | 21-11014H44       | 62 pF                                   |
| C723L            | 21-11015B13       | .001 ± 10%; 100 V                       |
| C724L            | 21-11015B13       | .001 ± 10%; 100 V                       |
| C725L            | 21-11022G27       | 9 pF; 100 V                             |
| C726L            | 21-82450B19       | 1.8 pF; 500 V                           |
| C727L            | 21-82450B47       | 1 pF; 500 V                             |
| C728L            | 21-11022G33       | 13 pF ± 0.5 pF                          |
| C729L            | 21-11022G30       | 10 pF ± 0.5 pF                          |
| C730L            | 21-11022G34       | 15 pF                                   |
| C731L            | 21-11022G31       | 11 pF                                   |
| C732L            | 21-11015B15       | .0015                                   |
| C733L            | 23-11019A20       | 10 ± 10%; 25 V                          |
| C734L            | 21-82372C10       | .05 ± 20%; 25 V                         |
| C735L            | 21-11015B05       | 220 pF ± 10%; 100 V                     |
| C736L            | 21-11022G38       | 22 pF                                   |
| C737L            | 21-11022G59       | 150 pF                                  |
| C738L            | 21-11021H03       | .01 ± 80-20%; 50 V                      |
| C739L            | 21-82450B46       | 0.82 pF; 500 V                          |
| C740L            | 21-11015B13       | .001 ± 10%; 100 V                       |
| C741L            | 21-11021H03       | .01 ± 80-20%; 50 V                      |
| C742L            | 21-82610C74       | 13 pF; N150                             |
| C743L            | 21-80171A25       | 9.1 pF ± 25 pF                          |
| C744L            | 21-11022G48       | 56 pF                                   |
| C745L            | or 21-11014H43    | 56 pF; 100 V                            |
| C746L            | 21-11022G47       | 51 pF                                   |
| C747L            | 21-11015B05       | 220 pF ± 10%; 100 V                     |
| C748L            | 21-11015B05       | 220 pF ± 10%; 100 V                     |
| C749L            | 20-84579B11       | variable; 7.57 pF                       |
| C750L            | 21-11022G25       | 8 pF ± 0.5 pF                           |
| C751L            | or 21-851846      | 8 pF ± 25 pF                            |
| C752L            | 21-11022G20       | 6 pF ± 0.5 pF                           |
| C753L            | 21-11022G47       | 51 pF                                   |
| C754L            | 21-11022G44       | 39 pF                                   |
| C755L            | 21-11022G25       | 8 pF ± 0.5 pF                           |
| C756L            | or 21-851846      | 8 pF ± 25 pF                            |
| C757L            | 21-11022G20       | 6 pF ± 0.5 pF                           |
| C758L            | 23-84538G06       | 47 ± 20%; 20 V                          |
| C759L            | 21-11021H03       | .01 ± 80-20%                            |
| C760L            | 8-11017B17        | 0.1 ± 10%                               |
| C761L            | 21-11015B13       | .001 ± 10%; 100 V (TLD9242C, 41B only)  |
| C762L            | 23-11019A09       | 1 ± 20%                                 |
| CR552            | 48-83654H02       | silicon                                 |
| CR553            | 48-83654H01       | silicon                                 |
| CR601 thru 604   | 48-83654H01       | silicon                                 |
| CR701            | 48-82466H13       | silicon                                 |

| REFERENCE SYMBOL | MOTOROLA PART NO. | DESCRIPTION   |
|------------------|-------------------|---|
| CR702            | 48-83654H01       | silicon   |
| CR750            | 48-125C31         | silicon   |
| CR751            | 48-82139G01       | germanium   |
| J601 thru 604    | 28-80096A02       | connector, receptacle:<br>male: 5-contact   |
| L502             | 24-80036A02       | coil, rf:<br>choke: 1/2 turn<br>coded: 6-1/2 turns coded (VIO)  |
| L701             | 24-83377G11       | 6-1/2 turns, coded (YEL)  |
| L702, 703        | 24-80068A17       | 4-1/2 turns, coded (WHT)  |
| L704             | 24-80068A18       | 4-1/2 turns, coded (ORG)  |
| L705             | 24-80068A19       | 4-1/2 turns, coded (WHT)  |
| L706             | 24-80034A02       | 3-1/2 turns, coded (WHT)  |
| L707             | 24-80034A03       | 3-1/2 turns, coded (RED)  |
| L708             | 24-80034A01       | 3-1/2 turns, coded (ORG)  |
| L720, 721        | 24-82835G13       | choke: 0.82 uH  |
| L722             | 24-82723H04       | 0.29 uH   |
| L723             | 24-82835G13       | choke: 0.82 uH  |
| L724             | 24-83961B01       | 3-1/2 turns   |
| L750             | 24-82723H27       | choke: 1.2 uH   |
| L751             | 24-82835G13       | choke: 0.82 uH  |
| L752             | 24-84411B03       | 11-1/2 turns, coded (BRN)   |
| L753             | 24-83884G01       | 3-1/2 turns, coded (PINK)   |
| L754             | 24-84411B04       | 10-1/2 turns, coded (ORG)   |
| L755             | 24-83284G07       | 2-1/2 turns, coded (GRN)  |
| L756             | 24-84411B04       | 10-1/2 turns, coded (ORG)   |
| L757             | 24-82835G13       | choke: 0.82 uH  |
| L758             | 24-83961B07       | choke: 2 turns  |
| L759             | 24-83861B01       | choke: 3 turns; (TLD9231A, 32B only)  |
| P500, 501        | 28-83254N01       | connector, plug:<br>male: 10-contact (TLD9241B, 42C only)<br>female: 10-contact (TLD9231A, 32B only)<br>female: phono |
| P700             | 9-82872N01        | female: phono   |
| Q501             | 48-869642         | NPN, type M9642   |
| Q502             | 48-869643         | PNP, type M9643   |
| Q503             | 48-869642         | NPN, type M9642   |
| Q504             | 48-869643         | PNP, type M9643   |
| Q505             | 48-869642         | NPN, type M9642   |
| Q552             | 48-84411L10       | PNP, type M1110   |
| Q553             | 48-869642         | NPN, type M9642   |
| Q554             | 48-869643         | PNP, type M9643   |
| Q701             | 48-869649         | NPN, type M9494   |
| Q702             | 48-869638         | NPN, type M9638   |
| Q703             | 48-869657         | NPN, type M9657   |
| Q704             | 48-869859         | NPN, type M9859   |
| R501             | 6-11009A65        | 4.7k  |
| R502             | 6-11009A57        | 2.2k  |
| R503             | 6-11009A27        | 120   |
| R504             | 6-11009A25        | 100   |
| R505, 506        | 6-11009A83        | 27k   |
| R507, 508        | 6-11009A13        | 33  |
| R509, 510        | 6-11009A93        | 68k   |
| R511             | 6-10621B94        | 1000 precision  |
| R513             | 6-11009A85        | 33k   |
| R514             | 6-11009A73        | 10k   |
| R515             | 6-11009A73        | 10k   |
| R517             | 6-11009A63        | 3.9k  |
| R518, 519        | 6-11021C75        | 6.8k ± 1%   |
| R520             | 6-11009A43        | 560   |
| R521             | 6-11009A83        | 27k   |
| R551, 552        | 6-11009A48        | 910   |
| R554             | 6-11009A59        | 2.7k  |
| R555             | 6-11009A73        | 10k   |
| R701             | 6-11009A65        | 4.7k  |
| R702             | 6-11009A92        | 62k   |
| R703             | 6-11009A49        | 1k  |
| R704             | 6-11009A79        | 18k   |
| R705L            | 6-11009A13        | 33  |
| R705H            | 6-11009A05        | 15  |
| R706L            | 6-11009A81        | 22k   |
| R706H            | 6-11009A83        | 27k   |
| R707             | 6-11009A17        | 47  |
| R708L            | 6-11009A23        | 82  |
| R708H            | 6-11009A25        | 100   |
| R709             | 6-11009A57        | 2.2k  |
| R710             | 6-11009A25        | 100   |
| R711             | 6-11009A57        | 2200  |
| R712             | 6-11009A73        | 10k   |
| R750             | 6-11009A37        | 330   |
| R751             | 6-11009A17        | 47  |
| R752L            | 6-11009A90        | 51k   |
| R752H            | 6-11009A93        | 68k   |
| R753L            | 6-11009A90        | 51k   |
| R753H            | 6-11009A93        | 68k   |

| REFERENCE SYMBOL | MOTOROLA PART NO. | DESCRIPTION                           |
|------------------|-------------------|---------------------------------------|
| R754             | 6-11009A09        | 222                                   |
| R755             | 6-125C31          | 180 ± 10%; 1/2 W                      |
| R756             | 6-11009A57        | 2.2k                                  |
| R756L            | 6-11009A49        | 1k                                    |
| R756H            | 6-11009A57        | 2.2k                                  |
| R757L            | 6-11009E33        | 220                                   |
| RT512            | 6-84259H02        | thermistor:<br>44k ± 10% -25°C        |
| mechanical parts |                   |                                       |
|                  | 3-84256M01        | SCREW, tapping; 2 used                |
|                  | 5-84220B01        | GROMMET; 2 used                       |
|                  | 6-11009B23        | JUMPERS; 15 used (TLD9231A, 32B only) |
|                  | 14-861196         | INSULATOR; 2 used                     |
|                  | 26-80039A01       | CAN. coil; 3 used                     |
|                  | 26-80150B01       | HEAT SINK Q704                        |
|                  | 26-80196A01       | CAN. coil; 5 used                     |
|                  | 25-83283N01       | SHIELD, exciter top                   |
|                  | 26-83284N01       | SHIELD, exciter bottom                |
|                  | 42-82160N01       | CLIP, shield mounting; 3 used         |
|                  | 45-83824N01       | EJECTOR, card; 2 used                 |
|                  | 5-84220B01        | GROMMET; 2 used                       |
|                  | 42-82160N01       | CLIP, shield mounting; 3 used         |

note: For optimum performance, diodes, transistors, and integrated circuits must be ordered by Motorola part numbers.

EXCITER

SCHEMATIC DIAGRAM

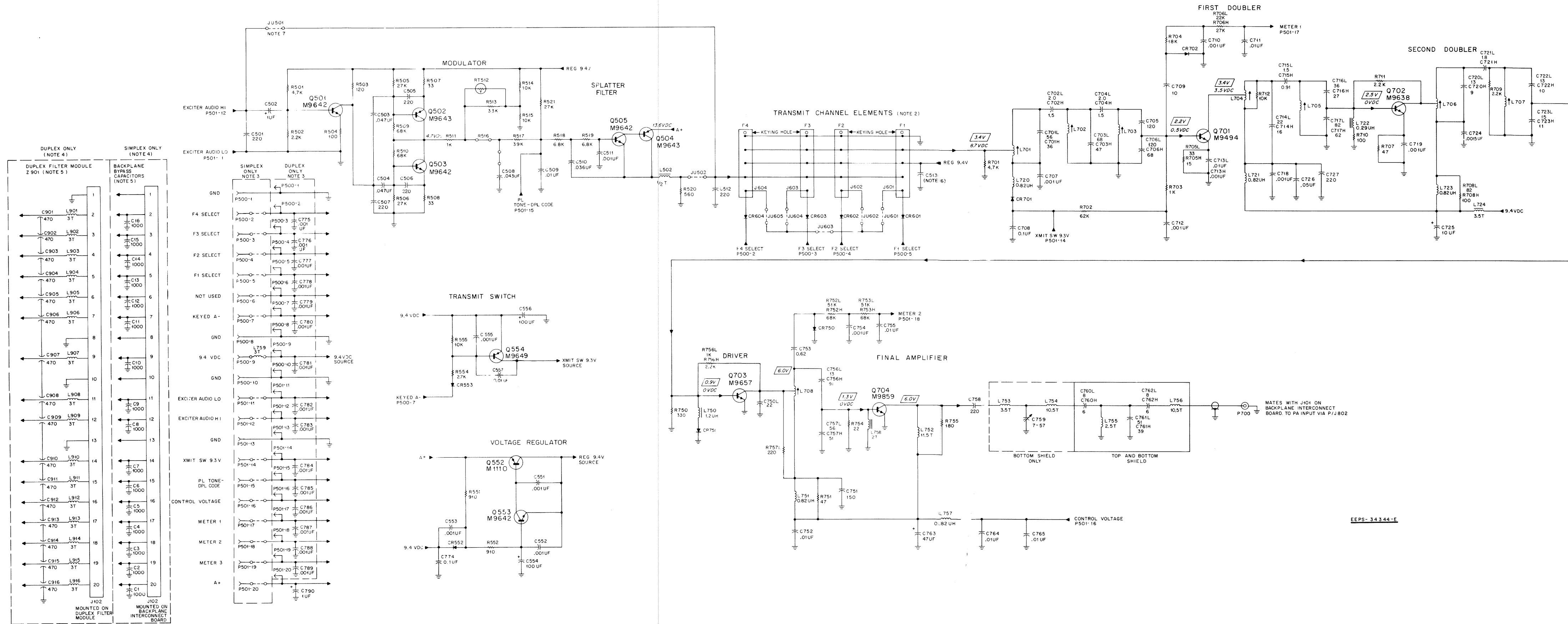

- NOTES:
- Unless otherwise indicated: resistor values are in ohms and capacitor values are in picofarads.
  - Transmitter frequency calculation:  
 $F_{oscillator} = F_{channel}/12$
  - TLD9231A/TLD9232B Simplex Exciter uses jumpers shown, with female edge connectors P500/P501. TLD9241B/TLD9242C Duplex Exciter uses C775-C789 shown, with male edge connectors P500/P501.
  - Simplex exciter is connected to male backplane connector J102. Duplex exciter is connected to female filter module connector J102.
  - Backplane bypass capacitors C1-C16 and duplex filter module are part of backplane interconnect board assembly. Refer to associated Control and Applications manual for replacement parts information and location.
  - Refer to parts list for component values.
  - JU501 always out on standard models.

*Exciter Range*

| Kit No.  | Range    | Frequency (MHz) | Type    |
|----------|----------|-----------------|---------|
| TLD9231A | Low (L)  | 132-150.8       | Simplex |
| TLD9232B | High (H) | 146-174         | Simplex |
| TLD9241B | Low (L)  | 132-150.8       | Duplex  |
| TLD9242C | High (H) | 146-174         | Duplex  |

EEPS-34344-E



## 1. GENERAL

The TLD2532A Power Amplifier consists of the power amplifier chassis and associated hardware, and contains two circuit boards, the power control board and the power amplifier board. The following sections detail the theory of operation and troubleshooting information for the power amplifier circuitry. Because the setting of power levels is affected by the alignment of the exciter, the power set procedure is part of the overall transmitter alignment procedure given in the Transmitter section of this manual.

*Table 1. Power Amplifier Kits*

| TLD2532A Power Amplifier                |
|---|
| TFD6452A Harmonic Filter                |
| TKN8313A Power Amplifier Cable          |
| TLD9252A Power Amplifier Board          |
| TLD9272A Power Control Board            |
| TRN5141A Power Amplifier Hardware Kit   |
| TRN5378A PA Transistor and Hardware Kit |

## 2. THEORY OF OPERATION

### 2.1 POWER AMPLIFIER BOARD

**2.1.1** The output from the exciter is applied to the power amplifier board via J802. This 1.5 watt (nominal) signal is attenuated approximately 2.8 dB by the resistive network comprised of R807-R810. Predriver Q801 amplifies the exciter signal to a level of approximately 11 watts.

**2.1.2** The predriver output is applied to driver Q802, which develops up to 25 watts of rf power. The final amplifier stage of Q803/Q804 provides the power output of 110 watts (nominal). The power output signal is routed through the harmonic filter and through the directional coupler to the station antenna circuitry.

### 2.2 POWER CONTROL CIRCUITRY

#### 2.2.1 General

**2.2.1.1** The power control board provides power amplifier protection and power regulation. Output impe-

dance match, final amplifier current and temperature, control voltage level, and power output are monitored by the power control circuit. In turn, the power control circuit sets the exciter power output to the proper level for optimum power amplifier operation.

**2.2.1.2** The resistive voltage divider comprised of R926, R927, and R928 provides dc biasing voltages to improve directivity of the directional coupler, and set the operating point of the directional coupler inputs to the forward power and protection comparators. The reference voltage for forward power detector U901A is developed across Power Set control R911. The reference voltage for protection comparator U901B is developed at the junction of R914 and R913.

#### 2.2.2 Thermal Protection

As the temperature of the power amplifier board increases, the resistance of RT801 decreases, causing the voltage on the TEMP SENSE HI line to decrease. When this voltage reaches approximately 5 volts, CR904 conducts, dropping both the forward power detector and protection comparator reference voltages. This causes the comparators to reduce the voltage on the CONTROL VOLTAGE line, which reduces exciter drive to the power amplifier. The net effect of this is to lower power amplifier output and heat, keeping operating temperature within safe operating limits.

#### 2.2.3 Forward Power Level Control

Forward output power, sampled by the directional coupler, is rectified and filtered by the circuitry associated with CR901. The detected voltage is applied to the inverting input of forward power detector U901A, where it is compared to the set level at the non-inverting input. If the two levels are not the same, the output level of U901A changes in a direction that raises or lowers the voltage on the CONTROL VOLTAGE line, until the inputs to U901A are matched. This provides a constant rf power output from the PA.

## 2.2.4 Reverse Power Protection

Reverse (reflected) power sampled by the directional coupler is rectified and filtered by the circuitry associated with CR902. The output voltage across R908 is applied to the inverting input of U901B, and compared to the reference voltage. Under normal operating conditions with the transmitter feeding a 50-ohm load, the reference voltage is higher than the directional coupler voltage. This keeps the output of U901B at maximum, keeping Q905 turned off. If the reflected power increases to the point that the voltage across R908 exceeds the reference voltage, the output of U901B drops, turning on Q905. Increased collector voltage on Q905 causes an increase in the voltage applied to the inverting input of U901A, to force the control voltage and the power output to drop until the inputs to U901A equalize.

## 2.2.5 Over-Current Protection

Final amplifier current in the power amplifier is sensed through R801. The voltage drop across R801 is applied to the base at Q907. As the voltage at Q907 decreases, Q907 turns on, increasing the voltage across R908. The power cutback occurs in the same manner as described in the Reverse Power Protection paragraph.

## 2.2.6 Control Voltage Limit

The circuit of Q905 compares the voltage on the CONTROL VOLTAGE line to the voltage set by the position of the wiper on R931. When the control voltage exceeds the set limit, Q905 conducts, raising the voltage at the inverting input of U901A. U901A, in turn, reduces the control voltage until both inputs are balanced.

# 3. POWER AMPLIFIER SERVICING

## 3.1 GENERAL

Troubleshooting information for the *MSR 2000* station power amplifier is presented in several levels. It is best to begin by following the power amplifier troubleshooting procedure given in Table 4. If the specific cause of the transmitter failure is not covered in Table 4, the service person is directed to Table 5 (for power control board problems) or to paragraph 3.2 (for power amplifier board problems).

## 3.2 POWER AMPLIFIER BOARD TROUBLESHOOTING PROCEDURE

Checks and tests in the following paragraphs may be used to locate defects isolated to the power amplifier board. The following checks assume 13.8 volts dc is applied to the PA and that the amplifier is operating closed-loop with the exciter. Set all power control potentiometers (R911, R931, R939) fully clockwise.

## 3.2.1 No Power Output or Power Output Less Than 20% of Rated Power

### 3.2.1.1 VOLTAGE CHECKS

With the radio unkeyed and the receiver audio at a minimum, check for +13.3 V dc on the power amplifier collectors. If one or more stages has zero voltage, check associated dc feed circuits for an open circuit.

### 3.2.1.2 INDIVIDUAL STAGE CURRENT CHECKS

Check the collector currents drawn by all stages to determine if the normal value shown in Table 2 is drawn.

Table 2. Minimum Normal Current Reading (all power control potentiometers set fully clockwise)

|        | I <sub>c</sub>   | 146-155 MHz | 155-165 MHz | 165-174 MHz |
|--------|------------------|-------------|-------------|-------------|
| Q801   | Direct           | 1.7A        | 1.2A        | 0.75A       |
| Q802   | Direct           | 3.0A        | 2.4A        | 2.1A        |
|        | Drop across R822 | 300 mV      | 240 mV      | 210 mV      |
| Q803-4 | Direct           | 20A         | 17A         | 18A         |
|        | Drop across R801 | 20 mV       | 170 mV      | 180 mV      |
|        | MTR 5            | 20 uA       | 17 uA       | 18 uA       |

Step 1. If a stage is found with less than minimum I<sub>c</sub> (see Table 2), check for shorts or defective components in that stage, then in the preceding and following stages.

Step 2. Where more than one stage indicates low current, check the earliest defective stage (toward the PA input) first.

Step 3. If all stages give a low current indication, check the exciter output. The exciter is defective if the output is less than 1.5 W.

## 3.2.2 Power Output Does Not Exceed the Rated Radio Power by 20% at Maximum Power Settings

3.2.2.1 Check A+ and A- voltages at the collectors with the power amplifier operating. Use *only* a passive voltmeter or a VOM with 1.2 uH series chokes at the probe tips. With the power supply accurately set for 13.8 V dc, voltages on the transistor collectors should exceed the Table 3 values (all voltages measured with respect to the A- plating on the power amplifier board).

Step 1. If all voltages are low, recheck the power supply. If the power supply is satisfactory, check the feed-through capacitors for poor solder connections and the A+ and A- connections for good contact.

Step 2. If only one or two stages have low voltages, trace back through the dc-feeds of that stage, checking for bad connections or defective components. The maximum normal voltage drops are 0.3 V dc for R801, 0.5 V

dc for R822, and less than 0.1 V dc for all other components in the dc feed circuits.

Table 3. PA Collector Voltages (@13.8 V A + /A- Supply)

|           |           |
|-----------|-----------|
| Q801      | 13.0 V dc |
| Q802      | 12.6 V dc |
| Q803, 804 | 12.8 V dc |

3.2.2.2 Check the stage currents as outlined in paragraph 3.2.1.2.

3.2.2.3 If trouble in the final amplifier transistor stage (Q803, 804) is indicated, or other approaches have failed, check the balance in the final amplifier by soldering a 2.7 V lamp (type 338, Motorola Part No. 65-82671G01) between the collectors of Q803 and Q804 using #14 wire or a 0.1 inch wide copper strap or braid. If the lamp lights up to greater than half its normal brilliance, or flashes and burns out, there is a defect in one side of the parallel final amplifier circuitry. If such imbalance is indicated, the defective section can usually be isolated by shorting the base to emitter of one transistor (at the transistor body) with a screwdriver blade. The section that shows the least drop in power output (when shorted) is the one to be checked for defective components. If no obviously defective passive components, misconnections, or shorts can be located, make the following tests prior to considering the replacement of Q803 or Q804.

#### NOTE

Remove all power from the PA for the following tests.

Step 1. Check in-circuit base-emitter resistance on the suspect transistor(s). If *greater* than 1 ohm, coil L809 or L810 is bad.

#### NOTE

Place the negative potential lead from the ohmmeter on the transistor base for this test.

Step 2. If the resistance check shows that L809 and L810 are not defective, remove the base capacitors, C825 and C827 (for Q803) or C826 and C828 (for Q804), and check for shorts, both internal (with an ohmmeter), and external (visual check for solder shorts on the capacitor or printed circuit board). If a capacitor or its connection is suspect, replace it and recheck the power output and balance before proceeding.

Step 3. If the capacitor is not defective, replace transistor (Q803 or Q804) and reassemble the power amplifier.

#### NOTE

In any case where gross imbalance is found and suspected faulty components are replaced, *always* recheck balance after replacing components. Continue the investigation if imbalance has not been fully corrected.

3.2.2.4 With all power removed from the radio set, check for open base return on Q801 and Q802 by measuring in-circuit base-emitter resistance. The resistance should be less than 1 ohm on Q801 and less than 2.5 ohms on Q802.

#### NOTE

Place negative potential lead of ohmmeter on transistor base(s) for this test.

### 3.3 POWER AMPLIFIER TRANSISTOR REPLACEMENT

3.3.1 To remove the power transistors, remove two transistor mounting screws, or one stud nut (accessible from the chassis bottom). Unsolder and remove the clamped mica capacitors, unsolder and remove the transistors. (Special soldering iron tips ST1160 and ST1161 are available from the Motorola National Parts Department to aid in the capacitor and transistor removal.)

3.3.2 When replacing rf power transistors several precautions *must* be observed. First remove all thermal compound and residue from *both the chassis and the transistor* using a soft cloth or paper towel. Apply a thin film of silicone thermal compound to the bottom of the transistor mounting flange. Place the transistor in the center of the printed circuit board cutout and tighten the mounting hardware to 6-7 inch pounds *maximum*. Solder leads using a low power (40-60 W) iron using enough solder to completely cover the lead and solder pad. *Make sure* that the solder is flowing freely both *over* and *under* the lead before removing the heat. If a lead tends to spring away from the printed circuit board, hold down the far end of the lead against the board (using the tip of pliers) until the solder hardens. *Be sure* to replace the clamped mica capacitors in the *exact* original position with respect to the transistor body after replacing the transistors.

3.3.3 When removing components from the power amplifier printed circuit board it is *essential* that the solder be *completely molten* around the lead(s) to be removed *before* attempting to remove any component(s). Failure to exercise this precaution *could result* in removal of through-plating in component holes and/or top side metal on the printed circuit board which may necessitate removal of the printed circuit board for repair. To ensure proper performance of the rf power amplifier, it is *essential* (when replacing board-mounted parts) that the parts be mounted vertically and with the

bottom of the component(s) flush against the printed circuit board.

### 3.4 POWER AMPLIFIER BOARD REMOVAL

**3.4.1** Under normal maintenance conditions, there should be no need to remove the PA board. If, however, it should become necessary, the following procedure should be used. Unsolder and remove the input and output coaxial cables, unsolder feedthrough capacitors, remove hex head screws, transistor mounting screws, and stud nut(s) (accessible from the bottom). Lift the board out of the chassis.

**3.4.2** To replace the PA board, reverse the removal procedure. PA power transistors should be installed after the circuit board installation has been completed. Refer to paragraph 3.3.

### 3.5 POWER AMPLIFIER FUNCTIONAL TESTS

#### 3.5.1 General

The tests in this section should be performed *after* servicing but *before* alignment, to verify that the power amplifier and control circuitry are operating correctly.

#### 3.5.2 Set-Up

Step 1. Connect radio to proper dummy load through a wattmeter.

Step 2. Plug metering connector of DC Metering Chassis, TEK 5 Metering Panel (set to position E) or S1056-59 Portable Test Set, into J1 on power control board.

#### **CAUTION**

Key transmitter only while making test or adjustment.

#### 3.5.3 Control and Protection Tests

##### 3.5.3.1 CONTROL VOLTAGE LIMITING

Step 1. Set Current Limit (R939) and Power Set (R911) fully clockwise.

Step 2. Set Control Voltage Limit (R931) fully counterclockwise. Key transmitter and observe meter 1. Meter 1 should read approximately 4 uA.

Step 3. Rotate Control Voltage Limit Set (R931) clockwise. Near mid-rotation the reading of M1 should begin increasing to a maximum of approximately 25 uA at maximum clockwise rotation.

##### 3.5.3.2 CURRENT LIMITING

Step 1. Set Power Set (R911) and Control Voltage Limit (R931) fully clockwise.

*Table 4. Power Amplifier Troubleshooting Procedure*

| Step | Symptom                       | Procedure   | Normal Indication          | If Normal  | If Abnormal  |
|------|-------------------------------|---|----------------------------|--|--|
| 1    | Suspected Transmitter Failure | Measure rf output power at antenna connector.                             | Rated power                | Transmitter OK.  | High Power — perform Power Amplifier Control and Protection Troubleshooting Procedure.<br>Low Power — go to 3.<br>No Power — go to 2.      |
| 2    | No Output Power               | a. Set all controls fully clockwise and observe meters 1 and 5.           | Both greater than 10 uA    | Go to b.   | No indication — Perform Transmitter Control and Protection Troubleshooting Procedure. Meter 1 indication, no Meter 5 indication — Go to e. |
|      |                               | b. Measure dc voltage across antenna relay coil during transmit.          | 5 V                        | Go to c.   | Check coil continuity (dc resistance approximately 160 ohms).  |
|      |                               | c. Check reed switch continuity.  | Continuous during transmit | Go to d.   | Replace.   |
|      |                               | d. Check harmonic filter and output cable for shorts and discontinuities. | See schematic diagram      | Perform Power Amplifier Board Troubleshooting Procedure. | Repair defect.   |
|      |                               | e. Measure rf power at the exciter output.                                | 1.5 W minimum              | Perform Power Amplifier Board Troubleshooting Procedure. | Refer to Exciter section of manual.  |
| 3    | Low Output Power              | a. Set all controls fully clockwise and observe Meter 1.                  | Greater than 20 uA         | Go to b.   | Perform Power Amplifier Control and Protection Troubleshooting Procedure.  |
|      |                               | b. Measure rf power at exciter output.                                    | 1.5 W minimum              | Perform Power Amplifier Board Troubleshooting Procedure. | Refer to Exciter section of manual   |

Table 5. Power Amplifier Control and Protection Troubleshooting Procedure

| Step | Symptom   | Procedure  | Normal Indication        | If Normal   | If Abnormal  |
|------|---|--|--------------------------|---|--|
| 1    | No meter 1 or 5 with all controls clockwise   | a. Disconnect PA from exciter J802. Check for keyed 9.3 V at U901-8.                                 | 9.3 V                    | Go to b.  | Check Q554 (in exciter) keyed 9.3 V switch.                                |
|      |   | b. Measure output voltage of U901A, pin 1.   | Greater than 3.3 V       | Repair fault in control voltage amplifiers Q903 & Q904. | Go to c.   |
|      |   | c. Measure voltages to input of U901A, pins 2 & 3.   | Pin 3 greater than Pin 2 | U901 defective.   | Check for shorts or opens in resistive feed circuits to pins 2 & 3.        |
| 2    | Meter 1 reads max of about 10 uA with all controls fully clockwise. Little or no output power | a. Disconnect PA from exciter at J802. Measure voltage of protection comparator output, at U901B-7.  | Greater than 7 V         | Troubleshoot Q905 circuit.                              | Go to b.   |
|      |   | b. Measure voltages to input of U901B, pins 5 & 6.   | Pin 5 greater than Pin 6 | U901 defective.   | Analyze and repair current limiter circuitry Q906, Q907 & Q908.            |
| 3    | All controls inoperative and meter 1 approx. 25 uA  | a. Disconnect PA from exciter at J802. Observe meter 1 in RX mode.                                   | 0 uA                     | Go to b.  | Repair fault in control voltage amplifiers Q903 & Q904.                    |
|      |   | b. Set all controls counterclockwise. Measure pins 2 & 3, U901A in TX mode.                          | Pin 2 greater than Pin 3 | U901 defective  | Look for defect in voltage reference network R926, U927, R928, R912, R911. |
| 4    | Q905 and associated resistors probably defective. Analyze and repair.                         | Control voltage limit (R931), current limit (R939) and reflected power (VSWR) protection inoperative |                          |   |  |
| 5    | Current limit (R939) inoperative  | Disconnect PA from exciter at J802. Pull current sense line (green) from C897. Observe meter 1.      | 15 uA                    | Check for short to A+ of current sense line.            | Analyze fault in current limit circuit Q906, Q907 & Q908 and repair.       |
| 6    | Reflected power (VSWR) protection inoperative   | Check and repair defect in reflected power detector components R902, CR902, etc.                     |                          |   |  |
| 7    | Thermal protection inoperative  | Check and repair defect in thermal protection components RT801, R915, R930 and CR904.                |                          |   |  |
| 8    | Power set (R911) inoperative  | Check and repair defect in forward power detector components R901, CR901, etc.                       |                          |   |  |

Step 2. Set Current Limit (R939) fully counterclockwise. Key transmitter and observe M5. Meter 5 should indicate less than 10 uA. Rotate Current Limit clockwise. Meter 5 should increase to a maximum indication of no more than 28 uA before maximum clockwise rotation is reached.

### 3.5.3.3 POWER SET

Step 1. Set Control Voltage Limit (R931) and Current Limit (R939) fully clockwise.

Step 2. Set Power Set (R911) fully counterclockwise.

Step 3. Key transmitter and observe wattmeter. Power output should be zero. Power output should increase as Power Set is rotated clockwise.

### 3.5.3.4 THERMAL PROTECTION

Step 1. Set Control Voltage Limit (R931) and Current Limit (R934) fully clockwise.

Step 2. Adjust Power Set (R911) to 120 watts output. Using a short length (6 inches), of 22 AWG solid wire, short Temp Sense Hi, pin 6 of P901, to Temp Sense Lo, pin 7 of P901, with P901 connected to J901 on the

power control board. Power output should drop to less than 50% of set power.

### 3.5.3.5 REFLECTED POWER PROTECTION

Step 1. Set Control Voltage Limit (R931) and Current Limit (R939) fully clockwise.

Step 2. Adjust Power Set (R911) for 120 watts output. Remove cable from the output of the station.

---

#### CAUTION

As the following step requires transmitting without a dummy load, key transmitter long enough to verify operation only.

---

Step 3. Key transmitter and observe meter 5. Meter 5 should indicate less than 10 uA.

### 3.5.4 Power Amplifier Board Test

Step 1. Disconnect PA from antenna switch/duplexer at J803.

Step 2. Connect the PA directly to a wattmeter and dummy load via J803.

Step 3. Set Power Set (R911), Control Voltage Limit (R931), and Current Limit (R939) fully clockwise.

Step 4. Key transmitter and observe the wattmeter. Power output should exceed 145 watts.



POWER CONTROL BOARD

SCHEMATIC DIAGRAM & CIRCUIT BOARD DETAIL

POWER CONTROL BOARD

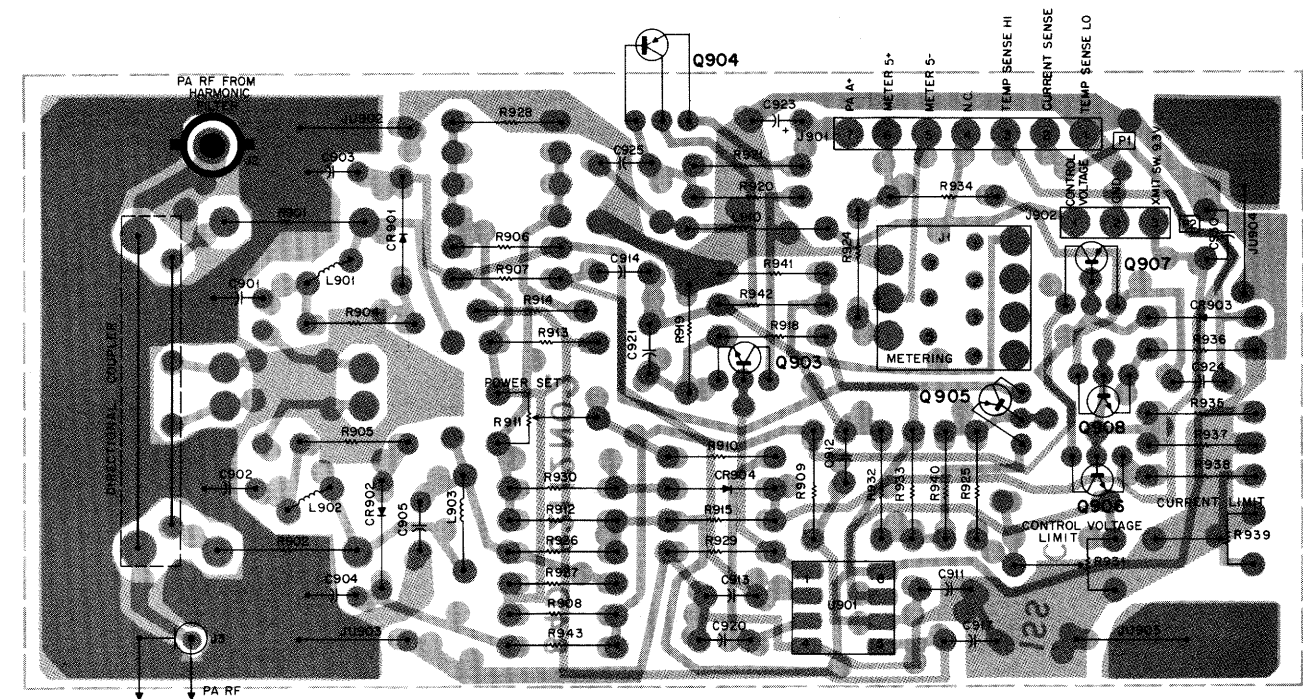

SHOWN FROM COMPONENT SIDE

COMPONENT SIDE = BD DEPS-34661-A  
 SOLDER SIDE = BD DEPS-34662-A  
 OL DEPS-34663-A

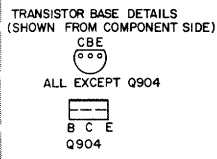

TRANSISTOR BASE DETAILS (SHOWN FROM COMPONENT SIDE)  
 ALL EXCEPT Q904

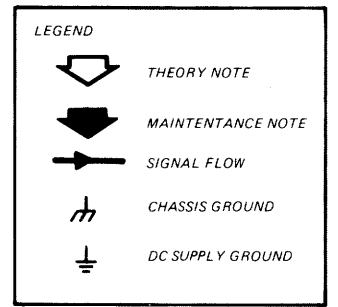
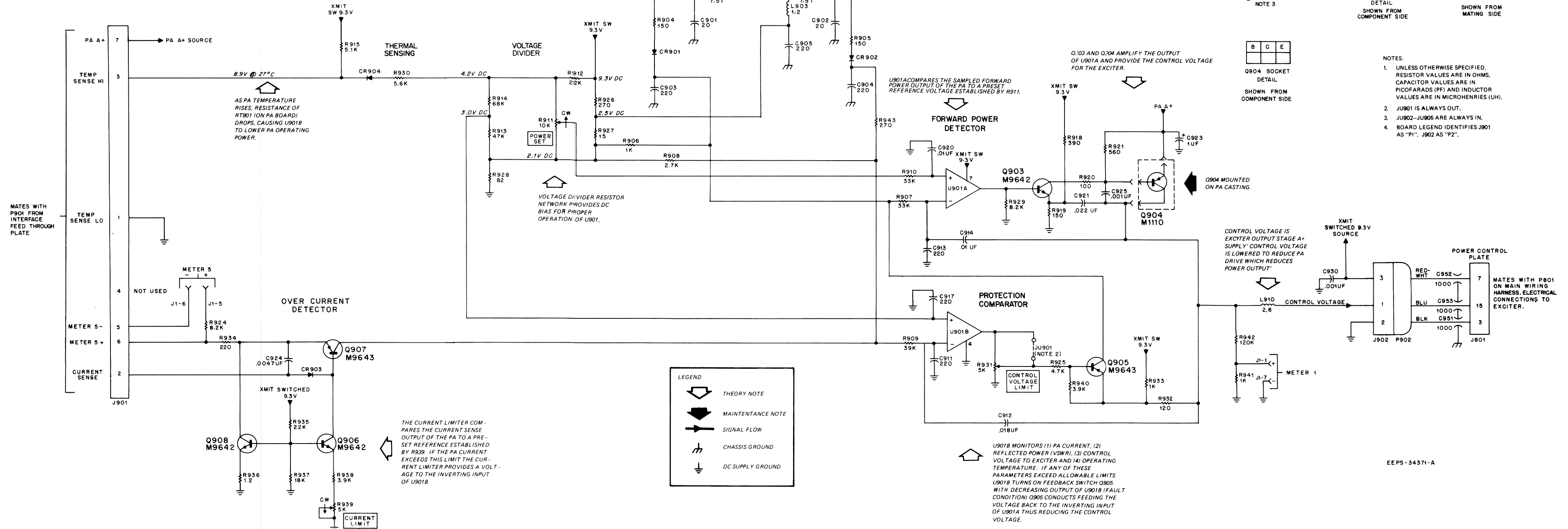

U901B MONITORS (1) PA CURRENT, (2) REFLECTED POWER (VSWR), (3) CONTROL VOLTAGE TO EXCITER AND (4) OPERATING TEMPERATURE. IF ANY OF THESE PARAMETERS EXCEED ALLOWABLE LIMITS U901B TURNS ON FEEDBACK SWITCH Q905 WITH DECREASING OUTPUT OF U901B (FAULT CONDITION) Q905 CONDUCTS FEEDING THE VOLTAGE BACK TO THE INVERTING INPUT OF U901A THUS REDUCING THE CONTROL VOLTAGE.

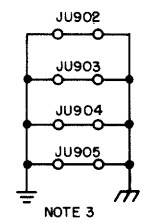

NOTE 3

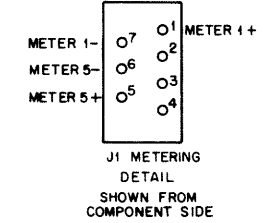

J1 METERING DETAIL SHOWN FROM COMPONENT SIDE

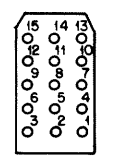

P801 DETAIL SHOWN FROM MATING SIDE

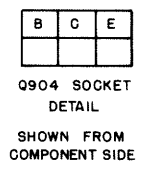

Q904 SOCKET DETAIL SHOWN FROM COMPONENT SIDE

- NOTES:
- UNLESS OTHERWISE SPECIFIED, RESISTOR VALUES ARE IN OHMS, CAPACITOR VALUES ARE IN PICOFARADS (PF) AND INDUCTOR VALUES ARE IN MICROHENRIES (UH).
  - J901 IS ALWAYS OUT.
  - J902-J905 ARE ALWAYS IN.
  - BOARD LEGEND IDENTIFIES J901 AS "P1", J902 AS "P2".

# CIRCUIT BOARD DETAIL AND PARTS LISTS

## POWER AMPLIFIER BOARD

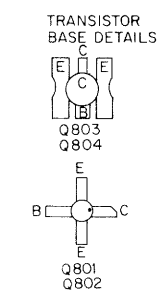
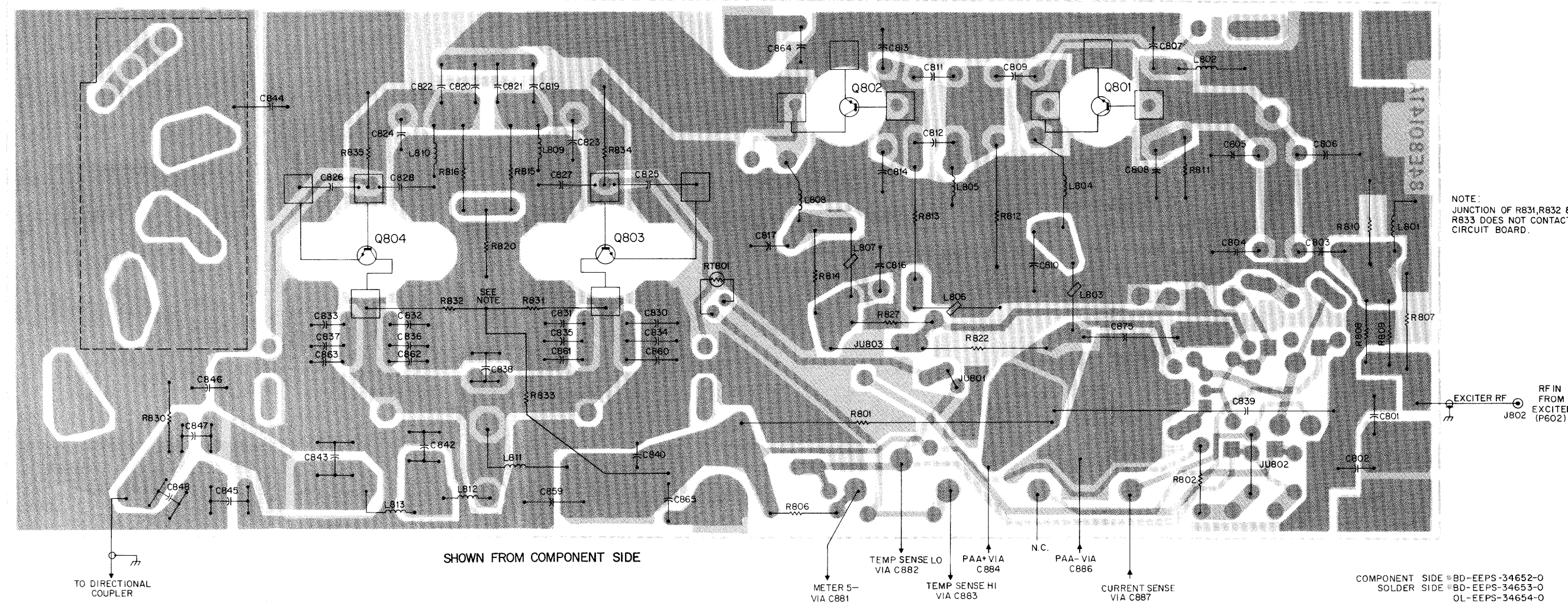

### parts list

TL09252A Power Amplifier Board PL-7938-B

| REFERENCE SYMBOL        | MOTOROLA PART NO. | DESCRIPTION   |
|-------------------------|-------------------|---|
| C801                    | 21-863629         | capacitor, fixed: pF ± 5%; 500 V; unless otherwise stated |
| C802                    | 21-82372C10       | 05 uF ± 20%; 25 V   |
| C803                    | 21-83406D77       | 30  |
| C804                    | 21-84493B59       | 39  |
| C805, 806               | 21-83406D77       | 30  |
| C807, 808               | 21-84493B65       | 100   |
| C809                    | 21-84493B66       | 150   |
| C810                    | 21-83596E10       | 220 ± 20%   |
| C811, 812               | 21-84715F26       | 56  |
| C813, 814               | 21-84493B64       | 91  |
| C816                    | 8-84637L14        | 0.1 uF ± 10%; 100 V                                       |
| C817                    | 21-83596E10       | 220 ± 20%   |
| C819                    | 21-83406D56       | 24  |
| C820, 821               | 21-84493B35       | 19  |
| C822                    | 21-83406D56       | 24  |
| C823, 824               | 21-84715F26       | 56  |
| C830 thru 837           | 21-84715F26       | 56  |
| C838                    | 21-83366K16       | 150   |
| C839                    | 23-83210A22       | 960 uF ± 150-10%; 25 V                                    |
| C840                    | 21-863629         | 330 ± 10%; 600 V  |
| C842                    | 21-84395B18       | 44; 250 V   |
| C843                    | 21-84395B16       | 15 ± 10%; 250 V   |
| C844                    | 21-84493B59       | 39  |
| C845                    | 21-84395B35       | 240 ± 10%; 350 V  |
| C846                    | 21-863629         | 330 ± 10%; 600 V  |
| C847                    | 21-84395B35       | 240 ± 10%; 350 V  |
| C848                    | 21-84395B45       | 12 ± 10%; 250 V   |
| C859                    | 8-83293B02        | 0.22 uF ± 10%; 50 V                                       |
| C860 thru 863           | 21-83406D97       | 15  |
| C864                    | 21-82187B07       | 470 ± 10%   |
| C865                    | 21-83596E10       | 220 ± 20%   |
| C875                    | 8-82905G02        | 0.22 uF ± 10%; 50 V                                       |
| L801                    | 24-83884G01       | coil, rf; 3-1/2 turns; coded (PINK)                       |
| L802                    | 24-8273H27        | choke; 1.2 uH   |
| L803                    | 24-80036A02       | choke; 1/2 turn   |
| L804                    | 24-80277A10       | 12-1/2 turns  |
| L805                    | 7-80062B02        | bracket, large 1/2 turn                                   |
| L806, 807               | 24-80036A02       | choke; 1/2 turn   |
| L808                    | 24-80277A14       | 1-1/2 turns   |
| L809, 810               | 24-8273H27        | choke; 1.2 uH   |
| L811                    | 24-80277A13       | 7-1/2 turns   |
| L812, 813               | 7-80062B04        | bracket, small; 1/2 turn                                  |
| R801                    | 17-80165C01       | resistor, fixed: ± 5%; 1/2 W; unless otherwise stated     |
| R802                    | 6-11009A49        | .01 ± 20% bracket type                                    |
| R806                    | 6-11009C33        | 220; 1/4 W  |
| R807                    | 6-125A37          | 330   |
| R808, 809               | 6-11009C13        | 33; 1/4 W   |
| R810                    | 6-125A37          | 330   |
| R811                    | 6-125C01          | 10 ± 10%  |
| R812                    | 6-127C17          | 47 ± 10%; 2 W   |
| R813                    | 17-82036G07       | 1.5 ± 10%; 2 W  |
| R814                    | 6-125B61          | 4.7   |
| R815, 816               | 6-125A09          | 22  |
| R820                    | 6-125A15          | 39  |
| R822                    | 17-82291B24       | 0.1 ± 5%; 3 W   |
| R830                    | 6-11009C97        | 100k; 1/4 W   |
| R834, 835               | 6-125A21          | 68  |
| RT801                   | 6-83600K09        | thermistor; 100k ± 25°C                                   |
| <b>mechanical parts</b> |                   |   |
| 29-80014A01             |                   | CLIP, coax terminal                                       |

TFD6452A PA Harmonic Filter PL-7935-O

| REFERENCE SYMBOL        | MOTOROLA PART NO. | DESCRIPTION                                 |
|-------------------------|-------------------|---|
| C1                      | 21-83366K33       | capacitor, fixed: 15 pF ± 5%; 850 V         |
| C3, 5                   | 21-82785H52       | 30 pF ± 1 pF; 850 V                         |
| C7                      | 21-83366K33       | 15 pF ± 5%; 850 V                           |
| L2                      | 24-80066A04       | coil, rf; 5-1/2 turns                       |
| L4                      | 24-80066A03       | 6-1/2 turns                                 |
| L6                      | 24-80066A04       | 5-1/2 turns                                 |
| P2                      | 28-82231G01       | connector, plug; male; single contact       |
| <b>mechanical parts</b> |                   |   |
| 1-80748D72              |                   | ASSEMBLY, cable input includes: LUG, solder |
| 29-5370                 |                   | LUG, solder                                 |
| 30-83794C01             |                   | CABLE, coaxial (WHT); 8" used               |
| 1-80748D73              |                   | ASSEMBLY, cable output includes: EYELET     |
| 5-136977                |                   | CABLE, coaxial (WHT); 8-1/2 used            |
| 30-83794C01             |                   | FRAME                                       |

TL09272A Power Control Board PL-7940-A

| REFERENCE SYMBOL        | MOTOROLA PART NO. | DESCRIPTION   |
|-------------------------|-------------------|---|
| C901                    | 21-11022G37       | capacitor, fixed: pF ± 10%; 50 V; unless otherwise stated |
| C902                    | 21-11022G37       | 20 ± 5%   |
| C903, 904, 905          | 21-11015B05       | 220   |
| C911                    | 21-11015B05       | 220   |
| C912                    | 8-11017B10        | .018 uF   |
| C913                    | 21-11015B05       | 220   |
| C914                    | 8-11017B08        | .01 uF  |
| C917                    | 21-11015B05       | 220   |
| C920                    | 21-11021F04       | .01 uF  |
| C921                    | 8-11017B11        | .022 uF   |
| C923                    | 23-11019A09       | 1 uF ± 20%; 50 V  |
| C924                    | 21-11021E21       | 4700  |
| C925                    | 21-11015B13       | .001 uF ± 10%; 100 V                                      |
| C930                    | 21-11015B13       | .001 uF ± 10%; 100 V                                      |
| CR901, 902              | 48-84616A01       | diode; (see note)   |
| CR903, 904              | 48-83654H01       | hot carrier silicon                                       |
| J1                      | 9-84207B01        | connector, receptacle; female; 7-contact (metering)       |
| J2                      | 8-84231B03        | female; phono   |
| J3                      | 42-80259A01       | clip, coax terminal                                       |
| J901                    | 28-83441F08       | connector, plug; male; 7-contact (WHT)                    |
| J902                    | 28-83441F18       | male; 3-contact (WHT)                                     |
| JU902 thru 905          | 6-11009B23        | jumper; 0 ohms  |
| L901, 902               | 24-84393B04       | coil, rf; 7-1/2 turns                                     |
| L903                    | 24-82723H01       | choke; 1.2 uH   |
| L910                    | 24-82935G08       | choke; 2.6 uH   |
| Q903                    | 48-869642         | transistor; (see note)                                    |
| Q906                    | 48-869642         | NPN; type M9642   |
| Q907                    | 48-869642         | PNP; type M9643   |
| Q908                    | 48-869642         | NPN; type M9642   |
| R901, 902               | 6-125A21          | resistor, fixed ± 5%; 1/4 W; unless otherwise stated      |
| R904, 905               | 6-11009A29        | 150   |
| R906                    | 6-11009A49        | 1k  |
| R907                    | 6-11009A85        | 33k   |
| R908                    | 6-11009A59        | 2.7k  |
| R909                    | 6-11009A87        | 39k   |
| R910                    | 6-11009A85        | 33k   |
| R911                    | 18-82374N12       | variable; 10k   |
| R912                    | 6-11009A81        | 22k   |
| R913                    | 6-11009A89        | 47k   |
| R914                    | 6-11009A93        | 68k   |
| R915                    | 6-11009A66        | 5.1k  |
| R916                    | 6-11009A39        | 390   |
| R919                    | 6-11009A29        | 150   |
| R920                    | 6-11009A25        | 100   |
| R921                    | 6-11009A43        | 560   |
| R924                    | 6-11009A71        | 8.2k  |
| R925                    | 6-11009A65        | 4.7k  |
| R926                    | 6-11009A35        | 270   |
| R927                    | 6-11009A05        | 150   |
| R928                    | 6-11009A23        | 82  |
| R929                    | 6-11009A71        | 8.2k  |
| R930                    | 6-11009A97        | 5.6k  |
| R931                    | 18-82374N13       | variable; 5k  |
| R932                    | 6-11009A27        | 120   |
| R933                    | 6-11009A49        | 1k  |
| R934                    | 6-11009A33        | 220   |
| R935                    | 43-82416N01       | 22k   |
| R936                    | 6-11009A51        | 1.2k  |
| R937                    | 6-11009A79        | 18k   |
| R938                    | 6-11009A63        | 3.9k  |
| R939                    | 18-80266B02       | variable; 5k  |
| R940                    | 6-11009A63        | 3.9k  |
| R941                    | 6-11009A49        | 1k  |
| R942                    | 6-11009A99        | 120k  |
| R943                    | 6-11009A35        | 270   |
| U901                    | 51-80067C03       | integrated circuit; (see note) dual operational amplifier |
| <b>mechanical parts</b> |                   |   |
| 14-80278B01             |                   | INSULATOR, coupler; 2 used                                |
| 26-80279B01             |                   | SHIELD, coupler   |
| 9-80028A01              |                   | SOCKET, transistor (Q901)                                 |
| 30-80280B01             |                   | THROUGH LOOP coupler                                      |
| 30-80280B02             |                   | PICK-UP LOOP, coupler                                     |

TKN5373A Internal Cable Kit PL-8318-O

| REFERENCE SYMBOL        | MOTOROLA PART NO. | DESCRIPTION  |
|-------------------------|-------------------|--|
| C881 thru 887           | 21-82812H03       | capacitor, fixed: 1000 pF ± 100-0%; 500 V (feed-thru)                            |
| C891 thru 897           | 21-821474         | 470 pF ± 20%; 500 V (feed-thru)  |
| C951, 952, 953          | 21-82812H03       | 20 ± 5%  |
| J801                    | 1-80748D81        | connector, feed-through; ASSEMBLY, power control plate; includes: C951, 952, 953 |
| 64-82405N01             |                   | PLATE, plug  |
| J803                    | 9-82442E01        | connector, receptacle; RECEPTACLE, PA rf out                                     |
| P901                    | 15-83498F15       | HOUSING, 7-contact   |
| P902                    | 15-83498F28       | HOUSING, 3-contact   |
| <b>mechanical parts</b> |                   |  |
| 1-80748D80              |                   | ASSEMBLY, control cable; includes: P902  |
| 29-83499F01             |                   | TERMINAL; 3 used   |
| 42-10217A02             |                   | STRAP tie; 2 used  |
| 1-80748D82              |                   | ASSEMBLY, power control feed-thru; includes: C881 thru 887                       |
| 30-83878K01             |                   | CABLE, 7-conductor shield; 12" used  |
| 1-80748D83              |                   | ASSEMBLY, PA feed-thru plate; includes: C881 thru 887                            |
| 64-80005A01             |                   | PLATE, feed-thru   |
| 1-80748D92              |                   | ASSEMBLY, cable power out; includes: J803  |
| 15-834599               |                   | HOOD, receptacle   |
| 30-83794C01             |                   | CABLE, coaxial (WHT); 4-1/2"   |
| 1-80748D84              |                   | ASSEMBLY, cable interface; includes: P901  |
| 29-83499F01             |                   | TERMINAL; 6 used   |
| 30-83878K01             |                   | CABLE, 2-conductor shielded; 9-1/2"  |
| 1-80753D16              |                   | ASSEMBLY, interface plate; includes: C891 thru 897                               |
| 64-82404N01             |                   | PLATE, RF  |

TRN5141A Power Amplifier Hardware PL-7939-B

| REFERENCE SYMBOL        | MOTOROLA PART NO. | DESCRIPTION                                      |
|-------------------------|-------------------|--|
| C870, 871               | 21-84211B01       | capacitor, fixed: .01 uF, GMV; 250 V (feed-thru) |
| J802                    | 9-82442E01        | connector, receptacle; barrier type; 2 terminal  |
| TB801                   | 31-50378          | strip, terminal; barrier type; 2 terminal        |
| <b>mechanical parts</b> |                   |  |
| 2-131435                |                   | NUT; 4-40 x 1/4 x 3/32"; 2 used                  |
| 3-3375                  |                   | SCREW, tapping; 6-20 x 5/16"; 4 used             |
| 3-115213                |                   | SCREW, machine; 3-48 x 1/4"; 4 used              |
| 3-129890                |                   | SCREW, machine; 10-32 x 3/8"; 6 used             |
| 3-131195                |                   | SCREW, machine; 6-32 x 3/8"; 3 used              |
| 3-138294                |                   | SCREW, tapping; 8-32 x 5/8"; 2 used              |
| 3-138510                |                   | SCREW, machine; 4-40 x 5/8"; 2 used              |
| 4-7681                  |                   | LOCKWASHER, #3 internal; 4 used                  |
| 14-80143A04             |                   | INSULATOR, HB, LB                                |
| 14-82406N01             |                   | INSULATOR, control                               |
| 14-82407N01             |                   | INSULATOR  |
| 26-82323N02             |                   | HEATSINK, PA                                     |
| 29-129882               |                   | LUG, soldering                                   |
| 30-83794C01             |                   | CABLE, coaxial (WHT); 4" used                    |
| 43-82416N01             |                   | SPACER   |
| 64-82986N01             |                   | SPACER, feed-thru                                |
| 15-84146N01             |                   | PANEL, PA  |
| 29-83897M02             |                   | COVER, feedthru                                  |
|                         |                   | TERM, wire receptacle; 2 used                    |

TRN5376A PA Transistor and Hardware Kit PL-7937-B

| REFERENCE SYMBOL        | MOTOROLA PART NO. | DESCRIPTION                          |
|-------------------------|-------------------|--------------------------------------|
| C825 thru 828           | 21-84366F12       | capacitor, fixed: 200 pF ± 5%; 250 V |
| Q801                    | 48-84411L90       | transistor; (see note)               |
| Q802                    | 48-84411L91       | NPN; type M1190                      |
| Q803, 804               | 48-84411L04       | NPN; type M1194                      |
| Q804                    | 48-84411L10       | PNP; type M1110                      |
| R831, 832               | 6-126C01          | resistor, fixed: 10 ± 10%; 1 W       |
| R833                    | 6-127C05          | 15 ± 10%; 2 W                        |
| <b>mechanical parts</b> |                   |                                      |
| 2-7003                  |                   | NUT, 8-32 x 5/16"; 2 used            |
| 3-3375                  |                   | SCREW, tapping; 6-20 x 5/16"; 9 used |
| 3-3398                  |                   | SCREW, tapping; 6-20 x 3/8"          |
| 3-129997                |                   | SCREW, machine; 4-40 x 1/4"          |
| 3-134186                |                   | SCREW, tapping; 6-32 x 5/16"; 4 used |
| 3-138813                |                   | SCREW, machine; 4-40 x 3/8"; 4 used  |
| 3-488006                |                   | SCREW, machine; 6-32 x 1/2"; 4 used  |
| 4-858060                |                   | WASHER, insulator; 4 used            |
| 4-84180C01              |                   | WASHER, shoulder; 1 used             |
| 14-83280M02             |                   | CABLE, 7-conductor shield; 12" used  |
| 15-80066B01             |                   | INSULATOR, transistor                |
| 15-82400N01             |                   | COVER, harmonic filter               |
| 26-83374N04             |                   | SHIELD, harmonic filter              |
| 5-129977                |                   | EYELET                               |

NOTE: For optimum performance, diodes, transistors, and integrated circuits must be ordered by Motorola part numbers.

POWER AMPLIFIER BOARD

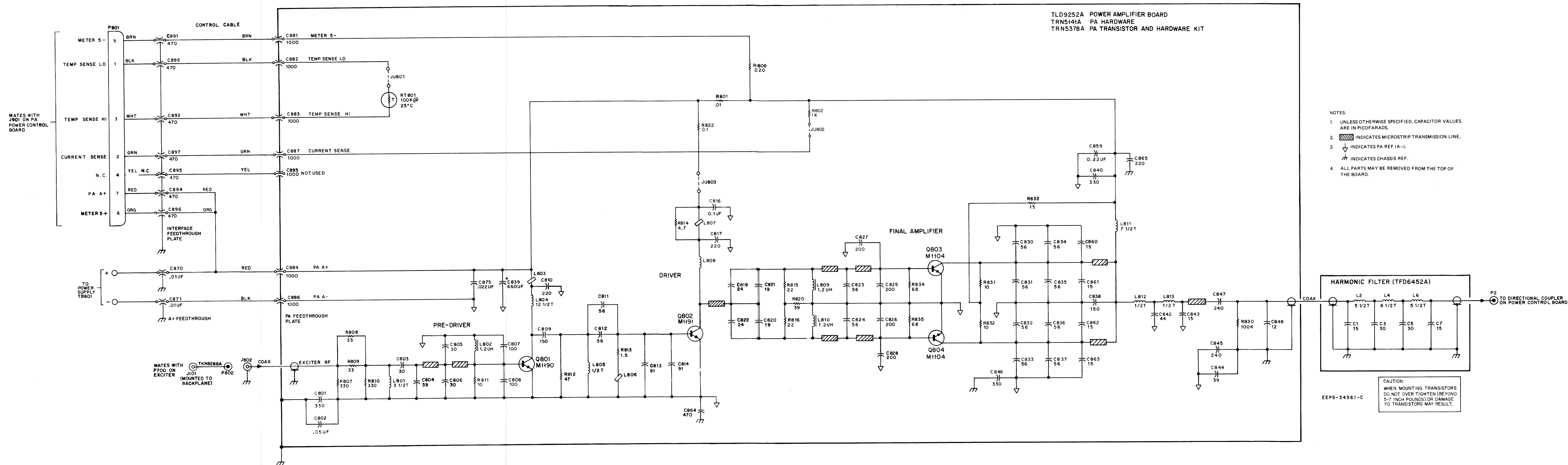



## 1. GENERAL

The TLD2600A Series Power Amplifier (refer to Table 1) consists of the power amplifier chassis and associated hardware, and contains three circuit boards: the power control board, the power amplifier board, and the exciter control voltage regulator board. The following sections detail the theory of operation and maintenance information for the power amplifier circuitry. Because the setting of the power levels is affected by the alignment of the exciter, the power set procedure is a part of the overall transmitter alignment procedure given in the Transmitter section of this manual.

*Table 1.  
Power Amplifier Frequency Range*

| Model    | Frequency Range (MHz) |
|----------|-----------------------|
| TLD2601A | 132-150.8             |
| TLD2602A | 150.8-162             |
| TLD2603A | 162-174               |

## 2. THEORY OF OPERATION

### 2.1 POWER AMPLIFIER BOARD

(Refer to Figure 1 and schematic diagram)

**2.1.1** This series of power amplifiers requires a 400 mW rf input from the exciter board. This input is passed through a ferrite step-down transformer (to match the input impedance to the first stage) to the gain-controlled amplifier stage. The external power control circuit which drives the control stage transistor determines the gain of this stage. The power control circuit monitors the output of the final stages of the power amplifier and the load condition.

**2.1.2** The output of the gain-controlled amplifier is passed through a fixed-tuned broadband matching network and applied to the pre-driver stage. A second ferrite transformer is utilized to match the singleended output of the pre-driver stage to the input of the push-pull driver stage. The output of the driver stage is split by a pair of transformers to drive each of the pushpull final power amplifier stages. The output from each final

stage is stepped up in impedance by ferrite transformers and paralleled to provide the 50 ohm output impedance to match the input impedance of the harmonic filter.

**2.1.3** Pin 1 of the metering receptacle provides a means of checking the incoming signal from the exciter. Pin 2 permits observation of the drive output of the first stage and an indication of the operation of the pre-driver stage. Pins 3 and 4 reflect the output drive signal and operation of the two push-pull power amplifier stages. Reference position A on a Motorola Portable Test Set uses pin 7 of the metering socket as an A+ reference against which the outputs of pins 1, 2, 3, and 4 are checked. Switch the test set to reference position B which uses pin 6 as a reference and then switch to meter position 5. This provides a reading across a calibrated resistor through which the current is drawn by the final amplifier stages.

### 2.2 POWER CONTROL BOARD FUNCTIONAL THEORY OF OPERATION

**2.2.1** Refer to the loop block diagram, Figure 2. The circuitry operates as a control loop which continually monitors the output from the final stages of the transmitter power amplifier and controls that output by regulating the gain of the first stage of the power amplifier.

**2.2.2** Refer to the block diagram, Figure 3. The output of the integrated circuit differential amplifier, amplified by the dc amplifier, is the controlling input to the power amplifier board.

**2.2.3** The output of the differential amplifier is determined by the potentials present on the non-inverting (+) and inverting (-) inputs. These potentials are developed by the power control board circuitry in the following manner.

**2.2.4** When the impedances of the antenna circuitry (load) and the power amplifier are matched (a VSWR of 1:1), a bias voltage produced by the dc reference bias circuitry is placed on the inverting input (also called the "reference input") of the differential amplifier (see Figure 6).

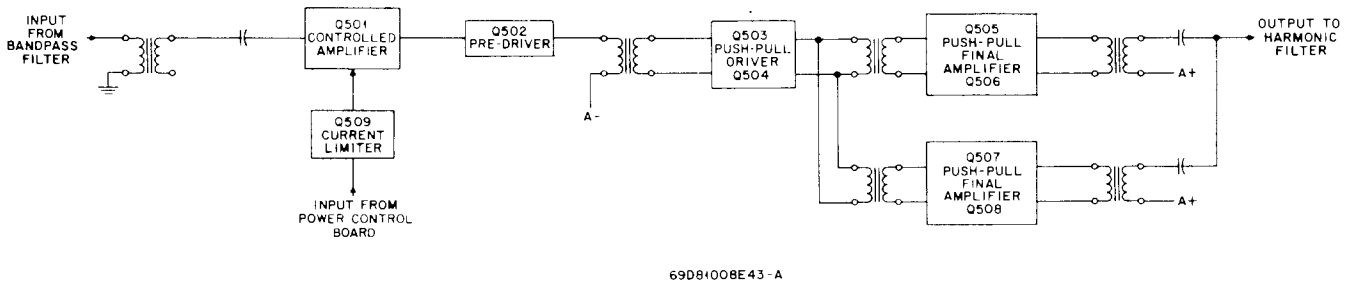

Figure 1. Block Diagram

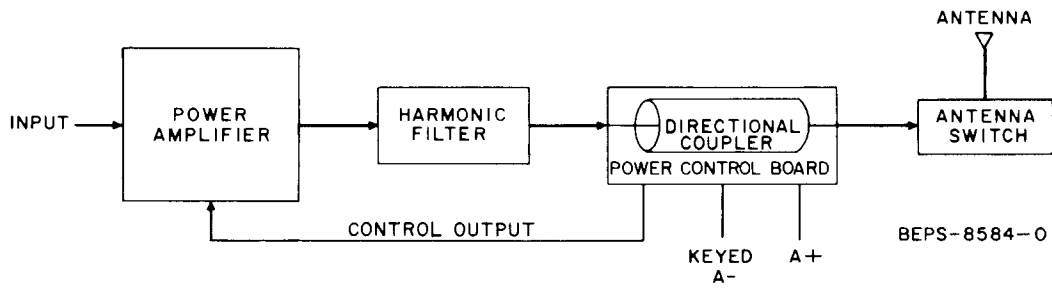

Figure 2. Loop Block Diagram

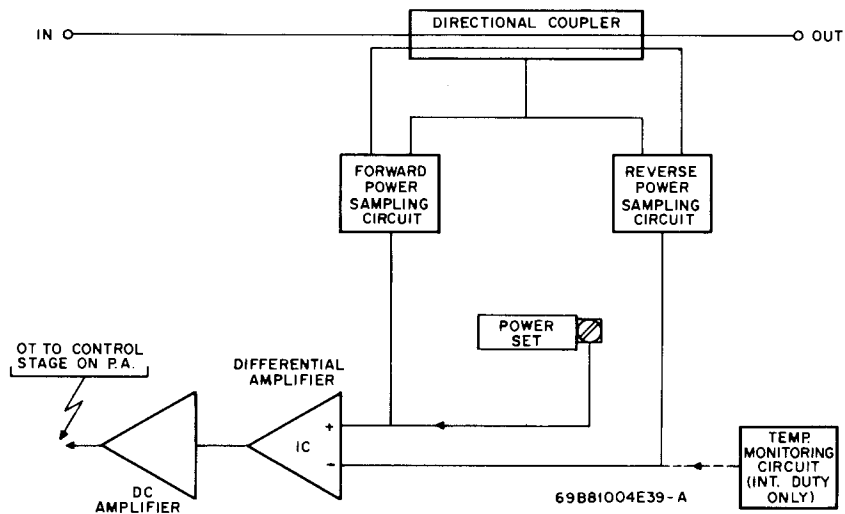

Figure 3. Power Control Board Block Diagram

**2.2.5** When the transmitter is keyed, the forward (output) power from the final stages of the power amplifier is fed through the directional coupler to the antenna circuit. This flow of power is sampled by the forward power sampling circuitry and places a bias, proportional to the forward power, on the noninverting input (pin 5) of the differential amplifier. The POWER SET potentiometer is then adjusted, changing the potential on the non-inverting input. As this voltage changes, relative to the reference input voltage, the output of the differential amplifier changes, in turn changing the loop control level and therefore the output of the power amplifier.

**2.2.6** Once the power has been set to the proper level, any change in the output power will be instantly corrected by the circuitry. If the power increases, the increase causes the differential amplifier output voltage to increase, decreasing the output from the dc amplifier which decreases the gain of the power amplifier until the output returns to the preset level. A decrease in transmitter power amplifier output causes the reverse action.

**2.2.7** Any power reflected back from the antenna circuit is detected by the reverse power sampling circuit. Reverse power causes a negative current to flow, which, in turn, decreases the potential on the reference input of the differential amplifier. Therefore, increasing levels of reflected power will cause the transmitter power output to be decreased to a safe level.

## **2.3 POWER CONTROL BOARD DETAILED THEORY OF OPERATION**

### **2.3.1 Bias Circuitry**

Since the power control board has the capability to regulate the output of the transmitter power amplifier from a completely cut-off state to above the rated output power, a definite controlled output level is necessary whenever the transmitter is keyed. The desired controlled output level is determined by bias voltages present on the inverting and non-inverting inputs of the differential amplifier IC601 (see Figure 4). Under normal operating conditions (1:1 VSWR; 100% rated power out) the bias on the differential amplifier inputs are developed as described in the following paragraphs.

#### **2.3.1.1 Voltage Regulator and Main Divider Line**

Refer to Figure 5. The A+ supply to the board is regulated by a series regulator circuit providing a nominal voltage of 8.0 volts. The Zener diode holds the base of the series pass transistor at a fixed potential. The series pass transistor operates as a variable resistor to hold the input to the reference circuitry constant. The divider consisting of the two resistors and the diode provides the proper voltage tap points for the secondary voltage divider networks. All 220 pF capacitors in the board are used as rf bypasses.

#### **2.3.1.2 Reference Bias Circuit**

Refer to Figure 6. The reference bias is developed (with a 1:1 VSWR) by the voltage divider made up of two resistors and a diode between the regulated supply voltage and the switched A- source. Since A+ is applied to the board continuously and A- is only applied when the transmitter is keyed by the push-to-talk switch, the larger capacitor connected between the inverting input and keyed A- provides a time constant which allows the inverting input bias to build up slowly when power is first applied. This prevents full power output from occurring until the leveling circuitry can react and reach a quiescent level.

#### **2.3.2 Directional Coupler**

The directional coupler measures the voltage and the current traveling in both directions. The detection of forward (output) power causes a proportional voltage bias that is combined with the voltage-divider generated bias to set the potential on the non-inverting input of the differential amplifier. Any reverse power detected causes the VSWR circuitry to decrease the power output.

#### **2.3.3 Protection Circuitry**

##### **2.3.3.1 Forward Power Bias and Detection Circuit**

Refer to Figure 7. The forward power reference voltage divider comprised of two resistors and two potentiometers provides a stable potential that supplies a dc bias to the non-inverting input of the differential amplifier. With an approximately correct power output from the final stages of the power amplifier, a dc level proportional to that power is produced by the forward power detector circuit, which, in combination with the voltage developed by the voltage divider, produces a bias on the non-inverting input that can be adjusted by the POWER SET potentiometer. The POWER LIMIT control is preset to prevent over-dissipation if the POWER SET control should be set to maximum. (Refer to the CAUTION preceding maintenance information in this section.) The dc bias value will be determined by the power amplifier output and, with no reflected power (VSWR 1:1), balanced against the reference bias present on the inverting input of the differential amplifier. Once the bias has been set, and change in power output will change the bias on the non-inverting input causing the differential amplifier to compensate for the deviation. The forward power detector circuit (refer to Figure 8) detects rf power flowing through the directional coupler when the transmitter is keyed, and causes a small proportional current flow in the forward power sampling circuit. The diode converts the rf sample into a pulsating dc voltage and the dc filter removes the ripple. This is the dc voltage which is added to the dc bias already applied to the non-inverting input of the differential amplifier from the secondary divider circuitry.

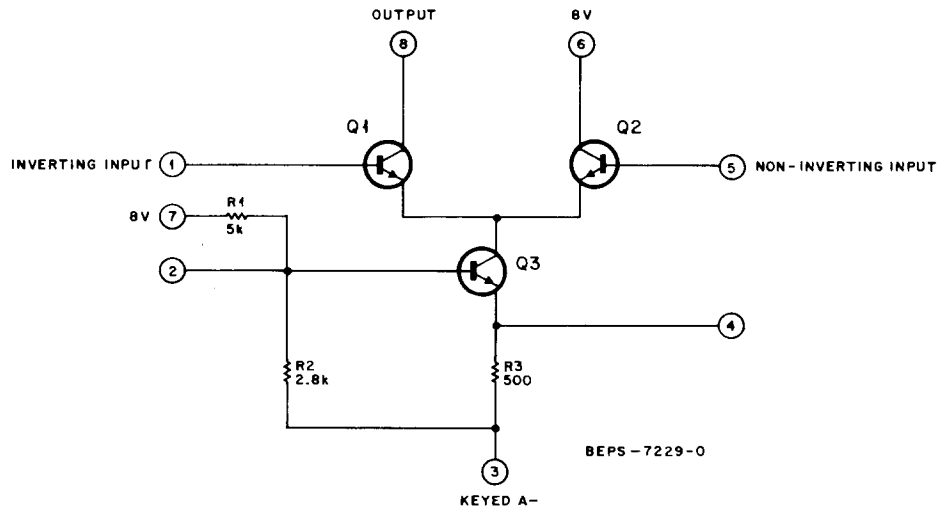

Figure 4. IC601 Schematic Diagram

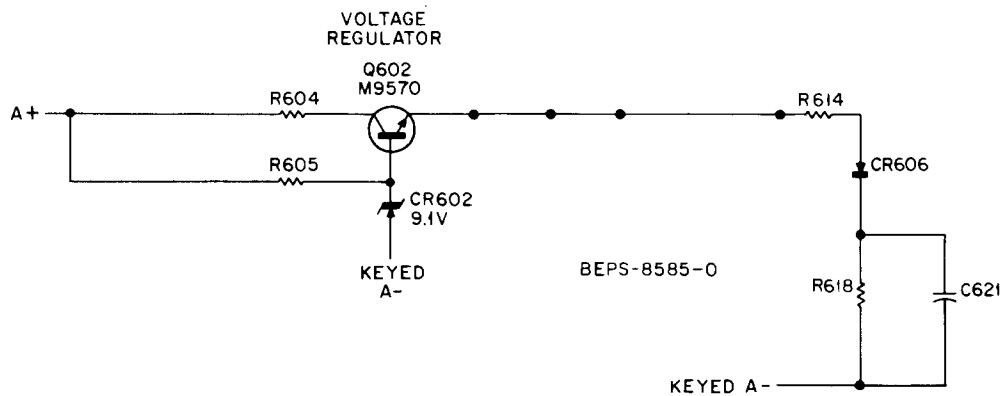

Figure 5. Voltage Regulator and Main Divider Line

### 2.3.3.2 VSWR — Reverse Power Detection Circuit

Since the power control board is now operating correctly with the proper amount of forward power and the correct biases, the detection of reflected power causes a decrease in the power amplifier's output in the following manner.

Refer to Figure 9. The components of the reverse power detector circuit function the same as those in the forward power detector. The voltage divider develops a bias voltage that isn't quite enough to forward bias the diode that makes up one-half of a diode "OR" gate. When reflected power is detected, the resultant negative-going dc level lowers the dc bias level and the combination of the two forward bias the diode. The negative-going dc level on the inverting input increases the output voltage of the differential amplifier, decrease

ing the dc control output to protect the final stages of the power amplifier.

### 2.3.3.3 DC Level Output Amplification

The output of the differential amplifier is applied to the base of a voltage-inverting transistor amplifier whose output supplies the output control current. As the forward power increases above the normal value, the output of the differential amplifier increases proportionally. Since the dc level is increasing the base, the PNP transistor conducts less and the potentials across the output load resistor, and on the control output line, decrease.

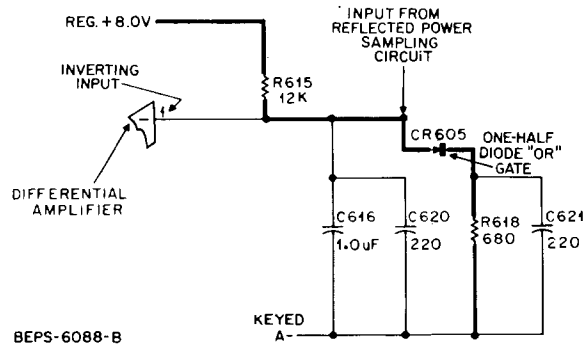

Figure 6. Reference Power Bias Circuit

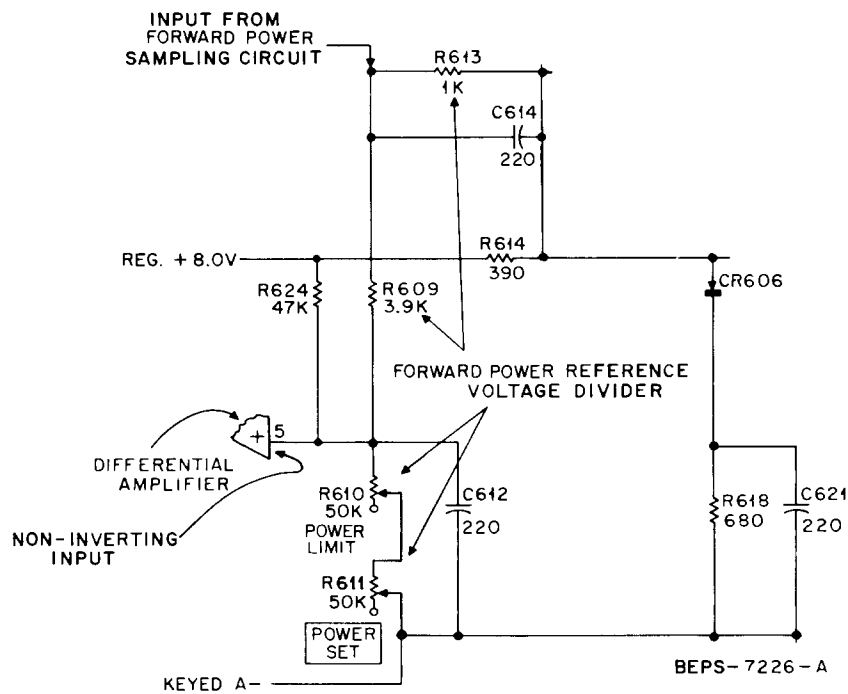

Figure 7. Forward Power Bias Circuit

### 3. MAINTENANCE

#### 3.1 POWER AMPLIFIER BOARD

##### 3.1.1 General

**NOTE**

Because of the complexity involved and time required to remove the PA board, compared to plug-in boards, it is not recommended that the PA board be removed. Proper troubleshooting tech-

**NOTE (Cont'd.)**

niques will usually locate defective components "on the spot."

This section of the manual provides the maintenance shop procedures for the PA board. It assumes that preliminary tests have already localized the trouble to the PA board. These procedures include measurements with a Motorola portable test set, a VOM, a complete set of performance tests, and extensive troubleshooting procedures.



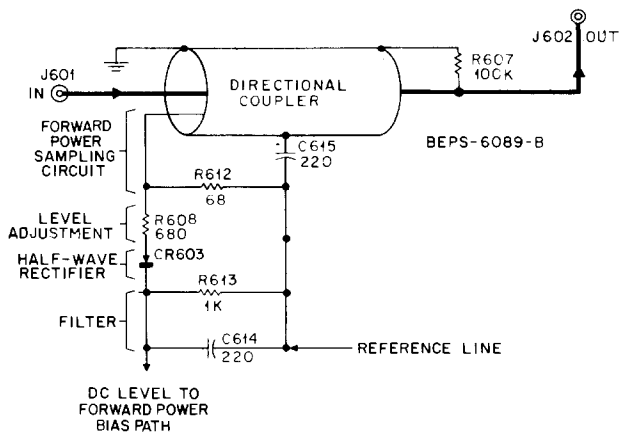

Figure 8. Forward Power Detector Circuit

### CAUTION

The PA board must be installed in the transmitter for testing to provide the necessary power, ground, control, heat sinking and signal connections.

### 3.1.2 Recommended Test Equipment

The following test equipment is the minimum required for troubleshooting and adjusting the PA.

- Motorola S1056B through S1059B Portable Test Set and Model TEK-37 or TEK-37A Adapter Cable. The portable test set is required for checking each stage for proper operation.
- A Motorola Solid-State DC Multimeter or a 20,000 ohm-per-volt multimeter should be used, however a low impedance multimeter is acceptable for dc voltage measurements only.
- Motorola T1013A RF Load Resistor (dummy load) or equivalent.

### 3.1.3 Test Set Metering

The PA is equipped with a metering receptacle which allows five major test points to be measured. PA metering can be made at each of the five test points by merely rotating a selector switch on the optional station meter kit or on the test set. A failure in almost any portion of the PA will produce a low or zero meter reading for one or more of the test points. Improper alignment will also cause improper meter readings.

### 3.1.4 Using the Portable Test Set

3.1.4.1 To make the measurements, the portable test set must be connected to the station as follows.

Step 1. Set the function selector switch of the portable test set to the XMTR position.

Step 2. Set the meter reversing switch of the test set to the METER REV position, the selector switch to position 1, and REF switch to position A.

Step 3. Connect the 20-pin meter cable plug to the test set. When the test set is not in use, disconnect the 20-pin plug to conserve battery life. The plug acts as an on-off switch completing the battery circuit.

Step 4. Connect the red "control" plug of the adapter cable to the control receptacle on the remote control board. Connect the white "metering" plug of the adapter cable to the receptacle on the PA circuit board.

Step 5. The entire transmitter is necessary for testing PA boards including the power control board for proper control.

Step 6. The output of the station must be terminated in one of three types of loads:

- The antenna load.
- A dummy load such as Motorola's T1013A RF Load Resistor.
- An RF wattmeter.

### NOTE

A dummy load is preferred to the antenna to eliminate the possibility of shutback by the power control board due to a defective antenna.

Step 7. Turn the station ON.

Step 8. Key the transmitter with the XMTR ON button on the test set. Observe the meter. Unkey the transmitter.

Step 9. Set the selector switch to positions 2, 3, & 4; then switch to reference position B and meter position 5 respectively, keying the transmitter and observing the meter reading for each. Refer to Table 2. On multi-frequency stations, repeat the readings for each frequency. An analysis of the meter readings for determining whether each circuit is good or bad follows.

3.1.4.2 Each time maintenance is performed on the PA the readings should be compared with the previous set of readings. Any degradation of performance will quickly be noted. Often, a lower reading may indicate

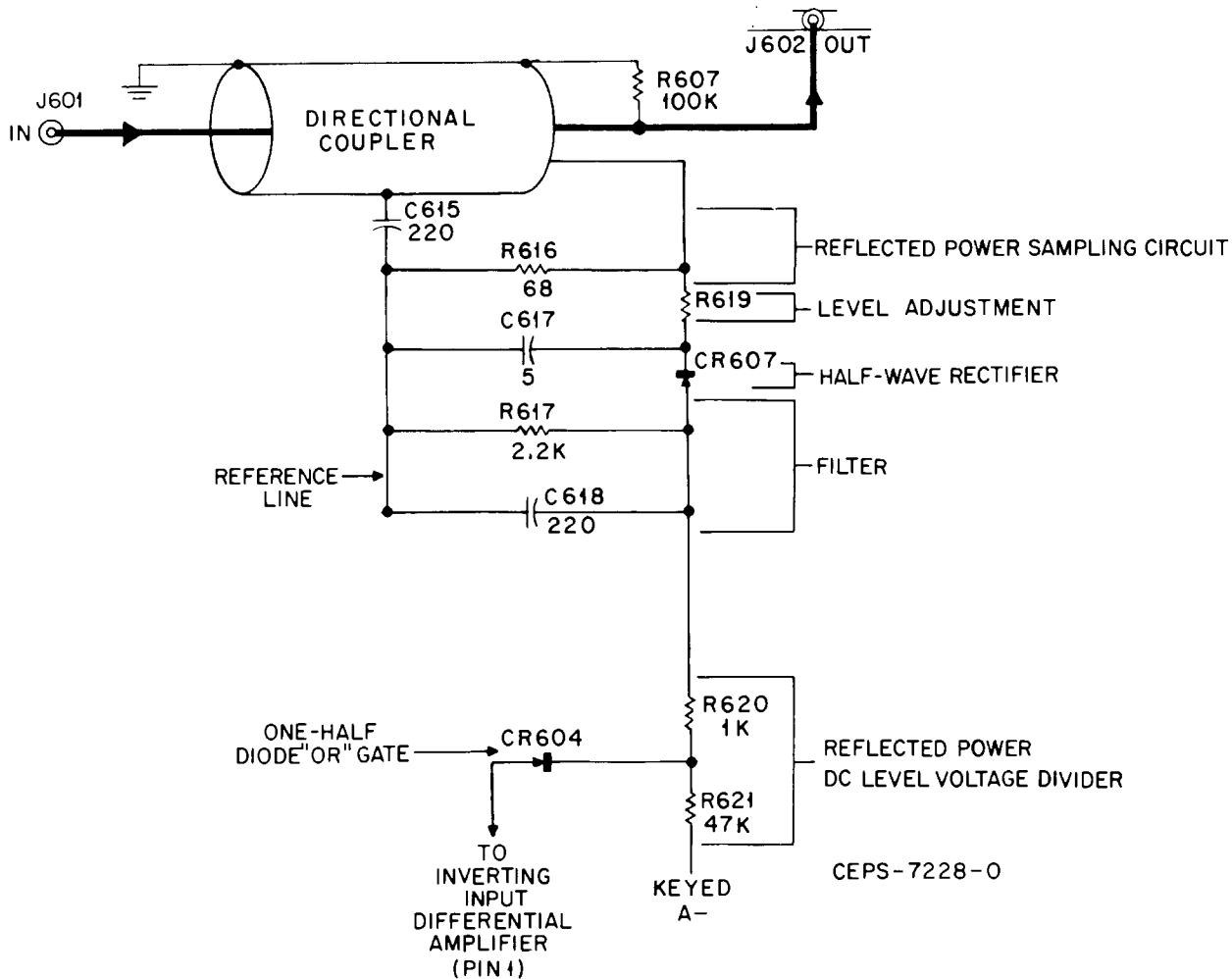

Figure 9. Reverse Power Detector Circuit

an impending failure and corrective action may be taken before the circuit fails entirely.

### 3.1.5 Performance Tests

Step 1. No performance test of the power amplifier is required other than rf power output from the station as a whole. Before checking power output:

- The exciter board should be known to be operating normally.
- The power control board should be known to be functioning normally.

Step 2. Key the transmitter and observe power out, which should be 100 watts or value set from 50 to 100 watts depending upon licensing.

## 3.2 POWER CONTROL BOARD

### CAUTION

The power control board is incorporated in the transmitter to provide protection for the rf power transistors under environmental conditions such as voltage, load variation, and device variations. In order for the circuitry to operate properly and provide protection it is necessary to set the power output control (POWER SET) in accordance with the station alignment procedure.

### 3.2.1 General

3.2.1.1 Two basic maintenance approaches may be used for localizing and replacing trouble in these radio sets.

Table 2. Power Amplifier Board Metering

| Selector Switch Position | Reference Switch Position Portable Test Set Only | Minimum Meter Readings   | Circuit Metered  | If Low, Defective Circuit Is: (See Troubleshooting Charts)  |
|--------------------------|--|--------------------------|--|---|
| 1                        | A  | 10 $\mu$ A               | Exciter Output (input to Controlled Amplifier Q501)            | Exciter output, input circuitry of controlled amplifier stage Q501.                               |
| 2                        | A  | 5 $\mu$ A                | Input of Pre-driver Stage (Q502)                               | Output of controlled amplifier stage input circuitry of predriver stage.                          |
| 3                        | A  | 10 $\mu$ A               | Input of Final Amplifier Stage Q505, Q506                      | Input of Q505, Q506 stages, output of driver stage (Q502, Q503), output of pre-driver stage Q502. |
| 4                        | A  | 10 $\mu$ A               | Input of Final Amplifier Stage Q507, Q508                      | Input of Q507, Q508 stage output of driver stage Q502, Q503. Output of pre-driver stage Q502.     |
| 5 (or 2)                 | B  | 29 $\mu$ A max.<br>105 W | Total Current in Final Amplifier Stages Q505, Q506, Q507, Q508 | Output of final amplifier stages Q505-Q508, power control board antenna switch, antenna.          |
| 6 (or 3)                 | B  | 12 V<br>(0-30 V scale)   | Final Amplifier Stage  | Final amplifier stage A+ or A- input.   |

- Replace the defective circuit board with a spare and return the defective board to a maintenance shop for repair.
- Isolate and repair the trouble on the spot. This approach must be used if spares are not available.

**3.2.1.2** Regardless of the maintenance approach used, a few simple tests on the overall radio set will localize the trouble to the power control board if it is defective. These procedures are given elsewhere in the manual. This section of the manual provides the maintenance shop level procedures for the power control circuitry. It assumes that preliminary tests have already localized the trouble to the power control board. These bench test type procedures include measurements with a Motorola portable test set, a simple set of performance tests, and complete troubleshooting procedures including step-by-step circuit check-out.

### 3.2.2 Recommended Test Equipment

The following test equipment is the minimum required for troubleshooting and adjusting the board. All such equipment is battery operated. When ac operated equipment is used, the ground lead must not be electrically connected to ac line ground.

- Optional station metering or Motorola S1056B through S1059B Portable Test Set and Model TEK-37 or TEK-37A Adapter Cable. (The meter or portable test set is necessary to monitor forward and reverse power detectors.)
- Motorola Solid-State DC Multimeter or equivalent. A 20,000 ohm-per-volt multimeter may be used but a low impedance volt-ohm meter may not be used. This meter is used for measuring dc voltages and resistance.

- Motorola T1013A RF Load Resistor (Dummy Load) or equivalent.

### 3.2.3 Metering

The power control board is equipped with a metering receptacle which allows three major test points (forward power, reflected power and control current) to be measured. Refer to the troubleshooting charts or the schematic diagram for the correct meter indications.

### 3.2.4 Using Portable Test Set

Step 1. Set the function selector switch of the portable test set to the XMTR position.

Step 2. Set the meter reversing switch of the test set to the METER REV position.

Step 3. Set the REF switch to position A or B.

Step 4. Connect the 20-pin meter cable plug to the test set. When the test set is not in use, disconnect the 20-pin plug to conserve battery life. The plug acts as an on-off switch completing the battery circuit.

Step 5. Connect the red "control" plug of the adapter cable to the control receptacle on the remote control circuit board. Connect the white "metering" plug of the adapter cable to the receptacle on the power control-board.

Step 6. The output of the power control board must be terminated in one of three types of loads.

- The antenna load.
- A dummy load such as Motorola's T1013A RF Load Resistor.
- An RF wattmeter.

**NOTE**

A dummy load is preferred to the antenna to eliminate the possibility of shutback due to a defective antenna.

Step 7. Turn the station ON.

Step 8. Set the selector switch of the test set to position 1 and key the transmitter with the XMTR ON button on the test set. Observe the wattmeter, or the meter reading if a dummy load is used or if the antenna is used. Unkey the transmitter. Under normal conditions at rated power out, meter 1 should read between 15 uA and 45 uA typically. Refer to Table 3.

**3.2.5 Performance Test, Power Set Control**

This control allows the power output of the radio set to be varied from zero (0) power out with the control fully counterclockwise to greater than the rated output.

**CAUTION**

For proper operation of the protection circuitry, it is imperative that the POWER SET control never be left in a position that exceeds rated power output.

Refer to the power amplifier tune-up procedure.

Step 1. Key the transmitter.

Step 2. Adjust the POWER SET control until the rated power output is reached.

Step 3. Unkey the transmitter.

**4. TROUBLESHOOTING PROCEDURES**

**4.1 GENERAL**

If a problem has been localized to either the power amplifier or power control board decks, several checks can be made prior to extensive troubleshooting.

**4.2 VISUAL**

Visually check for obvious physical defects such as broken leads, broken plating, broken or disconnected components or overheated parts. Before any attempt is made to change parts, the circuit should be checked to insure that the problem causing the original failure has been identified and corrected, otherwise damage to the new part may occur.

**4.3 VOLTAGE CHECKS**

Check for A+ and A- at the feedthrough connections and for proper voltages at the collectors of each transistor. Certain defects such as broken plating, broken leads etc. may not be obvious to a visual inspection.

**4.4 TROUBLESHOOTING**

**4.4.1** If test set readings are abnormal or tests indicate subnormal performance, a logical troubleshooting procedure is required to isolate the defective component efficiently. The accompanying troubleshooting chart summarizes these results in a logical sequence. A few voltage and resistance checks in the suspected circuit should readily isolate the defective component. Note that all power for the circuits in the PA and power control board is from A- referenced to A+ (not to chassis ground, this feature allows operation from positive or negative ground power sources when an optional positive ground converter is used).

**CAUTION**

Due to the voltage requirements of PNP transistors, all "rf ground" plating is A+ and is "hot" with respect to chassis ground in negative ground applications. Because of this, caution should be used to prevent connection of "ground" plating on the PA board to chassis ground, either directly or by the use of test equipment ground leads. If ac operated test equipment is used, the ground lead must not be electrically connected to ac line ground.

*Table 3. Power Control Board Metering*

| Selector Switch Position | Reference Switch Position (See Note) | Normal Meter Readings | Function   |
|--------------------------|--------------------------------------|-----------------------|--|
| 1                        | A<br>(Meter Reverse On)              | 15-45 uA              | Indicates forward power output.  |
| 2                        | A                                    | 10 uA max.            | A meter reading higher than the normal range indicates reflected power caused by a defective antenna, antenna switch, or cables.   |
| 5                        | B<br>(Meter Reverse On)              | 50 uA max.            | Indicates the relative level of drive sent to the PA on the blue control lead. A reading of greater than 35 uA indicates the power control board is set for a higher power than the radio is capable of supplying. |

**METERING NOTE**

Alignment may be performed using a Motorola S1056B thru S1059B Portable Test Set. The OSC. & METER REV. SWITCH column refers to portable test set usage.

**4.4.2** The schematic diagrams of the PA board and power control board contain the voltage readings required for troubleshooting. The readings are typical for normal operating conditions at rated power output for the radio. Refer to the troubleshooting charts and the schematics when a defect is suspected.

## **5. REPAIR PROCEDURES**

### **5.1 RESISTANCE MEASUREMENT OF TRANSISTORS IN PUSH-PULL PAIRS**

Due to the fact that transistors in push-pull pairs are dc connected at both base and emitter, BOTH devices should be measured when a defect in the pair is suspected.

### **5.2 TRANSISTOR REMOVAL PROCEDURE**

Step 1. Unscrew both mounting screws from the base of the transistors. The nuts (for the mounting screws) on the reverse side of the shelf are captivated and will not fall out.

Step 2. Remove excess solder from around transistor tabs with a vacuum bulb type de-soldering device.

Step 3. Gently lift each lead, one at a time while applying heat.

Step 4. When all four leads are loose from the board carefully lift out the transistor.

### **5.3 TRANSISTOR INSTALLATION PROCEDURE**

Step 1. Pre-tin underside of each transistor lead.

Step 2. Apply a light coat of Wakefield Thermal Compound to the underside of the transistor mounting base and to the heat sink.

Step 3. Install the transistor making sure that all collector leads face the proper direction. Refer to the circuit board detail.

Step 4. Screw down the two mounting screws securely.

Step 5. Solder each transistor lead one at a time to the circuit board. The use of a generous amount of solder will insure a good contact of the entire tab to the board. Use care that solder does not bridge to other plating or that solder does not flow into the cutout in the circuit board.

### **5.4 PROCEDURES FOR RESISTANCE MEASUREMENTS OF TRANSISTORS**

Step 1. Set ohmmeter to RX1, RX10 or RX100 scale (preferably RX10 if available).

Step 2. Measure the resistance from lead to lead as described in (a) thru (c). Should any indication be observed in measurements (a) or (c), the transistor is defective and should be replaced.

- With the positive probe on the base, no indication (very high impedance) should be observed when the negative probe is touched to the collector or emitter. (Reverse drop measurement.)
- With the negative probe on the base, a relatively low impedance should be observed when touching the positive probe to the collector and emitter. (Forward drop measurement.)
- No indication should be observed from collector to emitter regardless of the polarity of the ohmmeter probes.

# POWER CONTROL BOARD TROUBLESHOOTING CHART

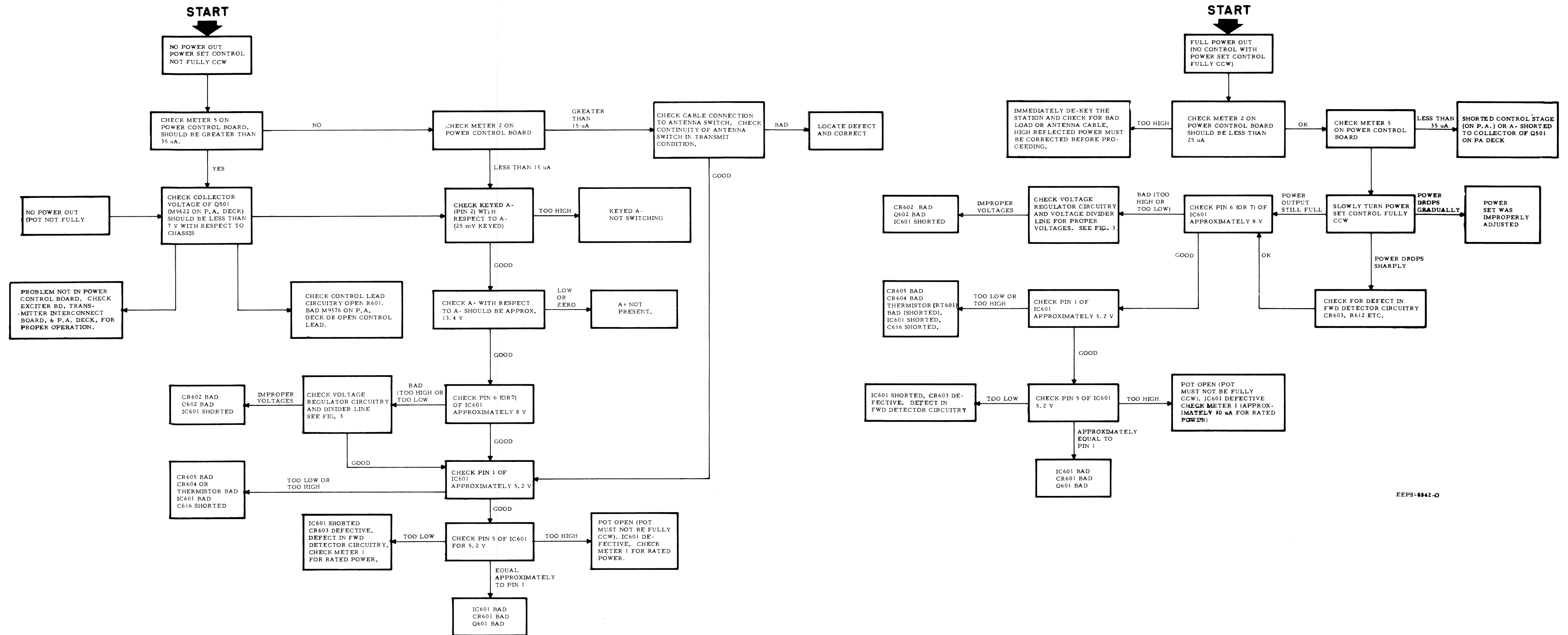

EEPS-0042-0

# POWER AMPLIFIER TROUBLESHOOTING CHART

## POWER AMPLIFIER TROUBLESHOOTING CHART

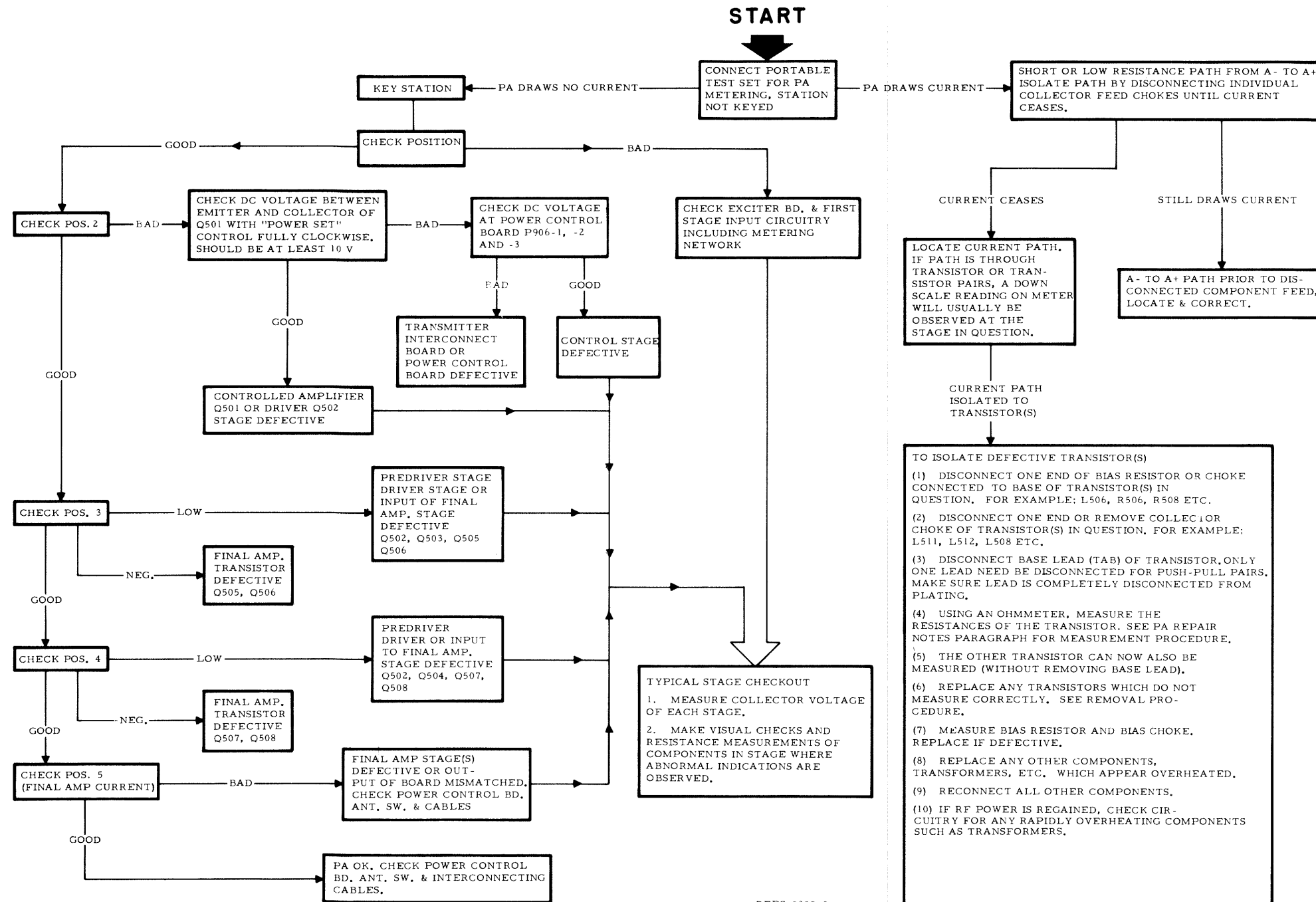

# parts list

TRN5566A Input Bracket PL-8193-B

| REFERENCE SYMBOL        | MOTOROLA PART NO.          | DESCRIPTION  |
|-------------------------|----------------------------|--|
| C560, 561, 562          | 21-410115                  | <b>capacitor, fixed: +100-0%:</b><br>unless otherwise stated<br>220 pF ± 20%; 500 V<br>.01 uF; 250 V<br>1000 pF; 500 V (feed-thru)   |
| C565, 566               | 21-84211B01                |  |
| C950 thru 953           | 21-82812H03                |  |
| J501                    | 9-84968D01                 | <b>connector, receptacle:</b><br>female; single-contact<br>assembly bracket; includes:<br>C950, 951, 952, 953<br>BRACKET, PA input<br>SOCKET, transistor<br>WASHER, solder; 4 used |
| J801                    | 1-80764D32                 |  |
|                         | 7-84355N01                 |  |
|                         | 9-84935D01                 |  |
|                         | 4-83755H01                 |  |
| P901                    | 15-83498F41<br>29-83499F01 | <b>connector, plug; includes:</b><br>HOUSING, 4-position<br>TERMINAL; 4 used   |
| Q509                    | 48-869627                  | <b>transistor: (see note)</b><br>type M9627<br>NPN; type M9806   |
| Q901                    | 48-869806                  |  |
| TB1                     | 31-50378                   | <b>terminal board:</b><br>barrier type-2 terminals   |
| W501                    | 1-80727B92<br>30-83794C01  | <b>assembly cable:</b><br>assembly rf-input, includes: J501<br>CABLE, coaxial, WHT; 8" used  |
| <b>mechanical parts</b> |                            |  |
|                         | 2-115968                   | NUT; 1/4-28 x 3/8 x 1/8"; 2 used   |
|                         | 3-3360                     | SCREW, tapping; 6-20 x 1/2"; 2 used  |
|                         | 3-139905                   | SCREW, tapping; 8-15 x 3/4"; 2 used  |
|                         | 3-129841                   | SCREW, machine; 4-40 x 1/4"  |
|                         | 4-7557                     | WASHER, flat; .172 x .375 x .033"; 2 used  |
|                         | 4-7678                     | WASHER, lock; 1/4" external; 2 used  |
|                         | 4-84180C01                 | WASHER, insulator  |
|                         | 14-865875                  | INSULATOR, transistor  |
|                         | 14-84391F01                | INSULATOR, transistor  |
|                         | 29-5223                    | LUG, soldering; 2 used   |
|                         | 43-82980N01                | STANDOFF; 2 used   |
|                         | 75-10605A04                | CUSHION, foam  |

TRN5585A Exciter Control Voltage Regulator PL-8192-O

| REFERENCE SYMBOL        | MOTOROLA PART NO. | DESCRIPTION                                 |
|-------------------------|-------------------|---|
| C301, 302               | 21-11021H06       | <b>capacitor; +80-20%; 50 V:</b><br>.033 uF |
| J901                    | 28-82984N04       | <b>connector, plug:</b><br>male, 4-contact  |
| R304                    | 18-83083G11       | <b>resistor, variable:</b><br>2.5k          |
| <b>mechanical parts</b> |                   |   |
|                         | 9-80028A01        | SOCKET, 3 pin                               |

TKN8336A Cable Power Amplifier PL-8191-A

| REFERENCE SYMBOL | MOTOROLA PART NO. | DESCRIPTION   |
|------------------|-------------------|---|
| J803             | 9-844509          | <b>connector:</b><br>female; single-contact (BNC)<br>male; single-contact (phono) |
| P602             | 28-82365D03       |   |
| W601             | 1-80727B96        | <b>assembly rf output includes:</b><br>J803 and P602                              |
|                  | 30-82921H01       | CABLE, coaxial, WHT; 5" used  |

# TRN5585A EXCITER CONTROL VOLTAGE REGULATOR

## SCHEMATIC DIAGRAM, CIRCUIT BOARD DETAIL, & PARTS LIST

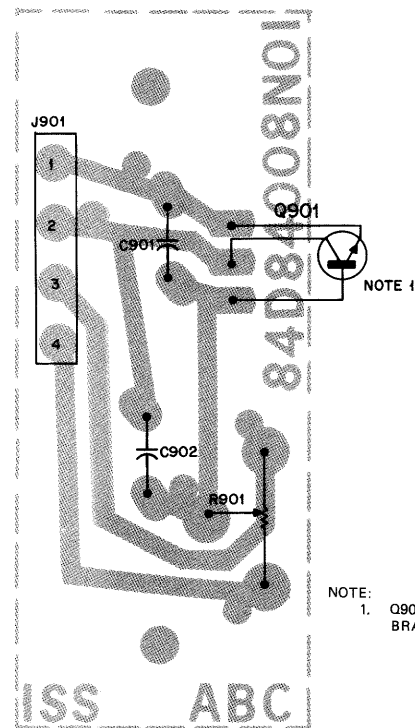

NOTE:  
1. Q901 IS MOUNTED TO AN INPUT BRACKET WHICH IS P/O TLN2424A

SOLDER SIDE = BD-BEPS-35245-0  
OL-BEPS-35246-0

SHOWN FROM SOLDER SIDE

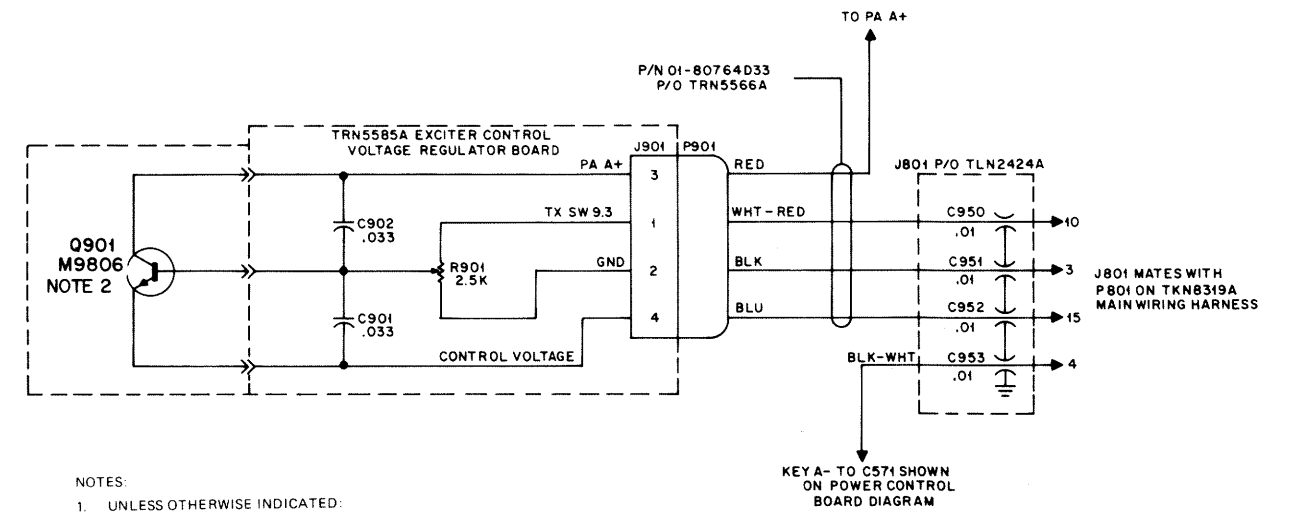

NOTES:  
1. UNLESS OTHERWISE INDICATED:  
RESISTOR VALUES ARE IN OHMS;  
CAPACITOR VALUES ARE IN  
MICROFARADS.  
2. Q901 IS MOUNTED TO AN INPUT  
BRACKET WHICH IS P/O TLN2424A.

BEPS-35244-0

### Model Complement

| Model    | Kit      | Description                            |
|----------|----------|--|
| TLN2424A |          | Power Amplifier Input Bracket Assembly |
|          | TRN5566A | PA Input Bracket                       |
|          | TKN8336A | Power Amplifier Cable                  |
|          | TRN5585A | Exciter Control Voltage Regulator      |



# TLD5960A POWER CONTROL BOARD

SCHEMATIC DIAGRAM,  
CIRCUIT BOARD DETAIL, & PARTS LIST

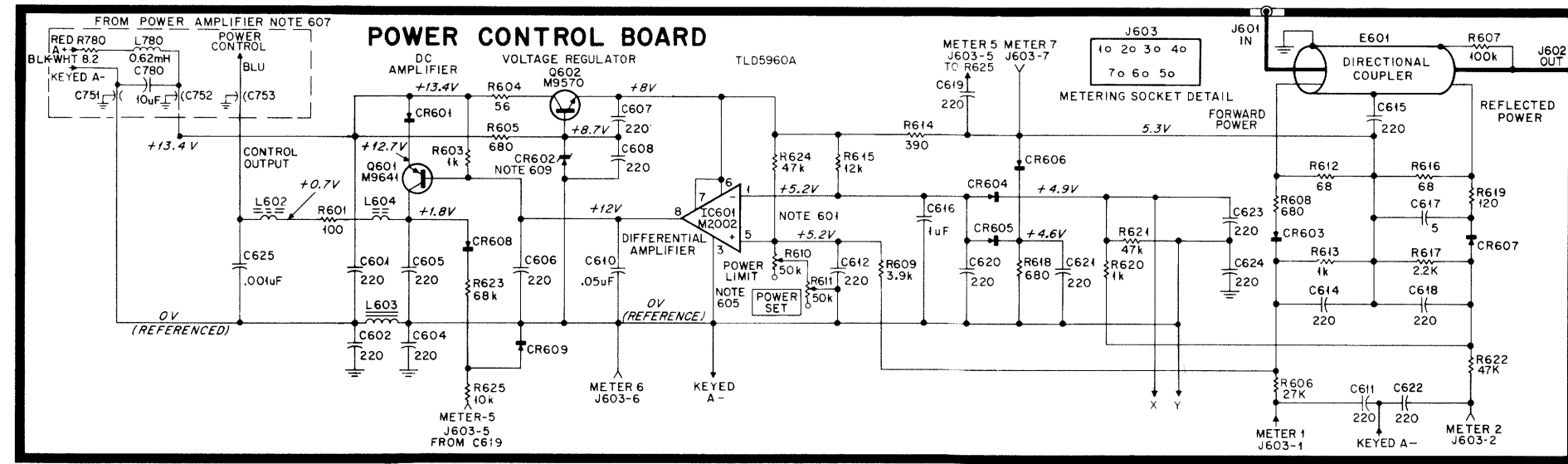

EEPS-35250-0

**NOTES:**

- 601. Voltages at pins 1 and 5 should differ by less than 50 mV.
- 603. Typical Voltages under normal operating conditions.
- 604. Unless otherwise stated: capacitor values are in picofarads.
- 605. Factory adjustment.
- 607. Not part of or mounted on power control board. Part of Model TRN5577A P.A. casing and hardware.
- 609. On model TLD5960A CR602 is a hybrid assembly.

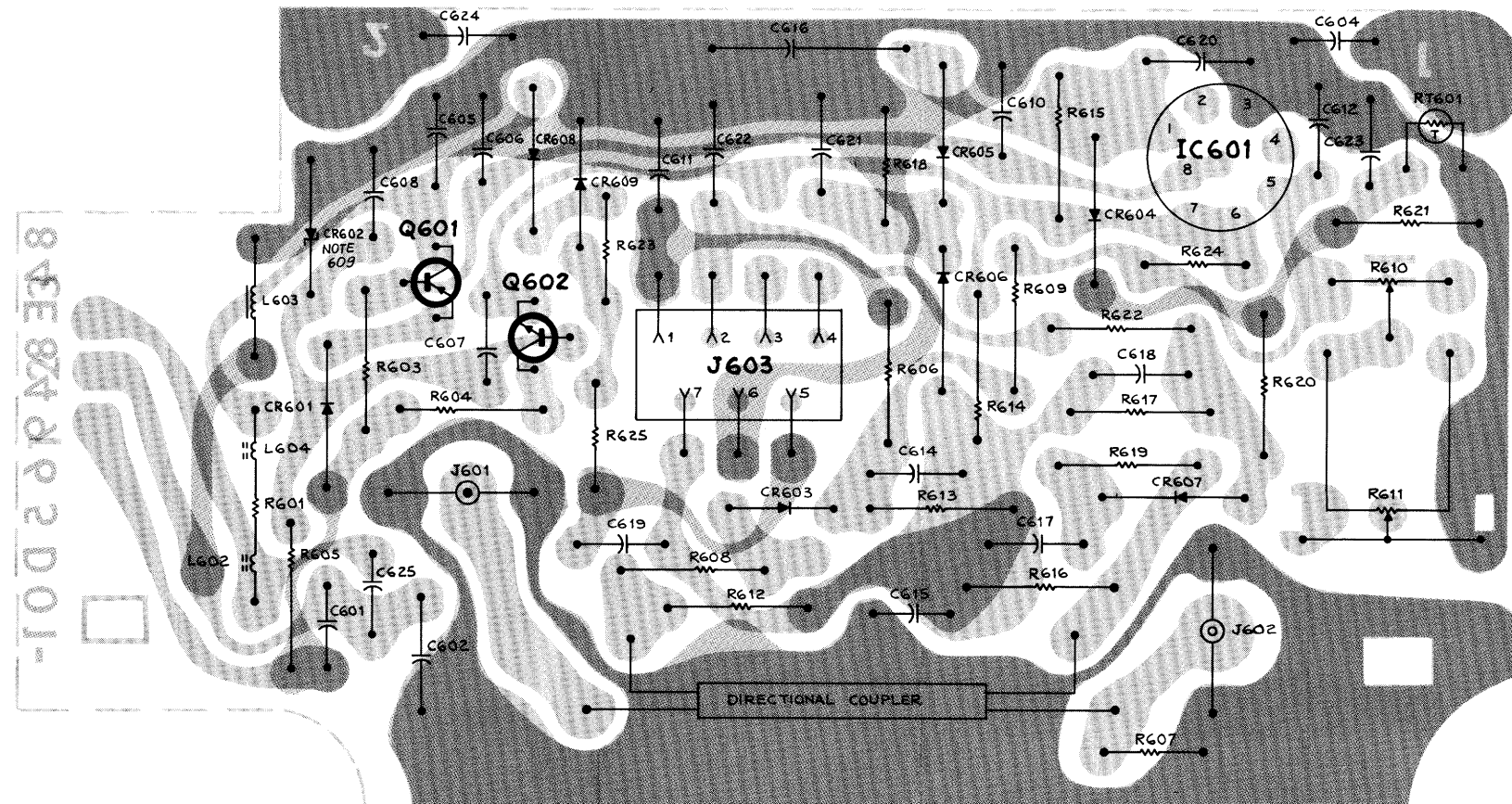

SHOWN FROM SOLDER SIDE

COMPONENT SIDE ● 8D-CEPS-16 811-0  
SOLDER SIDE ● 8D-CEPS-16 612-0  
● 0L-CEPS-16 813-C

## electrical parts list

TLD5960A Power Control Board (High Power) PL-8266-A

| REFERENCE SYMBOL        | MOTOROLA PART NO. | DESCRIPTION   |
|-------------------------|-------------------|---|
| C601, 602, 604 thru 608 | 21-83596E10       | capacitor, fixed: ± 20% 500 V; unless otherwise stated 220 pF       |
| C610                    | 21-82372C04       | .05 uF + 80-20%; 25 V   |
| C611, 612, 614, 615     | 21-83596E10       | 220 pF; 500 V   |
| C616                    | 23-83214C04       | 1.0 uF ± 20%; 15 V  |
| C617                    | 21-82133G53       | 5 pF ± 0.5 pF; 500 V; NPO   |
| C618 thru 624           | 21-83596E10       | 220 pF ± 20%; 500 V   |
| C625                    | 21-82187E14       | .001 uF ± 10%; 100 V  |
| CR601                   | 48-83654H01       | semiconductor device, diode: silicon                                |
| CR602                   | 48-83696E04       | Zener (9.1 V)   |
| CR603                   | 48-84616A01       | hybrid assembly   |
| CR604, 605, 606         | 48-82392B11       | silicon   |
| CR607                   | 48-84616A01       | silicon   |
| CR608                   | 48-82392B03       | silicon   |
| CR609                   | 48-82392B18       | silicon   |
| E601                    | 58-84685B01       | coupler, line: dual   |
| IC601                   | 51-84320A02       | integrated circuit: M2002   |
| J601                    | 28-84227B02       | connector, receptacle: male; single-contact                         |
| J602                    | 9-84231B02        | female; single-contact  |
| J603                    | 9-84207B01        | female; 7-contact   |
| L602                    | 76-83960B01       | coil, rf: ferrite bead  |
| L603                    | 24-83961B01       | choke   |
| L604                    | 76-83960B01       | ferrite bead  |
| Q601                    | 48-869641         | transistor: PNP; type M9641   |
| Q602                    | 48-869570         | NPN; type M9570   |
| R601                    | 17-82291B21       | resistor, fixed ± 10%; 1/4 W; unless otherwise stated 100 ± 5%; 3 W |
| R603                    | 6-124C49          | 1k  |
| R604                    | 6-124C19          | 56  |
| R605                    | 6-124A45          | 680 ± 5%  |
| R606                    | 6-124A83          | 27k ± 5%  |
| R607                    | 6-124C97          | 100k  |
| R608                    | 6-124A45          | 680 ± 5%  |
| R609                    | 6-124A63          | 3.9k ± 5%   |
| R610                    | 18-83083G26       | variable; 50k   |
| R611                    | 18-83083G20       | variable; 50k   |
| R612                    | 6-124A21          | 1k ± 5%   |
| R613                    | 6-124A49          | 1k ± 5%   |
| R614                    | 6-124A39          | 390 ± 5%  |
| R615                    | 6-124C75          | 12k   |
| R616                    | 6-124A21          | 68 ± 5%   |
| R617                    | 6-124A57          | 2.2k ± 5%   |
| R618                    | 6-124A45          | 680 ± 5%  |
| R619                    | 6-124A27          | 120 ± 5%  |
| R620                    | 6-124C49          | 1k  |
| R621                    | 6-124A89          | 47k   |
| R622                    | 6-124A89          | 47k ± 5%  |
| R623                    | 6-185A93          | 68k ± 5%; 1/8 W   |
| R624                    | 6-185B99          | 47k; 1/8  |
| R625                    | 6-185A73          | 10k ± 5%; 1/8 W   |

| mechanical parts |                                     |  |
|------------------|-------------------------------------|--|
| 3-138162         | SCREW, tapping; 4-40 x 3/8"; 4 used |  |
| 42-84284B01      | RETAINER; 4 used                    |  |
| 55-84300B04      | HANDLE                              |  |

Mechanical Parts List PL-854-D

| CODE            | MOTOROLA PART NO.                                     | DESCRIPTION                  |
|-----------------|---|------------------------------|
| 1               | 42-84284B01   | RETAINER; 4 used             |
| 2               | 3-139506  | SCREW, tapping; 4-40 x 5/16" |
| 3               | 29-84028H01   | TERMINAL, male; 3 used       |
| 4               | 42-84678B01   | CLIP, component              |
| non-coded items |   |                              |
| 55-84300B04     | HANDLE, plastic                                       |                              |
| 1-80797B34      | CABLE ASSEMBLY (TLD8610AV & TLD8620AV only) includes: |                              |
| 42-10217A02     | STRAP, tie  |                              |

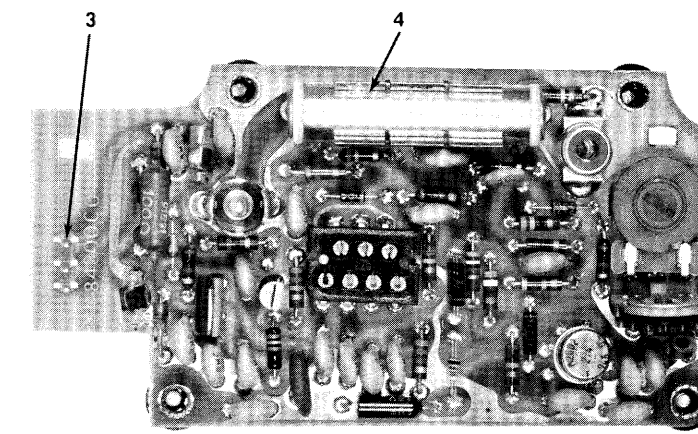
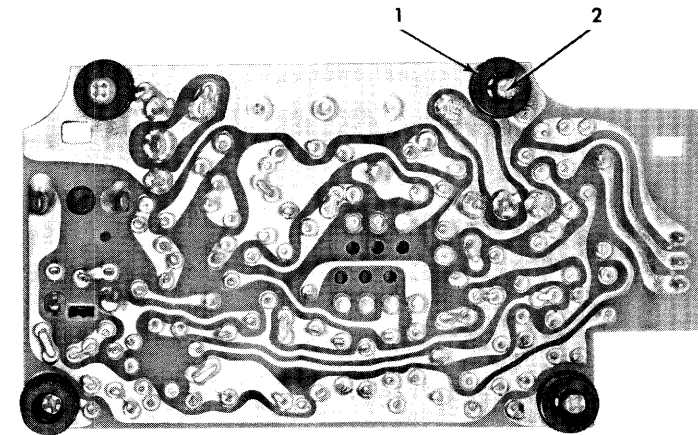

BEPS-6542-0

# TLD5950A SERIES POWER AMPLIFIER BOARD

## DIAGRAM & PARTS LIST

PA Component Values

| Ref  | 136-150.8 MHz | 150.8-162 MHz | 162-174 MHz |
|------|---------------|---------------|-------------|
| C501 | 4-40          | 1.5-18        | 1.5-18      |
| C502 | 2.4-27        | 2-19.3        | 2-19.3      |
| C505 | 62            | 49            | 62          |
| C506 | 62            | 51            | 34          |
| C508 | 160           | 130           | 130         |
| C509 | 15            | 15            | 10          |
| C510 | 175           | 51            | 39          |
| C511 | 62            | 51            | 39          |
| C513 | 160           | 130           | 130         |
| C515 | —             | 3.3 uF        | 3.3 uF      |
| C518 | 49            | 60            | 49          |
| C519 | 49            | 60            | 43          |
| C520 | 30            | 25            | 20          |
| C521 | 62            | 43            | 43          |
| C522 | 56            | 39            | 51          |
| C523 | 80            | 100           | 120         |
| C524 | —             | .01 uF        | .05 uF      |
| C526 | —             | .01 uF        | .05 uF      |
| C527 | 43            | 30            | 24          |
| C528 | 75            | 75            | 80          |
| C529 | 60            | 51            | 51          |
| C531 | 43            | 30            | 24          |
| C532 | 75            | 75            | 80          |
| C533 | 62            | 60            | 68          |
| C536 | 220           | 390           | —           |
| C537 | 130           | 150           | 100         |
| C538 | 130           | 150           | 120         |
| C541 | 220           | 130           | 130         |
| C542 | 130           | 150           | 100         |
| C543 | 120           | 130           | 100         |
| C546 | 1200          | 1200          | 1200        |
| C547 | 1200          | 1200          | 1200        |
| C548 | 160           | 130           | 130         |
| C551 | 160           | 130           | 130         |
| C552 | 15 uF         | 100 uF        | 100 uF      |
| C556 | 30            | 10            | 6           |
| C557 | —             | —             | 4.7 uF      |
| C571 | —             | .068 uF       | .068 uF     |
| L503 | 7-84400B03    | 1-1/2 turns   | 1-1/2 turns |
| L504 | 1 turn        | 1 turn        | 85          |
| L506 | .039 uH       | .039 uH       | 290 nH      |
| L507 | 2-1/2 turns   | 4-1/2 turns   | 4-1/2 turns |
| L508 | 2-1/2 turns   | 4-1/2 turns   | 4-1/2 turns |
| L509 | 0.29 uH       | .039 uH       | 290 nH      |
| L510 | 0.29 uH       | .039 uH       | 290 nH      |
| L511 | 4-1/2 turns   | 4-1/2 turns   | 0.29 nH     |
| L512 | 4-1/2 turns   | 4-1/2 turns   | 0.29 nH     |
| R501 | 100k          | 150k          | 150k        |
| R502 | 10            | 10            | 49          |
| R511 | 2.7           | 2.7           | —           |
| R514 | —             | 100           | 51          |
| R515 | —             | 100           | 51          |
| R528 | —             | —             | 2.7         |
| T503 | 25-84859L01   | 25-84854L02   | 24-82060L01 |
| T504 | 25-84859L02   | 25-84854L02   | 24-82060L01 |
| T505 | 25-84860L01   | 25-84860L01   | 25-82061L01 |
| T506 | 25-84860L01   | 25-84860L01   | 25-82061L01 |

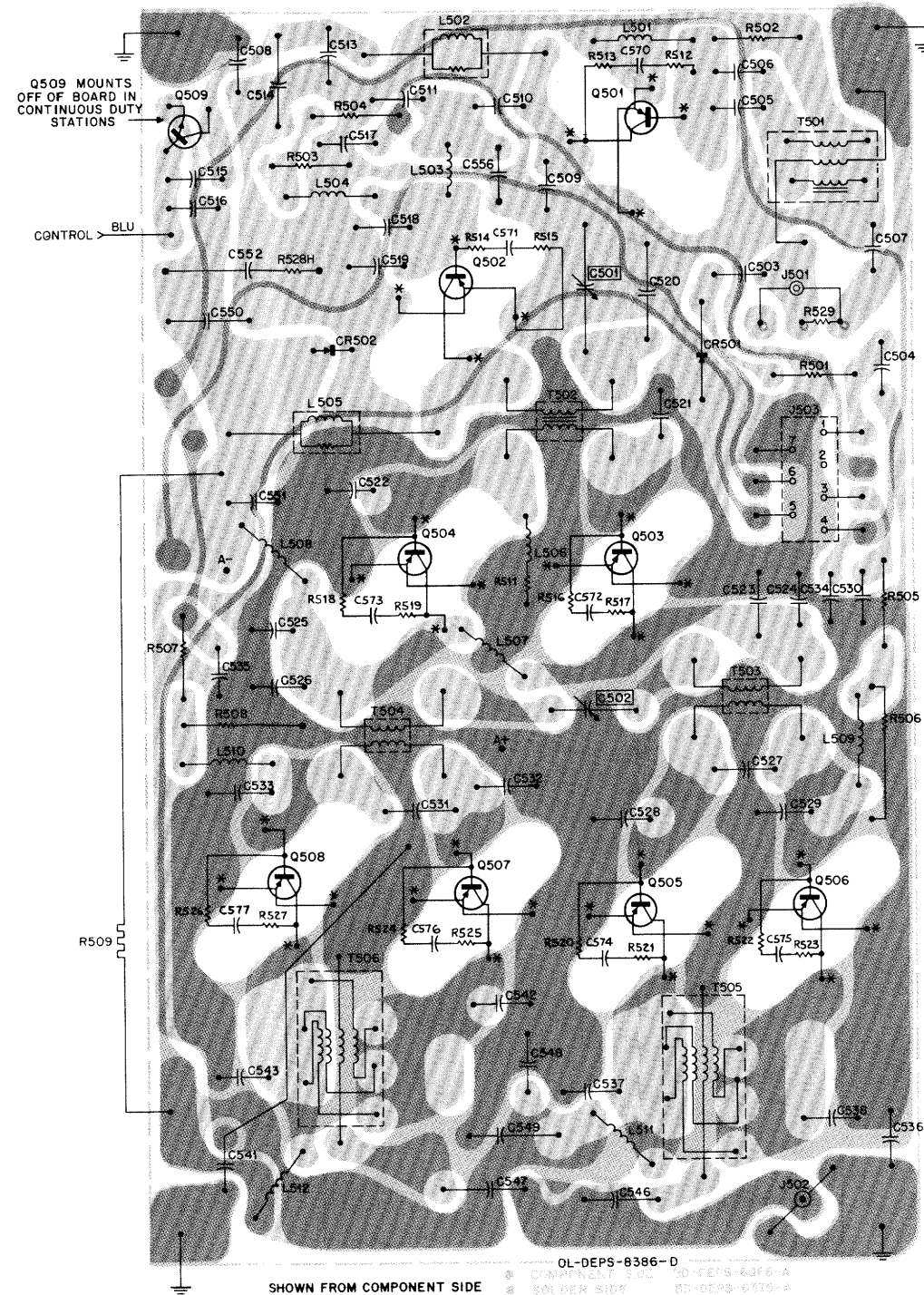
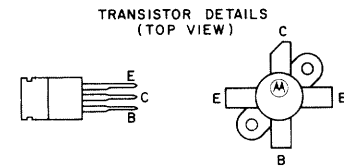

\* THESE TRANSISTOR LEADS ARE CONNECTED TO ONLY THE COMPONENT SIDE OF THE BOARD

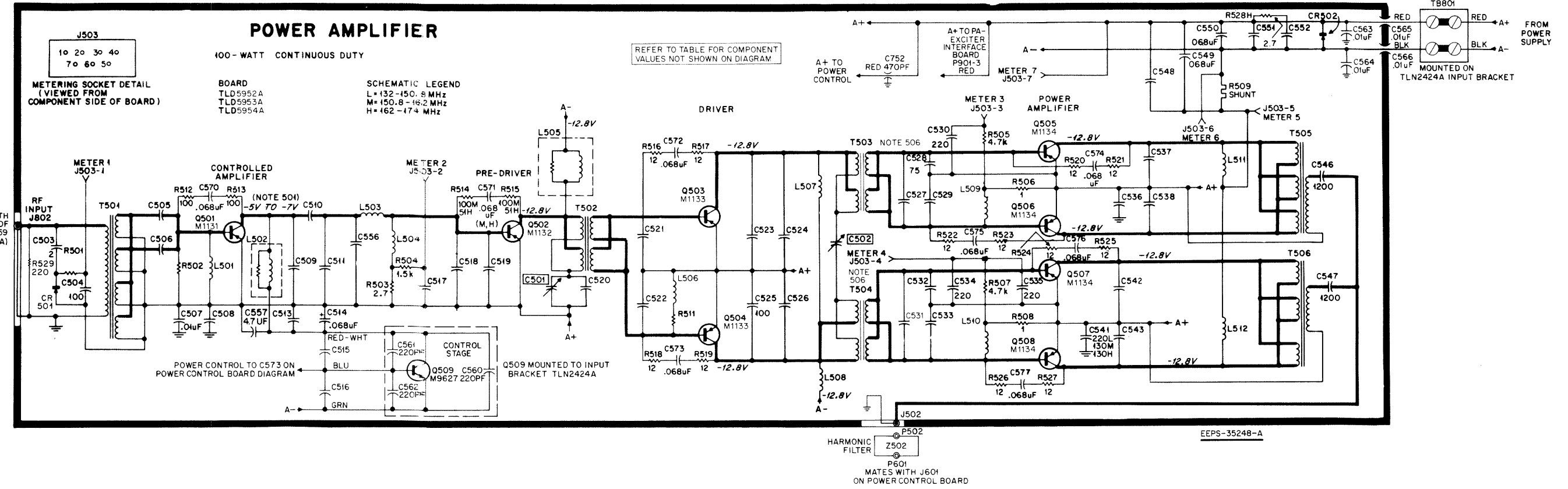

NOTES

- 501. Voltages dependent upon amount of cutback from power control board.
- 502. Voltages measured in respect to A+ unless otherwise specified.
- 503. Unless otherwise specified.
- Capacitor values are in picofarads.
- 506. For frequency range 162-174 MHz air-core transformers.

PARTS LISTS SHOWN ON BACK OF THIS DIAGRAM

parts list

TRN5577A PA Casting and Hardware Kit PL-8218-A

| REFERENCE SYMBOL        | MOTOROLA PART NO.          | DESCRIPTION   |
|-------------------------|----------------------------|---|
| C563, 564<br>C780       | 21-84211B02<br>23-83214C20 | <b>capacitor, fixed:</b><br>.01 uF + 100-0%; 250 V<br>10 uF ± 20%; 20 V |
| L780                    | 24-80900A61                | <b>coil, rf:</b><br>choke; 0.62 mH                                      |
| R780                    | 6-124B67                   | <b>resistor, fixed:</b><br>8.2 ± 5%; 1/4 W                              |
| <b>mechanical parts</b> |                            |   |
|                         | 2-119913                   | NUT, 8-32 x 11/32 x 1/8"; 2 used  |
|                         | 3-131195                   | SCREW, machine; 6-32 x 3/8"; 18 used                                    |
|                         | 3-134184                   | SCREW, tapping; 4-40 x 5/16"; 8 used                                    |
|                         | 3-134185                   | SCREW, tapping; 6-32 x 1/4"; 4 used                                     |
|                         | 3-136930                   | SCREW, tapping; 4-40 x 1/2"; 4 used                                     |
|                         | 3-83677N04                 | SCREW, capture; 4 used  |
|                         | 4-7557                     | WASHER, flat, 0.172 x 0.375 x .033; 6 used                              |
|                         | 4-801846                   | WASHER, insulator; 3/8"; 2 used   |
|                         | 7-84347N01                 | BRACKET, mounting; (RH)   |
|                         | 7-84347N02                 | BRACKET, mounting (LH)  |
|                         | 15-84403D01                | COVER, power control  |
|                         | 26-84404D03                | HEAT EXCHANGE, PA   |
|                         | 31-131744                  | TERMINAL, strip; 2 insulated #2 mounting                                |
|                         | 42-84328E01                | CLIP  |
|                         | 66-106515                  | WRENCH, Allen   |

TRN5586A PA Hardware PL-8219-A

| REFERENCE SYMBOL        | MOTOROLA PART NO. | DESCRIPTION   |
|-------------------------|-------------------|---|
| C751, 752, 753          | 21-821474         | <b>capacitor, fixed: ± 20%; 500 V:</b><br>470 pF; (feed-thru) |
| Q501                    | 48-84411L31       | <b>transistor: (see note)</b><br>PNP; type M1131              |
| Q502                    | 48-84411L32       | PNP; type M1132   |
| Q503, 504               | 48-84411L33       | PNP; type M1133   |
| Q500 thru 508           | 48-84411L34       | PNP; M1134  |
| <b>mechanical parts</b> |                   |   |
|                         | 3-114406          | SCREW, cap; 4-40 x 5/16"; 20 used                             |
|                         | 3-134309          | SCREW, tapping; 4-40 x 5/16"; 3 used                          |
|                         | 14-84290B02       | INSULATOR   |
|                         | 26-84911L01       | SHIELD, PA  |
|                         | 42-10217A02       | STRAP, tie: .091 x 3.62 nylon; 3 used                         |
|                         | 54-84429N01       | LABEL, PA   |
|                         | 4-83755H01        | WASHER, solder; 7 used  |
|                         | 7-82379M01        | BRACKET   |
|                         | 9-84234E10        | CONNECTOR, receptacle; 3 used                                 |

PA Output (Harmonic) Filter PL-1722-O

| REFERENCE SYMBOL | MOTOROLA PART NO. | DESCRIPTION                                   |
|------------------|-------------------|---|
| Z502L            | TFD6101A          | <b>filter, rf; low pass:</b><br>132-150.8 MHz |
| Z502M, 502H      | TFD6102A          | 150.8-174 MHz                                 |

LEGEND:  
L = 132-150.8 MHz  
M = 150.8-162 MHz  
H = 162-174 MHz

TLD5952A PA Board (132-150.8 MHz)  
TLD5953A PA Board (150.8-162 MHz)  
TLD5954A PA Board (162-174 MHz) PL-6100-B

| REFERENCE SYMBOL | MOTOROLA PART NO. | DESCRIPTION  |
|------------------|-------------------|--|
| C501L            | 20-83201B09       | <b>capacitor, fixed: pF; ± 5%; 500 V:</b><br>unless otherwise stated |
| C501M, 501H      | 20-83201B07       | variable; 4-40   |
| C502L            | 19-83491E08       | variable; 1.5-18   |
| C502M, 502H      | 19-83491E07       | variable; 2.4-27 (voltage not stated)                                |
| C503             | 21-83406D52       | variable; 2-19.3 (voltage not stated)                                |
| C504             | 21-84494B04       | 2  |
| C505L            | 21-84494B02       | 100  |
| C505M            | 21-84494B25       | 62   |
| C505H, 506L      | 21-84494B02       | 49   |
| C506M            | 21-84494B01       | 62   |
| C506H            | 21-84494B30       | 51   |
| C507             | 21-82428B59       | 34   |
| C508L            | 21-84494B51       | .01 uF + 80-20%; 200 V   |
| C508M, 508H      | 21-84494B26       | 160  |
| C509L, 509M      | 21-84494B38       | 130  |
| C509H            | 21-84494B29       | 15   |
| C510L            | 21-84494B09       | 10   |
| C510M            | 21-84494B01       | 175  |
| C510H            | 21-84494B24       | 51   |
| C511L            | 21-84494B02       | 39   |
| C511M            | 21-83366K20       | 62   |
| C511H            | 21-83366K20       | 51   |
| C513L            | 21-84494B51       | 39   |
| C513M, 513H      | 21-84494B26       | 160  |
| C514, 549, 550   | 8-83813H05        | 130  |
| C515L            |                   | .068 uF ± 10%; 100 V   |
| C515M            | 23-11019A16       | NOT USED   |
| C516M            | 23-83908L01       | 4.7 uF; 35 V   |
| C516L, 516H      | 23-83214C10       | 100 uF; 25 V   |
| C517             | 21-83596E10       | 47 uF ± 20%; 6 V   |
| C518L            | 21-84494B25       | 220  |
| C518M            | 21-84494B35       | 49   |
| C518H, 519L      | 21-84494B25       | 60   |
| C519M            | 21-84494B35       | 49   |
| C519H            | 21-84494B28       | 60   |
| C520L            | 21-84936A06       | 43   |
| C520M            | 21-83034P04       | 30 ± 1.5 pF; 2000 V  |
| C520H            | 21-84936A03       | 25; 2000 V   |
| C521L            | 21-84494B02       | 20; 2000 V   |
| C521M, 521H      | 21-84494B28       | 62   |
| C522L            | 21-84494B45       | 43   |
| C522M            | 21-84494B24       | 56   |
| C522H            | 21-84494B01       | 39   |
| C523L            | 21-83366K12       | 51   |
| C523M            | 21-83366K14       | 80; 250 V  |
| C523H            | 21-83366K14       | 100; 250 V   |
| C524L, 526L      |                   | 120; 250 V   |
| C524M, 526M      | 21-82428B59       | NOT USED   |
| C525             | 21-83366K13       | .01 uF + 80-20%; 200 V   |
| C527L            | 21-83366K19       | .05 uF + 80-20%; 25 V  |
| C527M            | 21-83366K18       | 100; 250 V   |
| C527H            | 21-83366K17       | 43   |
| C528L, 528M      | 21-83366K24       | 30   |
| C528H            | 21-83366K25       | 24   |
| C529L            | 21-83366K21       | 75   |
| C529M, 529H      | 21-83366K20       | 80   |
| C530             | 21-83596E10       | 60   |
| C531L            | 21-83366K19       | 51   |
| C531M            | 21-83366K18       | 220  |
| C531H            | 21-83366K17       | 43   |
| C532L, 532M      | 21-83366K24       | 30   |
| C532H            | 21-83366K25       | 75   |
| C533L            | 21-83366K22       | 80   |
| C533M            | 21-83366K21       | 62   |
| C533H            | 21-83366K23       | 60   |
| C534, 535        | 21-83366K10       | 68   |
| C536L            | 21-84494B12       | 220  |
| C536M            | 21-84494B18       | 220  |
| C536H            |                   | 390  |
| C537L            | 21-83366K15       | NOT USED   |
| C537M            | 21-83366K16       | 130; 250 V   |
| C537H            | 21-83366K13       | 150; 250 V   |
| C538L            | 21-83366K15       | 100; 250 V   |
| C538M            | 21-83366K16       | 130; 250 V   |
| C538H            | 21-83366K14       | 150; 250 V   |
| C541L            | 21-84494B12       | 120; 250 V   |
| C541M, 541H      | 21-84494B26       | 220  |
| C542L            | 21-83366K15       | 130  |
| C542M            | 21-83366K16       | 130; 250 V   |
|                  |                   | 150; 250 V   |

| REFERENCE SYMBOL | MOTOROLA PART NO. | DESCRIPTION  |
|------------------|-------------------|--|
| C542H            | 21-83366K13       | 100; 250 V   |
| C543L            | 21-83366K14       | 120; 250 V   |
| C543M            | 21-83366K15       | 130; 250 V   |
| C543H            | 21-83366K13       | 100; 250 V   |
| C546, 547        | 21-84426B36       | 1200   |
| C548L            | 21-84494B51       | 160  |
| C548M, 548H      | 21-84494B26       | 130  |
| C551L            | 21-84494B51       | 160  |
| C551M, 551H      | 21-84494B26       | 130  |
| C552L            | 23-83214C02       | 15 uF ± 20%; 25 V  |
| C552M            | 23-84669A19       | 100 uF + 150-20%; 20 V   |
| C552H            | 23-82783B04       | 100 uF ± 20%; 25 V   |
| C556L            | 21-84494B33       | 30   |
| C556M            | 21-84494B29       | 10   |
| C556H            | 21-84494B74       | 6  |
| C557H            | 23-82783B25       | 4.7 uF ± 10%; 25 V   |
| CR501            | 4882139G01        | <b>semiconductor device, diode: (see note)</b><br>germanium      |
| CR502            | 48-82525G01       | silicon  |
| P501, 502        | 28-84227B01       | <b>connector, receptacle; female:</b><br>coaxial, miniature type |
| J503             | 9-84207B01        | 7-contact  |
| L501             | 24-83961B01       | <b>coil, rf:</b><br>choke; 3 turns; coded BRN                    |
| L502             | 24-84392B03       | choke; 6 turns   |
| L503L            | 7-84400B03        | inductor "bracket"   |
| L503M, 503H      | 24-83884G03       | 1-1/2 turns  |
| L504L, 504M      | 24-83961B03       | choke; 1 turns; coded WHT  |
| L504H            | 24-82723H18       | choke; 85 nH   |
| L505             | 24-84392B02       | choke; 4 turns   |
| L506L, 506M      | 24-82723H02       | choke; 39 nH   |
| L506H            | 24-82723H20       | choke; 290 nH  |
| L507L, 508L      | 24-8547G10        | choke; 2-1/2 turns   |
| L507M, 507H,     | 24-84393B02       | choke; 4-1/2 turns   |
| 508M, 507H       |                   |  |
| L509L, 510L      | 24-82723H04       | choke; 0.29 uH   |
| L509M, 510M      | 24-82723H02       | choke; 39 nH   |
| L509H, 510H      | 24-82723H20       | choke; 290 nH  |
| L511L, 511M      | 24-84393B02       | 4-1/2 turns  |
| L511H            | 24-82723H04       | choke; 0.29 uH   |
| L512L, 512M      | 24-84393B02       | 4-1/2 turns  |
| L512H            | 24-82723H04       | choke; 0.29 uH   |
| E101M, 102M      | 76-83960B01       | ferrite bead   |
| R501L            | 6-124C97          | <b>resistor, fixed: ± 10%; 1/4 W:</b><br>unless otherwise stated |
| R501M, 501H      | 6-124D02          | 100k   |
| R502L, 502M      | 6-124A01          | 150k   |
| R502H            | 6-124C17          | 10 ± 5%  |
| R503             | 6-124B55          | 47   |
| R504             | 6-124C53          | 2.7 ± 5%   |
| R505, 507        | 6-124C65          | 1.5k   |
| R506, 508        | 6-125D70          | 4.7k   |
| R509             | 6-84232B01        | 1; 1/2 W   |
| R511L, 511M      | 6-124D55          | (meter shunt)  |
| R528H            | 6-124D55          | 2.7 ± 5%   |
| R529             | 6-11009A33        | 220 ± 5%   |
| T501             | 25-84396B01       | <b>transformer, rf:</b><br>pri: 5 turns                          |
| T502             | 25-84397B01       | sec: 4 windings, 1 turn each                                     |
| T503L            | 25-84859L01       | pri: 2 windings, 1-3/4 turns each                                |
|                  |                   | sec: 2 windings, 1-3/4 turns each                                |
|                  |                   | pri: 2 windings, 2-3/4 turns each                                |
|                  |                   | sec: 2 windings, 2-3/4 turns each                                |
|                  |                   | NOTE: ("left hand" windings)                                     |
| T503M            | 25-84854L01       | pri: 3-3/4 turns   |
|                  |                   | sec: 3-3/4 turns   |
| T503H            | 24-82060L01       | pri: 2 windings, 2 turns each                                    |
|                  |                   | sec: 2 windings, 2 turns each                                    |
| T504L            | 25-84859L02       | pri: 2 windings, 2-3/4 turns each                                |
|                  |                   | sec: 2 windings, 2-3/4 turns each                                |
|                  |                   | NOTE: ("right hand" windings)                                    |
| T504M            | 25-84854L02       | pri: 3-3/4 turns   |
|                  |                   | sec: 3-3/4 turns   |
| T504H            | 24-82060L01       | pri: 2 windings, 2 turns each                                    |
|                  |                   | sec: 2 windings, 2 turns each                                    |
| T505L, 505M      | 25-84860L01       | pri: 3 windings, 1-1/2 turns each                                |
|                  |                   | sec: 6 turns   |
| T505H            | 25-84861L01       | pri: 3 windings, 1-1/2 turns each                                |
|                  |                   | sec: 5 turns   |
| T506L, 506M      | 25-84860L01       | pri: 3 windings, 1-1/2 turns each                                |
|                  |                   | sec: 6 turns   |
| T506H            | 25-84861L01       | pri: 3 windings, 1-1/2 turns each                                |
|                  |                   | sec: 5 turns   |

note: For optimum performance, diodes, transistors, and integrated circuits must be ordered by Motorola part numbers.

TRN8069A Resistor-Capacitor Network Kit (132-150.8 MHz)  
TRN6445A Resistor-Capacitor Network Kit (150.8-162 MHz)  
TLD5502A Resistor-Capacitor Network Kit (162-174 MHz) PL-5396-A

| REFERENCE SYMBOL      | MOTOROLA PART NO. | DESCRIPTION   |
|-----------------------|-------------------|---|
| C570, 572 thru<br>577 | 8-83813H05        | <b>capacitor, fixed; ± 10%; 100 V:</b><br>unless otherwise stated |
| C571L                 |                   | .068 uF   |
| C571M, 571H           | 8-83813H05        | NOT USED  |
|                       |                   | .068 uF   |
| R512, 513             | 6-125C25          | <b>resistor, fixed: ± 10%; 1/2 W:</b><br>unless otherwise stated  |
| R514L, 515L           |                   | 100   |
| R514M, 515M           | 6-125C25          | NOT USED  |
| R514H, 515H           | 6-125A18          | 100   |
| R516 thru 527         | 6-125C03          | 51 ± 5%; 1/2 W  |
|                       |                   | 12  |

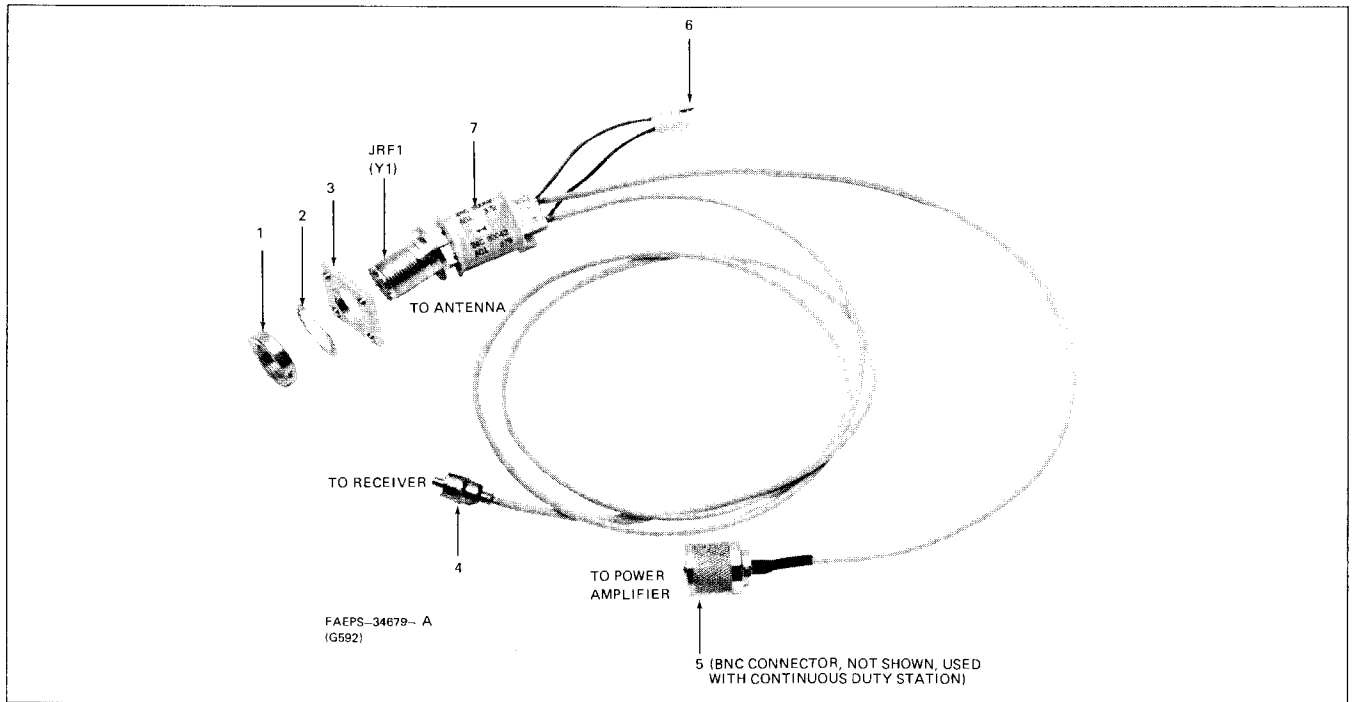

**ANTENNA SWITCH REPLACEMENT**

1. Remove the card cage per manual instructions in the maintenance section.
2. Note the positions of the tie wraps and cable clamps, and pay attention to cable routing.
3. Remove the appropriate cable clamps, and clip the necessary tie wraps.
4. Remove the antenna switch:
  - 4.1 Unfasten the receiver antenna connector from the card cage chassis (2 screws).
  - 4.2 Disconnect the rf connector from the PA output
  - 4.3 Unfasten the 2 pin molex connector.

- 4.4 Remove the antenna switches spanner nut from the junction box.
5. Installation is the reverse of the above. Remember to fasten the cables with new tie wraps.

**parts list**

TRN9168A Antenna Switch  
TRN5864A Antenna Switch PL-8685-A

| REFERENCE SYMBOL | MOTOROLA PART NO.             | DESCRIPTION   |
|------------------|-------------------------------|---|
| 1                | 2-80006A01                    | NUT, spanner  |
| 2                | 4-114522                      | LOCKWASHER, 5/8"  |
| 3                | 43-82895N01                   | SPACER  |
| 4                | 28-82875N01<br>or 28-82331G01 | CONNECTOR, receiver (TRN5864A)<br>CONNECTOR, preamp (TRN9618A)                |
| 5                | 28-84579F01<br>28-83099K01    | CONNECTOR, PA (P03) Intermittent Duty<br>CONNECTOR, PA (P803) Continuous Duty |
| 6                |                               | J801 consists of 15-84861K02 Housing<br>29-84706E05 TERMINALS                 |
| 7                |                               | ANTENNA SWITCH, non-serviceable   |

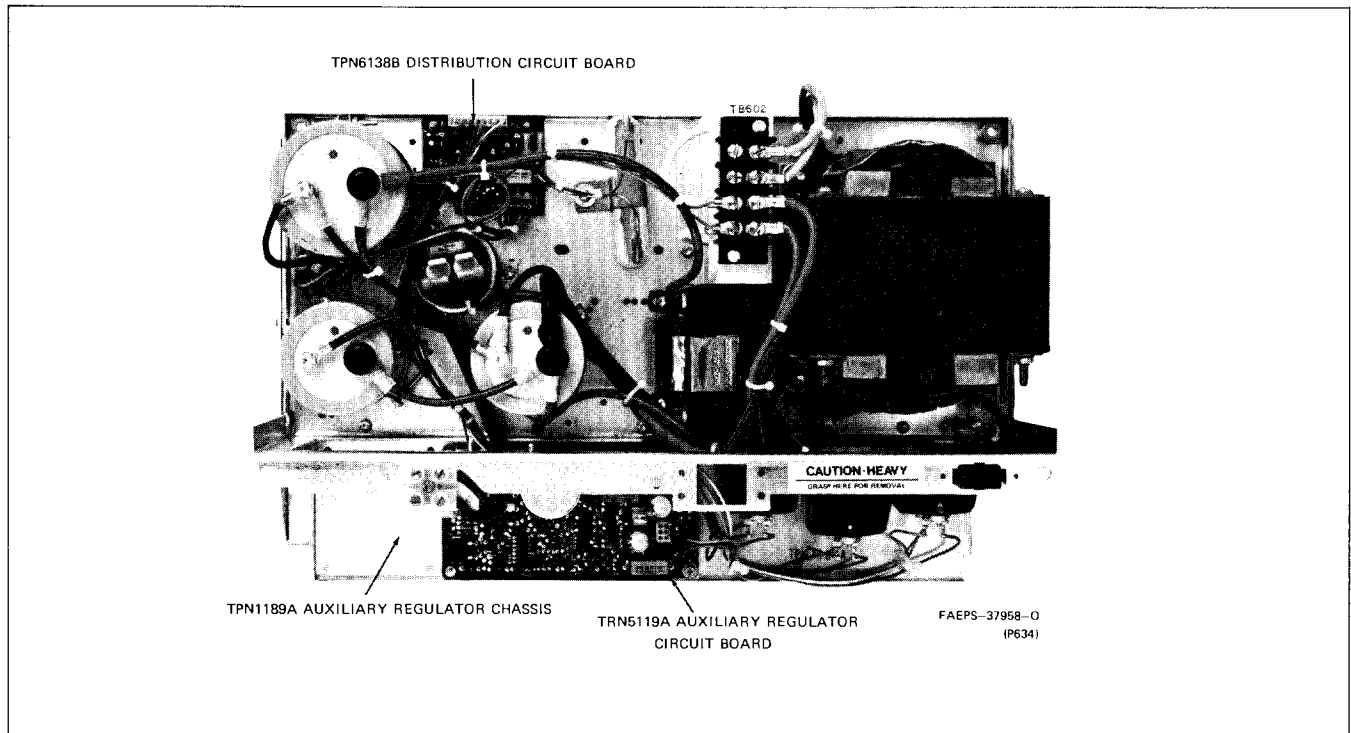

*Figure 1. Model TPN1191A Standard Power Supply*

## 1. DESCRIPTION

(Refer to Figure 1)

**1.1** Model TPN1191A Standard Power Supply is a high efficiency, solid state, power source for operation of base and repeater radio stations. The power supply consists of three main sections: transformer/rectifier/filter, distribution board, and auxiliary regulator board. Refer to Table 1 for the power supply model complement.

**1.2** The transformer has a primary winding, a high current secondary winding, and a resonant secondary winding. Under normal operations, the current in the resonant winding causes the transformer core to satu-

rate, limiting the transformer output voltage. Rectifying and filtering the transformer output produces a stable direct current output.

**1.3** The distribution board consists of four power supply fuses and circuitry for overvoltage protection. Transistorized circuitry senses a high dc voltage and adds loading for voltage reduction.

**1.4** The auxiliary regulator board consists of two current limited linear series pass regulators. These regulators are set for 9.4 V and 13.9 V. The 9.4 V regulator draws power from the main ferroresonant supply output. The 13.9 V regulator draws full-wave rectified power directly from the ferroresonant transformer.

**1.5** The features of this power supply include short circuit protection which is inherent in the ferroresonant power transformer, and overvoltage protection. Refer to Table 2 for performance specifications.

*Table 1. Model Complement for TPN1191A Standard Power Supply*

| Kit      | Sub-Kit  | Description                       |
|----------|----------|-----------------------------------|
| TPN1189A |          | Auxiliary Regulator Chassis       |
|          | TRN5119A | Auxiliary Regulator Circuit Board |
|          | TRN5297A | Hardware Kit                      |
|          | TRN5299A | Chassis Kit                       |
| TPN6138B |          | Distribution Circuit Board        |
| TRN5335A |          | Hardware, Interconnect            |
| TRN5336A |          | Hardware, 500 W                   |
| TRN5452A |          | Hardware, Miscellaneous           |

## 2. THEORY OF OPERATION

### 2.1 TRN5336A STANDARD POWER SUPPLY

The TRN5336A Power Supply performs the conversion of ac line voltage to the dc voltages required by the radio. The supply consists of rectification, filtering, and regulation.

#### 2.1.1 Rectification and Filtering

The secondary voltage of transformer T601 is rectified by CR601 and CR602. Ground connection for the diodes is provided through the heat sink to chassis. Output filtering is provided by the network of C602, C603, L601, and C604.

#### 2.1.2 Regulation

Line and load regulation is provided by the ferroresonant action in the secondary resonant winding of the power transformer T601. The high voltage winding resonates with C601, causing the secondary to saturate and restrict the secondary output voltage.

### 2.2 TPN6138B DISTRIBUTION BOARD

The TPN6138B Distribution Board provides overcurrent and overvoltage protection for the power supply. Refer to the functional and schematic diagrams for circuit details. Secondary voltage fusing is provided by F602 thru F605. Overvoltage protection is provided by a surge protection circuit consisting of Q601 thru Q604. A surge in excess of 18 V causes VR601 to conduct. Forward bias current through R602 and base-emitter junction of Q604, turns on Q604. The other transistors turn on, and the chassis mounted R601 acts as a pull-down load for the line voltage surge.

*Table 2. Performance Specifications*

|                       |   |
|-----------------------|---|
| Operating Temperature | -30° to +80°C                             |
| Input Voltage         | 96-132 V; 60 Hz                           |
| Line Current*         | 8A max. at full rated power supply output |

### HIGH CURRENT OUTPUT

|                             |  |
|-----------------------------|--|
| Steady State Output Voltage | 13.1 to 16.3 V dc (36A to 2A)                            |
| Output Current              | 30.4A at 14.1 V  |
| Load Transient              | Shall not drop below 11.5 V for a 2A to 36A transient    |
| Output Ripple               | 50 mV p-p 25°C to +80°C<br>Derate to 100 mV p-p at -30°C |

### 9.4 V OUTPUT

|                       |   |
|-----------------------|---|
| Output Voltage        | 9.4 V dc set nominal (9.1-9.7 adjustable)                   |
| Output Ripple         | Less than 10 mV rms when installed in station               |
| Line Regulation       | Shall not change more than 50 mV over input range           |
| Load Regulation       | Shall not change more than 150 mV from no load to full load |
| Max. Output Current   | 1.1A at +80°C   |
| Current Limit         | 2.3A typ at 25°C  |
| Short Circuit Current | 0.77 max @25°C  |

### 14 V OUTPUT

|                       |   |
|-----------------------|---|
| Output Voltage        | 13.9 set nominal (13.5-14.1 adjustable)                     |
| Output Ripple         | Less than 10 mVrms when installed in station                |
| Line Regulation       | Shall not change more than 25 mV over input voltage         |
| Load Regulation       | Shall not change more than 175 mV from no load to full load |
| Max. Output Current   | 1.16A at +80°C  |
| Current Limit         | 2.3A typ at 25°C  |
| Short Circuit Current | 0.77A max. @25°C  |

\* When calculating primary power requirements do not use Line Current to calculate dissipated power. Use a power meter with provisions for nonunity Power Factor.

*SPECIFICATIONS SUBJECT TO CHANGE WITHOUT NOTICE*

### 2.3 TRN5119A AUXILIARY REGULATOR BOARD

The TRN5119A Auxiliary Regulator Board provides regulated 9.4 V and 14 V for the radio. The board circuitry consists of a reference voltage, 9.4 V and 14 V regulators, temperature compensated overcurrent amplifier, and a local control inhibit inverter.

#### 2.3.1 Reference Voltage

The operational amplifiers on the circuit board requires a stable reference voltage. This reference voltage is pro-

duced in two stages of circuitry. The first stage consists of VR4 and R40 which are connected to J1-1 and main 13.8 V. Diode VR4 regulates at 9.6 V. The second stage which operates from this 9.6 V is temperature compensated and consists of VR1, CR2, and R39. The resultant 6.5 V reference is feed to each of the operational amplifiers.

### 2.3.2 9.4 V Regulator

**2.3.2.1** The 9.4 V regulator is a series pass type circuit using a PNP transistor (Q6). A PNP type transistor can provide voltage regulation with as little as 0.7 V differential between collector and emitter. This means that the input voltage can go as low as 10.4 V, and the circuitry will still maintain voltage regulation. The voltage regulator circuitry provides output voltage adjustment, correction for changes of input voltage and load and overcurrent protection.

**2.3.2.2** The 9.4 V regulator output voltage (J5-6) is set by the 9.4 V VOLTAGE ADJUST potentiometer, R35. The voltage from R35 goes to U1A-2 and is compared to U1A-3, the reference voltage input. The differential voltage appears at U1A-1. For example, if U1A-2 becomes less positive, the output at U1A-1 becomes more positive, causing Q7 to conduct harder. Increased collector current at Q7 causes increased base-emitter current at Q6. As a result, Q6 conducts harder, with a resultant higher (more positive) regulated output voltage at J5-6.

**2.3.2.3** The circuitry described in the previous paragraph is a negative feedback loop. It maintains a constant output voltage for changes in load or input voltage. The feedback loop has typically 40 dB of gain at dc to give a load/line regulation of  $\pm 0.1$  V dc maximum from no load to full load. As an example, for an increase in load current, the regulator output voltage would normally decrease. The reduced output voltage is sensed at U1A-2, which is now less positive than U1A-3, the reference voltage. U1A-1 goes more positive and drives Q7 into further conduction. An increase in collector current of Q7 causes increased conduction of Q6 which returns the regulated output voltage to normal. A decrease in load current causes the opposite action.

**2.3.2.4** The overcurrent protection circuitry is of the current foldback type. As the load increases beyond the knee, the output voltage and current decrease simultaneously to a final short circuit current of 0.77 amp maximum. The current is sensed across R20. When this voltage exceeds about 0.3 volts (representing a load current of about 2.3 amps), Q8 is forward biased and starts to conduct. Its collector goes positive, causing Q9 to conduct thru R23 and R25. Q9 conducting lowers the voltage at R28 (VREF). As the voltage on U1A-3 lowers, it causes the voltage on U1A-1 to go lower, forcing Q7 and Q6 to conduct less. As a result, the output voltage (9.4 V regulated) decreases. As output current increases, Q8 and Q9 conduct harder resulting in higher

Q6 impedance. This action continues until the output voltage decreases to about 6.5 V. At this point, CR10 becomes forward biased, and the emitter current of Q10 increases. This results in an increased voltage across R21. This will forward bias Q8 harder. As a result less output current can be drawn under a short circuit condition. This is desirable because the power dissipated in Q6 is now reduced.

### 2.3.3 14 V Regulator

**2.3.3.1** The 14 V regulator is a series pass type circuit using PNP transistors (Q1 and Q11). A PNP type transistor can provide voltage regulation with as little as 0.7 V differential between collector and emitter. This means that the input voltage can go as low as 14.7 V, and the circuitry will still maintain voltage regulation. The voltage regulator circuitry provides output voltage adjustment, correction for changes of input voltage and load current, and overcurrent protection.

**2.3.3.2** The input filter circuitry provides power to the 14 V regulator. CR1 and CR15 rectify ac to dc (26-34 V). Resistors R47 and R48 limit the surge and reduce the ripple current filter capacitor C1.

**2.3.3.3** The 14 V regulated (J5-2) is set by the 14 V VOLTAGE ADJUST potentiometer, R7. The voltage from R7 goes to U1C-9 and is compared to U1C-10, the reference voltage input. The differential voltage appears at U1C-8. For example, if U1C-9 becomes less positive, the output at U1C-8 becomes more positive, causing Q2 to conduct harder. Increased collector current at Q2 causes increased base-emitter current at Q1 and Q11. As a result Q1 and Q11 conduct harder, with a resultant higher (more positive) regulated output voltage at J5-2.

**2.3.3.4** The circuitry described in the previous paragraph is a negative feedback loop. It maintains a constant output voltage for changes in load or input voltages. The feedback loop has typically 40 dB of gain at dc to give a load/line regulation of  $\pm 0.1$  V dc maximum from no load to full load. As an example, for an increase in load current, the regulator output voltage would normally decrease. The reduced output voltage is sensed at U1C-9, which is now less positive than U1C-10, the reference voltage input. U1C-8 goes more positive and drives Q2 into further conduction. An increase in collector current of Q2 causes increased conduction of Q1 and Q11. The regulator output returns to normal. A decrease in load current causes the opposite action.

**2.3.3.5** The overcurrent protection circuitry is of the current foldback type. As the load increases beyond the knee, the output voltage and current decrease simultaneously to a final short circuit current of 0.77 ampere maximum. The current is sensed across R10. When this voltage exceeds about 0.3 volts (representing a load current of about 2.3 amperes), Q3 is forward biased and starts to conduct. Its collector goes positive, causing Q4

to conduct through R13 and R14. Q4 conducting lowers the voltage at R9 (V REF). As the voltage on U1C-10 lowers, it causes the voltage on U1C-8 to go lower forcing Q2, Q1, and Q11 to conduct less. As a result, the output voltage (14 V regulated) decreases. As output current increases, Q3 and Q4 conduct harder, resulting in higher Q1 and Q11 impedance. This action continues until the output voltage decreases to about 6.5 V. At this point, CR5 becomes forward biased, and the emitter current of Q5 increases. This results in an increased voltage across R11. This will forward bias Q3 harder. As a result less output current can be drawn under a short circuit condition. This is desirable because the power dissipated in Q1 and Q11 is now reduced.

### 2.3.4 Temperature Compensated Overcurrent Amplifier

The temperature compensated overcurrent amplifier (U1D) compensates the knee of the 9.4 V and 14 V overcurrent detect circuits (Q3 and Q8). Compensation allows operation from -30°C to +80°C without major degradation in available output current. Compensation begins at diodes CR13 and CR14. These diodes are temperature sensitive, having a voltage decrease of about 2 mV from an increase of each degree centigrade. A temperature increase makes U1D-14 less positive. Both Q5 and Q10 reduce collector current with a reduction in voltage drop across R11 and R21. The reduced bias voltage developed across these resistors counteracts the effects of high ambient temperatures on Q3 and Q8.

### 2.3.5 Local Control Inhibit Inverter

The local control inhibit inverter (U1B) is used to turn off the 9.4 V and 14 V voltage regulators externally for local control operation. When used, jumper JU2 is removed, and J5-5 is connected to ground through the normally closed contacts of a switch. Opening the switch contacts causes U1B-7 to go high. Both Q4 and Q9 are driven into saturation. U1C-8 and U1A-1 are pulled low which cuts off Q6, Q1, and Q11.

## 3. REGULATED OUTPUT VOLTAGE ADJUSTMENT PROCEDURE

The regulated output voltages can be adjusted with the auxiliary regulator board in the radio or on the service bench. If adjusted on the test bench, the regulator must be supplied 14 V at J1-1 and +28 V at J1-6 or J1-7. The outputs must be loaded to 1.1 ampere each.

Step 1. Measure the regulated output voltages at TP101 (9.4 V) and TP111 (14 V).

Step 2. Set R35 for 9.4 V  $\pm$  0.1 V.

Step 3. Set R7 for 13.9 V  $\pm$  0.1 V.

## 4. MAINTENANCE

### 4.1 INTRODUCTION

Maintenance and repairs of this power supply demands a thorough understanding of its operation. Refer to the Power Supply Theory of Operation for this information.

### 4.2 TEST EQUIPMENT REQUIRED

The following test equipment is necessary for efficient, accurate servicing in the event that maintenance is required.

- 3-1/2 digit DVM (Motorola Model R1001A or equivalent).
- DC current meter (50 amperes)
- Load resistor (variable from 0 ohms to 15 ohms, and capable of carrying 50 amperes).
- Variable voltage ac line transformer (0-130 volts).
- Oscilloscope.
- Bench service cord consisting of:

| Qty. | Part No.    | Description |
|------|-------------|-------------|
| 1    | 15-83183N01 | Housing     |
| 2    | 39-83145N01 | Contact     |
| 1    | 39-83145N02 | Contact     |
| 1    | 30-865903   | Cord        |

### 4.3 AUXILIARY REGULATOR CHASSIS REMOVAL (Refer to Figure 2)

The circuitry on the auxiliary regulator chassis can be serviced without removing the entire power supply. The auxiliary chassis below the main chassis can be disconnected and removed separately.

Step 1. Disconnect P1 and P5.

Step 2. Remove the three screws holding the auxiliary chassis to the main chassis. Use a magnetic screwdriver.

Step 3. Lift the auxiliary regulator chassis out of the cabinet.

Step 4. Remove circuit board(s) by compressing the plastic locking tabs.



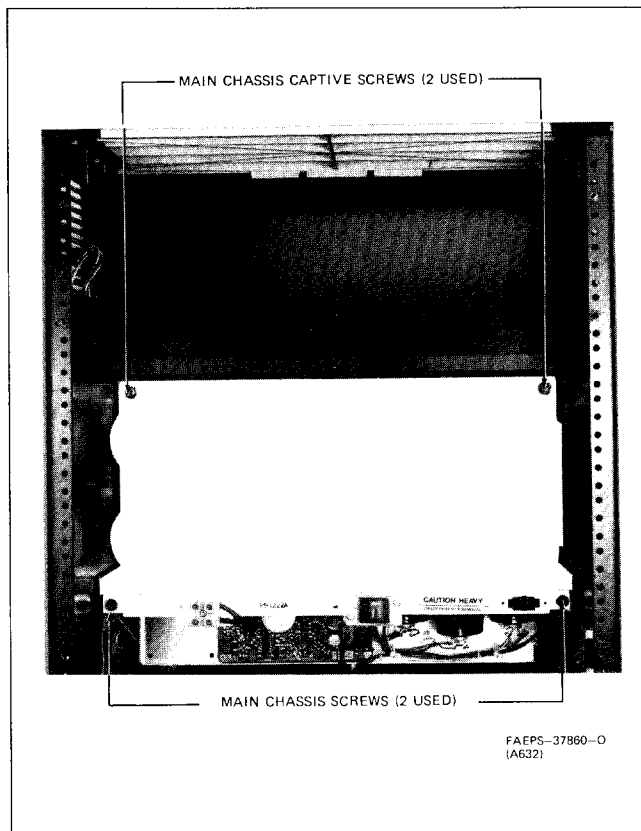

Figure 2. Power Supply Mounting Hardware

#### 4.4 POWER SUPPLY REMOVAL

(Refer to Figures 2 thru 5)

##### **WARNING**

The power supply is unexpectedly heavy, and balances sharply to the right. Follow the removal instructions carefully.

Step 1. Disconnect P5 and P103 (for battery power supply). Open tie wraps and reposition cable.

Step 2. Remove MAIN CHASSIS SCREWS and loosen MAIN CHASSIS CAPTIVE SCREWS. Remove the two shipping screws (Motorola Part No. 3-83498N08) and washers (Motorola Part No. 4-135873) located under the main chassis side rails. These screws need not be replaced when re-installing the power supply unless the station is to be shipped to another location. Retain the screws for further shipping needs.

Step 3. Slide power supply chassis toward you until chassis is flush with cabinet as shown in Figure 3.

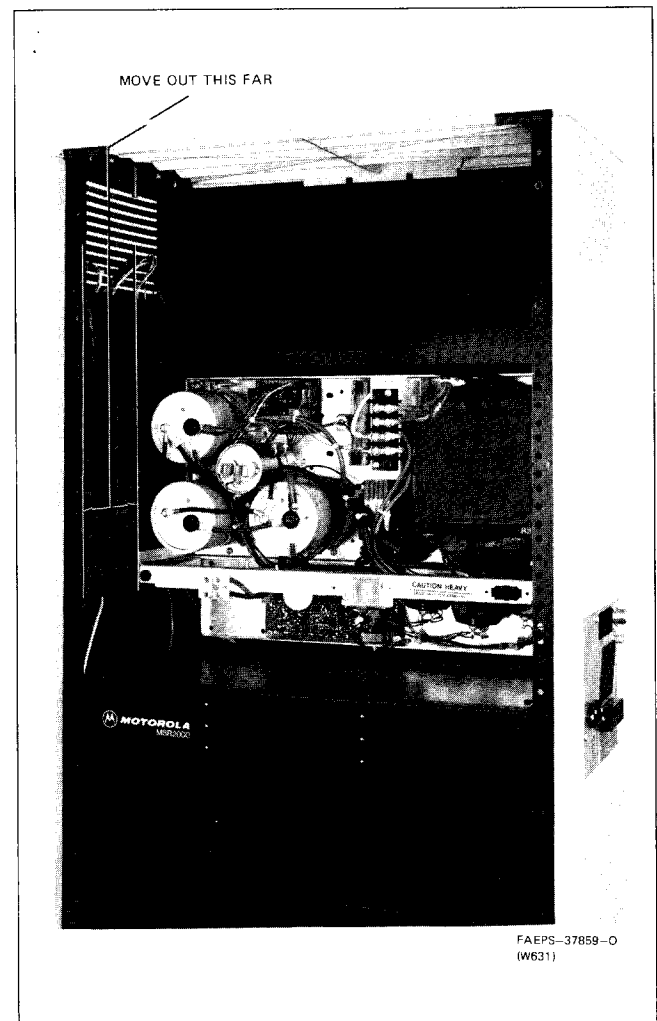

Figure 3. Power Supply Chassis Travel Distance

##### **WARNING**

Do not allow chassis to slide freely beyond front of cabinet: Cabinet rail support ends abruptly.

Step 4. Grip the main chassis with the right hand as shown in Figure 4. Find a comfortable grip around the flattened parts of the metal. Adjacent parts have sharp edges.

Step 5. Plant your feet firmly with good balance to receive a heavy weight.

Step 6. Slide the power supply toward you. Slightly tilt the chassis toward you and reach the left hand over the top to balance the chassis on the cabinet rails. Press the chassis firmly against the rails or the chassis will suddenly slide out of the cabinet. See Figure 5.

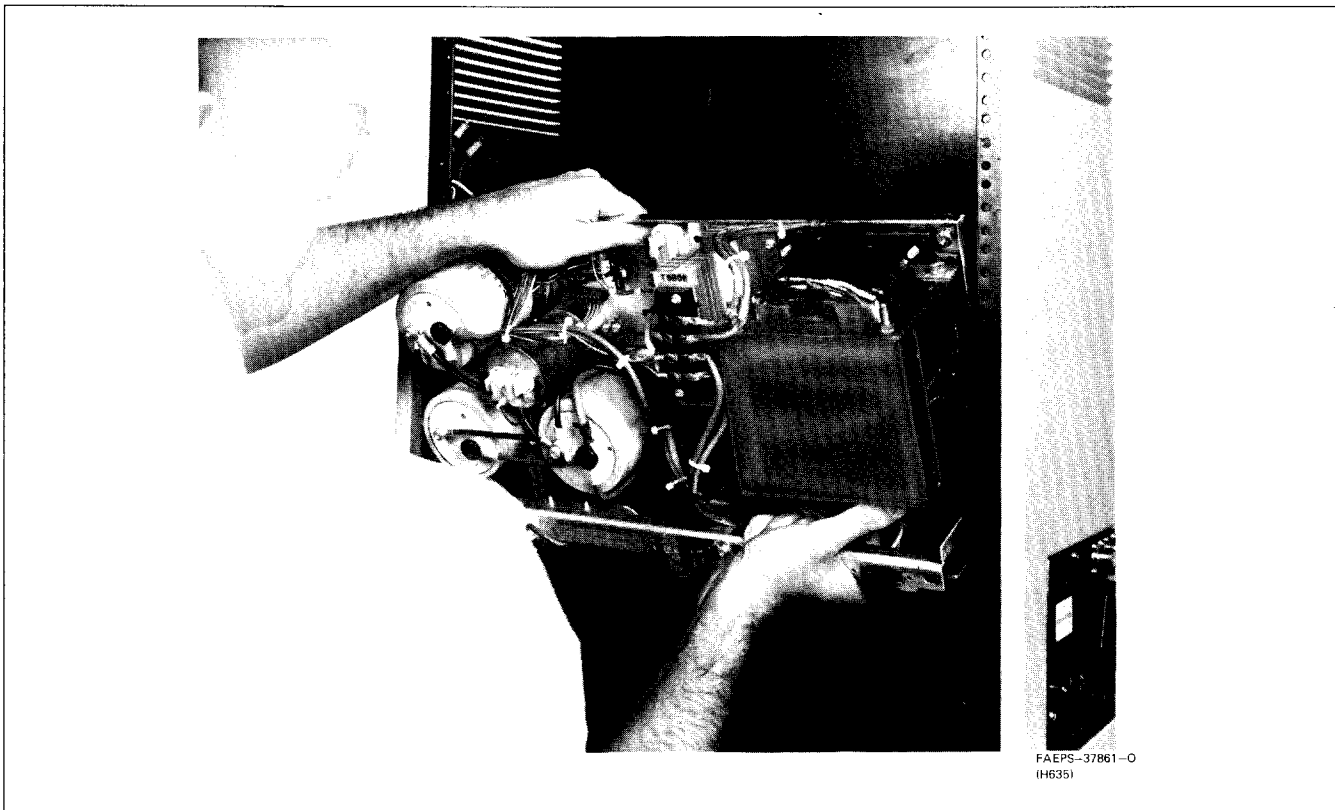

*Figure 4. Properly Gripped Chassis*

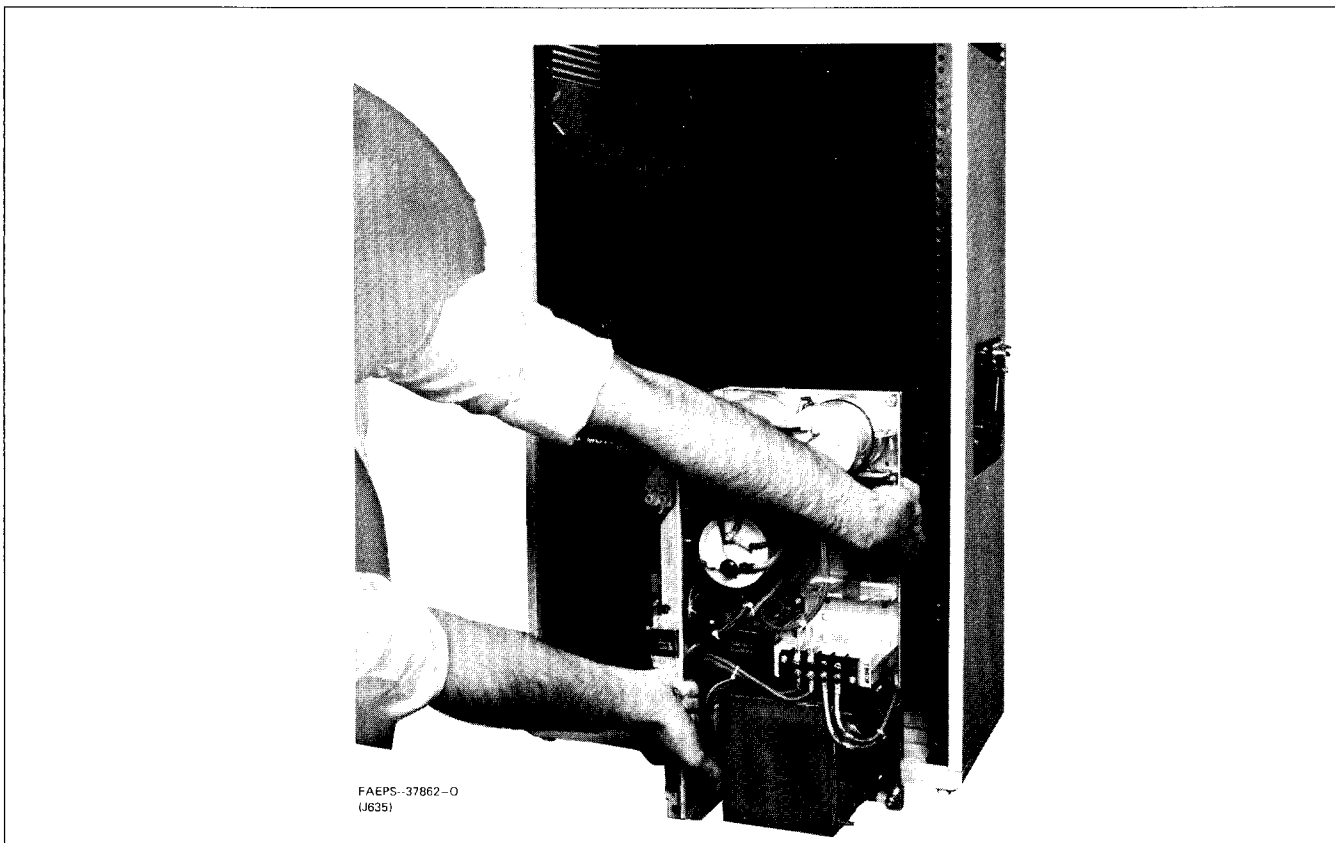

*Figure 5. Power Supply Removed From Cabinet*

Step 7. Reposition the left hand from balancing the chassis to a firm grip.

Step 8. Brace your body to receive a heavy weight, and lift the power supply chassis free of the cabinet.

Table 3. Troubleshooting Chart

| Symptom  | Corrective Action   |
|--|---|
| A. No output voltage   | <ol style="list-style-type: none"> <li>1) Check primary line connection to supply.</li> <li>2) Check transformer secondary voltage at TB601.</li> <li>3) Check power rectifiers CR601 and CR602.</li> </ol>   |
| B. No regulated output voltages  | <ol style="list-style-type: none"> <li>1) Check for approximately 14 volts at J1-1. If no voltage, check fuse F603.</li> <li>2) Check for approximately 6.5 volts at TP105, 6.5 V REF. If no voltage, check CR2 and VR1.</li> <li>3) Check for grounded CR4 and CR8, REGULATOR INHIBIT lead.</li> <li>4) Check for defective U1B.</li> <li>5) Check for defective U1D.</li> </ol> |
| C. 9.4 V regulated output: OK. No 14 V regulated output.                                 | <ol style="list-style-type: none"> <li>1) Check fuses F605 and F604.</li> <li>2) Check Q3 and Q4. TP105 should be 6.5 volts.</li> <li>3) Check U1C.</li> <li>4) Check Q2 for open circuit.</li> <li>5) Check Q1 and Q11 for open circuit.</li> <li>6) Check VR2 for short.</li> <li>7) Check for short circuit at J5-2.</li> </ol>  |
| D. 14 V regulated output: OK. No 9.4 V regulated output                                  | <ol style="list-style-type: none"> <li>1) Check Q8 and Q9. TP104 should be 6.5 volts.</li> <li>2) Check U1A.</li> <li>3) Check Q7 for open circuit.</li> <li>4) Check Q6 for open circuit.</li> <li>5) Check VR3 for short circuit.</li> <li>6) Check for short circuit at J5-6.</li> </ol>   |
| E. Regulators cannot supply full rated current of 1.1A (output drops more than 1 volt.)  | <ol style="list-style-type: none"> <li>1) Check U1D, Q3, Q4, Q8 and Q9.</li> </ol>  |
| F. Regulators short circuit current greater than 0.8A, and possibly input fuse blowing.  | <ol style="list-style-type: none"> <li>1) Overcurrent detect circuits defective. Check U1D, Q3, Q4, Q8 and Q9.</li> <li>2) Check CR5 and CR10.</li> </ol>   |
| G. Regulated output voltages cannot be adjusted to $9.4 \pm 0.1$ V and $13.9 \pm 0.1$ V. | <ol style="list-style-type: none"> <li>1) Check 6.5 V REF. It should be <math>6.5 \pm 0.2</math> volts. If not, check CR2, VR1, and VR4.</li> <li>2) Check regulator feedback loop: U1A, Q7, and Q6; U1C, Q2, Q1 and Q11.</li> <li>3) Check for high leakage Q2 and Q7.</li> </ol>  |
| H. High ac ripple voltage on 14 V regulated output: greater than 10 mV at 1.5A.          | <ol style="list-style-type: none"> <li>1) Check filter capacitor C1 for low capacity or leakage. Ripple voltage at TP100 is greater than 4 V peak-to-peak.</li> <li>2) Check U1C for low loop gain: less than 20 dB.</li> </ol>   |

## parts list

TRN5299A Chassis PL-8013-O

| REFERENCE SYMBOL | MOTOROLA PART NO. | DESCRIPTION                                    |
|------------------|-------------------|--|
| Q1,6,11          | 48-869672         | <b>diode: (see note)</b><br>PNP, type M9672    |
| P3               | 15-83498F39       | <b>connector:</b><br>HOUSING, 3 position (WHT) |
| P4               | 15-83498F40       | HOUSING, 3 position (RED)                      |
| P7               | 15-83498F39       | HOUSING, 3 position (WHT)                      |

### mechanical parts

|             |                                     |
|-------------|-------------------------------------|
| 3-136143    | SCREW, tapping; 8-32 x 1/4"; 6 used |
| 43-83561N01 | STANDOFF, twist lock; 2 used        |
| 3-136850    | SCREW, tapping; 6-32 x 1/2"; 6 used |
| 9-82973A01  | SOCKET, transistor; 3 used          |
| 14-865854   | INSULATOR; 3 used                   |
| 26-82979N01 | HEAT SINK; 3 used                   |
| 29-83499F01 | TERMINAL; 9 used                    |

**note:** For optimum performance, diodes, transistors, and integrated circuits must be ordered by Motorola part numbers.

TRN5297A Hardware Kit  
TRN5298A Hardware Kit PL-8014-O

| REFERENCE SYMBOL | MOTOROLA PART NO. | DESCRIPTION                              |
|------------------|-------------------|--|
| P6,101           | 15-83498F38       | <b>connector:</b><br>HOUSING, 2 position |

### mechanical parts

|             |  |
|-------------|--|
| 3-134185    | SCREW, tapping; 6-32 x 1/4"                    |
| 43-82980N01 | STANDOFF; 3 used TRN5297A; 5 used TRN5298A     |
| 43-82980N02 | STANDOFF, spacer; 2 used TRN5298A              |
| 43-83561N01 | STANDOFF, twist lock; 2 used                   |
| 1-80754D87  | Assembly Wire and Lug includes: (p/o TRN5297A) |
| 29-83499F01 | TERMINAL; 2 used                               |
| 1-80754D97  | Assembly Wire and Lug includes: (p/o TRN5298A) |
| 29-83499F01 | TERMINAL; 2 used                               |
| 1-80754D98  | Assembly Wire and Lug includes: (p/o TRN5298A) |
| 29-83499F01 | TERMINAL; 2 used                               |
| 42-10217A02 | STRAP, ties                                    |

TRN5335A Interconnect Hardware Kit PL-8015-D

| REFERENCE SYMBOL | MOTOROLA PART NO. | DESCRIPTION  |
|------------------|-------------------|--|
| P1,603           | 15-83498F45       | <b>connector:</b><br>HOUSING, 9 position   |
| R610             | 17-83389G03       | <b>resistor, fixed: <math>\pm 5\%</math>; 50 W;</b><br>unless otherwise stated<br>10 |

### mechanical parts

|             |                                       |
|-------------|---------------------------------------|
| 1-80762D67  | RESISTOR, assembly                    |
| 3-10943M25  | SCREW, tapping; M4 x 7 x 20mm; 2 used |
| 3-83498N04  | SCREW, tapping; M4 x 7 x 7mm; 3 used  |
| 42-10217A02 | STRAP, tie; 2 used                    |
| 29-83499F01 | TERMINAL; 14 used                     |
| 29-83113N01 | TERMINAL, right angle                 |
| 29-83113N03 | TERMINAL, right angle                 |
| 46-84549F01 | PLUG, polarizing; 2 used              |
| 4-7651      | WASHER, lock, #8                      |
| 29-82907N07 | TERMINAL, ring                        |

TRN5452A Miscellaneous Power Supply Hardware Kit PL-8269-B

| REFERENCE SYMBOL | MOTOROLA PART NO. | DESCRIPTION                                     |
|------------------|-------------------|---|
| R601             | 17-82177B65       | <b>resistor, fixed:</b><br>10 $\pm 10\%$ ; 50 W |

### non-referenced items

|             |                                     |
|-------------|-------------------------------------|
| 1-80766D10  | ASSEMBLY, resistor cable; includes: |
| 29-83113N01 | TERMINAL, right angle; 4 used       |
| 2-10971A17  | NUT, hex; M4 x 0.7mm                |
| 3-83497N05  | SCREW, machine; M4 x 10mm           |
| 4-7633      | WASHER, flat                        |
| 4-7651      | LOCKWASHER, internal; #8            |
| 43-82980N03 | STANDOFF, support; 4 used           |

## PARTS LOCATIONS & LISTS

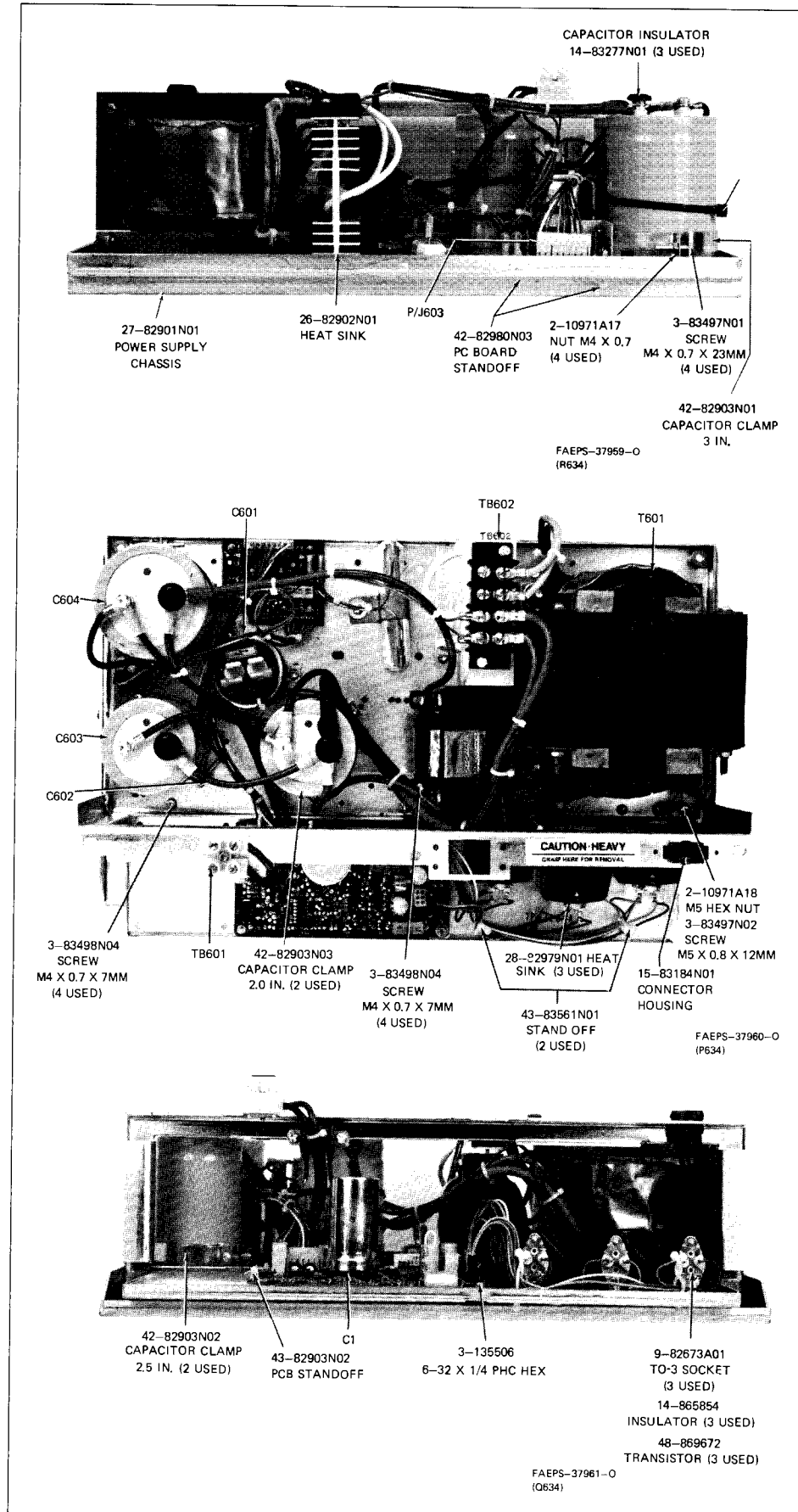

# CABLE INTERCONNECT WIRING DIAGRAM

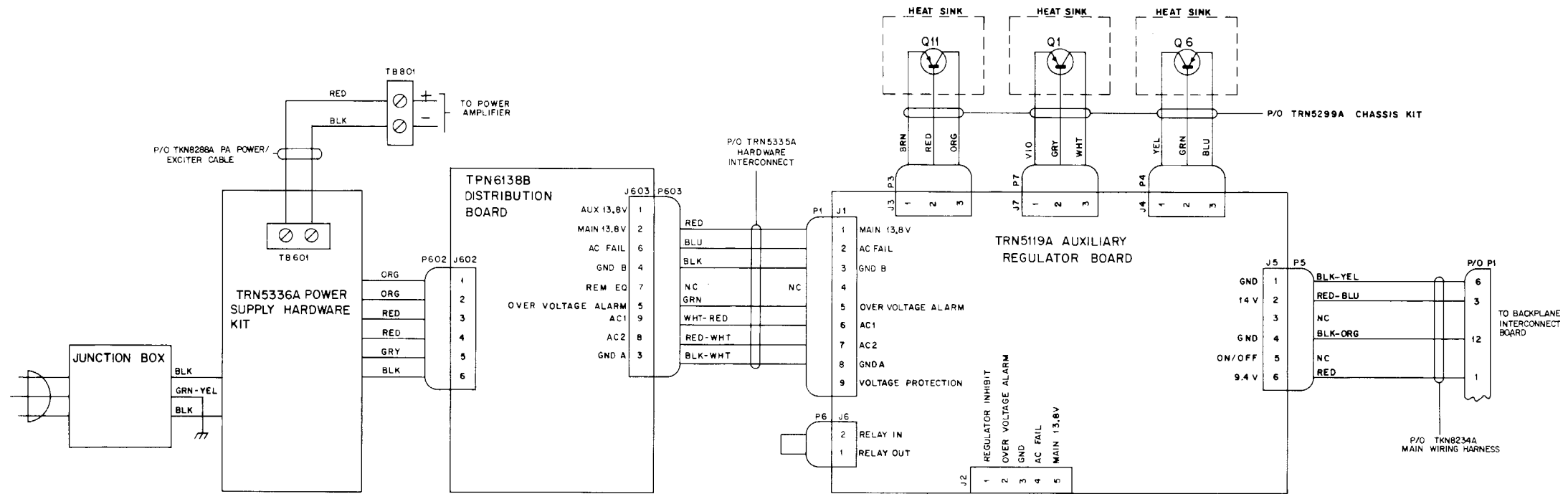

DEPS-34365-A

# STANDARD POWER SUPPLY FUNCTIONAL BLOCK DIAGRAM MODEL TPN1191A

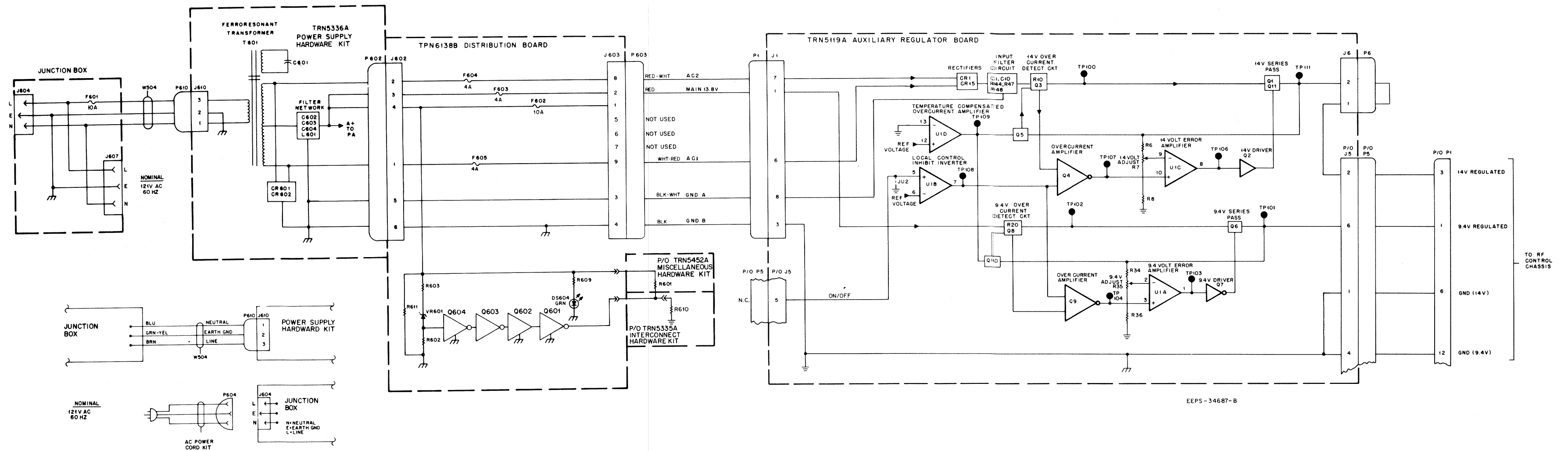

# STANDARD POWER SUPPLY

## MODEL TPN1191A

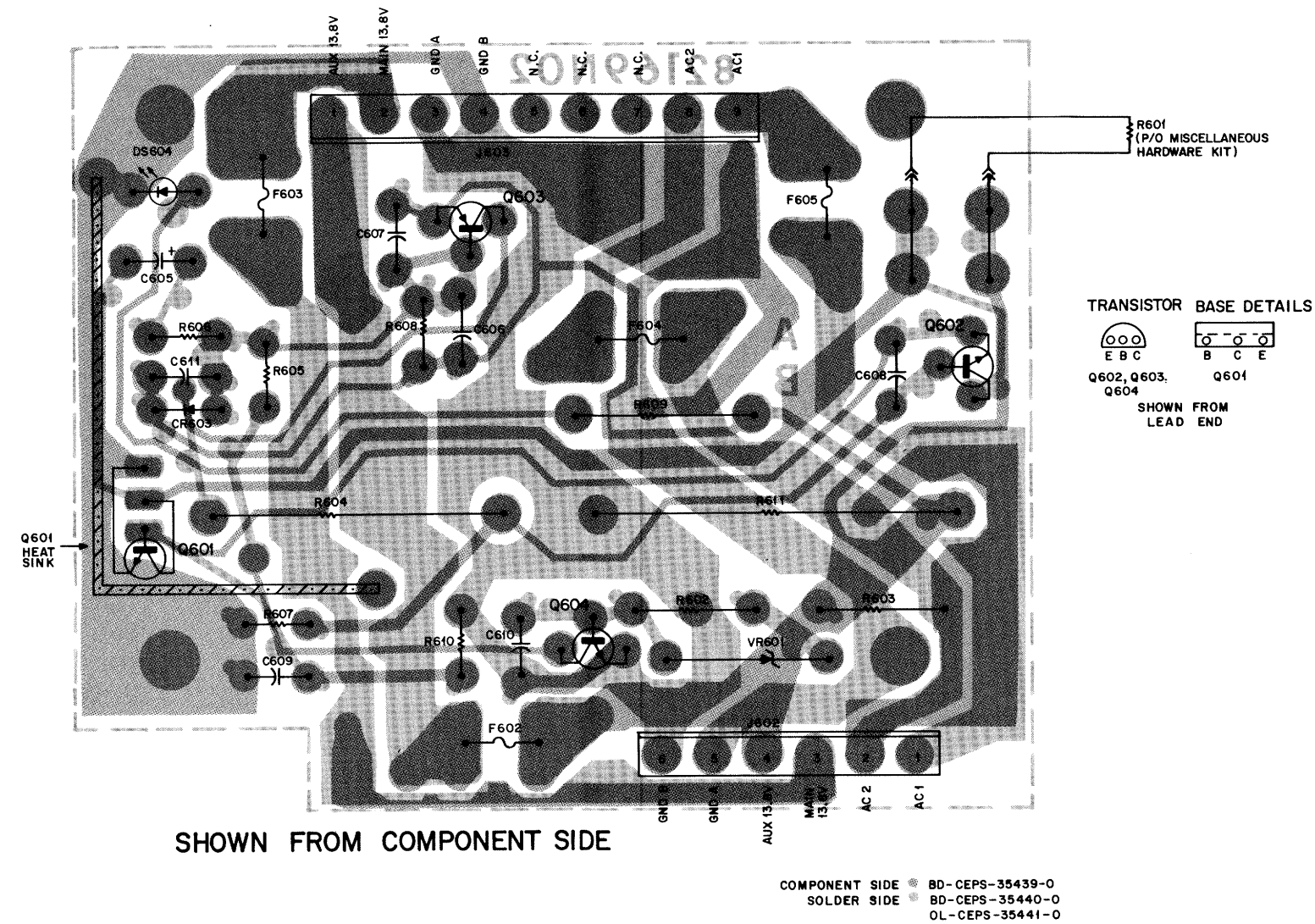

### parts list

TPN6138B Power Supply Distribution Board PL-8265-B

| REFERENCE SYMBOL        | MOTOROLA PART NO.              | DESCRIPTION                           |
|-------------------------|--------------------------------|---------------------------------------|
| C605                    | 23-11019A27                    | capacitor, fixed: 22 uF ± 20%; 25 V   |
| C606                    | 8-11017B08                     | .01 uF ± 10%; 50 V                    |
| C607 thru 611           | 21-11014H32                    | 20 pF ± 5%; 100 V                     |
| CR603                   | 48-11034D01                    | diode (see note) silicon              |
| DS604                   | 48-84404E04                    | light emitting diode: green           |
| F602                    | 65-139767                      | fuse: 10 amp; 32 V                    |
| F603, 604, 605          | 65-82859N01                    | 4 amp; 32 V                           |
| J602                    | 28-82984N06                    | connector, plug: male; 6 contact      |
| J603                    | 28-82984N14                    | male; 9 contact                       |
| Q601                    | 48-869806                      | transistor (see note) NPN; type M9806 |
| Q602                    | 48-869568                      | NPN; type M9568                       |
| Q603                    | 48-869643                      | PNP; type M9643                       |
| Q604                    | 48-869642                      | NPN; type M9642                       |
| R602                    | 6-11009E25                     | resistor, fixed ± 5%; 1/4 W: 100      |
| R603                    | 6-11009E37                     | 330                                   |
| R604                    | 6-127A37                       | 330; 2 W                              |
| R605 thru 608           | 6-11009E69                     | 6.8k                                  |
| R609                    | 6-125C51                       | 1.2k, ± 10%; 1/2 W                    |
| R610                    | 6-11009E35                     | 270                                   |
| R611                    | 17-82177B08                    | 200; ± 10%; 5 W                       |
| VR601                   | 48-83461E18                    | voltage regulator: Zener; 18 V        |
| <b>mechanical parts</b> |                                |                                       |
| 29-82906N01             | TERMINAL, fuse; 8 used         |                                       |
| 2-10971A16              | NUT, machine; M3 x 0.5mm       |                                       |
| 3-83497N04              | SCREW, machine; M3 x 0.5 x 8mm |                                       |
| 4-84180C01              | WASHER, shoulder               |                                       |
| 14-83820M02             | INSULATOR, thermoconductive    |                                       |
| 29-10231A10             | LUG, terminal; 2 used          |                                       |
| 26-84012N01             | SHIELD, amplifier              |                                       |
| 15-84576N01             | HOUSING, fuse clip; 4 used     |                                       |

TRN5336A Power Supply Hardware Kit (500 W) PL-8020-C

| REFERENCE SYMBOL        | MOTOROLA PART NO.                        | DESCRIPTION                              |
|-------------------------|--|--|
| C601                    | 8-82682N01                               | capacitor, fixed: 20 uF ± 6%; 330 V      |
| C602,603                | 23-82681N01                              | 64,000 uF ± 75.7%; 20 V                  |
| C604                    | 23-82681N02                              | 120,000 uF ± 75.10%; 20 V                |
| CR601,602               | 48-82732C09                              | diode (see note) silicon                 |
| P602                    | 9-83360N01                               | connector, receptacle: female; 6 contact |
| L601                    | 25-82686N01                              | coil: choke; 420 uH                      |
| T601                    | 25-82253N01                              | transformer: power; 500 W; 60 Hz         |
| TB601                   | 31-83576K02                              | terminal, board: 2-terminals             |
| <b>mechanical parts</b> |  |  |
| 2-10971A17              | NUT, machine; M4 x 0.7 hex; 4 used       |  |
| 2-10971A18              | NUT, machine; M5 x 0.8 hex; 2 used       |  |
| 3-10907A55              | SCREW, machine; M6 x 1 x 25mm; 4 used    |  |
| 3-83497N01              | SCREW, machine; M4 x 0.7 x 25mm; 4 used  |  |
| 3-83497N02              | SCREW, terminal; M5 x 0.8 x 12mm; 8 used |  |
| 3-83498N04              | SCREW, tapping; M4 x 0.7 x 7mm; 18 used  |  |
| 3-83498N06              | SCREW, tapping; M4 x 0.7 x 16mm; 3 used  |  |
| 3-83678N02              | SCREW, tapping; M3 x 0.5 x 5mm           |  |
| 4-7651                  | LOCKWASHER, #8 internal; 12 used         |  |
| 4-83499N01              | WASHER, insulator; 3 used                |  |
| 4-7658                  | LOCKWASHER, #10 internal; 25 used        |  |
| 5-82904N01              | GROMMET; 4 used                          |  |
| 14-83277N01             | INSULATOR, lug; 3 used                   |  |
| 14-84088N01             | INSULATOR, cap terminals; 2 used         |  |
| 14-84548A01             | INSULATOR, washer; 2 used                |  |
| 26-82902N01             | HEAT SINK                                |  |
| 29-82607B09             | LUG, ring tongue; 2 used                 |  |
| 29-82607B05             | LUG, ring tongue; 4 used                 |  |
| 29-82907N05             | TERMINAL, ring (YEL) 6 used              |  |
| 29-82907N07             | TERMINAL, ring (RED) 2 used              |  |
| 29-83113N01             | TERMINAL, right angle; 6 used            |  |
| 29-83137N01             | TERMINAL, splice; 2 used                 |  |
| 39-83146N01             | CONTACT, socket                          |  |
| 42-85238                | CLAMP, cable; 2 used                     |  |
| 42-10217A02             | STRAP, tie; .091 x 3.62; 16 used         |  |
| 42-35424B03             | STRAP, tie; .094 x 14; 3 used            |  |
| 42-82903N01             | CLAMP, cap; 2"                           |  |
| 42-82903N02             | CLAMP, cap; 2 1/2"; 2 used               |  |
| 42-82903N03             | CLAMP, cap; 3"                           |  |
| 29-82907N06             | TERMINAL, ring (BLU)                     |  |
| 54-83971N01             | LABEL; 2 used                            |  |
| 54-84046N01             | LABEL                                    |  |
| 75-83056P01             | PAD, snap-on                             |  |
| 31-811350               | TERMINAL, board; 4 terminal              |  |

**note:** For optimum performance, diodes, transistors, and integrated circuits must be ordered by Motorola part numbers.

TRN5336A Standard Power Supply Hardware Kit,  
and TRN6138B Distribution Board  
Schematic Diagram, Circuit Board Details,  
and Parts Lists  
Motorola No. PEPS-34737-D  
(Sheet 1 of 2)  
9/30/85-UP

# STANDARD POWER SUPPLY

## MODEL TPN1191A

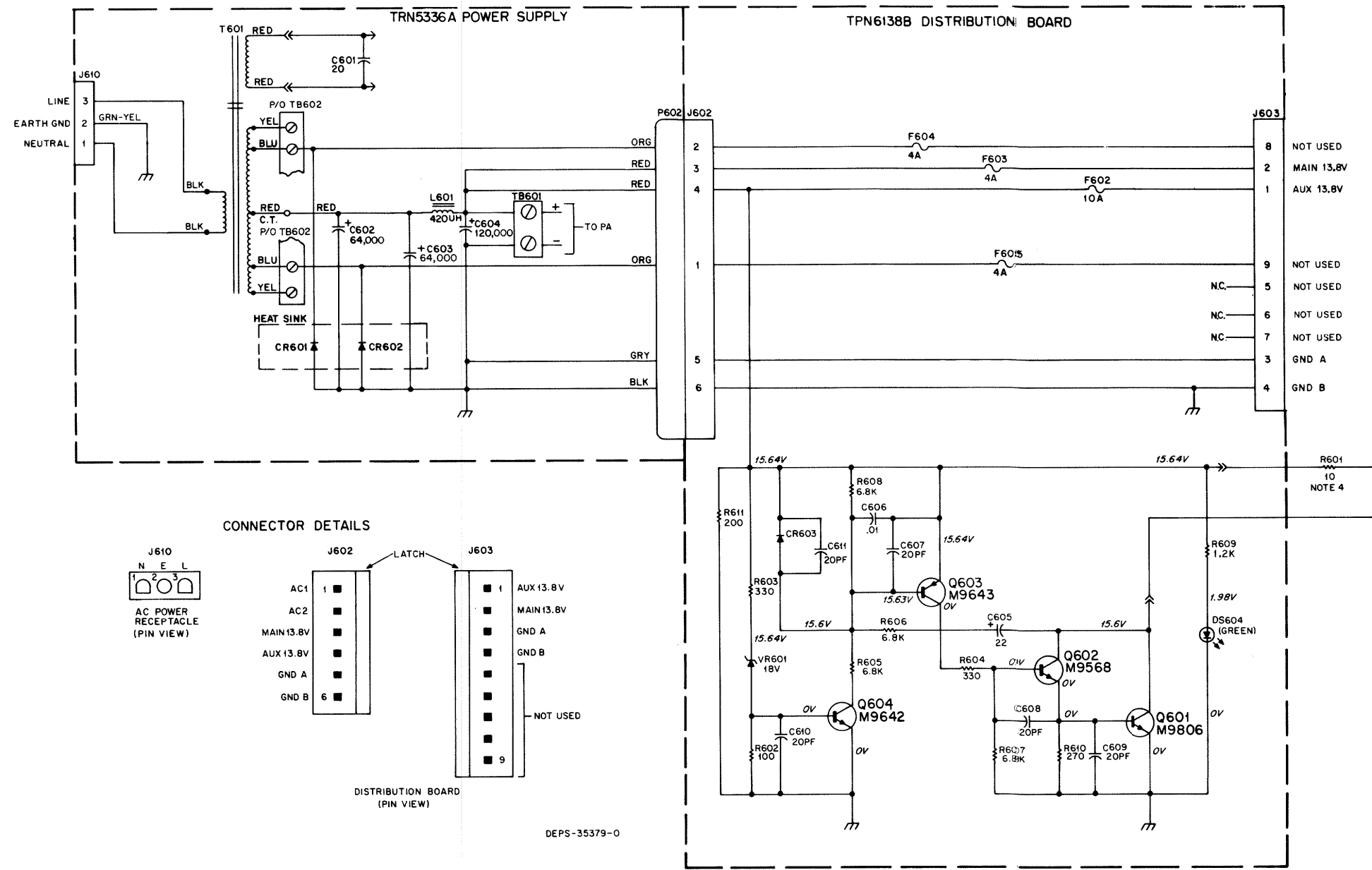

**NOTES:**

1. Unless otherwise indicated: resistor values are in ohms; capacitor values are in microfarads; and inductor values are in millihenries.
2. Voltages measured with DVM, with 1 megohm or greater input resistance.
3. Circuit conditions: load current = 2A, @ 120 V AC (line in).
4. R601 is mounted on power supply chassis.

DEPS-35379-0

*TRN5336A Standard Power Supply Hardware Kit,  
and TRN6138B Distribution Board  
Schematic Diagram, Circuit Board Details,  
and Parts Lists  
Motorola No. PEPS-34737-D  
(Sheet 2 of 2)  
9/30/85-UP*





# STANDARD POWER SUPPLY

MODEL TPN1191A

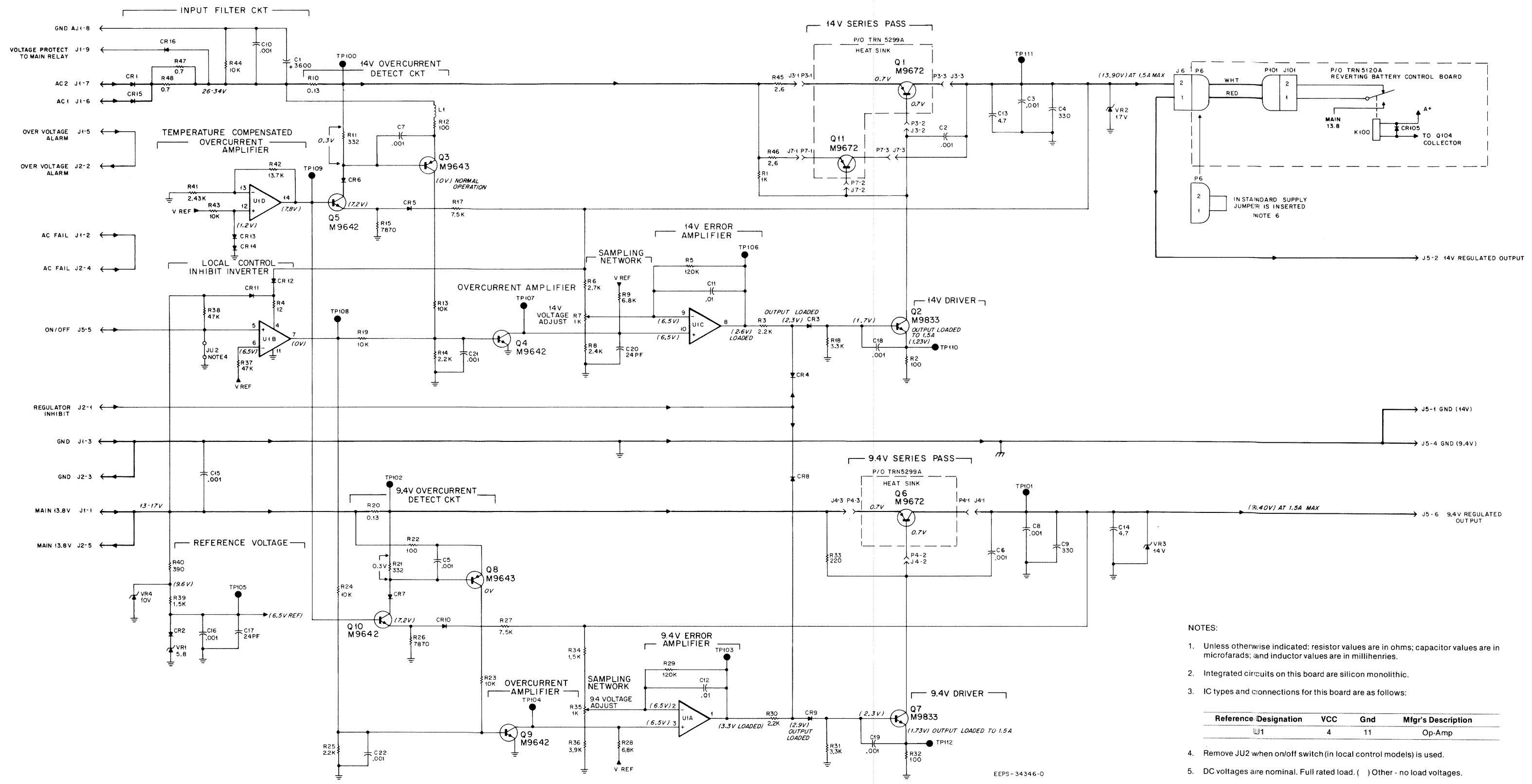

- NOTES:
- Unless otherwise indicated: resistor values are in ohms; capacitor values are in microfarads; and inductor values are in millihenries.
  - Integrated circuits on this board are silicon monolithic.
  - IC types and connections for this board are as follows:
- | Reference Designation | VCC | Gnd | Mfg's Description |
|-----------------------|-----|-----|-------------------|
| U1                    | 4   | 11  | Op-Amp            |
- Remove JU2 when on/off switch (in local control models) is used.
  - DC voltages are nominal. Full rated load. ( ) Other - no load voltages.
  - For non-battery supply (standard supply) insert connector jumper.

TRN5119A Auxiliary Regulator Board  
 Schematic Diagram, Circuit Board Detail,  
 and Parts List  
 Motorola No. PEPS-38130-A  
 (Sheet 2 of 2)  
 9/30/85-UP

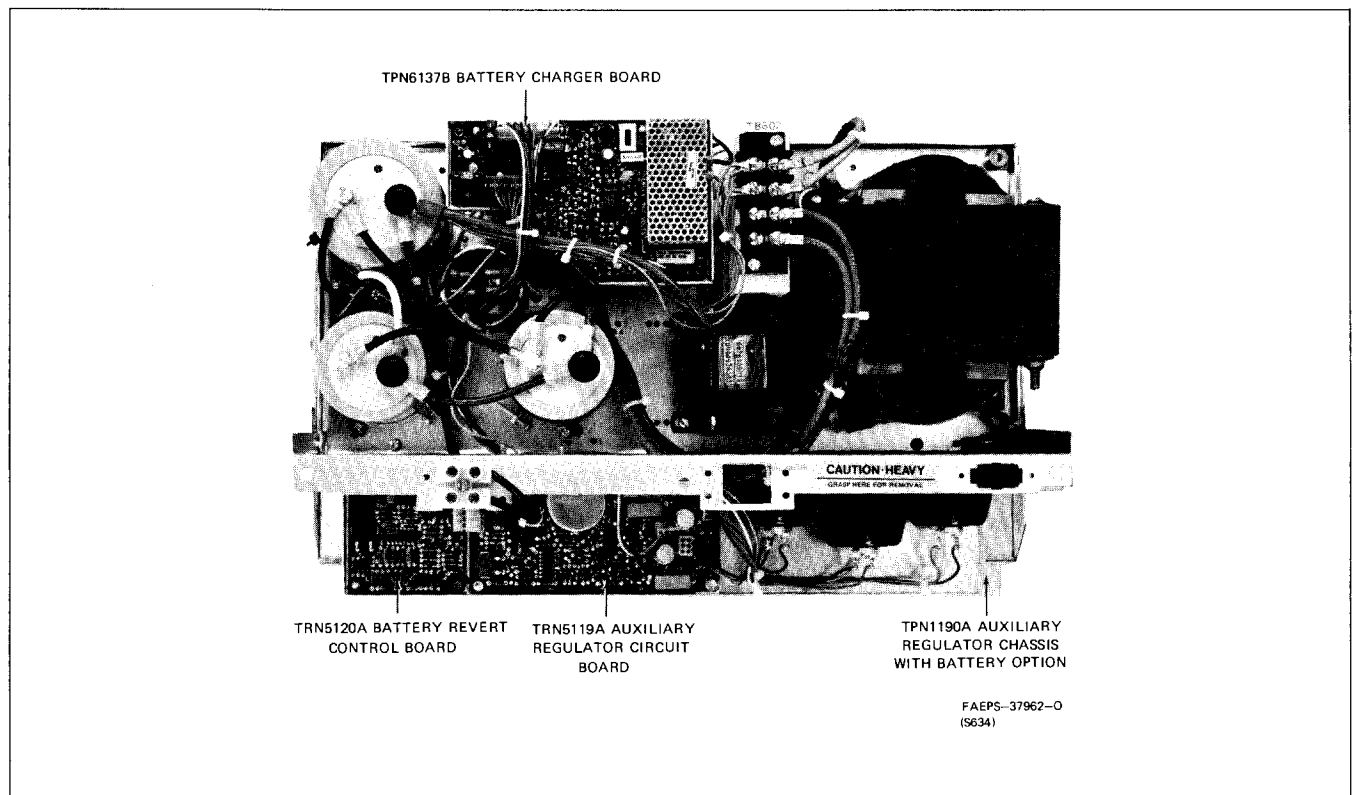
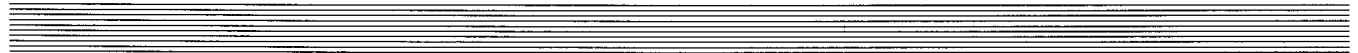

Figure 1. Model TPN1192A Battery Charger Power Supply

## 1. DESCRIPTION

1.1 A C28AN Battery Charger Power Supply is a factory installed accessory that is available for all models of Motorola base and repeater stations. Refer to Table 1 for the model complement of Option C28AN and a model breakdown of Model TPN1192A Battery Charger Power Supply.

1.2 The C28AN option permits the station to operate from 120 volt, 60 Hz ac power normally, but provides continued operation from 12-volt batteries (emergency power) if the ac power should fail. When ac power is

restored, the power supply also operates as a battery charger to recharge the batteries. Refer to Table 2 for performance specifications.

1.3 The C28AN option includes a battery protection and alarm package that is factory installed, to improve emergency power backup by providing an audible alarm whenever the station is operating on batteries. The battery protection and alarm generates an audible alarm tone which "beeps" to indicate that the station is operating on emergency power. This tone burst, with a frequency of about 1400 Hz, is approximately 1/4 second long and repeats at 2-1/2 second intervals. On remote

control stations, or repeater stations with wire line control, the alarm tone is injected into the audio line and is heard at the console (except when transmitting). On repeater stations, without wire line control, the tone is transmitted whenever the transmitter is keyed, so that anyone receiving signals from this station will know that it is operating on emergency power.

**1.4** There are two ways of using the battery protection and alarm. One way is to shut off the low current regulators when the batteries have discharged to a certain level. This connection would protect the battery from damage due to excessive discharge, it also keeps the station from operating from voltages outside normal range.

**1.5** The second method is to keep the regulators running continuously during emergency use. When connected in this manner, the tone burst changes to a continuous tone of about 1400 Hz when the batteries have discharged below a defined level.

**1.6** The C28AN option also includes a 2nd continuous alarm tone which informs the user of a failure in the float charger which may result in battery damage. The tone is a continuous 1400 Hz tone. This overvoltage alarm will disconnect the transformer from the station and allow battery operation in the event of a controller failure.

**1.7** The power supply/battery charger is of the controlled ferroresonant design. The supply provides high current A+ at 14.25 V dc, A+ at 13.90 V dc, and 9.4 V dc to power any continuous or intermittent duty radio. Current limiting, short circuit and over-voltage protection are also provided.

**1.8** The batteries used as the emergency source can be of either the nickel-cadmium or lead-acid type. An automotive type battery is not recommended as an emergency dc supply.

**1.9** A two-position switch on the battery charger board determines the charging rate of the batteries. In the FLOAT position, a voltage is supplied to the batteries, sufficient to maintain them in a fully charged state. The EQUALIZE position increases the charging voltage to restore the batteries after emergency use or where the condition of the battery dictates.

## 2. THEORY OF OPERATION

(Refer to attached diagram for circuit details.)

### 2.1 TRN5336A STANDARD POWER SUPPLY

The TRN5336A Standard Power Supply performs the conversion of ac line power to dc radio power. The supply consists of rectification and filtering. The secondary voltage of transformer T601 is rectified by CR601 and CR602. Ground connection for the diodes is provided

Table 1.  
Model Complement of Option C28AN and  
Model TPN1192A Battery Charger Power Supply

| Kit      | Sub-Kit  | Description                           |
|----------|----------|---------------------------------------|
| TKN8295A |          | Battery Charger Cable                 |
| TRN5155A |          | Battery Cable, External               |
| TPN1192A |          | Battery Charger Power Supply          |
| TPN6137B |          | Battery Charger Circuit Board         |
| TRN5153A |          | Battery Charger Hardware              |
| TRN5336A |          | Domestic Power Supply Hardware        |
| TRN5362A |          | Interconnect Hardware                 |
| TPN1190A |          | Auxiliary Chassis with Battery Option |
|          | TRN5119A | Auxiliary Regulator Circuit Board     |
|          | TRN5120A | Battery Revert Control Circuit Board  |
|          | TRN5209A | Hardware Kit                          |
|          | TRN5299A | Chassis Kit                           |

through the heat sink to chassis. Output filtering is provided by the network of C602, C603, L601, and C604.

### 2.2 TRN6137B BATTERY CHARGER BOARD

Line and load regulation is controlled by the TRN6137B Battery Charger Board. Refer to schematic diagram attached at the end of this section. Regulation is accomplished by controlling the saturation of ferroresonant transformer T601 via a control inductor, L650. This inductor is switched across the resonant winding on the transformer as the output voltage reaches a preset level. Potentiometer R662 (VOLT. ADJ.) permits output voltage adjustment. Switching and timing circuitry for the control inductor is described in the following paragraphs.

#### 2.2.1 Clock Generator

Q655 and Q650 derive a line frequency related clocking signal for timing and triggering purposes.

#### 2.2.2 10 Volt Reference

Zener VR650 establishes a 10 volt reference used by the activity detector, stabilizer, and control voltage generator circuits.

#### 2.2.3 Monostable Switch

U650D converts the clock signal into a monostable pulse which drives the ramp generator.

#### 2.2.4 Ramp Generator

Q651 generates a ramp voltage in conjunction with C653.

#### 2.2.5 Control Voltage Generator

U650A compares a reference voltage with the output voltage and generates a control voltage with gain to the pulse width modulator.

*Table 2. Performance Specifications*

|                       |                         |
|-----------------------|-------------------------|
| Operating Temperature | -30° to +80°            |
| Input Voltage         | 96 V to 132 V ac, 60 Hz |

**HIGH CURRENT OUTPUT**

|                |  |
|----------------|--|
| Output Voltage | 13.1 V Lead Acid<br>14.25 V NiCad and also if any battery is <i>not</i> connected<br>14.1 V Lead Acid Equalize<br>15.25 V NiCad Equalize |
| Output Current | 30.4A at 14.1 V (see graph for other points).  |
| Load Transient | Shall not drop below 11.0 V for a 0 to 30.4A load with the 9.5 V regulator loaded to 1.5A.   |

**9.4 V OUTPUT**

|                 |  |
|-----------------|--|
| Output Voltage  | 9.4 V dc nom. (9.1-9.7 adjustable).                |
| Output Ripple   | Less than 5 mV rms.                                |
| Line Regulation | Shall not change more than 50 mV over input range. |
| Load Regulation | Shall not change more than 0.150 V over load.      |
| Output Current  | 1.1A at 80°C.                                      |

**14 V OUTPUT**

|                                |  |
|--------------------------------|--|
| Output Voltage                 | 13.9 V nom. (13.5-14.1 adjustable).                  |
| Output Ripple                  | Less than 5 mV rms.                                  |
| Line Regulation                | Shall not change more than 25 mV over input voltage. |
| Load Regulation                | Shall not change more than 0.255 V over load.        |
| Output Temperature Coefficient | 1.5 mV/°C typical.                                   |
| Output Current                 | 1.16A at +80°C.                                      |

**ALARM TONE OUTPUT**

|                           |   |
|---------------------------|---|
| Alarm Tone Frequency      | 1400 Hz ± 200 Hz @25°C.                             |
| Alarm Rep Rate            | 1.6 sec. to 4 sec.                                  |
| Alarm Tone Duty Cycle     | 10% typical.  |
| Tone Output Level         | Adjustable from 0 V to 1 V p-p into a 600 ohm load. |
| Low Voltage Dropout Level | Adjustable 10.5 V nominal.                          |

*SPECIFICATIONS SUBJECT TO CHANGE WITHOUT NOTICE*

**2.2.6 Pulse Width Modulator**

U650C compares the control voltage with the ramp and generates a pulse whose width is determined by how early in the ramp cycle the control voltage equals the ramp voltage.

**2.2.7 Stabilizer**

U650B keeps the monostable switch (U650D) from changing state for approximately 1/2 cycle to eliminate triggering errors due to line and load transients.

**2.2.8 Power Switch**

SCR Q656 and TRIAC Q657 work together to switch a control inductance in and out of the resonant winding on the power transformer. The diode bridge between the SCR and TRIAC allows the TRIAC to be triggered every half cycle.

**2.2.9 Overvoltage Protection**

Overvoltage comparator U651A and U651B compares the voltage appearing at the arm of R662 with a fixed voltage developed across a voltage divider consisting of R678, R683, and R655. Any increase or decrease in A+ voltage is reflected at the arm of R662 and applied to U651A-3. If the A+ voltage at U651A-3 rises above the fixed voltage applied to U651A-2, the output at U651A-1 goes high. This action begins charging capacitor C659. If the A+ voltage remains high, C659 will charge to a level above the reference applied to U651B-5. This causes U651B-7 to go high, which in turn, turns on Q660, Q654, and Q653. Once Q660 and Q664 are turned on, the overvoltage protection relay K650 is energized which removes the transformer secondary center tap return path. Relay K650 will now remain energized until ac power and/or battery power is disconnected from the station. Similarly, Q653 will remain turned on to provide the overvoltage alarm output at J603-5 until ac power and/or battery power is disconnected. Zener diode VR651 provides additional protection by forcing the overvoltage circuits to energize in the event that overvoltage sensing through R662 fails.

**2.2.10 Line Fail Sense**

Q658 and Q659 generate a "line fail" signal when a loss of clock signal is detected. Q658 senses failure at the ac line and Q659 generates the output signal AC FAIL.

**2.2.11 Power Up Reset**

Q662 and Q661 use the line fail sense signal from Q658 to generate a power up reset input to the pulse width modulator, U650C, each time power is turned on. The power up reset signal is applied to the control voltage input (U650C-9) of the pulse width modulator and enables quick power up.

**2.3 TRN5119A AUXILIARY REGULATOR BOARD**

The TRN5119A Auxiliary Regulator Board provides regulated 9.4 V and 14 V for the radio. The board circuitry consists of a reference voltage, 9.4 V and 14 V regulators, a temperature-compensated overcurrent amplifier, and a local control inhibit inverter.

### 2.3.1 Reference Voltage

The operational amplifiers on the circuit board require a stable reference voltage. This reference voltage is produced in two stages of circuitry. The first stage consists of VR4 and R40 which are connected to J1-1 and main 13.8 V. Diode VR4 regulates at 9.6 V. The second stage, which operates from this 9.6 V, is temperature compensated and consists of VR1, CR2, and R39. The resultant 6.5 V reference is fed to each of the operational amplifiers.

### 2.3.2 9.4 V Regulator

**2.3.2.1** The 9.4 V regulator is a series pass type circuit using a PNP transistor (Q6). A PNP type transistor can provide voltage regulation with as little as 0.7 V differential between collector and emitter. This means that the input voltage can go as low as 10.4 V, and the circuitry will still maintain voltage regulation. The voltage regulator circuitry provides output voltage adjustment, correction for changes of input voltage and load requirements, and over-current protection.

**2.3.2.2** The 9.4 V regulated output voltage (J5-6) is set by the 9.4 V VOLTAGE ADJUST potentiometer, R35. The voltage from R35 goes to U1A-2 and is compared to U1A-3, the reference voltage input. The differential voltage appears at U1A-1. For example, if U1A-2 becomes less positive, the output of U1A-1 becomes more positive, causing Q7 to conduct harder. Increased collector current at Q7 causes increased base-emitter current at Q6. As a result, Q6 conducts harder, with a resultant higher (more positive) regulated output voltage at J5-6.

**2.3.2.3** The circuitry described in the previous paragraph is a negative feedback loop. It maintains a constant output voltage for changes in load or input voltage. The feedback loop has typically 50 dB of gain at dc to give a load/line regulation of  $\pm 0.1$  V dc maximum from no load to full load. As an example, for an increase in load current, the regulator output voltage would normally decrease. The reduced output voltage is sensed at U1A-2, which is now less positive than U1A-3, the reference voltage. U1A-1 goes more positive and drives Q7 into further conduction. An increase in collector current of Q7 causes increased conduction of Q6. The regulated output voltage returns to normal. A decrease in load current causes the opposite action.

**2.3.2.4** The overcurrent protection circuitry is of the current foldback type. As the load increases beyond the knee, the output voltage and current decrease simultaneously to a final short circuit current of 0.77 amp maximum. The current is sensed across R20. When this voltage exceeds about 0.3 volt (representing a load current of approximately 2.3 amps), Q8 is forward biased and starts to conduct. When Q8 conducts, its collector goes positive, turning on Q9. The conduction of Q9 increases the voltage drop across R28 causing the voltage

at U1A-3 to drop. The drop in voltage of U1A-3 causes a corresponding drop in voltage of U1A-1. This action causes Q7 and Q6 to conduct less current. As a result, the output voltage (9.4 V regulated) decreases. If the output current continues to increase, Q8 and Q9 conduct harder which results in a further reduction in voltage through Q6. This action continues until the output voltage drops to approximately 6.5 V. At this point, CR10 becomes forward biased increasing the current through Q10. This action causes Q8 to conduct harder which, through Q9, U1A, and Q7, reduces the current through Q6. Notice, therefore, a short circuit at the output of Q6 actually results in less dissipation through Q6 than full normal operating load. This prevents damage to Q6 due to overcurrent conditions.

### 2.3.3 14 V Regulator

**2.3.3.1** The 14 V regulator is a series pass type circuit using PNP transistors (Q1 and Q11). A PNP type transistor can provide voltage regulation with as little as 0.7 V differential between collector and emitter. This means that the input voltage can go as low as 14.7 V, and the circuitry will still maintain voltage regulation. The voltage regulator circuitry provides output voltage adjustment, correction for changes of input voltage and load current, and overcurrent protection.

**2.3.3.2** The input filter circuitry provides power to the 14 V regulator. CR1 and CR15 rectify ac to dc (26-34 V). Resistors R47 and R48 limit the surge and reduce the ripple current across filter capacitor C1.

**2.3.3.3** The 14 V regulated (J5-2) output is set by the 14 V VOLTAGE ADJUST potentiometer, R7. The voltage from R7 goes to U1C-9 and is compared to U1C-10, the reference voltage input. The differential voltage appears at U1C-8. For example, if U1C-9 becomes less positive, the output at U1C-8 becomes more positive, causing Q2 to conduct harder. Increased collector current at Q2 causes increased base-emitter current at Q1 and Q11. As a result Q1 and Q11 conduct harder, with a resultant higher (more positive) regulated output voltage at J5-2.

**2.3.3.4** The circuitry described in the previous paragraph is a negative feedback loop. It maintains a constant output voltage for changes in load or input voltages. The feedback loop has typically 50 dB of gain at dc to give a load/line regulation of  $\pm 0.1$  V dc maximum from no load to full load. As an example, for an increase in load current, the regulator output voltage would normally decrease. The reduced output voltage is sensed at U1C-9, which is now less positive than U1C-10, reference voltage input. U1C-8 goes more positive and drives Q2 into further conduction. An increase in collector current of Q2 causes increased conduction of Q1 and Q11. The regulator output returns to normal. A decrease in load current causes the opposite action.

**2.3.3.5** The overcurrent protection circuitry is of the current foldback type. As the load increases beyond the knee, the output voltage and current decrease simultaneously to a final short circuit current of 0.77 ampere maximum. The current is sensed across R10. When this voltage exceeds about 0.3 volts (representing a load current of about 2.3 amperes), Q3 is forward biased and starts to conduct. Its collector goes positive, causing Q4 to conduct thru R13 and R14. Q4 conducting lowers the voltage at R9 (V REF). As the voltage on U1C-10 lowers, it causes the voltage on U1C-8 to go lower, forcing Q2, Q1, and Q11 to conduct less. As a result, the output voltage (14 V regulated) decreases. As output current increases, Q3 and Q4 conduct harder, resulting in higher Q1 and Q11 impedance. This action continues until the output voltage decreases to about 6.5 V. At this point, CR5 becomes forward biased, and the emitter current of Q5 increases. This results in an increased voltage across R11. This will forward bias Q3 harder. As a result less output current can be drawn under a short circuit condition. This is desirable because the power dissipated in Q1 and Q11 is now reduced.

### **2.3.4 Temperature Compensated Overcurrent Amplifier**

The temperature compensated overcurrent amplifier (U1D) compensates the knee of the 9.4 V and 14 V overcurrent detect circuits (Q3 and Q8). Compensation allows operation from  $-30^{\circ}\text{C}$  to  $+80^{\circ}\text{C}$  without degradation in available output current. Compensation begins at diodes CR13 and CR14. These diodes are temperature sensitive, having a voltage decrease of about 2 mV for an increase of each degree centigrade. A temperature increase makes U1D-14 less positive. Both Q5 and Q10 reduce collector current with a reduction in voltage drop across R11 and R21. The reduced voltage across the bias resistors counteracts the effects of high ambient temperatures on Q3 and Q8.

### **2.3.5 Local Control Inhibit Inverter**

The local control inhibit inverter (U1B) is used to turn off the 9.4 V and 14 V voltage regulators externally for local control operation. When used, jumper JU2 is removed, and J5-5 is connected to ground thru the normally closed contacts of a switch. Opening the switch causes U1B-7 to go high. Both Q4 and Q7 are driven into saturation. U1C-8 and U1A-1 are pulled low which cuts off Q6, Q1, and Q11.

### **2.3.6 Overvoltage Protection Relay**

On battery charging supplies, in the event of an overvoltage alarm, relay K650 will pull in to prevent overcharging of the battery system. With the wiper of K650 tied to the transformer center tap, the relay "pull in" will disconnect the high current A+ from the filter section. In addition to disconnecting the filter section, K650 opens the fuses F604 and F605 which feed the auxiliary regula-

tor. By tying the positive terminal of C1 in the AUX regulator (via CR16) to the normally open contact of K650, the transformer windings are presented a relatively low impedance path through F604 and F605 when K650 energizes.

## **2.4 TRN5120A BATTERY REVERT CONTROL BOARD**

The TRN5120A Battery Revert Control Board is a supervisory control board designed to regulate the transition from ac main power to battery back-up operation. To accomplish this the board: 1) switches out the 14 V regulator in the event of a power failure or controller failure, 2) monitors battery condition to prevent over-discharge, and 3) generates alarm tones to indicate ac power failures or controller failures.

### **2.4.1 Regulator Output Switching**

**2.4.1.1** In conditions where battery operation is required (i.e., ac power failure or controller failure) it is necessary to switch the low current A+ (regulated 14 V) load from the regulator output to the battery due to the high losses in the 14 V regulator. By using a relay to switch the output, the battery revert control board achieves a reduced IR loss between the battery and the load, which serves to lengthen the amount of time the user has to run his station.

**2.4.1.2** The relay (K100) is controlled by the AC Fail and 0 V alarm signals which are generated in the ferroresonant controller. These signals are applied to the base of Q101 (AC Fail directly, and 0 V alarm through CR107) and are normally high. When these signals are high, the collector of Q101 saturates, preventing the relay driver (Q104) from turning on the relay.

### **2.4.2 Low Battery Voltage Dropout**

**2.4.2.1** When either AC Fail or 0 V alarm are low, a voltage comparator monitors the battery voltage to determine the battery condition. When the voltage drops below a certain voltage, the comparator shuts off the relay (K100), inhibits the low current regulators, and forces the alarm tone generator to produce a continuous tone.

**2.4.2.2** The comparator consists of a Norton mode op amp (U100-C) biased to function as an inverting Schmitt trigger with an adjustable trigger level (R129) and a reset/inhibit input (via CR111). Under normal operation (AC Fail and 0 V alarm high), the comparator output is held low since Q101 is saturated, Q102 is shut off, and the current applied to U100C-8 through R106, CR111, and R111 is greater than the current applied to U100C-13 through R112. When AC Fail or 0 V alarm goes low, Q101 shuts off and Q102 saturates. This action back biases CR111 preventing any current flow through R111 thereby allowing the comparator to func-

tion. Once the A+ voltage drops below a certain voltage (manually set using R129) the comparator output goes high, causing Q103 and Q105 to saturate. The collector of Q103 is tied to the base of Q104, which drives the relay. Once Q103 saturates, no current flows in the base of Q104, shutting off K100. Q105 is tied to Q2 and Q7 (via CR4 and CR8) of the regulator. When Q105 saturates, the base drive of Q2 and Q7 is drawn off, causing the pass elements in the regulators to shut off. The comparator output is also fed into the pulse inhibit input of the pulse generator which causes the pulse generator to inhibit when the comparator output is high.

### 2.4.3 Alert Tone Generation

**2.4.3.1** The battery revert control board is designed to provide two alert signals. The first is a pulsed 1400 Hz tone which indicates the loss of ac power. The second is a continuous 1400 Hz tone which indicates conditions which may result in battery damage.

**2.4.3.2** By noting the sequence in which the continuous tone appears, the user can determine the nature of the problem. When a pulsed tone (indicating loss of ac power) is followed by a continuous tone, the user can assume that the batteries are fully discharged, and station operation may not last much longer. A continuous tone which suddenly appears, indicates that failure of the power supply has occurred and that battery operation has commenced.

**2.4.3.3** The alert tones are generated by a phase shift oscillator whose output is gated by a pulse generator. This pulse generator is then controlled by a combination of AC Fail, 0 V alarm and the voltage comparator output.

**2.4.3.4** The tone generator consists of a Norton type op amp (U100-B) with a phase shift feedback path to cause oscillation. A tone inhibit function has been added by tying the output of Q102 to the inverting input (via R134). When Q102 is high (i.e. AC Fail and 0 V alarm are high), enough current is forced into pin 6 of U100-C to cause the oscillator output to clamp to ground. Once Q102 goes low, the oscillator output dc voltage becomes 1/2 the output of the pulse generator which is fed into the non-inverting input of U100-D.

**2.4.3.5** The pulse generator also consists of a Norton type op amp biased as an inverting Schmitt trigger (U100-D) with an RC network added to provide asynchronous switching. Under most conditions, the pulse generator is free running, however when the 0 V alarm goes low or the low voltage comparator output goes high the pulse generator is inhibited, and its output is forced high. The inhibit function is accomplished by applying either the output of U100-C (the low voltage comparator) or U100-A (a simple inverter which inverts 0 V alarm) to the non-inverting input of U100-D which forces the output high.

**2.4.3.6** The tone generator output is fed via R126 and JU102 to R128 which allows the level to be adjusted. By removing JU102, 20 dB of attenuation can be obtained when R128 is at mid setting.

## 3. BATTERY CONNECTION AND INSTALLATION

### 3.1 POWER SUPPLY

**3.1.1** Installation of the station with this option is standard except for the connection of the 12-volt battery (10 cells nickel-cadmium, 6 cells lead-acid).

**3.1.2** Locate the battery in a secure place, and as close to the station as possible. The cable length must be kept as short as practical, because of the voltage drop in the battery cable. A substantial voltage drop can be developed across this low resistance due to the high currents drawn from the battery while transmitting.

**3.1.3** Select a battery location that has an unobstructed air circulation, preferably a cool dry place with ample width aisles to permit easy access to all cells for installation, taking readings, adding water and cleaning. The battery must not be placed near radiators, boilers, or other heat-producing devices.

**3.1.4** Capacity of a battery should be carefully determined before its purchase. Factors that influence the capacity are the busy hour load, the protection time desired, the final cell voltage limit and the minimum operating temperatures. For more information contact your Motorola Area Systems Engineer.

**3.1.5** Connection of the battery terminals made during installation is extremely important to its service life. If connections are carefully made with clean, acidfree surfaces and kept tight by periodic checking, they will give trouble-free service over the life of the battery.

---

#### CAUTION

Do not attach batteries before setting the float voltage.

---

**3.1.6** Adjustment of the float voltage of the power supply is required at the time the battery is installed. The float voltage is the A+ output voltage of the power supply which will keep a battery fully charged when connected across the A+ output terminals. The float voltage adjustment varies with the type of battery being installed and with the ambient temperature. Refer to paragraph 4, Level Adjustments, and to the battery manufacturer's literature for adjustment of the float voltage.



**3.1.7** Give the battery a freshening or boost charge when it is received. Do this in accordance with the manufacturer's instructions.

**3.1.8** Connect the battery cable from the junction box to the battery as follows:

Step 1. Remove fuse F610 from the battery cable to prevent accidental short circuiting during installation.

---

**CAUTION**

Observe proper polarity on battery connections.

---

Step 2. Connect the battery cable plug (P605) to J605 on the junction box, and route the battery cable to the battery connection points.

Step 3. Connect the red wire of the battery cable to the position (+) terminal of the battery.

Step 4. Connect the black wire of the battery cable to the negative (-) terminal of the battery.

Step 5. Check to assure proper polarity of the cable leads, and then reinstall fuse F6501, removed in Step 1.

**3.1.9** If power is to be removed from the station for any reason after the initial installation, the most convenient method is to remove the in-line fuse (F601) from the battery cable.

**3.2 BATTERY PROTECTION AND ALARM**

**3.2.1** The C28 option, as shipped from the factory, is wired to include the low voltage regulator dropout for battery protection. If it is desired to have the low voltage detect circuit to cause a continuous tone alarm rather than shut-off the regulators, cut jumper JU101 on the battery revert control board.

**3.2.2** When ordered with the C28 option, the rf control chassis backplane will be jumpered to provide the alert tone in the phone line for base station operation, or to provide the alert tone in the exciter for repeater station operation. Refer to the following for jumper details.

- Standard Backplane
  - JU6 — IN      Tone in phone line
  - JU7 — OUT
- Optionable Backplane
  - JU13 — IN
  - JU14 — OUT      Base Station Operation
  - JU13 — OUT
  - JU14 — IN      Repeater Station Operation

**4. LEVEL ADJUSTMENTS**

**4.1 A+ VOLTAGE ADJUSTMENT**

The A+ output is factory adjusted for nickel cadmium batteries at 14.25 volts. If adjustment is necessary, set output voltage control, R662, in the station power supply for the desired float voltage as follows:

Step 1. Disconnect batteries and replace F602 if missing.

Step 2. Connect a dc voltmeter with 3% accuracy (or better) between terminals TB601+ and TB601- on the power supply. Allow the power supply to warm up for at least 10 minutes.

Step 3. Set the VOLT. ADJ. control R662 to provide a charging voltage: (a) as specified by the battery manufacturer; (b) of 14.25 volts if batteries are not to be connected at this time; (c) of 14.25 volts for nickelcadmium batteries, or; (d) of 13.1 volts for lead-acid batteries.

---

**CAUTION**

When operating the battery charging power supply without batteries, F602 must be present. F602 should be removed when batteries are present and attached to reduce battery drain via load resistor R140 under ac fail conditions.

---

**4.2 REGULATED OUTPUT VOLTAGE ADJUSTMENT**

The regulated output voltages can be adjusted with the auxiliary regulator board in the radio or on the service bench. If adjusted on the test bench, the regulator must be supplied 14 V at J1-1 and +28 V at J1-6 or J1-7. The outputs must be loaded to 1.1 ampere each.

Step 1. Measure the regulated output voltages at TP101 (9.4 V) and TP111 (14 V).

Step 2. Set R35 for 9.4 V ± 0.1 V.

Step 3. Set R7 for 13.9 V ± 0.1 V.

**4.3 ALARM TONE LEVEL ADJUSTMENT**

In remote control stations, and in repeaters with wire line control, the "tone level" control (R128) on the battery revert control board is factory preset to provide a level -20 dB below the set level on the audio control line. In "repeater only" stations, this control is set for a deviation of ± 0.5 kHz.

The tone level control may be reset to suit the needs of a particular installation by the following procedure.

Step 1. Disconnect the station from the ac power line and allow it to operate on its battery. (This should turn on the alarm tone oscillator.)

Step 2. Set the volume control at a normal comfortable operating level with a received signal.

Step 3. Rotate TONE LEVEL ADJ control R128 until the alarm tone is clearly discernible, but not loud enough to effect the intelligibility of the audio signals on the line. The tone can be turned on continuously by grounding the positive lead of C103.

#### 4.4 LOW-VOLTAGE DETECTOR ADJUSTMENT

Dropout voltage control R129 is factory preset, but may need resetting if any components in the low-voltage detector or associated circuits have been replaced. If it is necessary to readjust the low-voltage detector control, use the following procedure.

Step 1. Disconnect ac and battery power from the station.

Step 2. Connect the output of a variable dc power supply (such as the Motorola R1011A) to TB601 in the power supply. Set the supply to 13.1 V before connecting.

Step 3. Preset low-voltage control R129 to the fully counterclockwise position.

Step 4. Set the output of the variable power supply at 10.5 V.

Step 5. Rotate dropout voltage control R129 clockwise until K100 de-energizes. Read the power supply output voltage just before the point of dropout.

Step 6. Check the relay operation by increasing the supply voltage until the relay pulls in and then reducing it until the relay drops out. Read the supply voltage at the point just before dropout. The relay should drop out when the supply voltage is between 10.0 and 10.8 volts.

Step 7. If the measured dropout voltage was outside the 10.0 to 10.8-volt range, readjust control R129 and recheck until it is within these limits. Clockwise rotation of R129 increases the dropout voltage; counterclockwise rotation decreases it.

Step 8. Turn off the variable power supply and completely disconnect it from TB601.

## 5. MAINTENANCE

### 5.1 INTRODUCTION

Maintenance and repairs of this power supply demand a thorough understanding of its operation. Refer to the power supply Theory of Operation for this information.

### 5.2 TEST EQUIPMENT REQUIRED

The following test equipment is necessary for efficient, accurate servicing in the event that maintenance is required.

- 3-1/2 digit DVM
- DC current meter (0-50 amperes)
- Load resistor (variable from 0 ohm to 15 ohms, and capable of carrying 50 amperes)
- Variable voltage ac line transformer (0-130 volts)
- Oscilloscope
- Variable power supply
- Bench service cord consisting of:

| Qty | Part No.    | Description |
|-----|-------------|-------------|
| 1   | 15-83183N01 | Housing     |
| 2   | 39-83145N01 | Contact     |
| 1   | 39-83145N02 | Contact     |
| 1   | 30-865903   | Cord        |

### 5.3 AUXILIARY REGULATOR CHASSIS REMOVAL

(Refer to Figure 2.)

The circuitry on the auxiliary regulator chassis can be serviced without removing the entire power supply. The auxiliary chassis below the main chassis can be disconnected and removed separately.

Step 1. Disconnect P1 and P5.

Step 2. Remove the three screws holding the auxiliary chassis to the main chassis. Use a magnetic screwdriver.

Step 3. Lift the auxiliary regulator chassis out of the cabinet.

Step 4. Remove circuit board(s) by compressing the plastic locking tabs.

### 5.4 POWER SUPPLY REMOVAL

(Refer to Figures 2 thru 5.)

---

#### WARNING

The power supply is unexpectedly heavy, balances sharply to the right, and is awkward to hold. Follow the removal instructions carefully.

---

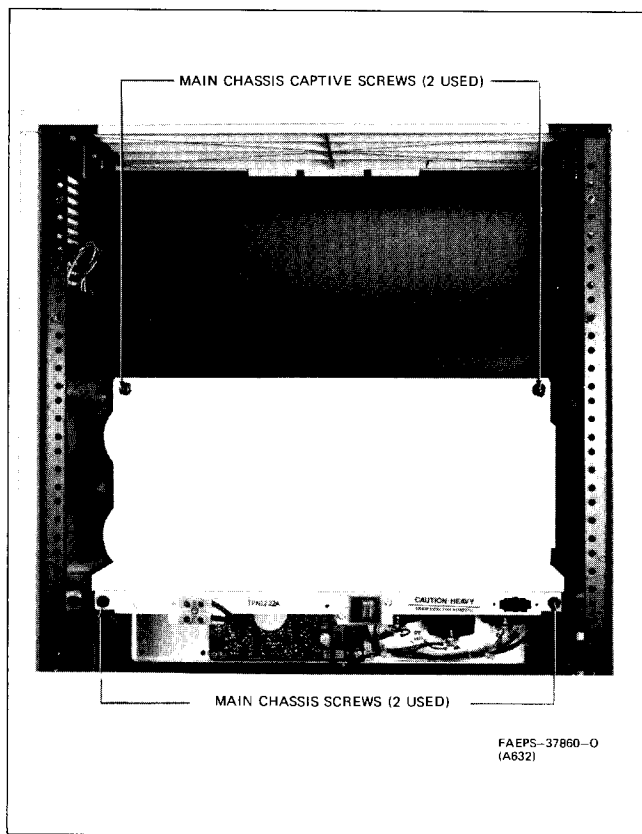

Figure 2. Power Supply Mounting Hardware

Step 1. Disconnect P5 and P103 (for battery power supply). Open tie wraps and reposition cable.

Step 2. Remove main chassis screws and loosen main chassis captive screws. Remove the two shipping screws (Motorola Part No. 3-83498N08) and washers (Motorola Part No. 4-135873) located under the main chassis side rails. These screws need to be replaced when re-installing the power supply unless the station is to be shipped to another location. Retain the screws for future shipping needs.

Step 3. Slide power supply chassis to you until chassis is flush with cabinet as shown in Figure 3.

**WARNING**  
DO NOT ALLOW CHASSIS TO SLIDE FREELY BEYOND FRONT OF CABINET. CABINET RAIL SUPPORT ENDS ABRUPTLY.

Step 4. Grip the main chassis with the right hand as shown in Figure 4. Find a comfortable grip around the flattened parts of the metal. Adjacent parts have sharp edges.

Step 5. Plant your feet firmly with good balance to receive a heavy weight.

Step 6. Slide the power supply toward you. Slightly tilt the chassis toward you and reach the left hand over the top to balance the chassis on the cabinet rails. Press the chassis firmly against the rails or the chassis will suddenly slide out of the cabinet. See Figure 5.

Step 7. Reposition the left hand from balancing the chassis to a firm grip.

Step 8. Brace your body to receive a heavy weight, and lift the power supply chassis free of the cabinet.

**5.5 BATTERY MAINTENANCE**

The battery or batteries used for emergency power require certain routine maintenance procedures to assure long trouble-free operation. Persons servicing the batteries should refer to the manufacturer's recommendations for routine maintenance. In addition, certain maintenance procedures are appropriate following each interval of emergency power operation.

Routine battery maintenance procedures for the two most common battery types are given (nickel-cadmium and lead-acid). The importance of keeping good battery maintenance records cannot be overemphasized. A chart or table is needed, listing all voltage readings, temperature and hydrometer readings (where applicable), versus the dates on which the readings were taken. To be most effective, the battery report charts should be kept at the battery location for ready reference.

**5.5.1 Nickel-Cadmium Batteries**

Perform the following routine maintenance procedures at six-month intervals.

Step 1. Clean the battery and inspect it for damage.

Step 2. Measure cell voltages and enter the voltage readings on your maintenance report.

Most maintenance schedules require voltage readings of every cell each time maintenance is performed. If a difference of .05 volt or more exists between any two cells, apply an "equalizing charge" to the battery for 48 hours or until three consecutive cell measurements show no change (readings to be taken at 1/2-hour intervals). The terminal voltage of the battery should then read 15.25 ± 0.2 volts.

Step 3. Add water as required to keep the electrolyte solution in each cell above minimum. Use *distilled water only*. Check the battery manufacturer's service literature for instructions on filling.

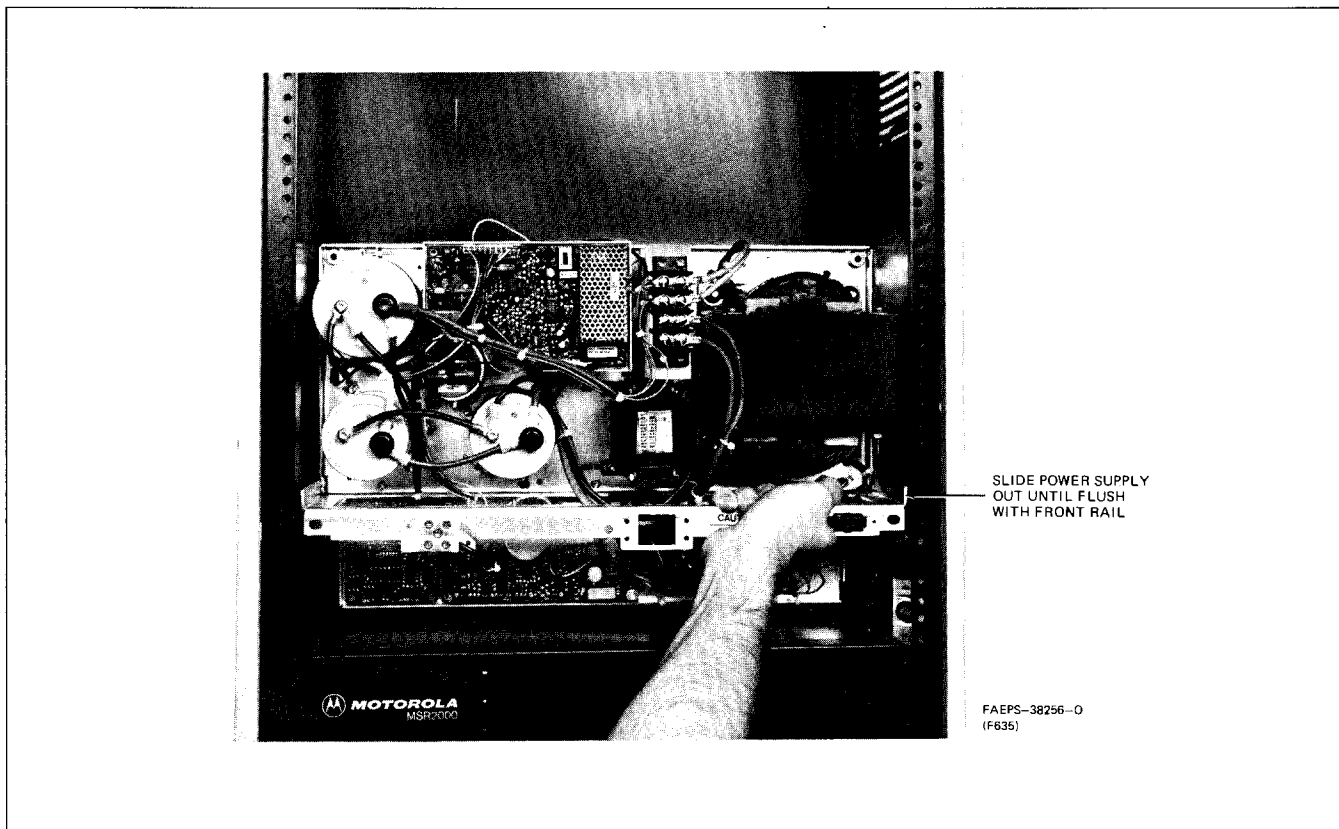

Figure 3. Power Supply Chassis Travel Distance

**CAUTION**

Do not use any tool on a nickel-cadmium battery which may have been used with lead-acid batteries. To do so may destroy the nickel-cadmium battery due to chemical contamination by electrolyte or other foreign matter from the lead-acid battery existing on the tool in question.

If frequent replacement of water is required, the charging rate may be too high. In this case, carefully check the A+ voltage with the switch in the FLOAT position for the specified 14.25 volts. Under certain high ambient temperature conditions, the battery may require water even though the charging voltage is correct. In this case, the charging voltage should be reduced until infrequent addition of water is required.

**5.5.2 Lead-Acid Batteries**

Perform the routine maintenance procedures monthly.

Step 1. Clean the battery and inspect it for damage.

Step 2. Measure cell voltages and enter the voltage readings on your maintenance report. Most maintenance schedules require voltage readings of every cell each time maintenance is performed. If a difference of .05 volt or more exists between any two cells, apply an "equalizing charge" to the battery for the number of hours recommended by the manufacturer.

Step 3. Take specific gravity readings with a hydrometer calibrated for the type of electrolyte used.

Step 4. Observe the necessary precautions to see that the readings are accurate, that no chemical contamination of the cells occurs, and to prevent bodily injury from contact with the electrolyte.

Step 5. After taking a reading, always return the electrolyte in the hydrometer syringe to the cell from which it came. (Failure to do so will decrease the specific gravity of the cell when water is added to fill up the cell.)

Step 6. For an accurate comparison with "standard" specific gravity readings, as published in manufacturer's specifications, a correction factor must be applied to all readings to normalize them with the standard values, when taken at temperatures other than 77 + Fahrenheit. However, if the battery temperature tends to be the

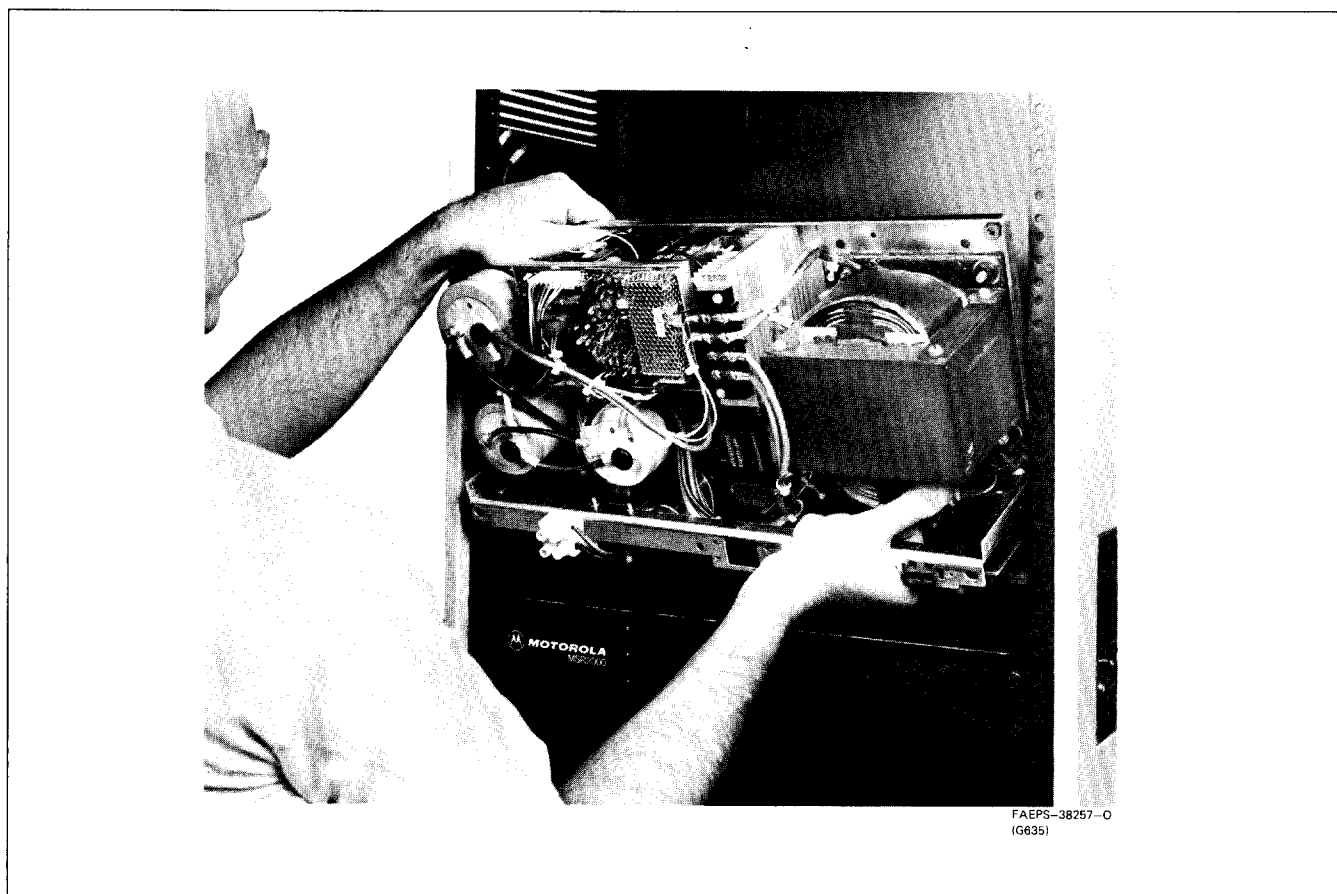

Figure 4. Properly Gripped Chassis

same each time specific gravity readings are taken, a trend toward a change in specific gravity will be apparent without having to apply the correction factor to the readings.

The correction factor is easily applied, due to a linear relationship between changes in temperature and specific gravity above and below 77 + F. For each three degrees above 77 + F, add .001 (known as "1 point") to the "standard" value of specific gravity. Conversely, for each three degrees below 77 + F, subtract 1 point.

Step 7. Take a specific gravity reading of the "pilot cell" monthly. It is not necessary to continually check the specific gravity of all cells, because any gradual changes usually occur simultaneously in all cells. One cell is therefore chosen and designated the "pilot cell," and the monthly routine specific gravity readings are always taken from this one cell. (Be sure to indicate on the maintenance chart which cell is the pilot cell.)

Take specific gravity readings of all the battery cells every three months, and record them on the maintenance chart.

Step 8. Add water as required to keep the electrolyte solution in each cell up to a minimum level. In some batteries, the electrolyte level should be between the high and low-level marks on the inside of each cell. If the cells have no such markers, check the manufacturer's literature. Use *distilled water only*.

#### CAUTION

Do not use any tool on a lead-acid battery which may have been used with nickel-cadmium batteries. To do so may destroy the lead-acid battery, due to chemical contamination by electrolyte or other foreign matter from the nickel-cadmium battery existing on the surface of the tool in question.

If frequent replacement of water is required, the charging rate may be too high. In this case, carefully check the A+ voltage for the specified 13.0 volts with the switch in the FLOAT position. Under certain high ambient temperature conditions, the battery may require fre-

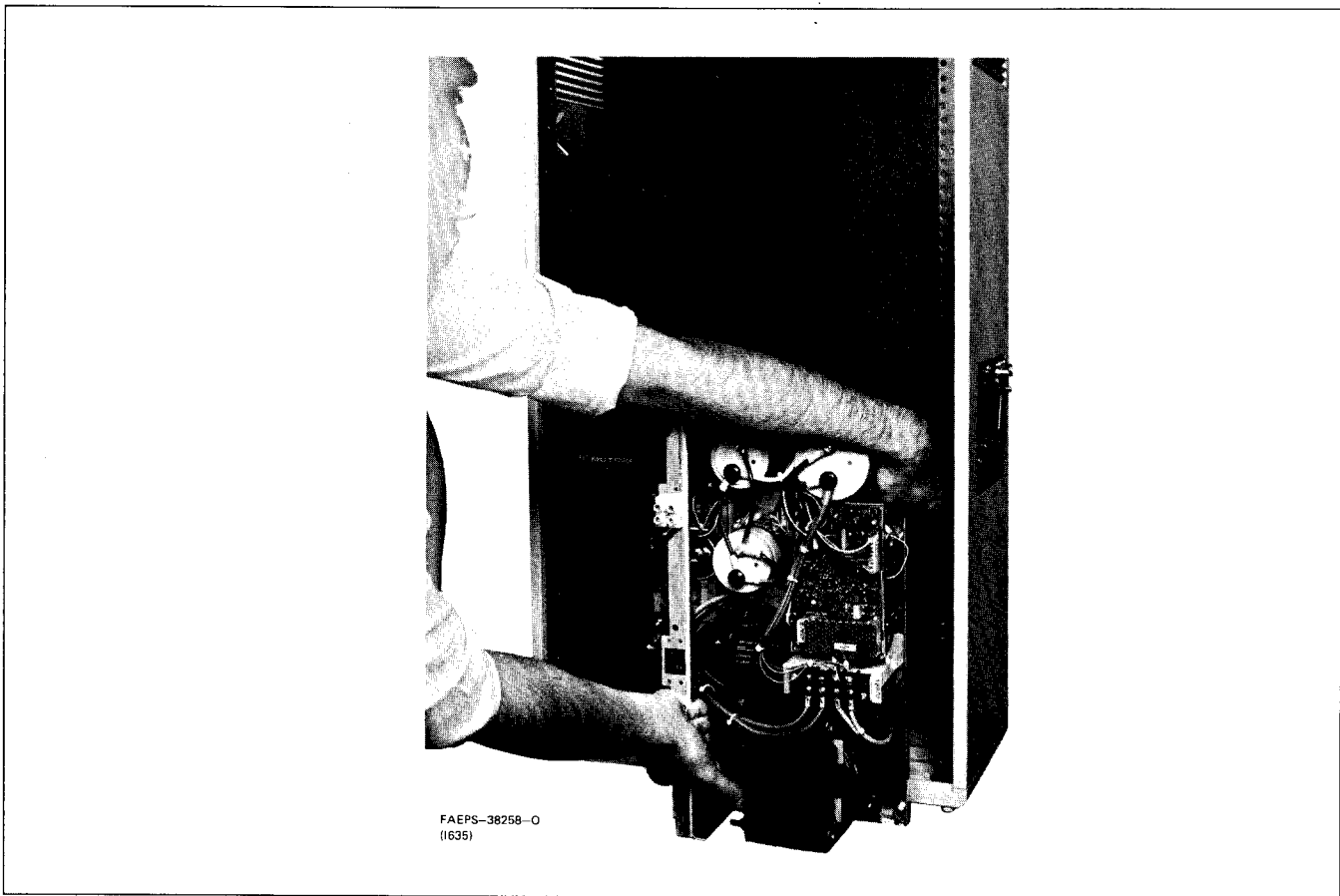

Figure 5. Power Supply Removed From Cabinet

quent water replacement even though the correct charging voltage is maintained. In this case, the specified 13.0 volts may be reduced until infrequent addition is required.

Step 9. Equalize charging of a lead-acid battery should be performed under any one of the following conditions:

- following each known use (or discharge) of the battery,
- if the specific gravity of the pilot cell or any other cell is more than ten-thousandths (10 points) below its full-charge value,
- if the difference in voltage between any two cells is .05 volt or more,
- as part of each monthly routine maintenance procedure independent of any of the previous conditions stated.

Equalize charging should continue for: (a) the number of hours specified by the battery manufacturer, which

will vary according to temperature, charging voltage and the manufacturer's recommendations or; (b) until three successive readings of cell voltage and specific gravity show *no change* (readings to be taken at 1/2-hour intervals).

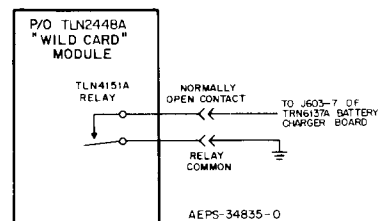

Figure 6. Remote Control of Float-Equalize

### 5.5.3 Remote Control

Equalize charging may be remotely controlled in tone remote control base and repeater stations. This can be accomplished with a TLN2448A "Wild Card" Module and a TLN4151A Relay as shown in Figure 6. Leave the FLOAT-EQUALIZE switch in the FLOAT position.

*Table 3. Troubleshooting Chart*

| Symptom  | Action   |
|--|--|
| A. No Output Voltage   | <ol style="list-style-type: none"> <li>1. Check primary line connection to supply.</li> <li>2. Check for transformer secondary voltage at TB602.</li> <li>3. Check for continuity through relay.</li> </ol>  |
| B. Relay pulls in when power is applied.   | <ol style="list-style-type: none"> <li>1. Check for trigger pulses at pin 8, U650C.                     <ol style="list-style-type: none"> <li>a) If no trigger is present, check for proper signals from RAMP GEN. back to CLOCK GEN. If proper signals are present, check voltages at STABILIZER and CONTROL VOLTAGE GEN.</li> <li>b) If correct trigger pulses are present, check power switching circuitry (Q656 through Q657).</li> </ol> </li> <li>2. Check OVERVOLTAGE COMPARATOR and ACTIVITY DETECTOR for proper levels.</li> <li>3. Check RELAY DRIVER and RELAY LATCH transistors (Q654 and Q660).</li> </ol> |
| C. A+ output voltage too high and cannot adjust.   | <p>Check for trigger pulses at pin 8, U650C.</p> <ol style="list-style-type: none"> <li>1. If no trigger present, check for proper signals from RAMP GEN. back to CLOCK GEN. If proper signals are present, check voltages at STABILIZER and CONTROL VOLTAGE GEN.</li> <li>2. If correct trigger pulses are present, check power switching circuitry (Q656 through Q657).</li> </ol>   |
| D. A+ output voltage too low.  | <ol style="list-style-type: none"> <li>1. Check for trigger pulses at pin 8, U650C.                     <ol style="list-style-type: none"> <li>a) If no trigger present, check for proper signals from RAMP GEN. back to CLOCK GEN. If proper signals are present, check voltages at STABILIZER and CONTROL VOLTAGE GEN.</li> <li>b) If correct trigger pulses are present, check power switching circuitry (Q656 through Q657).</li> </ol> </li> <li>2. Check power diodes CR601, CR602.</li> </ol>   |
| E. No regulated output voltage.  | <ol style="list-style-type: none"> <li>1. Check for approximately 14 volts at J1-1. If no voltage, check fuse F603.</li> <li>2. Check for approximately 6.5 volts at TP105, 6.55 V REF. If no voltage, check CR2 and VR1.</li> <li>3. Check for grounded CR4 and CR8, REGULATOR INHIBIT lead.</li> <li>4. Check for defective U1B.</li> <li>5. Check for defective U1D.</li> </ol>   |
| F. 9.4 V regulated output: OK. No 14 V regulated output.                                 | <ol style="list-style-type: none"> <li>1. Check fuses F605 and F604.</li> <li>2. Check Q3 and Q4. TP105 should be 6.5 volts.</li> <li>3. Check U1C.</li> <li>4. Check Q2 for open circuit.</li> <li>5. Check Q1 and Q11 for open circuit.</li> <li>6. Check VR2 for short.</li> <li>7. Check for short circuit at J5-2.</li> </ol>   |
| G. 14 V regulated output: OK. No 9.4 V regulated output.                                 | <ol style="list-style-type: none"> <li>1. Check Q8 and Q9. TP104 should be 6.5 volts.</li> <li>2. Check U1A.</li> <li>3. Check Q7 for open circuit.</li> <li>4. Check Q6 for open circuit.</li> <li>5. Check VR3 for short circuit.</li> <li>6. Check for short circuit at J5-6.</li> </ol>  |
| H. Regulators cannot supply full rated current of 1.5A (output drops more than 1 volt).  | <ol style="list-style-type: none"> <li>1. Check U1D, Q3, Q4, Q8 and Q9.</li> </ol>   |
| I. Short circuit current greater than 0.8A, and possibly input fuse blowing.             | <ol style="list-style-type: none"> <li>1. Overcurrent detect circuits defective. Check U1D, Q3, Q4, Q8, and Q9.</li> <li>2. Check CR5 and CR10.</li> </ol>   |
| J. Regulated output voltages cannot be adjusted to $9.4 \pm 0.1$ V and $13.9 \pm 0.1$ V. | <ol style="list-style-type: none"> <li>1. Check 6.5 V REF. It should be <math>6.5 \pm 0.2</math> volts. If not, check CR2, VR1, and VR4.</li> <li>2. Check regulator feedback loop: U1A, Q7, and Q6; U1C, Q2, Q1, and Q11.</li> <li>3. Check for high leakage Q2 and Q7.</li> </ol>  |
| K. High ac ripple voltage on 14 V regulated output: greater than 10 mV at 1.5A.          | <ol style="list-style-type: none"> <li>1. Check filter capacitor C1 for low capacity or leakage. Ripple voltage at TP100 is greater than 4 V peak-to-peak.</li> <li>2. Check U1C for low loop gain: less than 20 dB.</li> </ol>  |
| L. Voltage switched from 14 V out to main 13.8 V.  | <ol style="list-style-type: none"> <li>1. Check relay K100.</li> <li>2. Check Q101 thru Q104.</li> <li>3. Check ferroresonant controller and fuses.</li> <li>4. Check ac power.</li> </ol>   |
| M. Regulator inhibit low and regulators shut down.                                       | <ol style="list-style-type: none"> <li>1. Check Q105.</li> <li>2. Check U100A.</li> <li>3. Check Q101 and Q102.</li> <li>4. Check battery voltage.</li> </ol>  |
| N. Continuous tone out.  | <ol style="list-style-type: none"> <li>1. Check U100A, B and D.</li> <li>2. Check battery voltage.</li> <li>3. Check ferroresonant controller.</li> </ol>  |
| O. Pulsed tone out.  | <ol style="list-style-type: none"> <li>1. If AC FAIL is low, check primary circuits and fuses.</li> <li>2. If AC FAIL is not low, check Q102, CR109, and Q101.</li> </ol>  |
| P. AC FAIL or 0 V ALARM low, and no tone.  | <ol style="list-style-type: none"> <li>1. If no tone at TP103, check U100C, Q102, R120, R139, phase shift network and U100C.</li> <li>2. If there is a tone at TP103 and JU102 is in, readjust R128.</li> </ol>  |

# parts list

TRN5299A Chassis PL-8013-O

| REFERENCE SYMBOL        | MOTOROLA PART NO. | DESCRIPTION  |
|-------------------------|-------------------|--|
| Q1,6,11                 | 48-869672         | <b>diode: (see note)</b><br>PNP, type M9672  |
| P3                      | 15-83498F39       | <b>connector:</b><br>HOUSING, 3 position (WHT)<br>HOUSING, 3 position (RED)<br>HOUSING, 3 position (WHT) |
| P4                      | 15-83498F40       |  |
| P7                      | 15-83498F39       |  |
| <b>mechanical parts</b> |                   |  |
| 3-136143                |                   | SCREW, tapping: 8-32 x 1/4"; 6 used  |
| 43-83561N01             |                   | STANDOFF, twist lock; 2 used   |
| 3-136850                |                   | SCREW, tapping: 6-32 x 1/2"; 6 used  |
| 9-82973A01              |                   | SOCKET, transistor; 3 used   |
| 14-865854               |                   | INSULATOR; 3 used  |
| 26-82979N01             |                   | HEAT SINK; 3 used  |
| 29-83499F01             |                   | TERMINAL; 9 used   |

**note:** For optimum performance, diodes, transistors, and integrated circuits must be ordered by Motorola part numbers.

TRN5297A Hardware Kit PL-8014-O  
TRN5298A Hardware Kit

| REFERENCE SYMBOL        | MOTOROLA PART NO. | DESCRIPTION                                    |
|-------------------------|-------------------|--|
| P6,101                  | 15-83498F38       | <b>connector:</b><br>HOUSING, 2 position       |
| <b>mechanical parts</b> |                   |  |
| 3-134185                |                   | SCREW, tapping: 6-32 x 1/4"                    |
| 43-82980N01             |                   | STANDOFF; 3 used TRN5297A; 5 used TRN5298A     |
| 43-82980N02             |                   | STANDOFF, spacer; 2 used TRN5298A              |
| 43-83561N01             |                   | STANDOFF, twist lock; 2 used                   |
| 1-80754D87              |                   | Assembly Wire and Lug includes: (p/o TRN5297A) |
| 29-83499F01             |                   | TERMINAL; 2 used                               |
| 1-80754D97              |                   | Assembly Wire and Lug includes: (p/o TRN5298A) |
| 29-83499F01             |                   | TERMINAL; 2 used                               |
| 1-80754D98              |                   | Assembly Wire and Lug includes: (p/o TRN5298A) |
| 29-83499F01             |                   | TERMINAL; 2 used                               |
| 42-10217A02             |                   | STRAP, ties                                    |

TRN5362A Interconnect Battery Charger Hardware PL-8016-C

| REFERENCE SYMBOL        | MOTOROLA PART NO. | DESCRIPTION                              |
|-------------------------|-------------------|--|
| P1,603                  | 15-83498F45       | <b>connector:</b><br>HOUSING; 9 position |
| R140                    | 17-83389G02       | <b>resistor:</b><br>30 ohms ± 5%; 20 W   |
| <b>mechanical parts</b> |                   |  |
| 3-83498N04              |                   | SCREW, tapping: M4 x 0.7 x 7mm; 3 used   |
| 46-84549F01             |                   | PLUG, polarizing; 2 used                 |
| 29-83499F01             |                   | TERMINAL; 16 used                        |
| 3-10943M25              |                   | SCREW, tapping M4 x 0.7 x 20mm; 2 used   |
| 29-82907N07             |                   | TERMINAL, ring                           |
| 29-83883C02             |                   | TERMINAL                                 |
| 30-84204N01             |                   | CABLE, 4-conductor; 6.63"                |

TKN8295A Internal Battery Cable Kit PL-8017-E  
TKN8845A Internal Battery Cable Kit (DC Only)

| REFERENCE SYMBOL        | MOTOROLA PART NO.          | DESCRIPTION   |
|-------------------------|----------------------------|---|
| J605                    | 15-83502N01<br>39-83503N02 | <b>connector, receptacle:</b><br>assembly connector, includes:<br>HOUSING, single contact; 2 used<br>CONTACT, battery; 2 used |
| <b>mechanical parts</b> |                            |   |
| 7-83504N01              |                            | BRACKET, male mounting  |
| 7-83505N01              |                            | BRACKET, female mounting  |
| 2-10971A18              |                            | NUT, machine: M5 x 0.8; 2 used  |
| 3-83497N02              |                            | SCREW, machine: M5 x 0.8 x 12 mm; 2 used  |
| 4-7658                  |                            | WASHER, lock: #10 internal; 2 used  |
| 42-10217A02             |                            | STRAP, tie: .091 x 3.62; 3 used   |

TRN5153A Battery Charger P.S. Hardware Kit PL-8018-C

| REFERENCE SYMBOL        | MOTOROLA PART NO. | DESCRIPTION                                    |
|-------------------------|-------------------|--|
| L650                    | 25-82419N05       | <b>coil, rf:</b><br>65 mh                      |
| P606                    | 15-83142M08       | <b>connector, plug:</b><br>HOUSING, 4 position |
| K650                    | 80-83013N01       | <b>relay:</b><br>1 form "C"; coil res, 70 ohms |
| <b>mechanical parts</b> |                   |  |
| 2-10971A17              |                   | NUT, machine: M4 x 0.7 hex                     |
| 3-83497N03              |                   | SCREW, machine                                 |
| 3-83497N02              |                   | SCREW, machine: M5 x 0.8 x 12mm                |
| 3-83498N04              |                   | SCREW, tapping: M4 x 0.7 x 7mm; 4 used         |
| 3-83498N06              |                   | SCREW, tapping: M4 x 0.7 x 16mm; 2 used        |
| 4-7651                  |                   | LOCKWASHER: #8 internal; 3 used                |
| 5-82904N02              |                   | GROMMET, transformer; 4 used                   |
| 7-83364N01              |                   | BRACKET, charger board                         |
| 15-83901N01             |                   | COVER, battery; option, board                  |
| 29-82907N02             |                   | TERMINAL, ring; 2 used                         |
| 29-83113N03             |                   | TERMINAL, right angle; 2 used                  |
| 39-82717M01             |                   | CONTACT, receptacle; 4 used                    |
| 39-83503N02             |                   | CONTACT, battery connector; 2 used             |
| 2-10971A18              |                   | NUT; M5 x 0.8                                  |
| 4-7658                  |                   | LOCKWASHER: #10 internal                       |
| 14-83986N01             |                   | INSULATOR                                      |
| 29-82907N05             |                   | TERMINAL, ring; 10 ga.; 2 used                 |
| 43-82980N03             |                   | STANDOFF; 6 used                               |
| 42-10217A02             |                   | STRAP, tie: nylon                              |
| 54-83971N01             |                   | LABEL  |

TRN5155A External Battery Cable Kit PL-8059-C

| REFERENCE SYMBOL        | MOTOROLA PART NO.          | DESCRIPTION   |
|-------------------------|----------------------------|---|
| F610                    | 65-82846N01                | <b>fuse:</b><br>60 amp; 300 V   |
| P605                    | 15-83502N01<br>39-83503N02 | <b>connector, plug:</b><br>assembly connector, includes:<br>HOUSING, single contact; 2 used<br>CONTACT, battery; 2 used |
| <b>mechanical parts</b> |                            |   |
| 3-138490                |                            | SCREW, tapping: 8-18 x 1 1/4"; 2 used   |
| 9-82842N01              |                            | BLOCK, fuse   |
| 29-847817               |                            | LUG, ring tongue; 2 used  |
| 42-10217A02             |                            | STRAP, tie; 3 used  |

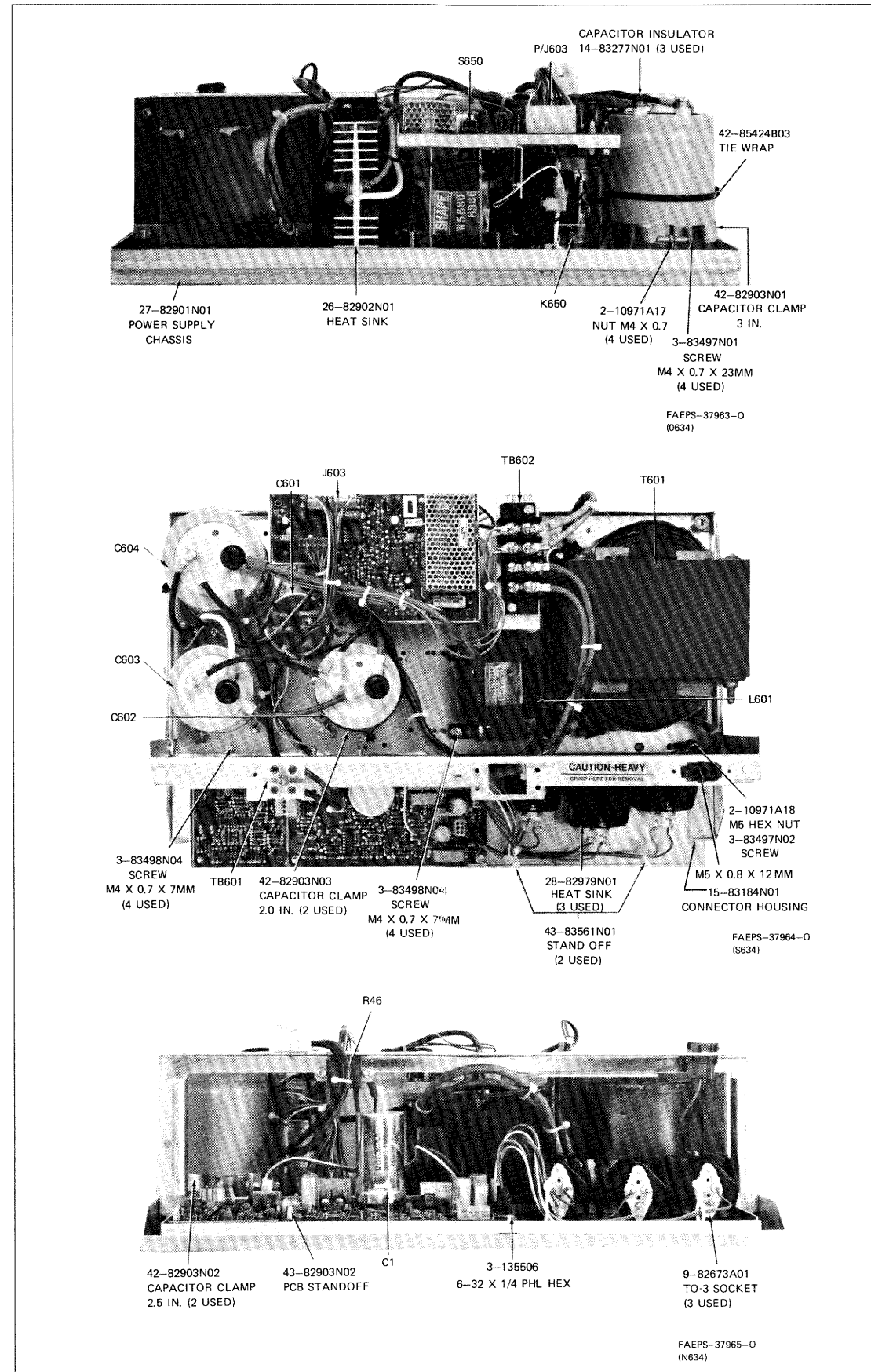

# PARTS LISTS AND LOCATION



# OPTION C28AN BATTERY CHARGER POWER SUPPLY FUNCTIONAL BLOCK DIAGRAM

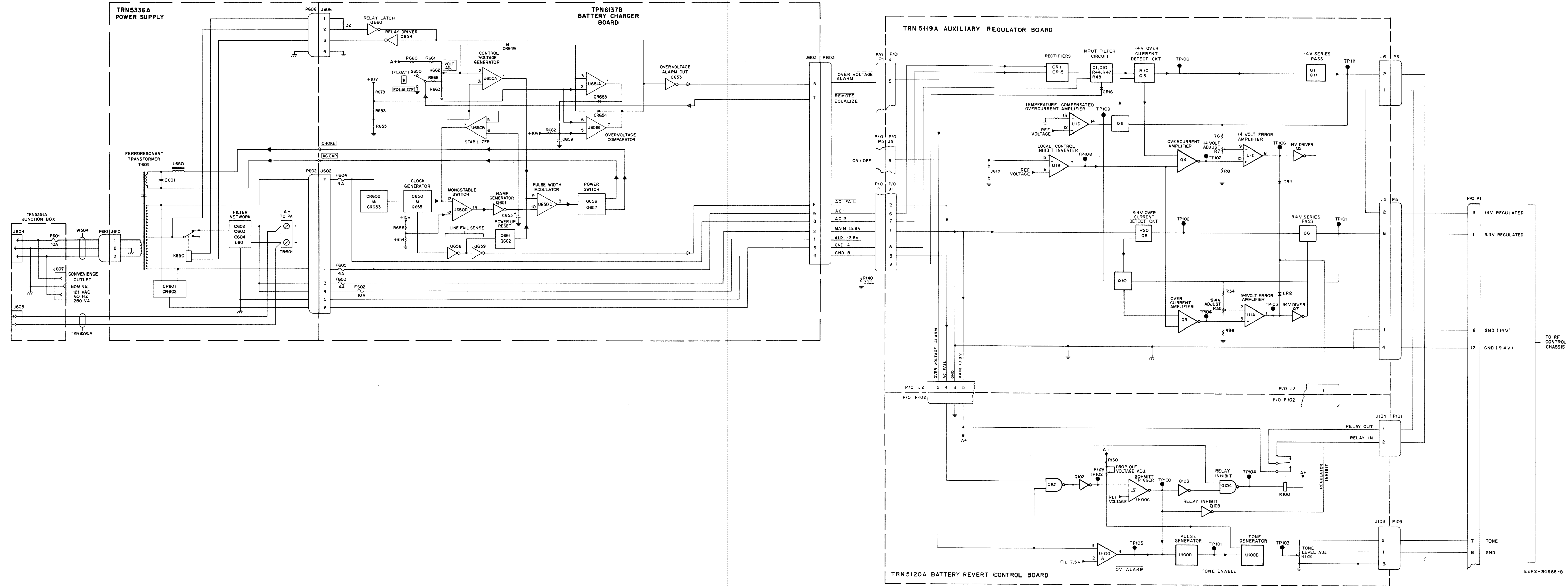

EEPS-34688-B

# OPTION C28AN BATTERY CHARGER POWER SUPPLY

MODEL TPN1192A

## parts list

TPN6137B Battery Charger Circuit Board PL-8495-A

| REFERENCE SYMBOL | MOTOROLA PART NO. | DESCRIPTION  |
|------------------|-------------------|--|
| C649             | 21-82372C05       | capacitor, fixed: $\mu\text{F} \pm 20\%$ ; 25 V; unless otherwise stated |
| C650             | 8-84637L34        | 0.2 + 80-20%   |
| C651             | 8-11017A09        | 33 $\pm 10\%$ ; 50 V   |
| C653             | 8-11017A10        | 0.15 $\pm 5\%$ ; 50 V  |
| C654             | 23-11019A40       | 0.18 $\pm 5\%$ ; 50 V  |
| C655             | 8-82860N01        | 47   |
| C656, 657, 658   | 21-11014H32       | 0.47 $\pm 10\%$ ; 250 V  |
| C659             | 23-11019A40       | 20 pF $\pm 5\%$ ; 100 V  |
| C660             | 23-11019A11       | 47 $\pm 10\%$  |
| C661, 662        | 23-11019A48       | 2.2; 50 V  |
| C663 thru 667    | 21-11014H32       | 220; 10 V  |
| C668             | 21-83596E20       | 20 pF $\pm 5\%$ ; 100 V  |
| C669             | 21-11014H32       | 0.1 $\pm 20\%$ ; 1000 V  |
| C670             | 21-11014H32       | 20 pF $\pm 5\%$ ; 100 V  |
| C671             | 8-84637L22        | NOT USED   |
| C672             | 21-11014H32       | 22 $\pm 10\%$ ; 100 V  |
| C673             | 23-11019A46       | 20 pF $\pm 5\%$ ; 100 V  |
| C674, 675, 676   | 21-11014H32       | 100 $\pm 20\%$ ; 25 V  |
| CR646 thru 649   | 48-11034D01       | silicon  |
| CR650, 651       | 48-82466H18       | silicon  |
| CR652, 653       | 48-82466H13       | silicon  |
| CR654, 655       | 48-11034D01       | silicon  |
| CR656, 657       | 48-82466H18       | silicon  |
| CR658, 659       | 48-11034D01       | silicon  |
| CR660            | 48-82466H18       | silicon  |
| CR661            | 48-11034D01       | silicon  |
| CR662            | 48-83854H01       | silicon  |
| CR663, 664, 665  | 48-11034D01       | silicon  |
| CR668, 669, 670  | 48-11034D01       | silicon  |
| DS604            | 48-84404E04       | light emitting diode: (see note) green                                   |
| F602             | 65-139767         | fuse: 10 amp; 32 V   |
| F603, 604, 605   | 65-82859N01       | 4 amp; 32 V  |
| J602             | 28-82984N06       | connector, plug: male; 6-contact   |
| J603             | 28-82984N10       | male; 9-contact  |
| J606             | 28-83143M05       | male; 4-contact  |
| Q650             | 48-869643         | transistor: (see note) PNP; type M9643                                   |
| Q651             | 48-869642         | NPN; type M9642  |
| Q653             | 48-869642         | NPN; type M9642  |
| Q654             | 48-869648         | NPN; type M9648  |
| Q655             | 48-869643         | PNP; type M9643  |
| Q656             | 48-82604N01       | silicon controlled rectifier   |
| Q657             | 48-82965F02       | TRIAC; 15 amp; 800 V   |
| Q658             | 48-869642         | NPN; type M9642  |
| Q659             | 48-869528         | NPN; type M9528  |
| Q660             | 48-869643         | PNP; type M9643  |
| Q661, 662        | 48-869642         | NPN; type M9642  |
| R609             | 6-125C51          | resistor, fixed: $\pm 5\%$ ; 1/4 W; unless otherwise stated              |
| R640, 641        | 6-11009E49        | 1.2k $\pm 10\%$ ; 1/2 W  |
| R642             | 6-125A33          | 1k   |
| R648             | 6-11009E89        | 220; 1/2 W   |
| R649             | 6-11009E81        | 47k  |
| R650             | 6-11009E56        | 3.3k   |
| R651             | 6-11009E63        | 2k   |
| R652             | 6-11009E60        | 3.9k   |
| R653             | 6-125A31          | 3k   |
| R655             | 6-125A31          | 180; 1/2 W   |
| R656             | 6-84640C25        | 2.1k $\pm 1\%$   |
| R657             | 6-11009E56        | 2k   |
| R658             | 6-125C35          | 270; 1/2 W   |
| R659             | 6-11009F12        | 390k   |
| R660             | 6-11009F08        | 270k   |
| R661             | 6-11009E57        | 2.2k   |
| R662             | 18-82374N10       | 5.6k   |
| R663             | 6-11009E61        | variable: 1k; 0.25 W   |
| R664             | 6-11009E63        | 3.3k   |
| R665             | 6-11009E63        | 3.9k   |
| R666             | 6-11009E53        | 3k   |
| R667             | 6-11009F10        | 1.5k   |
| R668             | 6-11009E83        | 330k   |
| R669             | 6-11009E89        | 27k  |
| R670             | 6-11009E89        | 47k  |
| R672             | 6-11009E55        | 1.8k   |
| R673             | 6-11009E49        | 1k   |
| R674             | 6-125C59          | 2.7k $\pm 10\%$ ; 1/2 W  |
| R675             | 6-11009E29        | 150  |
| R676             | 6-126A49          | 1k; 1 W, 5%  |
| R677             | 6-11009E65        | 4.7k   |
| R678             | 6-11009E89        | 47k  |
| R679             | 6-11009E55        | 1.8k   |
| R680             | 6-11009E44        | 620  |
| R681             | 6-125A45          | 680; 1/2 W, 5%   |
| R682             | 6-11009E53        | 1.5k   |

| REFERENCE SYMBOL | MOTOROLA PART NO.                 | DESCRIPTION   |
|------------------|-----------------------------------|---|
| R682             | 6-11009E95                        | 82k   |
| R683             | 6-11009E35                        | 270   |
| R684             | 6-11009E57                        | 2k  |
| R686             | 6-11009E73                        | 10k   |
| R690             | 6-11009E33                        | 220   |
| R691             | 6-11009E37                        | 330   |
| R692             | 6-11009E56                        | 2k  |
| R693             | 6-11009E65                        | 4.7k  |
| R694             | 6-11009E53                        | 1.5k  |
| R695             | 6-11009E65                        | 4.7k  |
| R696             | 17-82177B02                       | 32; 5 W   |
| R697             | 6-11009E49                        | 1k  |
| R698             | 6-11009E81                        | 22k   |
| R699             | 6-11009E89                        | 47k   |
| RT650            | 6-82769A08                        | thermistor: 2.02k @ 25°C                                  |
| S650             | 40-83204B02                       | switch: dpdt  |
| U650             | 51-83629M58                       | integrated circuit: (see note) quad operational amplifier |
| U651             | 51-83629M77                       | dual operational amplifier                                |
| VR650            | 48-82256C56                       | voltage regulator: Zener; 8.8 V                           |
| VR651            | 48-82256C25                       | Zener; 12 V   |
| VR652            | 48-83461E40                       | Zener; 5.1 V  |
| VR653            | 48-82256C63                       | Zener; 17 V   |
| VR654, 655       | 48-83461E30                       | Zener; 6.2 V  |
| 2-10971A16       | NUT, M3-0.5                       | mechanical parts  |
| 3-83497N04       | SCREW, machine: M3 x 0.5 x 8mm    |   |
| 4-7683           | LOCKWASHER, #4 internal           |   |
| 14-83820M02      | INSULATOR, transistor             |   |
| 26-84275L01      | HEAT SINK                         |   |
| 29-82906N01      | TERMINAL, blade fuse; 8 used      |   |
| 29-10231A10      | TERMINAL, mounting faston; 2 used |   |
| 29-82607B09      | LUG, ring tongue; 2 used          |   |
| 29-82607B05      | LUG, ring tongue; 4 used          |   |
| 29-82907N05      | TERMINAL, ring (YEL) 6 used       |   |
| 29-82907N07      | TERMINAL, ring (RED) 2 used       |   |
| 29-83113N01      | TERMINAL, right angle; 6 used     |   |
| 29-83137N01      | TERMINAL, splice; 2 used          |   |
| 39-83146N01      | CONTACT, socket                   |   |
| 42-85238         | CLAMP, cable; 2 used              |   |
| 42-10217A02      | STRAP, tie; 0.91 x 3.62; 16 used  |   |
| 42-35424B03      | STRAP, tie; .094 x 1.4; 3 used    |   |
| 42-82903N01      | CLAMP, cap; 2"                    |   |
| 42-82903N02      | CLAMP, cap; 2 1/2"; 2 used        |   |
| 42-82903N03      | CLAMP, cap; 3"                    |   |
| 29-82907N06      | TERMINAL, ring (BLU)              |   |
| 54-83971N01      | LABEL; 2 used                     |   |
| 54-84046N01      | LABEL                             |   |
| 75-83056P01      | PAD, snap-on                      |   |
| 31-811350        | TERMINAL, board; 4 terminal       |   |

TRN5336A Power Supply Hardware Kit (500 W) PL-8020-C

| REFERENCE SYMBOL | MOTOROLA PART NO.                       | DESCRIPTION  |
|------------------|---|--|
| C6501            | 8-82682N01                              | capacitor, fixed: 20 $\mu\text{F} \pm 6\%$ ; 330 V |
| C6502, 603       | 23-82681N01                             | 64,000 $\mu\text{F} + 75-7\%$ ; 20 V               |
| C6504            | 23-82681N02                             | 120,000 $\mu\text{F} + 75-10\%$ ; 20 V             |
| C6501, 602       | 48-82732C09                             | diode: (see note) silicon                          |
| F6502            | 9-83360N01                              | connector, receptacle: female; 6 contact           |
| L6501            | 25-82686N01                             | coil: choke; 420 $\mu\text{H}$                     |
| T6501            | 25-82253N01                             | transformer: power: 500 W, 60 Hz                   |
| T6501            | 31-83576K02                             | terminal, board: 2-terminals                       |
| 2-10971A17       | NUT, machine: M4 x 0.7 hex; 4 used      | mechanical parts                                   |
| 3-10907A55       | SCREW, machine: M6 x 1 x 25mm; 4 used   |  |
| 3-83497N01       | SCREW, machine: M4 x 0.7 x 25mm; 4 used |  |
| 3-83498N04       | SCREW, tapping: M4 x 0.7 x 7mm; 18 used |  |
| 3-83498N06       | SCREW, tapping: M4 x 0.7 x 16mm; 3 used |  |
| 3-83678N02       | SCREW, tapping: M3 x 0.5 x 5mm          |  |
| 4-7651           | LOCKWASHER, #8 internal; 12 used        |  |
| 4-83499N01       | WASHER, insulator; 3 used               |  |
| 4-7658           | LOCKWASHER, #10 internal; 25 used       |  |
| 5-82904N01       | GROMMET; 4 used                         |  |
| 14-83277N01      | INSULATOR, lug; 3 used                  |  |
| 14-84088N01      | INSULATOR, cap terminals; 2 used        |  |
| 14-84548A01      | INSULATOR, washer; 2 used               |  |
| 26-82902N01      | HEAT SINK                               |  |
| 29-82607B09      | LUG, ring tongue; 2 used                |  |
| 29-82607B05      | LUG, ring tongue; 4 used                |  |
| 29-82907N05      | TERMINAL, ring (YEL) 6 used             |  |
| 29-82907N07      | TERMINAL, ring (RED) 2 used             |  |
| 29-83113N01      | TERMINAL, right angle; 6 used           |  |
| 29-83137N01      | TERMINAL, splice; 2 used                |  |
| 39-83146N01      | CONTACT, socket                         |  |
| 42-85238         | CLAMP, cable; 2 used                    |  |
| 42-10217A02      | STRAP, tie; 0.91 x 3.62; 16 used        |  |
| 42-35424B03      | STRAP, tie; .094 x 1.4; 3 used          |  |
| 42-82903N01      | CLAMP, cap; 2"                          |  |
| 42-82903N02      | CLAMP, cap; 2 1/2"; 2 used              |  |
| 42-82903N03      | CLAMP, cap; 3"                          |  |
| 29-82907N06      | TERMINAL, ring (BLU)                    |  |
| 54-83971N01      | LABEL; 2 used                           |  |
| 54-84046N01      | LABEL                                   |  |
| 75-83056P01      | PAD, snap-on                            |  |
| 31-811350        | TERMINAL, board; 4 terminal             |  |

note: For optimum performance, diodes, transistors, and integrated circuits must be ordered by Motorola part numbers.

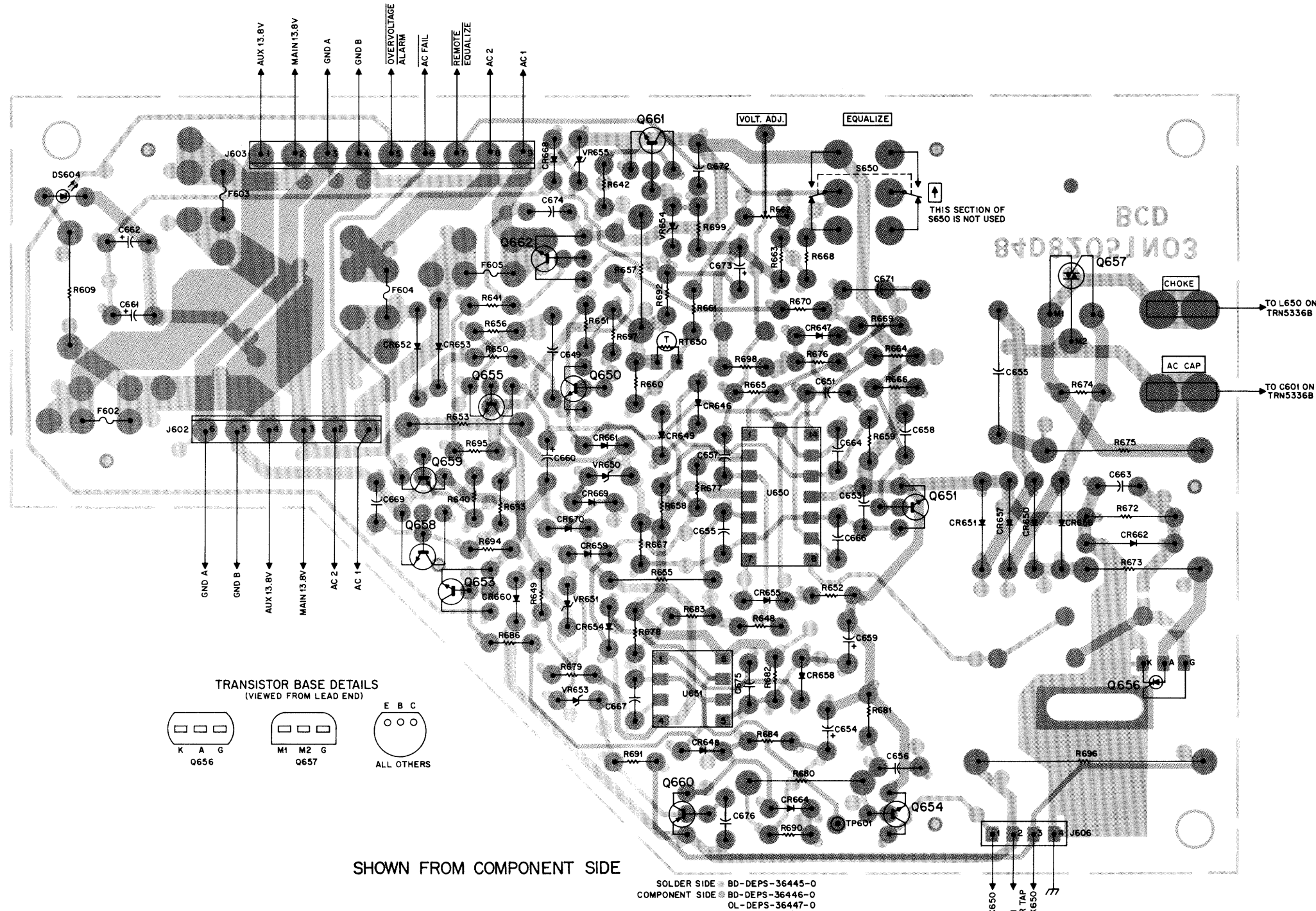

TRN5336A Standard Power Supply, and  
TPN6137B Battery Charger Board  
Schematic Diagram, Circuit Board Detail,  
and Parts Lists  
Motorola No. PEPS-34740-D  
(Sheet 1 of 2)  
9/30/85-UP

**OPTION C28AN**  
**BATTERY CHARGER POWER SUPPLY**  
 MODEL TPN1192A

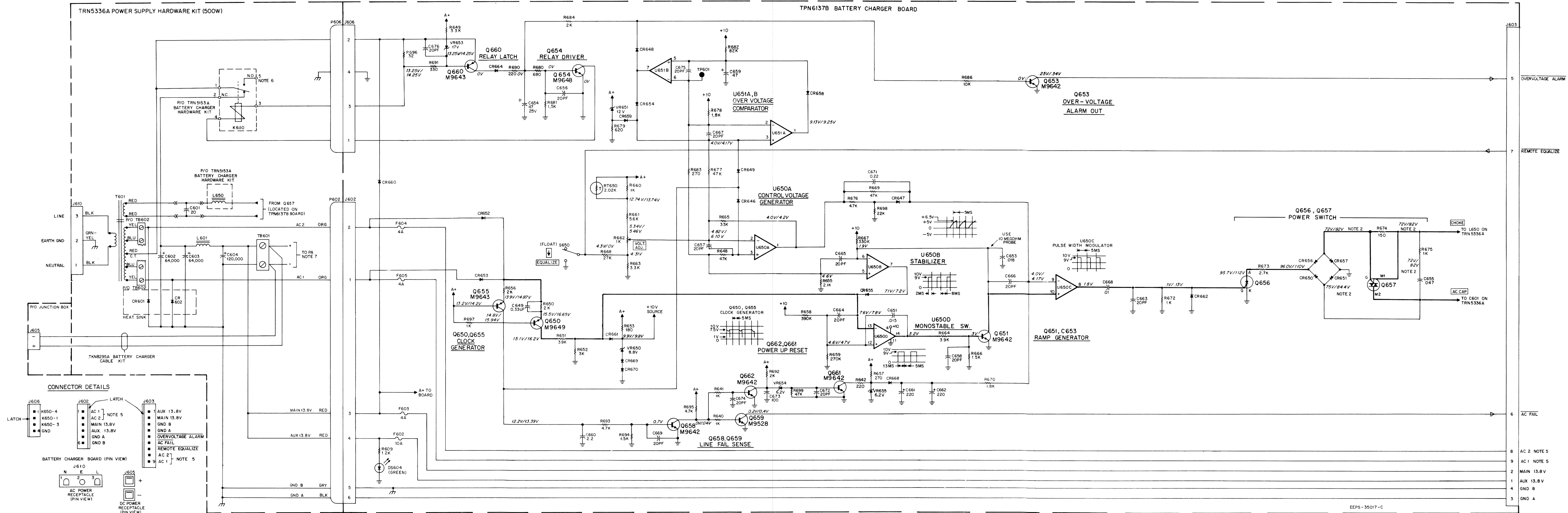

- NOTES:
1. Unless specified otherwise, all capacitor values are in microfarads and resistor values in ohms.
  2. Waveform is non-sinusoidal. Voltage in recorded rms.
  3. Voltages measured with DVM, with 1 meg ohm or greater input impedance.
  4. Voltages measured correspond to SW650 = float position/equalize position, 120 V ac line, 2A load current, with output voltage set to 13.2 V in the float position by R662. Voltage measured @ TB601.
  5. Used in MSR 2000 stations only.
  6. To J1-9 of TRN5119A Auxiliary regulator board in MSR 2000 stations only.
  7. The + and - wires from TB601 connect to TB801 on MSR 2000 stations and directly to the power amplifier on MSF 5000 stations.

TRN5336A Standard Power Supply, and  
 TPN6137B Battery Charger Board  
 Schematic Diagram, Circuit Board Detail,  
 and Parts Lists  
 Motorola No. PEPS-34740-D  
 (Sheet 2 of 2)  
 9/30/85-UP

# OPTION C28AN BATTERY CHARGER POWER SUPPLY MODEL TPN1192A

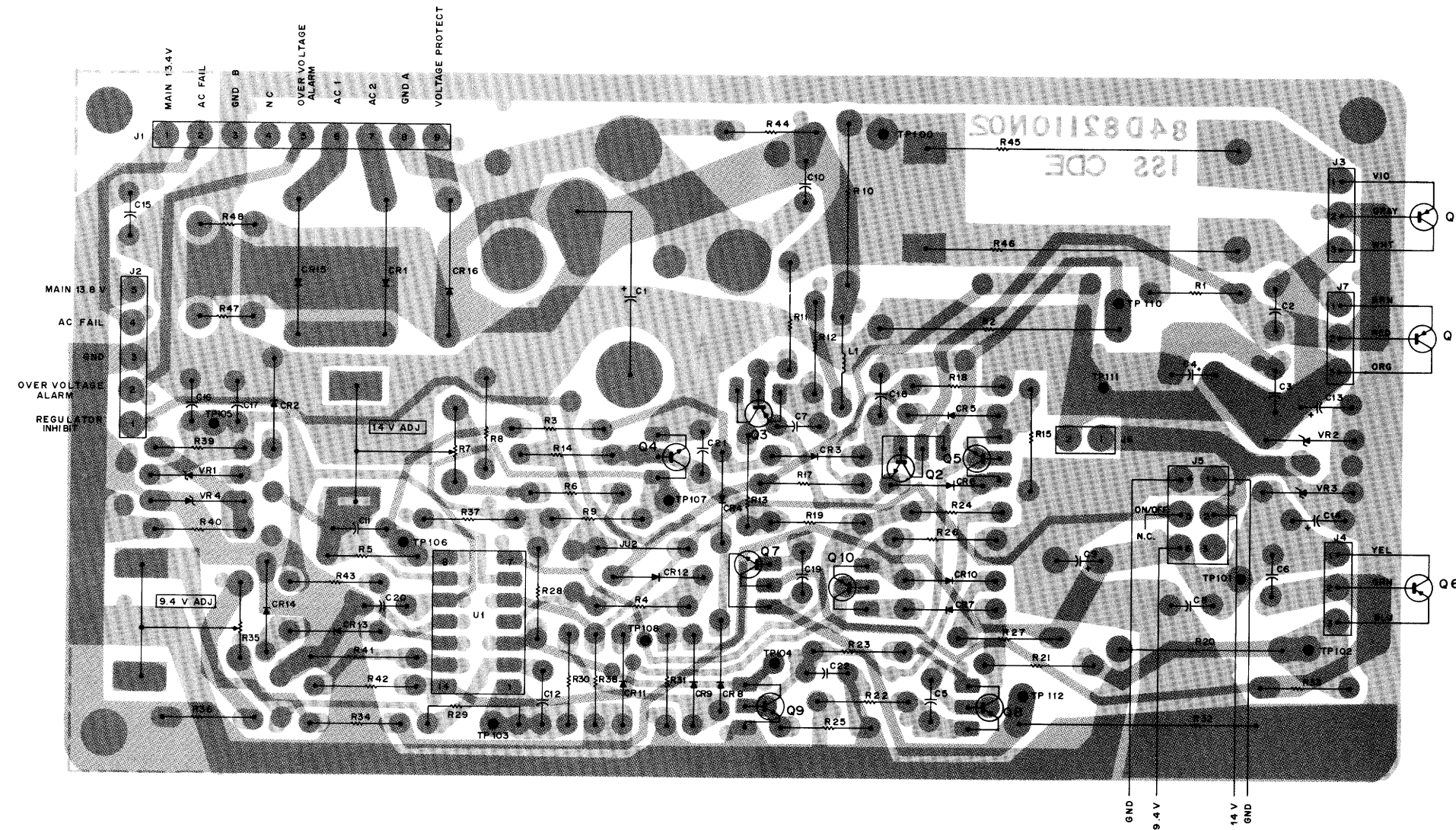

SHOWN FROM COMPONENT SIDE

SOLDER SIDE = BD DEPS-34349-A  
COMPONENT SIDE = BD DEPS-34350-A  
OL DEPS-34351-A

## parts list

TRN5119A Auxiliary Regulator Board PL-7945-A

| REFERENCE SYMBOL | MOTOROLA PART NO. | DESCRIPTION  |
|------------------|-------------------|--|
| C1               | 23-82394A19       | capacitor, fixed: uF: 3600 + 150-10%; 40 V                       |
| C2, 3            | 21-11015B13       | .001 ± 10%; 100 V  |
| C4               | 23-84665F15       | 330 + 10-50%; 25 V   |
| C5 thru 8        | 21-11015B13       | .001 ± 10%; 100 V  |
| C9               | 23-84665F15       | 330 + 10-50%; 25 V   |
| C10              | 21-11015B13       | .001 ± 10%; 100 V  |
| C11, 12          | 21-82428B21       | .01 ± 10-30%; 100 V  |
| C13, 14          | 23-84538G02       | 4.7 ± 20%; 20 V  |
| C15, 16          | 21-11015B13       | .001 ± 10%; 100 V  |
| C17              | 21-11022G39       | 24 pF ± 5%; 50 V   |
| C18, 19          | 21-11015B13       | .001 ± 10%; 100 V  |
| C20              | 21-11022G39       | 24 pF ± 5%; 50 V   |
| C21, 22          | 21-11015B13       | .001 ± 10%; 100 V  |
| CR1              | 48-82525G13       | diode: (see note) silicon  |
| CR2 thru 12      | 48-83654H01       | silicon  |
| CR13, 14         | 48-82392B18       | silicon  |
| CR15             | 48-82525G13       | silicon  |
| CR16             | 48-82525G19       | silicon  |
| J1               | 29-82984N12       | connector, receptacle: male, 8-contact                           |
| J2               | 9-83497F08        | female, 5-contact  |
| J3               | 28-82984N02       | male, 3-contact  |
| J4               | 28-82984N03       | male, 3-contact  |
| J5               | 1-80754D88        | Assembly connector, consists of: Housing, receptacle; 6-position |
| J6               | 15-84953L01       | Contact, receptacle; 6 used                                      |
| J7               | 39-82977N01       | male, 2-contact  |
| J7               | 28-82984N01       | male, 2-contact  |
| J7               | 28-82984N02       | male, 3-contact  |
| JU2              | 6-11009B23        | jumper: "0" ohms   |
| L1               | 24-83961B01       | coil, rf: choke  |
| Q2               | 48-869633         | transistor: (see note) NPN; type M9833                           |
| Q3               | 48-869643         | PNP; type M9643  |
| Q4, 5            | 48-869642         | NPN; type M9642  |
| Q7               | 48-869633         | NPN; type M9833  |
| Q8               | 48-869643         | PNP; typ M9643   |
| Q9, 10           | 48-869642         | NPN; type M9642  |
| R1               | 6-11009A49        | resistor, fixed: ± 5%; 1/4 W: 1k                                 |
| R2               | 17-82177B16       | 100 ± 10%; 5 W   |
| R3               | 6-11009A57        | 2.2k   |
| R4               | 6-11009A03        | 12   |
| R5               | 6-11009A99        | 120k   |
| R6               | 6-11009A59        | 2.7k   |
| R7               | 18-83083G14       | var. 1k  |
| R8               | 6-11009A58        | 2.4k   |
| R9               | 6-11009A69        | 6.8k   |
| R10              | 17-82036G24       | 0.13; 2 W  |
| R11              | 6-84444A01        | 332 ± 1%; 1/8 W  |
| R12              | 6-11009A25        | 100  |
| R13              | 6-11009A73        | 10k  |
| R14              | 6-11009A57        | 2.2k   |
| R15              | 6-10621C81        | 7.87k ± 1%; 1/8 W  |
| R17              | 6-10621C79        | 7.5k ± 1%; 1/8 W   |
| R18              | 6-11009A61        | 3.3k   |
| R19              | 6-11009A73        | 10k  |
| R20              | 17-82036G24       | 0.13; 2 W  |
| R21              | 6-84444A01        | 332 ± 1%; 1/8 W  |
| R22              | 6-11009A25        | 100  |
| R23, 24          | 6-11009A73        | 10k  |
| R25              | 6-11009A57        | 2.2k   |
| R26              | 6-10621C81        | 7.87k ± 1%; 1/8 W  |
| R27              | 6-10621C79        | 7.5k ± 1%; 1/8 W   |
| R28              | 6-11009A69        | 6.8k   |
| R29              | 6-11009A99        | 120k   |
| R30              | 6-11009A57        | 2.2k   |
| R31              | 6-11009A61        | 3.3k   |
| R32              | 17-82177B16       | 100 ± 10%; 5 W   |
| R33              | 6-11009A33        | 220  |
| R34              | 6-11009A53        | 1.5k   |
| R35              | 18-83083G14       | var. 1k  |
| R36              | 6-11009A63        | 3.9k   |
| R37, 38          | 6-11009A89        | 47k  |
| R39              | 6-11009A53        | 1.5k   |
| R40              | 6-11009A39        | 390  |
| R41              | 6-10621C27        | 2.43k ± 1%   |
| R42              | 6-10621D05        | 13.7k ± 1%; 1/8 W  |
| R43, 44          | 6-11009A73        | 10k  |
| R45, 46          | 17-82177B64       | 2.6; 10 W  |
| R47, 48          | 17-82177B12       | 0.7 ± 10%; 5 W   |
| U1               | 51-83629M08       | integrated circuit: (see note) quad op amp                       |

| REFERENCE SYMBOL | MOTOROLA PART NO. | DESCRIPTION                                |
|------------------|-------------------|--|
| VR1              | 48-82256C61       | voltage regulator: (see note) Zener, 5.8 V |
| VR2              | 48-82256C63       | Zener, 17 V                                |
| VR3              | 48-82256C13       | Zener, 14 V                                |
| VR4              | 48-82256C11       | Zener, 10 V                                |

note: For optimum performance, diodes, transistors, and integrated circuits must be ordered by Motorola part numbers.

TRN5119A Auxiliary Regulator Board  
Schematic Diagram, Circuit Board Detail,  
and Parts Lists  
Motorola No. PEPS-34738-C  
(Sheet 1 of 2)  
9/30/85-UP

# OPTION C28AN BATTERY CHARGER POWER SUPPLY MODEL TPN1192A

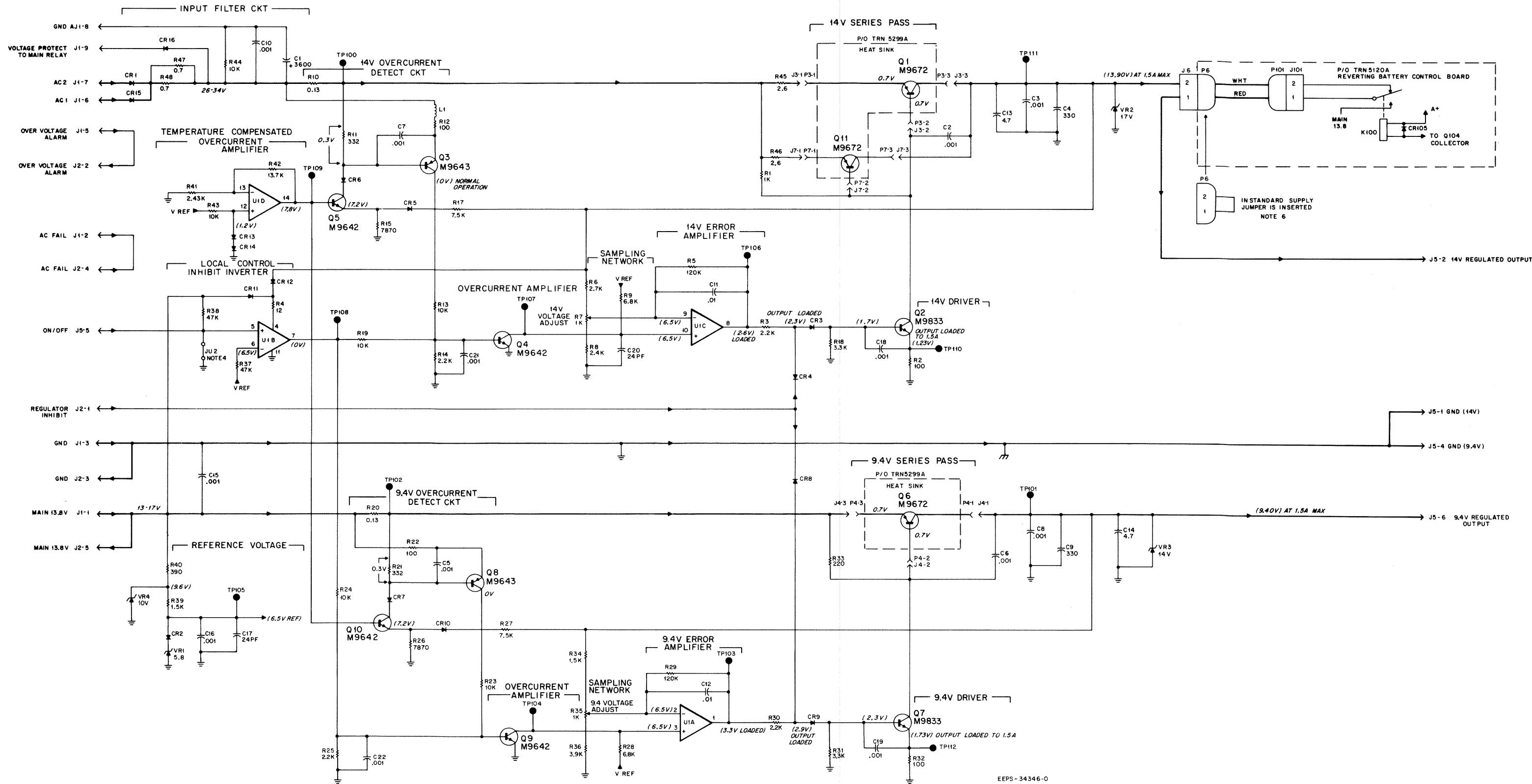

**NOTES:**

1. Unless otherwise indicated: resistor values are in ohms; capacitor values are in microfarads; and inductor values are in millihenries.
  2. Integrated circuits on this board are silicon monolithic.
  3. IC types and connections for this board are as follows:
- | Reference Designation | VCC | Gnd | Mfr's Description |
|-----------------------|-----|-----|-------------------|
| U1                    | 4   | 11  | Op-Amp            |
4. Remove JU2 when on/off switch (in local control models) is used.
  5. DC voltages are nominal. Full rated load. ( ) Other - no load voltages.
  6. For non-battery supply (standard supply) insert connector jumper.

TRN5119A Auxiliary Regulator Board  
Schematic Diagram, Circuit Board Detail,  
and Parts Lists  
Motorola No. PEPS-34738-C  
(Sheet 2 of 2)  
9/30/85-UP

# OPTION C28AN BATTERY CHARGER POWER SUPPLY

MODEL TPN1192A

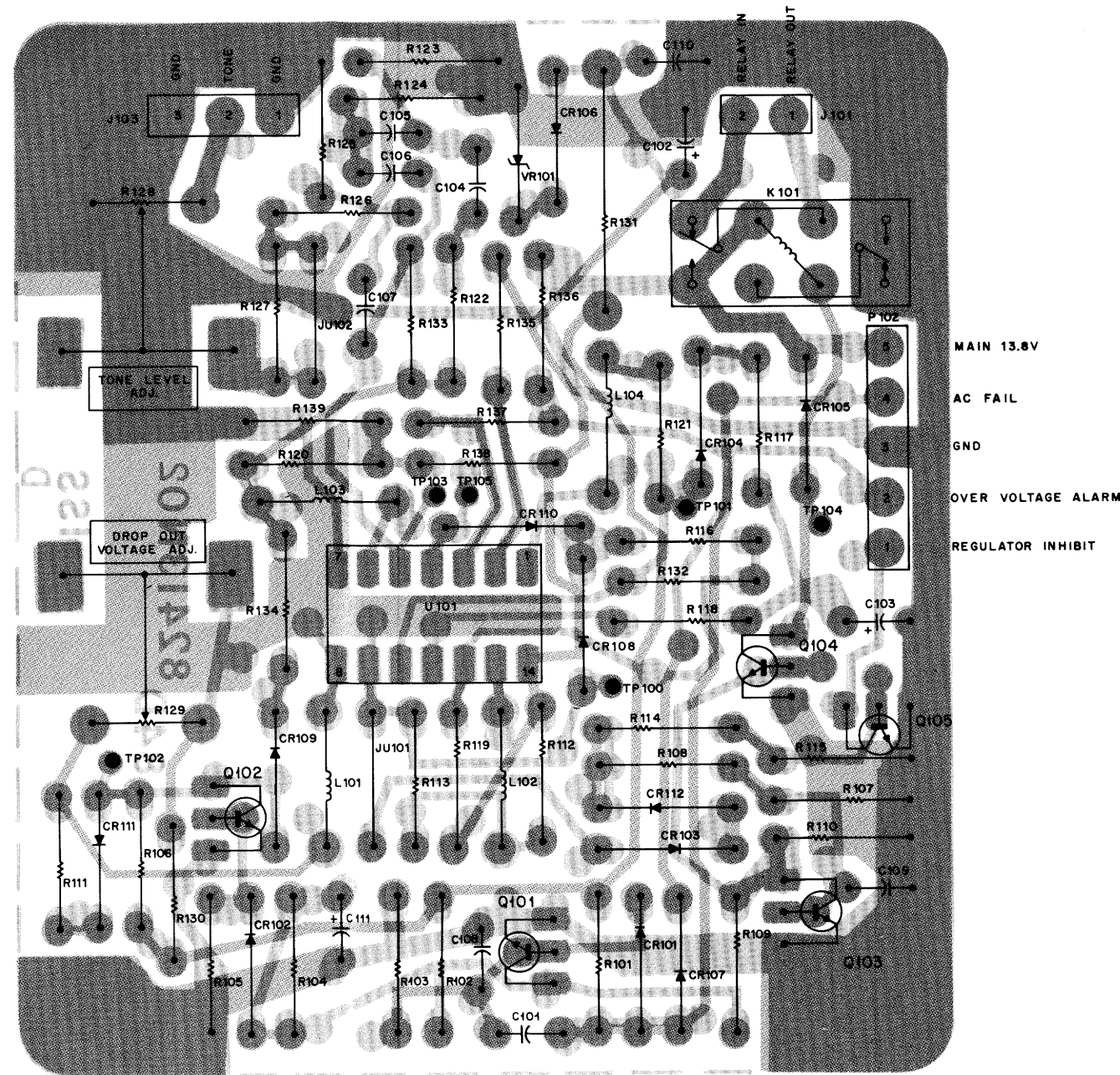

SHOWN FROM COMPONENT SIDE

SOLDER SIDE ● BD CEPS-34352-A  
COMPONENT SIDE ○ BD CEPS-34353-A  
OL CEPS-34354-A

## parts list

TRN5120A Battery Revert Control Board PL-7946-A

| REFERENCE SYMBOL        | MOTOROLA PART NO.                      | DESCRIPTION   |
|-------------------------|--|---|
| C101                    | 21-11015B05                            | capacitor, fixed: uF: unless otherwise stated         |
| C102                    | 23-11019A20                            | 220 pF ± 10%; 100 V                                   |
| C103                    | 23-11013C07                            | 10 ± 20%; 25 V  |
| C104, 105, 106          | 8-11017A05                             | 10 ± 10%; 15 V  |
| C107                    | 8-11017B17                             | .0033 ± 5%; 50 V                                      |
| C108, 109, 110          | 21-11015B05                            | 0.1 ± 10%; 50 V                                       |
| C111                    | 23-11019A27                            | 22 ± 20%; 25 V  |
| CR101 thru 104          | 48-83654H01                            | diode: (see note)                                     |
| CR105, 106              | 48-82466H18                            | silicon   |
| CR107 thru 112          | 48-83654H01                            | silicon   |
| J101                    | 28-82984N01                            | connector, receptacle: male, 2-contact                |
| J103                    | 28-82984N02                            | male, 3-contact                                       |
| JU101, 102              | 6-11009B23                             | jumper: resistive                                     |
| K100                    | 80-84134D01                            | relay: dpdt   |
| L101 thru 104           | 24-83961B02                            | coil, rt: 5-turns; coded GRN                          |
| P102                    | 28-83274N02                            | connector, plug: male: 5-contact; right angle         |
| Q101, 102, 103          | 48-869642                              | transistor: (see note)                                |
| Q104                    | 48-869648                              | NPN; type M9642                                       |
| Q105                    | 48-869642                              | NPN; type M9642                                       |
| R101                    | 6-11009A73                             | resistor, fixed: ± 5%; 1/4 W: unless otherwise stated |
| R102                    | 6-11009A89                             | 10k   |
| R103                    | 6-11009A56                             | 47k   |
| R104                    | 6-11009A81                             | 2k  |
| R105                    | 6-11009A89                             | 22k   |
| R106                    | 6-11009A73                             | 47k   |
| R107                    | 6-11009A89                             | 47k   |
| R108                    | 6-11009A73                             | 47k   |
| R109                    | 6-11009A55                             | 1.8k  |
| R110                    | 6-11009A89                             | 47k   |
| R111                    | 6-11009A97                             | 100k  |
| R112                    | 6-10621E61                             | 562k ± 1%; 1/8 W                                      |
| R113                    | 6-11009B22                             | 1 meg   |
| R114                    | 6-11009A65                             | 4.7k  |
| R115, 116               | 6-11009A89                             | 47k   |
| R117                    | 6-11009A83                             | 27k   |
| R118                    | 6-11009B09                             | 300k  |
| R119, 120, 121          | 6-11009B22                             | 1 meg   |
| R122, 123, 124          | 6-11009A75                             | 12k   |
| R125                    | 6-11009A73                             | 10k   |
| R126                    | 6-11009A49                             | 1k  |
| R127                    | 6-11009B14                             | 470k  |
| R128, 129               | 18-83083G31                            | var. 250k   |
| R130                    | 6-1100B19                              | 750k  |
| R131                    | 6-126C29                               | 150 ± 10%; 1 W  |
| R132                    | 6-11009B22                             | 1 meg   |
| R133                    | 6-11009B14                             | 470 k   |
| R134                    | 6-11009B22                             | 1 meg   |
| R135                    | 6-11009A97                             | 100k  |
| R136                    | 6-11009A73                             | 10k   |
| R137                    | 6-11009A97                             | 100k  |
| R138                    | 6-11009B05                             | 200k  |
| R139                    | 6-11009A97                             | 100k  |
| U100                    | 51-83629M72                            | integrated circuit: (see note) quad op amp            |
| VR101                   | 48-83461E42                            | voltage regulator: (see note) Zener, 6.8 V            |
| <b>mechanical parts</b> |  |   |
| 43-82980N01             | STAND-OFF, board support; 2 used       |   |
| 43-82980N02             | STAND-OFF, board spacer; 2 used        |   |
| 15-83498F38             | HOUSING, connector: 2-position; 2 used |   |
| 29-83499F01             | TERMINAL; 4 used                       |   |

note: For optimum performance, diodes, transistors, and integrated circuits must be ordered by Motorola part numbers.

# OPTION C28AN BATTERY CHARGER POWER SUPPLY

MODEL TPN1192A

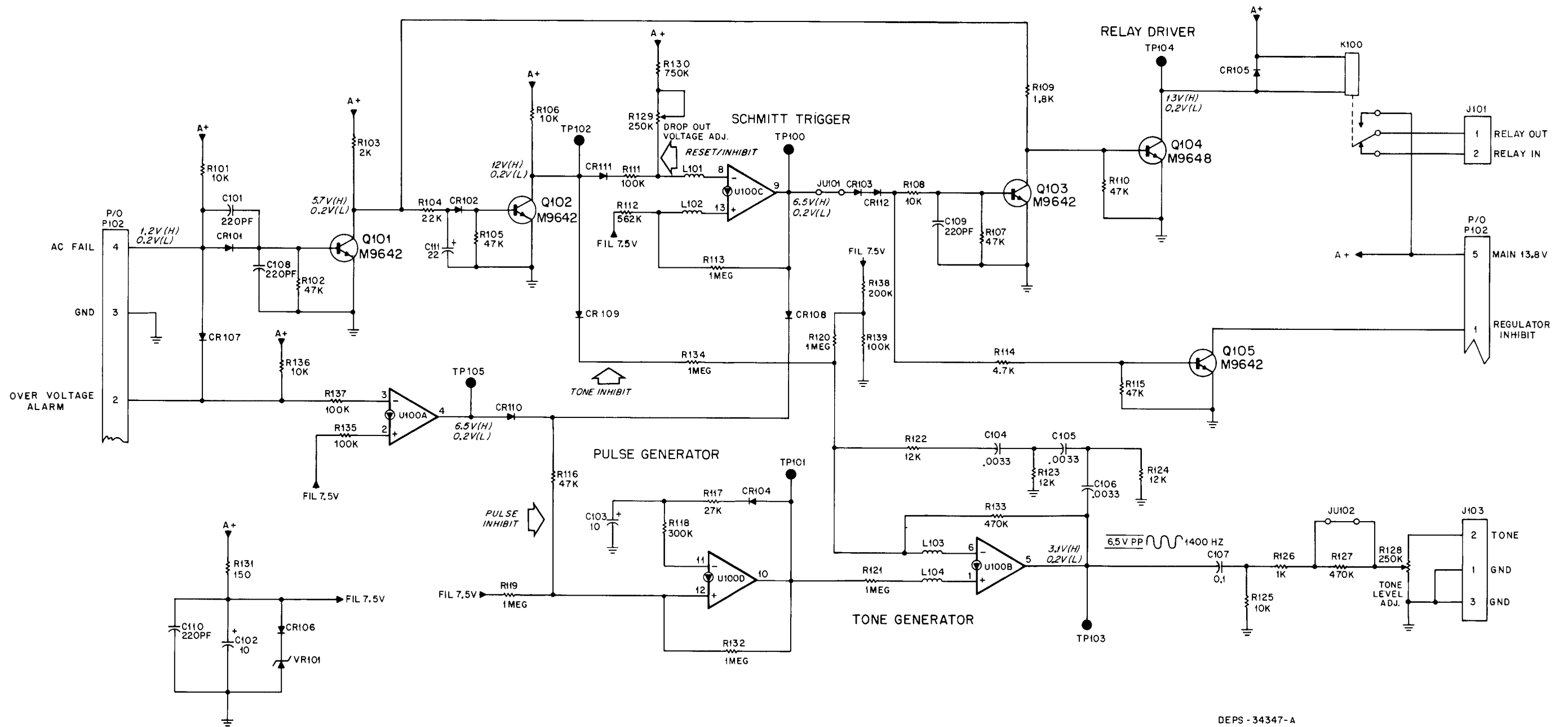

DEPS - 34347 - A

TRN5120A Battery Revert Control Board  
Schematic Diagram, Circuit Board Detail,  
and Parts Lists  
Motorola No. PEPS-34742-A  
(Sheet 2 of 2)  
10/31/83 - UP

BATTERY CHARGER POWER SUPPLY

# OPTION C28AN BATTERY CHARGER POWER SUPPLY

MODEL TPN1192A

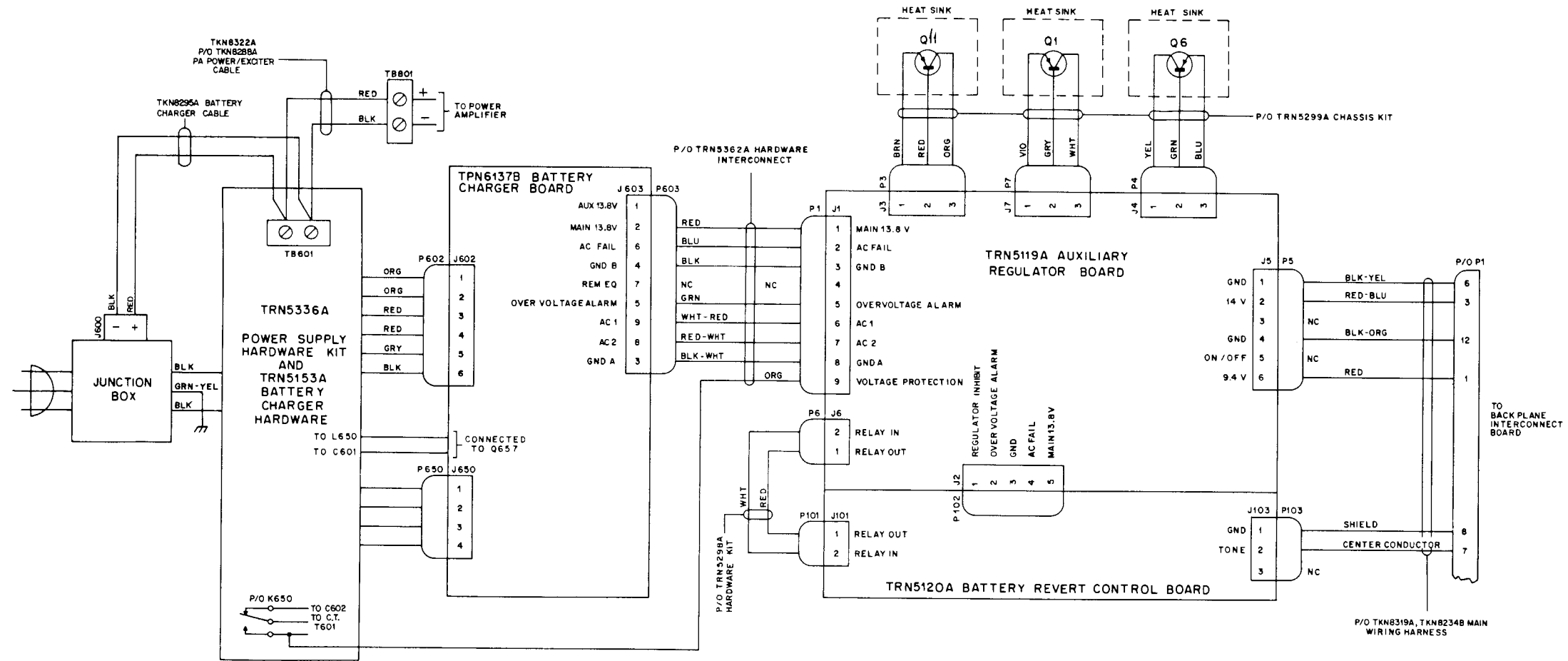

DEPS-34366-A





**MOTOROLA INC.**  
Communications  
Sector

**DUPLEXER**  
MODELS TLD2502A, TLD2622A  
148-174 MHz

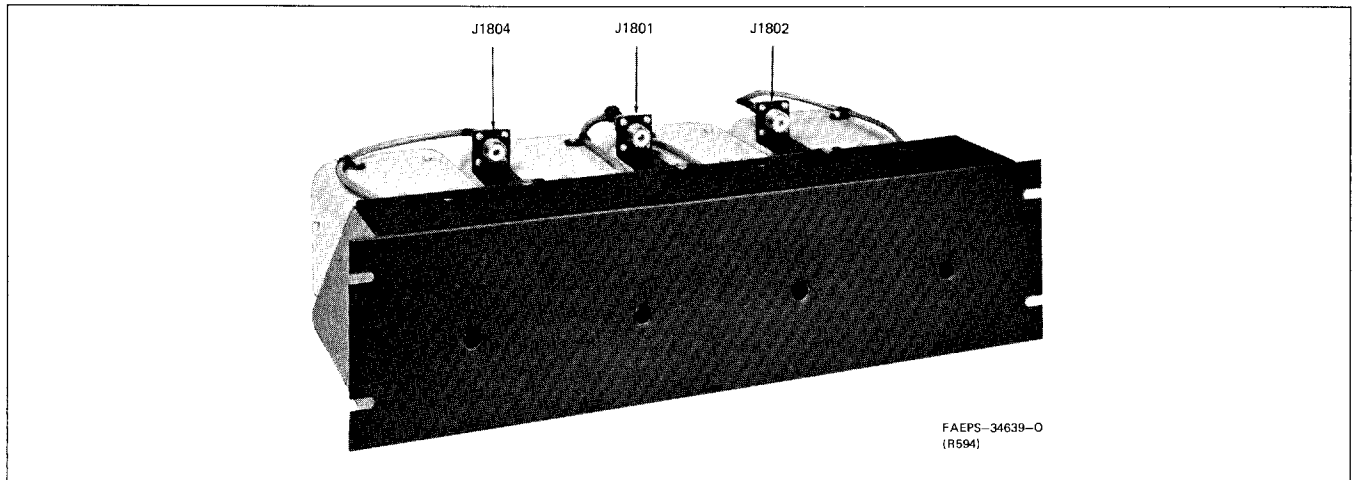

Figure 1. Typical 4-Cavity Duplexer

## 1. INTRODUCTION

This duplexer is for use with Motorola FM two-way radio communications equipment operating in the 148-174 MHz frequency range. Figure 1 is a typical 4-cavity duplexer. It utilizes cavity resonators with a special internal loading construction to achieve a size much less than one-quarter wavelength. The resonators are tuned with an adjustable center conductor. The resonators use a unique temperature compensating mechanism and uniquely adjustable coupling loops. Specially designed low-profile cable connectors are used to obtain an extremely compact package.

These units may be used in the antenna circuit of a base station or repeater to eliminate or minimize receiver desensitization or intermodulation from strong signals. Similarly, they may be used to reduce transmitter noise or intermodulation products.

## 2. FIELD INSTALLATION

Step 1. Carefully unpack the unit and check for concealed damage.

Step 2. The units are designed to mount on any standard 19-inch wide rack. Select position in rack for best location of unit, i.e., closest proximity to associated equipment inputs and outputs.

Step 3. Mount the unit in place in rack with appropriate mounting hardware. The hardware supplied is intended for use with Motorola cabinetry and equipment racks.

Step 4. Connect the duplexer to the transmitter and receiver. See Refer to Figure 2 (for 2-cavity hook-up), and Figure 12 (for 4-cavity, hook-up).

**technical writing services**

Table 1.  
Model TLD2502A Performance Specifications

|  |                       |
|--|-----------------------|
| Model Number                           | TLD2502A              |
| Insertion Loss                         | 1.7 dB                |
| Isolation at Transmit Frequency        | 82 dB                 |
| Isolation at Receiver Frequency        | 82 dB                 |
| Minimum Transmitter Receiver Isolation | 52 dB                 |
| Minimum Frequency Separation           | 1.5 MHz               |
| VSWR Maximum                           | 1.5:1                 |
| Maximum Power Input                    | 125 W                 |
| Temperature Range                      | -30°C to +60°C        |
| Size                                   | 19" x 5-1/2" x 8-1/2" |
| Termination                            | UHF Female            |

SPECIFICATIONS SUBJECT TO CHANGE WITHOUT NOTICE

Model Complement

| TLD2502A Duplexer |                              |
|-------------------|------------------------------|
| TKN6471A          | Cable (2 used)               |
| TKN8292A          | Cable, Antenna               |
| TKN8293A          | Cables, Receiver/Transmitter |
| TLD8392A          | Cavity Filter (4 used)       |
| TRN5445A          | Hardware                     |

Table 2.  
Model TLD2622A Performance Specifications

|  |                       |
|--|-----------------------|
| Model Number                           | TLD2622A              |
| Insertion Loss                         | 1.0 dB                |
| Isolation at Transmit Frequency        | 52 dB                 |
| Isolation at Receiver Frequency        | 52 dB                 |
| Minimum Transmitter Receiver Isolation | 35 dB                 |
| Minimum Frequency Separation           | 3.5 MHz               |
| VSWR Maximum                           | 1.5:1                 |
| Maximum Power Input                    | 125 W                 |
| Temperature Range                      | -30°C to +60°C        |
| Size                                   | 19" x 5-1/2" x 8-1/2" |
| Termination                            | UHF Female            |

SPECIFICATIONS SUBJECT TO CHANGE WITHOUT NOTICE

Model Complement

| TLD2622A Duplexer |                              |
|-------------------|------------------------------|
| TKN8404A          | Cable, Antenna               |
| TKN8934A          | Cables, Receiver/Transmitter |
| TLD8392A          | Cavity Filter (2 used)       |
| TRN9417A          | Hardware                     |

Step 5. The duplexer must be connected to the transmitter and receiver with appropriate lengths of 50-ohm coaxial cable (customer supplied) to fit the individual installation.

**IMPORTANT**

All duplexers are factory set and SHOULD NOT be "fine-tuned" into the antenna systems, since isolation changes significantly with any readjustment of the center tuning shaft. Station and duplexer performance will remain within specification without duplexer readjustment, if the antenna VSWR is LTE 1:51. Antenna VSWR can be measured by inserting a VHF-rated, in-line wattmeter (capable of withstanding at least 120 watts) between the duplexer and the antenna, via J1810. The ratio of the forward to reverse power should be GTE 25. If the antenna VSWR exceeds 1.51, the antenna system must be corrected. If the duplexers must be retuned, due to station frequency re-assignment, follow Recommended Tuning Procedure, paragraph 5.

**3. THEORY OF OPERATION**

Each resonant cavity, technically a reentrant quarter-wave resonator, is a very high Q (low loss) tunable tank circuit. A special internal construction uses two different characteristic impedances for the center conductor to achieve an overall length considerably less than a quarter-wavelength. The dimensions are designed for minimum loss. The cavities are tuned to the required pass frequency by an adjustment which changes the length of the center conductor. Lower frequencies have more of the center conductor inside the cavity, higher frequencies have correspondingly less. Special bimetal washers are used for temperature compensation to minimize detuning due to ambient temperature changes.

Each resonant cavity is fitted with a specially designed pair of coupling elements (loops). These loops efficiently convert energy from the 50-ohm coaxial cable to the correct mode inside the resonant structure. When the cavity is not tuned to resonance, most of the energy is reflected. Only a small portion is able to excite the correct mode and reach the output element.

The input and output coupling loops are placed very close to each other, to take advantage of mutual coupling. A small amount of energy is always being transferred between coupling loops because of their proximity. At one frequency, the energy transferred by mutual coupling cancels the energy transferred across by the resonant mode within the cavity. Thus, at one frequency, there is a reject notch in addition to the normal selectivity of the cavity. The proximity of the loops provides inductive coupling. In addition, a precision high Q trimmer capacitor is connected across the loops. This capacitor can adjust the net coupling to be inductive, the notch occurs above the pass frequency. When the net

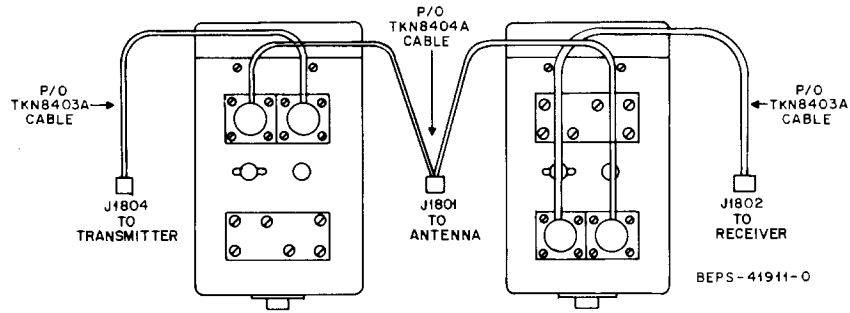

Figure 2. 2-Cavity Duplexer Cabling Detail

coupling is capacitive, the notch occurs below the pass frequency.

Cavities are used on each side of the duplexer. The cavities tuned to pass the lower frequency have the coupling loops tuned to notch out higher frequency, while the cavities tuned to pass the higher frequency have the coupling loops tuned to notch out the lower frequency. Quarter-wave coupling is used between cavities to obtain minimum passband bandwidth and minimum insertion loss.

#### 4. REMOVAL/REPLACEMENT OF COUPLING LOOPS

Coupling loops are factory-installed. If it becomes necessary to change coupling loops, refer to Figures 3, 9 and 10 and use the following procedure.

##### 4.1 REMOVAL PROCEDURE

The cable shields are soldered to the connector portion of the loops. These shields must first be unsoldered before the loops can be removed. The shields cannot be attached to the cavity body because the cavity body acts as a heat sink.

Step 1. Remove the eight screws securing the connectors to the cavity body.

Step 2. The two coupling loops are internally connected and must be removed together. Using a 150-watt soldering iron, first unsolder and remove the connector covers from the two connectors.

Step 3. Grasp the center connector of the cable (at the point where it enters the center pin of the connector) with long nose pliers. Melt the solder around the cable shield and pull the cable off the connector. Do the same for the other connector.

Step 4. Remove the two knurled adjusting knobs taking care not to lose the washers. Now the loops are completely free and can be removed from the can.

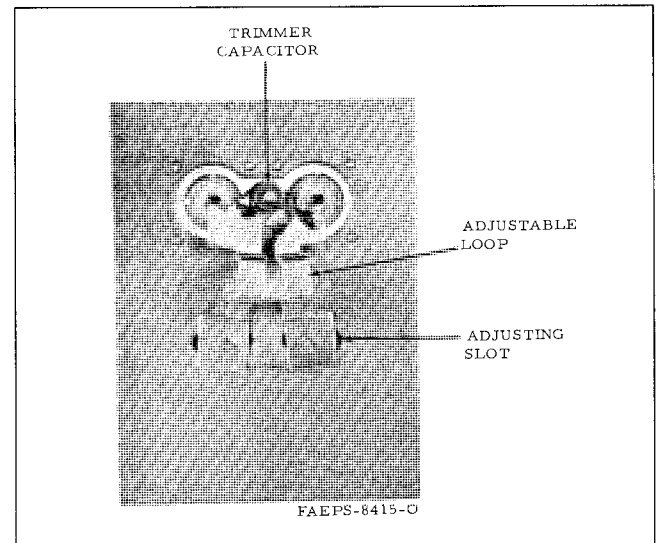

Figure 3. Coupling Loop (Interior View)

Step 5. Maneuver both loops to the left so that the trimmer capacitor can fit through the left side of the hole and then remove the two loops together.

##### 4.2 REPLACEMENT PROCEDURE

Step 1. Insert the loop assembly into the mounting holes and maneuver both loops to the left so that the trimmer capacitor will fit through the left side of the hole.

Step 2. Position the loops so that the tapped holes in the end of the loops are visible through the adjusting slots.

Step 3. Insert the knurled adjusting screw, along with the nylon and lock washers, into the tapped hole.

Step 4. Attach the connectors to the can using the eight self-tapping screws making certain that the connector cable slot is facing in the proper direction to insert the cable.

Step 5. Insert the cable into the connector cable slot while pressing the center conductor into the center pin of the connector.

Step 6. Place the connector cover over the connector and solder the cable shield and connector cover to the connector.

## 5. RECOMMENDED TUNING PROCEDURE

All duplexers are tuned to the customer-specified frequencies prior to shipment from the factory. If system performance indicates that the duplexer is detuned, one of the following procedures may be used. Do not attempt to retune unless the following procedures have been read and it is certain that performance does not meet specifications.

The following tuning procedures assume that the entire duplexer is to be retuned. If it is desired to perform a minor "touch-up", refer to paragraph 5.3 of this tuning procedure. When left and right are used in the following procedures, this shall mean facing the tuning shaft end and with the connectors facing up.

### 5.1 METHOD 1

#### 5.1.1 Recommended Test Equipment

- Motorola R-2001 or R-1201 Signal Generator.
- Tunable receiver or two Motorola receivers, one tuned to each of the frequencies to be duplexed.

#### 5.1.2 Tuning Procedure

Step 1. Move sliding screws as far apart as possible on each cavity and then tighten the screws.

Step 2. Turn trimmer capacitors fully counter-clockwise. **CHANGED PER SMR-5812**

Step 3. Tune the signal generator and the receiver to the duplex receive frequency.

Step 4. Connect the signal generator to the antenna port and the receiver to the right-hand port.

Step 5. Tune the right-hand cavity(s) for minimum insertion loss by adjusting the tuning rod screw.

Step 6. Tune the signal generator and the receiver to the duplex transmit frequency.

Step 7. Connect the receiver to the left-hand port.

Step 8. Tune the left-hand cavity(s) for minimum insertion loss by adjusting the tuning rod screw.

Step 9. Connect the receiver to the right-hand port.

Step 10. Tune the right-hand cavity(s) for maximum attenuation by using procedure 5.4, "Tuning the Notch".

Step 11. Tune the signal generator and the receiver to the duplex receive frequency.

Step 12. Connect the receiver to the left-hand port.

Step 13. Tune the left-hand cavity(s) for maximum attenuation by using procedure 5.4.

Step 14. Repeat Steps 3 through 13, but only tune the trimmer capacitors when tuning the notches.

## 5.2 METHOD 2

### 5.2.1 Recommended Test Equipment

- Mixer circuit constructed as shown in Figure 4.

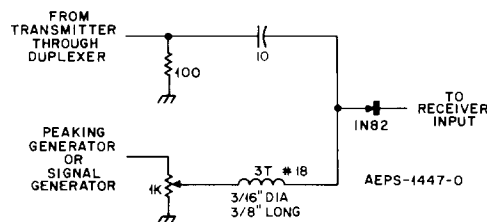

Figure 4. Mixer Circuit

- Motorola R-2001 or R1040 Signal Generator.
- I-F output from R1201 Series Signal Generator equal to the duplex frequency separation or a Motorola R1033A Portable Test Set with a crystal frequency equal to the duplex frequency separation.
- Motorola S1350A Wattmeter.
- Motorola T1013A RF Load Resistor.
- Isolated Tee connector (construct this by removing the Tee port center pin of a UHF Tee connector). This provides 30 to 40 dB of isolation between the shunt

path and the direct path through the Tee to protect the receiver when the transmitter is keyed.

- Transmitter and receiver from the station to be duplexed.

**5.2.2 Operation of the Mixer Circuit**

Alignment of the duplexers can be simplified by using the mixer circuit shown in Figure 4. The mixer receives inputs from the transmitter and a low frequency source. The outputs from the mixer are frequencies above and below the transmitter frequency at separations equal to the output of the low frequency generator.

The receiver will respond to one of the mixer products and thus can be used indirectly to detect the transmitter frequency.

**5.2.3 Tuning Procedure**

Step 1. Move sliding screws as far apart as possible on each cavity and then tighten the screws.

Step 2. Turn trimmer capacitors fully counterclockwise.

Step 3. Connect the equipment as shown in Figure 5.

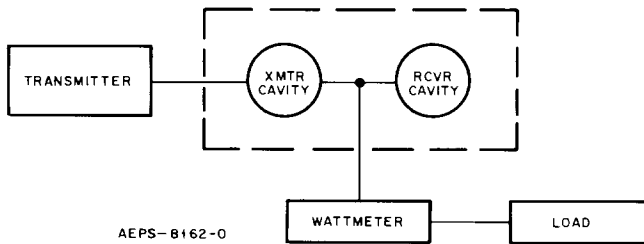

Figure 5.  
Method 2 Transmitter Branch Pass Test Setup

Step 4. Tune the left-hand cavity(s) for a maximum power reading on the wattmeter by adjusting the tuning rod screw.

Step 5. Connect the equipment as shown in Figure 6.

Step 6. Tune the signal generator to the receive frequency.

Step 7. Tune the right-hand cavity(s) for a minimum insertion loss (maximum signal at the receiver) by adjusting the tuning rod screw.

Step 8. Connect the equipment as shown in Figure 7.

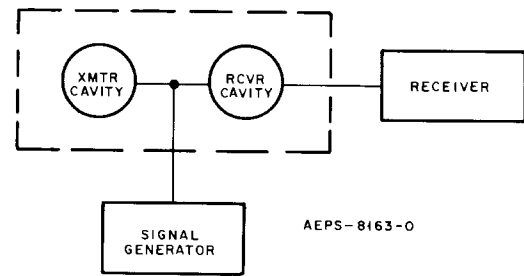

Figure 6.  
Method 2 Receiver Branch Pass Test Setup

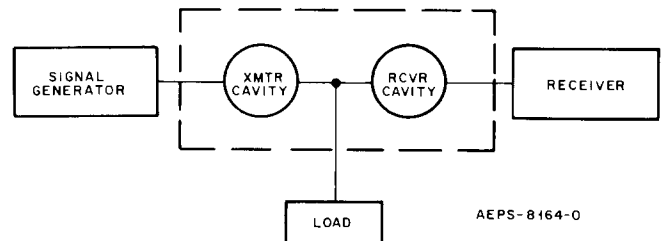

Figure 7.  
Method 2 Transmitter Branch Reject Test Setup

Step 9. Tune the left-hand cavity(s) for maximum attenuation by using procedure 5.4, "Tuning the Notch".

Step 10. Connect the equipment as shown in Figure 8.

Step 11. Set the local oscillator source to the exact duplex frequency separation.

Step 12. Tune the right-hand cavity(s) for maximum attenuation by using procedure 5.4.

Step 13. Repeat Steps 3 through 12 but only tune the trimmer capacitors when tuning the notches.

Step 14. Connect the duplexer to the transmitter, receiver and antenna with 50-ohm coaxial cable. Adjust the transmitter final amplifier for rated power into the duplexer.

**5.3 MINOR "TOUCH-UP" PROCEDURES**

**5.3.1 Method A**

Step 1. Using the Recommended Test Equipment given in paragraph 5.1.1, tune the signal generator and the receiver to the duplex receive frequency.

Step 2. Connect the signal generator to the antenna port and the receiver to the right-hand port.

Step 3. Tune the right-hand cavity(s) for minimum insertion loss by adjusting the tuning rod screw.

Step 4. Tune the signal generator and the receiver to the duplex transmit frequency.

Step 5. Connect the receiver to the left-hand port.

Step 6. Tune the left-hand cavity(s) for minimum insertion loss by adjusting the tuning rod screw.

Step 7. Connect the receiver to the right-hand port.

Step 8. Tune the trimmer capacitor(s) on the righthand cavity(s) for maximum attenuation.

Step 9. Tune the signal generator and the receiver to the duplex receive frequency.

Step 10. Connect the receiver to the left-hand port.

Step 11. Tune the trimmer capacitor(s) on the left-hand cavity(s) for maximum attenuation.

### 5.3.2 Method B

Step 1. Using the Recommended Test Equipment given in paragraph 5.2.1, connect the equipment as shown in Figure 5.

Step 2. Tune the left-hand cavity(s) for a maximum power reading on the wattmeter by adjusting the tuning rod screw.

Step 3. Connect the equipment as shown in Figure 6.

Step 4. Tune the signal generator to the receive frequency.

Step 5. Tune the right-hand cavity(s) for a minimum insertion loss (maximum signal at the receiver) by adjusting the tuning rod screw.

Step 6. Connect the equipment as shown in Figure 7.

Step 7. Tune the trimmer capacitor(s) on the left-hand cavity(s) for maximum attenuation.

Step 8. Connect the equipment as shown in Figure 8.

Step 9. Set the local oscillator source to the exact duplex frequency separation.

Step 10. Tune the trimmer capacitor(s) on the righthand cavity(s) for maximum attenuation.

## 5.4 TUNING THE NOTCH

### 5.4.1 If the Notch (Reject) Frequency is Below the Pass Frequency:

Step 1. Move the sliding screws as far apart as possible and then tighten the screws.

Step 2. Tune the trimmer capacitor for maximum attenuation at the notch frequency.

### 5.4.2 If the Notch (Reject) Frequency is Above the Pass Frequency:

Step 1. Turn the trimmer capacitor completely counterclockwise and then clockwise two full turns.

Step 2. Adjust the sliding screws for maximum attenuation at the notch frequency and then tighten the screws.

Step 3. Tune the trimmer capacitor for maximum attenuation at the notch frequency.

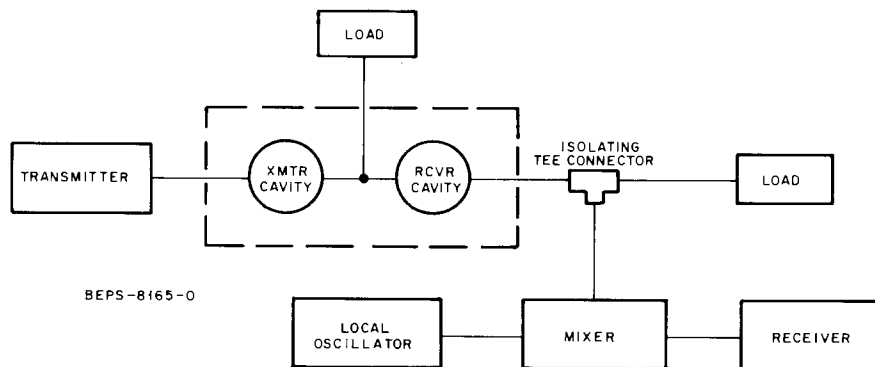

Figure 8.  
Method 2 Receiver Branch Reject Test Setup

**NOTE**

The overall dimensions and the stripping of cables are critical, and it is therefore recommended that an entire cable kit be ordered using the correct TKN number (TKN6471A, TKN8292A, TKN8293A, TKN8403A, or TKN8404A). The connector covers (Code No. 6) are included in the cable kits TKN8292A and TKN8293A or Hardware Kit TRN9417A.

**parts list**

TLD8392A Cavity Filter PL-1677-A

| REFERENCE SYMBOL | MOTOROLA PART NO. | DESCRIPTION   |
|------------------|-------------------|---|
| 1                | 3-3375            | SCREW, tapping: 6-20 x 5/16" plain hex head (4 req'd)           |
| 2                | 1-84312D01        | CAVITY ASSEMBLY   |
| 3                | 1-80723B90        | LOOP ASSEMBLY, coupling   |
| 4                | 47-84313D01       | TUNING SHAFT  |
| 5                | 3-400356          | SCREW, tapping: 4-32 x 1/4" Phillips hex head (8 req'd)         |
| 5                | 4-9777            | LOCKWASHER, #4 split (8 used)                                   |
| 7                | 3-82245E04        | SCREW, knurled head (2 req'd)                                   |
| 7                | 4-9746            | LOCKWASHER, No. 8 med. split (2 req'd)                          |
| 7                | 4-82418B01        | WASHER, nylon (2 req'd)   |
| 9                | 15-84993C01       | COVER, housing  |
| 10               | 4-84994C01        | WASHER, temperature compensating ("LE" stamped on concave side) |
| 11               | 4-84994C02        | WASHER, temperature compensating ("LE" stamped on convex side)  |
| 12               | 1-84985C01        | LOCKING NUT ASSEMBLY  |
| 13               | 3-7110            | SCREW, set: 8-32 x 3/16" allen head                             |
| 14               | 1-84314D01        | TUNING CAN ASSEMBLY   |
| 15               | 42-824977         | RING, truarc  |
| —                | 33-84332B01       | LABEL, nameplate  |

TKN8403A Station Duplexer Cable PL-9732-O

| REFERENCE SYMBOL           | MOTOROLA PART NO. | DESCRIPTION                                   |
|----------------------------|-------------------|---|
| J1802,1804                 | 9-82442E05        | connector, receptacle: female; single contact |
| <b>mechanical parts</b>    |                   |   |
| 18                         | 2-131435          | NUT, 4-40 x 1/4 x 3/32"; 4 used               |
| 18                         | 3-1937            | SCREW, machine: 4-40 x 5/16"; 4 used          |
| 18                         | 4-114583          | LOCKWASHER, #4 split; 4 used                  |
| 19                         | 7-83454N01        | BRACKET, connector; 1 used                    |
| 20                         | 15-483599         | HOOD, receptacle; 1 used                      |
| <b>non-referenced item</b> |                   |   |
| —                          | 30-83278B01       | CABLE, coaxial                                |

TRN9417A Duplexer Hardware Mounting PL-9733-O

| REFERENCE SYMBOL | MOTOROLA PART NO. | DESCRIPTION                                  |
|------------------|-------------------|--|
| 6                | 15-84002D01       | COVER, connector; 4 used                     |
| 8                | 3-3398            | SCREW, tapping: 6-20 x 5/16"; 11 used        |
| —                | 3-83498N08        | SCREW, tapping: black; M6 x 7.0 x 10; 4 used |
| 16               | 27-82934N01       | CHASSIS                                      |
| —                | 66-82846D01       | TOOL, tuning                                 |

TKN8404A Antenna Duplexer Cable PL-9734-O

| REFERENCE SYMBOL           | MOTOROLA PART NO. | DESCRIPTION                                   |
|----------------------------|-------------------|---|
| J1801                      | 9-82442E05        | connector, receptacle: female; single contact |
| <b>mechanical parts</b>    |                   |   |
| 18                         | 2-131435          | NUT, 4-40 x 1/4 x 3/32"; 4 used               |
| 18                         | 3-1937            | SCREW, machine: 4-40 x 5/16"; 4 used          |
| 18                         | 4-114583          | LOCKWASHER, #4 split; 4 used                  |
| 19                         | 7-83454N01        | BRACKET, connector                            |
| 21                         | 15-82582H01       | HOOD, receptacle                              |
| <b>non-referenced item</b> |                   |   |
| —                          | 30-83278B01       | CABLE, coaxial                                |

TKN8293A Cable Duplexer-Station PL-8047-O

| REFERENCE SYMBOL        | MOTOROLA PART NO. | DESCRIPTION                                   |
|-------------------------|-------------------|---|
| J1802,1804              | 9-82442E05        | connector, receptacle: female; single contact |
| <b>mechanical parts</b> |                   |   |
| 6                       | 15-84002D01       | COVER, connector; 2 used                      |
| 18                      | 2-131435          | NUT, 4-40 x 1/4 x 3/32"; 8 used               |
| 18                      | 3-1937            | SCREW, machine: 4-40 x 5/16"; 8 used          |
| 18                      | 4-114583          | LOCKWASHER, #4 split; 8 used                  |
| 19                      | 7-83454N01        | BRACKET, connector; 2 used                    |
| 20                      | 15-483599         | HOOD, receptacle; 2 used                      |

TKN6471A Cable Duplexer PL-8048-O

| REFERENCE SYMBOL        | MOTOROLA PART NO. | DESCRIPTION                                  |
|-------------------------|-------------------|--|
| 6                       | 15-84002D01       | COVER, connector; 2 used                     |
| <b>mechanical parts</b> |                   |  |
| 8                       | 3-3398            | SCREW, tapping: 6-20 x 5/16"; 19 used        |
| —                       | 3-83498N08        | SCREW, tapping: black; M6 x 7.0 x 10; 4 used |
| 16                      | 27-82934N01       | CHASSIS                                      |
| 17                      | 42-82143C05       | CLAMP, cable 3/16"; 4 used                   |
| —                       | 66-82846D01       | TOOL, tuning                                 |

TRN5445A Hardware Mounting Duplexer PL-8049-O

| REFERENCE SYMBOL | MOTOROLA PART NO. | DESCRIPTION                                  |
|------------------|-------------------|--|
| 8                | 3-3398            | SCREW, tapping: 6-20 x 5/16"; 19 used        |
| —                | 3-83498N08        | SCREW, tapping: black; M6 x 7.0 x 10; 4 used |
| 16               | 27-82934N01       | CHASSIS                                      |
| 17               | 42-82143C05       | CLAMP, cable 3/16"; 4 used                   |
| —                | 66-82846D01       | TOOL, tuning                                 |

TKN8292A Cable Duplexer-Antenna PL-8050-O

| REFERENCE SYMBOL        | MOTOROLA PART NO. | DESCRIPTION                                   |
|-------------------------|-------------------|---|
| J1801                   | 9-82442E05        | connector, receptacle: female; single contact |
| <b>mechanical parts</b> |                   |   |
| 6                       | 15-84002D01       | COVER, connector; 2 used                      |
| 18                      | 2-131435          | NUT, 4-40 x 1/4 x 3/32"; 4 used               |
| 18                      | 3-1937            | SCREW, machine: 4-40 x 5/16"; 4 used          |
| 18                      | 4-114583          | LOCKWASHER, #4 split; 4 used                  |
| 19                      | 7-83454N01        | BRACKET, connector                            |
| 21                      | 15-82582H01       | HOOD, receptacle                              |

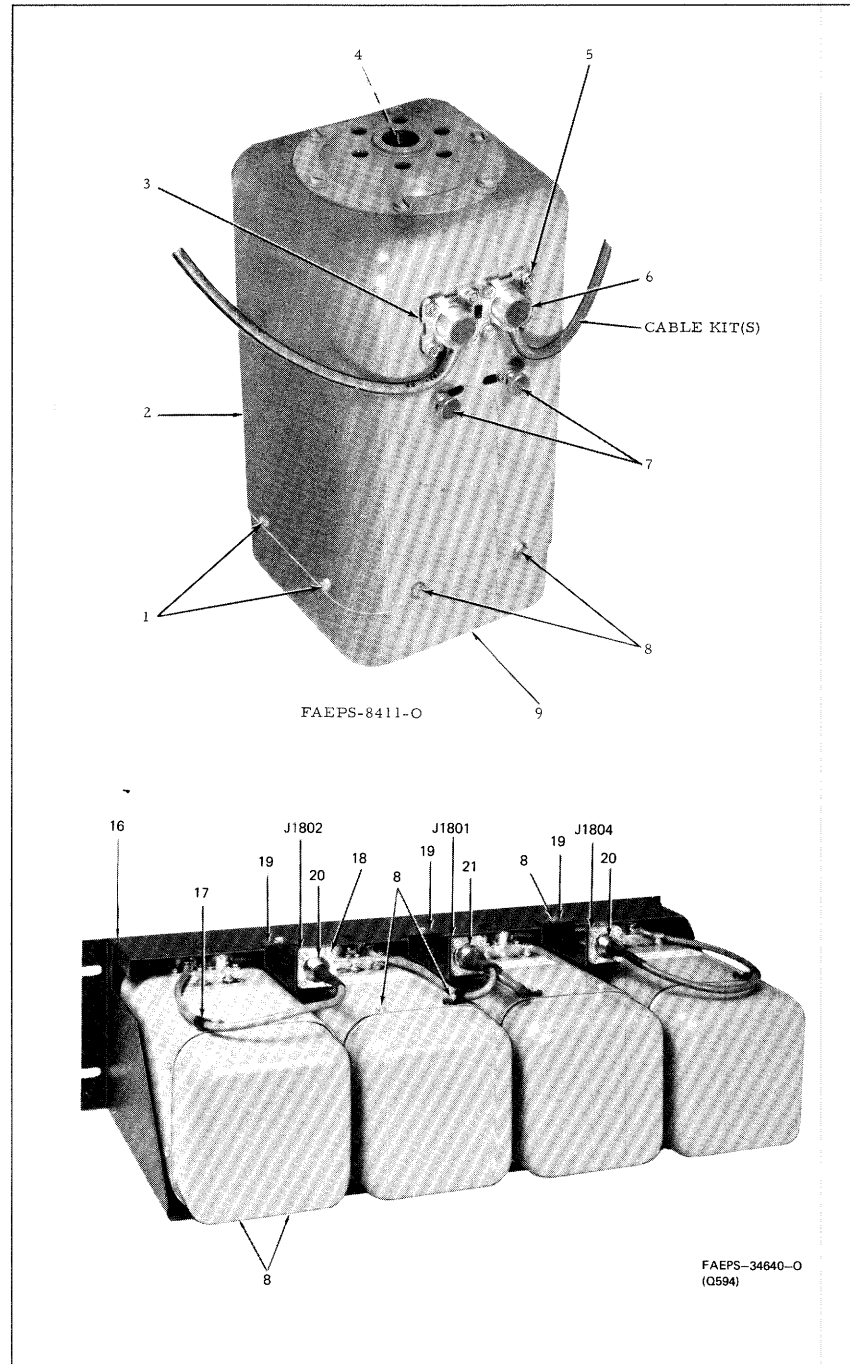

Figure 9. Cavity Filter Parts Location Detail

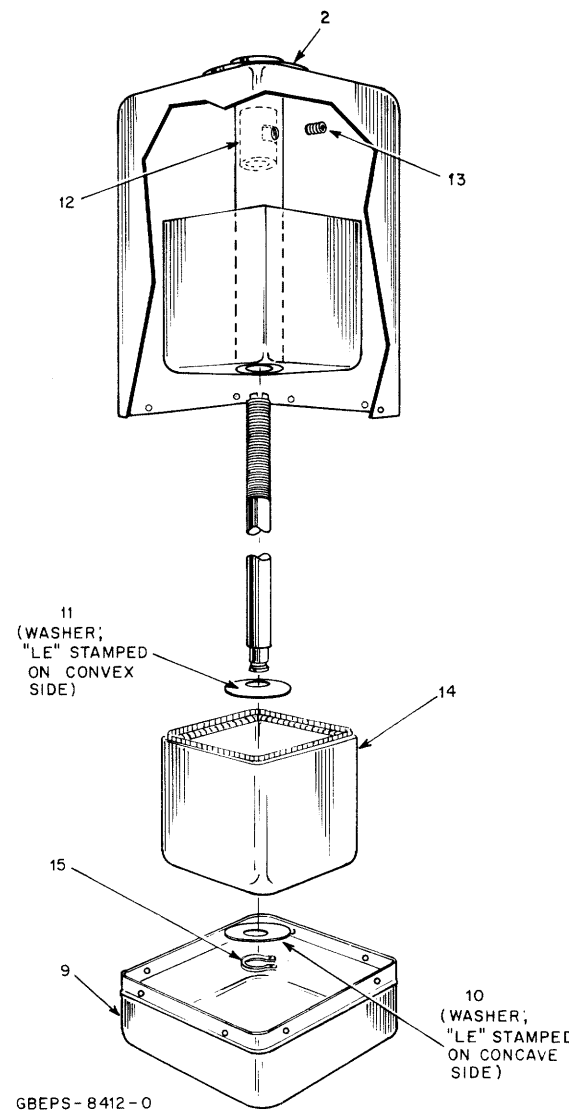
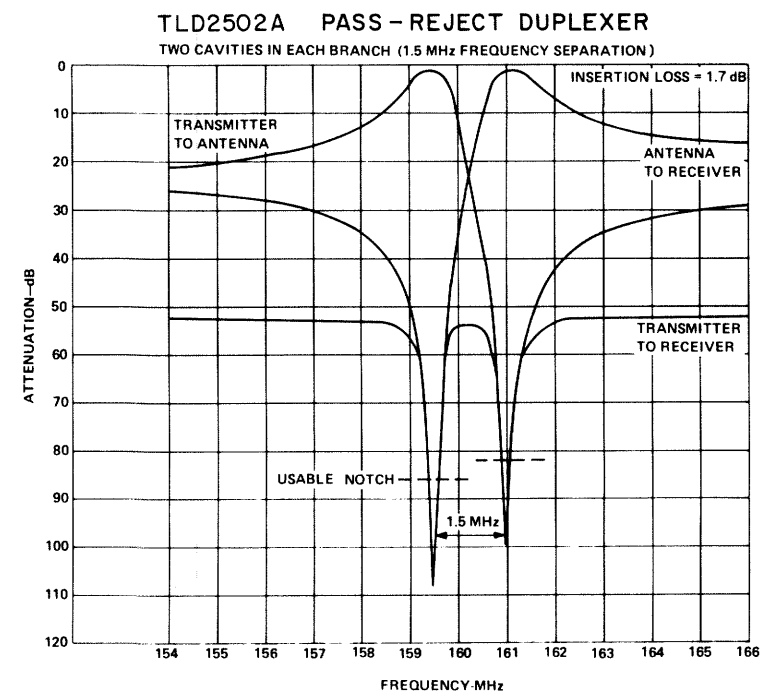
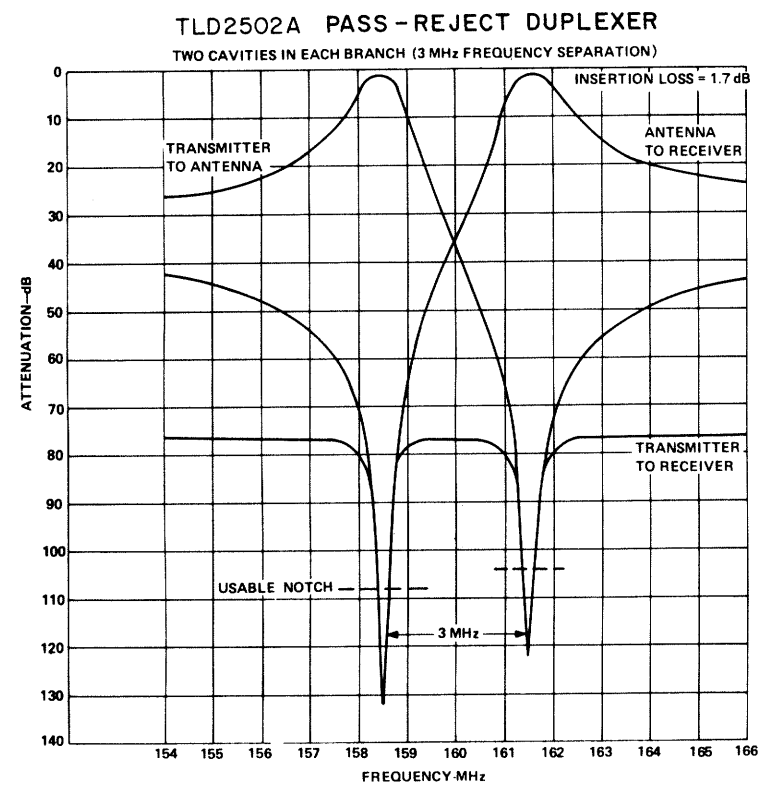
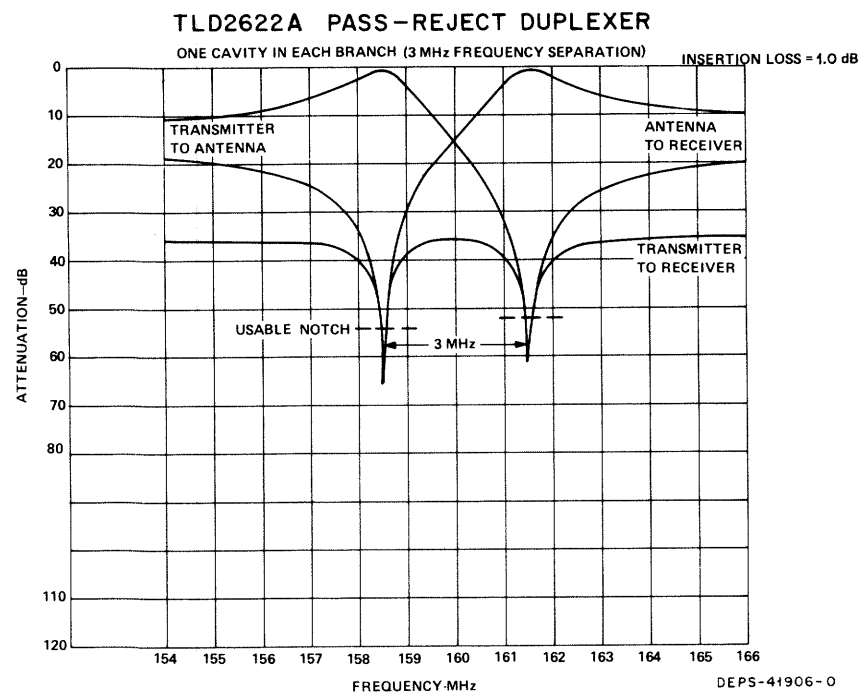
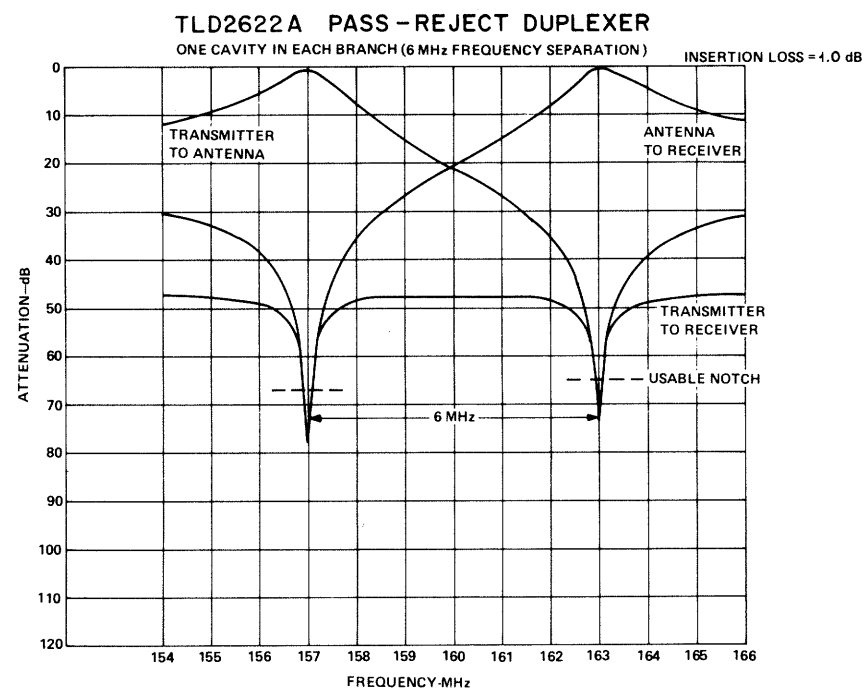

Figure 10. Cavity Internal Construction & Parts Location Detail



CEPS-34642-A



DEPS-41906-0

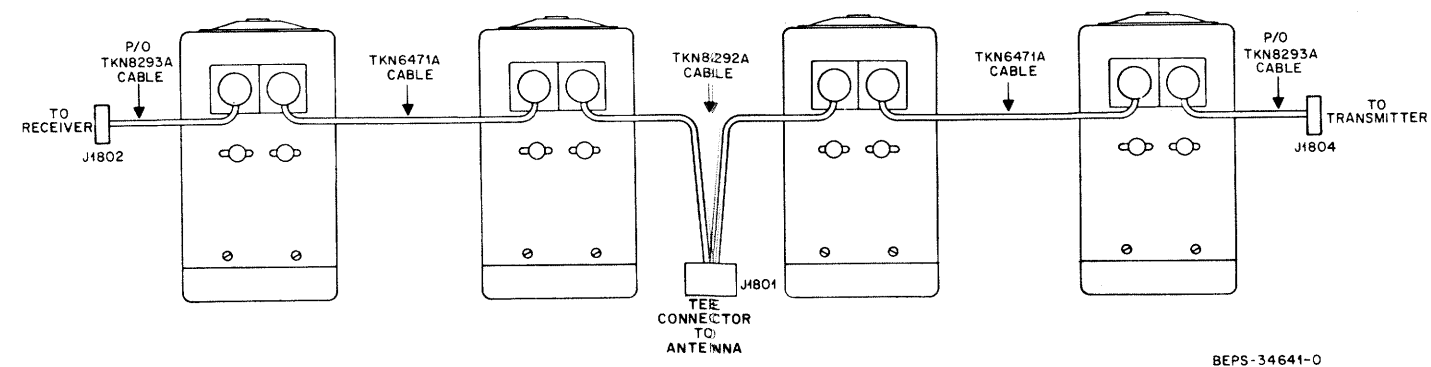

Figure 12. Duplexer Wiring Detail

Figure 11. Duplexer Selectivity Curves





**MOTOROLA INC.**  
Communications  
Sector

## 2-RECEIVER COUPLER

MODEL TRD6270A  
(EIA RACK INSTALLATIONS)

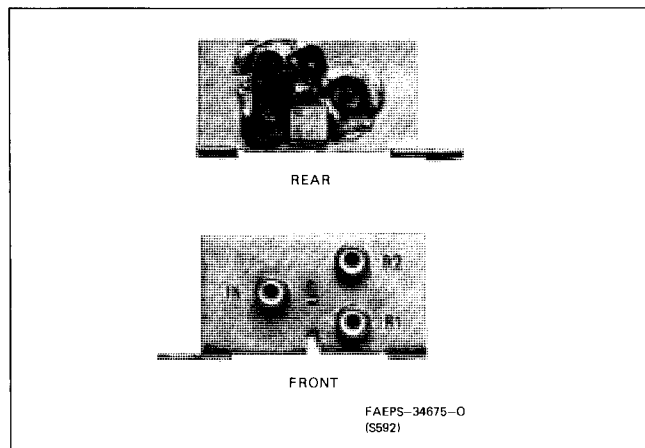

*Figure 1.*  
*2-Receiver Coupler Front and Rear View*

### 1. ELECTRICAL DESCRIPTION

This unit allows two receivers to operate from a single antenna source without interaction. It provides a correct impedance match between both receivers and the antenna source, and also provides isolation between the two receivers. Signal coupling and impedance matching is accomplished by utilizing two transformers and a resistor. A capacitor in the coupler partially cancels the

circuit inductance and thereby makes the circuit appear resistive.

### 2. PHYSICAL DESCRIPTION

The 2-receiver coupler, consisting of a bracket which mounts the electrical components and three cable connectors, is mounted on a chassis installed in the base station. When the coupler is used, the input to the receiver is disconnected and reconnected to the IN connector on the coupler. Coupler cable W1 connects between the R1 coupler connector and the receiver module input connector J201. Coupler cable W2 connects between the R2 coupler connector and the second receiver module input connector J301.

### 3. INSTALLATION

Step 1. Seat the two screws (3-135841) from the outside of the radio, in the two holes located on the back of the EIA rack. These screws are the mounting studs that the mounting bracket mount to.

Step 2. Slide spacers (43-84882N01) and screw nuts (2-121841) on each stud four turns.

Step 3. Align the assembled TRD6270A 2-Receiver Coupler on mounting screws by placing the mounting bracket over the screws and sliding it to the right.

Step 4. Tighten the nuts.

**technical writing services**

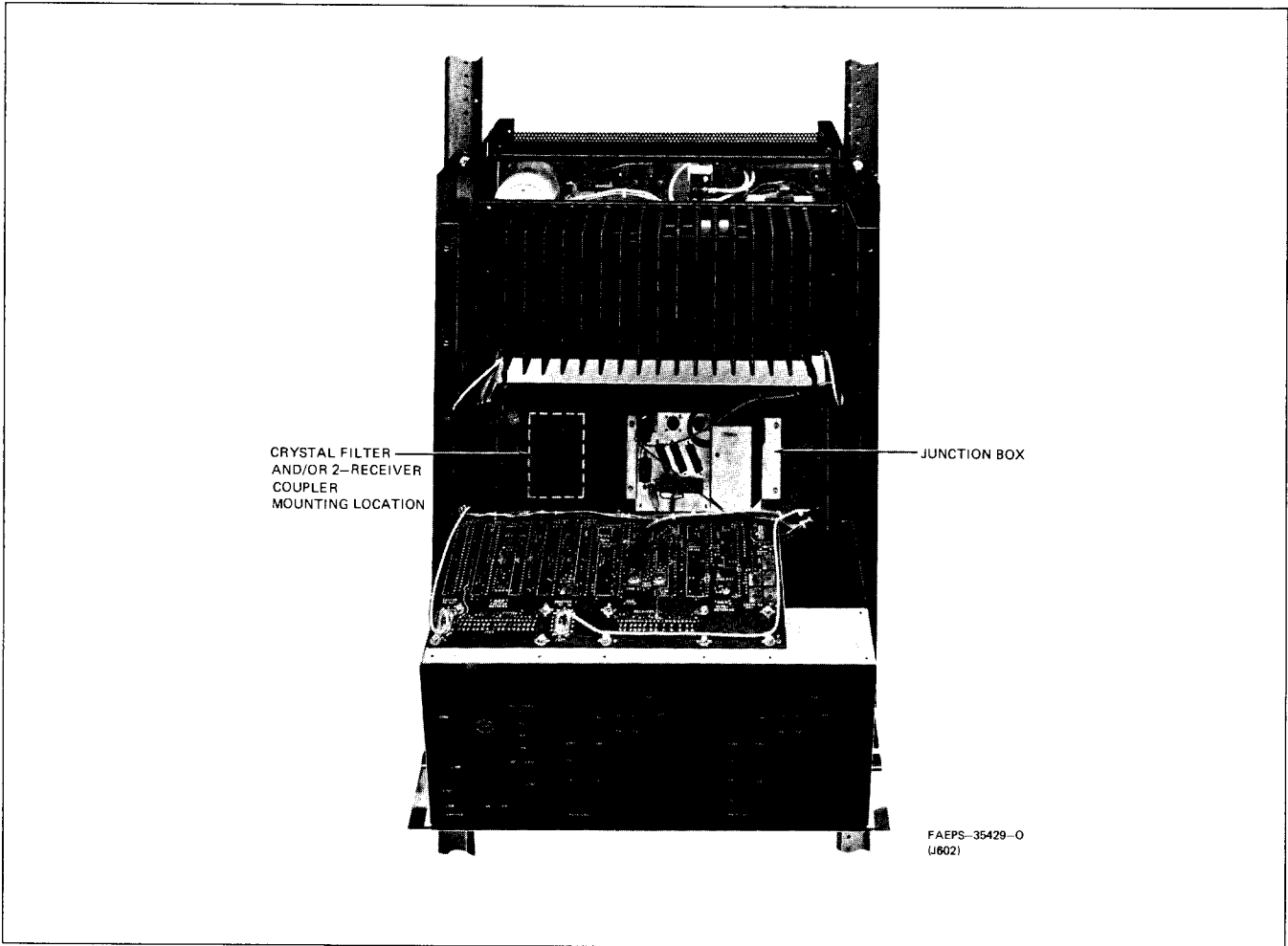

*Figure 2.*  
*2-Receiver Coupler Installed Location*

# EIA RACK INSTALLATION SCHEMATIC DIAGRAM & PARTS LIST

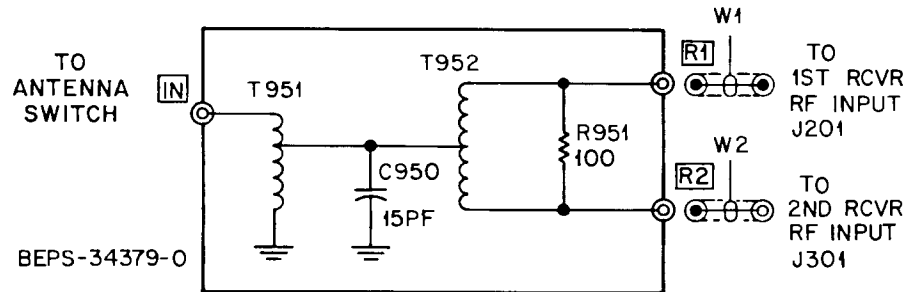

## parts list

TRD6270A 2-Receiver Coupler

PL-8276-B

| REFERENCE SYMBOL            | MOTOROLA PART NO.  | DESCRIPTION   |
|-----------------------------|--|---|
| C950                        | 21-82785H57  | <b>capacitor, fixed:</b><br>15 pF $\pm$ 0.5 pF; 850 V   |
| R951                        | 6-125A25   | <b>resistor, fixed:</b><br>100 $\pm$ 5%; 1 $\frac{1}{2}$ W  |
| T951                        | 24-84130G02  | <b>transformer:</b><br>splitter   |
| T952                        | 24-84130G01  | splitter  |
| W1                          | 1-80763D70<br>30-83794C01<br>28-84282D01                               | <b>cable assembly:</b><br>includes:<br>CABLE, coaxial; 45" long<br>CONNECTOR, plug; single contact type   |
| W2                          | 28-82875N01<br>1-80763D71<br>30-83794C01<br>28-82875N01<br>28-82331G01 | PLUG, board mount; phono type<br>includes:<br>CABLE, coaxial; 40" long<br>PLUG, board mount; phono type<br>CONNECTOR, plug; single contact type |
| <b>non-referenced items</b> |  |   |
|                             | 1-80737B78   | ASSEMBLY, splitter board  |
|                             | 2-131435   | NUT, 4-40 $\times$ 1/4"; 2 used   |
|                             | 3-134186   | SCREW, thread forming: 6-32 $\times$ 5/16"; 2 used  |
|                             | 3-135500   | SCREW, machine: 4-40 $\times$ 1/4"; 2 used  |
|                             | 7-83020N01   | BRACKET, coupler  |
|                             | 42-10217A02  | STRAP, tie; 6 used  |
|                             | 42-82143C05  | CLIP, cable   |
|                             | 42-82143C08  | CLIP, cable   |
|                             | 42-82143C09  | CLIP, cable; 2 used   |
|                             | 3-135841   | SCREW, thread forming: 6-32 $\times$ 7/8"; 2 used   |
|                             | 2-121841   | NUT, locking: 6-32; 2 used  |
|                             | 43-84882N01  | SPACER, 7/16; 2 used  |



**MOTOROLA INC.**  
Communications  
Sector

## 2-RECEIVER COUPLER MODEL TRD6210A

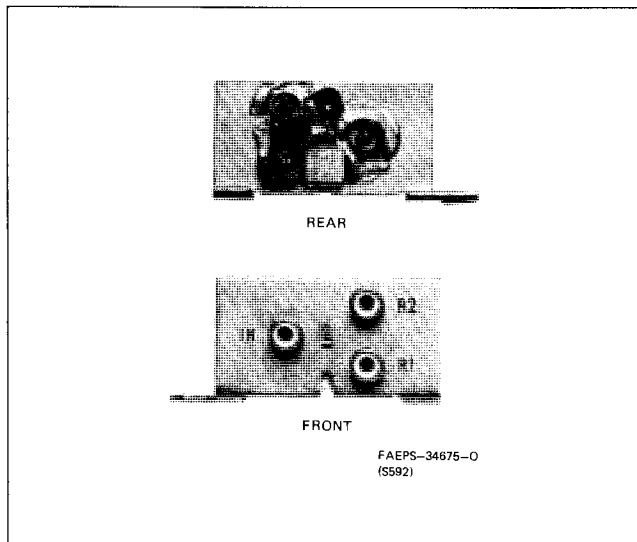

*Figure 1.*  
*2-Receiver Coupler Front and Rear View*

### 1. ELECTRICAL DESCRIPTION

This unit allows two receivers to operate from a single antenna source without interaction. It provides a correct impedance match between both receivers and the antenna source, and also provides isolation between the two receivers. Signal coupling and impedance matching is accomplished by utilizing two transformers and a resistor. A capacitor in the coupler partially cancels the circuit inductance and thereby makes the circuit appear resistive.

### 2. PHYSICAL DESCRIPTION

The 2-receiver coupler, consisting of a bracket which mounts the electrical components and three cable connectors, is mounted on a chassis installed in the base

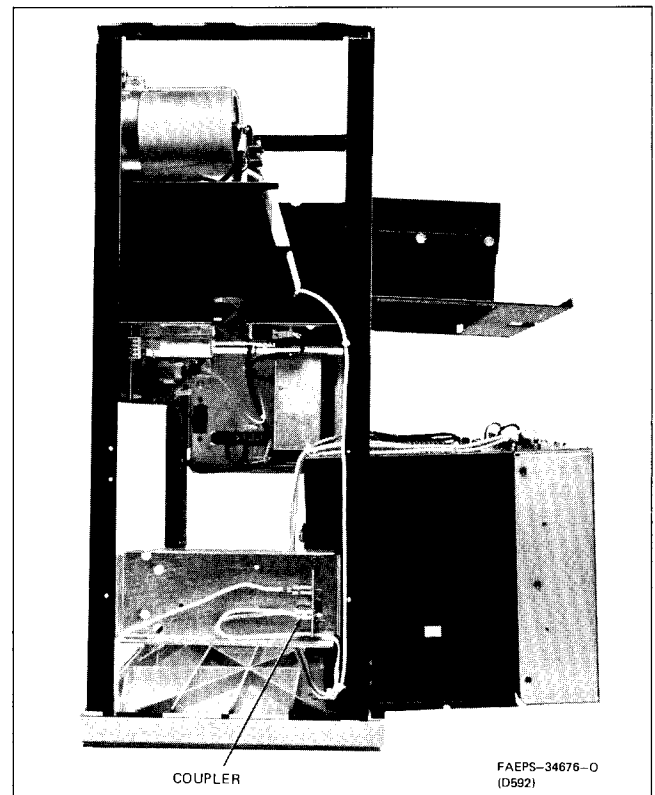
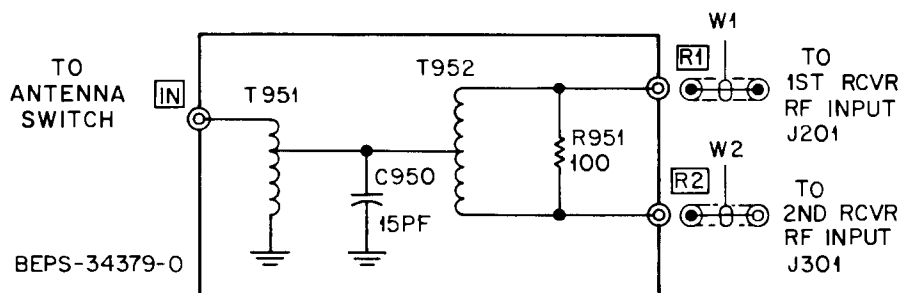

*Figure 2.*  
*2-Receiver Coupler Installed Location*

station. When the coupler is used, the input to the receiver is disconnected and reconnected to the IN connector on the coupler. Coupler cable W1 connects between the R1 coupler connector and the receiver module input connector J201. Coupler cable W2 connects between the R2 coupler connector and the second receiver module input connector J301.

**technical writing services**

# SCHEMATIC DIAGRAM & PARTS LISTS



## parts list

TRD6210A 2-Receiver Coupler

PL-8008-A

| REFERENCE SYMBOL            | MOTOROLA PART NO.  | DESCRIPTION   |
|-----------------------------|--|---|
| C950                        | 21-82785H57  | 15 pF $\pm$ 0.5 pF; 850 V   |
| R951                        | 6-125A25   | <b>resistor, fixed:</b><br>100 $\pm$ 5%; 1/2 W  |
| T951                        | 24-84130G02  | <b>transformer:</b><br>splitter   |
| T952                        | 24-84130G01  | splitter  |
| W1                          | 1-80736D03<br>30-83794C01<br>28-84282D01                               | <b>cable assembly:</b><br>includes:<br>CABLE, coaxial; 31" long<br>CONNECTOR, plug; single contact type   |
| W2                          | 28-82875N01<br>1-80736D04<br>30-83794C01<br>28-82785N01<br>28-82331G01 | PLUG, board mount; phono type<br>includes:<br>CABLE, coaxial; 37.5" long<br>PLUG, board mount; phono type<br>CONNECTOR, plug; single contact type |
| <b>non-referenced items</b> |  |   |
|                             | 1-80737B78   | ASSEMBLY, splitter board  |
|                             | 2-131435   | NUT, 4-40 x 1/4"; 2 used  |
|                             | 3-134186   | SCREW, tapping: 6-32 x 5/16"; 2 used  |
|                             | 3-82227A03   | SCREW, machine: 4-40 x 5/16"; 2 used  |
|                             | 7-83020N01   | BRACKET, coupler  |
|                             | 42-10217A02  | STRAP, tie; 7 used  |
|                             | 42-82143C05  | CLIP, cable   |
|                             | 42-82143C08  | CLIP, cable   |
|                             | 42-82143C09  | CLIP, cable; 3 used   |



**MOTOROLA INC.**  
Communications  
Sector

**MSR 2000 BASE STATION  
SERVICE ACCESSORIES**  
TRN5080A DC METERING CHASSIS  
TRN5079A SERVICE INTERCOM  
WITH SPEAKER CHASSIS

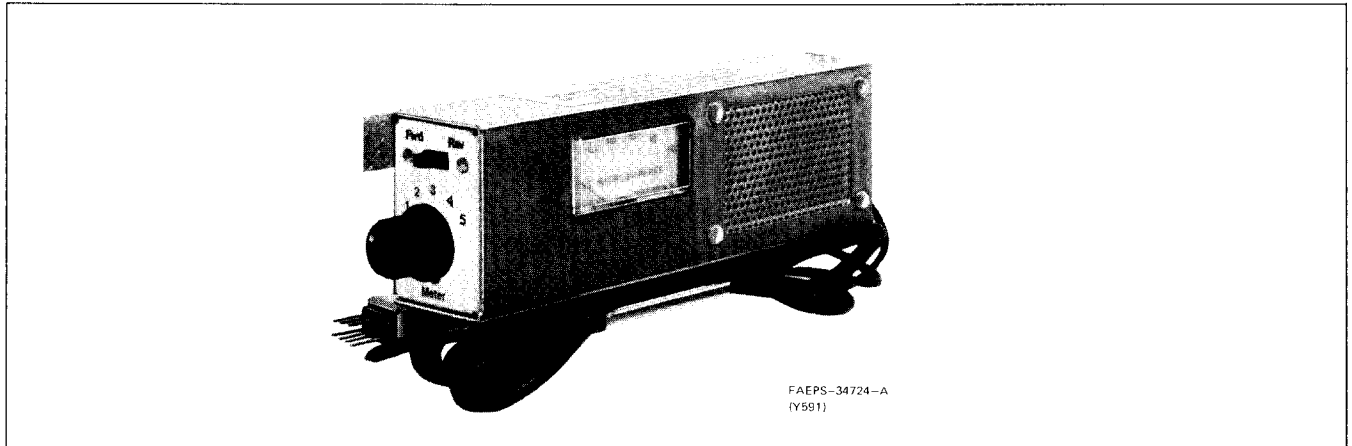

Figure 1. TRN5080A DC Metering Chassis

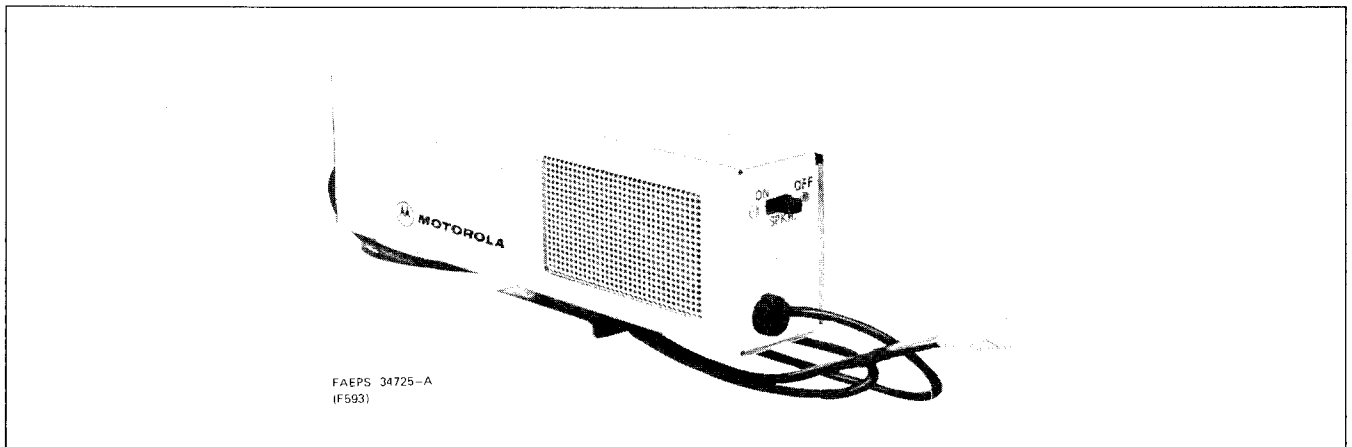

Figure 2. TRN5079A Service Intercom with Speaker Chassis

**technical writing services**  
1301 E. Algonquin Road, Schaumburg, IL 60196

## 1. DESCRIPTION

1.1 The TRN5079A Service Intercom with Speaker Chassis provides a local audio speaker for use in troubleshooting the station, and for intercom use when the station is provided with the intercom option. The TRN5080A DC Metering Chassis provides the same local speaker, and in addition, provides most station metering required for normal servicing and maintenance.

1.2 The meter is a 0-50 uA instrument mounted on the dc metering chassis. A selector switch chooses the specific function to be metered. Every function available at the metering receptacle of the exciter, power amplifier/power control board, and receiver board(s) can be selected for metering. The dc metering chassis is equipped with a connection cable terminated with the standard Motorola 7-pin metering connector, which may be connected to the metering connectors provided in the station.

---

### CAUTION

The TRN5080A DC Metering Chassis must not be connected to control metering connector J2 on the backplane interconnect board. (This connector may be labeled either TEST SET MTR or CONTROL MTR, depending on station model.) Damage to the metering circuit will result. The control metering connector is intended for connection to the Motorola TEK-5 Metering Panel or the S1056-59 Portable Test Set only.

---

## 2. OPERATING INSTRUCTIONS

### 2.1 LOCAL SPEAKER

Press the two-conductor speaker connector onto pins 22 and 23 of the receiver 1 audio board position on the back of the station backplane interconnect board. This connection may be left permanently if desired. The speaker is switched on or off as desired, by changing the position of the SPKR switch.

### 2.2 METERING

Step 1. Connect the metering connector from the dc metering chassis to the desired metering connector in the station. In the Motorola *MSR 2000* station, exciter and receiver metering connectors are both located on the backplane interconnect board. The power amplifier/power control metering connector is located on the power control board. See Caution.

Step 2. Select the meter position required. If the meter deflects in the wrong direction, change the position of the FWD-REV switch.

### NOTE

Refer to the Transmitter and Receiver sections of the station manual for typical meter readings. Also, keep a log of all meter readings each time the station is serviced. Use the last set of readings as a reference, note any degradation of performance.

#### *Meter Polarity Switch Position*

| Board Metered    | Position |
|------------------|----------|
| Receiver         | FWD      |
| Exciter          | REV      |
| PA/Power Control | FWD      |

# SCHEMATIC DIAGRAM & PARTS LISTS

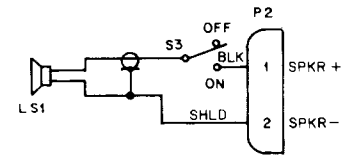
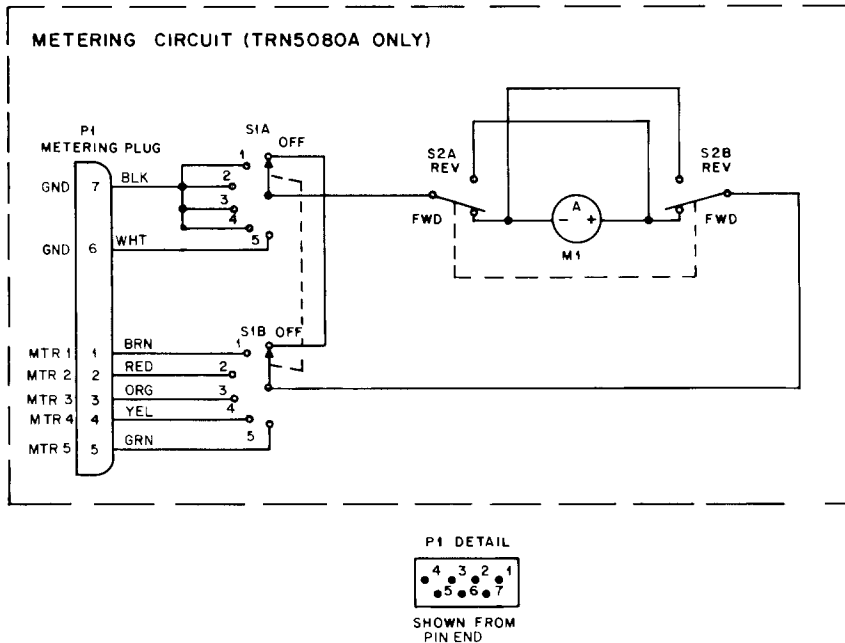

BEPS-34726-0

P2 DETAIL

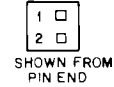

## parts list

TRN5079A Service Intercom with Speaker Chassis  
TRN5080A DC Metering Chassis

PL-8037-A

| REFERENCE SYMBOL        | MOTOROLA PART NO. | DESCRIPTION  |
|-------------------------|-------------------|--|
| LS1                     | 50-82913N01       | <b>speaker:</b><br>8 ohms; 1-3/4 x 3"  |
| M1                      | 72-83319G01       | <b>meter:</b><br>50 uA (TRN5080A)  |
| P1                      | 28-84208B01       | <b>connector, plug:</b><br>male, 7-contact (TRN5080A)<br>housing; 2-position |
| P2                      | 15-83498F38       |  |
| S1                      | 40-82924N01       | <b>switch:</b><br>rotary (TRN5080A)<br>slide, dpdt                           |
| S2, 3                   | 40-83204B01       |  |
| <b>mechanical parts</b> |                   |  |
|                         | 3-124616          | SCREW, tapping; 6-32 x 1/4"; 2 used  |
|                         | 3-136934          | SCREW, tapping; 6-32 x 3/8"; 2 used (TRN5080A)                               |
|                         | 15-82927N01       | COVER  |
|                         | 35-82928N01       | GRILLE   |
|                         | 36-82929N01       | KNOB (TRN5080A)  |
|                         | 42-850861         | RETAINER, cable (TRN5080A)   |
|                         | 42-82018H07       | RETAINER, cable  |
|                         | 29-83499F01       | TERMINAL; 2 used   |
|                         | 30-824275         | CABLE, shielded; 42" used  |
|                         | 15-82926N01       | HOUSING (TRN5080A)   |
|                         | 3-129674          | SCREW, machine; 4-40 x 3/16"; 2 used (TRN5080A)                              |
|                         | 3-132341          | SCREW, machine; 4-36 x 1/4"; 2 used (TRN5080A)                               |
|                         | 15-83947K01       | COVER; 2 used (TRN5080A)   |
|                         | 30-83678K01       | CABLE, 7-conductor; 42" used (TRN5080A)                                      |
|                         | 42-83948K01       | CLIP; 2 used (TRN5080A)  |
|                         | 15-82926N02       | HOUSING (TRN5079A)   |
|                         | 5-10281A05        | RIVET; 4 used  |
|                         | 14-84717F01       | INSULATOR (used on TRN5080A only)  |





**MOTOROLA INC.**

Communications  
Sector

# MSR 2000™ BASE (RA), REPEATER (RA), & GUARD TONE KEYING CONFIGURATIONS

OPTION C150, C160, AND C170 SERIES

## 1. DESCRIPTION AND APPLICATION

### 1.1 INTRODUCTION

1.1.1 The options described in this instruction section are designed to provide for the remote control of a base station which, because of its location, cannot be economically connected via a wire line pair to the control point. Mountain top sites or locations in uninhabited regions (where no telephone lines exist) are typical examples of base station sites which need to be controlled using specialized radio equipment instead of a wire line pair.

1.1.2 By definition, an "RA" link (part of a "radio repeater (RA) system") is the radio equipment required to replace the usual wire-line control when operating a remote base station from its control point. The remote base station is termed an RA base. The repeater station that controls the RA base is called an RA repeater. It is co-located with the RA base and interconnected by a single, multi-conductor cable (customer supplied). A console and/or control station is located where the normal dispatch operations are carried out. See Figures 1 and 2.

1.1.3 RA links usually operate on 72 MHz, 450 MHz, or 960 MHz. Within the United States, the Federal Communications Commission (FCC) has certain restrictions making it difficult to license a 72 MHz RA link within 80 miles of a channel 4 or 5 TV station, or a UHF RA link within 75 to 100 miles of a metropolitan area with a population 200,000 or more.

### 1.2 BASE (RA) OPTION C150

1.2.1 The base (RA) option C150 can be used with all *MSR 2000*, single receiver, dc or tone remote control base station models in the 132-174 MHz, or 450-512 MHz frequency bands. The base (RA) option cannot be used with repeater (RT) models.

1.2.2 The *MSR 2000* base (RA) station may be connected to an RA link made up of *MICOR* stations. Refer to the Interconnect Diagrams provided at the end of this section.

1.2.3 The base (RA) option adds a squelch gate module which keys the companion repeater (RA) station when a message is received at the base (RA) station. The squelch gate module provides a PTT function

MSR 2000 and Micor are trademarks of Motorola, Inc.

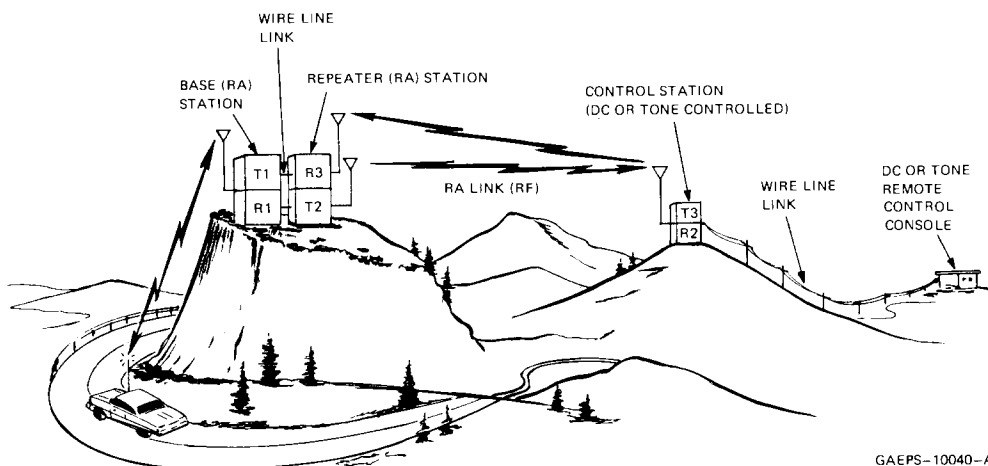

GAEPS-10040-A

Figure 1. Typical Repeater (RA) System

OPTION C150, C160, AND C170 SERIES

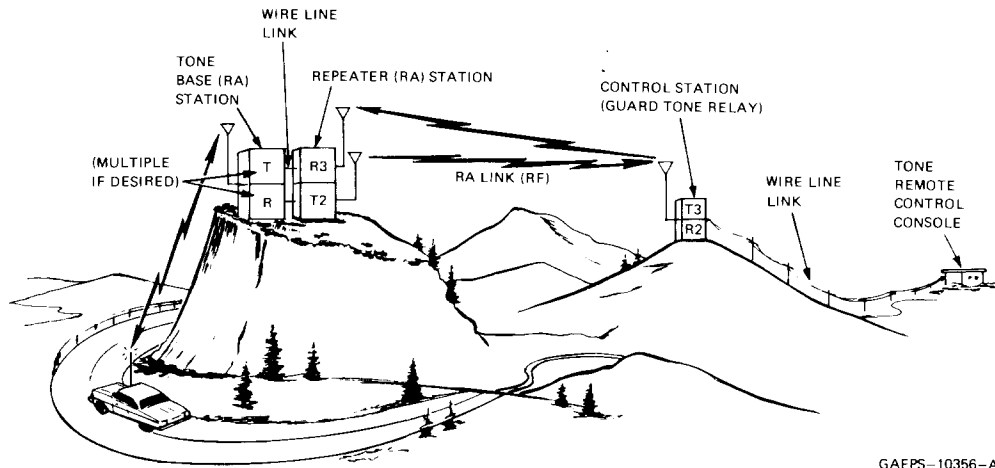

Figure 2. Typical Guard Tone Relay System

(switched ground) to the repeater (RA) station when the receiver in the base (RA) station quiets (receives a message).

1.2.4 When the station is converted for base (RA) operation, separate wire-line remote control is not required. Control is via rf from the control dispatch point or mobile with the control point given priority. This does not involve further model complement change concerning tone remote control models, but does remove the dc transfer module in dc remote control models.

1.2.5 RA link equipment (Base (RA)-Repeater (RA) stations) is used in two basic systems — “Repeater (RA) Systems” and “Guard Tone Relay Systems.” Both systems are used where extended range operation is required, or where natural or man made limitations to direct communications are encountered.

### 1.3 REPEATER (RA) OPTION C160

1.3.1 The repeater (RA) option C160 may be used with either *MSR 2000* or Micor™ 450-512 MHz repeater (RT) models (PL or carrier squelch). Note that either a duplexer or separate receive and transmit antennas are required on an RA repeater station to satisfy FCC rules and regulations for dispatcher priority.

1.3.2 A repeater (RA) station in conjunction with a base (RA) station and two or more remote stations, such as a mobile station and a control station, together form a “radio repeater (RA) system”. See Figure 1.

1.3.3 The repeater (RA) - base (RA) combination has two modes of operation. It can: (1) receive and re-transmit a message from a control station to a mobile station; and, (2) receive and re-transmit a message from a mobile station to a control station.

1.3.4 The mobile units and the base (RA) station operate on frequency F1. The repeater (RA) station transmits on frequency T2 and receives on frequency R3. The control station transmits on frequency T3 and receives on frequency R2.

1.3.5 When the control station calls the mobile unit, the repeater (RA) turns on the base (RA) station transmitter. When receiver quieting of the repeater (RA) station reaches a predetermined level, the squelch gate in the repeater (RA) station actuates. This keys the transmitter in the base (RA) station. Audio is routed from the repeater (RA) station’s receiver to the base (RA) station’s transmitter audio input. The control station (dispatcher’s) message is then sent to the mobile units on frequency T1 by the base (RA) station’s transmitter.

1.3.6 When a mobile station calls the control station (dispatcher), the base (RA) station turns on the repeater (RA) station’s transmitter. (When receiver quieting of the base (RA) stations reaches a predetermined level, the squelch gate in the base (RA) station actuates. This keys the transmitter in the repeater (RA) station.) Audio is routed from the base (RA) station’s receiver to the repeater (RA) station’s transmitter audio input. The mobile station’s message is then sent to the control station on frequency T2 by the repeater (RA) station’s transmitter.

1.3.7 The control station has operational priority of the base (RA) station. The dispatcher can seize control of the RA system even through a mobile transmission is in process. The control station transmits on T3. Repeater (RA) receiver (R3) is always fully operational, and will, when its receiver quieting reaches a predetermined level, cause the base (RA) station to key, over-riding the mobile.

## 1.4 GUARD TONE RELAY OPTION C170

1.4.1 A guard tone relay system is much like the usual "RA" system -- with greatly expanded control capability.

1.4.2 In the repeater (RA) system (refer to Figure 1) a received message at the repeater (RA) station actuates the squelch gate in that station. This keys the companion base (RA) station which retransmits the message to mobile units. Only transmitter turn-on and turn-off control of the base (RA) station is possible in a repeater (RA) system, determined by receiver quieting and the squelch gate module in the repeater (RA) station.

1.4.3 In the guard tone relay system (see to Figure 2), the presence of an rf signal *alone* at the repeater (RA) station does NOT cause the companion station to transmit. Instead, the companion station is controlled via tone signals, just as if it were connected directly to a remote control console by wire lines. This permits multiple frequency operation, PL disable (PL or DPL coded squelch models), unique function commands, etc., of the companion base (RA) station.

1.4.4 For example, should the tone remote control console operator (dispatcher) want to talk to a mobile unit on frequency T4, a high level guard tone signal burst is applied to the control station. The control station keys *immediately* on frequency T3 and transmits the remaining *guard tone* signal to the repeater (RA) station. The repeater (RA) station applies this high level guard tone signal to the audio input of the companion tone remote control base (RA) station, which is then ready to accept and react to the forthcoming T4 function tone. The flexibility and number of functions in the guard tone relay system is limited only by the sophistica-

tion of the companion tone remote control base (RA) station and the remote control console. It should be noted that a squelch gate is used in the repeater (RA) station in this guard tone application to provide a transmitter channel element ground when the station is keyed. This is necessary since neither an F1-CS (carrier squelch) or F1-PL control module is used, which would otherwise supply the ground. The squelch gate is NOT used to key the companion base (RA) station.

### NOTE

The transmit time of the high level guard tone burst sent by the remote control console should be lengthened to compensate for the delay time encountered in the keying of the guard tone relay station. Refer to the tone remote control console instruction manual for details.

## 2. CONNECTIONS BETWEEN BASE (RA) AND REPEATER (RA) STATIONS

The base (RA) station is connected to a companion repeater (RA) station via a single, multi-conductor cable (customer supplied). Since the cable is normally short and within the same installation site room, the usual telephone company line restrictions do not apply; adjust audio levels at +14 dBm. Control functions are also carried by direct connections. Connect the base (RA) station to the companion repeater (RA) station. Refer to Interconnect Diagrams provided at the end of this section.

### NOTE

Antenna and power connections are not changed by the use of the base (RA) conversion.

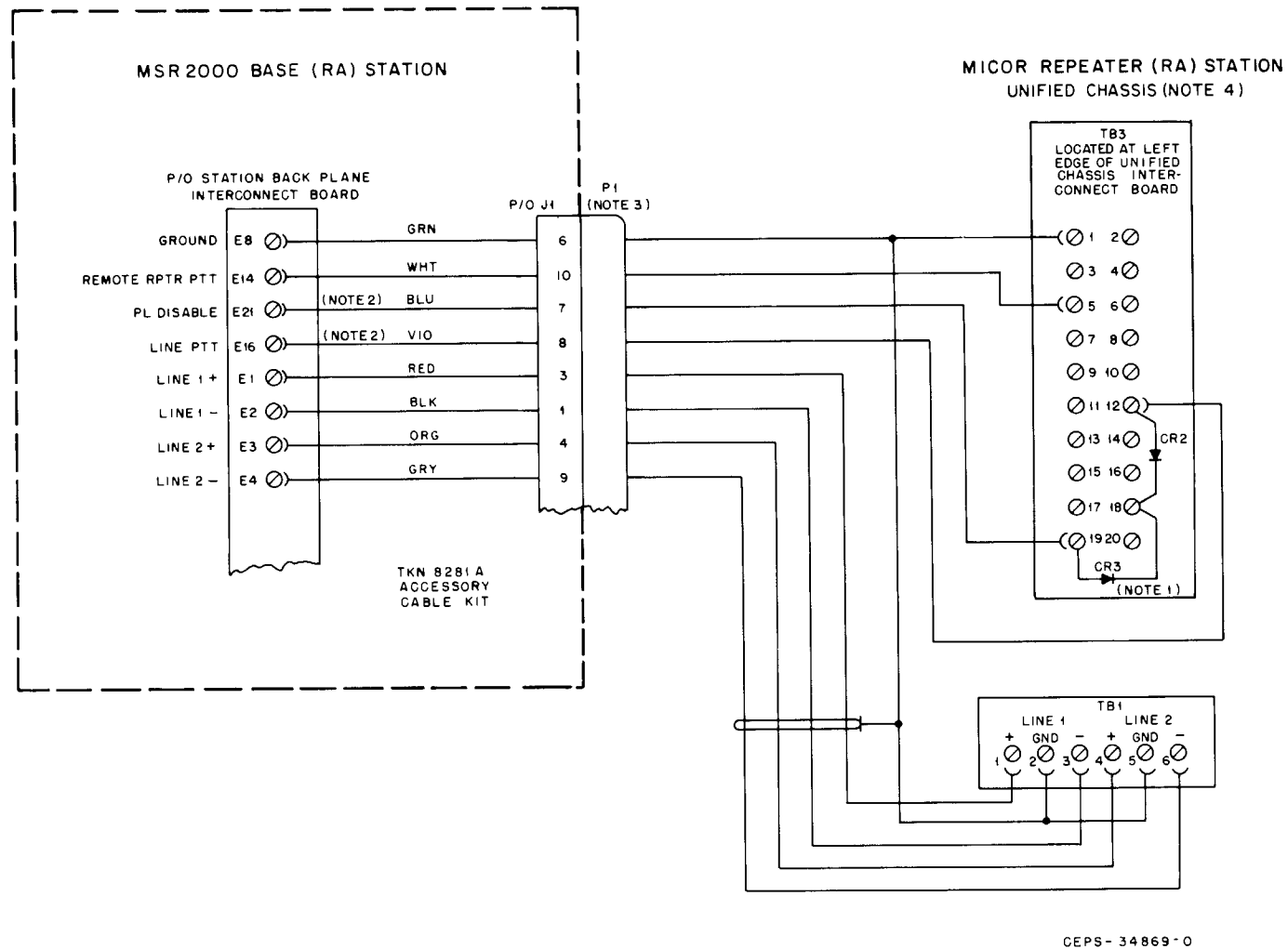

**CAUTION**  
REMOVE DIODE CR15 AND RESISTOR R59 IN SQUELCH GATE MODULES OF BOTH STATIONS WHEN RELAY K1 IS NOT USED.

- NOTES:**
- IF PL/DPL DISABLE IS REQUIRED, CR2 AND CR3 (MOTOROLA PART NO. 48-82392 B03) SHOULD BE INSTALLED ON THE REPEATER (RA) STATION. THE 5-SECOND JUMPER (JU1) IN THE SINGLE TONE DECODER MODULE MUST BE REMOVED.
  - "LINE PTT" AND "PL DISABLE" LINES ARE NOT CONNECTED IN GUARD TONE RELAY APPLICATIONS.
  - CONNECTOR P1 IS SUPPLIED WITH MSR 2000 BASE (RA) STATION, AS PART OF TKN 8281A KIT. INTERSTATION CABLING IS NOT SUPPLIED.
  - FOR REPEATER (RA) STATIONS OTHER THAN SHOWN REFER TO APPROPRIATE REPEATER (RA) STATION MANUAL. INTERCONNECT MATCHING FUNCTIONS.

CEPS-34869-0

### parts list

TKN8281A Auxiliary Interconnect Cable PL-8087-O

| REFERENCE SYMBOL        | MOTOROLA PART NO. | DESCRIPTION                               |
|-------------------------|-------------------|---|
| J1                      | 9-84538E03        | connector, receptacle: female; 25-contact |
| <b>mechanical parts</b> |                   |   |
|                         | 2-84586C01        | NUT, machine; 4-40; square; 2 used        |
|                         | 3-129674          | SCREW, machine; 4-40 x 3/16"; 2 used      |
|                         | 29-812979         | LUG, crimp terminal; 10 used              |
|                         | 42-10217A02       | STRAP, tie; 12 used                       |
|                         | 30-86970A02       | CABLE; 10 conductor; 46" used             |
|                         | 43-10646A09       | SPACER; 2 used                            |
|                         | 28-84506E08       | CONNECTOR, male; 25-contact               |
|                         | 15-82486M01       | HOOD                                      |

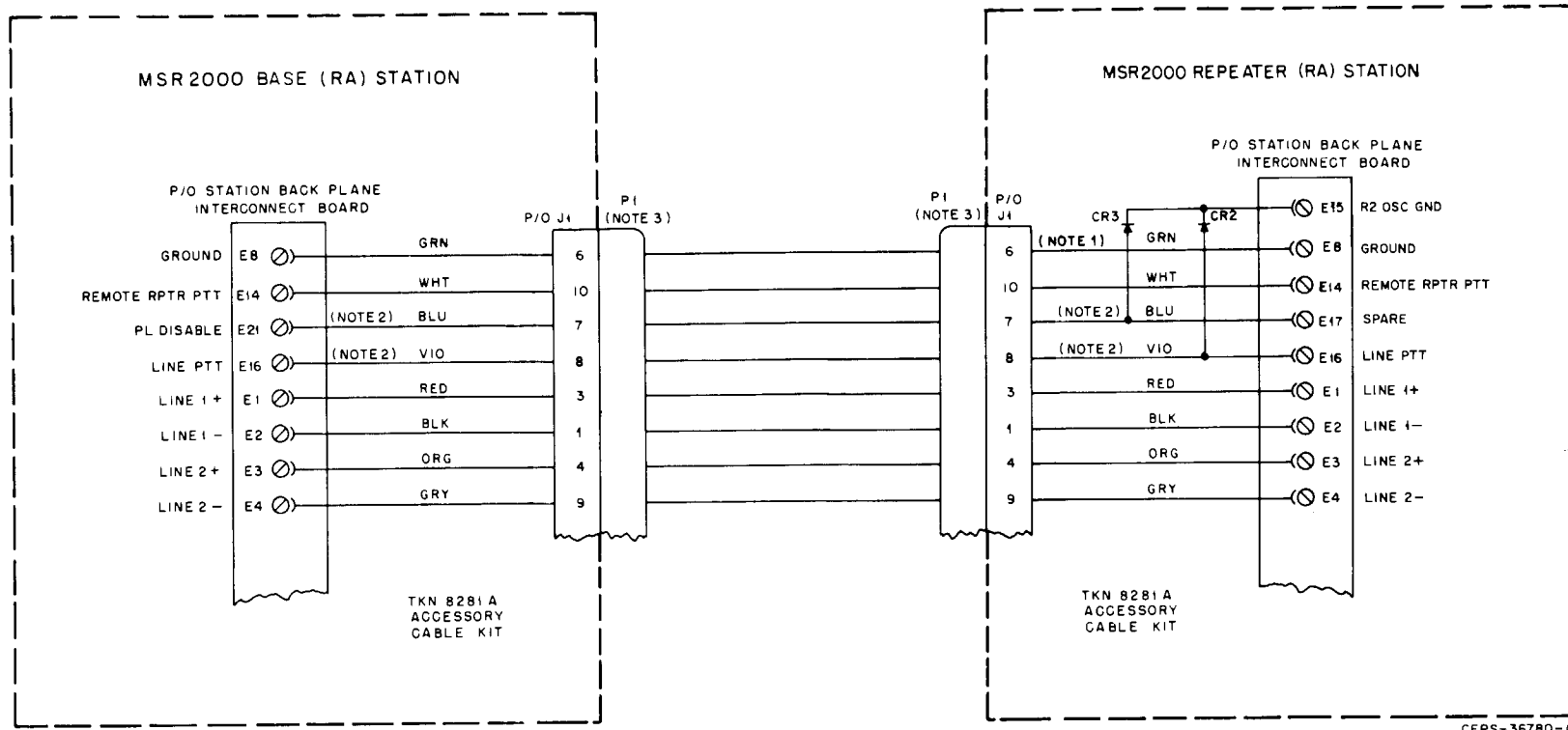

**CAUTION**  
REMOVE DIODE CR15 AND RESISTOR R59 IN SQUELCH GATE MODULES OF BOTH STATIONS WHEN RELAY K1 IS NOT USED.

- NOTES:**
- IF PL/DPL DISABLE IS REQUIRED, CR2 AND CR3 (MOTOROLA PART NO. 48-82392 B03) SHOULD BE INSTALLED ON THE REPEATER (RA) STATION. THE 5-SECOND JUMPER (JU1) IN THE SINGLE TONE DECODER MODULE MUST BE REMOVED.
  - "LINE PTT" AND "PL DISABLE" LINES ARE NOT CONNECTED IN GUARD TONE RELAY APPLICATIONS.
  - CONNECTOR P1 IS SUPPLIED WITH EACH MSR 2000 RA STATION, AS PART OF TKN 8281A KIT. INTERSTATION CABLING IS NOT SUPPLIED.

CEPS-36780-0

Base (RA) To Repeater (RA)  
Station Interconnect Diagrams and Parts List  
Motorola No. PEPS-37325-O  
8/19/83-UP

OPTION C150, C160, AND C170 SERIES

# DYNAMIC MICROPHONE

MODEL TMN6054A

## electrical parts list

**important**  
Use *only* the following Motorola part numbers when ordering replacement parts.

| REFERENCE SYMBOL            | MOTOROLA PART NO.                               | DESCRIPTION   |
|-----------------------------|---|---|
| DP1                         | 59-83272G01<br>or 59-84013A01<br>or 59-82933C02 | <b>cartridge, microphone:</b><br>dynamic; includes transistor preamplifier  |
| P1103                       | —   | <b>connector, plug:</b><br>part of W1   |
| W1                          | 30-83731M01                                     | <b>cord, microphone; coiled:</b><br>4-conductor; includes ref. part P1, CLAMP, cable "S" hook (ref. part 13), SPRING, strain relief (ref. part 12), and non-ref. LUG (4 req'd.) 29-83277G02 |
| S1                          | 40-82263G02                                     | <b>switch, push:</b><br>dpst  |
| <b>non-referenced items</b> |   |   |
|                             | 29-83277G02                                     | LUG, insulation piercing: 4 req'd. (p/o W1)   |
|                             | 33-82599D01                                     | NAMEPLATE   |
|                             | 13-84599B01                                     | EMBLEM  |

## mechanical parts list

| CODE | MOTOROLA PART NO. | DESCRIPTION  |
|------|-------------------|--|
| 1    | 38-84559B01       | PUSHBUTTON   |
| 2    | 3-140000          | SCREW, tapping: no. 6-19 x 3/8"; 3 req'd.                        |
| 5    | 3-122830          | SCREW, tapping: no. 8 x 1/2"; 2 req'd.                           |
| 6    | 1-80707T05        | BRACKET & SPRING ASSY. (eyeletted)                               |
| 7    | 1-80709B93        | HOUSING, microphone (front and rear)                             |
| 8    | 3-129498          | SCREW, lock: no 6-32 x 5/16"; "Phillips" round head              |
| 9    | 4-7666            | LOCKWASHER: no. 6 external                                       |
| 10   | 42-852710         | STRAP, strain relief   |
| 11   | 3-139999          | SCREW, tapping: no. 6-19 x 3/4"; "Phillips" round head; 2 req'd. |
| 12   | 41-852707         | SPRING, strain relief (p/o W1)                                   |
| 13   | 42-893647         | CLAMP, cable "S" hook (p/o W1)                                   |
| 15   | 42-82702B02       | RETAINER, cartridge  |
| 16   | 32-82703B01       | GASKET, neoprene   |
| 17   | 11-2506           | TUBING, no. 9 black; 5" length req'd.                            |

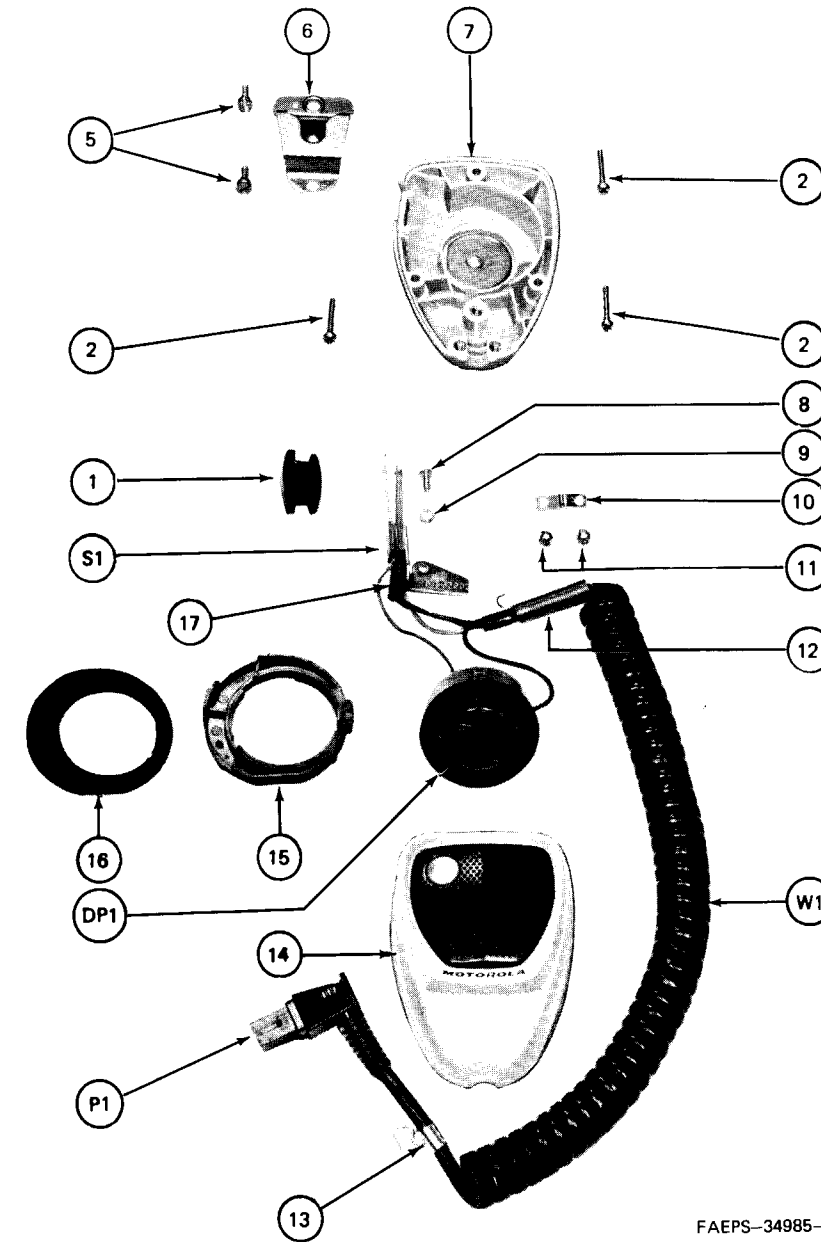

FAEPS-34985-0

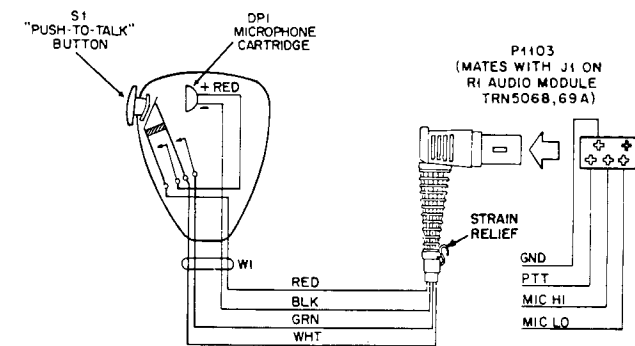

AEPS-34913-0

68P81062E39-0

7/12/82 -UP

END OF DOCUMENT