



MOTOROLA INC.

Communications
Sector

MSR 2000™ UHF PREAMPLIFIER

FIELD INSTALLED OPTION MODEL TLE2403A
FACTORY INSTALLED OPTION MODEL C12AJ

1. INTRODUCTION

The UHF preamplifier is an optional accessory that improves receiver sensitivity of the *MSR 2000* Base Station. This manual describes the hardware, installation, theory of operation, and maintenance of the preamplifier for the *MSR 2000* 1 and 2-receiver base stations.

2. DESCRIPTION

The TLE2403A Preamplifier Field Installed Kit or Factory Installed Option C12AJ consist of a TRN9168A Antenna Relay, and a TLE2393A UHF Preamplifier. The preamplifier contains input filtering and matching, and single stage low noise bipolar transistor, and control and protection circuitry. The preamplifier printed circuit board is mounted in a metal housing. A rear cover with an angled mounting slot is fastened to the back of the chassis housing, via 8-screws. This rear cover provides easy access to the printed circuit board and holds the preamplifier to the base station. The housing also contains an input connector labeled IN (J102) and an output connector labeled OUT (J101). Preamplifier power and control is connected to the KEYED A-, and A+ lines, via two feed-through capacitors. Refer to Figures 1 and 2.

3. FIELD INSTALLATION INSTRUCTIONS

(Refer to Figures 1 through 4.)

The following describes the field installation of the TLE2403A Preamplifier into the *MSR 2000* 1 or 2-receiver base station. Installation of the antenna switch is described in the attached section 68P81064E84.

Step 1. For later reference, pay close attention to how the transmitter and receiver rf cables are routed to the antenna relay.

Step 2. Remove TRN5864A Antenna Relay, and install TRN9168A Antenna Relay. Route transmitter cable exactly as before.

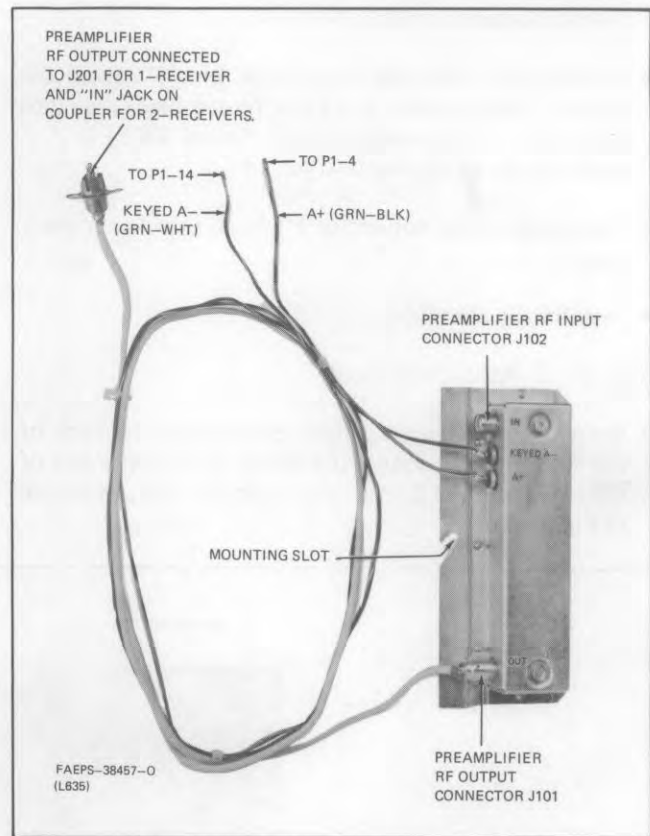

Figure 1. UHF Preamplifier

Step 3. Plug the receiver cable (P102) from TRN9168A Antenna Relay into the IN input connector (J102) of the preamplifier.

PERFORMANCE SPECIFICATIONS

Operating Frequency	440-520 MHz
Power Gain	10 dB min.
Noise Figure	3.5 dB max.
Temperature Range	-30 °C to +60 °C
Size	12.70cm (5")H × 5.72cm (2-1/4")W × 2.54cm (1")D
Termination Connectors	Phone Female

Step 4. Start threads of the mounting screw in the right rear rail of the station (see Figures 3 and 4).

Step 5. Hook the angled mounting slot of the preamplifier into the screw, and tighten the screw to secure the preamplifier.

Step 6a. 1-Receiver Station

- Route A +, KEYED A –, and the rf output cables along the bottom of the station, until they meet with the station's main cable. Tie wrap where necessary.
- Plug the rf output cable connector P201 into the receiver connector J201.
- Unplug the main cable connector plug P1 from the mother board. Insert A + cable (green-black) lug into pin 4 slot of the connector P1. Insert KEYED A – cable (green-white) lug into pin 14 slot.
- Plug main cable connector P1 back into the mother board.
- Installation complete.

Step 6b. 2-Receiver Station

- Route preamplifier rf output cable along the back of the station and connect the phone plug at the end of the cable into the 2-receiver coupler IN jack, as shown in Figure 4.

- Route A +, and KEYED A – cables along the bottom of the station, until they meet with station's main cable. Tie wrap where necessary.

- Unplug the main cable connector P1 from the mother board. Insert A + cable (green-black) into the pin 4 slot of connector P1. Insert KEYED A – cable (green-white) into the pin 14 slot.

- Plug station main cable connector P1 back into the mother board connector.

- Installation complete.

4. THEORY OF OPERATION

(Refer to Schematic Diagram.)

4.1 The receive port of the antenna switch is connected to the input (J102) of the preamplifier. The received signal from the antenna travels through a high pass filter into transistor Q125, a low noise bipolar class A rf amplifier. Next the signal travels through the output network which matches Q125 to 50-ohms output impedance. This output (J101) is connected to the rf input of the receiver. Q126 is a current source which supplies current to Q125.

4.2 Transistors Q127 and Q128 are switches which turn the rf preamplifier on or off. In the receive mode, KEYED A – is high (+13.8 V). This turns on Q128

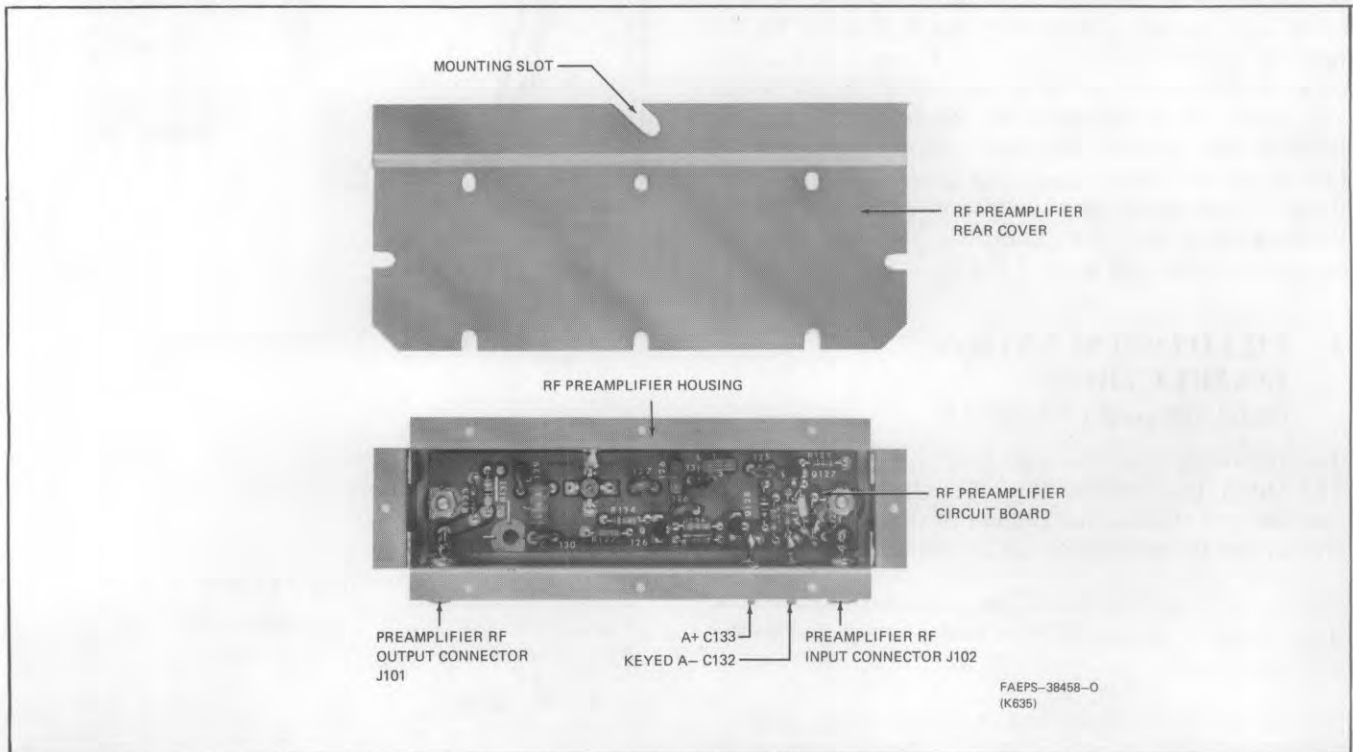

Figure 2. UHF Preamplifier Rear View with Rear Cover Removed

which provides forward bias to Q126 and Q125, and the rf preamplifier is turned on. In the transmit mode, KEYED A - is low (0 V). Transistor Q128 is turned off thus removing bias from Q125 and Q126. Q127 is turned on. Q127 forward biases CR125, which allows rf signals to pass through CR125 and C128 to ground. This prevents high level rf signals from damaging Q125 during transmit.

5. MAINTENANCE

This section provides troubleshooting procedures for the preamplifier. Poor sensitivity and improper voltage levels are generally the result of a malfunction. The following procedure checks the preamplifier for poor sensitivity.

Step 1. Measure receiver sensitivity without the preamplifier.

Step 2. If receiver sensitivity is within specifications, then check rf cables for excessive loss.

Step 3. If no excessive loss can be detected then check the dc voltages provided in Table 1. It lists proper voltage levels for components on the circuit board.

Table 1. DC Voltage Levels

Where Measured	Receive Mode	Transmit Mode
A + Feedthru Capacitor	+13.8 V	+13.8 V
Keyed A - Feedthru Capacitor	+13.8 V	0 V
Emitter Q128	+9.5 V	0 V
Collector Q127	0 V	+10 V
Collector Q125	+8.7 V	0 V
Cathode CR125	0 V	+9 V

Note: If voltages are ok, then replace Q125.

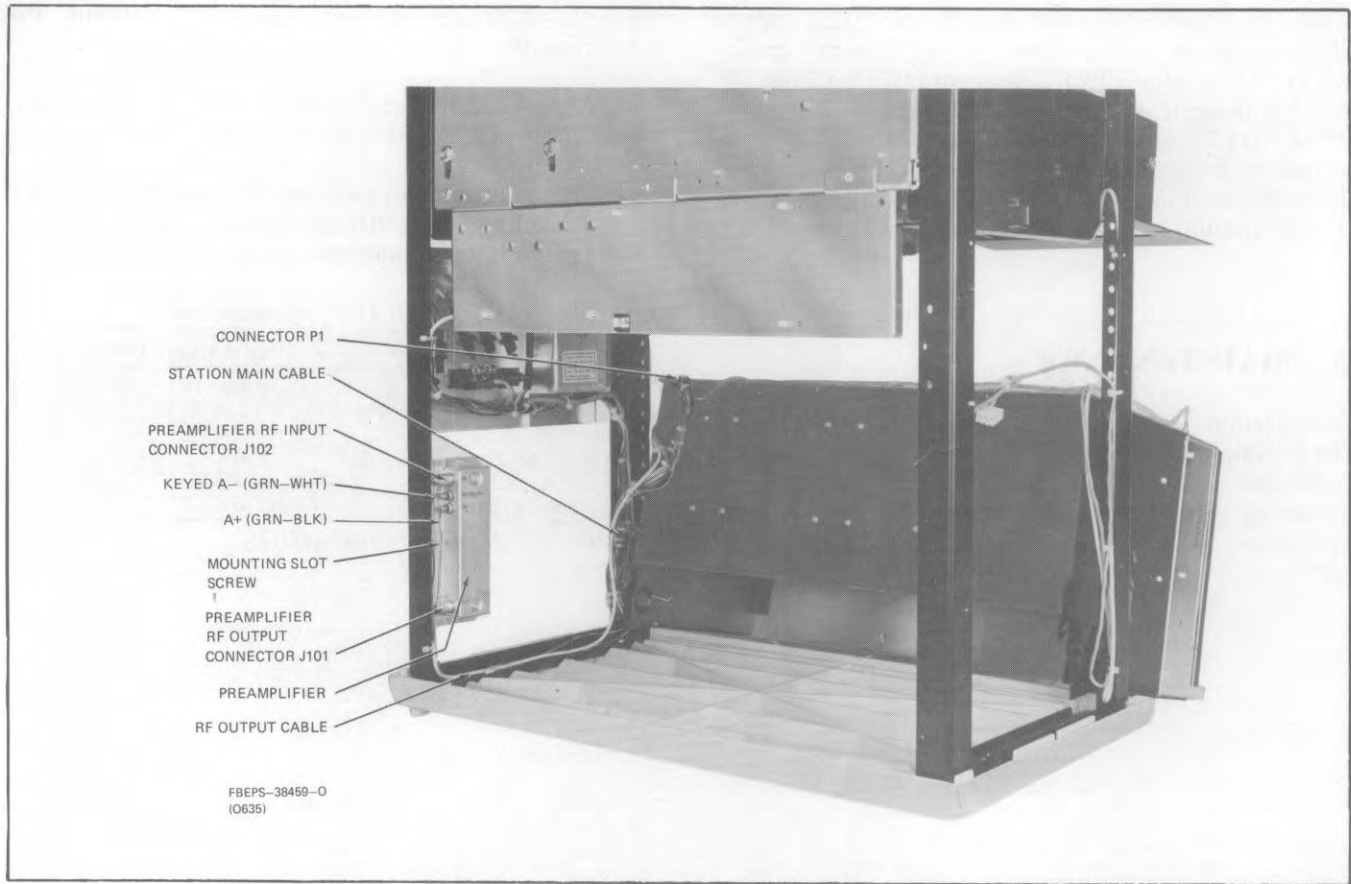

Figure 3. 1-Receiver Base Station

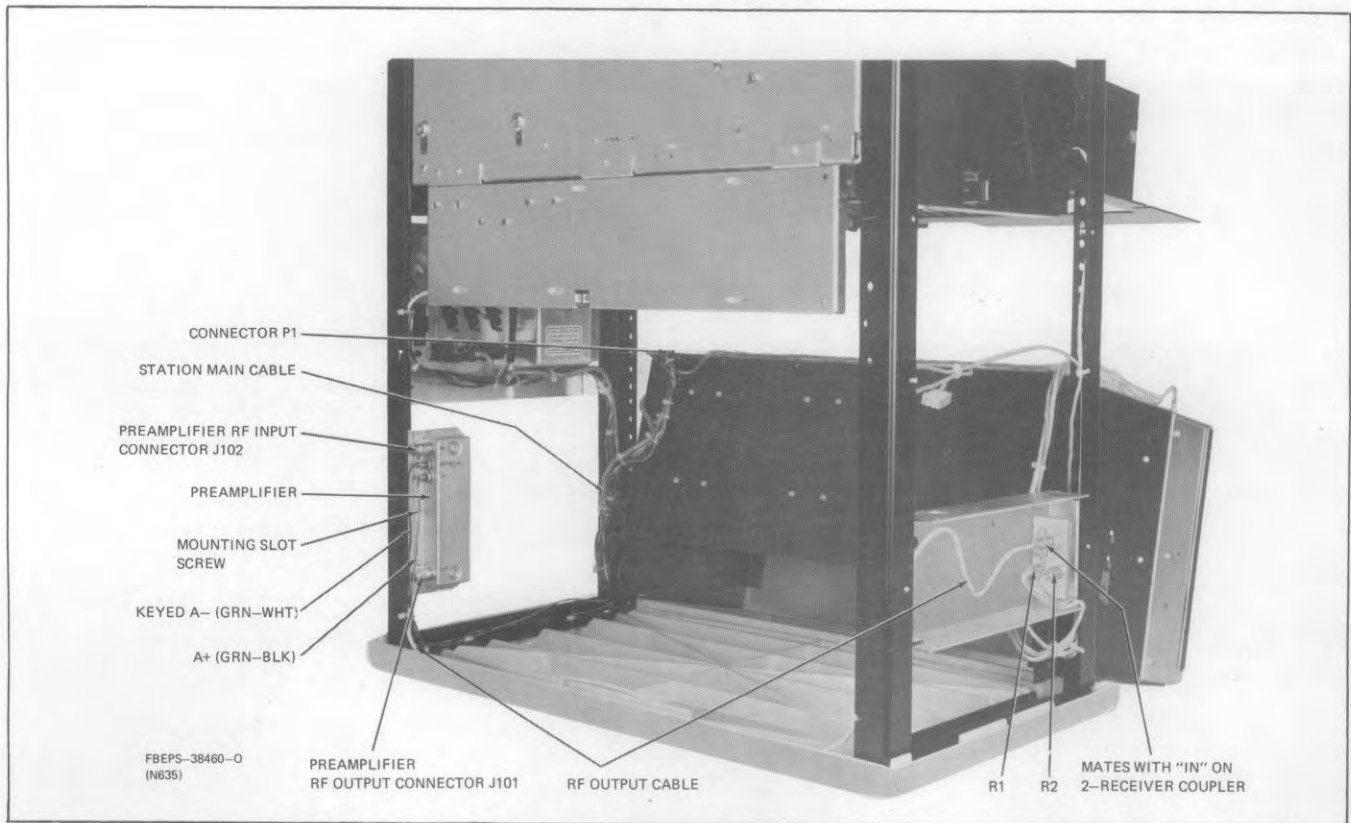

Figure 4. 2-Receiver Base Station

parts list

TLE5571A Preamplifier Board PL-8861-O

REFERENCE SYMBOL	MOTOROLA PART NO.	DESCRIPTION
C125	21-11014H21	capacitor, fixed: 6.8 pF ± 0.5 pF; 100 V
C126	21-11014H13	3.3 pF ± 0.25 pF; 100 V
C127	21-11014H23	8.2 pF ± 0.5 pF; 100 V
C128	21-11022G33	13 pF ± 5%; 50 V
C129	21-11014H13	3.3 pF ± 0.25 pF; 100 V
C130	21-11014H36	30 pF ± 5%; 100 V
C131	21-11022G42	33 pF ± 5%; 50 V
CR125	48-83510F04	diode, (see note) silicon
L125, 126	24-11030C05	coil, rf: coded (GRN)
L127	24-82723H28	choke; 290 nH
L129	24-83884G07	2.5 turns
Q125	48-869670	transistor, (see note) NPN; type M9870
Q126, 127	48-869643	PNP; type M9643
Q128	48-869642	NPN; type M9642
R125	6-11009A49	resistor, fixed: ± 5%; 1/4 W: 1k
R126	6-11009A69	6.8k
R127	6-11009A83	27k
R128	6-11009A27	120
R132	6-11009A13	33
R133	6-11009A25	100
R134	6-11009A73	10k
R135, 136	6-11009A65	4.7k
R138	6-11009A39	390

TRN9165A Preamplifier Hardware PL-8862-O

REFERENCE SYMBOL	MOTOROLA PART NO.	DESCRIPTION
C132, 133	21-861219	capacitor, fixed: 1000 uF + 100 - 0%
J101, 102	9-83663C01	connector, receptacle: female, single contact
P101	28-82875N01	connector, plug: male, single contact (phone)
P102	28-82331G01	male, single contact
mechanical parts		
1-80736D03		Assembly Cable; Receiver #1 includes: P101, 102
5-82050H04		EYELET; 2 used
30-83794C01		CABLE, coaxial (WHT); 33" used
1-80768D72		Assembly Bracket Phono & Feedthru; includes: J101, 102 and C132, 133
4-83755H01		WASHER, shoulder; 2 used
15-83220P01		HOUSING, preamplifier
2-131435		NUT, 4-40 x 1/4 x 3/32"; 2 used
3-134186		SCREW, tapping: 6-32 x 5/16"
3-134268		SCREW, tapping: 4-40 x 9/16"; 2 used
3-136891		SCREW, tapping: 4-24 x 1/4"; 8 used
4-691205		WASHER, insulator shoulder; 2 used
15-83221P01		COVER, preamplifier
42-10217A02		STRAP, tie: .091 x 3.62"; 5 used
29-84249N01		TERMINAL, receptacle; 2 used

note: For optimum performance, diodes, transistors, and integrated circuits must be ordered by Motorola part numbers.

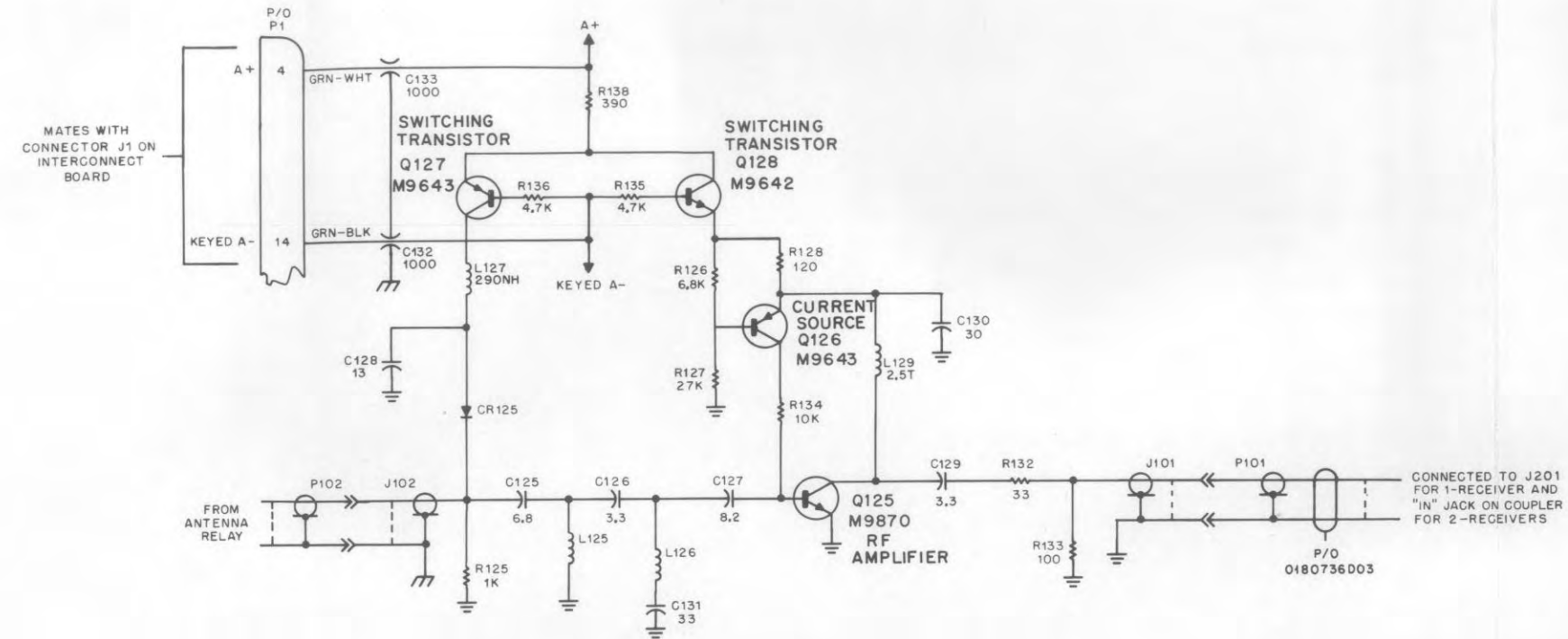

NOTES:
1. UNLESS OTHERWISE INDICATED, RESISTOR VALUES ARE IN OHMS; CAPACITORS VALUES ARE IN PICOFARADS.

CEPS-38396-0

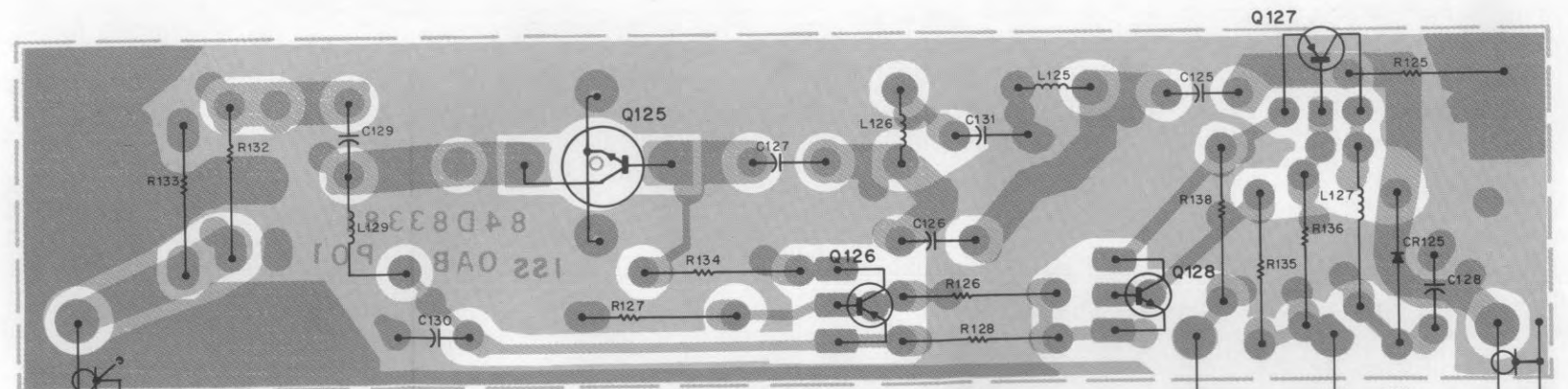

SHOWN FROM COMPONENT SIDE

COMPONENT SIDE = BD-CEPS-38393-0
SOLDER SIDE = BD-CEPS-38394-0
OL-CEPS-38395-0

TRANSISTOR BASE DETAILS (SHOWN FROM COMPONENT SIDE)

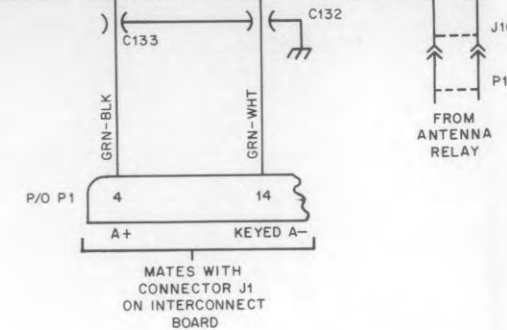
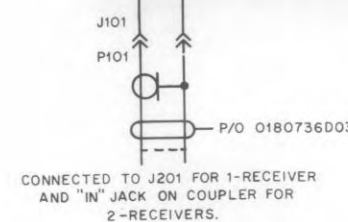
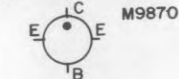

TLE2393A UHF RF Preamplifier
Schematic Diagram, Circuit Board Details
and Parts List
Motorola No. PEPS-38570-O
12/29/83-V&G

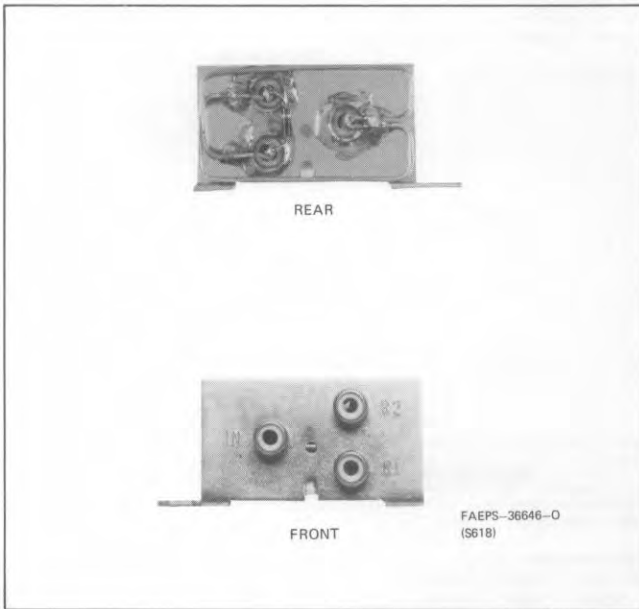

*Figure 1. 2-Receiver Coupler
 Front and Rear View*

1. ELECTRICAL DESCRIPTION

This unit allows two UHF receivers to operate from a single antenna source without interaction. It provides a correct impedance match between both receivers and the antenna source, and also provides isolation between the two receivers. Signal coupling and impedance matching is accomplished by utilizing two quarter-wave length coaxial transmission lines and a resistor.

2. PHYSICAL DESCRIPTION

The 2-receiver coupler, consisting of a bracket which mounts the electrical components and three cable connectors, is mounted on a chassis installed in the base station. When the coupler is used, the input to the

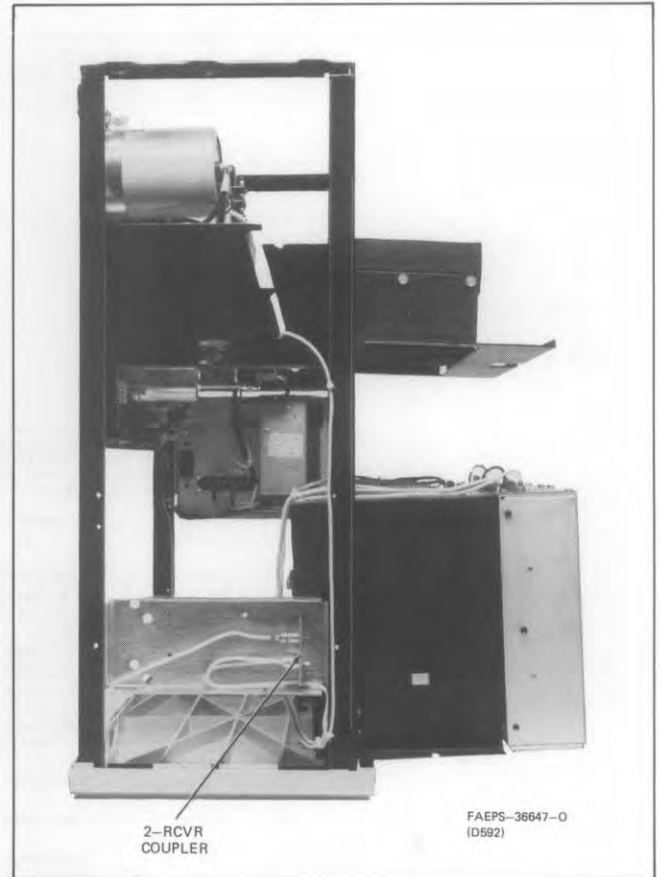

*Figure 2. 2-Receiver Coupler
 Installed Location*

receiver is disconnected and reconnected to the IN connector on the coupler. Coupler cable W1 connects between the R1 coupler connector and the receiver module input connector J201. Coupler cable W2 connects between the R2 coupler connector and the second receiver module input connector J301.

2-RECEIVER COUPLER

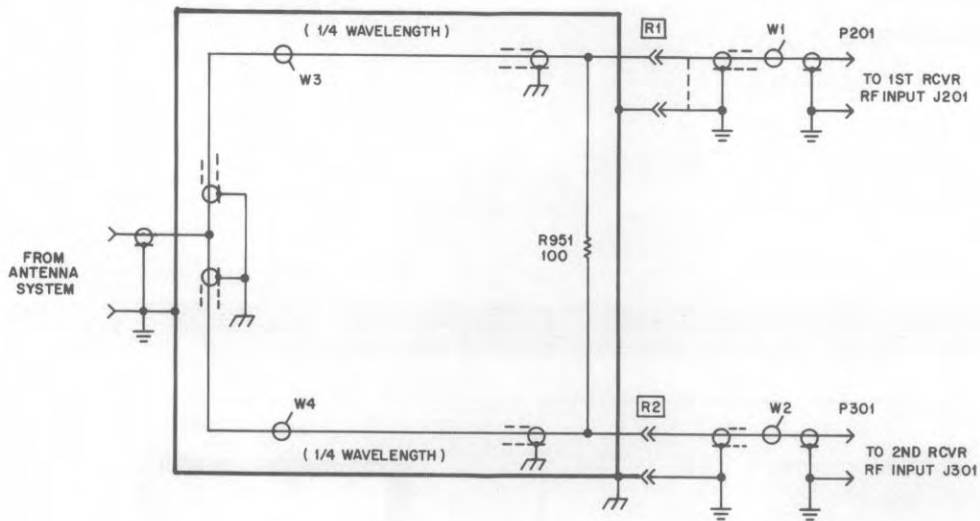

BEPS-36741-0

parts list

TLE5551A 2-Receiver Coupler

PL-8549-O

REFERENCE SYMBOL	MOTOROLA PART NO.	DESCRIPTION
R951	6-125A25	resistor, fixed: 100 ± 5%; 1/2 W
W1	1-80736D03 30-83794C01 28-82875N01 28-82331G01	cable, assembly: assembly, receiver-1; includes: CABLE, coaxial; 33" used CONNECTOR, plug; single contact CONNECTOR, plug (phono)
W2	1-80736D04 30-83794C01 28-82331G01 28-82875N01	assembly receiver-2; includes: CABLE, coaxial; 28" used CONNECTOR, plug; single contact CONNECTOR, plug (phono)
W3, 4	30-83233K01	cable, coaxial
mechanical parts		
	1-80768D66	ASSEMBLY, coupler; 2-receiver; includes: ref. items R951, W3, W4, and
	1-80775B68	ASSEMBLY, bracket and connector; includes:
	7-84131G01	BRACKET, splitter
	9-83663C01	RECEPTACLE, female; 3 used
	2-131435	NUT, 4-40 × 1/4 × 3/32"; 2 used
	3-134186	SCREW, tapping; 6-32 × 5/16"; 2 used
	3-82227A03	SCREW, machine; 4-40 × 5/16"; 2 used
	7-83020N01	BRACKET, coupler
	42-10217A02	STRAP, tie; 6 used
	42-82143C09	CLIP, cable; 2 used



MOTOROLA INC.

Communications
Sector

UHF DUPLEXER

MODELS T4084A, 85A, 5002A
406-520 MHz

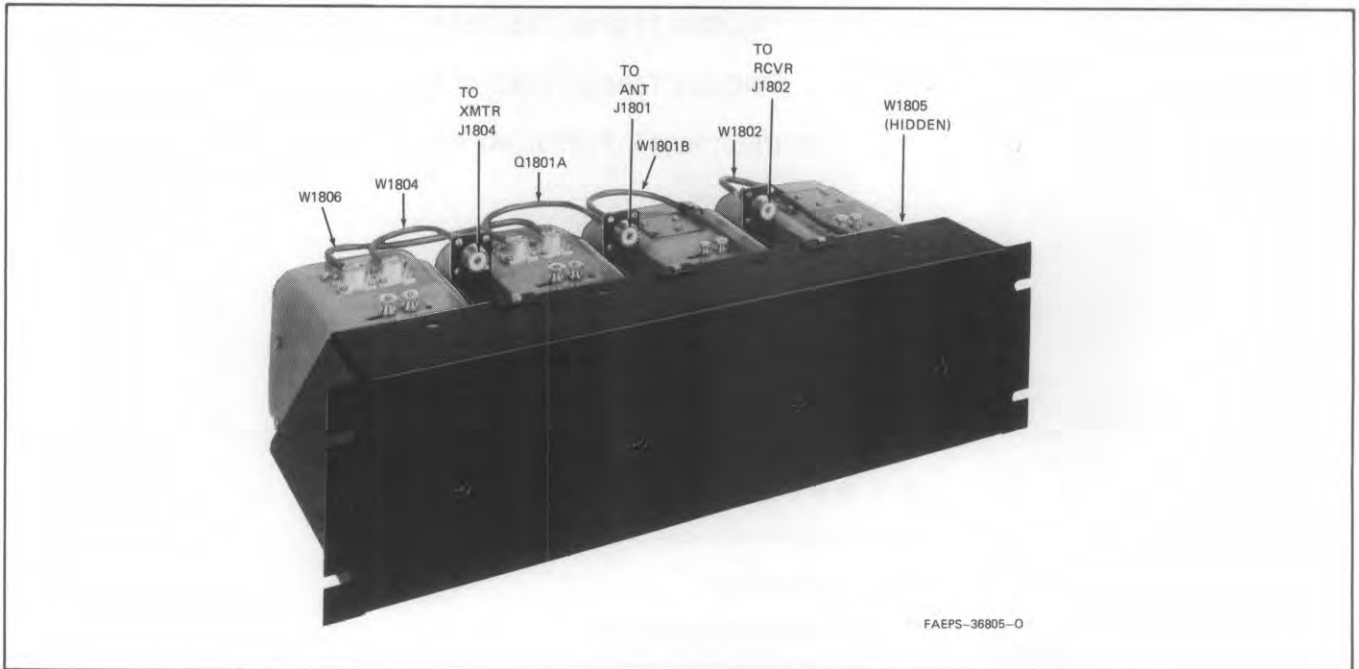

Figure 1. Typical 4-Cavity Duplexer

1. INTRODUCTION

These duplexers are for use with Motorola FM two-way radio communications equipment operating in the 406-520 MHz frequency range. The duplexers are 1/4-wave cavity resonators, which are temperature compensated and are tuned with an adjustable center conductor. The duplexers contain loops or probes terminated in low profile receptacle connectors with Teflon™ insulation. Tables 1 and 2 provide the performance specifications of each model duplexer. Figure 2 provides a model breakdown of these units.

These units may be used in the antenna circuit of a base or repeater station to eliminate or minimize receiver desensitization or intermodulation due to strong local signals. Similarly, they may be used to reduce transmitter noise or intermodulation products.

Teflon is a registered trademark of DuPont

Table 1. Model T4084A Performance Specifications

Operating Frequency	406-470 MHz
Transmitter or Receiver Insertion Loss:	
406-430 MHz	0.8 dB
430-470 MHz	0.7 dB
RCVR Isolation at Transmit Frequency	50 dB
XMTR Noise Suppression at Receive Frequency	50 dB
Transmitter-Receiver Isolation	45 dB
Frequency Separation (Min.)	5 MHz
VSWR Maximum	2:1
Maximum Power Input	250 W
Temperature Range	-30°C to +60°C
Size	19" W × 5-1/2" H × 8-1/2" D
Termination	UHF Female

SPECIFICATIONS SUBJECT TO CHANGE WITHOUT NOTICE

DUPLEXER

MODEL BREAKDOWN CHART

FOR

PASS-REJECT DUPLEXERS

406-520 MHZ

MODEL T4084A (TLE2351A); T—R GTE 5 MHZ

MODEL T4085A (TLE2363A); T—R GTE 3 MHZ

MODEL T5002A (TLE2383A); 2 MHZ LTE T—R LT 3 MHZ

ITEM	DESCRIPTION
TLE2351A	2-CAVITY DUPLEXER (406-470 MHZ)
TLE2363A	4-CAVITY DUPLEXER (406-520 MHZ)
TLE2383A	4-CAVITY DUPLEXER (406-470 MHZ)

CODE:

T—R = TRANSMIT—RECEIVE = FREQUENCY SEPARATION

LT = LESS THAN

LTE = LESS THAN OR EQUAL TO

GT = GREATER THAN

GTE = GREATER THAN OR EQUAL TO

● = ONE ITEM SUPPLIED

2 = INDICATES QUANTITY SUPPLIED

★ = ALTERNATIVE (ONE SUPPLIED) FREQUENCY DEPENDENT ITEM

KIT	DESCRIPTION
★ ★ ★	TKN8930A DUPLEXER ANTENNA CABLE (406-430 MHZ)
★ ★ ★	TKN8931A DUPLEXER ANTENNA CABLE (430-470 MHZ)
★	TKN8932A DUPLEXER ANTENNA CABLE (470-520 MHZ)
● ●	TKN8933A 4-CAVITY DUPLEXER TRANSMITTER CABLE
● ●	TKN8934A 4-CAVITY DUPLEXER RECEIVER CABLE
●	TKN8935A 2-CAVITY DUPLEXER TRANSMITTER CABLE
●	TKN8936A 2-CAVITY DUPLEXER RECEIVER CABLE
★ ★	TKN8962A 4-CAVITY DUPLEXER INTERCONNECT CABLES (406-430 MHZ)
★ ★	TKN8963A 4-CAVITY DUPLEXER INTERCONNECT CABLES (430-470 MHZ)
★	TKN8964A 4-CAVITY DUPLEXER INTERCONNECT CABLES (470-520 MHZ)
●	TRN5885A 2-CAVITY DUPLEXER MOUNTING HARDWARE
● 2 2	TRN8037A COUPLING PROBES
● ●	TRN8038A 4-CAVITY DUPLEXER MOUNTING HARDWARE
● 2	TRN8040A COUPLING LOOPS
2 4 4	TRN8041A CAVITY (406-520 MHZ)
2	TRN8124A COUPLING LOOPS (2 MHZ LTE T—R LT 3 MHZ)

EPS-37322-0

Figure 2. Duplexer Model Breakdown Chart

Table 2. Models T4085A & T5002A

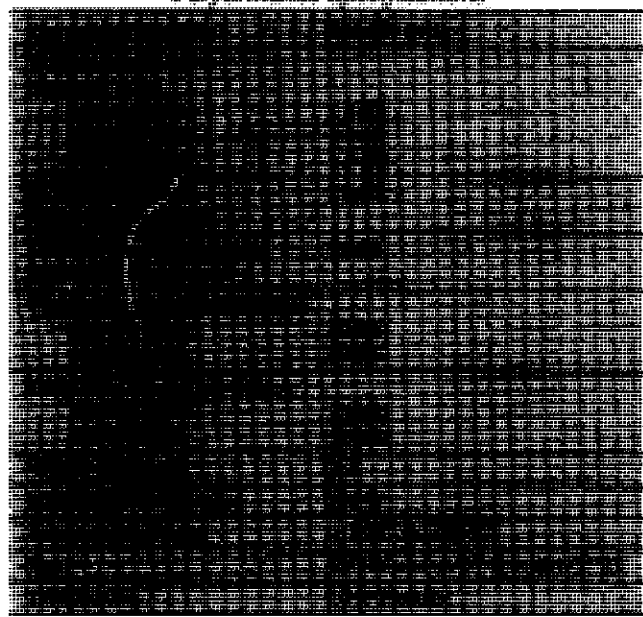

SPECIFICATIONS SUBJECT TO CHANGE WITHOUT NOTICE

2. FIELD INSTALLATION

Step 1. Carefully unpack the unit and check for concealed damage.

Step 2. The units are designed to mount on any standard 19-inch wide rack. Select position in rack for best location of unit, i.e., closest proximity to associated equipment inputs and outputs.

Step 3. Mount the unit in place in rack with appropriate mounting hardware. The hardware supplied is

intended for use with Motorola cabinetry and equipment racks.

Step 4. Connect the duplexer to the transmitter and receiver. Refer to Figure 3 (for 2-cavity hook-up), and Figure 4 (for 4-cavity, hook-up).

Step 5. The duplexer must be connected to the transmitter and receiver with appropriate lengths of 50-ohm coaxial cable (customer supplied) to fit the individual installation.

IMPORTANT

All duplexers are factory set and **SHOULD NOT** be "fine-tuned" into the antenna systems, since isolation changes significantly with any readjustment of the center tuning shaft. Station and duplexer performance will remain within specification without duplexer readjustment, if the antenna VSWR is **LTE** 2:1. Antenna VSWR can be measured by inserting a UHF-rated, in-line wattmeter (capable of withstanding at least 120 watts) between the duplexer and the antenna, via J1801. The ratio of the forward to reverse power should be **GTE** 9. If the antenna VSWR exceeds 2:1, the antenna system must be corrected. If the duplexers must be re-tuned, due to station frequency re-assignment, follow the Recommended Tuning Procedure paragraphs provided at the end of this section.

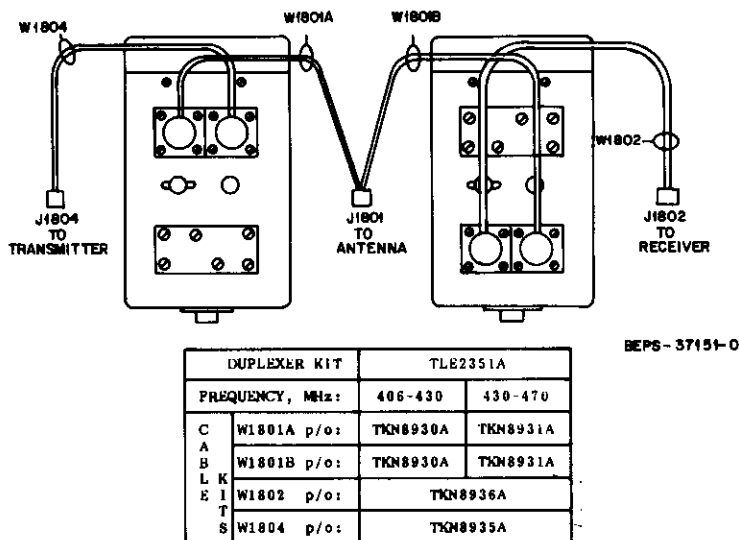
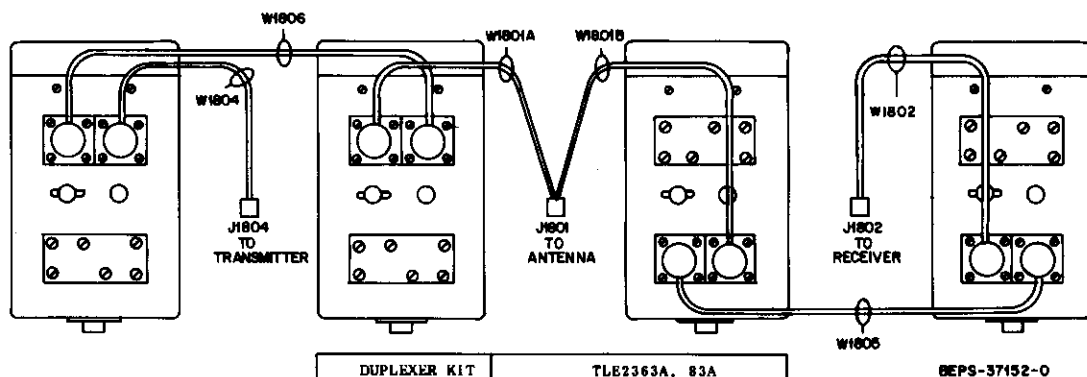

Figure 3. 2-Cavity Duplexer Cabling Detail



DUPLExER KIT		TLB2363A, 83A		
FREQUENCY, MHz:		406-430	430-470	470-520
C A B L E K I T S	W1801A p/o:	TKN8930A	TKN8931A	TKN8932A
	W1801B p/o:	TKN8930A	TKN8931A	TKN8932A
	W1802 p/o:	TKN8934A		
	W1804 p/o:	TKN8933A		
	W1805 p/o:	TKN8962A	TKN8963A	TKN8964A
	W1806 p/o:	TKN8962A	TKN8963A	TKN8964A

Figure 4. 4-Cavity Duplexer Cabling Detail

3. THEORY OF OPERATION

Each resonant cavity, technically a reentrant quarter-wave resonator, is a very high Q (low loss) tunable tank circuit. The dimensions of each resonator are designed for minimum loss. The cavities are tuned to the required pass frequency by an adjustment which changes the length of the center conductor. Lower frequencies have more of the center conductor inside the cavity, higher frequencies have correspondingly less. INVAR™, a material with a very low temperature coefficient of expansion (used for the tuning shaft), and special bimetallic washers are used to provide temperature compensation to minimize detuning due to ambient temperature changes.

Each resonant cavity is fitted with a specially designed pair of coupling elements (loops or probes). These loops and probes efficiently convert energy from the 50-ohm coaxial cable to the correct mode inside the resonant structure. When the cavity is not tuned to resonance, most of the energy is reflected. Only a small portion is able to excite the correct mode and reach the output element.

Pass-reject duplexers have their input and output coupling loops placed very close to each other, to take advantage of mutual inductive coupling. That is, small amount of energy is always being transferred between coupling loops because of their proximity. At one frequency, the energy transferred by mutual coupling cancels the energy transferred across by the resonant mode within the cavity. Thus, at one frequency, there is a reject notch in addition to the normal selectivity of the cavity. When coupling loops are used, the notch occurs above the pass frequency. When coupling probes are

used, the notch occurs below the pass frequency. The notch frequency is adjusted by changing the physical spacing between the coupling elements.

Cavities are used on each side of a duplexer. Those cavities tuned to pass the lower frequency have coupling loops (Figure 5) tuned to notch out the higher frequency. Those cavities tuned to pass the higher frequency have coupling probes (Figure 6) tuned to notch out the lower frequency. Odd quarter-wave coupling is used between cavities to obtain minimum pass frequency bandwidth and minimum insertion loss.

4. INSTALLATION OF COUPLING ELEMENTS

Coupling loops and probes are factory-installed. If it becomes necessary to change the coupling elements, refer to Figures 5, 6, and the mechanical detail photographs at the end of this section. Then, use one of the following procedures.

4.1 NOTCH COUPLING LOOPS PROCEDURE (Models TRN9040A or TRN9124A)

Models T4084A, T4085A, and T5002A each employ notch coupling loops. They have a fixed insertion loss of 0.5 - 0.7 dB when correctly installed. Refer to Figure 5. The notch coupling loops can be installed without removing the cavity bottom cover assembly.

Step 1. Place the adjustable loop in the right-hand (cavity viewed from the outside, tuning screw up, facing connectors) position so that the extruded and tapped hole in the loop lines up with the adjusting slot in the cavity body assembly.

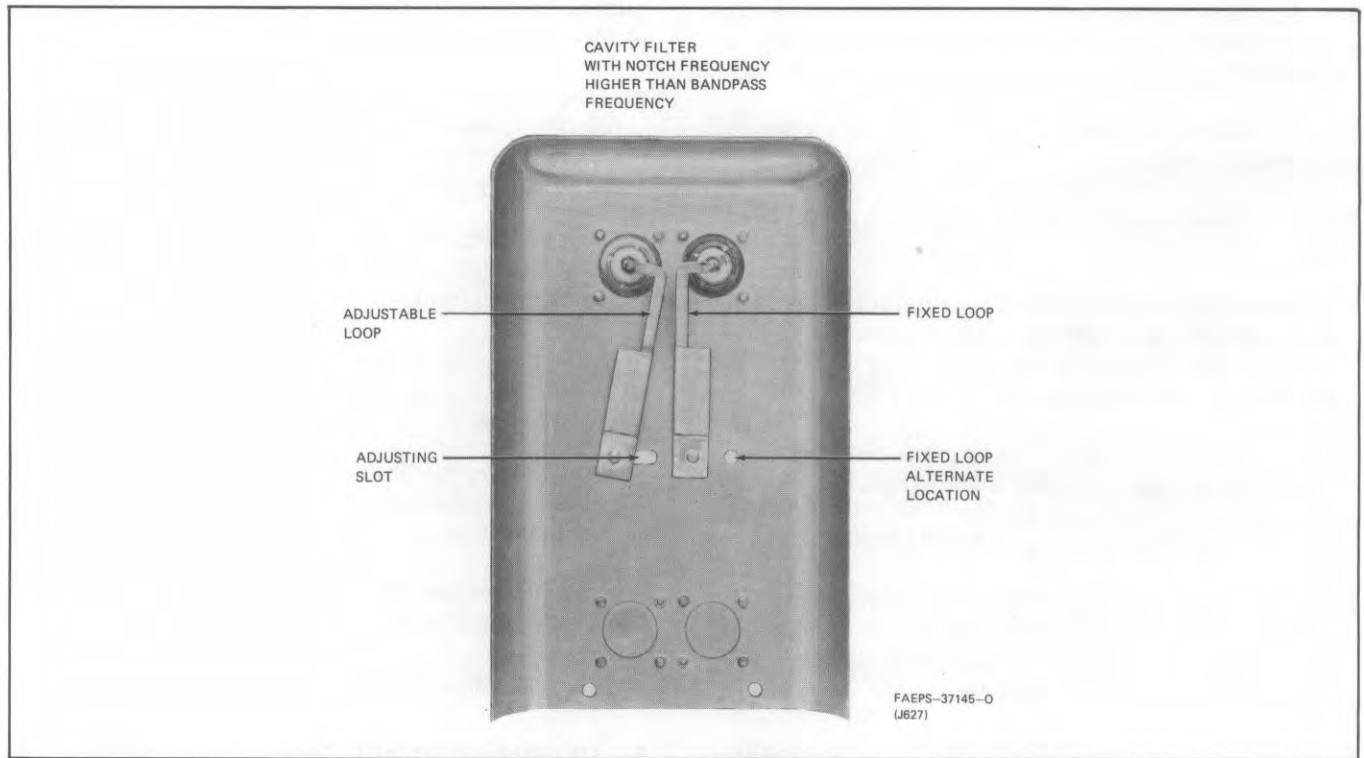

Figure 5. Notch Coupling Loops (Interior View)

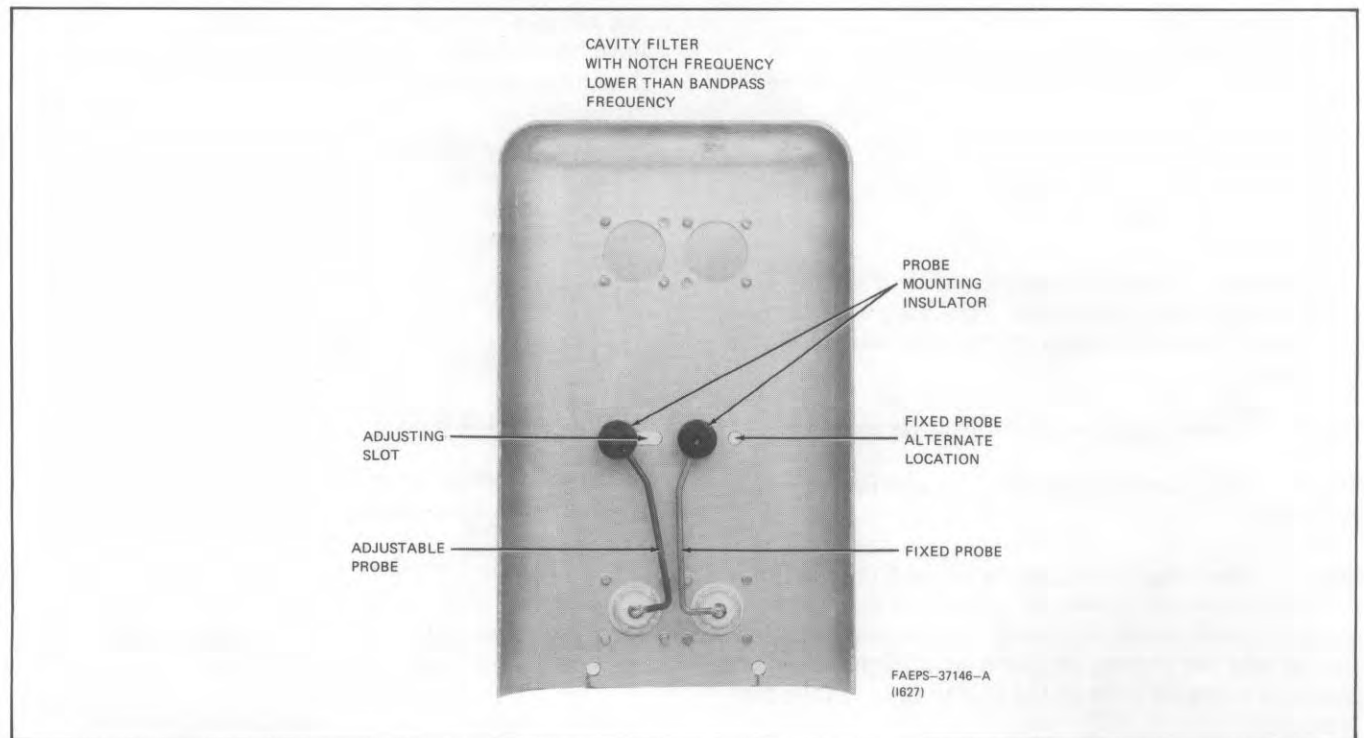

Figure 6. Notch Coupling Probes (Interior View)

Step 2. Secure the adjustable loop to the cavity body with a knurled machine screw provided, using a lockwasher and plastic washer under the screw head.

Step 3. Fasten the low profile connector to the cavity body with the self-tapping hardware provided.

Step 4. Determine the correct location for the fixed loop.

- If the required separation between the filter pass and reject frequencies is greater than or equal to 2 MHz and less than 3 MHz, use the fixed location closest to the adjusting slot, and loop kit Model TRN9124A.
- If the required separation between the filter pass and reject frequencies is greater than or equal to 3 MHz and less than 5 MHz, use the fixed location closest to the adjusting slot, and loop kit Model TRN9040A.
- If the required separation is greater than or equal to 5 MHz and less than 8 MHz, use the fixed location furthest (the alternate location) from the adjusting slot, and loop kit Model TRN9040A.

Step 5. Place the fixed loop in the left-hand position so that the extruded and tapped hole in the loop lines up with the desired fixed hole location in the cavity body.

Step 6. Secure the fixed loop to the cavity body with a knurled machine screw provided, using a lockwasher and plastic washer under the screw head.

Step 7. Fasten the low profile connector to the cavity body with the self-tapping hardware provided.

4.2 NOTCH COUPLING PROBES PROCEDURE (Model TRN9037A)

Models T4084A, T4085A, and T5002A each employ notch coupling probes. They have a fixed insertion loss of 0.5-0.7 dB when correctly installed. Refer to Figure 6.

Step 1. Remove the cavity bottom cover assembly.

Step 2. Place a mounting insulator on the adjustable probe.

Step 3. Insert the adjustable probe and the mounting insulator into the right-hand (cavity viewed from the outside, tuning screw up, facing connectors) loop position so that the copper, threaded stem of the mounting insulator extended through the adjusting slot in the cavity body.

Step 4. Secure the adjustable probe to the cavity body with a knurled nut provided, using a lock-washer and plastic washer under the nut.

Step 5. Fasten the low profile connector to the cavity body with the self-tapping hardware provided.

Step 6. Determine the correct location for the fixed probe.

- If the required separation between the filter pass and reject frequencies is greater than 2 MHz and less than or equal to 5 MHz, use the fixed location closest to the adjusting slot.
- If the required separation is greater than 5 MHz and less than 8 MHz, use the fixed location furthest (the alternate location) from the adjusting slot.

Step 7. Place the fixed probe in the left-hand position so that the mounting insulator stud extends through the desired fixed hole location in the cavity body.

Step 8. Secure the fixed probe to the cavity body with a knurled nut provided, using a lockwasher and plastic washer under the nut.

Step 9. Fasten the low profile connector to the cavity body with the self-tapping hardware provided.

Step 10. Replace the cavity bottom cover assembly.

5. RECOMMENDED TUNING PROCEDURE

All duplexers are tuned to the customer-specified frequencies prior to shipment from the factory. If system performance indicates that the duplexer is detuned, one of the following procedures may be used. Do not attempt to re-tune unless the following procedures have been both read, and it is certain that performance does not meet specifications.

The following tuning procedures assume that the entire duplexer is to be re-tuned. When left and right are used in the following procedures, this shall mean facing the tuning shaft end and with the connectors up.

5.1 METHOD 1

5.1.1 Recommended Test Equipment

- Motorola R-2001 or R-1201 Signal Generator.
- Tunable receiver or two Motorola receivers, one tuned to each of the frequencies to be duplexed.

5.1.2 Tuning Procedure

Step 1. Move sliding screws as far apart as possible on each cavity and then tighten the screws.

Step 2. Tune the signal generator and the receiver to the duplex receive frequency.

Step 3. Connect the signal generator to the antenna port and the receiver to the right-hand port.

Step 4. Tune the right-hand cavity(s) for minimum insertion loss by adjusting the tuning rod screw.

Step 5. Tune the signal generator and the receiver to the duplex transmit frequency.

Step 6. Connect the receiver to the left-hand port.

Step 7. Tune the left-hand cavity(s) for minimum insertion loss by adjusting the tuning rod screw.

Step 8. Connect the receiver to the right-hand port.

Step 9. Tune the right-hand cavity(s) for maximum attenuation by using the Tuning The Notch procedure paragraphs provided at the end of this section.

Step 10. Tune the signal generator and the receiver to the duplex receive frequency.

Step 11. Connect the receiver to the left-hand port.

Step 12. Tune the left-hand cavity(s) for maximum attenuation by using the Tuning The Notch procedure paragraphs provided at the end of this section.

5.2 METHOD 2

5.2.1 Recommended Test Equipment

- Mixer circuit constructed as shown in Figure 7.
- Motorola R-2001 or R1201 Signal Generator.
- I-F output from R1201 Series Signal Generator equal to the duplex frequency separation or a Motorola S1056 Portable Test Set with a crystal frequency equal to the duplex frequency separation.
- Motorola S1350 Wattmeter.
- Motorola T1013 RF Load Resistor.
- Isolated Tee connector (construct this by removing the Tee port center pin of a UHF Tee connector). This provides 30 to 40 dB of isolation between the shunt path and the direct path through the Tee to protect the receiver when the transmitter is keyed.
- Transmitter and receiver from the station to be duplexed.

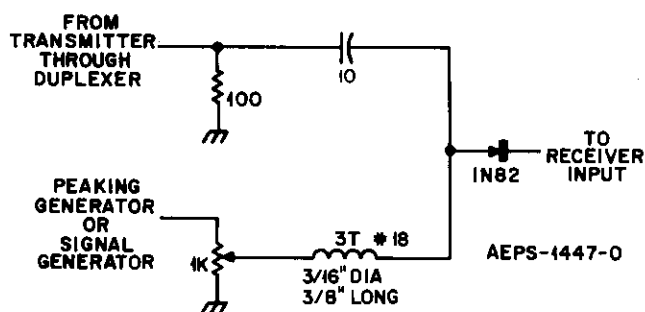

Figure 7. Mixer Circuit

5.2.2 Operation of the Mixer Circuit

Alignment of the duplexers can be simplified by using the mixer circuit shown in Figure 7. The mixer receives inputs from the transmitter and a low frequency source. The outputs from the mixer are frequencies above and below the transmitter frequency at separations equal to the output of the low frequency generator.

The receiver will respond to one of the mixer products and thus can be used indirectly to detect the transmitter frequency.

5.2.3 Tuning Procedure

Step 1. Move sliding screws as far apart as possible on each cavity and then tighten the screws.

Step 2. Connect the equipment as shown in Figure 8.

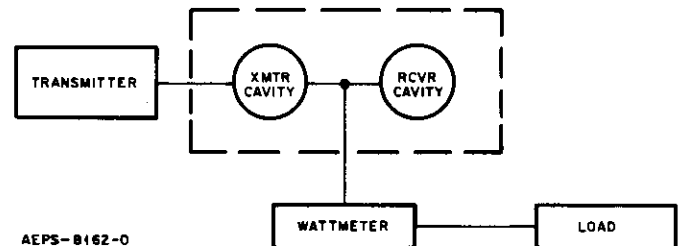

Figure 8. Method 2 Transmitter Branch Pass Test Set-Up

Step 3. Tune the left-hand cavity(s) for a maximum power reading on the wattmeter by adjusting the tuning rod screw.

Step 4. Connect the equipment as shown in Figure 9.

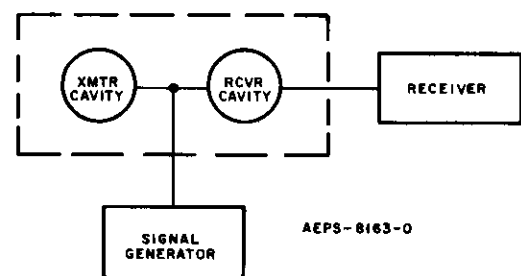

Figure 9. Method 2 Receiver Branch Pass Test Set-Up

Step 5. Tune the signal generator to the receive frequency.

Step 6. Tune the right-hand cavity(s) for a minimum insertion loss (maximum signal at the receiver) by adjusting the tuning rod screw.

Step 7. Connect the equipment as shown in Figure 10.

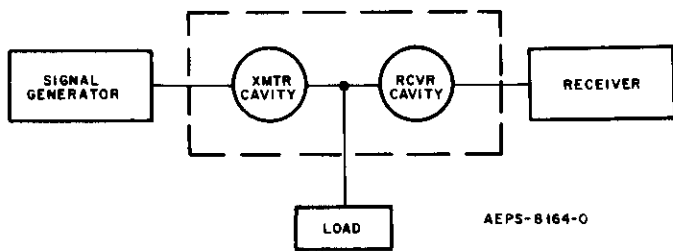

Figure 10. Method 2 Transmitter Branch Reject Test Set-Up

Step 8. Tune the left-hand cavity(s) for maximum attenuation by using the procedure Tuning The Notch.

Step 9. Connect the equipment as shown in Figure 11.

Step 10. Set the local oscillator source to the exact duplex frequency separation.

Step 11. Tune the right-hand cavity(s) for maximum attenuation by using the Tuning The Notch procedure.

Step 12. Connect the duplexer to the transmitter, receiver and antenna with 50-ohm coaxial cable. Adjust the transmitter final amplifier for rated power into the duplexer.

5.3 TUNING THE NOTCH PROCEDURE

5.3.1 If the Notch (Reject) Frequency is Below the Pass Frequency (Probe Cavities):

Step 1. Loosen the knurled nut slightly.

Step 2. Slide nut until minimum signal is received and then re-tighten the nut. The probe may shift slightly when it is tightened. Therefore, it is advisable to have the nut tight enough so that it can be barely moved while adjusting it.

Step 3. Repeat for any other probe cavity.

5.3.2 If the Notch (Reject) Frequency is Above the Pass Frequency:

Step 1. Loosen the knurled screw slightly.

Step 2. Slide screw until minimum signal is received and then re-tighten the screw. The loop may shift slightly when it is tightened. Therefore, it is advisable to have the screw tight enough so that it can be barely moved while adjusting it.

Step 3. Repeat for any other loop cavities.

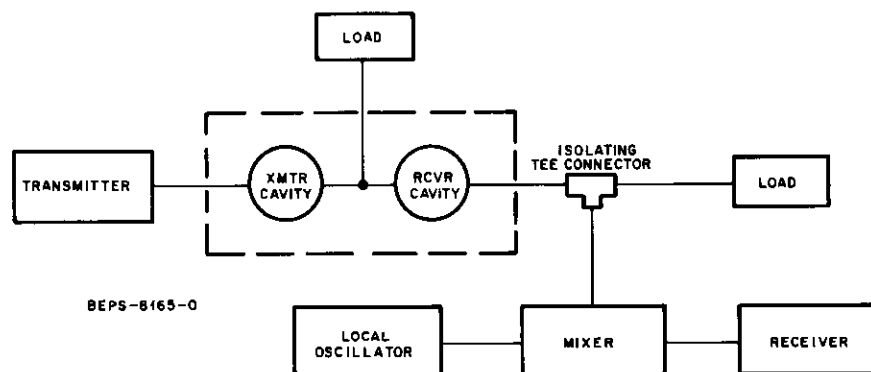

Figure 11. Method 2 Receiver Branch Reject Test Set-Up

parts list

TKN8930A Duplexer Antenna Cable (406-430 MHz) PL-8627-O

REFERENCE SYMBOL	MOTOROLA PART NO.	DESCRIPTION
J1801	9-82442E05	connector, receptacle: female, single contact; UHF-type
W1801A W1801B 18 19 21	30-83278B01 30-83278B01 2-131435 7-83454N01 15-83147P01	cable: coaxial RG142B/U; 9.125" used coaxial RG142B/U; 13" used NUT, 4-40 x 1/4 x 3/32"; 4 used BRACKET, connector HOOD
mechanical parts		
3-1937 4-114583	SCREW, machine: 4-40 x 5/16"; 4 used LOCKWASHER #4 split; 4 used	

TKN8931A Duplexer Antenna Cable (430-470 MHz) PL-8628-O

REFERENCE SYMBOL	MOTOROLA PART NO.	DESCRIPTION
J1801	9-82442E05	connector, receptacle: female, single contact; UHF-type
W1801A W1801B 18 19 21	30-83278B01 30-83278B01 2-131435 7-83454N01 15-83147P01	cable: coaxial RG142B/U; 8.375" used coaxial RG142B/U; 11.875" used NUT, 4-40 x 1/4 x 3/32"; 4 used BRACKET, connector HOOD
mechanical parts		
3-1937 4-114583	SCREW, machine: 4-40 x 5/16"; 4 used LOCKWASHER #4 split; 4 used	

TKN8932A Duplexer Antenna Cable (470-520 MHz) PL-8629-O

REFERENCE SYMBOL	MOTOROLA PART NO.	DESCRIPTION
J1801	9-82442E05	connector, receptacle: female, single contact; UHF-type
W1801A W1801B 18 19 21	30-83278B01 30-83278B01 2-131435 7-83454N01 15-83147P01	cable: coaxial RG142B/U; 7.25" used coaxial RG142B/U; 10.625" used NUT, 4-40 x 1/4 x 3/32"; 4 used BRACKET, connector HOOD
mechanical parts		
3-1937 4-114583	SCREW, machine: 4-40 x 5/16"; 4 used LOCKWASHER #4 split; 4 used	

TKN8933A 4-Cavity Duplexer Transmitter Cable PL-8630-O

REFERENCE SYMBOL	MOTOROLA PART NO.	DESCRIPTION
J1804	9-82442E02	connector, receptacle: female, single contact; UHF-type
W1804 18 19 20	30-83278B01 2-131435 7-83454N01 15-483599	cable: coaxial RG142B/U; 6.75" used NUT, 4-40 x 1/2 x 3/32"; 4 used BRACKET, connector HOOD
mechanical parts		
3-1937 4-114583	SCREW, machine: 4-40 x 5/16"; 4 used LOCKWASHER #4 split; 8 used	

TKN8935A 2-Cavity Duplexer Transmitter Cable PL-8631-O

REFERENCE SYMBOL	MOTOROLA PART NO.	DESCRIPTION
J1804	9-82442E05	connector, receptacle: female, single contact; UHF-type
W1804 18 19 20	30-83278B01 2-131435 7-83454N01 14-483599	cable: coaxial, RG142B/U; 7.75" used NUT, 4-40 x 1/2 x 3/32"; 4 used BRACKET, connector HOOD
mechanical parts		
3-1937 4-114583	SCREW, machine: 4-40 x 5/16"; 4 used LOCKWASHER #4 split; 4 used	

TKN8962A 4-Cavity Duplexer Interconnect Cable (406-430 MHz) PL-8633-O

REFERENCE SYMBOL	MOTOROLA PART NO.	DESCRIPTION
W1805 W1806	30-83278B01 30-83278B01	cable: coaxial, RG142B/U; 10.125" used coaxial, RG142B/U; 11.25" used

TKN8934A 4-Cavity Duplexer Receiver Cable PL-8632-O

REFERENCE SYMBOL	MOTOROLA PART NO.	DESCRIPTION
J1802	9-82442E02	connector, receptacle: female, single contact; UHF-type
W1802 18 19 20	30-83278B01 2-131435 7-83454N01 15-483599	cable: coaxial, RG142B/U; 9.75" used NUT, 4-40 x 1/2 x 3/32"; 4 used BRACKET, connector HOOD
mechanical parts		
3-1937 4-114583	SCREW, machine: 4-40 x 5/16"; 4 used LOCKWASHER #4 split; 4 used	

TKN8963A 4-Cavity Duplexer Interconnect Cable (430-470 MHz) PL-8634-O

REFERENCE SYMBOL	MOTOROLA PART NO.	DESCRIPTION
W1805 W1806	30-83278B01 30-83278B01	cable: coaxial, RG142B/U; 9.25" used coaxial, RG142B/U; 10.5" used

TKN8964A 4-Cavity Duplexer Interconnect Cable (470-520 MHz) PL-8635-O

REFERENCE SYMBOL	MOTOROLA PART NO.	DESCRIPTION
W1805 W1806	30-83278B01 30-83278B01	cable: coaxial, RG142B/U; 8.625" used coaxial, RG142B/U; 10.125" used

TRN9037A Coupling Probes PL-8636-O

ITEM	MOTOROLA PART NO.	DESCRIPTION
12	1-80778D87 4-84999C01 9-84000D01 14-84001D01 15-84998C01 24-84238A05 42-82388C01	Assembly Right Probe; includes: WASHER, spacer JACK, reversed end INSERT, connector HOUSING, connector RING, retainer
13	1-80778D88 4-84999C01 9-84000D01 14-84001D01 15-84998C01 24-84238A05 42-82388C01	Assembly Left Probe; includes: WASHER, spacer JACK, reversed end INSERT, connector HOUSING, connector RING, retainer

TRN9038A 4-Cavity Duplexer Mounting Hardware PL-8637-O

ITEM	MOTOROLA PART NO.	DESCRIPTION
1	3-3398	SCREW, tapping: 6-32 x 3/8"; 35 used
5	3-400356	SCREW, tapping: 4-24 x 1/4"; 56 used
6	15-84002D01	COVER, connector; 8 used
7	3-82245E04	SCREW, knurled; 4 used
8	2-84447A01	NUT, knurled; 4 used
9	15-84993C04	COVER, housing; 4 used
10	64-84253A03	PLATE, cover; 4 used
16	27-82934N01	CHASSIS, duplexer
17	42-82143C01	CLAMP, cable: 3/16" (BLK); 2 used
mechanical parts		
3-83498N08 4-7569	SCREW, tapping: M6 x 1 x 10mm; 4 used WASHER, flat: 0.145 x 0.312 x .027"; 2 used	
4-9746 4-9777 4-10059B37 4-82418B01	LOCKWASHER #8 split; 8 used WASHER, nylon (BLK); 2 used WASHER, insulator; 8 used	
14-84240A01 33-84332B01	INSULATOR, probe mounting; 4 used NAMEPLATE; 4 used	

TRN9040A Coupling Loops (see note) PL-8638-O

ITEM	MOTOROLA PART NO.	DESCRIPTION
3	1-80778D85 4-84999C01 9-84000D01 14-84001D01 15-84998C01 24-84238A01 42-82388C01	Assembly Loop Right; includes: WASHER, spacer JACK, reversed end INSERT, connector HOUSING, connector LOOP, cavity RING, retainer
11	1-80778D86 4-84999C01 9-84000D01 14-84001D01 15-84998C01 24-84238A03 42-82388C01	Assembly Loop Left; includes: WASHER, spacer JACK, reversed end INSERT, connector HOUSING, connector LOOP, cavity RING, retainer

Note: Used for; T—R Frequency Separation; GTE 3 MHz

TRN9041A Cavity (406-520 MHz) PL-8639-O

ITEM	MOTOROLA PART NO.	DESCRIPTION
2	1-80778D95 1-80778D89 41-84246A01 47-84348A02 15-84244A02 43-82155P01 47-82154P01	Assembly Can Hardware; includes: Assembly Tube miscellaneous; includes: SPRING, contact TUBE HOUSING, cavity BUSHING SHAFT, tuning
mechanical parts		
3-7110 4-84250A01 4-84251A01 4-84994C03 41-82152P01 42-824977 47-84255A01	SCREW, set: 8-32 x 3/16"; 3 used WASHER, flat: 0.39 x 0.75 x 0.03; 2 used WASHER, flat: 0.39 x 0.75 x 0.03 copper WASHER SPRING, coil cavity RING, arm retainer PLUNGER	

TKN8936A 2-Cavity Duplexer Receiver Cable PL-8640-O

REFERENCE SYMBOL	MOTOROLA PART NO.	DESCRIPTION
J1802	9-82442E05	connector, receptacle: female, single contact; UHF-type
W1802 18 19 20	30-83278B01 2-131434 7-83454N01 15-483599	cable: coaxial, RG142B/U; 10.75" used NUT, 4-40 x 1/4 x 3/32"; 4 used BRACKET, connector HOOD
mechanical parts		
3-1937 4-114583	SCREW, machine: 4-40 x 5/16"; 4 used LOCKWASHER #4 split; 4 used	

TRN5885A 2-Cavity Duplexer Mounting Hardware PL-8641-O

ITEM	MOTOROLA PART NO.	DESCRIPTION
1	3-3389	SCREW, tapping: 6-20 x 3/8"; 19 used
5	3-400356	SCREW, tapping: 4-24 x 1/4"; 28 used
6	15-84002D01	COVER, connector; 6 used
7	3-82245E04	SCREW, knurled; 12 used
8	2-84447A01	NUT, knurled; 2 used
9	15-84993C04	COVER, housing; 2 used
10	64-84253A03	PLATE, cover
16	27-82934N01	CHASSIS, duplexer
17	42-82143C01	CLAMP, cable: 3/16" (BLK); 2 used
mechanical parts		
3-83498N08 4-7569	SCREW, tapping: M6 x 1 x 10mm; 4 used WASHER, flat: 0.145 x 0.312 x .027"; 2 used	
4-9746 4-9777 4-10059B37 4-82418B01 14-84240A01	LOCKWASHER #8 split; 4 used LOCKWASHER #4 split; 28 used WASHER, nylon (BLK); 4 used WASHER, insulator; 4 used INSULATOR, probe mounting; 2 used	

TRN9124A Coupling Loops (see note) PL-8667-O

ITEM	MOTOROLA PART NO.	DESCRIPTION
3	1-80778D85 4-84999C01 9-84000D01 14-84001D01 15-84998C01 24-84238A01 42-82388C01	Assembly Loop Right; includes: WASHER, spacer JACK, reversed end INSERT, connector HOUSING, connector LOOP, cavity RING, retainer
11	1-80780D30 4-84999C01 9-84000D01 14-84001D01 15-84998C01 24-84238A05 42-82388C01	Assembly Loop Left; includes: WASHER, spacer JACK, reversed end INSERT, connector HOUSING, connector LOOP, cavity RING, retainer

Note: Used for; 2 MHz GTE T—R Frequency Separation LT 3 MHz.

UHF DUPLEXER

MODELS T4084A, 85A, 5002A
406-520 MHz

PASS-REJECT DUPLEXER
(2 - CAVITY COMBINED LOOP & PROBE)

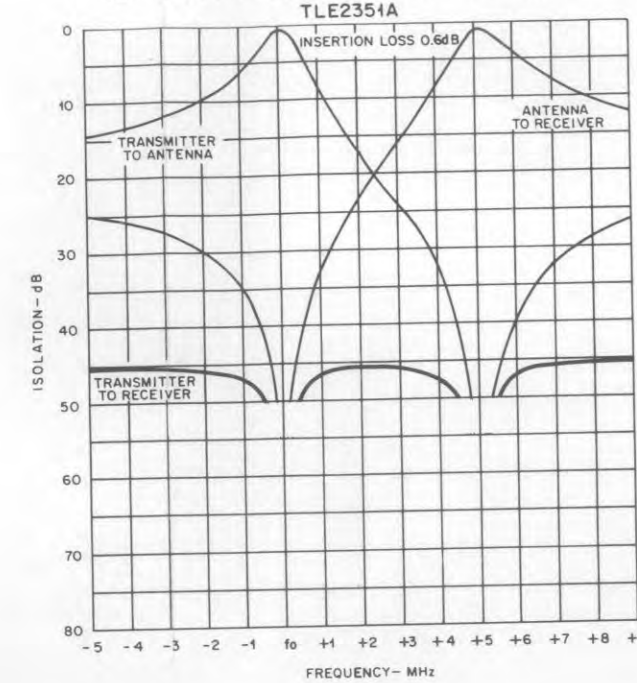

PASS-REJECT DUPLEXER
(4 - CAVITY COMBINED LOOP & PROBE)

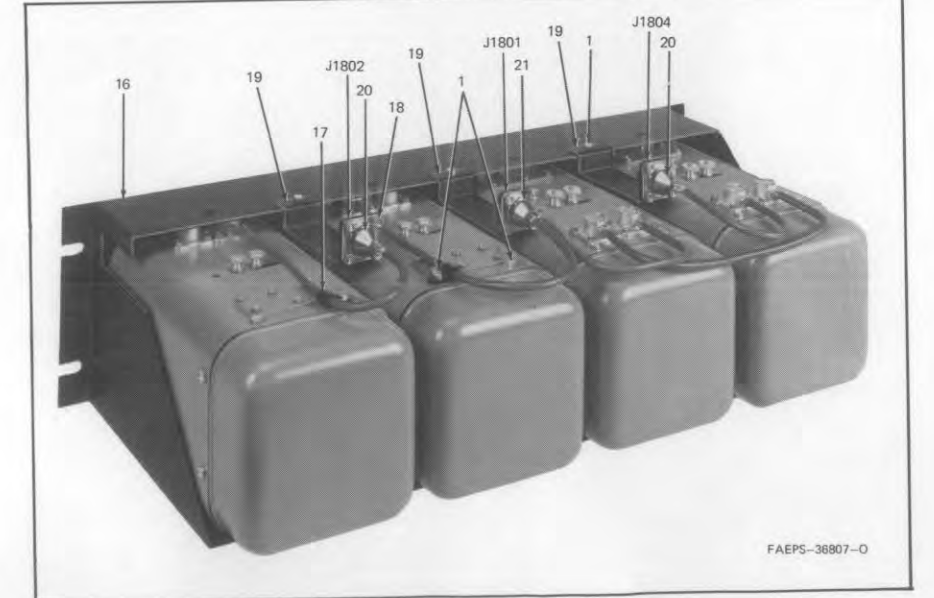
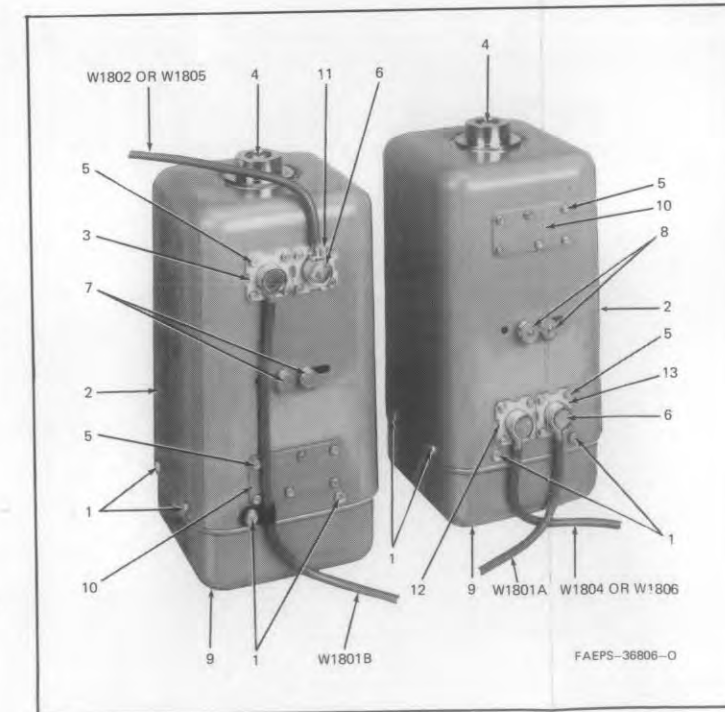
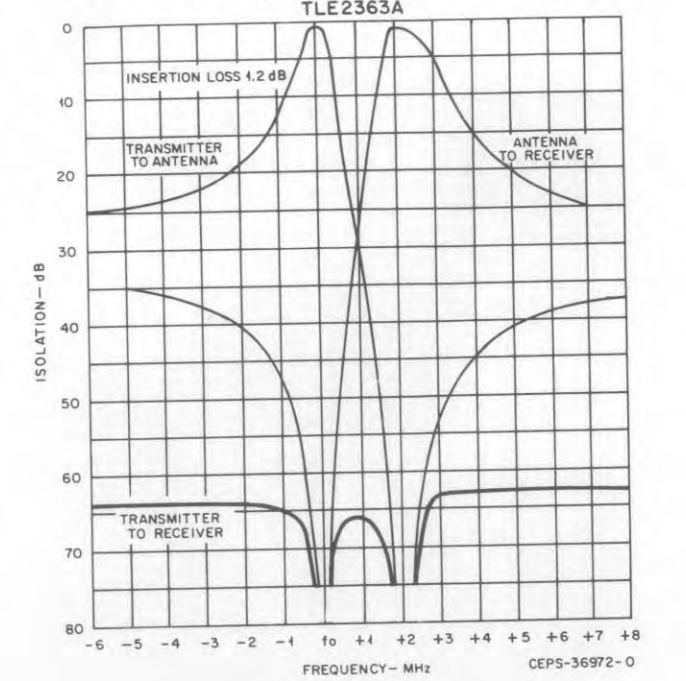

Mechanical Detail Photographs,
Selectivity Curves, and Parts Lists
Motorola No. PEPS-37324-O
8/19/83-PH1

DUPLEXER

MSR 2000™ BASE (RA), REPEATER (RA), & GUARD TONE KEYING CONFIGURATIONS

OPTION C150, C160, AND C170 SERIES

1. DESCRIPTION AND APPLICATION

1.1 INTRODUCTION

1.1.1 The options described in this instruction section are designed to provide for the remote control of a base station which, because of its location, cannot be economically connected via a wire line pair to the control point. Mountain top sites or locations in uninhabited regions (where no telephone lines exist) are typical examples of base station sites which need to be controlled using specialized radio equipment instead of a wire line pair.

1.1.2 By definition, an "RA" link (part of a "radio repeater (RA) system") is the radio equipment required to replace the usual wire-line control when operating a remote base station from its control point. The remote base station is termed an RA base. The repeater station that controls the RA base is called an RA repeater. It is co-located with the RA base and interconnected by a single, multi-conductor cable (customer supplied). A console and/or control station is located where the normal dispatch operations are carried out. See Figures 1 and 2.

1.1.3 RA links usually operate on 72 MHz, 450 MHz, or 960 MHz. Within the United States, the Federal Communications Commission (FCC) has certain restrictions making it difficult to license a 72 MHz RA link within 80 miles of a channel 4 or 5 TV station, or a UHF RA link within 75 to 100 miles of a metropolitan area with a population 200,000 or more.

1.2 BASE (RA) OPTION C150

1.2.1 The base (RA) option C150 can be used with all *MSR 2000*, single receiver, dc or tone remote control base station models in the 132-174 MHz, or 450-512 MHz frequency bands. The base (RA) option cannot be used with repeater (RT) models.

1.2.2 The *MSR 2000* base (RA) station may be connected to an RA link made up of *MICOR* stations. Refer to the Interconnect Diagrams provided at the end of this section.

1.2.3 The base (RA) option adds a squelch gate module which keys the companion repeater (RA) station when a message is received at the base (RA) station. The squelch gate module provides a PTT function

MSR 2000 and Micor are trademarks of Motorola, Inc.

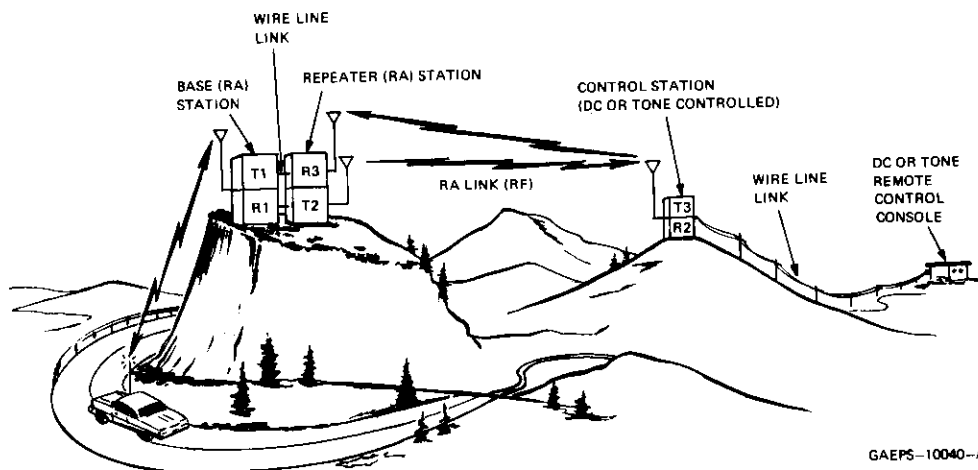

Figure 1. Typical Repeater (RA) System

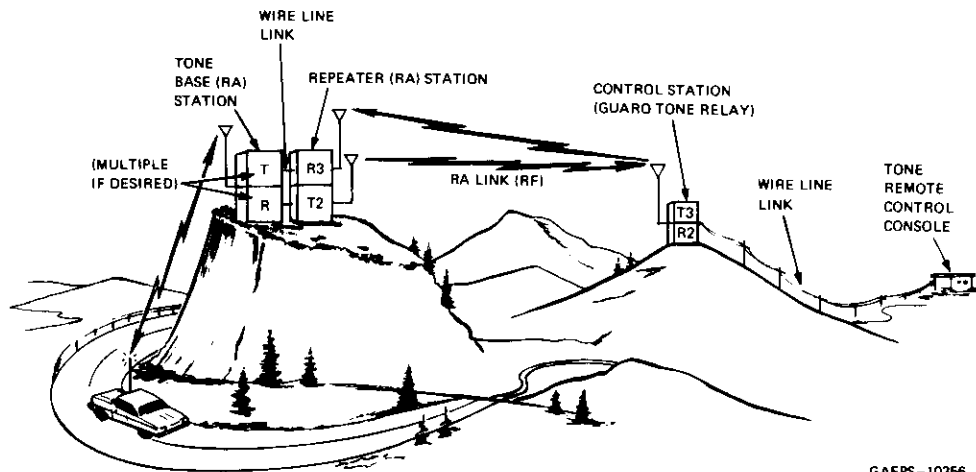

Figure 2. Typical Guard Tone Relay System

(switched ground) to the repeater (RA) station when the receiver in the base (RA) station quiets (receives a message).

1.2.4 When the station is converted for base (RA) operation, separate wire-line remote control is not required. Control is via rf from the control dispatch point or mobile with the control point given priority. This does not involve further model complement change concerning tone remote control models, but does remove the dc transfer module in dc remote control models.

1.2.5 RA link equipment (Base (RA)-Repeater (RA) stations) is used in two basic systems — “Repeater (RA) Systems” and “Guard Tone Relay Systems.” Both systems are used where extended range operation is required, or where natural or man made limitations to direct communications are encountered.

1.3 REPEATER (RA) OPTION C160

1.3.1 The repeater (RA) option C160 may be used with either MSR 2000 or Micor™ 450-512 MHz repeater (RT) models (PL or carrier squelch). Note that either a duplexer or separate receive and transmit antennas are required on an RA repeater station to satisfy FCC rules and regulations for dispatcher priority.

1.3.2 A repeater (RA) station in conjunction with a base (RA) station and two or more remote stations, such as a mobile station and a control station, together form a “radio repeater (RA) system”. See Figure 1.

1.3.3 The repeater (RA) - base (RA) combination has two modes of operation. It can: (1) receive and re-transmit a message from a control station to a mobile station; and, (2) receive and re-transmit a message from a mobile station to a control station.

1.3.4 The mobile units and the base (RA) station operate on frequency F1. The repeater (RA) station transmits on frequency T2 and receives on frequency R3. The control station transmits on frequency T3 and receives on frequency R2.

1.3.5 When the control station calls the mobile unit, the repeater (RA) turns on the base (RA) station transmitter. When receiver quieting of the repeater (RA) station reaches a predetermined level, the squelch gate in the repeater (RA) station actuates. This keys the transmitter in the base (RA) station. Audio is routed from the repeater (RA) station’s receiver to the base (RA) station’s transmitter audio input. The control station (dispatcher’s) message is then sent to the mobile units on frequency T1 by the base (RA) station’s transmitter.

1.3.6 When a mobile station calls the control station (dispatcher), the base (RA) station turns on the repeater (RA) station’s transmitter. (When receiver quieting of the base (RA) stations reaches a predetermined level, the squelch gate in the base (RA) station actuates. This keys the transmitter in the repeater (RA) station.) Audio is routed from the base (RA) station’s receiver to the repeater (RA) station’s transmitter audio input. The mobile station’s message is then sent to the control station on frequency T2 by the repeater (RA) station’s transmitter.

1.3.7 The control station has operational priority of the base (RA) station. The dispatcher can seize control of the RA system even through a mobile transmission is in process. The control station transmits on T3. Repeater (RA) receiver (R3) is always fully operational, and will, when its receiver quieting reaches a predetermined level, cause the base (RA) station to key, over-riding the mobile.

1.4 GUARD TONE RELAY OPTION C170

1.4.1 A guard tone relay system is much like the usual "RA" system -- with greatly expanded control capability.

1.4.2 In the repeater (RA) system (refer to Figure 1) a received message at the repeater (RA) station actuates the squelch gate in that station. This keys the companion base (RA) station which retransmits the message to mobile units. Only transmitter turn-on and turn-off control of the base (RA) station is possible in a repeater (RA) system, determined by receiver quieting and the squelch gate module in the repeater (RA) station.

1.4.3 In the guard tone relay system (see to Figure 2), the presence of an rf signal *alone* at the repeater (RA) station does NOT cause the companion station to transmit. Instead, the companion station is controlled via tone signals, just as if it were connected directly to a remote control console by wire lines. This permits multiple frequency operation, PL disable (PL or DPL coded squelch models), unique function commands, etc., of the companion base (RA) station.

1.4.4 For example, should the tone remote control console operator (dispatcher) want to talk to a mobile unit on frequency T4, a high level guard tone signal burst is applied to the control station. The control station keys *immediately* on frequency T3 and transmits the remaining *guard tone* signal to the repeater (RA) station. The repeater (RA) station applies this high level guard tone signal to the audio input of the companion tone remote control base (RA) station, which is then ready to accept and react to the forthcoming T4 function tone. The flexibility and number of functions in the guard tone relay system is limited only by the sophistica-

tion of the companion tone remote control base (RA) station and the remote control console. It should be noted that a squelch gate is used in the repeater (RA) station in this guard tone application to provide a transmitter channel element ground when the station is keyed. This is necessary since neither an F1-CS (carrier squelch) or F1-PL control module is used, which would otherwise supply the ground. The squelch gate is NOT used to key the companion base (RA) station.

NOTE

The transmit time of the high level guard tone burst sent by the remote control console should be lengthened to compensate for the delay time encountered in the keying of the guard tone relay station. Refer to the tone remote control console instruction manual for details.

2. CONNECTIONS BETWEEN BASE (RA) AND REPEATER (RA) STATIONS

The base (RA) station is connected to a companion repeater (RA) station via a single, multi-conductor cable (customer supplied). Since the cable is normally short and within the same installation site room, the usual telephone company line restrictions do not apply; adjust audio levels at +14 dBm. Control functions are also carried by direct connections. Connect the base (RA) station to the companion repeater (RA) station. Refer to Interconnect Diagrams provided at the end of this section.

NOTE

Antenna and power connections are not changed by the use of the base (RA) conversion.

**COMMERCIAL WARRANTY
(STANDARD)**

Motorola radio communications products are warranted to be free from defects in material and workmanship for a period of ONE (1) YEAR, (except for crystals and channel elements which are warranted for a period of ten (10) years) from the date of shipment. Parts, including crystals and channel elements, will be replaced free of charge for the full warranty period but the labor to replace defective parts will only be provided for One Hundred-Twenty (120) days from the date of shipment. Thereafter purchaser must pay for the labor involved in repairing the product or replacing the parts at the prevailing rates together with any transportation charges to or from the place where warranty service is provided. This express warranty is extended by Motorola Communications and Electronics, Inc., 1301 E. Algonquin Road, Schaumburg, Illinois 60196, to the original purchaser only, and only to those purchasing for purpose of leasing or solely for commercial, industrial, or governmental use.

THIS WARRANTY IS GIVEN IN LIEU OF ALL OTHER WARRANTIES EXPRESS OR IMPLIED WHICH ARE SPECIFICALLY EXCLUDED, INCLUDING WARRANTIES OF MERCHANTABILITY OR FITNESS FOR A PARTICULAR PURPOSE. IN NO EVENT SHALL MOTOROLA BE LIABLE FOR INCIDENTAL OR CONSEQUENTIAL DAMAGES TO THE FULL EXTENT SUCH MAY BE DISCLAIMED BY LAW.

In the event of a defect, malfunction or failure to conform to specifications established by seller, or if appropriate, to specifications accepted by Seller in writing, during the period shown, Motorola, at its option, will either repair or replace the product or refund the purchase price thereof, and such action on the part of Motorola shall be the full extent of Motorola's liability hereunder.

This warranty is void if:

- a. the product is used in other than its normal and customary manner;
- b. the product has been subject to misuse, accident, neglect or damage;
- c. unauthorized alterations or repairs have been made, or unapproved parts used in the equipment.

This warranty extends only to individual products, batteries are excluded, but carry their own separate limited warranty. Because each radio system is unique, Motorola disclaims liability for range, coverage, or operation of the system as a whole under this warranty except by a separate written agreement signed by an officer of Motorola.

Non-Motorola manufactured products are excluded from this warranty, but subject to the warranty provided by their manufacturers, a copy of which will be supplied to you on specific written request.

In order to obtain performance of this warranty, purchaser must contact its Motorola salesperson or Motorola at the address first above shown, attention Quality Assurance Department.

This warranty applies only within the United States.

EPS-27734-O

COMPUTER SOFTWARE COPYRIGHTS

The Motorola products described in this instruction manual may include copyrighted Motorola computer programs stored in semiconductor memories or other media. Laws in the United States and other countries preserve for Motorola certain exclusive rights for copyrighted computer programs, including the exclusive right to copy or reproduce in any form the copyrighted computer program. Accordingly, any copyrighted Motorola computer programs contained in the Motorola products described in this instruction manual may not be copied or reproduced in any manner without the express written permission of Motorola. Furthermore, the purchase of Motorola products shall not be deemed to grant either directly or by implication, estoppel, or otherwise, any license under the copyrights, patents or patent applications of Motorola, except for the normal non-exclusive, royalty free license to use that arises by operation of law in the sale of a product.

EPS-34440-B

68P81112E94-B

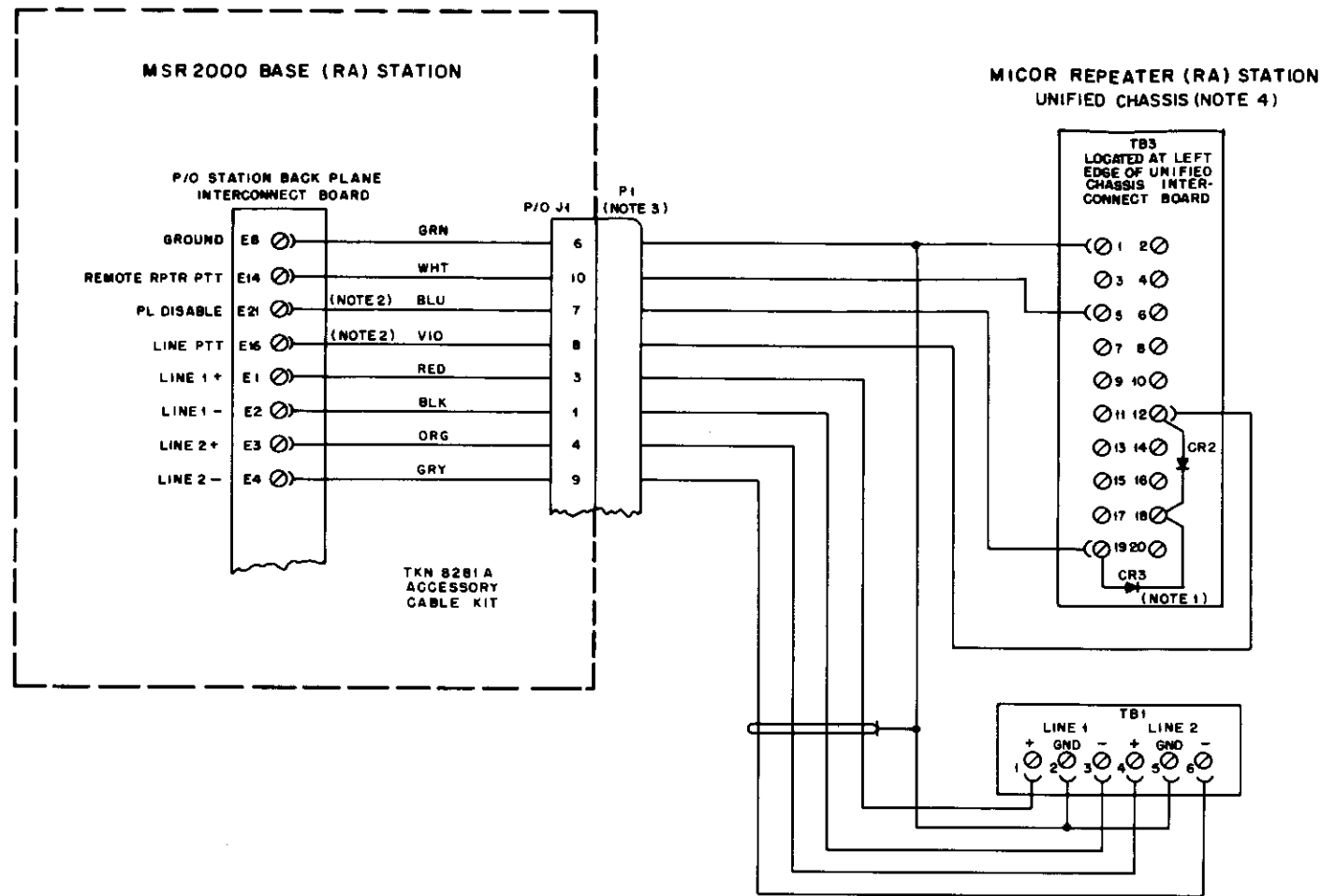

CAUTION
REMOVE DIODE CR15 AND RESISTOR R59 IN SQUELCH GATE MODULES OF BOTH STATIONS WHEN RELAY KI IS NOT USED.

- NOTES:**
- IF PL/DPL DISABLE IS REQUIRED, CR2 AND CR3 (MOTOROLA PART NO. 48-B2392 B03) SHOULD BE INSTALLED ON THE REPEATER (RA) STATION. THE 5-SECOND JUMPER (JU1) IN THE SINGLE TONE DECODER MODULE MUST BE REMOVED.
 - "LINE PTT" AND "PL DISABLE" LINES ARE NOT CONNECTED IN GUARD TONE RELAY APPLICATIONS.
 - CONNECTOR P1 IS SUPPLIED WITH MSR 2000 BASE (RA) STATION, AS PART OF TKN 8281A KIT. INTERSTATION CABLING IS NOT SUPPLIED.
 - FOR REPEATER (RA) STATIONS OTHER THAN SHOWN REFER TO APPROPRIATE REPEATER (RA) STATION MANUAL. INTERCONNECT MATCHING FUNCTIONS.

CEPS-34869-0

parts list

TKN8281A Auxiliary Interconnect Cable PL-8067-O

REFERENCE SYMBOL	MOTOROLA PART NO.	DESCRIPTION
J1	9-84538E03	connector, receptacle: female; 25-contact
mechanical parts		
	2-84588C01	NUT, machine; 4-40; square; 2 used
	3-129674	SCREW, machine; 4-40 x 3/16"; 2 used
	29-812979	LUG, crimp terminal; 10 used
	42-10217A02	STRAP, tie; 12 used
	30-86970A02	CABLE; 10 conductor; 46" used
	43-10646A09	SPACER; 2 used
	28-84506E08	CONNECTOR, male; 25-contact
	15-82486M01	HOOD

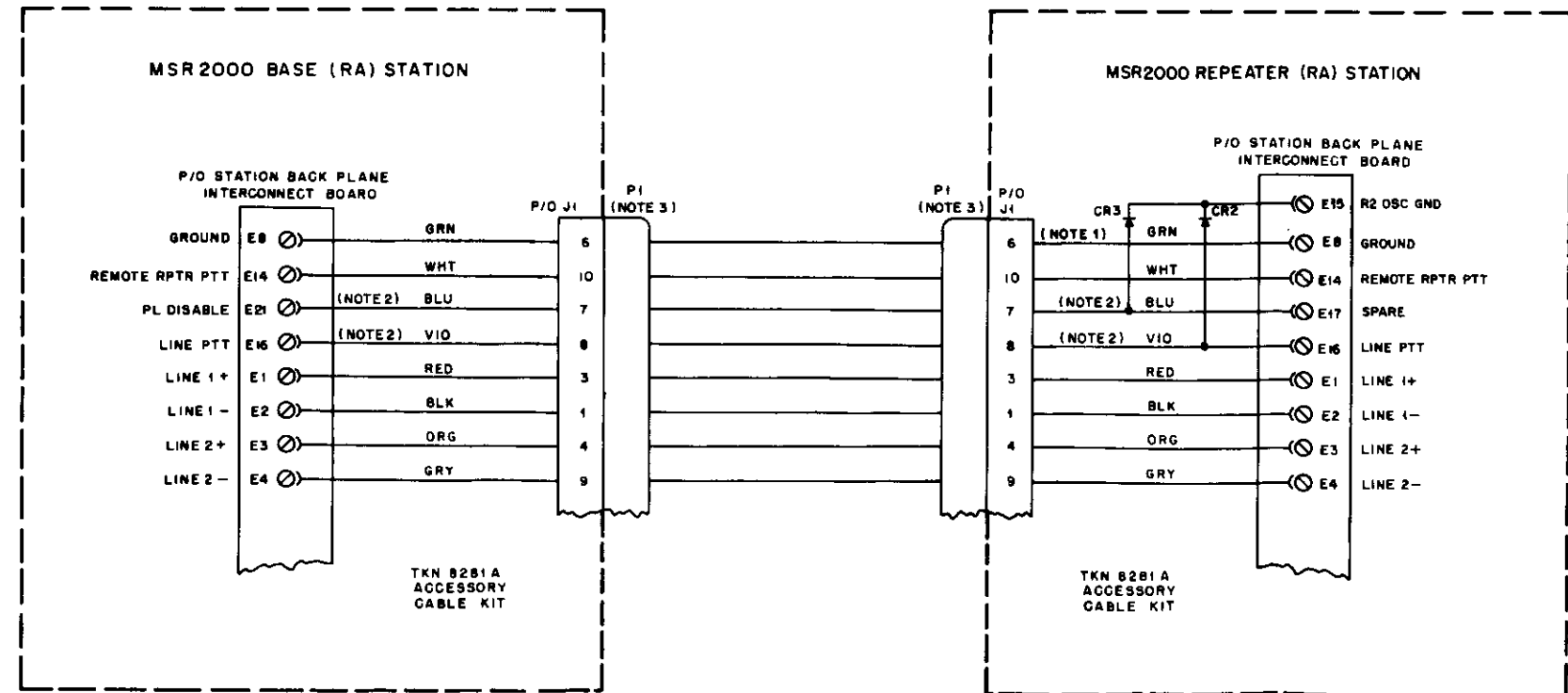

CAUTION
REMOVE DIODE CR15 AND RESISTOR R59 IN SQUELCH GATE MODULES OF BOTH STATIONS WHEN RELAY KI IS NOT USED.

- NOTES:**
- IF PL/DPL DISABLE IS REQUIRED, CR2 AND CR3 (MOTOROLA PART NO. 48-B2392 B03) SHOULD BE INSTALLED ON THE REPEATER (RA) STATION. THE 5-SECOND JUMPER (JU1) IN THE SINGLE TONE DECODER MODULE MUST BE REMOVED.
 - "LINE PTT" AND "PL DISABLE" LINES ARE NOT CONNECTED IN GUARD TONE RELAY APPLICATIONS.
 - CONNECTOR P1 IS SUPPLIED WITH EACH MSR 2000 RA STATION, AS PART OF TKN 8281A KIT. INTERSTATION CABLING IS NOT SUPPLIED.

CEPS-36780-0

*Base (RA) To Repeater (RA)
Station Interconnect Diagrams and Parts List
Motorola No. PEPS-37325-O
8/19/83-PHI*

OPTION C-150 AND C-170 SERIES

Superceded by
rev. B

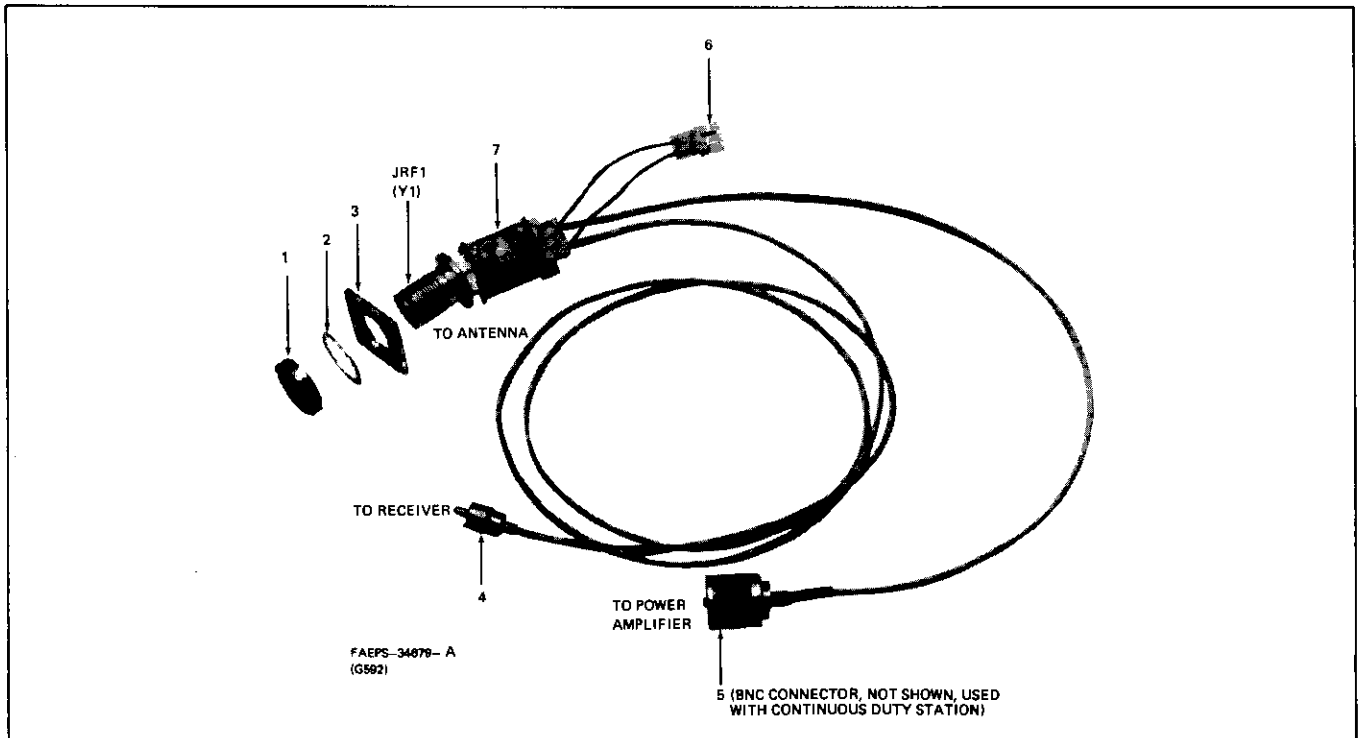

ANTENNA SWITCH REPLACEMENT

1. Remove the card cage per manual instructions in the maintenance section.
2. Note the positions of the tie wraps and cable clamps, and pay attention to cable routing.
3. Remove the appropriate cable clamps, and clip the necessary tie wraps.
4. Remove the antenna switch:
 - 4.1 Unfasten the receiver antenna connector from the card cage chassis (2 screws).
 - 4.2 Disconnect the rf connector from the PA output.
 - 4.3 Unfasten the 2 pin molex connector.

- 4.4 Remove the antenna switches spanner nut from the junction box.
5. Installation is the reverse of the above. Remember to fasten the cables with new tie wraps.

parts list

REFERENCE SYMBOL	MOTOROLA PART NO.	DESCRIPTION
1	2-80006A01	NUT, spanner
2	4-114522	LOCKWASHER, 5/8"
3	43-82895N01	SPACER
4	28-82875N01	CONNECTOR, receiver
5	28-84579F01	CONNECTOR, PA (P03) Intermittent Duty
	28-83099K01	CONNECTOR, PA (P803) continuous duty
6		J801 consists of 15-94861K02 Housing
		29-84708E05 TERMINALS
7		ANTENNA SWITCH, non-serviceable

ANTENNA SWITCH