

NHRC

REPEATER CONTROLLERS

NHRC-4/MVP

USER GUIDE

Software Version: 2.2

User Guide Version: 2003-Mar-12

Copyright Notice

Copyright © 2000, 2001, by NHRC LLC

This document contains proprietary information, which is the confidential property of NHRC LLC.

No part of this document may be used or reproduced, by any means, or for any purpose, without the expressed written consent of NHRC LLC.

No part of this document should be considered to be specifications for the proper or correct operation of the NHRC-4/MVP Repeater Controller. In no way will NHRC LLC be liable for direct or indirect damages to the controller or attached equipment.

Printed in the U.S.A.

Thank You!

Thank you for purchasing the NHRC-4/MVP Repeater Controller. This controller has been designed using the very latest state-of-the-art technology. Please review this manual carefully before putting your controller into operation.

This manual represents a very large documentation effort. Your comments are important to us. If you find an error or find any passages that are not clearly understandable we would like to hear about it. Please send your comments to ***software@nhrc.net***.

Support for the controller is available by email or telephone. Please direct software-related questions via email to ***software@nhrc.net***. Please direct hardware-related questions via email to ***hardware@nhrc.net***. Your question(s) will be answered promptly.

Questions of a more urgent nature can be answered by telephone support. Telephone support is available Monday through Friday, from 6 PM until 10 PM, Eastern Time.

Table Of Contents

1. INSTALLATION.....	2
1.1 J4 PRIMARY RADIO PORT CONNECTIONS.....	2
1.2 J3 SECONDARY RADIO PORT CONNECTIONS.....	3
1.3 JTS64 PRIMARY RADIO PORT TS-64 CONNECTOR.....	3
1.4 J1 & J2 DAD CONNECTORS.....	4
1.5 THE LED STATUS INDICATORS.....	5
1.6 USING THE DIGITAL OUTPUT.....	5
1.7 ADJUSTING THE AUDIO LEVELS.....	5
2. GE CUSTOM MVP FULL-DUPLEX MODIFICATION	7
2.1 BEFORE YOU BEGIN	7
2.2 DUPLEX MODIFICATIONS.....	7
2.2.1 <i>Multi-Channel Radios</i>	7
2.2.2 <i>Antenna Connections</i>	7
2.2.3 <i>Simultaneous Transmit and Receive Modification</i>	7
3. CONTROLLER INSTALLATION AND HOOKUP	11
4. OPERATING THE NHRC-4/MVP	12
4.1 INTRODUCTION	12
4.2 INITIALIZING THE CONTROLLER.....	13
4.3 PROGRAMMING THE CONTROLLER.....	14
4.4 PROGRAMMING THE TIMERS	14
4.5 PROGRAMMING THE CW MESSAGES	15
4.6 PROGRAMMING THE FLAG BITS	15
4.7 PROGRAMMING THE COURTESY TONES	17
4.8 PREVIEWING STORED CW MESSAGES	18
4.9 ENABLING/DISABLING THE REPEATER.....	18
4.10 USING THE NHRC-DAD DIGITAL AUDIO DELAY WITH THE NHRC-4/MVP REPEATER CONTROLLER.....	19
4.11 PROGRAMMING EXAMPLE.....	19
5. APPENDICES.....	21
5.1 TABLES.....	21
5.1.1 <i>Message Contents</i>	21
5.1.2 <i>Programming Memory Map</i>	21
5.1.3 <i>Morse Code Character Encoding</i>	23
5.2 TERMINOLOGY AND ABBREVIATIONS	24
6. CIRCUIT BOARD	25
6.1 INTERCONNECTIONS	25
7. SCHEMATICS	27
8. PARTS LIST	30
NHRC LLC LIMITED WARRANTY	32

NHRC-4/MVP User Guide

1. Installation

This section of the User Guide describes the electrical interfaces used to connect the controller to:

- Power and primary repeater (the GE Custom MVP),
- Link/Remote Base radio
- Communications Specialists TS-64 CTCSS Encoder/Decoder
- *Optional* NHRC-DAD digital audio delay board(s).

It is intended for the repeater operator to use in the planning and installation of the NHRC-4/MVP Repeater Controller into a repeater system.

The controller uses an 8 pin 0.100" header for all the primary radio's signals and DC power, a 6 pin 0.100" header for the secondary radio's signals, and a 6 pin 0.100" header for an external TS-64 CTCSS encoder/decoder for the primary radio. In addition, it has two 4 pin 0.100" connectors to support optional NHRC-DAD digital audio delays for both radio ports.

Each radio port requires audio and a signal present indication (CAS) from its receiver, and supplies transmit audio and PTT to its transmitter. The controller requires 13.8 volts DC for power, which is provided on the primary radio's connector. Be very careful when wiring DC power to the controller, reverse polarity will severely damage the controller. The connector pinouts are shown in the tables below.

Consult sections 2 and 3 for specific Custom MVP modification and installation instructions.

1.1 J4 Primary Radio Port Connections

Receiver audio can typically be taken from the high side of the squelch control. This audio must be de-emphasized with the controller's de-emphasis circuit, which provides a 6dB/octave slope. Optionally, audio can be taken from later in the receiver's audio chain, where it is already de-emphasized. Care must be taken that this source of audio is not subject to adjustment by the radio's volume control. If the receiver audio has not been properly de-emphasized, either in the receiver itself or on the controller board, the repeater will have a very "tinny", unnatural sound to it. The NHRC-4/MVP repeater controller is shipped with the de-emphasis circuit populated on the printed circuit board for main repeater audio and without de-emphasis for remote base audio for "flat" audio response. To install the de-emphasis filter for the remote base audio, two 100K ohm resistors must be removed (R10 and R11), and a replaced with a 10K ohm at R11, a 93.1K ohm at R10, and a 0.0068 microfarad capacitor at C10 must be installed on the board. Consult the NHRC-4/MVP Repeater Controller (Audio) schematic as a reference for the modification.

The receiver must provide a signal present indication (also called CAS, COR, RUS) to the controller. The controller requires an "active-high" signal here. If your radio only has "active-low" signaling available, a simple inverter can be constructed with a 2N3906 and a 4.7K resistor. Connect the emitter of the transistor to a source of positive voltage, the collector to the controller's CAS terminal, and the base to the active-low signal through the 4.7K resistor.

NHRC-4/MVP User Guide

Transmitter audio can be fed directly into the microphone input of the transmitter. VR5 is the master level control for the primary radio, used to set the audio level into the transmitter. VR6 is the master level control for the secondary radio. The transmitter's deviation limiter (sometimes called IDC) should be set such that the transmitter cannot overdeviate, regardless of input signal level. One way to adjust transmitter deviation is to set the transmitter deviation limiter wide open (unlimited), adjust the controller's master output until the transmitter is slightly overdeviating, then set the transmitter's deviation limiter to limit just below 5 KHz deviation. Then reduce the controller's master output until the transmitted audio does not sound compressed or clipped. Transmitter deviation should be adjusted with a service monitor or deviation meter.

Transmitter keying is provided by a power MOSFET (Q1/Q9) configured in an open-drain circuit. This can be used to key many transmitters directly. The MOSFET essentially provides a closure to ground for PTT. For other transmitters, the MOSFET can drive a small relay to key the radio. Although this MOSFET can handle several amps, we recommend that no more than 500 mA of current be drawn through it.

J4 Primary Radio Port ("REPEATER")

Pin	Use
1	+13.8 Volts
2	CAS (active high)
3	PTT (active low)
4	Receiver Audio
5	Transmitter Audio
6	Fan/Digital output (active low)
7	Ground/Audio Return
8	Ground/Audio Return

1.2 J3 Secondary Radio Port Connections

J3 Secondary Radio Port ("REMOTE BASE")

Pin	Use
1	CAS (active high)
2	PTT (active low)
3	CTCSS detect (active high)
4	Receiver Audio
5	Transmitter Audio
6	Ground/Audio Return

1.3 JTS64 Primary Radio Port TS-64 Connector

Connector JTS64 is a 6pin header that allows the easy installation of an optional Communications Specialists TS-64 for CTCSS decode and encode. Consult table JTS64 for hookup information.

NHRC-4/MVP User Guide

The TS-64 must have the JU-2 jumper cut. If you want to be able to disable the CTCSS requirement, install a switch on the HANGUP lead, or you could wire the HANGUP lead to the J4 Fan/Digital Output pin to allow remote enable/disable of the CTCSS requirement. If you like, you can wire the TS-64's ENCODE OUT pin into your transmitter's CTCSS input to encode PL on the repeater's output.

The TS-64 is normally configured with its high-pass filter in-circuit to remove received CTCSS tones. Jumper JP2 on the controller board must be removed when the TS-64 high-pass filter is used. If the TS-64 is not installed, then jumper JP2 must be installed in order for audio to pass through the controller.

Adjust the CTCSS deviation with R20 on the TS-64 board. The ideal deviation for the CTCSS tone is 750 Hz. Consult the TS-64 INSTRUCTION SHEET for details on setting the CTCSS frequency.

JTS64 Primary Radio Port TS-64 Connector

Pin	Use	to TS-64 Signal
1	+13.8 Volts	+13.8V In
2	Receiver Audio	Decoder In
3	Receiver Audio	N/C
4	Filtered Audio	High Pass Filter Out
5	CTCSS Detect	RX Mute & Decoder Out
6	Ground / Audio Return	Ground & PTT Input & Hangup

1.4 J1 & J2 DAD Connectors

The audio delay for the primary radio simply plugs in to J4. The audio delay for the secondary radio plugs in to J5. If the audio delay is not installed, a jumper between pins 2 and 3 of the port's delay connector must be installed, or the controller will not pass audio.

J2 Primary Radio DAD ("DELAY ")

J1 Secondary Radio DAD ("RB DELAY ")

Pin	Use
1	+13.8 Volts to Delay Board
2	Audio to Delay Board
3	Audio from Delay Board
4	Ground/Audio Return

NHRC-4/MVP User Guide

1.5 The LED Status Indicators

The NHRC-4/MVP repeater controller is equipped with five status LED's that aid in setup and troubleshooting. There are green LED's for each radio port (D2 and D4) that indicate that the controller has getting a valid CAS (carrier operated switch) and, if a CTCSS decoder is connected, a valid CTCSS decode signal. This LED should light when the repeater's receiver is active, and, if a CTCSS decoder is present, that the correct CTCSS tone is present. The yellow LED (D1) indicates that a DTMF signal is being decoded on the primary receiver. This LED should light for the entire duration that the DTMF signal is present on the primary receiver. The red LED's (D3 and D5) indicate transmit. These LED's will light when the each transmitter is transmitting.

The LED's can be disabled to reduce the power consumption of the controller. Remove jumper JP3 to disable the LED's.

1.6 Using the Digital Output

The NHRC-4/MVP Repeater Controller has a digital output that can be used for various remote control applications or to control a fan on the repeater's transmitter. The digital output is an open-drain into a power MOSFET, which is capable of sinking quite a bit of current, but we recommend a maximum load of about 500 mA. Use a relay to drive larger loads. The open-drain output can be used to gate the HOOKSWITCH signal to a TS-64 or other CTCSS decoder. Software allows the output to be enabled, disabled, or pulsed. In fan control mode, this output will be turned on when the transmitter is turned on, and turned off a programmable amount of time after the transmitter is turned off.

1.7 Adjusting the Audio Levels

Audio Level Adjustments

Potentiometer	Use
VR1	Primary Receiver Level
VR2	Secondary Receiver Level
VR3	Primary Receiver Mix Level
VR4	Beep Tone Mix Level
VR5	Primary Transmitter Master Level
VR6	Secondary Transmitter Master Level

Preset all potentiometers to midrange. Key a radio on the primary input frequency, send some touch-tones, and adjust VR1 (the primary receiver level) until DTMF decoding is reliably indicated by yellow LED (D1).

NHRC-4/MVP User Guide

The primary radio's transmit deviation is set with VR5 (the primary transmitter master level) on the controller board and the transmitter's deviation/modulation control. The key to properly adjusting these controls is to remember that the limiter in the transmitter is *after* VR5 but probably *before* the transmitter's deviation/modulation control. The transmitter's deviation/modulation control will set the actual *peak* deviation, and VR5 will set the level into the transmitter. You do not want excessive limiting on normal speech going through the repeater; it sounds bad and tends to "pump-up" background noise. On the other hand, some limiting is desirable. An oscilloscope connected to the audio output of a receiver tuned to the transmitter's frequency will show limiting as the audio gets "flat-topped" or clipped by the limiter. Ideally, a 4.5KHz deviation signal input to the repeater should result in a 4.5 KHz deviation output, and 5.5 KHz of input deviation should result in just under 5.0 KHz of deviation out of the repeater. A service monitor (or two), deviation meter, and/or a signal generator are necessary to do this job right.

The secondary radio's transmit deviation is set with VR6 (the secondary transmitter master level). Enable the secondary transmitter, and adjust VR6 for proper transmit deviation, similarly to VR5.

Enable the secondary receiver, and adjust VR2 for reasonable deviation on the enabled transmitters when a signal is received on the secondary receiver.

Adjust VR4 (the beep level) to set the courtesy tone and CW tone level.

VR3 is used to set the receiver audio mix level, and may not need to be adjusted from midpoint.

2. GE Custom MVP Full-Duplex Modification

2.1 Before You Begin

Before you begin with the duplexing modifications and installation of the NHRC-4/MVP repeater controller, it is imperative that you verify that your Custom MVP operates correctly. This will reduce the amount of time you may have to spend troubleshooting if you do run into problems with the radio modifications or controller installation.

NHRC assumes no liability for any damages to your Custom MVP or your inability to perform these modifications. If you have any doubt about your ability to correctly perform the modifications or to install the repeater controller seek professional assistance. Damage to your Custom MVP and/or NHRC-4/MVP repeater controller caused by improper installation or hookup is not covered by the NHRC limited warranty.

We strongly recommend that you have access to a service manual for your Custom MVP, it is nearly impossible to properly modify, tune, and maintain the radio without one.

This document is the only support available for duplexing the Custom MVP. No other assistance is available from NHRC regarding duplexing this radio.

2.2 Duplex Modifications

2.2.1 Multi-Channel Radios

If your MVP is a multi-channel radio, you will probably want to disable the channel selector and select channel 1 (F1) with a jumper installed on the Oscillator/Multiplier board. Consult the Service Manual for this jumper location.

2.2.2 Antenna Connections

In order to use the Custom MVP in duplex operation, a separate antenna lead must be brought out of the radio for the receiver antenna connection. Remove the jumper between the T/R Relay board and the receiver input, which is located inside the RF assembly casting. Drill a 1/4" hole adjacent to the SO-239 antenna connection, making sure you leave sufficient room to put the cover back on the radio. Route a piece of double-shielded coax through the hole. We recommend that you use RG-142, RG-223, or RG-400 cable here. Solder a RCA plug onto the end of the cable inside the radio, and plug it into the receiver antenna jack. Install the connector of your choice on the other end of this cable. This will serve as your receiver antenna input.

2.2.3 Simultaneous Transmit and Receive Modification

The rest of the duplexing modifications are performed on the System-Audio-Squelch (SAS) board. The SAS board is located behind the front panel of the radio. Remove the front panel to access the SAS board.

NHRC-4/MVP User Guide

The SAS board is shown below.



Remove the GE “Channel Guard” (CG) module if it is installed. The CG module is located next to the SAS board, and can be identified by the lack of any connectors on the board. Unplug the CG boards connections to the SAS board. Cut off or completely remove the CG encoder cable that runs from the CG board to the exciter. You may want to keep the cables and plugs from the CG board, they may come in handy when interfacing the needed repeater signals to the radio after all duplexing modifications have been performed.

Remove the SAS board from the radio. These boards vary slightly from revision to revision but are fundamentally the same. Remove the 2 screws on the audio amp IC heat sink. Remove the screw from the voltage regulator TO-220 transistor. Note the insulators over and under this transistor, they must be re-installed later. Make note of the connections you disconnect. The front panel assembly can be removed by unplugging the cabling and setting it aside out of your way.

Defeat the RX oscillator control circuit. Find and cut the PCB trace that connects J904 pin 2 to hybrid IC U902 pin 7. Refer to the service manual PCB layout. It is best to cut this trace on the bottom of the PCB. There is a via and a small segment of trace leading to pin 7 of the hybrid. Cut the trace between the via and hybrid with an X-Acto knife. See picture below:

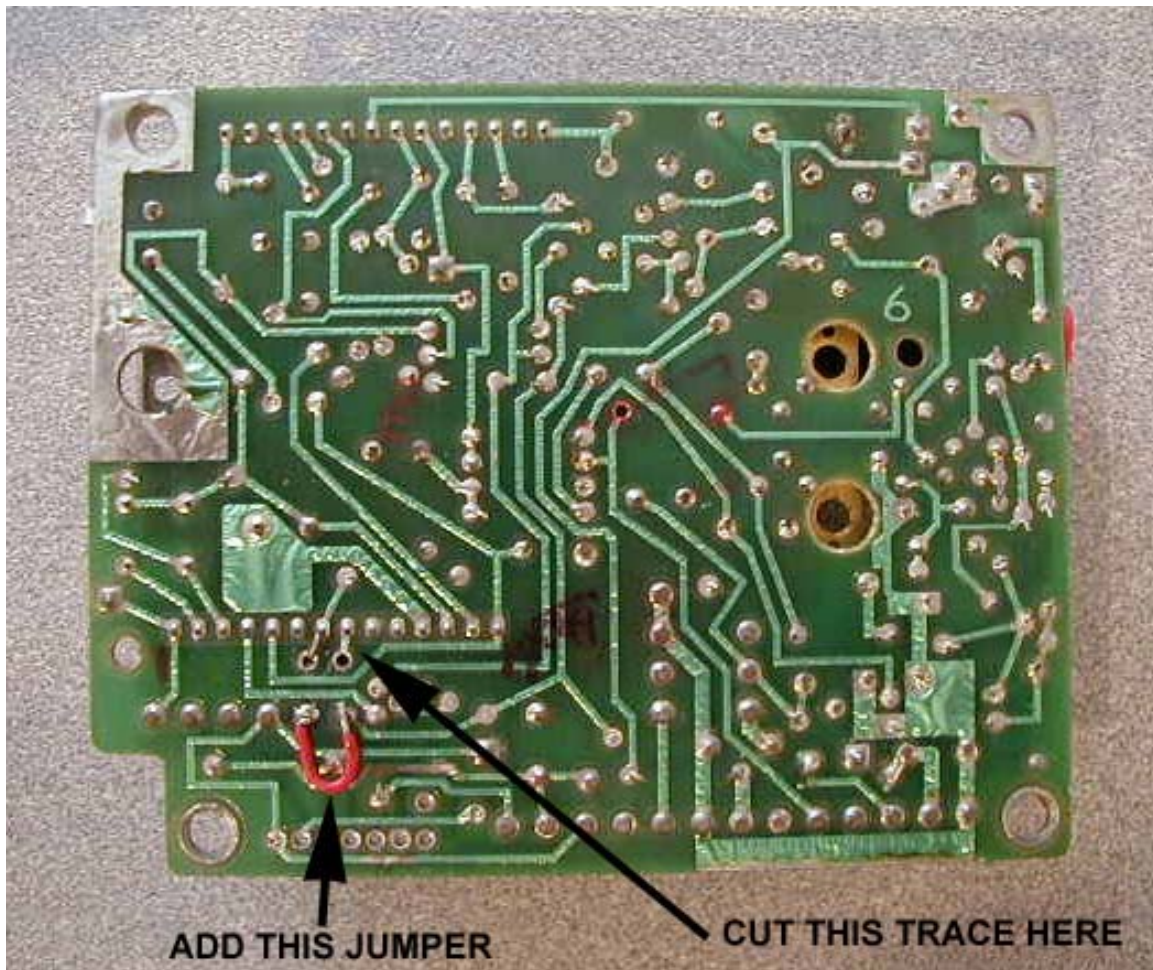

Strap the RX oscillator always on by placing 10V on the RX oscillator control line. You can do this by installing a jumper from J904 pin 1 to J904 pin 2. See the picture for the jumper location.

Defeat the RX mute circuit at U902 pin 6. Cut the trace from U902 pin 6 to J906 pin 5. It is best to cut this trace at the point that it makes an "S" pattern near pin 7 of J905 and H-11. This trace runs near a square post J-11. Be certain you are severing the proper connection or CAS circuit could be disabled. See picture below:



NHRC-4/MVP User Guide

If your radio had a CG board installed, you will need to Re install R33, a 1K ohm 1/4w resistor from H1 to H2. H1 and H2 are holes in the PCB just behind J906. Be certain the resistor lead does not contact and short against the square post J10. See picture below:



Your systems board duplexing modifications are now complete. Go back and carefully check your work.

Note: A .100-inch center header fits nicely into the row of holes denoted on the PCB as H11 through H17. You can install a header here so you can pickup the PTT line without soldering. Do this now before you install the System-Audio-Squelch PCB.

Re-install your System-Audio-Squelch PCB in the reverse order in which you removed it. Be careful to properly re-install the insulator over and under the TO-220 voltage regulator transistor. Install all other screws previously removed.

Re-test your MVP now. It should receive and transmit simultaneously now. If you have problem at this point do not proceed until you have the radio working correctly.

NHRC-4/MVP User Guide

3. Controller Installation and Hookup

Install your NHRC-4/MVP controller in place of the Channel Guard Encoder/Decoder you have discarded. Use the 3 screws leftover from the removal to mount your controller. If needed obtain some 6-32 X 1/4 inch pan head screws to mount your controller to the mounting bosses on the MVP.

Care must be taken to avoid shorting the transistors (Q1, Q6 and Q9) which are mounted on the end of the controller next to the inside of radio if your controller was factory assembled with non-insulated tab transistors or if you have replaced an insulated tab transistor with a non-insulated tab part. If so, the use of electrical tape or some other insulating material between the transistors and the radio is highly recommended.

Use connectors to make your connections to the controller and systems board. This will make your installation look professional and be more reliable. Controllers received for repair with solder on the header pins will have the header pins replaced at the *customer's expense*.

All connections to the controller are easily available on the System-Audio-Squelch PCB next to the controller.

NHRC-4/MVP J4 Pin #	Signal Name	Connection to Custom MVP
1	+10 VDC	+10 volts is available on the SAS board at J906 pin 6.
2	CAS	CAS is available from J906 pin 5 (was RX MUTE).
3	PTT	PTT is available at H17.
4	RX AUDIO (from Receiver)	The receiver audio is available at J906 pin 4 (VSQ-HI).
5	TX AUDIO (to Transmitter)	TX Audio is supplied to the white or yellowish-white wire that is or was connected to J13. If this is still connected to J13 disconnect it. <i>Note that this wire is MIC-HI and J13 is the MIC-BIAS voltage supply.</i> This disconnects the MIC bias and will defeat the external microphone. If a local microphone is desired, seek an alternate way to provide audio to the exciter. There may be audio loading issues with the local microphone.
6	DIGITAL OUTPUT/ FAN CONTROL	This connection is optional. If you desire to use this feature, the now unused hang up lead from the old channel guard board is an easy way to get this signal out of the radio. The channel guard hang-up lead comes out on the power/speaker jack on pin 8.
7	GROUND	Ground is available at J906 pin 1.

Connections are now complete for basic repeater operation.

Before powering on your repeater go back and check your work. ***Apply power with the controller disconnected and check your power supply connections.*** With a grounded probe touch the PTT pin, your MVP should transmit. Check to see that your CAS signal goes to approx 7 volts when the squelch opens and goes low when it closes.

4. Operating the NHRC-4/MVP

4.1 Introduction

The NHRC-4/MVP has 2 radio "ports", which are connectors that the radios connect to. There is a "primary" and a "secondary" radio port.

The "primary" radio port (J4) is where the "main" repeater connects. All DTMF commands must come from here. When the primary radio is disabled, the secondary radio is also disabled.

The "secondary" radio port (J3) is where the secondary radio connects. The secondary radio can be a remote base, link radio, or a second repeater, which when activated, is "married" to the primary repeater. The secondary radio can be disabled without any effect on the primary radio. No DTMF commands are accepted from this port.

The secondary radio can be a "Remote Base", which is a simplex radio connected to the repeater system that allows the repeater users to remotely operate on a different frequency / mode / band than the repeater.

The secondary radio can be a link radio to interconnect the repeater on the main port to a distant repeater. The link radio can be simplex or full-duplex. In the case of a full-duplex link, the main receiver and the link receiver can be repeated over both transmitters simultaneously. A simplex link will always transmit when the main receiver is active, potentially blocking any traffic that might be received over the link at that time.

The secondary port can be connected to a repeater that will "marry" or "slave" to the main repeater. Anything received on either repeater will be re-transmitted by both repeaters. This allows repeaters on two different bands to be easily and inexpensively linked.

The secondary port has several different modes of operation that apply to some or all of the applications described above. The secondary port's modes can only be selected by sending DTMF to the receiver connected to the primary radio port. These modes are:

- disabled
- alert mode
- monitor mode
- transmit mode

In disabled mode, the secondary radio port is ignored by the controller.

Alert Mode is a mode in which a different courtesy tone will be played if the receiver on the secondary port is unscquelched when the courtesy tone is requested. This is useful to indicate that traffic exists on a remote base frequency without having to hear the remote base traffic being repeated.

In monitor mode, the secondary radio's receiver audio is retransmitted over the primary repeater, but the secondary port is inhibited from transmitting. This mode is also useful for remote base operation and monitoring linked repeaters.

In transmit mode, the secondary radio's receiver audio is retransmitted by the primary radio, and the primary radio's audio is transmitted over the secondary radio. This mode is useful for remote bases, linked repeaters, and married repeaters.

NHRC-4/MVP User Guide

A married repeater requires that the controllers "secondary port is a duplex repeater" option be set. This option changes how the PTT line to the secondary radio port operates. Normally, the secondary radio port's PTT line follows the primary radio port's CAS (receiver active) line, that is the secondary port transmits when enabled and the primary receiver is active. When the "secondary port is a duplex repeater" option is set, the secondary radio port's PTT line follows the primary radio port's PTT line, so that the courtesy tone and tail are transmitted on the married repeater.

The controller's programming is protected from unauthorized access by a 4-digit secret passcode. The controller is programmed by 8-digit DTMF commands that all begin with the 4-digit passcode. Throughout this manual, commands will be shown as **ppppNNNN**, where **pppp** represents the passcode, and **NNNN** is the actual command to the controller.

In order to save space in the microprocessor memory, the NHRC-4/MVP repeater controller represents all numbers in "hexadecimal" notation. Hexadecimal, or "hex" for short, is a base-16 number format that allows an 8-bit number to be represented in two digits. Hex numbers are 0, 1, 2, 3, 4, 5, 6, 7, 8, 9, A, B, C, D, E, and F. Converting decimal (the normal base-10 numbers that 10-fingered humans prefer) to hex is simple. Divide the decimal number by 16 to get the 1st hex digit (10=A, 11=B, 12=C, 13=D, 14=E, 15=F), the remainder is the 2nd hex digit. For example, 60 decimal = 3 x 16 + 12 = 3C hex. Any decimal number from 0 to 255 may be represented in only 2 hex digits.

Many scientific calculators can convert between these two number systems, and the Windows 95 / 98 / 2000 calculator can, too, if the "scientific" view is selected. We provide a Web page that can generate all the programming data for the NHRC-4/MVP controller quickly and easily, see <http://www.nhrc.net/nhrc-4mvp/nhrc4prog.html>.

A 16 key DTMF pad has keys 0-9 and A-D, which map directly to their corresponding hex digits. Use the * key for digit E and the # key for digit F. A 16-key DTMF pad is required to program the controller.

Note: Programming of the NHRC-4/MVP must be transmitted to the radio attached to the primary radio port.

4.2 *Initializing the Controller*

The controller will need to be initialized to allow you to set your secret passcode. Initializing the controller also resets all programmable settings to the factory defaults, including the CW ID message. It should not be necessary to initialize the controller again, unless you want to change the passcode. The only way to change the passcode is to initialize the controller.

To initialize the controller, remove power and install the INIT jumper (JP1). Apply power to the controller, and after a few seconds, remove the init jumper. The controller is now in the initialize mode. If you "kerchunk" the primary port's receiver now, it will send the default CW ID of "DE NHRC/4". Now transmit (into the primary receiver) your 4-digit passcode. The controller will respond by sending "OK" in CW once. The controller will store the passcode and the main repeater will be enabled.

4.3 Programming the Controller

All programming is done by entering 8-digit DTMF sequences. The first 4 digits are the *passcode* chosen at initialization. The next 2 digits are an *address* or a *function code*. The last 2 digits are the *data* for address or function. To enter programming information, you must key your radio, enter the 8 digits, then unkey. If the controller understands your sequence, it will respond with "OK" in CW. If there is an error in your sequence, but the passcode is good, the controller will respond with "NG". If the controller does not understand your command at all, it will not respond with anything other than a courtesy beep, and then only if the courtesy beep is enabled. If the controller is disabled, and an unrecognized command is entered, no response will be transmitted at all.

Responses to Commands

Response	Meaning
"OK"	Command accepted
"NG"	Command address or data is bad
Courtesy Beep or Nothing	Command / Password not accepted

If you enter an incorrect sequence, you can unkey before all 8 digits are entered, and the sequence will be ignored. If you enter incorrect address or data values, just re-program the location affected with the correct data.

4.4 Programming the Timers

The NHRC-4/MVP Repeater Controller provides several timers which control the operation of your repeater. The *Hang Timer* controls how long the repeater will continue to transmit after a received signal drops. This is often called the repeater's "tail." The tail is useful to eliminate annoying squelch crashes on users' radios. As long as a reply is transmitted before the hang timer expires, the repeater will not drop, which would cause a squelch crash in the users' radios.

The *Timeout Timer* controls the maximum duration of the retransmission of a received signal. It is more of a safety measure to protect the repeater from damage than a way to discourage long-winded users, even though it is often used that way. The NHRC-4/MVP has a separate timeout timer for each port. The timeout timer(s) can be disabled by programming a 0 length.

The *ID Timer* sets the maximum duration between transmissions of the repeater's ID message(s). (Note that the NHRC-4/MVP may transmit an ID message before the timer expires in order to avoid transmitting the ID message while a user is transmitting.)

The timer values are stored as an 8-bit value that allows a range of 0 to 255. Some of the timers require high-resolution timing of short durations, and others require lower resolution timing of longer durations. Therefore, timers values are scaled by either 1/10, 1, or 10 seconds, depending on the application.

NHRC-4/MVP User Guide

Timer Address and Resolution

Timer	Address	Resolution Seconds	Max. Value Seconds
Hang Timer	03	1/10	25.5
Primary Receiver Timeout Timer	04	1	255
Secondary Receiver Timeout Timer	05	1	255
ID Timer	06	10	2550
Fan Timer	07	10	2550

Enter the 4-digit passcode, the timer address, and the timer value, scaled appropriately. For example, to program the Hang Timer for 10 seconds, enter **pppp0264**, where **pppp** is your secret passcode, 02 is the hang timer address, and 64 is the hexadecimal value for 100, which would be 10.0 seconds.

4.5 Programming the CW Messages

CW messages are programmed by storing encoded CW characters into specific addresses in the controller. Use the Morse Code Character Encoding table and the Programming Memory Map to determine the data and address for the CW message characters. For example, to program "DE N1KDO/R" for the CW ID, you would use the following commands:

DTMF Command	Address	Data	Description/Purpose
<i>pppp2609</i>	26	09	D
<i>pppp2702</i>	27	02	E
<i>pppp2800</i>	28	00	space
<i>pppp2905</i>	29	05	N
<i>pppp2A3*</i>	2A	3E	1
<i>pppp2B0D</i>	2B	0D	K
<i>pppp2C09</i>	2C	09	D
<i>pppp2D0#</i>	2D	0F	O
<i>pppp2*29</i>	2E	29	/
<i>pppp2#0A</i>	2F	0A	R
<i>pppp30##</i>	30	FF	End of message marker

The CW ID can store a message of up to 20 characters. Do not exceed 20 characters. Be sure to include the end-of-message character (FF) at the end of each message.

4.6 Programming the Flag Bits

Controller features can be enabled with the use of the Configuration Flag Bits. These bits are encoded in a single byte, which is programmed into the controller at address 01. Multiple flag bits can be selected by adding their hex weights.

For example, to set up a controller with an audio delay on each port, and configure the digital output for fan control, you would add 02, 04, and 10 to produce hex 16, which you would then program into address 01 in the controller with this command:

pppp0131

NHRC-4/MVP User Guide

In addition to programming the flag bits as a group using address 01, the controller supports commands to set or clear these bits individually. Command 60 is used to clear (zero) a specified configuration bit, and command 61 is used to set (one) a specified configuration bit. For example, to set (turn on) bit 3 (to suppress DTMF muting), enter the following command: **pppp6103**. To clear bit 3 and enable the DTMF muting, enter this command: **pppp6003**. Note that the bit *number*, not its hex weight is used for commands 60 and 61.

Configuration Flag Bits

Bit	Hex Weight	Binary Value	Feature
0	01	00000001	secondary port is duplex repeater
1	02	00000010	audio delay on primary receiver
2	04	00000100	audio delay on secondary receiver
3	08	00001000	disable DTMF muting
4	10	00010000	digital output is fan control
5	20	00100000	main receiver has priority over link receiver*
6	40	01000000	drop main transmitter to mute DTMF**
7	80	10000000	drop secondary transmitter to mute DTMF**

Software version \geq 1.4 only.

**Software version \geq 2.2 only

Example Configurations

Flag Bits Value	Features Selected
00	none
01	duplex repeater on secondary port
08	no DTMF muting
10	digital output is fan control
11	duplex repeater on secondary port digital output is fan control
17	duplex repeater on secondary port NHRC-DAD on primary port NHRC-DAD on secondary port digital output is fan control
36	NHRC-DAD on primary port NHRC-DAD on secondary port digital output is fan control main receiver has priority over link receiver*
1F	duplex repeater on secondary port NHRC-DAD on primary port NHRC-DAD on secondary port no DTMF muting digital output is fan control

*Software version \geq 1.4 only.

NHRC-4/MVP User Guide

4.7 Programming the Courtesy Tones

The NHRC-4/MVP uses up to five different courtesy tones to indicate various events:

- primary receiver
- primary receiver, the secondary transmitter enabled
- primary receiver, alert mode
- secondary receiver
- secondary receiver, secondary transmitter enabled

Each tone is individually programmable, and can be unique for that event, programmed to be the same as other events, or programmed empty to be silent.

The NHRC-4/MVP will play the appropriate courtesy tones 500 milliseconds (1/2 second) after a receiver drops. The courtesy tones all consist of four 100 millisecond (1/10 second) segments. Each segment can be no tone, low tone (a "boop", about 440 hertz), or high tone (a "beep", about 880 hertz). If all the segments are programmed as no tone, the courtesy tone will be disabled. The default courtesy tones are shown in the Default Courtesy Tones table.

Default Courtesy Tones

Event	Default Tones	Binary Encoding	Hex Encoding
Primary Receiver	beep none none none	00 00 00 01	01
Primary Receiver Secondary Transmitter Enabled	beep none beep none	00 01 00 01	11
Primary Receiver Secondary Receiver Alert Mode	beep none boop none	00 11 00 01	31
Secondary Receiver	boop none none none	00 00 00 11	03
Secondary Receiver Secondary Transmitter Enabled	boop none boop none	00 11 00 11	33

The courtesy tones are encoded as four pairs of bits, with the first segment encoded as the two least significant bits, and the fourth segment encoded as the 2 most significant bits. Each pair of bits is allowed three possible values to indicate no tone, beep, or boop. The Half Courtesy Tones table shows tones generated for valid 4-bit values and their hex representation. To use this table, first determine the tones for each of the four segments, then find the hex digit that represents the first and second pair of tones. The second pair's digit becomes the first hex digit, and the first pair's digit becomes the second hex digit. For example, to encode a courtesy tone of boop-beep-boop-none, you would find the first pair (boop-beep) in the table as the hex digit D and the second pair (boop-none) in the table as the hex digit 3, so your courtesy tone would be encoded as 3D.

NHRC-4/MVP User Guide

Half Courtesy Tones

Tones	Binary Encoding	Hex Encoding
none none	00 00	0
none beep	01 00	4
none boop	11 00	C
beep none	00 01	1
beep beep	01 01	5
beep boop	11 01	D
boop none	00 11	3
boop beep	01 11	7
boop boop	11 11	F

4.8 *Previewing Stored CW Messages*

Stored CW messages can be previewed with the command *40* followed with the message number you want to preview. The message numbers can be found in the Message Numbers table. For example, to preview the secondary receiver timeout message, send command:

pppp4004

4.9 *Enabling/Disabling the Repeater*

The radio ports can be disabled or enabled by remote control by setting the code for the operational mode in location 00. See the Operational Modes Table for the codes that indicate the mode you want.

Operational Modes

Code	Operational Mode
00	Primary & Secondary off
01	Primary enabled
02	Primary enabled, secondary alert mode
03	Primary enabled, secondary monitor mode
04	Primary enabled, secondary transmit mode

For instance, to disable the repeater, send command:

pppp0000

To enable the repeater on the primary port, send command:

pppp0001

To enable the repeater on the primary port, and select monitor mode for the secondary port, send command:

pppp0003

4.10 Using the NHRC-DAD Digital Audio Delay with the NHRC-4/MVP Repeater Controller.

The NHRC-4/MVP Repeater Controller supports the optional NHRC-DAD digital audio delay board. The NHRC-DAD allows complete muting of received DTMF tones (no leading beep before muting), and suppression of squelch crashes when the received signal drops. The NHRC-DAD has a 128 ms delay on all received audio. The NHRC-4/MVP Repeater Controller supports an NHRC-DAD on both radio ports with a software switch and a dedicated DAD connector for each port. If the DAD is not present, then a jumper must be installed between pins 2 and 3 of the DAD connector (see installation manual). If the DAD is present, then the appropriate configuration flag bit must be set.

4.11 Programming Example

Programming the NHRC-4/MVP Repeater Controller can seem quite complicated at first. This section of the manual is intended as a tutorial to help you learn how to program your controller.

Let's assume we want to program a NHRC-4/MVP Repeater Controller with the following parameters:

CW ID: DE N1LTL/R FN42
Hang Time 7.5 seconds
Timeout timer 120 seconds

First, we will initialize the controller. Install JP3 and apply power to the controller to initialize. After a few seconds, remove JP3. Send DTMF **2381** to set access code to 2381. The controller will send "OK" in CW to indicate the passcode was accepted. Now the controller is initialized, and disabled.

Now we will enable the controller. Send DTMF **23810001** (passcode=2381, address=00, data=01). The controller will send "OK" in CW to indicate the command was successful.

We will now program the CW ID. Looking at the "Programming Memory Map", we can see that the first location for the CW ID is 26. The first letter of the ID is 'D', which we look up in the "Morse Code Character Encoding" table and discover that the encoding for 'D' is 09. Location 26 gets programmed with 09.

Send DTMF **23812609** to program the letter 'D' as the first character of the CW ID. The controller will send "OK" in CW if the command is accepted. If you entered the command correctly, but you don't get the "OK", your DTMF digits may not all be decoding. See the Installation Guide for your controller to readjust the audio level for the DTMF decoder.

The next character is the letter 'E', which is encoded as 02, and will be programmed into the next address, 27. Send DTMF **23812702**.

The next character is the space character, and it will be programmed into address 29. Send DTMF **23812800**. Here are the rest of the sequences to program the rest of the ID message:

NHRC-4/MVP User Guide

23812905 (N in address 29)
23812A3* (1 in address 2A)
23812B12 (L in address 2B)
23812C03 (T in address 2C)
23812D12 (L in address 2D)
23812*29 (/ in address 2E)
23812#0A (R in address 2F)
23813000 (space in address 30)
23813114 (F in address 31)
23813205 (N in address 32)
23813330 (4 in address 33)
2381343C (2 in address 34)
238135FF (EOM in address 35)

After the last character of the CW ID is programmed, the End-of-Message character must be programmed. In this case, the last character of the ID message was programmed into address 34, so the EOM character, which is encoded as FF, goes into address 35:

238135## (EOM into address 35.)

To program the hang timer, we must first determine the address of the hang timer by consulting the Programming Memory Map. The Hang Timer preset is stored in location 03. Next, we need to convert the 7.5 seconds into tenths, which would be 75 tenths of a second. Then the 75 gets converted to hex:

$75 / 16 = 4$ with a remainder of 11, so 75 decimal equals 4B hex.

Now program the hang timer preset by sending **2381034B**.

To program the primary receiver's timer with 120 seconds, we get the address of the primary receiver's timeout timer preset, which is 04, and then convert 120 seconds to hex:

$120 / 16 = 7$ with a remainder of 8, so 120 decimal equals 78 hex.

So we will program location 04 with 78: **23810478**

Any CW message can be played back at any time by "programming" location 40 with the message code you want to play. To play the CW ID, send **23814000**.

5. Appendices

5.1 Tables

5.1.1 Message Contents

Message Number	Contents	Default
0	ID Message	DE NHRC/4
1	Primary Receiver Timeout Message	TO
2	Valid Command Confirm Message	OK
3	Invalid Command Message	NG
4	Secondary Receiver Timeout Message	RB TO

5.1.2 Programming Memory Map

Address	Default Data	Comment
00	01	Enable Flag: 00 Primary & Secondary Off 01 Primary Repeater Enabled 02 Primary Enabled, Secondary Alert Mode 03 Primary Enabled, Secondary Monitor Mode 04 Primary Enabled, Secondary Transmit Mode
01	10	Configuration Flags (see table)
02	00	Digital output control: 00 Off 01 On 02 ½ second On Pulse
03	32	Hang Timer Preset, in tenths
04	1e	Primary Receiver Timeout Timer, in seconds
05	1e	Secondary Receiver Timeout Timer, in seconds
06	36	ID Timer Preset, in 10 seconds
07	00	Fan Timer, in 10 seconds
08	01	Primary Receiver Courtesy Tone
09	11	Primary Receiver Courtesy Tone Secondary Transmitter Enabled
0a	31	Primary Receiver Courtesy Tone Secondary Receiver Alert Mode
0b	03	Secondary Receiver Courtesy Tone
0c	33	Secondary Receiver Courtesy Tone Secondary Transmitter Enabled
0d	00	Reserved
0e	0f	'O' OK Message
0f	0d	'K'
10	ff	EOM
11	ff	EOM
12	ff	EOM
13	ff	EOM
14	05	'N' NG Message
15	0b	'G'
16	ff	EOM
17	ff	EOM
18	ff	EOM
19	ff	EOM
1a	03	'T' TO Message

NHRC-4/MVP User Guide

1b	0f	'O'
1c	ff	EOM
1d	ff	EOM
1e	ff	EOM
1f	ff	EOM
20	0a	'R' TO Message
21	22	'B'
22	00	' '
23	03	'T'
24	0f	'O'
25	ff	EOM
26	09	'D' CW ID starts here
27	02	'E'
28	00	space
29	05	'N'
2a	10	'H'
2b	0a	'R'
2c	15	'C'
2d	29	'/'
2e	30	'4'
2f	ff	EOM
30	ff	EOM
31	ff	EOM
32	ff	EOM
33	ff	EOM
34	ff	EOM
35	ff	EOM
36	ff	EOM
37	ff	EOM
38	ff	EOM
39	ff	EOM
3a	ff	EOM can fit 20 letter id
3b	ff	EOM (safety)
3c	n/a	Passcode Digit 1
3d	n/a	Passcode Digit 2
3e	n/a	Passcode Digit 3
3f	n/a	Passcode Digit 4

**Note that the entire range of 26-3B is available for your CW ID message.
Do not forget to terminate the message with the FF (end-of-message) character.**

NHRC-4/MVP User Guide

5.1.3 Morse Code Character Encoding

Character	Morse Code	Binary Encoding	Hex Value
sk	. . . - . -	01101000	68
ar	. - . - .	00101010	2a
bt	- . . . -	00110001	31
/	- . . - .	00101001	29
0	- - - - -	00111111	3f
1	. - - - -	00111110	3e
2	. . - - -	00111100	3c
3	. . . - -	00111000	38
4 -	00110000	30
5	00100000	20
6	-	00100001	21
7	- - . . .	00100011	23
8	- - - . .	00100111	27
9	- - - - .	00101111	2f
a	. -	00000110	06
b	- . . .	00010001	11
c	- . - .	00010101	15
d	- . .	00001001	09
e	.	00000010	02
f	. . - .	00010100	14
g	- - .	00001011	0b
h	00010000	10
i	. .	00000100	04
j	. - - -	00011110	1e
k	- . -	00001101	0d
l	. - . .	00010010	12
m	- -	00000111	07
n	- .	00000101	05
o	- - -	00001111	0f
p	. - - .	00010110	16
q	- - . -	00011011	1b
r	. - .	00001010	0a
s	. . .	00001000	08
t	-	00000011	03
u	. . -	00001100	0c
v	. . . -	00011000	18
w	. - -	00001110	0e
x	- . . -	00011001	19
y	- . - -	00011101	1d
z	- - . .	00010011	13
space		00000000	00
EOM		11111111	ff

NHRC-4/MVP User Guide

5.2 Terminology and Abbreviations

<u>Term</u>	<u>Description</u>
--------------------	---------------------------

CAS	Carrier Activated Squelch, where receipt of a signal, with or without CTCSS tones will activate the controller.
------------	---

CW	Continuous Wave signals, commonly using "Morse Code." The term "CW" refers to the radio emission type, while "Morse Code" refers to the signaling type used. Typically, they are incorrectly used interchangeably.
-----------	--

Digital Audio Delay (DAD)	Digital Audio Delay (DAD) removes squelch crashes and allows DTMF tones to be fully muted.
----------------------------------	--

DTMF	Also known as "Touch Tone®" codes.
-------------	------------------------------------

ID	Identification
-----------	----------------

PTT	Push-to-Talk
------------	--------------

6. Circuit Board

6.1 Interconnections

Connector	Name	Purpose
J1	“RB DELAY”	Connects power and audio signals for operation of the Digital Audio Delay (NHRC-DAD) board for the secondary radio port.
J2	“DELAY”	Connects power and audio signals for operation of the Digital Audio Delay (NHRC-DAD) board for the primary radio port.
J3	“REMOTE BASE”	Connects the secondary repeater transmit and receive audio, PTT, and CAS signals for the radio to the controller.
J4	“REPEATER”	Connects the primary repeater transmit and receive audio, PTT, CAS, fan control, and power signals to the controller.
JTS64	“JTS64”	Interfaces a Communications Specialists TS-64 to the controller for CTCSS detection.

The following page is a detailed top view of the Revision “B” printed wiring board for the NHRC-4/MVP Repeater Controller.

NHRC-4/MVP User Guide

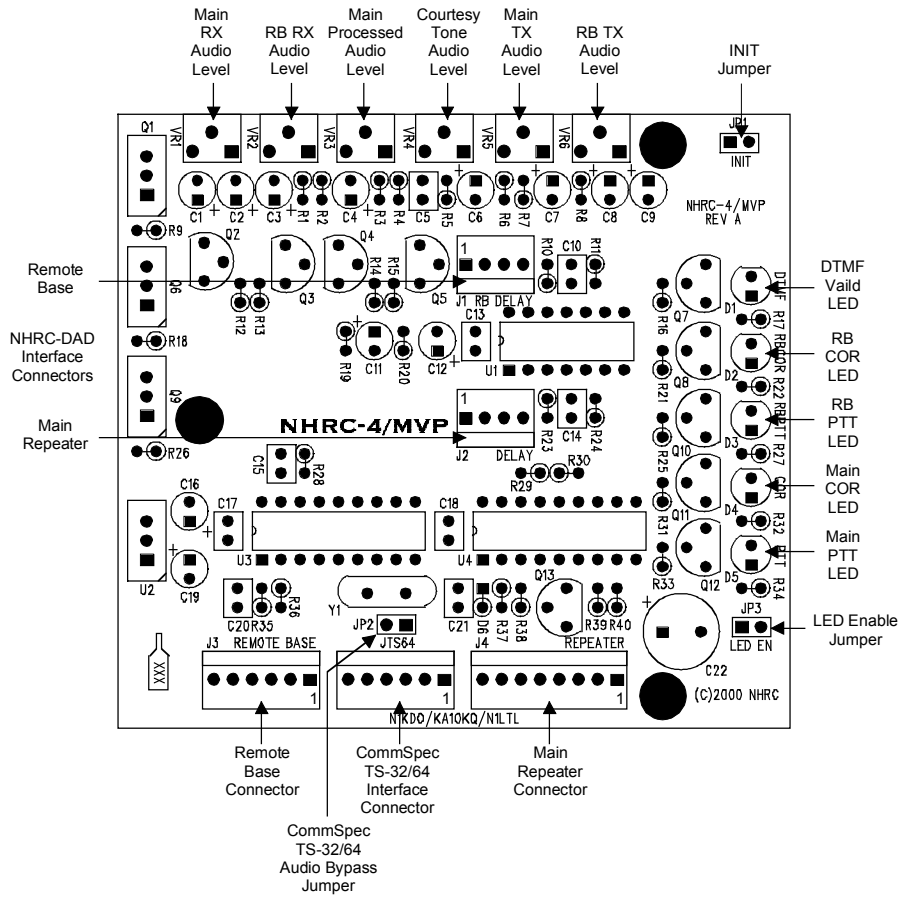

7. Schematics

The following two pages the schematic diagram for the Revision “B” Version of the NHRC-4/MVP Repeater Controller.

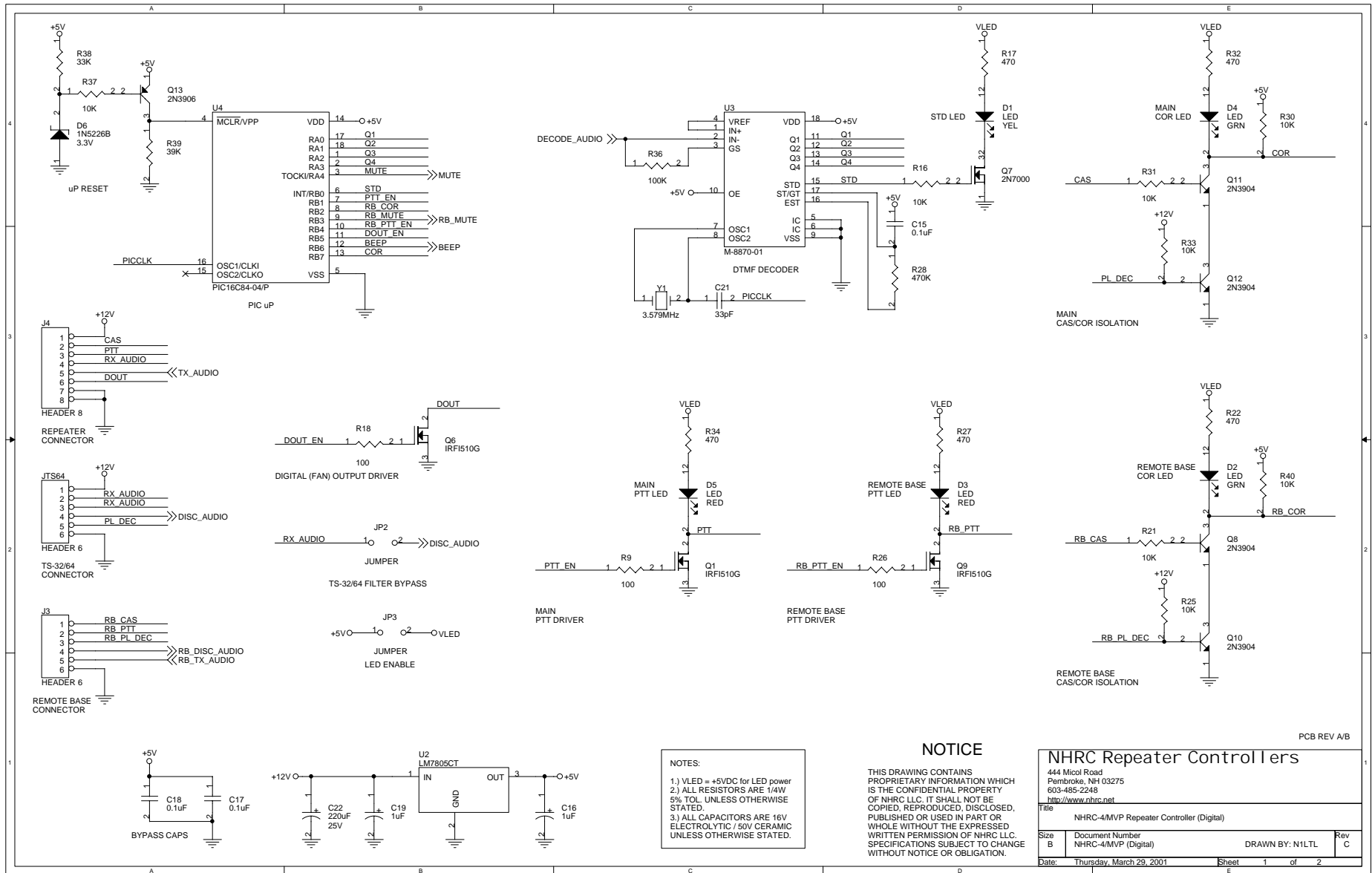

NOTES:
 1.) VLED = +5VDC for LED power
 2.) ALL RESISTORS ARE 1/4W
 5% TOL UNLESS OTHERWISE STATED.
 3.) ALL CAPACITORS ARE 16V ELECTROLYTIC / 50V CERAMIC UNLESS OTHERWISE STATED.

NOTICE

THIS DRAWING CONTAINS PROPRIETARY INFORMATION WHICH IS THE CONFIDENTIAL PROPERTY OF NHRC, LLC. IT SHALL NOT BE COPIED, REPRODUCED, DISCLOSED, PUBLISHED OR USED IN PART OR WHOLE WITHOUT THE EXPRESSED WRITTEN PERMISSION OF NHRC, LLC. SPECIFICATIONS SUBJECT TO CHANGE WITHOUT NOTICE OR OBLIGATION.

PCB REV A/B

NHRC Repeater Controllers			
444 Micol Road Pembroke, NH 03275 603-485-2248 http://www.nhrc.net			
Title NHRC-4/MVP Repeater Controller (Digital)			
Size	Document Number	Rev	
B	NHRC-4/MVP (Digital)	C	
Date:	Thursday, March 29, 2001	Sheet	1 of 2

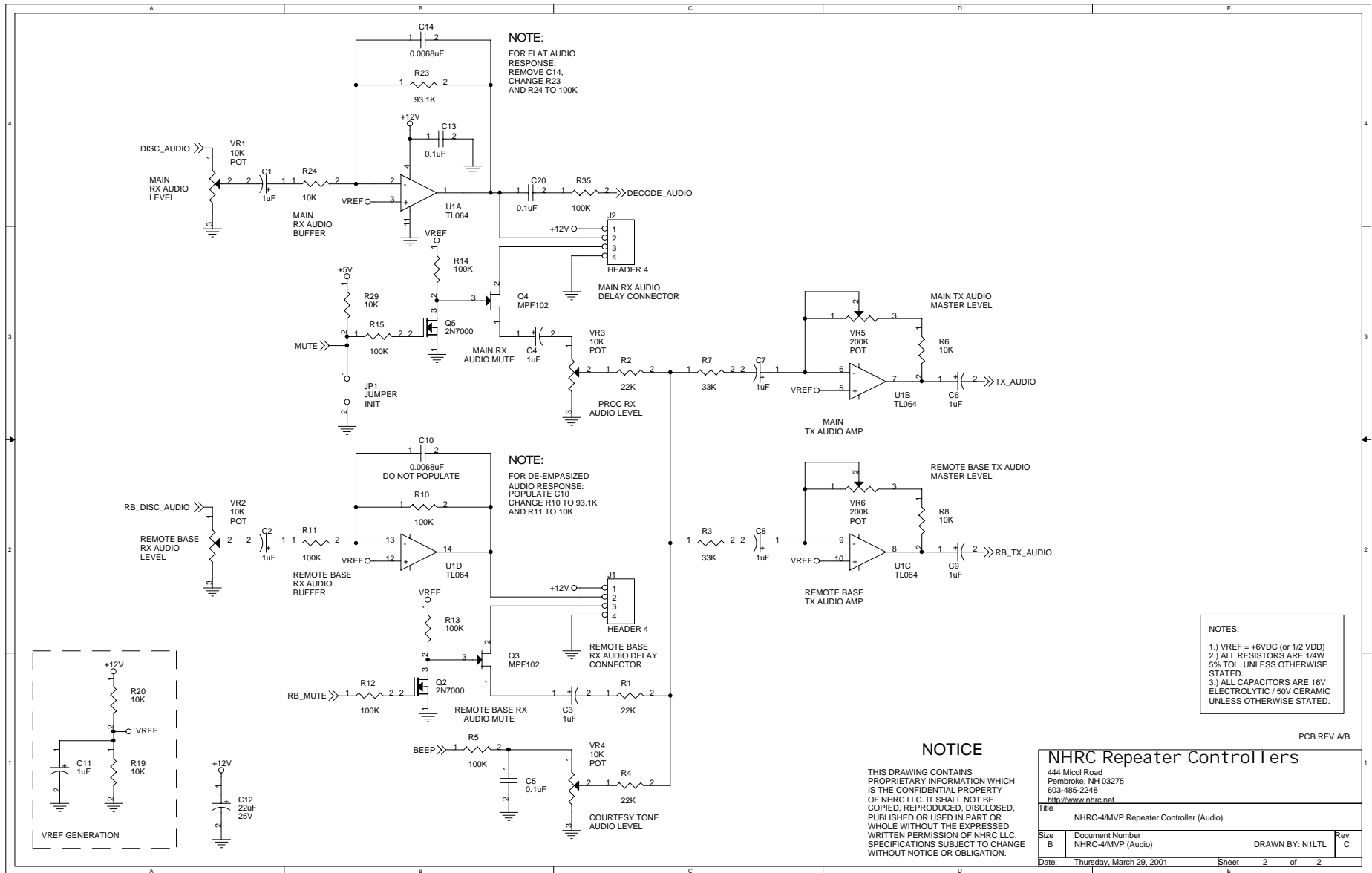

NHRC-4/MVP User Guide

8. Parts List

The following is the bill of materials for revision "B" of the NHRC-4/MVP Repeater Controller.

Item	Qty.	Ref.	Schematic Value		Description	Mfg.	Mfg. P/N	Notes
1	11	C1	1uF		1uF 16V Tantalum Cap	Panasonic	ECS-F1CE105K	or equivalent
		C2	1uF		1uF 16V Tantalum Cap	Panasonic	ECS-F1CE105K	or equivalent
		C3	1uF		1uF 16V Tantalum Cap	Panasonic	ECS-F1CE105K	or equivalent
		C4	1uF		1uF 16V Tantalum Cap	Panasonic	ECS-F1CE105K	or equivalent
		C6	1uF		1uF 16V Tantalum Cap	Panasonic	ECS-F1CE105K	or equivalent
		C7	1uF		1uF 16V Tantalum Cap	Panasonic	ECS-F1CE105K	or equivalent
		C8	1uF		1uF 16V Tantalum Cap	Panasonic	ECS-F1CE105K	or equivalent
		C9	1uF		1uF 16V Tantalum Cap	Panasonic	ECS-F1CE105K	or equivalent
		C11	1uF		1uF 16V Tantalum Cap	Panasonic	ECS-F1CE105K	or equivalent
		C16	1uF		1uF 16V Tantalum Cap	Panasonic	ECS-F1CE105K	or equivalent
		C19	1uF		1uF 16V Tantalum Cap	Panasonic	ECS-F1CE105K	or equivalent
2	6	C5	0.1uF		0.1uF 50V Z5U Ceramic Radial Cap	Panasonic	ECU-S1H104MEA	or equivalent
		C13	0.1uF		0.1uF 50V Z5U Ceramic Radial Cap	Panasonic	ECU-S1H104MEA	or equivalent
		C15	0.1uF		0.1uF 50V Z5U Ceramic Radial Cap	Panasonic	ECU-S1H104MEA	or equivalent
		C17	0.1uF		0.1uF 50V Z5U Ceramic Radial Cap	Panasonic	ECU-S1H104MEA	or equivalent
		C18	0.1uF		0.1uF 50V Z5U Ceramic Radial Cap	Panasonic	ECU-S1H104MEA	or equivalent
		C20	0.1uF		0.1uF 50V Z5U Ceramic Radial Cap	Panasonic	ECU-S1H104MEA	or equivalent
3	2	C14	0.0068uF		0.0068uF 50V X7R Ceramic Radial Cap	Panasonic	ECU-S1H682KBA	or equivalent
		C10	0.0068uF		0.0068uF 50V X7R Ceramic Radial Cap	Panasonic	ECU-S1H682KBA	Do Not Populate
4	1	C12	22uF	25V	22uF 25V Aluminum Radial Electrolytic Cap	Panasonic	ECA-1EM220	or equivalent
5	1	C21	33pF		33pF 100V COG Ceramic Radial Cap	Panasonic	ECU-S2A330JCA	or equivalent
6	1	C22	220uF	25V	220uF 25V Aluminum Radial Electrolytic Cap	Panasonic	ECA-1EM221	or equivalent
7	1	D1	LED	YEL	Yellow T1¼ LED	Lite-On	LTL-4253	or equivalent
8	2	D2	LED	GRN	Green T1¼ LED	Lite-On	LTL-4233	or equivalent
		D4	LED	GRN	Green T1¼ LED	Lite-On	LTL-4233	or equivalent
9	2	D5	LED	RED	Red T1¼ LED	Lite-On	LTL-4203	or equivalent
		D3	LED	RED	Red T1¼ LED	Lite-On	LTL-4203	or equivalent
10	1	D6	1N5226B	3.3V	3.3V 5% 500mW Zener Diode	Diodes Inc.	1N5226B	or equivalent
11	3	JP1	JUMPER		2 Circuit Header, .100" Straight	Molex	22-03-2021	or equivalent
		JP2	JUMPER		2 Circuit Header, .100" Straight	Molex	22-03-2021	or equivalent
		JP3	JUMPER		2 Circuit Header, .100" Straight	Molex	22-03-2021	or equivalent
12	2	JTS64	HEADER 6		6 Circuit Header, .100" Straight w/ lock	Molex	22-23-2061	or equivalent
		J3	HEADER 6		6 Circuit Header, .100" Straight w/ lock	Molex	22-23-2061	or equivalent
13	2	J1	HEADER 4		4 Circuit Header, .100" Straight w/ lock	Molex	22-23-2041	or equivalent
		J2	HEADER 4		4 Circuit Header, .100" Straight w/ lock	Molex	22-23-2041	or equivalent
14	1	J4	HEADER 8		8 Circuit Header, .100" Straight w/ lock	Molex	22-23-2081	or equivalent
15	3	Q1	IRFI510G		N Channel HEXFET	IRF	IRFI510G	or equivalent
		Q6	IRFI510G		N Channel HEXFET	IRF	IRFI510G	or equivalent
		Q9	IRFI510G		N Channel HEXFET	IRF	IRFI510G	or equivalent
16	3	Q2	2N7000		N Channel MOSFET	Fairchild	2N7000	or equivalent
		Q5	2N7000		N Channel MOSFET	Fairchild	2N7000	or equivalent
		Q7	2N7000		N Channel MOSFET	Fairchild	2N7000	or equivalent
17	2	Q4	MPF102		N Channel JFET	Fairchild	MPF102	or equivalent
		Q3	MPF102		N Channel JFET	Fairchild	MPF102	or equivalent
18	4	Q8	2N3904		NPN Transistor	Fairchild	2N3904	or equivalent
		Q10	2N3904		NPN Transistor	Fairchild	2N3904	or equivalent
		Q11	2N3904		NPN Transistor	Fairchild	2N3904	or equivalent
		Q12	2N3904		NPN Transistor	Fairchild	2N3904	or equivalent
19	1	Q13	2N3906		PNP Transistor	Fairchild	2N3906	or equivalent
20	3	R1	22K		22K ¼W 5% Carbon Film Resistor	Yaego	CFR-25JB-22K	or equivalent
		R2	22K		22K ¼W 5% Carbon Film Resistor	Yaego	CFR-25JB-22K	or equivalent
		R4	22K		22K ¼W 5% Carbon Film Resistor	Yaego	CFR-25JB-22K	or equivalent
21	3	R3	33K		33K ¼W 5% Carbon Film Resistor	Yaego	CFR-25JB-33K	or equivalent
		R7	33K		33K ¼W 5% Carbon Film Resistor	Yaego	CFR-25JB-33K	or equivalent
		R38	33K		33K ¼W 5% Carbon Film Resistor	Yaego	CFR-25JB-33K	or equivalent

NHRC-4/MVP User Guide

22	9	R5	100K		100K ¼W 5% Carbon Film Resistor	Yaego	CFR-25JB-100K	or equivalent
		R10	100K		100K ¼W 5% Carbon Film Resistor	Yaego	CFR-25JB-100K	or equivalent
		R11	100K		100K ¼W 5% Carbon Film Resistor	Yaego	CFR-25JB-100K	or equivalent
		R12	100K		100K ¼W 5% Carbon Film Resistor	Yaego	CFR-25JB-100K	or equivalent
		R13	100K		100K ¼W 5% Carbon Film Resistor	Yaego	CFR-25JB-100K	or equivalent
		R14	100K		100K ¼W 5% Carbon Film Resistor	Yaego	CFR-25JB-100K	or equivalent
		R15	100K		100K ¼W 5% Carbon Film Resistor	Yaego	CFR-25JB-100K	or equivalent
		R35	100K		100K ¼W 5% Carbon Film Resistor	Yaego	CFR-25JB-100K	or equivalent
23	14	R6	10K		10K ¼W 5% Carbon Film Resistor	Yaego	CFR-25JB-10K	or equivalent
		R8	10K		10K ¼W 5% Carbon Film Resistor	Yaego	CFR-25JB-10K	or equivalent
		R16	10K		10K ¼W 5% Carbon Film Resistor	Yaego	CFR-25JB-10K	or equivalent
		R19	10K		10K ¼W 5% Carbon Film Resistor	Yaego	CFR-25JB-10K	or equivalent
		R20	10K		10K ¼W 5% Carbon Film Resistor	Yaego	CFR-25JB-10K	or equivalent
		R21	10K		10K ¼W 5% Carbon Film Resistor	Yaego	CFR-25JB-10K	or equivalent
		R24	10K		10K ¼W 5% Carbon Film Resistor	Yaego	CFR-25JB-10K	or equivalent
		R25	10K		10K ¼W 5% Carbon Film Resistor	Yaego	CFR-25JB-10K	or equivalent
		R29	10K		10K ¼W 5% Carbon Film Resistor	Yaego	CFR-25JB-10K	or equivalent
		R30	10K		10K ¼W 5% Carbon Film Resistor	Yaego	CFR-25JB-10K	or equivalent
		R31	10K		10K ¼W 5% Carbon Film Resistor	Yaego	CFR-25JB-10K	or equivalent
		R33	10K		10K ¼W 5% Carbon Film Resistor	Yaego	CFR-25JB-10K	or equivalent
24	3	R9	100		100 ¼W 5% Carbon Film Resistor	Yaego	CFR-25JB-100R	or equivalent
		R18	100		100 ¼W 5% Carbon Film Resistor	Yaego	CFR-25JB-100R	or equivalent
		R26	100		100 ¼W 5% Carbon Film Resistor	Yaego	CFR-25JB-100R	or equivalent
25	1	R23	93.1K		93.1K ¼W 5% Metal Film Resistor	Yaego	MFR-25FBF-93K1	or equivalent
26	5	R17	470		470 ¼W 5% Carbon Film Resistor	Yaego	CFR-25JB-470R	or equivalent
		R22	470		470 ¼W 5% Carbon Film Resistor	Yaego	CFR-25JB-470R	or equivalent
		R27	470		470 ¼W 5% Carbon Film Resistor	Yaego	CFR-25JB-470R	or equivalent
		R32	470		470 ¼W 5% Carbon Film Resistor	Yaego	CFR-25JB-470R	or equivalent
		R34	470		470 ¼W 5% Carbon Film Resistor	Yaego	CFR-25JB-470R	or equivalent
27	1	R28	470K		470K ¼W 5% Carbon Film Resistor	Yaego	CFR-25JB-470K	or equivalent
28	1	R39	39K		39K ¼W 5% Carbon Film Resistor	Yaego	CFR-25JB-39K	or equivalent
29	1	U1	TL064		Quad Op-Amp	TI	TL064CN	see note 1
30	1	U2	LM7805CT		5V 1.0A Voltage Regulator	Nat'l Semi	LM340T-5.0	or equivalent
31	1	U3	M-8870-01		DTMF Decoder	Teltone	M-8870-01	see note 1
32	1	U4	PIC16C84-04/P		PIC Microcontroller (Blank)	Microchip	PIC16F84-04I/P	see note 1
33	4	VR1	10K	POT	10K 6mm Carbon Trimpot	Panasonic	EVN-D2AA03B14	or equivalent
		VR2	10K	POT	10K 6mm Carbon Trimpot	Panasonic	EVN-D2AA03B14	or equivalent
		VR3	10K	POT	10K 6mm Carbon Trimpot	Panasonic	EVN-D2AA03B14	or equivalent
		VR4	10K	POT	10K 6mm Carbon Trimpot	Panasonic	EVN-D2AA03B14	or equivalent
34	2	VR5	200K	POT	200K 6mm Carbon Trimpot	Panasonic	EVN-D2AA03B25	or equivalent
		VR6	200K	POT	200K 6mm Carbon Trimpot	Panasonic	EVN-D2AA03B25	or equivalent
35	1	Y1	3.579MHz		3.579545MHz Crystal	ECS	ECS-35-17-4	or equivalent
Additional Items								
36	1				NHRC-4/MVP PCB REV B	NHRC	NHRC-4/MVP PCB REV B	
37	2				18 Pin DIP Socket	Mill-Max	110-99-318-41-001	use at U3/U4
38	1				14 Pin DIP Socket	Mill-Max	110-99-314-41-001	use at U1

Notes:

1. Use sockets for U1, U3 and U4.

NHRC LLC Limited Warranty

NHRC LLC warrants that its assembled and tested products will be free from defects in materials and workmanship for a period of NINETY DAYS from the date of shipment. During this period, NHRC LLC will repair or replace, at our option, any of our products that fail as a result of defects in materials or workmanship. NHRC LLC's liability will be limited to parts, labor, and return shipping for this period.

NHRC LLC warrants that its kit products will contain components that are free from defects in materials and workmanship for a period of THIRTY DAYS from the date of shipment. During this period, NHRC will replace any of the components in a kit ONCE. Subsequent replacement of any component any subsequent times is completely at the discretion of NHRC LLC, and may require the complete return of the kit.

In no case will NHRC LLC be liable for products damaged by improper wiring (including, but not limited to, over-voltage or application of reverse polarity), physical damage resulting from misuse and/or abuse of the product, neglect, or acts of God (lightning, floods, etc.).

Unauthorized modification of a NHRC product will void the warranty on the modified product.

In no case will NHRC LLC be liable for any direct, consequential, or incidental loss or damage resulting from the use or inability to use any of its products.

Some states or countries do not allow the limitation of incidental or consequential damages, so the paragraph above may not apply to you.

This warranty applies only to the original purchaser of the product; proof of purchase must be presented to receive warranty service.

NHRC
REPEATER CONTROLLERS