

linear modulation technology

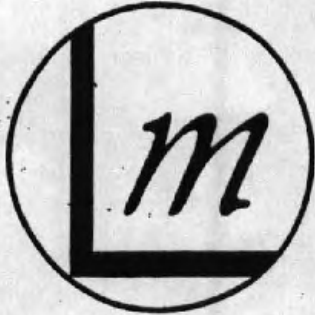

SERVICE MANUAL

**FOR THE LM REPEATER SITE (BASE STATION)
(25 WATT AND 100 WATT)**

Linear Modulation Mobile Radio System
Advanced Digital Network Trunking
Part Nos. LMC30051 and LMC30052

**Securicor Radiocomms Limited
Cross Keys House
Westfield Industrial Estate
Midsomer Norton
Bath BA3 4BS England
Telephone +44 (0)1761 416035
Fax +44 (0)1761 412801**

Publication Reference SM/02/1.2
December 1995
Printed in England



- ◆ DO NOT use this equipment near unshielded electrical blasting caps or in an explosive atmosphere.
- ◆ The 100W PA unit (LMC30052) uses power transistors that contain beryllium oxide, which is extremely toxic. The power transistors are identified as TR6 041806-2 and TR7 015106-2.
In the unlikely event of coming into contact with beryllium oxide, wash thoroughly with soap and water, if skin is broken obtain medical attention. If eye-contact, wash for 15 minutes with running water including under the eyelids, and seek medical attention. If ingested or inhaled, seek medical attention immediately.

Repairs, Modifications and Maintenance

- ◆ If any operational difficulties arise while using this product, report them to authorized service personnel as soon as possible.
- ◆ This system contains no user serviceable parts. Unauthorized adjustments or modifications will void the warranty and may lead to emissions outside FCC limits.
- ◆ DO NOT connect an external power amplifier to this equipment.



1. LMC30051/LMC30052 Specifications

The following specifications are intended for testing and servicing the Repeater. Specifications are subject to change without notice.

1.1 General

Operating Mode	Full Duplex	
Frequency Range		
Receive	221-222 MHz	
Transmit	220-221 MHz	
Transmit/Receive Separation	1 MHz	
Channel Spacing	5 kHz	
Channel Increment	2.5 kHz	
Supply Voltage	240 V AC	110 V AC
Current Drain (typical, std test signal)		
Transmit 25 W	0.34 A	0.70 A
Transmit 100 W	0.71 A	1.52 A
Receive	0.19 A	0.33 A
Temperature Range		
Operational	-30 °C to +55 °C	
Storage	-40 °C to +85 °C	
Dimensions		
Width	482 mm	(19.0")
Depth	360 mm	(14.2")
Height	177 mm	(1.95")
Weight	12.02 kg	(26.45lb)
Approvals	FCC Part 15, 90	
Audio Frequency Response	±0.75 dB, 300 Hz to 3 kHz	

1.2 Receiver

Sensitivity	
20dB SINAD	< -107 dBm, typically -112 dBm
12dB SINAD	< -115 dBm
Selectivity	> 50 dB at 5 kHz
Intermodulation	65 dB
Spurious and Image Rejection	70 dB
Distortion	3%
RF Input Impedance	50 Ω , unbalanced to ground, maximum VSWR 2:1
Frequency Stability	± 0.1 ppm



1.3 Transmitter

RF Output Power, Nominal (Peak Envelope Power)	25 W	100 W
RF Output Power, Minimum (Peak Envelope Power)	1 W	4 W
Spurious & Harmonic Emissions (≤ 250 kHz from Channel centre. Reference largest in channel signal in 100 Hz bandwidth)	-61 dBc	-67 dBc
Spurious & Harmonic Emissions (≥ 250 kHz from Channel centre. Reference largest in channel signal in 10 kHz bandwidth)	-69 dBc	-75 dBc
Audio Modulation	4K00J3E	
RF Load Impedance	50 Ω , unbalanced to ground	
Frequency Stability	± 0.1 ppm	

1.4 Frequency Standard

Output Level	3 ± 2 dBm
Input Level	0 ± 10 dBm
Frequency	10.000 MHz
Frequency Stability	± 0.1 ppm



Contents

1. LMC30051/LMC30052 Specifications.....	1-1
1.1 General	1-1
1.2 Receiver.....	1-1
1.3 Transmitter.....	1-2
1.4 Frequency Standard	1-2
2. Introduction	2-1
2.1 Scope of Manual.....	2-1
2.2 Definitions	2-1
2.3 Reference Documents	2-1
2.4 Related Documents.....	2-2
2.5 Equipment Description	2-2
2.5.1 Channel Shelf.....	2-2
2.5.2 Frequency Standard	2-3
2.5.3 Combining System.....	2-3
2.5.4 System Control Interface	2-4
2.5.5 System Control and Monitoring.....	2-4
2.5.6 System Options.....	2-4
2.6 On-Site System Testing.....	2-5
3. Linear Modulation	3-1
3.1 Definition	3-1
3.2 LM Methods.....	3-1
3.2.1 Transparent Tone In Band.....	3-1
3.2.2 Feed Forward Signal Regeneration.....	3-1
3.2.3 Cartesian Loop.....	3-2
3.3 Transmission Process	3-2
3.4 Cartesian Loop Linearisation of the Transmitter	3-4
3.5 Reception Process	3-5
4. Advanced Digital Network Trunking (ADNT)	4-1
4.1 Control Channel	4-1
4.2 Call Setup and Clear Down.....	4-1
5. Controls, Indicators and Displays	5-1
5.1 System Control Interface	5-1
5.1.1 The Keypad	5-2
5.1.2 On-Site Functions.....	5-2
5.2 Power	5-4
5.3 PA LED	5-4
5.4 TCC LEDs.....	5-4
5.4.1 PTT	5-5
5.4.2 CW LOCK (Code Word Lock).....	5-5
5.4.3 TALK.....	5-5
5.4.4 IN SERVICE.....	5-5
5.4.5 SQUELCH.....	5-5
5.5 TCC Display.....	5-5
5.5.1 Power Up Sequence	5-5
5.5.2 Failure Codes.....	5-6



5.5.3 Normal Operation (Control Channel).....	5-6
5.5.4 Normal Operation (Traffic Channel).....	5-6
5.6 TCC Internal Controls.....	5-7
5.6.1 SIO Bus Address.....	5-7
5.6.2 Channel Number.....	5-7
5.6.3 FFSK Output Level.....	5-8
5.7 TCC Front Panel Controls.....	5-8
5.7.1 Squelch Level.....	5-8
5.7.2 FFSR Threshold Level.....	5-9
5.7.3 Pilot Pumping.....	5-9
5.8 Frequency Standard.....	5-9
5.8.1 Internal/External Select.....	5-9
6. Installation.....	6-1
6.1 Performance Tests.....	6-1
6.2 Power Supply.....	6-1
6.3 Location.....	6-1
6.4 System Control Interface.....	6-2
6.4.1 System Control Terminal (Syscon) or Central Computer.....	6-2
6.5 Channel Setup.....	6-3
6.6 Repeater Rack.....	6-3
6.6.1 Frequency Standard.....	6-4
6.6.2 Channel Shelves.....	6-5
6.6.3 Earth Connection.....	6-6
6.7 Combining Rack (optional).....	6-6
6.7.1 Cavity Alignment.....	6-6
6.7.2 Receiver Connections.....	6-6
6.7.3 Transmitter Connections.....	6-7
6.7.4 Antenna Connection.....	6-7
6.7.5 Earth Connection.....	6-7
7. Operation.....	7-1
7.1 Power Up.....	7-1
7.2 Control Channel Selection.....	7-1
7.3 Squelch Setting.....	7-2
7.4 During a Call.....	7-2
8. Circuit Description.....	8-1
8.1 Receiver.....	8-1
8.2 Exciter and Power Amplifier.....	8-2
8.3 Trunking Channel Controller.....	8-4
8.4 Power Supply Unit.....	8-5
8.5 Frequency Standard.....	8-5
8.6 System Control Interface.....	8-5
8.6.1 Main Board.....	8-6
8.6.2 RAM Banks.....	8-6
8.7 The I ² C Bus.....	8-7
8.7.1 Commands.....	8-7
8.7.2 Responses.....	8-7
9. Commissioning.....	9-1
9.1 Range.....	9-1
9.2 Transmission Losses.....	9-1
9.3 Receiver Losses.....	9-1
9.4 Reciprocity.....	9-2
10. Simplified On-Site Testing.....	10-1
10.1 Test Equipment.....	10-1



10.2 Frequency Reference	10-1
10.3 Receiver Sensitivity Tests	10-2
10.3.1 Setting up the Equipment.....	10-2
10.3.2 Measuring Receiver Sensitivity	10-2
10.3.3 Receiver Testing via Splitter/Amplifier.....	10-6
10.3.4 Returning Equipment to Operation.....	10-6
10.4 Transmitter Tests	10-7
10.4.1 Transmitter Testing, Direct Connection	10-7
10.4.2 Transmitter Testing, Connection via Transmitter Combiner.....	10-8
10.4.3 Returning Equipment to Operation.....	10-9
10.4.4 Carrier Wave Identification (CWID)	10-9
11. Comprehensive On-Site Testing	11-1
11.1 Test Equipment	11-1
11.2 Frequency Standard	11-1
11.3 Test Modes	11-1
11.3.1 Transmit Preamble.....	11-2
11.3.2 Transmitter Test Modes.....	11-2
11.3.3 Transmitter Power Adjust	11-2
11.4 Receiver Tests	11-2
11.4.1 Connections.....	11-2
11.4.2 Ultimate SINAD Test.....	11-3
11.4.3 Sensitivity Test.....	11-3
11.5 Transmitter Tests	11-3
11.5.1 Connections.....	11-3
11.5.2 Spectrum Analyzer Set-up	11-3
11.5.3 Stability: Pilot Only Test.....	11-4
11.5.4 Linearity: Two Tone Test	11-4
11.5.5 Image Suppression: One Tone Test.....	11-5
11.5.6 External Signal Test.....	11-6
11.5.7 Adjusting Transmit Power	11-6
12. Channel Frequencies.....	12-1
13. Base Station 5-Channel 25/100 W	13-1
14. System Control Interface	14-1
15. 10 MHz Frequency Standard	15-1
16. Channel Shelf 25 W / 100 W.....	16-1
17. Power Amplifier 25 W.....	17-1
18. Power Amplifier 100 W.....	18-1
19. Trunking Channel Controller	19-1
20. Channel Receiver Unit.....	20-1
21. Channel Exciter Unit.....	21-1
22. 200W Power Supply Unit	22-1
23. 400W Power Supply Unit	23-1



Amendment Schedule

Amendments to this manual will be issued to incorporate changes or detail additional information. Amended pages will be identified by the amendment date and number shown at the foot of the page. Record incorporation of amendments to this manual on this page.

If a new issue of this manual is made all amendments will be incorporated.

Date	Amdt. No.	Date Incorporated	Reason for Change

If you find any errors or omissions in this manual, or you have any suggestions for improvements please write to the address shown on the front of this manual.



2. Introduction

2.1 Scope of Manual

This service manual contains installation, operation and service information for the Linear Modulation Technology Limited Repeater Site. This manual applies to both 25 W (LMC30051) and 100 W (LMC30052) equipment.

2.2 Definitions

ADNT	Advance Digital Network Trunking
AGC	Automatic Gain Control
CCITT	Consultatif Committee Internationale Telephones et Telecommunications (now ITU)
CTU	Control and Trunking Unit
DSP	Digital Signal Processor
DTMF	Dual Tone Multiple Frequency
FFSR	Feed Forward Signal Regeneration
FPU	Front Panel Unit
I ² C	Inter-Integrated Circuit (bus).
PABX	Private Automatic Branch eXchange
PSTN	Public Switched Telephone Network
PTT	Press To Talk
RFU	Radio Frequency Unit
SCL	Serial clock
SDA	Serial data
SDM1	Short Data Message Type 1
SDM2	Short Data Message Type 2
SINAD	Signal/Noise and Distortion
SPU	Signal Processing Unit
TCC	Trunking Channel Controller
TTIB	Transparent Tone In Band
VSWR	Voltage Standing Wave Ratio

2.3 Reference Documents

- MPT1327 A Signalling Standard for Trunked Private and Land Mobile Radio Systems (Radiocommunications Agency (UK)).
- MPT1343 System Interface Specification for Radio Units to be Used with Commercial Trunked Networks Operating in Band III and Sub-Bands 1 and 2. (Radiocommunications Agency (UK)).
- MPT1376 Co-existence Standard for Transmitters and Receivers Operating in 5 kHz Channels (Radiocommunications Agency (UK)).



2.4 Related Documents

- ◆ LMM 3115 Mobile Service Manual (SM/01/2.0)
- ◆ SYSCON Manual (TL/12/1.4)
- ◆ Trunking Technical Reference Manual (TL/13/1.1)

2.5 Equipment Description

The Repeater Site is part of the LM trunked radio system which allows mobiles to communicate using 5 kHz channel assignments. A modulation scheme called Linear Modulation is used, which is spectrally efficient and provides a medium particularly suited to the varying propagation effects (e.g. multipath and Doppler) encountered in a typical mobile environment. The system is designed for speech and data use, with data rates of 14,400 bits per second achievable.

The repeater employs digital signalling and provides trunked operation using the Advanced Digital Network Trunking (ADNT) system, based on the UK specification MPT1327. The unit provides features such as Status Calls, Call Queueing, Priority Calls, Data Calls, Emergency Calls, Group Calls, Individual Calls and Telephone Connection.

The system is completely modular, allowing easy expansion from a simple local system, to a large multi-channel, multi-site network. Channels may be added or removed with the system 'live', and the system will automatically re-configure itself to use the new equipment. Up to 24 channels can be accommodated on a single site. Single site installations can be upgraded to multi-site by adding a Central Control Computer. Up to 10 sites can be linked in this way.

The system is fully automatic, and can operate unattended. It can be remotely controlled using a Control Terminal connected via a modem and telephone line. Refer to the SYSCON Manual (TL/12/1.4) for details of operation of the Control Terminal.

The Repeater Site consists of, as a minimum, the following equipment mounted in standard 19 inch cabinets:

- ◆ Up to 24 Channel Shelves
- ◆ Frequency Standard (a minimum of one per 5-channel rack)
- ◆ System Control Interface (SCI)
- ◆ Combining and Duplexing System.

2.5.1 Channel Shelf

A channel shelf consists of a two-frequency duplex radio channel which provides base to mobile communication and a talkthrough connection for mobile to mobile, along with trunking signalling and control. It operates on the 200 channels in the 220 MHz band (220-221 MHz repeater transmit, 221-222 MHz repeater receive). It is a 4U high unit, consisting of five modules which can be removed independently from the shelf.

**◆ Receiver Module**

Receives radio frequency signals from LM mobiles, demodulates the resulting Transparent Tone In Band (TTIB) signals, corrects for fading and Doppler effects using Feed Forward Signal Regeneration (FFSR), and passes the recovered audio signal to the TCC. It is controlled by the TCC via an I²C bus.

◆ Trunking Channel Controller

Responsible for controlling the radio modules, generating and interpreting trunking signalling, and routing audio signals. It also forms part of the distributed processing for the trunking system. All the TCCs in a site are connected together, and to the System Control Interface by a high speed Serial I/O bus.

◆ Exciter Module

Takes an audio output from the TCC, produces from it a baseband TTIB signal, and directly converts it up to the transmit frequency for driving the PA. It uses a feedback signal from the PA to linearise the amplifier using a technique known as Cartesian Loop Linearisation. The whole operation of the exciter is controlled by the TCC via an I²C bus.

◆ Power Amplifier

Takes the RF signal from the Exciter and amplifies it to a level suitable for radiation from an antenna. A feedback loop to the Exciter makes the transmitter highly linear, to meet statutory near-channel radiation specifications. It is available in 25 W and 100 W Peak Envelope Power (PEP) ratings.

◆ Power Supply Unit

This is a switched-mode power supply which converts AC supply to DC. The 100 W power amplifier requires 28 V and 14 V DC. All the other modules require 14 V DC. It is available in two power ratings. The 200 W version is for use with the 25 W PA, and the 400 W version is for use with the 100 W PA.

2.5.2 Frequency Standard

This is a precision frequency standard containing an ovened oscillator, which generates a highly stable (0.1 ppm) 10 MHz frequency reference from which all the RF local oscillators are derived. All the local oscillators within the Receiver and Exciter modules are locked to this reference. The unit provides 11 outputs so that it can drive 5 channels, and have a spare output for connection to test equipment, or chaining to other racks. It also has an input allowing it to be locked to an external reference for improved stability or chaining.

2.5.3 Combining System

The Combining System combines together the outputs of all the channel power amplifiers providing transmitter/transmitter isolation to reduce intermodulation effects. It also provides transmitter/receiver isolation (duplexing) to prevent blocking of the receivers. It comprises a Circulator and Tuned Cavity for each transmit channel, a Transmit Duplex Filter, a Receive Duplex Filter, and a Receive Signal Amplifier (RSA) which



includes a band-pass filter. The combining system is mounted in a separate rack.

Note: In order to meet different operational requirements, the combining system may differ from that described above.

2.5.4 System Control Interface

The SCI controls the authorization of users onto the system, the collection of billing data, control of system parameters, and general system monitoring. It is usually controlled using SYSCON. Refer to the SYSCON Manual (TL/12/1.4) and Trunking Technical Reference Manual (TL/13/1.1) for details of the operation of the SCI.

2.5.5 System Control and Monitoring

The system can be monitored remotely, or locally using the SYSCON program. SYSCON can monitor multiple sites (up to 10), records failures and can be used to generate automatic alarms.

2.5.6 System Options

A single repeater rack can be supplied with between 1 and 5 channel shelves. A site can have up to 24 channels, so a large system will require several racks. Each rack needs its own frequency standard, and these must be locked together using the external input connector.

The PA modules can be supplied as either 25 W or 100 W units, depending on the licence conditions, coverage required and the reciprocity of the system. When calculating the radiated power from a site, the antenna gain, feed cable, combiner unit and filter losses should be taken into account. Because of the insertion losses through the combining equipment, it is likely that 100 W units will be used in most systems.

Other units include:

- ◆ **Central Computer (CC)**
Required to link together and control the various sites for multi-site operation. Also provides connection to telephone services.
- ◆ **Single-Site Interconnection Controller (SSIC)**
For telephone interconnection on a single site network where there is no CC available.
- ◆ **PCM Switch**
Needed for routing the audio in multi-site and telephone interconnect installations.
- ◆ **Line Interface Unit (LIFU)**
May be required between the channel shelf and the switch, to provide line level matching, companding and isolation.



2.6 On-Site System Testing

On-site system testing is described in Sections 10 and 11.

Section 10 is for **simplified on site testing** and tests receiver SINAD, transmitter output power and general operation. An HP 8920B test set or similar is used for this test.

Section 11 is for **full on site testing** and is a more comprehensive test including tests for output purity.

Normally the tests in section 10 will be used to commission a site but if problems have been, or are likely to be encountered concerning sideband emissions, noise, co-siting etc. the tests in section 11 should be performed. This test requires two signal generators and a spectrum analyser. The test can also be used in the workshop to check equipment before putting it into the field.



3. Linear Modulation

3.1 Definition

Linear Modulation (LM) is a Radio Frequency (RF) transmission technique suitable for the transfer of speech and high speed data over a radio bearer which is extremely narrow band. In this context narrow band is a 5 kHz bandwidth radio channel.

The speech quality over a 5 kHz channel using LM techniques is comparable to that achieved from a 12.5 kHz channel using Frequency Modulation, and can be better under some circumstances. The available bandwidth supports data transmission rates up to at least 14,400 bits per second (V32bis). The system has good adjacent and co-channel performance exceeding that specified for narrow band systems both by the DTI in the United Kingdom and the FCC in the United States.

Note also that for Linear Modulation systems, transmitted power is related to the modulation level. This is unlike FM systems, which transmit a constant envelope. This fact provides a lower power consumption for LM equipment when compared to AM or FM equipment which is particularly important for the sizing of standby power systems and for hand-portable units.

3.2 LM Methods

Linear Modulation uses a number of methods to achieve this high quality performance. These are the use of a **Transparent Tone In Band (TTIB)** reference signal, **Feed Forward Signal Regeneration (FFSR)** for signal recovery and **Cartesian loop** linearisation of the RF transmitter.

3.2.1 Transparent Tone In Band

A calibrated tone is inserted into the audio band. None of the wanted audio is lost as a gap is specially created for it. The pilot tone is used in the receiver to remove path distortions from the audio.

3.2.2 Feed Forward Signal Regeneration

In the receiver, FFSR is used to correct for Doppler shift and multipath distortions which affect signals when transmitted in mobile environments. The distortions on the path are calculated from the received pilot tone, and the whole audio band is then corrected for these distortions.

TTIB and FFSR together provide excellent resistance to mobile distortion effects and provide a transmission environment suited to carrying very high quality speech and high speed data.

3.2.3 Cartesian Loop

The Cartesian loop provides a linear transmitter which does not distort the signal and minimises radiation into adjacent and near channels.

3.3 Transmission Process

The splitting process and the tone insertion occurs in a Digital Signal Processor (DSP). The DSP can perform manipulations to the signal in the digital domain which are not possible in the analog domain — for example, the use of negative frequencies.

The audio signal from the microphone is first passed through an analog to digital (A to D) converter and then input to the DSP. This digital audio signal, which has an audio spectrum between 300 Hz and 3000 Hz, undergoes TTIB processing. This splits the band at 1650 Hz to give an upper and lower sub-band. The two sub-bands are then shifted apart from each other in frequency to form a gap 600 Hz wide.

A pilot tone is inserted between between the two sub-bands. The resulting audio signal is used to modulate the Cartesian Loop transmitter.

Internally the DSP represents the audio signal not simply as the digital stream derived from the A to D converter but as a complex quantity in Cartesian form (e.g. the instantaneous value at any point in time is not defined by amplitude and phase but by a Cartesian co-ordinate value using *I* and *Q* axes, which represent the instantaneous amplitude and phase).

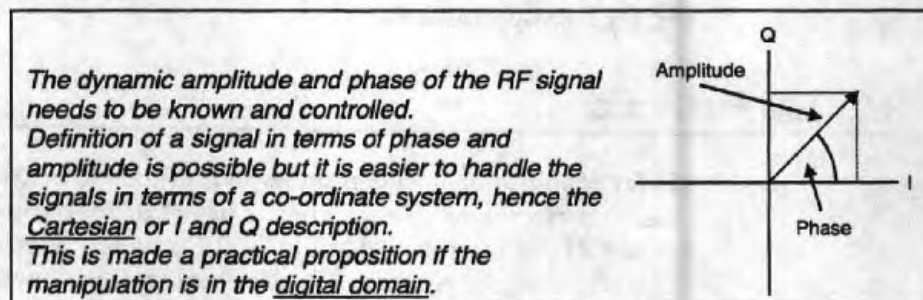

Figure 3-1

It also takes the all positive 300 to 3000 Hz input audio signal, and places it symmetrically about a nominal DC (0 Hz) point. The audio range is now -1500 Hz to +1500 Hz.

The manipulation from the input audio signal to two audio sub-bands is shown in Figure 3-2.

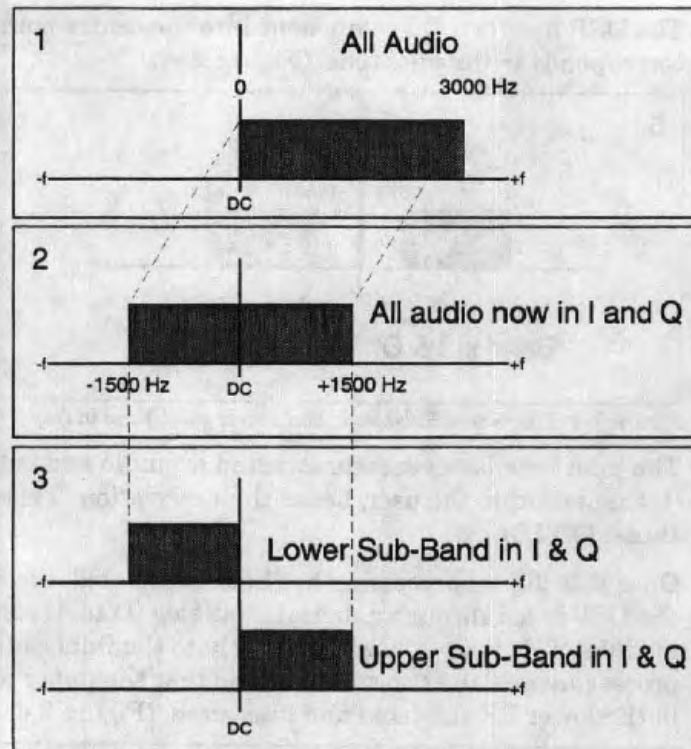

Figure 3-2 Frequency Shift Baseband Audio to give Signal in I and Q and Split into Upper and Lower Sub-bands

Having placed the audio signal around a defined point (0 Hz), the DSP now splits the negative portion away from the positive portion as two sub-bands, the lower sub-band holding the information derived from the microphone in the 0 (actually 300) Hz to 1650 Hz spectrum the upper sub-band containing the remaining 1650 Hz to 3000 Hz information.

The two sub-bands are then 'moved apart' leaving a 'gap' between the upper and lower sub-bands (Figure 3-3).

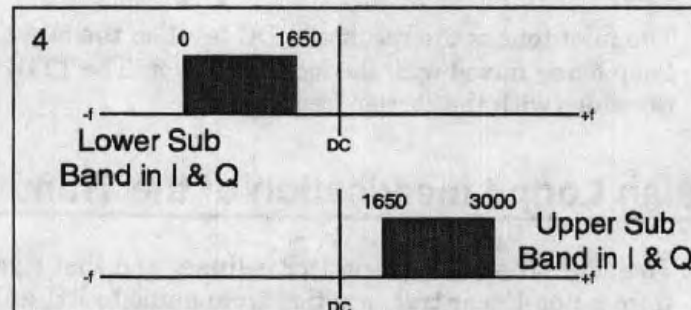

Figure 3-3 Shift Sub-bands in Frequency to make Gap



The DSP inserts a DC component into the centre point of the gap, which corresponds to the pilot tone. (Figure 3-4).

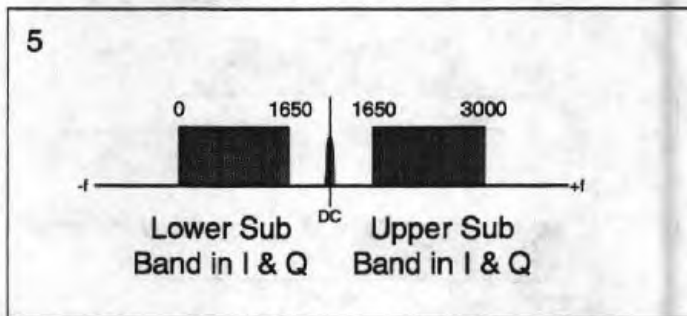

Figure 3-4 Recombine Sub-bands and Insert Pilot Tone in Gap

The pilot tone is never reconstructed as audio and is therefore inaudible (transparent) to the user, hence the description: **Transparent Tone In Band (TTIB)**.

Once this digital processing has been completed, the digital audio from the DSP is fed through a digital to analog (D to A) converter into the modulator. It is up-converted directly to the final radio frequency. The process inverts the two sub-bands so that the upper audio band appears in the lower RF sub-band and *vice versa*. (Figure 3-5).

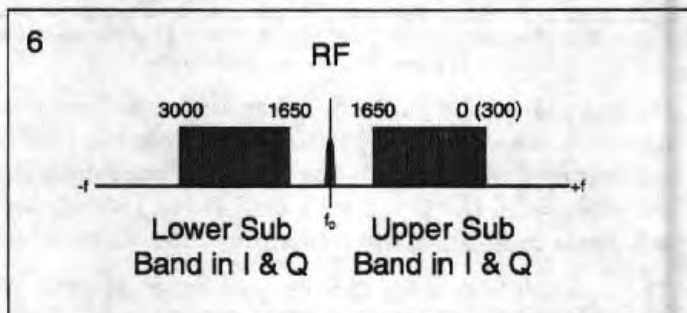

Figure 3-5 Up-convert to RF to Give Transmitted Signal

The pilot tone is the result of a DC level on the input to the Cartesian Loop being mixed with the local oscillator. The TTIB tone therefore coincides with the carrier frequency.

3.4 Cartesian Loop Linearisation of the Transmitter

To ensure that the transmitter is linear and that signals do not suffer from a non-linear transposition from audio to RF, a linearisation technique is applied to the transmitter. This is achieved by the use of a **Cartesian Loop Transmitter (CLT)**.

The **Cartesian Loop Transmitter (CLT)** uses an RF directional coupler to provide a sample of the outgoing transmission. This is fed back to an RF demodulator which produces two outputs in Cartesian form — *I* and *Q* (hence Cartesian Loop feedback). These are compared with the values of the *I* and *Q* inputs to the modulator and any variation compensated for. This feedback regime produces a very linear RF transmitter with high efficiency.

3.5 Reception Process

Any transmitted signal, whatever the transmission technique, is distorted by the radio path in terms of amplitude, frequency and phase (Figure 3-6) by a number of factors including Doppler and multi-path (Rayleigh fading) effects.

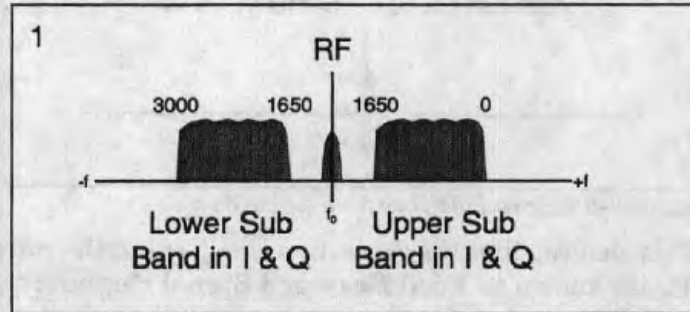

Figure 3-6 Received Signal with Path Distortions at RF

In an LM transmission this distortion affects both the transmitted audio and the pilot tone.

The receiver is a conventional 2-stage superheterodyne receiver which presents a version of the received signal at an IF of 12.5 kHz to the DSP via an A to D converter. The DSP mixes this signal down to I and Q about DC. (Figure 3-7).

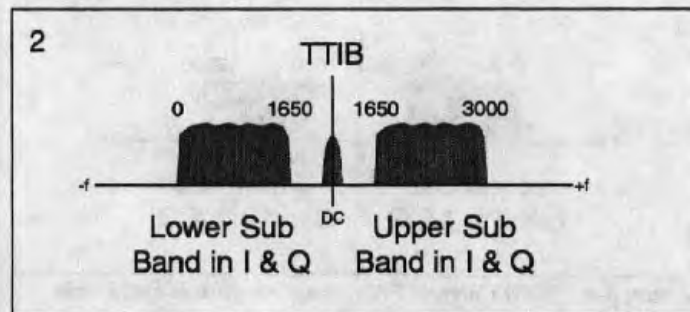

Figure 3-7 Received Signal in I and Q about DC

The amplitude, frequency and phase distortion measured on the pilot tone will be substantially the same as that affecting the two audio sub-bands and that measuring the pilot distortion will be a good measure of overall signal distortion.

This measurement of amplitude, frequency and phase distortion information, is achieved by a comparison against an 'ideal' answer produced by the receiving DSP. The 'answer' to the comparison is then used to equalise the two sub-band signals to negate the introduced distortion.

The pilot tone is then separated from the audio sub-bands (Figure 3-8).

The sub-band signals are then delayed whilst the distortion information derived from the pilot tone is fed forward for processing.

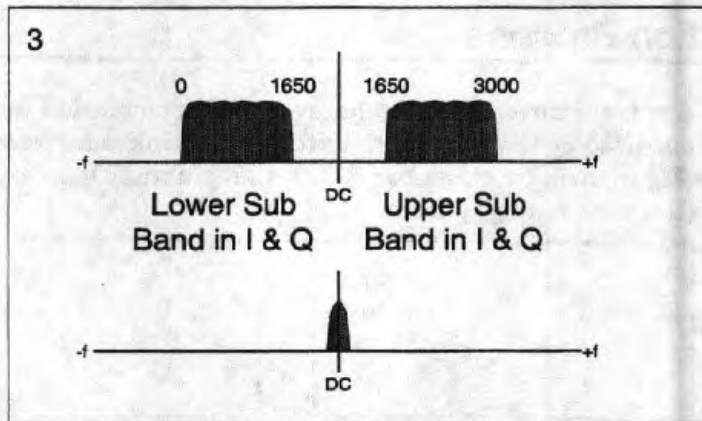

Figure 3-8 Extract Pilot Tone from Received Audio

This ensures that the correction is applied in the correct time frame. This is known as **Feed Forward Signal Regeneration (FFSR)**.

Once the audio has been corrected the rest of the DSP processes are a reverse of the transmission techniques.

The audio, which is still in two associated sub-bands (Figure 3-9) is split into two separate bands and via a two stage mixing process within the DSP (Figure 3-10) reformed into a coherent audio signal, but still symmetrically arranged around 0 Hz (Figure 3-11).

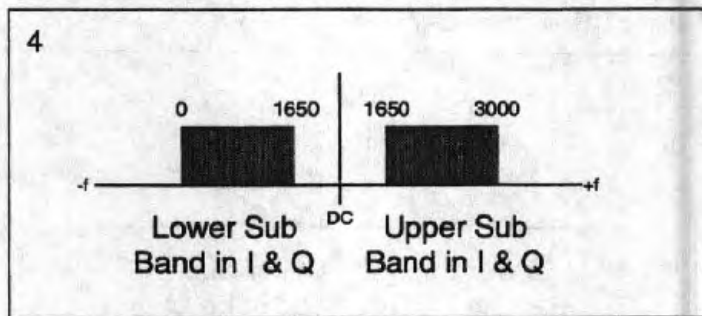

Figure 3-9 FFSR Corrects Frequency, Amplitude and Phase

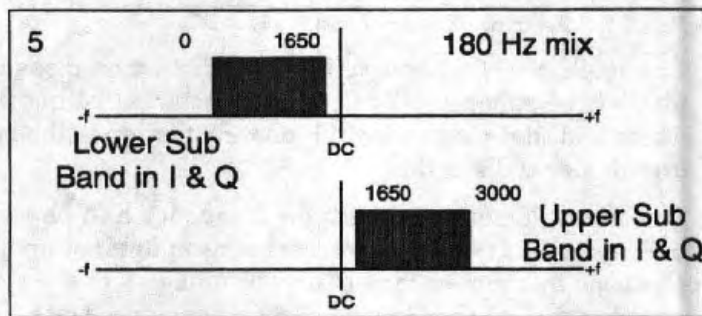

Figure 3-10 Separate Upper and Lower Sub-bands

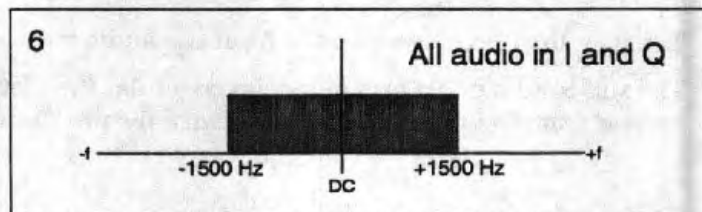

Figure 3-11 Rejoin Sub-bands and Lock Together

The final process recovers the audio into the 'real world'. (Figure 3-12)

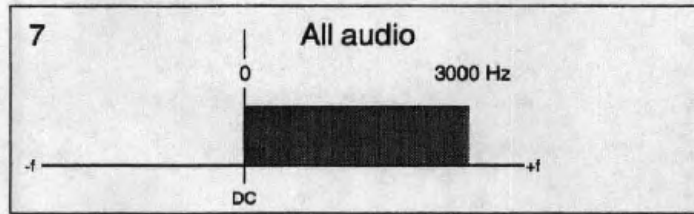

Figure 3-12 Frequency Shift back to Baseband



4. Advanced Digital Network Trunking (ADNT)

Advanced Digital Network Trunking is a message trunking system based on the UK specifications MPT1327 and MPT1343. It provides automatic allocation of channels in response to requests by mobiles or base stations.

For full trunking operation, at least two channels are required.

In operation one channel is a dedicated control channel, and the other channels are used as traffic channels. In some circumstances, the control channel can revert to traffic channel operation.

4.1 Control Channel

The control channel continuously transmits codewords arranged in time-slots. One or more slots (up to 32) form a frame. At power-up mobile radio units (mobiles) must identify the control channel and achieve slot/frame synchronization. In operation mobile units are continuously checking the control channel to ensure that communication is maintained. If a mobile loses the signal, it will look for a new control channel. Authorization and registration of mobiles onto the system takes place over the control channel. As well as system identification information, the codewords also include "Aloha" messages, which are an invitation to the mobiles to request a call.

For small systems or during failure of all traffic channels, the control channel may revert to traffic channel use when the queue becomes full. However, this prevents other mobiles from queueing calls on the system or sending status messages.

4.2 Call Setup and Clear Down

To make a simple one-to-one voice call, a mobile responds to an "Aloha" by sending a call request on the control channel. To minimize clashes, the slot is randomly selected from a frame by the mobile. The repeater then sends out an "Ahoy" message on the control channel demanding a response from the called mobile. If the called mobile receives the "Ahoy" message and is able to accept the call it sends an appropriate acknowledgement message to the repeater. The system selects a vacant traffic channel, and sends a "Go to Channel" (GTC) message, telling both the calling and called mobiles which channel to use.



If the system cannot set up the call¹, even after a number of retries, it will then send back one of a number of acknowledgements to the calling party. If the called party is busy or all the channels are in use, subsequent calls will be put into a queue. When the called party or a traffic channel becomes available, the call will proceed. If this does not happen within a set time limit, the call will be abandoned.

Once a GTC has been sent, the allocated channel repeater will key-up, transmit a short burst of signalling to make sure the channel is clear of any unwanted mobiles, and then switch to talkthrough mode. The mobile users can then talk to each other over the traffic channel. The total duration of the call is limited by a Dynamic Call Timer which will automatically clear the call down after a system-specified interval, determined by time of day and system loading. The call will also be cleared down if no mobile activity is detected for some time.

When the call is cleared down, the TCC sends out a "Clear Down" message on the traffic channel to tell all mobiles on that channel to return to control channel. The traffic channel will then key-down, and be available for use in another call.

¹ eg. Called Party Busy, No Traffic Channel Available, Invalid Call, or no reply to the "Ahoy"

5. Controls, Indicators and Displays

Controls and indicators are provided on the equipment for use during installation and servicing on the radio site.

5.1 System Control Interface

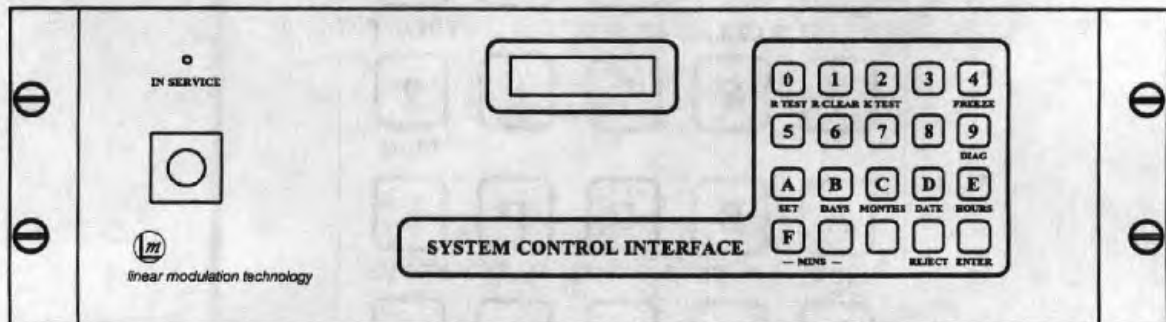

Fig. 5-1: SCI Front panel

The SCI is a 3U high unit which fits into the top slot of the rack. It has a two-line alphanumeric liquid crystal display and keypad for data entry.

When power is applied to the SCI, the LCD display should briefly show these stages during start-up:

- i. Init RAM
- ii. Date and Time
- iii. Power Up OK
- iv. Software version
- v. No. of channels in service
- vi. Bank 1 status
- vii. Bank 3 status
- viii. Current read & write billing data RAM banks
- ix. Time Period
- x. Copyright message

If channels are switched on and working, the "IN SERVICE" LED will illuminate.

RAM bank 2 status is shown if fitted (only required if the system is configured to handle more than 8 prefixes).

Banks 4, 5, 6 status will be shown if fitted for extra billing storage.

Normally the SCI will be controlled either by the System Control Terminal (Syscon) or the Central Computer via a modem/land-line. A 20-way keypad and liquid crystal display provide for some on-site functions:

- i. Set Calendar/Clock
- ii. Initialise RAM bank cards
- iii. Test RAM bank cards



These facilities are provided via Syscon / central computer, described in detail in the Syscon manual, publication reference (TL/12/1.4):

- i. Set Calendar/Clock
- ii. Set system control parameters
- iii. Read system status reports
- iv. Read billing/call statistics
- v. Set customer validation data

5.1.1 The Keypad

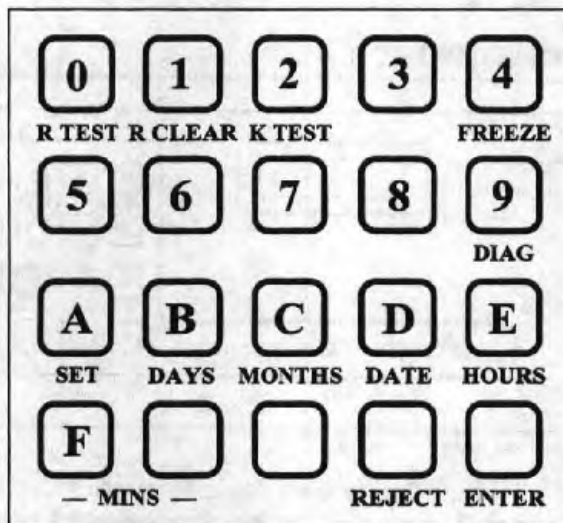

Fig. 3—1: SCI Keypad

5.1.2 On-Site Functions

The top line of the LCD normally displays the Calendar/Clock settings. The bottom line is used to provide a scrolling status display.

The scrolling status display may be frozen at any time (no key required) by pressing "FREEZE". Although the display freezes, the parameters displayed are continuously updated. The freeze function will time-out after 2 minutes and pressing the "FREEZE" key again will extend the freeze by a further 2 minutes. Pressing the "REJECT" key will unfreeze the display.

Setting the Calendar/Clock

The Calendar/Clock may be set as follows:

- i. Turn the Key switch to the ON position.
- ii. Press the "SET TIME" key. The bottom line of the LCD will indicate SET TIME MODE.
- iii. Pressing "DAYS" will increment the day of the week.
- iv. Pressing "MONTHS" will increment the months.
- v. Pressing "DATE" will increment the date. It is important to set months first as this affects the date rollover value.
- vi. Pressing "HOURS" will increment the hours (24 hour clock).
- vii. Pressing "TENS MINS" will increment tens of minutes.
- viii. Pressing "MINUTES" will increment unit of minutes.
- ix. You now have the choice of entering or rejecting your entry.



Pressing the "ENTER" key will enter the new time and update the calendar/clock and exit SET CLOCK MODE. Pressing the "REJECT" key will exit SET CLOCK MODE and use the old time (time-keeping is actually maintained throughout). Removing the keyswitch key will have the same effect as pressing the REJECT key. SET CLOCK MODE will exit automatically after 2 minutes as if the reject key was pressed.

IMPORTANT: Setting the clock "on-site" will cause all billing data to be affected. Setting the clock via Syscon does not affect billing data and is thus the best method of setting the clock.

Initialising RAM Banks

Initialising RAM banks is necessary if a new card is to be installed, or something has corrupted the RAM contents. This function destroys all data on the RAM bank and should be used with care. Proceed as follows:

- i. Insert the key into the keyswitch and turn it to the ON position.
- ii. Press the "DIAGNOSTICS" key. ENTER PASSWORD will appear in the top line of the LCD.
- iii. A 4-digit number must now be entered to gain access to this privileged engineering level. The default value for this password is "2755". If a mistake is made, press REJECT to backspace one character. A bad password will cause an exit from diagnostic modes.
- iv. On correct password entry the FUNCTION REQD. prompt will be given. Press "1" key to select INITIALISE RAM BANK function.
- v. The prompt BANK NO 1-6 will appear. Enter the required RAM bank number. BANK 1 is always used for validation and system control data storage, BANKS 3-6 are used for Billing Data.
- vi. ARE YOU SURE will be displayed. Pressing ENTER will execute the initialise function and then fall back to the FUNCTION REQD. prompt. Pressing REJECT will cause an exit without execution.

Note that pressing REJECT will always cause either an exit from a mode or a backspace through key presses or functions. Pressing ENTER will cause execution of the function before exit.

Testing RAM Banks

Testing a RAM bank may be accomplished as follows:

- i. Assuming that the SCI is not already in diagnostics mode, follow steps i to iii under Initialising RAM Banks above. The FUNCTION REQD prompt should now be displayed.
- ii. Press "0" to select RAM BANK TEST.
- iii. The prompt BANK NO 1-6 will appear. Enter the required bank no.
- iv. The prompt ARE YOU SURE will now appear to which the ENTER or REJECT keys may be pressed. Pressing ENTER will start the test and *all data previously in the RAM bank will be lost.*
- v. The LCD will now display TESTING BANK n on the top line and nnnK Bytes OK on the bottom line. The test can be aborted at any time by pressing REJECT. If the RAM bank fails, the LCD top line will show BANK FAILED and the bottom line will show how many K bytes were tested before the failure was detected. If no errors are detected then BANK PASSED will appear on the top line and 128 Bytes OK on the bottom line. In either case, press any key when you have read the message.



IMPORTANT: ensure that the SCI is not left in diagnostics mode after use otherwise the system will not operate correctly. THERE ARE NO TIME-OUTS in diagnostics modes. Removing the key from the keyswitch or repeatedly pressing REJECT will exit diagnostics.

5.2 Power

All units except the TCC have red LED indicators to show that the power supply is on.

5.3 PA LED

The PA has a green LED which indicates when the channel is transmitting.

5.4 TCC LEDs

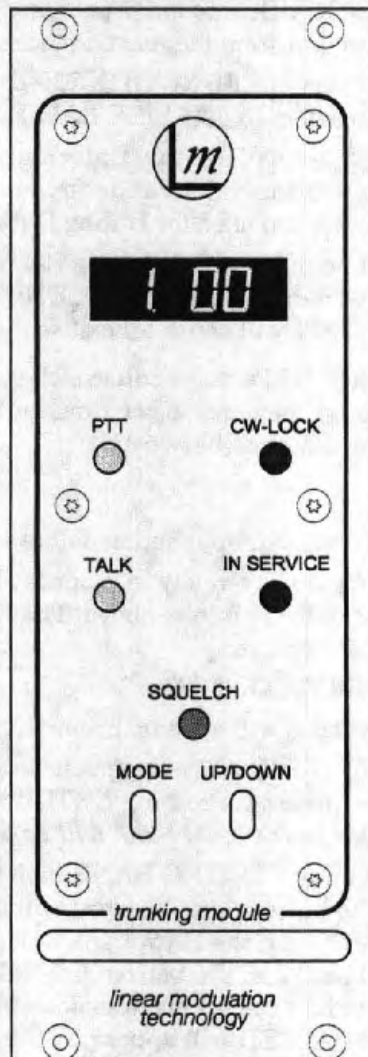

Fig. 3—1: TCC Front panel



5.4.1 PTT

This yellow LED indicates that the TCC is transmitting signalling data. It is illuminated when the channel is operating as control channel, and during call setup and clear down on a traffic channel.

5.4.2 CW LOCK (Code Word Lock)

This red LED indicates each MPT1327 code word that is transmitted from the TCC. It flashes on and off when the channel is operating as control channel.

5.4.3 TALK

This yellow LED indicates that the channel is in talkthrough mode, in which received audio is relayed directly to the transmitter. This LED is illuminated during a call on a traffic channel. The system mutes the audio briefly whenever signalling is detected (e.g. the PTT key on a mobile is pressed or released), and the TALK LED is extinguished briefly when this happens.

5.4.4 IN SERVICE

This red LED indicates that the TCC has powered up correctly and is correctly accessing the SIO bus.

5.4.5 SQUELCH

This green LED indicates that the Receiver module is detecting RF energy on the selected channel at a level higher than the squelch threshold.

5.5 TCC Display

A four-digit LED display provides various information on the TCC status. The information displayed depends on the TCC mode. Because timer values can make the meaning of some of the displays ambiguous, the location of the decimal point is used to indicate which status message is being displayed.

5.5.1 Power Up Sequence

- 03- Rapid count up
- 04- Rapid count up
- 05- Rapid count up



5.5.2 Failure Codes

EQUIPMENT	CODE	FAILURE
TCC	U000 (UU00)	Total failure, cause unknown
	U001	Modem uP fault
	U002	COMRAM fault
	U003	Main uP fault
	U004	SIO bus fault
	U007	I ² C error (SPU fault)
	Transmitter	U008 (UU01)
U013		Tx PA instability
U014		Tx PA over temperature
U015		Tx synth out of lock
Combiner	U016 (UU02)	Tx has detected high reflected power
Receiver	U024 (UU04)	Continuous open squelch
	U031	Rx synth out of lock
Line Interface	U032 (UU05)	LIFU has failed
Data Interface	U038	DIFU has failed (under development)
Note: Codes in parentheses to be superseded in future versions.		

5.5.3 Normal Operation (Control Channel)

When operating as a control channel, the status display continuously cycles round the following messages:

- 1. 00 SIO Bus address (set to 00 for control channel)
- 20.01 Channel Number (e.g. 001 for a Tx frequency of 220.0025 MHz)
- 3 0.0 The number of calls currently on the queue (eg 0)
- 1-00. The dynamic call time value (minutes and seconds) which will be given to a call (e.g. 1 minute)

5.5.4 Normal Operation (Traffic Channel)

When operating as a traffic channel, the status display continuously cycles round the following messages:

- 1. 02 SIO Bus address (e.g. 02)
- 20.31 Channel Number (e.g. 031 for a Tx frequency of 220.1525 MHz)
- 3 U.A Unused status code
- either 4 --. No call in progress
- or 3 47. Time remaining for current call (e.g. 3 minutes 47 seconds)

Note: If the TCC is powered up with the MODE switch held down, a special test mode is executed that suppresses detection of I²C bus errors. This enables the unit to be tested without exciter and/or receiver modules connected.

5.6 TCC Internal Controls

The TCC has five internal BCD switches labelled A to E that allow it to be set up for a particular system configuration and site installation, and a variable resistor to adjust the FFSK output level, explained below.

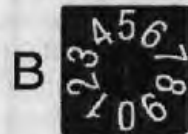
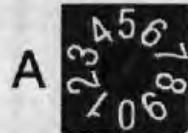

To gain access to the switches, switch off the power supply, disconnect the leads from the back of the module, unscrew the knurled retaining screws, remove the module from the channel shelf and unscrew the access plate. It is also possible to make adjustments to the switches while the unit is powered by unscrewing the knurled retaining screws on the front panel of the TCC and then carefully pulling it forward sufficiently far to allow removal of the access plate.

Note: Some versions do not have an access plate, the side of the TCC unit must be removed to gain access to the switches.

The switches are adjusted using a suitable thin-bladed screwdriver.

5.6.1 SIO Bus Address

The SIO Bus Address gives each channel a unique identity on the bus, and allows the TCCs to decide which channel is used as the control channel. The address is set using the top two rotary BCD switches (A & B) inside the TCC unit. TCCs may have addresses 0 to 23 inclusive, but it is recommended that the lowest numbers possible are used. No two TCCs should have the same SIO bus address.

The TCC with the lowest address normally becomes control channel, and takes on a temporary address of 00. Thus, if the channel being used as a control channel fails then the channel with the next lowest SIO bus address will take over as control channel. If a TCC is set to address '00' then this can only ever be used as a control channel. The delay time before a TCC becomes the control channel is also determined by the SIO Bus Address in order to prevent two units trying to take control at the same time.

5.6.2 Channel Number

The channel number determines which frequencies the transmitter and receiver will operate on. It is selected by the lower three rotary BCD switches (C to E) inside the TCC unit. The channel number is the number allocated by the FCC to the selected frequency pair. The base receiver channel centre frequency can be calculated using the equation:

$$\text{Chan Frequency} = \text{Chan 1 Frequency} + \text{Chan spacing} \times (\text{FCC Chan No.} - 1)$$

Example, for Channel 50:

$$\begin{aligned} \text{Base Rx Frequency (MHz)} &= 221.0025 + 0.005 \times (50 - 1) \\ &= 221.2475 \text{ MHz} \end{aligned}$$

A full list of frequencies for the 220 MHz band is included in section 12.

The channel selected in the TCC must correspond to the frequency that the cavity in the combining rack is tuned to. Refer to the Trunking Reference Manual (TL/13/1.1) for details.



NOTE: On multi-site systems there is a fixed relationship between SIO bus Addresses and RF Channel Numbers. It is important to ensure that the correct address/channel values are set otherwise the same RF channel may not be selected on both sites in an inter-site call, and interference may occur in overlapping coverage areas.

5.6.3 FFSK Output Level

The trunking signalling is generated by a Fast Frequency Shift Keying (FFSK) modem in the TCC. The level of the signal coming out of the modem is adjustable using the variable resistor VR1, located on the top edge of the circuit board inside the TCC unit. The level measured at Pin 5 of SK2 Tx should be set to a maximum of 1V peak to peak. No adjustment is normally required. To output FFSK, the TCC should be operating either as control channel, or in the test mode which generates continuous preamble. This is selected by setting the SIO Bus address switches to 96. The FFSK output level is preset at the factory and should not need to be changed.

5.7 TCC Front Panel Controls

5.7.1 Squelch Level

The squelch level determines what level of RF signal must be detected by the receive module before the audio mute is opened. The threshold should be set so that the mute is not opened by the ambient RF noise on the site, but is opened by a mobile transmitting at the limit of its operating range. If during a call on a traffic channel no signal is detected above the squelch threshold, an inactivity timer may prematurely clear down the call.

The squelch level is set using the two switches on the front panel of the TCC unit. The state of the squelch is indicated by the green LED at the bottom of the TCC. The LED should only be illuminated if a mobile is transmitting on that channel.

When the display is showing one of its normal four displays, press the MODE (left hand) switch down once. The display will show "5-" followed by a two digit value.

e.g. 5- 15 Set Squelch Threshold to 15

The value can be incremented by pressing the UP/DOWN (right hand) switch upwards, and decremented by pressing it downwards. If no activity is detected on either of the switches for a few seconds, the display will resume its normal cycle.

The value 00 selects the lowest squelch level, and 63 selects the highest.

The squelch level can be set on site by gradually increasing the setting as detailed above, until the green squelch LED is off all the time (i.e. the ambient noise level on the site is not lifting the squelch).



5.7.2 FFSR Threshold Level

The FFSR threshold limits the gain of the receiver in the presence of deep fading. It improves the intelligibility of voice when the mobile is at the edge of the coverage area of the repeater.

When the display is showing one of its normal displays, press the MODE switch down twice. The display will show "6-" followed by a two digit value.

e.g. 6-32 Set FFSR threshold to 32

The value can be incremented by pressing the UP/DOWN switch upwards, and decremented by pressing it downwards. If no activity is detected on either of the switches, after a few seconds the display will resume its normal cycle.

The value 00 selects the lowest FFSR threshold level, and 63 selects the highest. The default value for the FFSR threshold is 32.

5.7.3 Pilot Pumping

Pilot Pumping increases the transmitted level of the TTIB pilot tone by 6 dB in the absence of modulation. This effectively reduces the noise heard during gaps in speech when a mobile is in a weak signal area.

When the display is showing one of its normal displays, press the MODE switch down three times. The display should show:

e.g. 7-00 Pilot Pumping Off

7-01 Pilot Pumping On

The state can be toggled using the UP/DOWN switch. If no activity is detected on either of the switches, the display will resume its normal cycle after a few seconds.

The default setting for Pilot Pumping is On.

5.8 Frequency Standard

5.8.1 Internal/External Select

A switch on the rear of the Frequency Standard selects either the internal ovened oscillator reference for stand-alone operation, or an external reference source when slaved to another repeater.



5.7.2 FFSR Threshold Level

The FFSR threshold limits the gain of the receiver in the presence of deep fading. It improves the intelligibility of voice when the mobile is at the edge of the coverage area of the repeater.

When the display is showing one of its normal displays, press the MODE switch down twice. The display will show "5-" followed by a two digit value.

e.g. 5-32 Set FFSR threshold to 32

The value can be incremented by pressing the UP/DOWN switch upwards, and decremented by pressing it downwards. If no activity is detected on either of the switches, after a few seconds the display will resume its normal cycle.

The value 00 selects the lowest FFSR threshold level, and 63 selects the highest. The default value for the FFSR threshold is 32.

5.7.3 Pilot Pumping

Pilot Pumping increases the transmitted level of the TTIB pilot tone by 6 dB in the absence of modulation. This effectively reduces the noise heard during gaps in speech when a mobile is in a weak signal area.

When the display is showing one of its normal displays, press the MODE switch down three times. The display should show:

e.g. 7-00 Pilot Pumping Off

7-01 Pilot Pumping On

The state can be toggled using the UP/DOWN switch. If no activity is detected on either of the switches, the display will resume its normal cycle after a few seconds.

The default setting for Pilot Pumping is On.

5.8 Frequency Standard

5.8.1 Internal/External Select

A switch on the rear of the Frequency Standard selects either the internal ovened oscillator reference for stand-alone operation, or an external reference source when slaved to another repeater.

6. Installation

6.1 Performance Tests

Although all units are carefully aligned and tested at the factory, it is good practice to check the performance of both transmitter and receiver modules immediately before placing them in service. This will ensure correct operation and prevent interference with other site and band users. Sections 10 and 11 illustrate how to check and adjust the performance of the unit. Refer to Section 1 for specifications.

6.2 Power Supply

Four variants of power supply unit are available operating at 110 V or 240 V and 200 W or 400 W. The 25 W and 100 W Repeaters require 200 W and 400 W PSUs respectively. Check the voltage on the labels next to the power connectors on the rear panels of the SCI and shelf units, before connecting the equipment to the supply.

The Frequency Standard has a switch on the rear panel to select between 110 V and 240 V. Check that this is set appropriately.

NOTE: An incorrect voltage rating may result in permanent damage to the equipment.

6.3 Location

The Repeater Equipment should be located in a suitable site equipment room, and should have access to the antenna feed, AC power, station earth and a connection to a SYSCON terminal, via modem and phone line if necessary.

Adequate space (1m) should be allowed between the rear of the cabinet and any walls to allow for engineering access and adequate airflow.

The site must:

- ◆ be secure
- ◆ preferably have air conditioning and heating (if in a very cold area).
- ◆ be devoid of excessive dust ingress
- ◆ be free of water leaks and the danger of flooding
- ◆ have easy access to premises at all times
- ◆ be accessible during inclement weather (inc. snow, floods etc.)
- ◆ preferably have power supply back up
- ◆ be accessible by wire line or microwave link for voice and data fixed link access
- ◆ be free of rodent infestation
- ◆ be large enough to take the equipment racks (both in floor area and height)
- ◆ be large enough for future expansion of the system



6.4 System Control Interface

The SCI is a 3U high unit which fits into the top slot of the rack. Screw the unit into the rack using the four pan-head screws and plastic cups provided.

- ◆ Connect the power supply from the distribution panel on the rack using the IEC lead provided.
- ◆ Connect the earthing stud on the side of the unit to the earthing strip on the rack using the green and yellow striped cable provided.
- ◆ Connect the SIO bus lead to the screw terminals. The wires are colour coded as below:

Blue	T
Clear	C
Screen	SCN

When power is applied to the SCI, the LCD display should briefly show these stages during start-up:

- i. Init RAM
- ii. Date and Time
- iii. Power Up OK
- iv. Software version
- v. No. of channels in service
- vi. Bank 1 status
- vii. Bank 3 status
- viii. Current read & write billing data RAM banks
- ix. Time Period
- x. Copyright message

If channels are switched on and working, the "IN SERVICE" LED will illuminate.

RAM bank 2 status is shown if fitted (only required if the system is configured to handle more than 8 prefixes).

Banks 4, 5, 6 status will be shown if fitted for extra billing storage.

Normally the SCI will be controlled either by the System Control Terminal (Syscon) or the Central Computer via a modem/land-line.

See paragraph 5.1 for description of the control panel for on-site use.

6.4.1 System Control Terminal (Syscon) or Central Computer

Connection to the System Control Terminal (single-site) or Central Computer (multi-site) is via Serial Port A of the SCI. The protocol is half-duplex and uses no handshaking, enabling connection to the terminal or modem with just 3 wires. All data transfers are in raw binary format to maximise link throughput.

The SCI will not respond if a sumcheck failure, framing overrun or parity error is detected.

NOTE: Maximum cable length without modems is 10 metres.

Port B is reserved for future use.



6.5 Channel Setup

Before assembling the system, make sure that the SIO bus address and Channel Number are set up correctly in each TCC. Remove the TCC's access plate and set the SIO bus address using the top two rotary BCD switches (A and B). Set the Channel Number using the bottom three BCD rotary switches (C, D and E). Replace the plate, return the TCC to the channel shelf and reconnect the cables at the rear.

For a single site 5 channel system, the SIO bus addresses should be set between 01 and 05. If there are more than 5 channels on a site, they should be given consecutive addresses. For multi-site systems, intersite channels and pooled channels should have the same SIO bus address on all sites.

The Channel Numbers must correspond to the frequency allocation in the operator's licence. These should be separated by at least 150 kHz (30 channels) for combining to operate within specification. It must be ensured that each cavity and circulator pair is tuned to the output frequency of the channel shelf to which it is connected (see paragraph 6.7.1 on page 6–6). Duplexers should be tuned specifically for the set of channels allocated.

6.6 Repeater Rack

The Channel Shelves, Frequency Standard and SCI are shipped from the factory in separate packaging. The rack itself is shipped with cabling, power distribution and blanking panels fitted.

The units slide into the rack and are connected at the rear of the cabinet. The cabinet should be filled from the bottom up to reduce the risk of toppling and facilitating setup.

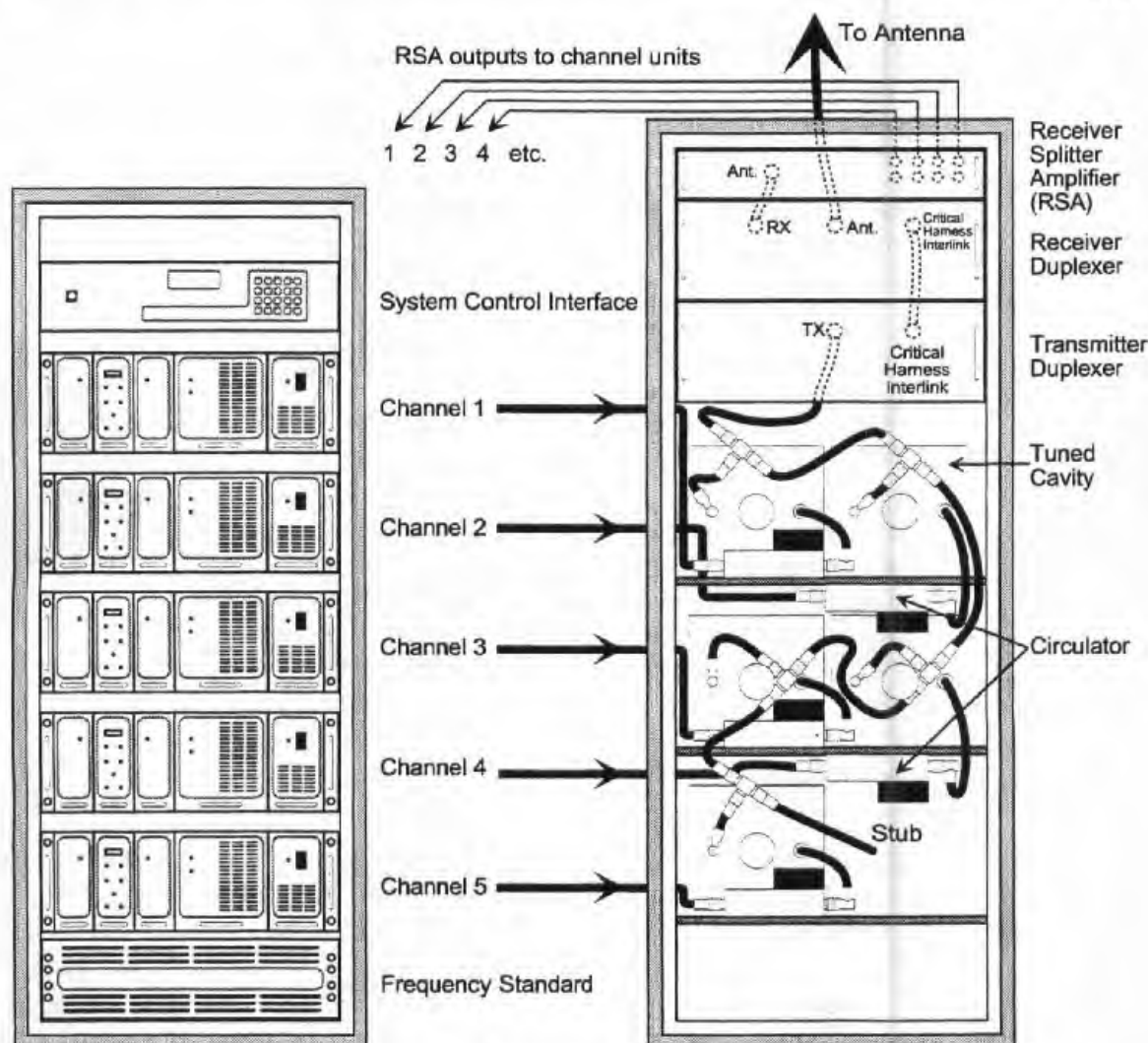

Figure 6-1: Front view of Repeater Rack and Standard Combining Rack
(Other combining racks may look different from this).

6.6.1 Frequency Standard

The Frequency Standard is a 1U high unit which fits in the bottom section of the rack. Screw the unit into the rack using the four pan-head screws and plastic cups provided.

Ensure that the 110/230 V switch is in the correct position.

Connect the mains power supply from the distribution panel on the rack using the IEC lead provided.

Connect the earthing stud to the earthing strip on the rack using the green and yellow striped cable provided.

Connect the 10 BNC cables to the outputs numbered 1 to 10. One output connector, and the input connector should be left unconnected.

Check that the INT/EXT switch is in the INT position, unless an external frequency source is being used.

6.6.2 Channel Shelves

The next five slots of the rack take the channel shelves which are 4U high units. Screw each unit into the rack using the four pan-head screws and plastic cups provided.

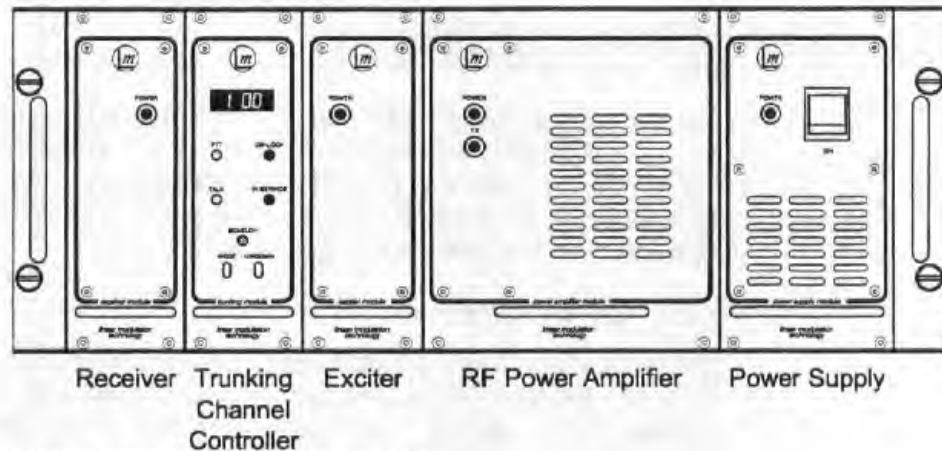

Fig 6-2: Front view of Channel Shelf Unit

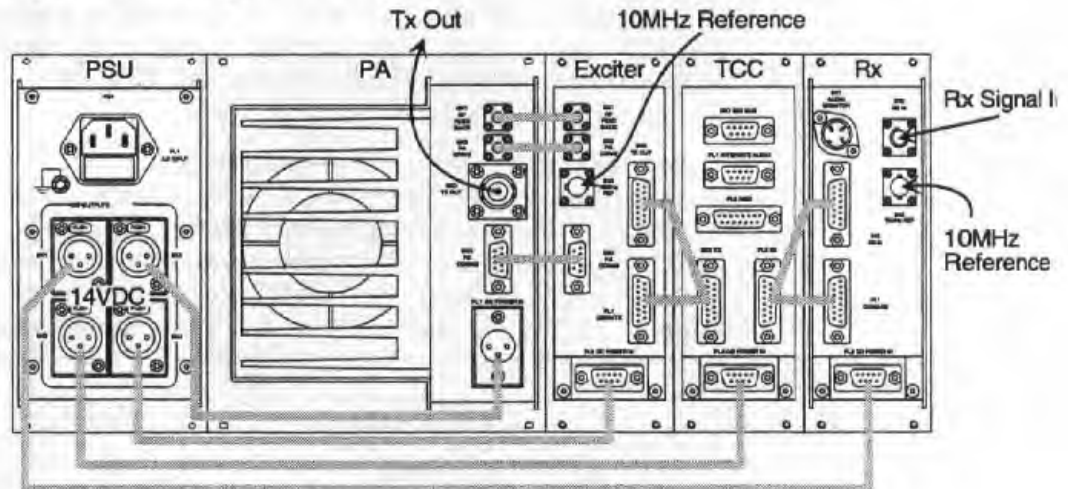

Fig 6-3: Rear view of Channel Unit

- ◆ Connect the power supply from the distribution panel on the rack using the IEC lead provided.
- ◆ Connect the Earthing stud at the centre of the rear edge of the shelf to the earthing strip on the rack using the green and yellow striped cable provided.
- ◆ Connect the Frequency Reference BNC leads to the 10 MHz REF connectors on the Receiver (SK4) and Exciter (SK3) modules.
- ◆ Connect the receive antenna lead to SK3 RX IN (TNC connector) on the Receiver Module. See section 6.7.2 for details of connection to the combining rack.
- ◆ Connect the thick transmit antenna lead to SK3 TX OUT (N-type connector) on the PA module. See section 6.7.3 for details of connection to the combining rack.
- ◆ Connect the 9-way D-type lead to the SIO BUS connector (SK1) on the TCC.



6.6.3 Earth Connection

Connect the Station Earth to the earth strap at the base of the repeater cabinet using a heavy duty cable or braid.

6.7 Combining Rack (optional)

The combining rack may be shipped from the factory ready assembled. The only connections that have to be made are from the repeater rack to the combining rack, and from the combining rack to the antenna. A single antenna is normally used for transmit and receive, though two-antenna systems have some advantages.

6.7.1 Cavity Alignment

The tuning of the cavities and duplexers should be checked to make sure that they have not shifted during shipment. The same procedure should be used if the tuning is to be changed for any reason. Also, check that the rigid interconnects are intact.

A spectrum analyser with a tracking generator is required. Connect the output of the tracking generator to the input of the circulator for the channel to be adjusted. Connect the input of the spectrum analyser to the antenna port of the combining rack.

Set the centre frequency of the analyser to the required channel, and set the span to 100 kHz. The peak of the response should fall on the channel centre. To adjust the position of the peak, loosen the two fixing screws which grip the shaft of the plunger, and gently tap the plunger in or out. If the plunger is already too far in then pull it out a short distance before tapping in. Tighten the fixing screws to lock into position.

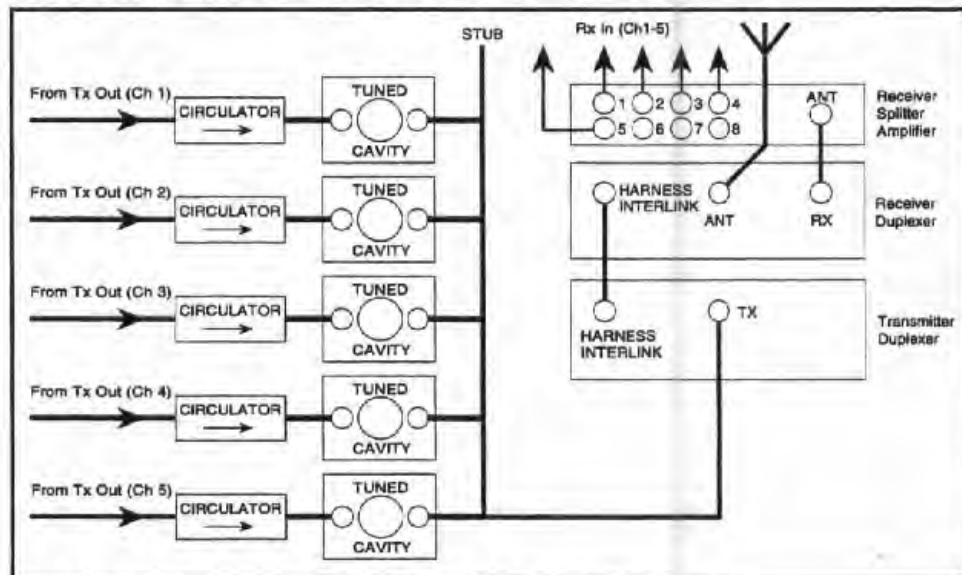

Fig. 6-4: Schematic diagram of Combining Rack

6.7.2 Receiver Connections

The receiver modules should be connected to the output terminals of the RSA. The rack is supplied with standard thickness cables, with TNC connectors for the receiver module end, and N-type connectors for



connection to the RSA. Any channel can be connected to any of the RSA terminals.

6.7.3 Transmitter Connections

The PA modules are connected to the input of the circulators. The rack is supplied with thick cables, with N-type connectors on both ends. The circulators and cavities are tuned to specific frequencies. Therefore each channel must be connected to the correct circulator. The channel number is set within the TCC, and is indicated on a label on the rear of this module. The PA module should be connected to the circulator labelled with the corresponding frequency.

If different frequencies are required, the cavities must be retuned.

6.7.4 Antenna Connection

The Antenna feed is connected to the ANT port (N-type connector) on the Duplexer. Low-loss feeder cable must be used, and run lengths must be kept to a minimum.

6.7.5 Earth Connection

Connect the Station Earth to the earth studs on the RSA and Duplexer units using a heavy duty cable of braid. This connection back to the station earth must be of the lowest impedance possible to minimise noise and give maximum protection against lightning. A lightning surge protector may be fitted in-line with the antenna coax.

7. Operation

The operation of the Repeater Site is automatic, with system supervision provided by SYSCON (Ref. TL/12/1.4). This section describes the procedure for setting up and testing the system on a site.

7.1 Power Up

The Frequency Standard should be powered up for at least 15 minutes before the rest of the system to ensure that it has stabilised. Make sure that all the channel shelves are turned off on the front panel of their Power Supply Modules. Plug in the cabinet power cord. The red LED on the front panel of the Frequency Standard indicates that the unit is switched on.

Ensure that all the TCCs have been set-up correctly, in particular that the channel numbers coincide with the frequencies that the combining cavities have been tuned to. Check that the transmitter outputs are connected to the combining, or a suitable 50 Ω dummy load, with sufficient power rating. Turn on each channel using the switch located on the front panel of the Power Supply Module starting with the desired control channel. When the TCC is switched on, it goes through a power-up sequence during which it checks that it can communicate with the Receiver and Exciter modules. See paragraph 5.5 for details.

7.2 Control Channel Selection

All the channels that are powered up will begin a dialogue over the SIO bus to determine which will become control channel. The channel selected as control channel will key up, and start to transmit control channel signalling. The other channels will remain idle until a mobile makes a call.

Only one channel should be operating as control channel, and this can be verified by observing that:

- ◆ Tx LED on the PA is on
- ◆ 100 W PA cooling fan rotating at high speed.
(25 W PA fan has two speeds: high when transmitting, low when idle)
- ◆ CW-LOCK LED on the TCC is flashing steadily
- ◆ PTT LED on the TCC is on
- ◆ Display cycles round normal control channel sequence

The control channel performs an automatic self-calibration every two minutes to optimise the performance of the transmitter. This has no appreciable effect on the operation of the system.



The other channels should remain idle unless a call is being made on the system. Check this is the case by observing that:

- ◆ Only IN-SERVICE LEDs are on
- ◆ Display cycles round normal traffic channel sequence
- ◆ Tx LED on the PA is not on
- ◆ PA cooling fan rotating at low speed (25 Watt version only).

7.3 Squelch Setting

If no mobiles are transmitting, all SQUELCH LEDs should remain off, otherwise adjust the squelch level on affected channels until the LEDs are extinguished. See section 5.7.1 for instructions on how to set the squelch level.

If the squelch setting has to be set to about 20 or above on all channels to make the LEDs go out, some site engineering is required to reduce interference.

7.4 During a Call

When a call is made by a mobile, one of the traffic channels keys up. Check that this happens by observing that:

- ◆ Tx LED on the PA is lit
- ◆ PA cooling fan rotation increases to high speed (25 Watt version only)
- ◆ TALK LED on the TCC is lit
- ◆ Display cycles round normal traffic channel sequence
- ◆ SQUELCH LED lit when mobile transmits

Clear the call down, and check that the channel returns to the idle state.

When the system allocates traffic channels for successive calls, it cycles round the available channels so that they get equal use. Channels with special resource (e.g. inter-site connections) will not be used for ordinary voice calls until all the other channels are busy.

Repeated calls should be made until all the channels have been checked.

8. Circuit Description

This section describes the overall design of the circuits in the Repeater Site equipment. Component references refer to the circuit diagrams which can be found at the back of this manual.

8.1 Receiver

The receiver consists of the Radio Frequency Unit (RFU) and the Signal Processing Unit (SPU). The RFU converts 221 to 222 MHz RF signals down to a 12.5 kHz IF. The SPU contains a digital signal processor (DSP) which implements the baseband digital signal processing functions required for TTIB demodulation and FFSR channel equalisation. The SPU also generates the analogue control signals for the RFU, and contains the power supply for the module, which takes the 14 V supply from the PSU and generates the various voltages needed in the receiver.

RF signals from the antenna are passed through an RF amplifier (TR1) and a bandpass image filter to a mixer MX1. The signal is mixed with the first local oscillator down to a 45 MHz IF. The signal is then filtered by a 4 pole crystal filter (F1) and amplified by TR8. A PIN diode attenuator (D3 to D7) allows the amplitude range of the IF signal to be controlled. After further filtering by a second 4 pole crystal filter (F2), the signal is applied to a second mixer (IC3). The signal is mixed with the second local oscillator down to a 12.5 kHz IF and then amplified and filtered by the second IF amplifier (IC2C, IC2D). The signal is passed to the SPU in balanced format.

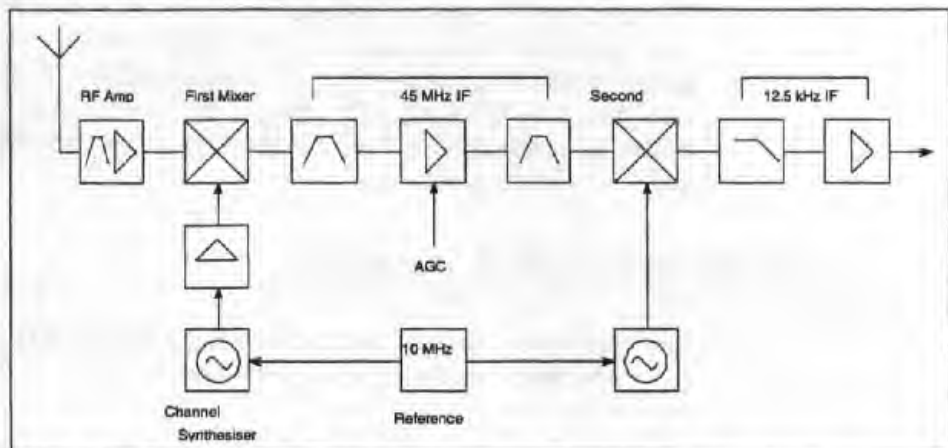

Fig. 8-1 LM Receiver RF & IF

The SPU digitises the incoming signal within U32. The result is processed by DSP device U16. Initially, a digital channel filter is implemented followed by Feed Forward Signal Regeneration (FFSR) which removes fading from the signal using a known reference tone at the centre of the band. Following FFSR, both the reference tone and a



gap created for it are removed using a Transparent Tone In Band (TTIB) demodulator. The output is converted into a continuous analogue signal within U30 after which it is buffered and output directly to an analogue data port via U13 and an FFSK data port via U14.

The circuit boards for the Receiver Module are similar to those for the mobile. The compander, U37, and the audio power amplifier, U34, are not used in the Repeater.

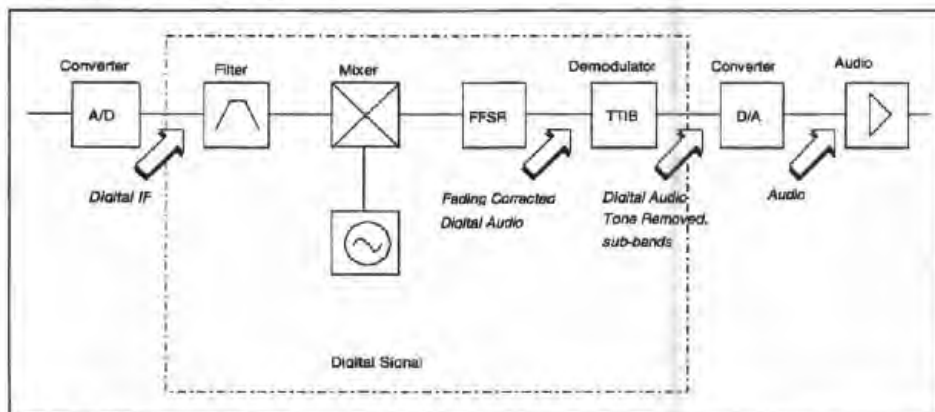

Fig. 8-2 LM Receiver AF

The second local oscillator uses a 180.05 MHz (Issue 4 RFUs, 180.00 MHz Issue 5 RFUs) voltage controlled oscillator formed around TR9. The control voltage for this oscillator is from a synthesizer (IC5) and a low pass filter (IC6A). Frequency reference for the synthesizer is provided by an external 0.1 ppm 10.00 MHz frequency standard. The second local oscillator frequency is therefore locked to the frequency standard and exhibits the same stability. The VCO output is buffered by TR10 then divided by 4 by IC7 to give 45.0125 MHz (Issue 4) or 45.000 MHz (Issue 5) and then applied to the second mixer.

The first local oscillator module uses a 704 to 708 MHz voltage controlled oscillator formed around TR1. The control voltage for this oscillator is from a prescaler (IC4), synthesizer (IC5) and a low pass filter (IC6B). Frequency reference for the synthesizer is provided by an external 0.1 ppm 10.00 MHz frequency standard. The first local oscillator frequency is therefore locked to the frequency standard and exhibits the same stability. The VCO output is divided by 4 by IC7 and amplified by TR2 before being applied to the first receiver mixer. Voltage regulators IC1 and IC2 ensure clean supply voltages.

8.2 Exciter and Power Amplifier

The Exciter consists of an SPU and RFU. The Power Amplifier is a separate board mounted in its own module, with a heatsink and a cooling fan.

The SPU accepts signals from either an analogue data port or an FFSK data port (both via U15 and switched by U36). The signal is digitised by U32 and then processed by DSP device U16. The signal processing implements a Transparent Tone In Band (TTIB) modulator which creates a notch in the centre of the audio spectrum and inserts a reference tone for use in the receiver. The resulting signal is output, in quadrature format, to the RFU via DAC U30.

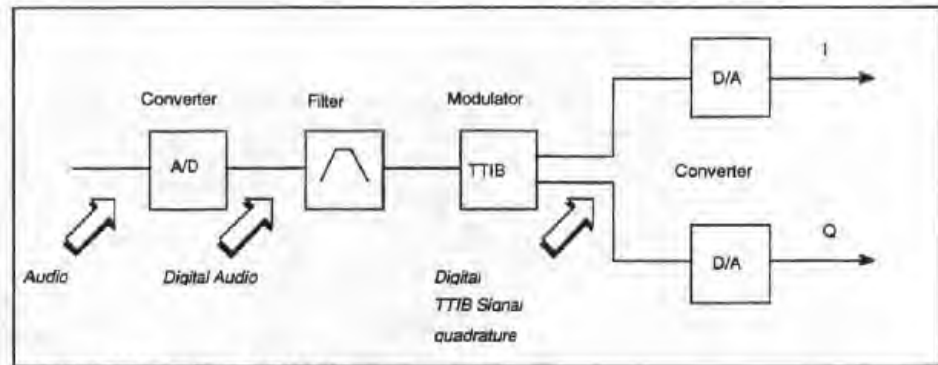

Fig. 8-3 LM Receiver AF LM Transmitter AF

The RFU accepts baseband I and Q drive signals from the SPU, converts them to a composite signal at final frequency, then passes them to the Power Amplifier Module which amplifies the signal to rated transmit power. To achieve a combination of high efficiency and linearity, a Cartesian loop transmitter is used.

The I and Q baseband signals are amplified and filtered in IC25 and IC29. The signals are then passed through high gain error amplifiers IC26 and IC30 to a quadrature modulator (MX4 and MX5). Sample and hold amplifiers IC27 and IC31 allow DC offsets (and therefore carrier leakage) within the system to be minimised. An analogue switch (IC28) connected to the error amplifiers allows the loop to be broken for calibration. The output of the quadrature modulator is amplified by TR30 and TR31 then passed to the Power Amplifier Module (PA). In the PA, the signal is amplified by TR3 and IC1 up to the rated power level. The signal is passed through a harmonic filter and directional coupler to the antenna socket.

The coupler output is returned to the RFU and converted back to baseband I and Q signals by a quadrature demodulator (MX6 and MX7) and amplified by IC37 to IC40 where it is compared with the original I and Q drive signals in the error amplifier. Variable resistor R293 allows the I-Q amplitude balance to be adjusted. The loop therefore allows a large degree of negative feedback linearisation to be applied to the transmit system. This ensures that the unwanted products generated by the transmitter are within required limits. To ensure that the phase of the feedback is always negative, the phase of the up converter local oscillator is controlled by the SPU. The output of the phase shifter is amplified by TR26 before application to the LO port of the quadrature modulator.

The output of the Q feedback channel is high-pass filtered and peak detected to allow out of channel radiation to be detected. This signal, the I and Q feedback signals and DC voltages proportional to forward RF power, reflected RF power and temperature and are passed to a multiplexer (IC41) on the RFU. The selected output from the multiplexer is buffered by IC33D and passed to the SPU as a balanced signal by IC42. The SPU can therefore fully monitor the state of the transmissions and reduce output power or switch to receive mode if any fault conditions are detected.

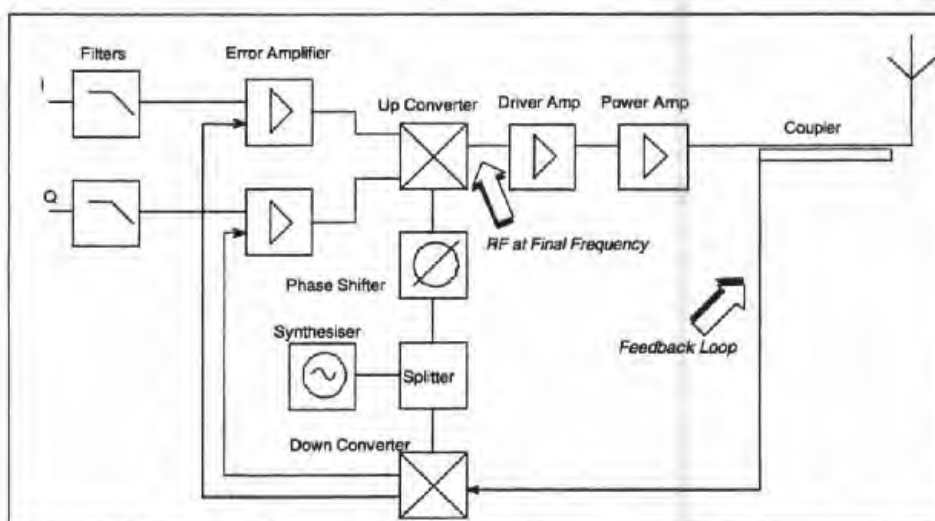

Fig. 8-4 LM Transmitter RF

The first local oscillator module uses a 880 to 884 MHz voltage controlled oscillator formed around TR1. The control voltage for this oscillator is from a prescaler (IC4), synthesizer (IC5) and a low pass filter (IC6B). Frequency reference for the synthesizer is provided by an external 0.1 ppm 10.00 MHz frequency standard. The first local oscillator frequency is therefore locked to the frequency standard and exhibits the same stability. The VCO output is divided by 4 by IC7 and amplified by TR2 before being applied to the transmit local oscillator splitter. Half of the signal is direct to the I-Q demodulator, the other half is passed to the phase shifter. Voltage regulators IC1 and IC2 ensure clean supply voltages to the circuit.

The transmitter periodically performs an automatic calibration of the Cartesian Loop. This operation has three functions:

- ◆ Carrier Suppression The Sample and Hold circuits are used to remove DC offsets from the I and Q paths.
- ◆ Image Suppression The DSP pre-distorts the drive signal to optimise the amplitude and phase of the I and Q paths.
- ◆ Loop Stability The Phase shifter adjusts the phase between the drive and feedback signals.

8.3 Trunking Channel Controller

The channel cards utilise two 6303R microcomputing units (MCUs) running in anti-phase to provide the processing power.

THE MASTER CLOCK formed by IC2 (74HC04) runs at 4MHz and in conjunction with the phase-corrector formed by part of IC3 (74HC00) supplies each MCU with 4MHz clocks which are guaranteed to be in anti-phase. Each MCU divides the master clock by 4 to provide E at 1MHz. Since the 6303R MCU only accesses external devices (such as memory) when E is at logic 1, if the E clocks are in anti-phase then coincident access to common memory is avoided.



IC25 (62256) forms 2K bytes of RAM common to both MCUs (COMRAM). IC10,11,12 (74HC157) switch the address and R/W lines from the accessing MCU.

Data Bus switching is effected by the 2 tri-state transceivers IC15,16 (74HCT245). This enables protocol-free data transfers between processors by simply reading from and writing to common memory, thus greatly enhancing computing power.

THE MODEM PROCESSOR comprises IC6 (6303R), IC5 (6321), IC13 (C256), IC7 (74F138), and its watchdog timer IC4 (4521). IC8 (FX419) is the FFSK modem device which in conjunction with the limiting amplifier IC9 (081) forms a full-duplex FFSK port.

THE MAIN PROCESSOR comprises IC18 (6303R), IC19 (6321), IC20 (27C256), IC21 (M48T18) 8K X 8 Lithium Battery Backed RAM, IC22 (74F138), IC23 (8820), IC24 (8831) and its watchdog timer IC14 (4521).

WATCHDOG TIMERS on each processor ensure that in the event of an untrappable MCU error, a hardware reset will occur within 131ms. On power-up, the reset circuit formed by IC1a, IC1b, IC1c (74HC02) ensures that the processors are held in a reset condition until the supply voltage is stable.

8.4 Power Supply Unit

The incoming mains supply is taken via an input fuse and in-rush control circuit to a rectifying and smoothing stage. A filter limits the radio frequency interference conducted back into the mains. The rectifying and smoothing stages produce a DC voltage of approximately 350V. This DC voltage is then switched into a transformer at 100 kHz using power MOSFETS, in a diagonal bridge, forward converter circuit.

A feed-forward circuit maintains the mean voltage applied to the transformer constant throughout the input voltage range. The converter then feeds four output modules which are isolated from each other by being driven from separate transformer windings. Switching post regulators achieve high power, stable outputs.

8.5 Frequency Standard

The Frequency Standard consists of a 0.1 ppm 10.0 MHz Ovened Oscillator (OCX01). A variable resistor (R22) is provided for calibrating the output frequency. A switch (SW4) selects between the internal reference and an external source via IC4. The signal is then buffered by IC5 and IC1, IC2, and IC3 to drive 11 outputs. Each output is then filtered.

8.6 System Control Interface

The SCI is built into a standard 19 inch rack-mounted case. There are 2 main board assemblies.



8.6.1 Main Board

The main board utilises a single 6303R MCU running at 1MHz to provide the processing power.

IC1 (6303R) internal clock is used to generate the master bus timing. IC10 (4060) forms an additional clock running at 4.9MHz which is used as the BAUD-RATE generator for the two RS232C ports formed by IC13,14 (6350) and IC12,15 (MAX232).

The SIO bus circuit is similar to the channel card design, IC7 (8820) and IC8 (8831). IC2 (4521) is the watchdog timer as in the channel cards. A 2x16 character Liquid Crystal Display (LM016) mounted on the front panel is driven directly from the main processor bus.

IC22 (74C923) provides the required encoding and de-bounce characteristics from the 20 way keypad mounted on the front panel.

IC20 (58174A) is a Calendar/Clock device which is battery-backed to keep time for up to 30 days in the absence of power.

IC21,23,24 (6321) form the SLOW-BUS which is used to access the calendar/clock device and the RAM BANK board.

IC16 (6264) is used as 8K bytes of scratch-pad RAM. IC18,19 (62256) form 64K bytes of high-speed validation RAM. TR1 and TR2 form a 'power-glitch' detector. When the incoming unregulated supply falls below 8V, an interrupt is generated within the MCU. The service routine to this interrupt ensures that all RAM BANK accesses are terminated in a tidy fashion to avoid memory corruption.

IC3,4 (74HCT244) and IC5,6 (74HCT245) buffer the processor address and data buses.

IC28 (74HCT138) is the memory address decoder providing 8K boundaries thus enabling 2764 or 27128 EPROMs to be used.

IC27 (74HCT138) is the auxiliary decoder providing 4 byte boundaries in zero-page for addressing the external I/O devices. This increases the efficiency of I/O functions.

8.6.2 RAM Banks

IC9-24 (6264) form a BANK of 128K bytes of battery-backed CMOS RAM which is capable of retaining data for up to 30 days in the absence of main power.

All the RAM is addressed via the slow bus from the main board.

IC3 (74HC138) in conjunction with the BANK select header ensure that the board is only enabled when the correct bank number has been set. Note bank numbers 0 and 7 are reserved and cannot be addressed.

IC6,7 (74HC138) decode address lines A16-13 thus providing the chip enable lines to each of the 16 8K byte RAM devices.

IC1 (8211) disables the RAM if supply failure is imminent. TR1 and TR2 form the NiCad charger circuit and power switch which prevent RAM corruption during power interruptions.

The POWER-ON LED (RED) illuminates when the RAM BANK is supplied with +5V and the NiCad battery is not totally discharged. A switch on the edge of the board enables the RAM BANK.



The ENABLE LED (GREEN) illuminates when the switch is in the enable position and the RAM BANK may be accessed by the main board.

The SELECT LED (YELLOW) will illuminate when the RAM BANK is being accessed. IC4 (4528) and TR5 stretch the enable pulse to approximately 1 second to allow proper illumination of the LED.

8.7 The I²C Bus

Communication between the TCC and the Receiver and Exciter is via an I²C (Inter-Integrated Circuit) bus. This is a two wire serial bus consisting of serial data (SDA) and serial clock (SCL). Each device on the bus is recognised by a unique address, and can operate as either a transmitter or receiver depending on its function. The TCC can send a number of commands to the SPU in the Exciter and Receiver modules, and the SPUs can respond with various messages. A list of the information sent on the I²C bus is shown below.

8.7.1 Commands

Program Synthesizer Frequency	Select FM or LM modulation schemes (for Multimode systems)
Select Transmit or Receive mode	Select Speech or Data modes
Open and Close Mute	Calibrate amplifier
Set Squelch level	Set FFSR threshold
Turn pilot pumping on and off	Adjust Transmit Power
Set FFSK modulation level	Read SPU Status info
Read SPU software version	

8.7.2 Responses

Locked onto pilot tone indicator	Receive Signal Strength Indicator (RSSI)
Squelch State indicator	PA over temperature warning
PA stability failure	PA reverse power warning
SPU Software Version number	Rx synthesizer out of lock
I ² C error	Tx synthesizer out of lock
Tx low forward power	

These commands and responses allow complete software control of the radio equipment.



9. Commissioning

Note: Please read this section at least once before referring to the following two sections.

As a **primary characteristic** Linear Modulation (LM) is a modulation technique used for placing intelligence in the form of speech or digital signalling (data) onto a radio frequency (RF) carrier for transmission over a wireless path in the same way that Amplitude Modulation (AM), Frequency Modulation (FM) and Single Side Band (SSB) are modulation techniques for the same purpose. As with AM, FM or SSB, LM can be used at any radio frequency allocation from VLF to microwave. LM can operate in allocations with defined channelisation, such as the mobile radio bands, or on allocations without channelisation.

In radio frequency terms LM has characteristics similar to, or identical with, AM or FM.

9.1 Range

As with AM or FM transmissions the range of LM transmissions is largely defined by the coverage area characteristics (antenna height and terrain). The higher the antenna and the flatter the terrain the greater the range.

For an LM system range will be comparable to that experienced in an equivalent AM or FM system.

9.2 Transmission Losses

Between the output of an LM transmitter used as a repeater and the antenna is, at minimum, a transmission line and a duplexer and usually some form of transmitter combining. The combining and the transmission line introduce attenuation of the signal which is a variable quantity defined by frequency band, the length of the transmission line, the number of transmitters being combined and the transmit/receive spacing. Between the transmitter antenna and the remote receiver antenna there also exists the free space and obstruction losses.

For an LM system these losses are identical to those experienced in an AM or FM system.

9.3 Receiver Losses

The receive path losses are a combination of the free space loss and the transmission line, duplexer losses and obstruction losses.

For an LM system these losses are identical to those experienced in an AM or FM system.



9.4 Reciprocity

For optimum operation of any mobile radio system, the signal that the mobile receives from the repeater should be similar in strength to the signal received by the repeater from the mobile. This is known as reciprocity.

The effect of non-reciprocity on an LM system is identical to that experienced in an AM or FM system.

10. Simplified On-Site Testing

10.1 Test Equipment

RF Test Set	HP 8920B with ITU psophometric filter option. Rohde and Schwarz CMS 50
Through Line Power Meter (PEP)	Bird 4381 or similar (with 100 W or 25 W PEP range plug in and suitable attenuator)
Special audio test cable	See figure 10-1 below.
'N' Type plug to TNC plug co-axial cable	

Note 1. The HP 8920A or B model RF test set is not optimised for LM measurement but *can* provide acceptable field results.

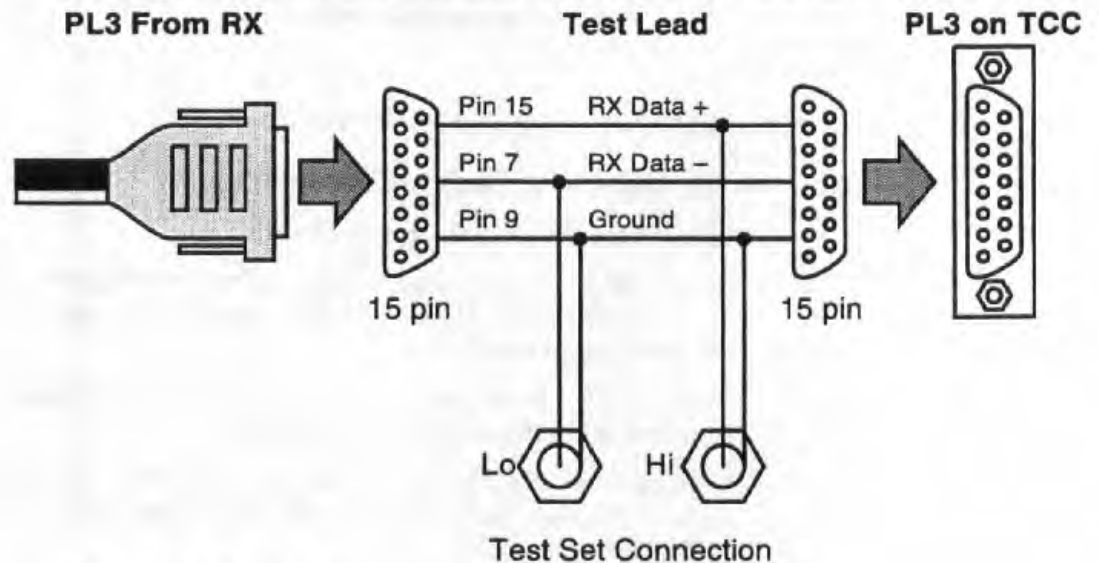

Figure 10-1 Test Lead Schematic.

10.2 Frequency Reference

Connect one of the outputs of the Repeater Frequency Standard to the external 10 MHz reference input on the RF Test Set, and set to external standard.



10.3 Receiver Sensitivity Tests

10.3.1 Setting up the Equipment

These are used to test the receiver SINAD performance for each channel and to test the site receiver splitter and amplifier.

Set up the test equipment as shown in Figure 10-2 below.

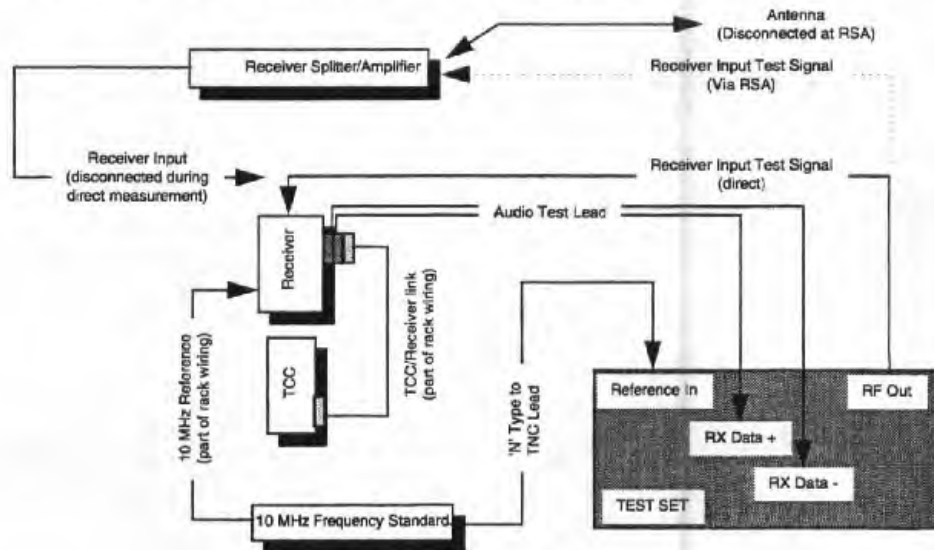

Figure 10-2 Receiver test set up for simplified site testing.

10.3.2 Measuring Receiver Sensitivity

- ◆ Start at top channel shelf in the rack.
- ◆ Switch off all channel power supplies (but **not** frequency standard or SCI). Unplug all TCC connectors (see Fig. 6-3 on page 6-5 for connectors and locations).
- ◆ Undo knurled front panel fixing screws and withdraw channel TCC from the rack. Remove TCC access plate.
- ◆ Note position of SIO address (top two rotary DIL switches) and channel number (lower three switches). Channel 001 is 221.0025 MHz, steps are 5 kHz.

Switches A and B

- ◆ Show the SIO address of the TCC card
- ◆ The range is 00 to 31. Each card has a unique address. Every card **must** have a different address.
- ◆ The channel that is designated control channel by the system control interface takes on the 'soft' address 00 during normal operation, no matter what its "hard" address is set to. Setting a TCC to SIO bus address 00 however locks the control channel to that card.

Switches C, D and E

- ◆ These set the channel number.
- ◆ Actual FCC channel frequencies can be found in section 12, Channel Frequencies.

N.B. On multi site systems channel allocation is signalled by use of the SIO bus numbering. Therefore the same SIO bus number/channel number relationship must be maintained across all sites to ensure that the same channel is selected at all sites e.g. if channel 19 is the second physical channel in the rack on five interconnected sites and the SIO bus number is 02 on one site then it must be set to 02 on all sites.

Figure 10-3 TCC Internal Controls - 1

1. Set the top two rotary DIL switches in the TCC to test mode (90).
2. Return TCC to the rack and reconnect all connectors except the RF input and PL3.
3. Connect HP 8920B test set output to receiver input.
4. Connect the special audio test cable 15 way D-Type back-to-back connector to TCC connector PL3 and connect plug PL3 to the test lead. The test lead is now in-line with the connections between the TCC and the receiver). Connect the test lead BNC connectors to the HP 8920B test set Hi and Lo inputs (Rx Data+ to Hi, Rx data- to Lo).
5. Switch channel power on.
6. Set mode switch to 1, receive only. See following figure 10-4:



TCC Internal Controls

Remove access cover to expose 5 rotary DIL switches on main PCB immediately behind display board.

Switches A and B

- ◆ If set to 90 selects 'transmitter test' modes.
- ◆ The particular test mode is selected using the MODE switch and the selection appears on the display e.g. 2--

Transmitter Test Modes

1. Tx off: receives only
2. Pilot tone: transmits only pilot tone
3. Two tone: transmits pilot tone with two modulating tones
4. Single tone: transmits pilot tone with one modulating tone
5. External: Transmits pilot tone and externally provided modulation

Notes

- ◆ If pilot pumping is selected in normal mode, it will be active in test mode
- ◆ The transmitter can be keyed/dekeyed using the up/down switch on the TCC front panel
- ◆ When in transmit a third dash appears on the display e.g. 2---

Figure 10-4 TCC Internal Controls - 2

Using the TCC front panel switches and display set the squelch level to permanently open (see figure 10-5 and following table).

Trunking Channel Controller. Indicators and Switches

Squelch Set

- ◆ Push mode switch down once
- ◆ Display will show '5-xx'
- ◆ xx is current squelch setting value
- ◆ Use up / down switch to change setting
- ◆ Range is 0 to 63. Default is 07

FFSR Threshold Set

- ◆ Push mode switch down twice
- ◆ Display will show '5-xx'
- ◆ xx is FFSR threshold setting value
- ◆ Use up / down switch to change setting
- ◆ Range is 0 to 63. Default is 32
- ◆ The FFSR threshold value is not normally changed during commissioning

Figure 10-5 TCC Indicators and Switches

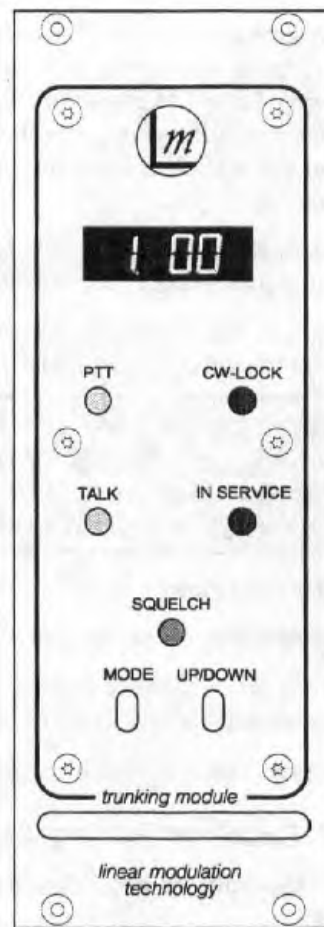

Figure 10-6 TCC Front Panel

Typical Squelch Control Settings

TCC Display Value	Open at dBm	Close at dBm
11	-114	-137
12	-112	-126
13	-111	-121
14	-110	-118
15	-109	-114
16	-107	-113
17	-105	-111
18	-105	-110
19	-103	-109
20	-103	-108
21	-102	-108
22	-101	-106
23	-99	-105

1. Set RF output mode on test set to AM
2. Set test set output frequency to 10 kHz below the receive frequency of the channel under test.
3. Set audio generator 1 to 10.000 kHz, 25 % modulation level.



4. Set audio generator 2 to 10.950 kHz, 75 % modulation level. This puts the upper sideband of the AM transmission in the pass band of the LM receiver, with two signals being detected. The LM receiver will treat the +10.000 kHz sideband as carrier/pilot tone and the +10.950 kHz sideband as a 950 Hz tone for SINAD measurement.
5. Set output level of generator to -80 dBm. The squelch LED on the TCC front panel will indicate squelch open.
6. Reduce the generator output until 12 dB SINAD is reached. This level is typically -110 dBm for a correctly functioning unit.

Note: Using the signal generator in this way the output required to produce a given SINAD is 6 dB greater than that for a directly generated signal. This is because only part of the generator output signal lies within the LM receiver passband.

7. Calibrate power level using the spectrum analyser.
8. Record the value that gave 12 dB SINAD.
9. Compare with test results if available. Acceptable range is ± 1 dB of test result or better than -106 dBm.
10. Repeat tests for each receiver in the rack.

10.3.3 Receiver Testing via Splitter/Amplifier

To test the splitter/amplifier and receiver combination proceed as follows:

1. Connect the HP 8920B test set output to the antenna connector of the antenna combining equipment.
2. Repeat the tests described above for direct connection and record the results.

The difference between the results for direct connection and connection through the duplexer/splitter/amplifier combination is the loss produced by the combination itself. This should be no more than 6dB (usually much better) and should be constant for all the receivers to ± 1 dB.

10.3.4 Returning Equipment to Operation

1. Reset SIO bus addresses to recorded value on the top two switches.
2. Switch off the channel power supply.
3. Unplug all TCC rear connectors.
4. Remove test RF and audio leads.
5. Withdraw the TCC from the rack.
If no further testing is to be carried out (e.g. transmitter tests) replace the TCC access plate and re-install into the rack, tightening the module front panel retaining screws by hand only. Otherwise leave the access plate off.
6. Re-connect TCC cables and receiver cables (see figure 6-3 on page 6-5).
7. Switch on channel power supply.

8. Using TCC front panel switches and display, set the squelch level to 14 or, on sites with a high noise floor, to a greater value which ensures that the squelch closes when no signal is present.

When all receivers have been tested, TCCs returned to the rack and all cables re-connected **and if no transmitter testing is to be carried out** then switch all channel supplies back on. Start at the top channel shelf and work downwards. This ensures that the first channel shelf becomes the control channel. If transmitter testing is to be carried out then follow the instructions below.

10.4 Transmitter Tests

10.4.1 Transmitter Testing, Direct Connection

1. Start at top channel shelf in the rack.
2. Switch off all channel power supplies (but **not** frequency standard or SCI). Unplug all TCC connectors (see figure 6-3 for connectors and locations).
3. Undo knurled front panel fixing screws and withdraw channel TCC from the rack. Remove TCC access cover.
4. Note position of SIO address (top two rotary DIL switches) and channel number (lower three switches). Channel 001 is 221.0025 MHz, steps are 5 kHz.
5. Set top two rotary DIL switches to test mode (90) and return TCC to rack.
6. Re-connect TCC cables (see figure 6-3 on page 6-5 for connector locations).
7. Connect the through line PEP wattmeter between the transmitter and the antenna combiner.
8. Switch the power supply on.
9. Set transmitter to two tone test (see figure 10-4 above).
10. Using up/down switch key on the transmitter.
Meter should read $22.5\text{ W} \pm 2.5\text{ W}$ ($90\text{ W} \pm 10\text{ W}$ for 100 W PA).
(Make sure that correct slug is used in the power meter to give required accuracy). Be sure to take into account local conditions (antenna gain etc.) that could exceed licence requirements.
11. Record the value.
12. Compare with previous test results, if available. Acceptable range is within $\pm 1\text{ dB}$ of last test result.
13. Adjust RF output power out, if necessary, to achieve 25 W (or 100 W) PEP. Acceptable range of TCC display to achieve this is 46 to 56. See following figure 10-7 for the method of adjustment.

Warning: Transmitter may go unstable if the power level is set incorrectly.

**TCC Internal Controls - Transmitter Adjustment****Switches A and B**

- ◆ Set switches to 91 to select transmitter power adjust mode
- ◆ When 91 is selected the transmission is continuous two tone mode when keyed on
- ◆ The power level is adjusted using the mode switch and the display. Minimum output is 01, maximum is 63
- ◆ The transmitter can be keyed/dekeyed using the up/down switch on the TCC front panel
- ◆ De-key transmitter.
- ◆ Set wattmeter to return power.
- ◆ Re-key transmitter.
- ◆ Check return power.
- ◆ VSWR must be 1.1:1 or better.
- ◆ If worse then combiner may need to be re-tuned to achieve 1.1:1.
- ◆ Repeat tests for each transmitter in the rack.

Figure 10-7: TCC Internal Controls, Transmitter Adjustment

10.4.2 Transmitter Testing, Connection via Transmitter Combiner

This test measures the loss through the duplexer and combining circuitry.

The loss will depend on the particular combining configuration used. A copy of the factory test results is required for comparison purposes.

1. Connect power meter between duplexer output and antenna feed.
2. Key transmitter.
3. Record meter reading.
4. Compare with previous test results, if available. Acceptable range is ± 1 dB of test result.
5. De-key transmitter.
6. Set wattmeter to measure return power.
7. Check that return power is within specification and that VSWR is 1.1:1 or better.
8. If worse than 1.1:1 then antenna installation should be checked.
9. Repeat the tests for each transmitter in the rack.

On completion of all transmitter testing:

1. Reset TCC SIO bus address to recorded value using the top two switches.
2. Switch off channel power supply.
3. Unplug all TCC rear connectors.
4. Remove RF and audio leads (if used).
5. Withdraw TCC from rack.



6. Replace TCC access covers and re-install into rack, tightening knurled retaining screws by hand only.
7. Re-connect TCC cables (see Fig. 6-3 on page 6-5 for connector locations).

10.4.3 Returning Equipment to Operation

When all transmitters have been tested, TCCs returned to rack, all cables reconnected and if no receiver testing is to be carried out then switch all channel power supplies back on. Start at the channel shelf at the top of the rack and work downwards. This ensures that the first channel shelf becomes the control channel. If receiver testing is to be carried out then follow the receiver testing instruction above.

10.4.4 Carrier Wave Identification (CWID)

In the US, it is a requirement that radio transmissions carry a CWID broadcast at least every 30 minutes. The CWID unit is fitted to the lowest frequency channel of the allocated channel set.

See your dealer for additional information.



11. Comprehensive On-Site Testing

IMPORTANT: The Test Equipment and Equipment under test should be powered up for at least 15 minutes before testing is commenced. This allows the frequency standard and oscillators to stabilise at their correct frequencies.

11.1 Test Equipment

RF Signal Generators (2 off)	HP8657A
RF Spectrum Analyzer	HP8560E
Audio Analyzer	HP8903B
Power Meter (PEP) 100 W forward	Bird 4381 (100 W insert)
Power Meter (PEP) 25 W forward	Bird 4381 (25 W insert)
Frequency Counter	HP5385A, OPT004
3 dB Splitter	Mini Circuits 2FSC-2-1
30 dB RF attenuator	150 W rating (100 W channel) 50 W rating (25 W channel)
Special audio test cable	See figure 10-1.

11.2 Frequency Standard

Note: Do not carry out this test unless the frequency counter is known to be accurate to better than 1 part in 10^6 .

Connect one of the outputs of the Frequency Standard to the Frequency Counter and check that the frequency is $10.000000 \text{ MHz} \pm 1 \text{ Hz}$. If necessary, adjust the frequency using the **FREQ. ADJUST** potentiometer located on the rear panel of the unit.

A better check would be to connect a known good frequency standard and the unit under test to the X and Y inputs on an oscilloscope to create a Lissajous figure. The frequency of the test unit can be adjusted until the figure is approximately stationary.

11.3 Test Modes

The TCC provides a number of test modes to facilitate testing of the transmitter and receiver modules. These are selected by setting the SIO bus address to specified test codes using the rotary BCD switches (A and B, the top two switches on the TCC PCB).



Note: See section 10 on page 10-1 of this manual for more detailed information on TCC settings and how they are made.

11.3.1 Transmit Preamble

- ◆ Set SIO bus switches to 96.

The FFSK modem continuously transmits 101010...

The display shows all digits scrolling '1010'.

11.3.2 Transmitter Test Modes

Note: See section 10 on page 10-1 of this manual for more detailed information on TCC settings and how they are made.

Set SIO bus switches to 90.

11.3.3 Transmitter Power Adjust

Set SIO bus switches to 91.

This mode transmits a two-tone signal, and allows fine adjustment of the transmit power.

WARNING: Increasing the power level above the rated value may cause the PA output waveform to become distorted, and result in wideband emissions outside the conditions of the licence.

The transmitter is keyed up and down using the MODE switch.

The power level is adjusted using the UP/DOWN switch.

The default value for the power level is 32, which corresponds to rated power out. The power output is given by:

$$Power (Watts) \approx Nominal Power \times \left(\frac{Selected Value + 11}{64} \right)^2$$

11.4 Receiver Tests

11.4.1 Connections

1. Connect the audio outputs (RX-IN Pins 15 and 7) of the receiver module to an Audio Analyzer. Your special test lead (see section 10) can be used for this.
2. Connect the external standard inputs of the RF Signal Generators to two free outputs on the Shelf Frequency Standard.
3. Connect the outputs of two RF Signal Generators together with a 3 dB splitter.
4. Connect the output of the splitter into the antenna connector of the receiver module.
5. Set the Audio Analyzer to measure SINAD at 1 kHz with a CCITT (ITU) psophometric filter.



11.4.2 Ultimate SINAD Test

1. Set the frequency of one generator to the frequency of the centre selected channel (pilot tone) with an amplitude of -66 dBm.
2. Set the frequency of the other signal generator to 950 Hz above the pilot frequency (to give a 1 kHz tone), with an amplitude of -57 dBm.
3. Check that the SINAD is more than 36 dB.

11.4.3 Sensitivity Test

1. Decrease the output levels of the two signal generators to obtain a 12 dB SINAD, keeping the pilot tone 9 dB below the test tone.
2. The quoted sensitivity of the receiver is -115 dBm for a 12 dB SINAD. The test tone level should be -111 dBm, allowing 3 dB for loss through the coupler, and 1 dB for the connecting leads.
3. Check at least channels 001 (221.0025 MHz), 101 (221.5025 MHz), and 200 (221.9975 MHz) to exercise the full frequency range of the receiver.

11.5 Transmitter Tests

11.5.1 Connections

1. Connect the antenna output of the PA module to a suitably rated through-line power meter and 30 dB attenuator.
2. Connect the output of the power meter to a 30 dB, 100 W attenuator. Do not transmit without a suitable load connected to the antenna line.
3. Connect the output of the attenuator to a Spectrum Analyzer.

The Exciter has a built in signal generator to make transmitter tests easier. Alternatively, an external audio signal generator can be connected to the audio input (TX-IN Pins 14 and 6) of the Exciter module.

The 10 MHz reference inputs of the Signal Generators and Spectrum Analyzer should all be connected to the Frequency Standard.

11.5.2 Spectrum Analyzer Set-up

Set up the spectrum analyzer as follows:

◆ Centre Frequency	Nominal Channel Frequency
◆ Span	20 kHz
◆ Video Bandwidth	100 Hz
◆ Resolution Bandwidth	100 Hz
◆ Reference Level	+44 dBm (+50 dBm for 100 W PA)
◆ Reference Offset Level	+30 dB

The analyzer should be powered up 15 minutes before the tests to make sure that it is stable.



11.5.3 Stability: Pilot Only Test

1. Use the MODE switch on the front of the TCC to select the pilot-only test.
2. Key the transmitter up using the UP/DOWN switch. The Tx LED on the PA will illuminate to indicate that the channel is transmitting.
3. Check that a single peak is observed on the spectrum analyzer, and that its frequency is steady, and within 100 Hz of the correct value. Other peaks on the display should be at least 60 dB down on the pilot tone, as shown in the diagram below:

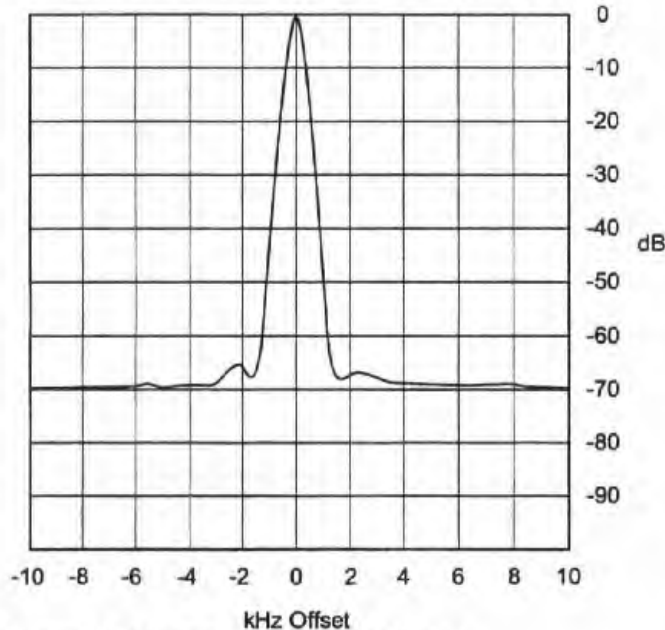

Figure 11-1: Transmitter Pilot Tone Signal

4. Make sure that peaks other than the main output, are at least 60 dB down.

11.5.4 Linearity: Two Tone Test

In this test, the power can be measured with an average power meter, and scaled by a factor of 2.8 (4.5 dB) to give the PEP value. A diode based wattmeter is not suitable for this test. If a more accurate value is required, the spectrum analyzer should be used.

1. Use the MODE switch to select the two tone test, and re-key the transmitter.
2. Measure the Peak Envelope Power (PEP), and check that it is 22.5 W ± 2.5 W (90 W ± 10 W for 100 W PA).
3. Check that the display on the spectrum analyzer is similar to that shown below:

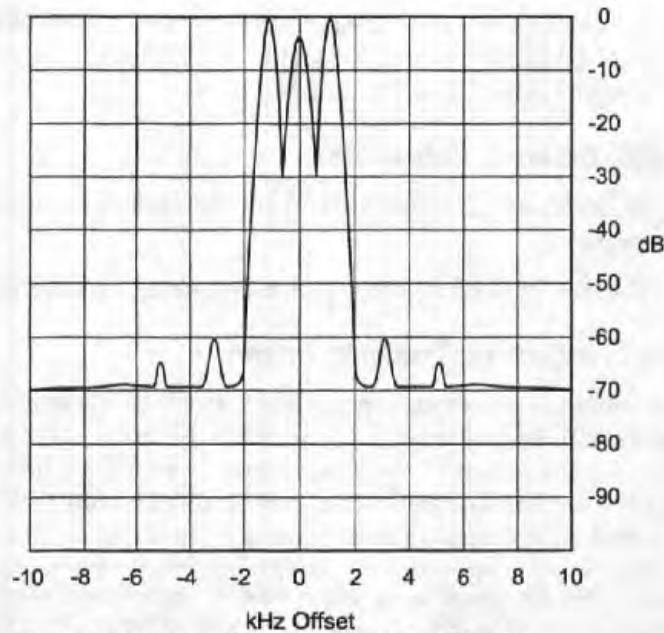

Figure 11-2: Transmitter Two Tone Test Signal

4. Make sure that any other peaks are at least 61 dB (67 dB for 100 W PA) down on the pilot tone.

11.5.5 Image Suppression: One Tone Test

1. Use the MODE switch to select the one tone test, and re-key the transmitter.
2. Check that the display on the spectrum analyzer is similar to that shown below, and that the tone image is suppressed by more than 30 dB, as shown below:

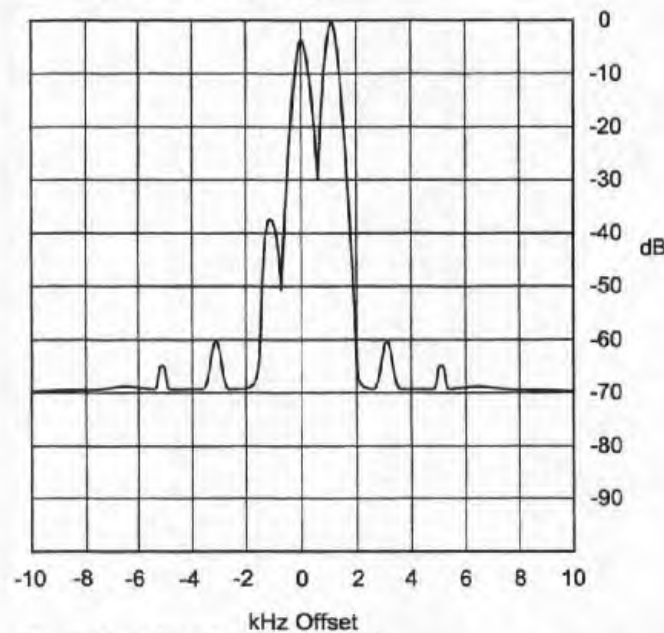

Figure 11-3: One Tone Test Signal

3. Make sure that any other peaks are at least 45 dB down on the pilot tone.
4. Turn off the transmitter using the UP/DOWN switch.



5. Repeat the tests on at least channels 001 (220.0025 MHz), 101 (220.5025 MHz), and 200 (220.9975 MHz) to exercise the full frequency range of the transmitter.

11.5.6 External Signal Test

1. Inject the desired test signal into the audio input of the Exciter module.
2. Use the MODE key to select a test using an external signal source.

11.5.7 Adjusting Transmit Power

The transmit power can be adjusted around its nominal value to meet specific site engineering requirements. Normally this will be used for reducing the power of the transmitter to minimise interference. It is possible to increase the output power slightly, but this is only intended as a fine adjustment to compensate for manufacturing variations.

Note: The transmitters must not be operated at power levels above their rated power levels (100 W PEP / 25 W PEP).

1. Put the TCC into Power Adjust mode and key up the transmitter.
2. Adjust the power level to the required value, while monitoring the output of the PA on a spectrum analyzer to ensure that it remains stable.



12. Channel Frequencies

Channel	Base Rx	Base Tx	Channel	Base Rx	Base Tx	Channel	Base Rx	Base Tx	Channel	Base Rx	Base Tx
1	220.0025	221.0025	51	220.2525	221.2525	101	220.5025	221.5025	151	220.7525	221.7525
2	220.0075	221.0075	52	220.2575	221.2575	102	220.5075	221.5075	152	220.7575	221.7575
3	220.0125	221.0125	53	220.2625	221.2625	103	220.5125	221.5125	153	220.7625	221.7625
4	220.0175	221.0175	54	220.2675	221.2675	104	220.5175	221.5175	154	220.7675	221.7675
5	220.0225	221.0225	55	220.2725	221.2725	105	220.5225	221.5225	155	220.7725	221.7725
6	220.0275	221.0275	56	220.2775	221.2775	106	220.5275	221.5275	156	220.7775	221.7775
7	220.0325	221.0325	57	220.2825	221.2825	107	220.5325	221.5325	157	220.7825	221.7825
8	220.0375	221.0375	58	220.2875	221.2875	108	220.5375	221.5375	158	220.7875	221.7875
9	220.0425	221.0425	59	220.2925	221.2925	109	220.5425	221.5425	159	220.7925	221.7925
10	220.0475	221.0475	60	220.2975	221.2975	110	220.5475	221.5475	160	220.7975	221.7975
11	220.0525	221.0525	61	220.3025	221.3025	111	220.5525	221.5525	161	220.8025	221.8025
12	220.0575	221.0575	62	220.3075	221.3075	112	220.5575	221.5575	162	220.8075	221.8075
13	220.0625	221.0625	63	220.3125	221.3125	113	220.5625	221.5625	163	220.8125	221.8125
14	220.0675	221.0675	64	220.3175	221.3175	114	220.5675	221.5675	164	220.8175	221.8175
15	220.0725	221.0725	65	220.3225	221.3225	115	220.5725	221.5725	165	220.8225	221.8225
16	220.0775	221.0775	66	220.3275	221.3275	116	220.5775	221.5775	166	220.8275	221.8275
17	220.0825	221.0825	67	220.3325	221.3325	117	220.5825	221.5825	167	220.8325	221.8325
18	220.0875	221.0875	68	220.3375	221.3375	118	220.5875	221.5875	168	220.8375	221.8375
19	220.0925	221.0925	69	220.3425	221.3425	119	220.5925	221.5925	169	220.8425	221.8425
20	220.0975	221.0975	70	220.3475	221.3475	120	220.5975	221.5975	170	220.8475	221.8475
21	220.1025	221.1025	71	220.3525	221.3525	121	220.6025	221.6025	171	220.8525	221.8525
22	220.1075	221.1075	72	220.3575	221.3575	122	220.6075	221.6075	172	220.8575	221.8575
23	220.1125	221.1125	73	220.3625	221.3625	123	220.6125	221.6125	173	220.8625	221.8625
24	220.1175	221.1175	74	220.3675	221.3675	124	220.6175	221.6175	174	220.8675	221.8675
25	220.1225	221.1225	75	220.3725	221.3725	125	220.6225	221.6225	175	220.8725	221.8725
26	220.1275	221.1275	76	220.3775	221.3775	126	220.6275	221.6275	176	220.8775	221.8775
27	220.1325	221.1325	77	220.3825	221.3825	127	220.6325	221.6325	177	220.8825	221.8825
28	220.1375	221.1375	78	220.3875	221.3875	128	220.6375	221.6375	178	220.8875	221.8875
29	220.1425	221.1425	79	220.3925	221.3925	129	220.6425	221.6425	179	220.8925	221.8925
30	220.1475	221.1475	80	220.3975	221.3975	130	220.6475	221.6475	180	220.8975	221.8975
31	220.1525	221.1525	81	220.4025	221.4025	131	220.6525	221.6525	181	220.9025	221.9025
32	220.1575	221.1575	82	220.4075	221.4075	132	220.6575	221.6575	182	220.9075	221.9075
33	220.1625	221.1625	83	220.4125	221.4125	133	220.6625	221.6625	183	220.9125	221.9125
34	220.1675	221.1675	84	220.4175	221.4175	134	220.6675	221.6675	184	220.9175	221.9175
35	220.1725	221.1725	85	220.4225	221.4225	135	220.6725	221.6725	185	220.9225	221.9225
36	220.1775	221.1775	86	220.4275	221.4275	136	220.6775	221.6775	186	220.9275	221.9275
37	220.1825	221.1825	87	220.4325	221.4325	137	220.6825	221.6825	187	220.9325	221.9325
38	220.1875	221.1875	88	220.4375	221.4375	138	220.6875	221.6875	188	220.9375	221.9375
39	220.1925	221.1925	89	220.4425	221.4425	139	220.6925	221.6925	189	220.9425	221.9425
40	220.1975	221.1975	90	220.4475	221.4475	140	220.6975	221.6975	190	220.9475	221.9475
41	220.2025	221.2025	91	220.4525	221.4525	141	220.7025	221.7025	191	220.9525	221.9525
42	220.2075	221.2075	92	220.4575	221.4575	142	220.7075	221.7075	192	220.9575	221.9575
43	220.2125	221.2125	93	220.4625	221.4625	143	220.7125	221.7125	193	220.9625	221.9625
44	220.2175	221.2175	94	220.4675	221.4675	144	220.7175	221.7175	194	220.9675	221.9675
45	220.2225	221.2225	95	220.4725	221.4725	145	220.7225	221.7225	195	220.9725	221.9725
46	220.2275	221.2275	96	220.4775	221.4775	146	220.7275	221.7275	196	220.9775	221.9775
47	220.2325	221.2325	97	220.4825	221.4825	147	220.7325	221.7325	197	220.9825	221.9825
48	220.2375	221.2375	98	220.4875	221.4875	148	220.7375	221.7375	198	220.9875	221.9875
49	220.2425	221.2425	99	220.4925	221.4925	149	220.7425	221.7425	199	220.9925	221.9925
50	220.2475	221.2475	100	220.4975	221.4975	150	220.7475	221.7475	200	220.9975	221.9975



13. Base Station 5-Channel 25/100 W

Contents

General Assemblies	13-3
Base Station.....	13-3
Module Parts List	13-5
Looms	13-7
Sub-Assembly E/B Looms	13-7
Channel 1 E/B 55 Loom.....	L033BEL55XEA0 13-7
Channel 2 E/B 80 Loom.....	L033BEL80XEA0 13-7
Channel 3 E/B 101 Loom.....	L033BEL101EA0 13-7
Channel 4 E/B 123 Loom.....	L033BEL123EA0 13-7
Channel 5 E/B 145 Loom.....	L033BEL145EA0 13-7
F/S-E/B 68 Loom.....	L033BEL68XEA0 13-7
PSU - Chassis E/Loom.....	L033CEL47EXA0 13-7
SCI E/B 198 Loom.....	L033BEL198EA0 13-7
Channel Looms	13-8
F/S73-Channel 1 Loom	L033BFS73XEA0..... 13-8
F/S76-Channel 1 Loom	L033BFS76XEA0..... 13-8
F/S98-Channel 2 Loom	L033BFS98XEA0..... 13-8
F/S102-Channel 2 Loom	L033BFS102XEA0..... 13-8
F/S123-Channel 3 Loom	L033BFS123XEA0..... 13-8
F/S128-Channel 3 Loom	L033BFS128XEA0..... 13-8
F/S149-Channel 4 Loom	L033BFS149XEA0..... 13-8
F/S154-Channel 4 Loom	L033BFS154XEA0..... 13-8
F/S175-Channel 5 Loom	L033BFS175XEA0..... 13-8
F/S177-Channel 5 Loom	L033BFS177XEA0..... 13-8
CHL-Circulator Loom.....	L033BLB500EA1..... 13-10
CHL1/5-Duplexer Loom	L033BLB200EA1..... 13-11
Pillar-B/Frame E/B.....	L033BEL13BEA0 13-12
Top Frame-Pillar E/B	L033BEL26PEA0 13-12
SCI to Channel SIO Loom.....	L033BSCICIOA0 13-13
Top Panel-Top Frame E/B.....	L033BEL26TEA0 13-14
S/Panel-B/Frame E/B	L033BEL26BEA0 13-14
Distribution Block Earth.....	L033BSDISTEA1..... 13-15

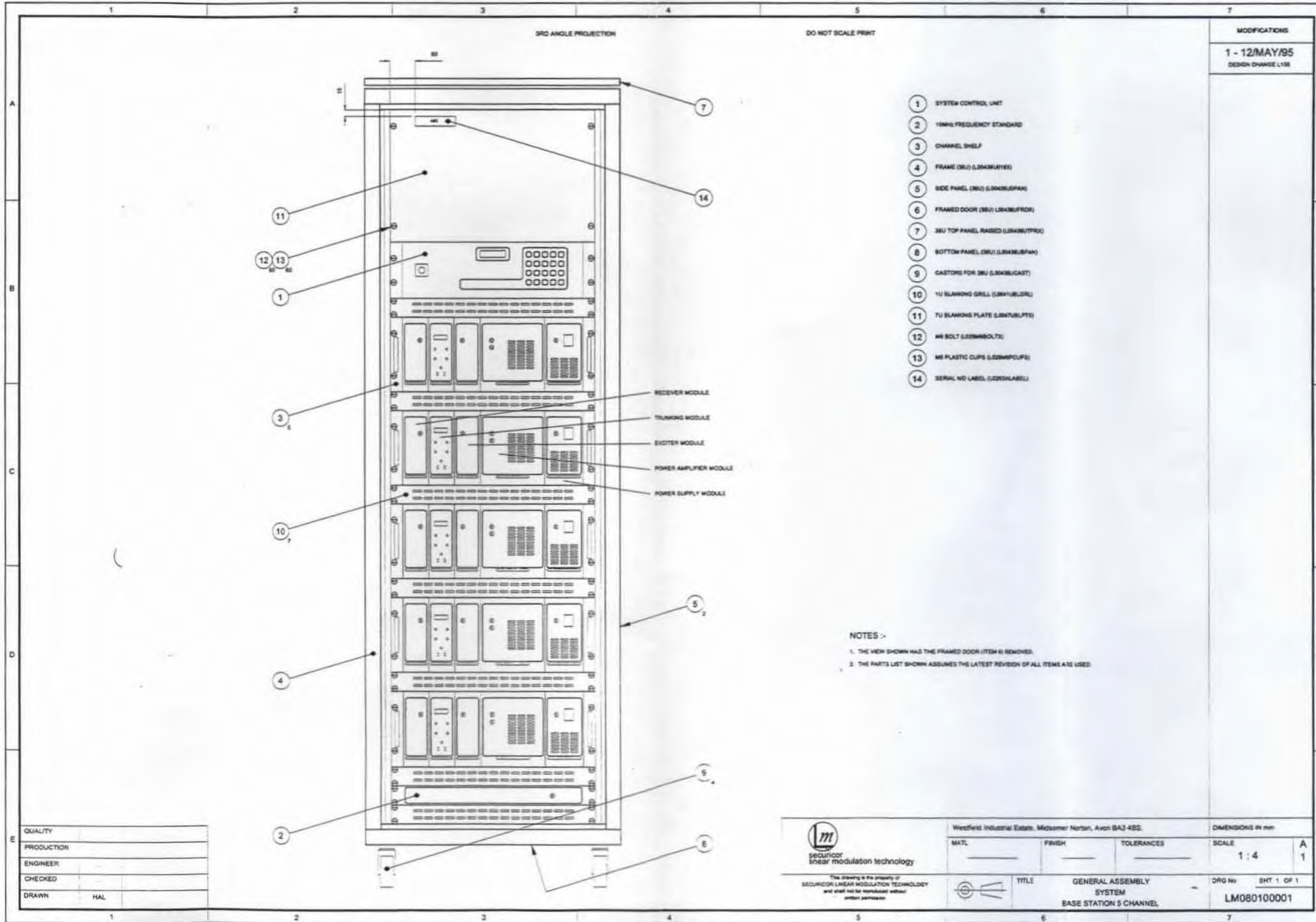



Module Parts List

All Base Station 5-Channel Chassis

Document No: LM030300013

Issue 1.0

Reference	Description	Stock Number
7	1U BLANKING GRILL	L0041UBLGR1A0
1	FRAME (38U)	L00438U019XA0
1	BOTTOM PANEL (38U)	L00438UBPANAO
4	CASTORS FOR 38U	L00438UCASTAO
1	EARTH BUS BAR	L00438UEBUSAO
1	FRAMED DOOR (38U)	L00438UFRDRAO
1	SIDE PANELS (38U)	L00438USPANAO
16	SLIDE RAILS (38U)	*L00438USRLSAO*
1	TOP PANEL (38U)	L00438UTPANAO
1	7U BLANKING PLATE	L0047UBLPTSAO
4	TRNKNG SUPPORT BAR	L004BSU1507A1
1.6	RAIL ASSEMBLY KIT	L004RAILKITA0
1	M5 YELLOW RING CRIMP	L013M5YCRIMAO
1	SERIAL N/D LABEL	L026SNLABELBO
42	M5X12 PAN HEAD TORX BZCP	L0295P12MMTA0
5	M6X12 PAN HEAD POZI BZCP	L0296P12MMPAO
2	M6X40 PAN HEAD POZI BZCP	L0296X40MMPAO
33	M5 NUT BZCP	L029M5NUTXXAO
42	M5 PLAIN WASHER	L029M5WASHPAO
42	M5 SHAKEPROOF WASHER	L029M5WASHSAO
64	M6 BOLT	L029M6BOLTXXAO
64	M6 CAGE NUT	L029M6NUTSXXAO
7	M6 NUT BZCP	L029M6NUTXXAO
64	M6 PLASTIC CUPS	L029M6PCUPSAO
14	M6 PLAIN WASHER	L029M6WASHPAO
14	M6 SHAKEPROOF WASHER	L029M6WASHSAO
1	CHANNEL 3 E/B 101 LOOM	L033BEL101EAO
1	CHANNEL 4 E/B 123 LOOM	L033BEL123EAO
4	PILLAR-E/F/FRAME E/B	L033BEL13BEAO
1	CHANNEL 5 E/B 145 LOOM	L033BEL145EAO
1	SCU E/B 198 LOOM	L033BEL198EAO
2	S/PANEL-E/F/FRAME E/B	L033BEL26BEAO
1	TOP FRAME-PILLAR E/B	L033BEL26PEAO
1	TOP PANEL-TOP FRAME E/B	L033BEL26TEAO
1	CHANNEL 1 E/B 55 LOOM	L033BEL55XEAO
1	F/S-E/B 68 LOOM	L033BEL68XEAO
1	CHANNEL 2 E/B 80 LOOM	L033BEL80XEAO
1	F/S102-CHANNEL 2 LOOM	L033BFS102EAO
1	F/S123-CHANNEL 3 LOOM	L033BFS123EAO
1	F/S128-CHANNEL 3 LOOM	L033BFS128EAO
1	F/S149-CHANNEL 4 LOOM	L033BFS149EAO
1	F/S154-CHANNEL 4 LOOM	L033BFS154EAO
1	F/S175-CHANNEL 5 LOOM	L033BFS175EAO
1	F/S177-CHANNEL 5 LOOM	L033BFS177EAO
1	F/S73-CHANNEL 1 LOOM	L033BFS73XEAO



1	F/S76-CHANNEL 1 LOOM	L033BFS76XEA0
1	F/S98-CHANNEL 2 LOOM	L033BFS98XEA0
5	CHL1/5-DUPLEXER LOOM	L033BLB200EA1
5	CHL-CIRCULATOR LOOM	L033BLB500EA1
1	MAINS 100-CHANNEL 2 LOOM	L033BMS100EA0
1	MAINS 125-CHANNEL 3 LOOM	L033BMS125EA0
1	MAINS 150-CHANNEL 4 LOOM	L033BMS150EA0
1	MAINS 175-CHANNEL 5 LOOM	L033BMS175EA0
1	MAINS 220-SCU LOOM	L033BMS220EA0
1	MAINS SUPPLY LOOM	L033BMS500EA0
1	MAINS 70-F/S LOOM	L033BMS70XEA0
1	MAINS 75-CHANNEL 1 LOOM	L033BMS75XEA0
1	SCU TO CHANNEL SIO LOOM	L033BSCUCIOA0
1	DISTRIBUTION BLOCK EARTH	L033BSDISTEA1
1	10WAY DISTRIBUTION 100W	L03510W100WA0
4	OPEN SLOT CABLE TRUNKING	L03538UCTRGA0
1	GROMMET	L035GROMMETA0



PROJECTION :-

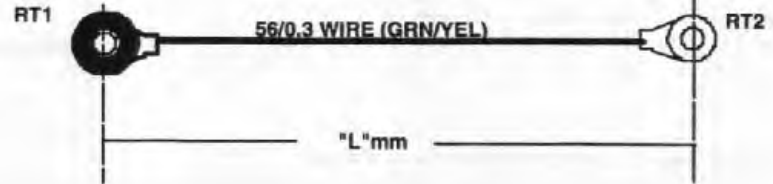

WIRE TYPE :- TRI-RATED BS6231 SIZE 56/0.3 G/Y INSULATION.
(Farnell 218-030 or equivalent).

RT1 :- M4 RING TERMINALS TYPE THOMAS AND BETTS DRC4Y.
(Farnell 209-569 or equivalent).

RT2 :- M5 RING TERMINALS TYPE THOMAS AND BETTS DRC5Y.
(Farnell 209-570 or equivalent).

CABLE DESCRIPTION	PART NUMBER	DIMENSION "L"(min)	DRAWING SUB-NUMBER
CHANNEL 1 E/B 55 LOOM	L033BEL55XEA0	550mm	9LMT0002.L01
CHANNEL 2 E/B 80 LOOM	L033BEL80XEA0	800mm	9LMT0002.L02
CHANNEL 3 E/B 101 LOOM	L033BEL101EA0	1010mm	9LMT0002.L03
CHANNEL 4 E/B 123 LOOM	L033BEL123EA0	1230mm	9LMT0002.L04
CHANNEL 5 E/B 145 LOOM	L033BEL145EA0	1450mm	9LMT0002.L05
SCU E/B 198 LOOM	L033BEL198EA0	1980mm	9LMT0002.L06
F/S-E/B 68 LOOM (See Note 1).	L033BEL68XEA0	680mm	9LMT0002.L07
PSU-CHASSIS E/LOOM	L033CEL47EXA0	470mm	9LMT0002.L08

Note 1 :- F/S-E/B 68 LOOM is unique in that it is to be fitted with 5mm Ring Terminals at both ends.

DRW:- 9LMT0004.LEB

TITLE :-

MAT :-

DRAWN :- B.PERRETT.

ISSUE :- 1.0

SUB-ASSEMBLY E/B LOOMS. (Part Numbers as above)

FIN :-

DATE :- 18.4.94.



PROJECTION :-

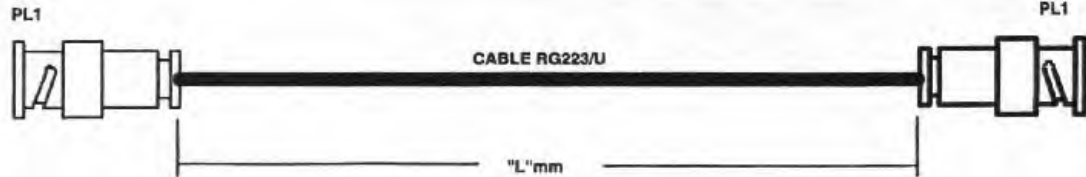
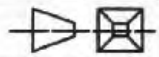

CABLE:- UR76 (Farnell 140-471) or RG223/U (or equivalent).

PL1/PL2:-BNC PLUG M/A-COM B35A70E010X99(or equivalent).

CABLE DESCRIPTION	PART NUMBER	DIMENSION "L"(min)	DRAWING SUB-NUMBER
F/S73-CHANNEL 1 LOOM	L033BFS73XEA0	730mm	8LMT0007.L01
F/S76-CHANNEL 1 LOOM	L033BFS76XEA0	760mm	8LMT0007.L02
F/S98-CHANNEL 2 LOOM	L033BFS98XEA0	980mm	8LMT0007.L03
F/S102-CHANNEL 2 LOOM	L033BFS102EA0	1020mm	8LMT0007.L04
F/S123-CHANNEL 3 LOOM	L033BFS123EA0	1230mm	8LMT0007.L05
F/S128-CHANNEL 3 LOOM	L033BFS128EA0	1280mm	8LMT0007.L06
F/S149-CHANNEL 4 LOOM	L033BFS149EA0	1490mm	8LMT0007.L07
F/S154-CHANNEL 4 LOOM	L033BFS154EA0	1540mm	8LMT0007.L08
F/S175-CHANNEL 5 LOOM	L033BFS175EA0	1750mm	8LMT0007.L09
F/S177-CHANNEL 5 LOOM	L033BFS177EA0	1770mm	8LMT0007.L10

DRW:- 8LMT0007.L01E	TITLE :- F/SXX-CHANNEL LOOMS.	MAT :-	DRAWN :- B.PERRETT.
ISSUE :- 1.0.		FIN :-	DATE :- 18.4.94.



PROJECTION :- 

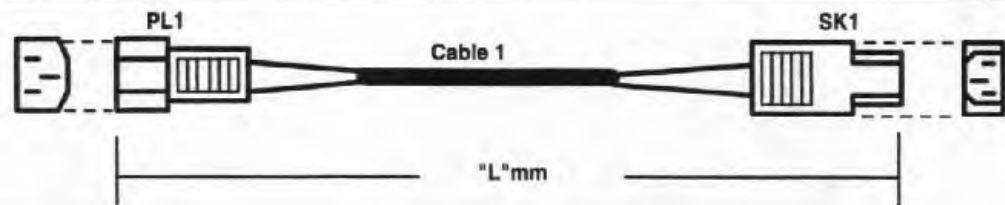

PL1 :- IEC FREE PLUG (Farnell 146-766).

SK1 :- IEC FREE SOCKET TO BS4491 (Farnell P587).

CABLE TYPE :- MAINS FLEX-3-Core 32/0.2mm (Farnell 436-719).

CABLE DESCRIPTION	PART NUMBER	DIMENSION "L"(min)	DRAWING SUB-NUMBER
MAINS 75-CHANNEL 1 LOOM	L033BMS75XEA0	750mm	9LMT0004.M01
MAINS 100-CHANNEL 2 LOOM	L033BMS100EA0	1000mm	9LMT0004.M02
MAINS 125-CHANNEL 3 LOOM	L033BMS125EA0	1250mm	9LMT0004.M03
MAINS 150-CHANNEL 4 LOOM	L033BMS150EA0	1500mm	9LMT0004.M04
MAINS 175-CHANNEL 5 LOOM	L033BMS175EA0	1750mm	9LMT0004.M05
MAINS 220-SCU LOOM	L033BMS220EA0	2200mm	9LMT0004.M06
MAINS SUPPLY LOOM	L033BMS500EA0	5000mm	9LMT0004.M07
MAINS 70-F/S LOOM	L033BMS70XEA0	700mm	9LMT0004.M08

DRW:- 9LMT0004.LMS

TITLE :-

MAT :-

DRAWN :- B.PERRETT.

ISSUE :- 1.1

5-CHANNEL MAINS LOOMS. (Part Numbers as above)

FIN :-

DATE :- 18.4.94.



PROJECTION :-

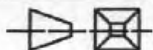

PL1



CABLE RG214/U

PL2

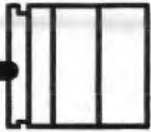

500cm

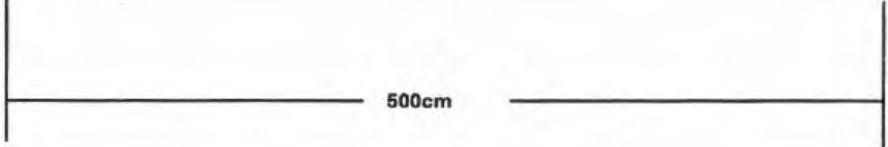

PS-

PL1/PL2 :- N-Type/PLUG M/A-COM N15A14E001X99 (FARNELL GE15015C1) (or equivalent).

CABLE:- RG214/U (or equivalent).

Note 1 :- Drawing issue raised to 1.1 because previous cable type was incorrect.

DRW:- 9LMT0004.L3E	TITLE :-	MAT :-	DRAWN :- B.PERRETT.
ISSUE :- 1.1.	CHL-CIRCULATOR LOOM. (Part L033BLB500EA0)	FIN :-	DATE :- 18.4.94.



PROJECTION :-

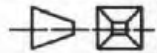

PL1



CABLE RG223/U

PL2

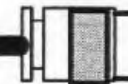

500cm

45

PL1 :- N-Type/PLUG M/A-COM N15A55E010X99 (FARNELL GE15055C10) (or equivalent).

PL2 :- TNC/PLUG M/A-COM T35A70E010X99 (FARNELL GE35870C10) (or equivalent).

CABLE:- RG223/U (or equivalent).

Note 1 :- Drawing issue raised to 1.1 because previous cable type was incorrect.

DRW:- 9LMT0004.L4E	TITLE :-	MAT :-	DRAWN :- B.PERRETT.
ISSUE :- 1.1	CHL1/5-DUPLEXER LOOM. (Part L033BLB200EA0)	FIN :-	DATE :- 18.4.94.

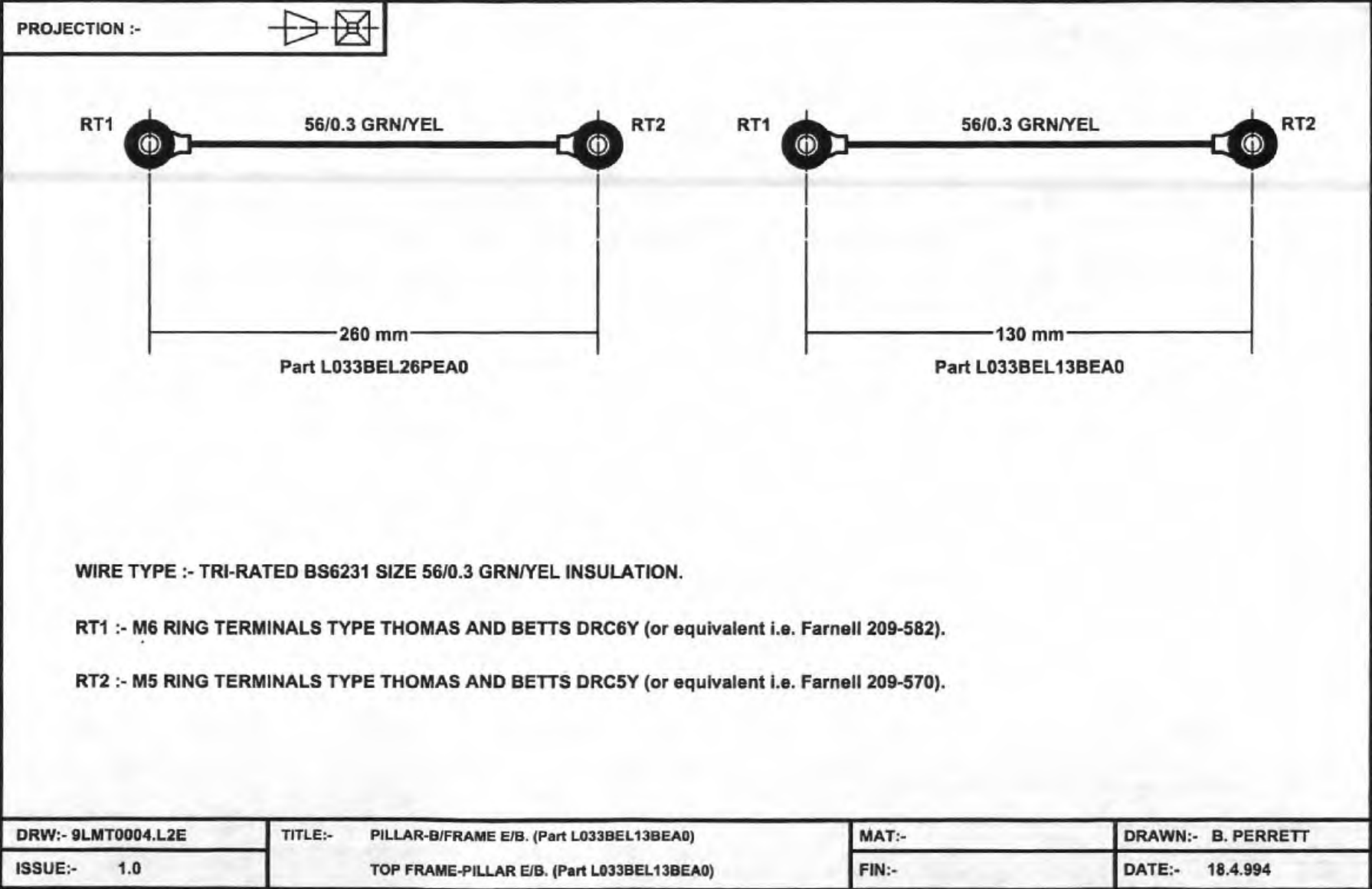

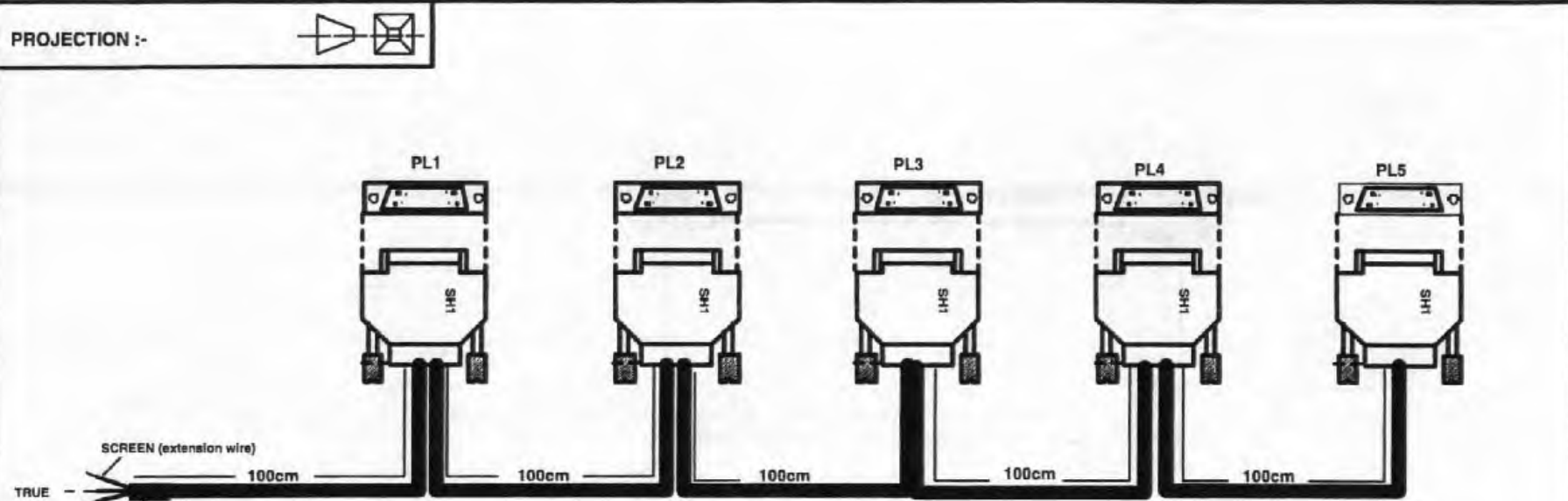

PL1 through PL5 :- Solder Bucket Plug 9-way (Farnell 105-505).

SH1:- Shroud type:- OSSI DPPK09BLACK (Farnell 148-640 or equivalent).

CABLE 1 :- 2-Core twisted pair with overall screen.(Farnell 148-545 (or equivalent). Sleeve is Hellermann H30Black.

- Note 1:- At each D-plug connect pins 1/2 to free end TRUE wire. (Daisy-chain PL1 to PL5).
- Note 2:- At each D-plug connect pins 4/5 to free end COMP wire. (Daisy-chain PL1 to PL5).
- Note 3:- At each D-plug connect pins 6/7/8/9 to free end of screen extension. (Daisy-chain PL1 to PL5).(Each pin 3 not used).
- Note 5:- At free end insulated pair and screen extension wire to extend 3cm beyond overall sheath with further 1cm on all wires stripped/twisted (not tinned)

Drawing Update :- Change of Shell type, Free wires not now tinned.

DRW:- 9LMT0004.SIO	TITLE :-	MAT :-	DRAWN :- B.PERRETT.
ISSUE :- 1.1	SCU TO CHANNEL SIO LOOM.(Part L033BSCUCIOA0)	FIN :-	DATE :- 18.4.94.



PROJECTION :-

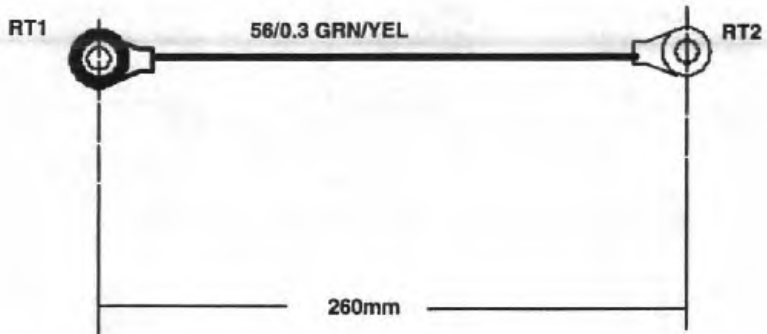
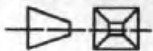

WIRE TYPE :- TRI-RATED BS6231 SIZE56/0.3 GRN/YEL INSULATION.

RT1/RT2 :- M6 RING TERMINALS TYPE THOMAS AND BETTS DRC6Y (or equivalent i.e. Farnell 209-582).

DRW:- 9LMT0004.L1E	TITLE :- TOP PANEL-TOP FRAME E/B. (Part L033BEL26TEA0)	MAT :-	DRAWN :- B.PERRETT.
ISSUE :- 1.0	S/PANEL-B/FRAME E/B. (Part L033BEL26BEA0)	FIN :-	DATE :- 18.4.94.



PROJECTION :-

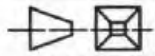

Modifications.

1.0 :- 6.2.95.
DCF L088. (BRP)

A1 :- 5/MAY/95
Blue crimp was yellow.
DRW was BLMT0006 L04
DRW N' now Part N'
Old Note 1 deleted.
DCF L161. (BRP)

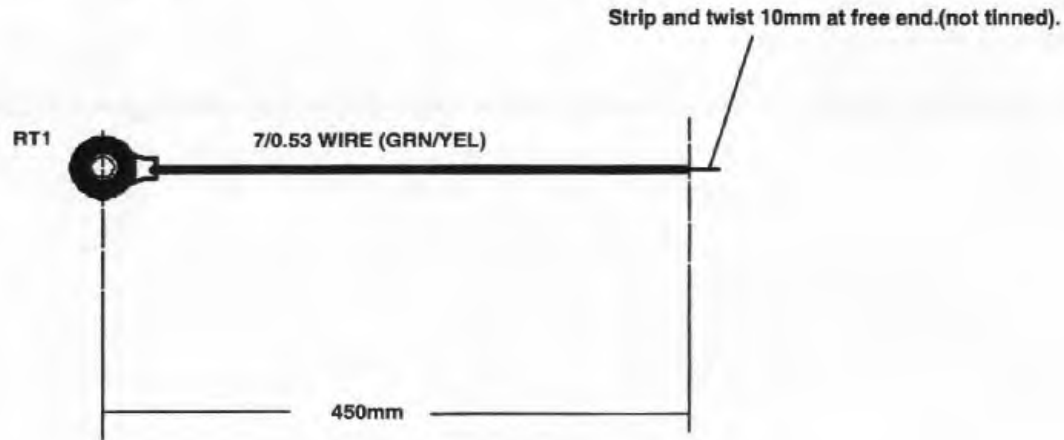

RT1 :- M5 RING TERMINALS TYPE THOMAS AND BETTS DRB5Y (or equivalent i.e. Farnell 209-533).

WIRE TYPE :- TRI-RATED 6491B-LSF SIZE 7/0.53 GREEN/YELLOW INSULATION.

NOTE 1 :- WIRE FREE END (NOT TINNED) IS CRIMPED TO A SECOND RING TERMINAL DURING FINAL INSTALLATION.
(CABLE CRIMPED AT BOTH ENDS WILL NOT PASS THROUGH SMALL RACK APERTURE).

DRW:- L033BSDISTE.	TITLE :- DISTRIBUTION BLK EARTH.	MAT :-	DRAWN :- B.PERRETT.
ISSUE :- A1		TOL :- ±10mm	DATE :- 6.2.95.



14. System Control Interface

Contents

General Assemblies	14-3
Module Parts List	14-5
Looms	14-6
SCI Front Panel Earth	L033SCIFPEXA0..... 14-6
SCI Front to Main Loom	L033SCIFTMLA0..... 14-7
SCI Mains	L033SCIMAINA0..... 14-8
SCI Power	L033SCIPWRXA0..... 14-9
SCI PSU Earth	L033SCIPSUEA0..... 14-10
SCI Wire	L033SCIWIREA0..... 14-11
PCB Parts List	14-12
Main	14-12
Front	14-15
Rear.....	14-16
RAM Bank	14-17
Overlays	14-18
Main	14-18
Front	14-19
Rear.....	14-20
RAM Bank	14-21
Circuit Diagrams	14-23
Main.....	14-23
Front	14-25
Rear.....	14-27
RAM Bank	14-29



Module Parts List

System Control Interface

Document No: LM030200007

Issue 1.1

Quantity	Description	Stock Number
1	3U SUB RACK	L0043USRACKA0
1	SCI FRONT PANEL	L004SCIFRPXA0
2	TAPPED STRIP 84HP	L004TST84HPA0
2	110V AC LABEL	L026110VLABA0
2	240V AC LABEL	L026240VLABA0
1	SERIAL N/D LABEL	L026SNLABELB0
2	102mm CABLE TIE	L029102TIESA0
23	M2.5 CRINKLE WASHER	L02925CWASHA0
28	M2.5X6 P/HEAD TORX BZCP	L02925P6MMTA0
2	M3X10 CSK TORX BZCP	L0293C10MMTA0
1	M4X12 PAN HEAD TORX BZCP	L0294P12MMTA0
12	M2.5 NUT BZCP	L029M25NUTXA0
8	M3 CLEARANCE SPACER 3mm	L029M3CS3MMA0
4	M3 CLEARANCE SPACER 5mm	L029M3CS5MMA0
9	M3 CRINKLE WASHER	L029M3CWASHA0
4	M3 M/F 8mm STUD SPACER	L029M3MF8SSA0
6	M3 NUT BZCP	L029M3NUTXXA0
4	M3X6 PAN HEAD TORX BZCP	L029M3P6MMTA0
2	M3 SHAKEPROOF WASHER	L029M3WASHSA0
1	M4 NUT BZCP	L029M4NUTXXA0
2	M4 SHAKEPROOF WASHER	L029M4WASHSA0
2	REPLACEMENT SCREW LOCKS	LC29RSCREWLA0
1	SCI FRONT PANEL EARTH	L033SCIFPEXA0
1	SCI MAINS	L033SCIMAINA0
1	SCI PSU EARTH	L033SCIPSUEA0
1	SCI POWER	L033SCIPWRXA0
1	SCI WIRE	L033SCIWIREA0
2	CABLE TIE CLAMP	L035CATIECLA0
1	HINGES (PAIR)	L035HINGESXA0
1	HORIZ MOUNTING KIT 160mm	L035HMK160XA0
1	MAINS FILTER 2A	L035MANFIL2A0
1	PSU 5V 1A 110/240V	L035PSU5V1AA0
16	RACK GUIDES	L035RGUIDESA0
1	SECURITY KEY SWITCH	L051SECKEYSA0
2	FUSE 1A 20mm A/S	L0721AX20ASA0
2	FUSE 500mA 20mm A/S	L07250020ASA0



SYSTEM CONTROL INTERFACE

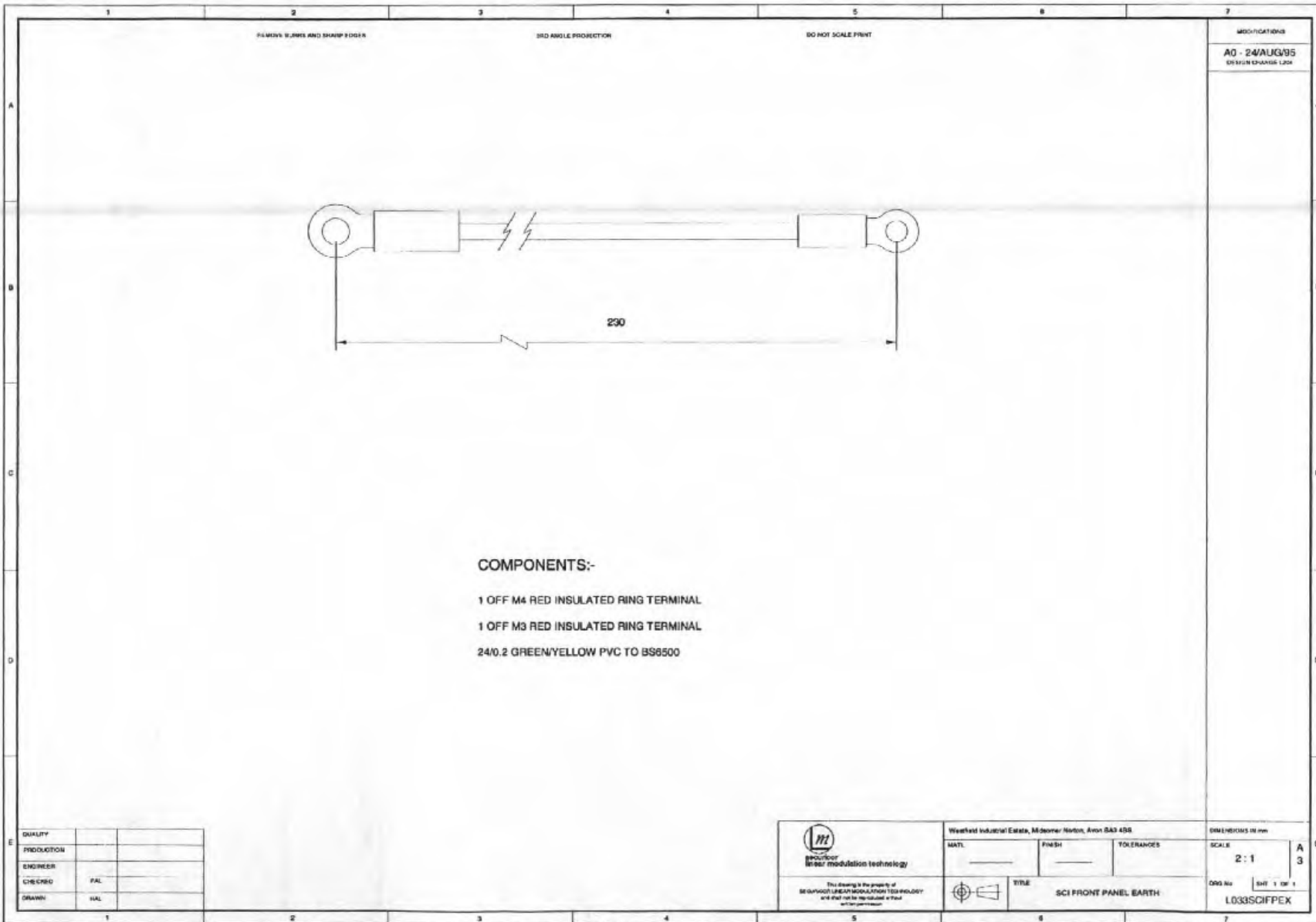

SYSTEM CONTROL INTERFACE

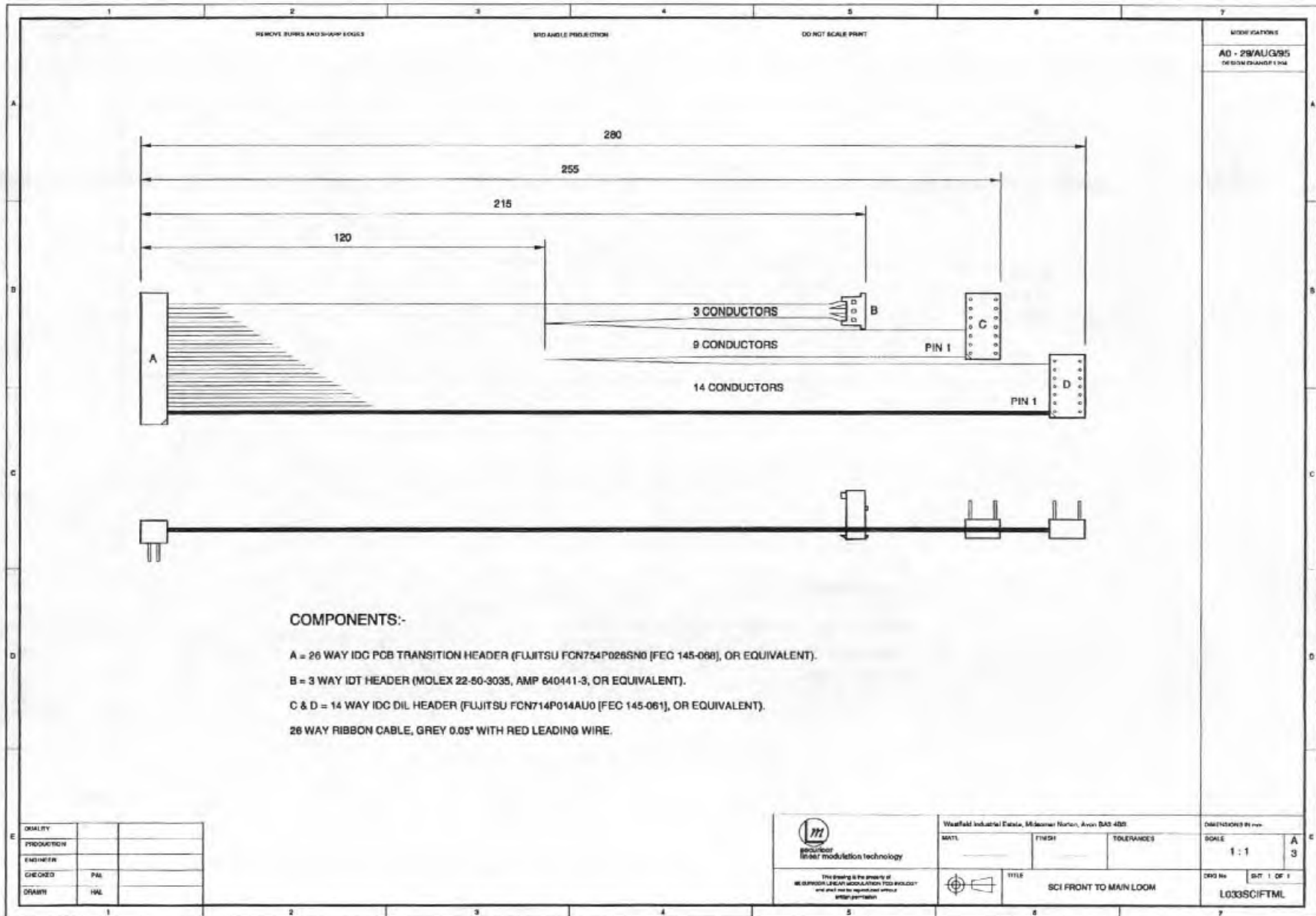

COMPONENTS:-

- A = 26 WAY IDC PCB TRANSITION HEADER (FUJITSU FCN754P028SN0 [FEG 145-068], OR EQUIVALENT).
- B = 3 WAY IDT HEADER (MOLEX 22-50-3035, AMP 640441-3, OR EQUIVALENT).
- C & D = 14 WAY IDC DIL HEADER (FUJITSU FCN714P014AU0 [FEG 145-061], OR EQUIVALENT).
- 26 WAY RIBBON CABLE, GREY 0.05" WITH RED LEADING WIRE.

DESIGN		
PRODUCTION		
ENGINEER		
CHECKED	PAI	
DRAWN	HVL	

 Molex linear modulation technology	Waukegan Industrial Estate, Macclesfield Station, Avon BAS 405			DIMENSIONS IN mm	
	MATL	FINISH	TOLERANCES	SCALE	A
This drawing is the property of Molex and shall not be reproduced without written permission			TITLE SCI FRONT TO MAIN LOOM		SHEET 1 OF 1 L033SCIFTML



SYSTEM CONTROL INTERFACE

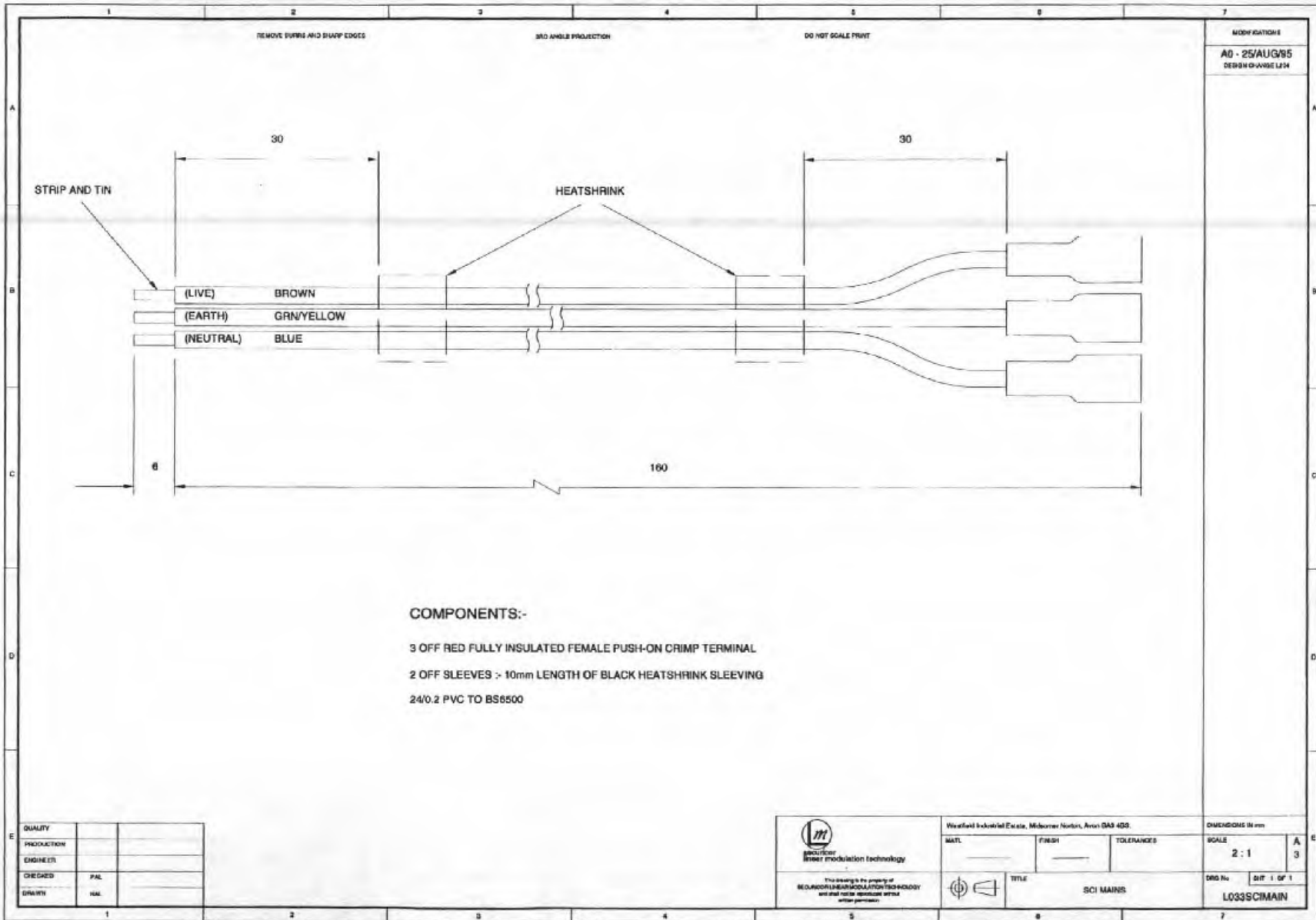

SYSTEM CONTROL INTERFACE

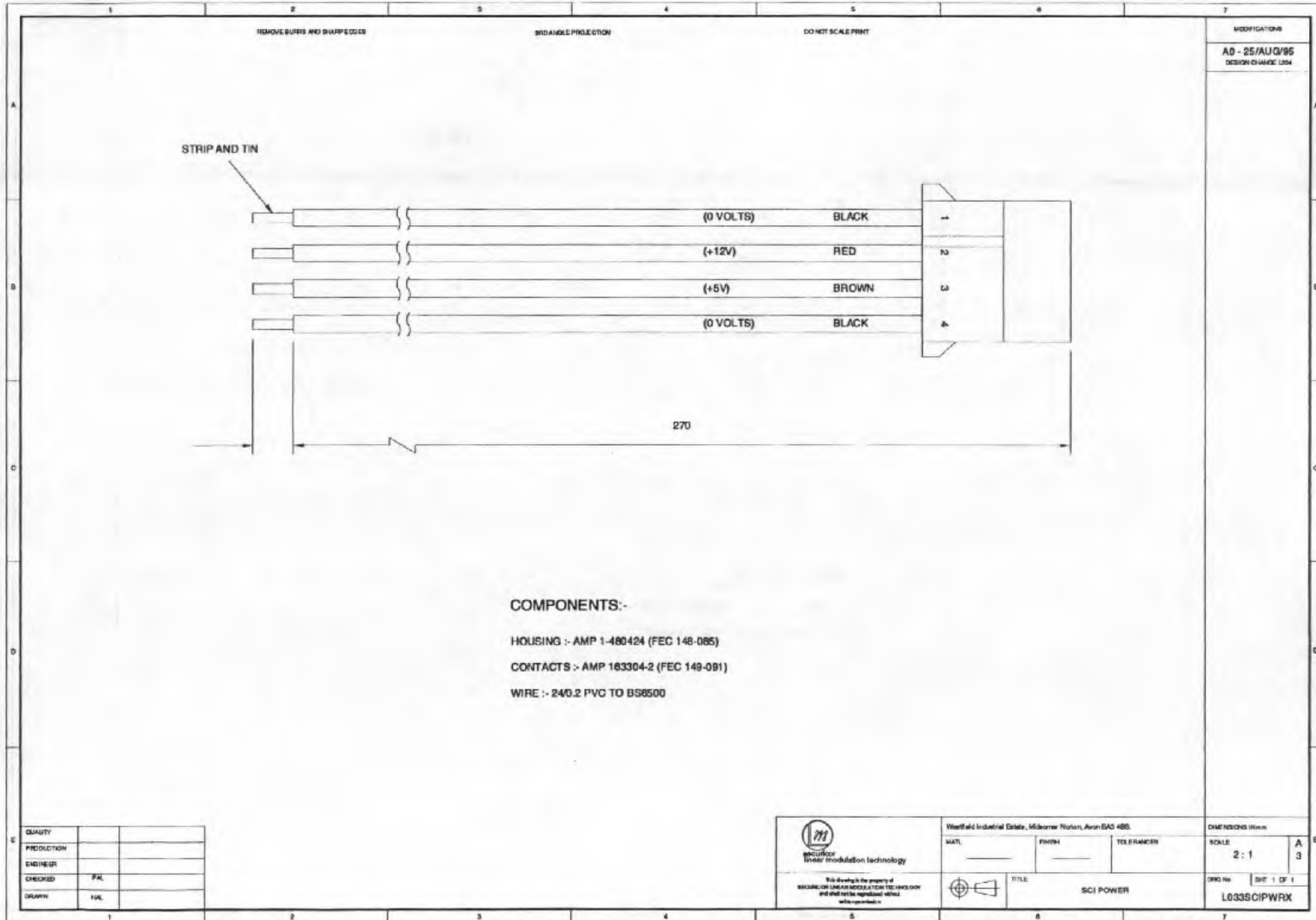

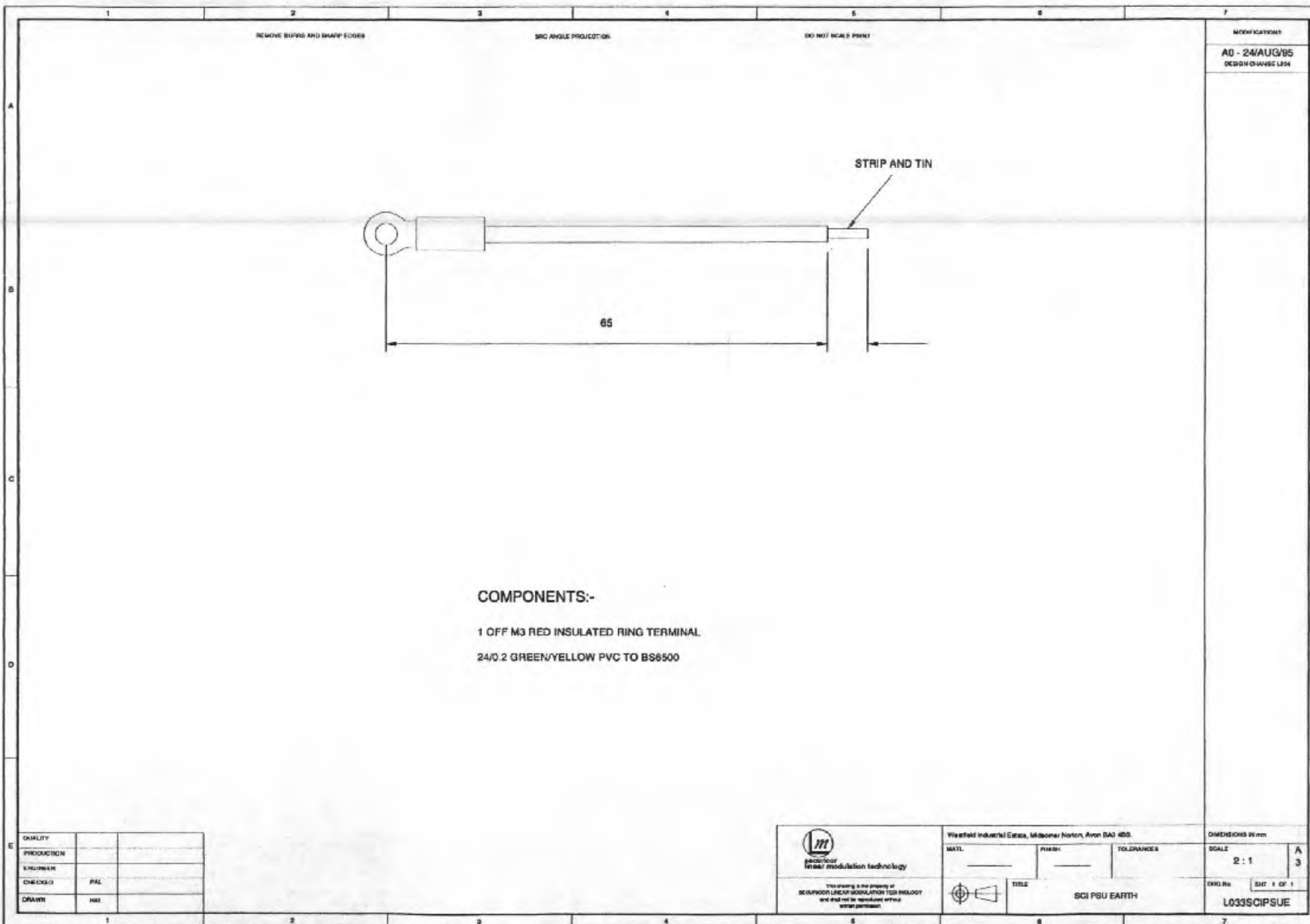

SYSTEM CONTROL INTERFACE

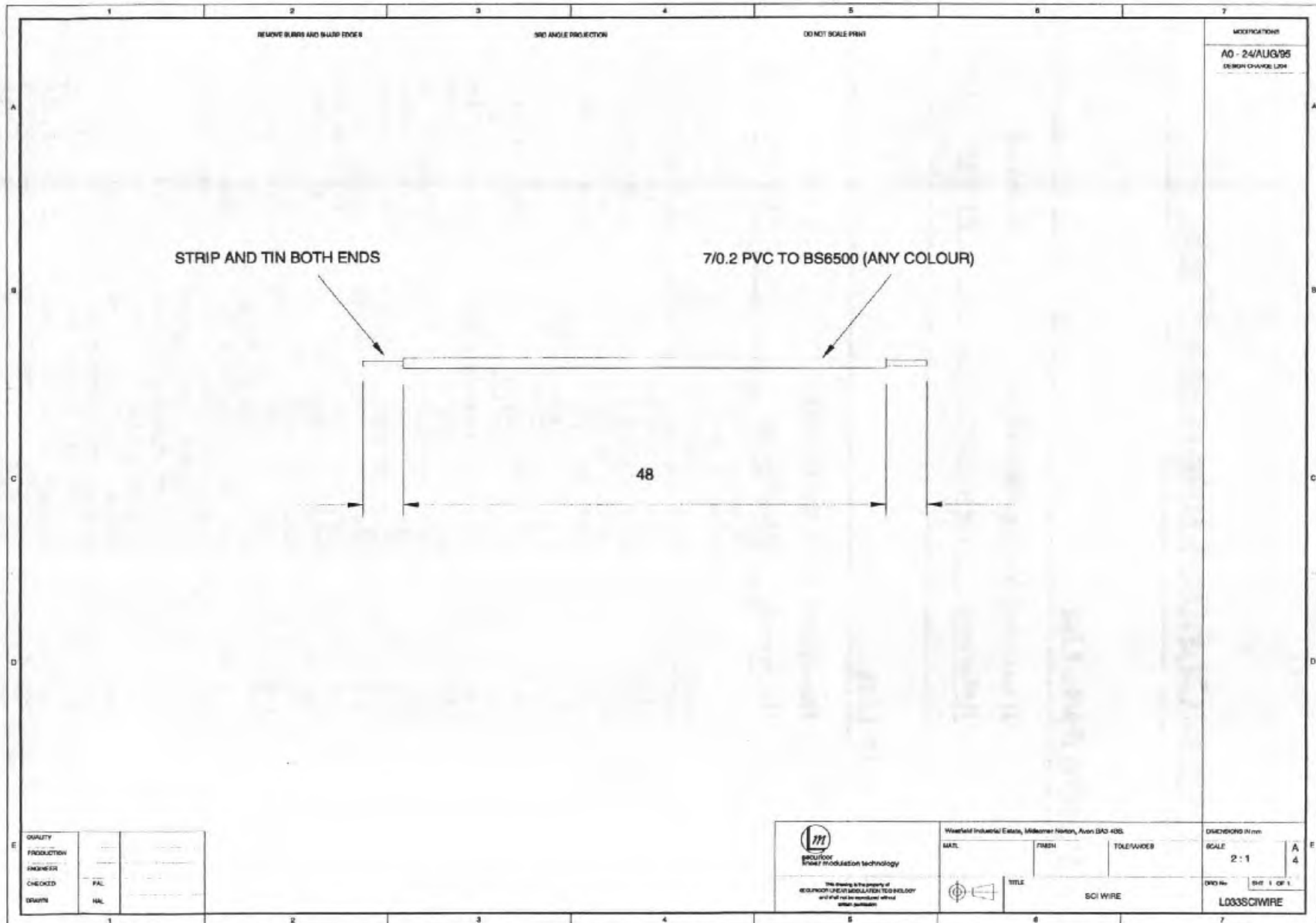



System Control Interface Main

Software Parts List

Document No: LM030500014

Issue 1.0

Reference	Description	Stock Number
IC17	S/WARE SCI MAIN	L058SCIMAINA0

PCB Parts List

Document No: LM030400042

Issue 1.0

Reference	Description	Stock Number
A	64 WAY PCB PLUG R\A	L01364WPPRAA0
B	64 WAY PCB PLUG R\A	L01364WPPRAA0
BATT	3.6V NI-CAD PCB BATTERY	L0173V6BATTA0
BATT1	3.6V NI-CAD PCB BATTERY	L0173V6BATTA0
C1	22pF CERAMIC M/L	L0669220ANXA0
C2	22pF CERAMIC M/L	L0669220ANXA0
C3	4n7 POLYESTER	L066472POLYA0
C4	22uF 16V TANT	L066226TANTA0
C5	100pF 100V MULTILAYER	L0669101ANXA0
C6	22pF CERAMIC M/L	L0669220ANXA0
C7	0.1uF POLYESTER	L066104POLYA0
C8	1uF 35V TANT 5mm	L066105T5MMA0
C9	0.01uF POLYESTER 7.5mm	L066103PY75A0
C10	22uF 16V TANT	L066226TANTA0
C11	22uF 16V TANT	L066226TANTA0
C12	22uF 16V TANT	L066226TANTA0
C13	22uF 16V TANT	L066226TANTA0
C14	CAP ELECT 100uF 16V 20%	L066PL1C101A0
C15	22uF 16V TANT	L066226TANTA0
C16	22uF 16V TANT	L066226TANTA0
C17	22uF 16V TANT	L066226TANTA0
C18	22uF 16V TANT	L066226TANTA0
C19	0.01uF POLYESTER 7.5mm	L066103PY75A0
C20	0.01uF POLYESTER 7.5mm	L066103PY75A0
C21	0.01uF POLYESTER 7.5mm	L066103PY75A0
C22	0.01uF POLYESTER 7.5mm	L066103PY75A0
C23	0.01uF POLYESTER 7.5mm	L066103PY75A0
C24	0.01uF POLYESTER 7.5mm	L066103PY75A0
C25	0.01uF POLYESTER 7.5mm	L066103PY75A0
C26	0.01uF POLYESTER 7.5mm	L066103PY75A0
C27	0.01uF POLYESTER 7.5mm	L066103PY75A0
C28	0.01uF POLYESTER 7.5mm	L066103PY75A0
C29	0.01uF POLYESTER 7.5mm	L066103PY75A0
C30	0.01uF POLYESTER 7.5mm	L066103PY75A0
C31	0.01uF POLYESTER 7.5mm	L066103PY75A0
C32	0.01uF POLYESTER 7.5mm	L066103PY75A0
C33	0.01uF POLYESTER 7.5mm	L066103PY75A0



C34	0.01uF POLYESTER 7.5mm	L066103PY75A0
C35	0.01uF POLYESTER 7.5mm	L066103PY75A0
C36	0.01uF POLYESTER 7.5mm	L066103PY75A0
C37	0.01uF POLYESTER 7.5mm	L066103PY75A0
C38	0.01uF POLYESTER 7.5mm	L066103PY75A0
C39	0.01uF POLYESTER 7.5mm	L066103PY75A0
C40	0.01uF POLYESTER 7.5mm	L066103PY75A0
C41	0.01uF POLYESTER 7.5mm	L066103PY75A0
C42	0.01uF POLYESTER 7.5mm	L066103PY75A0
C43	0.01uF POLYESTER 7.5mm	L066103PY75A0
C44	0.01uF POLYESTER 7.5mm	L066103PY75A0
C45	0.01uF POLYESTER 7.5mm	L066103PY75A0
CONN	64 WAY PCB PLUG R\A	L01364WPPRAA0
D1	DIODE 4V7 ZENER	L0634V7ZENXA0
D2	1N4148	L063C1N4148A0
D3	1N4148	L063C1N4148A0
D4	1N4148	L063C1N4148A0
D5	DIODE 6V8 ZENER	L0636V8ZENXA0
D6	DIODE BAT42	L063BAT42XXA0
D7	DIODE BAT42	L063BAT42XXA0
D8	DIODE BAT42	L063BAT42XXA0
D9	DIODE BAT42	L063BAT42XXA0
D10	DIODE BAT42	L063BAT42XXA0
D11	DIODE BAT42	L063BAT42XXA0
H1	AVTRONIC 2.5mm	L029AVT25MMA0
H2	AVTRONIC 2.5mm	L029AVT25MMA0
H3	AVTRONIC 2.5mm	L029AVT25MMA0
H4	AVTRONIC 2.5mm	L029AVT25MMA0
HDR1	14 WAY DIL HEADER SOCKET	L01314WDHSXA0
HDR1	14 WAY DIL HEADER COVER	L01314WDHCXA0
HDR2	14WAY IC SOCKET	L013DIL14XXA0
HDR3	14WAY IC SOCKET	L013DIL14XXA0
IC1	IC HD6303RP (DIL40)	L057HD6303XA0
IC2	IC 4521 (DIL16)	L0574521XXXA0
IC3	IC 74HCT244 (DIL20)	L057HCT244XA0
IC4	IC 74HCT244 (DIL20)	L057HCT244XA0
IC5	IC 74HCT245 (DIL20)	L057HCT245XA0
IC6	IC 74HCT245 (DIL20)	L057HCT245XA0
IC7	IC DS8820N (DIL14)	L057DS8820NA0
IC8	IC DS8831N (DIL16)	L057DS8831NA0
IC9	IC 74HCT02 (DIL14)	L057HCT02XXA0
IC10	IC 4060 (DIL16)	L0574060XXXXA0
IC11	IC 74HCT04 (DIL14)	L057HCT04XXA0
IC12	MAX232 [DIL-16]	L057MAX232LA0
IC13	IC HD6350P (DIL 24)	L057HD6350XA0
IC14	IC HD6350P (DIL 24)	L057HD6350XA0
IC15	MAX232 [DIL-16]	L057MAX232LA0
IC16	IC HM6264ALP	L0576264XXXXA0
IC17	28WAY IC SOCKET	L013DIL28XXA0
IC18	IC HM62256ALP-10 (DIL28)	L05762256XXA0
IC18	28WAY IC SOCKET	L013DIL28XXA0
IC19	28WAY IC SOCKET	L013DIL28XXA0
IC19	IC HM62256ALP-10 (DIL28)	L05762256XXA0
IC20	IC MM58174AN (DIL16)	L05758174XXA0
IC21	IC HD6321P (DIL40)	L057HD6321PA0
IC22	IC 74C923 (DIL20)	L05774C923XA0
IC23	IC HD6321P (DIL40)	L057HD6321PA0
IC24	IC HD6321P (DIL40)	L057HD6321PA0
IC25	IC 74HCT32 (DIL14)	L057HCT32XXA0
IC26	IC 4011 (DIL14)	L0574011XXXXA0
IC27	IC 74F138 (DIL16)	L05774F138XA0
IC28	IC 74F138 (DIL16)	L05774F138XA0
INS1	HC49 CRYSTAL INSULATOR	L035HC49INSA0



INS2	HC49 CRYSTAL INSULATOR	L035HC49INSA0
L6	20 SWG TIN COPPER WIRE	L032TCW20WGA0
PCB1	SCI X91 MAIN PCB	L001SCIX91XA0
PL1	3 X 1 TERMINAL STRIP	L01303X1TSXA0
PL2	6 X 1 TERMINAL STRIP	L01306X1TSXA0
R1	10K LEADED 0.25W 5%	L06991035C4A0
R2	10K LEADED 0.25W 5%	L06991035C4A0
R3	100K LEADED 0.25W 5%	L06991045C4A0
R4	100K LEADED 0.25W 5%	L06991045C4A0
R5	10K LEADED 0.25W 5%	L06991035C4A0
R6	10K LEADED 0.25W 5%	L06991035C4A0
R7	270R LEADED 0.25W 5%	L06992715C4A0
R8	470R LEADED 0.25W 5%	L06994715C4A0
R9	1K LEADED 0.25W 5%	L06991025C4A0
R10	10K LEADED 0.25W 5%	L06991035C4A0
R11	10K LEADED 0.25W 5%	L06991035C4A0
R12	1M LEADED 0.25W 1%	L06991051M4A0
R13	10K LEADED 0.25W 5%	L06991035C4A0
R14	10K LEADED 0.25W 5%	L06991035C4A0
R15	10K LEADED 0.25W 5%	L06991035C4A0
R16	1K LEADED 0.25W 5%	L06991025C4A0
R17	1K LEADED 0.25W 5%	L06991025C4A0
R18	220R LEADED 0.25W 5%	L06992211M4A0
TR1	TRANSISTOR ZTX300	L060ZTX300XA0
TR2	TRANSISTOR ZTX300	L060ZTX300XA0
VC1	5.5-65pF VARIABLE CAP	L066565PFXXA0
VR1	20K PRESET POT	L06920KPOTXA0
XL1	CRYSTAL 4.032 MHz	L0554M032XXA0
XL2	CRYSTAL 4.9152MHz	L0554M9152XA0
XL3	XTAL 32.768KHz (WATCH A)	L05532768XXA0



System Control Interface Front

PCB Parts List

Document No: LM030400044

Issue 1.0

Reference	Description	Stock Number
-----------	-------------	--------------

CON1	SCI WIRE	L033SCIWIREA0
CON2	15 WAY CABLE JUMPER LINK	L03215WCJLXA0
CON3	SCI FRONT TO MAIN LOOM	L033SCIFTMLA0
LCD1	LCD 16 x 2	L054LCD16X2A0
LED1	5mm GREEN LED LC	L0545GLEDLCA0
PCB1	SCI X120 FRONT PCB	L001SCIX120A0
SW1	KEYBOARD SWITCH	L051KEYBRDSA0
SW2	KEYBOARD SWITCH	L051KEYBRDSA0
SW3	KEYBOARD SWITCH	L051KEYBRDSA0
SW4	KEYBOARD SWITCH	L051KEYBRDSA0
SW5	KEYBOARD SWITCH	L051KEYBRDSA0
SW6	KEYBOARD SWITCH	L051KEYBRDSA0
SW7	KEYBOARD SWITCH	L051KEYBRDSA0
SW8	KEYBOARD SWITCH	L051KEYBRDSA0
SW9	KEYBOARD SWITCH	L051KEYBRDSA0
SW10	KEYBOARD SWITCH	L051KEYBRDSA0
SW11	KEYBOARD SWITCH	L051KEYBRDSA0
SW12	KEYBOARD SWITCH	L051KEYBRDSA0
SW13	KEYBOARD SWITCH	L051KEYBRDSA0
SW14	KEYBOARD SWITCH	L051KEYBRDSA0
SW15	KEYBOARD SWITCH	L051KEYBRDSA0
SW16	KEYBOARD SWITCH	L051KEYBRDSA0
SW17	KEYBOARD SWITCH	L051KEYBRDSA0
SW18	KEYBOARD SWITCH	L051KEYBRDSA0
SW19	KEYBOARD SWITCH	L051KEYBRDSA0
SW20	KEYBOARD SWITCH	L051KEYBRDSA0



System Control Interface Rear

PCB Parts List

Document No: LM030400045 -

Issue 1.0

Reference	Description	Stock Number
A	64 WAY PCB SOCKET	L01364WPSXXA0
A	D-TYPE 25W SOCKET	L013DT25WSKA0
B	D-TYPE 25W SOCKET	L013DT25WSKA0
B	64 WAY PCB SOCKET	L01364WPSXXA0
P	4WAY PCB POWER CONNECTOR	L0134WPCBPACA0
BUS	3 WAY PCB TERMINAL BLOCK	L0133WTERMBA0
C1	0.1uF POLYESTER	L066104POLYAC
C2	0.1uF POLYESTER	L066104POLYAC
D1	DIODE 1N5404	L0631N5404XA0
dcI	4WAY PCB POWER CONNECTOR	L0134WPCBPACA0
FUSE	FUSE HOLDER 20 x 5mm	L072M20FHXXA0
FUSE	FUSE 1A 20mm A/S	L0721AX20ASA0
H1	AVTRONIC 2.8mm	L029AVT28MMA0
H2	AVTRONIC 2.8mm	L029AVT28MMA0
H3	AVTRONIC 2.8mm	L029AVT28MMA0
H4	AVTRONIC 2.8mm	L029AVT28MMA0
H5	AVTRONIC 2.8mm	L029AVT28MMA0
H6	AVTRONIC 2.8mm	L029AVT28MMA0
H7	AVTRONIC 2.8mm	L029AVT28MMA0
H8	AVTRONIC 2.8mm	L029AVT28MMA0
H9	AVTRONIC 2.8mm	L029AVT28MMA0
H10	AVTRONIC 2.8mm	L029AVT28MMA0
H11	AVTRONIC 2.8mm	L029AVT28MMA0
H12	AVTRONIC 2.8mm	L029AVT28MMA0
H13	AVTRONIC 2.8mm	L029AVT28MMA0
H14	AVTRONIC 2.8mm	L029AVT28MMA0
H15	AVTRONIC 2.8mm	L029AVT28MMA0
H16	AVTRONIC 2.8mm	L029AVT28MMA0
H17	14.5 mm SCREWLOCK	L02914MMSLKA0
H18	14.5 mm SCREWLOCK	L02914MMSLKA0
H19	6mm CLEARANCE SPACER	L0356MSPACEA0
H20	6mm CLEARANCE SPACER	L0356MSPACEA0
H21	6mm CLEARANCE SPACER	L0356MSPACEA0
H22	6mm CLEARANCE SPACER	L0356MSPACEA0
LT	FUSE HOLDER 20 x 5mm	L072M20FHXXA0
LT	FUSE 1A 20mm A/S	L0721AX20ASA0
PCB1	SCI X91BP REAR PCB —	L001SCI91BA0
PORT	D-TYPE 25W SOCKET	L013DT25WSKA0
PSU	4WAY PCB POWER CONNECTOR	L0134WPCBPACA0
PSU12V	4WAY PCB POWER CONNECTOR	L0134WPCBPACA0
RBC1	64 WAY PCB SOCKET	L01364WPSXXA0
RBC2	64 WAY PCB SOCKET	L01364WPSXXA0
RBC3	64 WAY PCB SOCKET	L01364WPSXXA0
RBC4	64 WAY PCB SOCKET	L01364WPSXXA0
RBC5	64 WAY PCB SOCKET	L01364WPSXXA0
RBC6	64 WAY PCB SOCKET	L01364WPSXXA0
SIO	3 WAY PCB TERMINAL BLOCK	L0133WTERMBA0
ZD1	DIODE 6V8 ZENER 5W	L0636V8ZEN5A0



System Control Interface RAM Bank

PCB Parts List

Document No: LM030400043

Issue 1.0

Reference	Description	Stock Number
BAT1	3.6V NI-CAD PCB BATTERY	L0173V6BATTAA0
C1	0.1uF CERAMIC CAP	L066104CERXA0
C2	0.1uF CERAMIC CAP	L066104CERXA0
C3	0.1uF CERAMIC CAP	L066104CERXA0
CON1	64 WAY PCB PLUG R\A	L01354WPPRAA0
D1	DIODE BAT42	L063BAT42XXA0
D2	DIODE BAT42	L063BAT42XXA0
D3	DIODE BAT42	L063BAT42XXA0
DC1	0.01uF POLYESTER	L066103POLYA0
DC2	0.01uF POLYESTER	L066103POLYA0
DC3	0.01uF POLYESTER	L066103POLYA0
DC4	0.01uF POLYESTER	L066103POLYA0
DC5	0.01uF POLYESTER	L066103POLYA0
DC6	0.01uF POLYESTER	L066103POLYA0
DC7	0.01uF POLYESTER	L066103POLYA0
DC8	0.01uF POLYESTER	L066103POLYA0
H1	AVTRONIC 2.5mm	L029AVT25MMA0
H2	AVTRONIC 2.5mm	L029AVT25MMA0
IC1	IC DS1211 [DIL-20]	L057DS1211XA0
IC2	IC 74HC138 [DIL-16]	L05774HC138A0
IC3	IC HM62256ALP-10 (DIL28)	L05762256XXA0
IC4	IC HM62256ALP-10 (DIL28)	L05762256XXA0
IC5	IC HM62256ALP-10 (DIL28)	L05762256XXA0
IC6	IC HM62256ALP-10 (DIL28)	L05762256XXA0
IC7	IC 74HC244 [DIL-20]	L05774HC244A0
IC8	IC 74HC00 [DIL-14]	L05774HC00XA0
LED1	PCB MOUNT RED LED	L054PCBRLEDA0
LED2	PCB MOUNT GREEN LED	L054PCBGLEDA0
LED3	PCB MOUNT YELLOW LED	L054PCBYLEDA0
PCB1	SCI X90-1 RAMBANK PCB	L001SCIX901A0
R1	2K2 LEADED 0.25W 5%	L06992225M4A0
R2	1M LEADED 0.25W 1%	L06991051M4A0
R3	3M3 LEADED 0.25W 5%	L06993355C4A0
R4	1M LEADED 0.25W 1%	L06991051M4A0
R5	1M LEADED 0.25W 1%	L06991051M4A0
SW1	8 WAY DIL SWITCH	L0518WAYDILA0
SW2	PCB MOUNT SWITCH	L051PCBSWXXA0



System Control Interface Main

X91 SYSTEM CONTROL INTERFACE VERSION II
ISSUE B

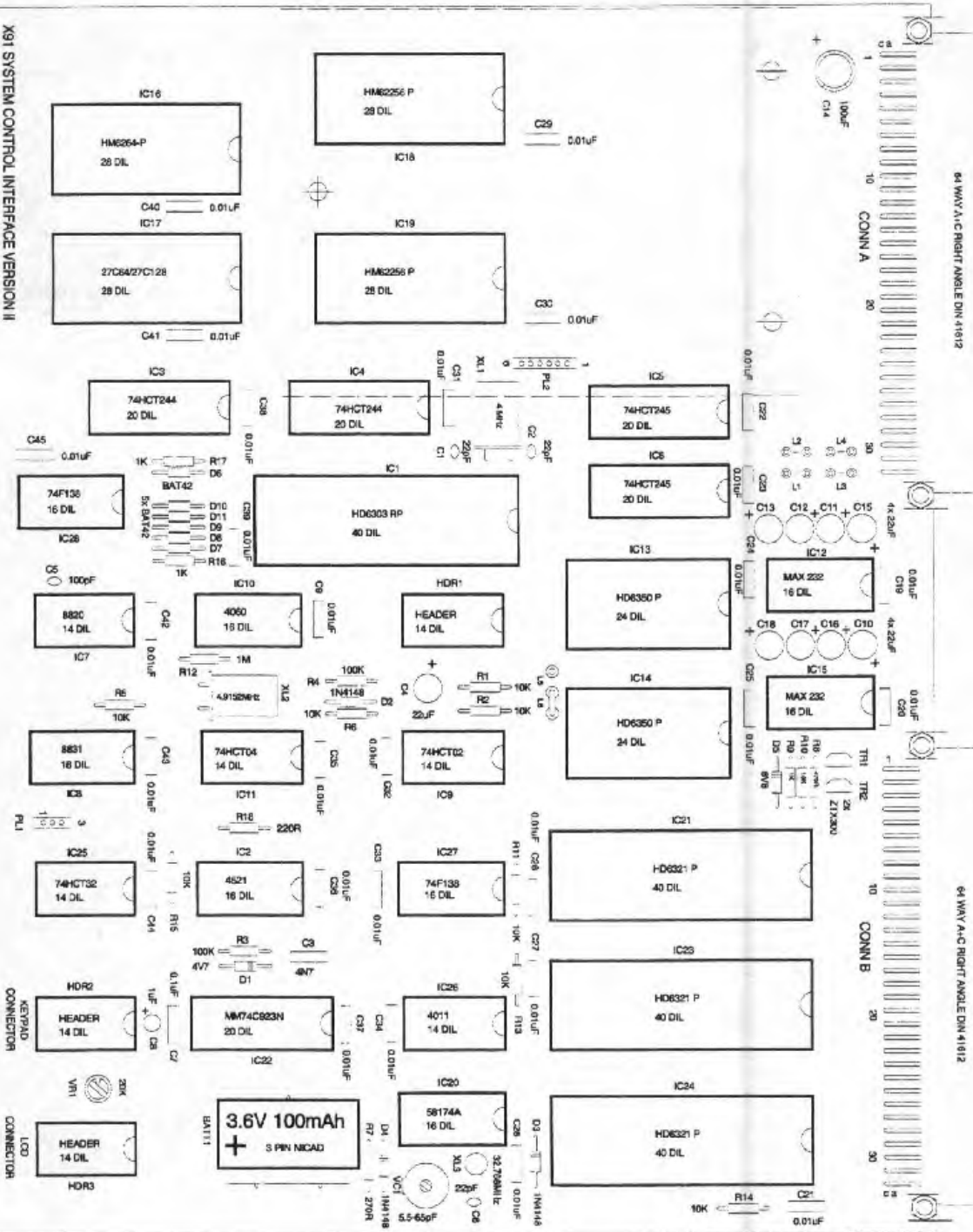



System Control Interface Front

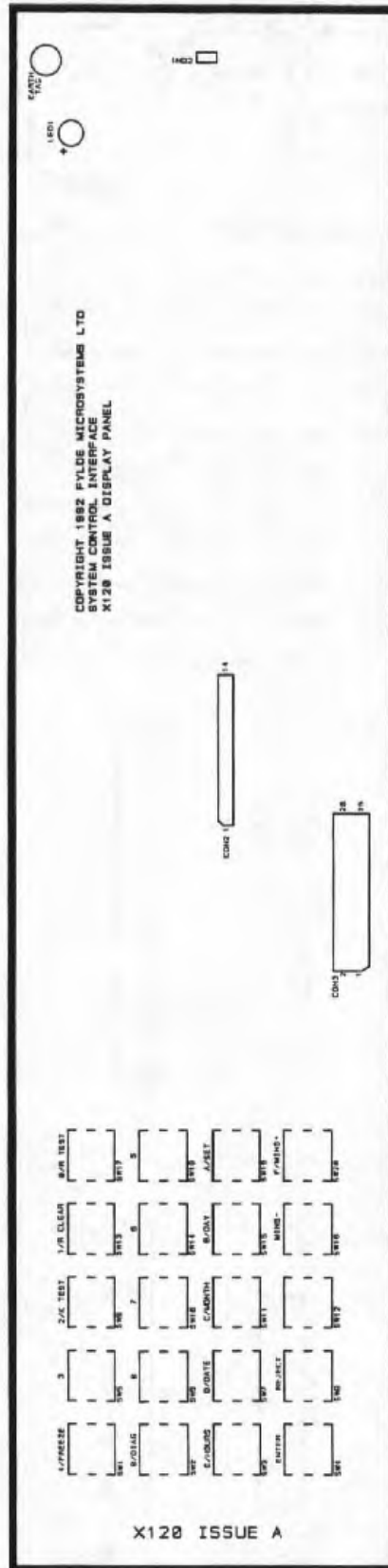



System Control Interface Rear

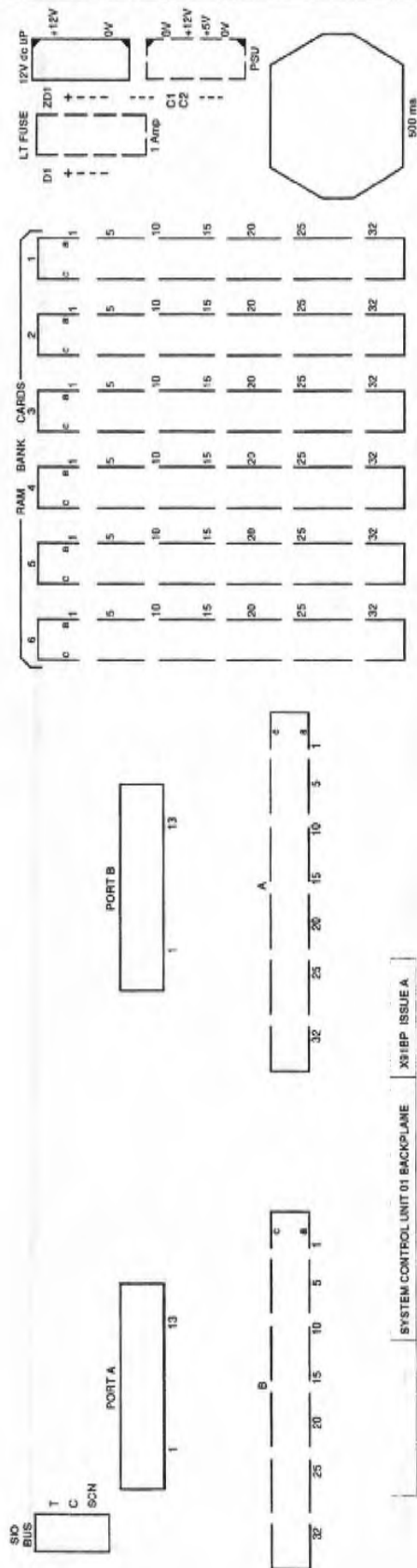



System Control Interface RAM Bank

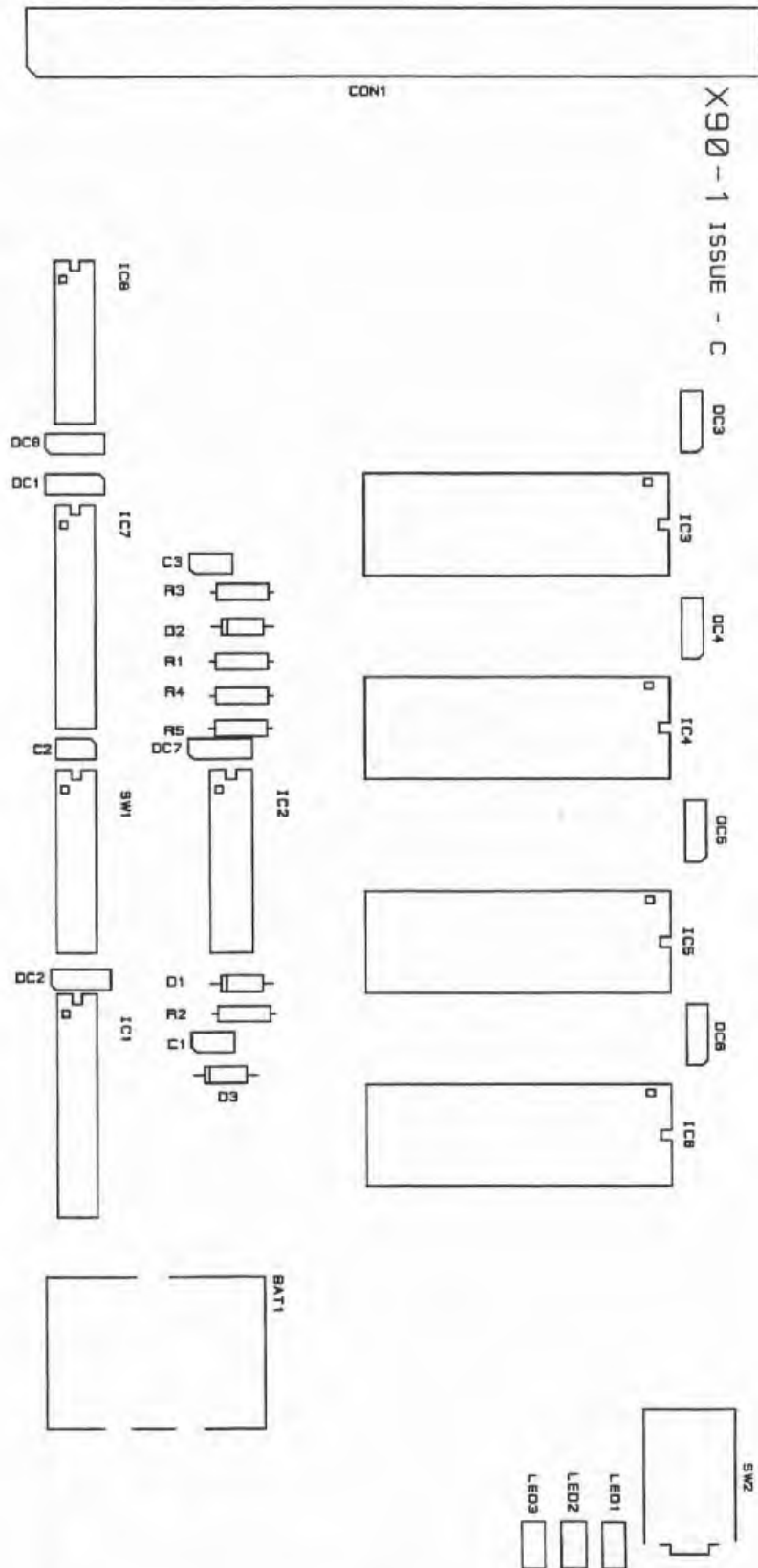



15. 10 MHz Frequency Standard

Contents

General Assemblies	15-3
Module Parts List	15-7
Looms	15-8
Red LED LoomL033FSL01IXA0.....	15-8
IEC/Select/Fuse LoomL033FSL02IXA1.....	15-9
Freq Int/Ext LoomL033FSL05IXA0.....	15-11
PCB Parts List	15-13
Overlays	15-17
Circuit Diagrams	15-19

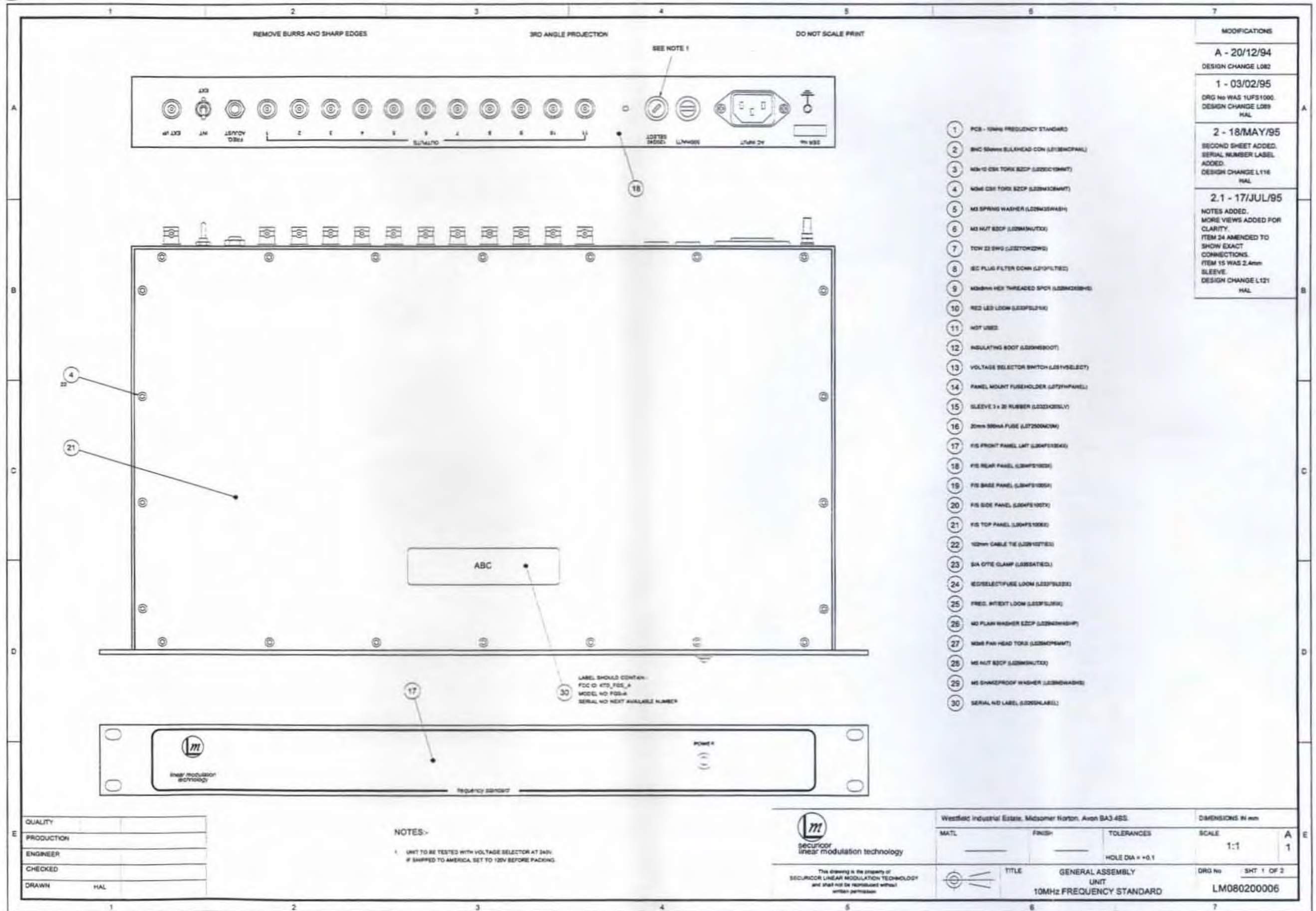

MODIFICATIONS	
A - 20/12/94	DESIGN CHANGE L082
1 - 03/02/95	DRG No WAS 1UFS1000. DESIGN CHANGE L089 HAL
2 - 18/MAY/95	SECOND SHEET ADDED. SERIAL NUMBER LABEL ADDED. DESIGN CHANGE L116 HAL
2.1 - 17/JUL/95	NOTES ADDED. MORE VIEWS ADDED FOR CLARITY. ITEM 24 AMENDED TO SHOW EXACT CONNECTIONS. ITEM 15 WAS 2.4mm SLEEVE. DESIGN CHANGE L121 HAL

- 1 PCB - 10MHZ FREQUENCY STANDARD
- 2 BNC BRAHNS BULKHEAD CON (L01380CFANL)
- 3 M3x10 CSK TORX SCREW (L020010MNT)
- 4 M3x6 CSK TORX SCREW (L020010MNT)
- 5 M3 SPRING WASHER (L020040WASH)
- 6 M3 NUT SCREW (L020010NUT)
- 7 TORX 22 SWG (L0210020W)
- 8 IEC PLUG FILTER COVER (L01010183)
- 9 M3x8mm HEX THREADED SCREW (L020008H)
- 10 RED LED LOOM (L02010110)
- 11 NOT USED
- 12 INSULATING BOOT (L020000BOOT)
- 13 VOLTAGE SELECTOR SWITCH (L01010103)
- 14 PANEL MOUNT FUSE HOLDER (L01010104)
- 15 SLEEVE 3 x 20 RUBBER (L020000SLV)
- 16 20mm BUNA FUSE (L0120000FM)
- 17 FIS FRONT PANEL LMT (L000101040)
- 18 FIS REAR PANEL (L000101000)
- 19 FIS BASE PANEL (L000101000)
- 20 FIS SIDE PANEL (L000101000)
- 21 FIS TOP PANEL (L000101000)
- 22 10mm CABLE TIE (L02100100)
- 23 BIA OTTE CLAMP (L00010100)
- 24 RED SELECTOR FUSE LOOM (L02010100)
- 25 FREQ. INTENT LOOM (L02010100)
- 26 M3 FLANK WASHER SCREW (L020000WASH)
- 27 M3x6 PAN HEAD TORX (L020000MNT)
- 28 M3 NUT SCREW (L020000NUT)
- 29 M3 SHOCKPROOF WASHER (L020000WASH)
- 30 SERIAL NO LABEL (L020000LABEL)

QUALITY	
PRODUCTION	
ENGINEER	
CHECKED	
DRAWN	HAL

NOTES:-
 1. UNIT TO BE TESTED WITH VOLTAGE SELECTOR AT 240V IF SHIPPED TO AMERICA SET TO 120V BEFORE PACKING.

 SECURECO linear modulation technology <small>This drawing is the property of SECURECO LINEAR MODULATION TECHNOLOGY and shall not be reproduced without written permission.</small>		Westfield Industrial Estate, Midsomer Norton, Avon BA3 4SS. DIMENSIONS IN mm		
MATL	FINISH	TOLERANCES	SCALE	A
		HOLE DIA = +0.1	1:1	1
TITLE GENERAL ASSEMBLY UNIT 10MHZ FREQUENCY STANDARD		DRG No SHT 1 OF 2 LM080200006		

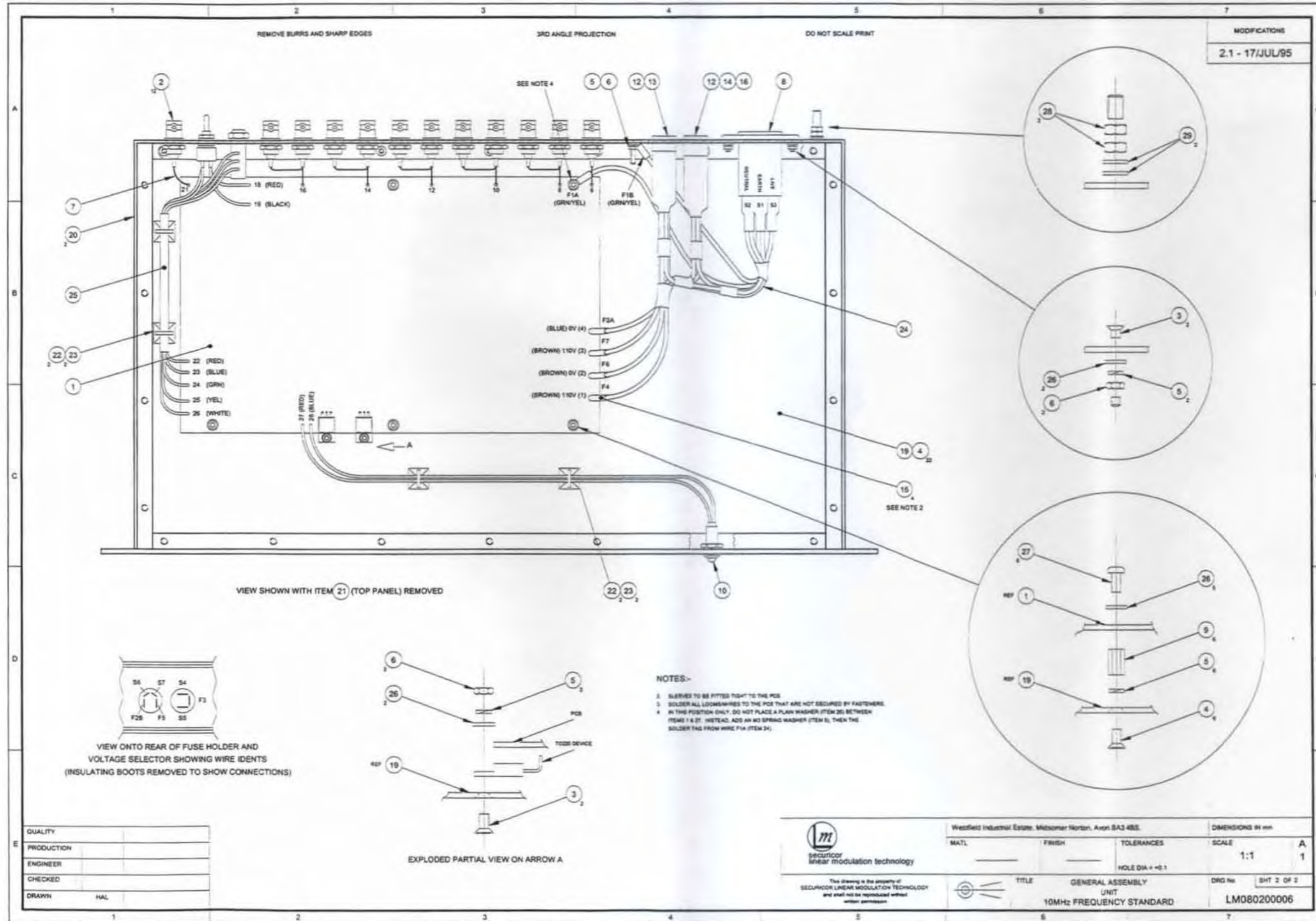



Module Parts List

10 MHz Frequency Standard

Document No: LM030200006

Issue 1.1

Quantity	Description	Stock Number
1	F/S REAR PANEL	L004FS1003XA1
1	F/S FRONT PANEL LMT	L004FS1004XB0
1	F/S BASE PANEL	L004FS1005XA0
1	F/S TOP PANEL	L004FS1006XA0
2	F/S SIDE PANEL	L004FS1007XA0
12	BNC 50 Ohms BULKHEAD CON	L013BNCPANLAC
1	IEC PLUG FILTER CONN	L013FILTIECA0
2	INSULATING BOOT	L020INSBOOTAD
1	SERIAL N/D LABEL	L026SNLABELB0
4	102mm CABLE TIE	L029102TIESA0
4	M3X10 CSK TORX BZCP	L0293C10MMTA0
50	M3X6 CSK TORX BZCP	L029M3C6MMTA0
5	M3 NUT BZCP	L029M3NUTXXA0
6	M3X6 PAN HEAD TORX BZCP	L029M3P6MMTA0
12	M3 SPRING WASHER	L029M3SWASHA0
9	M3 PLAIN WASHER BZCP	L029M3WASHPA0
6	M3x8mm HEX THREADED SPCR	L029M3X08HSA0
2	M5 NUT BZCP	L029M5NUTXXA0
2	M5 SHAKEPROOF WASHER	L029M5WASHSA0
4	SLEEVE 3 x 20 RUBBER	L0323X20SLVA0
0.3	TCW 22 SWG	L032TCW22WGA0
1	RED LED LOOM	L033FSL01IXA0
1	IEC/SELECT/FUSE LOOM	L033FSL02IXA1
1	FREQ INT/EXT LOOM	L033FSL05IXA0
4	S/A C/TIE CLAMP	L035SATIECLA0
1	VOLTAGE SELECTOR SWITCH	L051VSELECTA0
1	20mm 500mA FUSE	L072500M20MA0
1	PANEL MOUNT FUSEHOLDER	L072FHPANELA0



PROJECTION :-

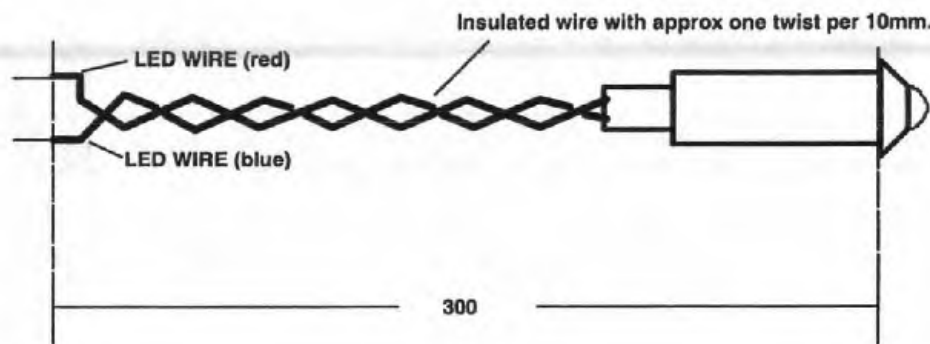
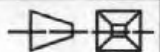

FREE WIRES TO BE STRIPPED AND TINNED 5mm (min).

RED PANEL MOUNTING LED :- TYPE HERO SMRD-080-12 .(To be supplied with Spring Washer and Locking Nut).
(This part is also recognized by HERO as SMRD-080-082)

Note 1 :- The required LED lead length may exceed manufacturers standard limit. Auxiliary extention wires suitably sleeved are acceptable.

Note 2 :- In final installation red lead connects to Frequency Standard pcb/pin27 and blue lead to pcb/pin 28.

DRW:- 8LMT0007.L3I

TITLE :-

MAT :-

DRAWN :- B.PERRETT.

ISSUE :- 1.0

RED LED LOOM. (Part L033FSL01IXA0)

TOL :- 5mm

DATE :- 27.10.94.

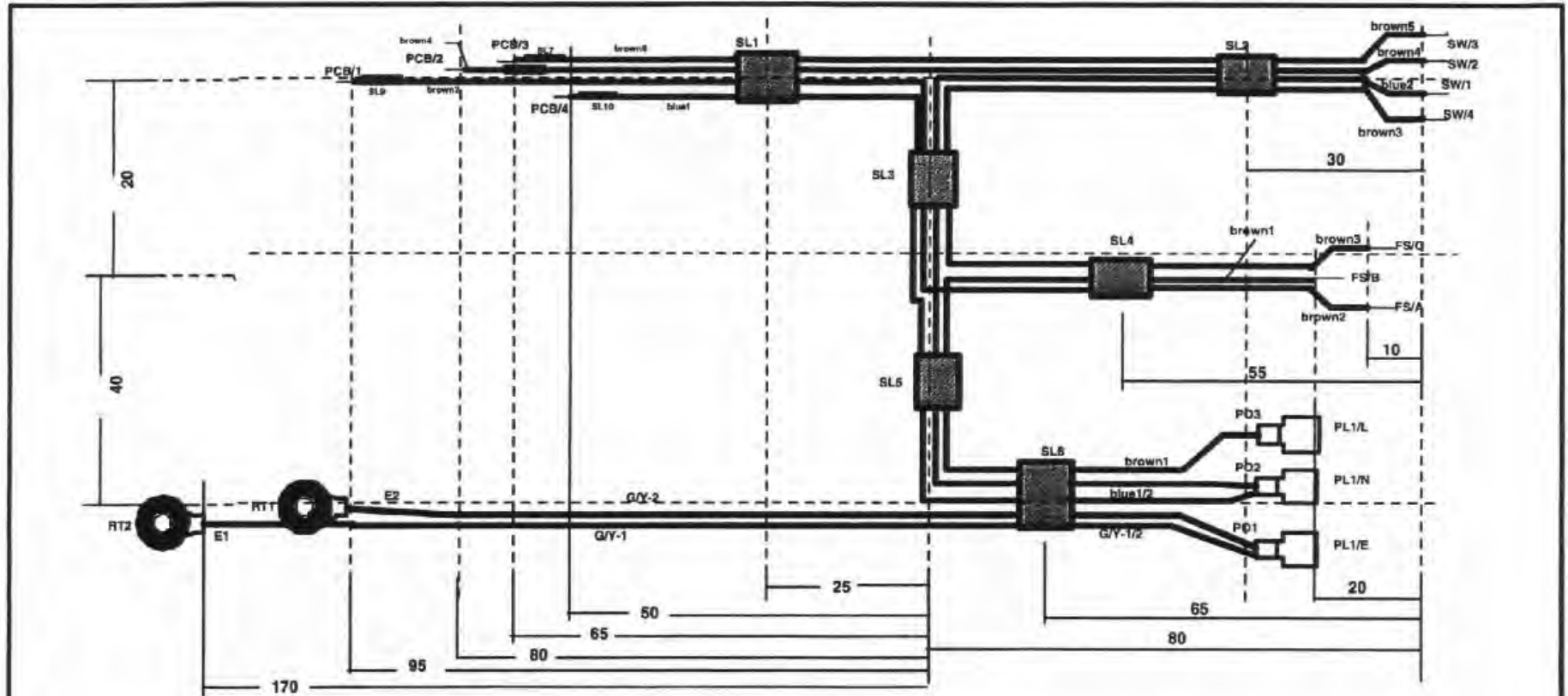

RT1/RT2 :- M3 RING TERMINAL TYPE THOMAS & BETTS DRB3Y (or equivalent i.e. Farnell 209-510).
 PO2/PO3 :- FULLY INSULATED PUSH-ON RED TYPE 6.3X0.8 (Farnell type 150-305 or equivalent).
 PO1 :- FULLY INSULATED PUSH-ON YELLOW TYPE 6.3X0.8 (Farnell type 150-308 or equivalent).
 SLEEVES SL1-SL6 :-HELLERMAN H30 BLACK. SLEEVES SL7-SL10 ARE TO BE HELLERMANN H12 BLACK (fitted but only used in final installation)
 TRI-RATED WIRE TYPES TO BS6231 ARE :-GRN/YELL 32/0.2, BROWN AND BLUE ARE 18/0.2.
 Note 1 :- All unterminated wires to be stripped and tinned 5mm min beyond specified lengths, and fitted with Z5 type cable markers.
 Cable markers to indicate wire destination as per Sheet 2 table. Fuse connection FS/B is 10mm shorter than FS/A/C.

Drawing Rev :- Wire Idents and Dimensions changed to simplify installation in final assembly.(Design change L075)

DRW:- BLMT0007.L21	TITLE :-	SHEET :- 1 OF 2	DRAWN :- B.PERRETT.
ISSUE :- 1.2	IEC/SELECT/FUSE LOOM. (Part L033FSL02IX)	TOL :- ±10%.	DATE :- 27.10.94.



PROJECTION :-

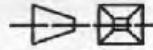

Frequency Standard Rear Panel Top



SELECT SWITCH (SW)
(view onto rear pins)



FUSE(FS)
(view onto rear pins)

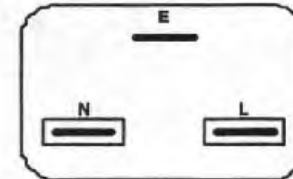

IEC MAINS PLUG (PL1)
(view onto rear pins)

START		WIRE TYPE (TRI-RATED)	COLOUR	FINISH	
FINAL CONNECTION	WIRE IDENT			WIRE IDENT	FINAL CONNECTION
PO1 (S1) TO IEC PLUG EARTH	PL1/E	32/0.2	GRN/YELL	E1	RT2 to PCB BOSS
		32/0.2	GRN/YELL	E2	RT1 to PANEL STUD
PO2 (S2) TO IEC PLUG NEUTRAL	PL1/N	16/0.2	BLUE-1	PCB/4	PCB/Pin4
		16/0.2	BLUE-2	SW/1	SW/TAB1
PO3 (S3) TO IEC LIVE	PL1/L	16/0.2	BROWN-1	FS/B	FS/PinB
FS/PinA	FS/A	16/0.2	BROWN-2	PCB/1	PCB/Pin1
FS/PinC	FS/C	16/0.2	BROWN-3	SW/4	SW/TAB4
SW/TAB2	SW/2	16/0.2	BROWN-4	PCB/2	PCB/Pin2
SW/TAB3	SW/3	16/0.2	BROWN-5	PCB/3	PCB/Pin3

Drawing Rev :- Wire Identa changed to reflect termination in final installation.(Design change L075).

DRW:- 8LMT0007.L2I

TITLE :-

SHEET:- 2 OF 2.

DRAWN :- B.PERRETT.

ISSUE :- 1.2

IEC/SELECT/FUSE LOOM. (Part L033FSL021X)

TOL :-

DATE :- 27.10.94.

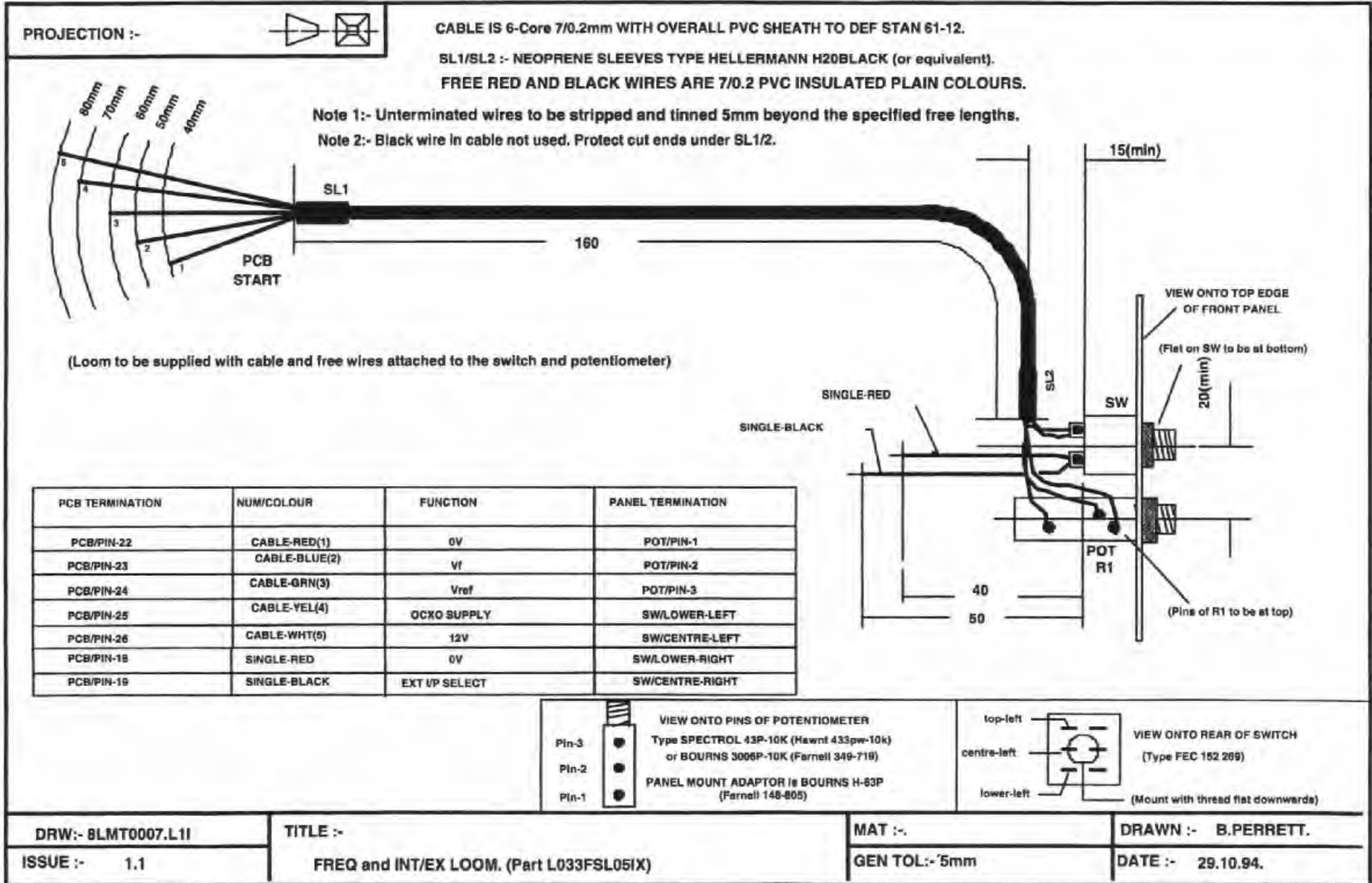



10 MHz Frequency Standard

PCB Parts List

Document No: LM030400022

Issue 1.5

Reference	Description	Stock Number
C1	0.15 μ F LEADED POLY 63V	L0669154OPFA0
C2	330pF LEADED CMC 100V 2%	L06693312NXA0
C4	100pF LEADED CMC 100V 2%	L06691012NXA0
C5	15pF LEADED CMC 100V 2%	L06691502NXA0
C6	220pF LEADED CMC 100V 2%	L06692212NXA0
C7	270pF LEADED CMC 100V 2%	L06692712NXA0
C8	33pF LEADED CMC 100V 2%	L06693302NXA0
C9	0.15 μ F LEADED POLY 63V	L0669154OPFA0
C10	330pF LEADED CMC 100V 2%	L06693312NXA0
C12	100pF LEADED CMC 100V 2%	L06691012NXA0
C13	15pF LEADED CMC 100V 2%	L06691502NXA0
C14	220pF LEADED CMC 100V 2%	L06692212NXA0
C15	270pF LEADED CMC 100V 2%	L06692712NXA0
C16	33pF LEADED CMC 100V 2%	L06693302NXA0
C17	0.15 μ F LEADED POLY 63V	L0669154OPFA0
C18	330pF LEADED CMC 100V 2%	L06693312NXA0
C20	100pF LEADED CMC 100V 2%	L06691012NXA0
C21	15pF LEADED CMC 100V 2%	L06691502NXA0
C22	220pF LEADED CMC 100V 2%	L06692212NXA0
C23	270pF LEADED CMC 100V 2%	L06692712NXA0
C24	33pF LEADED CMC 100V 2%	L06693302NXA0
C25	0.15 μ F LEADED POLY 63V	L0669154OPFA0
C26	330pF LEADED CMC 100V 2%	L06693312NXA0
C28	100pF LEADED CMC 100V 2%	L06691012NXA0
C29	15pF LEADED CMC 100V 2%	L06691502NXA0
C30	220pF LEADED CMC 100V 2%	L06692212NXA0
C31	270pF LEADED CMC 100V 2%	L06692712NXA0
C32	33pF LEADED CMC 100V 2%	L06693302NXA0
C33	0.15 μ F LEADED POLY 63V	L0669154OPFA0
C34	330pF LEADED CMC 100V 2%	L06693312NXA0
C36	100pF LEADED CMC 100V 2%	L06691012NXA0
C37	15pF LEADED CMC 100V 2%	L06691502NXA0
C38	220pF LEADED CMC 100V 2%	L06692212NXA0
C39	270pF LEADED CMC 100V 2%	L06692712NXA0
C40	33pF LEADED CMC 100V 2%	L06693302NXA0
C41	0.15 μ F LEADED POLY 63V	L0669154OPFA0
C42	330pF LEADED CMC 100V 2%	L06693312NXA0
C44	100pF LEADED CMC 100V 2%	L06691012NXA0
C45	15pF LEADED CMC 100V 2%	L06691502NXA0
C46	220pF LEADED CMC 100V 2%	L06692212NXA0
C47	270pF LEADED CMC 100V 2%	L06692712NXA0
C48	33pF LEADED CMC 100V 2%	L06693302NXA0
C49	0.15 μ F LEADED POLY 63V	L0669154OPFA0
C50	0.15 μ F LEADED POLY 63V	L0669154OPFA0
C51	0.15 μ F LEADED POLY 63V	L0669154OPFA0



C52	0.15uF LEADED POLY 63V	L0669154OPFA0
C53	0.15uF LEADED POLY 63V	L0669154OPFA0
C54	0.15uF LEADED POLY 63V	L0669154OPFA0
C55	0.15uF LEADED POLY 63V	L0669154OPFA0
C56	0.15uF LEADED POLY 63V	L0669154OPFA0
C57	0.15uF LEADED POLY 63V	L0669154OPFA0
C58	0.15uF LEADED POLY 63V	L0669154OPFA0
C59	0.15uF LEADED POLY 63V	L0669154OPFA0
C60	0.15uF LEADED POLY 63V	L0669154OPFA0
C61	0.15uF LEADED POLY 63V	L0669154OPFA0
C62	0.15uF LEADED POLY 63V	L0669154OPFA0
C63	0.15uF LEADED POLY 63V	L0669154OPFA0
C64	10uF LEADED TANT 16V 20%	L0669106BBCA0
C66	0.15uF LEADED POLY 63V	L0669154OPFA0
C67	0.15uF LEADED POLY 63V	L0669154OPFA0
C68	0.15uF LEADED POLY 63V	L0669154OPFA0
C69	0.15uF LEADED POLY 63V	L0669154OPFA0
C70	10uF LEADED TANT 16V 20%	L0669106BBCA0
C71	0.15uF LEADED POLY 63V	L0669154OPFA0
C72	10uF LEADED TANT 16V 20%	L0669106BBCA0
C73	0.15uF LEADED POLY 63V	L0669154OPFA0
C74	2200uF LEAD ELEC 63V 20%	L0669228AEXA0
C75	0.15uF LEADED POLY 63V	L0669154OPFA0
C76	1nF LEADED CMC 100V 10%	L0669102AXXA0
C77	1nF LEADED CMC 100V 10%	L0669102AXXA0
C78	1nF LEADED CMC 100V 10%	L0669102AXXA0
C79	1nF LEADED CMC 100V 10%	L0669102AXXA0
C80	1nF LEADED CMC 100V 10%	L0669102AXXA0
C81	1nF LEADED CMC 100V 10%	L0669102AXXA0
C82	0.15uF LEADED POLY 63V	L0669154OPFA0
D1	1N4148	L063C1N4148A0
D2	1N4148	L063C1N4148A0
D3	DIODE 1N4001	L063C1N4001A0
D4	DIODE 1N4001	L063C1N4001A0
D5	SKB2/02 BRIDGE	L063SKB202XA0
D7	1N4148	L063C1N4148A0
F2	FUSE 2A 20mm	L0722A20MMXA0
IC1	74AC00	L05774AC00PA0
IC2	74AC00	L05774AC00PA0
IC3	74AC00	L05774AC00PA0
IC4	74AC00	L05774AC00PA0
IC5	74HCU04 16 PIN DIL	L05774HCU04A0
IC6	LT1016	L057LT1016XA0
IC7	LM7805CT	L057LM7805CA0
IC8	LM7812CT	L057LM7812CA0
J1	VEROPIN	L035V18028BA0
J2	VEROPIN	L035V18028BA0
J3	VEROPIN	L035V18028BA0
J4	VEROPIN	L035V18028BA0
J6	VEROPIN	L035V18028BA0
J8	VEROPIN	L035V18028BA0
J10	VEROPIN	L035V18028BA0
J12	VEROPIN	L035V18028BA0
J14	VEROPIN	L035V18028BA0
J16	VEROPIN	L035V18028BA0
J18	VEROPIN	L035V18028BA0
J19	VEROPIN	L035V18028BA0
J21	VEROPIN	L035V18028BA0
J22	VEROPIN	L035V18028BA0
J23	VEROPIN	L035V18028BA0
J24	VEROPIN	L035V18028BA0
J25	VEROPIN	L035V18028BA0
J26	VEROPIN	L035V18028BA0



J27	VEROPIN	L035V18028BA0
J28	VEROPIN	L035V18028BA0
J29	PC MOUNT FUSE CLIP	L072PCMFCXXA0
J30	PC MOUNT FUSE CLIP	L072PCMFCXXA0
L1	680nH INDUCTOR	L0649687XXXA0
L2	680nH INDUCTOR	L0649687XXXA0
L3	680nH INDUCTOR	L0649687XXXA0
L4	680nH INDUCTOR	L0649687XXXA0
L5	680nH INDUCTOR	L0649687XXXA0
L6	680nH INDUCTOR	L0649687XXXA0
L7	680nH INDUCTOR	L0649687XXXA0
L8	680nH INDUCTOR	L0649687XXXA0
L9	680nH INDUCTOR	L0649687XXXA0
L10	680nH INDUCTOR	L0649687XXXA0
L11	680nH INDUCTOR	L0649687XXXA0
L12	680nH INDUCTOR	L0649687XXXA0
CCX01	HCD71	L055HCD71XXA0
PCB1	FREQUENCY STANDARD PCB	L001FSPCBXXA0
R1	500R 3386P	L0699501ACXA0
R2	500R 3386P	L0699501ACXA0
R3	500R 3386P	L0699501ACXA0
R4	500R 3386P	L0699501ACXA0
R5	500R 3386P	L0699501ACXA0
R6	500R 3386P	L0699501ACXA0
R7	10K LEADED 0.25W 1%	L06991031M4A0
R10	1M LEADED 0.25W 1%	L06991051M4A0
R11	4K7 LEADED 0.25W 1%	L06994721M4A0
R12	1K LEADED 0.25W 1%	L06991021M4A0
R13	51R LEADED 0.25W 1%	L06995101M4A0
R14	1K LEADED 0.25W 1%	L06991021M4A0
R16	10K LEADED 0.25W 1%	L06991031M4A0
R19	1M LEADED 0.25W 1%	L06991051M4A0
R20	51R LEADED 0.25W 1%	L06995101M4A0
R21	1K LEADED 0.25W 1%	L06991021M4A0
SW1	DPST DIL SWITCH	L051SWSPSTXA0
SW2	DPST DIL SWITCH	L051SWSPSTXA0
TRF1	0-9/0-9 TRANS 18VA	L00709018VAA0



10 MHz Frequency Standard

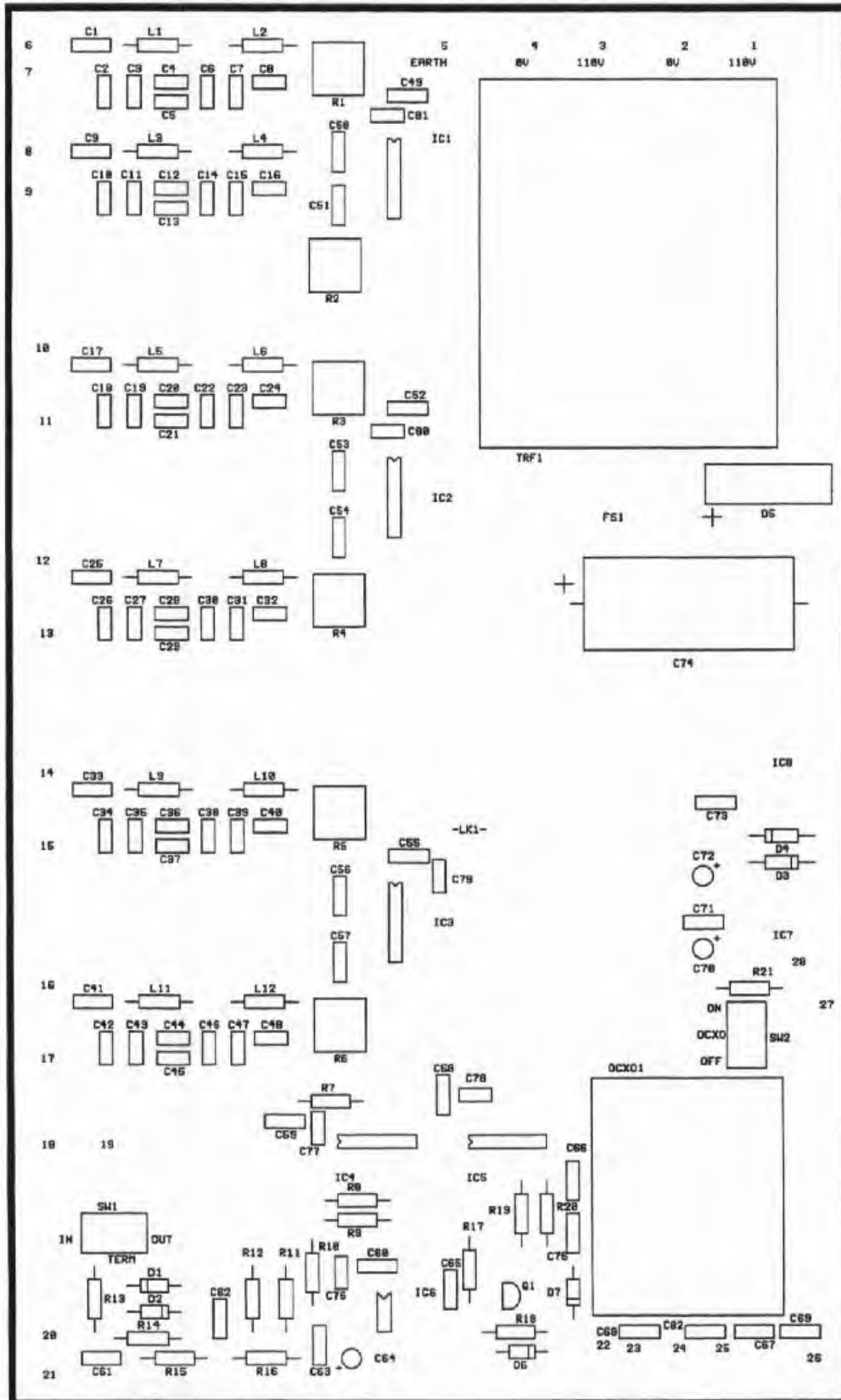

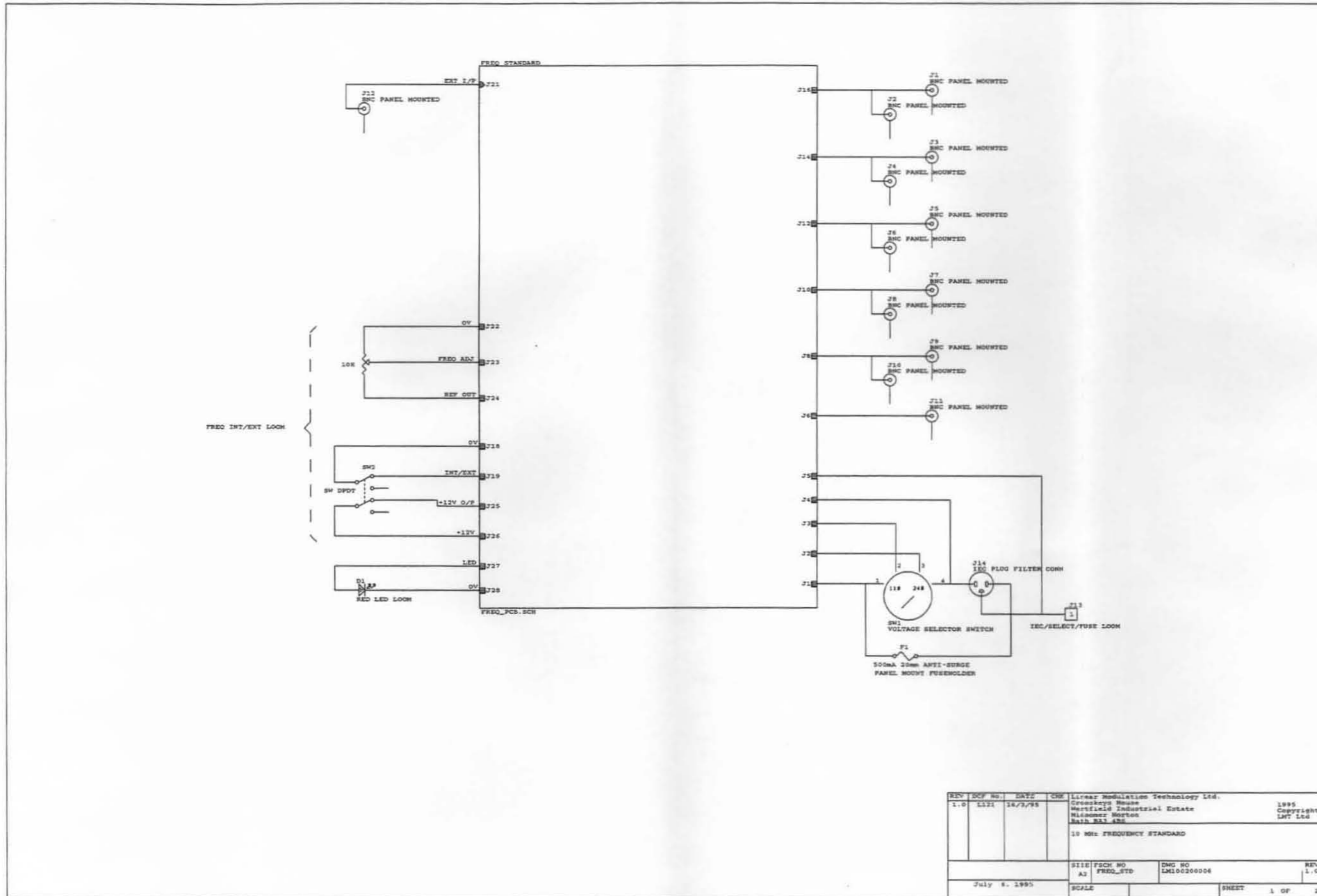

REV	DCP NO.	DATE	CHK	Linear Modulation Technology Ltd. Greenkyns House Westfield Industrial Estate Mickover Norton Bath BA1 4RS	1995 Copyright LMT Ltd
1.0	L121	14/3/95		10 MHz FREQUENCY STANDARD	
				SITE PCB NO A3 FREQ_STD	DWG NO LM100200004
July 8, 1995				SCALE	SHEET 1 OF 1

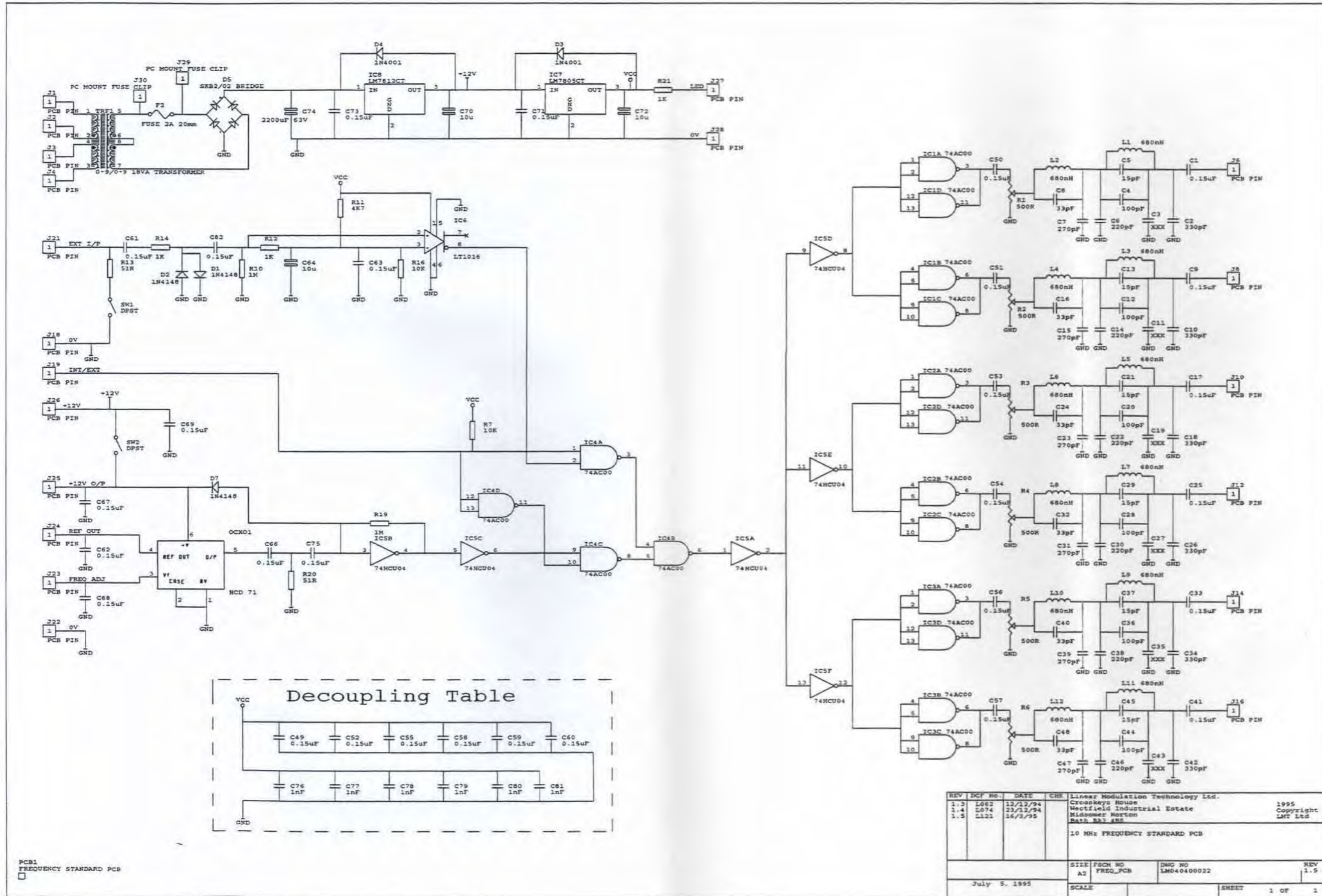

Decoupling Table

VCC	C49	C52	C55	C58	C59	C60
	0.15uF	0.15uF	0.15uF	0.15uF	0.15uF	0.15uF
	C76	C77	C78	C79	C80	C81
	1nF	1nF	1nF	1nF	1nF	1nF
GND						

REV	DCP No.	DATE	CHK	Linear Modulation Technology Ltd.	1995
1.3	L062	12/12/94		Croskeys House	Copyright
1.4	L074	23/12/94		Westfield Industrial Estate	Let Ltd
1.5	L121	16/3/95		Midsomer Norton	
				Bath BA3 4BB	
10 MHz FREQUENCY STANDARD PCB					
			SIZE	FSCN NO	DWG NO
			A2	FREQ_PCB	LM040400022
July 5, 1995			SCALE		REV
					1.5
				SHEET	1 OF 1



16. Channel Shelf 25 W / 100 W

Contents

General Assemblies.....	16-3
Chassis.....	16-3
Module Parts List.....	16-5
Looms.....	16-6
PA-EX Conns Loom.....	L033LPAEXXEA0..... 16-6
RX-TCC Data Loom.....	L033RXTCCCEXA0..... 16-7
PSU-TCC Power Loom.....	L033STC575EA1..... 16-8
PSU-RX Power Loom.....	L033SRX625EA1..... 16-9
PSU-PA Power Loom.....	L033SPA555EB1..... 16-10
PSU-EX Power Loom.....	L033SEX465EA1..... 16-11
PA-EX Feedback Loom.....	L033LA1E4XEA1..... 16-12
EX-TCC Data Loom.....	L033EXTCCCEXA0..... 16-13

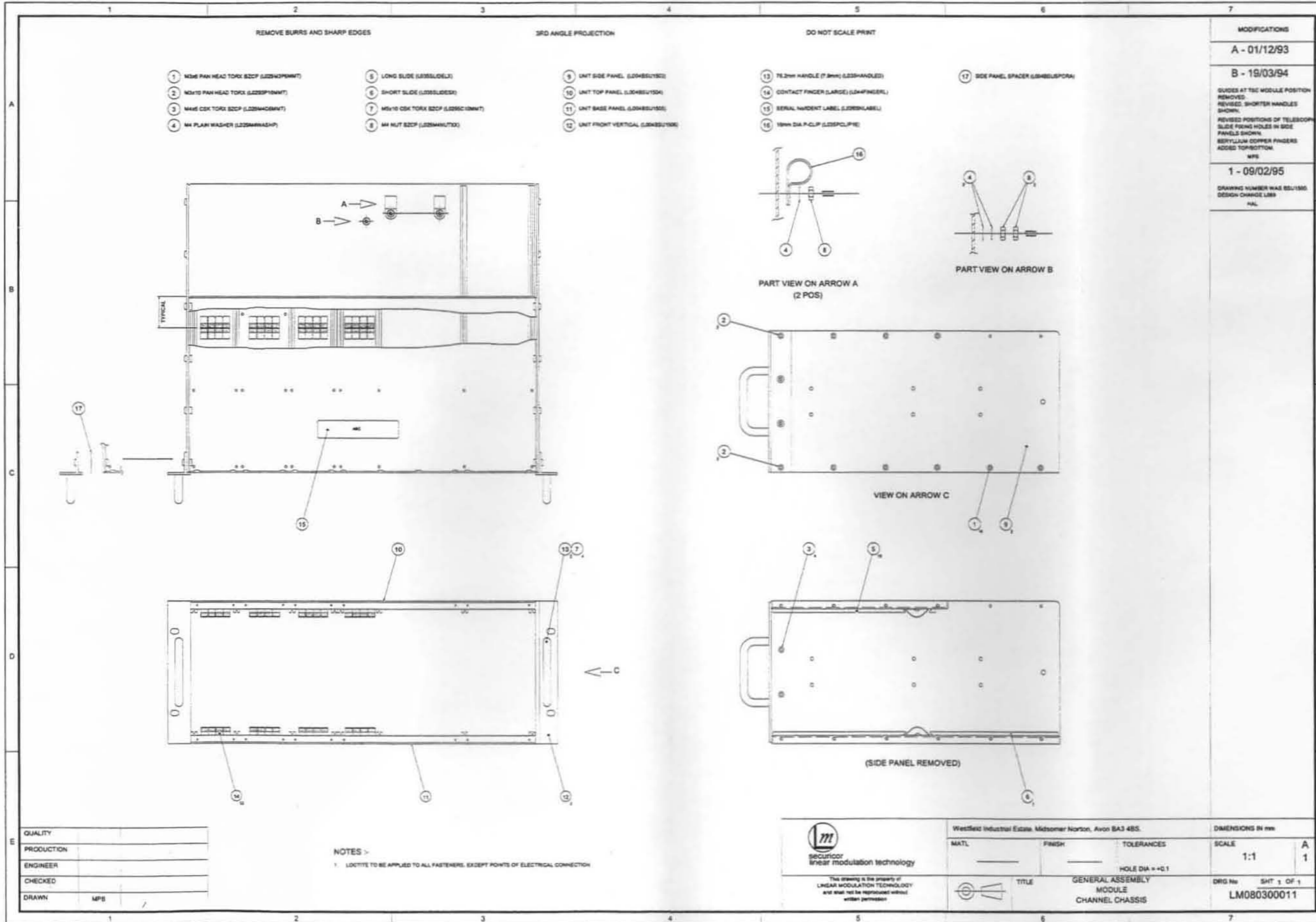



For - 8LMT0001

Module Parts List

1 shelf

Channel Chassis

Document No: LM030300011

Issue 1.0

Quantity	Description	Stock Number
2	UNIT SIDE PANEL	L004BSU1503B1
1	UNIT TOP PANEL	L004BSU1504A1
1	UNIT BASE PANEL	L004BSU1505A2
2	UNIT FRONT VERT	L004BSU1506A3
1	BASE STATION SHIM	L004BSUSHIMA0
1	SERIAL N/D LABEL	L026SNLABELB0
4	M3 X 10MM PAN HEAD TORX	L0293P10MMTA0
4	M5X10 CSK TORX BZCP	L0295C10MMTA0
20	FRONT SCREW	L029FSCREWXA0
16	M3X6 PAN HEAD TORX BZCP	L029M3P6MMTA0
4	M4X6 CSK TORX BZCP	L029M4C6MMTA0
4	M4 NUT BZCP	L029M4NUTXXA0
4	M4 PLAIN WASHER	L029M4WASHPA0
2	M4 SHAKEPROOF WASHER	L029M4WASHSA0
1	PSU - CHASSIS E/LOOM	L033CEL47EXA0
1	EX-TCC DATA LOOM	L033EXTCCEXA0
2	PA-EX FEEDBACK LOOM	L033LA1E4XE1
1	PA-EX CONNS LOOM	L033LPAEXXE1
1	RX-TCC DATA LOOM	L033RXTCCCEXA0
1	PSU-EX POWER LOOM	L033SEX465EA1
1	PSU-PA POWER LOOM	L033SPA555EB1
1	PSU-RX POWER LOOM	L033SRX625EA1
1	PSU-TCC POWER LOOM	L033STC575EA1
2	76.2mm HANDLE M5X8 FIX	L035HANDLEDA0
2	16mm DIA P-CLIP	L035PCLIP16A0
16	LONG SLIDE	L035SLIDELXA0
2	SHORT SLIDE	L035SLIDESXA0
32	CONTACT FINGERS LARGE	L044FINGERLA0



PROJECTION :-

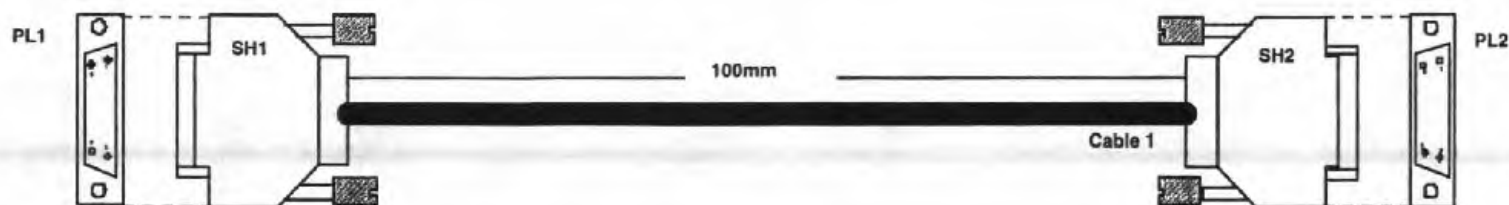

START PL1	SEPARATION 100mm	FINISH/1 PL2
PIN	FUNCTION	PIN
1	REVERSE	1
6	FORWARD	6
2	(-) 8V	2
7	(+)8V	7
3	BATTERY MON	3
8	PA ENABLE	8
4	TX/NRX	4
9	N/U	9
5	PA TEMP	5

PL1/PL2 :- Solder Bucket Plug 9-way ITT ADE9K87 (or Farnell 105-505).

SH1/2:- Shrouds type HARTING DTZK-09 (or Farnell 240-254)

CABLE 1 :- 8-Core Screened 7/0.2 to BS6746. Free length 100mm.

Note :- Screens of cable to be wrapped at each connector earth compression ring.

DRW:- 8LMT0001.L2I	TITLE :- PA-EX CONNS LOOM. (Part L033LPAEXXE)	MAT :-	DRAWN :- B.PERRETT.
ISSUE :- 1.0		FIN :-	DATE :- 18.4.94.

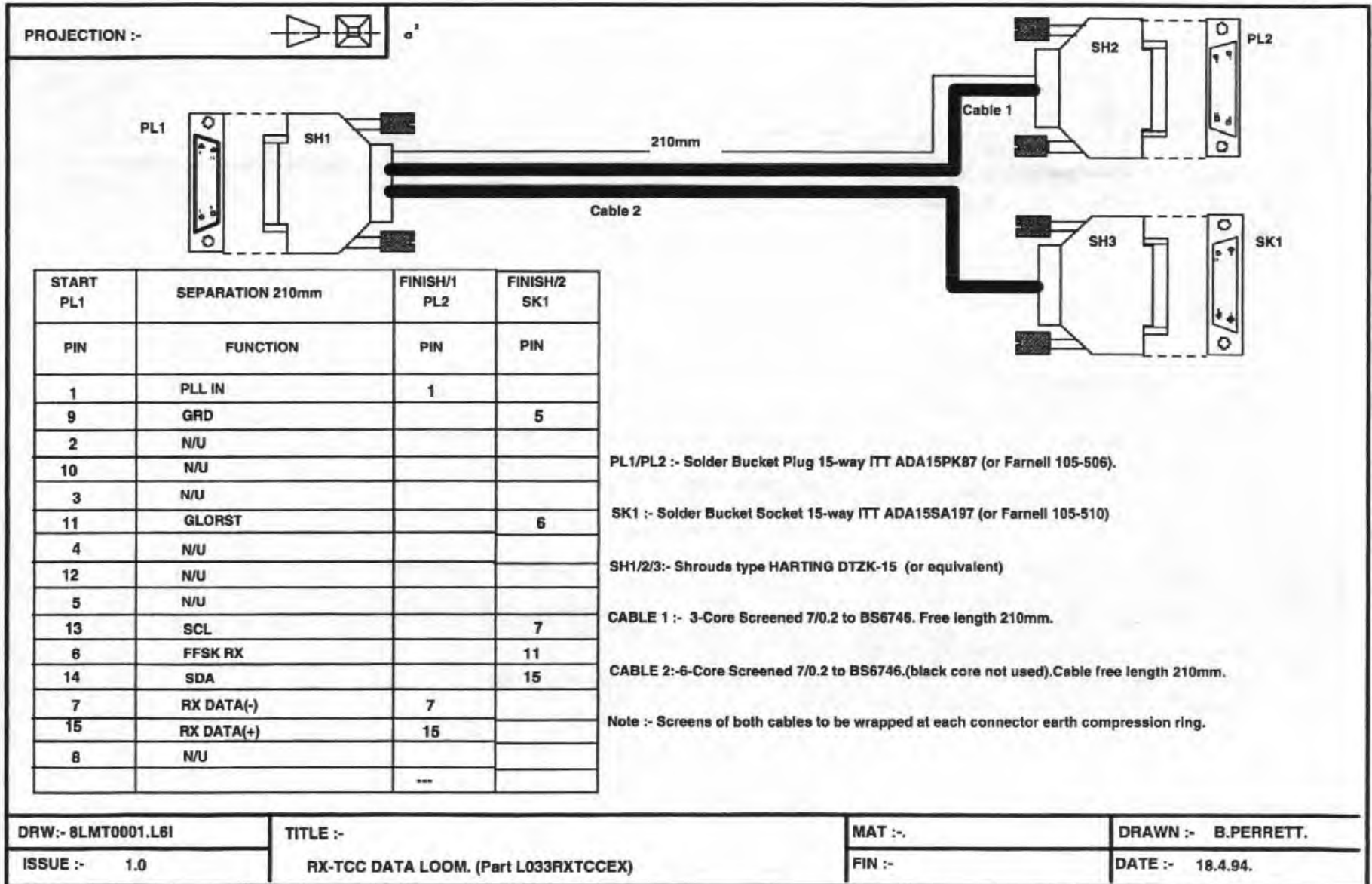



PROJECTION :-

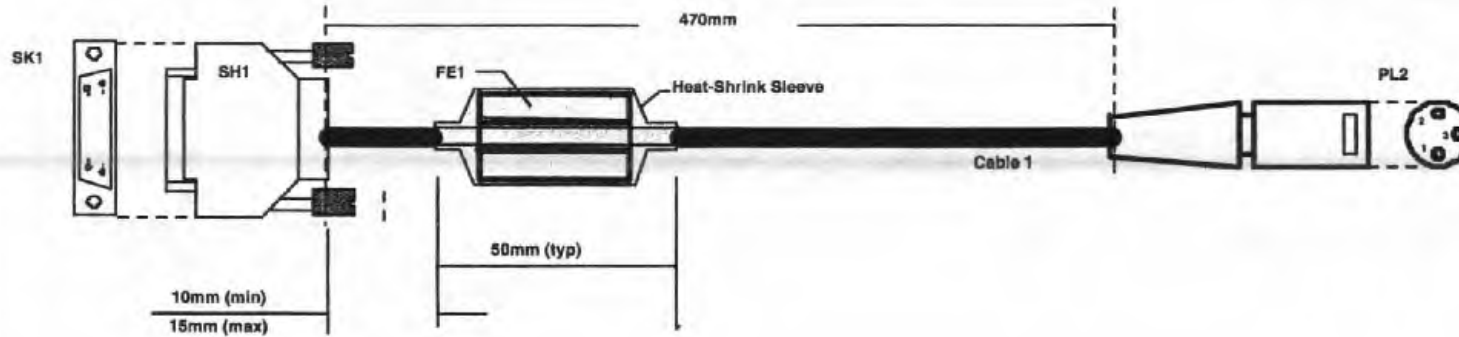
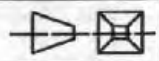

START SK1	SEPARATION 470mm	FINISH PL2
PIN	FUNCTION	PIN
1	12V	2
6	0V	1
2	12V	2
7	0V	1
3	12V	2
8	0V	1
4	12V	2
9	0V	1
5	12V	2

SK1 :- Solder Bucket Socket 9-way ITT ADE9SA197 (Farnell 105-509).

SH1:- Shroud type HARTING DTZK-09 (or Farnell 240-254)

PL2:- XLR style circular audio type NC3MX (or equivalent)

FE1:- Ferrite EMI Absorber type CHOMERICS 2880666-200 (or equivalent)

CABLE 1 :- 3-Core 24/0.2 mains flex to BS6746.(Farnell 152-412 or equivalent).

Note 1:- At SK1 link pins 6/7/8/9 and also link pins 1/2/3/4/5.

Note 2:- Pre-load FE1 prior to loom assembly and secure position with 3:1 Heat-Shrink Tubing of 19mm.(Farnell 236-275 or similar).

Modifications

A1 - 14/MAR/95.
Heat-Shrink used in place of Lacing.
Pos data added.
Drawing Number was 8LMT0001.L8I
Issue 1.0.
DCF L121 (BRP).

DRW:- L033STC575E

TITLE :-

MAT :-

DRAWN :- B.PERRETT.

ISSUE :- A1

PSU-TCC POWER LOOM.

GEN TOL :- 10%

DATE :- 18.4.94.

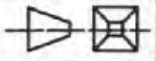

PROJECTION :- 

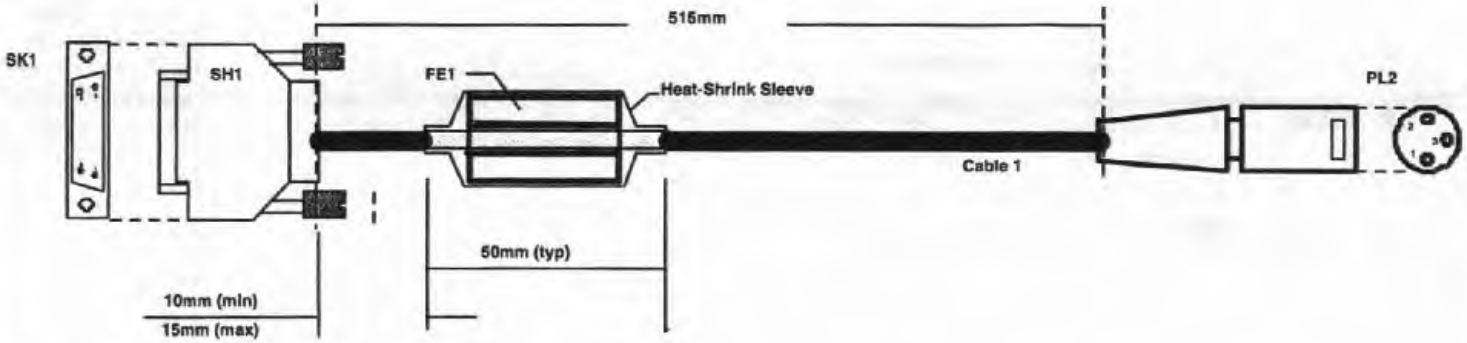

START SK1	SEPARATION 515mm	FINISH PL2
PIN	FUNCTION	PIN
1	12V	2
6	0V	1
2	12V	2
7	0V	1
3	12V	2
8	0V	1
4	12V	2
9	0V	1
5	12V	2

SK1 :- Solder Bucket Socket 9-way ITT ADE9SA197 (Farnell 105-509).

SH1:- Shroud type HARTING DTZK-09 (or Farnell 240-254)

PL2:- XLR style circular audio type NC3MX (or equivalent)

FE1:- Ferrite EMI Absorber type CHOMERICS 2880686-200 (or equivalent)

CABLE 1 :- 3-Core 24/0.2 mains flex to B96746.(Farnell 152-412 or equivalent).

Note 1:- At SK1 link pins 6/7/8/9 and also link pins 1/2/3/4/5.

Note 2:- Pre-load FE1 prior to loom assembly and secure position with 3:1 Heat-Shrink Tubing of 19mm.(Farnell 236-275 or similar).

DRW:- L033SRX625E	TITLE :- PSU-RX POWER LOOM.	MAT :-	DRAWN :- B.PERRETT.
ISSUE :- A1		GEN TOL :- 10%	DATE :- 18.4.94.

Modifications

A1 - 14/MAR/95.
Heat-Shrink used in place of Lacing.
Pos data added.
Drawing Number was 8LMT0001.L71
Issue 1.0.
DCF L121 (BRP).



PROJECTION :-

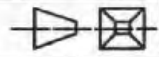

Modifications

B1 - 14/MAR/95.
Heat-Shrink used
in place of Lacing.
Pos data added.
Drawing Number
was 8LMT0001.L4I
Issue 1.2.
DCF L121 (BRP).

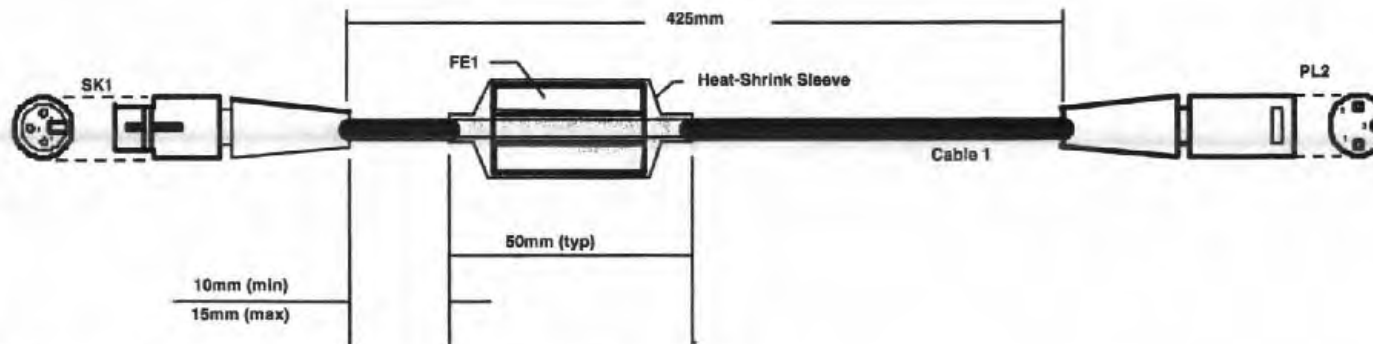

START SK1	SEPARATION 425mm	FINISH PL2
PIN	FUNCTION	PIN
1	0V (Green/Yel)	1
2	12V (Blue)	2
3	28V (Brown)	3

SK1 :- XLR style circular audio type NC3FX (or equivalent).

PL2:- XLR style circular audio type NC3MX (or equivalent)

FE1:- Ferrite EMI Absorber type CHOMERICS 2880686-200 (or equivalent)

CABLE 1 :- 3-Core 32/0.2 mains flex to BS6500.(Farnell 436-719 or equivalent).

Note 1:- Pre-load FE1 prior to loom assembly and secure position with
3:1 Heat-Shrink Tubing of 19mm.(Farnell 236-275 or similar).

DRW:- L033SPA555E.

TITLE :-

MAT :-

DRAWN :- B.PERRETT.

ISSUE :- B1

PSU-PA POWER LOOM.

GEN TOL :- 10%

DATE :- 18.4.94.

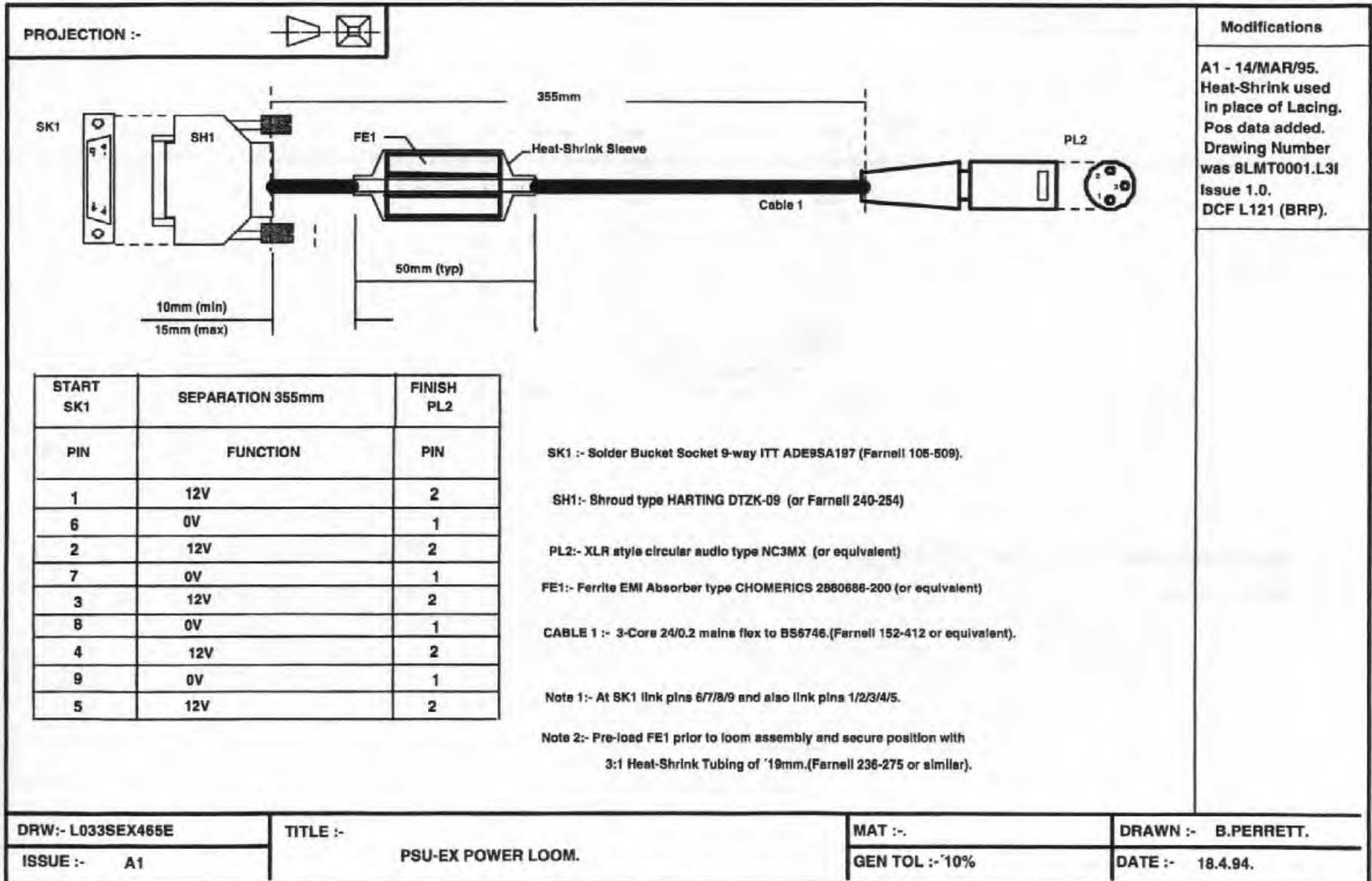

Modifications

A1 - 14/MAR/95.
Heat-Shrink used in place of Lacing.
Pos data added.
Drawing Number was 8LMT0001.L3I
Issue 1.0.
DCF L121 (BRP).



PROJECTION :-

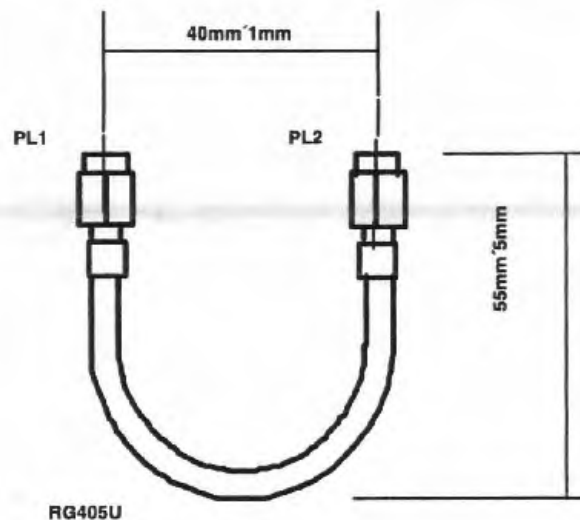
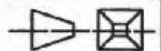

PL1/PL2 :- SMA CONNECTORS TYPE STRAIGHT PLUG M/A-COM2001-5032-02 (or equivalent).

CABLE IS RG405U

Drawing revision 13/12/94 :- Semi-rigid cable RG405 was flexible RG223 / Connectors now direct solder types were SMA crimp elbow types

DRW:- 8LMT0001.L5I

TITLE :-

MAT :-

DRAWN :- B.PERRETT.

ISSUE :- 1.1

PA-EX FEEDBACK LOOM. (Part L033LA1E4XE)

FIN :-

DATE :- 18.4.94.

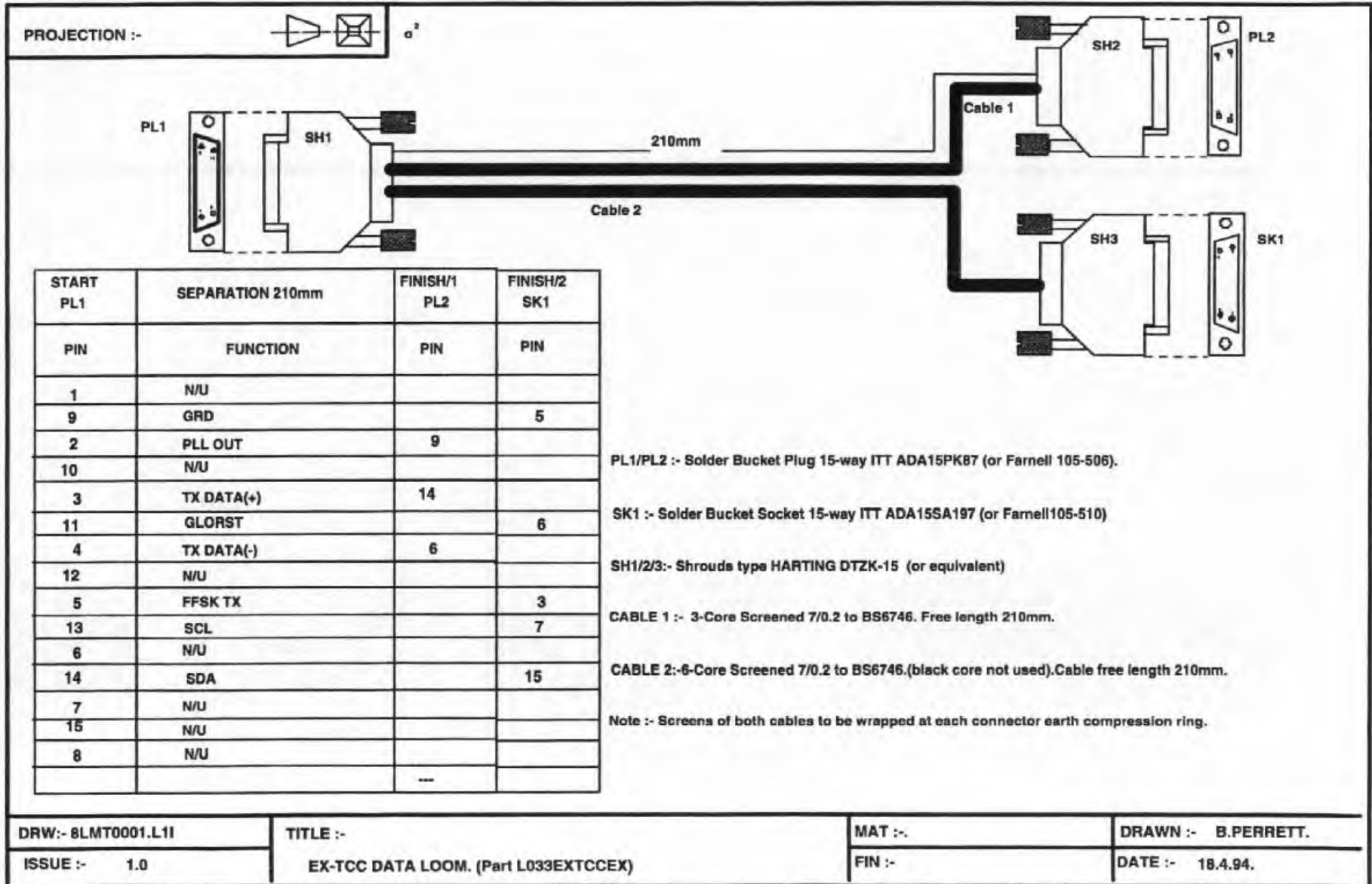



17. Power Amplifier 25 W

Contents

General Assemblies	17-3
Chassis.....	17-3
Module Parts List	17-5
Looms	17-7
TX Out Loom.....	L033PALPA3IA0..... 17-7
RF Feedback Loom.....	L033PALPA1IA0..... 17-8
4 to 4 Way IDC Loom.....	L0334WLOOM1A0..... 17-9
Power Loom.....	L033PALPA8IA0..... 17-10
DC Power Loom.....	L033PALPA5IA0..... 17-11
PA Drive Loom.....	L033PALPA2IA0..... 17-12
PA Conns Loom.....	L033PALPA4IB0..... 17-13
Red LED Loom.....	L033PALPA6IA0..... 17-14
Green LED Loom.....	L033PALPA7IA0..... 17-15
PCB Parts List	17-16
Main.....	17-16
Filter.....	17-19
Overlays	17-20
Main.....	17-20
Filter.....	17-21
Circuit Diagrams	17-23
PA 25 W Main.....	17-23
PA 25 W Filter.....	17-25



Module Parts List

USA 220 Channel Power Amplifier 25 W

Document No: LM030301007

Issue 1.1

Quantity	Description	Stock Number
1	PA HOUSING	L004BPA1303B1
1	PA FRONT PANEL	L004BPA1304B0
1	PA PLENUM	L004BPA1305A0
1	PA HEATSINK	L004BPA1306B1
1	SIDE PANEL	L004BSH1004A0
1	M3 RED RING CRIMP	L013M3RCRIMA0
1	SMB SOCKET PC MOUNT	L013SMBSKPCA0
1	BLACK BORDER LABEL	L026BBLABELA0
1	SERIAL N/D LABEL	L026SNLABELB0
2	102mm CABLE TIE	L029102TIESA0
11	M2.5X6 P/HEAD TORX BZCP	L02925P6MMTA0
4	M4X20 PAN HEAD TORX BZCP	L0294P20MMTA0
10	M3 5mm MALE-MALE SPACE	L0295MSPACEA0
34	M3X6 CSK TORX BZCP	L029M3C6MMTA0
11	M3 CRINKLE WASHER	L029M3CWASHA0
10	M3 NUT BZCP	L029M3NUTXXA0
7	M3X6 PAN HEAD TORX BZCP	L029M3P6MMTA0
2	M3-UNC4 LOCKING SCREWS	L029M3UNCLSA0
7	M3 PLAIN WASHER BZCP	L029M3WASHPA0
5	M3 SHAKEPROOF WASHER	L029M3WASHSA0
4	M4 NUT BZCP	L029M4NUTXXA0
12	M4 PLAIN WASHER	L029M4WASHPA0
4	M4 SHAKEPROOF WASHER	L029M4WASHSA0
1	SLEEVE 3 x 20 RUBBER	L0323X20SLVA0
2	4 TO 4 WAY IDC LOOM	L0334WLOOM1A0
1	RF FEEDBACK LOOM	L033PALPA1IA0
1	PA DRIVE LOOM	L033PALPA2IA0
1	TX OUT LOOM	L033PALPA3IA0
1	PA CONNS LOOM	L033PALPA4IB0
1	DC POWER LOOM	L033PALPA5IA0
1	RED LED LOOM	L033PALPA6IA0
1	GREEN LED LOOM	L033PALPA7IA0
1	POWER LOOM	L033PALPA8IA0
1	FAN 12V 80mm SQ	L03512VFANXA0
1	75.2mm HANDLE M3X8 FIX	L035HANDLEMA0
2	S/A C/TIE CLAMP	L035SATIECLA0
1	HEATSINK COMPOUND	L041HSCOMPXA0
1	1000PF FILTER CON	L066PC1000PA0

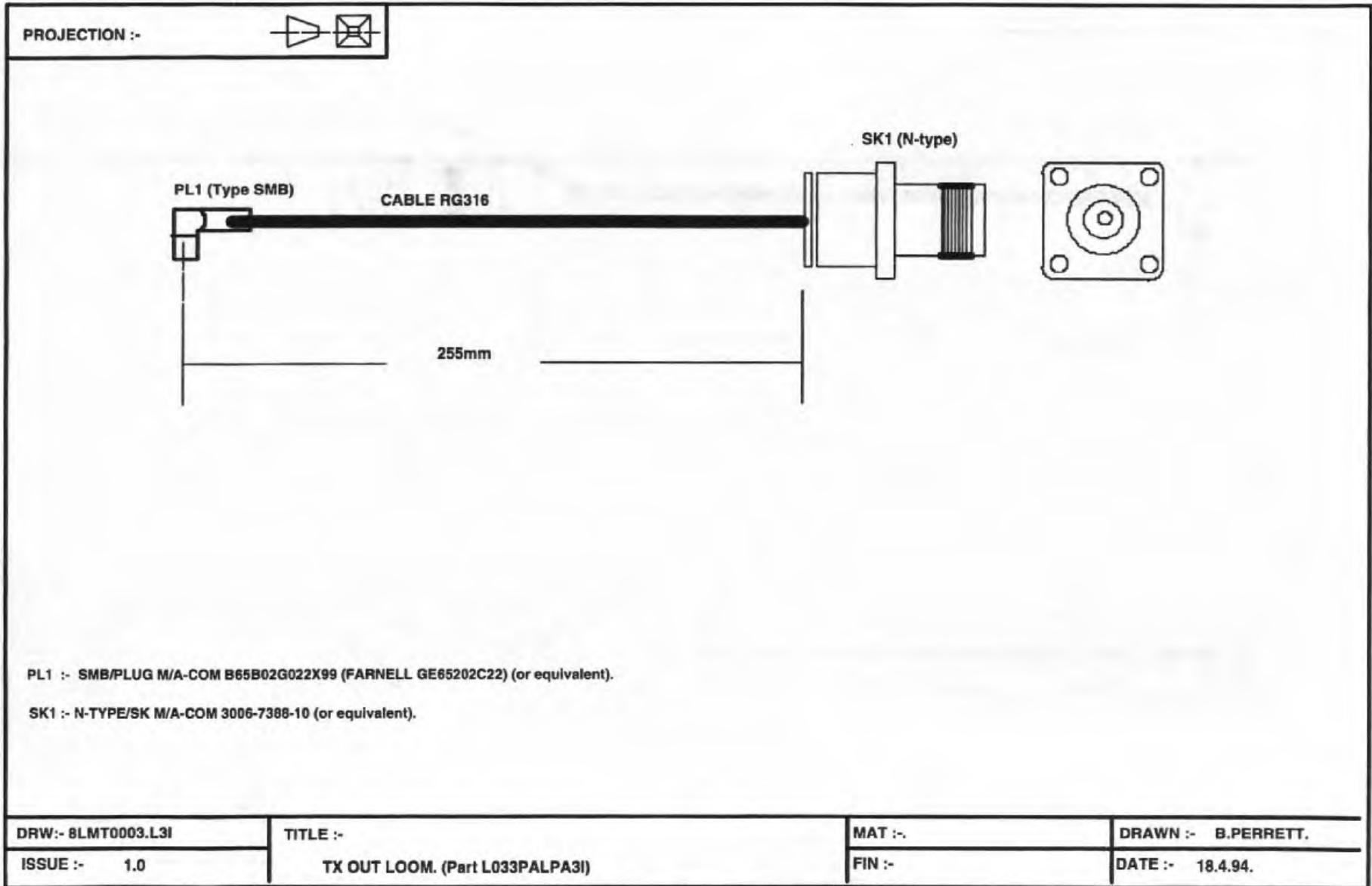



PROJECTION :-

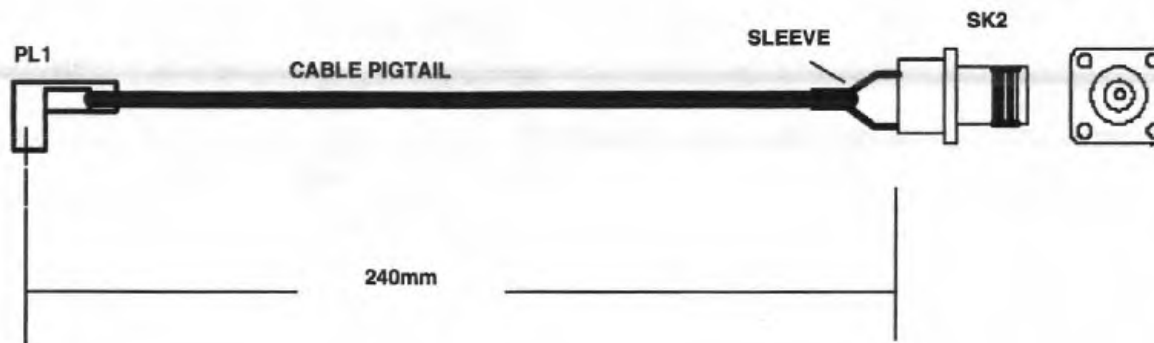
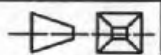

PL1/CABLE :- OMNI SPECTRA OSMT ANGLE JACK CABLE PIGTAIL 9950-2300-23 (or equivalent).

SK2 :- SMA/SK TYPE M/A-COM 2036-5016-00 (or equivalent).

DRW:- 8LMT0003.L11	TITLE :-	MAT :-	DRAWN :- B.PERRETT.
ISSUE :- 1.0	RF FEEDBACK LOOM. (Part L033PALPA11)	FIN :-	DATE :- 18.4.94.

POWER AMPLIFIER 25 W



1	2	3	4	5	6	7	
REMOVE BURRS AND SHARP EDGES		90° ANGLE PROTECTION		DO NOT SCALE PRINT			SPECIFICATIONS
Table: 4		Issue: B		Date: 25/6/93			AD - 25JUN/93 WIRE SPECIFIED 8993
Assembly: Base Station		Part: LOOM 1		Type: CRIMP			
Start Connector: SK1 Type: STOCKO MKH8124-1-0-400		Interface: RFU/PA Separation: 25mm		Finish Connector: SK2 Type: STOCKO MKH8124-1-0-400			
Pin	Wire	Electrical Function	Wire	Pin			
1	RED	Battery Monitor	RED	1			
2	GREY	P.A. Enable	GREY	2			
3	GREY	Tx / Rx	GREY	3			
4	GREY	P. A. Temp.	GREY	4			

NOTES:

- SK1/SK2 ARE SOCKET CONNECTORS WITH CRIMP CONNECTIONS. HOUSINGS ARE 'STOCKO' TYPE MKH8124-1-0-400. CRIMP CONNECTORS ARE 'STOCKO' TYPE RFB8002.003
- WIRE TO BE PVC TO DEF 61-12 (PART 6) SIZE 10/0.1 (MAX. OUTSIDE DIAMETER 1.10).

QUALITY PRODUCTION ENGINEER CHECKED DRAWN	[Blank space for signatures]	 linear modulation technology	Wireflex Industrial Estate, Midsummer Norton, Avon BA2 4BS DATE: _____ FINISH: _____ TOLERANCES: _____ TITLE: 4 TO 4 WAY IDC LOOM	DIMENSIONS in mm SCALE: 2:1 DISG Au BIT 1 OF 1 L0334WLOOM1
---	------------------------------	----------------------------------	---	---



PROJECTION :-

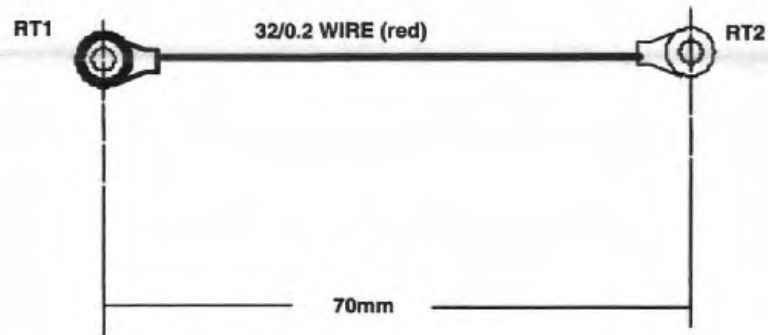

RT1/RT2 :- M3 RING TERMINALS TYPE THOMAS AND BETTS DRA3Y (or equivalent i.e. Farnell 150-268).

WIRE TYPE :- TRI-RATED BS6231 SIZE 32/0.2 RED INSULATION.

DRW:- 8LMT0003.L8I	TITLE :-	MAT :-	DRAWN :- B.PERRETT.
ISSUE :- 1.0	POWER LOOM. (Part L033PALPA8I)	FIN :-	DATE :- 18.4.94.

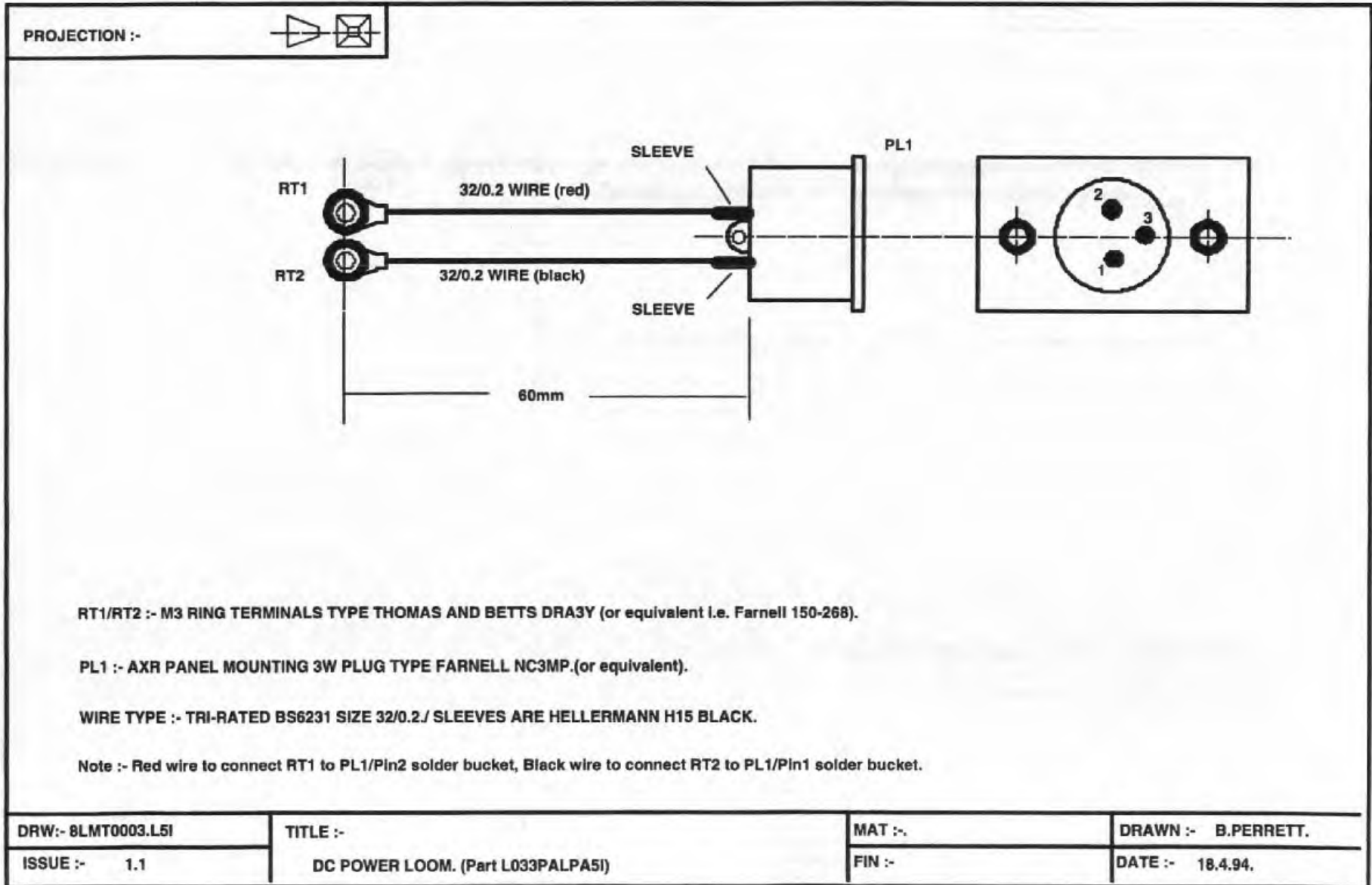



PROJECTION :-

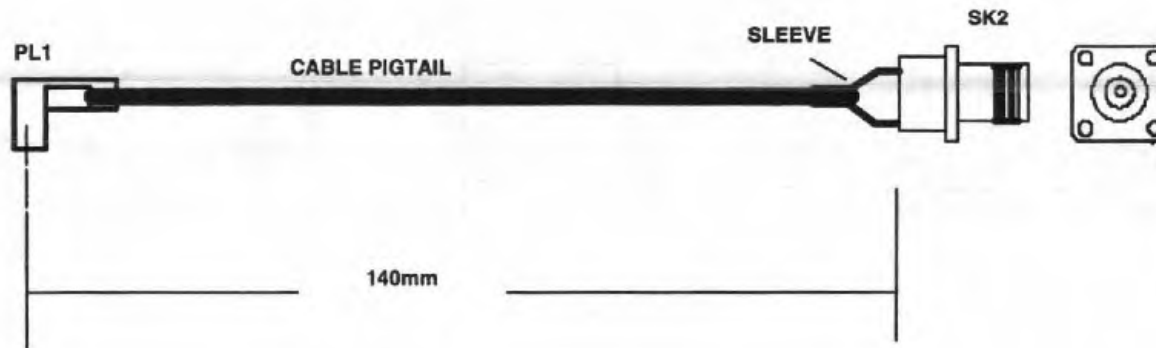

PL1/CABLE :- OMNI SPECTRA OSMT ANGLE JACK CABLE PIGTAIL 9950-2300-23 (or equivalent).

SK2 :- SMA/SK TYPE M/A-COM 2036-5016-00 (or equivalent).

DRW:- 8LMT0003.L2I

TITLE :-

MAT :-

DRAWN :- B.PERRETT.

ISSUE :- 1.0

PA DRIVE LOOM. (Part L033PALPA2I)

FIN :-

DATE :- 18.4.94.

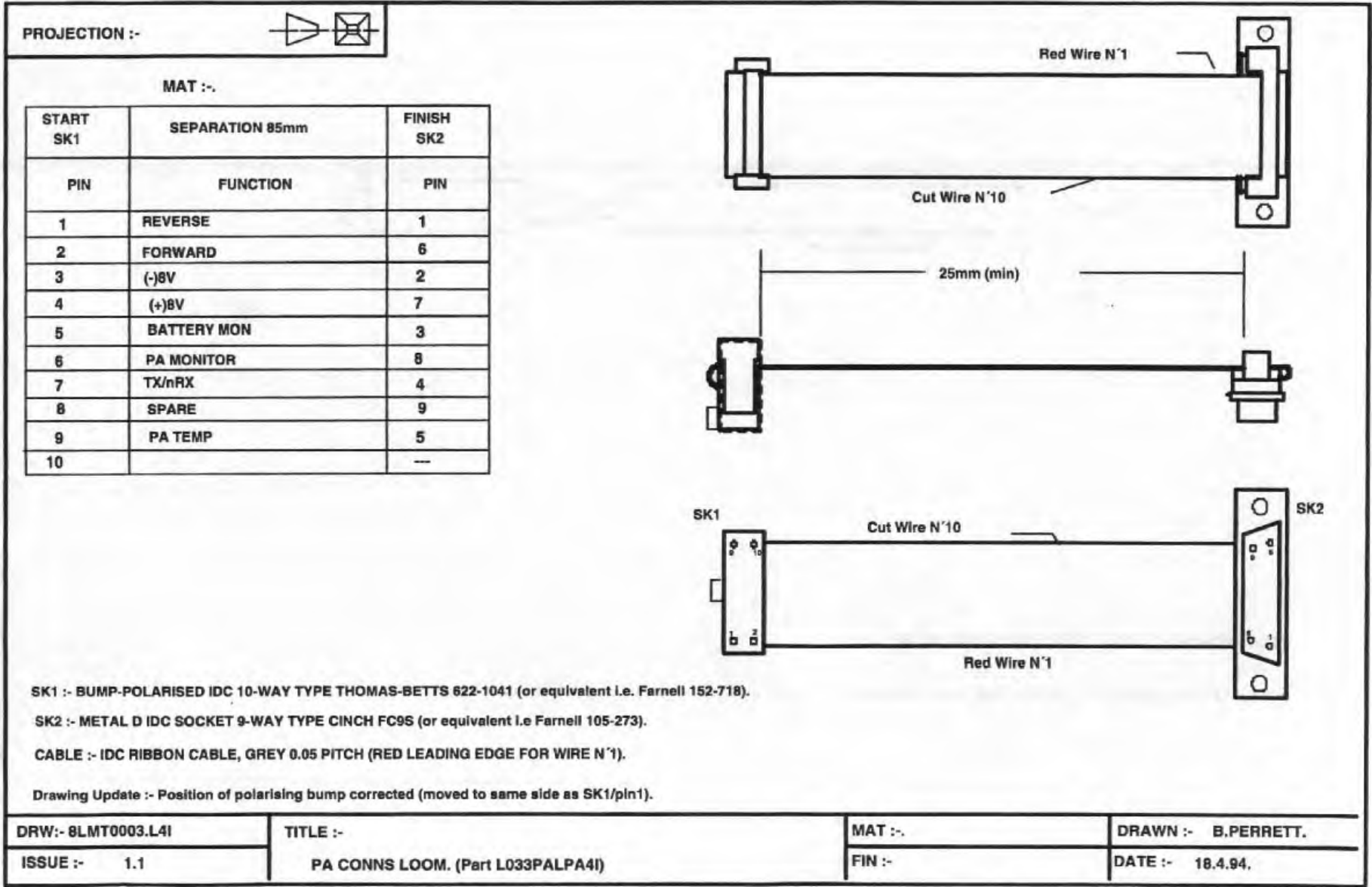



PROJECTION :-

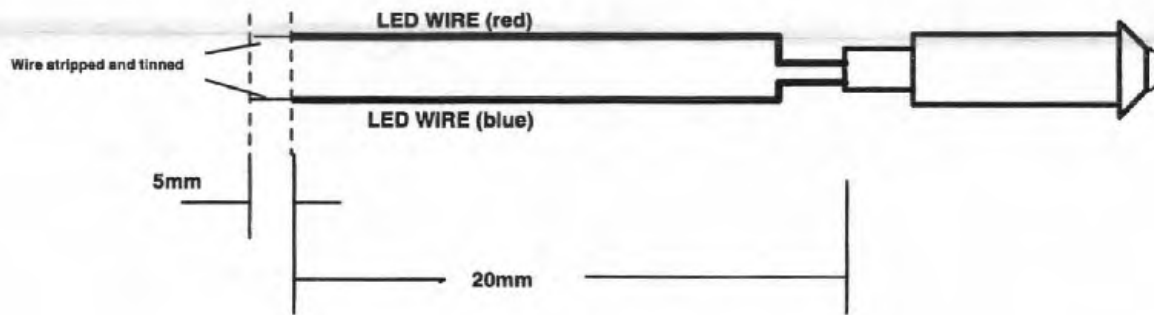
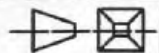

PANEL MOUNTING LED :- TYPE HERO SMRD 080-82.

NOTE :- LED is supplied with red and blue wires attached. Wires must be cut to specified length and stripped and tinned.

Previous drawing issue had ring terminals now deleted

DRW:- 8LMT0003.L6I	TITLE :- RED LED LOOM. (Part L033PALPA61)	MAT :-	DRAWN :- B.PERRETT.
ISSUE :- 1.1		FIN :-	DATE :- 18.4.94.

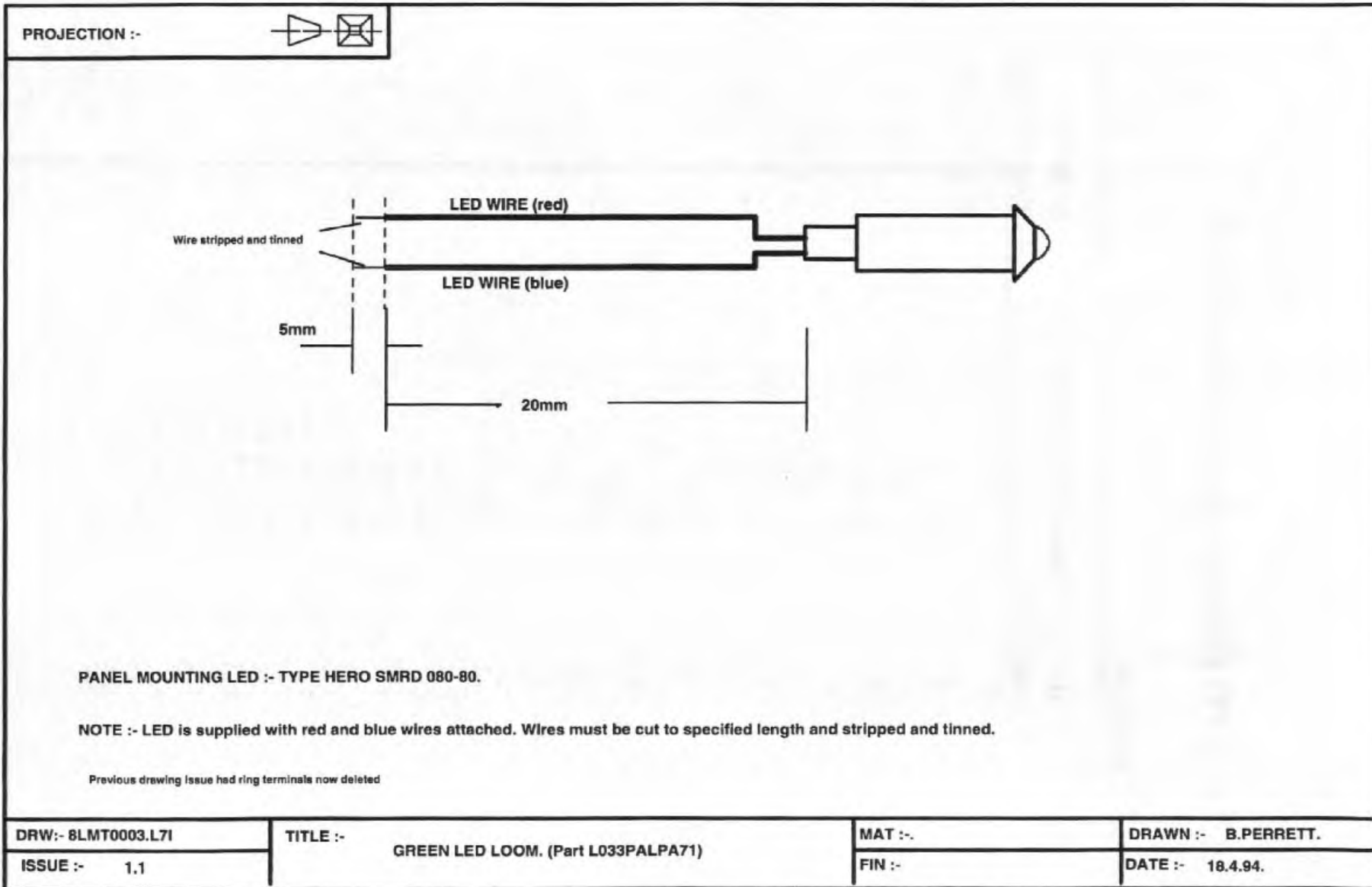



USA 220 Power Amplifier 25W

PCB Parts List

Document No: LM030401007

Issue 2.4

Reference	Description	Stock Number
C1	CAP 1nF NPO ±10% 0805	L0673102ANGA0
C2	CAP 1nF NPO ±10% 0805	L0673102ANGA0
C3	CAP 33pF NPO ±5% 0805	L06733305NGA0
C4	CAP 27pF NPO ±5% 0805	L06732705NGA0
C5	CAP 1nF NPO ±10% 0805	L0673102ANGA0
C6	CAP 12pF NPO ±5% 0805	L06731205NGA0
C7	CAP 15pF NPO ±5% 0805	L06731505NGA0
C8	CAP 15pF NPO ±5% 0805	L06731505NGA0
C9	CAP 2p2 NPO ±5% 0805	L067322Z5NGA0
C10	CAP SM ELEC 33uF 25V 20%	L067D336BEEA0
C11	CAP 10nF X7R ±10% 0805	L0673103AXGA0
C12	CAP 1nF NPO ±10% 0805	L0673102ANGA0
C13	CAP 10nF X7R ±10% 0805	L0673103AXGA0
C14	CAP 1nF NPO ±10% 0805	L0673102ANGA0
C15	CAP 2p2 NPO 5% 1206	L067422Z5NGA0
C16	CAP 2-18pF 809 05217	L06669180AVQA0
C17	CAP 1nF NPO ±10% 0805	L0673102ANGA0
C18	CAP 10nF X7R ±10% 0805	L0673103AXGA0
C19	CAP ELECT 1200uF 25V 20%	L0666PL1E122A0
C20	CAP 10nF X7R ±10% 0805	L0673103AXGA0
C21	CAP 10nF X7R ±10% 0805	L0673103AXGA0
C22	CAP 10nF X7R ±10% 0805	L0673103AXGA0
C23	CAP 100nF X7R ±10% 1206	L0674104AXGA0
C24	CAP 100nF X7R ±10% 1206	L0674104AXGA0
C25	CAP 12pF NPO ±5% 1206	L06741205NGA0
C26	CAP 10pF NPO ±5% 1206	L06741005NGA0
C27	CAP 15pF NPO ±5% 1206	L06741505NGA0
C28	CAP 15pF NPO ±5% 1206	L06741505NGA0
C29	CAP 18pF NPO 5% 1206	L06741805NGA0
C30	CAP 15pF NPO ±5% 1206	L06741505NGA0
C31	CAP 12pF NPO ±5% 1206	L06741205NGA0
C32	CAP 10pF NPO ±5% 1206	L06741005NGA0
C33	CAP 1pF NPO ±5% 1206	L067410Z5NGA0
C34	CAP 6p8 NPO 5% 0805	L067368Z5NGA0
C35	CAP 1nF NPO ±10% 0805	L0673102ANGA0
C36	CAP 1nF NPO ±10% 0805	L0673102ANGA0
C38	CAP 1nF NPO ±10% 0805	L0673102ANGA0
C39	CAP 10nF X7R ±10% 0805	L0673103AXGA0
C41	CAP 10nF X7R ±10% 0805	L0673103AXGA0
C43	CAP 1nF NPO ±10% 0805	L0673102ANGA0
C45	CAP 10nF X7R ±10% 0805	L0673103AXGA0
C46	CAP 12pF NPO ±5% 0805	L06731205NGA0
C47	CAP 1nF NPO ±10% 0805	L0673102ANGA0
C48	CAP 1nF NPO ±10% 0805	L0673102ANGA0
C50	CAP 10pF NPO ±5% 0805	L06731005NGA0
C51	CAP 330pF NPO ±5% 0805	L06733315NGA0
C52	CAP 330pF NPO ±5% 0805	L06733315NGA0



C53	CAP 330pF NPO ±5% 0805	L06733315NGA0
C54	CAP 330pF NPO ±5% 0805	L06733315NGA0
C55	CAP 330pF NPO ±5% 0805	L06733315NGA0
C56	CAP 330pF NPO ±5% 0805	L06733315NGA0
C57	CAP 330pF NPO ±5% 0805	L06733315NGA0
C58	CAP 330pF NPO ±5% 0805	L06733315NGA0
C59	CAP 330pF NPO ±5% 0805	L06733315NGA0
C60	CAP 330pF NPO ±5% 0805	L06733315NGA0
C61	CAP 330pF NPO ±5% 0805	L06733315NGA0
D1	BZX84C5V6 [SOT 23]	L063SC5V6XXA0
D2	BAS16 [SOT 23]	L063SBAS16XA0
D3	BAS16 [SOT 23]	L063SBAS16XA0
D4	BZX84C10 [SOT-23]	L063SCV10XXA0
D5	BAR18 SOT 23	L063SBAR18XA0
D6	BAR18 SOT 23	L063SBAR18XA0
D7	BAR18 SOT 23	L063SBAR18XA0
FL1	EMI SUPPRESSION FILTER	L066DSS102XA0
H1	HEATSINK FOR T039	L004TV76XXXA0
IC1	M67712-E02 RF POWER AMP	L057M67712XA0
IC2	LM317T [TO220]	L057LM317TXA0
IC3	BA15532F [S0-8]	L057S5532XXA0
J1	AVDEL AVSERT M2.5 X 9mm	L0131176590A0
L1	IND 39nH 5% [1008]	L06483935CXA0
L2	12.5nH SM AIR CORE IND	L0649123ASXA0
L3	IND 39nH AIR CORED	L06493935AXA0
L4	IND 44nH AIR CORED	L06494435AXA0
L5	IND 39nH AIR CORED	L06493935AXA0
L6	IND 39nH 5% [1008]	L06483935CXA0
L7	IND 39nH 5% [1008]	L06483935CXA0
L8	IND 39nH 5% [1008]	L06483935CXA0
PCB1	PA PCB	L001PAB3SB3C0
PL1	50_ SUB MIN COAX CON SM	L013OSMTPCBA0
PL2	50_ SUB MIN COAX CON SM	L013OSMTPCBA0
PL3	50_ SUB MIN COAX CON SM	L013OSMTPCBA0
PL4	4 X 1 LATCHED PIN HEADER	L0134X12MMPA0
PL5	4 X 1 LATCHED PIN HEADER	L0134X12MMPA0
R1	RES 1K 0.1W ±2% 0805	L07131022P0A0
R2	RES 470R 0.1W ±2% 0805	L07134712P0A0
R3	RES 18R 0.125W ±2% 1206	L07141802P8A0
R4	RES 22R 0.125W ±2% 1206	L07142202P8A0
R5	RES 2K2 0.1W ±2% 0805	L07132222P0A0
R6	RES 1K 0.1W ±2% 0805	L07131022P0A0
R7	RES 12K 0.1W ±2% 0805	L07131232P0A0
R8	RES 1K 0.1W ±2% 0805	L07131022P0A0
R9	RES 1K 0.1W ±2% 0805	L07131022P0A0
R10	RES 10K 0.1W ±2% 0805	L07131032P0A0
R11	RES 10K 0.1W ±2% 0805	L07131032P0A0
R12	RES 10K 0.1W ±2% 0805	L07131032P0A0
R13	RES 10K 0.1W ±2% 0805	L07131032P0A0
R14	RES 10K 0.1W ±2% 0805	L07131032P0A0
R15	RES 3K3 0.1W ±2% 0805	L07133322P0A0
R16	RES 33K 0.1W ±2% 0805	L07133332P0A0
R17	RES 1X5 0.1W ±2% 0805	L07131522P0A0
R18	RES 240R 0.1W ±2% 0805	L07132412P0A0
R19	RES 100R 0.1W ±2% 0805	L07131012P0A0
R20	RES 10K 0.1W ±2% 0805	L07131032P0A0
R21	RES 51R 0.1W ±2% 0805	L07135102P0A0
R22	RES 10K 0.1W ±2% 0805	L07131032P0A0
R23	RES 56K 0.1W ±2% 0805	L07135632P0A0
R24	RES 180K 0.1W ±2% 0805	L07131842P0A0
R25	RES 10K 0.1W ±2% 0805	L07131032P0A0
R26	RES 10K 0.1W ±2% 0805	L07131032P0A0
R27	RES 56K 0.1W ±2% 0805	L07135632P0A0



R28	RES 180K 0.1W ±2% 0805	L07131842P0A0
R29	RES 51R 0.1W ±2% 0805	L07135102P0A0
R30	RES 10K 0.125W ±2% 1206	L07141032P8A0
R31	RES 4K7 0.1W ±2% 0805	L07134722P0A0
R32	RES 10K 0.1W ±2% 0805	L07131032P0A0
R33	RES 10K 0.1W ±2% 0805	L07131032P0A0
RL1	TQ2-9, RL501	L051TQ2-9XXA0
S1	AVDEL RIVSCREW M3.5 X 5	L0131712350A0
S2	M3 PLASTIC NUT	L029M3PLASNA0
S3	M3 PLASTIC NUT	L029M3PLASNA0
S4	M3 X 10mm PLASTIC SCREW	L029M3X10MPA0
S5	M3 X 10mm PLASTIC SCREW	L029M3X10MPA0
TH1	PTC THERMISTOR 80DEG	L069PTH9BF2A0
TR1	BC846A [SOT-23]	L060SBC846AA0
TR2	BC856A [SOT-23]	L060SBC856AA0
TR3	2N3866 [TO-39]	L0602N3866XA0
TR4	BC846A [SOT-23]	L060SBC846AA0
TR5	BC846A [SOT-23]	L060SBC846AA0
TR6	RFD15P05SM TO252AA/DPAK	L060RFD15PXA0



USA 220 Power Amplifier 25W Filter

PCB Parts List

Document No: LM030400016

Issue 1.3

Reference	Description	Stock Number
CPA1	100pF EMI SUPP FILTER	L066DSS101XA0
CPA2	100pF EMI SUPP FILTER	L066DSS101XA0
CPA3	EMI SUPPRESSION FILTER	L066DSS102XA0
CPA4	EMI SUPPRESSION FILTER	L066DSS102XA0
CPA5	EMI SUPPRESSION FILTER	L066DSS102XA0
CPA6	EMI SUPPRESSION FILTER	L066DSS102XA0
CPA7	EMI SUPPRESSION FILTER	L066DSS102XA0
CPA8	EMI SUPPRESSION FILTER	L066DSS102XA0
CPA9	EMI SUPPRESSION FILTER	L066DSS102XA0
D1	DIODE 1N4001	L063C1N4001A0
J1	AVDEL AVSERT M2.5 X 9mm	L0131176590A0
J2	AVDEL AVSERT M2.5 X 9mm	L0131176590A0
PA4	5X2 PIN HEADER	L01305X2TSXA0
PCB	25W BASE PA FILTER PCB	L001BPAFPCEBA0
PL4	4 X 1 LATCHED PIN HEADER	L0134X12MMPA0
PL5	4 X 1 LATCHED PIN HEADER	L0134X12MMPA0
R1	RES 2K7 0.5W 2% AXIAL	L069X2722MAA0
R2	RES 2K7 0.5W 2% AXIAL	L069X2722MAA0
R3	RES 1K0 0.5W 2% AXIAL	L069X1022MAA0
R4	RES 220R 0.5W 2% AXIAL	L069X2212MAA0
R5	RES 1K0 0.5W 2% AXIAL	L069X1022MAA0
R6	RES 10R 1.0W 5% AXIAL	L069X1005MAA0
R7	RES 56R 2.0W 5% AXIAL	L069X560BWBA0
TR1	TRANSISTOR BC546 TO92	L060TBC546XA0
TR2	TRANSISTOR BC327 TO92	L060TBC327XA0



Power Amplifier 25W

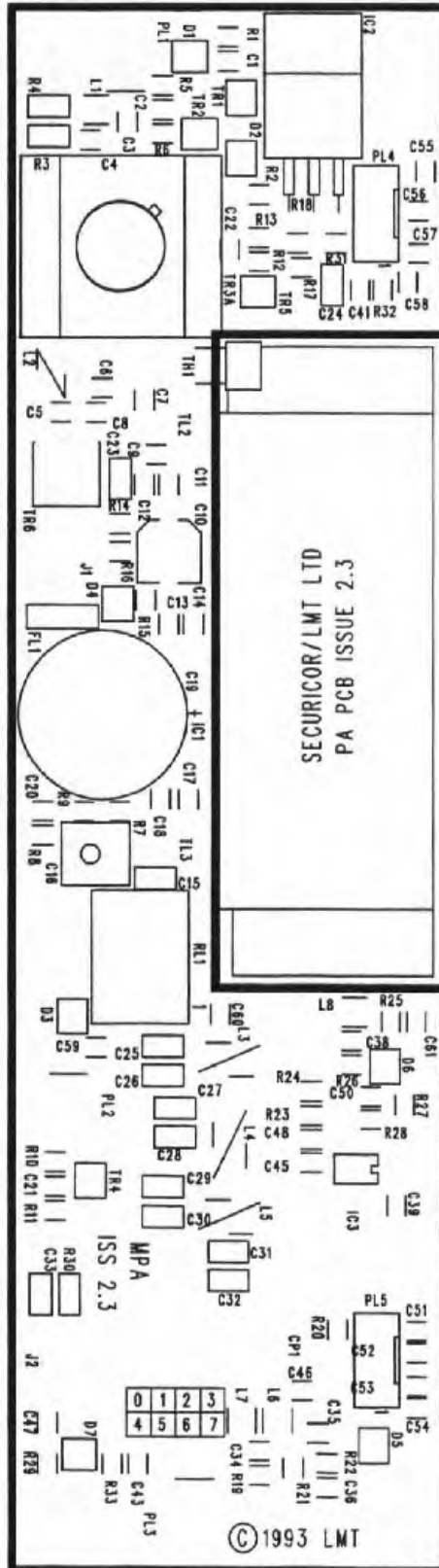



Power Amplifier 25W Filter

LM LTD 25W BRSE STATION ISSUE 2
COMPONENT SIDE .1

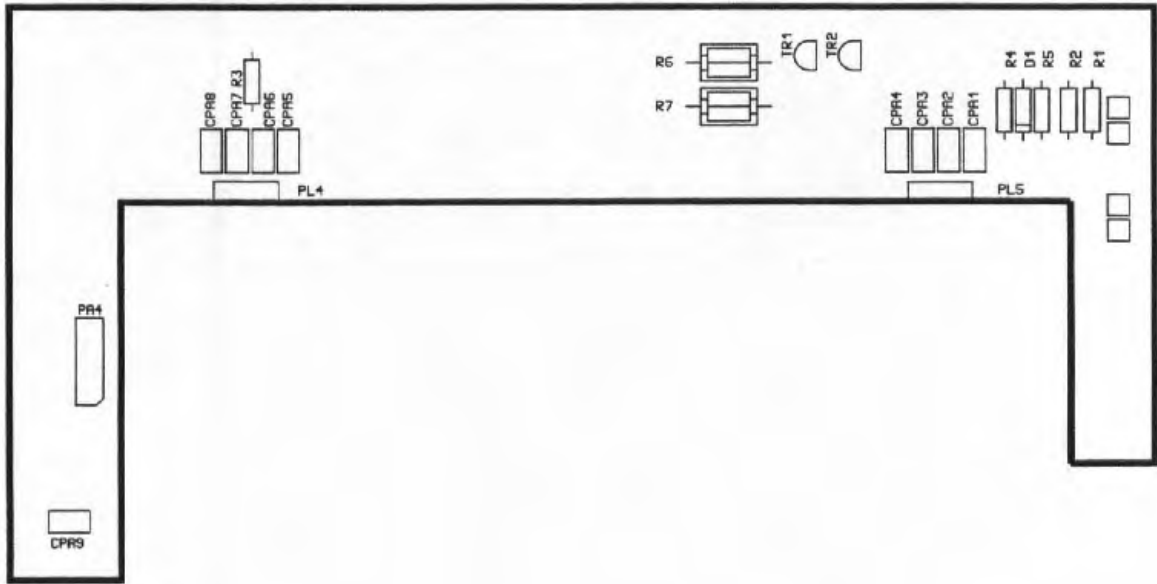

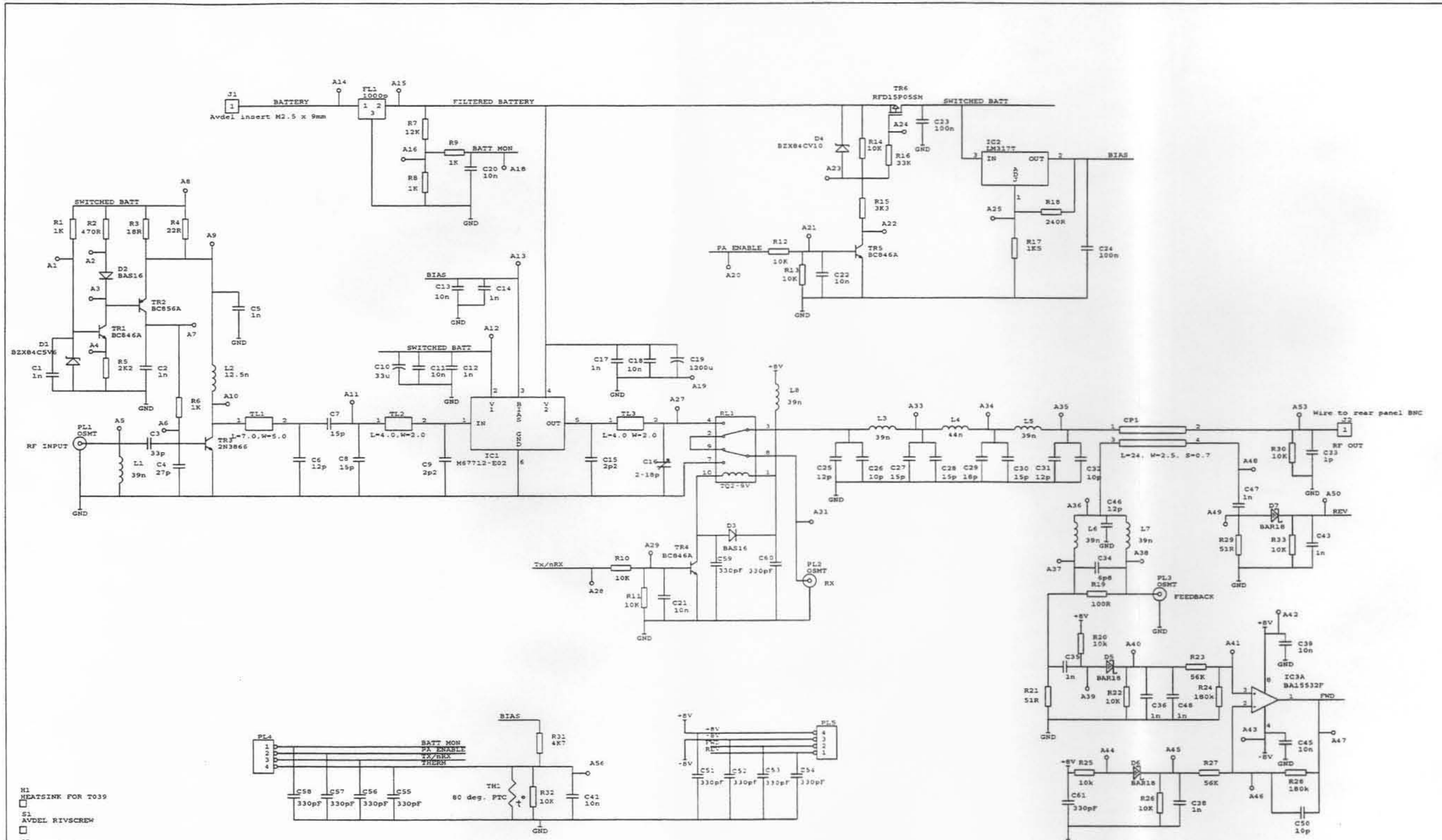

- M1 HEATSINK FOR T039
- S1 AVDEL RIVSCREW
- S2 PLASTIC NUT
- S3 PLASTIC NUT
- S4 M3 x 10mm PLASTIC SCREW
- S5 M3 x 10mm PLASTIC SCREW
- PCB1 PA PCB

REV	DCF No.	DATE	CHK	Linear Modulation Technology Ltd. Cross Keys House Westfield Industrial Estate Widower Norton Bath, BA1 4NS	1995 Copyright LMT Ltd
2.4	L171	23/5/95		POWER AMPLIFIER 25W USA 220MHz 25W PA	
		June 6, 1995	SCALE	DWG NO LM040401007	REV 2.4
				SHEET	1 OF 3



18. Power Amplifier 100 W

Contents

General Assemblies	18-3
Chassis.....	18-3
Module Parts List	18-7
Looms	18-9
RF FDBK Loom 100Wp/a.....	L033PALPA9IA0 18-9
Red LED Loom.....	L033PALPA6IA0 18-10
Green LED Loom.....	L033PALPA7IA0 18-11
PA Drv Loom 100Wp/a.....	L033PALPA10B0..... 18-12
100W TX Out Loom.....	L033PALPA11B0..... 18-13
100W DC Power Loom.....	L033PALPA12B0..... 18-14
100W P/A Inductor L5.....	L033PAINDL5B0 18-15
100W P/A Inductor L6.....	L033PAINDL6A1 18-16
100W P/A Inductor L7.....	L033PAINDL7A0 18-17
Transformer A.....	L033PATRANAA1 18-18
Transformer B.....	L033PATRANBB1 18-19
Transformer C.....	L033PATRANCA0 18-20
Transformer D.....	L033PATRANDA0 18-21
Transformer E.....	L033PATRANEA1 18-22
Siemens B62152A1X1 C.....	L033PAINDL3A0 18-23
100W P/A Output Stub.....	L033PAINDL8B0 18-24
9t 1mm Wire 4mm ID.....	L033PAINDL4A0 18-25
PCB Parts List	18-26
Overlays	18-29
Circuit Diagrams	18-31
PA 100 W.....	18-31

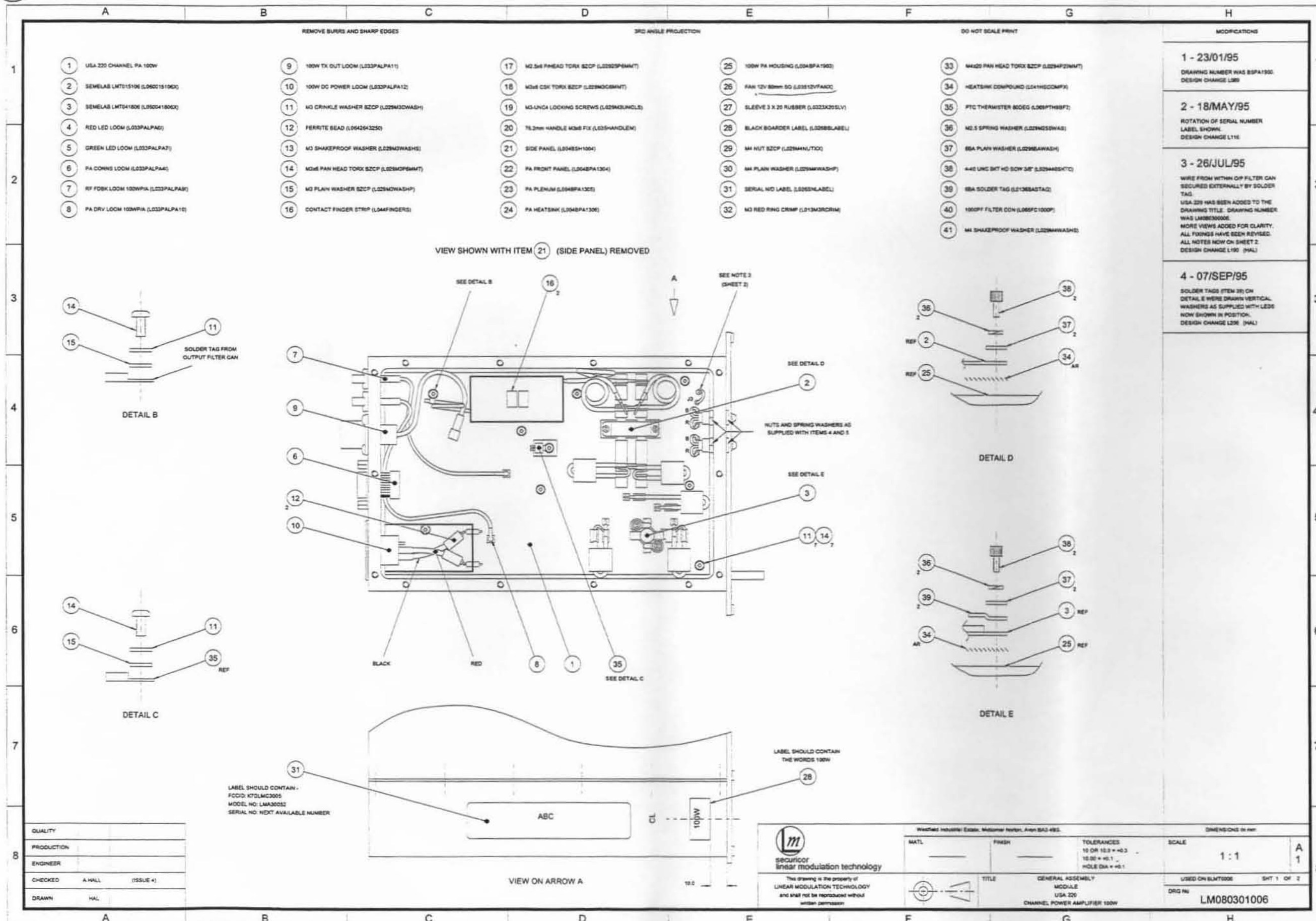

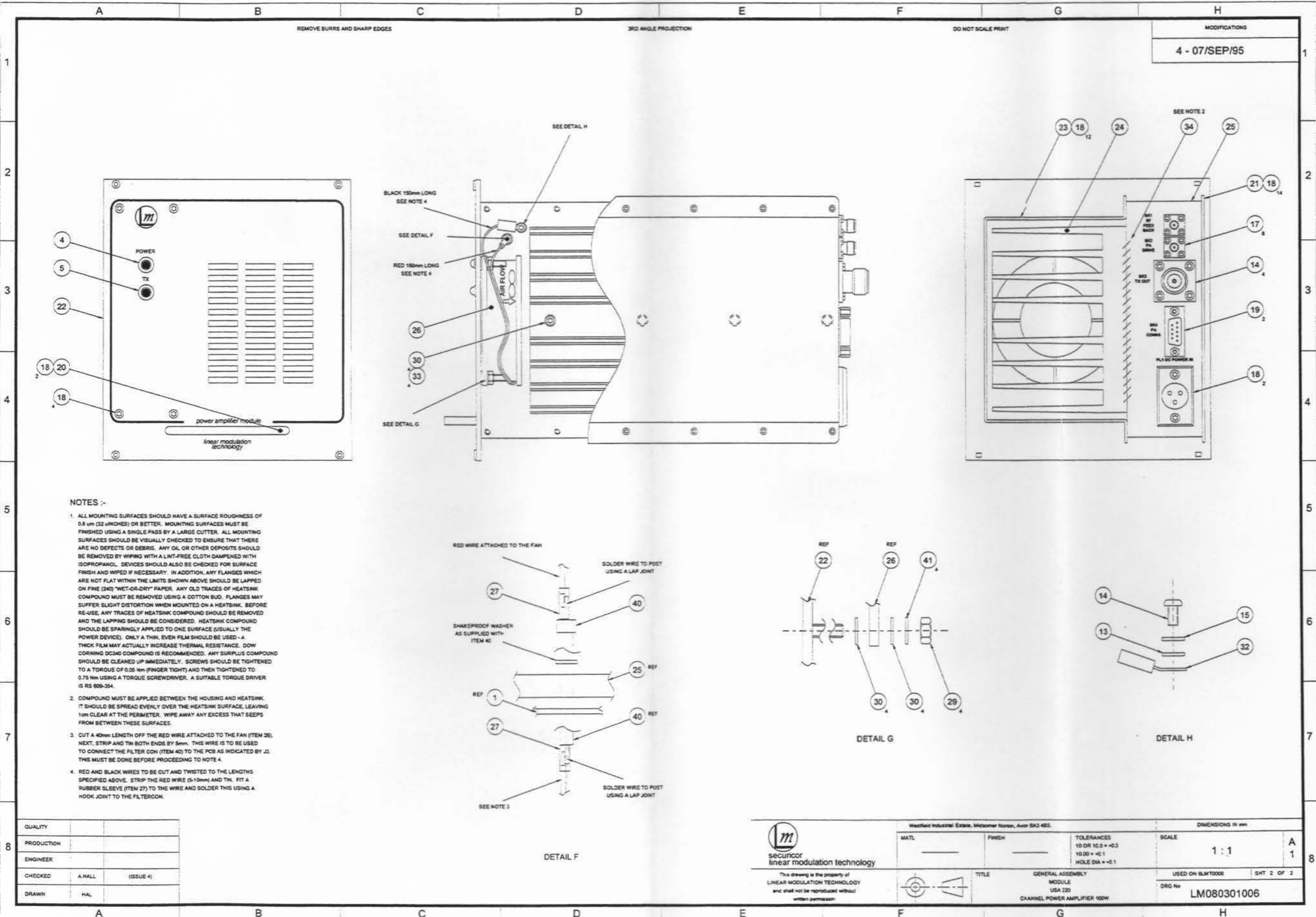



Module Parts List

USA 220 Channel Power Amplifier 100W

Document No: LM030301006

Issue 1.1

Quantity	Description	Stock Number
1	PA FRONT PANEL	L004BPA1304B0
1	PA PLENUM	L004BPA1305A0
1	PA HEATSINK	L004BPA1306B1
1	100W P.A. HOUSING	L004BPA1903A3
1	SIDE PANEL	L004BSH1004A0
2	6BA SOLDER TAG	L0136BASTAGA0
1	M3 RED RING CRIMP	L013M3RCRIMA0
1	BLACK BORDER LABEL	L026BBLABELA0
1	SERIAL N/D LABEL	L026SNLABELB0
8	M2.5X6 P/HEAD TORX BZCP	L02925P6MMTA0
4	4-40 UNC SKT HD SCW 3/8"	L029440SKTCA0
4	M4X20 PAN HEAD TORX BZCP	L0294P20MMTA0
4	6BA PLAIN WASHER	L0296BAWASHA0
4	M2.5 SPRING WASHER	L029M25SWASA0
34	M3X6 CSK TORX BZCP	L029M3C6MMTA0
9	M3 CRINKLE WASHER	L029M3CWASHA0
14	M3X6 PAN HEAD TORX BZCP	L029M3P6MMTA0
2	M3-UNC4 LOCKING SCREWS	L029M3UNCLSA0
3	M3 PLAIN WASHER BZCP	L029M3WASHPA0
1	M3 SHAKEPROOF WASHER	L029M3WASHSA0
4	M4 NUT BZCP	L029M4NUTXXA0
12	M4 PLAIN WASHER	L029M4WASHPA0
4	M4 SHAKEPROOF WASHER	L029M4WASHSA0
1	SLEEVE 3 x 20 RUBBER	L0323X20SLVA0
1	PA DRV LOOM 100Wp/a	L033PALPA10B0
1	100W TX OUT LOOM	L033PALPA11B0
1	100W DC POWER LOOM	L033PALPA12B0
1	PA CONNS LOOM	L033PALPA41B0
1	RED LED LOOM	L033PALPA61A0
1	GREEN LED LOOM	L033PALPA71A0
1	RF FDBK LOOM 100Wp/a	L033PALPA91B0
1	FAN 12V 80mm SQ	L03512VFANXA0
1	76.2mm HANDLE M3X8 FIX	L035HANDLEMA0
0.01	HEATSINK COMPOUND	L041HSCOMPXA0
2	CONTACT FINGER STRIP	L044FINGERSA0
1	SEMELAB LMT015106	L060015106XA0
1	SEMELAB LMT041806	L060041806XA0
2	FERRITE BEAD	L0642643250A0
1	1000PF FILTER CON	L066FC1000PA0
1	PTC THERMISTOR 80DEG	L069PTH9BF2A0

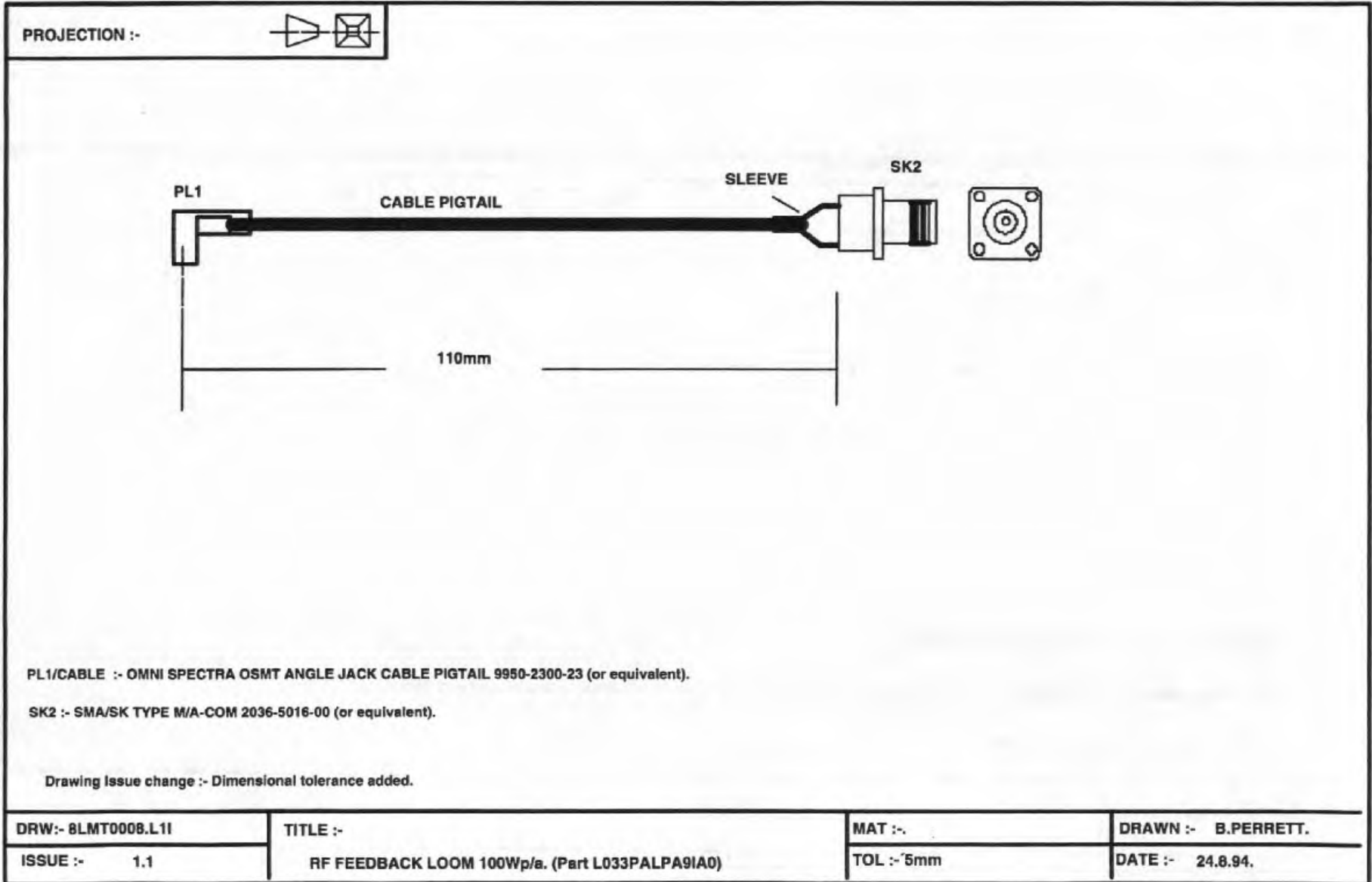



PROJECTION :-

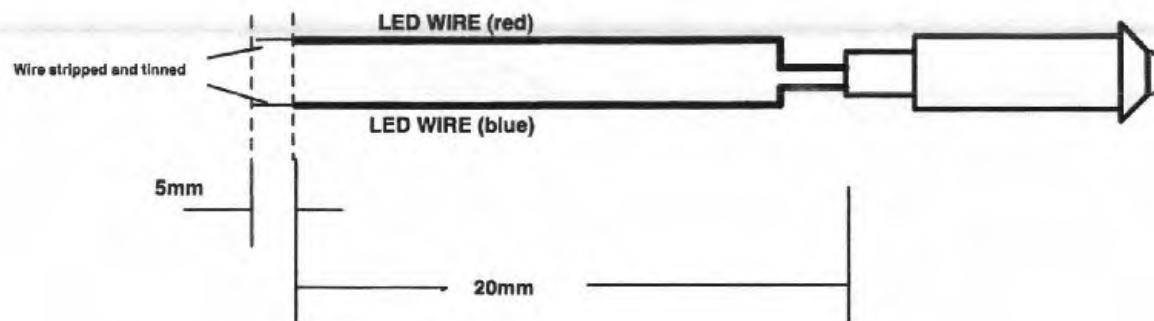
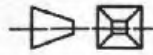

PANEL MOUNTING LED :- TYPE HERO SMRD 080-82.

NOTE :- LED is supplied with red and blue wires attached. Wires must be cut to specified length and stripped and tinned.

Previous drawing issue had ring terminals now deleted

DRW:- 8LMT0003.L6I	TITLE :- RED LED LOOM. (Part L033PALPA61)	MAT :-	DRAWN :- B.PERRETT.
ISSUE :- 1.1		FIN :-	DATE :- 18.4.94.

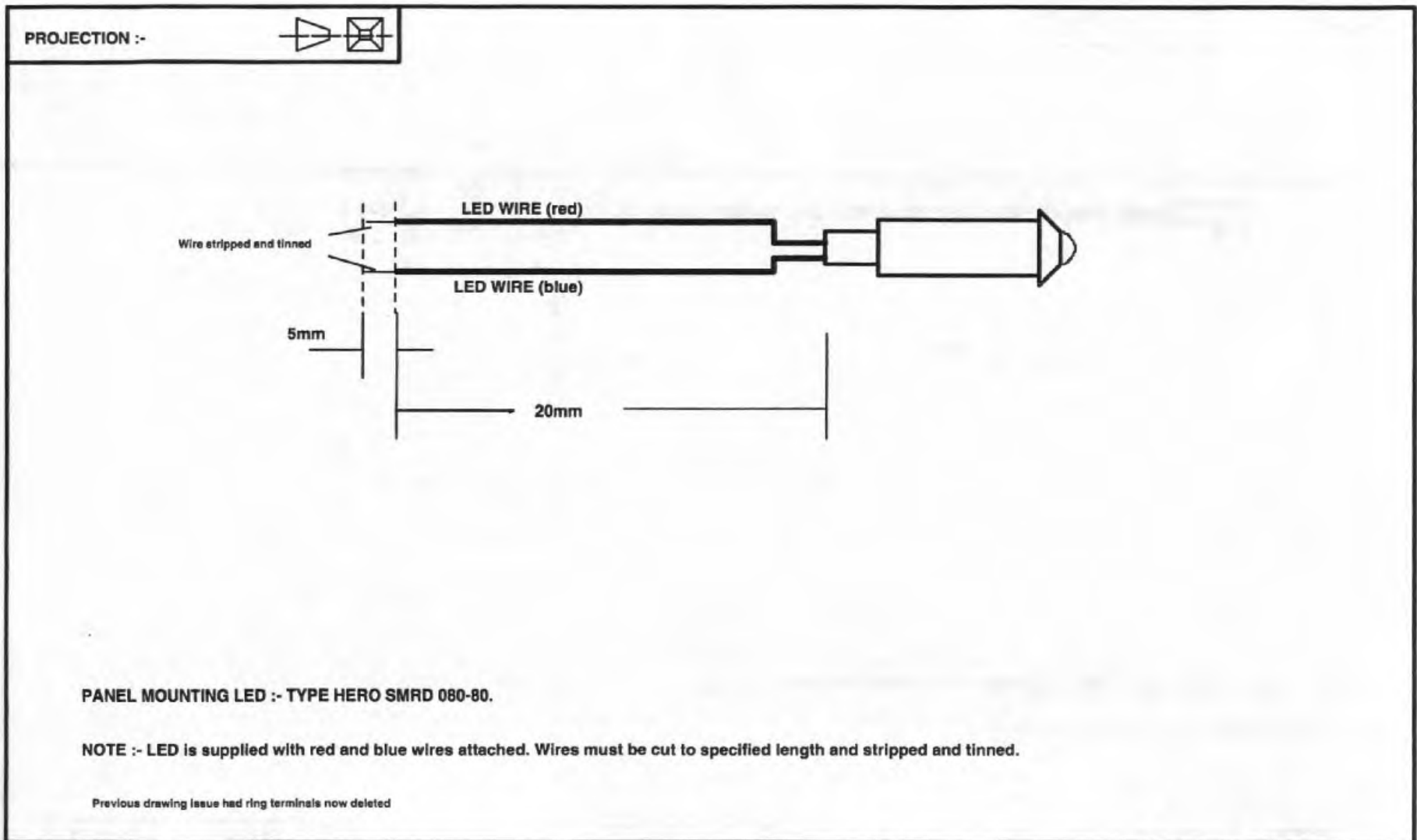

PANEL MOUNTING LED :- TYPE HERO SMRD 080-80.

NOTE :- LED is supplied with red and blue wires attached. Wires must be cut to specified length and stripped and tinned.

Previous drawing issue had ring terminals now deleted

DRW:- 8LMT0003.L7I	TITLE :- GREEN LED LOOM. (Part L033PALPA71)	MAT :-	DRAWN :- B.PERRETT.
ISSUE :- 1.1		FIN :-	DATE :- 18.4.94.



PROJECTION :-

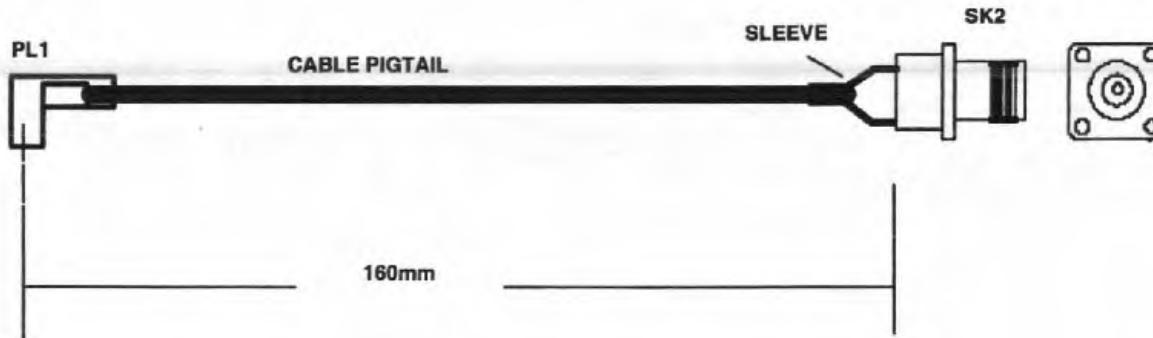
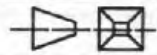

PL1/CABLE :- OMNI SPECTRA OSMT ANGLE JACK CABLE PIGTAIL 9950-2300-23 (or equivalent).

SK2 :- SMA/SK TYPE M/A-COM 2036-5016-00 (or equivalent).

Drawing Issue change :- Dimensional tolerance added.

DRW:- 8LMT0008.L2I	TITLE :-	MAT :-	DRAWN :- B.PERRETT.
ISSUE :- 1.1	PA DRIVE LOOM 100WP/A. (Part L033PALPA10A0)	TOL :- 5mm	DATE :- 24/8.94.

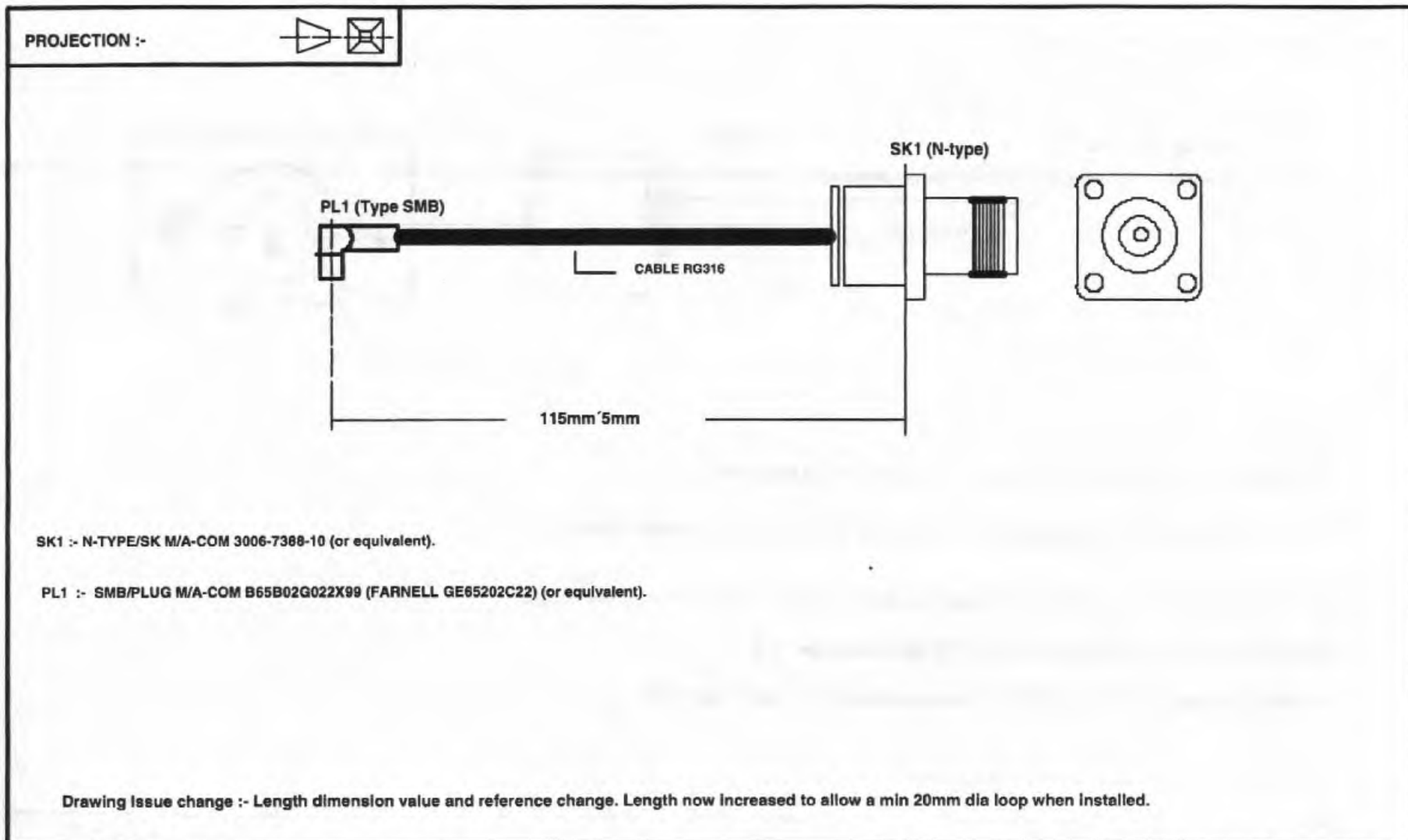

DRW:- 8LMT0008.L3I	TITLE :-	MAT :-	DRAWN :- B.PERRETT.
ISSUE :- 1.2	100W TX OUT LOOM. (Part L033PALPA11A0)	FIN :-	DATE :- 24.8.94.

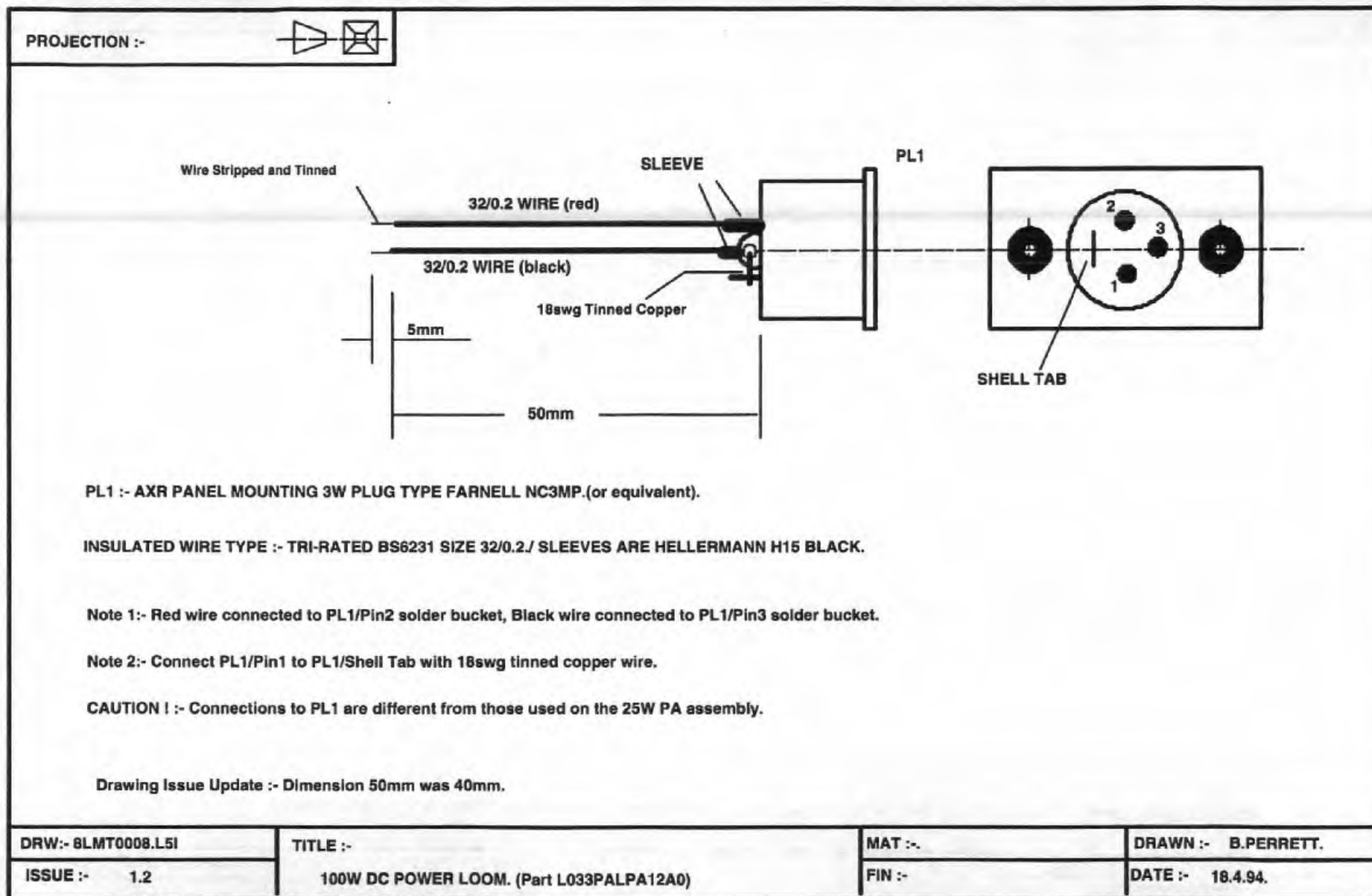

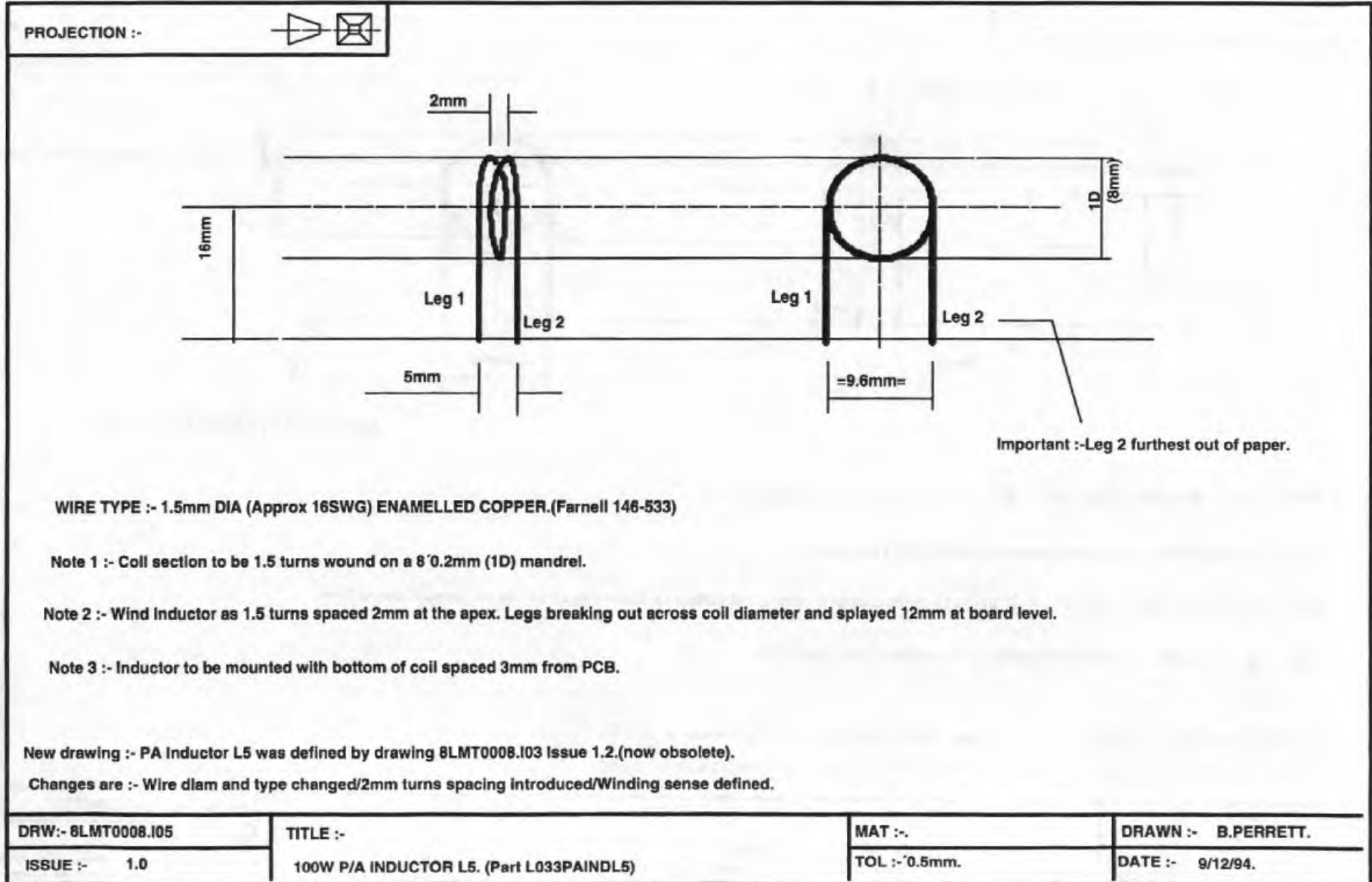



PROJECTION :-

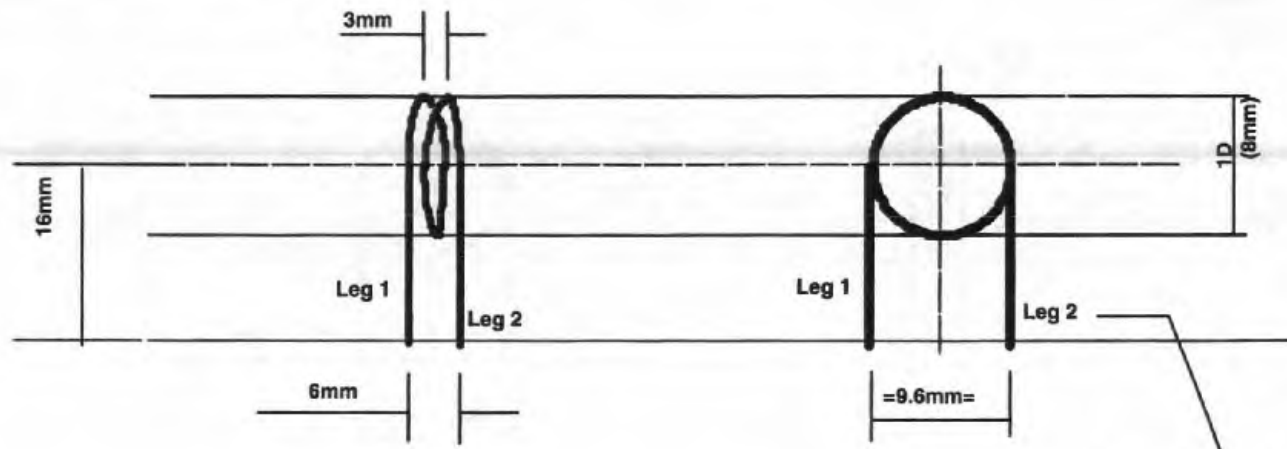
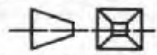

Important :- Leg 2 furthest out of paper.

WIRE TYPE :- 1.5mm DIA (Approx 16SWG) ENAMELLED COPPER.(Farnell 146-533)

Note 1 :- Coil section to be 1.5 turns wound on a 8.02mm (1D) mandrel.

Note 2 :- Wind Inductor as 1.5 turns spaced 3mm at the apex. Legs breaking out across coil diameter and splayed 12mm at board level.

Note 3 :- Inductor to be mounted with bottom of coil spaced 3mm from PCB.

New Drawing :- PA Inductor L6 was defined by drawing 8LMT0008.I03 Issue 1.2.(now obsolete).

Changes are :- Wire diam and type changed/3mm turns spacing introduced/Winding sense defined.

DRW:- 8LMT0008.I06	TITLE :-	MAT :-	DRAWN :- B.PERRETT.
ISSUE :- 1.0	100W P/A INDUCTOR L6. (Part L033PAINDL6)	TOL :- ±0.5mm.	DATE :- 9/12/94.

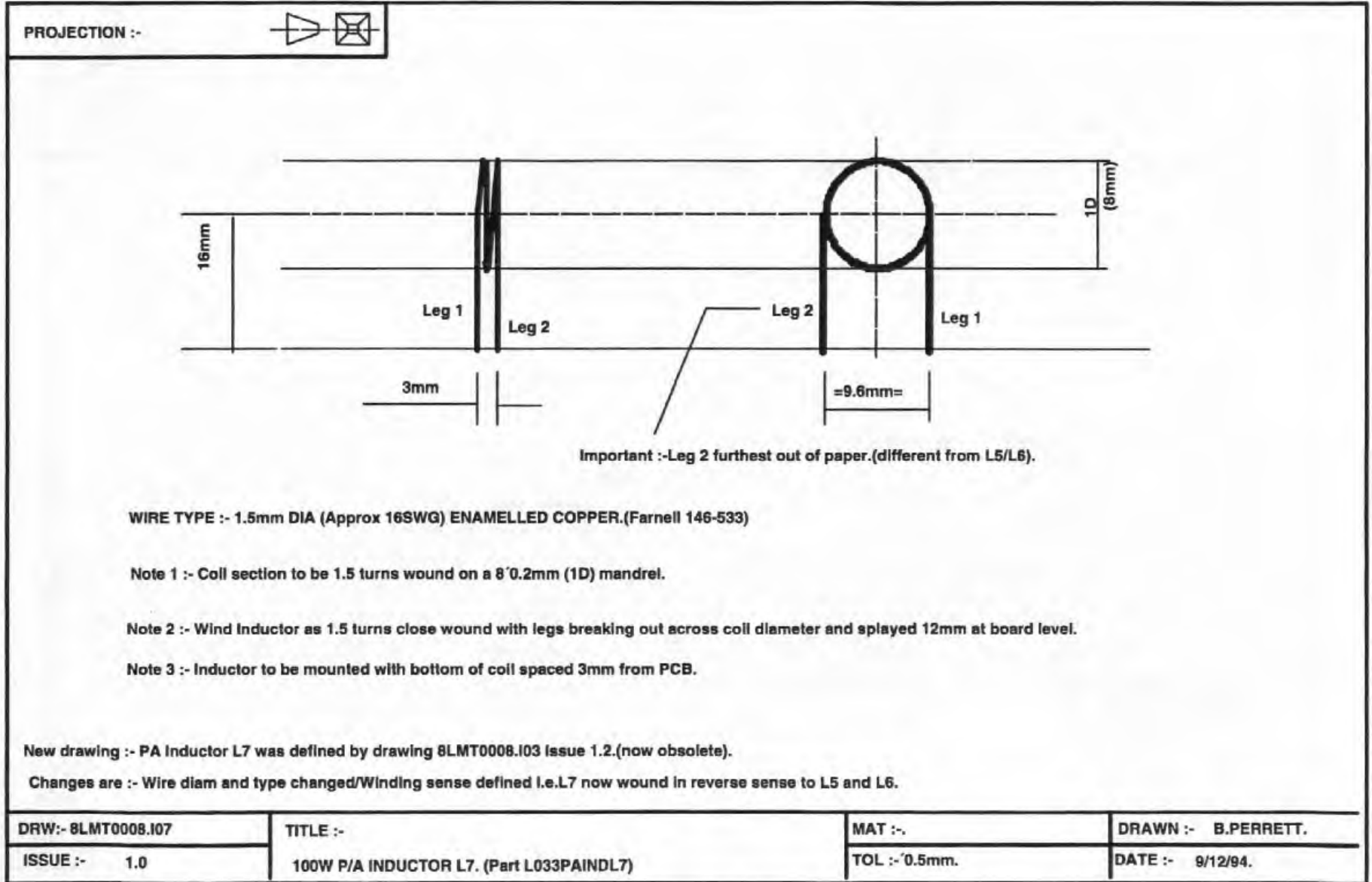

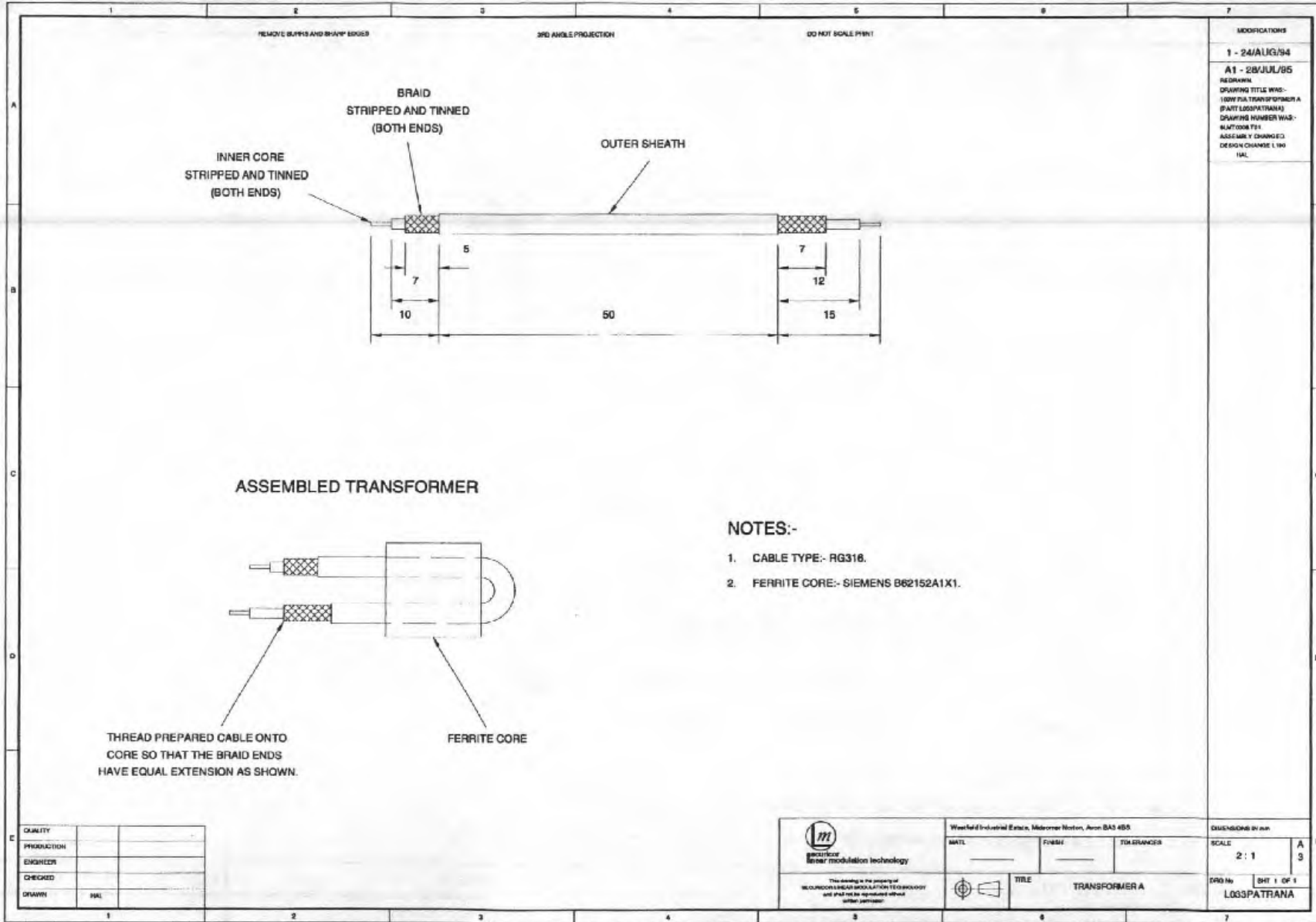

MODIFICATIONS
 1 - 24/AUG/94
 A1 - 28/JUL/85
 REDRAWN
 DRAWING TITLE WAS:
 100W PWA TRANSFORMER A
 (PART LOG3PATRANA)
 DRAWING NUMBER WAS:
 8447008724
 ASSEMBLY CHANGED:
 DESIGN CHANGE 1 190
 HAL

NOTES:-

1. CABLE TYPE:- RG316.
2. FERRITE CORE:- SIEMENS B62152A1 X1.

QUANTITY		
PRODUCTION		
ENGINEER		
CHECKED		
DRAWN	HAL	

<p>Westfield Industrial Estate, Malvern Motor, Acon BA3 4BS</p>	MATERIAL _____ FINISH _____ TOL CRANCES _____		DIMENSIONS IN mm
	SCALE 2 : 1		A 3
TITLE TRANSFORMER A	DRW No _____ SHY 1 OF 1		LOG3PATRANA

POWER AMPLIFIER 100 W

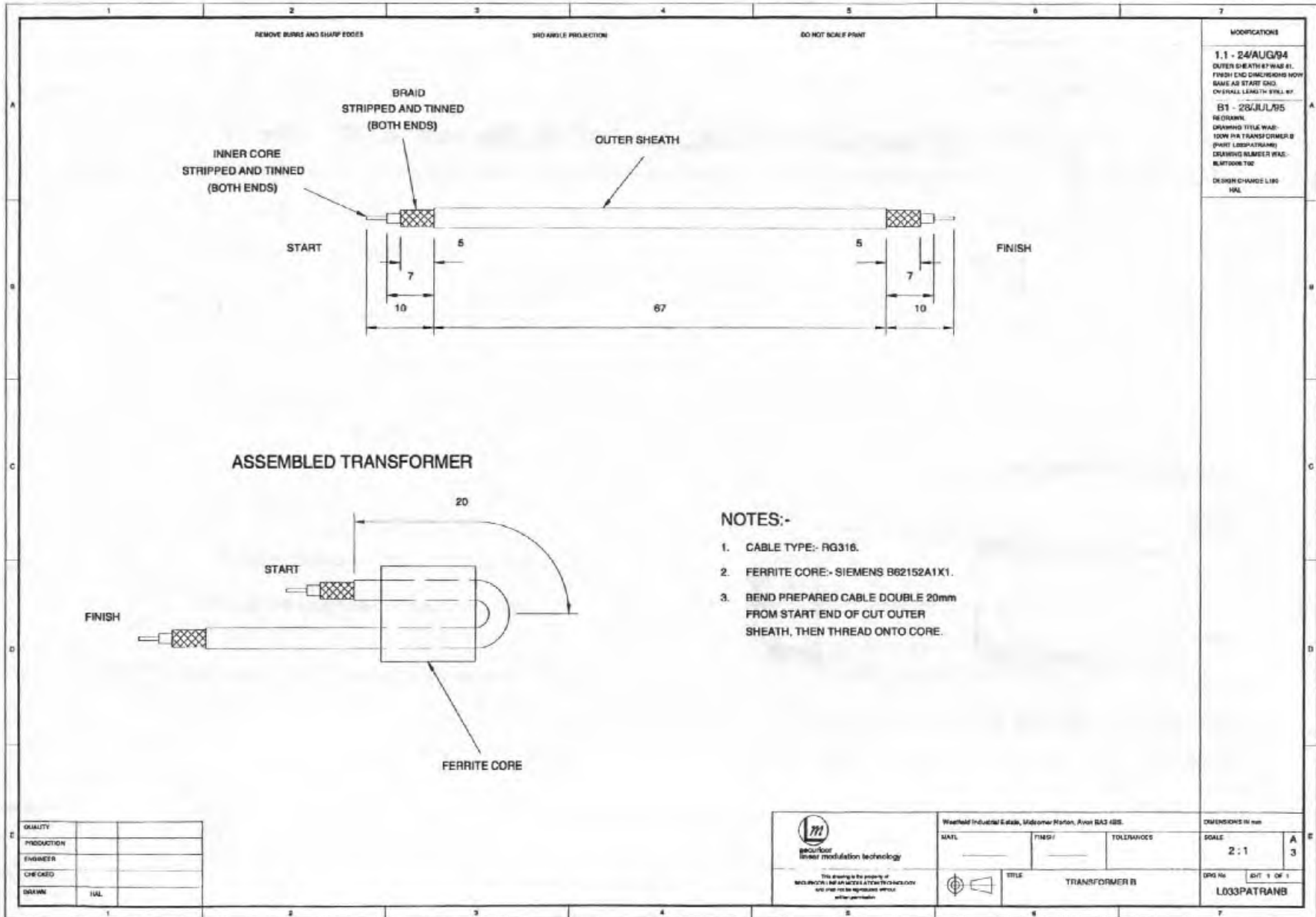



PROJECTION :-

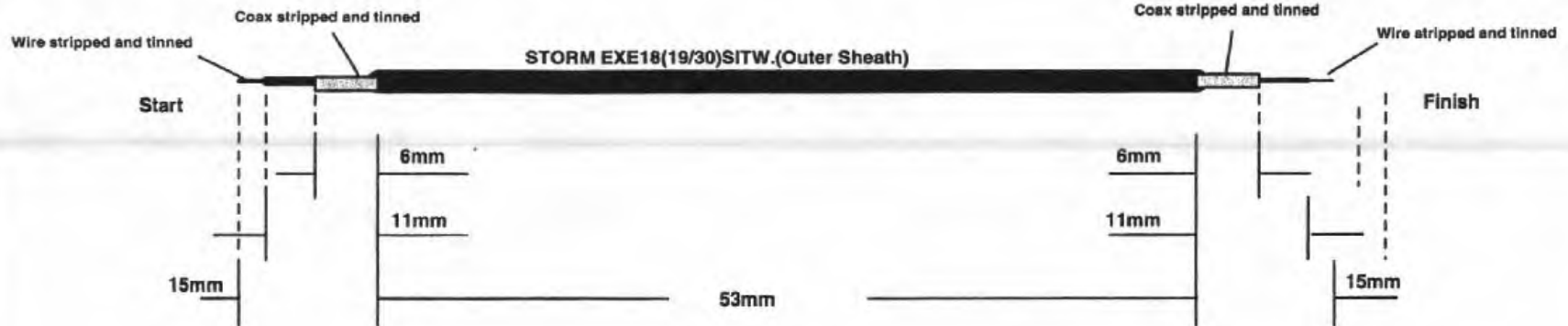
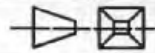

ASSEMBLED TRANSFORMER.

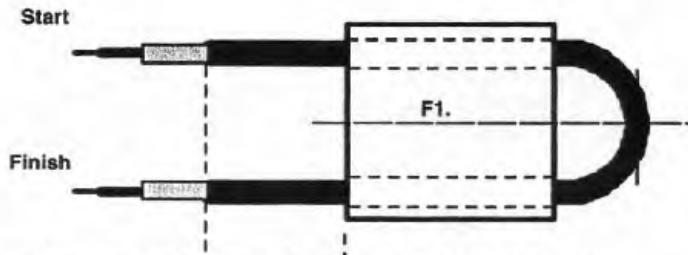

Bend prepared cable double at mid-point of cut outer sheath and thread onto core so that sheath ends have equal extension.

CABLE TYPE :- STORM EXE18(19/30)SITW.

FERRITE CORE F1 :-SIEMENS B62152A1X1.

Note :- Transformer C is used twice in assembly 8LMTT0008.

DRW:- 8LMT0008.T03

TITLE :-

MAT :-

DRAWN :- B.PERRETT.

ISSUE :- 1.0

100W P/A TRANSFORMER C. (Part L033PATRANC)

FIN :-

DATE :- 24.8.94.

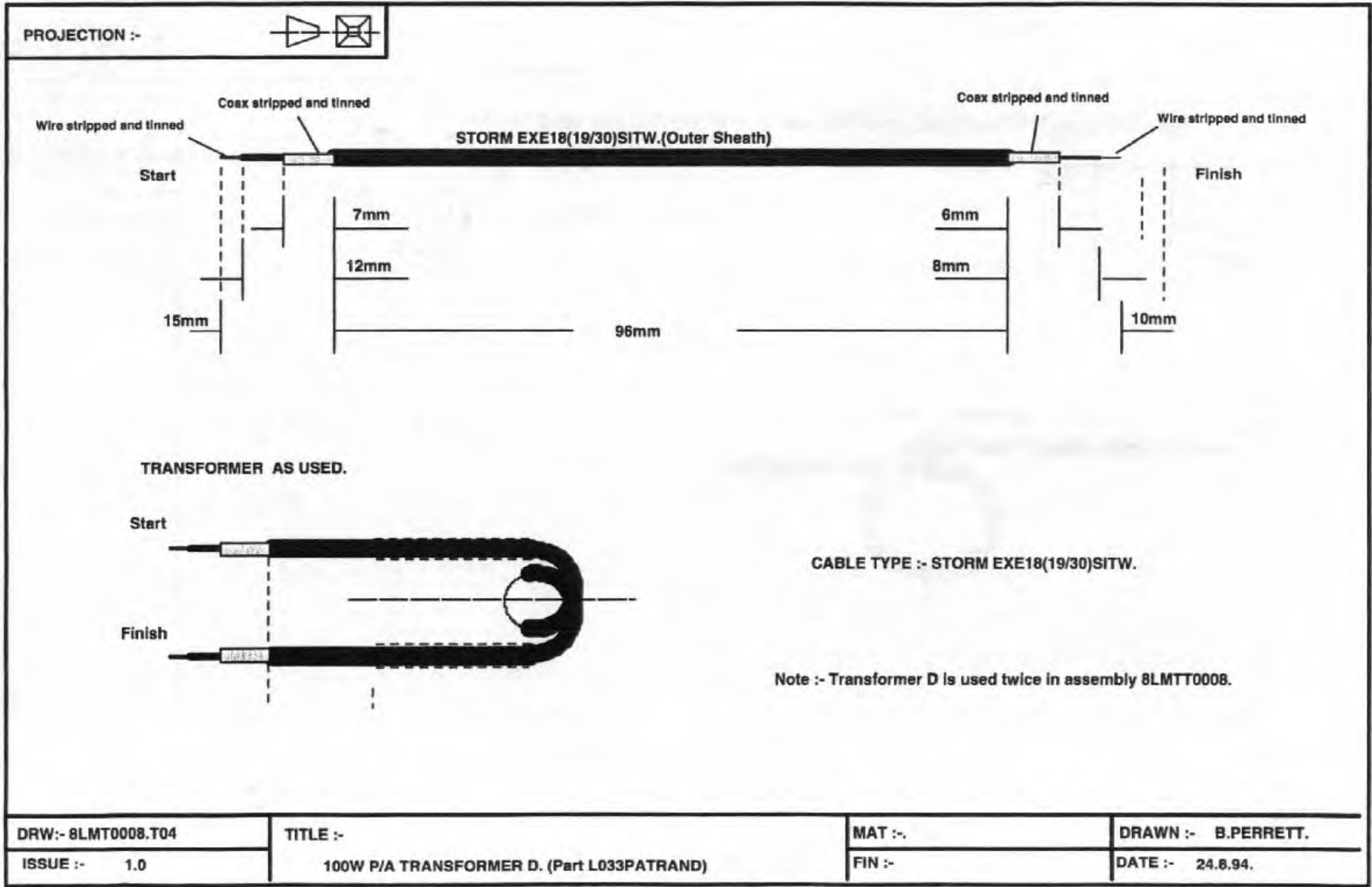

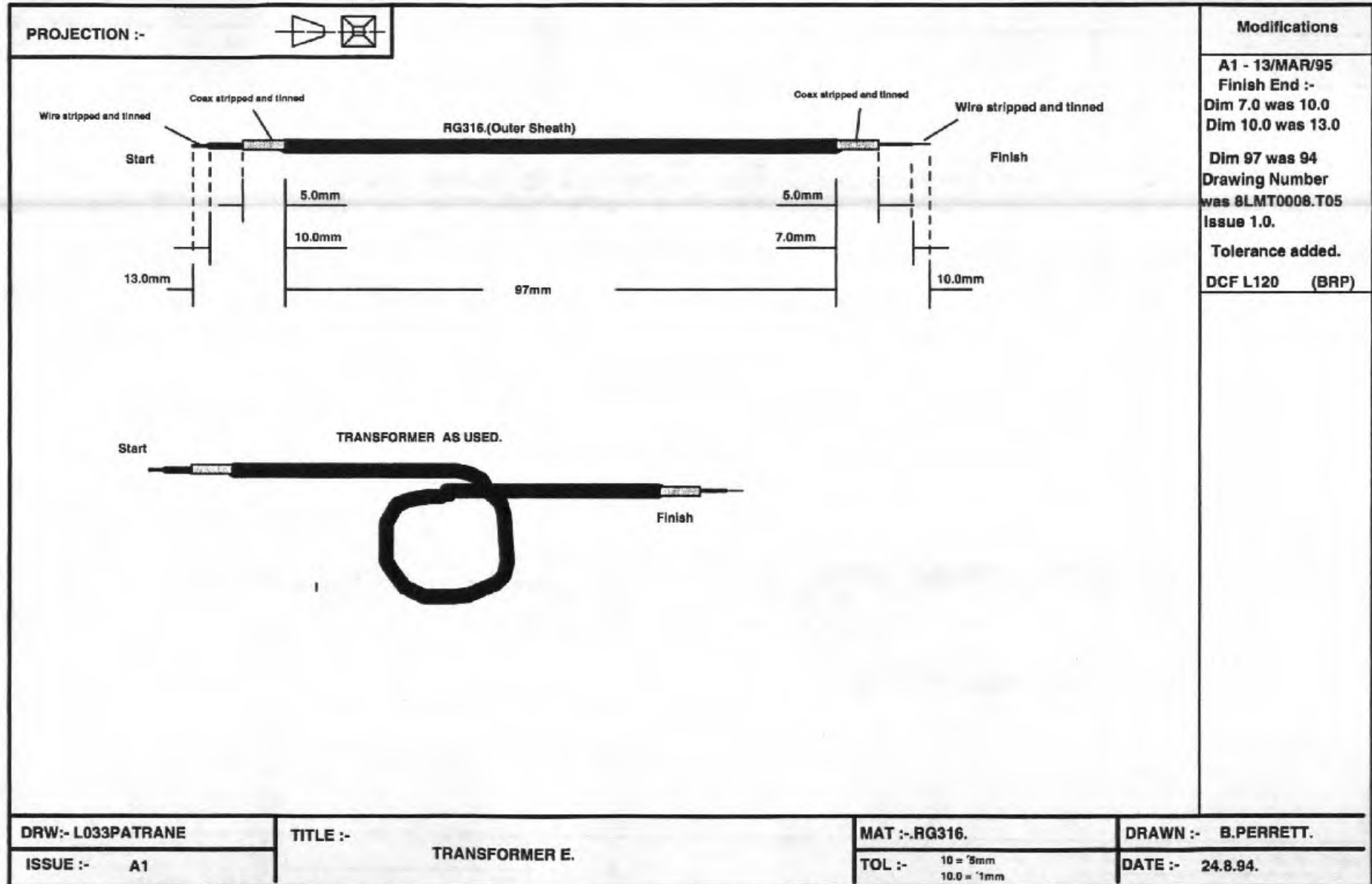

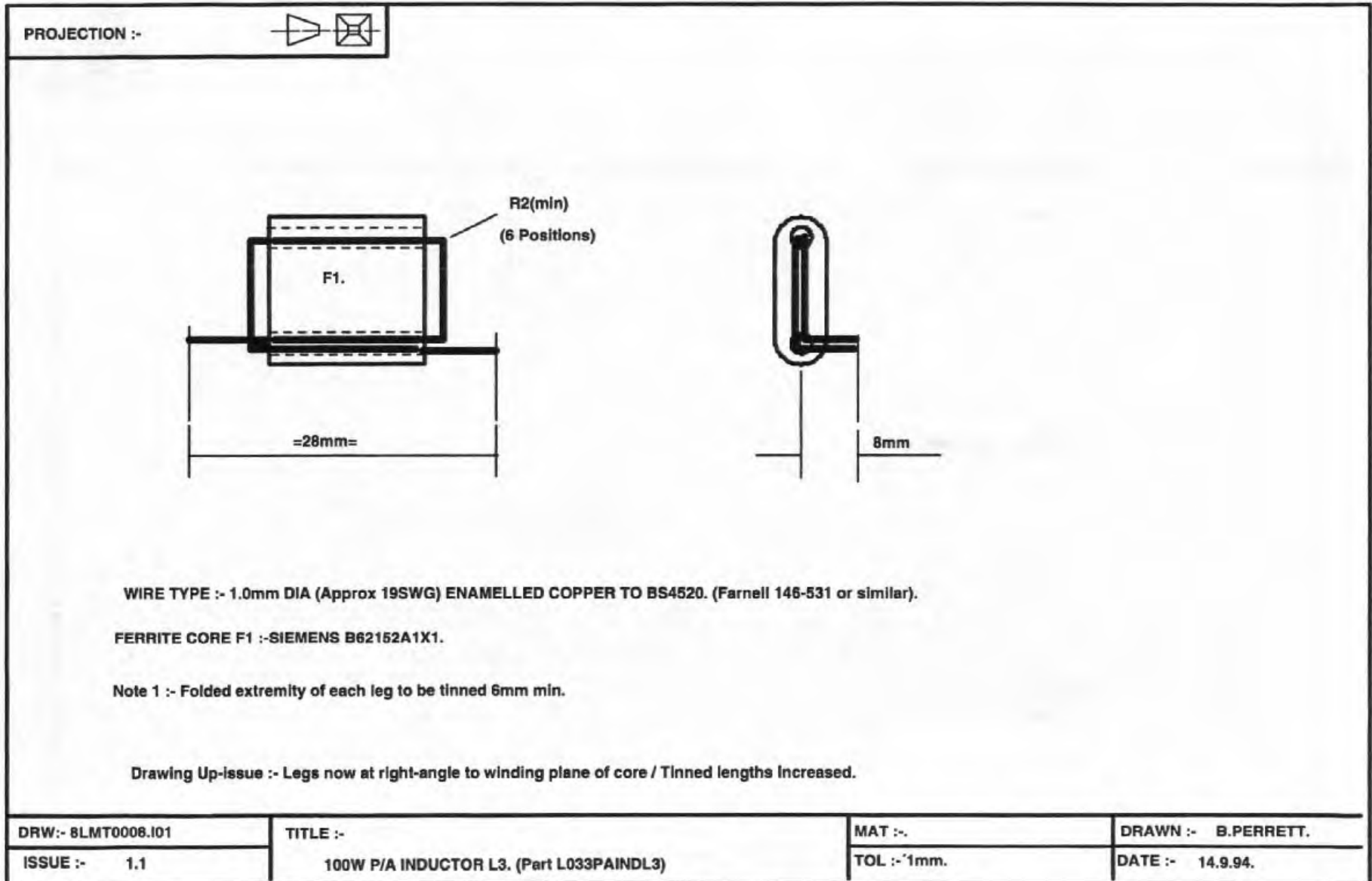

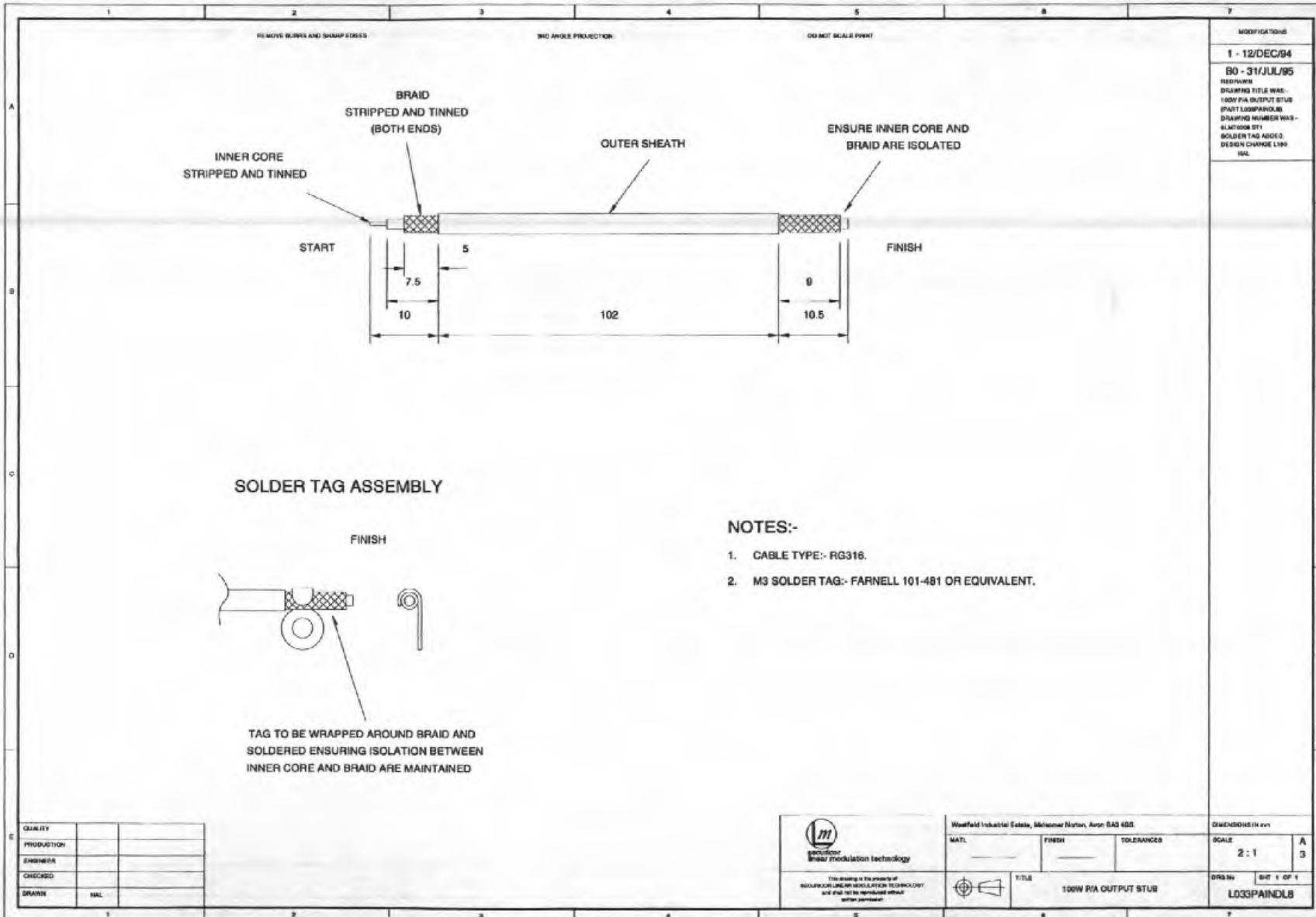



PROJECTION :-

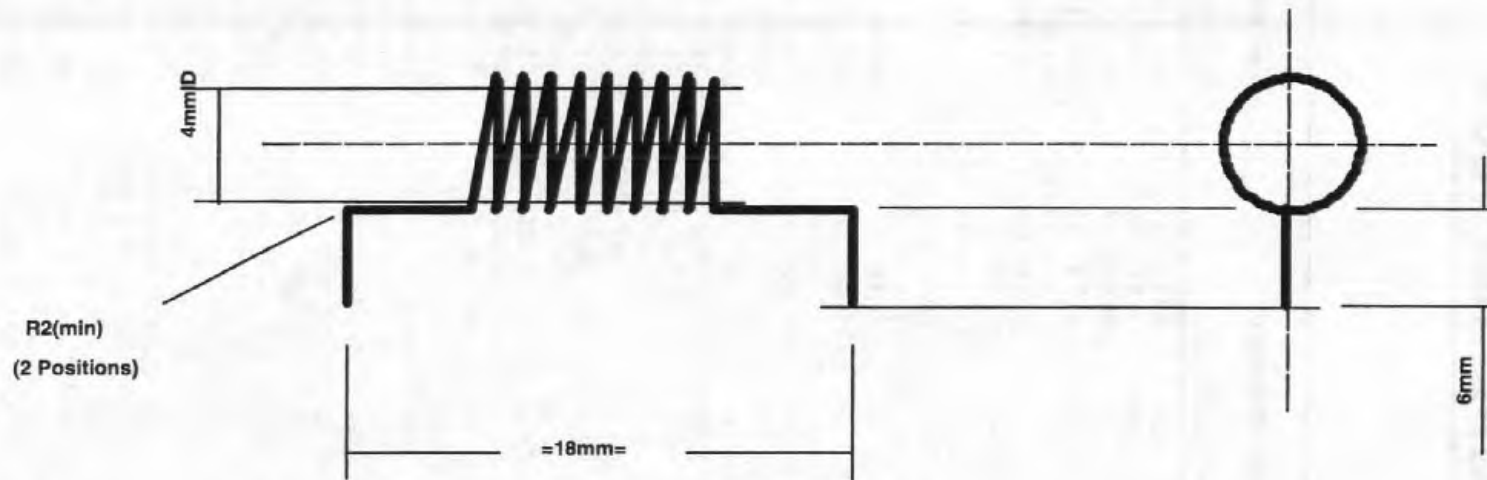
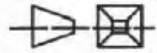

WIRE TYPE :- 1.0mm DIA (Approx 19SWG) ENAMELLED COPPER TO BS4520. (Farnell 146-531 or similar).

Note 1 :- Coil section to be 9 full turns close wound on a 4mm mandrel.

Note 2 :- Each leg to be tinned 5mm min.

Drawing Up-issue :- Tinning of legs increased to 5mm min.

DRW:- 8LMT0008.I02

TITLE :-

MAT :-

DRAWN :- B.PERRETT.

ISSUE :- 1.1

100W P/A INDUCTOR L4. (Part L033PAINDL4)

TOL :- ±1mm.

DATE :- 14.9.94.



USA 220 Power Amplifier 100W

PCB Parts List

Document No: LM030401017		Issue 2.2
Reference	Description	Stock Number
C1	CAP 10pF NPO ±5% 0805	L06731005NGA0
C2	CAP 100pF NPO ±5% 0805	L06731015NGA0
C3	1n SM NPO 1206 50V 5%	L06741025NGA0
C4	1n SM NPO 1206 50V 5%	L06741025NGA0
C5	CAP 100nF X7R ±10% 1206	L0674104AXGA0
C6	1n SM NPO 1206 50V 5%	L06741025NGA0
C7	1u SM TANT 35V 20%	L0679105BBZA0
C8	1n SM NPO 1206 50V 5%	L06741025NGA0
C9	33p SM NPO 1206 50V 5%	L06743305NGA0
C10	27p SM NPO 1206 50V 5%	L06742705NGA0
C11	1n SM NPO 1206 50V 5%	L06741025NGA0
C13	1n SM NPO 1206 50V 5%	L06741025NGA0
C14	CAP 33n X7R 10% 1206	L0674333AXGA0
C15	1n SM NPO 1206 50V 5%	L06741025NGA0
C16	1n SM NPO 1206 50V 5%	L06741025NGA0
C17	1n SM NPO 1206 50V 5%	L06741025NGA0
C18	CAP 100nF X7R ±10% 1206	L0674104AXGA0
C19	3p3 SM NPO 1206 50V 5%	L06743325NGA0
C20	33p SM NPO 1206 50V 5%	L06743305NGA0
C21	33p SM NPO 1206 50V 5%	L06743305NGA0
C22	47p SM ATC 500V 5%	L06794705ZXA0
C23	CAP 100nF X7R ±10% 1206	L0674104AXGA0
C24	CAP 560p 500V 10% HIGH Q	L06795615ZXA0
C25	CAP 560p 500V 10% HIGH Q	L06795615ZXA0
C26	1n SM NPO 1206 50V 5%	L06741025NGA0
C27	1n SM NPO 1206 50V 5%	L06741025NGA0
C28	CAP 100pF NPO ±5% 0805	L06731015NGA0
C29	CAP 10pF NPO ±5% 0805	L06731005NGA0
C30	CAP 10pF NPO ±5% 0805	L06731005NGA0
C31	1n SM NPO 1206 50V 5%	L06741025NGA0
C32	CAP 100pF NPO ±5% 0805	L06731015NGA0
C33	CAP 100nF X7R ±10% 1206	L0674104AXGA0
C34	1000u LEADED ELECT 40V	L0668108BEFA0
C35	CAP 15pF HIGH Q 500V 5%	L06791505ZXA0
C36	CAP 12pF HIGH Q 500V 5%	L06791205ZXA0
C37	CAP 15pF HIGH Q 500V 5%	L06791505ZXA0
C38	CAP 12pF HIGH Q 500V 5%	L06791205ZXA0
C39	1n SM NPO 1206 50V 5%	L06741025NGA0
C40	1n SM NPO 1206 50V 5%	L06741025NGA0
C41	CAP 15pF NPO ±5% 1206	L06741505NGA0
C42	6p8 SM NPO 1206 50V 5%	L06746825NGA0
C43	1n SM NPO 1206 50V 5%	L06741025NGA0
C44	1n SM NPO 1206 50V 5%	L06741025NGA0
C46	1n SM NPO 1206 50V 5%	L06741025NGA0
C47	1n SM NPO 1206 50V 5%	L06741025NGA0
C48	1n SM NPO 1206 50V 5%	L06741025NGA0



*D1 = 1A Rectifier
SMD
BZX84C5V6
[SOT 23]
75-46635C5V6XXA6
REF 25W
and EFJ 100W*

C49	CAP 10pF NPC ±5% 0805	L06731005NGAO
C51	1n SM NPO 1206 50V 5%	L06741025NGAO
C52	2p7 SM NPO 0805 50V 5%	L06732725NGAO
C53	CAP 10pF NPC ±5% 0805	L06731005NGAO
C54	0p68 SM NPO 0805 50V 5%	L067368Y5NGAO
C55	CAP 10pF NPC ±5% 0805	L06731005NGAO
C56	2p7 SM NPO 0805 50V 5%	L06732725NGAO
C57	CAP 6p8 500V 0.5p HIGH Q	L0679682EZXA0
C60	1000p CAP FEEDTHRU FILT	L066XFT102PA0
C61	1000p CAP FEEDTHRU FILT	L066XFT102PA0
C63	CAP 15pF HIGH Q 500V 5%	L06791505ZXAO
D2	BAS16 [SOT 23]	L063SBAS16XA0
D3	BAR18 SOT 23	L063SBAR18XA0
D4	BAR18 SOT 23	L063SBAR18XA0
D5	BAR18 SOT 23	L063SBAR18XA0
D6	BZX84C5V6 [SOT 23]	L063SC5V6XXAO
FL1	EMI SUPPRESSION FILTER	L066DSS102XA0
FL2	EMI SUPPRESSION FILTER	L066DSS102XA0
FL3	EMI SUPPRESSION FILTER	L066DSS102XA0
FL4	EMI SUPPRESSION FILTER	L066DSS102XA0
FL5	EMI SUPPRESSION FILTER	L066DSS102XA0
FL6	100pF EMI SUPP FILTER	L066DSS101XA0
FL7	EMI SUPPRESSION FILTER	L066DSS102XA0
H1	100WPA INLET F.CAN	L004INCANPAAL
H2	100WPA O/P F.CAN	L004OPFILPAB0
H3	TRANSISTOR PAD	L060TRANPADAO
H4	HEATSINK TO-5	L0045FHSINKAO
IC1	BA15532F [S0-8]	L057S5532XXAO
J1	AVDEL AVLUG 1/16"	L0131070208AO
J2	AVDEL AVLUG 1/16"	L0131070208AO
J3	AVDEL AVLUG 1/16"	L0131070208AO
J4	AVDEL AVLUG 1/16"	L0131070208AO
J5	AVDEL AVLUG 1/16"	L0131070208AO
L1	IND 39nH 5% [1008]	L06483935CXAO
L2	10u INDUCTOR CHIP	L0649X103ACA0
L3	SIEMENS B62152A1X1 C	L033PAINDL3AO
L4	9t 1mm WIRE 4mm ID	L033PAINDL4AO
L5	100W P/A INDUCTOR L5	L033PAINDL5B0
L6	100W P/A INDUCTOR L6	L033PAINDL6A1
L7	100W P/A INDUCTOR L7	L033PAINDL7AO
L8	100W P/A OUTPUT STUB	L033PAINDL8B0
L9	IND 39nH 5% [1008]	L06483935CXAO
L10	35nH TUNEABLE IND	L06493530LXAO
L11	35nH TUNEABLE IND	L06493530LXAO
L14	IND 39nH 5% [1008]	L06483935CXAO
PCB1	PA 100W PCB	L001PA100WXB0
PL1	5X2 PIN HEADER	L01305X2TSXAO
R1	RES 4K7 0.125W ±2% 1206	L07144722P8AO
R2	RES 10K 0.125W ±2% 1206	L07141032P8AO
R3	1K5 SM CHIP 1206 2%	L07141522P8AO
R4	RES 10K 0.125W ±2% 1206	L07141032P8AO
R6	RES 4K7 0.125W ±2% 1206	L07144722P8AO
R7	RES 470R 0.125W ±2% 1206	L07144712P8AO
R8	RES 22R 0.125W ±2% 1206	L07142202P8AO
R9	RES 22R 0.125W ±2% 1206	L07142202P8AO
R10	1K5 SM CHIP 1206 2%	L07141522P8AO
R11	27R SM CHIP 1206 2%	L07142702P8AO
R12	27R SM CHIP 1206 2%	L07142702P8AO
R13	RES 3K3 0.125W 2% 1206	L07143322P8AO
R14	10K MULTITURN TRIMMER	L0699103AWCA0
R15	RES 100K 0.125W ±2% 1206	L07141042P8AO
R16	RES 4K7 0.125W ±2% 1206	L07144722P8AO
R17	330R LEADED METAL 3W 5%	L06983315MDAO



R18	RES 3K3 0.125W 2% 1206	L07143322P8A0
R19	10K MULTITURN TRIMMER	L0699103AWCA0
R20	RES 100K 0.125W ±2% 1206	L07141042P8A0
R21	RES 4K7 0.125W ±2% 1206	L07144722P8A0
R22	10R CARBON 1W 5%	L06981005C1A0
R23	RES 1K0 0.125W ±2% 1206	L07141022P8A0
R24	RES 6K2 0.125W ±2% 1206	L07146222P8A0
R25	RES 1K0 0.125W ±2% 1206	L07141022P8A0
R26	RES 4K7 0.125W ±2% 1206	L07144722P8A0
R27	RES 10K 0.125W ±2% 1206	L07141032P8A0
R29	100R SM CHIP 1206 2%	L07141012P8A0
R30	51R SM CHIP 1206 2%	L07145102P8A0
R31	RES 1K0 0.125W ±2% 1206	L07141022P8A0
R32	RES 10K 0.125W ±2% 1206	L07141032P8A0
R33	RES 0R0.125W ±2% 1206	L071400Z2P8A0
R35	RES 0R0.125W ±2% 1206	L071400Z2P8A0
R36	RES 10K 0.125W ±2% 1206	L07141032P8A0
R37	51R SM CHIP 1206 2%	L07145102P8A0
R38	RES 10K 0.125W ±2% 1206	L07141032P8A0
R39	RES 56K 0.125W ±2% 1206	L07144563P8A0
R40	180K SM CHIP 1206 2%	L07141842P8A0
R41	RES 10K 0.125W ±2% 1206	L07141032P8A0
R42	RES 10K 0.125W ±2% 1206	L07141032P8A0
R43	RES 56K 0.125W ±2% 1206	L07144563P8A0
R44	180K SM CHIP 1206 2%	L07141842P8A0
R45	RES 2K2 0.125W ±2% 1206	L07142222P8A0
R47	330R LEADED METAL 3W 5%	L06983315MDA0
SK5	SMB SOCKET PC MOUNT	L013SMBSKPCA0
SK6	50_ SUB MIN COAX CON SM	L013OSMTPCBA0
SK7	50_ SUB MIN COAX CON SM	L013OSMTPCBA0
T1	TRANSFORMER A	L033PATRANA01
T2	TRANSFORMER A	L033PATRANA01
T3	TRNSAFORMER B	L033PATRANBB1
T4	TRANSFORMER C	L033PATRANCA0
T5	TRANSFORMER C	L033PATRANCA0
T6	TRANSFORMER D	L033PATRANDA0
T7	TRANSFORMER D	L033PATRANDA0
T8	TRANSFORMER E	L033PATRANE01
TR1	BC847 SOT23	L060SBC847XA0
TR2	BCX17 SOT23	L060SBCX17XA0
TR3	BC847 SOT23	L060SBC847XA0
TR4	BCW70 SOT23	L060SBCW70XA0
TR5	2N3866 [TO-39]	L0602N3866XA0



Power Amplifier 100W

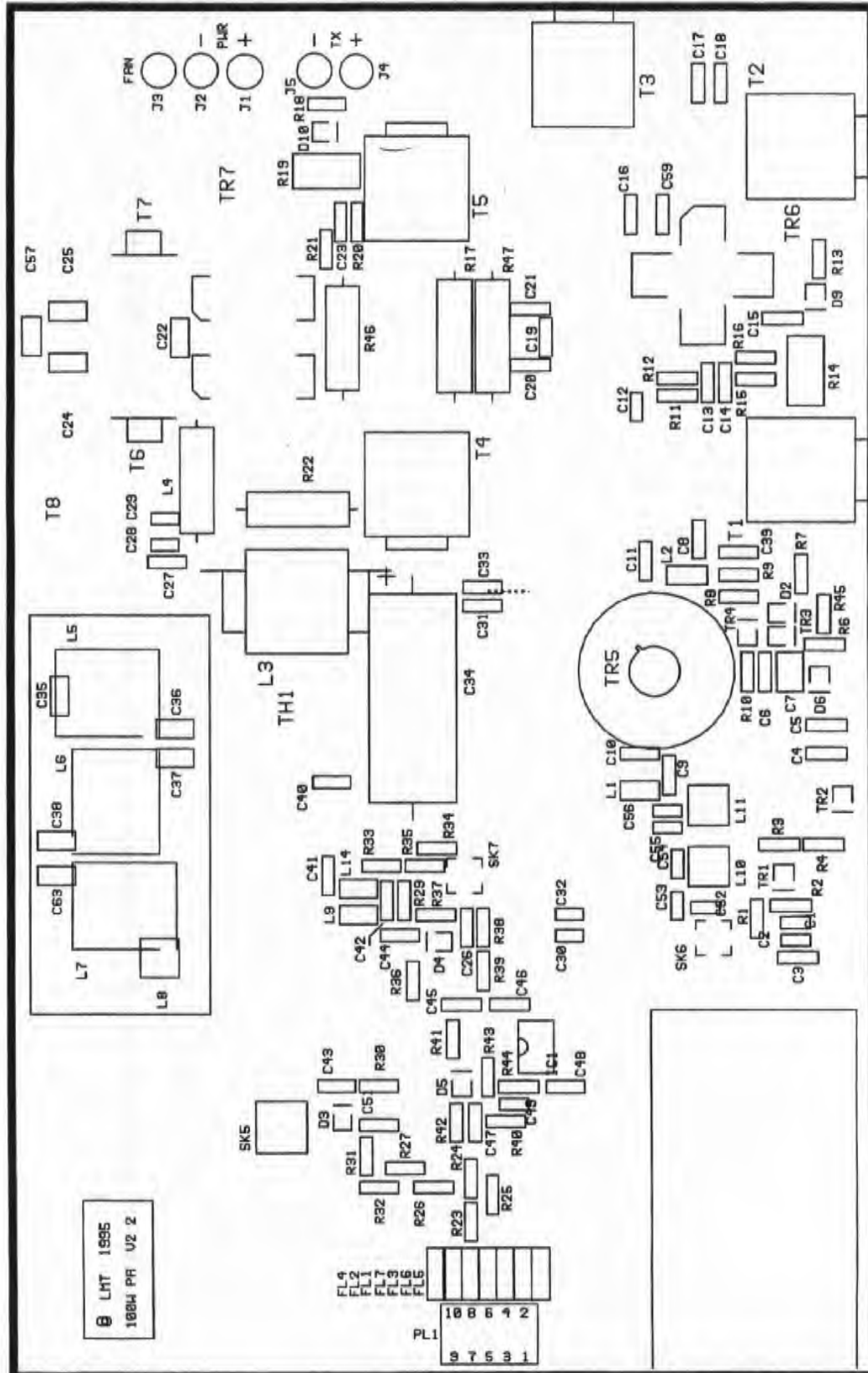

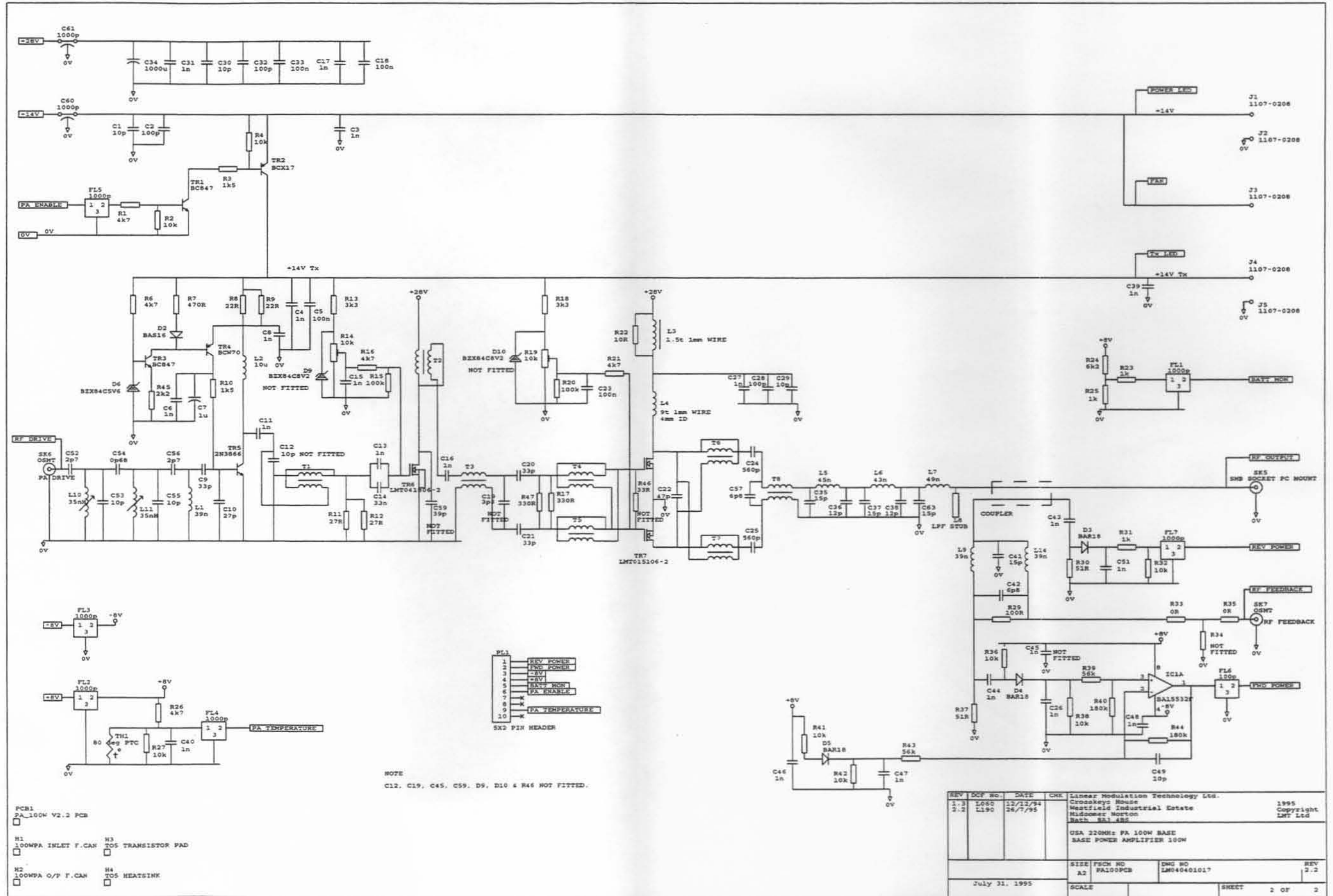



19. Trunking Channel Controller

Contents

General Assemblies	19-3
Chassis.....	19-3
Module Parts List	19-11
Main.....	19-11
Rear.....	19-12
Deselect.....	19-12
Processor.....	19-12
Looms	19-13
LED BRD-TCC Card L033LEDTCCXA0.....	19-13
R/Panel-TCC Card..... L033REARTCCA1.....	19-14
Switch-TCC Card..... L033SWTCCXA2.....	19-16
Filtercon-R/Panel Loom..... L033M3REDXIA0.....	19-17
PCB Parts List	19-19
Main.....	19-19
Front.....	19-23
Rear.....	19-24
Deselect.....	19-25
Overlays	19-26
Main.....	19-26
Front.....	19-27
Rear.....	19-28
Deselect.....	19-29
Processor.....	19-30
Circuit Diagrams	19-31
Main.....	19-31
Front.....	19-33
Rear.....	19-35
Deselect.....	19-37



Module Parts List

Trunking Channel Controller

Document No: LM030300005

Issue 1.1

Quantity	Description	Stock Number
1	CONNECTOR BACK BOX	L004BSH1006A2
1	TCC REAR PANEL	L004BT1603GA1
1	TCC FRONT PANEL	L004BT1604GA1
1	TCC PCB SIDE PANEL	L004BT1605GA3
1	TCC SIDE PANEL	L004BT1606GA4
1	TCC ACCESS PLATE	L004BT1607GA0
1	TCC REGULATOR SPACER	L004TMRSFAXA0
1	TCC RED DISPLAY FILTER	L020TCCFILTA0
1	TCC MAIN PCB INS SHEET	L020TMPCBISB0
1	SERIAL N/D LABEL	L026SNLABELB0
2	102mm CABLE TIE	L029102TIESA0
4	10mm SPACER	L02910SPACEA0
1	M2.5X6 P/HEAD TORX BZCP	L02925P6MMTA0
2	M3X10 CSK TORX BZCP	L0293C10MMTA0
20	M3X6 CSK TORX BZCP	L029M3C6MMTA0
17	M3 CRINKLE WASHER	L029M3CWASHA0
8	M3 NUT BZCP	L029M3NUTXXA0
11	M3X6 PAN HEAD TORX BZCP	L029M3P6MMTA0
12	M3-UNC4 LOCKING SCREWS	L029M3UNCLSA0
11	M3 PLAIN WASHER BZCP	L029M3WASHPA0
2	M3 SHAKEPROOF WASHER	L029M3WASHSA0
2	M5 FIBRE WASHER	L029M5FWASHA0
6	SLEEVE 3 x 20 RUBBER	L0323X20SLVA0
0.02	TCW 22 SWG	L032TCW22WGA0
1	LED BRD-TCC CARD	L033LEDTCCXA0
1	FILTERCON-R/PANEL LOOM	L033M3REDXIA0
1	R/PANEL-TCC CARD	L033REARTCCA1
1	POWER LOOM RX/TCC	L033RXLR3IXA1
1	SWITCH-TCC CARD	L033SWTCCXXA2
1	48.3mm HANDLE M3X8 FIX	L035HANDLES A0
2	S/A C/TIE CLAMP	L035SATIECLA0
1	TOGGLE SWITCH 101 PTM	L051T105LHZA0
-1	TOGGLE SWITCH 10 PTM	L051T108LHZA0
1	1000PF FILTER CON	L066PC1000PA0T



PROJECTION :-

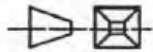

START SK1		FINISH SK2
PIN	FUNCTION	PIN
1	ENABLE	1
2	DATA	2
3	CLK	3
4	COMP RF CARRIER	4
5	LED 2 (IN SERV)	5
6	LED 1 (CONTROL)	6
7	VSS	7
8	VCC	8
9	LED 3 (PTT+)	9
10	LED 3 (PTT-)	10
11	LED 4 (TALK+)	11
12	LED 4 (TALK-)	12
13	N/U	13
14	N/U	14

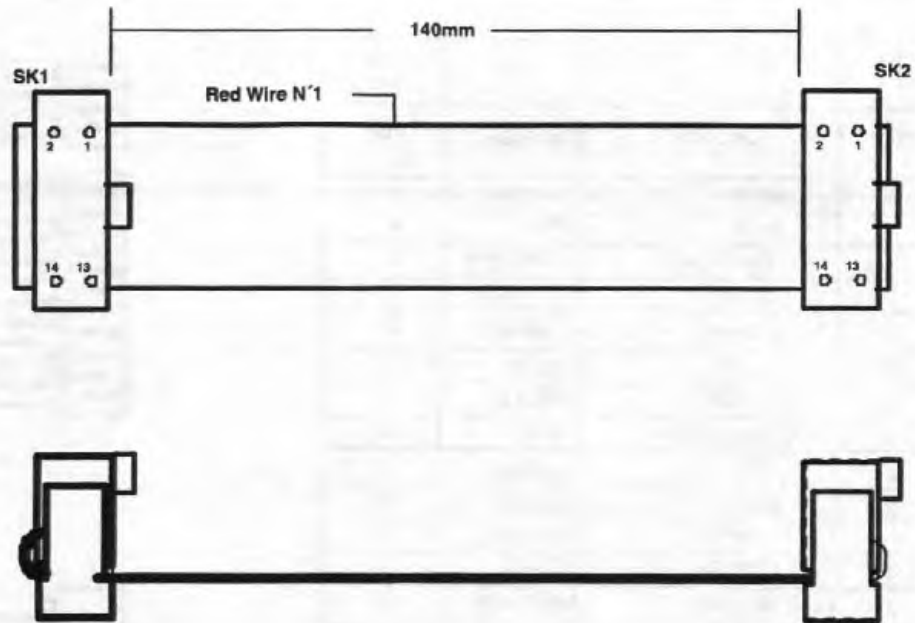

SK1/SK2 :- BUMP-POLARISED IDC 14-WAY TYPE THOMAS-BETTS 622-1441 (or equivalent i.e. Farnell 152-719).

CABLE :- IDC RIBBON CABLE, GREY 0.05 PITCH (RED LEADING EDGE FOR WIRE N°1).

Note 1 :- Direction of cable entry reversed on SK2.

DRW:- 8LMT0005.L71	TITLE :-	MAT :-	DRAWN :- B.PERRETT.
ISSUE :- 1.0	LED BOARD-TCC CARD 1.0. (Part L033LEDTCCXA0)	TOL :- ±10mm.	DATE :- 9.2.95.



TRUNKING CHANNEL CONTROLLER

PROJECTION :-

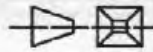

START SK1	START SK2			FINISH SK3
PIN	PIN	FUNCTION	COLOUR	PIN
1		COMP	BROWN	1
2		TRUE	RED	2
3		Not Used	ORANGE	3
4		AUXO	YELLOW	4
	1	LIFU STA	GREEN	5
	2	LIFU IS	BLUE	6
	3	LIFU LCL	VIOLET	7
	4	DATA CHANNEL	GREY	8
	5	SCL	WHITE	9
	6	SDA	BLACK	10
	7	FFSK TX	BROWN	11
	8	FFSK RX	RED	12
	9	GLORST	ORANGE	13
	10	+5V	YELLOW	14
	11	+12V	GREEN	15
	12	GRD	BLUE	16

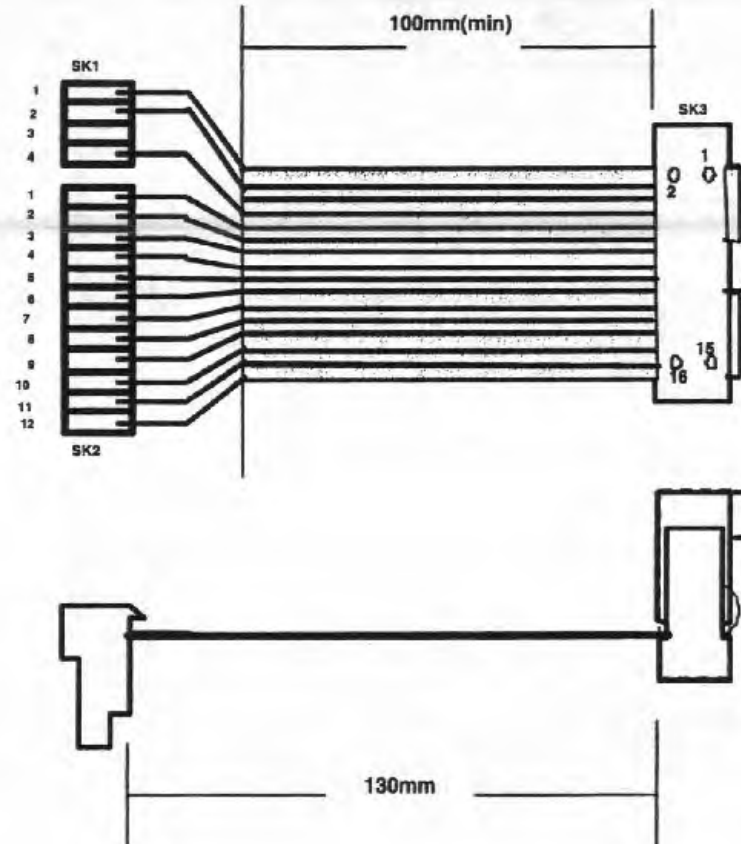

Revisions

A1 :- 6.3.95
 SK1/SK2 were
 AMP type.
 Note 3 added.
 Drawing Number
 now Part Number
 DCF L111.

WIRE TYPE :- PVC insulated 28AWG 16-way 0.05 pitch ribbon.
 (3M style 2776 or equivalent).

SK1 :- IDC connector type MOLEX 38-00-2094 (7720S Series).

SK2 :- IDC connector type MOLEX 38-00-2102 (7720S Series).

SK3 :- IDC bump-polarised type Thomas and Betts 622-1641 (or equivalent)

Note 1 :- Attention is drawn to the duplication of some colours.

Note 2 :- In the final installation the sockets SK1 and SK2 mount side by side on a single axis.

Note 3 :- A single 16-way Molex connector type 38-00-2106 replacing SK1/SK2 is acceptable and is the preferred build.

DRW:-L033REARTCC

TITLE :-

SHEET :- 1 OF 2.

DRAWN :- B.PERRETT.

ISSUE :- A1

R/PANEL-TCC CARD 1.0.

TOL :- 10mm

DATE :- 6.3.95.

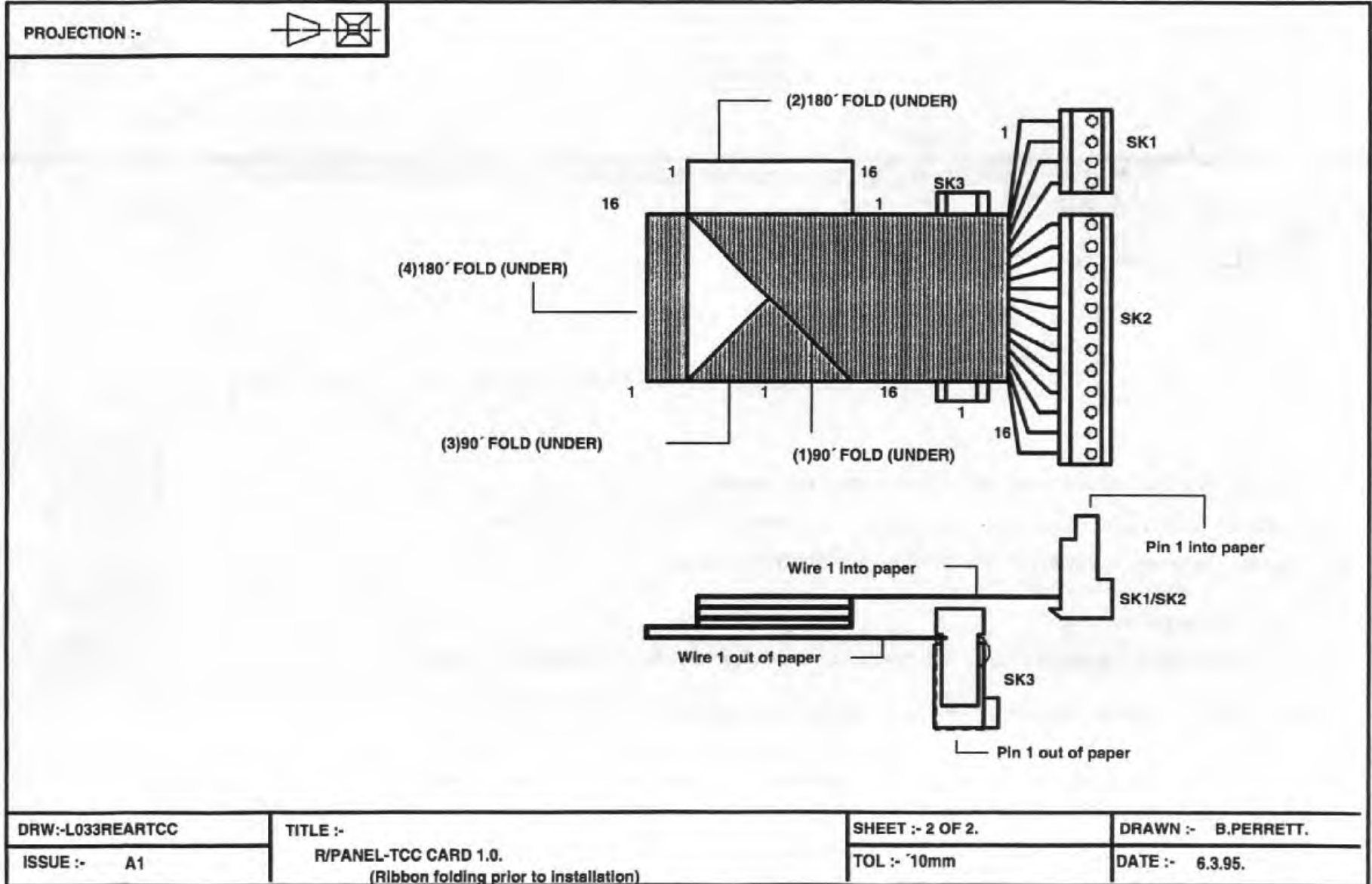

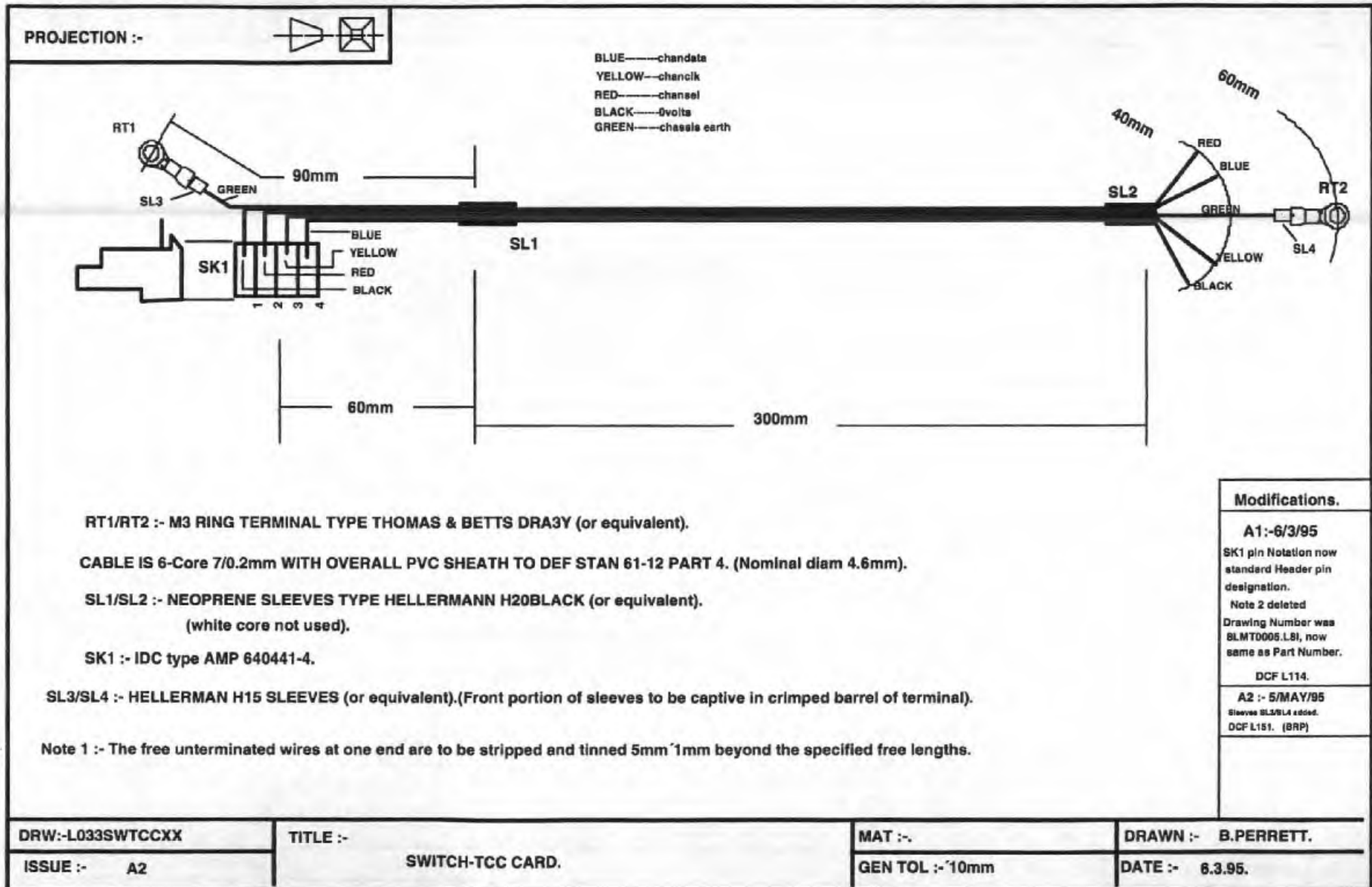

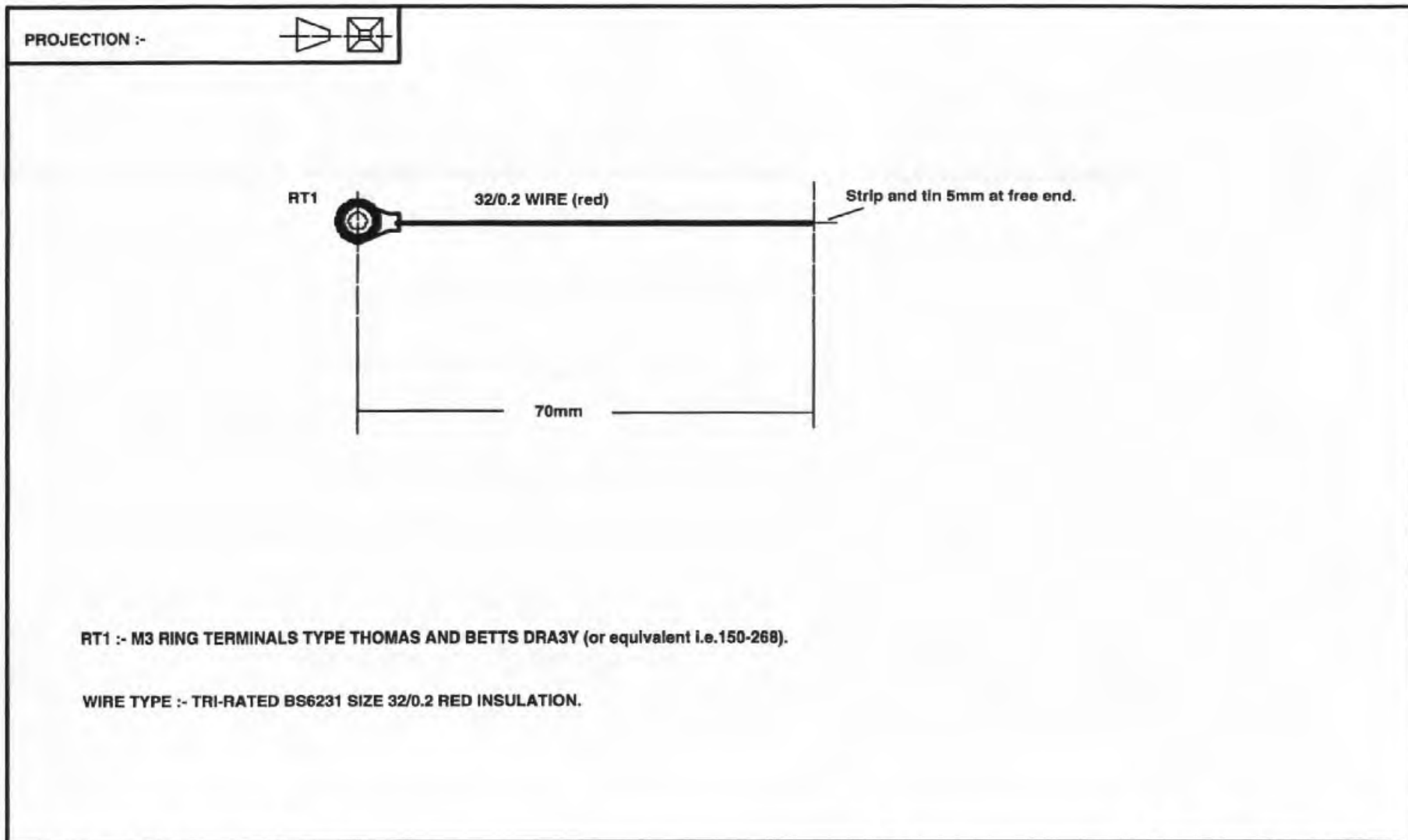

RT1 :- M3 RING TERMINALS TYPE THOMAS AND BETTS DRA3Y (or equivalent i.e.150-268).

WIRE TYPE :- TRI-RATED BS6231 SIZE 32/0.2 RED INSULATION.

DRW:- 8LMT0005.L2I	TITLE :-	MAT :-	DRAWN :- B.PERRETT.
ISSUE :- 1.0	FILTERCON-R/PANEL LOOM. (Part L033M3REDXI)	FIN :-	DATE :- 18.4.94.



Trunking Channel Controller Main

Software Parts List

Document No: LM030500013		Issue 1.0
Reference	Description	Stock Number
IC13	S/WARE TCC MODEM	L058TCCMODMB0
IC20	S/WARE TCC MAIN	L058TCCMAINB0

PCB Parts List

Document No: LM030400018		Issue 1.0
Reference	Description	Stock Number
BCD1	PCB MTG SWITCH (HORZ)	L051BCDSWXXA0
BCD2	PCB MTG SWITCH (HORZ)	L051BCDSWXXA0
BCD3	PCB MTG SWITCH (HORZ)	L051BCDSWXXA0
BCD4	PCB MTG SWITCH (HORZ)	L051BCDSWXXA0
BCD5	PCB MTG SWITCH (HORZ)	L051BCDSWXXA0
C1	4n7 POLYESTER	L066472POLYA0
C2	0.01uF POLYESTER	L066103POLYA0
C2	22uF 16V TANT	L066226TANTA0
C3	0.01uF POLYESTER	L066103POLYA0
C3	0.033uF 63V POLYESTER	L066333POLYA0
C4	0.01uF POLYESTER	L066103POLYA0
C4	22uF 16V TANT	L066226TANTA0
C5	4.7uF 16V TANT	L066475TANTA0
C6	0.1uF POLYESTER	L066104POLYA0
C6	0.01uF POLYESTER	L066103POLYA0
C7	0.01uF POLYESTER	L066103POLYA0
C7	1uF 35V TANT	L066105TANTA0
C8	4.7uF 16V TANT	L066475TANTA0
C9	0.01uF POLYESTER	L066103POLYA0
C10	4n7 POLYESTER	L066472POLYA0
C11	0.01uF POLYESTER	L066103POLYA0
C11	0.1uF POLYESTER	L066104POLYA0
C12	0.01uF POLYESTER	L066103POLYA0
C13	1nF POLYESTER	L066102POLYA0
C13	0.01uF POLYESTER	L066103POLYA0
C14	100pF 100V MULTILAYER	L0669101ANXA0
C14	0.01uF POLYESTER	L066103POLYA0
C16	0.01uF POLYESTER	L066103POLYA0
C17	0.01uF POLYESTER	L066103POLYA0
C18	0.01uF POLYESTER	L066103POLYA0
C19	0.01uF POLYESTER	L066103POLYA0
C21	0.01uF POLYESTER	L066103POLYA0
C21	220pF CERAMIC	L06692215NXA0
C23	0.01uF POLYESTER	L066103POLYA0
C24	0.01uF POLYESTER	L066103POLYA0
C25	0.01uF POLYESTER	L066103POLYA0



C26	0.01uF POLYESTER	L066103POLYAO
C35	100pF 100V MULTILAYER	L0669101ANXAO
C36	CAP 47uF 25V ELECT	L0660476BEEAO
C37	0.47uF 35V TANT	L066474TANTA0
C38	0.22uF 35V TANT	L066224TANTA0
C39	0.47uF 35V TANT	L066474TANTA0
C40	0.22uF 35V TANT	L066224TANTA0
CN1	8x2WAY SHROUDED HDR 0.1"	L0138X2SHRDAO
CN2	4 X 1 FRICTION PIN H/DR	L0134X1PINLAO
CN3	2WAY PIN HEADER 0.1"	L0132WPINXXAO
CN4	8 X 2 PIN HEADER	L01308X2TSXAO
D1	1N4148	L063C1N4148AO
D2	DIODE 4V7 ZENER	L0634V7ZENXAO
D3	1N4148	L063C1N4148AO
D4	DIODE 30V ZENER	L06330VZENXAO
D5	DIODE 4V7 ZENER	L0634V7ZENXAO
D6	1N4148	L063C1N4148AO
D9	DIODE 30V ZENER	L06330VZENXAO
D10	DIODE 30V ZENER	L06330VZENXAO
D11	DIODE 30V ZENER	L06330VZENXAO
D12	DIODE 30V ZENER	L06330VZENXAO
D13	DIODE 30V ZENER	L06330VZENXAO
D18	DIODE BAT42	L063BAT42XXAO
D19	DIODE BAT42	L063BAT42XXAO
D20	1N4148	L063C1N4148AO
D21	1N4148	L063C1N4148AO
D22	1N4148	L063C1N4148AO
D23	1N4148	L063C1N4148AO
D24	1N4148	L063C1N4148AO
D25	1N4148	L063C1N4148AO
D26	1N4148	L063C1N4148AO
D27	1N4148	L063C1N4148AO
D28	1N4148	L063C1N4148AO
D29	1N4148	L063C1N4148AO
D30	1N4148	L063C1N4148AO
D31	1N4148	L063C1N4148AO
D32	1N4148	L063C1N4148AO
D33	1N4148	L063C1N4148AO
D34	1N4148	L063C1N4148AO
D35	1N4148	L063C1N4148AO
D36	1N4148	L063C1N4148AO
D37	1N4148	L063C1N4148AO
D38	1N4148	L063C1N4148AO
D39	1N4148	L063C1N4148AO
D40	DIODE 1N4001	L063C1N4001AO
D41	DIODE BAT42	L063BAT42XXAO
D42	DIODE BAT42	L063BAT42XXAO
D43	DIODE BAT42	L063BAT42XXAO
D44	DIODE BAT42	L063BAT42XXAO
D45	DIODE BAT42	L063BAT42XXAO
D46	DIODE BAT42	L063BAT42XXAO
DC1	0.01uF POLYESTER	L066103POLYAO
DC5	10uF LEADED TANT 16V 20%	L0669106BBCA0
DC10	10uF LEADED TANT 16V 20%	L0669106BBCA0
DC15	10uF LEADED TANT 16V 20%	L0669106BBCA0
DC22	10uF LEADED TANT 16V 20%	L0669106BBCA0
IC1	IC 74HCT02 (DIL14)	L057HCT02XXAO
IC2	IC 74HCT04 (DIL14)	L057HCT04XXAO
IC3	14WAY IC SOCKET	L013DIL14XXAO
IC3	14WAY TP IC SOCKET	L013DIL14TPAO
IC4	IC 4521 (DIL16)	L0574521XXXXAO
IC5	IC HD6321P (DIL40)	L057HD6321PA0
IC6	IC HD6303RP (DIL40)	L057HD6303XAO



IC6	40WAY IC SOCKET	L013DIL40XXA0
IC7	IC 74F138 (DIL16)	L05774F138XA0
IC8	IC FX419J (DIL22)	L057FX419JXA0
IC9	IC TL081CN (DIL8)	L057TL081CNA0
IC10	IC 74HCT157 (DIL16)	L057HCT157XA0
IC11	IC 74HCT157 (DIL16)	L057HCT157XA0
IC12	IC 74HCT157 (DIL16)	L057HCT157XA0
IC13	28WAY IC SOCKET	L013DIL28XXA0
IC14	IC 4521 (DIL16)	L0574521XXXXA0
IC15	IC 74HCT245 (DIL20)	L057HCT245XA0
IC16	IC 74HCT245 (DIL20)	L057HCT245XA0
IC17	IC 74HCT244 (DIL20)	L057HCT244XA0
IC18	40WAY IC SOCKET	L013DIL40XXA0
IC18	IC HD6303RP (DIL40)	L057HD6303XA0
IC19	IC HD6321P (DIL40)	L057HD6321PA0
IC20	28WAY IC SOCKET	L013DIL28XXA0
IC21	28WAY IC SOCKET	L013DIL28XXA0
IC21	8K X 8 TIMEKEEPER RAM	L057MK48T18A0
IC22	IC 74F138 (DIL16)	L05774F138XA0
IC23	IC DS8820N (DIL14)	L057DS8820NA0
IC24	IC DS8831N (DIL16)	L057DS8831NA0
IC25	28WAY IC SOCKET	L013DIL28XXA0
IC25	IC HM62256ALP-10 (DIL28)	L05762256XXA0
PCB	TCC MAIN BOARD	L001TCCMAINB0
R1	10K LEADED 0.25W 5%	L06991035C4A0
R2	100K LEADED 0.25W 5%	L06991045C4A0
R3	220R LEADED 0.25W 5%	L06992211M4A0
R4	10K LEADED 0.25W 5%	L06991035C4A0
R5	10K LEADED 0.25W 5%	L06991035C4A0
R6	4K7 LEADED 0.25W 5%	L06994725C4A0
R7	4K7 LEADED 0.25W 5%	L06994725C4A0
R8	10K LEADED 0.25W 5%	L06991035C4A0
R9	10K LEADED 0.25W 5%	L06991035C4A0
R10	10K LEADED 0.25W 5%	L06991035C4A0
R11	2K2 LEADED 0.25W 5%	L06992225M4A0
R12	18R LEADED 0.25W 5%	L06991801C2A0
R13	10K LEADED 0.25W 5%	L06991035C4A0
R14	3K9 RES LEADED 0.25W 5%	L06993921C2A0
R15	10K LEADED 0.25W 5%	L06991035C4A0
R16	10K LEADED 0.25W 5%	L06991035C4A0
R17	100K LEADED 0.25W 5%	L06991045C4A0
R18	10K LEADED 0.25W 5%	L06991035C4A0
R19	10K LEADED 0.25W 5%	L06991035C4A0
R20	10K LEADED 0.25W 5%	L06991035C4A0
R21	10K LEADED 0.25W 5%	L06991035C4A0
R22	10K LEADED 0.25W 5%	L06991035C4A0
R23	220R LEADED 0.25W 5%	L06992211M4A0
R24	220R LEADED 0.25W 5%	L06992211M4A0
R25	10K LEADED 0.25W 5%	L06991035C4A0
R26	1K LEADED 0.25W 5%	L06991025C4A0
R28	1K2 RES LEADED 0.25W 5%	L06991221C2A0
R29	2K2 LEADED 0.25W 5%	L06992225M4A0
R30	220R LEADED 0.25W 5%	L06992211M4A0
R31	2K2 LEADED 0.25W 5%	L06992225M4A0
R32	2K2 LEADED 0.25W 5%	L06992225M4A0
R33	2K2 LEADED 0.25W 5%	L06992225M4A0
R36	1K LEADED 0.25W 5%	L06991025C4A0
R37	1K LEADED 0.25W 5%	L06991025C4A0
R38	1K LEADED 0.25W 5%	L06991025C4A0
R39	1K LEADED 0.25W 5%	L06991025C4A0
R40	1K LEADED 0.25W 5%	L06991025C4A0
R41	10K LEADED 0.25W 5%	L06991035C4A0
REG1	7805 REGULATOR (TO220)	L0577805REGA0



REG2	7805 REGULATOR (TO220)	L0577805REGA0
RN1	10K 9 PIN 8 RES SIL NET	L06910KNETXA0
RN2	10K 9 PIN 8 RES SIL NET	L06910KNETXA0
TR1	TRANSISTOR ZTX300	L060ZTX300XA0
TR2	TRANSISTOR ZTX300	L060ZTX300XA0
TR4	TRANSISTOR ZTX300	L060ZTX300XA0
TR5	TRANSISTOR ZTX300	L060ZTX300XA0
TR6	TRANSISTOR ZTX300	L060ZTX300XA0
VR1	20K PRESET POT	L06920KPOTXA0
XL1	CRYSTAL 4.032 MHz	L0554M032XXA0



Trunking Channel Controller Front

PCB Parts List

Document No: LM030400019

Issue 1.1

Reference	Description	Stock Number
CAP1	0.01uF POLYESTER	L066103POLYAO
CAP2	CAP 470uF 6.3V ELECT	L0668477DEAAO
CON1	8 X 2 PIN HEADER	L01308X2TSXAO
CON4	8 X 2 PIN HEADER	L01308X2TSXAO
DIS1	RED 7 SEGMENT DISPLAY	L054REDDISPAO
DIS2	RED 7 SEGMENT DISPLAY	L054REDDISPAO
DIS3	RED 7 SEGMENT DISPLAY	L054REDDISPAO
DIS4	RED 7 SEGMENT DISPLAY	L054REDDISPAO
IC1	IC MC14499P	L05714499PXA0
LED1	LED SPACER	L020LEDSPCRAO
LED1	RED LED 5mm	L055RED5MMXA0
LED2	LED SPACER	L020LEDSPCRAO
LED2	RED LED 5mm	L055RED5MMXA0
LED3	LED SPACER	L020LEDSPCRAO
LED3	YELLOW LED 5mm	L055YELL5MMAO
LED4	LED SPACER	L020LEDSPCRAO
LED5	GREEN LED 5mm	L055GRN5MMXA0
LED5	LED SPACER	L020LEDSPCRAO
PCB	TCC DISPLAY PCB	L001TCCDISPAO
R1	82R LEADED 0.25W 5%	L06998201C2AO
R2	82R LEADED 0.25W 5%	L06998201C2AO
R3	82R LEADED 0.25W 5%	L06998201C2AO
R4	82R LEADED 0.25W 5%	L06998201C2AO
R5	82R LEADED 0.25W 5%	L06998201C2AO
R6	82R LEADED 0.25W 5%	L06998201C2AO
R7	82R LEADED 0.25W 5%	L06998201C2AO
R8	82R LEADED 0.25W 5%	L06998201C2AO
R9	4R7 LEADED 0.25W 5%	L069947Z5C4AO
R10	1K LEADED 0.25W 5%	L069910Z5C4AO
TR1	ZTX300 [TO 92,E-LINE]	L060LZTX300AO
TR2	ZTX300 [TO 92,E-LINE]	L060LZTX300AO
TR3	ZTX300 [TO 92,E-LINE]	L060LZTX300AO
TR4	ZTX300 [TO 92,E-LINE]	L060LZTX300AO



Trunking Channel Controller Rear

PCB Parts List

Document No: LM030400020**Issue 1.2**

Reference	Description	Stock Number
10	M3 8MM M/F SPACER	L029M38MMFA0
10	M3 NUT BZCP	L029M3NUTXXA0
10	M3 PLAIN WASHER BZCP	L029M3WASHPA0
A1	AVDEL AVSERT M2.5 X 5mm	L0131176555A0
PCB1	TCC REAR PANEL I/F PCB	L001TCCRPCBA0
PL1	D-TYPE 9W PLUG	L013DT9WPLXA1
PL2	D-TYPE 15W PLUG	L013DT15WPLA1
PL4	16X1 TERMINAL STRIP .1"	L01316X1TSXA0
RLA1	RELAY 4PDT	L051RL4PDTXA0
SK1	D-TYPE 9W SOCKET	L013DT9WSKXA1
SK2	D-TYPE 15W SOCKET	L013DT15WSKA1
SK3	D-TYPE 15W SOCKET	L013DT15WSKA1



Trunking Channel Controller Deselect

PCB Parts List

Document No: LM030400030**Issue 1.0**

Reference	Description	Stock Number
1	14WAY DIL THROUGH HDR	L013DILHDRXA0
C1	CAP 22pF 5% 50V 1206	L0672201206A0
C2	CAP 22pF 5% 50V 1206	L0672201206A0
D1	DIODE LL103B (SMD)	L060LL103BXA0
D2	DIODE LL103B (SMD)	L060LL103BXA0
IC1	74HC00 [SO-14]	L057HC00SXXA0
PCB1	TCC DESELECT PCB	L001CUC04XXA0
R1	RES 2K2 0.125W ±2% 1206	L07142222P4A0
R2	RES 2K2 0.125W ±2% 1206	L07142222P4A0

Trunking Channel Controller Processor

Document No: LM030400035**Issue 1.0**

Reference	Description	Stock Number
1	TCC PROCESSOR BOARD	L001TCCPRO1A0
2	20W SINGLE ROW THRU HDR	L01320WSHDRA0
1	40WAY IC SOCKET	L013DIL40XXA0
16	RES 100R 0.063W 2% 0603	L07121012P6A0



Trunking Channel Controller Main

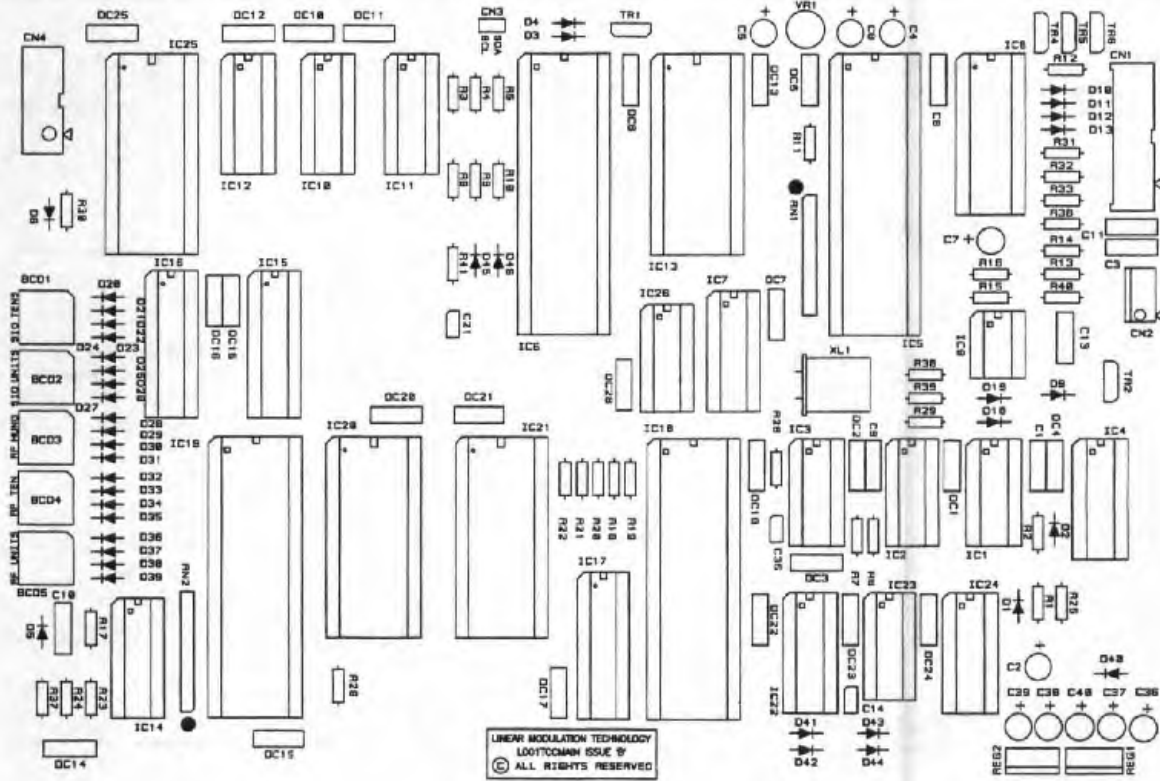



TCC Front

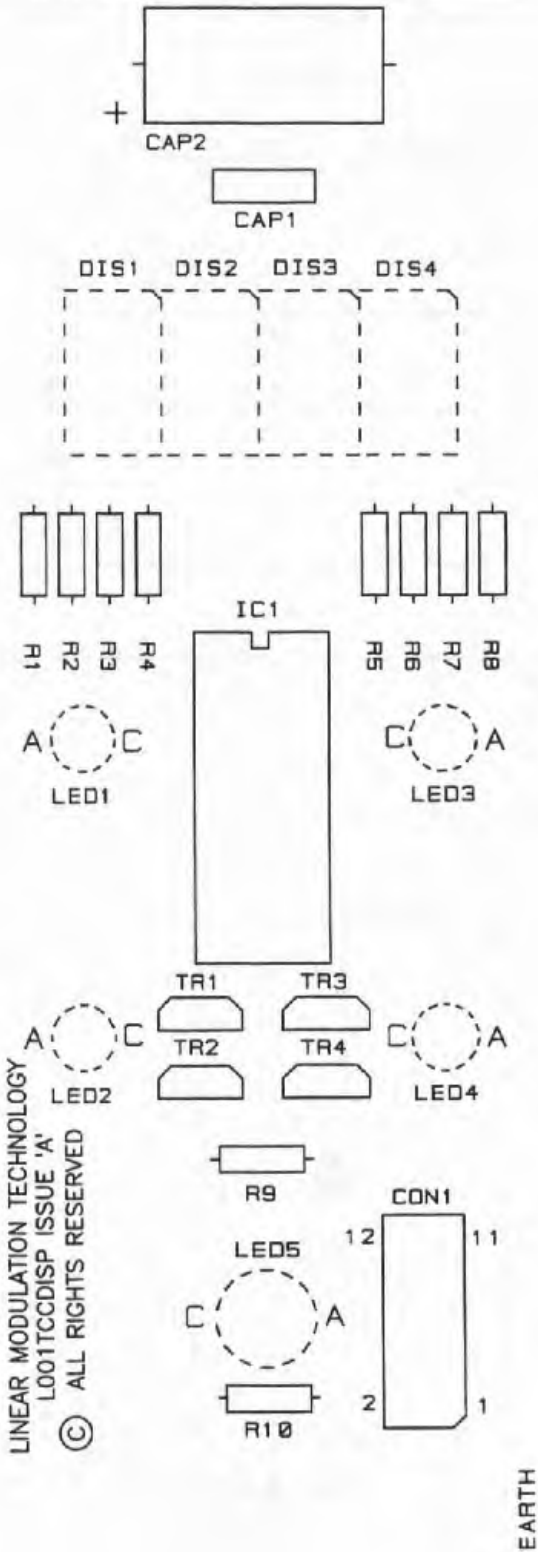

LINEAR MODULATION TECHNOLOGY
 L001TCCDISP ISSUE 'A'
 © ALL RIGHTS RESERVED



TCC Rear

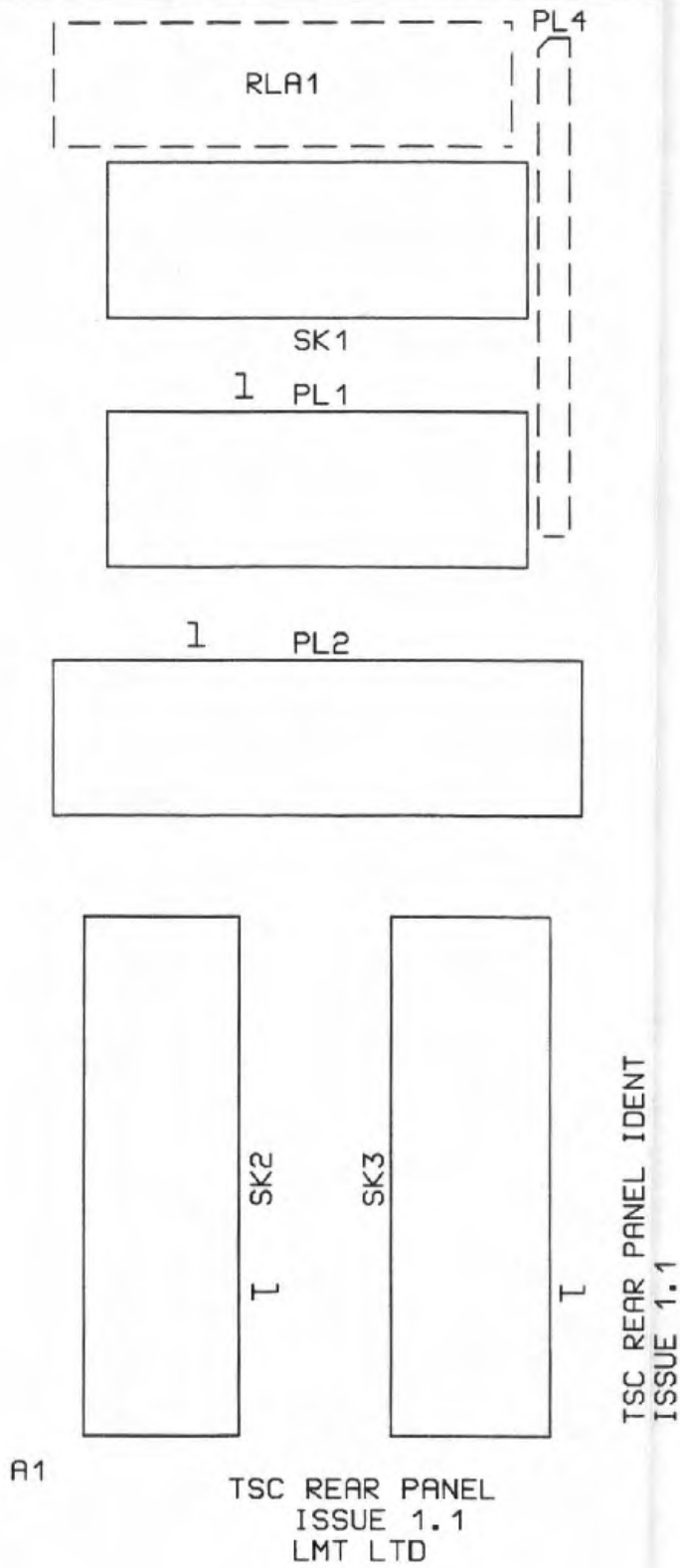



TCC Deselect

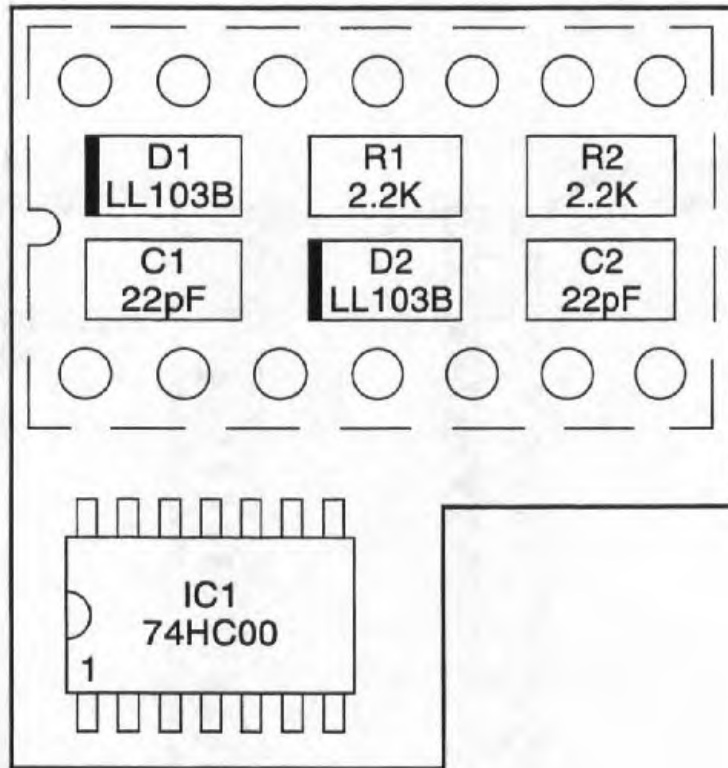



TCC Processor

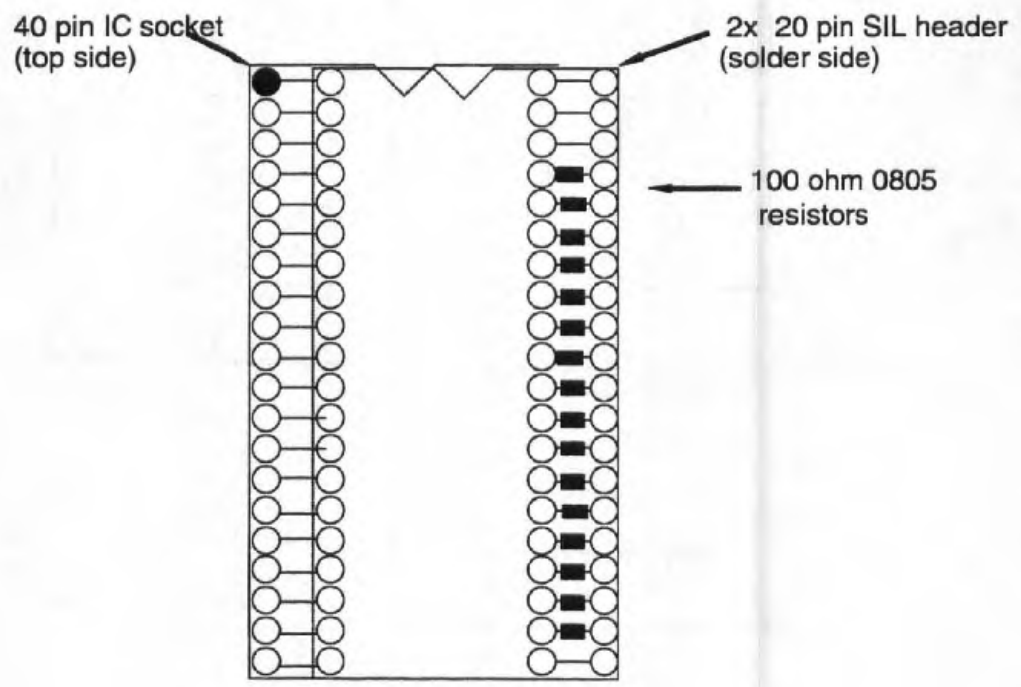

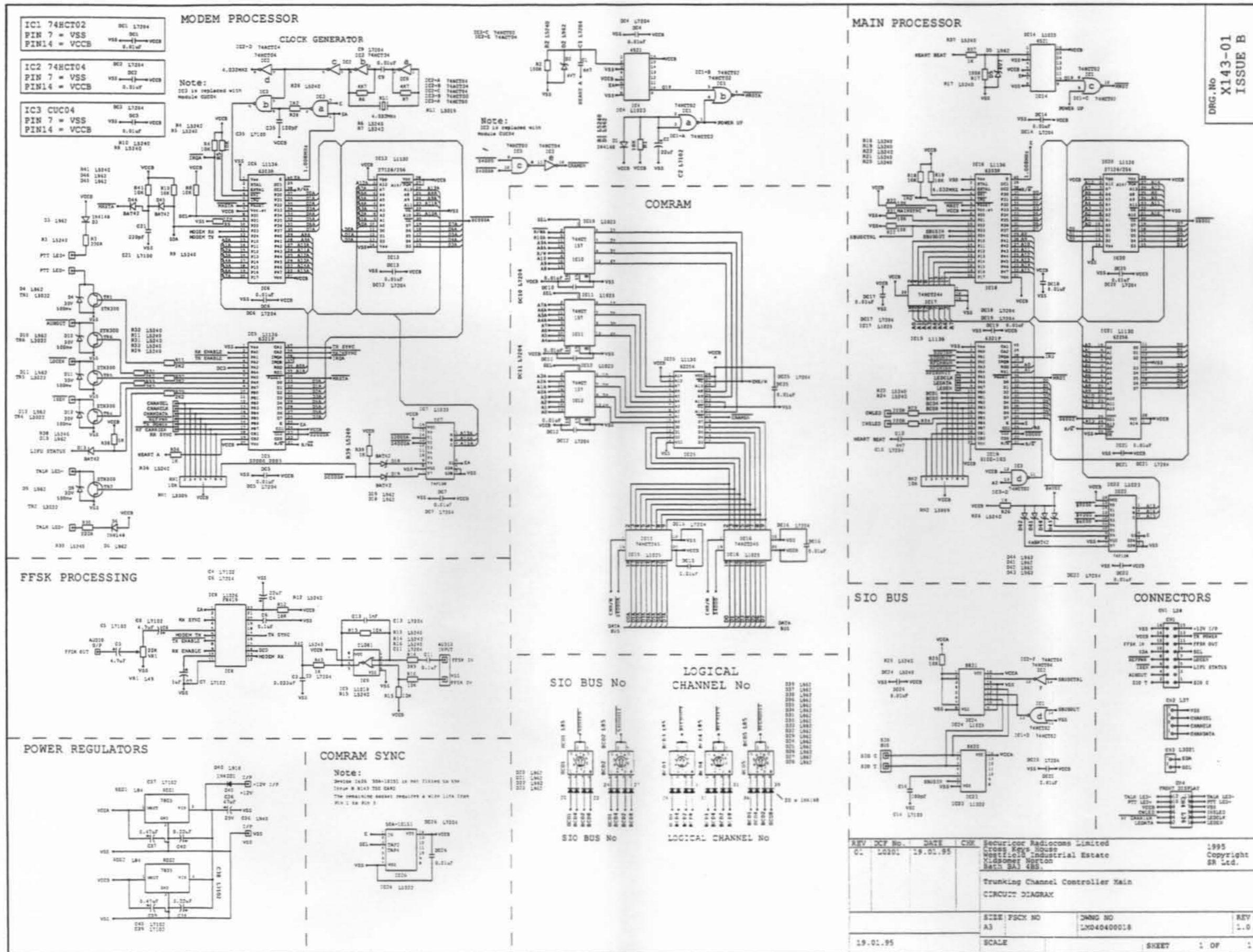

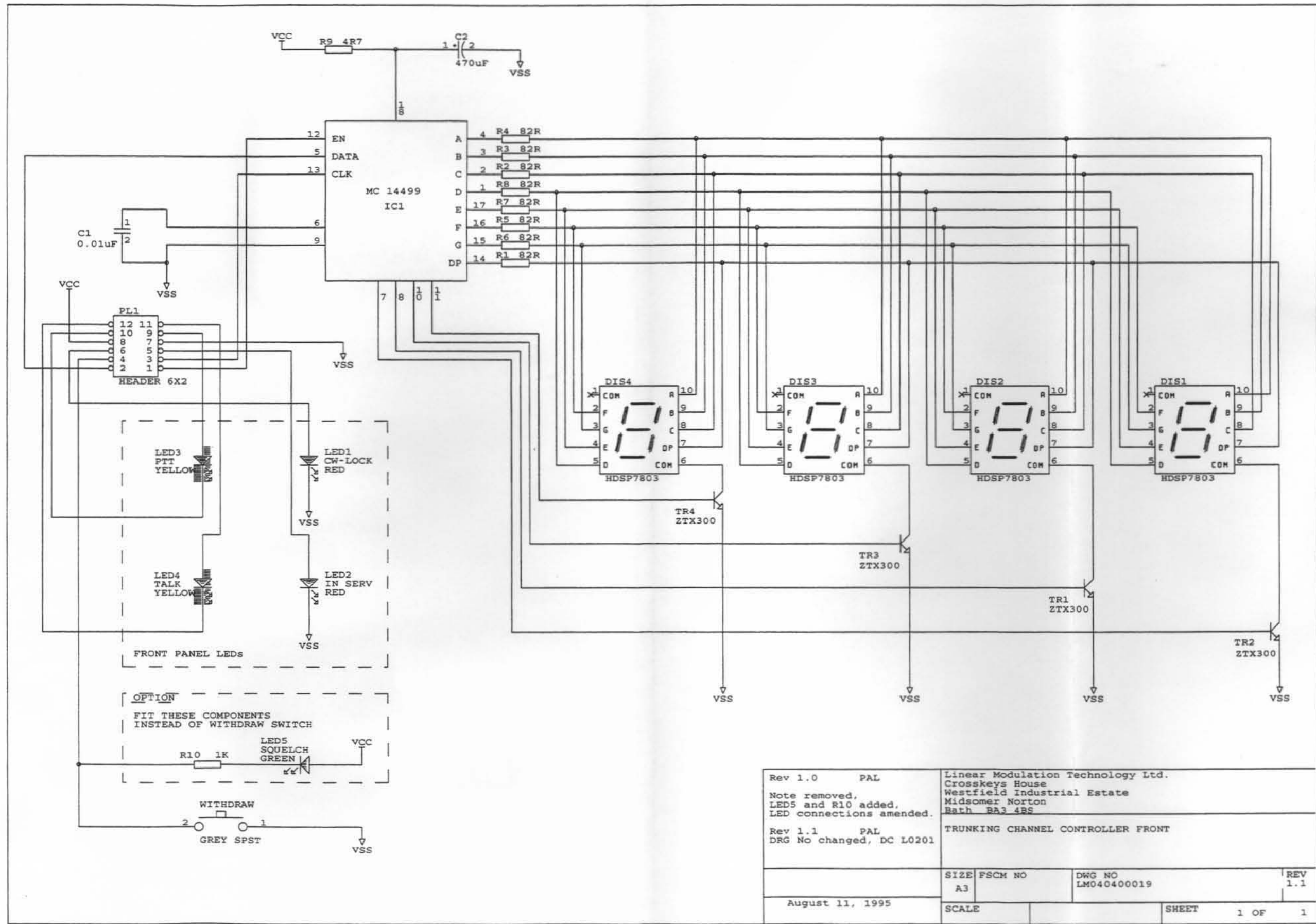

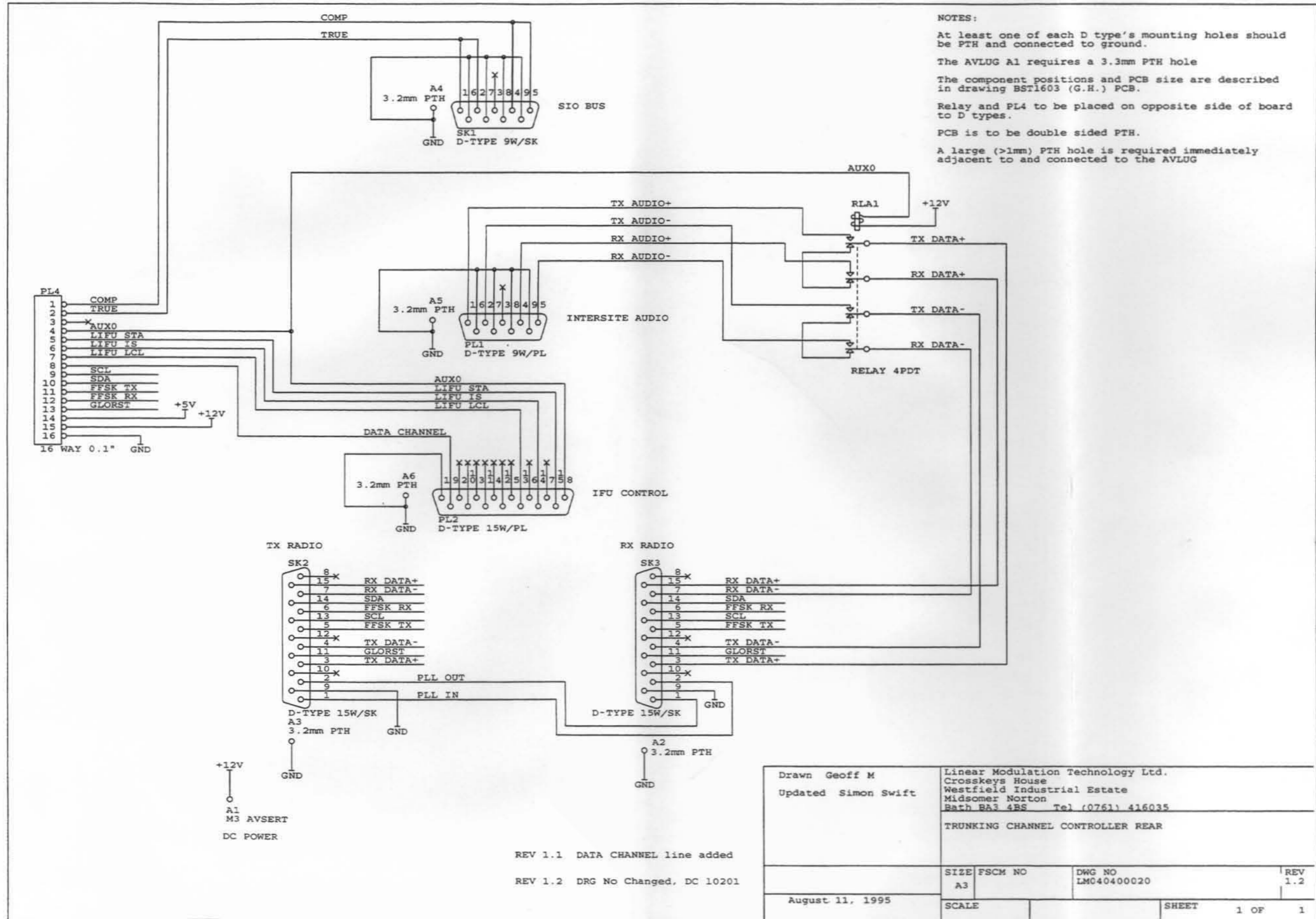

NOTES:
 At least one of each D type's mounting holes should be PTH and connected to ground.
 The AVLUG A1 requires a 3.3mm PTH hole
 The component positions and PCB size are described in drawing BST1603 (G.H.) PCB.
 Relay and PL4 to be placed on opposite side of board to D types.
 PCB is to be double sided PTH.
 A large (>1mm) PTH hole is required immediately adjacent to and connected to the AVLUG

+12V
 A1
 M3 AVSERT
 DC POWER

REV 1.1 DATA CHANNEL line added
 REV 1.2 DRG No Changed, DC 10201

Drawn Geoff M Updated Simon Swift		Linear Modulation Technology Ltd. Crosskeys House Westfield Industrial Estate Midsomer Norton Bath BA3 4BS Tel (0761) 416035	
TRUNKING CHANNEL CONTROLLER REAR			
August 11, 1995	SIZE A3	FSCM NO LM040400020	DWG NO LM040400020
	SCALE	SHEET 1 OF	REV 1.2 1

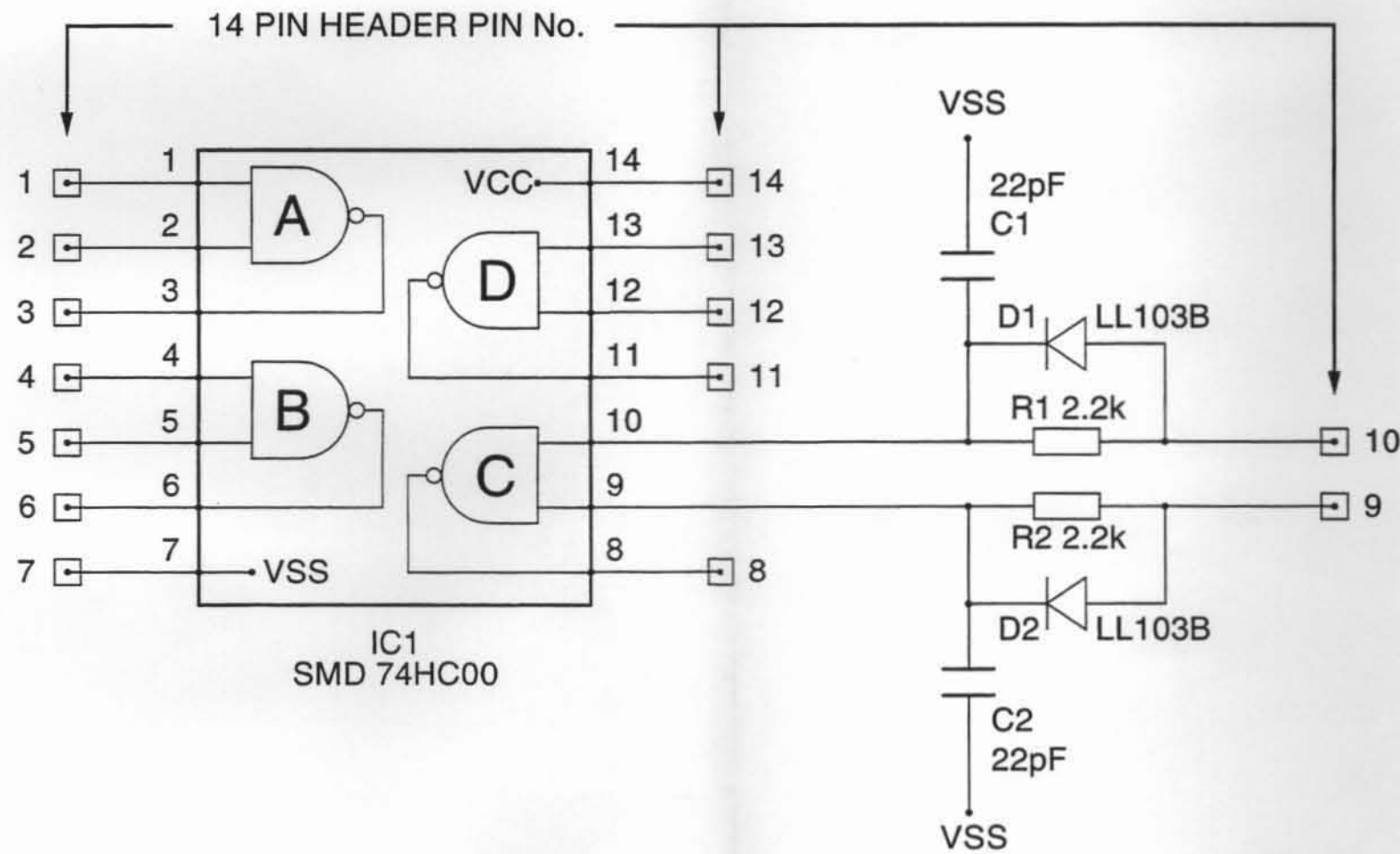

DRG No changed. No L0201	Securitor Radiocom Limited Cross Keys House Westfield Industrial Estate Widmore Norton Bath BA3 4BS.			1995 Copyright SR Ltd.
	Trunking Channel Controller Deselect CIRCUIT DIAGRAM			
	SIZE A3	PSCK NO	DWG NO LMD40400030	REV 1.0
August 11, 1995	SCALE		SHEET	1 OF 1

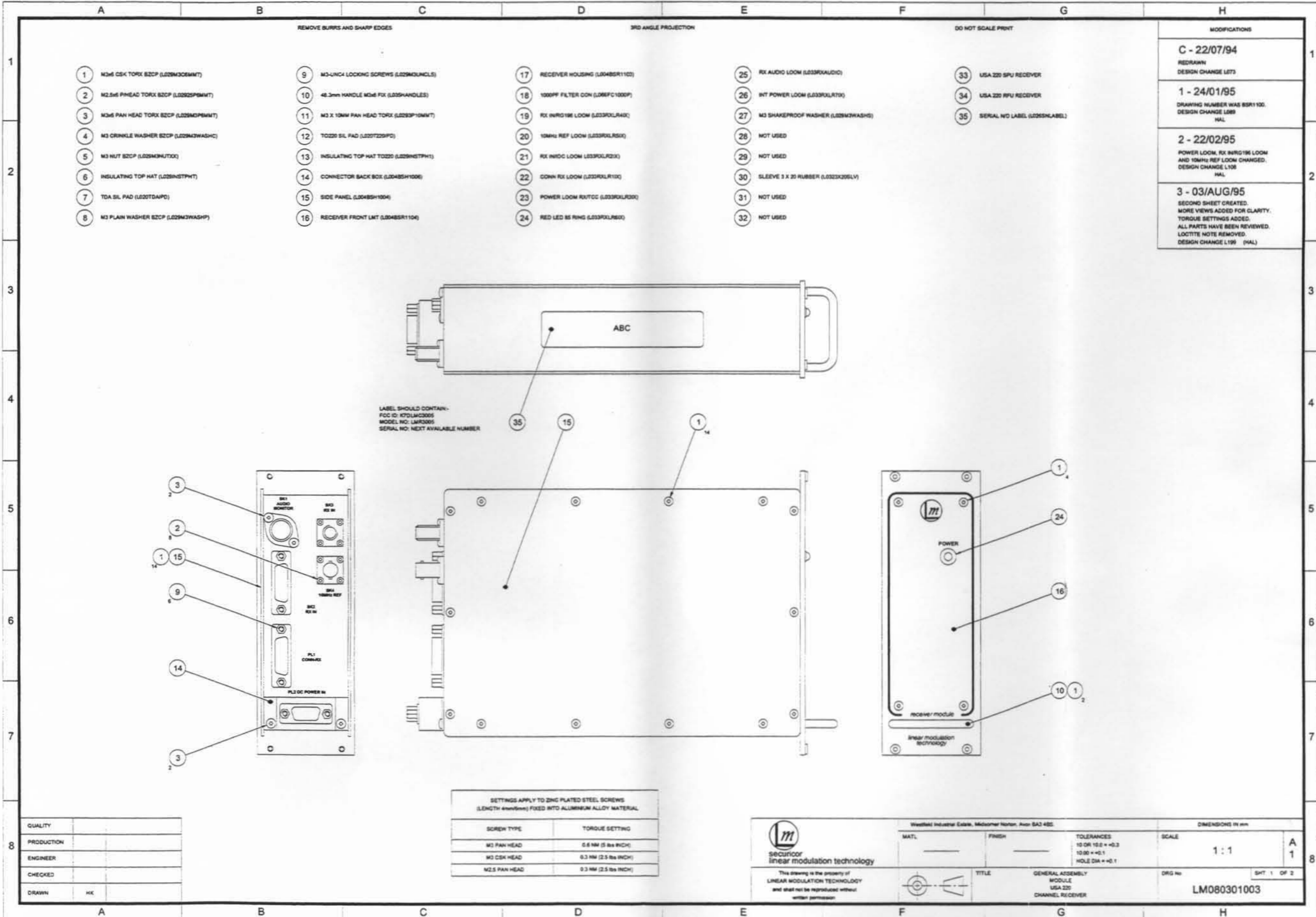

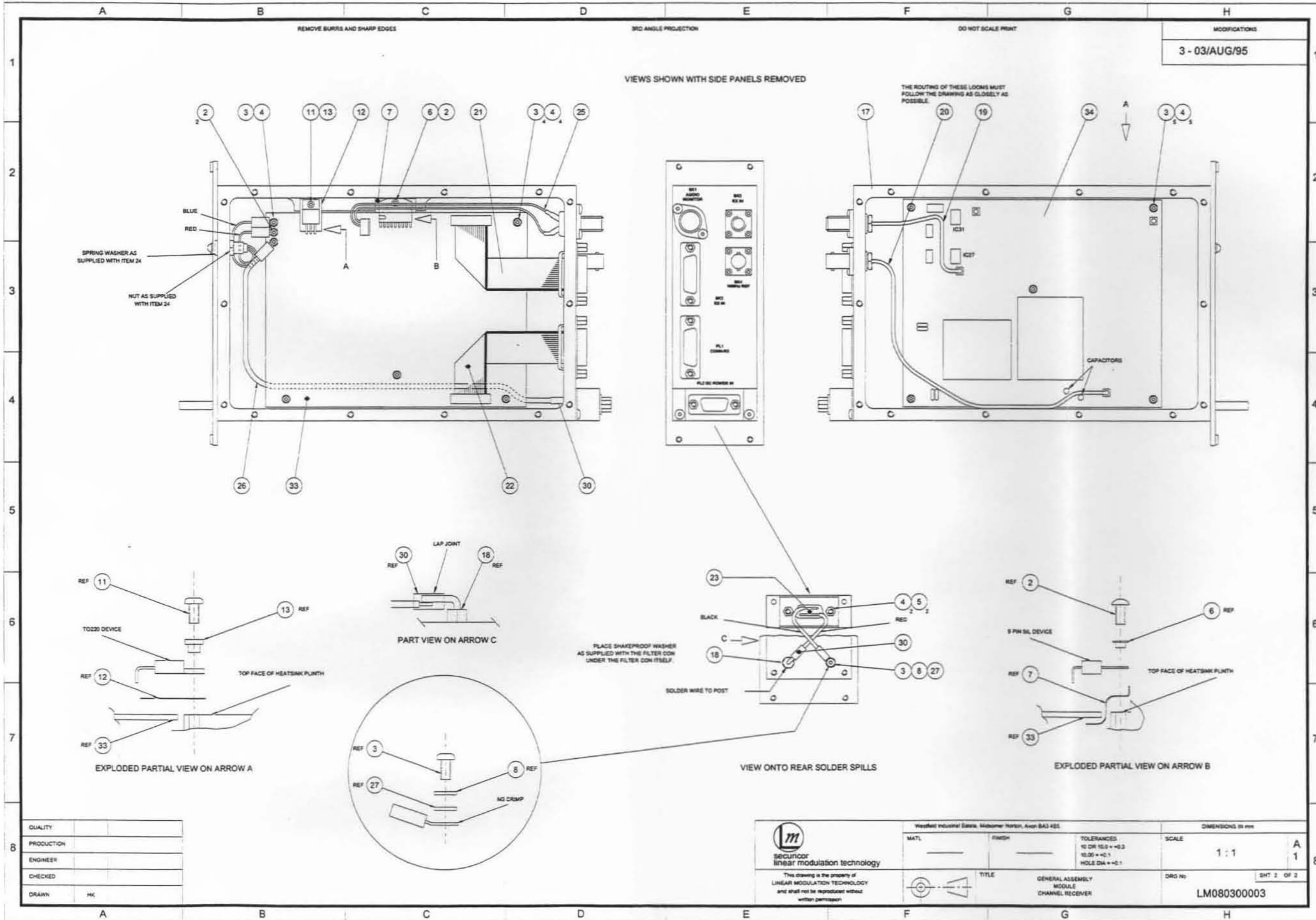

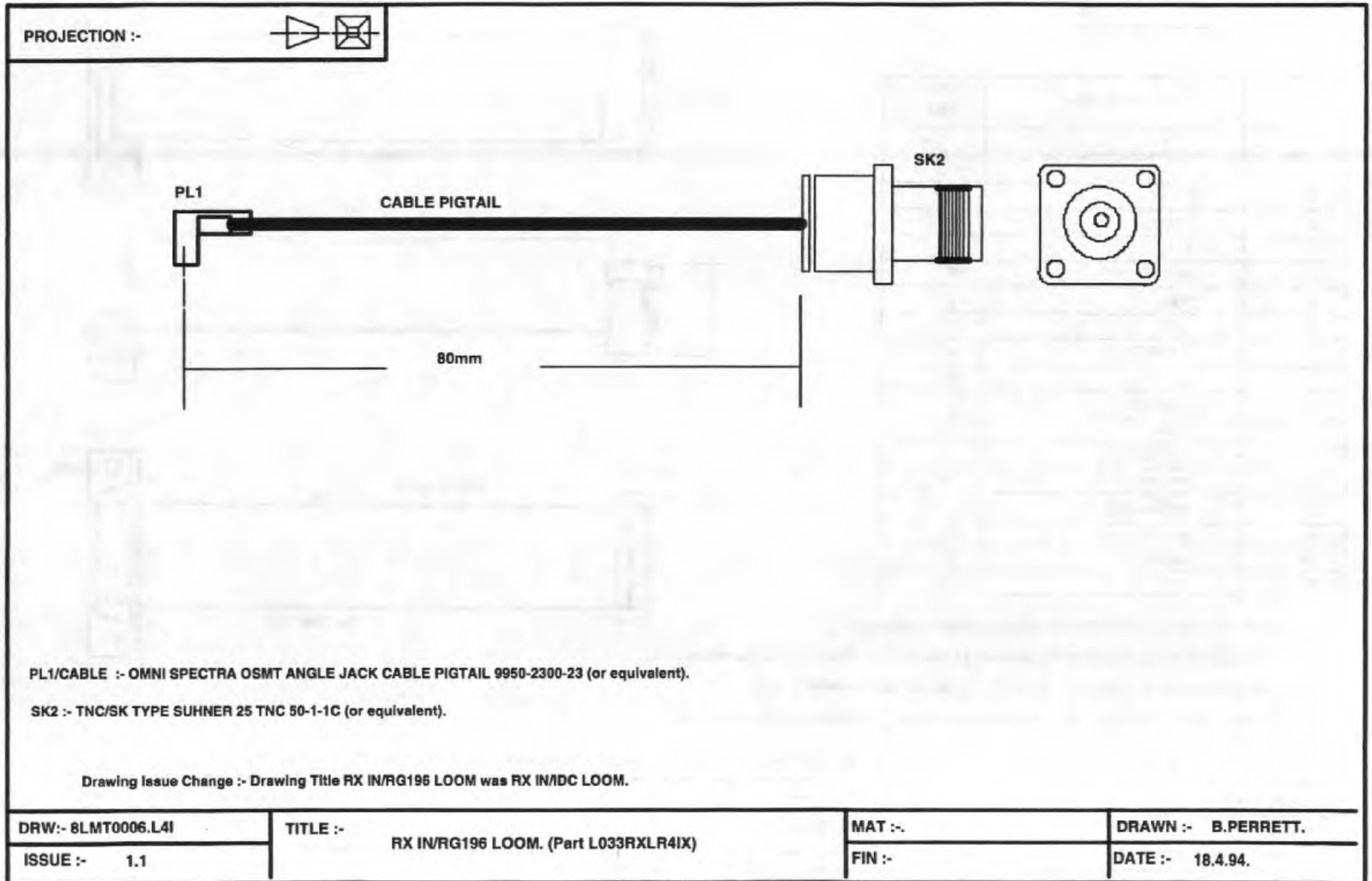



PROJECTION :-



START SK1	SEPARATION 85mm	FINISH SK2
PIN	FUNCTION	PIN
1	PLL IN	1
2	PLL OUT	9
3	RXD	2
4	RTS	10
5	TXD	3
6	CTS	11
7	SPARE 1	4
8	SPARE 2	12
9	SER GRD	5
10	GRD 2	13
11	TX DATA (-)	6
12	TX DATA (+)	14
13	RX DATA (-)	7
14	RX DATA (+)	15
15	GRD 1	8
16		---

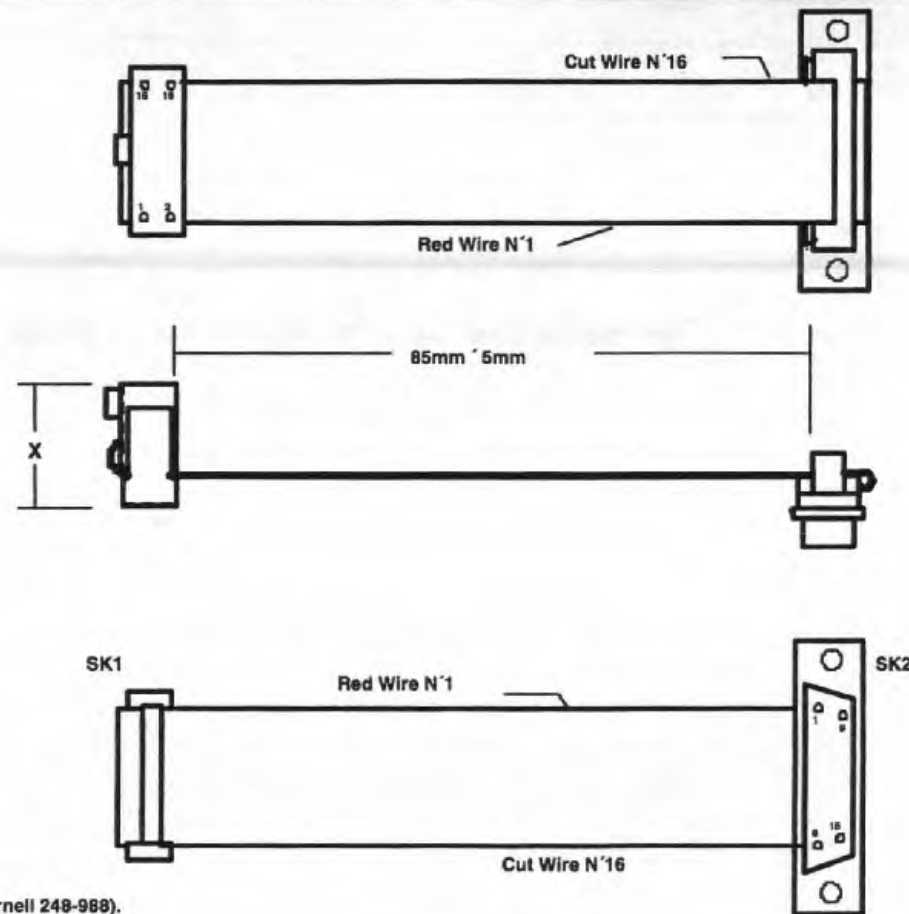

SK2 :- METAL D IDC SOCKET 15-WAY TYPE CINCH FC15S (or equivalent).

SK1 :- BUMP-POLARISED IDC 16-WAY TYPE HARTING 09185166813 (or equivalent i.e. Farnell 248-988).

CABLE :- IDC RIBBON CABLE, GREY 0.05 PITCH (RED LEADING EDGE FOR WIRE N'1).

Note :- Overall height of SK1 with strain relief to not exceed 15.5mm max (dimension X).

Drawing Up-issue :- SK1 connector type changed/ Note 1 ammended/ Length corrected to original 85mm nom.

DRW:- 8LMT0006.L2I	TITLE :-	MAT :-	DRAWN :- B.PERRETT.
ISSUE :- 1.2	RX IN/DC LOOM. (Part L033RXLR2IX)	FIN :-	DATE :- 18.4.94.

CHANNEL RECEIVER UNIT

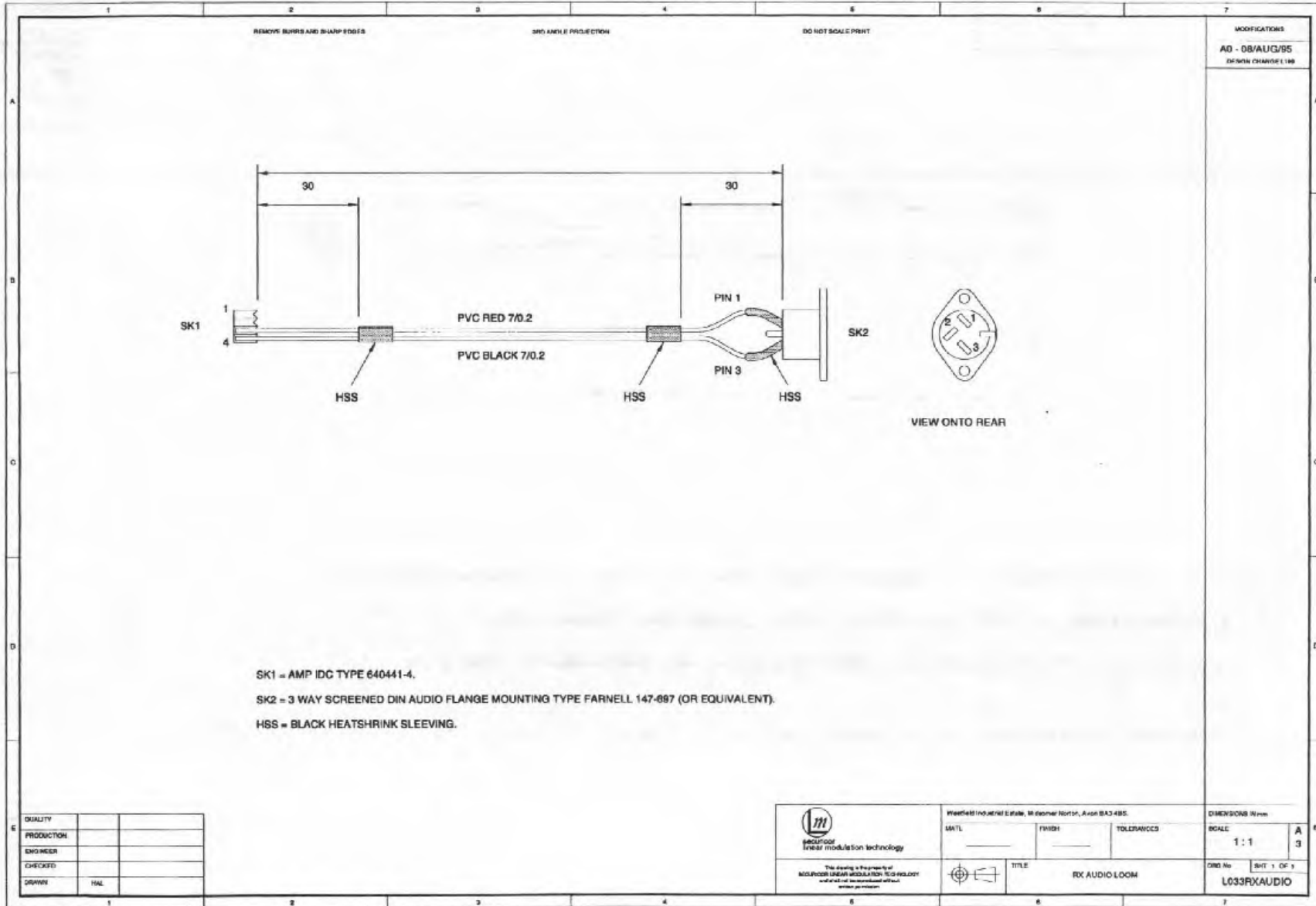



PROJECTION :-



Modifications.

1.0 :- 18.4.94

A1 :- 5/MAY/95

Sleeves added.
DRW was SLMT0006.Lst
DRW N' now Part N'
Note amended.
DCF L151. (BRP)

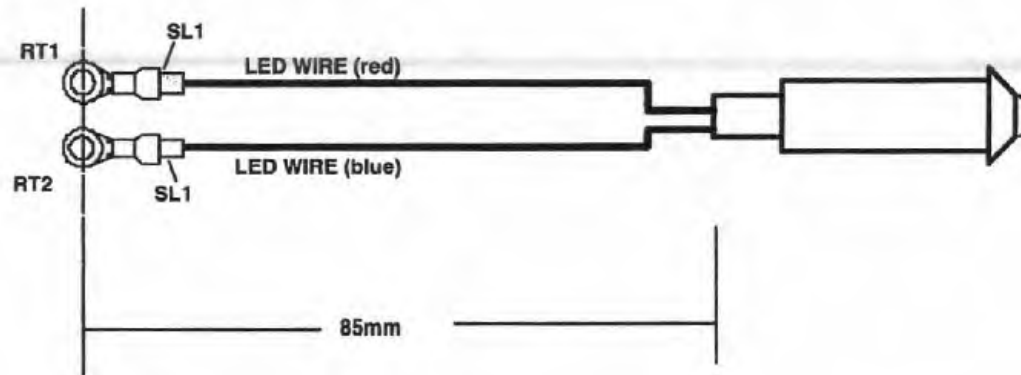

SL1/SL2 :- HELLERMAN H15 SLEEVES (or equivalent).(Front portion of sleeves to be captive in crimped barrel of terminal).

RT1/RT2 :- M3 RING TERMINALS TYPE THOMAS AND BETTS DRA3Y (or equivalent i.e. Farnell 150-268).

PANEL MOUNTING LED :- TYPE HERO SMRD 080-82. (Red) (To be supplied with Spring Washer and Locking Nut)

NOTE :- LED is supplied with red and blue 7/0.2 wires attached and all fixings. Load sleeves, cut wires to specified length and crimp to RT1/RT2.

DRW:- L033RXLR6IX

TITLE :-
RED LED 85 RING.

MAT :-

DRAWN :- B.PERRETT.

ISSUE :- A1

TOL :- '10mm

DATE :- 18.4.94.

CHANNEL RECEIVER UNIT

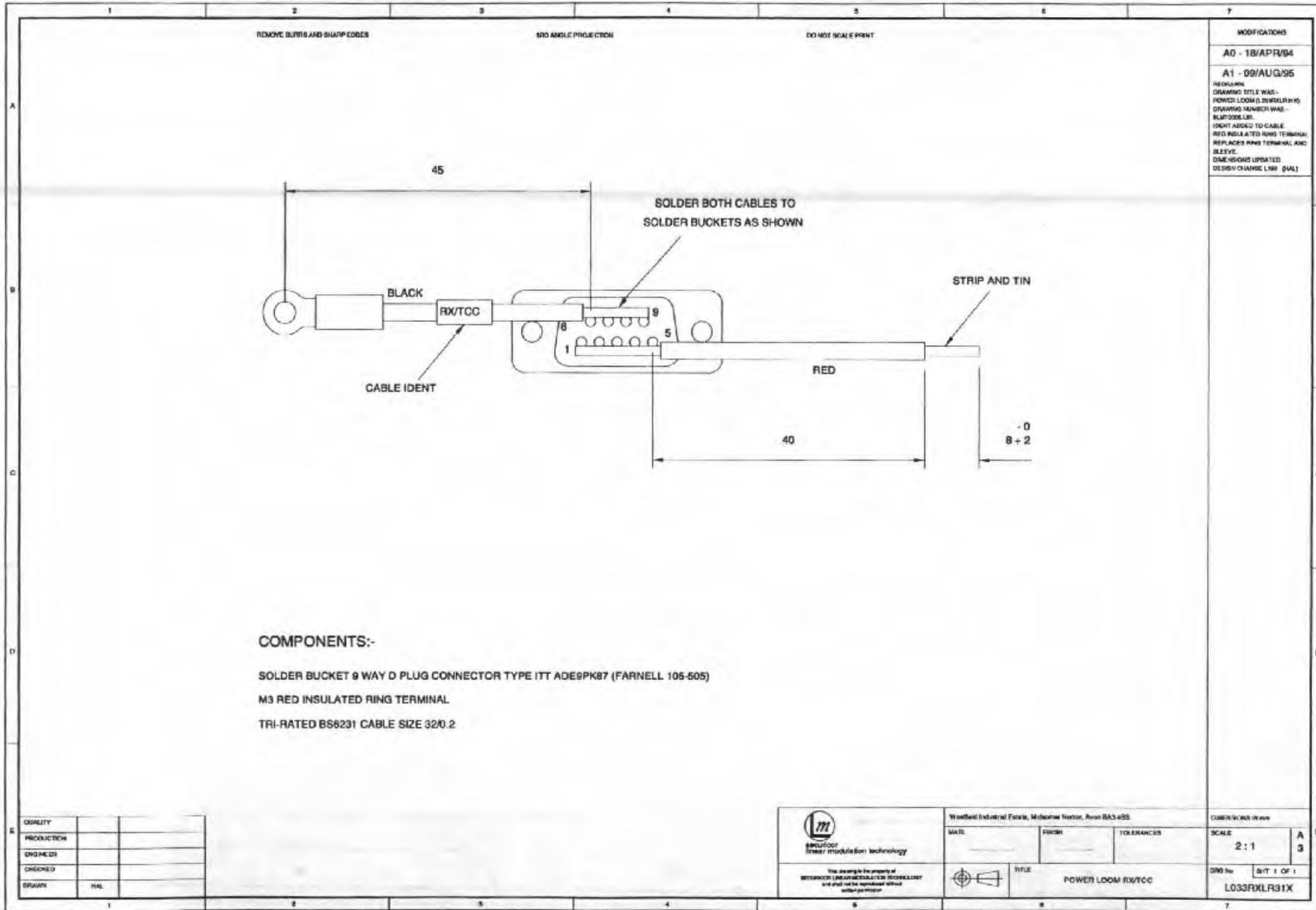

MODIFICATIONS
 A0 - 18/APR/84
 A1 - 09/AUG/95
 REDRAWN
 DRAWING TITLE WAS -
 POWER LOOM (SINGLEWAY)
 DRAWING NUMBER WAS -
 L033RXLR91X
 LIGHT ASSEMBY TO CABLE
 RED INSULATED RING TERMINAL
 REPLACES RING TERMINAL AND
 BEEFIE.
 DIMENSIONS UPDATED.
 DESIGN CHANGE L99 (VAL)

- COMPONENTS:-**
- SOLDER BUCKET 9 WAY D PLUG CONNECTOR TYPE ITT ADE9PK87 (FARNELL 105-505)
 - M3 RED INSULATED RING TERMINAL
 - TRI-RATED BS6231 CABLE SIZE 32X0.2

QUALITY		
PRODUCTION		
ENGINEER		
CHECKED		
DRAWN	HAL	

<p>Worfield Industrial Estate, Midsummer Norton, Avon BA3 4BS</p>	DATE: _____ FINISH: _____ TOLERANCES: _____		DRAWN BY: _____ SCALE: 2:1 A3
	TITLE: POWER LOOM RX/TCC		DRW No: L033RXLR91X 1 OF 1



PROJECTION :-

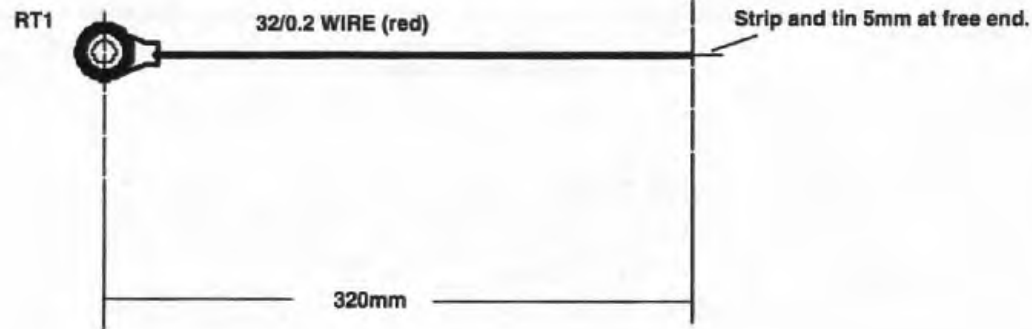
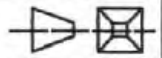

RT1 :- M3 RING TERMINALS TYPE THOMAS AND BETTS DRA3Y (or equivalent i.e. Farnell 150-268).

WIRE TYPE :- TRI-RATED BS6231 SIZE 32/0.2 RED INSULATION.

DRW:- 8LMT0006.L7I

TITLE :-

MAT :-

DRAWN :- B.PERRETT.

ISSUE :- 1.0

INTERNAL POWER LOOM. (Part L033RXLR7IXA0)

FIN :-

DATE :- 18.4.94.

CHANNEL RECEIVER UNIT



PROJECTION :-

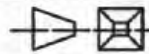

START SK1	SEPARATION 85mm	FINISH PL1
PIN	FUNCTION	PIN
1	AUDIO(-)	1
2	AUDIO(+)	9
3	GRD	2
4	GRD	10
5	FFSK TX	3
6	FFSK RX	11
7	CONF	4
8	VOLUME	12
9	GRD	5
10	ON/OFF	13
11	GLORST	6
12	GRD	14
13	SCL	7
14	SDA	15
15	(+)8V	8
16		---

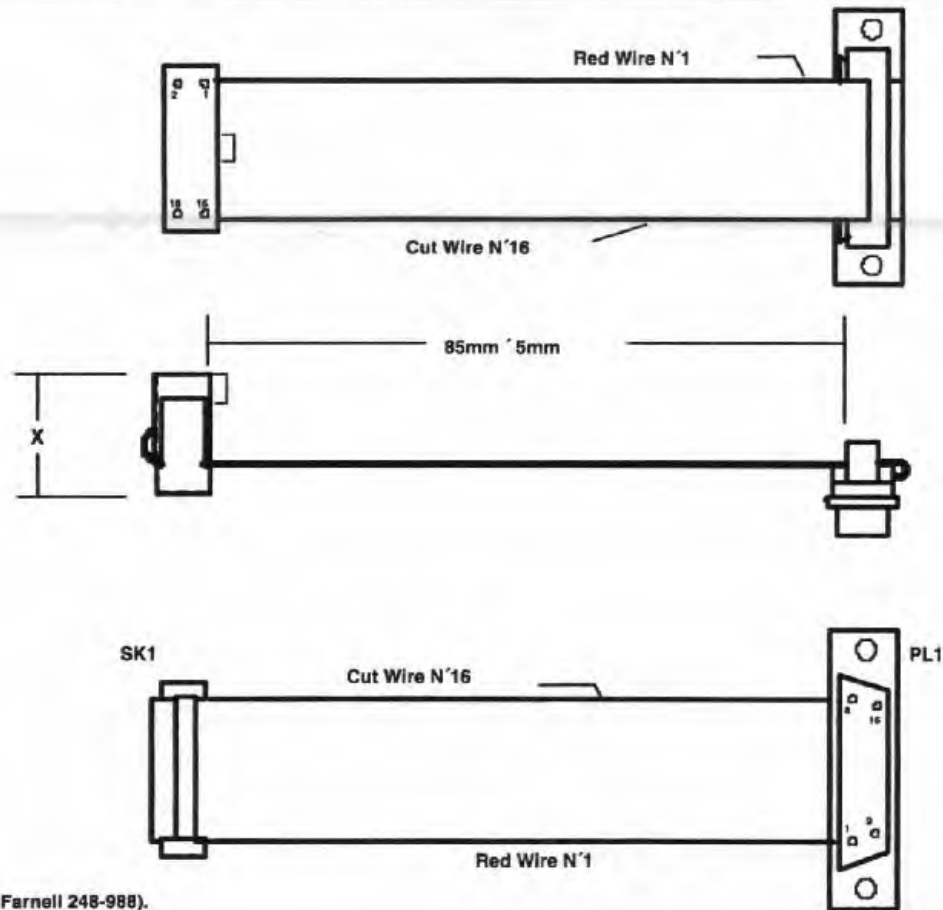

PL1 :- METAL D IDC PLUG 15-WAY TYPE CINCH FC15P (or equivalent).

SK1 :- BUMP-POLARISED IDC 16-WAY TYPE HARTING 09185166813 (or equivalent i.e. Farnell 248-988).

CABLE :- IDC RIBBON CABLE, GREY 0.05 PITCH (RED LEADING EDGE FOR WIRE N'1).

Note 1 :- Overall height of SK1 with strain-relief to not exceed 15.5mm max (dimension X).

Drawing Up-issue :- SK1 connector type changed/ Note 1 added/ Length corrected to original 85mm nom.

DRW:- 8LMT0006.L11	TITLE :- CONN RX LOOM. (Part L033RXLR1IX)	MAT :-	DRAWN :- B.PERRETT.
ISSUE :- 1.2		FIN :-	DATE :- 18.4.94.



PROJECTION :-

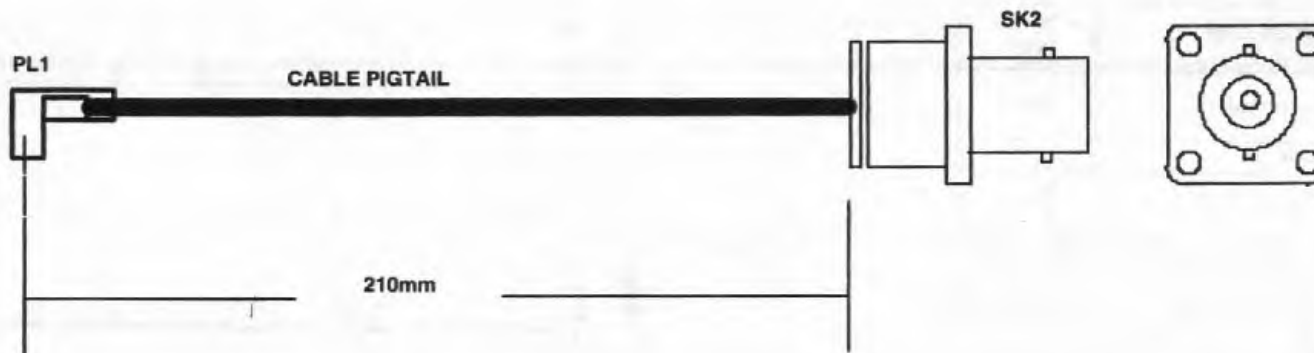
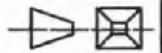

PL1/CABLE :- OMNI SPECTRA OSMT ANGLE JACK CABLE PIGTAIL 9950-2300-23 (or equivalent).

SK2 :- BNC/SK TYPE SUHNER 25 BNC 50-1-1C (or equivalent).

DRW:- 8LMT0006.L5I

TITLE :-

10MHz REF LOOM. (Part L033RXLR5IX)

MAT :-

DRAWN :- B.PERRETT.

ISSUE :- 1.0

FIN :-

DATE :- 18.4.94.



USA 220 Radio Frequency Unit Receiver

PCB Parts List

Document No: LM030401005

Issue 2.0

Reference	Description	Stock Number
C1	CAP 27pF NPO ±5% 0805	L06732705NGA0
C2	CAP 12pF NPO ±5% 0805	L06731205NGA0
C3	CAP 1nF X7R ±10% 0805	L0673102AXGA0
C4	CAP 1nF X7R ±10% 0805	L0673102AXGA0
C5	CAP 1nF X7R ±10% 0805	L0673102AXGA0
C6	CAP 10nF X7R ±10% 0805	L0673103AXGA0
C7	CAP 10pF NPO ±5% 0805	L06731005NGA0
C8	CAP 0p68 NPO ±0.25p 0805	L067368YCNGA0
C9	CAP 12pF NPO ±5% 0805	L06731205NGA0
C10	CAP 0p68 NPO ±0.25p 0805	L067368YCNGA0
C11	CAP 15pF NPO ±5% 0805	L06731505NGA0
C12	CAP 47pF NPO ±5% 0805	L06734705NGA0
C13	CAP 27pF NPO ±5% 0805	L06732705NGA0
C14	CAP 27pF NPO ±5% 0805	L06732705NGA0
C17	CAP SM ELECT 1uF 50V 20%	L067B105BEGA0
C21	CAP SM ELEC 10uF 16V 20%	L067B106BECA0
C22	CAP 100nF X7R ±10% 1206	L0674104AXGA0
C23	CAP 22pF NPO ±5% 0805	L06732205NGA0
C24	CAP 22pF NPO ±5% 0805	L06732205NGA0
C25	CAP 56pF NPO ±5% 0805	L06735605NGA0
C27	CAP 22pF NPO ±5% 0805	L06732205NGA0
C29	CAP 33pF NPO ±5% 0805	L06733305NGA0
C30	CAP 100nF X7R ±10% 1206	L0674104AXGA0
C31	CAP 10nF X7R ±10% 0805	L0673103AXGA0
C32	CAP 100pF NPO ±5% 0805	L06731015NGA0
C33	CAP 120pF NPO ±5% 0805	L06731215NGA0
C34	CAP 10nF X7R ±10% 0805	L0673103AXGA0
C35	CAP 10nF X7R ±10% 0805	L0673103AXGA0
C36	CAP 10nF X7R ±10% 0805	L0673103AXGA0
C37	CAP 10nF X7R ±10% 0805	L0673103AXGA0
C38	CAP 10nF X7R ±10% 0805	L0673103AXGA0
C39	CAP 33pF NPO ±5% 0805	L06733305NGA0
C41	CAP 22pF NPO ±5% 0805	L06732205NGA0
C43	CAP 10nF X7R ±10% 0805	L0673103AXGA0
C44	CAP 10nF X7R ±10% 0805	L0673103AXGA0
C45	CAP SM ELEC 10uF 16V 20%	L067B106BECA0
C46	CAP 10nF X7R ±10% 0805	L0673103AXGA0
C47	CAP 100nF X7R ±10% 1206	L0674104AXGA0
C48	CAP 22pF NPO ±5% 0805	L06732205NGA0
C49	CAP 22pF NPO ±5% 0805	L06732205NGA0
C50	CAP 100nF X7R ±10% 1206	L0674104AXGA0
C52	CAP SM ELECT 1uF 50V 20%	L067B105BEGA0
C53	CAP 10nF X7R ±10% 0805	L0673103AXGA0
C55	CAP 10pF NPO ±5% 0805	L06731005NGA0
C56	CAP 33pF NPO ±5% 0805	L06733305NGA0
C57	CAP SM ELEC 10uF 16V 20%	L067B106BECA0



C58	CAP 100pF NPO ±5% 0805	L06731015NGA0
C59	CAP 15pF NPO ±5% 0805	L06731505NGA0
C60	CAP 100pF NPO ±5% 0805	L06731015NGA0
C63	CAP 1nF X7R ±10% 0805	L0673102AXGAC
C64	CAP 100pF NPO ±5% 0805	L06731015NGA0
C66	CAP 10nF X7R ±10% 0805	L0673103AXGAC
C67	CAP 100pF NPO ±5% 0805	L06731015NGA0
C68	CAP 10nF X7R ±10% 0805	L0673103AXGAC
C70	CAP 10nF X7R ±10% 0805	L0673103AXGAC
C71	CAP 10nF X7R ±10% 0805	L0673103AXGAC
C72	1n SM NPO 1206 50V 5%	L06741025NGA0
C73	CAP 100pF NPO ±5% 0805	L06731015NGA0
C74	CAP 10nF X7R ±10% 0805	L0673103AXGAC
C75	180n SM X7R 1206 25V 10%	L0674184AXEAO
C77	CAP 100nF X7R ±10% 1206	L0674104AXGAC
C121	CAP 10nF X7R ±10% 0805	L0673103AXGAC
C122	CAP 100nF X7R ±10% 1206	L0674104AXGAC
C123	CAP SM ELECT 1uF 50V 20%	L067B105BEGA0
C124	CAP 10nF X7R ±10% 0805	L0673103AXGAC
C291	CAP 1nF X7R ±10% 0805	L0673102AXGAC
C293	CAP 1nF X7R ±10% 0805	L0673102AXGAC
C304	CAP 1nF X7R ±10% 0805	L0673102AXGAC
C305	CAP 1nF X7R ±10% 0805	L0673102AXGAC
C308	CAP SM ELECT 1uF 50V 20%	L067B105BEGA0
C309	CAP 100nF X7R ±10% 1206	L0674104AXGAC
C312	CAP 100pF NPO ±5% 0805	L06731015NGA0
C313	CAP 100pF NPO ±5% 0805	L06731015NGA0
C314	CAP 100pF NPO ±5% 0805	L06731015NGA0
C315	CAP 100pF NPO ±5% 0805	L06731015NGA0
C316	CAP 100pF NPO ±5% 0805	L06731015NGA0
C317	CAP 100pF NPO ±5% 0805	L06731015NGA0
C318	CAP 1nF X7R ±10% 0805	L0673102AXGAC
C319	CAP 1nF X7R ±10% 0805	L0673102AXGAC
C322	CAP 100nF X7R ±10% 1206	L0674104AXGAC
C323	CAP 1nF X7R ±10% 0805	L0673102AXGAC
C347	120n SM X7R 1206 25V 10%	L0674124AXEAO
C348	CAP 1nF X7R ±10% 0805	L0673102AXGAC
C349	CAP 100nF X7R ±10% 1206	L0674104AXGAC
C350	36p SM NPO 0805 50V 5%	L06733605NGA0
C351	36p SM NPO 0805 50V 5%	L06733605NGA0
C353	CAP 3p3 ±0.25p 0805	L067333ZCNGA0
C354	CAP 100nF X7R ±10% 1206	L0674104AXGAC
C355	CAP 1nF X7R ±10% 0805	L0673102AXGAC
C356	CAP 100pF NPO ±5% 0805	L06731015NGA0
C357	CAP 150nF POLYESTER	L06691540PFA0
D3	HSMP 3800 [SOT-23]	L063SHP3800A0
D4	HSMP 3800 [SOT-23]	L063SHP3800A0
D5	HSMP 3800 [SOT-23]	L063SHP3800A0
D6	HSMP 3800 [SOT-23]	L063SHP3800A0
D7	HSMP 3800 [SOT-23]	L063SHP3800A0
D8	BB515 [SOD-123]	L063SBB515XA0
D24	HSMP 3800 [SOT-23]	L063SHP3800A0
D25	HSMP 3800 [SOT-23]	L063SHP3800A0
D26	HSMP 3800 [SOT-23]	L063SHP3800A0
D28	BB515 [SOD-123]	L063SBB515XA0
F1	CRYSTAL FILT 45.0125MHz	L055MS03011A0
F2	CRYSTAL FILT 45.0125MHz	L055MS03011A0
H1	RFU SCREENING CAN NO.1	L004RFUSCN1A0
IC1	78L08 [SO-8]	L05778LC8SXA0
IC2	LMC660AIM [SO-14]	L057LMC660MA0
IC3	SA612A MIXER [SO-8]	L057SSA612AA0
IC4	78L05 [SO-8]	L05778L05SXA0
IC5	MB1504 [SO-16]	L057MB1504SA0



IC6	BA15532F [SO-8]	L057S5532XXA0
IC7	UPB587G [SO-8]	L057UPB587GA0
IC8	74HCT00 [SO-14]	L057HCT00SXAO
IC9	74HCT04 [SO-14]	L057HCT04SXAO
IC11	74HC373 SO-20W	L057HC373SXAO
IC12	78L05 [SO-8]	L05778L05SXAO
IC43	78L15 [SO-8]	L05778L15SXAO
L1	35nH TUNEABLE IND	L06493530LXA0
L2	35nH TUNEABLE IND	L06493530LXA0
L3	35nH TUNEABLE IND	L06493530LXA0
L4	35nH TUNEABLE IND	L06493530LXA0
L5	IND 68nH 10% 1008	L06486830CXA0
L6	IND 100nH 10% [1008]	L06481040CXA0
L8	IND 390nH 10% [1008]	L06483940CXA0
L9	IND 220nH 10% [1008]	L06482240CXA0
L10	IND 390nH 10% [1008]	L06483940CXA0
L12	145nH TUNEABLE IND	L06491445LXA0
L13	IND 1uH 10% [1008]	L06481050CXA0
L53	180n SM CHIP 1008 10%	L0649183ACXA0
L56	IND 100nH 10% [1008]	L06481040CXA0
MX1	TUF-1 FREQUENCY MIXER	L057TUF-1XXA0
PCB1	RFU PCB	L001RFUPCBXB0
PL5	50_ SUB MIN COAX CON SM	L013OSMTPCBA0
PL8	50_ SUB MIN COAX CON SM	L013OSMTPCBA0
PL10	3 X 1 TERMINAL STRIP	L01303X1TSXA0
PL11	3 X 1 TERMINAL STRIP	L01303X1TSXA0
PL12	6 X 1 TERMINAL STRIP	L01306X1TSXA0
R1	RES 4K7 0.1W ±2% 0805	L07134722POA0
R2	RES 100K 0.1W ±2% 0805	L07131042POA0
R3	RES 150K 0.1W ±2% 0805	L07131542POA0
R4	RES 10R 0.1W ±2% 0805	L07131002POA0
R5	RES 0R0 0.1W 0805	L07130022POA0
R7	RES 0R0 0.1W 0805	L07130022POA0
R8	RES 39K 0.1W ±2% 0805	L07133932POA0
R9	RES 10K 0.1W ±2% 0805	L07131032POA0
R10	RES 2K2 0.1W ±2% 0805	L07132222POA0
R11	RES 10K 0.1W ±2% 0805	L07131032POA0
R17	RES 39K 0.1W ±2% 0805	L07133932POA0
R18	RES 10K 0.1W ±2% 0805	L07131032POA0
R22	RES 2K2 0.1W ±2% 0805	L07132222POA0
R23	RES 10K 0.1W ±2% 0805	L07131032POA0
R24	RES 10R 0.1W ±2% 0805	L07131002POA0
R25	RES 120R 0.1W ±2% 0805	L07131212POA0
R26	RES 10R 0.1W ±2% 0805	L07131002POA0
R27	RES 51R 0.1W ±2% 0805	L07135102POA0
R28	RES 100K 0.1W ±2% 0805	L07131042POA0
R29	RES 10K 0.1W ±2% 0805	L07131032POA0
R30	RES 3K3 0.1W ±2% 0805	L07133322POA0
R31	RES 220K 0.1W ±2% 0805	L07132242POA0
R32	RES 330R 0.1W ±2% 0805	L07133312POA0
R33	RES 1K 0.1W ±2% 0805	L07131022POA0
R34	RES 100K 0.1W ±2% 0805	L07131042POA0
R35	RES 150K 0.1W ±2% 0805	L07131542POA0
R36	RES 330R 0.1W ±2% 0805	L07133312POA0
R37	RES 10K 0.1W ±2% 0805	L07131032POA0
R38	RES 3K3 0.1W ±2% 0805	L07133322POA0
R39	RES 150R 0.1W ±2% 0805	L07131512POA0
R40	RES 10R 0.1W ±2% 0805	L07131002POA0
R41	RES 470R 0.1W ±2% 0805	L07134712POA0
R42	RES 2K7 0.1W ±2% 0805	L07132722POA0
R43	RES 33R 0.1W ±2% 0805	L07133302POA0
R44	RES 1K 0.1W ±2% 0805	L07131022POA0
R45	RES 470R 0.1W ±2% 0805	L07134712POA0



R46	RES 2K7 0.1W ±2% 0805	L07132722P0A0
R47	RES 33R 0.1W ±2% 0805	L07133302P0A0
R48	RES 1K 0.1W ±2% 0805	L07131022P0A0
R49	RES 470R 0.1W ±2% 0805	L07134712P0A0
R50	RES 2K7 0.1W ±2% 0805	L07132722P0A0
R51	RES 33R 0.1W ±2% 0805	L07133302P0A0
R52	RES 1K5 0.1W ±2% 0805	L07131522P0A0
R53	RES 100K 0.1W ±2% 0805	L07131042P0A0
R54	RES 47K 0.1W ±2% 0805	L07134732P0A0
R55	RES 15K 0.1W ±2% 0805	L07131532P0A0
R56	RES 10K 0.1W ±2% 0805	L07131032P0A0
R57	RES 10K 0.1W ±2% 0805	L07131032P0A0
R58	RES 330R 0.1W ±2% 0805	L07133312P0A0
R59	RES 330R 0.1W ±2% 0805	L07133312P0A0
R60	RES 10K 0.1W ±2% 0805	L07131032P0A0
R61	RES 10K 0.1W ±2% 0805	L07131032P0A0
R62	RES 470R 0.1W ±2% 0805	L07134712P0A0
R63	RES 10K 0.1W ±2% 0805	L07131032P0A0
R64	RES 4K7 0.1W ±2% 0805	L07134722P0A0
R65	RES 10K 0.1W ±2% 0805	L07131032P0A0
R66	RES 1K 0.1W ±2% 0805	L07131022P0A0
R67	RES 2K2 0.1W ±2% 0805	L07132222P0A0
R68	RES 4K7 0.1W ±2% 0805	L07134722P0A0
R69	RES 220R 0.1W ±2% 0805	L07132212P0A0
R70	RES 150R 0.1W ±2% 0805	L07131512P0A0
R73	RES 10K 0.1W ±2% 0805	L07131032P0A0
R74	RES 4K7 0.1W ±2% 0805	L07134722P0A0
R75	RES 10K 0.1W ±2% 0805	L07131032P0A0
R76	RES 10K 0.1W ±2% 0805	L07131032P0A0
R107	RES 10K 0.1W ±2% 0805	L07131032P0A0
R108	RES 4K7 0.1W ±2% 0805	L07134722P0A0
R109	RES 470R 0.1W ±2% 0805	L07134712P0A0
R110	RES 150R 0.1W ±2% 0805	L07131512P0A0
R319	RES 4K7 0.1W ±2% 0805	L07134722P0A0
R320	RES 18R 0.1W ±2% 0805	L07131802P0A0
R321	RES 3K9 0.1W ±2% 0805	L07133922P0A0
R322	RES 330R 0.1W ±2% 0805	L07133312P0A0
R323	RES 4K7 0.1W ±2% 0805	L07134722P0A0
R324	RES 18R 0.1W ±2% 0805	L07131802P0A0
R325	RES 270R 0.1W ±2% 0805	L07132712P0A0
R334	RES 1K 0.1W ±2% 0805	L07131022P0A0
R337	RES 390R 0.1W ±2% 0805	L07133912P0A0
R343	RES 0R0 0.1W 0805	L07130022P0A0
R344	20K SM PRESET	L0719203XT4A0
R353	RES 150R 0.1W ±2% 0805	L07131512P0A0
R354	RES 51R 0.1W ±2% 0805	L07135102P0A0
R358	RES 51R 0.1W ±2% 0805	L07135102P0A0
R359	RES 51R 0.1W ±2% 0805	L07135102P0A0
R360	RES 150R 0.1W ±2% 0805	L07131512P0A0
R361	RES 300R 0.1W ±2% 0805	L07133012P0A0
SK1	10 X 2 SOCKET STRIP	L01310X2SKTA0
SK2	7 X 2 SOCKET STRIP	L01307X2SKTA0
TR1	BF991 [SOT-143]	L060SBF991XA0
TR2	BC846A [SOT-23]	L060SBC846AA0
TR5	BC846A [SOT-23]	L060SBC846AA0
TR7	BC856A [SOT-23]	L060SBC856AA0
TR8	BFS17A [SOT-23]	L060SBFS17AA0
TR9	BFS17A [SOT-23]	L060SBFS17AA0
TR10	BFS17A [SOT-23]	L060SBFS17AA0
TR18	BFS17A [SOT-23]	L060SBFS17AA0
TR33	SST310 [SOT-23]	L060SSST310A0



USA 220 Synthesiser Receive

PCB Parts List

Document No: LM030401015

Issue 3.5

Reference	Description	Stock Number
C1	CAP SM ELECT 1uF 50V 20%	L067B105BEGA0
C2	CAP 100nF X7R ±10% 1206	L0674104AXGA0
C3	CAP SM ELECT 1uF 50V 20%	L067B105BEGA0
C4	CAP 100nF X7R ±10% 1206	L0674104AXGA0
C5	CAP SM ELEC 10uF 16V 20%	L067B106BECA0
C6	CAP 100pF NPO ±5% 0805	L06731015NGA0
C7	CAP 10nF X7R ±10% 0805	L0673103AXGA0
C8	CAP 4p7 NPC 0.1pF 0805	L067347ZDNXA0
C9	CAP 3p3 NPC 0.1pF 0805	L067333ZDNXA0
C10	CAP 2p2 NPO ±0.25p 0805	L067322ZCNGA0
C12	CAP 100pF NPO ±5% 0805	L06731015NGA0
C14	CAP 100pF NPO ±5% 0805	L06731015NGA0
C15	CAP 100pF NPO ±5% 0805	L06731015NGA0
C16	CAP 1nF X7R ±10% 0805	L0673102AXGA0
C17	CAP 1nF X7R ±10% 0805	L0673102AXGA0
C18	CAP 1nF X7R ±10% 0805	L0673102AXGA0
C19	CAP 22pF NPC ±5% 0805	L067322Z05NGA0
C22	CAP 1nF X7R ±10% 0805	L0673102AXGA0
C23	CAP 1nF X7R ±10% 0805	L0673102AXGA0
C24	CAP 18pF NPO ±5% 0805	L06731805NGA0
C25	CAP 18pF NPO ±5% 0805	L06731805NGA0
C26	CAP 100pF NPO ±5% 0805	L06731015NGA0
C27	CAP 1nF X7R ±10% 0805	L0673102AXGA0
C28	CAP 330pF NPO ±5% 0805	L06733315NGA0
C29	CAP 10nF X7R ±10% 0805	L0673103AXGA0
C30	CAP SM ELEC 10uF 16V 20%	L067B106BECA0
C31	CAP 10nF X7R ±10% 0805	L0673103AXGA0
C33	CAP 1nF X7R ±10% 0805	L0673102AXGA0
C34	CAP 100nF X7R ±10% 1206	L0674104AXGA0
C35	CAP 100nF X7R ±10% 1206	L0674104AXGA0
C36	CAP 10nF X7R ±10% 0805	L0673103AXGA0
C37	CAP SM ELEC 10uF 16V 20%	L067B106BECA0
C38	CAP 100pF NPO ±5% 0805	L06731015NGA0
C39	CAP 100pF NPO ±5% 0805	L06731015NGA0
C40	CAP 1nF X7R ±10% 0805	L0673102AXGA0
C41	CAP 1nF NPO 5% 0805	L06731025NGA0
D1	BB515 [SOD-123]	L063SBB515XA0
H1	SYNTE SCREENING CAN NO.1	L004SYNSCN1A0
IC1	78L05 [SO-8]	L05778L05SXA0
IC2	78L05 [SO-8]	L05778L05SXA0
IC3	UPB587G [SO-8]	L057UPB587GA0
IC4	SP8715 [MP8]	L057SP8715SA0
IC5	NJ88C28 IG NPAS [NP20]	L057S88C28SA0
IC6	BA15532F [SO-8]	L057S5532XXA0
L2	IND 56nH 10% [1008]	L06485630CXA0
L3	IND 56nH 10% [1008]	L06485630CXA0



L4	IND 1uH 10% [1008]	L06481050CXA0
PCB1	PCB SYNTHESISER	L001SYNPCBXC0
R1	RES 270R 0.1W 2% 0805	L07132712P0A0
R2	RES 18R 0.1W ±2% 0805	L07131802P0A0
R3	RES 8K2 0.1W ±2% 0805	L07138222P0A0
R4	RES 51R 0.1W ±2% 0805	L07135102P0A0
R5	RES 10K 0.1W ±2% 0805	L07131032P0A0
R6	RES 10K 0.1W ±2% 0805	L07131032P0A0
R7	RES 4K7 0.1W ±2% 0805	L07134722P0A0
R8	RES 220R 0.1W ±2% 0805	L07132212P0A0
R9	RES 51R 0.1W ±2% 0805	L07135102P0A0
R15	RES 1K 0.1W ±2% 0805	L07131022P0A0
R16	RES 4K7 0.1W ±2% 0805	L07134722P0A0
R17	RES 10K 0.1W ±2% 0805	L07131032P0A0
R18	RES 150R 0.1W ±2% 0805	L07131512P0A0
R19	RES 10R 0.1W ±2% 0805	L07131002P0A0
R20	RES 22K 0.1W ±2% 0805	L07132232P0A0
R21	RES 330K 0.1W 2% 0805	L07133342P0A0
R22	RES 2K2 0.1W ±2% 0805	L07132222P0A0
R23	RES 10K 0.1W ±2% 0805	L07131032P0A0
R24	RES 10K 0.1W ±2% 0805	L07131032P0A0
R25	RES 10K 0.1W ±2% 0805	L07131032P0A0
R26	RES 10K 0.1W ±2% 0805	L07131032P0A0
R27	RES 10R 0.1W ±2% 0805	L07131002P0A0
R29	RES 1K 0.1W ±2% 0805	L07131022P0A0
R30	RES 100R 0.1W ±2% 0805	L07131012P0A0
R32	RES 0R0 0.1W 0805	L071300Z2P0A0
R34	RES 0R0 0.1W 0805	L071300Z2P0A0
SK1	025 MINI SPRING SOCKET	L013025CCXXA0
SK2	025 MINI SPRING SOCKET	L013025CCXXA0
SK3	025 MINI SPRING SOCKET	L013025CCXXA0
SK4	025 MINI SPRING SOCKET	L013025CCXXA0
SK5	025 MINI SPRING SOCKET	L013025CCXXA0
SK6	025 MINI SPRING SOCKET	L013025CCXXA0
SK7	025 MINI SPRING SOCKET	L013025CCXXA0
SK8	025 MINI SPRING SOCKET	L013025CCXXA0
SK9	025 MINI SPRING SOCKET	L013025CCXXA0
SK10	025 MINI SPRING SOCKET	L013025CCXXA0
SK11	025 MINI SPRING SOCKET	L013025CCXXA0
SK12	025 MINI SPRING SOCKET	L013025CCXXA0
TL1	800MHz RESONATOR (SM)	L055RES800AA0
TR1	BFR92A [SOT 23]	L060SBFR92AA0
TR2	BFR92A [SOT 23]	L060SBFR92AA0



USA 220 Signal Processing Unit Receiver

Software Parts List

Document No: LM030501002

Issue 1.0

Reference	Description	Stock Number
U23	S/W SPU RECEIVER U23 LOW	L058SPURU23A0
U24	S/W SPU RECEIVR U24 HIGH	L058SPURU24A0

PCB Parts List

Document No: LM030400002

Issue 1.2

Reference	Description	Stock Number
C2	CAP 47pF NPO 5% 0805	L06734705NBA0
C3	CAP 100n 2F4 / X7R 0805	L0673104A2BA0
C4	CAP 100n 2F4 / X7R 0805	L0673104A2BA0
C5	CAP 100n 2F4 / X7R 0805	L0673104A2BA0
C6	CAP 100n 2F4 / X7R 0805	L0673104A2BA0
C7	CAP 100n 2F4 / X7R 0805	L0673104A2BA0
C8	CAP 100n 2F4 / X7R 0805	L0673104A2BA0
C9	CAP 100n 2F4 / X7R 0805	L0673104A2BA0
C10	CAP 100n 2F4 / X7R 0805	L0673104A2BA0
C11	CAP 100n 2F4 / X7R 0805	L0673104A2BA0
C12	CAP 100n 2F4 / X7R 0805	L0673104A2BA0
C13	CAP 100n 2F4 / X7R 0805	L0673104A2BA0
C14	CAP 100n 2F4 / X7R 0805	L0673104A2BA0
C15	CAP 100n 2F4 / X7R 0805	L0673104A2BA0
C16	CAP 100n 2F4 / X7R 0805	L0673104A2BA0
C17	CAP 100n 2F4 / X7R 0805	L0673104A2BA0
C18	CAP 100n 2F4 / X7R 0805	L0673104A2BA0
C19	CAP 100n 2F4 / X7R 0805	L0673104A2BA0
C20	CAP 100n 2F4 / X7R 0805	L0673104A2BA0
C21	CAP 100n 2F4 / X7R 0805	L0673104A2BA0
C22	CAP 100n 2F4 / X7R 0805	L0673104A2BA0
C24	CAP 10pF NPO ±10% 0805	L0673100ANBA0
C29	CAP 100nF X7R ±10% 0805	L0673104AXBA0
C30	CAP 3n3 X7R 10% 1206	L0674332AXBA0
C31	CAP 3n3 X7R 10% 1206	L0674332AXBA0
C36	CAP 220nF X7R 10% 1206	L0674224AXBA0
C37	CAP 220nF X7R 10% 1206	L0674224AXBA0
C38	CAP 10nF X7R ±10% 0805	L0673103AXBA0
C39	CAP 100nF X7R ±10% 0805	L0673104AXBA0
C40	CAP 100nF X7R ±10% 0805	L0673104AXBA0
C41	CAP 100nF X7R ±10% 0805	L0673104AXBA0
C42	CAP 100nF X7R ±10% 0805	L0673104AXBA0
C43	CAP SM ELEC 10uF 16V 20%	L067B106BECA0
C44	CAP SM ELEC 10uF 16V 20%	L067B106BECA0
C45	CAP 470nF 10% X7R 1812	L0677474AXBA0
C46	CAP 100nF X7R 10% 1206	L0674104AXBA0



C47	CAP SM ELECT 1uF 50V 20%	L067B105BEGA0
C48	CAP 100nF X7R ±10% 0805	L0673104AXBA0
C51	CAP 47pF X7R 10% 0805	L0673470AXBA0
C52	CAP 47pF X7R 10% 0805	L0673470AXBA0
C57	CAP 100pF NPO ±10% 0805	L0673101ANBA0
C58	CAP 100pF NPO ±10% 0805	L0673101ANBA0
C60	CAP 100pF NPO ±10% 0805	L0673101ANBA0
C62	CAP 100pF NPO ±10% 0805	L0673101ANBA0
C67	CAP 100nF X7R ±10% 0805	L0673104AXBA0
C72	CAP SM ELECT 1uF 50V 20%	L067B105BEGA0
C73	CAP SM ELECT 1uF 50V 20%	L067B105BEGA0
C78	CAP 100nF X7R ±10% 0805	L0673104AXBA0
C79	CAP 100pF NPO ±10% 0805	L0673101ANBA0
C80	CAP 100nF X7R ±10% 0805	L0673104AXBA0
C81	CAP 1nF X7R ±10% 0805	L0673102AXBA0
C84	CAP 100nF X7R ±10% 0805	L0673104AXBA0
C89	CAP SM ELEC 10uF 16V 20%	L067B106BECA0
C90	CAP ELECT 220uF 25V	L0660227BEEA0
C91	CAP SM ELECT 1uF 50V 20%	L067B105BEGA0
C93	CAP SM ELEC 10uF 16V 20%	L067B106BECA0
C94	CAP 2u2 10V 20% [SM]	L067B225BEBE0
C95	CAP 100nF X7R ±10% 0805	L0673104AXBA0
C100	CAP 47uF 25V 20% [SM]	L067D476BEEA0
C101	CAP 100nF X7R ±10% 1206	L0674104AXGA0
C102	CAP 1nF X7R ±10% 0805	L0673102AXBA0
C103	CAP ELECT 82uF 25V 20%	L066PL1E820A0
C104	CAP ELECT 82uF 25V 20%	L066PL1E820A0
C105	CAP 4n7 X7R ±10% 1206	L0674472AXBA0
C106	CAP ELECT 27uF 35V 20%	L066PL1V270A0
C107	CAP ELECT 27uF 35V 20%	L066PL1V270A0
C108	CAP 100nF X7R ±10% 0805	L0673104AXEA0
C109	CAP ELECT 120uF 16V 20%	L066PL1C121A0
C110	CAP ELECT 330uF 10V 20%	L066PL1A331A0
C111	CAP ELECT 180uF 10V 20%	L066PL1A181A0
C112	CAP 1nF X7R ±10% 0805	L0673102AXBA0
C113	CAP 1nF X7R ±10% 0805	L0673102AXBA0
C114	CAP 100nF X7R ±10% 0805	L0673104AXBA0
C115	CAP 10nF X7R ±10% 0805	L0673103AXBA0
C116	CAP ELECT 1200uF 25V 20%	L066PL1E122A0
C117	CAP ELECT 270uF 16V 20%	L066PL1C271A0
C118	CAP 100nF X7R ±10% 0805	L0673104AXBA0
C119	CAP ELECT 56uF 16V 20%	L066PL1C560A0
C120	CAP ELECT 56uF 16V 20%	L066PL1C560A0
C121	CAP ELECT 56uF 16V 20%	L066PL1C560A0
C122	CAP ELECT 56uF 16V 20%	L066PL1C560A0
C123	CAP 2n2 X7R ±10% 1206	L0674222AXHA0
C124	CAP 100nF X7R ±10% 0805	L0673104AXBA0
D4	BAS16 [SOT-23]	L063SBAS16XA0
D6	BYV27-100 [SOD-57]	L063LBYV27SA0
D7	BAS32 [SOD-80]	L063SBAS32XA0
D8	BAS32 [SOD-80]	L063SBAS32XA0
D9	BAS32 [SOD-80]	L063SBAS32XA0
D10	BZX84C12 [SOT-23]	L063SBZX84SA0
D11	DE5SC4M [SM DE5]	L063DE5SC4MA0
D12	BAS32 [SOD-80]	L063SBAS32XA0
D13	BYV27-100 [SOD-57]	L063LBYV27SA0
D14	BYV27-100 [SOD-57]	L063LBYV27SA0
D15	BYV27-100 [SOD-57]	L063LBYV27SA0
D16	LDP24A	L063LDP24AXA0
F1	FUSE 10A (SMD)	L07210ASMD1A0
J3	AVDEL AVSERT M2.5 X 5mm	L0131176555A0
J4	AVDEL AVSERT M2.5 X 9mm	L0131176590A0
L1	22uH INDUCTOR	L06420UHLXXA0



L2	22uH INDUCTOR	L06420UHLXXA0
L3	22uH INDUCTOR	L06420UHLXXA0
L4	22uH LOW ESR CHOKE	L06422UHSM2A0
L5	22uH LOW ESR CHOKE	L06422UHSM2A0
L6	22uH LOW ESR CHOKE	L06422UHSM2A0
L7	22uH LOW ESR CHOKE	L06422UHSM2A0
L8	22uH LOW ESR CHOKE	L06422UHSM2A0
PCB1	SPU PCB	L001SPUPCBXC0
PL1	10 X 2 SHROUDED T/S SLIM	L01310X2PHSA0
PL2	7 X 2 SHROUDED T/S SLIM	L01307X2PHSA0
PL3	4X1 FRICT'N LOCK PIN HDR	L0134X1FLSPA0
Q1	BC856A [SOT-23]	L060SBC856AA0
Q2	BUK555-100B TO220	L060LBUK555A0
Q3	BC846A [SOT-23]	L060SBC846AA0
Q4	BC807 [SOT-23]	L060SBC807XA0
R1	RES 1K 0.1W ±2% 0805	L07131022P0A0
R2	RES 1K 0.1W ±2% 0805	L07131022P0A0
R4	RES 10K 0.1W ±2% 0805	L07131032P0A0
R5	RES 10K 0.1W ±2% 0805	L07131032P0A0
R6	RES 1K 0.1W ±2% 0805	L07131022P0A0
R7	RES 1K 0.1W ±2% 0805	L07131022P0A0
R8	RES 1K 0.1W ±2% 0805	L07131022P0A0
R12	RES 620R 0.1W ±2% 0805	L07136212P0A0
R13	RES 10K 0.1W ±2% 0805	L07131032P0A0
R14	RES 10K 0.1W ±2% 0805	L07131032P0A0
R15	RES 10K 0.1W ±2% 0805	L07131032P0A0
R16	RES 1K 0.1W ±2% 0805	L07131022P0A0
R17	RES 1K 0.1W ±2% 0805	L07131022P0A0
R18	RES 1K 0.1W ±2% 0805	L07131022P0A0
R19	RES 1K 0.1W ±2% 0805	L07131022P0A0
R20	RES 51R 0.1W ±2% 0805	L07135102P0A0
R24	RES 470R 0.1W ±2% 0805	L07134712P0A0
R25	RES 1K5 0.1W ±2% 0805	L07131522P0A0
R26	RES 330R 0.1W ±2% 0805	L07133312P0A0
R27	RES 330R 0.1W ±2% 0805	L07133312P0A0
R32	RES 1K5 0.1W ±2% 0805	L07131522P0A0
R33	RES 1K5 0.1W ±2% 0805	L07131522P0A0
R34	RES 33R 0.1W ±2% 0805	L07133302P0A0
R35	RES 33R 0.1W ±2% 0805	L07133302P0A0
R36	RES 1K5 0.1W ±2% 0805	L07131522P0A0
R37	RES 100K 0.1W ±2% 0805	L07131042P0A0
R38	RES 100K 0.1W ±2% 0805	L07131042P0A0
R39	RES 10K 0.1W ±2% 0805	L07131032P0A0
R40	RES 10K 0.1W ±2% 0805	L07131032P0A0
R41	RES 10K 0.1W ±2% 0805	L07131032P0A0
R42	RES 10K 0.1W ±2% 0805	L07131032P0A0
R43	RES 10K 0.1W ±2% 0805	L07131032P0A0
R44	RES 10K 0.1W ±2% 0805	L07131032P0A0
R45	RES 620R 0.1W ±2% 0805	L07136212P0A0
R46	RES 10K 0.1W ±2% 0805	L07131032P0A0
R47	RES 10K 0.1W ±2% 0805	L07131032P0A0
R48	RES 10K 0.1W ±2% 0805	L07131032P0A0
R49	RES 10K 0.1W ±2% 0805	L07131032P0A0
R50	RES 10K 0.1W ±2% 0805	L07131032P0A0
R51	RES 10K 0.1W ±2% 0805	L07131032P0A0
R52	RES 10K 0.1W ±2% 0805	L07131032P0A0
R53	RES 10K 0.1W ±2% 0805	L07131032P0A0
R55	RES 15K 0.1W ±2% 0805	L07131532P0A0
R57	RES 10K 0.1W ±2% 0805	L07131032P0A0
R59	RES 82K 0.1W ±2% 0805	L07138232P0A0
R63	RES 300R 0.1W ±2% 0805	L07133012P0A0
R64	RES 300R 0.1W ±2% 0805	L07133012P0A0
R65	RES 10K 0.1W ±2% 0805	L07131032P0A0



R68	RES 3K6 0.1W ±2% 0805	L07133622P0A0
R70	RES 100K 0.1W ±2% 0805	L07131042P0A0
R71	RES 3R3 0.1W ±5% 0805	L071333Z5P0A0
R72	RES 120K 0.1W ±2% 0805	L07131242P0A0
R73	RES 1K8 0.1W ±2% 0805	L07131822P0A0
R74	RES 390K 0.1W ±2% 0805	L07133942P0A0
R76	RES 10K 0.1W ±2% 0805	L07131032P0A0
R77	RES 0R0 0.1W 0805	L071300Z2P0A0
R78	RES 10K 0.1W ±2% 0805	L07131032P0A0
R79	RES 82K 0.1W ±2% 0805	L07138232P0A0
R80	RES 12K 0.1W ±2% 0805	L07131232P0A0
R87	RES 33K 0.1W ±2% 0805	L07133332P0A0
R90	RES 0R0 0.1W 0805	L071300Z2P0A0
R91	RES 100K 0.1W ±2% 0805	L07131042P0A0
R93	RES 2M2 0.1W ±2% 0805	L07132252P0A0
R94	RES 1M0 0.1W ±2% 0805	L07131052P0A0
R95	RES 1M0 0.1W ±2% 0805	L07131052P0A0
R96	RES 1M0 0.1W ±2% 0805	L07131052P0A0
R97	RES 39K 0.1W ±2% 0805	L07133932P0A0
R98	RES 10K 0.1W ±2% 0805	L07131032P0A0
R99	RES 10K 0.1W ±2% 0805	L07131032P0A0
R106	RES 100K 0.1W ±2% 0805	L07131042P0A0
R107	RES 100K 0.1W ±2% 0805	L07131042P0A0
R108	RES 100K 0.1W ±2% 0805	L07131042P0A0
R109	RES 1K2 0.1W ±2% 0805	L07131222P0A0
R110	RES 270K 0.1W ±2% 0805	L07132742P0A0
R111	RES 150K 0.1W ±2% 0805	L07131542P0A0
R112	RES 150K 0.1W ±2% 0805	L07131542P0A0
R113	RES 10R 0.125W ±2% 1206	L07141002P4A0
R114	RES 100R 0.1W ±2% 0805	L07131012P0A0
R115	RES 3K9 0.1W ±2% 0805	L07133922P0A0
R116	RES 22K 0.1W ±2% 0805	L07132232P0A0
R117	RES 12R 0.125W ±2% 1206	L07141202P4A0
R118	RES 0R0 0.1W 0805	L071300Z2P0A0
R119	RES 15K 0.125W ±2% 1206	L07141532P4A0
R120	RES 10K 0.1W ±2% 0805	L07131032P0A0
R121	RES 22K 0.1W ±2% 0805	L07132232P0A0
R122	RES 1K0 0.125W ±1% 1206	L07141021P4A0
R123	RES 56K 0.1W ±2% 0805	L07135632P0A0
R124	RES 100K 0.1W ±2% 0805	L07131042P0A0
R125	RES 15K 0.1W ±2% 0805	L07131532P0A0
R126	RES 2K7 0.1W ±2% 0805	L07132722P0A0
R127	RES 27K 0.1W ±2% 0805	L07132732P0A0
R128	RES 22R 0.125W ±2% 1206	L07142202P8A0
R129	RES 1K0 0.125W ±1% 1206	L07141021P4A0
R130	RES 270R 0.425W ±5% 1210	L07152715PBA0
R131	RES 270R 0.425W ±5% 1210	L07152715PBA0
R132	RES 0R1 2.5W 10%	L069W210R1XA0
R133	RES 8K2 0.1W ±2% 0805	L07138222P0A0
R134	RES 68K 0.1W ±2% 0805	L07136832P0A0
R135	RES 2K2 0.125W ±2% 1206	L07142222P4A0
R136	RES 3K9 0.1W ±2% 0805	L07133922P0A0
R137	RES 330R 0.1W ±2% 0805	L07133312P0A0
R138	RES 3K9 0.1W ±2% 0805	L07133922P0A0
R140	RES 10K 0.1W ±2% 0805	L07131032P0A0
R154	RES 10K 0.1W ±2% 0805	L07131032P0A0
R157	RES 10K 0.1W ±2% 0805	L07131032P0A0
R160	RES 10K 0.1W ±2% 0805	L07131032P0A0
R162	RES 620R 0.1W ±2% 0805	L07136212P0A0
R163	RES 620R 0.1W ±2% 0805	L07136212P0A0
R164	RES 43K 0.1W ±2% 0805	L07134332P0A0
R170	RES 0R0 0.1W 0805	L071300Z2P0A0
R171	RES 0R0 0.1W 0805	L071300Z2P0A0



R172	RES 100K 0.1W ±2% 0805	L07131042P0A0
R173	RES 120K 0.1W ±2% 0805	L07131242P0A0
R174	RES 1K 0.1W ±2% 0805	L07131022P0A0
R175	RES 1K 0.1W ±2% 0805	L07131022P0A0
R176	RES 1K 0.1W ±2% 0805	L07131022P0A0
R177	RES 1K 0.1W ±2% 0805	L07131022P0A0
R178	RES 1K 0.1W ±2% 0805	L07131022P0A0
R179	RES 1K 0.1W ±2% 0805	L07131022P0A0
R180	RES 1K 0.1W ±2% 0805	L07131022P0A0
R181	RES 1K 0.1W ±2% 0805	L07131022P0A0
R182	RES 1K 0.1W ±2% 0805	L07131022P0A0
R183	RES 1K 0.1W ±2% 0805	L07131022P0A0
R184	RES 1K 0.1W ±2% 0805	L07131022P0A0
R185	RES 1K 0.1W ±2% 0805	L07131022P0A0
R186	RES 1K 0.1W ±2% 0805	L07131022P0A0
R189	RES 0R0 0.1W 0805	L071300Z2P0A0
R190	RES 15K 0.1W ±2% 0805	L07131532P0A0
SK1	8 X 2 SHROUDED T/STRIP	L01308X2PHSAC
SK2	8 X 2 PIN HEADER	L01308X2TSXAC
SK3	32 PIN PLCC EPROM SOCKET	L01332PLCCSAC
SK4	32 PIN PLCC EPROM SOCKET	L01332PLCCSAC
T1	EDF20 TRANSFORMER CUSTOM	L007ABTRAN8A0
U10	LMC660AIM [SO-14]	L057LMC660MA0
U12	TLC274ID [SO-14]	L057TLC274XA0
U13	TLC274ID [SO-14]	L057TLC274XA0
U14	TLC274ID [SO-14]	L057TLC274XA0
U16	TMS320C25FNA 68 PIN PLCC	L057320C25XA0
U17	EDI8834C35MI [28PIN SOJ]	L057ED34C35A0
U18	EDI8834C35MI [28PIN SOJ]	L057ED34C35A0
U19	74HCT273 [SO-20W]	L057HCT273TA0
U20	74HCT273 [SO-20W]	L057HCT273TA0
U21	SOFTWARE [PAL]	L05720V8H55A0
U22	<i>PLCC 54T</i> PCD8584T [SO-20W]	L057PCD8584A0
U25	39.32160MHZ OSC 4 PIN	L055X39M321A0
U26	74HCT273 [SO-20W]	L057HCT273TA0
U27	74HCT125 [SO-14]	L057HCT125SAC
U28	MAX699EWE [SO-16W]	L057MAX699EAC
U29	1020A FPGA [PLCC-68]	L057FPGABLVAC
U30	TDA1544SO [SO-16W]	L057TDA1544AC
U31	TDA1544SO [SO-16W]	L057TDA1544AC
U32	CS5349-BS [SO-28W]	L057CS5349BAC
U33	74HCT4053 [SO-16]	L057HCT4053AC
U34	TDA1013B 9 PIN SIL	L057TDA1013AC
U36	74HCT4053 [SO-16]	L057HCT4053AC
U37	SA577D [SO-14]	L057SA577DXA0
U38	4093 [SO-14]	L0574093BTXA0
U39	UC2845N [8-PIN DIL]	L057UC2845AA0
U40	78L05 [SO-8]	L05778L05SXA0



Radio Frequency Unit Receiver v4.3

Top View

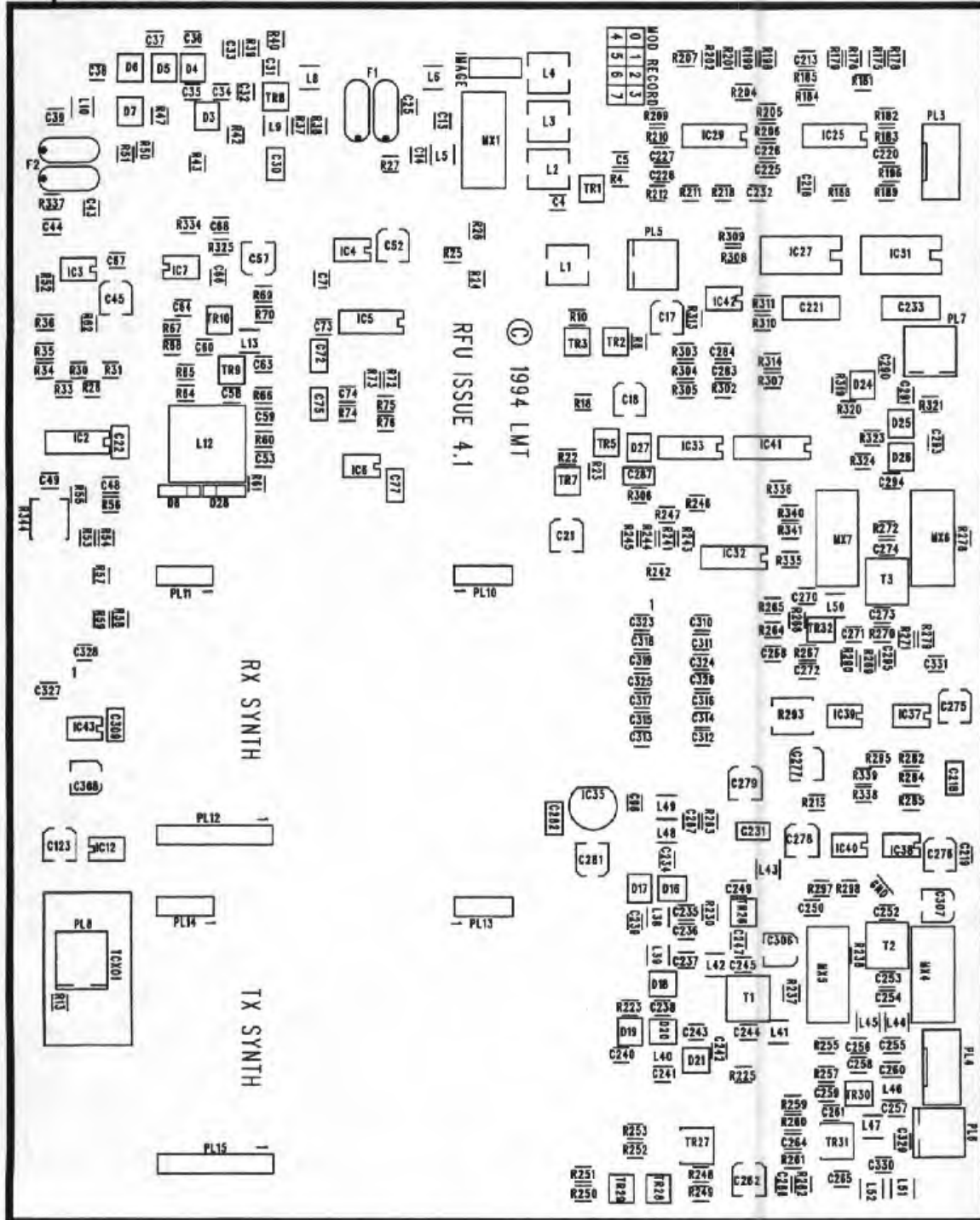

SECURICOR - LMT LTD
RFU BOARD ISSUE 4.1

Bottom View



MOTTOM SCREEN SILK
RFU BOARD ISSUE 4.1
SECURICOR - LMT LTD



Radio Frequency Unit Receiver v5.2

Top View

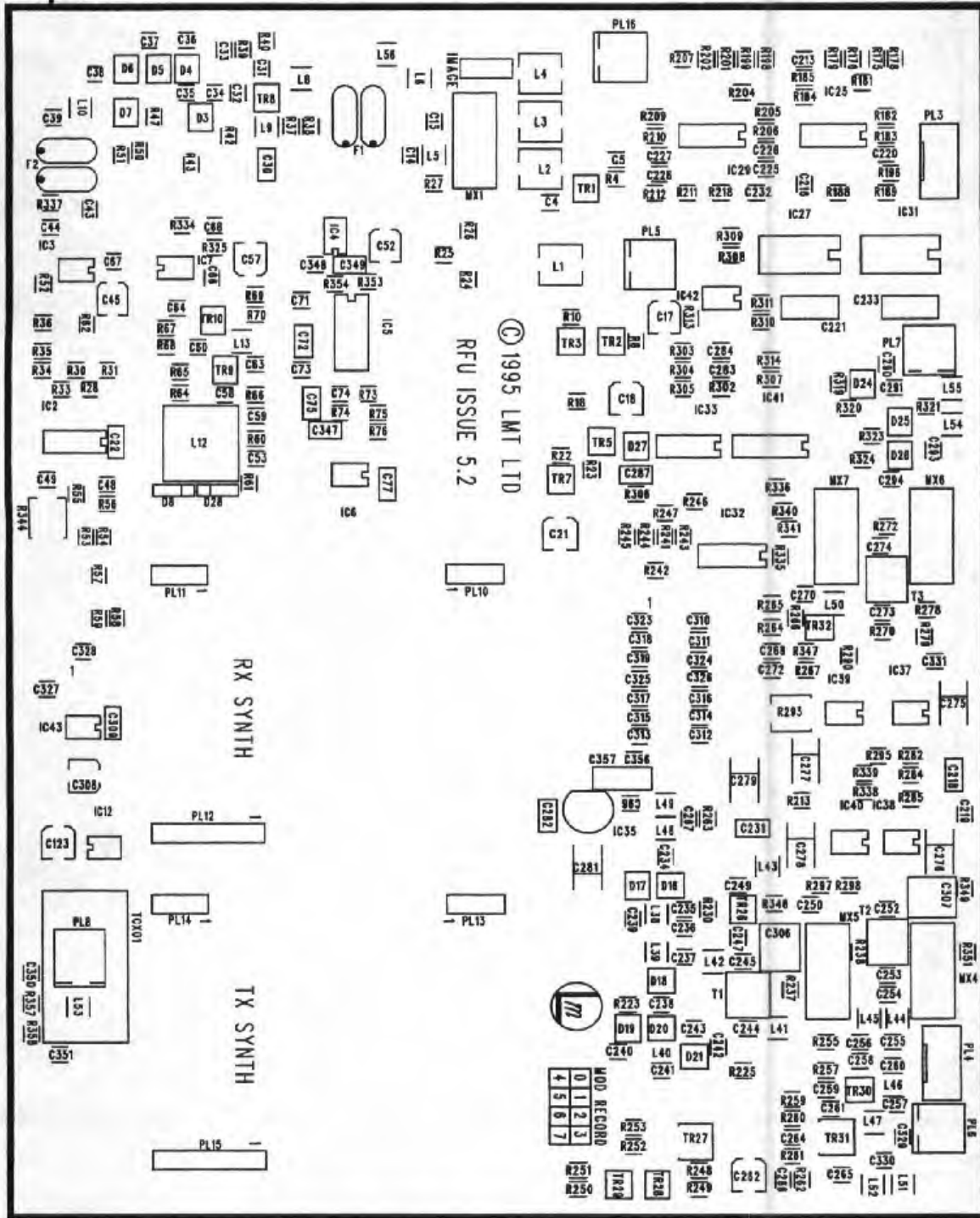

SECURICOR - LMT LTD
 RFU BOARD ISSUE 5.2
 SILK SCREEN TOP



Bottom View



MOTTON SILK SCREEN BOTTOM
RFU BOARD ISSUE 2.5
SECURICOR - LMT LTD



Synthesiser Receive

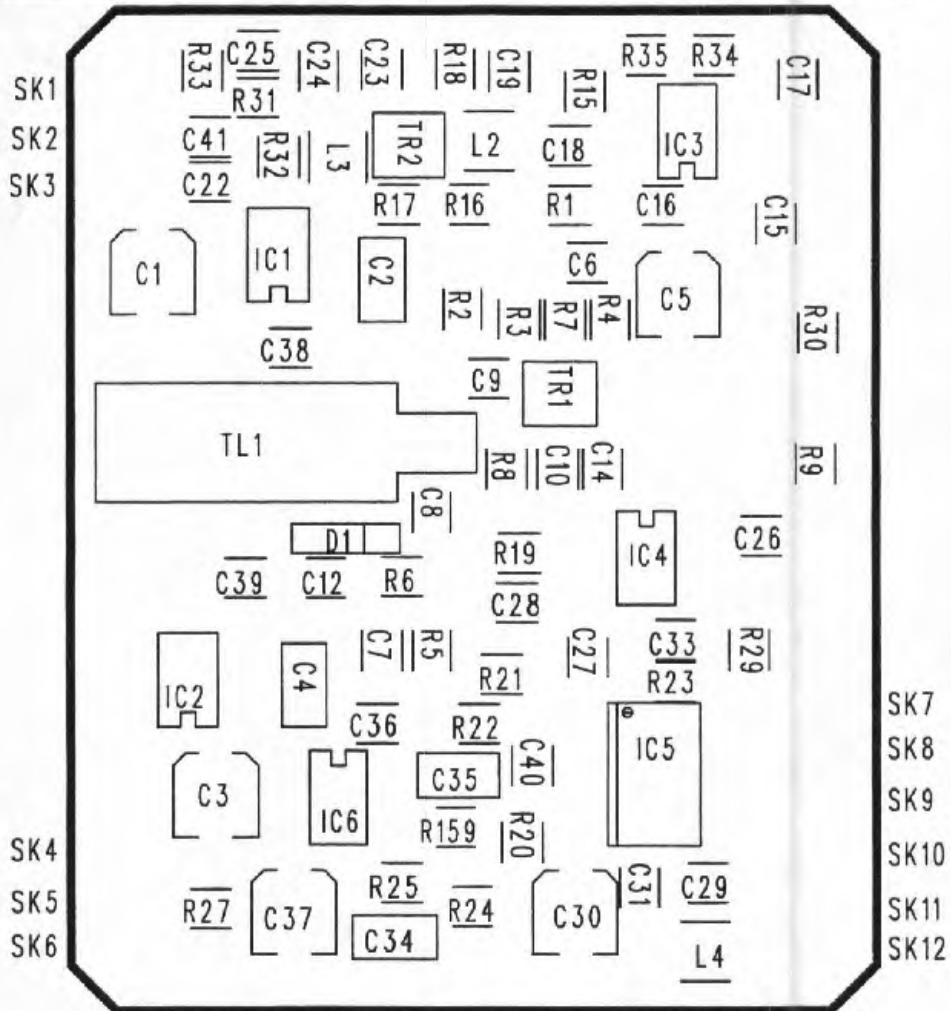

LINEAR MODULATION TECHNOLOGY
SYNTHESISER PCB VER 3.2



Signal Processing Unit Receiver

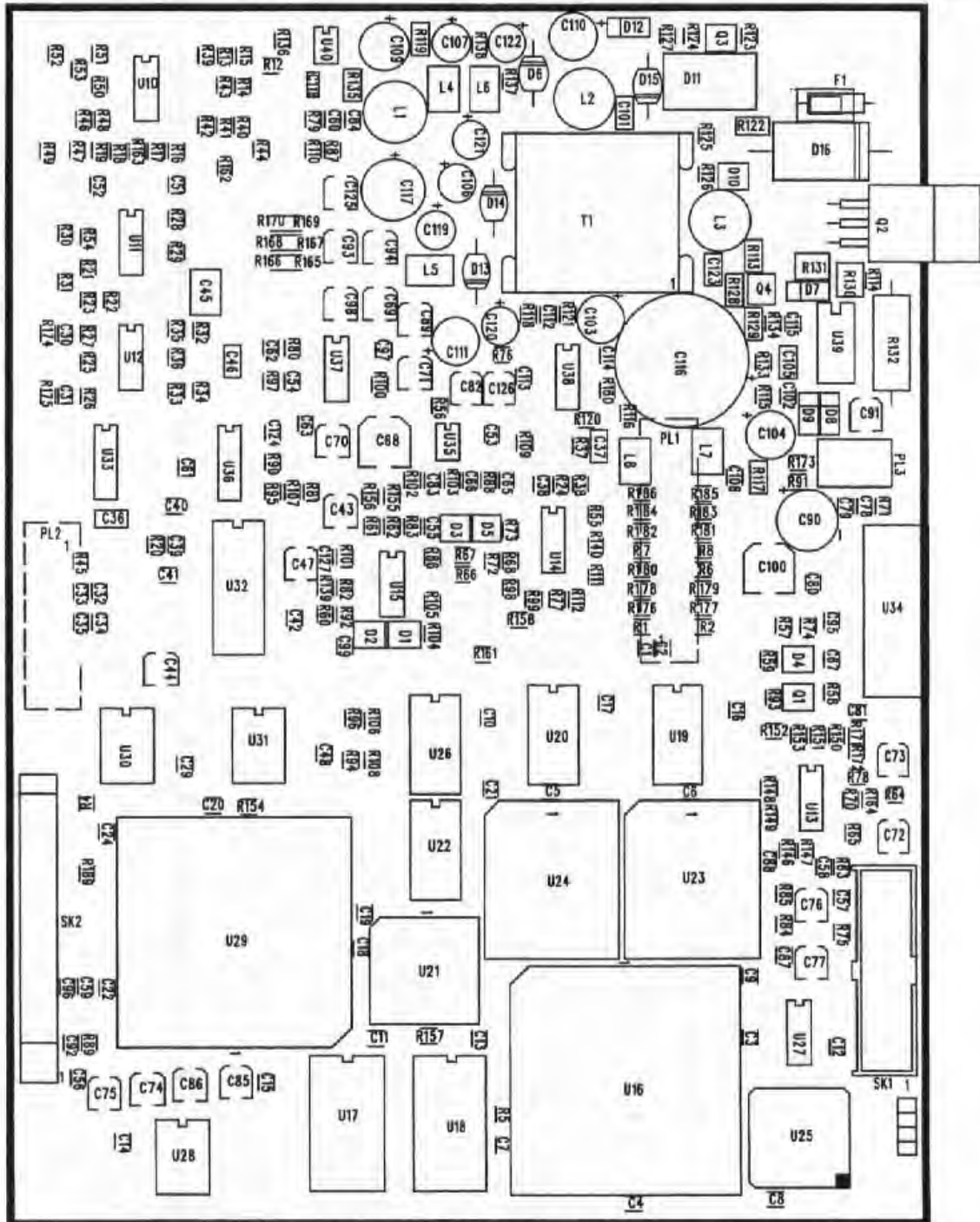

SECURICOR ELECTRONICS - LMT LTD
SPU BOARD ISSUE 2.5

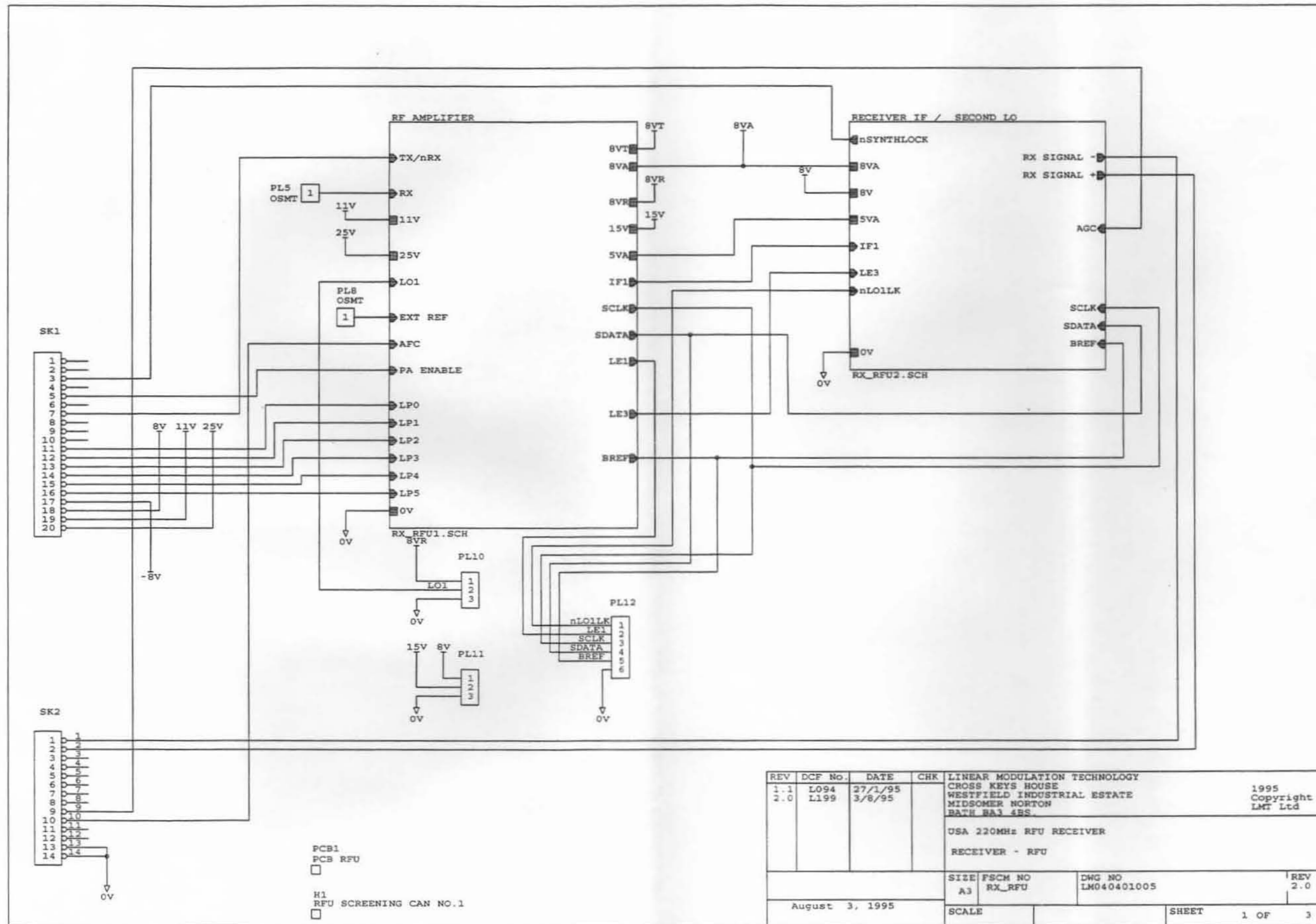

REV	DCF No.	DATE	CHK	LINEAR MODULATION TECHNOLOGY CROSS KEYS HOUSE WESTFIELD INDUSTRIAL ESTATE MIDSOMER NORTON BATH BA3 4BS.	1995 Copyright LMT Ltd
1.1	L094	27/1/95		USA 220MHz RFU RECEIVER RECEIVER - RFU	
2.0	L199	3/6/95			
				SIZE A3	FSCM NO RX_RFU
				DWG NO LM040401005	REV 2.0
August 3, 1995				SCALE	SHEET 1 OF 3

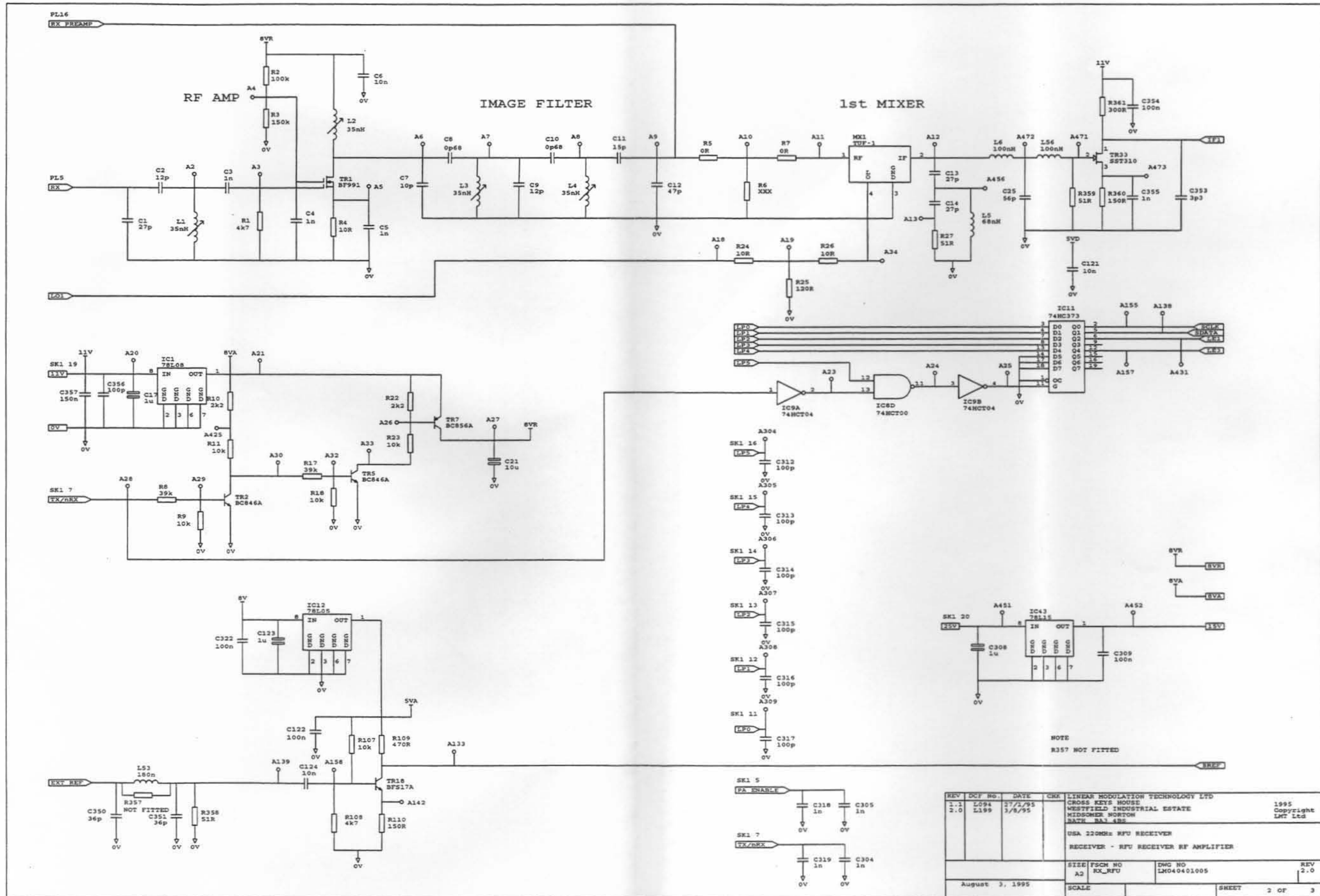

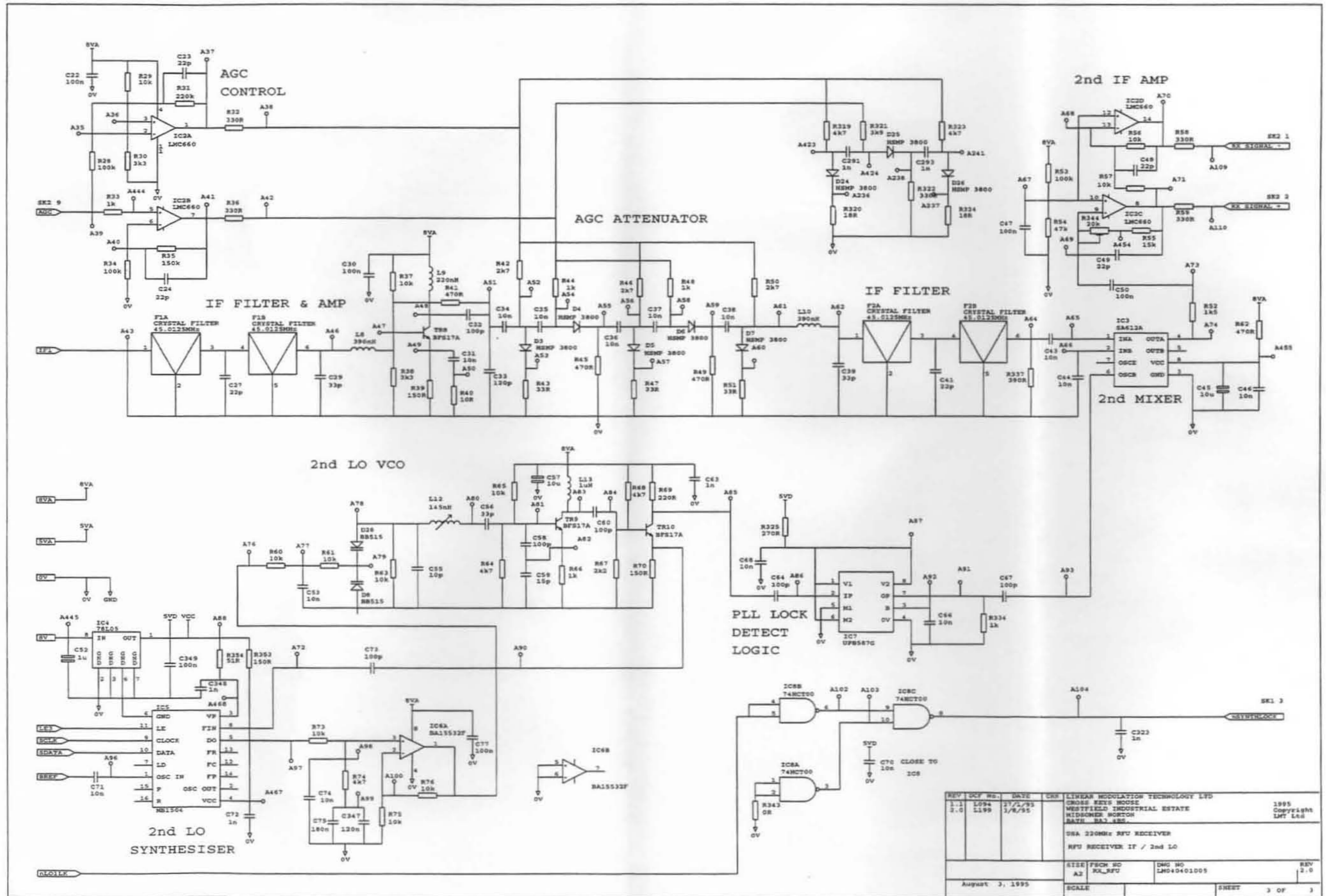

REV	DCF No.	DATE	CRF	LINEAR MODULATION TECHNOLOGY LTD	1995
1.1	L094	27/1/95		CROSS KEY HOUSE	COFFSHAM
2.0	L199	1/8/95		WESTFIELD INDUSTRIAL ESTATE	1MT L68
				WIDSMOR NORTH	
				BATH BA3 9SS	
USA 230MHz RFU RECEIVER					
RFU RECEIVER IF / 2nd LO					
REV 3.0			REV 3.0		
August 3, 1995			SCALE	DWG NO LNC401005	SHEET 3 OF 3

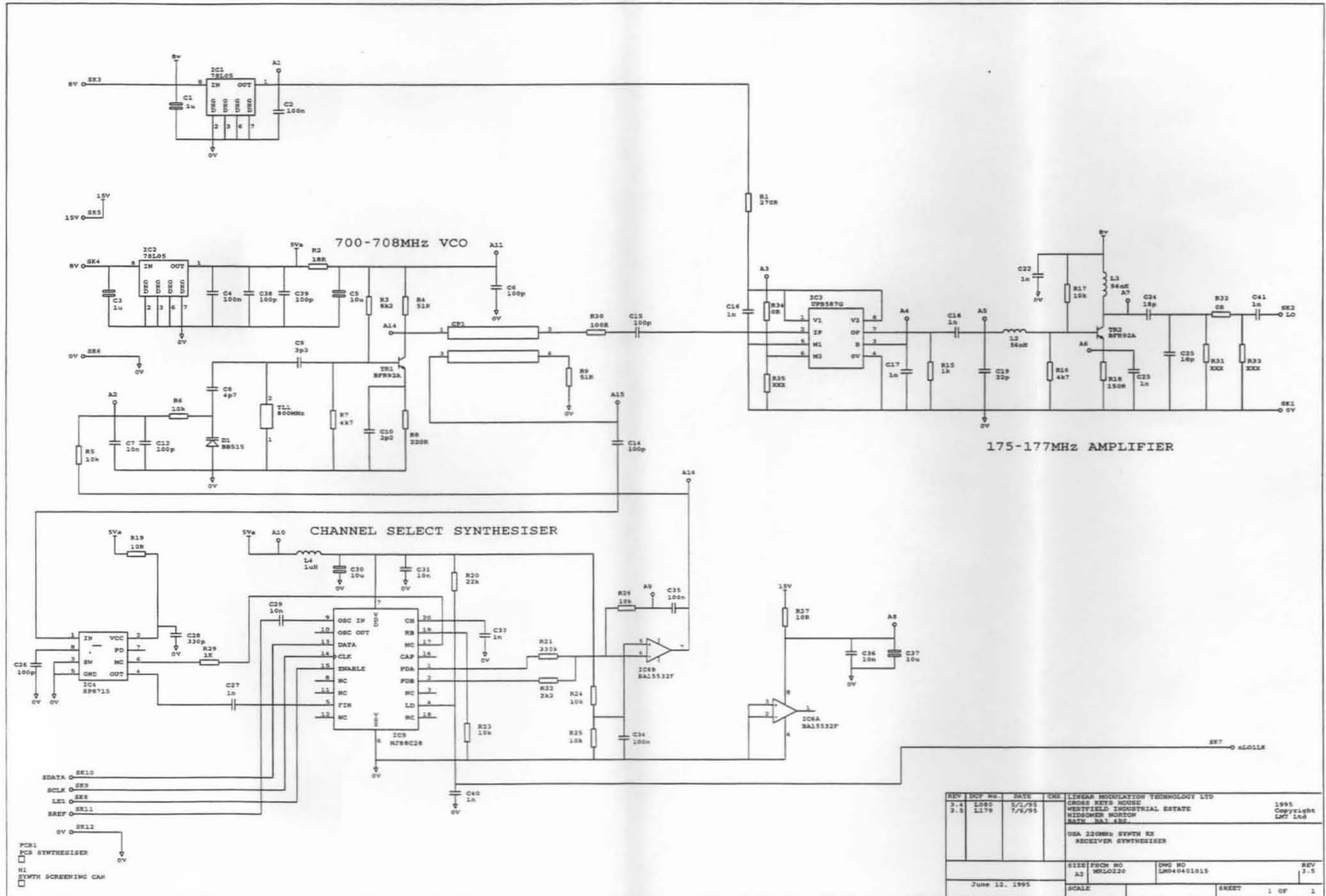

REV	DCP NO	DATE	CHK	LINEAR MODULATION TECHNOLOGY LTD CROSS KEY'S HOUSE WESTFIELD INDUSTRIAL ESTATE MIDDLESBORO SOUTH DAKOTA	1995 Copyright LMT Ltd
3.4	L080	5/1/95			
3.5	L179	7/4/95			
				USA 230MHz SYNTH RX RECEIVER SYNTHESISER	
				SIZE PCB NO A3 WPL0220	DWG NO LMD401015
June 12, 1995				SCALE	REV 3.5
				SHEET	1 OF 1



RX_SPU Top Level

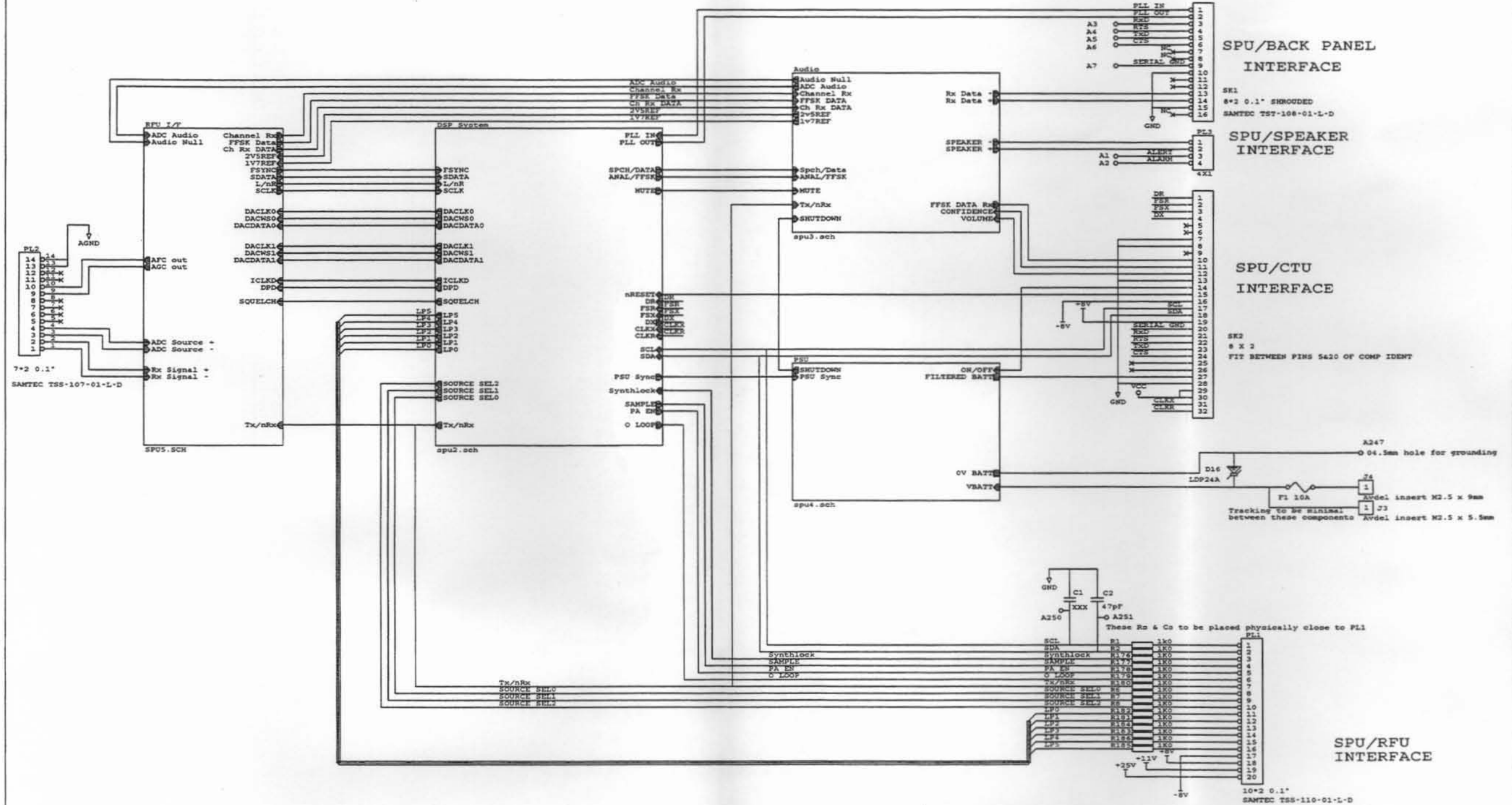

DRAWN BY C. MALKIN ISSUED ON DC 10150	Linear Modulation Technology Ltd Cross Keys House Westfield Industrial Estate Midsomer Norton Bath, BA1 4BS		
	BASE RECEIVER SPU		
June 5, 1995	SIZE PFCM NO A2 RX_SPU.SCH	DWG NO LMD40400002	REV 1.2
SCALE	SHEET 1 OF 6		

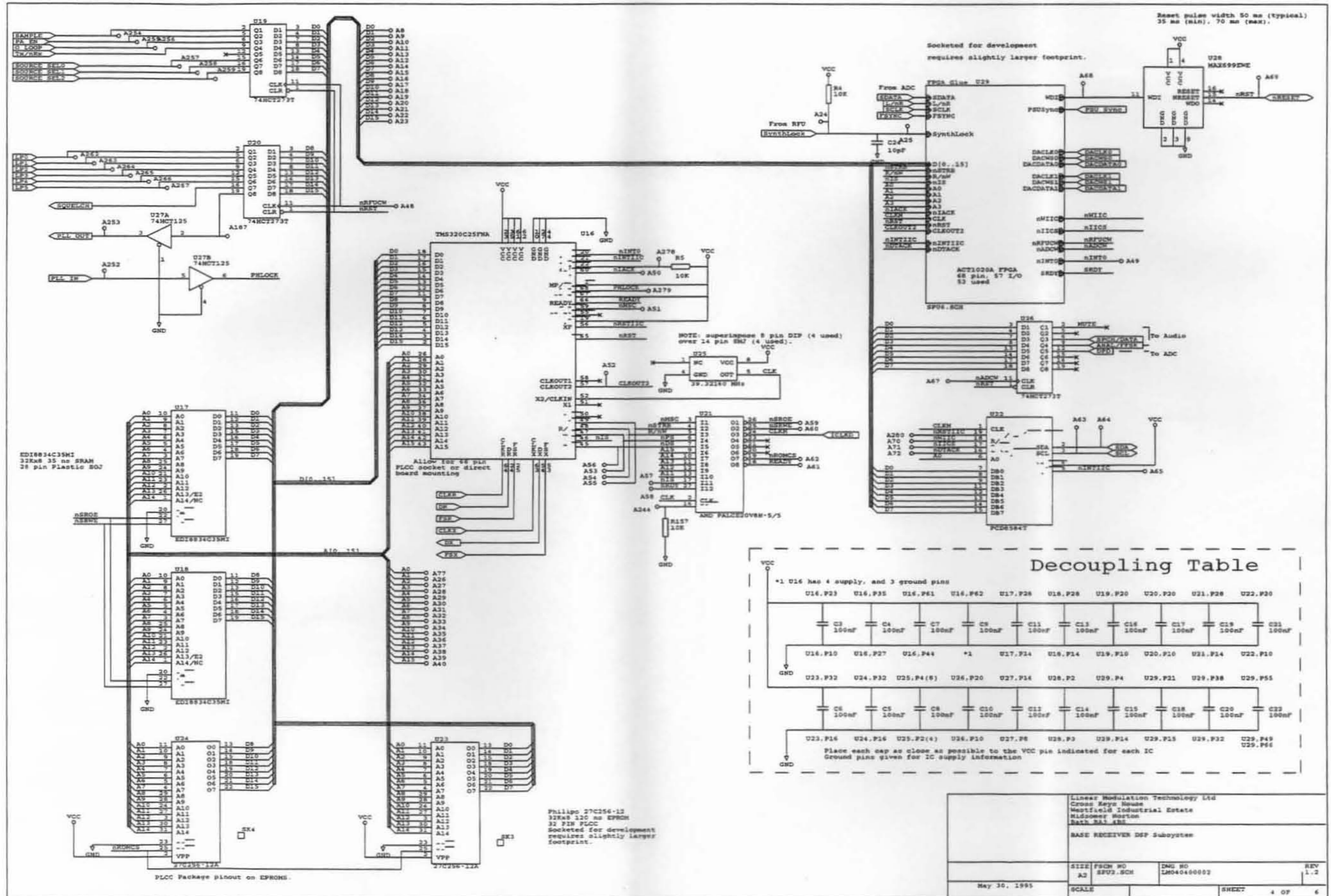

Decoupling Table

*1 U16 has 4 supply, and 3 ground pins

U16.P23	U16.P35	U16.P61	U16.P62	U17.P28	U18.P28	U19.P20	U20.P20	U21.P28	U22.P20
C3 100nF	C4 100nF	C7 100nF	C8 100nF	C11 100nF	C13 100nF	C16 100nF	C17 100nF	C19 100nF	C21 100nF
U16.P10	U16.P27	U16.P44	*1	U17.P14	U18.P14	U19.P10	U20.P10	U21.P14	U22.P10
U23.P32	U24.P32	U25.P4(8)	U26.P20	U27.P16	U28.P2	U29.P4	U29.P21	U29.P38	U29.P55
C6 100nF	C5 100nF	C8 100nF	C10 100nF	C12 100nF	C14 100nF	C15 100nF	C18 100nF	C20 100nF	C22 100nF
U23.P16	U24.P16	U25.P2(4)	U26.P10	U27.P8	U28.P3	U29.P14	U29.P15	U29.P32	U29.P49
Place each cap as close as possible to the VCC pin indicated for each IC Ground pins given for IC supply information									

Linear Modulation Technology Ltd
Cross Keys House
Westfield Industrial Estate
Middesmore Wotton
Bath BA1 1BE

BASE RECEIVER DSP Subsystem

SIZE	FSOH NO	DWG NO	REV
A3	SF03.SCH	LM04040002	1.2
May 30, 1995	SCALE	SHEET	4 OF 6

AUDIO

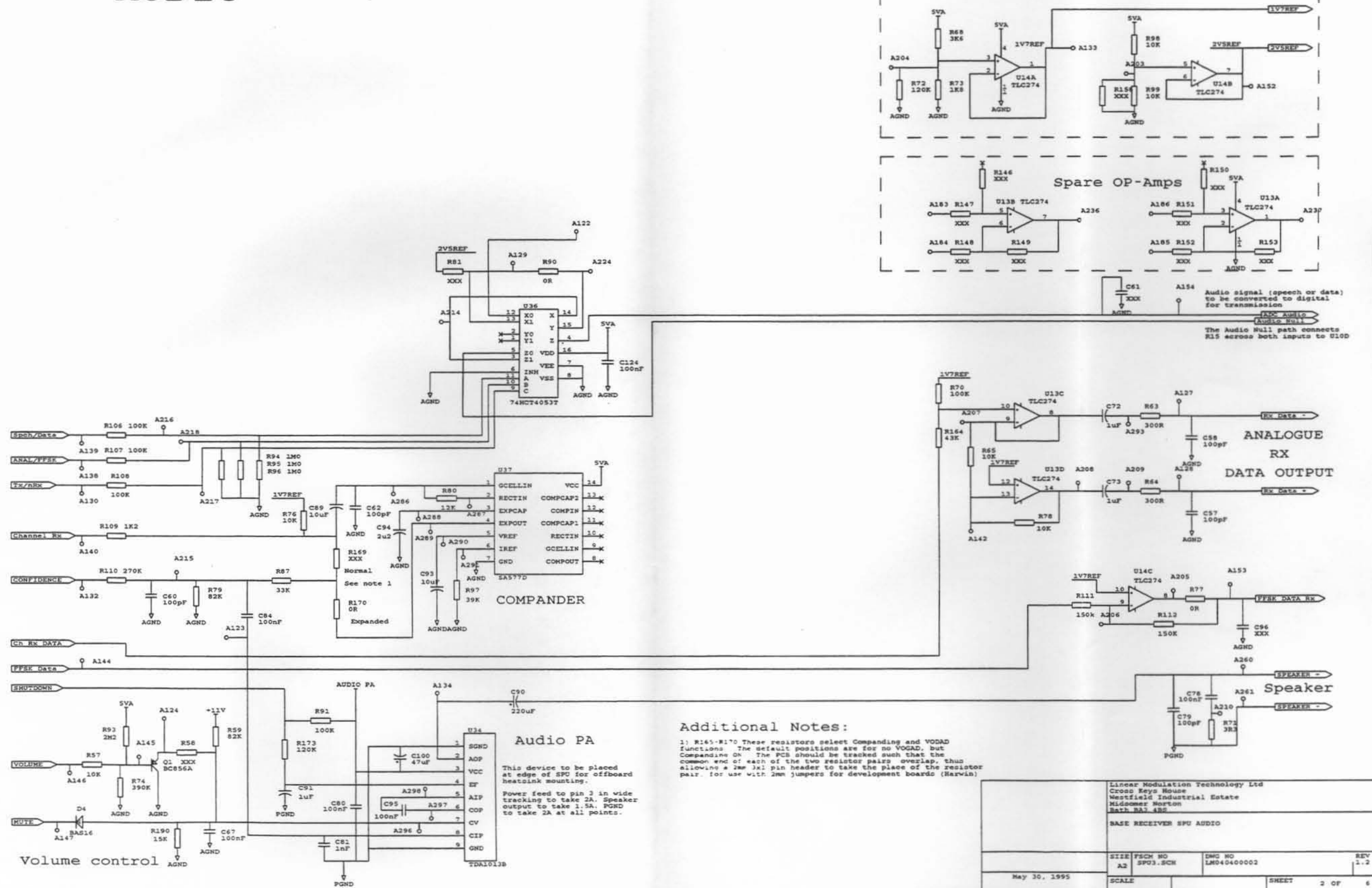

Additional Notes:

1) R165-R170 These resistors select Companding and VODAD functions. The default positions are for no VODAD, but Companding ON. The PCB should be tracked such that the common end of each of the two resistor pairs overlap, thus allowing a 12W Jxl pin header to take the place of the resistor pair. for use with 2mm jumpers for development boards (Harwin)

Linear Modulation Technology Ltd Cross Keys House Westfield Industrial Estate Middomer Norton Bath BA3 4BB			
BASE RECEIVER SPU AUDIO			
SIZE	FSCH NO	DMG NO	REV
A2	SPU3.SCH	LM0400002	1.2
May 30, 1995		SCALE	SHEET 2 OF 6

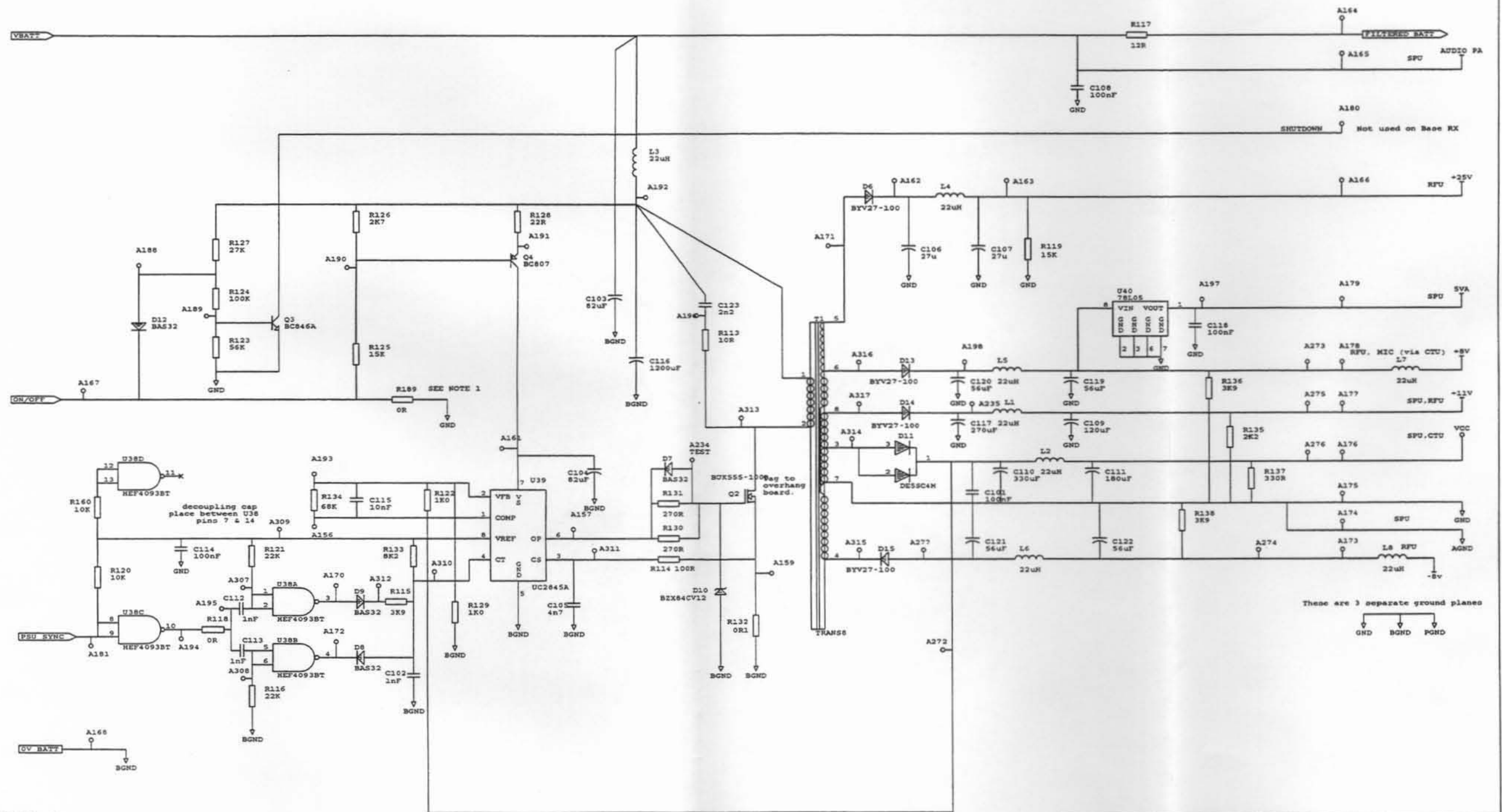

NOTE 1
This resistor overrides the ON/OFF line on base SPUs

Linear Modulation Technology Ltd Cross Keys House Westfield Industrial Estate Midcoker Norton Bath BA1 4BS			
BASE RECEIVER PSU			
DATE	FSCH NO	DWG NO	REV
June 5, 1995	A3 SPU4.SCH	LM040400002	1.2
SCALE		SHEET	6 OF 6

SPU/RFU Analogue Interface

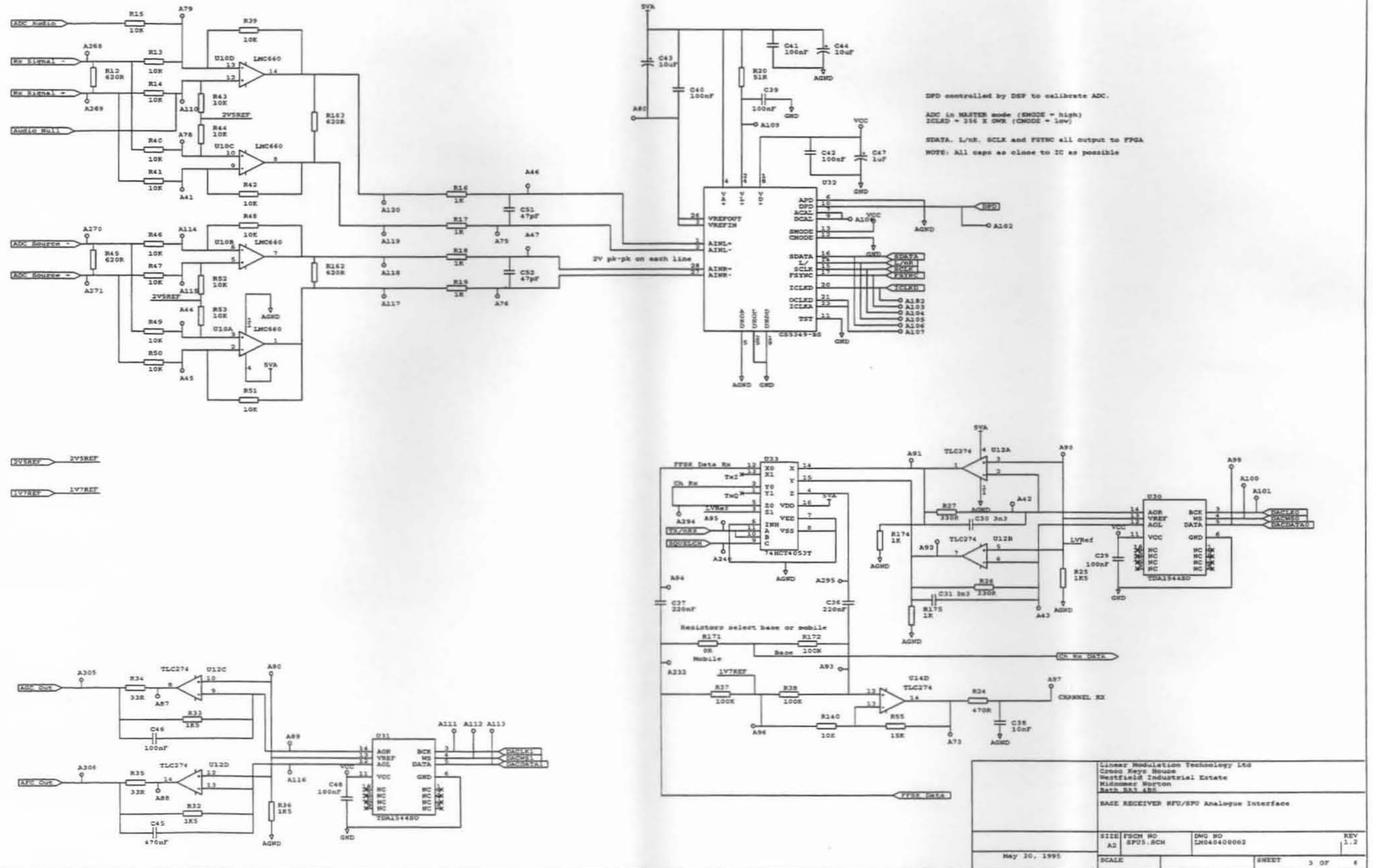

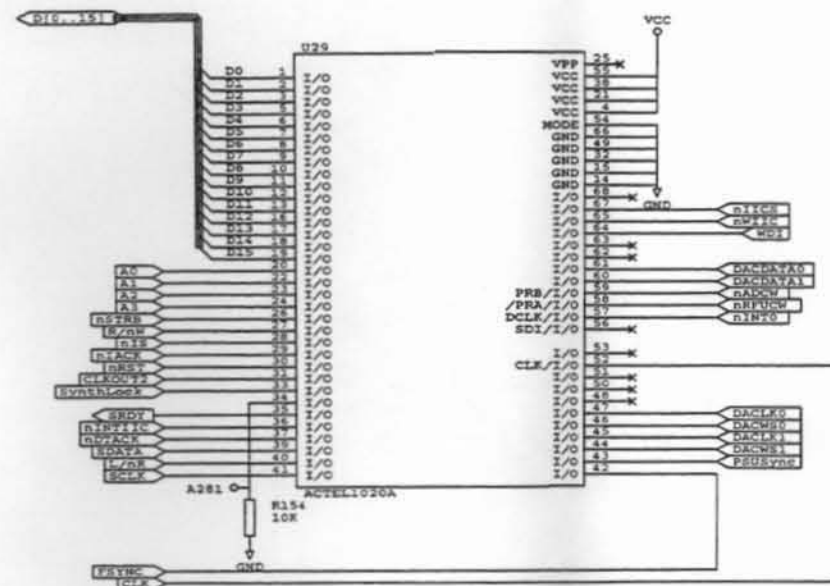

4 SPARC.
Pins 53, 56, 62 and 68

Linear Modulation Technology Ltd Cross Keys House Westfield Industrial Estate Midsomer Norton Bath BA1 4BS			
BASE RECEIVER SPU FPGA			
SIZE	FQCN NO	DWG NO	REV
A2	SPU6.SCH	LM04040002	1.2
May 30, 1995		SCALE	SHEET 5 OF 6



Module Parts List

USA 220 Channel Receiver

Document No: LM030301003

Issue 1.1

Reference	Description	Stock Number
2	SIDE PANEL	L004BSH1004A0
1	CONNECTOR BACK BOX	L004BSH1006A2
1	RECEIVER HOUSING	L004BSR1103A2
1	RECEIVER FRONT LMT	L004BSR1104B0
1	T0220 SIL PAD	L020T220IPDA0
1	TDA SIL PAD	L020TDAIPDXA0
1	SERIAL N/D LABEL	L026SNLABELB0
11	M2.5X6 P/HEAD TORX BZCP	L02925P6MMTA0
1	M3 X 10MM PAN HEAD TORX	L0293P10MMTA0
1	INSULATING TOP HAT T0220	L029INSTPH1A0
1	INSULATING TOP HAT	L029INSTPHTA0
34	M3X6 CSK TORX BZCP	L029M3C6MMTA0
12	M3 CRINKLE WASHER	L029M3CWASHA0
2	M3 NUT BZCP	L029M3NUTXXA0
15	M3X6 PAN HEAD TORX BZCP	L029M3P6MMTA0
6	M3-UNC4 LOCKING SCREWS	L029M3UNCLSA0
1	M3 PLAIN WASHER BZCP	L029M3WASHPA0
1	M3 SHAKEPROOF WASHER	L029M3WASHSA0
2	SLEEVE 3 x 20 RUBBER	L0323X20SLVA0
1	RX AUDIO LOOM	L033RXAUDIOA0
1	CONN RX LOOM	L033RXLR1IXC0
1	RX IN/IDC LOOM	L033RXLR2IXC0
1	POWER LOOM RX/TCC	L033RXLR3IXA1
1	RX IN/RG196 LOOM	L033RXLR4IXB0
1	10 MHz REF LOOM	L033RXLR5IXA0
1	RED LED 85 RING	L033RXLR6IXA1
1	INT POWER LOOM	L033RXLR7IXA0
1	48.3mm HANDLE M3X8 FIX	L035HANDLES A0
1	1000PF FILTER CON	L066FC1000PA0



21. Channel Exciter Unit

Contents

General Assemblies	21-3
Chassis.....	21-3
Looms	21-7
CONN TX Loom.....	L033EXLE1IXB0..... 21-7
10 MHz Ref Loom.....	L033EXLE5IXA0..... 21-8
Int Power Loom.....	L033EXLE9IXA0..... 21-9
PA Conns Loom.....	L033EXLE6IXA1..... 21-10
PA Drive Loom.....	L033EXLE4IXA0..... 21-11
Power Loom Exciter.....	L033EXLE3IXA1..... 21-12
Red LED 260 Ring.....	L033EXLE8IXA1..... 21-13
RF Feedback Loom.....	L033EXLE7IXA0..... 21-14
TX Out Loom.....	L033EXLE2IXB0..... 21-15
PCB Parts List	21-17
Radio Frequency Unit Exciter.....	21-17
Synthesiser Transmit.....	21-25
Signal Processing Unit Exciter.....	21-27
Overlays	21-32
Radio Frequency Unit Exciter v4.3.....	21-32
Radio Frequency Unit Exciter v5.2.....	21-34
Synthesiser Transmit.....	21-36
Signal Processing Unit Exciter.....	21-37
Circuit Diagrams	21-39
RFU Exciter.....	21-39
Synthesiser Transmit.....	21-51
SPU Exciter.....	21-53
Module Parts List	21-65

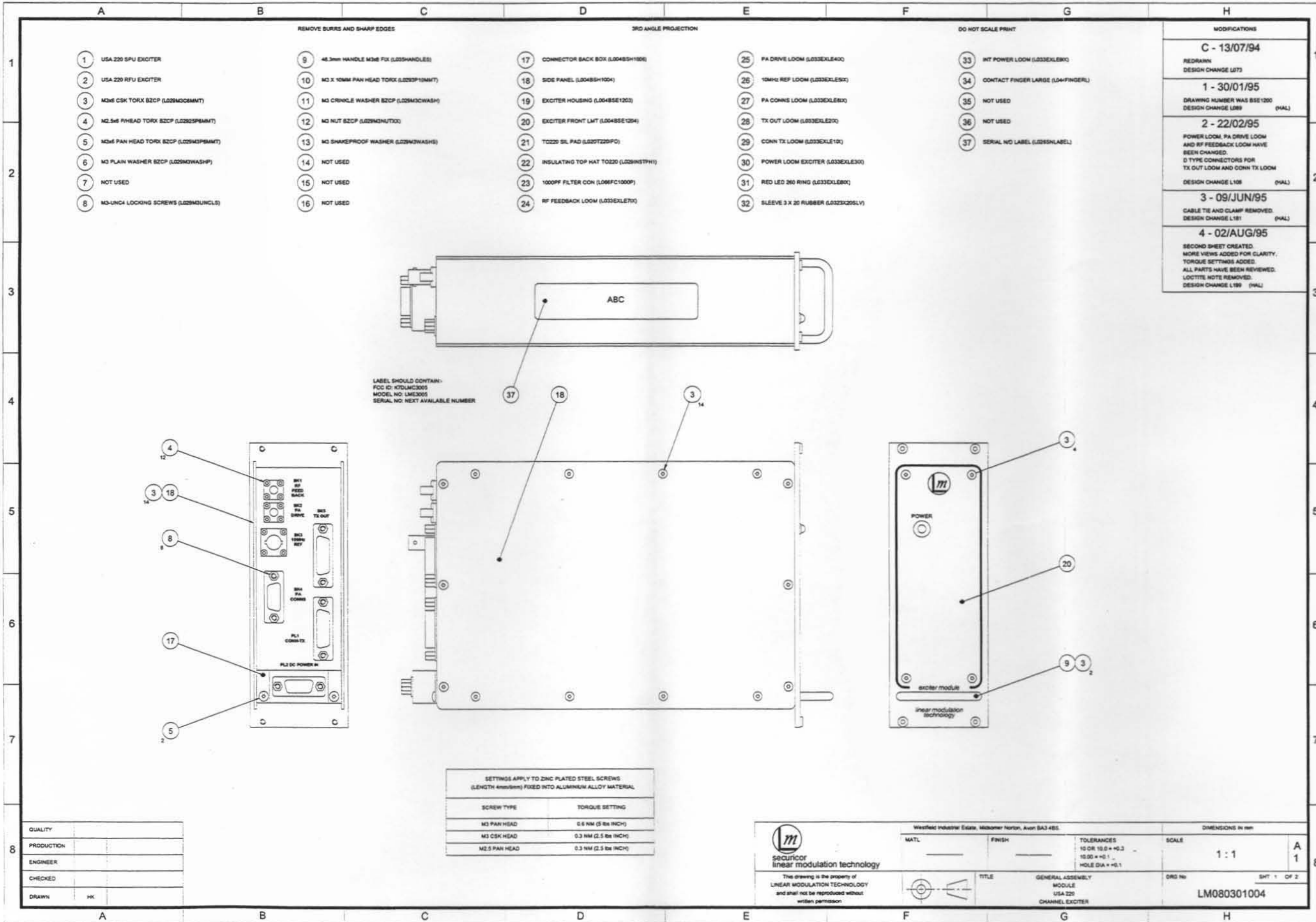

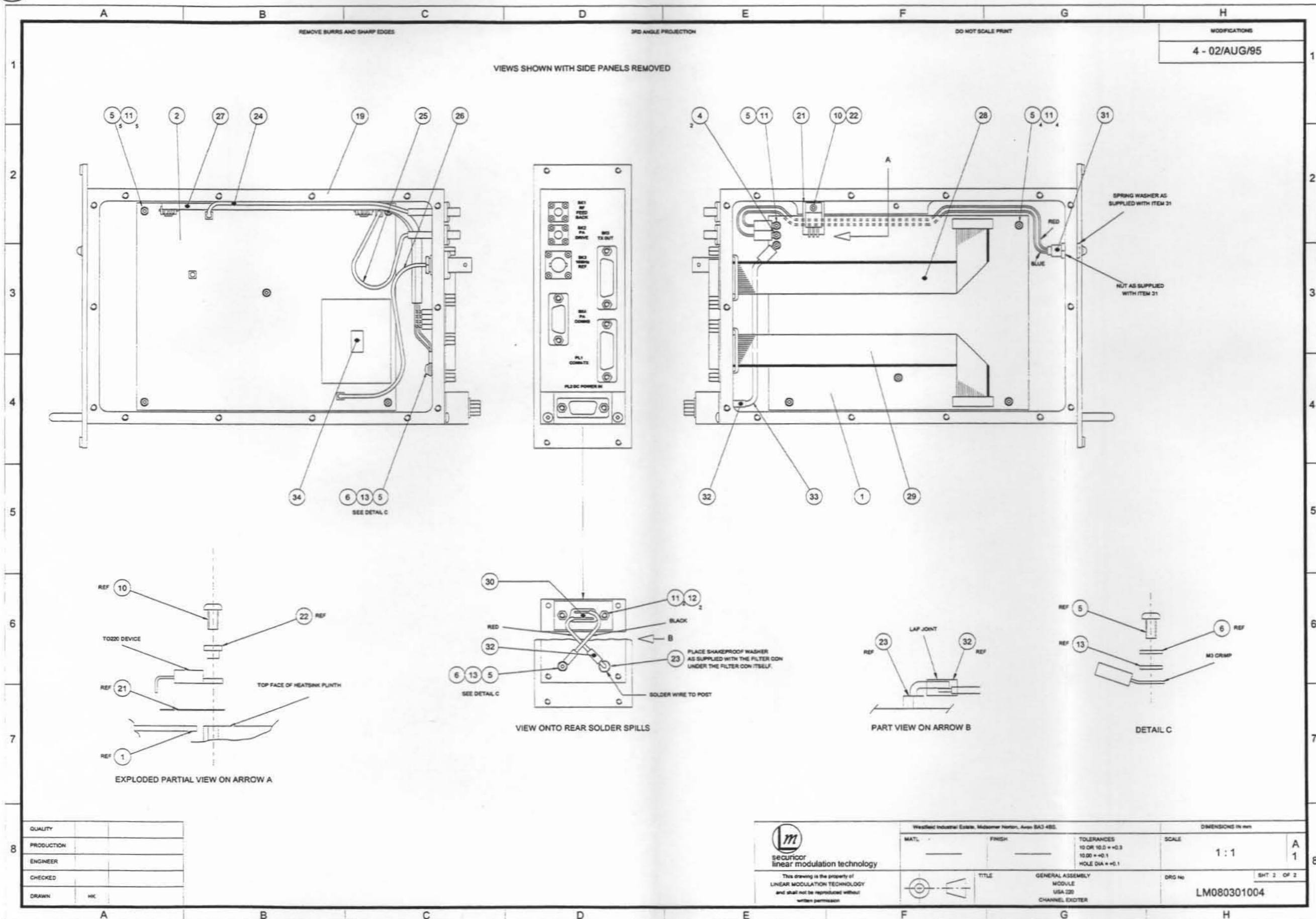

CHANNEL EXCITER UNIT



PROJECTION :-



START SK1	SEPARATION 85mm	FINISH PL1
PIN	FUNCTION	PIN
1	AUDIO(-)	1
2	AUDIO(+)	9
3	GRD	2
4	GRD	10
5	FFSK TX	3
6	FFSK RX	11
7	CONF	4
8	VOLUME	12
9	GRD	5
10	ON/OFF	13
11	GLORST	6
12	GRD	14
13	SCL	7
14	SDA	15
15	(+)8V	8
16		---

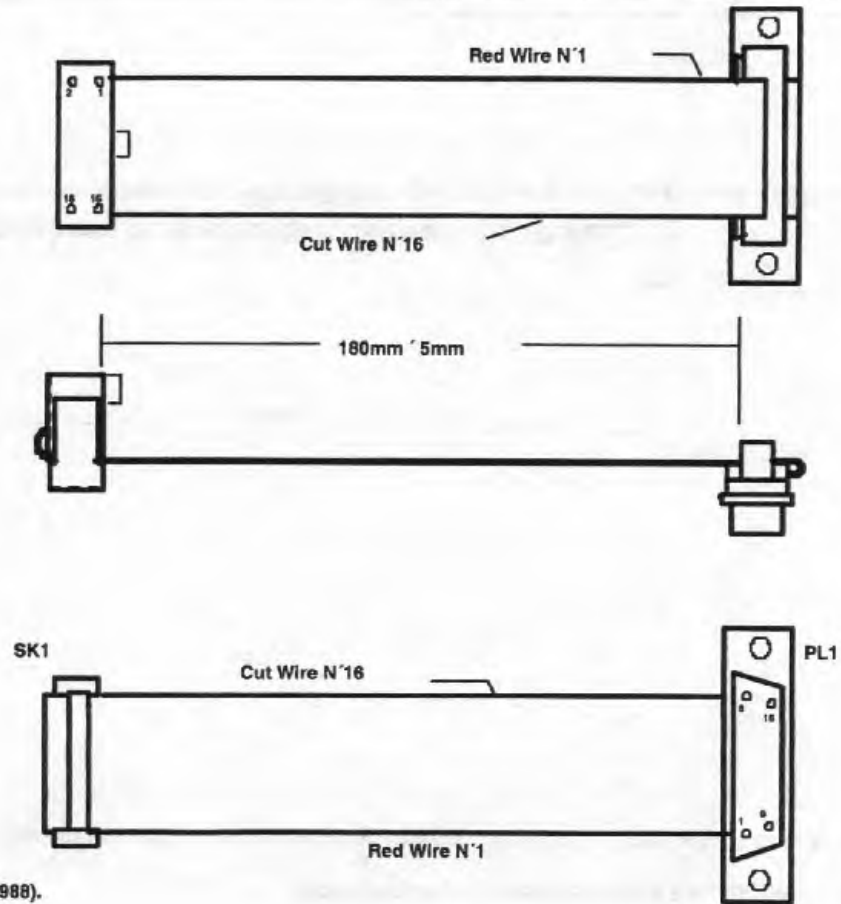

PL1 :- METAL D IDC PLUG 15-WAY TYPE CINCH FC15P (or equivalent).

SK1 :- BUMP-POLARISED IDC 16-WAY TYPE HARTING 09185166813 (or equivalent i.e. Farnell 248-988).

CABLE :- IDC RIBBON CABLE, GREY 0.05 PITCH (RED LEADING EDGE FOR WIRE N'1).

Note 1 :- Overall height of SK1 with strain-relief to not exceed 15.5mm max.

Drawing Up-Issue :- SK1 connector type changed/Note 1 added.

DRW:- 8LMT0004.L1I

TITLE :-

CONN TX LOOM. (Part L033EXLE1IX)

MAT :-

DRAWN :- B.PERRETT.

ISSUE :- 1.1

FIN :-

DATE :- 18.4.94.



PROJECTION :-

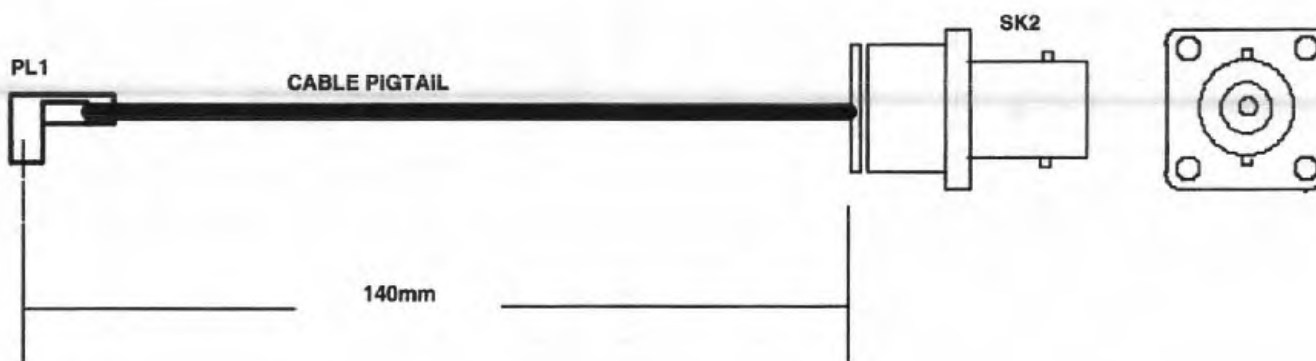
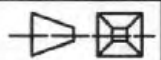

PL1/CABLE :- OMNI SPECTRA OSMT ANGLE JACK CABLE PIGTAIL 9950-2300-23 (or equivalent).

SK2 :- BNC/SK TYPE SUHNER 25 BNC 50-1-1C (or equivalent).

DRW:- 8LMT0004.L5I

TITLE :-

MAT :-

DRAWN :- B.PERRETT.

ISSUE :- 1.0

10MHz REF LOOM. (Part L033EXLE5IX)

FIN :-

DATE :- 18.4.94.

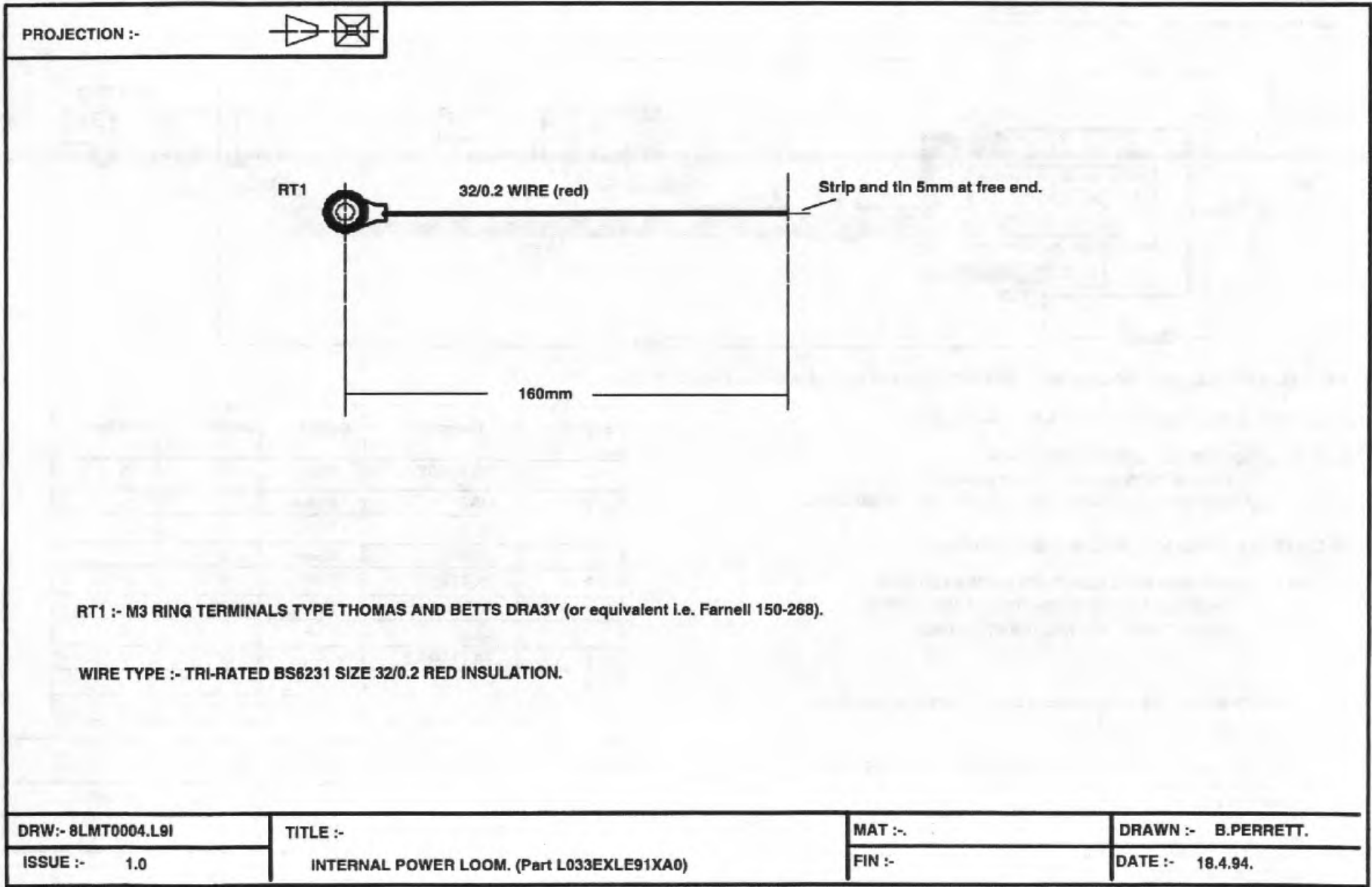

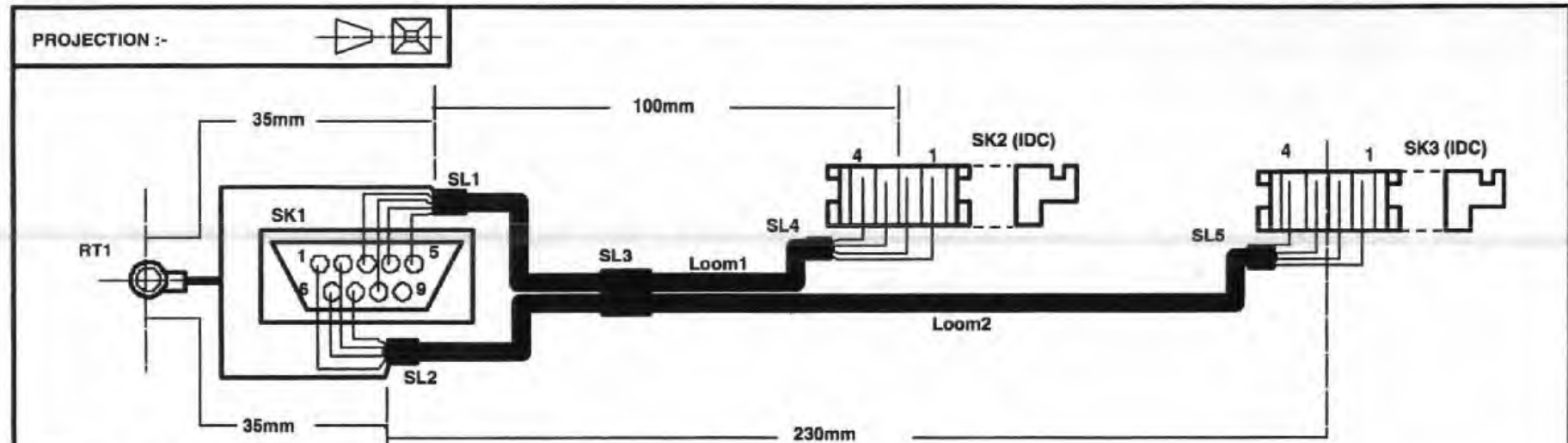

RT1 :- M3 RING TERMINAL TYPE THOMAS AND BETTS DRA3Y (or equivalent i.e. Farnell 150-268)

SK1:-SOLDER BUCKET 9-WAY D CONNECTOR (Farnell 105-509).

SK2/SK3 :- STOCKO IDC SOCKETS MKF8044-6-2-404.
 or STOCKO CRIMP SOCKETS MKH8124-1-0-400.
 (Stocko crimped sockets require contact type RFB8002.003)

SLEEVES SL1 TO SL5 ARE HELLERMANN H20BLACK.

LOOMS 1/2 :-LIGHT MINATURE SCREENED 4-CORE 10/0.1mm.
 FARNELL 140-481 (or equivalent).EACH SCREEN
 WIRED TO RT1 VIA TAIL UNDER SL1/SL2.

Note 1:- At SK1 solder bucket connections fit H12 Black 1.2mm sleeves

Note 2:- View of SK1 is onto solder buckets.

Note 3:-For Stocko contact Hesto (Henkels-Stocko) Ltd Tel (0707)50882]

SK1/Pin	Function	Colour	SK2/Pin	SK3/Pin
1	REVERSE	Red		1
2	(-)8V	Green		3
3	BATT MON	Red	1	
4	TX/nRX	Green	3	
5	PA TEMP	Blue	4	
6	FORWARD	Yellow		2
7	(+)8V	Blue		4
8	PA ENABLE	Yellow	2	
9	N/U			

Drawing Rev :- 35mm tails to RT1 were 60mm (nominal).(L0B3).

DRW:- 8LMT0004.L6I	TITLE :- PA CONNS LOOM. (Part L033EXLE6IX)	MAT :-	DRAWN :- B.PERRETT.
ISSUE :- 1.2		TOL :-10%	DATE :- 18.4.94.

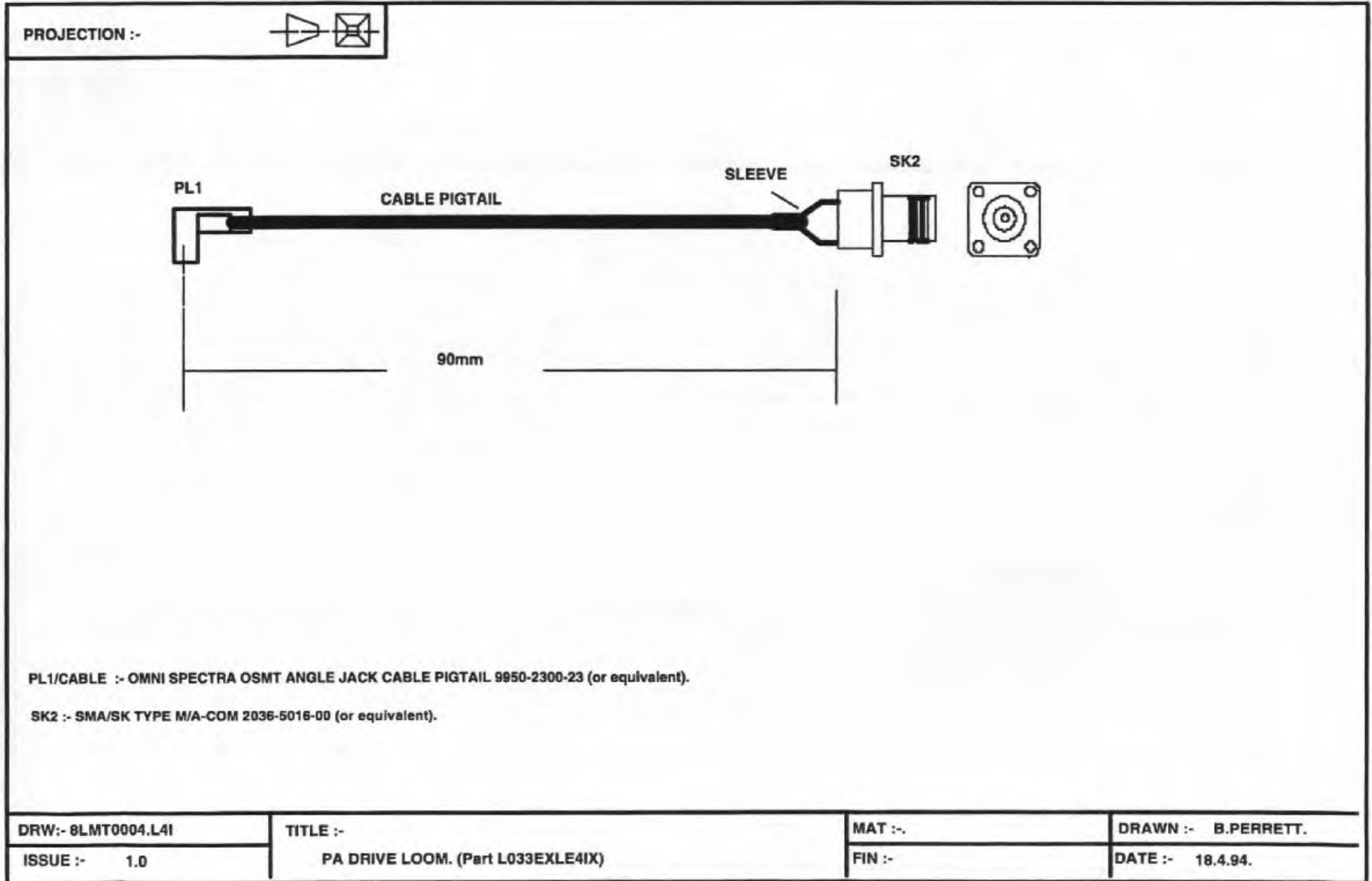



CHANNEL EXCITER UNIT

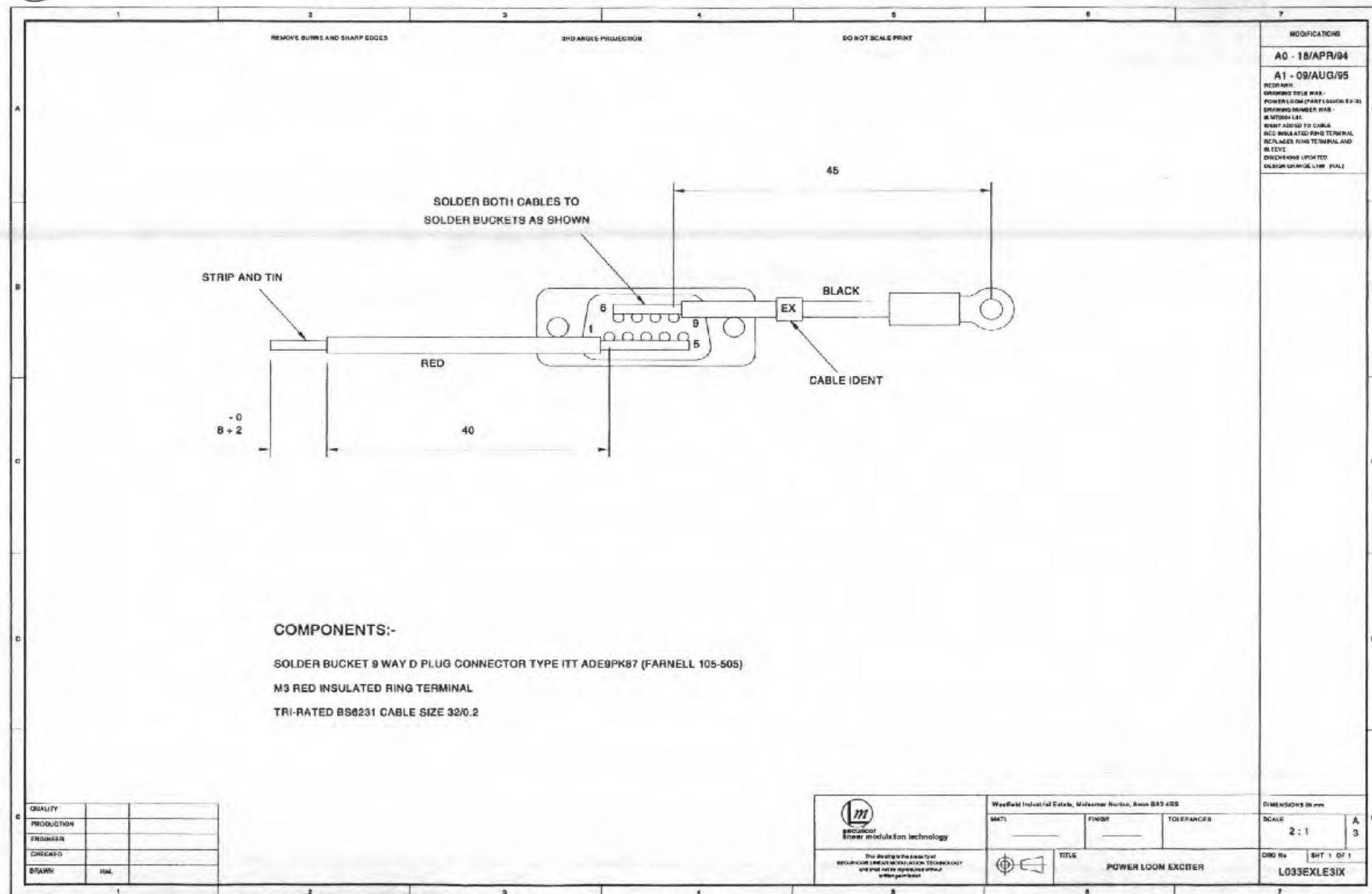

MODIFICATIONS

A0 - 18/APR/94

A1 - 09/AUG/95

REWORK
 DRAWING TITLE WAS:
 POWER LOOM (PART 1) (SHEET 2) OF 3
 DRAWING NUMBER WAS:
 L033EXLE3IX
 IDENT ADDED TO CABLE
 AND INSULATED RING TERMINAL
 REPLACES RING TERMINAL AND
 BELIEVE
 DIMENSIONS UPDATED
 DESIGN CHANGE L100 (HAL)

CHANNEL EXCITER UNIT

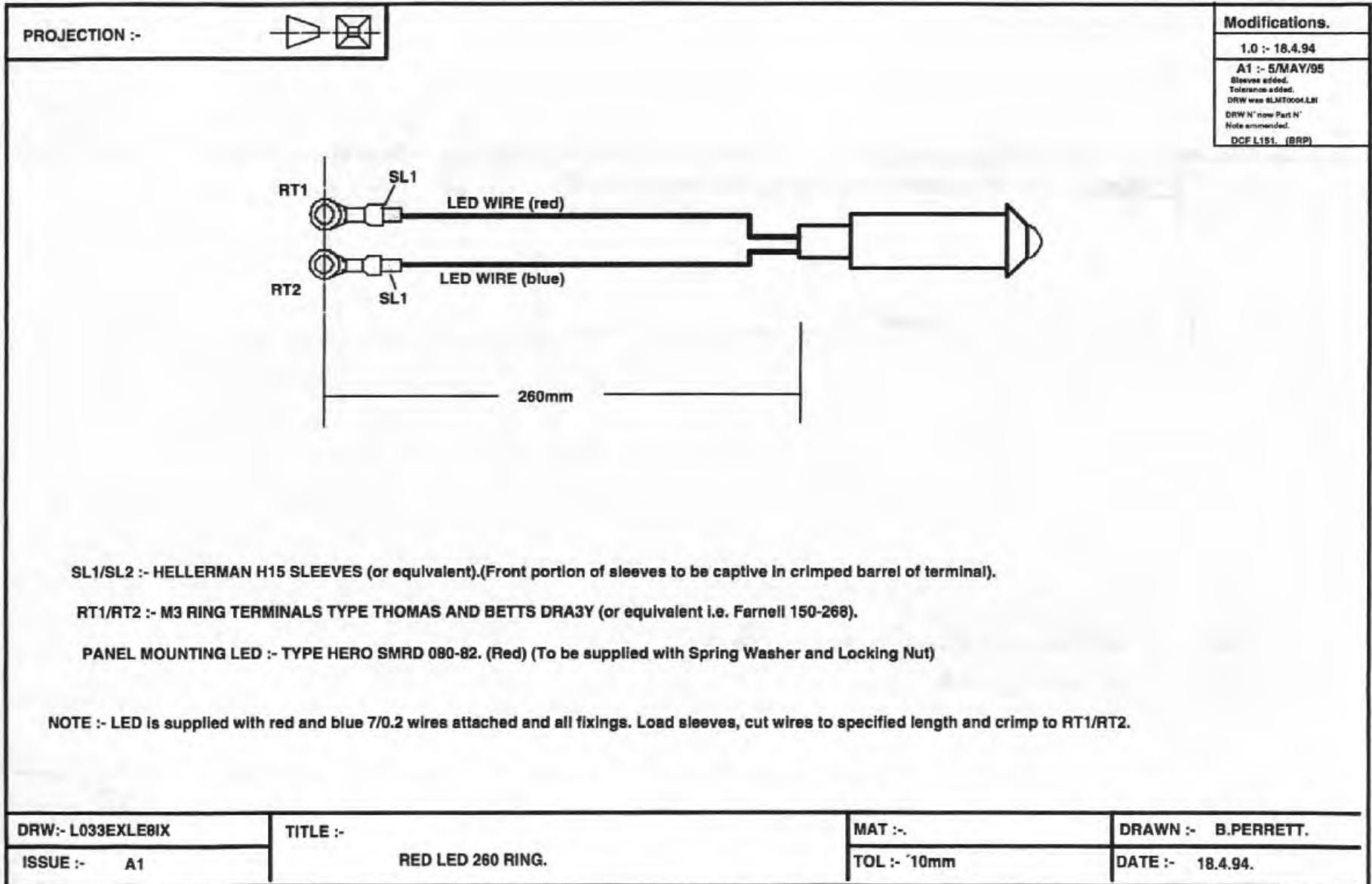



PROJECTION :-

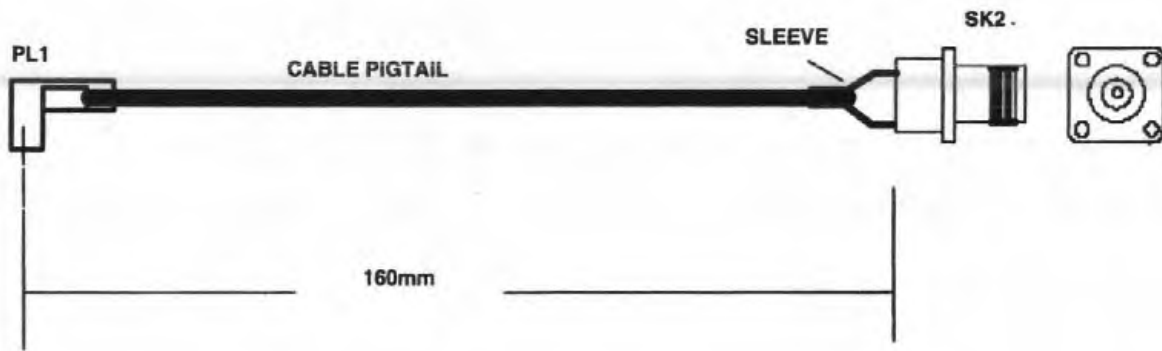
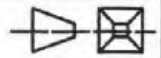

PL1/CABLE :- OMNI SPECTRA OSMT ANGLE JACK CABLE PIGTAIL 9950-2300-23 (or equivalent).

SK2 :- SMA/SK TYPE M/A-COM 2036-5016-00 (or equivalent).

DRW:- 8LMT0004.L71

TITLE :-

MAT :-

DRAWN :- B.PERRETT.

ISSUE :- 1.0

RF FEEDBACK LOOM. (Part L033EXLE7IX)

FIN :-

DATE :- 18.4.94.

CHANNEL EXCITER UNIT



PROJECTION :-

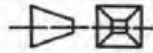

START SK1	SEPARATION 85mm	FINISH SK2
PIN	FUNCTION	PIN
1	PLL IN	1
2	PLL OUT	9
3	RXD	2
4	RTS	10
5	TXD	3
6	CTS	11
7	SPARE 1	4
8	SPARE 2	12
9	SER GRD	5
10	GRD 2	13
11	TX DATA (-)	6
12	TX DATA (+)	14
13	RX DATA (-)	7
14	RX DATA (+)	15
15	GRD 1	8
16		---

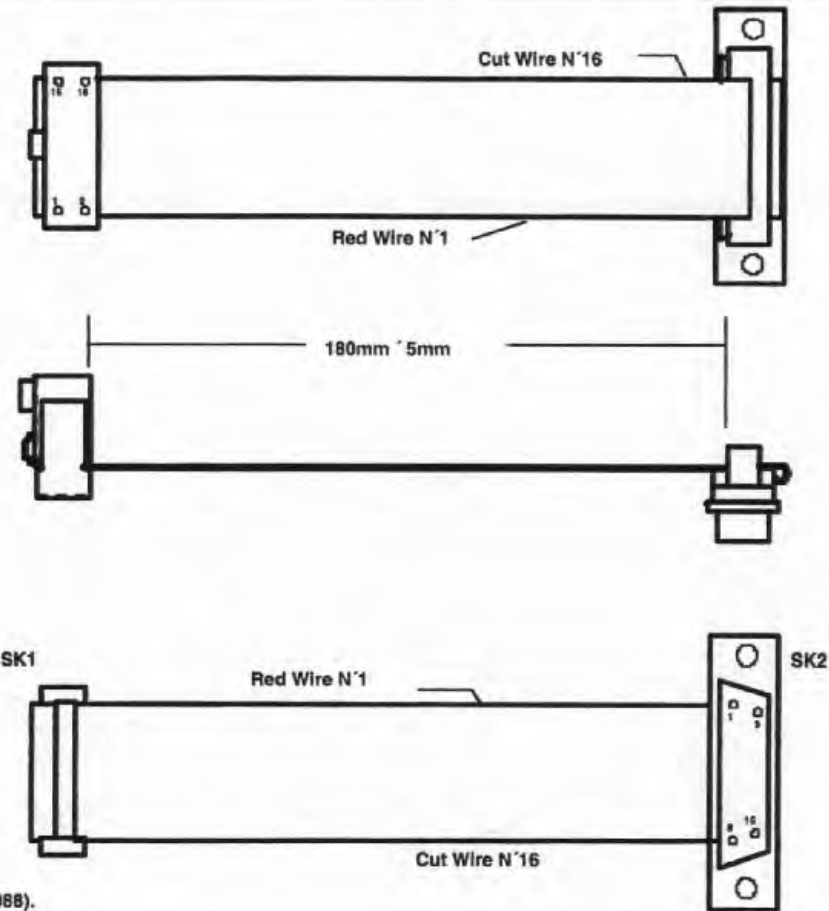

SK2 :- METAL D IDC SOCKET 15-WAY TYPE CINCH FC15S (or equivalent).

SK1 :- BUMP-POLARISED IDC 16-WAY TYPE HARTING 09185166813 (or equivalent i.e. Farnell 248-988).

CABLE :- IDC RIBBON CABLE, GREY 0.05 PITCH (RED LEADING EDGE FOR WIRE N°1).

Note :- Overall height of SK1 with strain relief to not exceed 15.5mm max.

Drawing Up-Issue :- SK1 connector type changed/Note 1 added.

DRW:- 8LMT0004.L2I	TITLE :-	MAT :-	DRAWN :- B.PERRETT.
ISSUE :- 1.1	TX OUT LOOM. (Part L033EXLE2IX)	FIN :-	DATE :- 18.4.94.



USA 220 Radio Frequency Unit Exciter

PCB Parts List

Document No: LM030401006

Issue 2.0

Reference	Description	Stock Number
C17	CAP SM ELECT 1uF 50V 20%	L067B105BEGA0
C18	CAP SM ELEC 10uF 16V 20%	L067B106BECA0
C21	CAP SM ELEC 10uF 16V 20%	L067B106BECA0
C22	CAP 100nF X7R ±10% 1206	L0674104AXGA0
C23	CAP 22pF NPO ±5% 0805	L06732205NGA0
C24	CAP 22pF NPO ±5% 0805	L06732205NGA0
C30	CAP 100nF X7R ±10% 1206	L0674104AXGA0
C31	CAP 10nF X7R ±10% 0805	L0673103AXGA0
C32	CAP 100pF NPO ±5% 0805	L06731015NGA0
C33	CAP 120pF NPO ±5% 0805	L06731215NGA0
C34	CAP 10nF X7R ±10% 0805	L0673103AXGA0
C35	CAP 10nF X7R ±10% 0805	L0673103AXGA0
C36	CAP 10nF X7R ±10% 0805	L0673103AXGA0
C37	CAP 10nF X7R ±10% 0805	L0673103AXGA0
C38	CAP 10nF X7R ±10% 0805	L0673103AXGA0
C70	CAP 10nF X7R ±10% 0805	L0673103AXGA0
C96	CAP 12pF NPO ±5% 0805	L06731205NGA0
C121	CAP 10nF X7R ±10% 0805	L0673103AXGA0
C122	CAP 100nF X7R ±10% 1206	L0674104AXGA0
C123	CAP SM ELECT 1uF 50V 20%	L067B105BEGA0
C124	CAP 10nF X7R ±10% 0805	L0673103AXGA0
C204	CAP 1nF X7R ±10% 0805	L0673102AXGA0
C211	CAP 100nF X7R ±10% 1206	L0674104AXGA0
C212	CAP 100nF X7R ±10% 1206	L0674104AXGA0
C213	680pF SM NPO 0805 50V	L0673681ANGA0
C214	680pF SM NPO 0805 50V	L0673681ANGA0
C215	680pF SM NPO 0805 50V	L0673681ANGA0
C216	680pF SM NPO 0805 50V	L0673681ANGA0
C217	CAP 100nF X7R ±10% 1206	L0674104AXGA0
C218	CAP 100nF X7R ±10% 1206	L0674104AXGA0
C219	CAP 68pF NPO ±5% 0805	L06736805NGA0
C220	CAP 10nF X7R ±10% 0805	L0673103AXGA0
C221	CAP 150nF POLYESTER	L06691540PFA0
C223	CAP 100nF X7R ±10% 1206	L0674104AXGA0
C224	CAP 100nF X7R ±10% 1206	L0674104AXGA0
C225	680pF SM NPO 0805 50V	L0673681ANGA0
C226	680pF SM NPO 0805 50V	L0673681ANGA0
C227	680pF SM NPO 0805 50V	L0673681ANGA0
C228	680pF SM NPO 0805 50V	L0673681ANGA0
C229	CAP 68pF NPO ±5% 0805	L06736805NGA0
C230	CAP 100nF X7R ±10% 1206	L0674104AXGA0
C231	CAP 100nF X7R ±10% 1206	L0674104AXGA0
C232	CAP 10nF X7R ±10% 0805	L0673103AXGA0
C233	CAP 150nF POLYESTER	L06691540PFA0
C234	CAP 1nF X7R ±10% 0805	L0673102AXGA0
C235	CAP 12pF NPO ±5% 0805	L06731205NGA0



C236	CAP 22pF NPO ±5% 0805	L06732205NGA0
C237	CAP 12pF NPO ±5% 0805	L06731205NGA0
C238	CAP 1nF X7R ±10% 0805	L0673102AXGA0
C239	CAP 1nF X7R ±10% 0805	L0673102AXGA0
C240	CAP 10pF NPO ±5% 0805	L06731005NGA0
C241	CAP 12pF NPO ±5% 0805	L06731205NGA0
C242	CAP 1nF X7R ±10% 0805	L0673102AXGA0
C243	CAP 1nF X7R ±10% 0805	L0673102AXGA0
C244	CAP 8p2 NPO ±0.25pF 0805	L0673822CNGA0
C245	CAP 8p2 NPO ±0.25pF 0805	L0673822CNGA0
C246	CAP 100pF NPO ±5% 0805	L06731015NGA0
C247	CAP 1nF X7R ±10% 0805	L0673102AXGA0
C248	CAP 1nF X7R ±10% 0805	L0673102AXGA0
C249	CAP 1nF X7R ±10% 0805	L0673102AXGA0
C250	CAP 15pF NPO ±5% 0805	L06731505NGA0
C251	CAP 1nF X7R ±10% 0805	L0673102AXGA0
C252	CAP 8p2 NPO ±0.25pF 0805	L0673822CNGA0
C253	CAP 8p2 NPO ±0.25pF 0805	L0673822CNGA0
C254	CAP 6p8 NPO ±0.25pF 0805	L0673682CNGA0
C255	CAP 12pF NPO ±5% 0805	L06731205NGA0
C256	CAP 22pF NPO ±5% 0805	L06732205NGA0
C257	CAP 1nF X7R ±10% 0805	L0673102AXGA0
C258	CAP 1nF X7R ±10% 0805	L0673102AXGA0
C259	CAP 1nF X7R ±10% 0805	L0673102AXGA0
C260	CAP 4p7 NPO ±0.25p 0805	L0673472CNGA0
C261	CAP 15pF NPO ±5% 0805	L06731505NGA0
C262	CAP SM ELEC 10uF 16V 20%	L067B106BECA0
C263	CAP 1nF X7R ±10% 0805	L0673102AXGA0
C264	CAP 1nF X7R ±10% 0805	L0673102AXGA0
C265	CAP 12pF NPO ±5% 0805	L06731205NGA0
C266	CAP 1nF X7R ±10% 0805	L0673102AXGA0
C267	CAP 6p8 NPO ±0.25pF 0805	L0673682CNGA0
C268	CAP 1nF X7R ±10% 0805	L0673102AXGA0
C269	CAP 1nF X7R ±10% 0805	L0673102AXGA0
C270	CAP 1nF X7R ±10% 0805	L0673102AXGA0
C271	CAP 15pF NPO ±5% 0805	L06731505NGA0
C272	CAP 1nF X7R ±10% 0805	L0673102AXGA0
C273	CAP 8p2 NPO ±0.25pF 0805	L0673822CNGA0
C274	CAP 8p2 NPO ±0.25pF 0805	L0673822CNGA0
C275	CAP 10uF 16V 20% [SM C]	L0679106BTCA0
C276	CAP 10uF 16V 20% [SM C]	L0679106BTCA0
C277	CAP 10uF 16V 20% [SM C]	L0679106BTCA0
C278	CAP 10uF 16V 20% [SM C]	L0679106BTCA0
C279	CAP 10uF 16V 20% [SM C]	L0679106BTCA0
C280	CAP 100nF X7R ±10% 1206	L0674104AXGA0
C281	CAP 10uF 16V 20% [SM C]	L0679106BTCA0
C282	CAP 100nF X7R ±10% 1206	L0674104AXGA0
C283	CAP 330pF NPO ±5% 0805	L06733315NGA0
C284	CAP 330pF NPO ±5% 0805	L06733315NGA0
C285	CAP 100nF X7R ±10% 1206	L0674104AXGA0
C286	CAP 100nF X7R ±10% 1206	L0674104AXGA0
C287	CAP 100nF X7R ±10% 1206	L0674104AXGA0
C290	CAP 1nF X7R ±10% 0805	L0673102AXGA0
C291	CAP 1nF X7R ±10% 0805	L0673102AXGA0
C293	CAP 1nF X7R ±10% 0805	L0673102AXGA0
C294	CAP 1nF X7R ±10% 0805	L0673102AXGA0
C295	CAP 15pF NPO ±5% 0805	L06731505NGA0
C297	CAP 15pF NPO ±5% 0805	L06731505NGA0
C298	CAP 1nF X7R ±10% 0805	L0673102AXGA0
C299	CAP 1nF X7R ±10% 0805	L0673102AXGA0
C300	CAP 1nF X7R ±10% 0805	L0673102AXGA0
C301	CAP 1nF X7R ±10% 0805	L0673102AXGA0
C302	CAP 1nF X7R ±10% 0805	L0673102AXGA0



C303	CAP 1nF X7R ±10% 0805	L0673102AXGA0
C304	CAP 1nF X7R ±10% 0805	L0673102AXGA0
C305	CAP 1nF X7R ±10% 0805	L0673102AXGA0
C306	1uF LEADED POLY 50V 20%	L0669105BPGA0
C307	1uF LEADED POLY 50V 20%	L0669105BPGA0
C308	CAP SM ELECT 1uF 50V 20%	L067B105BEGA0
C309	CAP 100nF X7R ±10% 1206	L0674104AXGA0
C310	CAP 1nF X7R ±10% 0805	L0673102AXGA0
C311	CAP 1nF X7R ±10% 0805	L0673102AXGA0
C312	CAP 100pF NPO ±5% 0805	L06731015NGA0
C313	CAP 100pF NPO ±5% 0805	L06731015NGA0
C314	CAP 100pF NPO ±5% 0805	L06731015NGA0
C315	CAP 100pF NPO ±5% 0805	L06731015NGA0
C316	CAP 100pF NPO ±5% 0805	L06731015NGA0
C317	CAP 100pF NPO ±5% 0805	L06731015NGA0
C318	CAP 1nF X7R ±10% 0805	L0673102AXGA0
C319	CAP 1nF X7R ±10% 0805	L0673102AXGA0
C322	CAP 100nF X7R ±10% 1206	L0674104AXGA0
C323	CAP 1nF X7R ±10% 0805	L0673102AXGA0
C324	CAP 1nF X7R ±10% 0805	L0673102AXGA0
C325	CAP 1nF X7R ±10% 0805	L0673102AXGA0
C326	CAP 1nF X7R ±10% 0805	L0673102AXGA0
C327	CAP 100pF NPO ±5% 0805	L06731015NGA0
C328	CAP 100pF NPO ±5% 0805	L06731015NGA0
C329	CAP 12pF NPO ±5% 0805	L06731205NGA0
C330	CAP 12pF NPO ±5% 0805	L06731205NGA0
C350	36p SM NPO 0805 50V 5%	L06733605NGA0
C351	36p SM NPO 0805 50V 5%	L06733605NGA0
C352	CAP 15pF NPO ±5% 0805	L06731505NGA0
C356	CAP 100pF NPO ±5% 0805	L06731015NGA0
C357	CAP 150nF POLYESTER	L06691540PFA0
D3	HSMP 3800 [SOT-23]	L063SHP3800A0
D4	HSMP 3800 [SOT-23]	L063SHP3800A0
D5	HSMP 3800 [SOT-23]	L063SHP3800A0
D6	HSMP 3800 [SOT-23]	L063SHP3800A0
D7	HSMP 3800 [SOT-23]	L063SHP3800A0
D16	BAT18 [SOT-23]	L063SBAT18XA0
D17	BAT18 [SOT-23]	L063SBAT18XA0
D18	BAT18 [SOT-23]	L063SBAT18XA0
D19	BAT18 [SOT-23]	L063SBAT18XA0
D20	BAT18 [SOT-23]	L063SBAT18XA0
D21	BAT18 [SOT-23]	L063SBAT18XA0
D22	BB515 [SOD-123]	L063SBB515XA0
D23	BB515 [SOD-123]	L063SBB515XA0
D24	HSMP 3800 [SOT-23]	L063SHP3800A0
D25	HSMP 3800 [SOT-23]	L063SHP3800A0
D26	HSMP 3800 [SOT-23]	L063SHP3800A0
D27	BAS16 [SOT 23]	L063SBAS16XA0
IC1	78L08 [SO-8]	L05778L08SXA0
IC2	LMC660AIM [SO-14]	L057LMC660MA0
IC8	74HCT00 [SO-14]	L057HCT00SXA0
IC9	74HCT04 [SO-14]	L057HCT04SXA0
IC11	74HC373 SO-20W	L057HC373SXA0
IC12	78L05 [SO-8]	L05778L05SXA0
IC25	TL0741D [SO-14]	L057TL0741DA0
IC26	OP-27GS [SO-8]	L057SOP27GSA0
IC27	NE5537 [8-DIL]	L057S5537XXA0
IC28	74HCT4052 [SO-16]	L057HCT4052A0
IC29	TL0741D [SO-14]	L057TL0741DA0
IC30	OP-27GS [SO-8]	L057SOP27GSA0
IC31	NE5537 [8-DIL]	L057S5537XXA0
IC32	74HCT04 [SO-14]	L057HCT04SXA0
IC33	TL0741D [SO-14]	L057TL0741DA0



IC34	78L05 [SO-8]	L05778L05SXA0
IC35	79L05 [TO-92]	L05779L05LXA0
IC37	OP37GS [SO-8]	L057SOP37GSA0
IC38	OP37GS [SO-8]	L057SOP37GSA0
IC39	OP37GS [SO-8]	L057SOP37GSA0
IC40	OP37GS [SO-8]	L057SOP37GSA0
IC41	74HCT4051 [SO-14]	L057HCT4051A0
IC42	BA15532F [SO-8]	L057S5532XXA0
IC43	78L15 [SO-8]	L05778L15SXA0
L9	IND 220nH 10% [1008]	L06482240CXA0
L38	IND 39nH 5% [1008]	L06483935CXA0
L39	IND 39nH 5% [1008]	L06483935CXA0
L40	IND 39nH 5% [1008]	L06483935CXA0
L41	IND 39nH 5% [1008]	L06483935CXA0
L42	IND 39nH 5% [1008]	L06483935CXA0
L43	IND 39nH 5% [1008]	L06483935CXA0
L44	IND 39nH 5% [1008]	L06483935CXA0
L45	IND 39nH 5% [1008]	L06483935CXA0
L46	IND 39nH 5% [1008]	L06483935CXA0
L47	IND 39nH 5% [1008]	L06483935CXA0
L48	IND 39nH 5% [1008]	L06483935CXA0
L49	IND 39nH 5% [1008]	L06483935CXA0
L50	IND 39nH 5% [1008]	L06483935CXA0
L51	IND 22nH 10% [1008]	L06482230CXA0
L52	IND 22nH 10% [1008]	L06482230CXA0
L53	180n SM CHIP 1008 10%	L0649183ACXA0
L54	IND 47nH 10% [1008]	L0648473ACXA0
L55	IND 47nH 10% [1008]	L0648473ACXA0
MX4	TUF-1 FREQUENCY MIXER	L057TUF-1XXA0
MX5	TUF-1 FREQUENCY MIXER	L057TUF-1XXA0
MX6	TUF-1 FREQUENCY MIXER	L057TUF-1XXA0
MX7	TUF-1 FREQUENCY MIXER	L057TUF-1XXA0
PCB1	RFU PCB	L001RFUPCBXB0
PL3	4 X 1 LATCHED PIN HEADER	L0134X12MMPA0
PL4	4 X 1 LATCHED PIN HEADER	L0134X12MMPA0
PL6	50_ SUB MIN COAX CON SM	L0130SMTPCBA0
PL7	50_ SUB MIN COAX CON SM	L0130SMTPCBA0
PL8	50_ SUB MIN COAX CON SM	L0130SMTPCBA0
PL13	3 X 1 TERMINAL STRIP	L01303X1TSXA0
PL14	3 X 1 TERMINAL STRIP	L01303X1TSXA0
PL15	6 X 1 TERMINAL STRIP	L01306X1TSXA0
R8	RES 39K 0.1W ±2% 0805	L07133932POA0
R9	RES 10K 0.1W ±2% 0805	L07131032POA0
R10	RES 2K2 0.1W ±2% 0805	L07132222POA0
R11	RES 10K 0.1W ±2% 0805	L07131032POA0
R17	RES 39K 0.1W ±2% 0805	L07133932POA0
R18	RES 10K 0.1W ±2% 0805	L07131032POA0
R22	RES 2K2 0.1W ±2% 0805	L07132222POA0
R23	RES 10K 0.1W ±2% 0805	L07131032POA0
R28	RES 100K 0.1W ±2% 0805	L07131042POA0
R29	RES 10K 0.1W ±2% 0805	L07131032POA0
R30	RES 3K3 0.1W ±2% 0805	L07133322POA0
R31	RES 220K 0.1W ±2% 0805	L07132242POA0
R32	RES 330R 0.1W ±2% 0805	L07133312POA0
R33	RES 1K 0.1W ±2% 0805	L07131022POA0
R34	RES 100K 0.1W ±2% 0805	L07131042POA0
R35	RES 150K 0.1W ±2% 0805	L07131542POA0
R36	RES 330R 0.1W ±2% 0805	L07133312POA0
R37	RES 10K 0.1W ±2% 0805	L07131032POA0
R38	RES 3K3 0.1W ±2% 0805	L07133322POA0
R39	RES 150R 0.1W ±2% 0805	L07131512POA0
R40	RES 10R 0.1W ±2% 0805	L07131002POA0
R41	RES 470R 0.1W ±2% 0805	L07134712POA0



R42	RES 2K7 0.1W ±2% 0805	L07132722P0A0
R43	RES 33R 0.1W ±2% 0805	L07133302P0A0
R44	RES 1K 0.1W ±2% 0805	L07131022P0A0
R45	RES 470R 0.1W ±2% 0805	L07134712P0A0
R46	RES 2K7 0.1W ±2% 0805	L07132722P0A0
R47	RES 33R 0.1W ±2% 0805	L07133302P0A0
R48	RES 1K 0.1W ±2% 0805	L07131022P0A0
R49	RES 470R 0.1W ±2% 0805	L07134712P0A0
R50	RES 2K7 0.1W ±2% 0805	L07132722P0A0
R51	RES 33R 0.1W ±2% 0805	L07133302P0A0
R107	RES 10K 0.1W ±2% 0805	L07131032P0A0
R108	RES 4K7 0.1W ±2% 0805	L07134722P0A0
R109	RES 470R 0.1W ±2% 0805	L07134712P0A0
R110	RES 150R 0.1W ±2% 0805	L07131512P0A0
R175	RES 100R 0.1W ±2% 0805	L07131012P0A0
R176	RES 100R 0.1W ±2% 0805	L07131012P0A0
R177	RES 390R 0.1W ±2% 0805	L07133912P0A0
R178	RES 10K 0.1W ±2% 0805	L07131032P0A0
R179	RES 10K 0.1W ±2% 0805	L07131032P0A0
R180	RES 56K 0.1W ±2% 0805	L07135632P0A0
R181	RES 56K 0.1W ±2% 0805	L07135632P0A0
R182	RES 27K 0.1W ±2% 0805	L07132732P0A0
R183	RES 27K 0.1W ±2% 0805	L07132732P0A0
R184	RES 4K7 0.1W ±2% 0805	L07134722P0A0
R185	RES 39K 0.1W ±2% 0805	L07133932P0A0
R186	RES 27K 0.1W ±2% 0805	L07132732P0A0
R187	RES 27K 0.1W ±2% 0805	L07132732P0A0
R188	RES 43K 0.1W ±2% 0805	L07134332P0A0
R189	RES 39K 0.1W ±2% 0805	L07133932P0A0
R190	RES 1K 0.1W ±2% 0805	L07131022P0A0
R191	RES 4K7 0.1W ±2% 0805	L07134722P0A0
R192	RES 100K 0.1W ±2% 0805	L07131042P0A0
R193	RES 4K7 0.1W ±2% 0805	L07134722P0A0
R194	RES 1M0 0.1W ±2% 0805	L07131052P0A0
R196	RES 10K 0.1W ±2% 0805	L07131032P0A0
R197	RES 820R 0.1W ±2% 0805	L07138212P0A0
R198	RES 100R 0.1W ±2% 0805	L07131012P0A0
R199	RES 100R 0.1W ±2% 0805	L07131012P0A0
R200	RES 390R 0.1W ±2% 0805	L07133912P0A0
R201	RES 10K 0.1W ±2% 0805	L07131032P0A0
R202	RES 10K 0.1W ±2% 0805	L07131032P0A0
R203	RES 56K 0.1W ±2% 0805	L07135632P0A0
R204	RES 56K 0.1W ±2% 0805	L07135632P0A0
R205	RES 27K 0.1W ±2% 0805	L07132732P0A0
R206	RES 27K 0.1W ±2% 0805	L07132732P0A0
R207	RES 4K7 0.1W ±2% 0805	L07134722P0A0
R208	RES 39K 0.1W ±2% 0805	L07133932P0A0
R209	RES 27K 0.1W ±2% 0805	L07132732P0A0
R210	RES 27K 0.1W ±2% 0805	L07132732P0A0
R211	RES 43K 0.1W ±2% 0805	L07134332P0A0
R212	RES 39K 0.1W ±2% 0805	L07133932P0A0
R213	RES 4K7 0.1W ±2% 0805	L07134722P0A0
R214	RES 1K 0.1W ±2% 0805	L07131022P0A0
R215	RES 4K7 0.1W ±2% 0805	L07134722P0A0
R216	RES 100K 0.1W ±2% 0805	L07131042P0A0
R217	RES 1M0 0.1W ±2% 0805	L07131052P0A0
R218	RES 10K 0.1W ±2% 0805	L07131032P0A0
R219	RES 820R 0.1W ±2% 0805	L07138212P0A0
R220	RES 1K8 0.1W ±2% 0805	L07131822P0A0
R221	RES 1K8 0.1W ±2% 0805	L07131822P0A0
R222	RES 1K8 0.1W ±2% 0805	L07131822P0A0
R223	RES 1K8 0.1W ±2% 0805	L07131822P0A0
R224	RES 1K8 0.1W ±2% 0805	L07131822P0A0



R225	RES 1K8 0.1W ±2% 0805	L07131822P0A0
R226	RES 100K 0.1W ±2% 0805	L07131042P0A0
R227	RES 100K 0.1W ±2% 0805	L07131042P0A0
R228	RES 4K7 0.1W ±2% 0805	L07134722P0A0
R229	RES 2K2 0.1W ±2% 0805	L07132222P0A0
R230	RES 470R 0.1W ±2% 0805	L07134712P0A0
R231	RES 100R 0.1W ±2% 0805	L07131012P0A0
R233	RES 330R 0.1W ±2% 0805	L07133312P0A0
R234	RES 18R 0.1W ±2% 0805	L07131802P0A0
R235	RES 330R 0.1W ±2% 0805	L07133312P0A0
R236	RES 51R 0.1W ±2% 0805	L07135102P0A0
R237	RES 51R 0.1W ±2% 0805	L07135102P0A0
R238	RES 51R 0.1W ±2% 0805	L07135102P0A0
R239	RES 100R 0.1W ±2% 0805	L07131012P0A0
R240	RES 27K 0.1W ±2% 0805	L07132732P0A0
R241	RES 56K 0.1W ±2% 0805	L07135632P0A0
R242	RES 56K 0.1W ±2% 0805	L07135632P0A0
R243	RES 56K 0.1W ±2% 0805	L07135632P0A0
R244	RES 220K 0.1W ±2% 0805	L07132242P0A0
R245	RES 220K 0.1W ±2% 0805	L07132242P0A0
R246	RES 220K 0.1W ±2% 0805	L07132242P0A0
R247	RES 15K 0.1W ±2% 0805	L07131532P0A0
R248	RES 10K 0.1W ±2% 0805	L07131032P0A0
R249	RES 100K 0.1W ±2% 0805	L07131042P0A0
R250	RES 10K 0.1W ±2% 0805	L07131032P0A0
R251	RES 100K 0.1W ±2% 0805	L07131042P0A0
R252	RES 4K7 0.1W ±2% 0805	L07134722P0A0
R253	RES 10K 0.1W ±2% 0805	L07131032P0A0
R254	RES 2K7 0.1W ±2% 0805	L07132722P0A0
R255	RES 1K 0.1W ±2% 0805	L07131022P0A0
R256	RES 470R 0.1W ±2% 0805	L07134712P0A0
R257	RES 150R 0.1W ±2% 0805	L07131512P0A0
R258	RES 3K9 0.1W ±2% 0805	L07133922P0A0
R259	RES 820R 0.1W ±2% 0805	L07138212P0A0
R260	RES 1K 0.1W ±2% 0805	L07131022P0A0
R261	RES 4R7 0.1W ±2% 0805	L07134722P0A0
R262	RES 10R 0.1W ±2% 0805	L07131002P0A0
R263	RES 100R 0.1W ±2% 0805	L07131012P0A0
R264	RES 4K7 0.1W ±2% 0805	L07134722P0A0
R265	RES 2K2 0.1W ±2% 0805	L07132222P0A0
R266	RES 1K 0.1W ±2% 0805	L07131022P0A0
R267	RES 100R 0.1W ±2% 0805	L07131012P0A0
R269	RES 330R 0.1W ±2% 0805	L07133312P0A0
R270	RES 18R 0.1W ±2% 0805	L07131802P0A0
R271	RES 330R 0.1W ±2% 0805	L07133312P0A0
R272	RES 51R 0.1W ±2% 0805	L07135102P0A0
R273	RES 68R 0.1W ±2% 0805	L07136802P0A0
R274	RES 100R 0.1W ±2% 0805	L07131012P0A0
R275	RES 330R 0.1W ±2% 0805	L07133312P0A0
R276	RES 18R 0.1W ±2% 0805	L07131802P0A0
R277	RES 330R 0.1W ±2% 0805	L07133312P0A0
R278	RES 51R 0.1W ±2% 0805	L07135102P0A0
R279	RES 1K 0.1W ±2% 0805	L07131022P0A0
R280	RES 1K 0.1W ±2% 0805	L07131022P0A0
R281	RES 15K 0.1W ±2% 0805	L07131532P0A0
R282	RES 10R 0.1W ±2% 0805	L07131002P0A0
R283	RES 10R 0.1W ±2% 0805	L07131002P0A0
R284	RES 1K 0.1W ±2% 0805	L07131022P0A0
R285	RES 15K 0.1W ±2% 0805	L07131532P0A0
R286	RES 1K 0.1W ±2% 0805	L07131022P0A0
R287	RES 68R 0.1W ±2% 0805	L07136802P0A0
R288	RES 100R 0.1W ±2% 0805	L07131012P0A0
R289	RES 51R 0.1W ±2% 0805	L07135102P0A0



R290	RES 1K 0.1W ±2% 0805	L07131022P0A0
R291	RES 1K8 0.1W ±2% 0805	L07131822P0A0
R292	RES 1K8 0.1W ±2% 0805	L07131822P0A0
R293	2K0 SMD SINGLE TURN POT	L0719202XT4A0
R294	RES 15K 0.1W ±2% 0805	L07131532P0A0
R295	RES 10R 0.1W ±2% 0805	L07131002P0A0
R296	RES 10R 0.1W ±2% 0805	L07131002P0A0
R297	RES 1K 0.1W ±2% 0805	L07131022P0A0
R298	RES 15K 0.1W ±2% 0805	L07131532P0A0
R299	RES 330R 0.1W ±2% 0805	L07133312P0A0
R300	RES 18R 0.1W ±2% 0805	L07131802P0A0
R301	RES 330R 0.1W ±2% 0805	L07133312P0A0
R302	RES 33K 0.1W ±2% 0805	L07133332P0A0
R303	RES 33K 0.1W ±2% 0805	L07133332P0A0
R304	RES 47K 0.1W ±2% 0805	L07134732P0A0
R305	RES 47K 0.1W ±2% 0805	L07134732P0A0
R306	RES 1M0 0.1W ±2% 0805	L07131052P0A0
R307	RES 10K 0.1W ±2% 0805	L07131032P0A0
R308	RES 10K 0.1W ±2% 0805	L07131032P0A0
R309	RES 330R 0.1W ±2% 0805	L07133312P0A0
R310	RES 15K 0.1W ±2% 0805	L07131532P0A0
R311	RES 4K7 0.1W ±2% 0805	L07134722P0A0
R312	RES 10K 0.1W ±2% 0805	L07131032P0A0
R313	RES 10K 0.1W ±2% 0805	L07131032P0A0
R314	RES 330R 0.1W ±2% 0805	L07133312P0A0
R315	RES 120R 0.1W ±2% 0805	L07131212P0A0
R316	RES 51R 0.1W ±2% 0805	L07135102P0A0
R317	RES 120R 0.1W ±2% 0805	L07131212P0A0
R318	RES 330R 0.1W ±2% 0805	L07133312P0A0
R319	RES 4K7 0.1W ±2% 0805	L07134722P0A0
R320	RES 18R 0.1W ±2% 0805	L07131802P0A0
R321	RES 3K9 0.1W ±2% 0805	L07133922P0A0
R322	RES 330R 0.1W ±2% 0805	L07133312P0A0
R323	RES 4K7 0.1W ±2% 0805	L07134722P0A0
R324	RES 18R 0.1W ±2% 0805	L07131802P0A0
R326	RES 1K 0.1W ±2% 0805	L07131022P0A0
R327	RES 2K2 0.1W ±2% 0805	L07132222P0A0
R328	RES 10K 0.1W ±2% 0805	L07131032P0A0
R335	RES 390K 0.1W ±2% 0805	L07133942P0A0
R336	RES 390K 0.1W ±2% 0805	L07133942P0A0
R338	RES 470K 0.1W 2% 0805	L07134742P0A0
R339	RES 470K 0.1W 2% 0805	L07134742P0A0
R340	RES 100K 0.1W ±2% 0805	L07131042P0A0
R341	RES 100K 0.1W ±2% 0805	L07131042P0A0
R342	RES 0R0 0.1W 0805	L07130022P0A0
R345	RES 0R0 0.1W 0805	L07130022P0A0
R347	RES 0R0 0.1W 0805	L07130022P0A0
R348	RES 0R0 0.1W 0805	L07130022P0A0
R349	RES 0R0 0.1W 0805	L07130022P0A0
R350	RES 0R0 0.1W 0805	L07130022P0A0
R351	4R7 SM CHIP 0805 0.1W 5%	L07134725POA0
R352	4R7 SM CHIP 0805 0.1W 5%	L07134725POA0
R358	RES 51R 0.1W ±2% 0805	L07135102P0A0
SK1	10 X 2 SOCKET STRIP	L01310X2SKTA0
SK2	7 X 2 SOCKET STRIP	L01307X2SKTA0
T1	44nH TRANSFORMER [1812]	L0077P2998AA0
T2	44nH TRANSFORMER [1812]	L0077P2998AA0
T3	44nH TRANSFORMER [1812]	L0077P2998AA0
TR2	BC846A [SOT-23]	L060SBC846AA0
TR3	BC856A [SOT-23]	L060SBC856AA0
TR5	BC846A [SOT-23]	L060SBC846AA0
TR7	BC856A [SOT-23]	L060SBC856AA0
TR8	BFS17A [SOT-23]	L060SBFS17AA0



TR18	BFS17A [SOT-23]	L060SBFS17AA0
TR26	BFS17A [SOT-23]	L060SBFS17AA0
TR27	BC869 [SOT-89]	L060SBC869XA0
TR28	BC846A [SOT-23]	L060SBC846AA0
TR29	BC846A [SOT-23]	L060SBC846AA0
TR30	BFS17A [SOT-23]	L060SBFS17AA0
TR31	BFQ19 [SOT-89]	L060SBFQ19XA0
TR32	BFS17A [SOT-23]	L060SBFS17AA0



USA 220 Synthesiser Transmit

PCB Parts List

Document No: LM030401014

Issue 3.4

Reference	Description	Stock Number
C1	CAP SM ELECT 1uF 50V 20%	L067B105BEGA0
C2	CAP 100nF X7R ±10% 1206	L0674104AXGA0
C3	CAP SM ELECT 1uF 50V 20%	L067B105BEGA0
C4	CAP 100nF X7R ±10% 1206	L0674104AXGA0
C5	CAP SM ELEC 10uF 16V 20%	L067B106BECA0
C6	CAP 100pF NPO ±5% 0805	L06731015NGA0
C7	CAP 10nF X7R ±10% 0805	L0673103AXGA0
C8	CAP 2p2 NPO 0.1pF 0805	L067322ZDNXA0
C9	CAP 1p8 NPO 0.1pF 0805	L067318ZDNXA0
C10	CAP 2p2 NPO ±0.25p 0805	L067322ZCNGA0
C12	CAP 100pF NPO ±5% 0805	L06731015NGA0
C14	CAP 100pF NPO ±5% 0805	L06731015NGA0
C15	CAP 100pF NPO ±5% 0805	L06731015NGA0
C16	CAP 1nF X7R ±10% 0805	L0673102AXGA0
C17	CAP 1nF X7R ±10% 0805	L0673102AXGA0
C18	CAP 1nF X7R ±10% 0805	L0673102AXGA0
C19	CAP 4p7 NPO ±0.25p 0805	L067347ZCNGA0
C22	CAP 1nF X7R ±10% 0805	L0673102AXGA0
C23	CAP 1nF X7R ±10% 0805	L0673102AXGA0
C24	CAP 12pF NPO ±5% 0805	L06731205NGA0
C25	CAP 12pF NPO ±5% 0805	L06731205NGA0
C26	CAP 100pF NPO ±5% 0805	L06731015NGA0
C27	CAP 1nF X7R ±10% 0805	L0673102AXGA0
C28	CAP 330pF NPO ±5% 0805	L06733315NGA0
C29	CAP 10nF X7R ±10% 0805	L0673103AXGA0
C30	CAP SM ELEC 10uF 16V 20%	L067B106BECA0
C31	CAP 10nF X7R ±10% 0805	L0673103AXGA0
C33	CAP 1nF X7R ±10% 0805	L0673102AXGA0
C34	CAP 100nF X7R ±10% 1206	L0674104AXGA0
C35	CAP 100nF X7R ±10% 1206	L0674104AXGA0
C36	CAP 10nF X7R ±10% 0805	L0673103AXGA0
C37	CAP SM ELEC 10uF 16V 20%	L067B106BECA0
C38	CAP 100pF NPO ±5% 0805	L06731015NGA0
C39	CAP 100pF NPO ±5% 0805	L06731015NGA0
C40	CAP 1nF X7R ±10% 0805	L0673102AXGA0
C41	CAP 1nF NPO 5% 0805	L06731025NGA0
D1	BB515 [SOD-123]	L063SBB515XA0
H1	SYNTH SCREENING CAN NO.1	L004SYNSCN1A0
IC1	78L05 [SO-8]	L05778L05SXA0
IC2	78L05 [SO-8]	L05778L05SXA0
IC3	UPB585G [SO-8]	L057UPB585GA0
IC4	SP8715 [MP8]	L057SP8715SA0
IC5	NJ88C28 IG NPAS [N20]	L057S88C28SA0
IC6	BA15532F [SO-8]	L057S5532XXA0
L2	IND 39nH 5% [1008]	L06483935CXA0
L3	IND 39nH 5% [1008]	L06483935CXA0



L4	IND 1uH 10% [1008]	L06481050CXA0
PCB1	PCB SYNTHESISER	L001SYNPCBXC0
R1	RES 10R 0.1W ±2% 0805	L07131002POA0
R2	RES 18R 0.1W ±2% 0805	L07131802POA0
R3	RES 8K2 0.1W ±2% 0805	L07138222POA0
R4	RES 220R 0.1W ±2% 0805	L07132212POA0
R5	RES 10K 0.1W ±2% 0805	L07131032POA0
R6	RES 10K 0.1W ±2% 0805	L07131032POA0
R7	RES 4K7 0.1W ±2% 0805	L07134722POA0
R8	RES 220R 0.1W ±2% 0805	L07132212POA0
R9	RES 51R 0.1W ±2% 0805	L07135102POA0
R16	RES 4K7 0.1W ±2% 0805	L07134722POA0
R17	RES 10K 0.1W ±2% 0805	L07131032POA0
R18	RES 150R 0.1W ±2% 0805	L07131512POA0
R19	RES 10R 0.1W ±2% 0805	L07131002POA0
R20	RES 22K 0.1W ±2% 0805	L07132232POA0
R21	RES 330K 0.1W 2% 0805	L07133342POA0
R22	RES 2K2 0.1W ±2% 0805	L07132222POA0
R23	RES 10K 0.1W ±2% 0805	L07131032POA0
R24	RES 10K 0.1W ±2% 0805	L07131032POA0
R25	RES 10K 0.1W ±2% 0805	L07131032POA0
R26	RES 10K 0.1W ±2% 0805	L07131032POA0
R27	RES 10R 0.1W ±2% 0805	L07131002POA0
R29	RES 1K 0.1W ±2% 0805	L07131022POA0
R30	RES 100R 0.1W ±2% 0805	L07131012POA0
R31	RES 91R 0.1W ±2% 0805	L07139102POA0
R32	RES 82R 0.1W ±2% 0805	L07138202POA0
R33	RES 91R 0.1W ±2% 0805	L07139102POA0
R34	RES 0R0 0.1W 0805	L07130022POA0
SK1	025 MINI SPRING SOCKET	L013025CCXXA0
SK2	025 MINI SPRING SOCKET	L013025CCXXA0
SK3	025 MINI SPRING SOCKET	L013025CCXXA0
SK4	025 MINI SPRING SOCKET	L013025CCXXA0
SK5	025 MINI SPRING SOCKET	L013025CCXXA0
SK6	025 MINI SPRING SOCKET	L013025CCXXA0
SK7	025 MINI SPRING SOCKET	L013025CCXXA0
SK8	025 MINI SPRING SOCKET	L013025CCXXA0
SK9	025 MINI SPRING SOCKET	L013025CCXXA0
SK10	025 MINI SPRING SOCKET	L013025CCXXA0
SK11	025 MINI SPRING SOCKET	L013025CCXXA0
SK12	025 MINI SPRING SOCKET	L013025CCXXA0
TL1	1000MHz RESONATOR (SM)	L055RES102AA0
TR1	BFR92A [SOT 23]	L060SBFR92AA0
TR2	BFR92A [SOT 23]	L060SBFR92AA0



USA 220 Signal Processing Unit Exciter

Software Parts List

Document No: LM030501003

Issue 1.0

Reference	Description	Stock Number
U23	S/W SPU EXCITER U23 LOW	L058SPUEU23A0
U24	S/W SPU EXCITER U24 HIGH	L058SPUEU24A0

PCB Parts List

Document No: LM030400002

Issue 1.2

Reference	Description	Stock Number
C2	CAP 47pF NPO 5% 0805	L06734705NBA0
C3	CAP 100n 2F4 / X7R 0805	L0673104A2BA0
C4	CAP 100n 2F4 / X7R 0805	L0673104A2BA0
C5	CAP 100n 2F4 / X7R 0805	L0673104A2BA0
C6	CAP 100n 2F4 / X7R 0805	L0673104A2BA0
C7	CAP 100n 2F4 / X7R 0805	L0673104A2BA0
C8	CAP 100n 2F4 / X7R 0805	L0673104A2BA0
C9	CAP 100n 2F4 / X7R 0805	L0673104A2BA0
C10	CAP 100n 2F4 / X7R 0805	L0673104A2BA0
C11	CAP 100n 2F4 / X7R 0805	L0673104A2BA0
C12	CAP 100n 2F4 / X7R 0805	L0673104A2BA0
C13	CAP 100n 2F4 / X7R 0805	L0673104A2BAC
C14	CAP 100n 2F4 / X7R 0805	L0673104A2BA0
C15	CAP 100n 2F4 / X7R 0805	L0673104A2BA0
C16	CAP 100n 2F4 / X7R 0805	L0673104A2BA0
C17	CAP 100n 2F4 / X7R 0805	L0673104A2BA0
C18	CAP 100n 2F4 / X7R 0805	L0673104A2BA0
C19	CAP 100n 2F4 / X7R 0805	L0673104A2BAC
C20	CAP 100n 2F4 / X7R 0805	L0673104A2BAC
C21	CAP 100n 2F4 / X7R 0805	L0673104A2BAC
C22	CAP 100n 2F4 / X7R 0805	L0673104A2BAC
C24	CAP 10pF NPO ±10% 0805	L0673100ANBAC
C29	CAP 100nF X7R ±10% 0805	L0673104AXBAC
C30	CAP 3n3 X7R 10% 1206	L0674332AXBAC
C31	CAP 3n3 X7R 10% 1206	L0674332AXBAC
C32	CAP 10nF X7R ±10% 0805	L0673103AXBAC
C33	CAP 10nF X7R ±10% 0805	L0673103AXBAC
C34	CAP 10nF X7R ±10% 0805	L0673103AXBAC
C35	CAP 10nF X7R ±10% 0805	L0673103AXBAC
C39	CAP 100nF X7R ±10% 0805	L0673104AXBAC
C40	CAP 100nF X7R ±10% 0805	L0673104AXBAC
C41	CAP 100nF X7R ±10% 0805	L0673104AXBAC
C42	CAP 100nF X7R ±10% 0805	L0673104AXBAC
C43	CAP SM ELEC 10uF 16V 20%	L067B106BECA0
C44	CAP SM ELEC 10uF 16V 20%	L067B106BECA0
C45	CAP 470nF 10% X7R 1812	L0677474AXBAC



C46	CAP 100nF X7R 10% 1206	L0674104AXBAA
C47	CAP SM ELECT 1uF 50V 20%	L067B105BEGA0
C48	CAP 100nF X7R ±10% 0805	L0673104AXBAA
C51	CAP 47pF X7R 10% 0805	L0673470AXBAA
C52	CAP 47pF X7R 10% 0805	L0673470AXBAA
C59	CAP 100pF NPO ±10% 0805	L0673101ANBAA
C76	CAP SM ELECT 1uF 50V 20%	L067B105BEGA0
C77	CAP SM ELECT 1uF 50V 20%	L067B105BEGA0
C87	CAP 100pF NPO ±10% 0805	L0673101ANBAA
C88	CAP 100pF NPO ±10% 0805	L0673101ANBAA
C99	CAP 100nF X7R ±10% 0805	L0673104AXBAA
C101	CAP 100nF X7R ±10% 1206	L0674104AXGAA
C102	CAP 1nF X7R ±10% 0805	L0673102AXBAA
C103	CAP ELECT 82uF 25V 20%	L066PL1E820A0
C104	CAP ELECT 82uF 25V 20%	L066PL1E820A0
C105	CAP 4n7 X7R ±10% 1206	L0674472AXBAA
C106	CAP ELECT 27uF 35V 20%	L066PL1V270A0
C107	CAP ELECT 27uF 35V 20%	L066PL1V270A0
C108	CAP 100nF X7R ±10% 0805	L0673104AXEAA
C109	CAP ELECT 120uF 16V 20%	L066PL1C121A0
C110	CAP ELECT 330uF 10V 20%	L066PL1A331A0
C111	CAP ELECT 180uF 10V 20%	L066PL1A181A0
C112	CAP 1nF X7R ±10% 0805	L0673102AXBAA
C113	CAP 1nF X7R ±10% 0805	L0673102AXBAA
C114	CAP 100nF X7R ±10% 0805	L0673104AXBAA
C115	CAP 10nF X7R ±10% 0805	L0673103AXBAA
C116	CAP ELECT 1200uF 25V 20%	L066PL1E122A0
C117	CAP ELECT 270uF 16V 20%	L066PL1C271A0
C118	CAP 100nF X7R ±10% 0805	L0673104AXBAA
C119	CAP ELECT 56uF 16V 20%	L066PL1C560A0
C120	CAP ELECT 56uF 16V 20%	L066PL1C560A0
C121	CAP ELECT 56uF 16V 20%	L066PL1C560A0
C122	CAP ELECT 56uF 16V 20%	L066PL1C560A0
C123	CAP 2n2 X7R ±10% 1206	L0674222AXHAA
C124	CAP 100nF X7R ±10% 0805	L0673104AXBAA
D1	BAS16 [SOT 23]	L063SBAS16XAA
D2	BAS16 [SOT 23]	L063SBAS16XAA
D6	BYV27-100 [SOD-57]	L063LBYV27SAA
D7	BAS32 [SOD-80]	L063SBAS32XAA
D8	BAS32 [SOD-80]	L063SBAS32XAA
D9	BAS32 [SOD-80]	L063SBAS32XAA
D10	BZX84C12 [SOT-23]	L063SBZX84SAA
D11	DE5SC4M [SM DE5]	L063DE5SC4MAA
D12	BAS32 [SOD-80]	L063SBAS32XAA
D13	BYV27-100 [SOD-57]	L063LBYV27SAA
D14	BYV27-100 [SOD-57]	L063LBYV27SAA
D15	BYV27-100 [SOD-57]	L063LBYV27SAA
D16	LDP24A	L063LDP24AXAA
F1	FUSE 10A (SMD)	L07210ASMD1A0
J3	AVDEL AVSERT M2.5 X 5mm	L0131176555A0
J4	AVDEL AVSERT M2.5 X 9mm	L0131176590A0
L1	22uH INDUCTOR	L06420UHLXXAA
L2	22uH INDUCTOR	L06420UHLXXAA
L3	22uH INDUCTOR	L06420UHLXXAA
L4	22uH LOW ESR CHOKE	L06422UHSM2A0
L5	22uH LOW ESR CHOKE	L06422UHSM2A0
L6	22uH LOW ESR CHOKE	L06422UHSM2A0
L7	22uH LOW ESR CHOKE	L06422UHSM2A0
L8	22uH LOW ESR CHOKE	L06422UHSM2A0
PCB1	SPU PCB	L001SPUPCBXC0
PL1	10 X 2 SHROUDED T/S SLIM	L01310X2PHSA0
PL2	7 X 2 SHROUDED T/S SLIM	L01307X2PHSA0
Q2	BUK555-100B TO220	L060LBUK555A0



Q3	BC846A [SOT-23]	L060SBC846AA0
Q4	BC807 [SOT-23]	L060SBC807XA0
R1	RES 1K 0.1W ±2% 0805	L07131022P0A0
R2	RES 1K 0.1W ±2% 0805	L07131022P0A0
R4	RES 10K 0.1W ±2% 0805	L07131032P0A0
R5	RES 10K 0.1W ±2% 0805	L07131032P0A0
R6	RES 1K 0.1W ±2% 0805	L07131022P0A0
R7	RES 1K 0.1W ±2% 0805	L07131022P0A0
R8	RES 1K 0.1W ±2% 0805	L07131022P0A0
R12	RES 620R 0.1W ±2% 0805	L07136212P0A0
R13	RES 10K 0.1W ±2% 0805	L07131032P0A0
R14	RES 10K 0.1W ±2% 0805	L07131032P0A0
R15	RES 10K 0.1W ±2% 0805	L07131032P0A0
R16	RES 1K 0.1W ±2% 0805	L07131022P0A0
R17	RES 1K 0.1W ±2% 0805	L07131022P0A0
R18	RES 1K 0.1W ±2% 0805	L07131022P0A0
R19	RES 1K 0.1W ±2% 0805	L07131022P0A0
R20	RES 51R 0.1W ±2% 0805	L07135102P0A0
R21	RES 10K 0.1W ±2% 0805	L07131032P0A0
R22	RES 300R 0.1W ±2% 0805	L07133012P0A0
R23	RES 300R 0.1W ±2% 0805	L07133012P0A0
R25	RES 1K5 0.1W ±2% 0805	L07131522P0A0
R26	RES 330R 0.1W ±2% 0805	L07133312P0A0
R27	RES 330R 0.1W ±2% 0805	L07133312P0A0
R28	RES 10K 0.1W ±2% 0805	L07131032P0A0
R29	RES 10K 0.1W ±2% 0805	L07131032P0A0
R30	RES 300R 0.1W ±2% 0805	L07133012P0A0
R31	RES 300R 0.1W ±2% 0805	L07133012P0A0
R32	RES 1K5 0.1W ±2% 0805	L07131522P0A0
R33	RES 1K5 0.1W ±2% 0805	L07131522P0A0
R34	RES 33R 0.1W ±2% 0805	L07133302P0A0
R35	RES 33R 0.1W ±2% 0805	L07133302P0A0
R36	RES 1K5 0.1W ±2% 0805	L07131522P0A0
R39	RES 10K 0.1W ±2% 0805	L07131032P0A0
R40	RES 10K 0.1W ±2% 0805	L07131032P0A0
R41	RES 10K 0.1W ±2% 0805	L07131032P0A0
R42	RES 10K 0.1W ±2% 0805	L07131032P0A0
R43	RES 10K 0.1W ±2% 0805	L07131032P0A0
R44	RES 10K 0.1W ±2% 0805	L07131032P0A0
R45	RES 620R 0.1W ±2% 0805	L07136212P0A0
R46	RES 10K 0.1W ±2% 0805	L07131032P0A0
R47	RES 10K 0.1W ±2% 0805	L07131032P0A0
R48	RES 10K 0.1W ±2% 0805	L07131032P0A0
R49	RES 10K 0.1W ±2% 0805	L07131032P0A0
R50	RES 10K 0.1W ±2% 0805	L07131032P0A0
R51	RES 10K 0.1W ±2% 0805	L07131032P0A0
R52	RES 10K 0.1W ±2% 0805	L07131032P0A0
R53	RES 10K 0.1W ±2% 0805	L07131032P0A0
R54	RES 10K 0.1W ±2% 0805	L07131032P0A0
R66	RES 100K 0.1W ±2% 0805	L07131042P0A0
R67	RES 100K 0.1W ±2% 0805	L07131042P0A0
R68	RES 3K6 0.1W ±2% 0805	L07133622P0A0
R72	RES 120K 0.1W ±2% 0805	L07131242P0A0
R73	RES 1K8 0.1W ±2% 0805	L07131822P0A0
R75	RES 620R 0.1W ±2% 0805	L07136212P0A0
R84	RES 270K 0.1W ±2% 0805	L07132742P0A0
R85	RES 56K 0.1W ±2% 0805	L07135632P0A0
R86	RES 150K 0.1W ±2% 0805	L07131542P0A0
R90	RES 0R0 0.1W 0805	L071300Z2P0A0
R94	RES 1M0 0.1W ±2% 0805	L07131052P0A0
R95	RES 1M0 0.1W ±2% 0805	L07131052P0A0
R96	RES 1M0 0.1W ±2% 0805	L07131052P0A0
R98	RES 10K 0.1W ±2% 0805	L07131032P0A0



R99	RES 10K 0.1W ±2% 0805	L07131032P0A0
R104	RES 100K 0.1W ±2% 0805	L07131042P0A0
R106	RES 100K 0.1W ±2% 0805	L07131042P0A0
R107	RES 100K 0.1W ±2% 0805	L07131042P0A0
R108	RES 100K 0.1W ±2% 0805	L07131042P0A0
R113	RES 10R 0.125W ±2% 1206	L07141002P4A0
R114	RES 100R 0.1W ±2% 0805	L07131012P0A0
R115	RES 3K9 0.1W ±2% 0805	L07133922P0A0
R116	RES 22K 0.1W ±2% 0805	L07132232P0A0
R117	RES 12R 0.125W ±2% 1206	L07141202P4A0
R118	RES 0R0 0.1W 0805	L07130022P0A0
R119	RES 15K 0.125W ±2% 1206	L07141532P4A0
R120	RES 10K 0.1W ±2% 0805	L07131032P0A0
R121	RES 22K 0.1W ±2% 0805	L07132232P0A0
R122	RES 1K0 0.125W ±1% 1206	L07141021P4A0
R123	RES 56K 0.1W ±2% 0805	L07135632P0A0
R124	RES 100K 0.1W ±2% 0805	L07131042P0A0
R125	RES 15K 0.1W ±2% 0805	L07131532P0A0
R126	RES 2K7 0.1W ±2% 0805	L07132722P0A0
R127	RES 27K 0.1W ±2% 0805	L07132732P0A0
R128	RES 22R 0.125W ±2% 1206	L07142202P8A0
R129	RES 1K0 0.125W ±1% 1206	L07141021P4A0
R130	RES 270R 0.425W ±5% 1210	L07152715PBA0
R131	RES 270R 0.425W ±5% 1210	L07152715PBA0
R132	RES 0R1 2.5W 10%	L069W210R1XA0
R133	RES 8K2 0.1W ±2% 0805	L07138222P0A0
R134	RES 68K 0.1W ±2% 0805	L07136832P0A0
R135	RES 2K2 0.125W ±2% 1206	L07142222P4A0
R136	RES 3K9 0.1W ±2% 0805	L07133922P0A0
R137	RES 330R 0.1W ±2% 0805	L07133312P0A0
R138	RES 3K9 0.1W ±2% 0805	L07133922P0A0
R154	RES 10K 0.1W ±2% 0805	L07131032P0A0
R157	RES 10K 0.1W ±2% 0805	L07131032P0A0
R160	RES 10K 0.1W ±2% 0805	L07131032P0A0
R161	RES 150K 0.1W ±2% 0805	L07131542P0A0
R162	RES 620R 0.1W ±2% 0805	L07136212P0A0
R163	RES 620R 0.1W ±2% 0805	L07136212P0A0
R174	RES 1K 0.1W ±2% 0805	L07131022P0A0
R175	RES 1K 0.1W ±2% 0805	L07131022P0A0
R176	RES 1K 0.1W ±2% 0805	L07131022P0A0
R177	RES 1K 0.1W ±2% 0805	L07131022P0A0
R178	RES 1K 0.1W ±2% 0805	L07131022P0A0
R179	RES 1K 0.1W ±2% 0805	L07131022P0A0
R180	RES 1K 0.1W ±2% 0805	L07131022P0A0
R181	RES 1K 0.1W ±2% 0805	L07131022P0A0
R182	RES 1K 0.1W ±2% 0805	L07131022P0A0
R183	RES 1K 0.1W ±2% 0805	L07131022P0A0
R184	RES 1K 0.1W ±2% 0805	L07131022P0A0
R185	RES 1K 0.1W ±2% 0805	L07131022P0A0
R186	RES 1K 0.1W ±2% 0805	L07131022P0A0
R189	RES 0R0 0.1W 0805	L07130022P0A0
SK1	8 X 2 SHROUDED T/STRIP	L01308X2PHSA0
SK2	8 X 2 PIN HEADER	L01308X2TSXA0
SK3	32 PIN PLCC EPROM SOCKET	L01332PLCCSA0
SK4	32 PIN PLCC EPROM SOCKET	L01332PLCCSA0
T1	EDF20 TRANSFORMER CUSTOM	L007ABTRAN8A0
U10	LMC660AIM [SO-14]	L057LMC660MA0
U11	LMC660AIM [SO-14]	L057LMC660MA0
U12	TLC274ID [SO-14]	L057TLC274XA0
U14	TLC274ID [SO-14]	L057TLC274XA0
U15	LMC660AIM [SO-14]	L057LMC660MA0
U16	TMS320C25FNA 68 PIN PLCC	L057320C25XA0
U17	EDI8834C35MI [28PIN SOJ]	L057ED34C35A0



U18	EDI8834C35MI [28PIN SOJ]	L057ED34C35A0
U19	74HCT273 [SO-20W]	L057HCT273TA0
U20	74HCT273 [SO-20W]	L057HCT273TA0
U21	SOFTWARE [PAL]	L05720V8H55A0
U22	PCD8584T [SO-20W]	L057PCD8584A0
U25	39.32160MHz OSC 4 PIN	L055X39M321A0
U26	74HCT273 [SO-20W]	L057HCT273TA0
U27	74HCT125 [SO-14]	L057HCT125SA0
U28	MAX699EWE [SO-16W]	L057MAX699EA0
U29	1020A FPGA [PLCC-68]	L057FPGABLVA0
U30	TDA1544SO [SO-16W]	L057TDA1544A0
U31	TDA1544SO [SO-16W]	L057TDA1544A0
U32	CS5349-BS [SO-28W]	L057CS5349BA0
U33	74HCT4053 [SO-16]	L057HCT4053A0
U36	74HCT4053 [SO-16]	L057HCT4053A0
U38	4093 [SO-14]	L0574093BTXA0
U39	UC2845N [8-PIN DIL]	L057UC2845AA0
U40	78L05 [SO-8]	L05778L05SXA0



Radio Frequency Unit Exciter v4.3

Top View

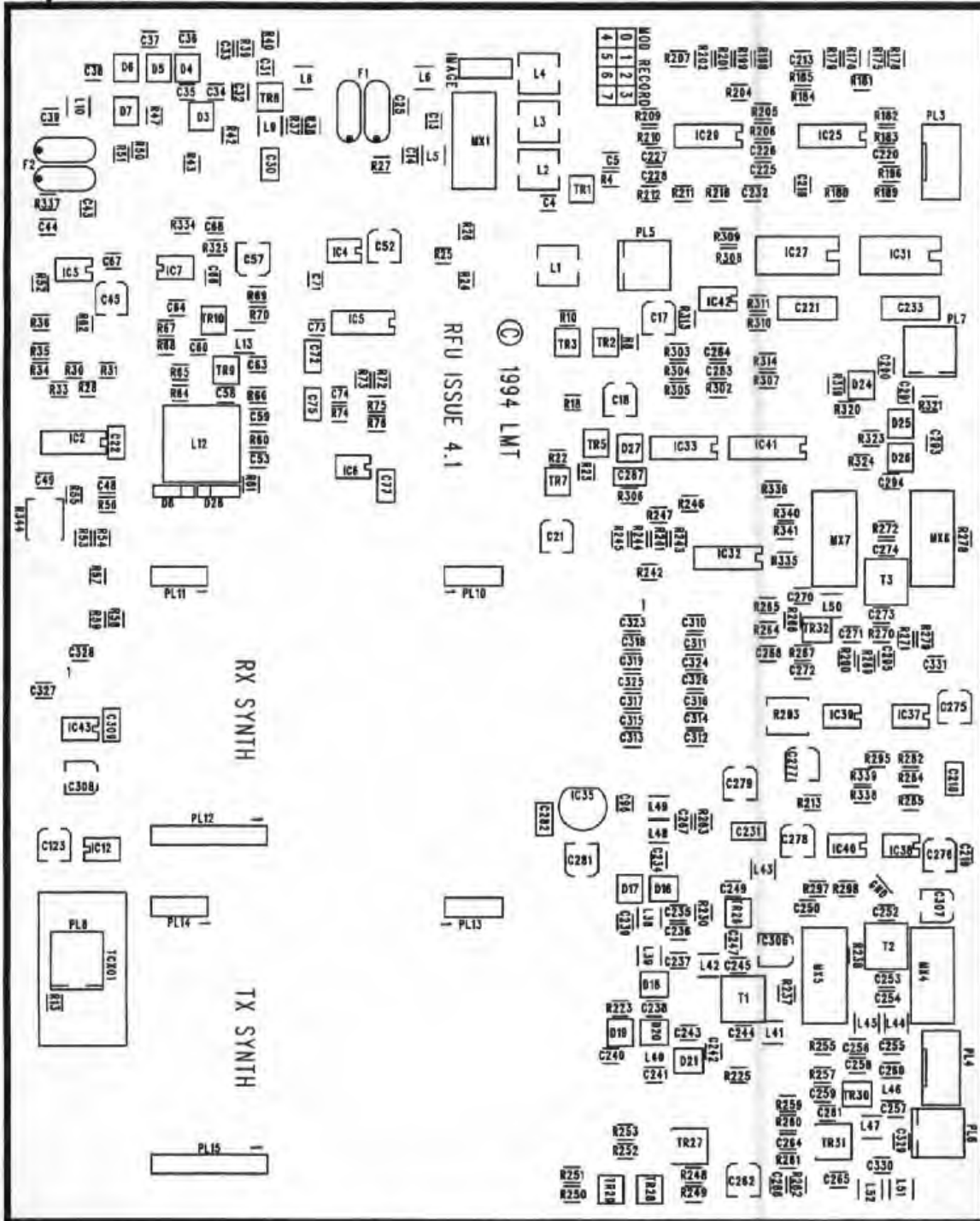

SECURICOR - LMT LTD
RFU BOARD ISSUE 4.1



Bottom View

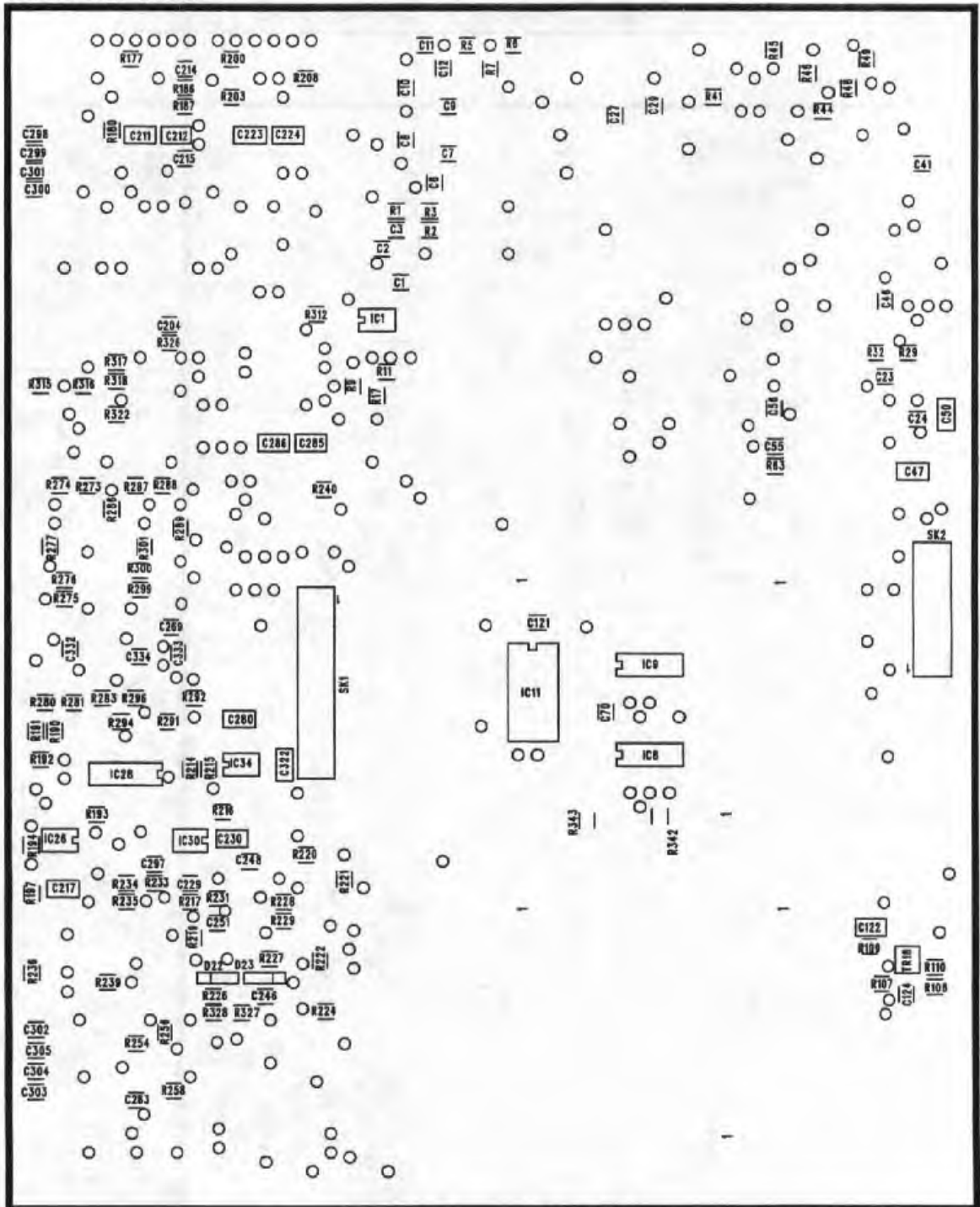

SECURICOR - LMT LTD
 RFU BOARD ISSUE 4.1
 SILK SCREEN BOTTOM



Radio Frequency Unit Exciter/Receiver v5.2

Top View

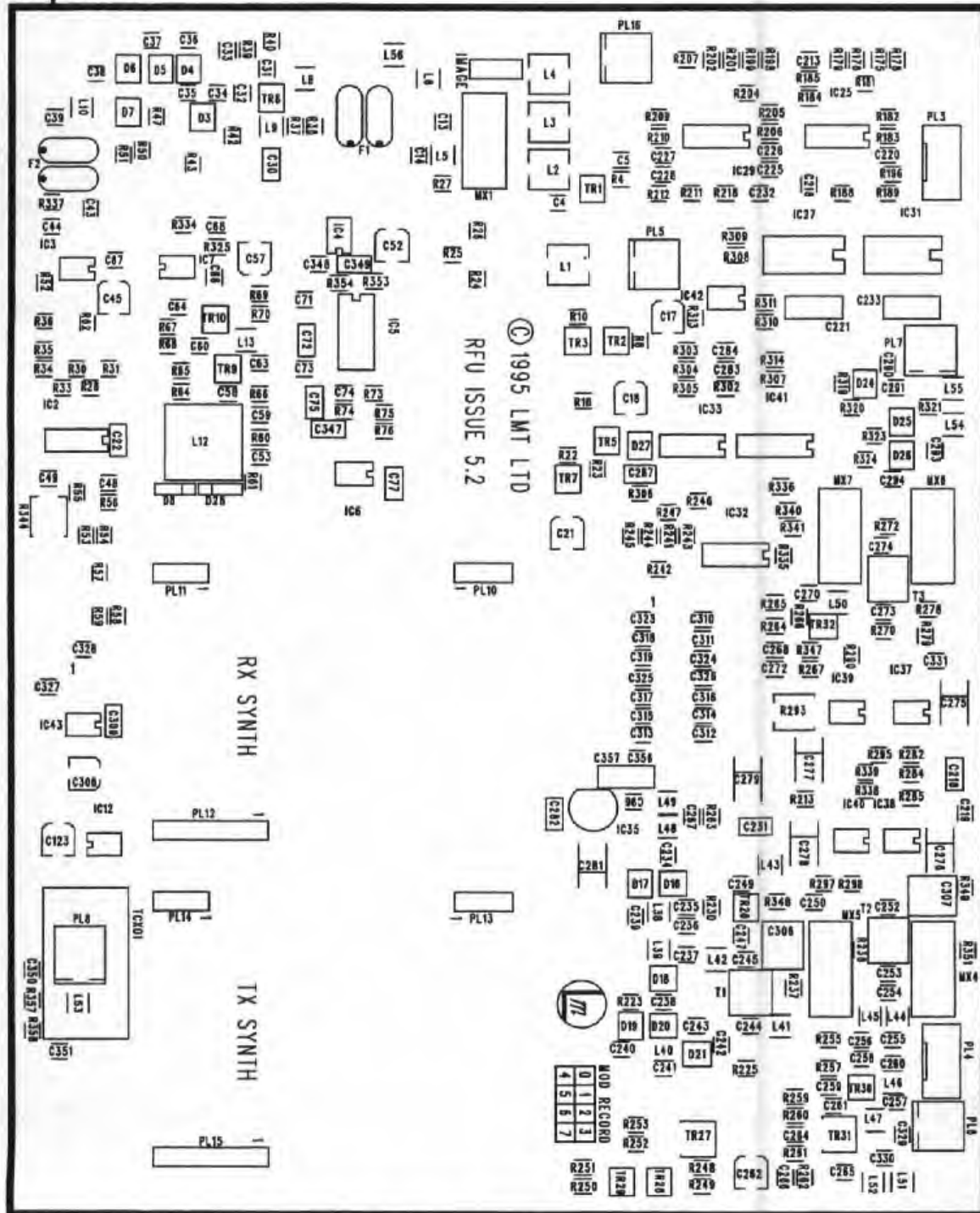

SECURICOR - LMT LTD
RFU BOARD ISSUE 5.2
SILK SCREEN TOP



Bottom View



SECURICOR - LMT LTD
RFU BOARD ISSUE 2.5
SILK SCREEN BOTTOM



Synthesiser Transmit

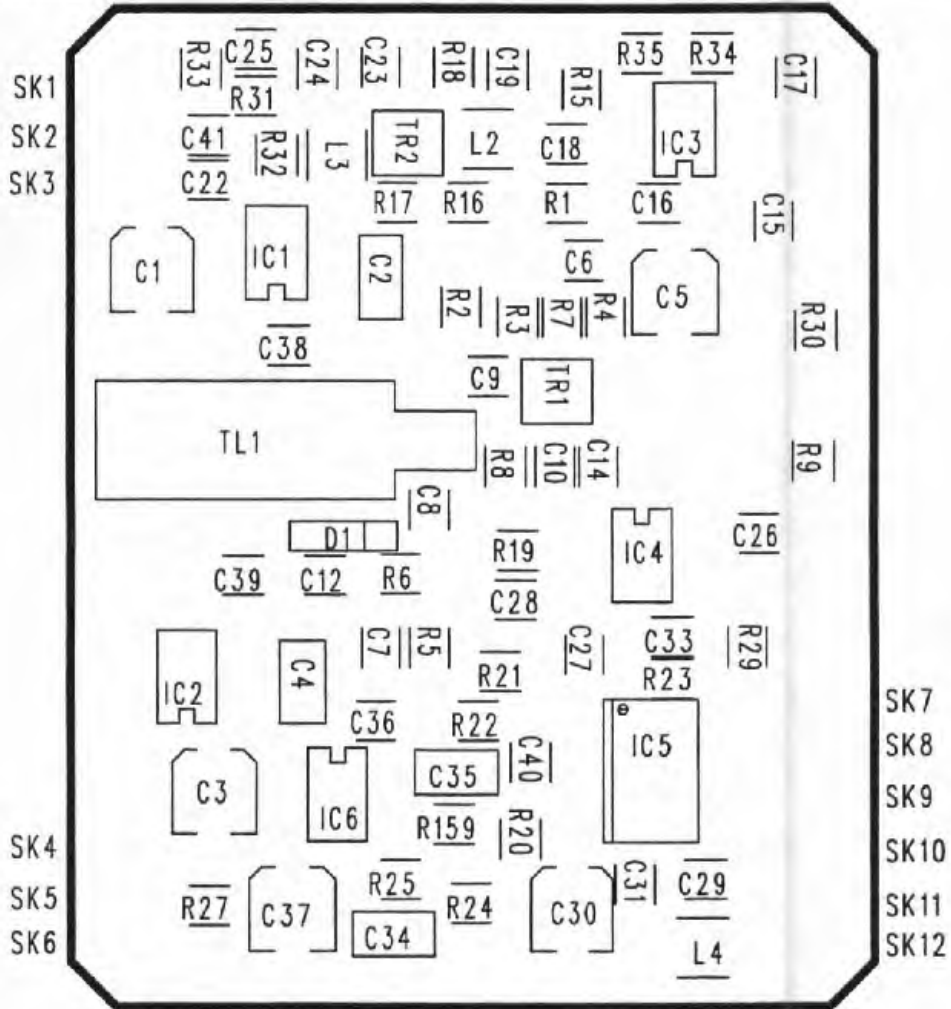

LINEAR MODULATION TECHNOLOGY
SYNTHESISER PCB VER 3.2



Signal Processing Unit Exciter

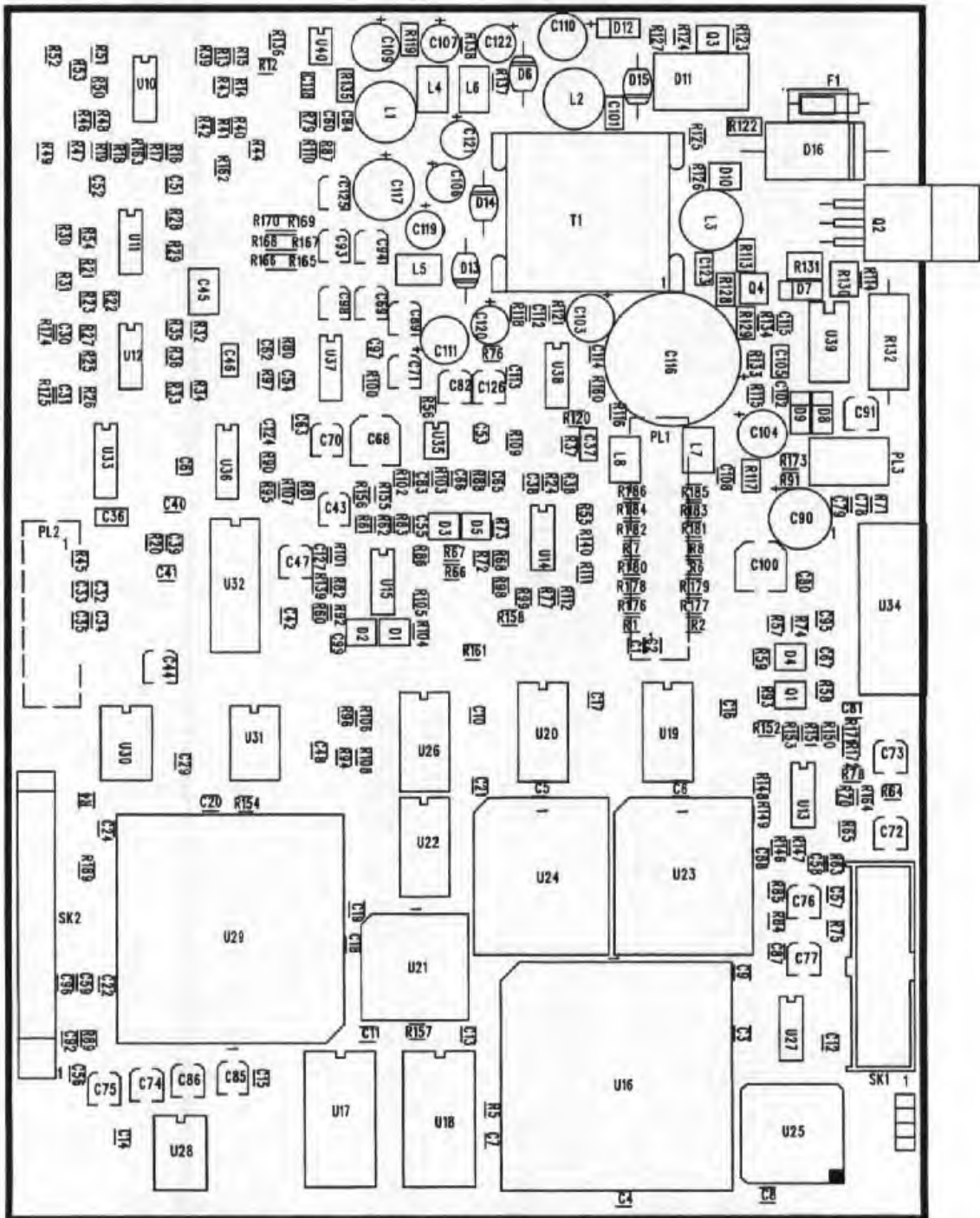

SECURICOR ELECTRONICS - LMT LTD
SPU BOARD ISSUE 2.5

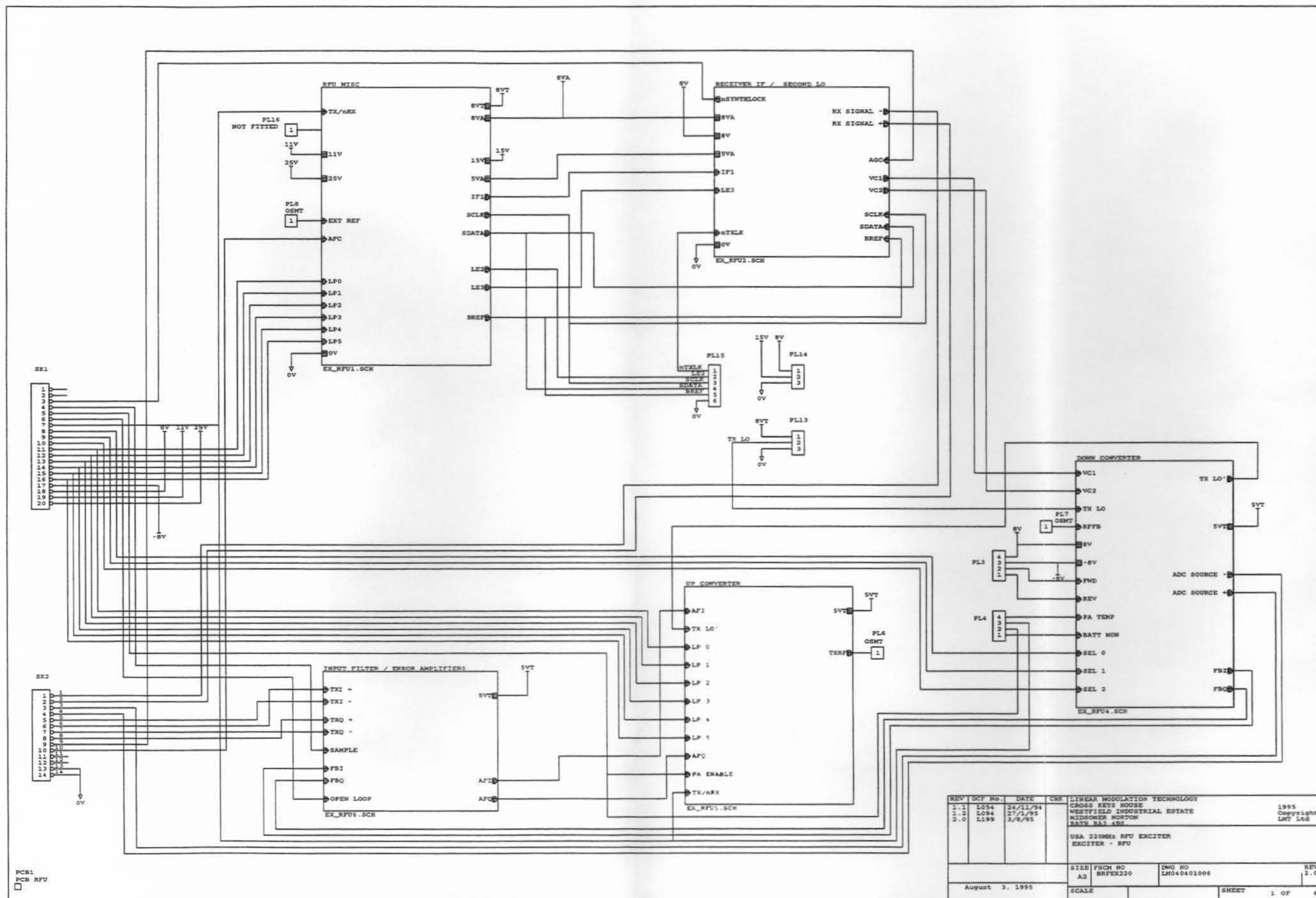

REV	DCF No.	DATE	CHK	LINEAR MODULATION TECHNOLOGY	1995
1.1	L054	24/11/94		CROSS KEYS HOUSE	Copyright
1.2	L084	27/1/95		WESTFIELD INDUSTRIAL ESTATE	LMT Ltd
2.0	L199	3/8/95		MIDSOMER NORTON	
				BATH BA1 4BE	
USA 220MHz RFU EXCITER					
EXCITER - RFU					
				SIZE	REV
				A2	3.0
August 3, 1995				DWG NO	
				LM040401006	
				SCALE	SHEET
					1 OF 6

PCB1
PCB RFU

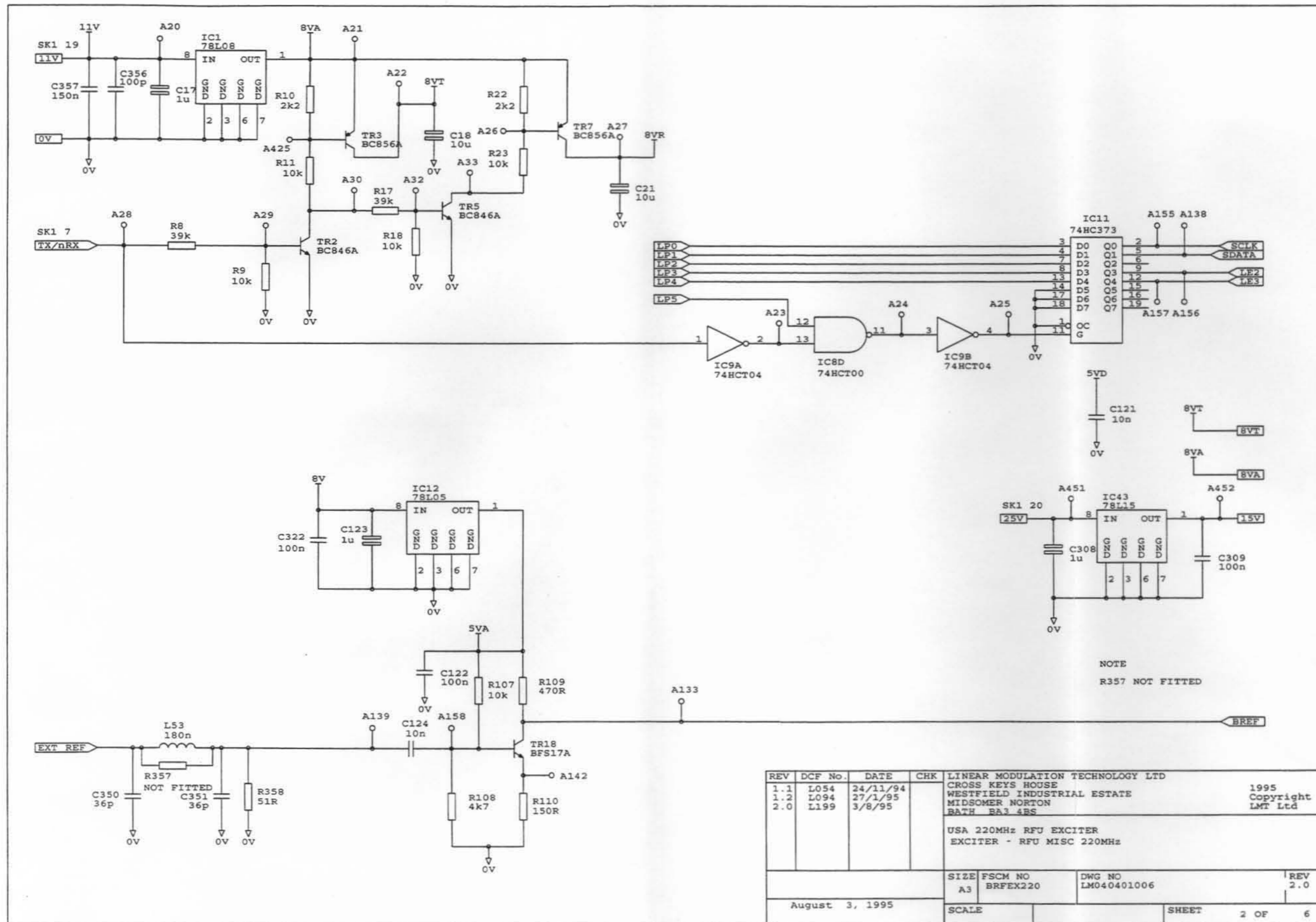

REV	DCF No.	DATE	CHK	LINEAR MODULATION TECHNOLOGY LTD CROSS KEYS HOUSE WESTFIELD INDUSTRIAL ESTATE MIDSOMER NORTON BATH BA3 4RS	1995 Copyright LMT Ltd
1.1	L054	24/11/94			
1.2	L094	27/1/95			
2.0	L199	3/8/95			
				USA 220MHz RFU EXCITER EXCITER - RFU MISC 220MHz	
				SIZE A3	FSCM NO BRFEX220
				DWG NO LM040401006	REV 2.0
August 3, 1995				SCALE	SHEET 2 OF 6

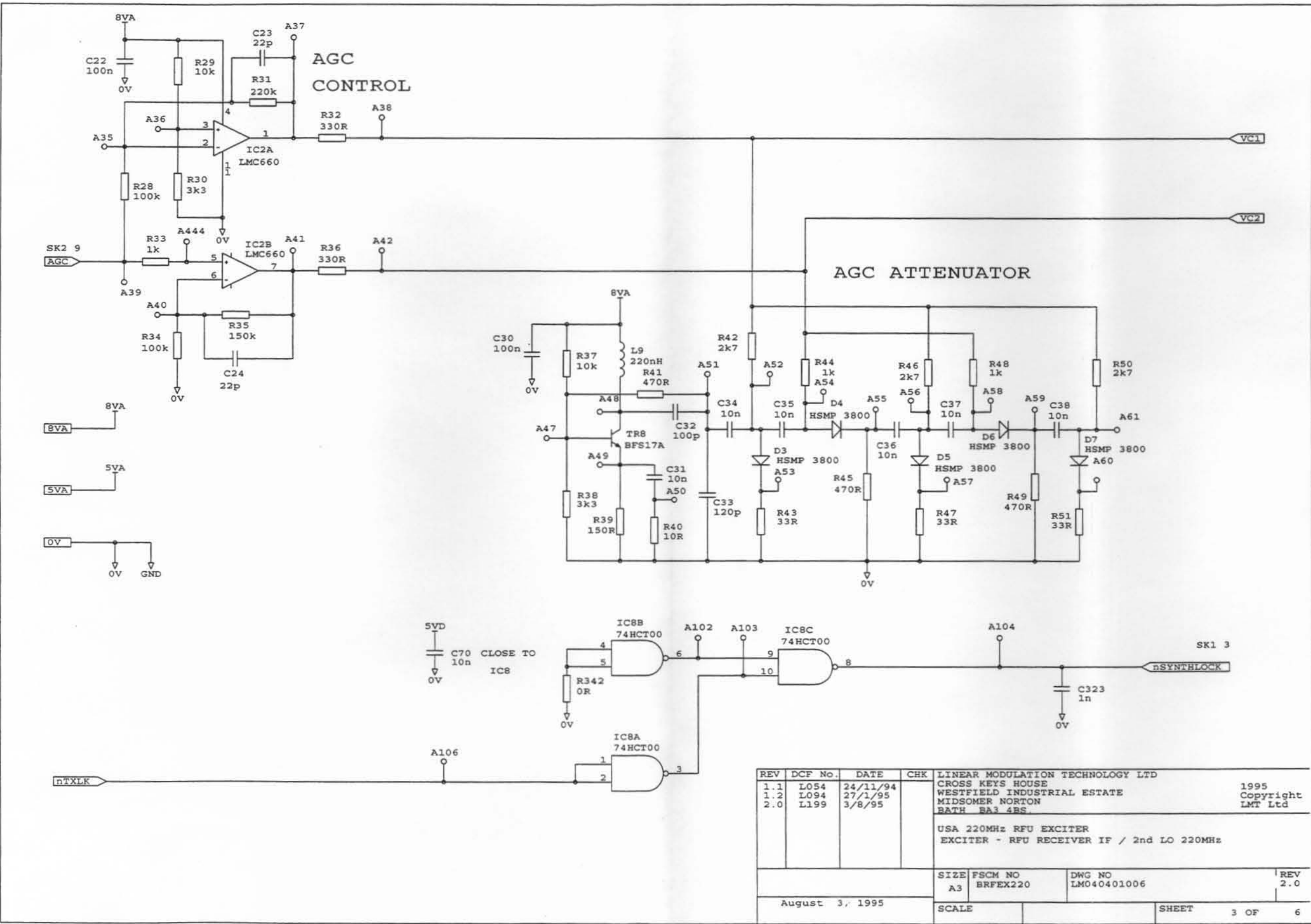

REV	DCF No.	DATE	CHK	LINEAR MODULATION TECHNOLOGY LTD CROSS KEYS HOUSE WESTFIELD INDUSTRIAL ESTATE MIDSOMER NORTON BATH BA3 4RS.	1995 Copyright LMT Ltd
1.1	L054	24/11/94			
1.2	L094	27/1/95			
2.0	L199	3/8/95			
				USA 220MHz RFU EXCITER EXCITER - RFU RECEIVER IF / 2nd LO 220MHz	
		SIZE A3	FSCM NO BRFEX220	DWG NO LM040401006	REV 2.0
August 3, 1995		SCALE		SHEET	3 OF 6

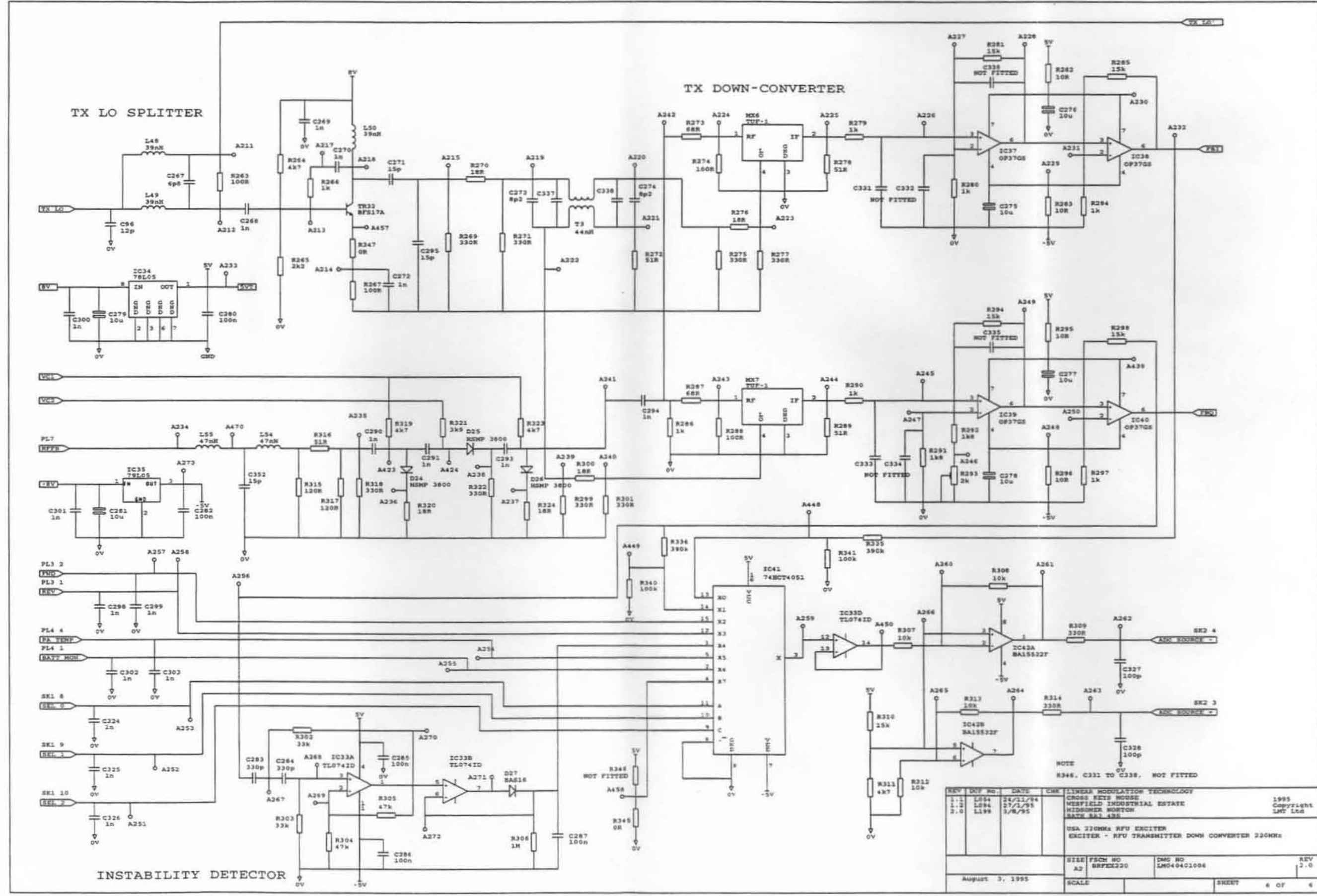

REV	IMP NO.	DATE	CHK	DESCRIPTION	REV
1.1	L184	24/11/94		LINEAR MODULATION TECHNOLOGY	1995
1.2	L184	27/11/94		CH008 EITS HOUSE	Copyright
2.0	L199	3/8/95		MESFIELD INDUSTRIAL ESTATE	LM Ltd
				WIDENHURST WORTON	
				WATE BA3 438	
USA 230MHz RFU EXCITER					
EXCITER - RFU TRANSMITTER DOWN CONVERTER 230MHz					
SIZE		PCB NO	DWG NO	REV	
A2		BRF0220	LM040C1006	2.0	
August 3, 1995					
SCALE				SHEET 4 OF 6	

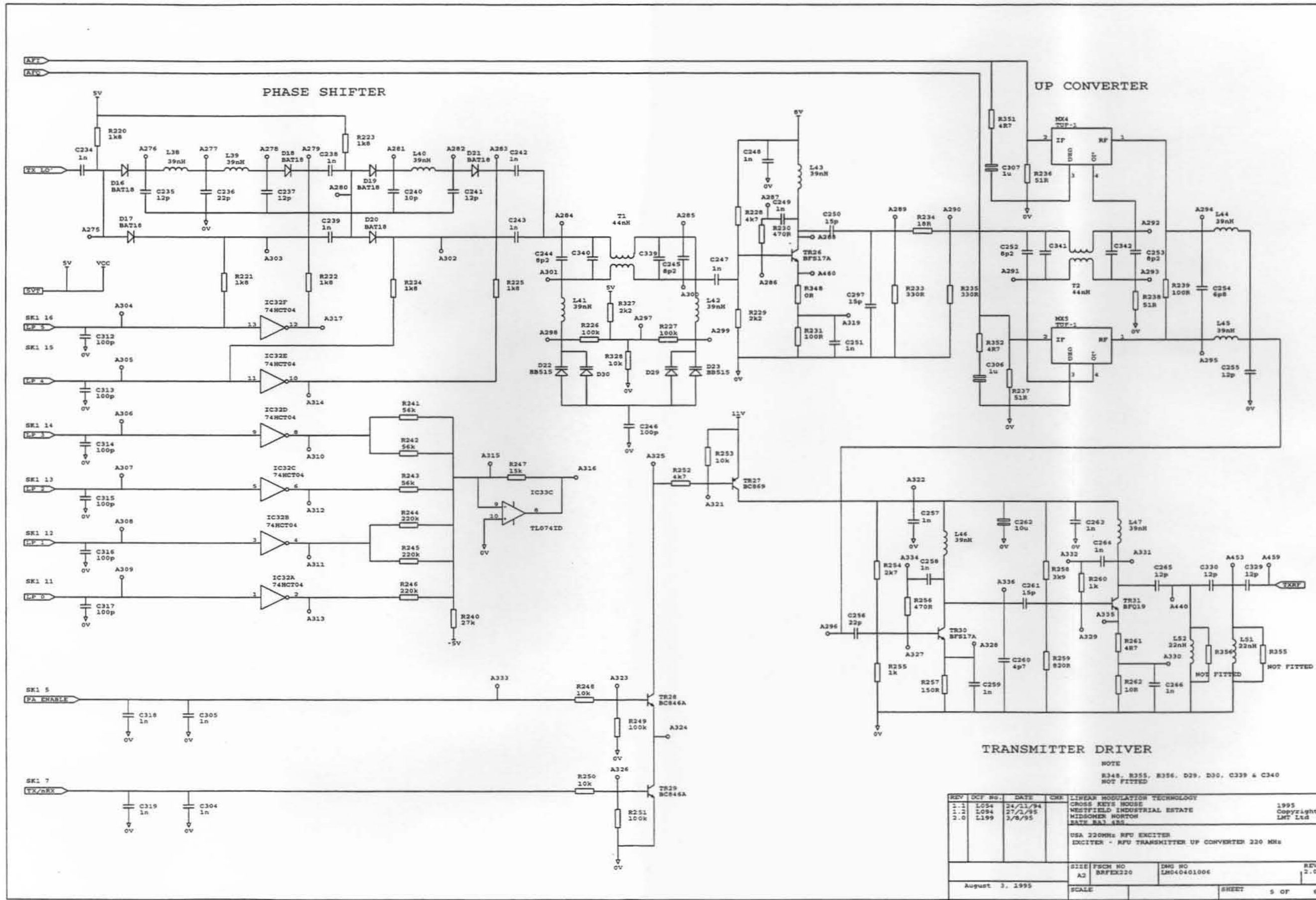

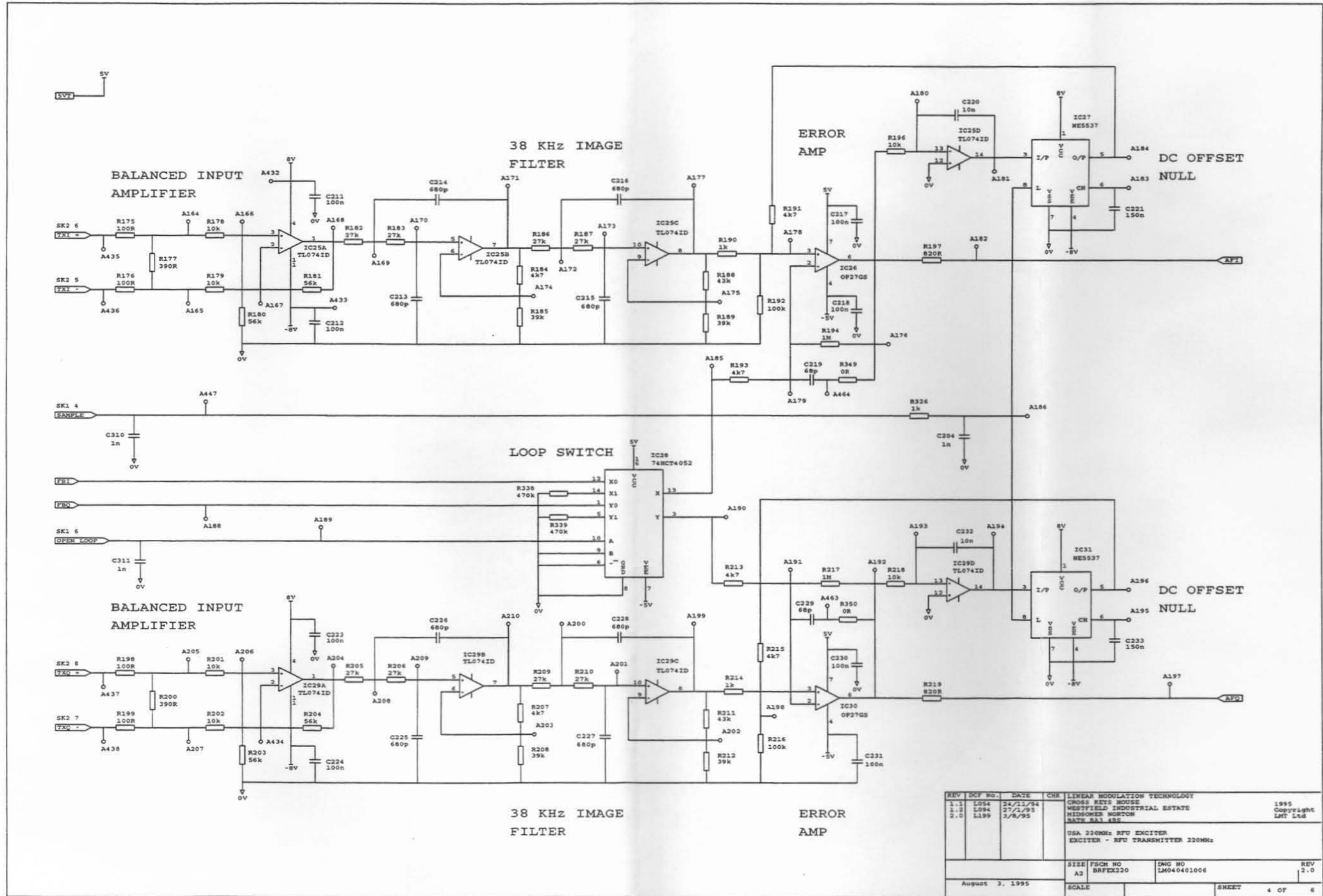

REV	DEF No.	DATE	CHK	LINEAR MODULATION TECHNOLOGY CROSS KEYS MOUSE WESTFIELD INDUSTRIAL ESTATE MIDDORXEN BOSTON MATS DA3 4RE	1995 Copyright LMT Ltd
1.1	L054	24/11/94			
1.2	L094	27/1/95			
2.0	L199	3/8/95			
				USA 230MHz RFU EXCITER EXCITER - RFU TRANSMITTER 230MHz	
		August 3, 1995	SCALE	SIZE A2	REV 2.0
				DWG NO LM040401006	SHEET 4 OF 6

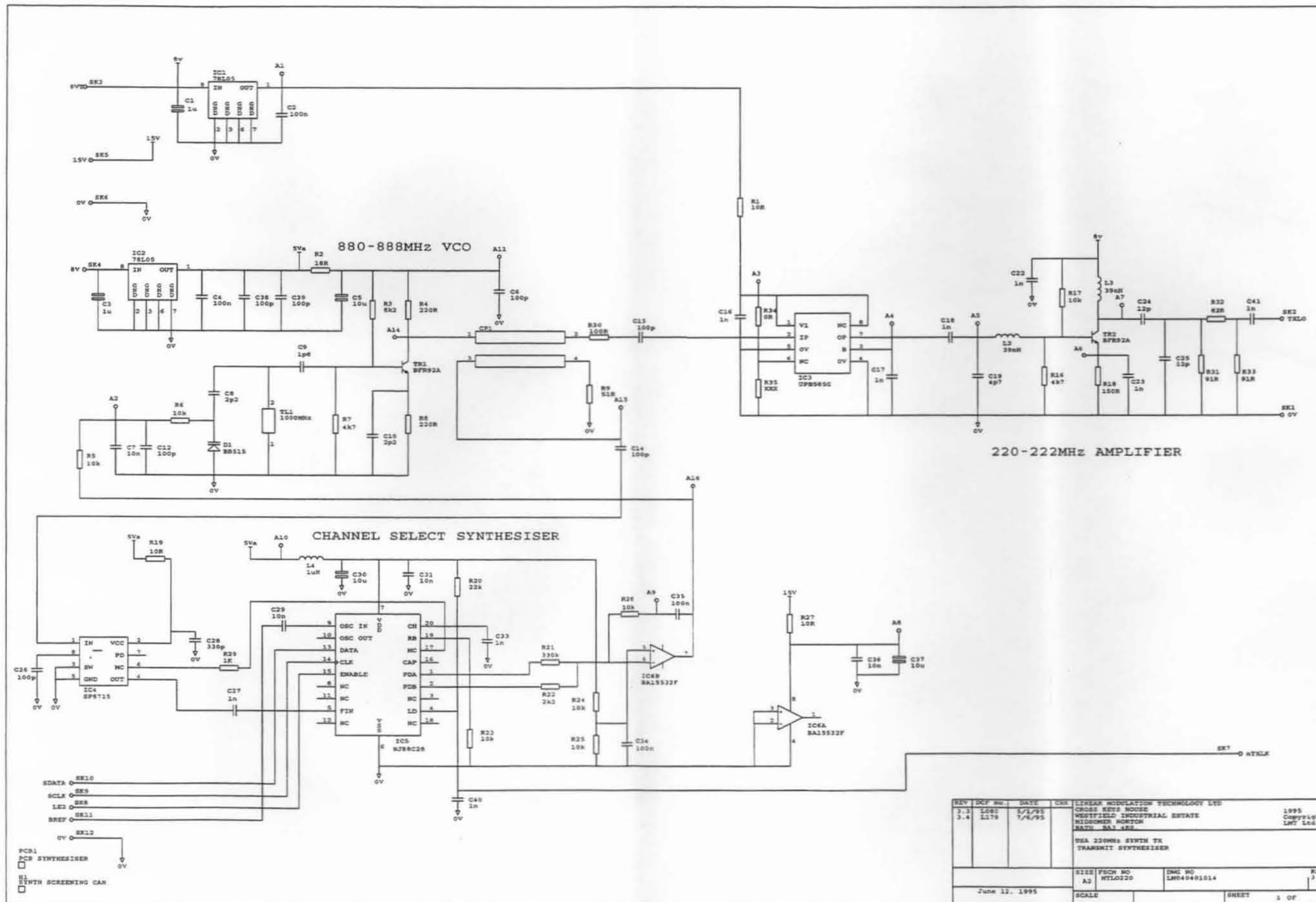

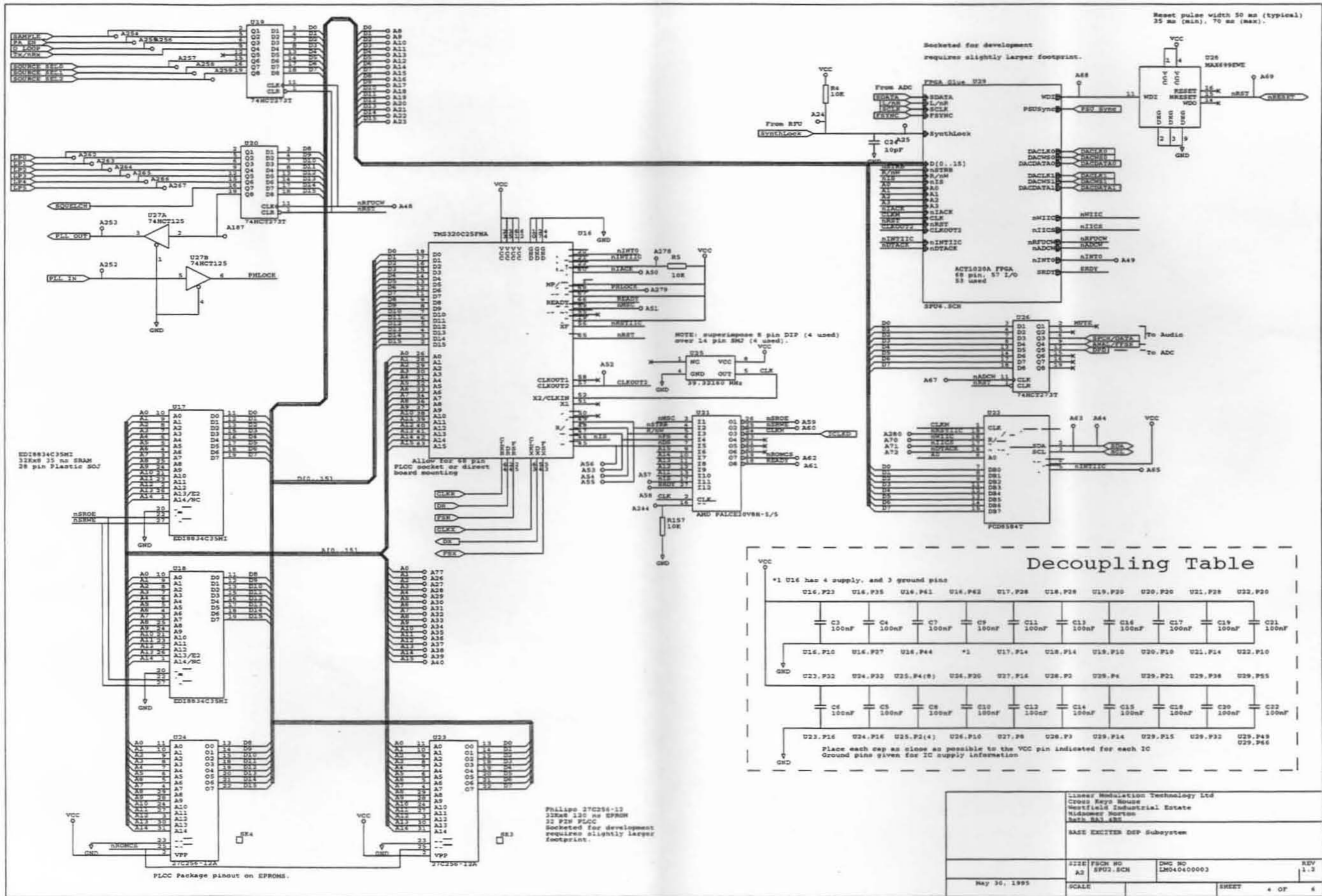



AUDIO

Spare OP-Amps

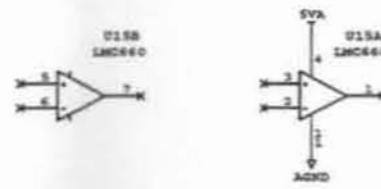

Reference Generation

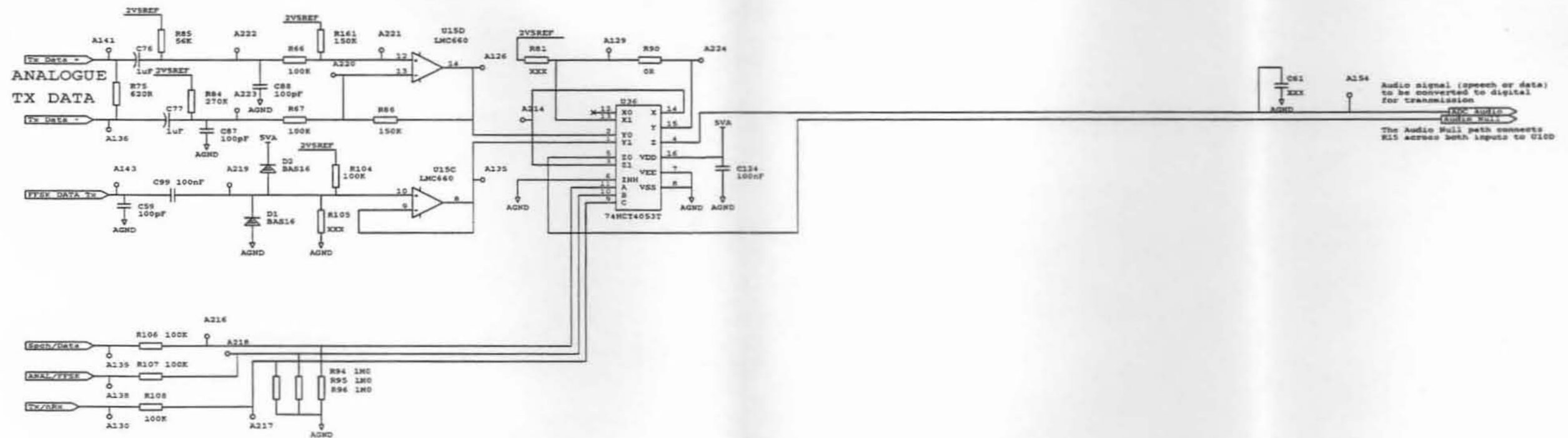
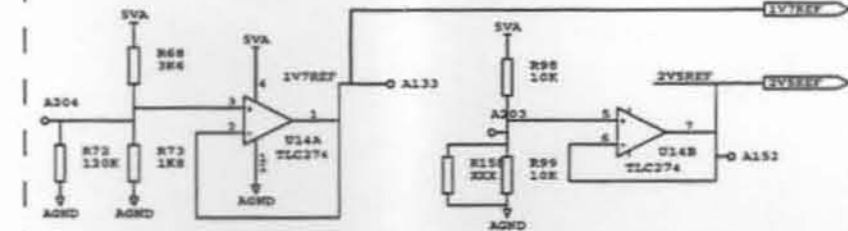

Linear Modulation Technology Ltd Cresc: Keys House Westfield Industrial Estate Midsomer Norton Bath BA1 1SD			
BASE EXCITER SPU AUDIO			
DATE	FIGURE NO	DWG NO	REV
May 30, 1995	A3 SPU3.SCH	LM04040003	1.2
SCALE		SHEET	6 OF 6

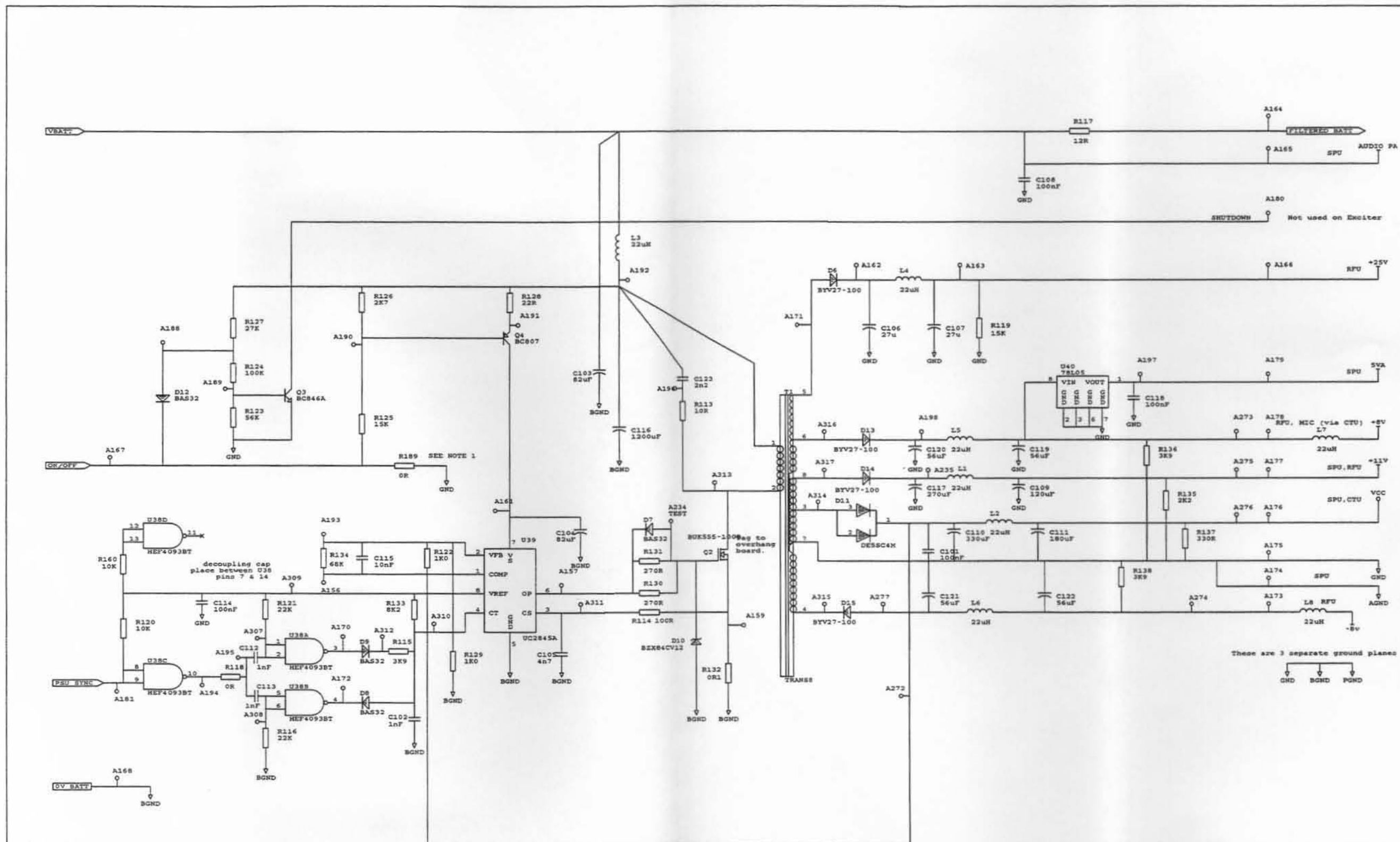

NOTE 1
This resistor overrides the ON/OFF line on base SPU's

Linear Modulation Technology Ltd Cross Keys House Westfield Industrial Estate Widomer Norton Bath BA1 4NS			
BASE EXCITER PSU			
DATE	DSCH NO	DWG NO	REV
June 5, 1995	A3 SPU4.SCH	LM04040003	1.2
SCALE		SHEET	3 OF 4



SPU/RFU Analogue Interface

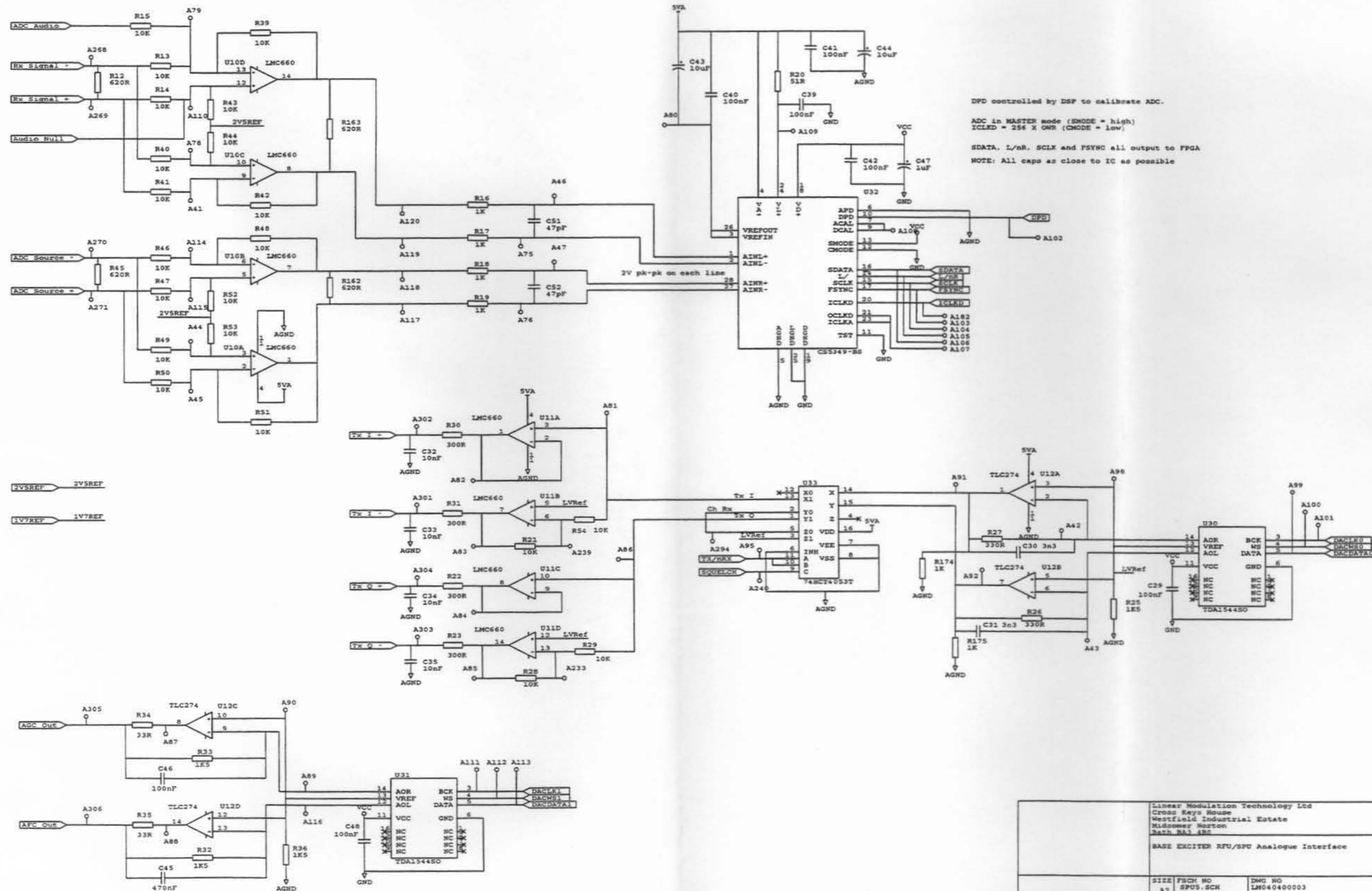

Linear Modulation Technology Ltd Cross Keys House Westfield Industrial Estate Midsummer Norton Bath BA1 1BE			
BASE EXCITER RFU/SPU Analogue Interface			
SIZE	FSCH NO	DWG NO	REV
A2	SPUS.SCH	LM0400003	1.2
May 30, 1995		SCALE	SHEET 2 OF 6

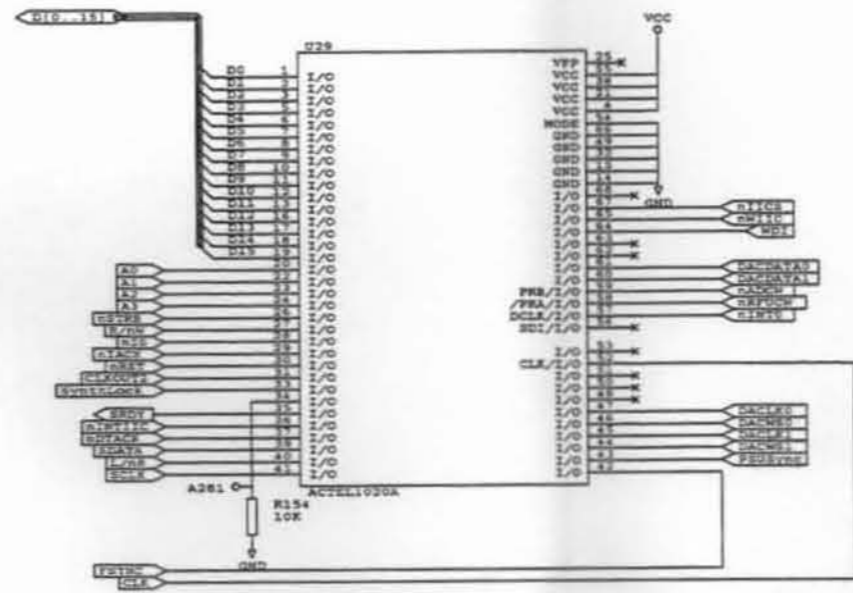

4 UPDATE.
Pins 51, 56, 62 and 68

Linear Modulation Technology Ltd Cross Keys House Westfield Industrial Estate Midsummer Barton Bath BA3 1SE			
EXCITER SPU FPGA			
SIZE A2	FSCH NO SPU4.SCH	DWG NO LM040400003	REV 1.2
May 10, 1995	SCALE	SHEET	1 OF 6



Module Parts List

USA 220 Channel Exciter

Document No: LM030301004

Issue 1.1

Reference	Description	Stock Number
1	EXCITER HOUSING	L004BSE1203A2
1	EXCITER FRONT LMT	L004BSE1204B0
2	SIDE PANEL	L004BSH1004A0
1	CONNECTOR BACK BOX	L004BSH1006A2
1	T0220 SIL PAD	L020T220IPDA0
1	SERIAL N/D LABEL	L026SNLABELB0
14	M2.5X6 P/HEAD TORX BZCP	L02925P6MMTA0
1	M3 X 10MM PAN HEAD TORX	L0293P10MMTA0
1	INSULATING TOP HAT T0220	L029INSTPH1A0
34	M3X6 CSK TORX BZCP	L029M3C6MMTA0
12	M3 CRINKLE WASHER	L029M3CWASHA0
2	M3 NUT BZCP	L029M3NUTXXA0
14	M3X6 PAN HEAD TORX BZCP	L029M3P6MMTA0
8	M3-UNC4 LOCKING SCREWS	L029M3UNCLSA0
2	M3 PLAIN WASHER BZCP	L029M3WASHPA0
2	M3 SHAKEPROOF WASHER	L029M3WASHSA0
2	SLEEVE 3 x 20 RUBBER	L0323X20SLVA0
1	CONN TX LOOM	L033EXLE1IXB0
1	TX OUT LOOM	L033EXLE2IXB0
1	POWER LOOM EXCITER	L033EXLE3IXA1
1	PA DRIVE LOOM	L033EXLE4IXA0
1	10MHz REF LOOM	L033EXLE5IXA0
1	PA CONNS LOOM	L033EXLE6IXA1
1	RF FEEDBACK LOOM	L033EXLE7IXA0
1	RED LED 260 RING	L033EXLE8IXA1
1	INT POWER LOOM	L033EXLE9IXA0
1	48.3mm HANDLE M3X8 FIX	L035HANDLESAA0
1	CONTACT FINGERS LARGE	L044FINGERLAA0
1	1000PF FILTER CON	L066FC1000PAA0



22. 200W Power Supply Unit

Contents

General Assemblies	22-3
Chassis.....	22-3
Module Parts List	22-7
Looms	22-8
IEC-SW DPDT Loom.....L033PSLPS2IA1.....	22-8
Internal Earth Loom.....L033PSLPS5IA2.....	22-9
SW DPDT-PWR Supply Loom.....L033PSLPS3IA1.....	22-10
Red LED 220 Fork.....L033PSLPS4IB1.....	22-11
3W/AXR Power Supply Loom.....L033PSLPS1IA0.....	22-12

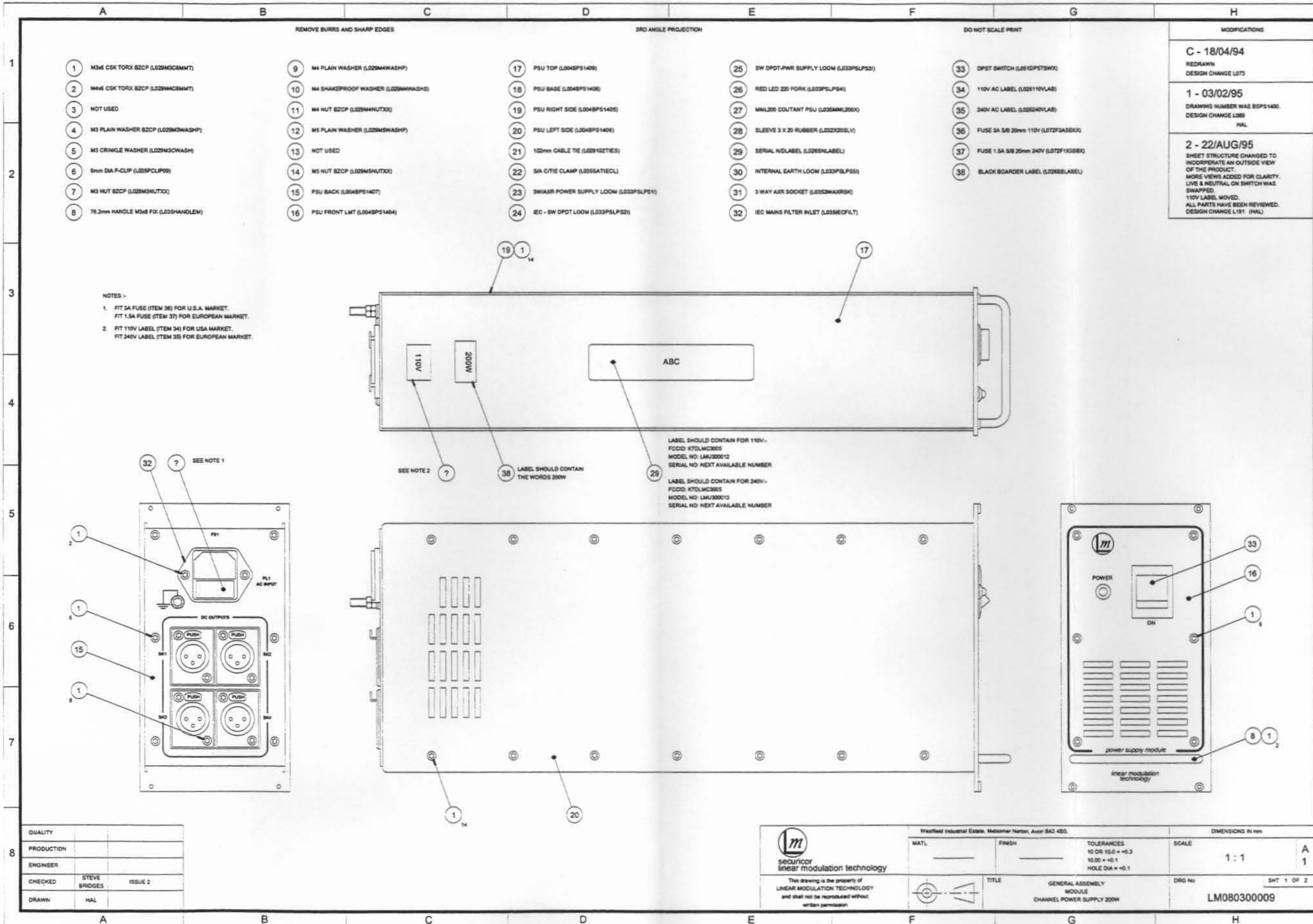

QUALITY		
PRODUCTION		
ENGINEER		
CHECKED	STEVE BRIDGES	ISSUE 2
DRAWN	HAL	

Westfield Industrial Estate, Midsummer Norton, Avon BA2 4BS

secuicor linear modulation technology

TOLERANCES
 10 OR 15.0 ± 0.3
 10.00 ± 0.1
 HOLE DIA ± 0.1

SCALE: 1:1

TITLE: GENERAL ASSEMBLY MODULE CHANNEL POWER SUPPLY 200W

DRG No: LM080300009

SHT 1 OF 2

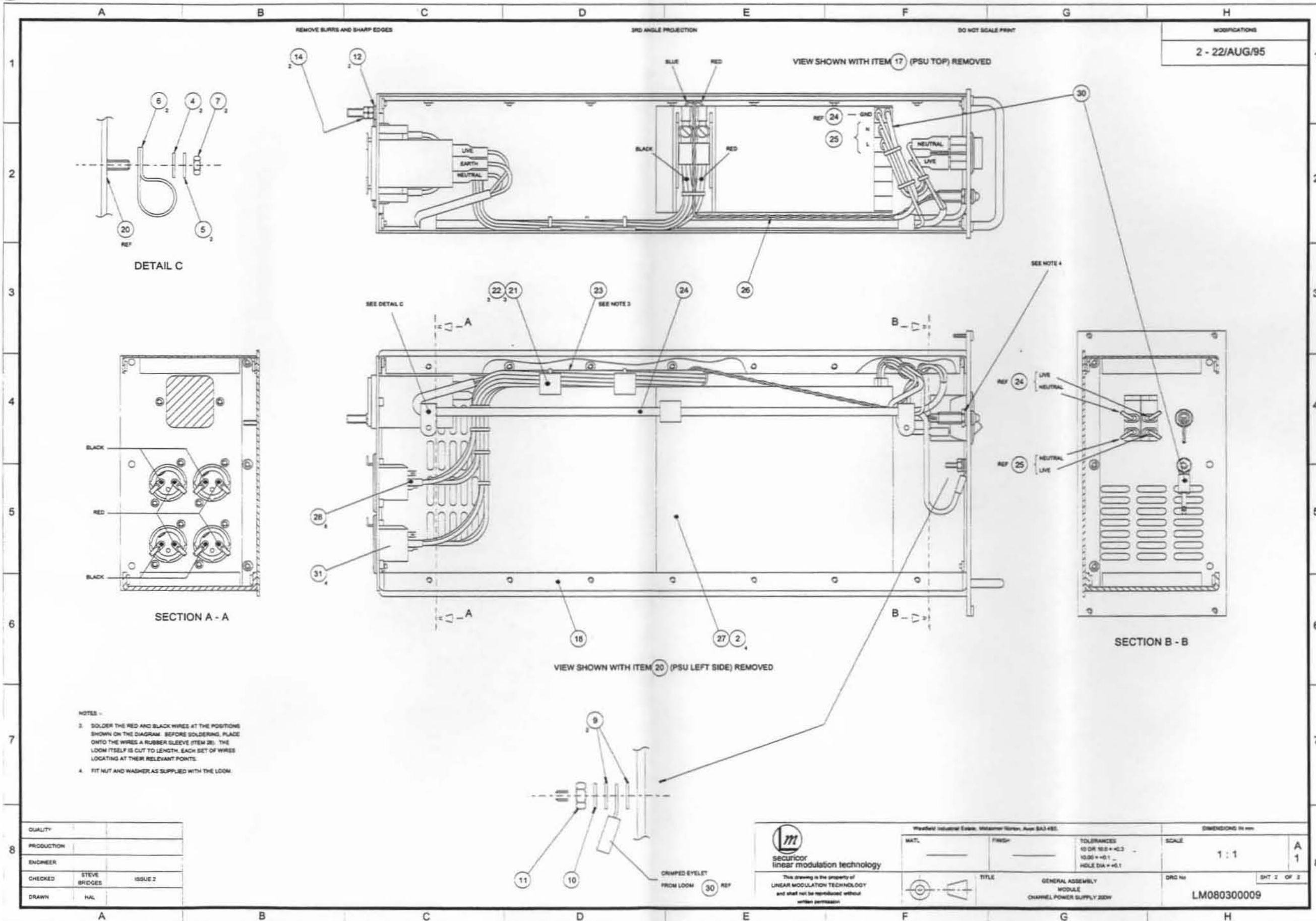



Module Parts List

200W Power Supply Unit

Document No: LM030300009

Issue 1.1

Quantity	Description	Stock Number
1	PSU FRONT LMT	L004BPS1404E0
1	PSU RIGHT SIDE	L004BPS1405A0
1	PSU LEFT SIDE	L004BPS1406A0
1	PSU BACK	L004BPS1407A1
1	PSU BASE	L004BPS1408A1
1	PSU TOP PANEL	L004BPS1409E0
1	110V AC LABEL	L026110VLABA0
1	240V AC LABEL	L026240VLABA0
1	BLACK BORDER LABEL	L026BBLABELA0
1	SERIAL N/D LABEL	L026SNLABELB0
3	102mm CABLE TIE	L029102TIESA0
52	M3X6 CSK TORX BZCP	L029M3C6MMTA0
2	M3 CRINKLE WASHER	L029M3CWASHA0
2	M3 NUT BZCP	L029M3NUTXXA0
2	M3 PLAIN WASHER BZCP	L029M3WASHPA0
4	M4X6 CSK TORX BZCP	L029M4C6MMTA0
1	M4 NUT BZCP	L029M4NUTXXA0
2	M4 PLAIN WASHER	L029M4WASHPA0
1	M4 SHAKEPROOF WASHER	L029M4WASHSA0
2	M5 NUT BZCP	L029M5NUTXXA0
2	M5 PLAIN WASHER	L029M5WASHPA0
8	SLEEVE 3 x 20 RUBBER	L0323X20SLVA0
1	3W/AXR POWER SUPPLY LOOM	L033PSLPS1IA0
1	IEC-SW DPDT LOOM	L033PSLPS2IA1
1	SW DPDT-PWR SUPPLY LOOM	L033PSLPS3IA1
1	RED LED 220 FORK	L033PSLPS4IB1
1	INTERNAL EARTH LOOM	L033PSLPS5IA2
4	3 WAY AXR SOCKET	L0353WAXRSKA0
1	76.2mm HANDLE M3X8 FIX	L035HANDLEMA0
1	IEC MAINS FILTER INLET	L035IECFILTA0
1	MML200 COUTANT PSU	L035MML200XA0
2	9mm DIA P-CLIP	L035PCLIP09A0
3	S/A C/TIE CLAMP	L035SATIECLA0
1	DPST SWITCH	L051DPSTSWXA0
1	FUSE 1.5A S/B 20mm 240V	L072F1X5SBXA0
1	FUSE 3A S/B 20mm 110V	L072F3ASBXXA0

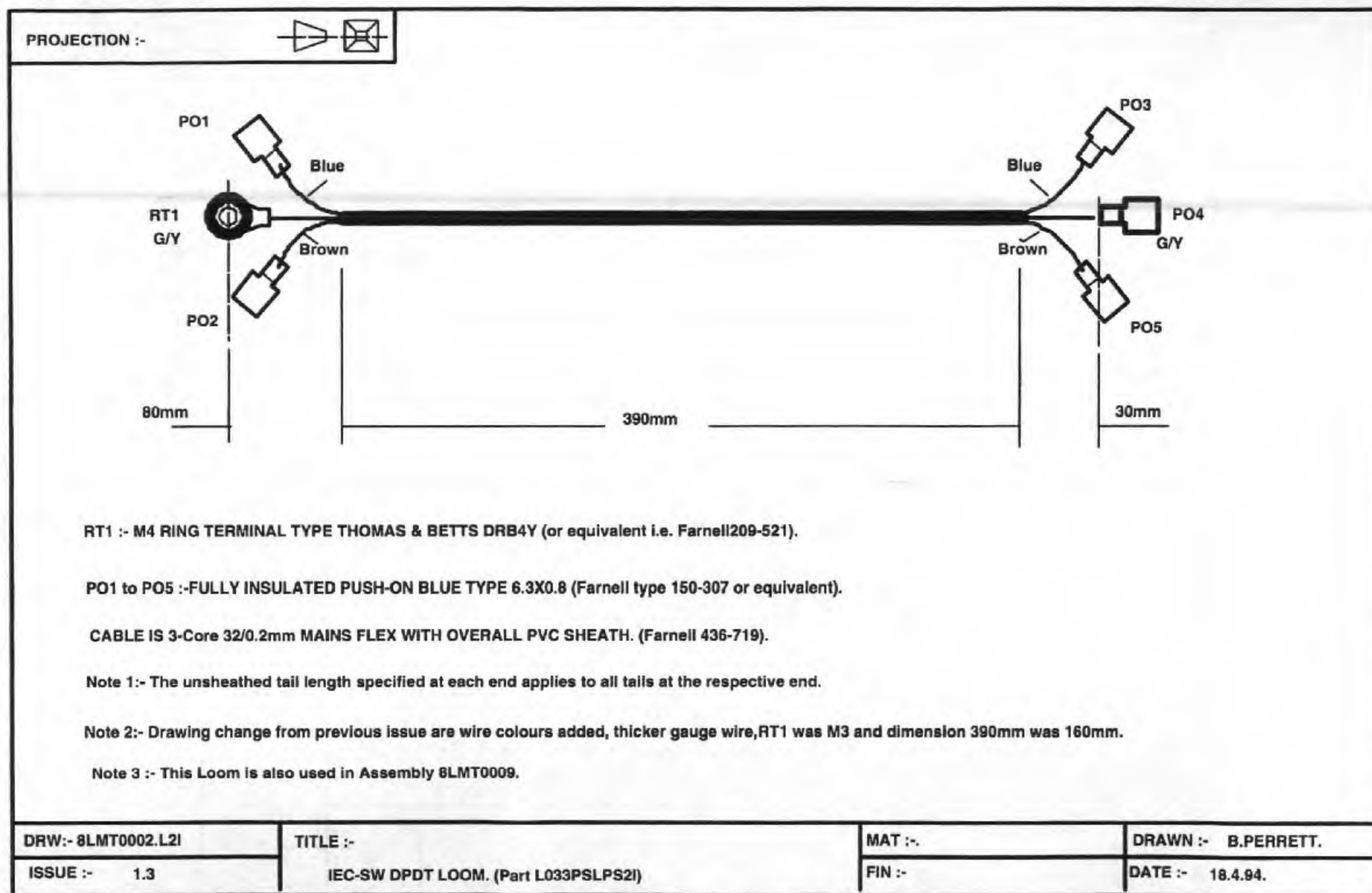



PROJECTION :-											
		<table border="1" style="width: 100%; border-collapse: collapse;"> <tr> <td colspan="2" style="text-align: center;">Modifications.</td> </tr> <tr> <td style="width: 50%;">1.0 :- 18.4.94</td> <td></td> </tr> <tr> <td>1.1 :- 18.6.94</td> <td>Fork M4 was Ring M3.</td> </tr> <tr> <td>A2 :- 5/MAY/95</td> <td>Farnell N' for Ring corrected Fork type red was blue. Tolerance added. DRW was 8LMT0002.L01 DRW N' now Part N' DCF L151. (BRP)</td> </tr> </table>		Modifications.		1.0 :- 18.4.94		1.1 :- 18.6.94	Fork M4 was Ring M3.	A2 :- 5/MAY/95	Farnell N' for Ring corrected Fork type red was blue. Tolerance added. DRW was 8LMT0002.L01 DRW N' now Part N' DCF L151. (BRP)
Modifications.											
1.0 :- 18.4.94											
1.1 :- 18.6.94	Fork M4 was Ring M3.										
A2 :- 5/MAY/95	Farnell N' for Ring corrected Fork type red was blue. Tolerance added. DRW was 8LMT0002.L01 DRW N' now Part N' DCF L151. (BRP)										
<p>FT1 :- M4 FORK TERMINAL RED TYPE DAVICO (or equivalent i.e. Farnell150-285). (Fork Width 6.5mm max)</p> <p>RT2 :- M4 RING TERMINALS TYPE THOMAS AND BETTS DRA4Y (or equivalent i.e. Farnell150-270).</p> <p>WIRE TYPE :- TRI-RATED BS6231 SIZE 32/0.2 GREENYELLOW INSULATION.</p> <p>Note 1:- This Part is also used in Assembly 8LMT0009.</p>											
DRW:- L033PSLPS5I.	TITLE :-	MAT :-	DRAWN :- B.PERRETT.								
ISSUE :- A2	INTERNAL EARTH LOOM.	TOL :- '10mm.	DATE :- 18.4.94.								



PROJECTION :-

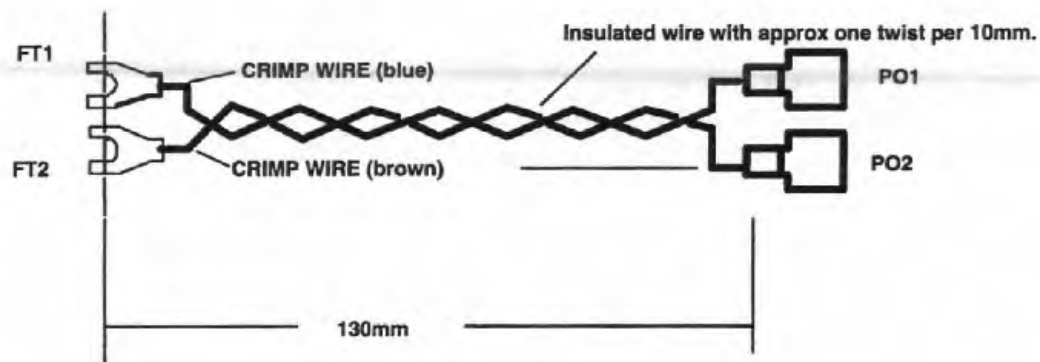
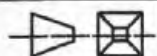

FT1/FT2 :- M4 FORK TERMINAL TYPE DAVICO (or equivalent i.e. Farnell 150-290).

PO1/PO2 :-FULLY INSULATED FEMALE SPADE RED TYPE 6.3X0.8 (Farnell type 150-305 (or equivalent)).

BLUE AND BROWN WIRE TYPES ARE TRI-RATED 16/0.2 TO BS6231.(i.e. Farnell 150-124/150-123).

Note 1:- Drawing issue change fork terminals were ring terminal. (Fork Width to be 6.5mm max).

Note 2 :- This Loom is also used in Assembly 8LMT0009.

DRW:- 8LMT0002.L3I

TITLE :-

MAT :-

DRAWN :- B.PERRETT.

ISSUE :- 1.2

SW DPDT-PWR SUPPLY LOOM. (Part L033PSLPS3)

FIN :-

DATE :- 18.4.94.



PROJECTION :-

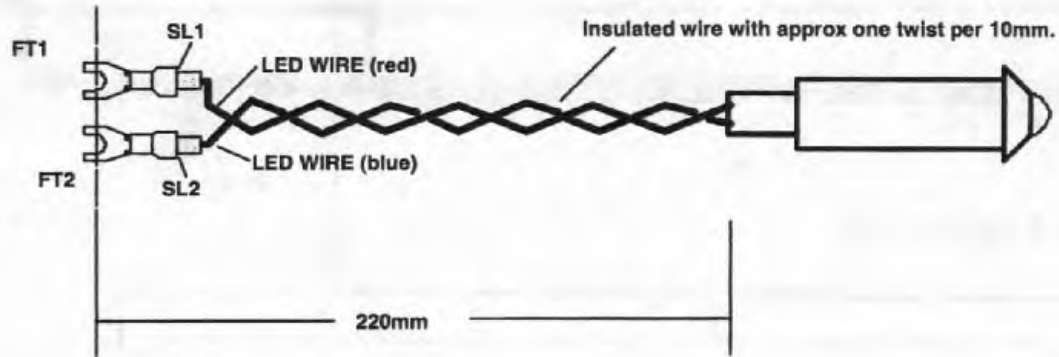
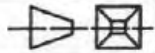

Modifications.

1.0 :- 18.4.94

1.1 :- 18.8.94

Forks were Rings

B1 :- 5/MAY/95

Sleeves added.
Tolerance added.
DRW was SLMT0002.LAI
DRW N' now Part N'

DCF L151. (BRP)

FT1/FT2 :- M4 FORK TERMINALS RED TYPE DRA4FY (or equivalent).

SL1/SL2 :- HELLERMAN H15 SLEEVES (or equivalent).(Front portion of sleeves to be captive in crimped barrel of terminal).

RED PANEL MOUNTING LED :- TYPE HERO SMRD 080-82.(To be supplied with Spring Washer and Locking Nut).

NOTE 1:- Fork Width to be 6.5mm max to pass through locking nut. (Sleeves are too provide extra support to 7/0.2 wire).

NOTE 2 :- LED is supplied with red and blue wires attached. Wires must be cut to specified length and crimped to FT1/FT2.

DRW:- L033PSLPS4I.

TITLE :-

MAT :-

DRAWN :- B.PERRETT.

ISSUE :- B1

RED LED 220 FORK.

TOL :- 10mm.

DATE :- 18.4.94.



PROJECTION :-

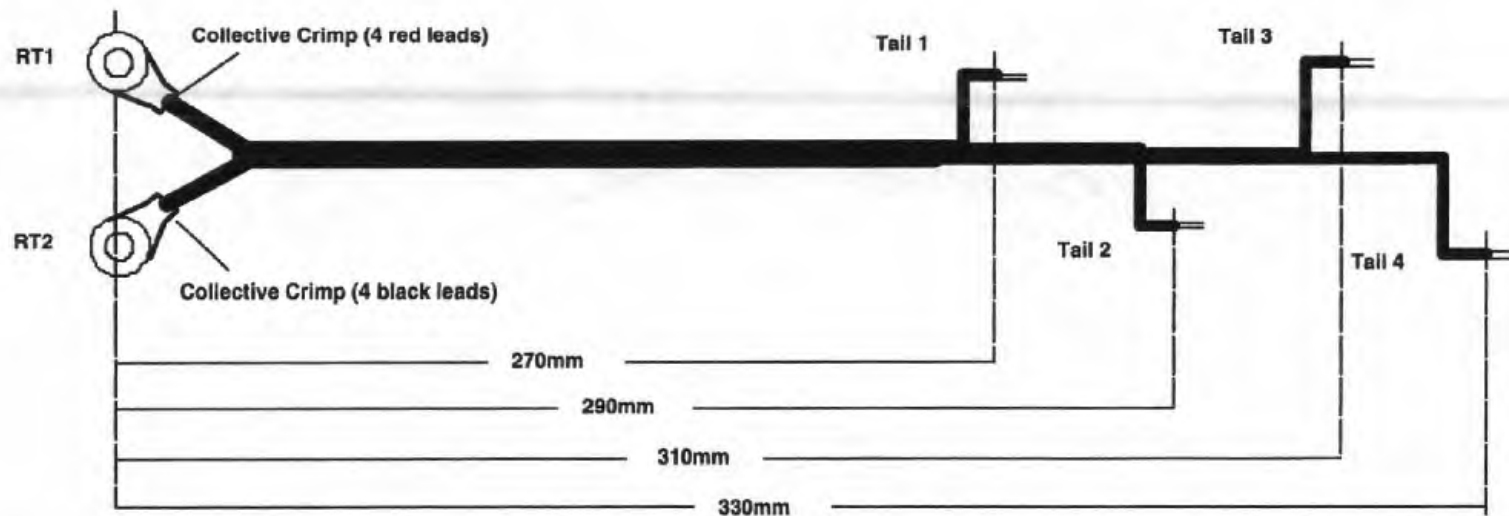
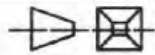

RT1/RT2 :- M6 RING TERMINALS TYPE THOMAS & BETTS DRC6Y (or equivalent i.e. Farnell 209-582).

EACH TAIL TO COMPRISE ONE RED AND ONE BLACK LEAD WITH 5mm STRIPPED AND TINNED ON EACH LEAD.

THE FOUR RED AND FOUR BLACK WIRES ARE INSULATED TRI-RATED BS6231 SIZE 32/0.2.(i.e. Farnell 150-124/150-122).

NOTE :- Dimensions shown have a tolerance of ± 5 mm and are between ring terminal centres and tinning start.

All wires to lie on a single axis even though drawn profiled for clarity.

DRW:- 8LMT0002.L11

TITLE :-

MAT :-

DRAWN :- B.PERRETT.

ISSUE :- 1.0

3W/AXR POWER SUPPLY LOOM. (Part L033PSLPS11)

FIN :-

DATE :- 18.4.94.



23. 400W Power Supply Unit

Contents

General Assemblies	23-3
Chassis.....	23-3
Module Parts List	23-7
Looms	23-8
IEC-SW DPDT Loom.....L033PSLPS2IA1.....	23-8
SW DPDT-PWR Supply Loom.....L033PSLPS3IA1.....	23-9
Internal Earth Loom.....L033PSLPS5IA2.....	23-10
3W/AXR 400W PSU Loom.....L033PSLPS6IB1.....	23-11
Red LED 320 Fork.....L033PSLPS7IB1.....	23-12
400W P/S Ground Strap.....L033PSLPS8IA0.....	23-13

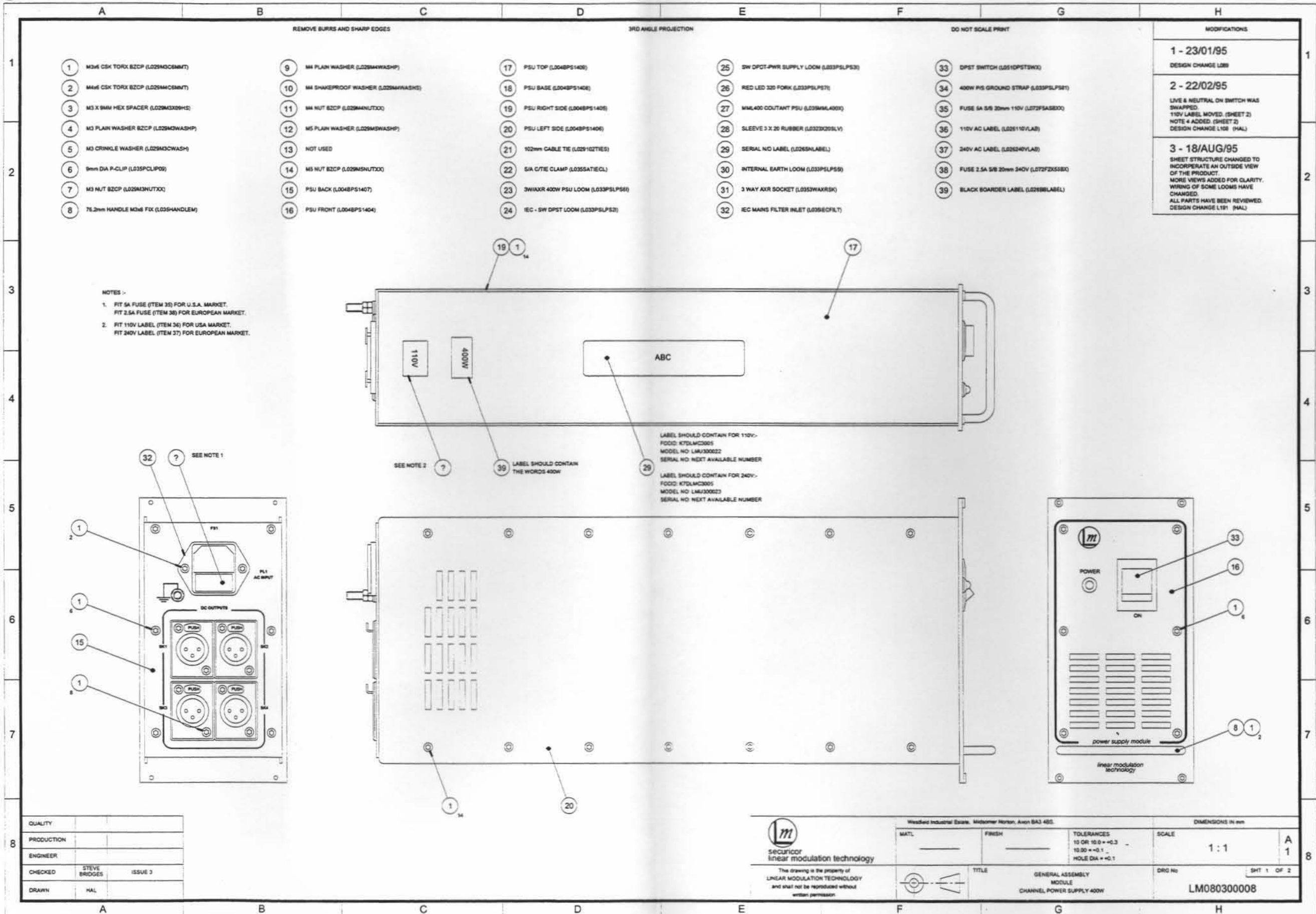

- 1 M3x6 CSK TORX BZCP (L029M3CSMMT)
- 2 M4x6 CSK TORX BZCP (L029M4CSMMT)
- 3 M3 X 9MM HEX SPACER (L029M3X9H5)
- 4 M3 PLAIN WASHER BZCP (L029M3WASHP)
- 5 M3 CRINKLE WASHER (L029M3CWASH)
- 6 9mm DIA P-CLIP (L035PCLIP09)
- 7 M3 NUT BZCP (L029M3NUTX)
- 8 75.2mm HANDLE M3x6 FX (L03SHANDLEM)

- REMOVE BURRS AND SHARP EDGES
- 9 M4 PLAIN WASHER (L029M4WASHP)
 - 10 M4 SHAKEPROOF WASHER (L029M4WASHK)
 - 11 M4 NUT BZCP (L029M4NUTX)
 - 12 M5 PLAIN WASHER (L029M5WASHP)
 - 13 NOT USED
 - 14 M5 NUT BZCP (L029M5NUTX)
 - 15 PSU BACK (L004BPS1407)
 - 16 PSU FRONT (L004BPS1404)

- 3RD ANGLE PROJECTION
- 17 PSU TOP (L004BPS1408)
 - 18 PSU BASE (L004BPS1406)
 - 19 PSU RIGHT SIDE (L004BPS1405)
 - 20 PSU LEFT SIDE (L004BPS1404)
 - 21 102mm CABLE TIE (L029102TIE)
 - 22 SIA C/TIE CLAMP (L035SATIECL)
 - 23 3WAYXR 400W PSU LOOM (L033PSP56)
 - 24 IEC - SW DPST LOOM (L033PSP52)

- 25 SW DPST-PWR SUPPLY LOOM (L033PSP53)
- 26 RED LED 320 FORK (L033PSP57)
- 27 M4L400 COULTANT PSU (L039M4L400)
- 28 SLEEVE 3 X 20 RUBBER (L032930SLV)
- 29 SERIAL NO LABEL (L026SHLABL)
- 30 INTERNAL EARTH LOOM (L033PSP59)
- 31 3 WAY AXR SOCKET (L033WAXR3K)
- 32 IEC MAINS FILTER INLET (L039ECFILT)

- DO NOT SCALE PRINT
- 33 DPST SWITCH (L051DPST3W)
 - 34 400W PIS GROUND STRAP (L033PSP58)
 - 35 FUSE SA S/B 20mm 110V (L072FSA5E00)
 - 36 110V AC LABEL (L026110VLAB)
 - 37 240V AC LABEL (L026240VLAB)
 - 38 FUSE 2.5A S/B 20mm 240V (L072FZK54B0)
 - 39 BLACK BOARDER LABEL (L026BBLABL)

MODIFICATIONS	
1 - 23/01/95	DESIGN CHANGE L28
2 - 22/02/95	LIVE & NEUTRAL ON SWITCH WAS SWAPPED. 110V LABEL MOVED. (SHEET 2) NOTE 4 ADDED. (SHEET 2) DESIGN CHANGE L109 (HAL)
3 - 18/AUG/95	SHEET STRUCTURE CHANGED TO INCORPORATE AN OUTSIDE VIEW OF THE PRODUCT. MORE VIEWS ADDED FOR CLARITY. WIRING OF SOME LOOMS HAVE CHANGED. ALL PARTS HAVE BEEN REVIEWED. DESIGN CHANGE L181 (HAL)

NOTES :-
 1. FIT SA FUSE (ITEM 35) FOR U.S.A. MARKET.
 FIT 2.5A FUSE (ITEM 38) FOR EUROPEAN MARKET.
 2. FIT 110V LABEL (ITEM 36) FOR USA MARKET.
 FIT 240V LABEL (ITEM 37) FOR EUROPEAN MARKET.

LABEL SHOULD CONTAIN FOR 110V:-
 FQID: K7DLMC3005
 MODEL NO: LAMJ300022
 SERIAL NO: NEXT AVAILABLE NUMBER
 LABEL SHOULD CONTAIN FOR 240V:-
 FQID: K7DLMC3005
 MODEL NO: LAMJ300023
 SERIAL NO: NEXT AVAILABLE NUMBER

QUALITY		
PRODUCTION		
ENGINEER		
CHECKED	STEVE BRIDGES	ISSUE 3
DRAWN	HAL	

 securitor linear modulation technology <small>The drawing is the property of LINEAR MODULATION TECHNOLOGY and shall not be reproduced without written permission</small>	Westfield Industrial Estate, Midsummer Norton, Aston BA3 4BS.	DIMENSIONS IN mm	
	MATL	FINISH	SCALE 1:1
TOLERANCES 10 OR 10.0 +0.3 10.00 +0.1 HOLE DIA +0.1	TITLE GENERAL ASSEMBLY MODULE CHANNEL POWER SUPPLY 400W	DRG No LM080300008	SHT 1 OF 2

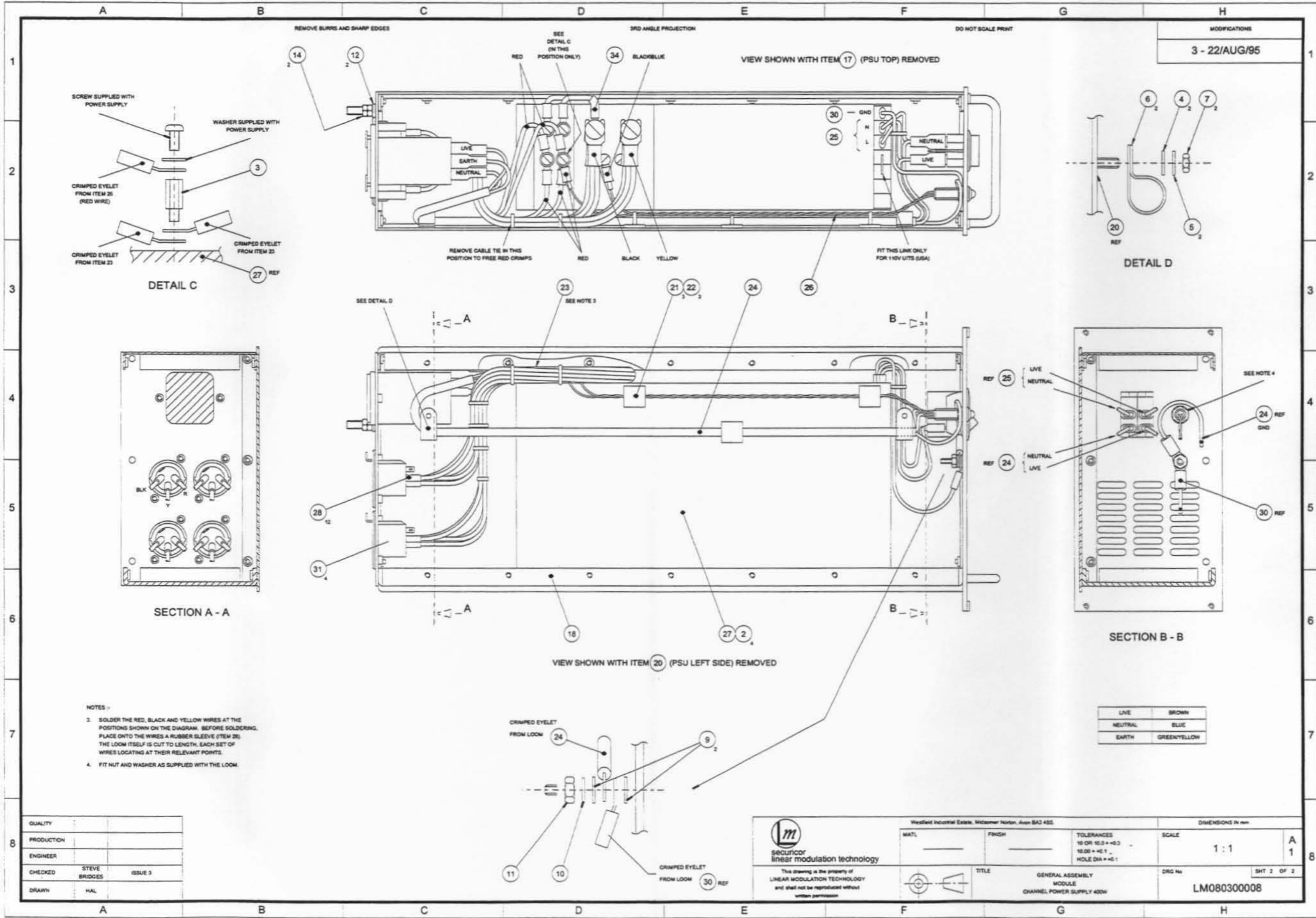



Module Parts List

400W Power Supply Unit

Document No: LM030300008

Issue 1.1

Quantity	Description	Stock Number
1	PSU FRONT LMT	L004BPS1404B0
1	PSU RIGHT SIDE	L004BPS1405A0
1	PSU LEFT SIDE	L004BPS1406A0
1	PSU BACK	L004BPS1407A1
1	PSU BASE	L004BPS1408A1
1	PSU TOP PANEL	L004BPS1409B0
1	110V AC LABEL	L026110VLABA0
1	240V AC LABEL	L026240VLABA0
1	BLACK BORDER LABEL	L026BBLABELA0
1	SERIAL N/D LABEL	L026SNLABELB0
3	102mm CABLE TIE	L029102TIESA0
52	M3X6 CSK TORX BZCP	L029M3C6MMTA0
2	M3 CRINKLE WASHER	L029M3CWASHA0
2	M3 NUT BZCP	L029M3NUTXXA0
2	M3 PLAIN WASHER BZCP	L029M3WASHPA0
1	M3 X 9 mm HEX SPACER	L029M3X09HSA0
4	M4X6 CSK TORX BZCP	L029M4C6MMTA0
1	M4 NUT BZCP	L029M4NUTXXA0
2	M4 PLAIN WASHER	L029M4WASHPA0
1	M4 SHAKEPROOF WASHER	L029M4WASHSA0
2	M5 NUT BZCP	L029M5NUTXXA0
2	M5 PLAIN WASHER	L029M5WASHPA0
12	SLEEVE 3 x 20 RUBBER	L0323X20SLVA0
1	IEC-SW DPDT LOOM	L033PSLPS2IA1
1	SW DPDT-PWR SUPPLY LOOM	L033PSLPS3IA1
1	INTERNAL EARTH LOOM	L033PSLPS5IA2
1	3W/AXR 400W PSU LOOM	L033PSLPS6IB1
1	RED LED 320 FORK	L033PSLPS7IB1
1	400W P/S GROUND STRAP	L033PSLPS8IA0
4	3 WAY AXR SOCKET	L0353WAXRSKA0
1	76.2mm HANDLE M3X8 FIX	L035HANDLEMA0
1	IEC MAINS FILTER INLET	L035IECFILTA0
1	MML400 COUTANT PSU	L035MML400CXAO
2	9mm DIA P-CLIP	L035PCLIP09A0
3	S/A C/TIE CLAMP	L035SATIECLA0
1	DPST SWITCH	L051DPSTSWXA0
1	FUSE 2.5A S/B 20mm 240V	L072F2X5SBXXA0
1	FUSE 5A S/B 20mm 110V	L072F5ASBXXA0

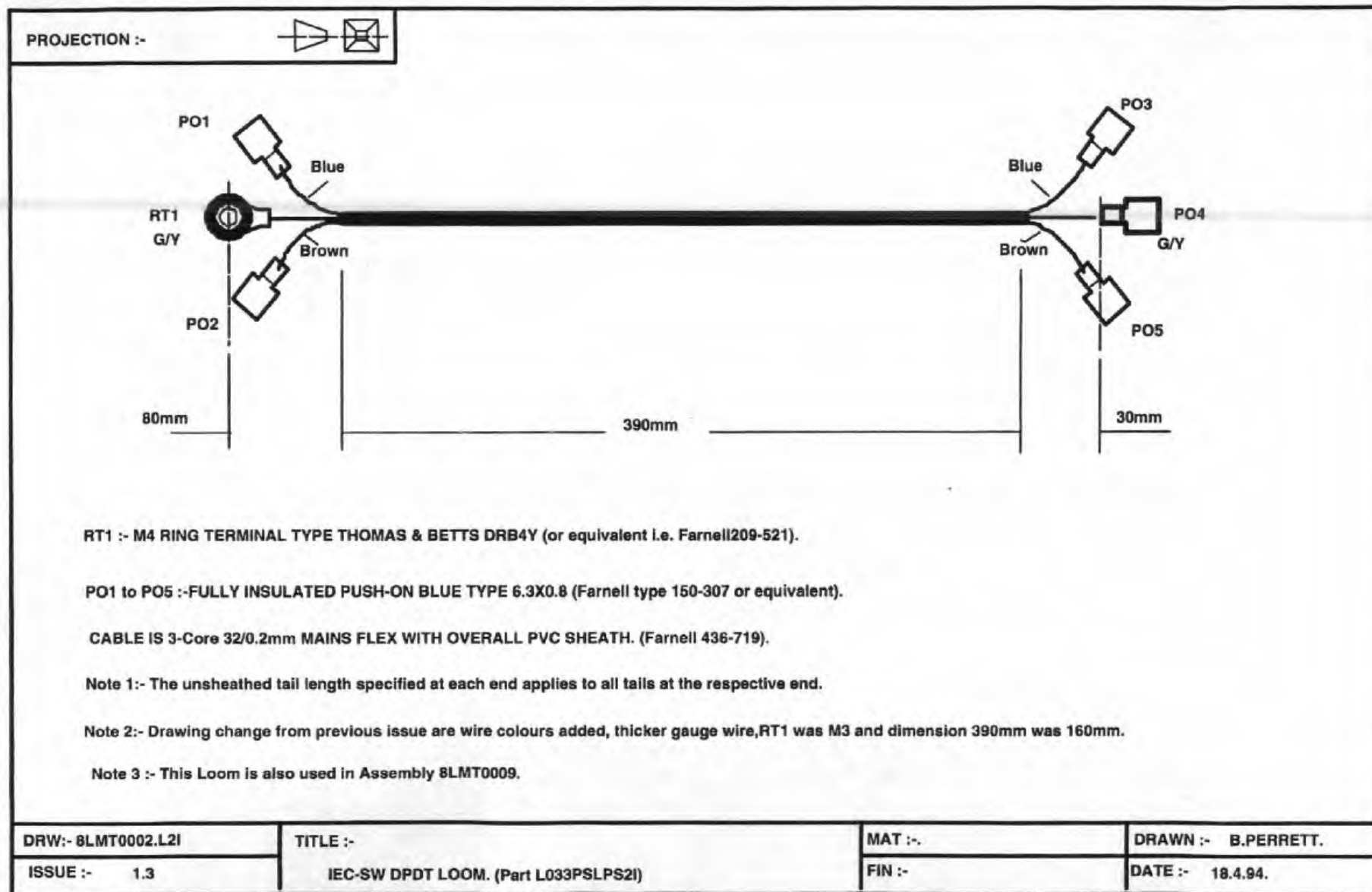



PROJECTION :- 

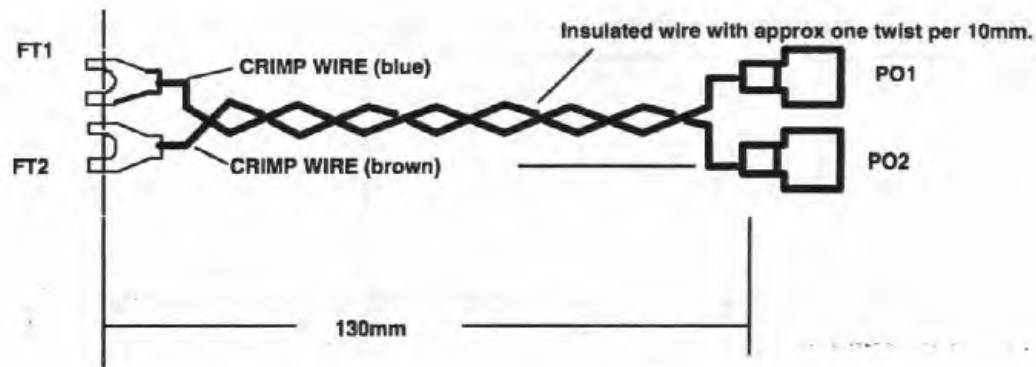

FT1/FT2 :- M4 FORK TERMINAL TYPE DAVICO (or equivalent i.e. Farnell 150-290).

PO1/PO2 :- FULLY INSULATED FEMALE SPADE RED TYPE 6.3X0.8 (Farnell type 150-305 (or equivalent)).

BLUE AND BROWN WIRE TYPES ARE TRI-RATED 16/0.2 TO BS6231.(i.e. Farnell 150-124/150-123).

Note 1:- Drawing issue change fork terminals were ring terminal. (Fork Width to be 6.5mm max).

Note 2 :- This Loom is also used in Assembly 8LMT0009.

DRW:- 8LMT0002.L3I	TITLE :-	MAT :-	DRAWN :- B.PERRETT.
ISSUE :- 1.2	SW DPDT-PWR SUPPLY LOOM. (Part L033PSLPS3I)	FIN :-	DATE :- 18.4.94.

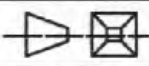
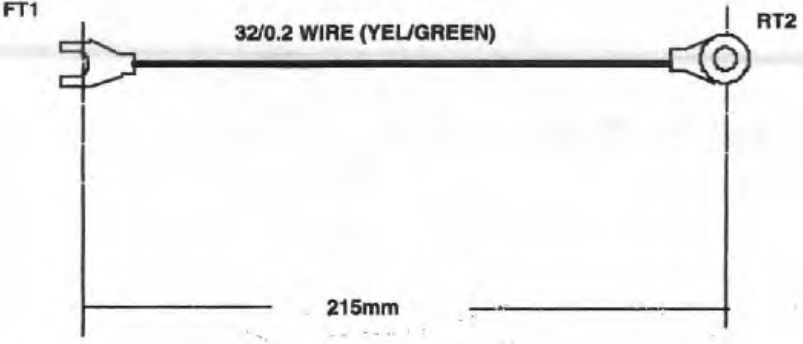

PROJECTION :- 		Modifications.	
		1.0 :- 18.4.94	
		1.1 :- 18.8.94 Fork M4 was Ring M3.	
		A2 :- 5/MAY/95 Farnell N for Ring corrected Fork type red was blue. Tolerance added. DRW was 8LMT0002.L10 DTRW N now Part N DCF L151. (BRP)	
			
<p>FT1 :- M4 FORK TERMINAL RED TYPE DAVICO (or equivalent i.e. Farnell150-285). (Fork Width 6.5mm max)</p> <p>RT2 :- M4 RING TERMINALS TYPE THOMAS AND BETTS DRA4Y (or equivalent i.e. Farnell150-270).</p> <p>WIRE TYPE :- TRI-HATED BS6231 SIZE 32/0.2 GREEN/YELLOW INSULATION.</p> <p>Note 1:- This Part is also used in Assembly 8LMT0009.</p>			
DRW:- L033PSLPS51.	TITLE :-	MAT :-	DRAWN :- B.PERRETT.
ISSUE :- A2	INTERNAL EARTH LOOM.	TOL :- '10mm.	DATE :- 18.4.94.

400W POWER SUPPLY UNIT

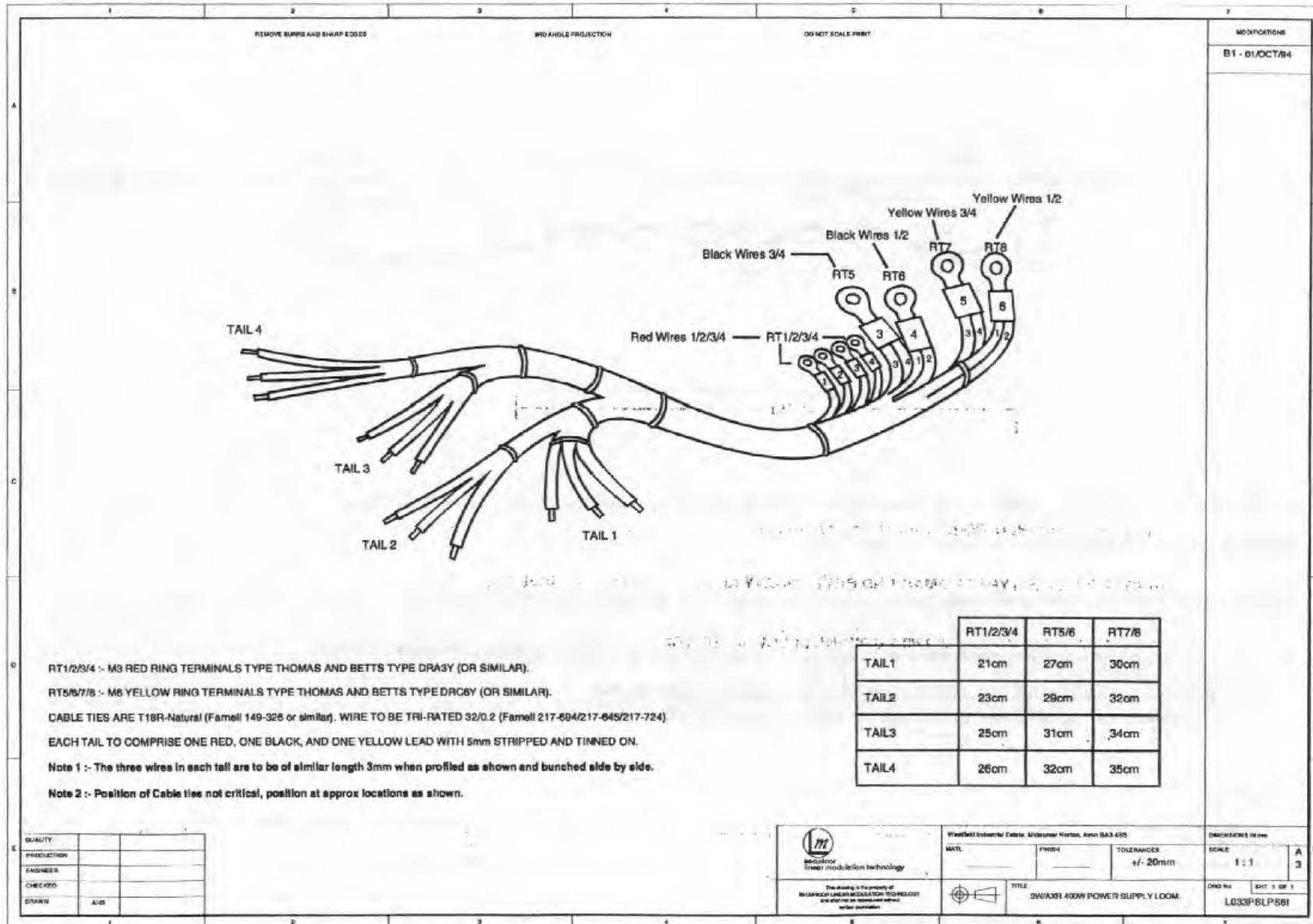

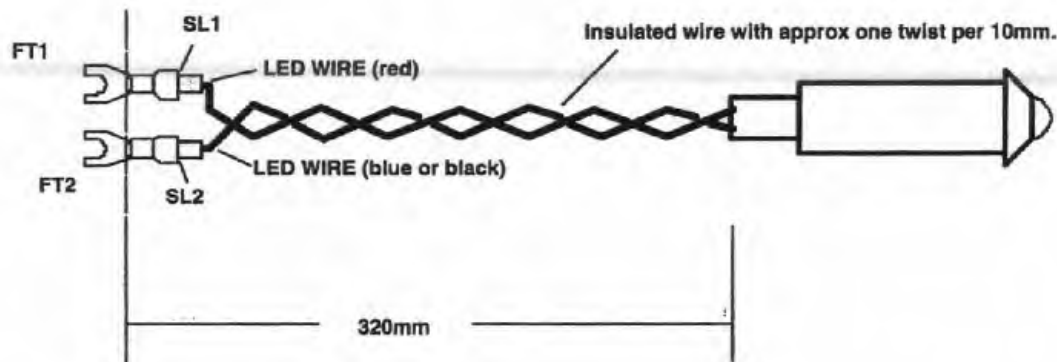
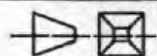

PROJECTION :-

**Modifications.**

1.0 :- 18.4.94

1.1 :- 18.8.94

Forks were Rings

B1 :- 5/MAY/95

Sleeves added.
Tolerance added.
DRW was 8LMT0000.L41
DRW N' now Part N'

DCF L151. (BRP)

SL1/SL2 :- HELLERMAN H15 SLEEVES (or equivalent).(Front portion of sleeves to be captive in crimped barrel of terminal)

FT1/FT2 :- M4 FORK TERMINALS TYPE DRA4FY (or equivalent).

PANEL MOUNTING LED :- TYPE HERO SMRD 080-82. (Red) (To be supplied with Spring Washer and Locking Nut)

NOTE 1 :- LED is supplied with red and blue wires attached.Load sleeves, cut wires to specified length and crimped to FT1/FT2.

NOTE 2 :- This loom can also be used in Assembly 8LMT0002 to replace Part L033PSLPS41.
However Part L033PSLPS41 cannot be used in assembly 8LMT0009.

Drawing Issue changes :-Fork Terminals were Ring Terminals (Fork width to be 6.5mm max).

DRW:- L033PSLPS71

TITLE :-

MAT :-

DRAWN :- B.PERRETT.

ISSUE :- B1

REQ LED 320 FORK.

TOL :- 10mm.

DATE :- 18.4.94.

