



## ID-1

### Morse Code Identifier

Manual Revision: 2007-08-23

Covers Software Revisions:

ID-1: 2.4 & Higher

#### SPECIFICATIONS

Operating Voltage	5.5-15 VDC
Operating Current	3 mA
Operating Temperature	-30 - +60 C
Audio Output Level	1 V RMS
Audio Output Impedance	10 KW or 22 KW
PTT Output Current	100 mA

#### GENERAL INFORMATION

The ID-1 is a Morse Code station identifier capable of encoding 2 different Morse Code sequences either on a continuous cycle or after PTT.

#### HARDWARE INSTALLATION

Be certain to follow standard anti-static procedures when handling any of Midian's products.

**P1-4 – Black** – Ground – Connect to the nearest ground point.

**P1-2 – Red** - +5.5 – 15 VDC – Connect to switched B+ in the radio.

**P1-3 – Brown** – COR/COS – Connect to point in the squelch or CTCSS circuit that changes logic level when carrier is received. If the point in the radio only make a minute change, it may be necessary to adjust R2 & R3 to cause Q1 to change states.

**P1-1 – Green** – TX Tone Out – Connect to the modulator circuit. Use high impedance point in the radio. In Low-Z mic circuits, it may be necessary to short R31 and increase C10.

**P1-8 – Green/White** – Mic Mute – If desired, connect to mic element bias point or to some other point in the audio amp to crowbar mic audio to ground during ID to prevent voice interference.

**P1-5 – Blue** – Alert Tone/Speaker Audio – Connect to high side of the speaker. This provides Morse ID, Time-Out Timer and Go Ahead tones. When using 20-40 Ohm speakers, the onboard resistor in series with Q3 should be sufficient. When attaching this lead to a 4-8 Ohm speaker, add a 100-Ohm resistor in series with the lead to limit current.

**P1-11 – Gray** – PTT In – Used in After PTT mode, this input, when taken to ground, will activate the Morse ID. Open the radio's PTT line and connect this wire closest to the PTT input side of the radio. In After PTT mode, if Common PTT is being used do not open the PTT line in the radio and tie PTT In and PTT Out together.

**P1-9 – White** – PTT Out – Connect to the output side of the break point mentioned in PTT In above. This keeps the radio keyed while sending Morse. In After PTT mode, if Common PTT is being used do not open the PTT line in the radio and tie PTT In and PTT Out together.

**P1-12 – Orange/White** – Program Input/Message Select Input – For Program In, this lead is connected to the Green lead from the KL-3 programmer. For Message Select Input, this lead is left floating for Station ID 1 and grounded for Station ID 2.

**P1-13 – Violet** – Inhibit Input – When taken to active state programmed in the ID-1 the unit will not transmit the ID until the state of this input returns to the inactive state.

#### HARDWARE ALIGNMENT

For the TX Audio Output in a wide band system, set the modulation pot R30 to 3.3 KHz (66% of 5 KHz) of deviation per EIA specifications. For the TX Audio Output in a narrow band system, set the modulation pot R30 to 1.65 KHz (66% of 2.5 KHz) of deviation per EIA specifications.

#### PRODUCT PROGRAMMING

Programming is accomplished using the KL-3 programmer or from a 12 button row/column type keypad. Midian recommends using the KL-3 for greater ease in programming.

## KL-3 Programming:

Please reference the KL-3 manual for setup instructions of the KL-3 software and hardware. From the product selection screen on the KL-3 software, select the appropriate product name from the list and click OK.

Set the parameters of the ID-1 to fit the application. If any clarifications on a feature are required, move the mouse cursor over the feature name until the question mark appears and right click, a definition of the feature will be shown.

After entering the parameters, save the file by going to File - Save As. Enter the file name in the File Name block and click Save. Saving the file will allow for quick and easy reprogramming of units.

Connect the Orange/White wire to the Green KL-3 lead and the Black wire to a common ground with the KL-3's Black lead. The Yellow clip lead is not used with this product, as the ID-1 is non-readable.

Ground the PTT In (Gray Wire); turn on power, and within 5 seconds click "Program Unit" in the menu bar to send the file to the ID-1.

## Keypad Programming:

To enter programming mode type the following sequence:

**27182818284**

The unit will beep 3 times to confirm entry into programming mode.

## Registers 1 & 2

Press \*1 to program alphanumeric register R1 for station ID. Press \*2 to program alphanumeric register R2 for message or secondary ID. When in the alphanumeric programming mode, pressing a button once selects the first character and generates a single beep. Pressing the button twice selects the second character, emitting two beeps. Pressing the button three times, selects the third character, emitting three beeps. Pressing the button four times selects the number and generates a solid tone. To program the character and advance to the next position in the word, press \* once. To advance to the next word, press \*\*. Pressing # exits the alphanumeric programming mode. To exit the register programming mode, press \*0.

Please Note: Registers R1 and R2 are alphanumeric registers and are programmed differently than registers R3 through R9.

## Registers 3-9

To change the contents of any system register except R1 or R2, key in the required data from the programming sheet then press \* n where n=register 3-9. If fewer digits are entered than the register requires, trailing zeros are assumed. Extra digits are ignored.

To exit the programming mode, press \* 0. The unit will respond with a long beep and resume normal operation.

## PROGRAMMABLE FEATURES

**Station ID 1:** Enter the desired station ID in this register up to 16 characters in length. With the Orange/White wire floating, this is the selected ID.

**Station ID 2:** Enter the desired station ID in this register up to 130 characters in length. With the Orange/White wire grounded, this is the selected ID.

**Tone Frequency (Hertz):** Enter a value from 0001 to 3000. This sets the frequency of the Morse Code ID tones.

**ID Repeat Time (Minutes):** Enter a value from 00 to 99. The ID will be transmitted however often this field is programmed to when set for continuous operation. When set for operation After PTT, Midian recommends setting this time to 00. For continuous operation this value should be 01 or higher. **Note:** The time starts at the end of the previous ID.

**Speed (Words per Minute):** Enter a value from 01-99. FCC rules mandate a speed between 20-25 wpm. This is the rate at which the tones are generated.

**Wait Period After Loss of COR/COS Input Before IDing (Seconds):** Enter a value from 01-99. This is the time the unit will wait to send the selected ID after the unit sees a loss of COR or Inhibit when in Continuous operation. If using After PTT operation this becomes a timer for a loss of PTT rather than COR.

## Output Control:

- **After PTT:** If selected the ID-1 will only transmit the station ID after PTT In is grounded.
- **Continuous:** If selected the ID-1 will transmit the station ID continuously based on the programmed ID Repeat Time. Note: For this function leave the COR Input floating and

program the COR/COS/CTCSS Active Polarity to V+.

**Key-Up Delay (Seconds):** Enter a value from 0.0 to 9.9 seconds. This is the time after the units is keyed until the tones are generated.

**Time Out Time (Seconds):** Enter a value from 0-999. Entering a 0 disables this function. If the unit is keyed for the time programmed the unit will unkey itself.

**PTT Drop Out Time (Seconds):** Enter a value from 0-9. This sets the time after PTT In is lost that the unit will keep the PTT Out held. This feature is only available in After PTT operation.

**COR/COS/CTCSS Active Polarity:** This sets the active Polarity of the COR Input. This should match the active COR state that the radio gives the ID-1 when the channel is busy. Ground equals a ground or float condition and V+ equals +5 V.

**Inhibit Line Active Polarity:** If the inhibit line is used this will keep the unit from sending the ID until the line goes to the inactive state. Ground equals a ground condition and V+ equals +5 V or floating.

#### Common PTT:

- **PTT In and PTT Out are Tied to Separate Points:** If selected the Go-Ahead beep and PTT Drop Out Time are available.
- **PTT In and PTT Out are Tied Together:** Select this feature if Common PTT is being used. With this selected the Go-Ahead beep and PTT Drop Out Time are not available.

#### PTT Loss Go-Ahead Beep:

- **Do Not Transmit:** If selected the ID-1 will not generate a beep when the PTT In is lost.
- **Transmit:** If selected the ID-1 will generate a beep when the PTT In is lost.

## OPERATION

#### Station ID Select:

- If only Station ID 1 is being used leave the orange/white wire unconnected and program Station ID 1 as desired.

- If only Station ID 2 is being used connect the orange/white wire to ground and program Station ID 2 as desired.

- If both Station IDs are being used then the floating state is Station ID 1 and the grounded state is Station ID 2. Program both IDs as desired.

**Continuous Operation:** In continuous mode the ID-1 will send the ID after the ID Repeat Time expires. This time starts at the end of each ID. If the COR Input or the Inhibit Input are active at the time the unit attempts to transmit the unit will hold off transmitting the ID until after the input(s) goes inactive and the Wait Period After Loss of COR time expires.

**After PTT Operation:** In the After PTT mode the ID-1 will send the ID after the PTT Input is grounded and then released. Upon release the unit will hold the PTT Out for the time set in the PTT Drop Out Time and then the unit will wait for the amount of time set in the Wait Period After Loss of COR.

## TECHNICAL NOTES

**ID Repeat Time:** FCC Rules state that the station be identified during each transmission of exchange of transmissions. During periods of continuous operation the station must be identified: once each 15 minutes for commercial, once each 10 minutes for amateur, or once each 30 minutes in public safety and special emergency radio services.

**Speed:** FCC rules state that the transmission rate shall be between 20 and 25 WPM.

## MIDIAN CONTACT INFORMATION

**Midian Electronics Inc.**  
2302 East 22<sup>nd</sup> Street  
Tucson, Arizona 85713 USA

**Orders:** 1-800-MIDIANS  
**Phone:** 520-884-7981  
**Fax:** 520-884-0422  
**E-mail:** [sales@midians.com](mailto:sales@midians.com)  
**Web:** <http://www.midians.com/>



### Register 8: Miscellaneous

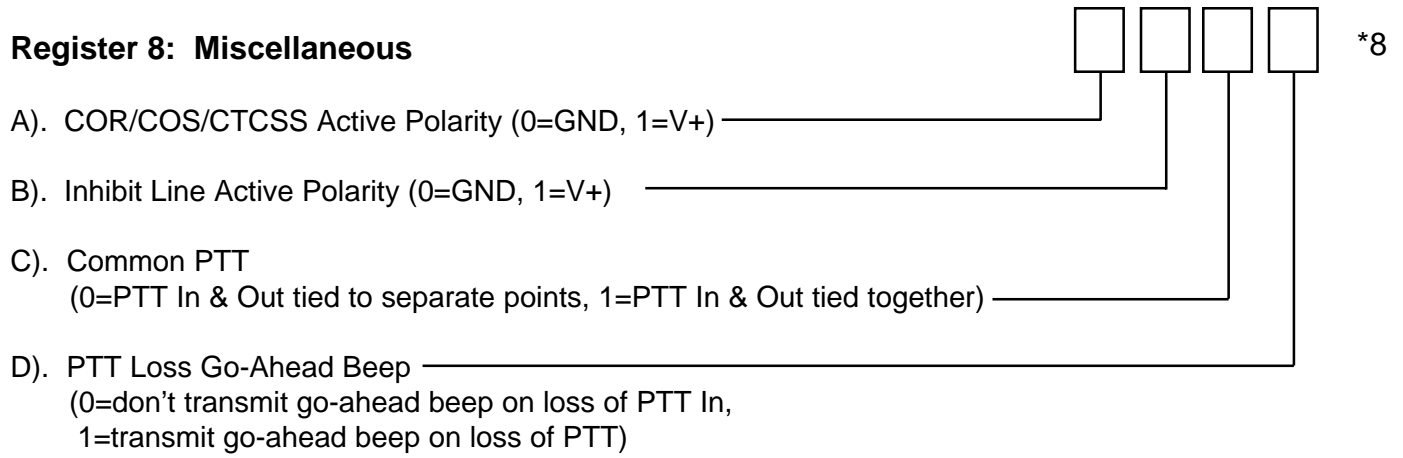

### Register 9: PTT Timing

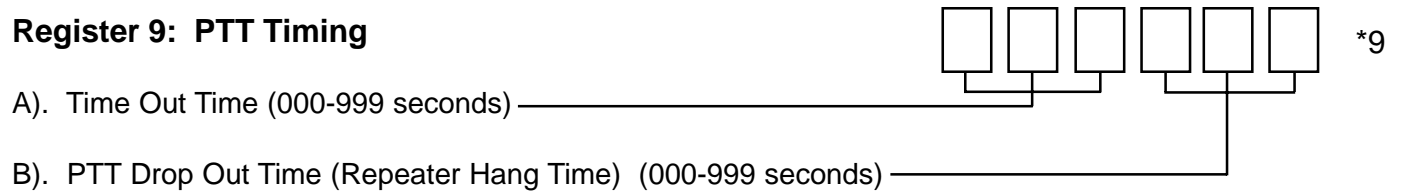

*- This page intentionally left blank -*

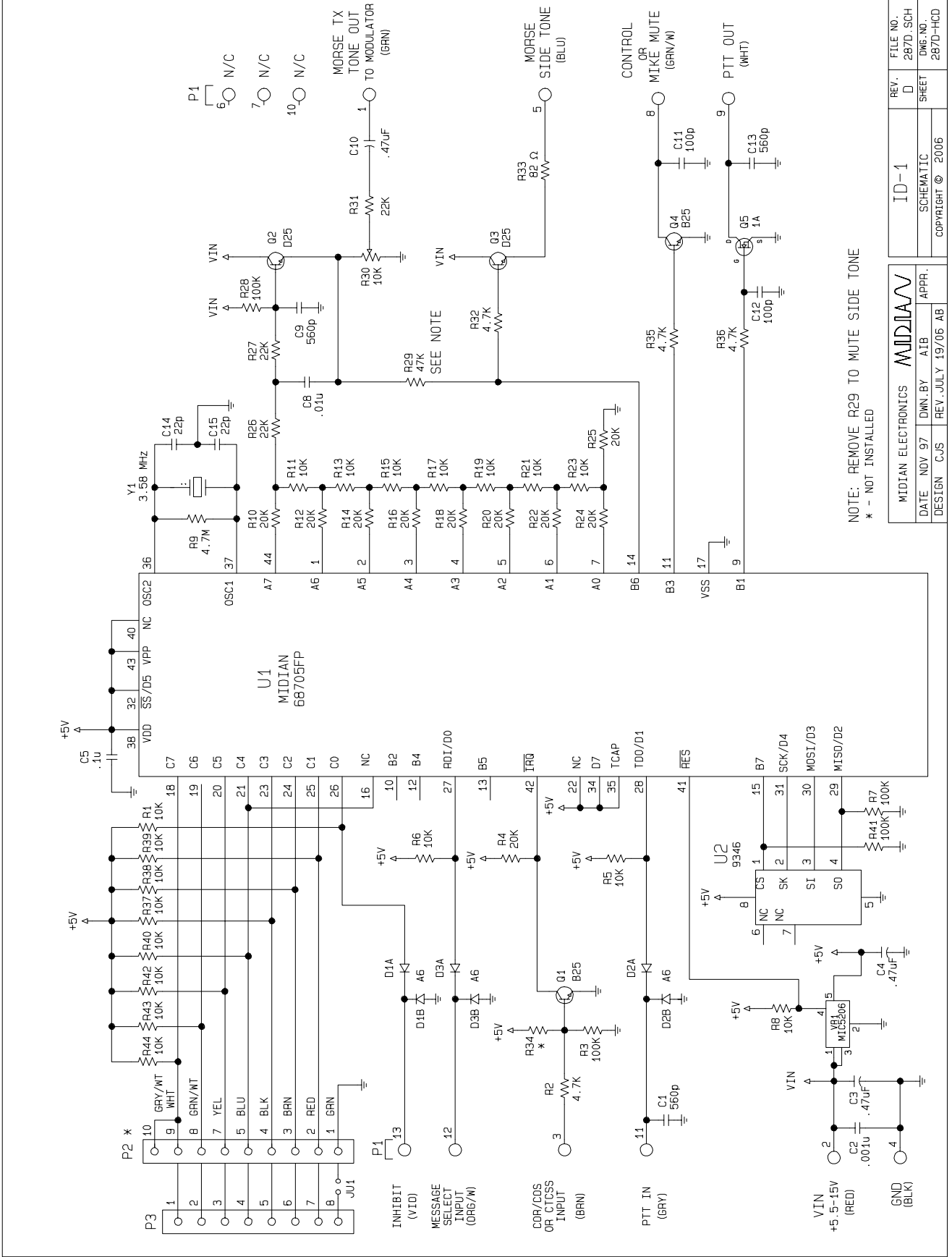

REV.	D	FILE NO.	ID-1
SHEET	1	DWG. NO.	287D-SCH
APPR.		SCHEMATIC	
REV. JULY 19/05 AB		COPYRIGHT © 2006	

MIDIAN ELECTRONICS  
DATE NOV 97  
DESIGN CJS  
DWN. BY AIB  
REV. JULY 19/05 AB

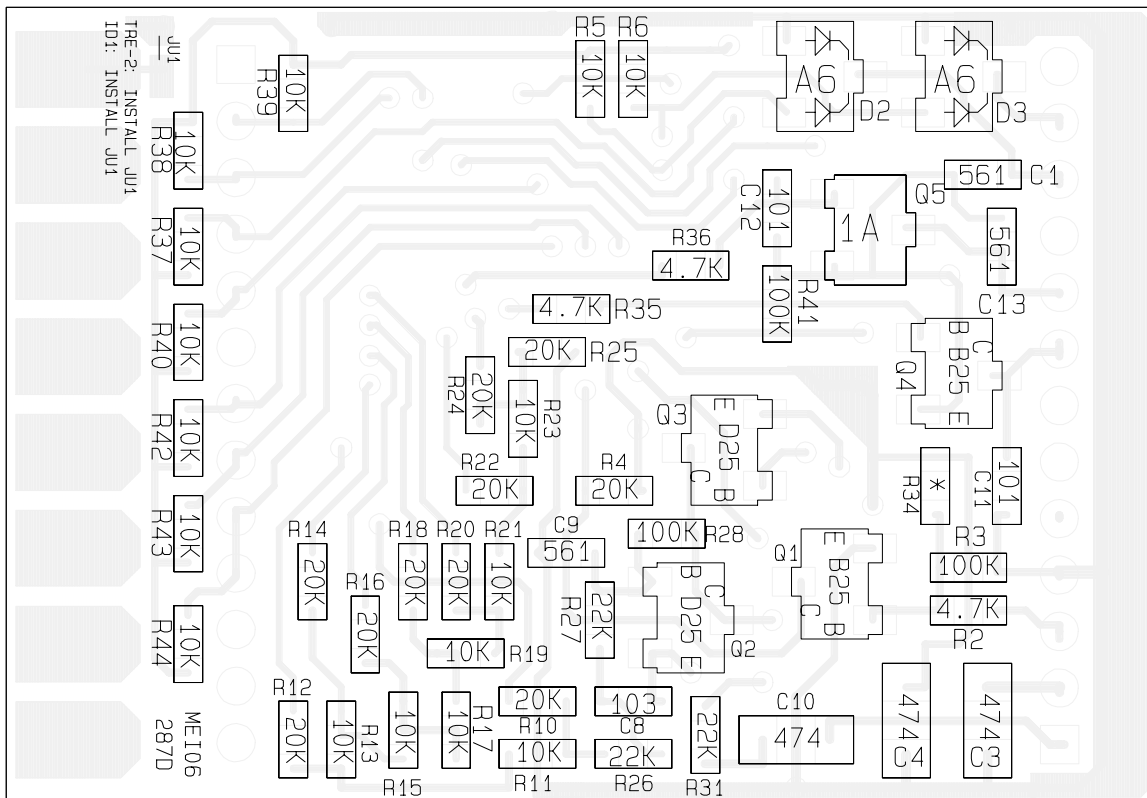
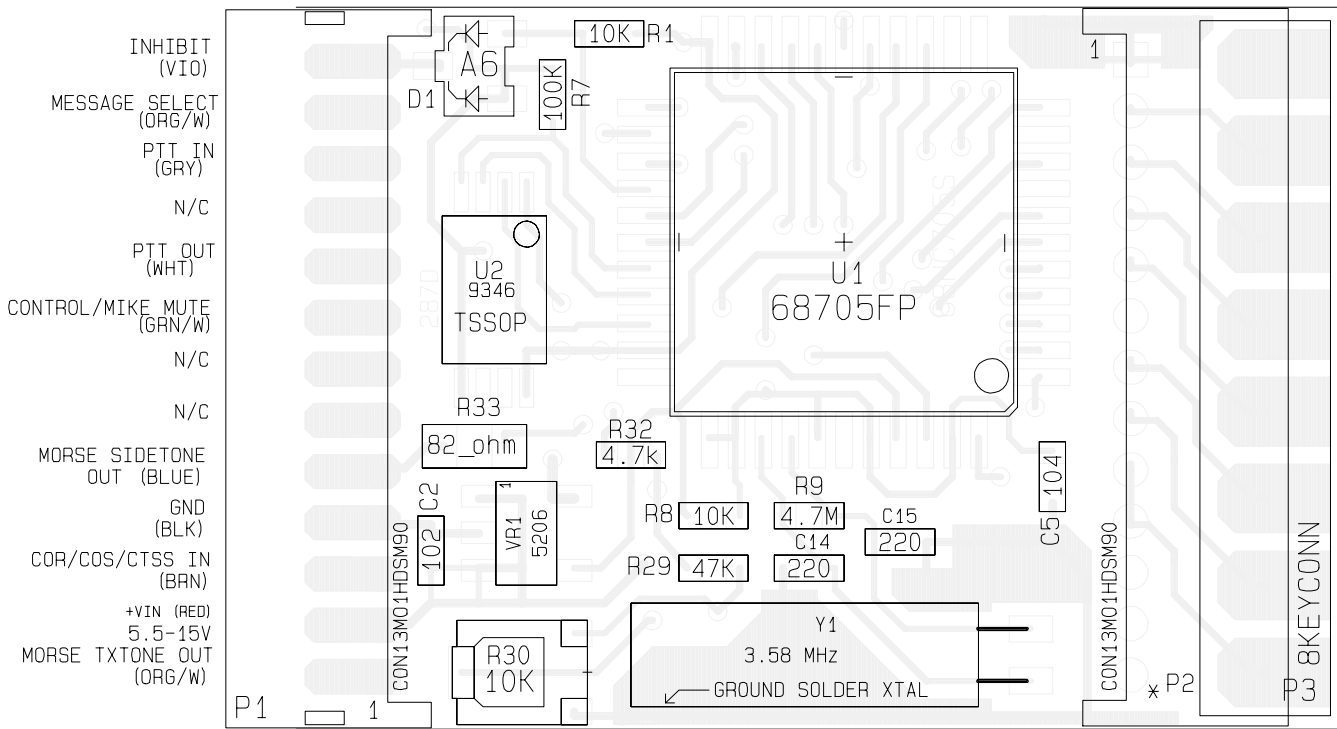

MIDIAN ELECTRONICS		MIDIAN	
DATE	NOV 97	DWN.BY	AB
DESIGN	CJS	REV.	JULY 19/06 AB
		APPR.	

ID-1
PICTORIAL
COPYRIGHT © 2006

REV.	D	FILE NO.	287D.SCH
SHEET		DWG. NO.	287D-HCD