



DT1050 DIGITALALKER™ Standard Vocabulary Kit

General Description

The DIGITALALKER™ is a speech synthesis system consisting of several N-channel MOS integrated circuits. It contains a speech processor chip (SPC) and speech ROM and when used with external filter, amplifier, and speaker, produces a system which generates high quality speech including the natural inflection and emphasis of the original speech. Male, female, and children's voices can be synthesized.

The SPC communicates with the speech ROM, which contains the compressed speech data as well as the frequency and amplitude data required for speech output. Up to 128k bits of speech data can be directly accessed.

With the addition of an external resistor, on-chip debounce is provided for use with a switch interface.

An interrupt is generated at the end of each speech sequence so that several sequences or words can be cascaded to form different speech expressions.

The DT1050 is a standard DIGITALALKER kit encoded with 137 separate and useful words, 2 tones, and 5 different silence durations. (See the Master Word List Table I). The words and tones have been assigned discrete addresses, making it possible to output single words or words concatenated into phrases or even sentences.

The "voice" output of the DT1050 is a highly intelligible male voice. The vocabulary is chosen so that it is applicable to many products and markets.

Features

- COPSTM and MICROBUS™ compatible
- Designed to be easily interfaced to other popular microprocessors
- 144 addressable expressions, including numbers
- Natural inflection and emphasis of original speech
- Addresses 128k of ROM directly
- TTL compatible
- On-chip switch debounce for interfacing to manual switches independent of a microprocessor
- Interrupt capability for cascading words or phrases
- Crystal controlled or externally driven oscillator

Applications

- Telecommunications
- Appliance
- Automotive
- Teaching aids
- Consumer products
- Clocks
- Language translation
- Annunciators

Typical Applications

Minimum Configuration Using Switch Interface

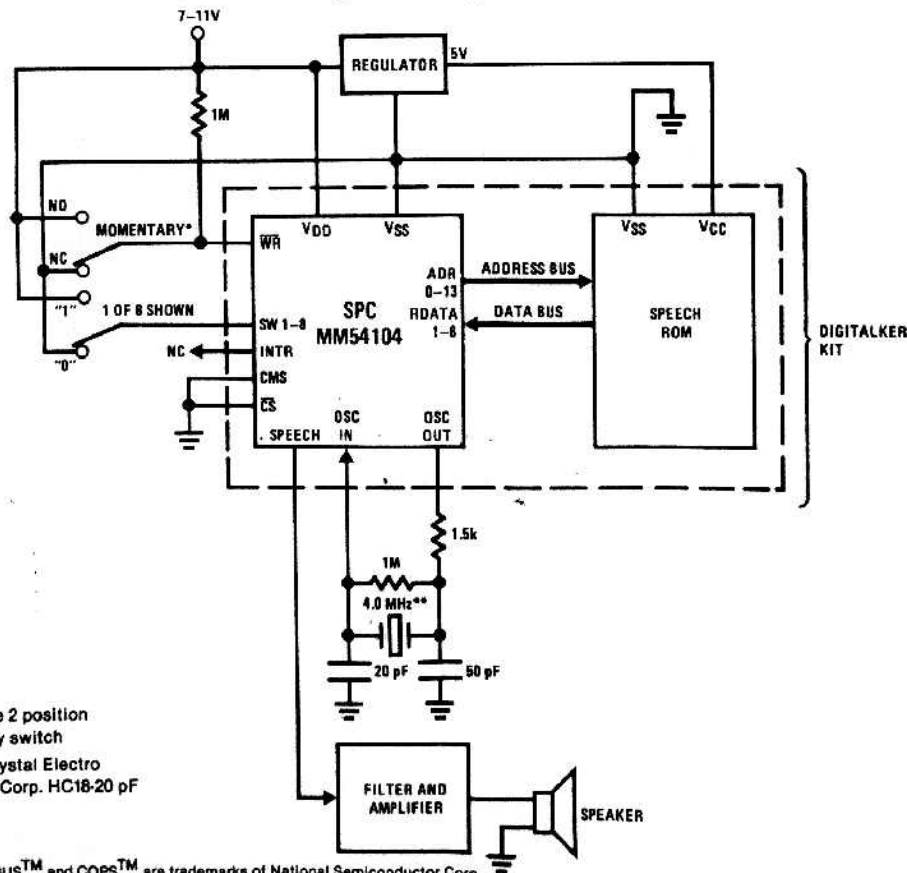

- * Single pole 2 position momentary switch
 ** 4.0 MHz crystal Electro Dynamics Corp. HC18-20 pF

Absolute Maximum Ratings*

Storage Temperature Range	- 65°C to + 150°C	Voltage at Any Pin	12V
Operating Temperature Range	0°C to 70°C	Operating Voltage Range, $V_{DD}-V_{SS}$	7V to 11V
$V_{DD}-V_{SS}$	12V	Lead Temperature (Soldering, 10 seconds)	300°C

DC Electrical Characteristics* $T_A = 0^\circ\text{C}$ to 70°C , $V_{DD} = 7\text{V}-11\text{V}$, $V_{SS} = 0\text{V}$, unless otherwise specified.

Symbol	Parameter	Conditions	Min	Typ	Max	Units
V_{IL}	Input Low Voltage		- 0.3		0.8	V
V_{IH}	Input High Voltage		2.0		V_{DD}	V
V_{OL}	Output Low Voltage	$I_{OL} = 1.6\text{ mA}$			0.4	V
V_{OH}	Output High Voltage	$I_{OH} = -100\ \mu\text{A}$	2.4		5.0	V
V_{ILX}	Clock Input Low Voltage		- 0.3		1.2	V
V_{IHx}	Clock Input High Voltage		5.5		V_{DD}	V
I_{DD}	Power Supply Current				45	mA
I_{IL}	Input Leakage				± 10	μA
I_{ILX}	Clock Input Leakage				± 10	μA
V_S	Silence Voltage			$0.45V_{DD}$		V
V_{OUT}	Peak to Peak Speech Output	$V_{DD} = 11\text{V}$		2.0		V
R_{EXT}	External Load on Speech Output	R_{EXT} Connected Between Speech Output and V_{SS}	50			k Ω

AC Electrical Characteristics* $T_A = 0^\circ\text{C}$ to 70°C , $V_{DD} = 7\text{V}-11\text{V}$, $V_{SS} = 0\text{V}$, unless otherwise specified.

Symbol	Parameter	Min	Max	Units
t_{aw}	CMS Valid to Write Strobe	350		ns
t_{csw}	Chip Select ON to Write Strobe	310		ns
t_{dw}	Data Bus Valid to Write Strobe	50		ns
t_{wa}	CMS Hold Time after Write Strobe	50		ns
t_{wd}	Data Bus Hold Time after Write Strobe	100		ns
t_{ww}	Write Strobe Width (50% Point)	430		ns
t_{red}	$\overline{\text{ROMEN}}$ ON to Valid ROM Data		2	μs
t_{wss}	Write Strobe to Speech Output Delay		410	μs
f_t	External Clock Frequency	3.92	4.08	MHz

Note: Rise and fall times (10% to 90%) of MICROBUS signals should be 50 ns maximum.
 *SPC characteristics only. ROM characteristics covered by separate data sheet for MM52164.

Timing Waveforms

Command Sequence

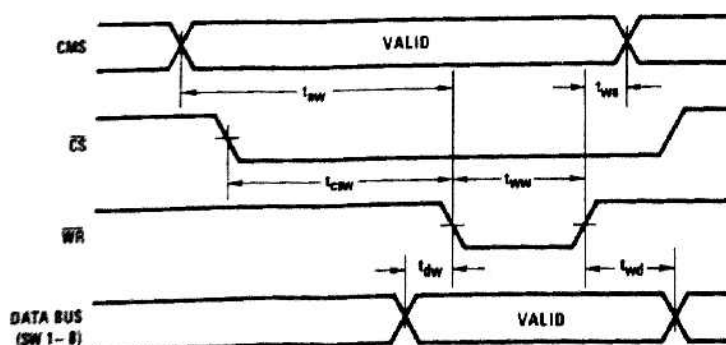

Timing Waveforms (Continued)

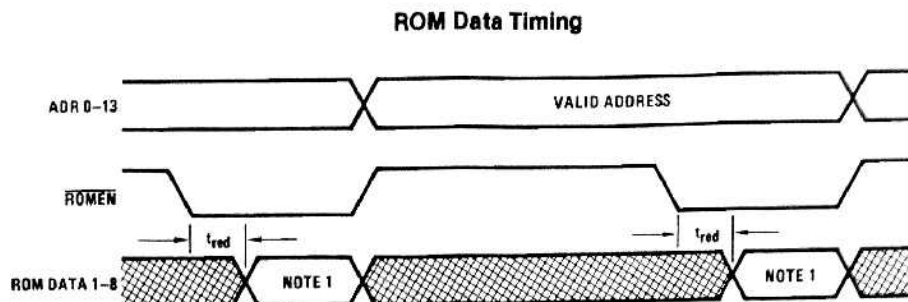

Note 1: ROM Data 1-8 can go valid any time after ADR 0-13 changes, however it must be valid within the t_{red} spec and remain valid until ROMEN goes high.

Functional Description

The following describes the function of all SPC input and output pins.

Note: In the following descriptions, a low represents a logic 0 (0.4V nominal), and a high represents a logic 1 (2.4V nominal).

INPUT SIGNALS

Chip Select (\overline{CS}): The SPC is selected when \overline{CS} is low. It is only necessary to have \overline{CS} low during a command to the SPC. It is not necessary to hold \overline{CS} low for the duration of the speech data.

Data Bus (SW 1-8): This is an 8-bit parallel data bus which contains the starting address of the speech data.

Data bus inputs SW 1-SW 8 accept an 8-bit binary address which is the address of the word which is to be "spoken" from the DIGITALKER output. See the Master Word List (Table I) for the complete listing of words and their respective addresses. If the entire word list is not used, unused inputs must be connected to V_{SS} .

Command Select (CMS): This line specifies the two commands to the SPC.

CMS	Function
0	Reset interrupt and start speech sequence
1	Reset interrupt only

Write Strobe (\overline{WR}): This line latches the starting address (SW 1-SW 8) into a register. On the rising edge of the \overline{WR} , the SPC starts execution of the command specified by CMS. The command sequence is shown in the timing waveform section. If a command to start a new speech sequence is issued during a speech sequence, the new speech sequence will be started immediately. When connecting \overline{WR} to a switch, it must be a single pole 2 position switch as shown on page 1.

ROM Data (RDATA 1-8): This is an 8-bit parallel data bus which contains the speech data from the speech ROM.

OUTPUT SIGNALS

Interrupt (INTR): This signal goes high at the completion of any speech sequence. It is reset by the next valid command. It is also reset at power up.

ROM Address (ADR 0-ADR 13): This is a 14-bit parallel bus that supplies the address of the speech data to the speech ROM.

ROM Enable (\overline{ROMEN}): For low power applications, this line can be used to drive a transistor that switches the supply for static speech ROMs. See ROM data timing.

Speech Output (Speech Out): This is the analog output that represents the speech data. See frequency response section.

INPUT/OUTPUT SIGNALS

Clock Input/Output (OSC IN, OSC OUT): These two pins connect the main timing reference (crystal) to the SPC.

PHRASE QUALITY

In normal human speech, the brain puts durations of silence between the words to make the sentence flow smoothly. Since several durations of silence are provided in the Master Word List, the actual quality of any phrase can be significantly improved by adding durations of silence (also assigned addresses) between the words. As one thinks about how the phrase is actually spoken, one might assume the approximate duration of silence between each word, and insert the closest duration of silence from the word list. A hint in this area would be that for words beginning with the letters, K, T, P, B, D, and G insert 80 milliseconds silence prior to the words, and for words ending in the same letters as above, 40 milliseconds silence following the word is recommended.

Functional Description (Continued)

TABLE I. DT1050 MASTER WORD LIST

Word	8-Bit Binary Address			8-Bit Binary Address			8-Bit Binary Address	
	SW 8	SW 1		SW 8	SW 1		SW 8	SW 1
THIS IS DIGITALKER	0	0	Q	0	0	IS	0	1
ONE	0	0	R	0	0	IT	0	1
TWO	0	0	S	0	0	KILO	0	1
THREE	0	0	T	0	0	LEFT	0	1
FOUR	0	0	U	0	1	LESS	0	1
FIVE	0	0	V	0	1	LESSER	0	1
SIX	0	0	W	0	1	LIMIT	0	1
SEVEN	0	0	X	0	1	LOW	0	1
EIGHT	0	0	Y	0	1	LOWER	0	1
NINE	0	0	Z	0	1	MARK	0	1
TEN	0	0	AGAIN	0	1	METER	0	1
ELEVEN	0	0	AMPERE	0	1	MILE	0	1
TWELVE	0	0	AND	0	1	MILLI	0	1
THIRTEEN	0	0	AT	0	1	MINUS	0	1
FOURTEEN	0	0	CANCEL	0	1	MINUTE	0	1
FIFTEEN	0	0	CASE	0	1	NEAR	0	1
SIXTEEN	0	0	CENT	0	1	NUMBER	0	1
SEVENTEEN	0	0	400HERTZ TONE	0	1	OF	0	1
EIGHTEEN	0	0	80HERTZ TONE	0	1	OFF	0	1
NINETEEN	0	0	20MS SILENCE	0	1	ON	0	1
TWENTY	0	0	40MS SILENCE	0	1	OUT	0	1
THIRTY	0	0	80MS SILENCE	0	1	OVER	0	1
FORTY	0	0	160MS SILENCE	0	1	PARENTHESIS	0	1
FIFTY	0	0	320MS SILENCE	0	1	PERCENT	0	1
SIXTY	0	0	CENTI	0	1	PLEASE	0	1
SEVENTY	0	0	CHECK	0	1	PLUS	0	1
EIGHTY	0	0	COMMA	0	1	POINT	0	1
NINETY	0	0	CONTROL	0	1	POUND	0	1
HUNDRED	0	0	DANGER	0	1	PULSES	0	1
THOUSAND	0	0	DEGREE	0	1	RATE	0	1
MILLION	0	0	DOLLAR	0	1	RE	0	1
ZERO	0	0	DOWN	0	1	READY	0	1
A	0	0	EQUAL	0	1	RIGHT	1	0
B	0	0	ERROR	0	1	SS (Note 1)	1	0
C	0	0	FEET	0	1	SECOND	1	0
D	0	0	FLOW	0	1	SET	1	0
E	0	0	FUEL	0	1	SPACE	1	0
F	0	0	GALLON	0	1	SPEED	1	0
G	0	0	GO	0	1	STAR	1	0
H	0	0	GRAM	0	1	START	1	0
I	0	0	GREAT	0	1	STOP	1	0
J	0	0	GREATER	0	1	THAN	1	0
K	0	0	HAVE	0	1	THE	1	0
L	0	0	HIGH	0	1	TIME	1	0
M	0	0	HIGHER	0	1	TRY	1	0
N	0	0	HOUR	0	1	UP	1	0
O	0	0	IN	0	1	VOLT	1	0
P	0	0	INCHES	0	1	WEIGHT (Note 2)	1	0

Note 1: "SS" makes any singular word plural

Note 2: Address 143 is the last legal address in this particular word list. Exceeding address 143 will produce pieces of unintelligible invalid speech data.

Crystal Circuit Information

Typical Crystal Oscillator Network

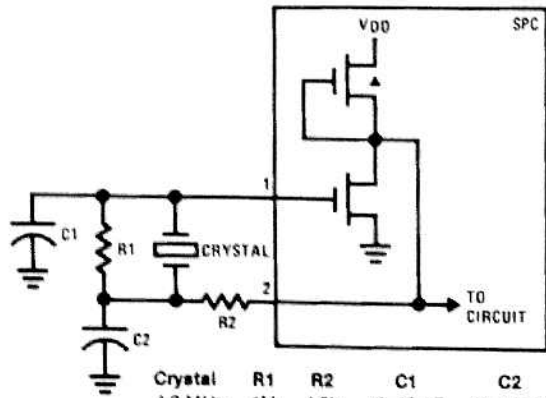

Crystal 4.0 MHz
 R1 1M
 R2 1.5k
 C1 10-30 pF
 C2 40-60 pF

(4.0 MHz crystal manufactured by Electro Dynamics Corp. P/N HC18-20 pF)

External Clock Input (4.0 MHz)

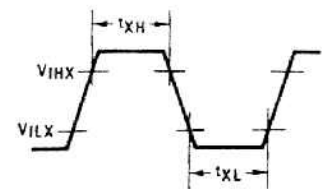
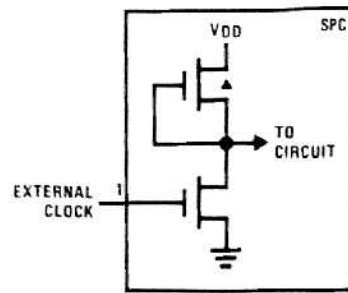

Timing	Min	Units
t _{XH}	100	ns
t _{XL}	100	ns

SPC Block and Connection Diagrams

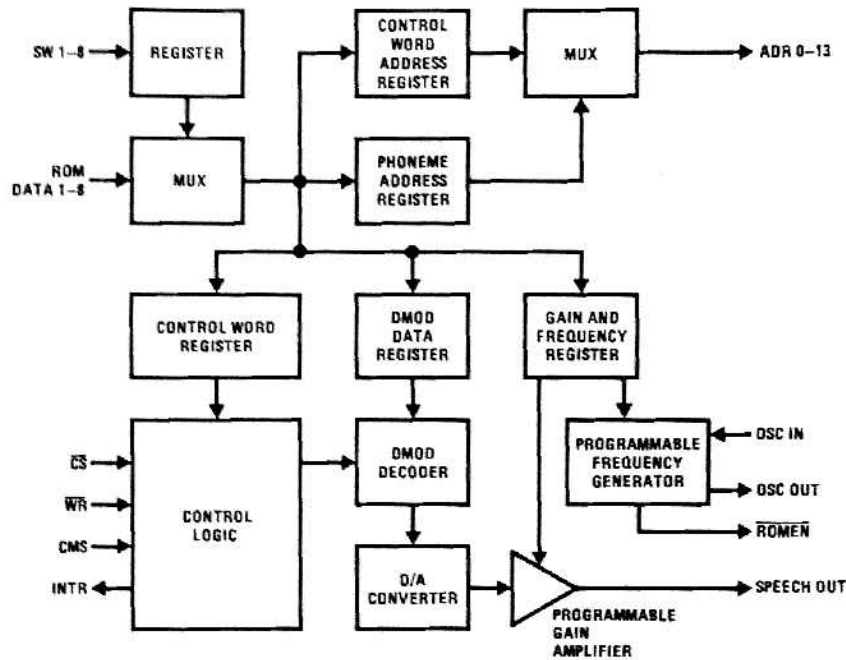

Dual-In-Line Package

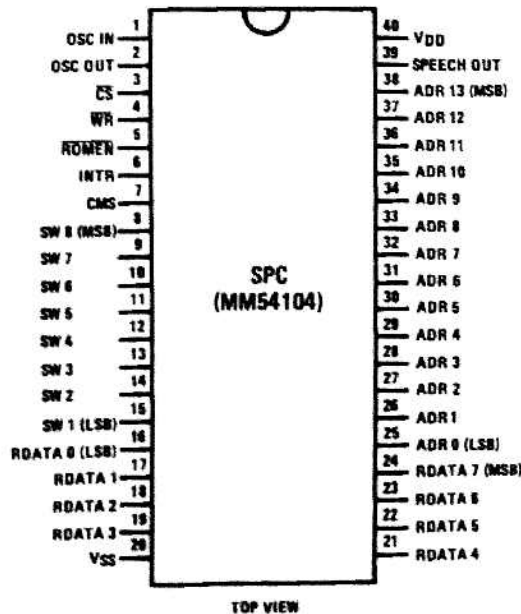

Dual-In-Line Package

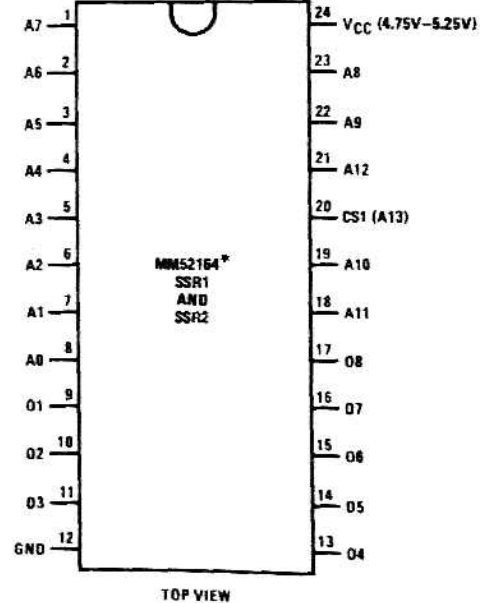

* For specific ROM device information, see MM52164 data sheet.

Recommended Schematic Diagram

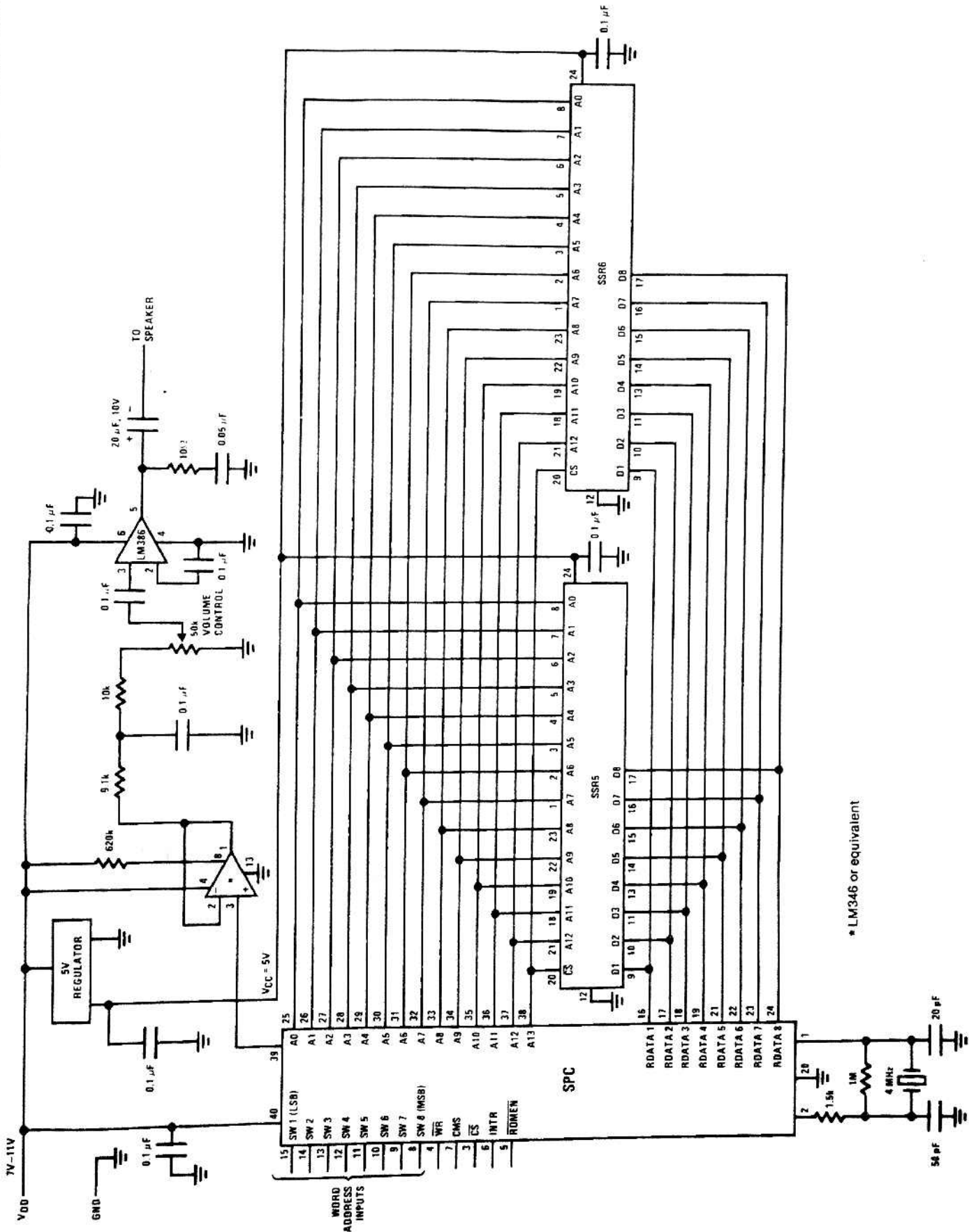

* LM386 or equivalent

Applications Information

Frequency Response of Combined Amplifier and Speaker

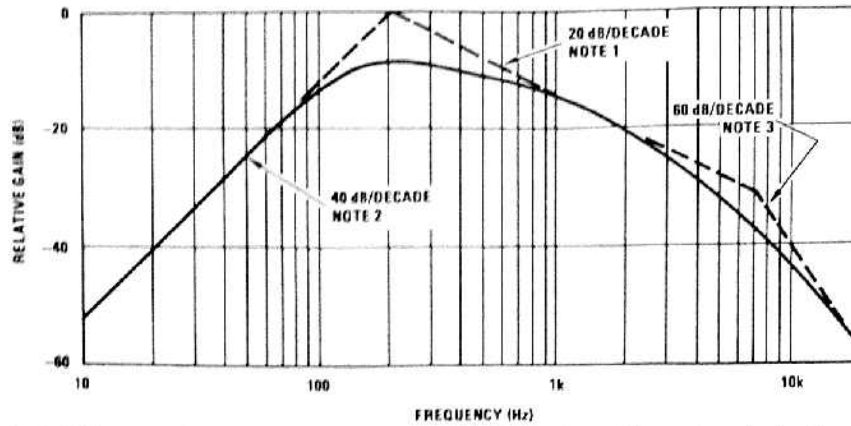

Note 1: This curve is the desired response of the entire audio system including speaker. Minimum response is a low pass filter with a cutoff frequency of 200 Hz. For an audio system with a natural cutoff frequency around 200 Hz, this filter can be eliminated. This cutoff frequency may be tuned for the particular voice being synthesized. For a low pitched male voice it may be 100 Hz, while for a high pitched female or child's voice it might be 300 Hz.

Note 2: This is optional filtering that can be eliminated by proper selection of the speaker. If this 2 pole response is electronically produced, it should be adjusted as described in Note 1.

Note 3: This is optional filtering that can be eliminated for simpler systems. The acceptable range for this cutoff frequency is 6000 Hz-8000 Hz.

Typical Applications (Continued)

DIGITAL TALKER System Using COP420 Interface

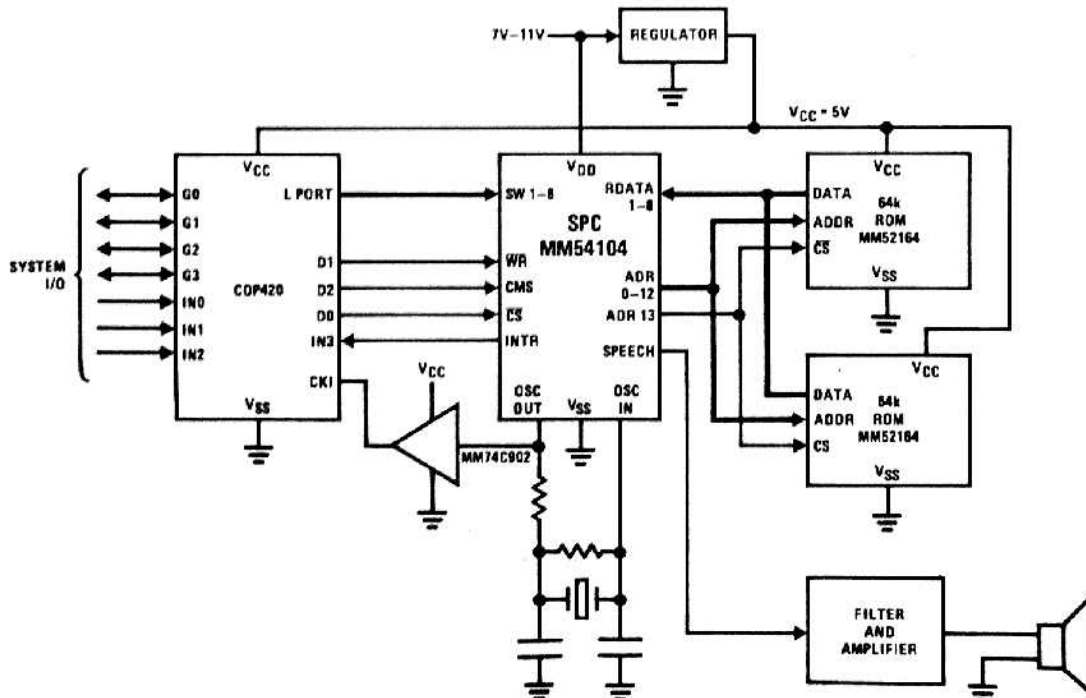

Minimum Filter Circuit

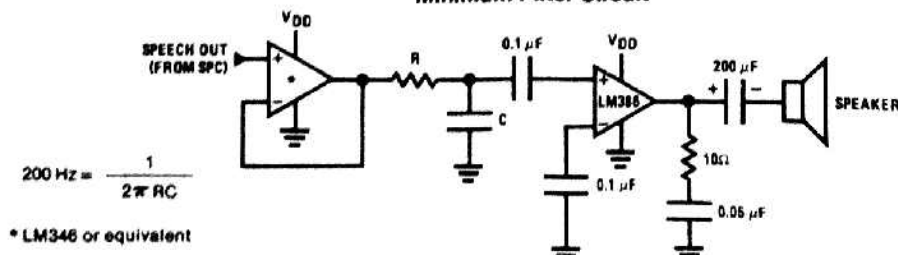

Typical Applications (Continued)

Filter Circuit to Produce Maximum Frequency Response

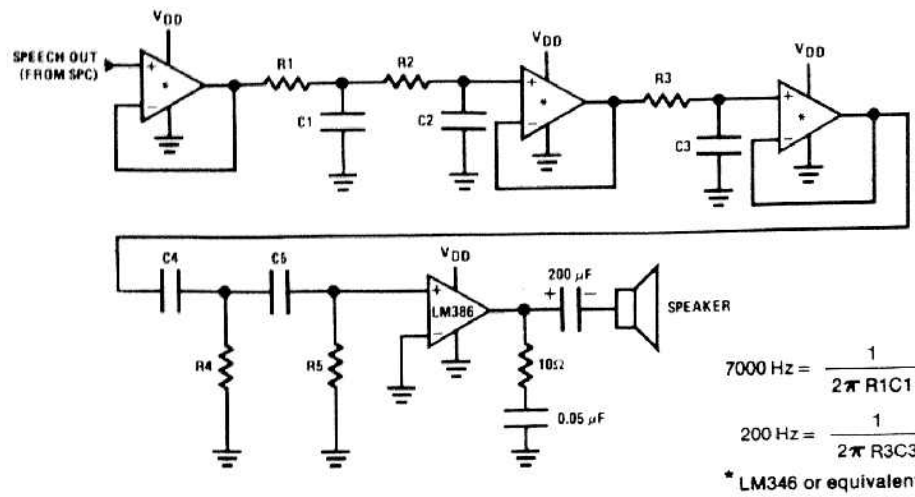

$$7000 \text{ Hz} = \frac{1}{2\pi R1C1} = \frac{1}{2\pi R2C2}$$

$$200 \text{ Hz} = \frac{1}{2\pi R3C3} = \frac{1}{2\pi R4C4} = \frac{1}{2\pi R5C5}$$

* LM346 or equivalent

DIGITAL TALKER System Utilizing MICROBUS™ Interface

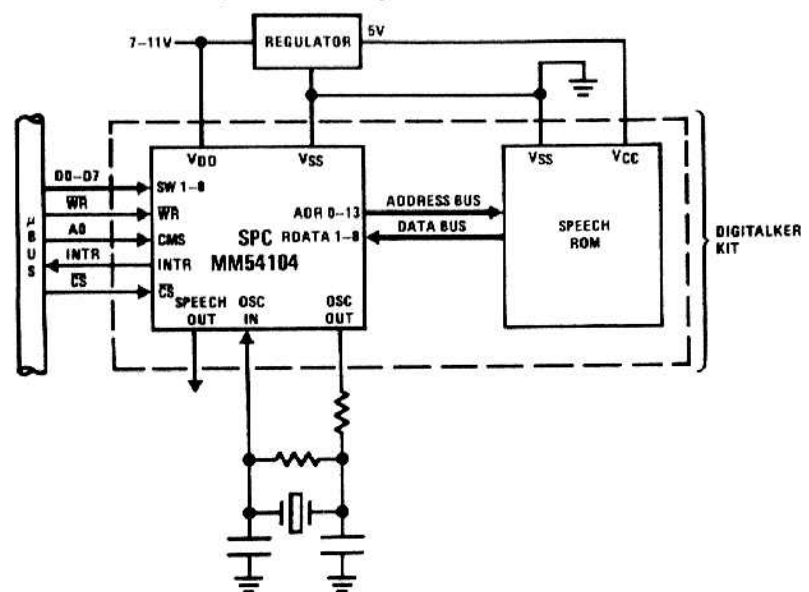

Low Power Configuration Using Static ROM

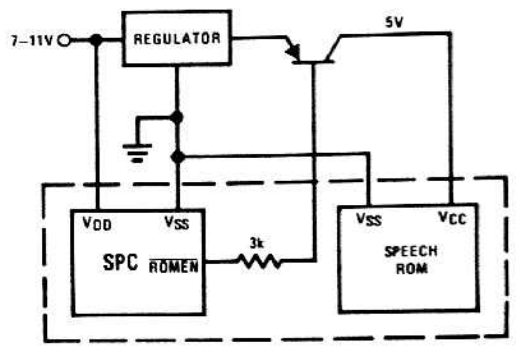

Physical Dimensions inches (millimeters)

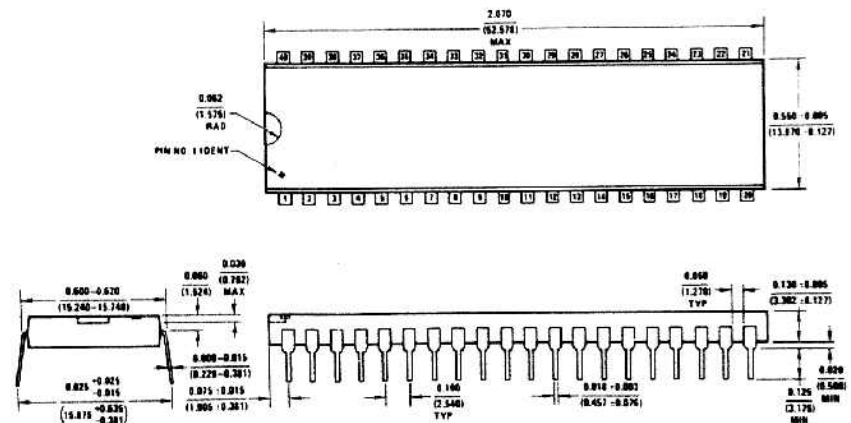

Molded Dual-In-Line Package (N)
NS Package Number N40A



National Semiconductor Corporation
2900 Semiconductor Drive
Santa Clara, California 95051
Tel.: (408)737-5000
TWX: (910)339-9240

National Semiconductor GmbH
Eisenheimerstrasse 61/11
8000 München 21
West Germany
Tel.: (089)576091
Telex: 05-22772

NS International Inc., Japan
Miyake Building
1-9 Yotsuya, Shinjuku-ku 160
Tokyo, Japan
Tel.: (03)355-3711
TWX: 232-2015 NSCJ-J

National Semiconductor (Hong Kong) Ltd.
8th Floor,
Cheung Kong Electronic Bldg.
4 Hing Yip Street
Kwun Tong
Kowloon, Hong Kong
Tel.: 3-899235
Telex: 43866 NSEHK HX
Cable: NATSEMI

NS Electronics De Brasil
Avda Brigadero Faria Lima 844
11 Andar Conjunto 1104
Jardim Paulistano
Sao Paulo, Brasil
Telex:
1121008 CABINE SAO PAULO

NS Electronics Pty. Ltd.
Cnr. Stud Rd. & Mtn Highway
Bayswater, Victoria 3153
Australia
Tel.: 03-729-6333
Telex: 32096

Typical Applications (Continued)

Filter Circuit to Produce Maximum Frequency Response

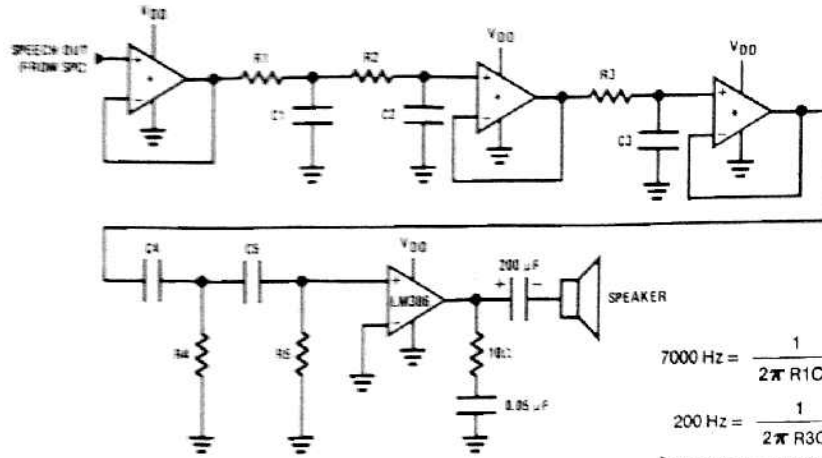

$$7000 \text{ Hz} = \frac{1}{2\pi R1C1} = \frac{1}{2\pi R2C2}$$

$$200 \text{ Hz} = \frac{1}{2\pi R3C3} = \frac{1}{2\pi R4C4} = \frac{1}{2\pi R5C5}$$

* LM346 or equivalent

DIGITALTALKER System Utilizing MICROBUS™ Interface

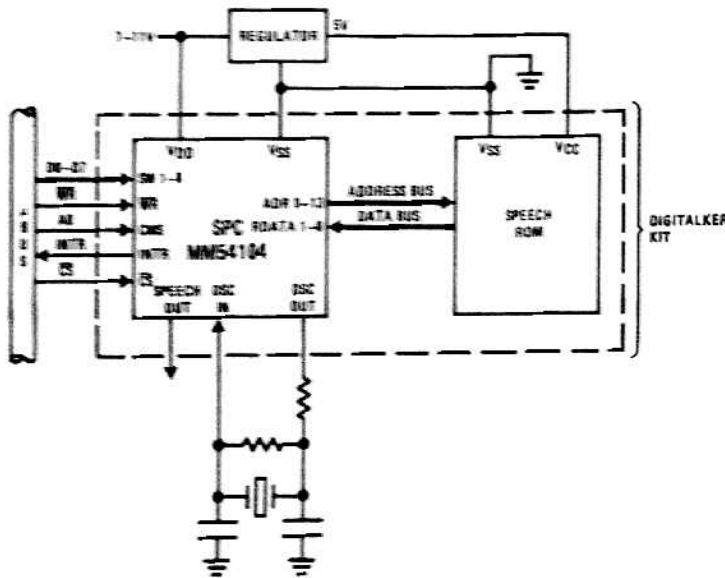

Low Power Configuration Using Static ROM

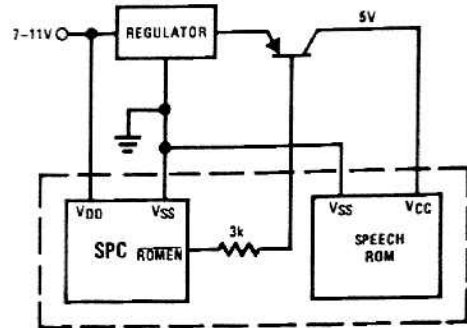

Physical Dimensions inches (millimeters)

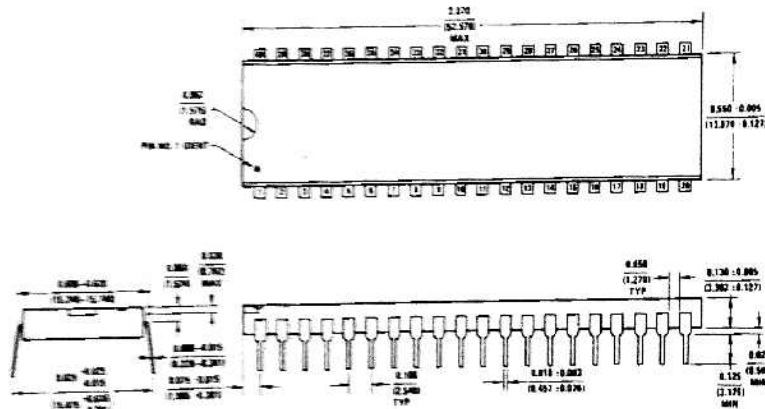

Molded Dual-In-Line Package (N) NS Package Number N40A



National Semiconductor Corporation
2500 Semiconductor Drive
Santa Clara, California 95051
Tel.: (408) 737-3300
TWX: (910) 326-3540

National Semiconductor GmbH
Eisenheimerstrasse 61/1
8030 München 21
West Germany
Tel.: (089) 76201
Telex: 65 21772

NS International Inc., Japan
Miyake Building
1-3 Yotsuya, Shinjuku-ku 160
Tokyo, Japan
Tel.: (03) 354-3711
TWX: 232-2015 NSCJ-J

National Semiconductor (Hong Kong) Ltd.
8th Floor,
Cheung Kong Electronic Bldg
4 Hing Yip Street
Kwun Tong
Kowloon, Hong Kong
Tel.: 3-899235
Telex: 43866 NSEHK HX
Cable: NATSEMI

NS Electronics Do Brasil
Avda Brigadeiro Faria Lima 844
11 Andar Conjunto 1104
Jardim Paulistano
Sao Paulo, Brasil
Telex:
1121008 CABINE SAO PAULO

NS Electronics Pty. Ltd.
Cnr. Stud Rd. & Mtn. Highway
Bayswater, Victoria 3153
Australia
Tel.: 03-729-6333
Telex: 32096



DT1056/DT1057 DIGITALALKER™ Standard Vocabulary Kit

General Description

The DIGITALALKER™ is a speech synthesis system consisting of several N-channel MOS integrated circuits. It contains a speech processor chip (SPC) and speech ROM and when used with external filter, amplifier, and speaker, produces a system which generates high quality speech including the natural inflection and emphasis of the original speech. Male, female, and children's voices can be synthesized.

The SPC communicates with the speech ROM, which contains the compressed speech data as well as the frequency and amplitude data required for speech output. Up to 128k bits of speech data can be directly accessed.

With the addition of an external resistor, on-chip debounce is provided for use with a switch interface.

An interrupt is generated at the end of each speech sequence so that several sequences or words can be cascaded to form different speech expressions.

The DT1056/DT1057 is a standard DIGITALALKER kit encoded with 131 separate and useful words (see the Master Word List Table I) and when used with the DT1050 Standard Vocabulary Kit, provides a library of 274 useful words. The words have been assigned discrete addresses, making it possible to output single words or words concatenated into phrases or even sentences.

The "voice" output of the DT1056/DT1057 is a highly intelligible male voice. The vocabulary is chosen so that it is applicable to many products and markets.

Features

- Easily adaptable to DT1050 Standard Vocabulary Kit
- 131 useful words
- COPS™ and MICROBUS™ compatible
- Designed to be easily interfaced to other popular microprocessors
- Natural inflection and emphasis of original speech
- Addresses 128k bits of ROM directly
- TTL compatible
- On-chip switch debounce for interfacing to manual switches independent of a microprocessor
- Interrupt capability for cascading words or phrases
- Crystal controlled or externally driven oscillator
- Available in complete kit (DT1056) or speech ROMs only (DT1057)

Applications

- Telecommunications
- Appliance
- Automotive
- Teaching aids
- Consumer products
- Clocks
- Language translation
- Annunciators

Typical Applications

Minimum Configuration Using Switch Interface

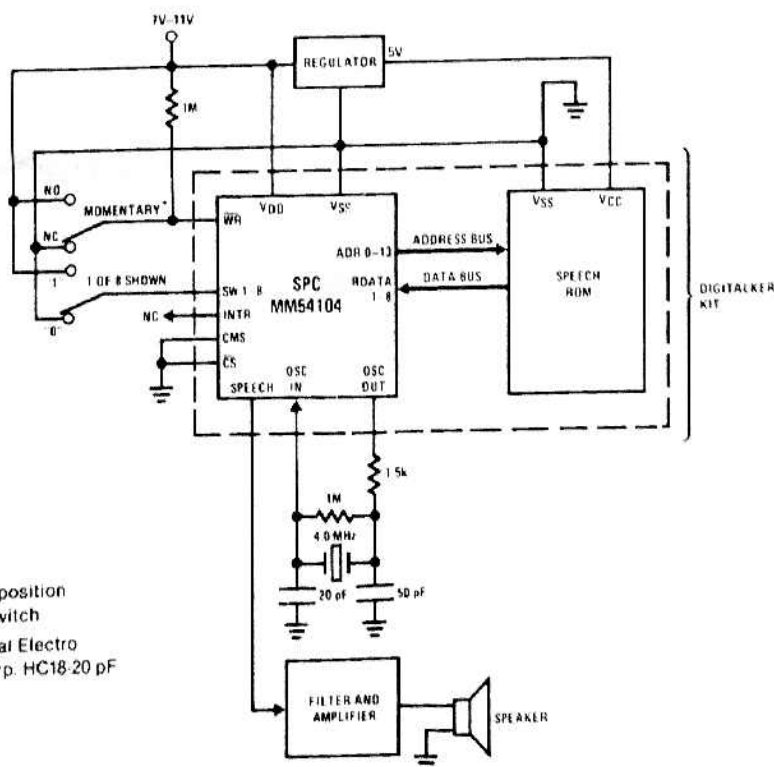

* Single pole 2 position momentary switch
 * 4.0 MHz crystal Electro Dynamics Corp. HC18-20 pF

DT1056/DT1057 DIGITALALKER™ Standard Vocabulary Kit

Absolute Maximum Ratings*

Storage Temperature Range	-65°C to +150°C	Voltage at Any Pin	12V
Operating Temperature Range	0°C to 70°C	Operating Voltage Range, $V_{DD}-V_{SS}$	7V to 11V
$V_{DD}-V_{SS}$	12V	Lead Temperature (Soldering, 10 seconds)	300°C

DC Electrical Characteristics* $T_A = 0^\circ\text{C}$ to 70°C , $V_{DD} = 7\text{V}-11\text{V}$, $V_{SS} = 0\text{V}$, unless otherwise specified.

Symbol	Parameter	Conditions	Min	Typ	Max	Units
V_{IL}	Input Low Voltage		-0.3		0.8	V
V_{IH}	Input High Voltage		2.0		V_{DD}	V
V_{OL}	Output Low Voltage	$I_{OL} = 1.6\text{ mA}$			0.4	V
V_{OH}	Output High Voltage	$I_{OH} = -100\ \mu\text{A}$	2.4		5.0	V
V_{ILX}	Clock Input Low Voltage		-0.3		1.2	V
V_{IHx}	Clock Input High Voltage		5.5		V_{DD}	V
I_{DD}	Power Supply Current				45	mA
I_{IL}	Input Leakage				± 10	μA
I_{ILX}	Clock Input Leakage				± 10	μA
V_S	Silence Voltage			$0.45V_{DD}$		V
V_{OUT}	Peak to Peak Speech Output	$V_{DD} = 11\text{V}$		2.0		V
R_{EXT}	External Load on Speech Output	R_{EXT} Connected Between Speech Output and V_{SS}	50			k Ω

AC Electrical Characteristics* $T_A = 0^\circ\text{C}$ to 70°C , $V_{DD} = 7\text{V}-11\text{V}$, $V_{SS} = 0\text{V}$, unless otherwise specified.

Symbol	Parameter	Min	Max	Units
t_{aw}	CMS Valid to Write Strobe	350		ns
t_{csw}	Chip Select ON to Write Strobe	310		ns
t_{dw}	Data Bus Valid to Write Strobe	50		ns
t_{wa}	CMS Hold Time after Write Strobe	50		ns
t_{wd}	Data Bus Hold Time after Write Strobe	100		ns
t_{ww}	Write Strobe Width (50% Point)	430		ns
t_{red}	ROMEN ON to Valid ROM Data		2	μs
t_{wss}	Write Strobe to Speech Output Delay		410	μs
f_t	External Clock Frequency	3.92	4.08	MHz

Note: Rise and fall times (10% to 90%) of MICROBUS signals should be 50 ns maximum.

*SPC characteristics only. ROM characteristics covered by separate data sheet for MM52164.

Timing Waveforms

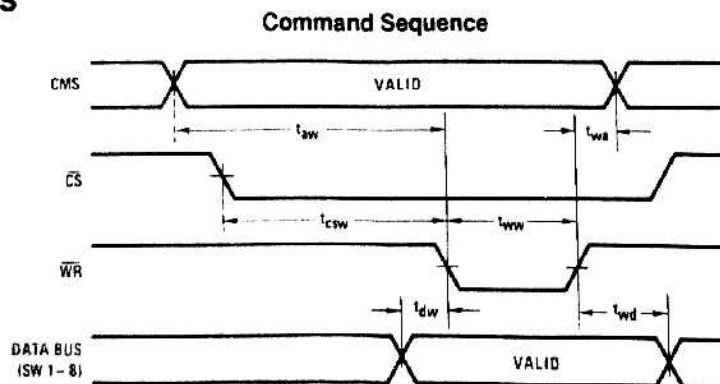

Timing Waveforms (Continued)

ROM Data Timing

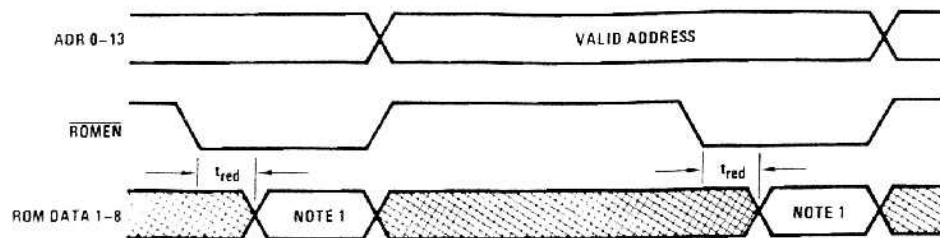

Note 1: ROM Data 1-8 can go valid any time after ADR0-13 changes, however it must be valid within the t_{red} spec and remain valid until \overline{ROMEN} goes high.

Functional Description

The following describes the function of all SPC input and output pins.

Note: In the following descriptions, a low represents a logic 0 (0.4V nominal), and a high represents a logic 1 (2.4V nominal).

INPUT SIGNALS

Chip Select (\overline{CS}): The SPC is selected when \overline{CS} is low. It is only necessary to have \overline{CS} low during a command to the SPC. It is not necessary to hold \overline{CS} low for the duration of the speech data.

Data Bus (SW 1-8): This is an 8-bit parallel data bus which contains the starting address of the speech data.

Data bus inputs SW 1-SW 8 accept an 8-bit binary address which is the address of the word which is to be "spoken" from the DIGITALKER output. See the Master Word List (Table I) for the complete listing of words and their respective addresses. If the entire word list is not used, unused inputs must be connected to V_{SS} .

Command Select (CMS): This line specifies the two commands to the SPC.

CMS	Function
0	Reset interrupt and start speech sequence
1	Reset interrupt only

Write Strobe (\overline{WR}): This line latches the starting address (SW 1-SW 8) into a register. On the rising edge of the \overline{WR} , the SPC starts execution of the command specified by CMS. The command sequence is shown in the timing waveform section. If a command to start a new speech sequence is issued during a speech sequence, the new speech sequence will be started immediately. When connecting \overline{WR} to a switch, it must be a single pole 2 position switch as shown on page 1.

ROM Data (RDATA 1-8): This is an 8-bit parallel data bus which contains the speech data from the speech ROM.

OUTPUT SIGNALS

Interrupt (INTR): This signal goes high at the completion of any speech sequence. It is reset by the next valid command. It is also reset at power up.

ROM Address (ADR 0-ADR 13): This is a 14-bit parallel bus that supplies the address of the speech data to the speech ROM.

ROM Enable (\overline{ROMEN}): For low power applications, this line can be used to drive a transistor that switches the supply for static speech ROMs. See ROM Data Timing.

Speech Output (Speech Out): This is the analog output that represents the speech data. See frequency response section.

INPUT/OUTPUT SIGNALS

Clock Input/Output (OSC IN, OSC OUT): These two pins connect the main timing reference (crystal) to the SPC.

PHRASE QUALITY

In normal human speech, the brain puts durations of silence between the words to make the sentence flow smoothly. Since several durations of silence are provided in the Master Word List, the actual quality of any phrase can be significantly improved by adding durations of silence (also assigned addresses) between the words. As one thinks about how the phrase is actually spoken, one might assume the approximate duration of silence between each word, and insert the closest duration of silence from the word list. A hint in this area would be that for words beginning with the letters, K, T, P, B, D, and G insert 80 milliseconds silence prior to the words, and for words ending in the same letters as above, 40 milliseconds silence following the word is recommended.

Functional Description (Continued)

TABLE I. DT1056/DT1057* MASTER WORD LIST

Word	8-Bit Binary Address		Word	8-Bit Binary Address		Word	8-Bit Binary Address	
	SW8	SW1		SW8	SW1		SW8	SW1
ABORT	00000000		FARAD	00101100		PER	01011000	
ADD	00000001		FAST	00101101		PICO	01011001	
ADJUST	00000010		FASTER	00101110		PLACE	01011010	
ALARM	00000011		FIFTH	00101111		PRESS	01011011	
ALERT	00000100		FIRE	00110000		PRESSURE	01011100	
ALL	00000101		FIRST	00110001		QUARTER	01011101	
ASK	00000110		FLOOR	00110010		RANGE	01011110	
ASSISTANCE	00000111		FORWARD	00110011		REACH	01011111	
ATTENTION	00001000		FROM	00110100		RECEIVE	01100000	
BRAKE	00001001		GAS	00110101		RECORD	01100001	
BUTTON	00001010		GET	00110110		REPLACE	01100010	
BUY	00001011		GOING	00110111		REVERSE	01100011	
CALL	00001100		HALF	00111000		ROOM	01100100	
CAUTION	00001101		HELLO	00111001		SAFE	01100101	
CHANGE	00001110		HELP	00111010		SECURE	01100110	
CIRCUIT	00001111		HERTZ	00111011		SELECT	01100111	
CLEAR	00010000		HOLD	00111100		SEND	01101000	
CLOSE	00010001		HOLD	00111101		SERVICE	01101001	
COMPLETE	00010010		INCORRECT	00111110		SIDE	01101010	
CONNECT	00010011		INCREASE	00111111		SLOW	01101011	
CONTINUE	00010100		INTRUDER	00111111		SLOWER	01101100	
COPY	00010101		JUST	01000000		SMOKE	01101101	
CORRECT	00010110		KEY	01000001		SOUTH	01101110	
DATE	00010111		LEVEL	01000010		STATION	01101111	
DAY	00011000		LOAD	01000011		SWITCH	01110000	
DECREASE	00011001		LOCK	01000100		SYSTEM	01110001	
DEPOSIT	00011010		MEG	01000101		TEST	01110010	
DIAL	00011011		MEGA	01000110		TH (NOTE 2)	01110011	
DIVIDE	00011100		MICRO	01000111		THANK	01110100	
DOOR	00011101		MORE	01001000		THIRD	01110101	
EAST	00011110		MOVE	01001001		THIS	01110110	
ED (NOTE 1)	00011111		NANO	01001010		TOTAL	01110111	
ED (NOTE 1)	00100000		NEED	01001011		TURN	01111000	
ED (NOTE 1)	00100001		NEXT	01001100		USE	01111001	
ED (NOTE 1)	00100010		NO	01001101		UTH (NOTE 3)	01111010	
EMERGENCY	00100011		NORMAL	01001110		WAITING	01111011	
END	00100100		NORTH	01001111		WARNING	01111100	
ENTER	00100101		NOT	01010000		WATER	01111101	
ENTRY	00100110		NOTICE	01010001		WEST	01111110	
ER	00100111		OHMS	01010010		SWITCH	01111111	
EVACUATE	00101000		ONWARD	01010011		WINDOW	10000000	
EXIT	00101001		OPEN	01010100		YES	10000001	
FAIL	00101010		OPERATOR	01010101		ZONE	10000010	
FAILURE	00101011		OR	01010110				
			PASS	01010111				

*DT1056 is a complete kit including MM54104 SPC, DT1057 is SSR5 and SSR6 speech ROMs only.

Note 1: "ED" is a suffix that can be used to make any present tense word become a past tense word. The way we say "ED," however does vary from one word to the next. For that reason, we have offered 4 different "ED" sounds. It is suggested that each "ED" be tested with the desired word for best quality results. Address 31 "ED" or 32 "ED" should be used with words ending in "T" or "D," such as exit or load. Address 34 "ED" should be used with words ending with soft sounds such as ask. Address 33 "ED" should be used with all other words.

Note 2: "TH" is a suffix that can be added to words like six, seven, eight to form adjective words like sixth, seventh, eighth.

Note 3: "UTH" is a suffix that can be added to words like twenty, thirty, forty to form adjective words like thirtieth, fortieth, etc.

Note 4: Address 130 is the last legal address in this particular word list. Exceeding address 130 will produce pieces of unintelligible invalid speech data.

Crystal Circuit Information

Typical Crystal Oscillator Network

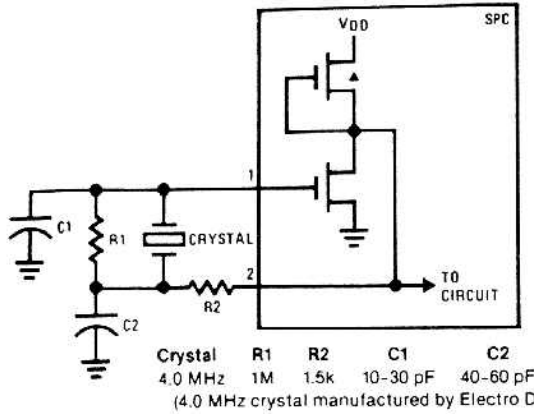

External Clock Input (4.0 MHz)

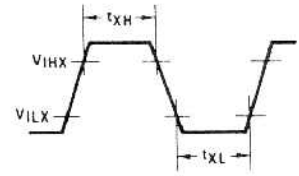
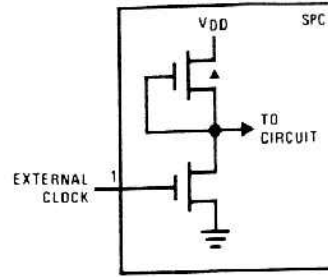

Timing	Min	Units
t _{XH}	100	ns
t _{XL}	100	ns

SPC Block and Connection Diagrams

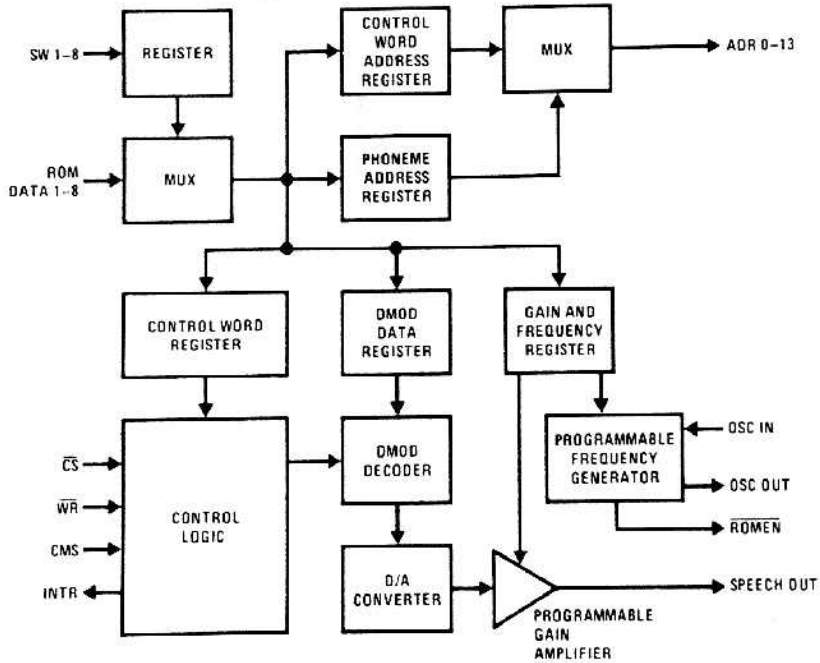

Dual-In-Line Package

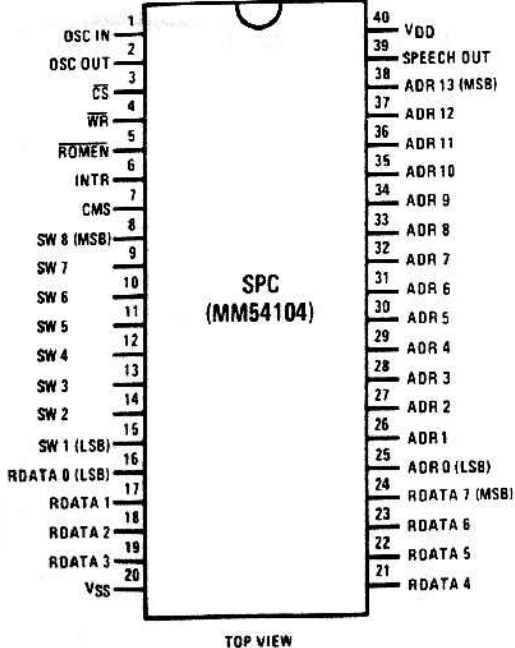

TOP VIEW

Dual-In-Line Package

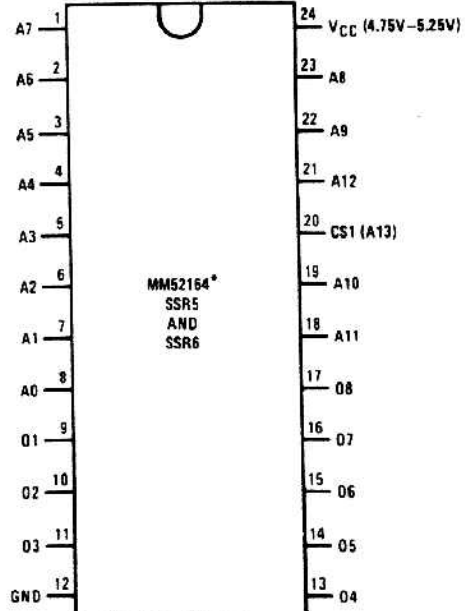

TOP VIEW

* For specific ROM device information, see MM52164 data sheet.

Recommended Schematic Diagram

