

SSC

SOLID-STATE COMMUNICATIONS, INC.
21060 Corsair Blvd. • Hayward, California 94545 U.S.A.
Telephone: (415) 785-4610 • Telex: 33-5384

OPERATING INSTRUCTIONS

TWO-TONE SEQUENTIAL ENCODER
MODEL 237 SERIES
BOARD ONLY & MOBILE

REV: MARCH 1983

I. GENERAL

The 237 series are universal 100 call two-tone sequential (1+1) encoders intended for use with the SSC Model 224 series of decoders and most all other industry manufactured two-tone sequential decoders.

The encoders may be easily field tuned to any ten first tone frequencies and any ten second tone frequencies as long as these frequencies are within bands selected separately for the first and second tone groups. Additionally, it is possible to select different tone lengths for each tone group. This provides a means to field custom configure the encoders to call any decoder in an existing system which uses any one of the existing industry standard coding schemes as long as it does not involve the use of an eleventh tone used in place of a sequentially repeated tone frequency. By reserving one unused frequency on each dial, 18 single burst tone calls may be obtained.

The first suffix letter in the model designation indicates electrical configuration with "A" for relay controlled output and "B" indicating solid state transmitter keying. The second suffix letter indicates mechanical configuration with "A" for board only and "Y" for board in mobile housing.

II. OPERATING SPECIFICATIONS

Electrical & Mechanical, (237 Series Encoders)

Format: Universally compatible two-tone sequential (1+1) or alternative Single Burst Tone
Number of Codes per Unit: 100 possible 1+1 calls or 18 possible single burst tone calls
Operating Frequency Range: 300Hz to 1600Hz and/or 800Hz to 3500Hz. 10 first and 10 second tones, each tone independently tunable within selected band for group.
Frequency Stability: $\pm 0.3\%$
Group Call: Not available on standard units
Length of Tones: 300ms to 3 sec. incl. initiate delay first tone. 120ms to 2.5 sec. second tone, selectable.
Intertone off time: No space between tones
Tone Level Differential: Within 3db
Signal Level: Adjustable up to 1VRMS output
Impedance: Unbalanced 600 ohms nominal during sequence, open circuit on stand-by (1K or 10K nominal for Model 237B)
Output Relay: Model 237A 1 Form "C" for keying transmitter. 1 Form "C" for switching audio path. (Model 237B replaces relay with open collector keying)

Indications: On pressing "call" button, LED illuminates, transmitter is keyed and tones sent. LED extinguishes at end of sequence
Controls: Code select rotary switches, "call" push button. External PTT control possible
Supply Voltage: 10.8V to 16VDC negative common
Current, Stand-by: 0.1Ma nominal (add 19ma for dial lighting)
Current, Maximum: 100Ma during sequence (add 19ma for dial lighting)
Temperature Range: -40°C to $+85^{\circ}\text{C}$. Vehicular environment
Enclosure Size: 3 1/8" X 4 1/16" D x 1 15/16" H plus bracket and cable
P.C. Board Size: 2 3/4" W x 3 1/2" L x 1" H excluding switch shafts and connector over hangs
Interconnect: Via 11 pin keyed connector and attached 4' cable

Options

- Option 1 - Factory Programming of codes (units supplied according to customer specified coding plan)
Option 2 - Two unit stacking Bracket (replaces standard mounting bracket)

III. MOUNTING CONSIDERATIONS

The "Y" housing is supplied with bracket and may be mounted almost anywhere including under-dash or on the fire wall of a vehicle or attached to the transmitting device in any installation.

The "A" P.C. Board version may be mounted within existing equipment on any flat surface measuring 3-1/2 by 2-1/2 inches via 3 nylon spacers and #4 screws with Kep-nuts, or through holes on a vertical panel by the switch shafts with nuts. Avoid mounting or running leads within high intensity R.F. fields such as found in the power amplifier compartment of a radio transmitter. If the encoder output is to feed a high impedance mic circuit, make the lead as short as possible and use a shielded cable if stray pick-up is encountered during microphone use. See the attached schematic for interconnection information. An optional stacking bracket is available for mounting both the 237AY encoder and the 224AY decoder as companion units.

CONTINUED ON PAGE 4

REPLACEMENT PARTS LIST

QTY	DESCRIPTION
1	CAPACITOR, .01 μ F, 12V, 20%, C. DISC.
1	1500 μ F, X7R
2	220PF, C.DISC.
1	.01 μ F, COG
1	10 μ F, 20%, TANT, 16V
2	.1 μ F, 25V, 20%, C. DISC.
2	.1 μ F, 20V, 10%, TANT, 16V
2	2.2 μ F, 10V, 20%, C. DISC.
2	CAPACITOR, .1 μ F, 12V, 20%, C. DISC.
5	DIODE, 1N914 OR EQUIV
1	OP. AMP, DIP, LM358H
1	OP. AMP, TLO84
1	C/MOS QUAD BILATERAL SW, CD4066AD
1	C/MOS NOR GATE QUAD 2 INPUT, CD400AD
10	MALE BEAD PIN (SHORT)
1	11 PIN CONN. LOCKING (MALE) (REMOVE PIN 7)
2	TRANSISTOR, 2N3904, NPN (TO 92 CASE)
1	TRANSISTOR, 2N3906, PNP (TO 92 CASE)
1	RELAY, 2 PNT, 120V, 5%, 1/4W, CF
1	RELAY, 2 PNT, 120V, 5%, 1/4W, CF
2	SWITCH, 12 POS, ROTARY, RCL II-X300B-12-1
1	SWITCH, PUSHBUTTON
1	VOLT REGULATOR, LM78L00
1	PC. BD.
2	SOCKET, 51P 2 POS. SAMTEC SS-102-12
20	TERMIN. BLOCK, 201, BUCKMAN, B99PBUK
1	RESISTOR, 30K, 5%, 1/4W, CF
1	1M
1	27K
1	390K
1	3K
1	82K
1	100K
1	4.3K
1	680 Ω
1	22K
1	1K
1	270K
1	1.5K
1	47K, 5%, 1/4W, CF
1	147K, 1%, MF, RN55D OR C
1	274K, 1%
1	732 Ω
1	RESISTOR, 15.4K, 1%, MF, RN55D OR C
1	POT, 10K, MEPCO, 8014 EMU103E1
237A	SAME AS 237A EXCEPT: DELETE CR6, R53, KI, ADD:
Q4	TRANSISTOR, 2N4401 (TO 92 CASE)
C14	CAPACITOR, 10 μ F, 20%, TANT, 16V
R60, S1	RESISTOR, 1K, 5%, 1/4W
R62, R4	RESISTOR, 10K, 5%, 1/4W
R56	RESISTOR, 390 Ω , 5%, 1/4W, CF
LED 2, 3	LED, YELLOW, DIALIGHT, 521-9211

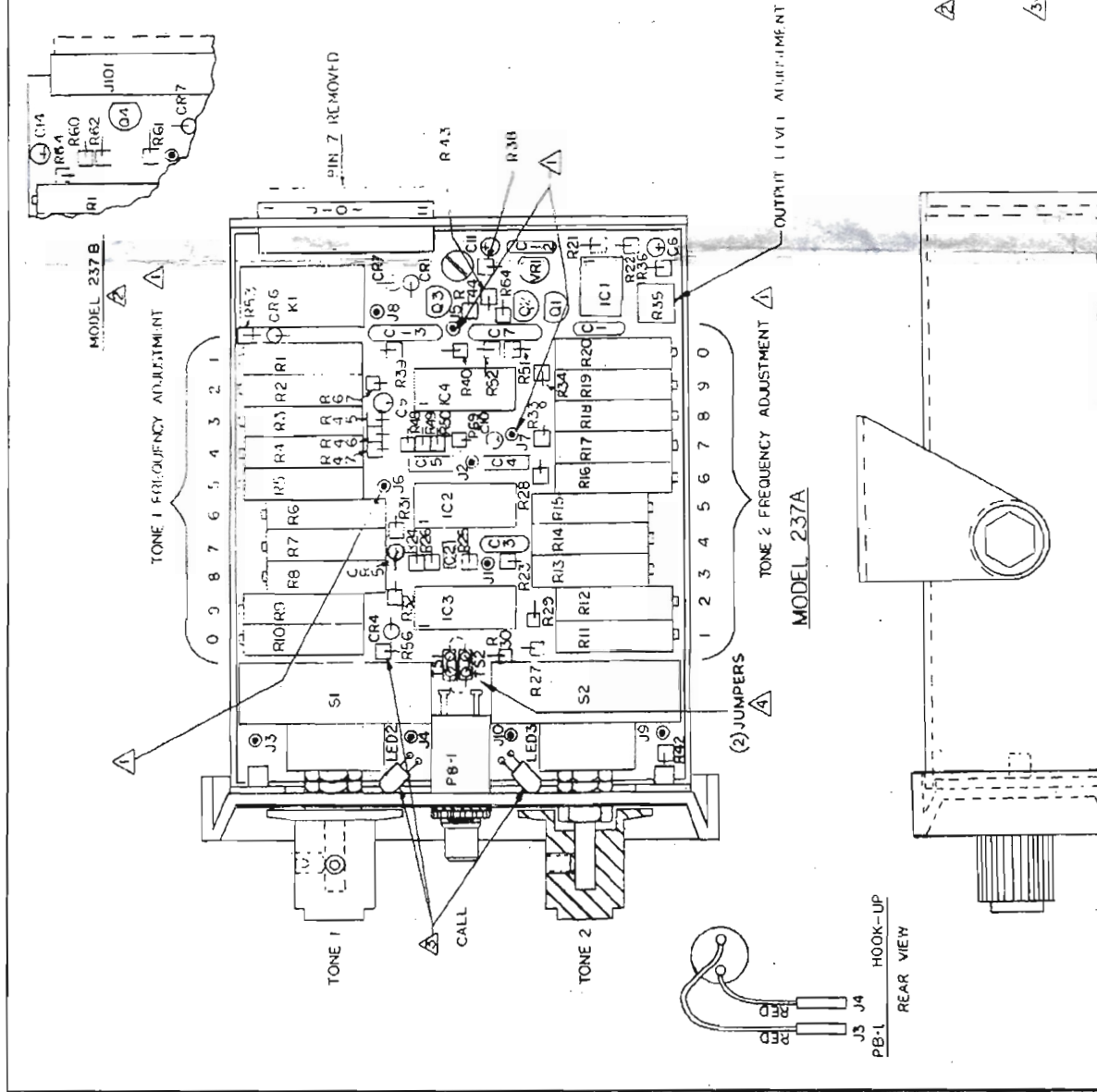

SSC SOLID-STATE COMMUNICATIONS, INC.

REVISED 7-13-79 BY
 L. ELLIS/AL/24-24
 1-000-001-1332
 2-000-001-1332
 3-000-001-1332
 4-000-001-1332
 5-000-001-1332
 6-000-001-1332
 7-000-001-1332
 8-000-001-1332
 9-000-001-1332
 10-000-001-1332
 11-000-001-1332
 12-000-001-1332
 13-000-001-1332
 14-000-001-1332
 15-000-001-1332
 16-000-001-1332
 17-000-001-1332
 18-000-001-1332
 19-000-001-1332
 20-000-001-1332
 21-000-001-1332
 22-000-001-1332
 23-000-001-1332
 24-000-001-1332
 25-000-001-1332
 26-000-001-1332
 27-000-001-1332
 28-000-001-1332
 29-000-001-1332
 30-000-001-1332
 31-000-001-1332
 32-000-001-1332
 33-000-001-1332
 34-000-001-1332
 35-000-001-1332
 36-000-001-1332
 37-000-001-1332
 38-000-001-1332
 39-000-001-1332
 40-000-001-1332
 41-000-001-1332
 42-000-001-1332
 43-000-001-1332
 44-000-001-1332
 45-000-001-1332
 46-000-001-1332
 47-000-001-1332
 48-000-001-1332
 49-000-001-1332
 50-000-001-1332
 51-000-001-1332
 52-000-001-1332
 53-000-001-1332
 54-000-001-1332
 55-000-001-1332
 56-000-001-1332
 57-000-001-1332
 58-000-001-1332
 59-000-001-1332
 60-000-001-1332
 61-000-001-1332
 62-000-001-1332
 63-000-001-1332
 64-000-001-1332
 65-000-001-1332
 66-000-001-1332
 67-000-001-1332
 68-000-001-1332
 69-000-001-1332
 70-000-001-1332
 71-000-001-1332
 72-000-001-1332
 73-000-001-1332
 74-000-001-1332
 75-000-001-1332
 76-000-001-1332
 77-000-001-1332
 78-000-001-1332
 79-000-001-1332
 80-000-001-1332
 81-000-001-1332
 82-000-001-1332
 83-000-001-1332
 84-000-001-1332
 85-000-001-1332
 86-000-001-1332
 87-000-001-1332
 88-000-001-1332
 89-000-001-1332
 90-000-001-1332
 91-000-001-1332
 92-000-001-1332
 93-000-001-1332
 94-000-001-1332
 95-000-001-1332
 96-000-001-1332
 97-000-001-1332
 98-000-001-1332
 99-000-001-1332
 100-000-001-1332

NOTES:
 Δ FREQUENCY ADJUSTMENT: CONNECT TEST JUMPER BETWEEN J5 & J6 FOR TONE 1, J5 & J7 FOR TONE 2. (SEE TEXT)
 Δ FOR MODEL 237B, K1, R53 AND CR6 ARE REPLACED BY R60, R61, R62, C14, Q4, R63.
 Δ DIAL LIGHTS ADDITION ETC.
 Δ SOLID LINE JUMPERS FOR STANDARD PROGRAM.
 Δ DOTTED LINE JUMPERS TO REVERSE S1 & S2 SELECTOR.

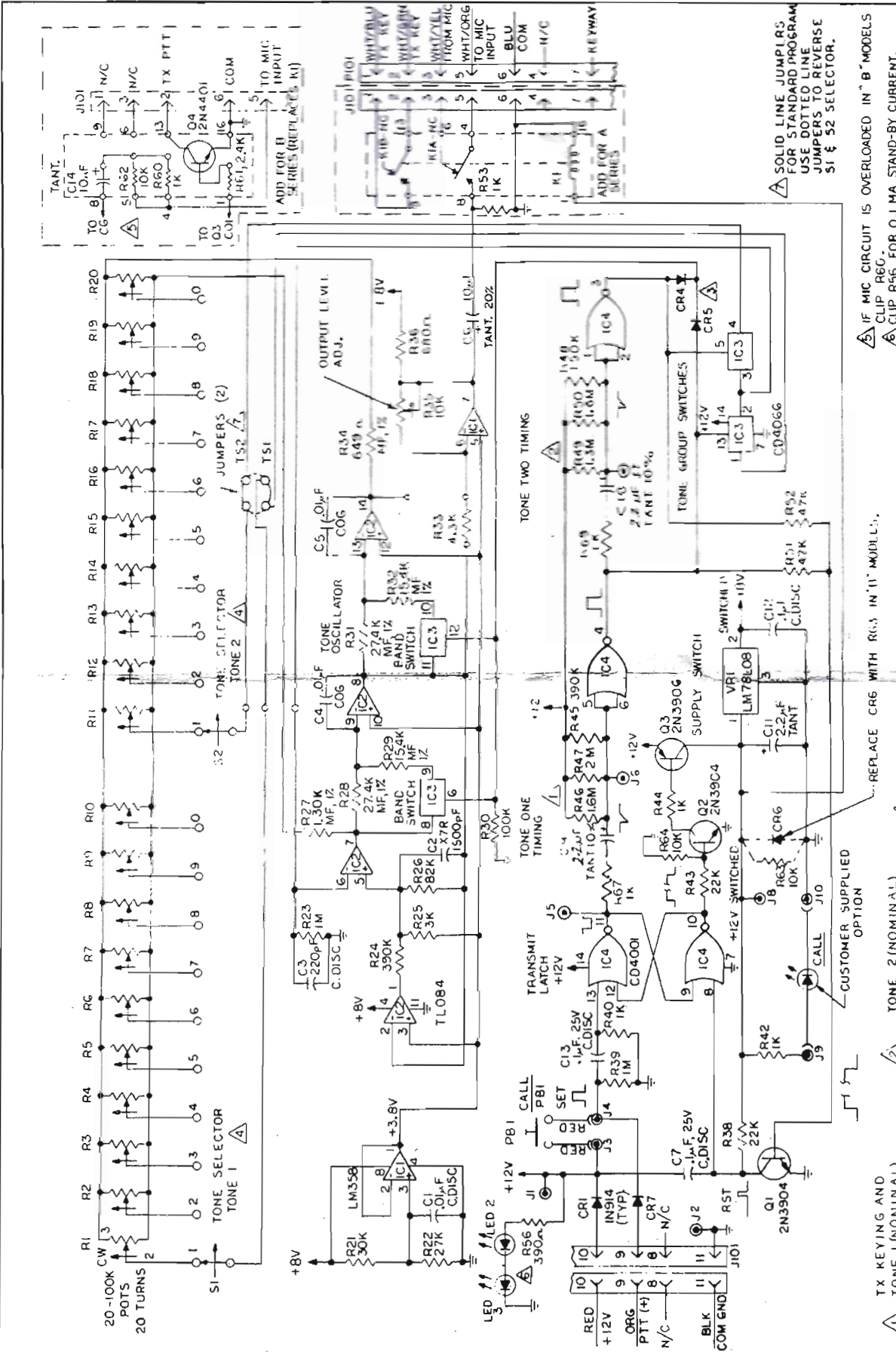

TX KEYING AND TONE 1 (NOMINAL)

R45	R46	R47	TIME
IN	IN	IN	300mS
IN	IN	OUT	330mS
IN	OUT	IN	340mS
IN	OUT	OUT	390mS
OUT	IN	IN	1.3-SEC.
OUT	IN	OUT	2.5-SEC.
OUT	OUT	IN	3.0-SEC.

TONE 2 (NOMINAL)

R48	R49	R50	TIME
IN	IN	IN	120mS
IN	IN	C.T	130mS
IN	OUT	IN	135mS
IN	OUT	OUT	150mS
OUT	IN	IN	1.1-SEC.
OUT	IN	OUT	1.9-SEC.
OUT	OUT	IN	2.5-SEC.

REPLACE CR6 WITH RG3 IN "A" MODEL.
 FIREB BAND SEL.
 HI = 800 HZ - 3500 HZ
 LO = 300 HZ - 1600 HZ

IF MIC CIRCUIT IS OVERLOADED IN "B" MODELS
 CLIP R6G.
 CUP R56 FOR 0.1 MA STAND-BY CURRENT.

REPLACE CR6 WITH RG3 IN "A" MODEL.
 FIREB BAND SEL.
 HI = 800 HZ - 3500 HZ
 LO = 300 HZ - 1600 HZ

REPLACE CR6 WITH RG3 IN "A" MODEL.
 FIREB BAND SEL.
 HI = 800 HZ - 3500 HZ
 LO = 300 HZ - 1600 HZ

REPLACE CR6 WITH RG3 IN "A" MODEL.
 FIREB BAND SEL.
 HI = 800 HZ - 3500 HZ
 LO = 300 HZ - 1600 HZ

REPLACE CR6 WITH RG3 IN "A" MODEL.
 FIREB BAND SEL.
 HI = 800 HZ - 3500 HZ
 LO = 300 HZ - 1600 HZ

REPLACE CR6 WITH RG3 IN "A" MODEL.
 FIREB BAND SEL.
 HI = 800 HZ - 3500 HZ
 LO = 300 HZ - 1600 HZ

REPLACE CR6 WITH RG3 IN "A" MODEL.
 FIREB BAND SEL.
 HI = 800 HZ - 3500 HZ
 LO = 300 HZ - 1600 HZ

SOLID LINE JUMPLERS FOR STANDARD PROGRAM USE DOTTED LINE JUMPLERS TO REVERSE S1 & S2 SELECTOR.

SSC SOLID-STATE COMMUNICATIONS, INC.
 MODEL 237 SERIES ENCODERS SCHEM.
 S-C2-0868-8

IV. CODE PROGRAMMING

NOTE: If option 2 (Factory Programming) has been ordered, check for label or list of frequencies with timing format and proceed to Section V, "Output Level Adjustment." If the encoder has not been previously programmed, the timing will be 300ms first tone including initiate delay and 120ms second tone. Both groups of tones will be set for operation in the 800Hz to 3500Hz frequency band. Continue with the following field code programming procedure prior to installation in the vehicle.

In the event this is part of a new system using both the 237 Encoder and the 224 Decoder, it is suggested that a frequency table of 20 discrete tones be made by starting with 850Hz and multiplying that and each succeeding frequency by 1.07. Use the first 10 for Tone One and the second 10 for Tone Two. Extend the second tone length for alert tone use.

Selector Switch: Normally, the first tone is selected by switch S-1 on the left hand side and the second tone by S-2 on the right hand side. In some Reach and certain other coding plans, the reverse of the above is true. In this event, see Note 7 on the schematic and Note 4 on the assembly drawing for details on reversing the rotary switch tone control.

Timing Format: Determine the required lengths of the first and second tone groups. Refer to tables 1 and 2 found on the attached schematic. Clip out or retain appropriate timing resistors according to requirements. The first tone length incorporates an additional time increment to allow the transmission path to be completed before the first tone is received at the decoder site.

Frequency Bands: The first and second tone groups may operate independently in either the low band of 300Hz to 1600Hz or in the high band of 800Hz to 3500Hz. Determine the required bands of operation and refer to table 3 found on the schematic. Clip or retain appropriate diodes as required.

Frequency Adjustments: Determine the exact frequencies to be used in the code format from tables supplied by the manufacturer of the associated decoders. Refer to note 4 on the schematic for the application of jumpers required to hold each of the tone groups in sustained oscillation. Press the "CALL" button to initiate each tone group. Set the associated tone selector switch for each tone to be adjusted. Adjust R35 (output level) as required to drive a frequency counter. Adjust appropriate 20 turn pots for required frequencies. Remove jumper following frequency adjustments.

Bench Testing: It is a prudent idea to test the encoder for correct operation prior to installation in a vehicle.

V. OUTPUT LEVEL ADJUSTMENT

Note: This procedure must be done with all encoders whether or not they have been factory programmed.

Installation: The encoder should be installed or connected to the associated radio or transmitting device per interface wiring information found on the schematic and interface drawing.

Test Keying: To maintain a constant tone output and transmitter keying for adjustment purposes, connect a jumper between J5 and J6, then press the Call button.

Level Adjustment: With the unit keyed and transmitter on, use a station monitor to observe deviation and adjust R35 for between ± 4 KHz to ± 5 KHz deviation. Remove the test jumper to end test transmission. Install cover and make final mechanical installation.

VI. FINAL TEST

Using full transmission path, test call a few decoders. In the event tone respond, add additional first tone time per table 1 on the schematic.

VII. WARRANTY

Standard 237 series encoders are warranted for 3 years on parts and 2 years on labor providing all work is done by the SSC factory. Damage to P.C. Board traces or as a result of external forces will void this warranty. Equipment to be repaired must be shipped to the SSC factory freight prepaid with a note indicating the nature of the problem. Units will be returned pre-paid. Out of warranty repairs require customer written authorization and will be billed at the then current labor rate and parts cost if not covered.