



SOLID STATE COMMUNICATIONS, INC.
21060 Corsair Blvd. Hayward California 94545
Telephone: (415) 785-4610 Fax: (415) 785-7527

MODEL 836/838AA

OPERATING SPECIFICATIONS

MODEL 836AA/838AA
4 FUN./10 FUN. + PTT, MON. LINE TER-
MINATION BASE STATION ADAPT.
REV 3: JUNE 27, 1991

GENERAL

The SSC Model 836AA and Model 838AA tone remote adapters are designed to provide remote control of a radio base station via a dedicated 2 or 4-wire telephone line or other voice grade circuit.

The 836AA furnishes tone controlled relays for Push-To-Talk, Monitor and 4 functions (e.g., channel selection). The 838AA is a 10 function tone version, composed of an 836AA and an optional plug-on 837AA (providing the 6 additional relays and support logic). The 837AA option board includes a 50 pin Telco connector (as well as the standard solder/wire wrap terminals). The function relays on the 836AA and the 838AA can be configured by the user into a wide variety of interlocked groups of latched and/or independent momentary relays.

For adaptability, the 836AA function relays F3 and F4 can be controlled by 1350 Hz and/or 1750 Hz and 1250 Hz and/or 1650 Hz respectively.

A notch filter is used to prevent the 2175 Hz keying tone from being transmitted by the base station. When the 836AA/838AA is idle (and configured for simplex operation), the notch filter is switched into the receive audio path to prevent 2175 Hz interference from other stations.

OPERATING SPECIFICATIONS

ELECTRICAL

DC Supply Voltage: 11 Vdc to 17 Vdc (filtered)

DC Supply Current: 92 mA nom., 210 mA nom. maximum (836); 94 mA nom., 260 mA nom. maximum (838)

TRANSMIT AUDIO PATH

Input Impedance (1kHz): 600 ohms balanced

Gain (1kHz into 600 ohms): Adjustable to +12.5 dB

Audio Output Level (1kHz): 1.1 Vrms max., into 600 ohms
1.5 Vrms max., into 100K ohms

Frequency Response: 300 Hz to 3300 Hz

Distortion (1kHz): less than 1%

Notch Filter: 40 dB notch, tunable between 800 Hz and 3300 Hz

RECEIVE AUDIO PATH

Output Impedance (1kHz): 600 ohms balanced

Gain (1kHz into 600 ohms): Adjustable to +14.5 dB

Audio Output Level (1kHz): +4.5 dBm maximum unclipped into 600 ohms

Frequency Response: 300 Hz to 3300 Hz within 3 dB

Distortion (1kHz): less than 1%

TONE DECODER

Tone Input Level Range: from -45 dBm to +10 dBm

Control Tone Frequencies (836):

Guard Tone: 2175 Hz

PTT: 2175 Hz

Monitor: 2050 Hz

F1: 1950 Hz

F2: 1850 Hz

F3: 1750 Hz and/or 1350 Hz (*)

F4: 1650 Hz and/or 1250 Hz (*)

Control Tone Frequencies (838): As Above, plus the following:

K1: 1550 Hz

K2: 1450 Hz

K3: 1350 Hz or 1750 Hz (*)

K4: 1250 Hz or 1650 Hz (*)

K5: 1150 Hz

K6: 1050 Hz

* DIP Switch Selectable.

PTT Detection Time: 250 ms nominal from start of tone sequence

Control Outputs: PTT and Monitor: 2 form "C" contacts

F1 - F4: 1 form "A" contacts

K1 - K6: 1 form "A" contacts

Operating Temperature Range: -40 C to +85C

MECHANICAL

836AA: 56 pin edge connector card (5.58 " H x 5.96 " W x 1.00 " D)

838AA: 56 pin edge connector card (5.58 " H x 5.96 " W x 1.80 " D, with 837AA break tabs removed).

Both versions can be mounted in a TELLABS type 10 (or equivalent) card rack (although the 838AA will use two slots); a TELLABS type 1911 single card enclosure (available through SSC); or mounted on standoffs and 2/56 screws.

INSTALLATION:

CONFIGURATION LOGIC

Note: power should not be applied to the 836AA/838AA until the configuration logic section has been completed.

UPGRADING FROM 836AA TO 838AA: By combining an 836AA with an optional 837AA, the tone decoder capacity is increased from four to ten independently controllable function relays (excluding Monitor). The installation procedure is as follows:

1. Remove power from the 836AA.
2. Remove diode D2 from the 836AA (see component locator).
3. Remove the 836AA from its present edge connector and insert it into the edge connector socket of the 837AA.
4. All external connections must now be made on the 837AA's wire-wrap/solder pins or (with the exception of power and ground) through the 837AA's 50-pin Telco connector.

SIMPLEX OPERATION: The 836AA/838AA is factory set for simplex operation. If the 836AA/838AA is to be changed from duplex back to simplex operation:

1. Remove power.
2. Insert diode D4 as per the component locator.
3. Place jumper JP1 in position "A".
4. Remove jumper JP2.
5. If no other configuration changes are to be made, restore power.

DUPLEX OPERATION:

1. Remove power.
2. Remove diode D4.
3. Place jumper JP1 in position "B".
4. Insert jumper JP2.
5. If no other configuration changes are to be made, restore power.

DIP SWITCH PROGRAMMABLE OPTIONS: User programmable options (e.g. monitor response, relay configurations) are determined by DIP switch settings as per Tables 1, 2, 3 (and 4 for the 838AA) on pages 4 and 5. The program used in the 836AA/838AA will only read the board configuration information during its initial power-up routine. Hence, all DIP switches must be set for the desired configurations before power is applied to the board. In order to change these configurations:

1. Power must be removed.
2. DIP switches are reset.
3. Power is restored to the board.

F3 and F4 RESPONSE FREQUENCIES: For the sake of compatibility with various tone remote control units, the control tones to which the F3 and F4 relay's will respond can be selected via DIP switches 1 and 2 on the 836AA as per Table 1, page 4.

MONITOR RESPONSE OPTIONS: The monitor relay will react to a 2050 Hz control tone and Push-To-Talk as per Table 2, page 4. Set DIP switches 3 and 4 on the 836AA for the desired monitor response.

836AA/838AA FUNCTION TONE RELAY CONFIGURATION: Function relay response is selected via the 836AA's DIP switches 5, 6 and 7 as set per Table 3 (and possibly Table 4 if an optional 837AA board is attached to the 836AA) on pages 4 and 5.

Note that on Table 3, options "R" and "S" are equivalent to option "M" if an 837AA option board has not been installed. (Again, an 838AA is composed of an 836AA and an optional 837AA.)

If you are configuring an 838AA, options "R" and "S" will override all relay configurations on Table 4 (set via 837AA DIP switches). Options "M" through "Q" will only affect the relays on the 836AA, ie, relays F1, F2, F3 and F4. Similarly, the relay configuration chosen for the 837AA (via 837AA DIP switches per Table 4) will only affect relays K1 through K6 on the 837AA.

Note: There is no configuration "32" on Table 4, this has been reserved for future use. If all the DIP Switches on the 837AA are placed "open", relays K1 thru K6 will be inoperative.

As an example for interpreting Tables 3 and 4, assume option "Q" of Table 3 is chosen. The table is indicating that relays F1 and F2 are interlocked. This means when F1 is set (via a 1950 Hz function tone), F2 will be reset automatically. The reverse will happen upon the next 1850 Hz function tone. For either 1950 Hz or 1850 Hz function tones, relays F3 and F4 will be unaffected. Relay F3 or F4 will be independently set momentarily (for approximately 80 ms) upon detection of their respective function tones. The state of F3 or F4 will have no effect on F1 or F2, or on one another.

Now if an 837AA option board is attached to the 836AA, let's assume option "17" from Table 4 has been chosen. Relay K1 on the 837AA will be interlocked with relay K2, relays K3 and K4 will be interlocked, and relays K5 and K6 will be momentarily set upon the detection of their respective function tones (1150 Hz and 1050 Hz).

Note: Upon completion of the Configuration Logic Section, power can be restored to the 836AA/838AA. Take special notice of the LED's as power is being restored. The LED's and their respective relays will be momentarily set in a sequential order if the microcontroller has been successfully reset. This will happen quickly so watch carefully. Repeat power-up if this is not observed. Upon completion of the microcontroller's "power-up" routine, relay F1 will initially be set (latched) regardless of the selected configuration, all other relays will be off.

It is a good idea to bench test the 836AA/838AA with the associated Tone Remote Controls before installing the units in the field. Operation of the Tone Remote Adapter relays can be checked visually using the LED's mounted on the P.C. Board. Refer to the schematic and component locator drawings in this instruction manual for the locations of the input-output terminals, adjustments and indicator LED's.

It is assumed that the associated Tone Remote Controls have been adjusted according to the published specifications before this procedure is performed. The 2175 Hz burst tone should be set for 130 ms. at +10dBm with voice limited to 0dBm peak. Function tones should be 45 to 50 ms long at a relative 0dB with the PTT holding tone at a relative -20dB. The SSC factory presents the 836AA/838AA Tone Remote Adapter to operate with the above signals from corresponding Tone Remote Controls. In so much as each base radio station interfaces at different RX and TX audio levels, these levels and the 2175 Hz sensitivity will have to be adjusted when the adapter is installed at the final location with the losses of the interconnecting phone line or other medium in the path.

ADJUSTMENTS AND EXTERNAL CONNECTIONS

GENERAL: All connections to an 836AA must be made through the wire-wrap/solder pin on the provided edge connector socket. The connections to an 838AA may be either through the wire-wrap/solder pins or via the 50-pin Telco connector on the optional 837AA. Note however, that power and ground have no provisions on the 50-pin Telco connector, they must be made on the edge connector pins.

Connect the +DC power (11 VDC to 17 VDC, filtered) to edge connector pins 55 or 56. Connect the radio receiver's (RX) audio output to edge connector pin 38 (or Telco connector pin 44). Connect the transmitter's (TX) audio input to edge connector pin 41 (Telco connector pin 34). Connect chassis ground, RX audio common, and TX audio common to edge connector pins 1 or 2. For simplex operation, connect the bi-directional audio pair to edge connector pins 51 and 52 (or Telco connector pins 49 and 24). For duplex operation, connect the receive audio pair to edge connector pins 51 and 52 (Telco pins 49 and 24), and connect the transmit audio pair to edge connector pins 53 and 54 (Telco pins 50 and 25).

RECEIVE AUDIO PATH ADJUSTMENTS: Turn R7 completely counter-clockwise. Disable the radio receiver tone and noise squelch to produce white noise. Adjust the radio receiver audio output for approximately 0.8 Vrms across the 836AA/838AA RX audio input edge connector pins 38 and 1 (common), (or across Telco connector pin 44 and edge connector 1). Adjust R4 for a level of 0.4 Vrms at TP-4 with reference ground at TP-11. Adjust R1 for the desired level (-10 dBm nominal, 0.25 Vrms) across the interconnecting telephone line (edge connector pins 51 and 52, Telco pins 49 and 24, or TP-1 and TP-2).

TONE DECODER ADJUSTMENTS: Perform the following procedure before connecting the PTT control relay to the transmitter. With a steady 2175 Hz Guard tone set at +10dBm at the remote control end, adjust R7 for 1.8 Vrms across TP-6 and ground (TP-11).

TRANSMIT AUDIO PATH ADJUSTMENTS: Set up to test transmitter output deviation with a dummy load and a station modulation monitor. Have someone at the tone remote control press to talk and sound a constant "OOOOOOO" into the microphone of the handset. Adjust R6 for full undistorted modulation of the transmitter as measured on the modulation monitor.

After completing the above steps, connections may be made between the 836AA/838AA control relays and the radio base station (see schematics for actual pin-outs). Connect an antenna to the base station and make a test radio contact with a field or other unit using the remote control. Check all operating functions and quality of speech. Over drive into the phone line or transmitter may cause distortion.

MAINTENANCE AND TROUBLESHOOTING

The 836AA/838AA has sufficient gain to compensate for up to 20 dB of line loss. However, loss of more than 6 dB without gain adjustments will result in a degradation of reliability and voice signal quality. A periodic check of line loss and 2175 Hz sensitivity in accordance with the previous section would be a good idea. Make appropriate adjustments as required.

If leakage of the 2175 Hz PTT holding tone is heard over the air, re-adjust the notch filter for a better null using both R5 and R2.

FIELD ADJUSTMENTS OF FACTORY SETTINGS

(To be performed only after changing parts in filter or PLL circuits.)

BANDPASS FILTERS: With a steady 2175 Hz guard tone present (from the tone remote control unit) and R7 set for 1.8 Vrms at TP-6, adjust R10 for maximum amplitude across TP-9 and ground (TP-11). Adjust R9 for maximum amplitude across TP-10 and ground (TP-11).

PHASE-LOCK-LOOP VCO CENTER FREQUENCY: The free-running frequency of the 836AA/838AA PLL is factory set at 1500 Hz. Deviations over time and temperature of up to +/- 25 Hz are acceptable. Before measuring the PLL center frequency, turn R7 completely counter-clockwise. Connect a frequency counter across TP-12 and ground (TP-11). Adjust R3 as necessary. If possible, this adjustment should be made while the unit is operating in typical or "average" temperature conditions at it's location. Reset TP-6 for 1.8Vrms via R7 with a steady 2175 Hz guard tone present from the tone remote control unit.

836 / 838 SWITCH SELECTABLE OPTIONS

Table 1 F3/F4 Control Frequencies

836 SW1-1	836 SW1-2	F3 FREQ.	F4 FREQ.
CLOSED	CLOSED	1350Hz	1250Hz
CLOSED	OPEN	1750Hz	1650Hz
OPEN	CLOSED	1350Hz or 1750Hz	1250Hz or 1650Hz
OPEN	OPEN	DISABLED	DISABLED

Table 2 Selectable Monitor Options

836 SW1-3	836 SW1-4	MONITOR OPTION	MON. SW. RESPONSE	PTT RESPONSE	
				PTT START	PTT END
CLOSED	CLOSED	A	TIMED*	SET	RESET
CLOSED	OPEN	B	LATCHED	SET	RESET
OPEN	CLOSED	C	TIMED*	SET	REFRESH TIMER
OPEN	OPEN	D	LATCHED		RESET

*Timer sets Monitor Relay for approx. 30 seconds.

Table 3 Selectable Relay Configurations

CONFIGURATION		M	N	O	P	Q	R	S	T
836 SWITCH	SW1-5	CL	OP	CL	OP	CL	OP	CL	OP
	SW1-6	CL	CL	OP	OP	CL	CL	OP	OP
	FREQ. RLY. SW1-7	CL	CL	CL	CL	OP	OP	OP	OP
1950	F1			ON*	M				C
1850	F2				M				U
1750/1350	F3				M	M			S
1650/1250	F4				M	M			T
1550	K1								O
1450	K2								M
1350/1750	K3								
1250/1650	K4								
1150	K5								
1050	K6								

↑

DETERMINED BY
DIP SWITCHES ON
837 OPT. BOARD

↓

SEE TABLE 4

- = Group of interlocking latched relays.
- = Group of interlocking latched relays.
- M = Momentary (80 ms duration)
- CL = Switched closed.
- OP = Switch open.
- * = Note: 1950Hz will reset F2-F4.

Table 4 837 Option Board Relay Configuration

CONFIGURATION NO.		1	2	3	4	5	6	7	8	9	10	11	12	13	14	15	16	17	18	19	20	21	22	23	24	25	26	27	28	29	30	31
837 SWITCH	SW1-1	CL	CL	CL	CL	CL	CL	CL	CL	CL	CL	CL	CL	CL	CL	CL	OP	OP	OP	OP	OP	OP	OP	OP	OP	OP	OP	OP	OP	OP	OP	OP
	SW1-2	CL	CL	CL	CL	CL	CL	CL	CL	OP	OP	OP	OP	OP	OP	OP	CL	CL	CL	CL	CL	CL	CL	CL	CL	OP	OP	OP	OP	OP	OP	OP
	SW1-3	CL	CL	CL	CL	OP	OP	OP	OP	CL	CL	CL	CL	OP	OP	OP	OP	CL	CL	CL	CL	OP	OP	OP	OP	CL	CL	CL	CL	OP	OP	OP
	SW1-4	CL	CL	OP	OP	CL	CL	OP	OP	CL	CL	OP	OP	CL	CL	OP	OP	CL	CL	OP	OP	CL	CL	OP	OP	CL	CL	OP	OP	CL	CL	OP
	FREQ. RLY SW1-5	CL	OP	CL	OP	CL	OP	CL	OP	CL	OP	CL	OP	CL	OP	CL	OP	CL	OP	CL	OP	CL	OP	CL	OP	CL	OP	CL	OP	CL	OP	CL
1550	K1	0	█	█	█	█	█	█	█	█	█	█	█	M	█	█	M	█	█	M	█	█	M	M	█	M	█	M	M	M	█	█
1450	K2	0	█	█	█	█	█	█	█	█	█	█	M	█	█	M	█	█	M	█	█	█	█	█	█	M	█	M	M	M	█	█
1350/1750	K3	0	█	█	█	█	█	█	█	█	█	M	█	█	M	█	█	M	█	█	█	█	█	█	M	M	█	M	M	█	█	
1250/1650	K4	0	█	█	█	█	█	█	█	█	M	█	█	M	█	█	M	█	█	M	█	█	█	█	M	█	M	█	M	M	█	█
1150	K5	0	█	█	█	█	█	█	█	M	█	█	█	M	█	█	M	█	█	█	█	█	█	█	M	█	M	M	█	M	█	█
1050	K6	0	█	█	█	█	█	█	M	█	█	█	█	M	█	█	M	█	█	█	█	█	█	█	M	█	M	M	█	M	M	M

- █ = Group of interlocking latched relays.
- ▒ = Group of interlocking latched relays.
- ░ = Group of interlocking latched relays
- M = Momentary (80 ms duration).
- CL = Switch closed.
- OP = Switch open.
- 0 = Off

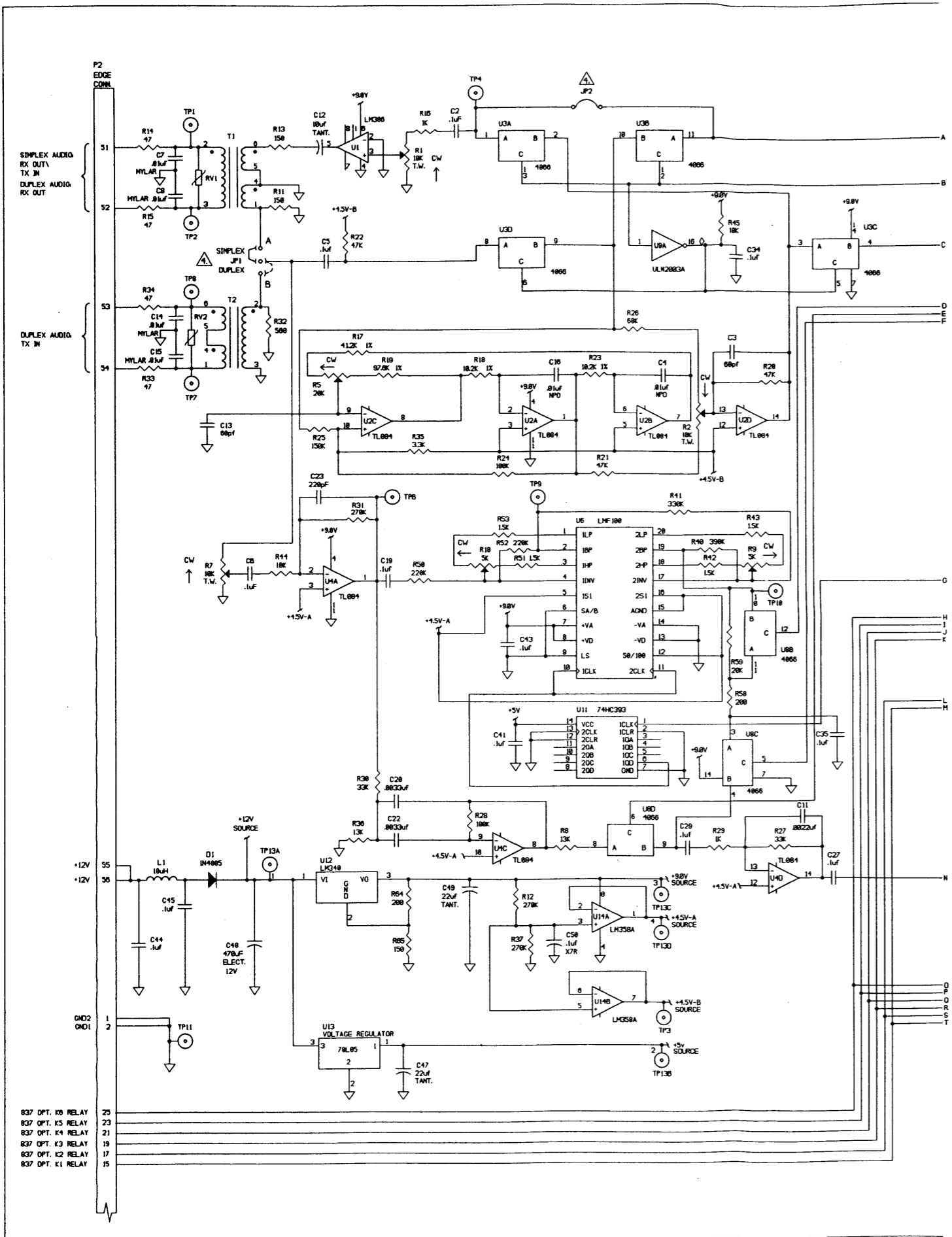

- 837 OPT. K8 RELAY
- 837 OPT. K5 RELAY
- 837 OPT. K4 RELAY
- 837 OPT. K3 RELAY
- 837 OPT. K2 RELAY
- 837 OPT. K1 RELAY

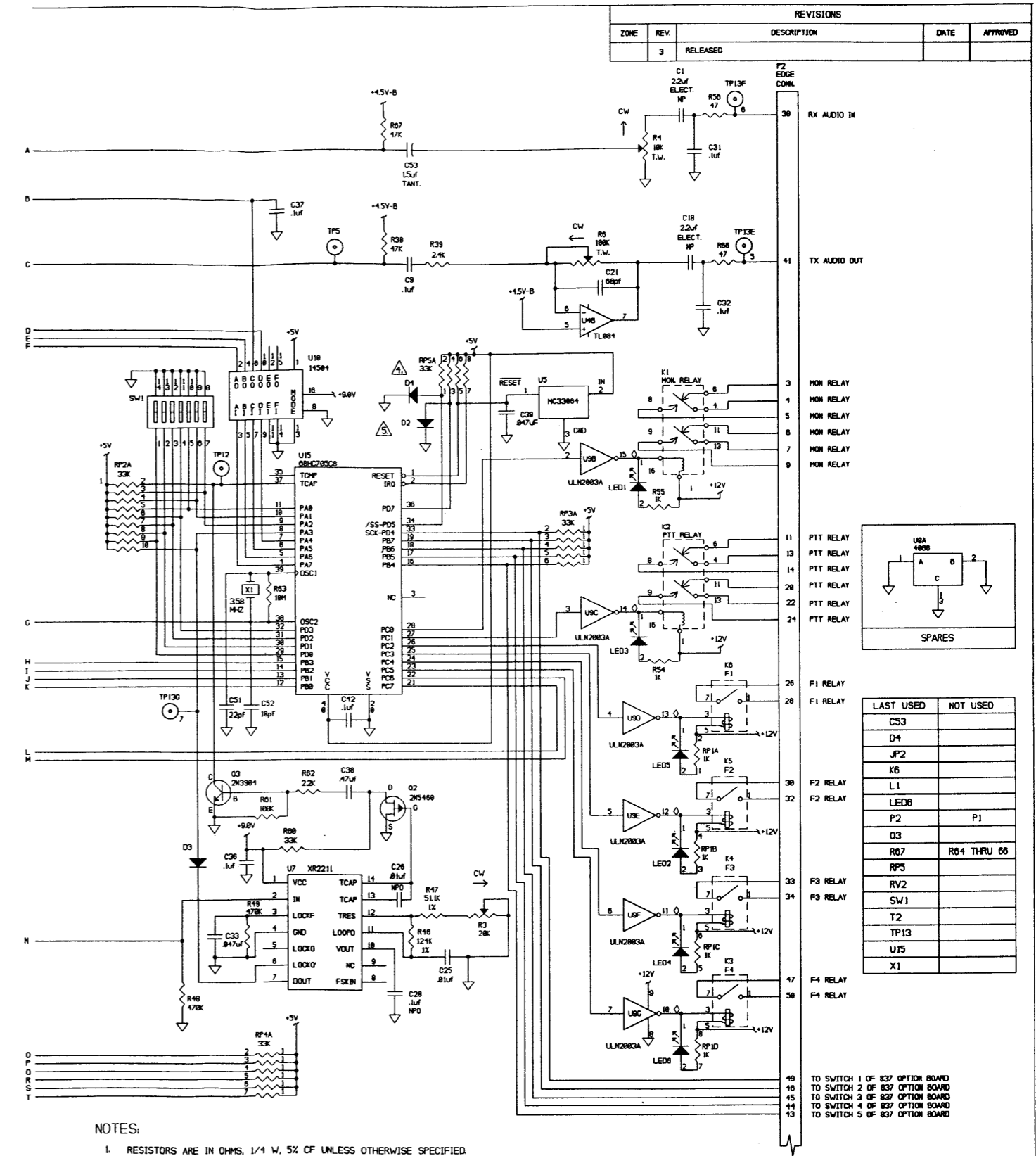

- NOTES:
- RESISTORS ARE IN OHMS, 1/4 W, 5% CF UNLESS OTHERWISE SPECIFIED.
 - ◀ SYMBOL INDICATES OPEN COLLECTOR OUTPUT (U9A-G).
 - ALL CAPACITORS ARE MONOLITHIC CERAMIC (50V) TYPES UNLESS OTHERWISE NOTED.
- ▲ FOR DUPLEX (4-WIRE) OPERATION:
 (A) REMOVE DIODE D4.
 (B) PLACE JUMPER JF1 IN POSITION 'B'.
 (C) INSERT A JUMPER AT JF2.
- ▲ REMOVE DIODE D2 IF THE OPTIONAL 837AA RELAY PCB IS TO BE USED IN CONJUNCTION WITH THE 836.

UNLESS OTHERWISE SPECIFIED DIMENSIONS ARE IN INCHES TOLERANCES ARE: FRACTIONS DECIMALS ANGELS .XX .XXX	CONTRACT NO.	APPROVALS	DATE	SSC SOLID-STATE COMMUNICATIONS, INC. 21060 CORSAIR BLVD. HAYWARD CA. 94545 U.S.A. (415) 785-4610 TELEX: 33-5364
MATERIAL	DATE	DATE	DATE	
FINISH	CHECKED	ISSUED		TITLE SCHEMATIC DIAGRAM, MODEL 836 PHONE LINE TERMINATION
DO NOT SCALE DRAWING	SCALE NONE			SIZE FSCM NO. DWG. NO. REV. B S-B2-1756 3
				SHEET 1 OF 1

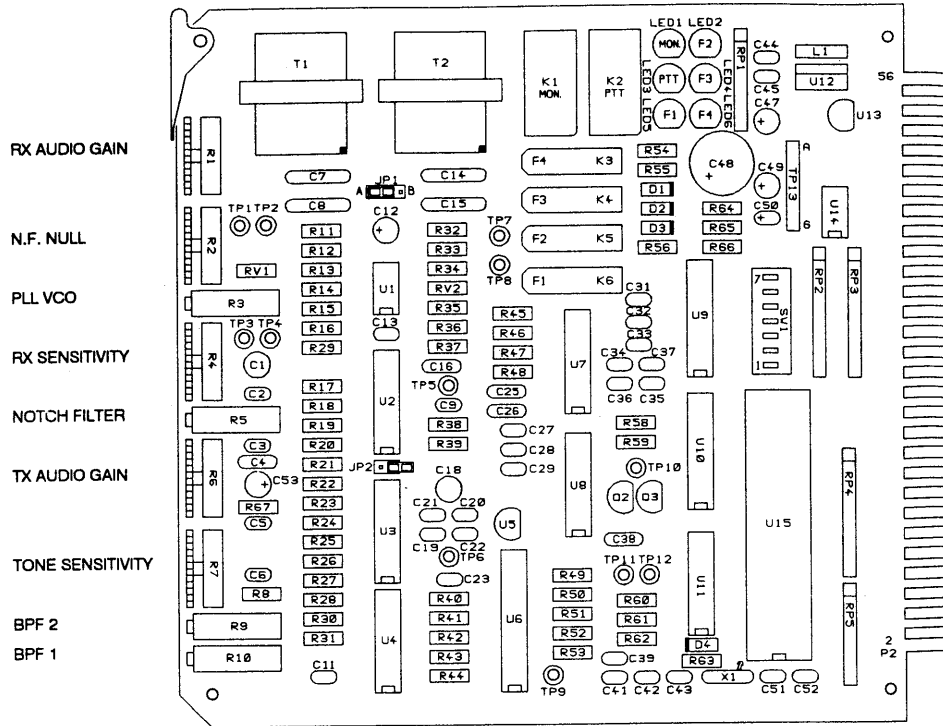

Item	Qty.	Ref. Des.	Description	SSC #
24	1	L1	INDUCTOR, 10 UH	26-00315-001
25	6	LED 1,2,3,4,5,6	LED, T1 YEL. DIFFUSED	64-00591-000
26	1	Q3	TRANSISTOR, 2N3904 N-P-N	22-00236-000
27	1	Q2	TRANSISTOR, 2N5460 J-FET P-CH	22-05460-000
28	6	R14,15,33,34,56,66	RES., 47 OHM CF 1/4W 5%	18-10047-153
29	3	R65,11,13	RES., 150 OHM CF 1/4W 5%	18-10150-153
30	2	R58,64	RES., 200 OHM CF 1/4W 5%	18-10200-153
31				
32	1	R32	RES., 560 OHM CF 1/4W 5%	18-10560-153
33	4	R16,29,54,55	RES., 1K CF 1/4W 5%	18-20010-153
34	4	R42,43,51,53	RES., 1.5K CF 1/4W 5%	18-20015-153
35	1	R62	RES., 2.2K CF 1/4W 5%	18-20022-153
36	1	R39	RES., 2.4K CF 1/4W 5%	18-20024-153
37	1	R35	RES., 3.3K CF 1/4W 5%	18-20033-153
38	3	R39,44,45	RES., 10K CF 1/4W 5%	18-30100-153
39	2	R18,23	RES., 10.2K MF 1/4W 1%	18-30102-340
40	2	R8,36	RES., 13K CF 1/4W 5%	18-30130-153
41	1	R59	RES., 20K CF 1/4W 5%	18-30200-153
42	5	R27,30,57,59,60	RES., 33K CF 1/4W 5%	18-30330-153
43	1	R17	RES., 41.2K MF 1/4W 1%	18-30416-340
44	5	R20,21,22,38,67	RES., 47K CF 1/4W 5%	18-30470-153
45	1	R47	RES., 51.1K MF 1/4W 1%	18-30511-340
46	1	R26	RES., 68K CF 1/4W 5%	18-30680-153
47	1	R19	RES., 97.6K MF 1/4W 1%	18-30976-340
48	3	R24,28,61	RES., 100K CF 1/4W 5%	18-41000-153
49	1	R46	RES., 124K MF 1/4W 1%	18-41240-340
50	1	R25	RES., 150K CF 1/4W 5%	18-41500-153
51	3	R31,12,37	RES., 270K CF 1/4W 5%	18-42700-153
52	1	R41	RES., 330K CF 1/4W 5%	18-43300-153
53	1	R40	RES., 390K CF 1/4W 5%	18-43900-153
54	2	R48,49	RES., 470K CF 1/4W 5%	18-44700-153
55	1	R63	RES., 10 MEG CF 1/4W 5%	18-50100-153
56	2	R9,10	POT., 5K CERMET TRIM 15 TURN	20-20050-334
57	4	R1,2,4,7	POT., 10K CARBON THUMBWHEEL	20-30100-113
58	2	R5,3	POT., 20K CERMET TRIM 20 TURN	20-30200-334
59	1	R6	POT., 100K CARBON THUMBWHEEL	20-41000-113
60	1	RP1	RES., PAK 1K SIP 8	18-20010-882
61	1	RP5	RES., PAK 33K SIP 8	18-30330-882
62	3	RP2,3,4	RES., PAK 33K SIP 10	18-30331-882
63	2	RV1,2	VARIATOR, V39MA2A	16-00583-301
64	1	SW 10	SWITCH, ROCKER 7 POS. DIP	28-00184-000
65	2	T1,2	TRANSFORMER., AUDIO #42TM016	26-00229-003
66	1	TP13	HEADER, 7 PIN	32-00195-000
67	2	TP1-12	PIN, SM BEAD .062X.435	40-00101-000
68	1	U14	TRANSISTOR, IRFD HEX-FET P CHAN	22-00704-000
69	2	U2,4	IC, TL084CN QUAD OP AMP	24-08400-008
70	1	U6	IC, LMF100CCN SW CAP FILTER	24-10000-008
71	1	U13	IC, 78L05 VOLTAGE REGULATOR	24-78050-006
72	1	U9	IC, ULN2003A DARRLINGTON ARRAY	24-20030-009
73	1	U7	IC, XR2211P PHASE LOCK LOOP	24-22110-008
74	1	U5	IC, 33064 LOW VOLTAGE DETECTOR	24-33064-001
75	1	U12	IC, LM340T-5 VOLTAGE REGULATOR	24-34050-008
76	1	U15	IC, LM358N DUAL OP AMP	24-35800-008
77	1	U1	IC, LM386N-1 AUDIO POWER AMP	24-38600-008
78	2	U3,18	IC, 4066 ANALOG SWITCH	24-40660-001
79	1	U10	IC, MC14504BP HEX LEVEL SHIFTR	24-45040-001
80	1	U16	IC, 68HC705C8 CONTROLER	24-68705-011
81	1	U11	IC, SN74HC393N BINARY COUNTER	24-74393-012
82	1	X1	CRYSTAL., 3.579545MHZ HC18	46-00061-000

8

Item	Qty.	Ref. Des.	Description	SSC #
1	1	C52	CAP., 18pF NPO 5% 100V	14-20180-726
2	1	C51	CAP., 22pF NPO 5% 100V	14-20220-726
3	3	C3,13,21	CAP., 68pF DISC 10% 1000V	14-20680-569
4	1	C23	CAP., 220pF X7R 20% 50V	14-22200-675
5	1	C11	CAP., .0022uF X7R 10% 50V	14-40022-665
6	2	C20,22	CAP., .0033uF X7R 10% 50V	14-40033-665
7	4	C7,8,14,15	CAP., .01uF MYLAR 10% 630V	14-40100-169
8	4	C4,16,25,26	CAP., .01uF NPO 5% 50V	14-40100-755
9	2	C33,39	CAP., .047uF X7R 10% 50V	14-40470-665
10	19	C2,52,34-37,41-45, 6,9,19,27-29,50	CAP., .1uF X7R 10% 50V	14-41000-665
11	1	C38	CAP., .47uF X7R 10% 50V	14-44700-665
12	1	C53	CAP., 1.5 TANT 10% 25V	14-60015-063
13	2	C1,C18	CAP., 2.2uF ELECT 20% 50V	14-60022-275
14	1	C12,	CAP., 10uF TANT 10% 25V	14-60100-063
15	2	C47,49	CAP., 22uF TANT 10% 16V	14-60220-062
16	1	C48	CAP., 470uF RADIAL ELECT 25V	14-64700-293
17	1	D1	DIODE, 1N759A ZENER	16-00012-354
18	3	D2-4	DIODE, 1N914/1N4148	16-00013-100
19	1	JP1	HEADER, 3 PIN	32-00195-000
20	1	JP2	HEADER, 2 PIN	32-00195-000
21	2	JP1,2	JUMPER, MINI	32-00056-000
22	2	K1,2	RELAY, DPDT 12V 8 PIN DIP	30-00125-000
23	4	K3,4,5,6	RELAY, SIP 1 FORM A 12V	30-00677-000

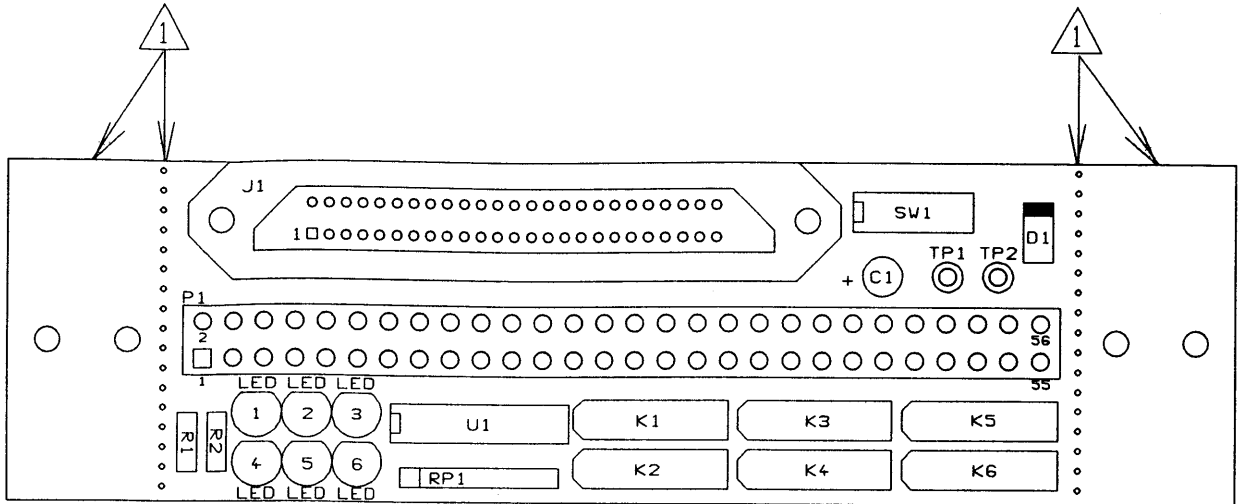

NOTES:

1. SCORE AND BREAK OFF TABS FOR CARD CAGE HOUSING.

Item	Qty.	Ref. Des.	Description	SSC #
1	1		PCB, 837AA	13-01767-000
2	1	U1	IC, ULN2003A	24-20030-009
3	6	LED 1-6	LED, T1 YEL DIFFUSED	64-00591-000
4	1	RP1	RES. PACK, 1K SIP 8	18-20010-882
5	2	R1,2	RES., 1K CF 1/4W 5%	18-20010-153
6	1	SW1	SWITCH, DIP-5	28-00248-000
7	6	K1-6	RELAY, SIP 1 FORM A 12V	30-00677-000
8	1	J1	CONN., 50 PIN TELCO FEM.	32-00138-000
9	1	P1	CONN., EDGE CARD 56 PIN	32-00730-000
10	1	C1	CAP., 10uF TANT 10% 25V	14-60100-063
11	1	TP1,2	PIN, SMALL BEAD .062 X .435	40-00101-000
12	1	D1	DIODE, 1N4005	16-00016-205

REVISIONS				
ZONE	REV.	DESCRIPTION	DATE	APPROVED
	1	RELEASED		

J1 - 50 PIN TELCO CONNECTOR

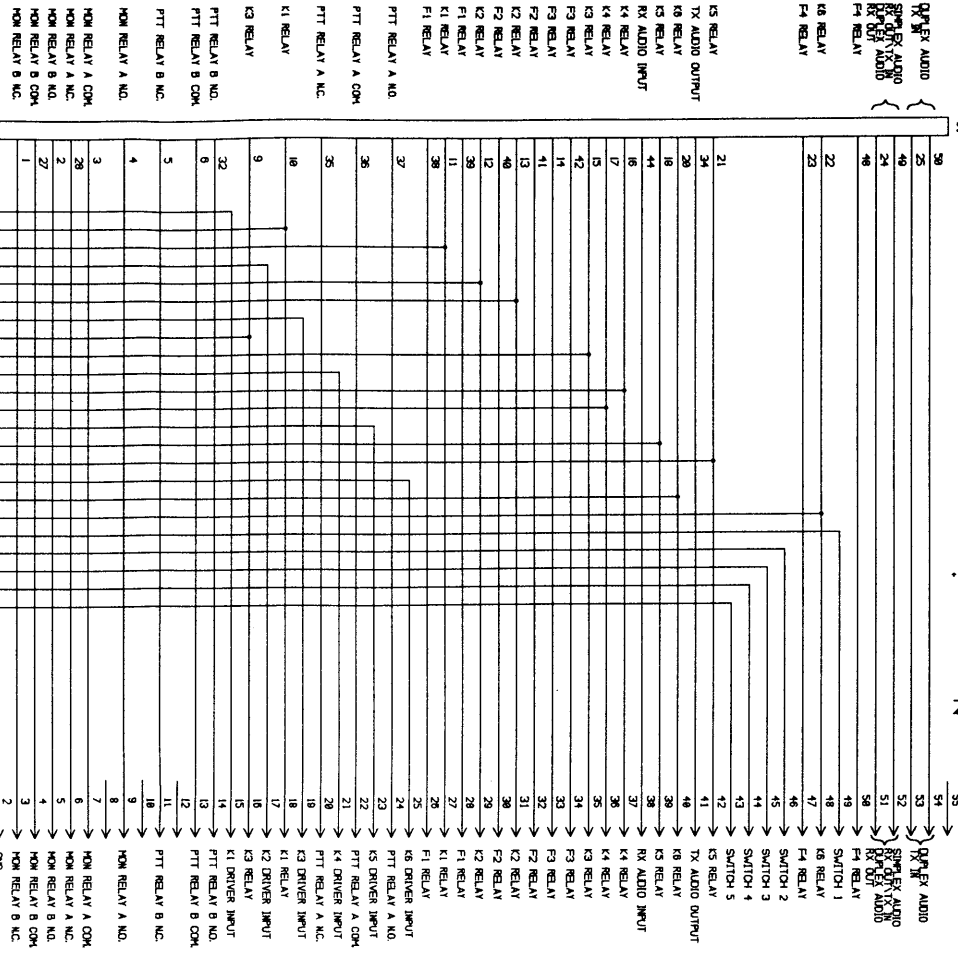

- TX EX AUDIO
- TX AUDIO
- TX AUDIO
- TX AUDIO
- P1 RELAY
- P2 RELAY
- P3 RELAY
- P4 RELAY
- P5 RELAY
- P6 RELAY
- P7 RELAY
- P8 RELAY
- P9 RELAY
- P10 RELAY
- P11 RELAY
- P12 RELAY
- P13 RELAY
- P14 RELAY
- P15 RELAY
- P16 RELAY
- P17 RELAY
- P18 RELAY
- P19 RELAY
- P20 RELAY
- P21 RELAY
- P22 RELAY
- P23 RELAY
- P24 RELAY
- P25 RELAY
- P26 RELAY
- P27 RELAY
- P28 RELAY
- P29 RELAY
- P30 RELAY
- P31 RELAY
- P32 RELAY
- P33 RELAY
- P34 RELAY
- P35 RELAY
- P36 RELAY
- P37 RELAY
- P38 RELAY
- P39 RELAY
- P40 RELAY
- P41 RELAY
- P42 RELAY
- P43 RELAY
- P44 RELAY
- P45 RELAY
- P46 RELAY
- P47 RELAY
- P48 RELAY
- P49 RELAY
- P50 RELAY

P1 - 56 PIN EDGE CONNECTOR

UNLESS OTHERWISE SPECIFIED DIMENSIONS ARE IN INCHES TOLERANCES ARE: FRACTIONS DECIMALS ANGLES X .001		CONTRACT NO.		SOLID-STATE COMMUNICATIONS, INC. 21000 CORSAIR BLVD. HAYWARD CA. 94545 U.S.A. (415) 785-4610 TELEX: 33-5364	
MATERIAL		APPROVALS	DATE	TITLE	
FINISH		DRAWN	RK.	SCHEMATIC, MODEL 837AA	
DO NOT SCALE DRAWING		CHECKED		SIZE	FSCH NO.
		ISSUED		A	
				DWG. NO.	REV.
				S-A2-1762	1
				SCALE	SHEET 1 OF 1
				NONE	

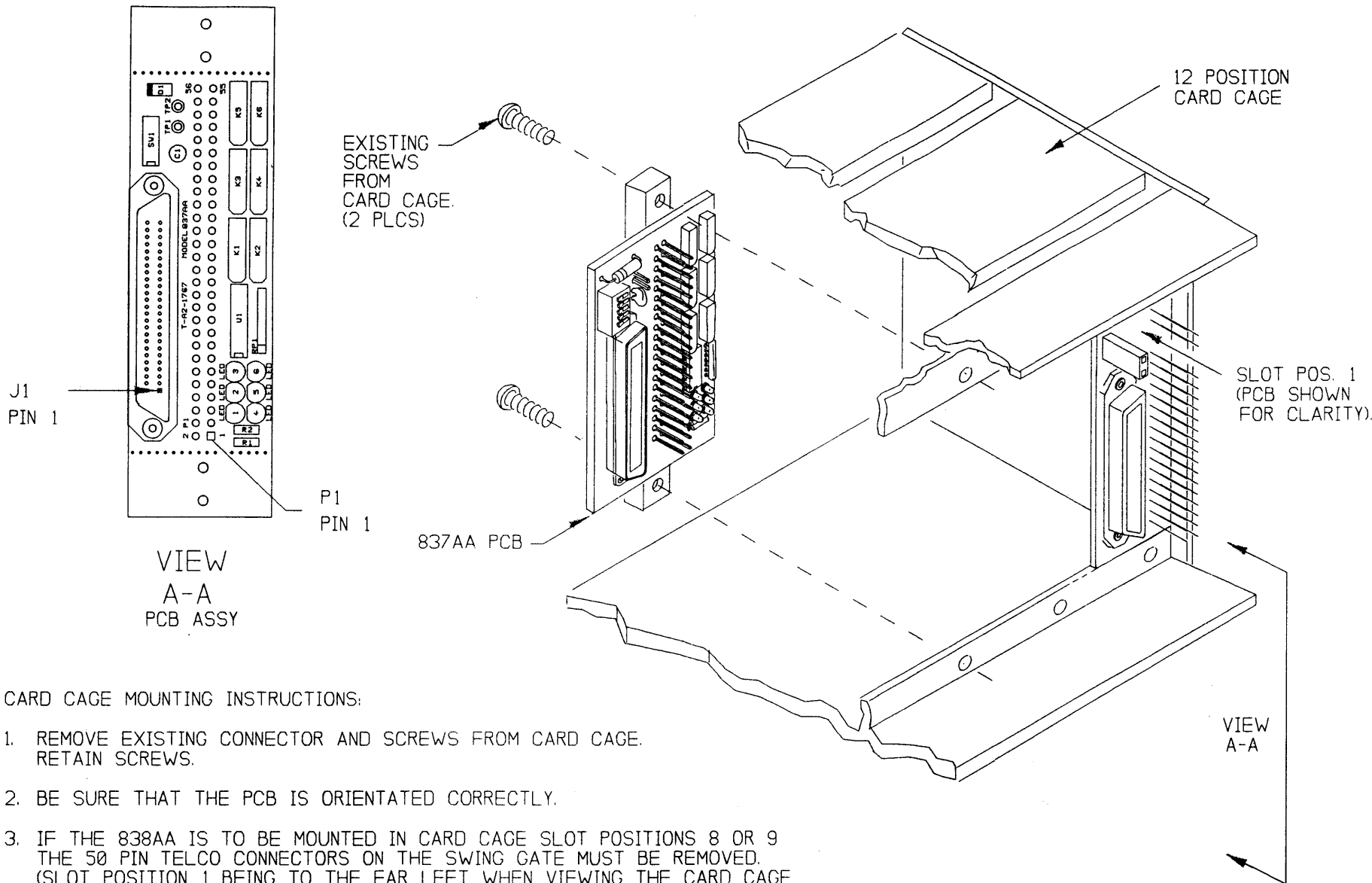

CARD CAGE MOUNTING INSTRUCTIONS:

1. REMOVE EXISTING CONNECTOR AND SCREWS FROM CARD CAGE. RETAIN SCREWS.
2. BE SURE THAT THE PCB IS ORIENTATED CORRECTLY.
3. IF THE 838AA IS TO BE MOUNTED IN CARD CAGE SLOT POSITIONS 8 OR 9 THE 50 PIN TELCO CONNECTORS ON THE SWING GATE MUST BE REMOVED. (SLOT POSITION 1 BEING TO THE FAR LEFT WHEN VIEWING THE CARD CAGE FROM THE FRONT.)
4. THE 838AA ASSEMBLY REQUIRES 2 CARD CAGE SLOTS DUE TO THE WIDTH OF THE 837AA.
5. THE TABS ON BOTH SIDES OF THE 837AA MUST BE CAREFULLY SCORED AND BROKEN OFF. (SEE NOTE (1) ON THE 837AA COMPONENT LOCATOR).

SSC		SOLID-STATE COMMUNICATIONS, INC. 21888 CORSAIR BLVD. HAYWARD CA 94545 U.S.A. (415) 785-4610 TELEEX 33-5364	
REVISIONS 1, 5/29/91	TITLE ASSEMBLY, MODEL 838-AT		
RELEASED	DATE 5-29-91		
DRAWN R.K.	CHECK	SCALE	DRAWING NO.
APPROVED		NONE	A-A2-1768-1

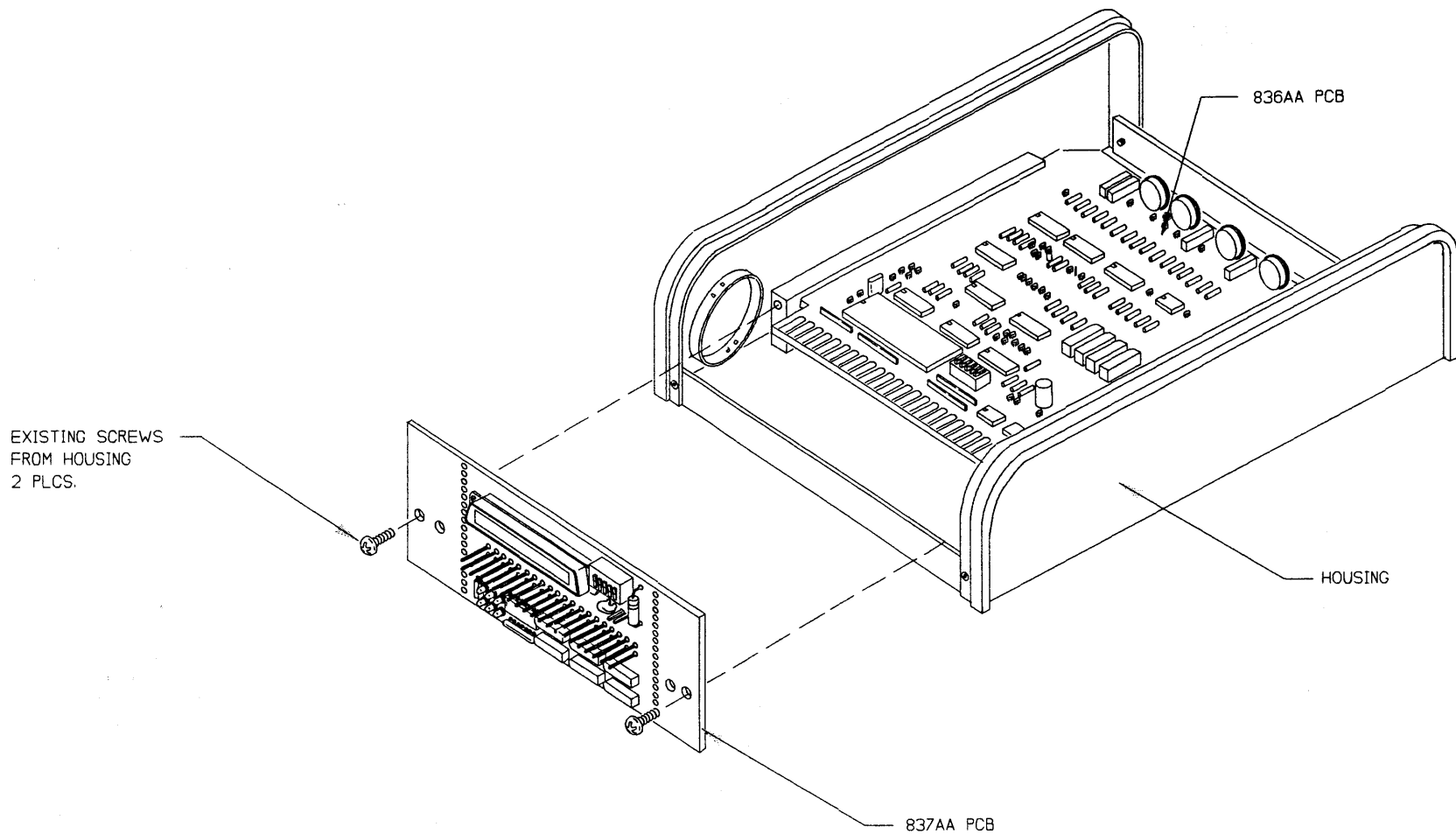

838AA MOUNTING INSTRUCTIONS:

1. REMOVE EXISTING ASSEMBLY FROM HOUSING.
2. REMOVE AND DISCARD SPACER BOARD AND 56 PIN CONNECTOR.
3. REPLACE WITH 837AA PCB ASSY USING EXISTING SCREWS.

SSC		SOLID-STATE COMMUNICATIONS, INC. 21060 CORSAIR BLVD. HAYWARD CA. 94545 U.S.A. (415) 785-1610 TELEX: 33-5364	
REVISIONS	1, 5/28/91	TITLE	
RELEASED		ASSEMBLY, MODEL 838-AW	
DATE	10-25-90		
DRAWN	R.K.	CHECK	SCALE
APPROVED			NONE
		DRAWING NO.	A-A3-1769-1