

CE-5
COMMUNICATIONS
MONITOR



Cushman
Electronics, Inc.

APPLICABLE TO INSTRUMENTS
WITH SERIAL NUMBERS 1721
AND ABOVE

CE-5
COMMUNICATIONS MONITOR

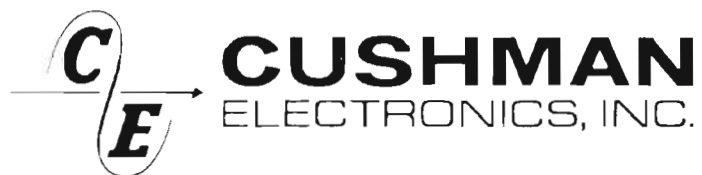

INSTRUMENT MODIFICATION NOTICE

INSTRUMENT CE-5 MODIFICATION M1

230VAC

This instrument has been modified for use with a 230V AC source. The modification consists of:

1. Rewiring the power and isolation transformers and the plug of the left frame assembly (Deviation Meter/Oscilloscope plug-in compartment) for 230V AC.
2. Changing the line fuse to 1/2 Amp Slo Blo and the left frame assembly fuse to 1/10 Amp Slo Blo.
3. Changing the voltage dropping resistor of the OVEN ON lamp to 120k Ω .
4. Replacing the Crystal oven with a 230V AC crystal oven.

The CE-5 instrument manual parts list and schematic diagrams should be changed as follows:

Page 6-95, Front Panel Assembly. A22. Change parts list:

R1 Comp, 120k, $\pm 5\%$, 1/4W 1066-1245 AB CB1245

Page 6-97, Figure 6-20, Interconnection Diagram, Front Panel, Sheet 1. A22.

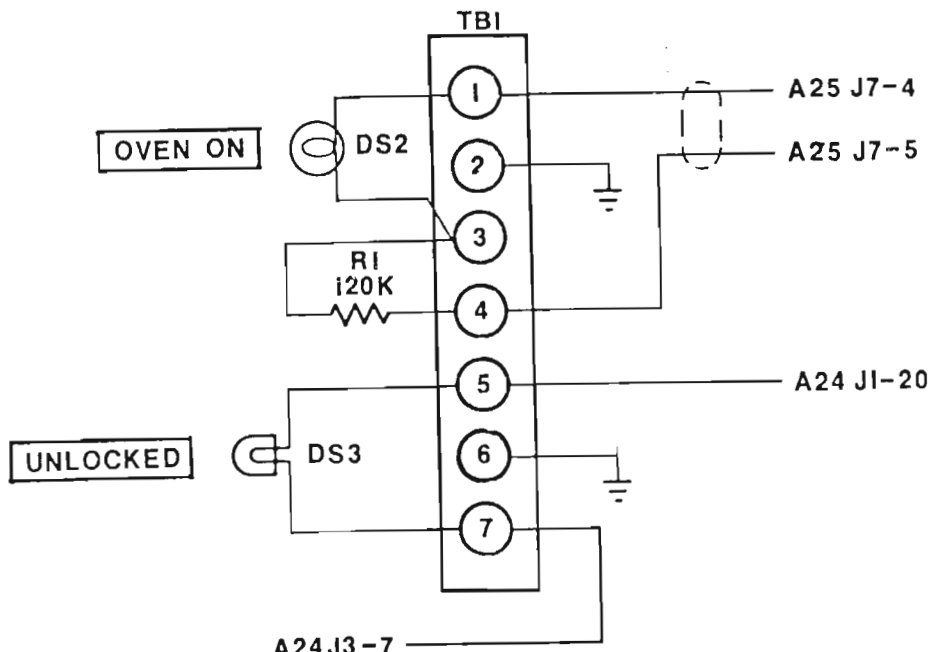

Page 6-101, Rear Panel Assembly. A23. Change parts list:

F1 1/2 Amp, Slo Blo, 3AG 1955-0016 Littelfuse 313.500

INSTRUMENT MODIFICATION NOTICE

Page 6-103, Figure 6-22A. Wiring Diagram, Rear Panel. A23.

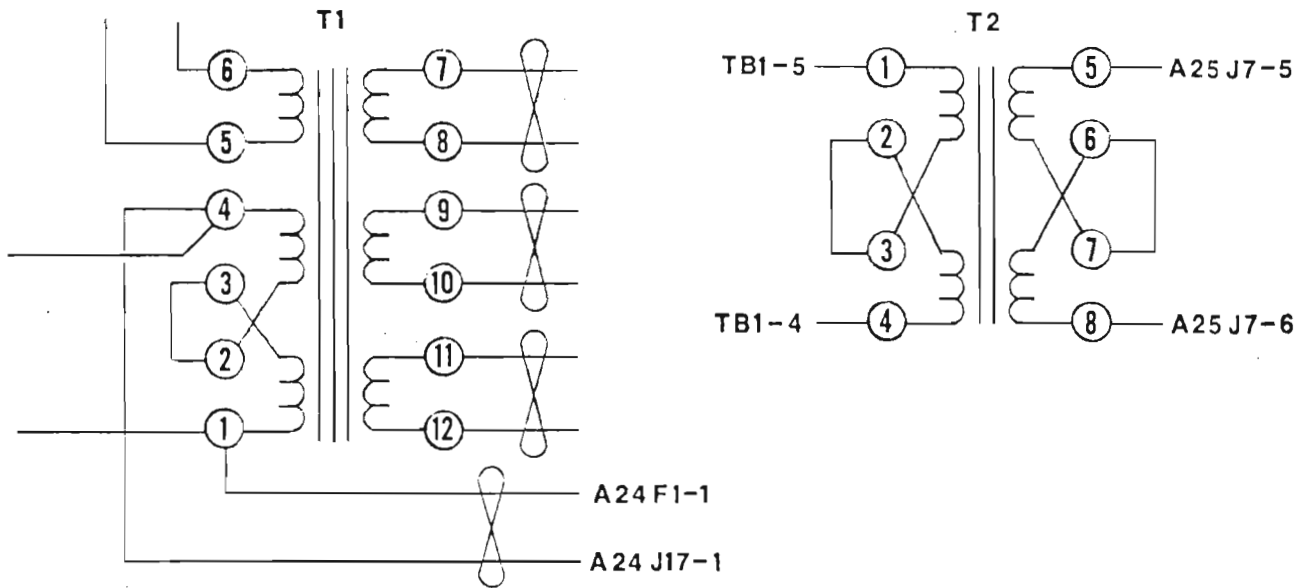

Page 6-105, Main Chassis Assembly. A24. Add to the parts list:

F1 1/10 Amp Slo Blo MDL 1955-0017 Bussman MDL10

Page 6-107, Figure 6-23. Interconnection Diagram, Main Chassis. A24.

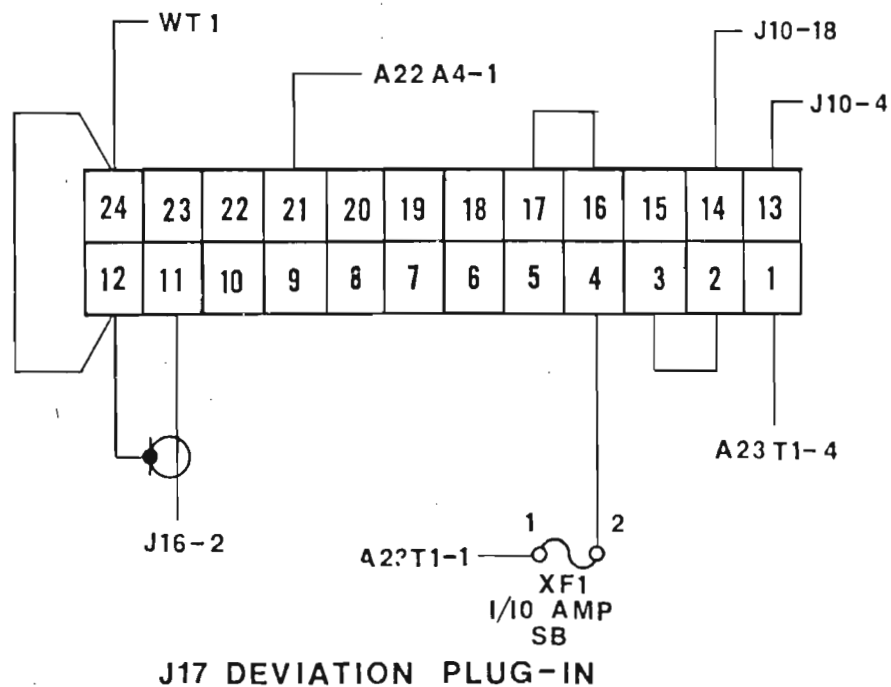

Page 6-109, Center Plate Assembly. A25. Add to the parts list:

OVEN, Crystal 230V AC 2045-0005 Cushman



INSTRUMENT MODIFICATION NOTICE

INSTRUMENT CE-5 MODIFICATION M-2

HIGH SENSITIVITY FREQUENCY ERROR METER

The M2 modification has been installed in this instrument. The purpose of this modification is to increase the resolution and sensitivity of the Frequency Meter. Full scale ranges are now (as marked on the switch nameplate) ± 5 kHz, ± 1.5 kHz, ± 5 kHz in the FREQ-DEV. MEASURE mode. In the CAL mode the full scale range is ± 5 kHz, and in the FM Signal Generating mode it is ± 5 kHz.

The modification is made by installing a more sensitive FREQUENCY meter and changing the value of four resistors in the meter circuit. Refer to parts list given below. One wiring change is made so that in the FM Signal Generating mode the meter range will remain at ± 5 kHz. The blue wire connection from Function Switch A22S8-A1 is removed from kHz switch A22S7-2 and connected to A22S7-1. A blue and a gray wire are now connected to A22S7-1.

The parts list and schematic diagram in your manual should be corrected to show these changes. (See parts list pages 6-15, 6-95 and Schematic Diagram page 6-17.)

Ckt. Ref.	Description	C/E Stock No.	Mfr.
R1	Comp, 47K, $\pm 5\%$, 1/4W	1066-4735	A-B
R2	Comp, 10K, $\pm 5\%$, 1/4W	1066-1035	A-B
R3	Comp, 1K, $\pm 5\%$, 1/4W	1066-1025	A-B
R7	Comp, 10K, $\pm 5\%$, 1/4W	1066-1035	A-B
M1	Frequency-Error Meter	1402-0019	Cushman

HOOD TO BE USED WITH CUSHMAN MODEL 301 & 301A

VIEWING HOOD INSTRUCTIONS

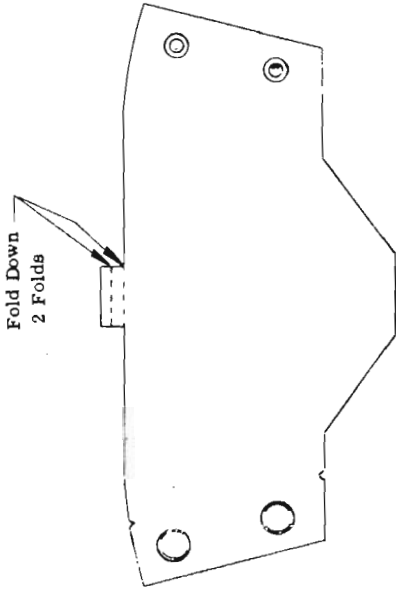

STEP 1



Overlap and snap buttons.

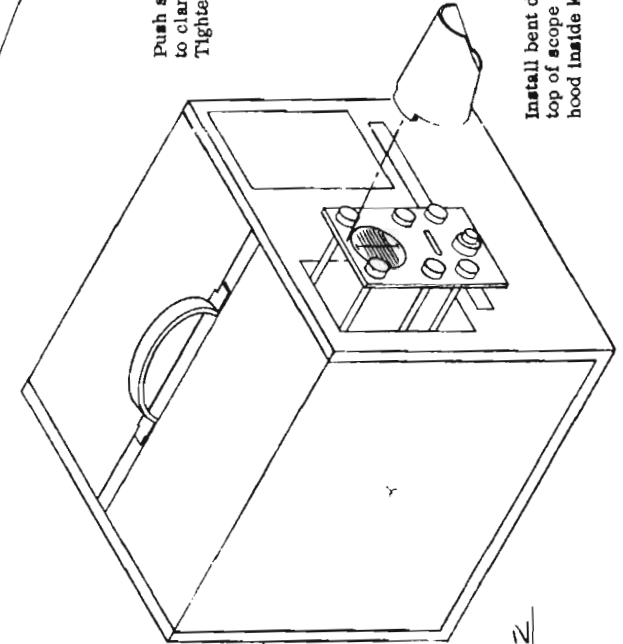

Loosen lock nut on rear of monitor and push scope away from front panel.

STEP 2

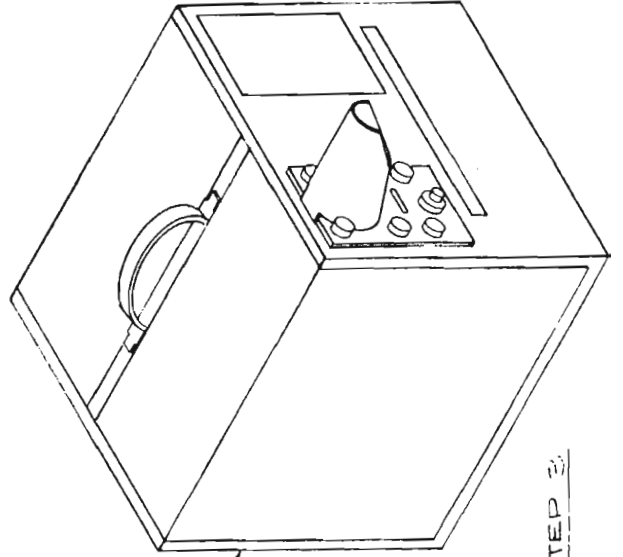

Push scope back into monitor to clamp tab. Tighten nut on rear of monitor.

Install bent down tab over top of scope front panel with hood inside knobs.

STEP 3

MANUAL CHANGE NOTICE

INSTRUMENT CE-5 MANUAL NO. 5601-0071 DATE PRINTED October 1976

The following changes are necessary to bring your manual up to date. Changes are listed with the instrument serial numbers to which they apply. It is suggested that you enter these changes in your manual immediately.

All serial numbers.

In Table 1-1, Specifications, p. 1-3, change the Frequency Accuracy to read 0.00001% ± Time Base.

Serial number 1886 and up.

Table 2-1, p. 2-2, Auxiliary Items Furnished with CE-5, Item 1, Fuse, RF, change value to read 1/10 Amp and change Cushman Stock Number to 1955-0032. Item 5, 20 dB Fixed Attenuator Adapter Cable Assembly, change Cushman Stock number to 7040-0049.

Section 3.10a, p. 3-4, add the following NOTE:

An 800 MHz antenna which will plug into the ANT connector may be made from a banana jack (GC Electronics #33-002) and a 3 inch length of #12 tinned wire. Assemble according to the following illustration:

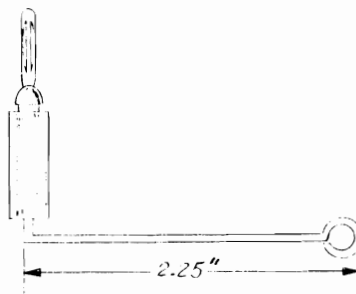

Serial number 1886 and up.

Parts List, p. 6-16, Second IF/Discriminator, A5, add to R30, "FSV".

Schematic diagram, p. 6-19, Figure 6-4, Second IF/Discriminator, A5, add terminals at each end of R30 for addition of a resistor in parallel and label "FSV".

5614-0056

Date June 1978

Sheet 1 of 15

Serial number 1916 and up.

Parts List, p. 6-22, Master Oscillator/Divider/Filters, A6, change L3 as follows:

L3 RF Choke, 43mH, $\pm 5\%$ 1585-0060 Delevan 1537-58

Schematic Diagram, p. 6-25, Figure 6-5, Master Oscillator/Divider/Filters, A6, change the value of L3 to 43.

All serial numbers.

Schematic Diagram, p. 6-25, Master Oscillator/Divider/Filters, A6, change the connection of C34 and C40 as shown below:

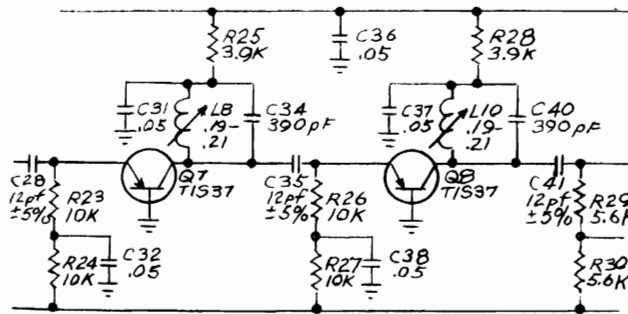

Serial number 1721 and up.

Parts List, p. 6-37, 4600-50.99 MHz X10 Multiplier, A9, change C27 and add C29 as follows:

C27	Cap, 2-8pF, 350V, Vert Trim	1001-0004	Erie	538-002A-2-8-89A
C29	Cap, 15-60pF, 200V, NPO Trim	1001-0016	Erie	538-002F-15-60

Schematic Diagram, p. 6-39, 46.00-50.99 MHz, X10 Multiplier, A9, change C27 and add C29 as shown below:

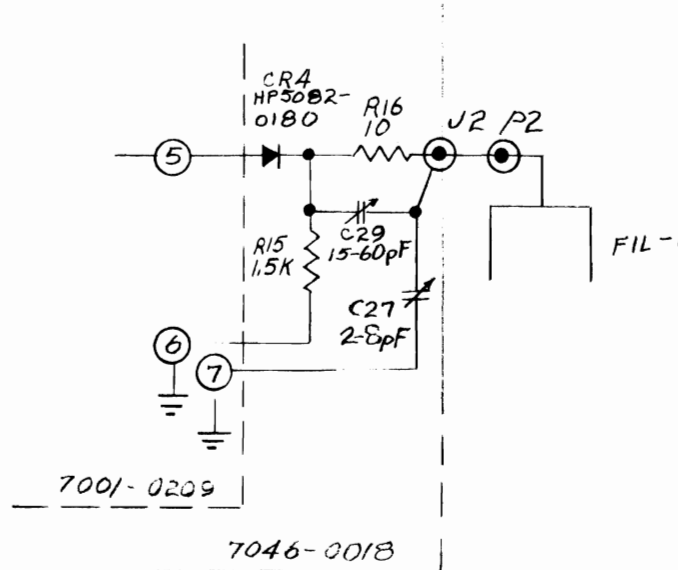

Serial number 1610 and up.

Parts List, p. 6-38, 46.00-50.99 MHz X10 Multiplier, A9, change R6, R13, and add R12 as follows:

R6	Comp, 820Ω, ±5%, 1/4W	1066-8215	Allen-Bradley	CB8215
R12	Comp, 150Ω, ±5%, 1/4W	1066-1515	Allen-Bradley	CB1515
R13	Comp, 15Ω, ±5%, 1/4W	1066-1505	Allen-Bradley	CB1505

All serial numbers.

Parts List, p. 6-51, Power Supply Regulator, A12, change CR4 as follows:

CR4	Si, Zener, 3.6V, ±5%, 1N747A	1281-0076	Motorola	1N747A
-----	------------------------------	-----------	----------	--------

Serial number 1886 and up.

Parts List, p. 6-73, Programmable Phase Lock Loop and Amplifier, A17, change C6 to FSV and change C36 as follows:

C36	Elect, 10μF, ±10%, 25V	1013-0035	Sprague	503D106G025AS
-----	------------------------	-----------	---------	---------------

Schematic Diagram, p. 6-77, Figure 6-16, Programmable Phase Lock Loop and Amplifier, A17, change C6 to FSV.

Serial number 1886 and up.

Parts List, p. 6-79 to 6-82 and Schematic Diagram, p. 6-83, 10 MHz Modulator, A18, P. C. Board Assembly has been changed. New P. C. Board Assembly, 7001-0443 is now used. New parts list and schematic diagram for 7001-0443 assembly is attached. Table 6-1, p. 6-1, change A18 Assembly No. to 7001-0443.

Serial number 1801 and up.

Parts List, p. 6-86 to 6-90, and Schematic Diagram, p. 6-91, change the following components to FSV: L1, L2, L12, L25, R68, R76.

Serial number 1916 and up.

Parts List, p. 6-111, 20 dB pad assembly, change pad assembly number to 7040-0049. Change fuse, resistor and add fuse holder as follows:

F1	Fuse, 1/10 amp	1955-0032	Littelfuse	273.100
XF1	Fuse Holder	1965-0014	Littelfuse	281005
R2	Comp, 240Ω, ±5%, 1/4W	1066-2415	Allen-Bradley	CB2415

Schematic Diagram, p. 6-113, 20 dB pad assembly, change value of F1 to 1/10 amp and R2 to 240.

Serial number 1801 and up.

Parts List and Schematic Diagram, p. 6-115 to 6-119, Output Attenuator, A20, P. C. Board assembly has been changed. New P. C. Board assembly, 7001-0272 is now used. New parts list and schematic diagram for 7001-0272 assembly is attached. Table 6-1, p. 6-1, change A20 Assembly No. to 7001-0272.

All serial numbers.

In Table 1-1, Specifications, p. 1-3, change the External FM Modulation specification as follows:

Modulation		
FM	External Frequency	
	Standard	20 Hz - 5 kHz
	Optional	
	Sine	5 Hz - 5 kHz
	Square	5 Hz - 1 kHz
	Pulse	5 Hz (5% to 95% duty cycle)

Serial number 2086 and up.

Parts List, p. 6-15, Second IF/Discriminator, A5, add L13 as follows:

L13 Choke, U-250, Ferrite Bead 1586-0004 Ferroxcube 56-590-65/4B

Schematic Diagram, p. 6-19/6-20, Figure 6-4, Second IF/Discriminator, A5, add L13 to the base of Q9 as shown below:

10 MHz MODULATOR, A18

CKT. REF.	DESCRIPTION	CE STOCK NO.	MFR.	MFR. NO.
A18	PCB Assy, 10 MHz Modulator PC Board	7001-0443 1780-0449	Cushman Cushman	
	CAPACITORS			
C1	Cap, .027 μ F, 10%, 100V	1008-0032	Sprague	225P27391
C2	Cap, 2.2 μ F, 10%, 35V	1011-0001	Dickson	D2R2GSB35K
C3	Cap, .022 μ F, 1%, 100V	1008-0082	IMB	XA2B223F
C4	Cap, 330PF, 5%, 500V Mica	1002-0032	Elmenco	DM15-F331J
C5	Cap, .1 μ F, 10%, 100V	1008-0031	Sprague	225P10491WA3
C6	Cap, 820PF, 5%, 300V Mica	1002-0039	Elmenco	DM15-F-821J
C7	Cap, .022 μ F, 1%, 100V	1008-0082	IMB	XA2B223F
C8	Not Used			
C9	Cap, 180PF, 5%, 500V Mica	1002-0005	Elmenco	DM15-F-181J
C10	Cap, 22PF, 5%, 500V Mica	1002-0023	Elmenco	DM15-C-220J
C11	Cap, .01 μ F, +80-20%, 25V Disc	1005-0013	Erie	5835-512-Y5U-103Z
C12	Cap, 22PF, 2%, 500V Tub	1005-0007	Erie	301-000-U2J0-220G
C13	Cap, .022 μ F, 1%, 100V	1008-0082	IMB	XA2B223F
C14	Cap, 470PF, 5%, 500V Mica	1002-0035	Elmenco	DM15-F-471J
C15	Cap, 470PF, 5%, 500V Mica	1002-0035	Elmenco	DM15-F-471J
C16	Cap, .05 μ F, +80-20%, 25V Disc	1005-0014	Erie	5855-505-Y5U0-503Z
C17	Cap, 15PF, 5%, 500V Mica	1002-0001	Elmenco	DM15-C-150J
C18	Cap, .1 μ F, 10%, 100V	1008-0031	Sprague	225P10491WA3
C19	Not Used			
C20	Cap, .05 μ F, +80-20%, 25V Disc	1005-0014	Erie	5855-505-Y5U0-503Z
C21	Cap, 390PF, 5%, 500V Mica	1002-0033	Elmenco	DM15-F-391J
C22	Cap, 820PF, 5%, 300V Mica	1002-0039	Elmenco	DM15-F-821J
C23	Cap, 20PF, 5%, 500V Mica	1002-0060	Elmenco	DM15-E-200J
C24	Cap, .05 μ F, +80-20%, 25V Disc	1005-0014	Erie	5855-505-Y5U0-503Z
C25	Cap, .01 μ F, +80-20%, 25V Disc	1005-0013	Erie	5835-512-Y5U-103Z
C26	Not Used			
C27	Cap, .05 μ F, +80-20%, 25V Disc	1005-0014	Erie	5855-505-Y5U0-503Z
C28	Cap, 10 μ F, +50-20%, 35V	1011-0006	ITT	TAG 10/35-20
C29	Cap, 470PF, 5%, 500V Mica	1002-0035	Elmenco	DM15-F-471J
C30	Cap, .05 μ F, +80-20%, 25V Disc	1005-0014	Erie	5855-505-Y5U0-503Z
C31	Cap, .05 μ F, +80-20%, 25V Disc	1005-0014	Erie	5855-505-Y5U0-503Z
C32	Cap, .002 μ F, 20%, 500V Disc	1005-0003	Erie	831-596-Z5U-202M
C33	Cap, 100 μ F, 20%, 20V	1011-0010	Kemet	T362D107M020AS
C34	Cap, .05 μ F, +80-20%, 25V Disc	1005-0014	Erie	5855-505-Y5U0-503Z
C35	Cap, .05 μ F, +80-20%, 25V Disc	1005-0014	Erie	5855-505-Y5U0-503Z
C36	Cap, .01 μ F, +80-20%, 25V Disc	1005-0013	Erie	5835-512-Y5U-103Z
C37	Cap, 430PF, 5%, 500V Mica	1002-0034	Elmenco	DM15-F-431J
C38	Cap, .05 μ F, +80-20%, 25V Disc	1005-0014	Erie	5855-505-Y5U0-503Z
C39	Cap, .0033 μ F, 10%, 100V	1008-0041	Sprague	225P33291WA3
C40	Cap, 470PF, 5%, 500V Mica	1002-0035	Elmenco	DM15-F-471J
C41	Cap, 10 μ F, +50-20%, 35V	1011-0006	ITT	TAG 10/35-20
C42	Cap, 4.7PF, .25PF%, 500V Tub	1005-0015	Erie	301-000-C0H0-479C
C43	Cap, .05 μ F, +80-20%, 25V Disc	1005-0014	Erie	5855-505-Y5U0-503Z
C44	Cap, .05 μ F, +80-20%, 25V Disc	1005-0014	Erie	5855-505-Y5U0-503Z
C45	Cap, .05 μ F, +80-20%, 25V Disc	1005-0014	Erie	5855-505-Y5U0-503Z

10 MHz MODULATOR (cont) A18

CKT. REF.	DESCRIPTION	CE STOCK NO.	MFR.	MFR. NO.
C46	Cap, .05 μ F, +80-20%, 25V Disc	1005-0014	Erie	5855-505-Y5U0-503Z
C47	Cap, .05 μ F, +80-20%, 25V Disc	1005-0014	Erie	5855-505-Y5U0-503Z
C48	Cap, .05 μ F, +80-20%, 25V Disc	1005-0014	Erie	5855-505-Y5U0-503Z
C49	Cap, 10 μ F, +50-20%, 35V	1011-0006	ITT	TAG 10/35-20
C50	Cap, 100 μ F, 20%, 20V	1011-0010	Kemet	T362D107M020AS
DIODES				
CR1	Diode, MV1638	1281-0059	Motorola	MV1638
CR2	Diode, MPN3401	1281-0050	Motorola	MPN3401
CR3	Diode, 1N3064	1281-0013	Teledyne	1N3064
CR4	Diode, 1N3064	1281-0013	Teledyne	1N3064
CR5	Diode, 1N3064	1281-0013	Teledyne	1N3064
CR6	Diode, 1N3064	1281-0013	Teledyne	1N3064
CR7	Diode, HPA2800	1283-0001	HPA	5082-2800
CR8	Diode, 1N3064	1281-0013	Teledyne	1N3064
CR9	Diode, HPA2800	1283-0001	HPA	5082-2800
CR10	Diode, 1N3064	1281-0013	Teledyne	1N3064
CR11	Diode, 1N3064	1281-0013	Teledyne	1N3064
INDUCTORS				
L1	Choke, 82 μ H, 5%	1585-0032	Delevan	1537-72
L2	Coil, 3.8 to 7.3 μ H	1596-0025	Delevan	4000-18
L3	Coil, 8 Turn 16 MHz	1596-0111	Cushman	
L4	Coil, 8 Turn 16 MHz	1596-0111	Cushman	
L5	Choke, .56 μ H, 10%	1585-0036	Delevan	1840-07
L6	Coil, 8 Turn 16 MHz	1596-0111	Cushman	
TRANSISTORS				
Q1	Trans, 2N3565	1272-0017	Fairchild	2N3565
Q2	Trans, 2N4391	1272-0042	Teledyne	2N4391
Q3	Trans, 2N4275	1272-0016	Fairchild	2N4275
Q4	Trans, TIS 37	1271-0003	T.I.	TIS37
Q5	Trans, 2N3904	1272-0032	Motorola	2N3904
Q6	Trans, 2N4121	1272-0023	Fairchild	2N4121
Q7	Trans, 2N4275	1272-0016	Fairchild	2N4275
Q8	Trans, 2N3904	1272-0032	Motorola	2N3904
Q9	Trans, 2N3904	1272-0032	Motorola	2N3904
Q10	Trans, 2N3565	1272-0017	Fairchild	2N3565
Q11	Trans, 2N4121	1272-0023	Fairchild	2N4121
Q12	Trans, 2N4121	1272-0023	Fairchild	2N4121
Q13	Trans, 2N3565	1272-0017	Fairchild	2N3565
Q14	Trans, 2N3904	1272-0032	Motorola	2N3904
Q15	Trans, 2N4121	1272-0023	Fairchild	2N4121
RESISTORS				
R1	Res, 18K, 5%, 1/4W Comp	1066-1835	Allen-Bradley	CB1835
R2	Res, 2 Meg, 5%, 1/4W Comp	1066-2055	Allen-Bradley	CB2055
R3	Res, 294K, 1%, 1/8W MF	1075-0028	Dale	MF 1/8
R4	Res, 220K, 5%, 1/4W Comp	1066-2245	Allen-Bradley	CB2245
R5	Res, 560 Ohm, 5%, 1/4W Comp	1066-5615	Allen-Bradley	CB5615

10 MHz MODULATOR (cont) A18

CKT. REF.	DESCRIPTION	CE STOCK NO.	MFR.	MFR. NO.
R6	Res, 1.2 Meg, 5%, 1/4W Comp	1066-1255	Allen-Bradley	CB1255
R7	Res, 10K, 1%, 1/8W MF	1075-0009	Dale	MF 1/8
R8	Res, 2.49K, 1%, 1/8W MF	1075-0027	Dale	MF 1/8
R9	Res, 137 Ohm, 1%, 1/8W MF	1075-0026	Dale	MF 1/8
R10	Res, 10K, 1%, 1/8W MF	1075-0009	Dale	MF 1/8
R11	Res, 5.6K, 5%, 1/4W Comp	1066-5625	Allen-Bradley	CB5625
R12	Res, 2.2K, 5%, 1/4W Comp	1066-2225	Allen-Bradley	CB2225
R13	Res, 10K, 5%, 1/4W Comp	1066-1035	Allen-Bradley	CB1035
R14	Res, 1 Meg, 5%, 1/4W Comp	1066-1055	Allen-Bradley	CB1055
R15	Res, 10K, 5%, 1/4W Comp	1066-1035	Allen-Bradley	CB1035
R16	Res, 8.2K, 5%, 1/4W Comp	1066-8225	Allen-Bradley	CB8225
R17	Res, 8.2K, 5%, 1/4W Comp	1066-8225	Allen-Bradley	CB8225
R18	Res, 10K, 5%, 1/4W Comp	1066-1035	Allen-Bradley	CB1035
R19	Res, 1.8K, 5%, 1/4W Comp	1066-1825	Allen-Bradley	CB1825
R20	Res, 1.2K, 5%, 1/4W Comp	1066-1225	Allen-Bradley	CB1225
R21	Res, 620 Ohm, 5%, 1/4W Comp	1066-6215	Allen-Bradley	CB6215
R22	Res, 8.2K, 5%, 1/4W Comp	1066-8225	Allen-Bradley	CB8225
R23	Res, 10 Ohm, 5%, 1/4W Comp	1066-1005	Allen-Bradley	CB1005
R24	Res, 2.2K, 5%, 1/4W Comp	1066-2225	Allen-Bradley	CB2225
R25	Res, 5.1K, 5%, 1/4W Comp	1066-5125	Allen-Bradley	CB5125
R26	Res, 10 Ohm, 5%, 1/4W Comp	1066-1005	Allen-Bradley	CB1005
R27	Res, 10 Ohm, 5%, 1/4W Comp	1066-1005	Allen-Bradley	CB1005
R28	Res, 120 Ohm, 5%, 1/4W Comp	1066-1215	Allen-Bradley	CB1215
R29	Not Used			
R30	Res, 43 Ohm, 5%, 1/4W Comp	1066-4305	Allen-Bradley	CB4305
R31	Res, 5.6K, 5%, 1/4W Comp	1066-5625	Allen-Bradley	CB5625
R32	Res, 10K, 5%, 1/4W Comp	1066-1035	Allen-Bradley	CB1035
R33	Res, 10K, 5%, 1/4W Comp	1066-1035	Allen-Bradley	CB1035
R34	Res, 33K, 5%, 1/4W Comp	1066-3335	Allen-Bradley	CB3335
R35	Res, 15K, 5%, 1/4W Comp	1066-1535	Allen-Bradley	CB1535
R36	Res, 4.7 Ohm, 5%, 1/4W Comp	1066-0001	Ohmite	OB47G5
R37	Pot, 500 Ohm, 10%, 3/4W	1215-0011	Helitrim	89 WR
R38	Res, 10K, 5%, 1/4W Comp	1066-1035	Allen-Bradley	CB1035
R39	Res, 4.7K, 5%, 1/4W Comp	1066-4725	Allen-Bradley	CB4725
R40	Res, 4.7 Ohm, 5%, 1/4W Comp	1066-0001	Ohmite	OB47G5
R41	Pot, 500 Ohm, 10%, 3/4W	1215-0011	Helitrim	89 WR
R42	Res, 33K, 5%, 1/4W Comp	1066-3335	Allen-Bradley	CB3335
R43	Res, 10K, 5%, 1/4W Comp	1066-1035	Allen-Bradley	CB1035
R44	Res, 10K, 5%, 1/4W Comp	1066-1035	Allen-Bradley	CB1035
R45	Res, 5.1K, 5%, 1/4W Comp	1066-5125	Allen-Bradley	CB5125
R46	Res, 100 Ohm, 5%, 1/4W Comp	1066-1015	Allen-Bradley	CB1015
R47	Res, 10K, 5%, 1/4W Comp	1066-1035	Allen-Bradley	CB1035
R48	Res, 4.7 Ohm, 5%, 1/4W Comp	1066-0001	Ohmite	OB47G5
R49	Pot, 500 Ohm, 10%, 3/4W	1215-0011	Helitrim	89 WR
R50	Res, 1.8K, 5%, 1/4W Comp	1066-1825	Allen-Bradley	CB1825
R51	Res, 1K, 5%, 1/4W Comp	1066-1025	Allen-Bradley	CB1025
R52	Res, 10K, 5%, 1/4W Comp	1066-1035	Allen-Bradley	CB1035
R53	Res, 10K, 5%, 1/4W Comp	1066-1035	Allen-Bradley	CB1035
R54	Res, 18 Ohm, 5%, 1/4W Comp	1066-1805	Allen-Bradley	CB1805
R55	Res, 300 Ohm, 5%, 1/4W Comp	1066-3015	Allen-Bradley	CB3015

10 MHz MODULATOR (cont) A18

CKT. REF.	DESCRIPTION	CE STOCK NO.	MFR.	MFR. NO.
R56	Res, 300 Ohm, 5%, 1/4W Comp	1066-3015	Allen-Bradley	CB3015
R57	Res, 4.7K, 5%, 1/4W Comp	1066-4725	Allen-Bradley	CB4725
R58	Res, 27K, 5%, 1/4W Comp	1066-2735	Allen-Bradley	CB2735
R59	Res, 1K, 5%, 1/4W Comp	1066-1025	Allen-Bradley	CB1025
R60	Res, 3.3K, 5%, 1/4W Comp	1066-3325	Allen-Bradley	CB3325
R61	Res, 4.7 Ohm, 5%, 1/4W Comp	1066-0001	Ohmite	OB47G5
R62	Pot, 500 Ohm, 10%, 3/4W	1215-0011	Helitrim	89WR
R63	Res, 5.6K, 5%, 1/4W Comp	1066-5625	Allen-Bradley	CB5625
R64	Res, 1K, 5%, 1/4W Comp	1066-1025	Allen-Bradley	CB1025
R65	Res, 1K, 5%, 1/4W Comp	1066-1025	Allen-Bradley	CB1025
R66	Res, 22K, 5%, 1/4W Comp	1066-2235	Allen-Bradley	CB2235
R67	Res, 3.3K, 5%, 1/4W Comp	1066-3325	Allen-Bradley	CB3325
R68	Res, 4.7K, 5%, 1/4W Comp	1066-4725	Allen-Bradley	CB4725
R69	Res, 6.2K, 5%, 1/4W Comp	1066-6225	Allen-Bradley	CB6225
R70	Res, 1K, 5%, 1/4W Comp	1066-1025	Allen-Bradley	CB1025
R71	Res, 10K, 5%, 1/4W Comp	1066-1035	Allen-Bradley	CB1035
R72	Res, 100K, 5%, 1/4W Carbon Comp	1066-1045	Allen-Bradley	CB1045
R73	Res, 100K, 5%, 1/4W Carbon Comp	1066-1045	Allen-Bradley	CB1045
R74	Not Used			
R75	Res, 2.2K, 5%, 1/4W Comp	1066-2225	Allen-Bradley	CB2225
R76	Res, 6.2K, 5%, 1/4W Comp	1066-6225	Allen-Bradley	CB6225
R77	Res, 4.7K, 5%, 1/4W Comp	1066-4725	Allen-Bradley	CB4725
R78	Res, 2.4K, 5%, 1/4W Comp	1066-2425	Allen-Bradley	CB2425
R79	Res, 3.3K, 5%, 1/4W Comp	1066-3325	Allen-Bradley	CB3325
INTEGRATED CIRCUITS				
U1	IC, N5558V, Dual Op Amp	2025-0058	Signetics	N5558V
U2	IC, SN72741P	2025-0067	T. I.	SN72741P

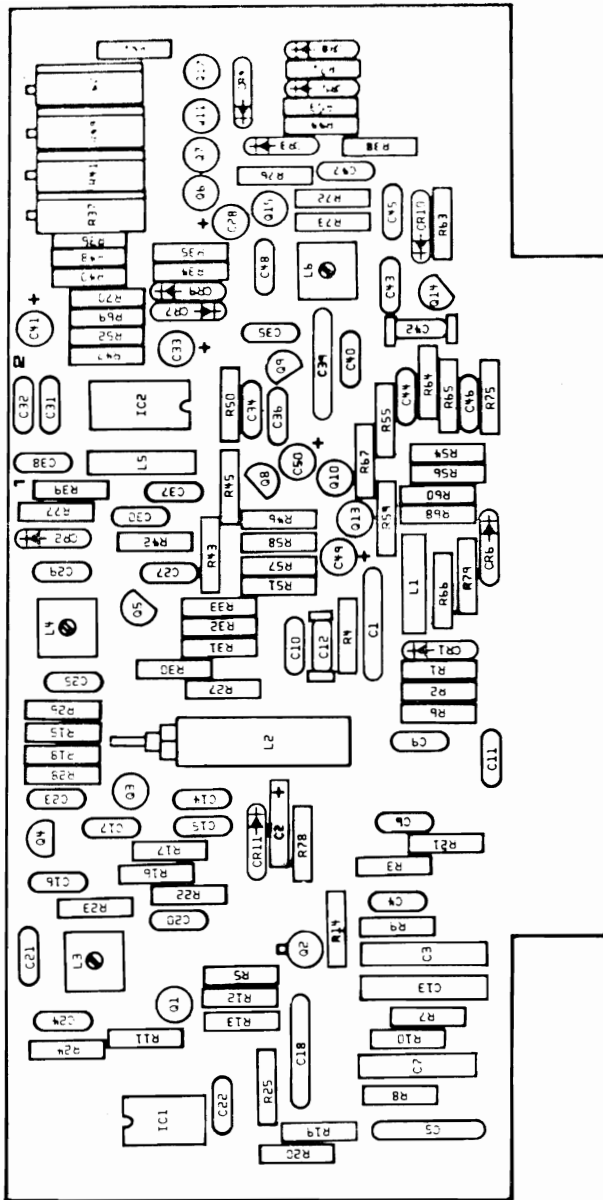
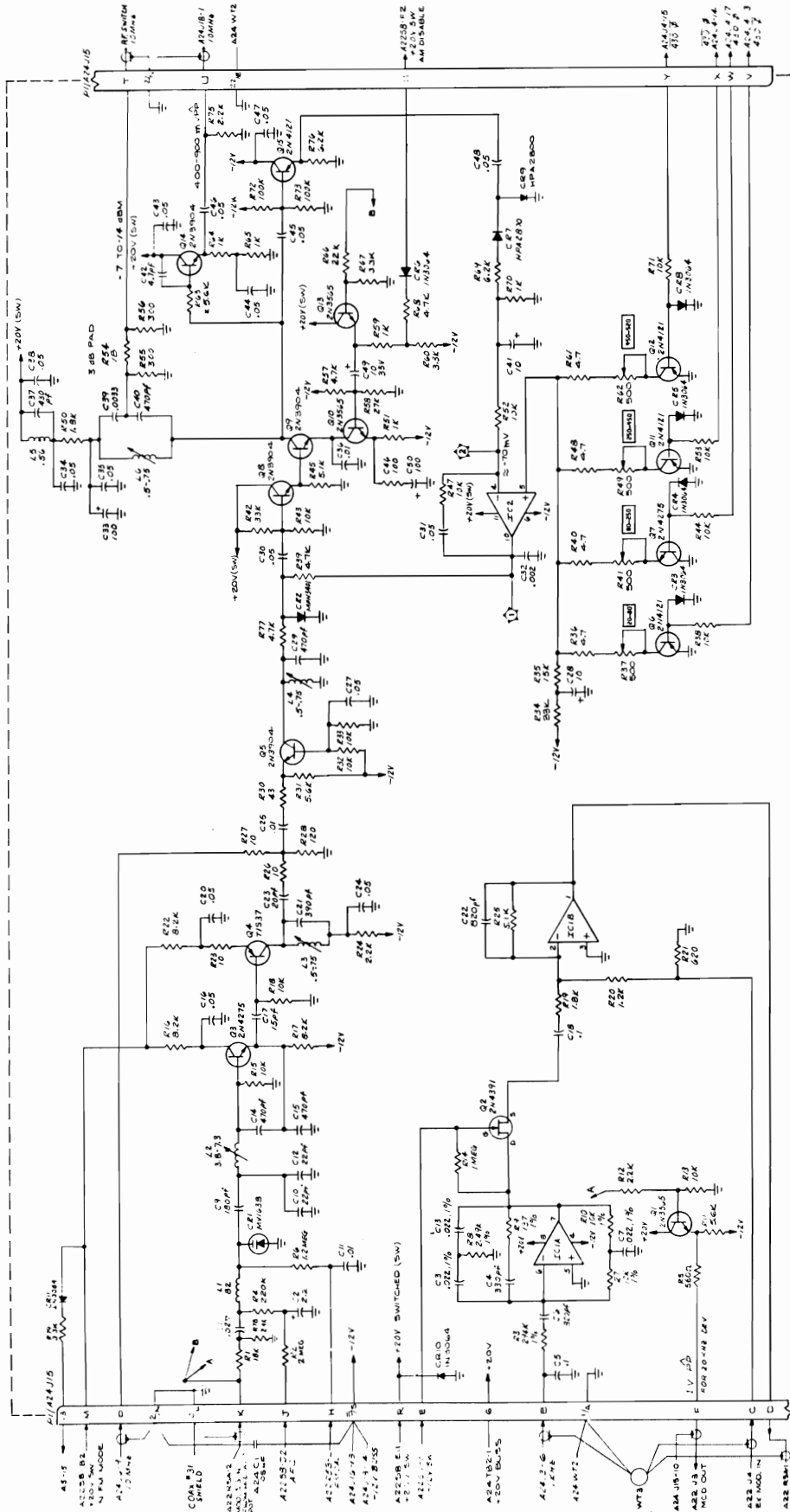

Figure 6-17a. 10 MHz Modulator. A18



IC NO	TYPE
1	2N255B
2	2N7274M

- NOTE:
1. RESISTORS - 1% UNLESS OTHERWISE NOTED.
 2. CAPACITORS - UNLESS OTHERWISE NOTED.
 3. DIODES - UNLESS OTHERWISE NOTED.
 4. TRANSISTORS - UNLESS OTHERWISE NOTED.
 5. ALL UNITS ARE UNLESS OTHERWISE NOTED.

Figure 6-17. 10 MHz Modulator, A18

6-83/6-84

5601-0071-1

OUTPUT ATTENUATOR. A20

CKT. REF.	DESCRIPTION	CE STOCK NO.	MFR.	MFR. NO.
A20	PC Bd Assy, Output Attenuator CE5 PC Board	7001-0272 1780-0461	Cushman Cushman	
	CAPACITORS			
C1	Cap, 1000PF, 10%, 100V Min Cer	1005-0081	Erie	8121-100-W5R-102K
C2	Cap, 1000PF, 10%, 100V Min Cer	1005-0081	Erie	8121-100-W5R-102K
C3	Cap, 1000PF, 10%, 100V Min Cer	1005-0081	Erie	8121-100-W5R-102K
C4	Cap, 1000PF, 10%, 100V Min Cer	1005-0081	Erie	8121-100-W5R-102K
C5	Cap, 1000PF, 10%, 100V Min Cer	1005-0081	Erie	8121-100-W5R-102K
C6	Cap, 1000PF, 10%, 100V Min Cer	1005-0081	Erie	8121-100-W5R-102K
C7	Cap, 1000PF, 10%, 100V Min Cer	1005-0081	Erie	8121-100-W5R-102K
C8	Cap, 1000PF, 10%, 100V Min Cer	1005-0081	Erie	8121-100-W5R-102K
C9	Cap, 1000PF, 10%, 100V Min Cer	1005-0081	Erie	8121-100-W5R-102K
C10	Cap, 12PF, 5%, 500V Mica	1002-0017	Elmenco	DM15-C-120J
C11	Cap, 15 μ F, 10%, 25V	1013-0005	Sprague	30D156G025BB5
C12	Cap, .01 μ F, +80-20%, 25V Disc	1005-0013	Erie	5835-512-Y5U-100Z
C13	Cap, 10PF, 5%, 500V Mica	1002-0016	Elmenco	DM15-C-100J
C14	Cap, 39PF, 5%, 500V Mica	1002-0018	Elmenco	DM15-E-390J
C15	Cap, .01 μ F, 20%, 100V Mini	1005-0100	Erie	8121-100-651-103M
C16	Cap, .01 μ F, 20%, 100V Mini	1005-0100	Erie	8121-100-651-103M
C17	Cap, .01 μ F, 20%, 100V Mini	1005-0100	Erie	8121-100-651-103M
C18	Cap, .01 μ F, 20%, 100V Mini	1005-0100	Erie	8121-100-651-103M
C19	Cap, 10 μ F, 10%, 20V	1011-0007	Kemet	K10C20K
C20	Cap, .05 μ F, +80-20%, 25V Disc	1005-0014	Erie	5855-505-Y5U0-503Z
C21	Not Used			
C22	Not Used			
C23	Not Used			
C24	Not Used			
C25	Not Used			
C26	Not Used			
C27	Cap, 220PF, 10%, 100V Mini	1005-0075	Erie	8101-A100-W5R0-221K
	DIODES			
CR1	Diode, MPN3401	1281-0050	Motorola	MPN3401
CR2	Diode, MPN3401	1281-0050	Motorola	MPN3401
CR3	Diode, MPN3401	1281-0050	Motorola	MPN3401
CR4	Diode, MPN3401	1281-0050	Motorola	MPN3401
CR5	Diode, MPN3401	1281-0050	Motorola	MPN3401
CR6	Diode, MPN3401	1281-0050	Motorola	MPN3401
CR7	Diode, MPN3401	1281-0050	Motorola	MPN3401
CR8	Diode, MPN3401	1281-0050	Motorola	MPN3401
CR9	Diode, Microwave Pin 1SV34	1281-0075	Nippon Elec	1SV34
CR10	Diode, Microwave Pin 1SV34	1281-0075	Nippon Elec	1SV34
CR11	Diode, Microwave Pin 1SV34	1281-0075	Nippon Elec	1SV34
CR12	Diode, Microwave Pin 1SV34	1281-0075	Nippon Elec	1SV34
CR13	Not Used			
CR14	Diode, 1N3064	1281-0013	Teledyne	1N3064
CR15	Diode, 1N3064	1281-0013	Teledyne	1N3064

OUTPUT ATTENUATOR. A20 (cont)

CKT. REF.	DESCRIPTION	CE STOCK NO.	MFR.	MFR. NO.
CR16	Diode, HPA2800	1283-0001	HPA	5082-2800
	FUSE			
F1	Fuse, 1/32 Amp/125 V Plug-in	1955-0022	Littelfuse	273.031
	INDUCTORS			
L1	Assy, Coil Air Core	1596-0076	Cushman	
L2	Assy, Coil Air Core	1596-0076	Cushman	
L3	Choke, 2 1/2 Turns Wide Band	1586-0003	VK	20020/4B
L4	Choke, 100 μ H, 5%	1585-0017	Delevan	1537-76
L5	Choke, 2 1/2 Turns Wide Band	1586-0003	VK	20020/4B
L6	Choke, 100 μ H, 5%	1585-0017	Delevan	1537-76
L7	Choke, 2 1/2 Turns Wide Band	1586-0003	VK	20020/4B
L8	Choke, 100 μ H, 5%	1585-0017	Delevan	1537-76
	TRANSISTORS			
Q1	Trans, 2N3904	1272-0032	Motorola	2N3904
Q2	Trans, 2N3904	1272-0032	Motorola	2N3904
Q3	Trans, 2N3904	1272-0032	Motorola	2N3904
Q4	Trans, 2N3904	1272-0032	Motorola	2N3904
Q5	Trans, 2N3904	1272-0032	Motorola	2N3904
	RESISTORS			
R1	Res, 3.3K, 5%, 1/4W Comp	1066-3325	Allen-Bradley	CB3325
R2	Res, 3.3K, 5%, 1/4W Comp	1066-3325	Allen-Bradley	CB3325
R3	Res, 1.8K, 5%, 1/4W Comp	1066-1825	Allen-Bradley	CB1825
R4	Res, 61.9 Ohm, 1%, 1/10W MF	1075-0007	Dale	MF 1/10
R5	Res, 255 Ohm, 1%, 1/8W MF	1075-0047	Dale	MF 1/8
R6	Res, 61.9 Ohm, 1%, 1/10W MF	1075-0007	Dale	MF 1/10
R7	Res, 3.3K, 5%, 1/4W Comp	1066-3325	Allen-Bradley	CB3325
R8	Res, 3.3K, 5%, 1/4W Comp	1066-3325	Allen-Bradley	CB3325
R9	Res, 3.3K, 5%, 1/4W Comp	1066-3325	Allen-Bradley	CB3325
R10	Res, 3.3K, 5%, 1/4W Comp	1066-3325	Allen-Bradley	CB3325
R11	Res, 1.8K, 5%, 1/4W Comp	1066-1825	Allen-Bradley	CB1825
R12	Res, 61.9 Ohm, 1%, 1/10W MF	1075-0007	Dale	MF 1/10
R13	Res, 255 Ohm, 1%, 1/8W MF	1075-0047	Dale	MF 1/8
R14	Res, 61.9 Ohm, 1%, 1/10W MF	1075-0007	Dale	MF 1/10
R15	Res, 3.3K, 5%, 1/4W Comp	1066-3325	Allen-Bradley	CB3325
R16	Res, 3.3K, 5%, 1/4W Comp	1066-3325	Allen-Bradley	CB3325
R17	Res, 150 Ohm, 5%, 1/4W Comp	1066-1515	Allen-Bradley	CB1515
R18	Res, 24 Ohm, 5%, 1/4W Comp	1066-2405	Allen-Bradley	CB2405
R19	Res, 150 Ohm, 5%, 1/4W Comp	1066-1515	Allen-Bradley	CB1515
R20	Res, 150 Ohm, 5%, 1/4W Comp	1066-1515	Allen-Bradley	CB1515
R21	Res, 36 Ohm, 5%, 1/4W Comp	1066-3605	Allen-Bradley	CB3605
R22	Res, 150 Ohm, 5%, 1/4W Comp	1066-1515	Allen-Bradley	CB1515
R23	Res, 82 Ohm, 5%, 1/4W Comp	1066-8205	Allen-Bradley	CB8205
R24	Res, 33 Ohm, 5%, 1/4W Comp	1066-3305	Allen-Bradley	CB3305
R25	Res, 82 Ohm, 5%, 1/4W Comp	1066-8205	Allen-Bradley	CB8205

OUTPUT ATTENUATOR. A20 (cont)

CKT. REF.	DESCRIPTION	CE STOCK NO.	MFR.	MFR. NO.
R26	Res, 1.2K, 5%, 1/4W Comp	1066-1225	Allen-Bradley	CB1225
R27	Res, 100 Ohm, 5%, 1/4W Comp	1066-1015	Allen-Bradley	CB1015
R28	Res, 1K, 5%, 1/4W Comp	1066-1025	Allen-Bradley	CB1025
R29	Res, 1.6K, 5%, 1/4W Comp	1066-1625	Allen-Bradley	CB1625
R30	Res, 100 Ohm, 5%, 1/4W Comp	1066-1015	Allen-Bradley	CB1015
R31	Not Used			
R32	Res, 15K, 5%, 1/4W Comp	1066-1535	Allen-Bradley	CB1535
R33	Res, 3.3K, 5%, 1/4W Comp	1066-3325	Allen-Bradley	CB3325
R34	Pot, 20K, 20%, 1/2W	1203-0055	Bourns	3339H-1-203
R35	Res, 4.3K, 5%, 1/4W Comp	1066-4325	Allen-Bradley	CB4325
R36	Res, 15K, 5%, 1/4W Comp	1066-1535	Allen-Bradley	CB1535
R37	Pot, 10K, 20%, 1/2W 4 Turn	1203-0061	Bourns	3339H-1-103
R38	Res, 1K, 5%, 1/4W Comp	1066-1025	Allen-Bradley	CB1025
R39	Res, 2K, 5%, 1/4W Comp	1066-2025	Allen-Bradley	CB2025
R40	Res, 15K, 5%, 1/4W Comp	1066-1535	Allen-Bradley	CB1535
R41	Res, 100 Ohm, 5%, 1/4W Comp	1066-1015	Allen-Bradley	CB1015
R42	Res, 10K, 5%, 1/4W Comp	1066-1035	Allen-Bradley	CB1035
R43	Res, 5.1K, 5%, 1/4W Comp	1066-5125	Allen-Bradley	CB5125
R44	Pot, 20K, 20%, 1/2W	1203-0055	Bourns	3339H-1-203
R45	Res, 100 Ohm, 5%, 1/4W Comp	1066-1015	Allen-Bradley	CB1015
R46	Res, 10K, 5%, 1/4W Comp	1066-1035	Allen-Bradley	CB1035
R47	Pot, 50K, 20%, 1/2W	1203-0059	Bourns	3339H-1-503
R48	Res, 1K, 5%, 1/4W Comp	1066-1025	Allen-Bradley	CB1025
R49	Pot, 10K, 20%, 1/2W 4 Turn	1203-0061	Bourns	3339H-1-103
R50	Res, 4.3K, 5%, 1/4W Comp	1066-4325	Allen-Bradley	CB4325
R51	Pot, 10K, 20%, 1/2W 4 Turn	1203-0061	Bourns	3339H-1-103
R52	Res, 10K, 5%, 1/4W Comp	1066-1035	Allen-Bradley	CB1035
R53	Res, 1K, 5%, 1/4W Comp	1066-1025	Allen-Bradley	CB1025
R54	Res, 4.3K, 5%, 1/4W Comp	1066-4325	Allen-Bradley	CB4325
R55	Pot, 10K, 20%, 1/2W 4 Turn	1203-0061	Bourns	3339H-1-103
R56	Res, 15K, 5%, 1/4W Comp	1066-1535	Allen-Bradley	CB1535
	INTEGRATED CIRCUITS			
U1	IC, ATF419-16 dB Gain	2025-0064	Amperex	ATF419
U2	IC, SN72741P	2025-0067	T.I.	SN72741P
	FUSE HOLDER			
XF1	Fuse Holder, Vert PCB Mtg Submin	1965-0014	Littelfuse	281005

Figure 6-25a. Output Attenuator. A20

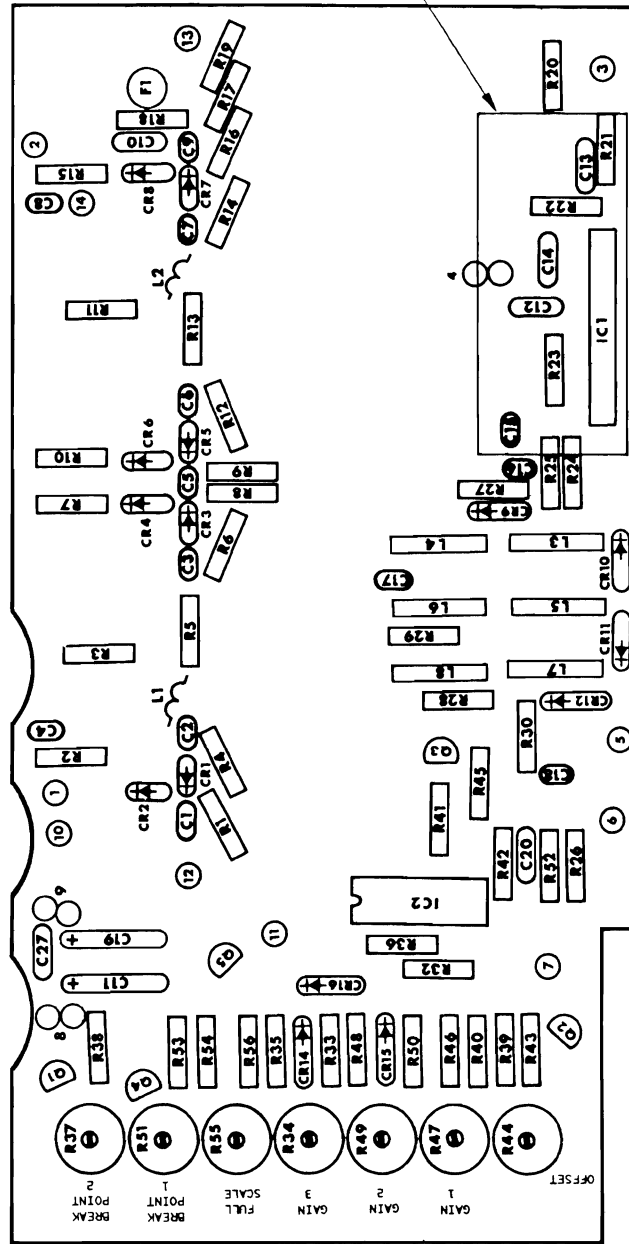

SHIELDED COMPONENT

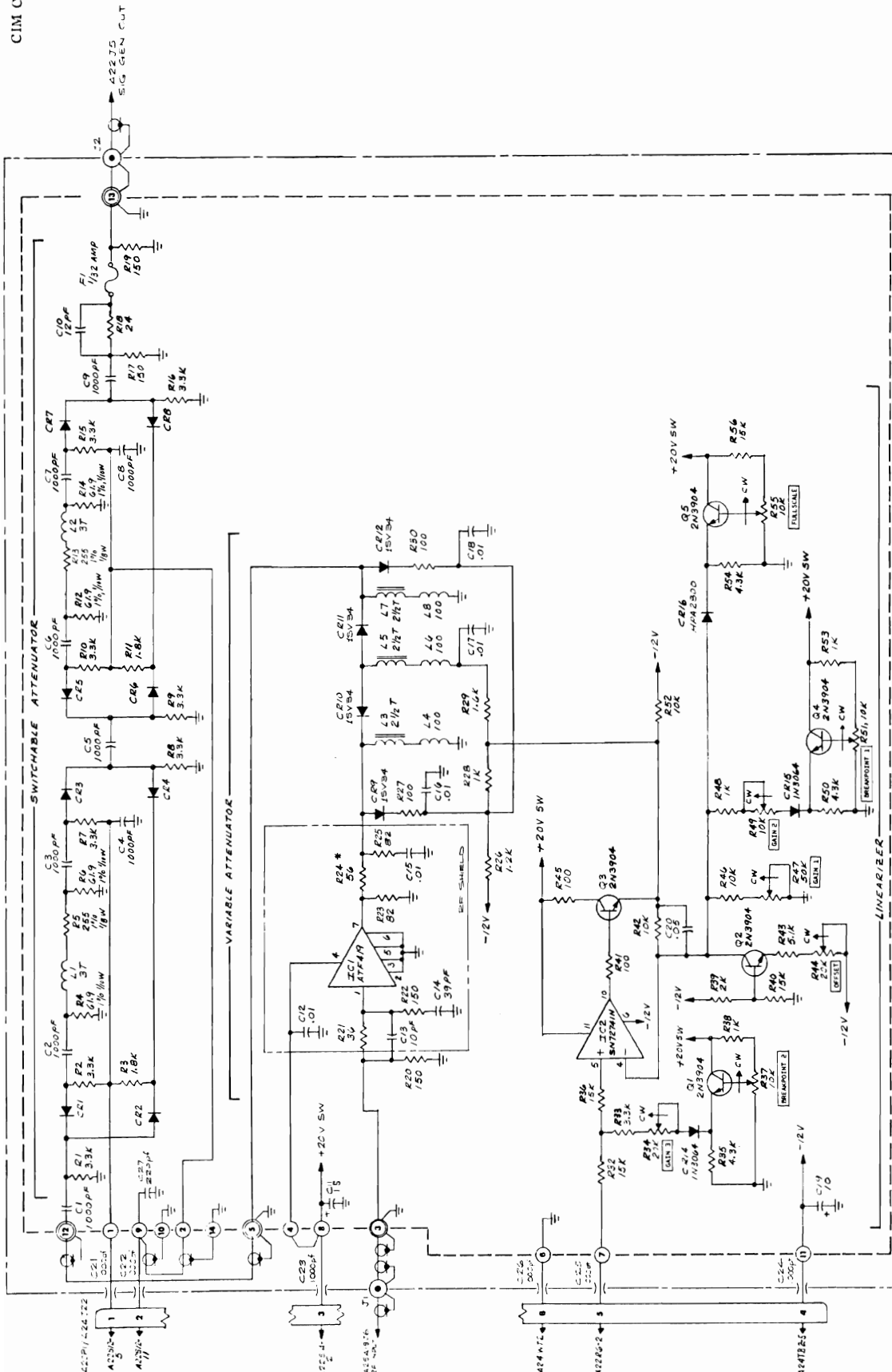

R31 f CR15 NOT USED

IC1
IC2
ATF419

BOTTOM VIEW

- NOTE:
1. MULTIPLIER - 10ⁿ VALUES IN OHMS UNLESS OTHERWISE NOTED.
 2. CAPACITORS - VALUES IN PF UNLESS OTHERWISE NOTED.
 3. RESISTORS - VALUES IN OHMS UNLESS OTHERWISE NOTED.
 4. TYPICAL VALUES SHOWN.
 5. ALL VOLTAGES WRT GND UNLESS OTHERWISE NOTED.
 6. ALL DIODES ARE 1N4148 UNLESS OTHERWISE NOTED.

Figure 6-25. Output Attenuator, A20

CUSHMAN INSTRUMENT WARRANTY

All instruments manufactured by Cushman Electronics, Inc. are warranted against defects in material and workmanship for a period of one year from the date of original shipment. Cushman will repair or replace instruments, which prove to be defective, in accordance with the following policy. This policy does not apply to repair service, parts sales, nor does it apply to instruments, or parts of the instrument, which in the opinion of Cushman, have been altered or misused.

All Countries

- During the first three months after the date of original shipment, no charge for parts, replacement PC boards, labor, or freight for instruments serviced at an authorized Cushman Service Center. Free freight applies only within the customer's country. Method of transportation shall be designated by an authorized Cushman representative or Service Center.
- During the fourth through the twelfth month after the date of original shipment, no charge for parts, replacement PC boards, and labor for instruments serviced at an authorized Cushman Service Center. All transportation charges for instruments, parts, or replacement PC boards shall be paid by the customer during this period.
- Replacement PC boards during the first year are warranted only when the defective boards have been identified by an authorized Cushman Service Center and the defective PC board is returned in accordance with Cushman's exchange board policy.

U.S.A. and Canada

In the U.S.A. and Canada an additional two year limited warranty is offered extending from the 13th until the 36th month from the date of original shipment. This warranty is effective beginning with instruments purchased on or after April 1, 1977. During this period, the following limited warranty policy applies:

- No charge for parts* used by an authorized Cushman Service Center to repair an instrument.
- Cushman will replace at no charge, PC boards which are found to be defective by an authorized Cushman Service Center. Defective boards must be returned to Cushman in accordance with Cushman's PC board exchange policy.
- All transportation charges for instruments, parts, and replacement PC boards shall be paid by the customer during this period.

* Cathode ray tubes and batteries excluded.



TABLE OF CONTENTS

		page
SECTION 1	GENERAL	
	Introduction	1-1
	General Description	1-1
	Accessories	1-2
SECTION 2	INSTALLATION	
	Unpacking and Inspection	2-1
	Environmental Requirements	2-1
	Power Requirements	2-1
	Warm-up Requirements	2-1
	Preparation for Reshipment	2-1
	Service or Repair	2-3
SECTION 3	OPERATION	
	General Information	3-1
	Front Panel Controls	3-1
	Turn On and Warm Up	3-1
	Frequency Deviation Measurement	3-1
	AM/CW, FM Signal Generation	3-4
	Audio and IF Signal Generation	3-5
	Out of Band Operation	3-5
	Dial Indicator Light Replacement	3-6
SECTION 4	THEORY OF OPERATION	
	Introduction	4-1
	Functional Description	4-1
	Frequency Synthesizer	4-1
	Circuit Description	4-4
	Master Oscillator, Divider and Filters. A6	4-4
	Reference Divider/Phase Detector. A3	4-4
	6-10 MHz VCO. A2	4-5
	Divide-by-N Counter. A14	4-5
	40 MHz, 43 MHz and 46 MHz Filters. A11	4-7
	42 MHz Filter, Audio Amplifier, Mixer and IF Switching. A16	4-7
	Balanced Mixer. A8	4-7
	46-50.99 MHz X10 Multiplier. A9	4-8
	43 MHz X10 Multiplier. A10	4-8
	Programmable Phase Lock Loop and Amplifier. A17	4-8
	RF Mixers and IF Amplifiers. A19	4-9
	Switching Logic. A15	4-9
	1 kHz-to-4 MHz Mixer and 9.9 MHz Filter. A7	4-10
	Second IF/Discriminator and Frequency Error Meter. A5, A4	4-10
	Second Mixer	4-10
	Frequency Error Detector	4-10
	Audio Circuits	4-12
	Signal Level Detector	4-12
	Signal Generating Circuits	4-12
	10 MHz Modulator. A18	4-12
	Output Attenuator. A20	4-14
	Power Supplies	4-14
	Decimal Point Lights and Flasher. A22	4-14

	page
SECTION 5	MAINTENANCE
General Information	5-1
Access and Parts Location	5-1
Adjustments	
Power Supply Voltages	5-2
Master Oscillator Frequency	5-2
Frequency Meter Zero Adjust	5-2
Modulator Center Frequency	5-2
Frequency Meter Range	5-2
20 dB Fixed Attenuator	5-3
Signal Generator Output Level	5-3
Troubleshooting	5-4

SECTION 6	PARTS LISTS AND SCHEMATIC DIAGRAMS	
Introduction		6-1

ILLUSTRATIONS

Figure No.

1-1	CE-5 Communications Monitor	viii
2-1	Auxiliary Items Furnished with CE-5	2-2
4-1	Frequency Synthesizer, Simplified Block Diagram	4-3
4-2	Divide-by-N Counter, Simplified Block Diagram	4-6
4-3	Second IF and Discriminator Circuits, Simplified Block Diagram	4-11
4-4	Frequency Meter Bridge Circuit	4-12
4-5	Model CE-5 Overall Block Diagram	4-15
5-1	Circuit Board Location	5-1
6-1	6-10 MHz VCO. A2	6-5
6-2	Reference Divider/Phase Detector. A3	6-9
6-3	Frequency Error Meter. A4	6-13
6-4	Second IF/Discriminator. A5	6-19
6-5	Master Oscillator/Divider/Filters. A6	6-25
6-6	1kHz-4kHz Mixer/9.9 MHz Filter. A7	6-29
6-7	46.00-50.99 MHz Balanced Mixer. A8	6-35
6-8	46.00-50.99 MHz X10 Multiplier. A9	6-39
6-9	43 MHz X10 Multiplier. A10	6-43
6-10	40 MHz, 43 MHz, and 46 MHz Filter. A11	6-49
6-11	Power Supply Regulator. A12	6-53
6-12	Power Supply Rectifier. A13	6-57
6-13	Divide-by-N. A14	6-61
6-14	Switching Logic. A15	6-65
6-15	42 MHz Filter, Audio Amplifier, Mixer and IF Switching. A16	6-71
6-16	Programmable Phase Lock Loop and Amplifier. A17	6-77
6-17	10 MHz Modulator. A18	6-83
6-18	RF Mixers and IF Amplifier. A19	6-91
6-19	Interconnection Diagram, Front Panel, Sheet 1. A22	6-95
6-20	Interconnection Diagram, Front Panel, Sheet 2. A22	6-97
6-21	Wiring Diagram, Rear Panel. A23	6-101
6-22	Interconnection Diagram, Main Chassis. A24	6-105
6-23	Interconnection Diagram, Center Plate. A25	6-109
6-24	20 dB Pad Assembly	6-113
6-25	Output Attenuator. A20	6-119

TABLES

Table No.		page
1-1	Specifications	1-3
2-1	Auxiliary Items Furnished with CE-5	2-2
3-1	Operating Controls and Connectors	3-2
3-2	Synthesizer Frequency Relationships	3-6
4-1	Synthesizer Frequency Relationships and Mixer Plan	4-2
4-2	Frequency Relationships, Audio and IF Signal Generation	4-4
4-3	6-10 MHz VCO Tank Circuits Selected by First and Second Frequency Selectors	4-5
4-4	Decimal Count of a Decade and the Binary States of the Flip-Flops	4-5
4-5	Fifth Decade Count Preset by First and Second Frequency Selectors	4-7
4-6	Programmable Phase Lock Loop Switching	4-8
4-7	Mixer and IF Amplifier Switching	4-9
5-1	Troubleshooting Chart	5-5
6-1	Printed Circuit Board and Circuit Reference Numbers Cross Reference	6-1

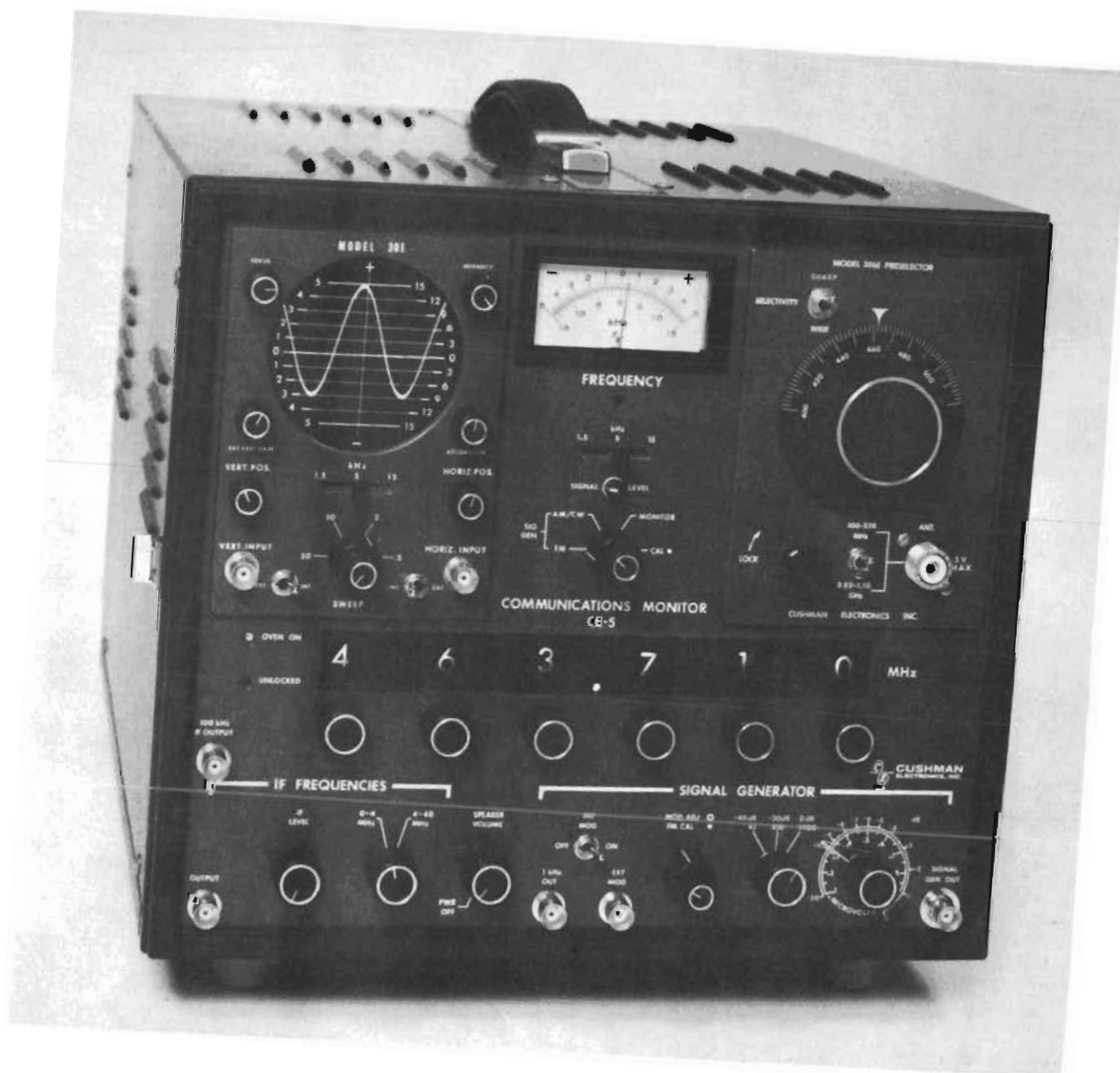

Figure 1-1. CE-5 Communications Monitor

SECTION 1

GENERAL

INTRODUCTION

1.01 The Cushman CE-5 Communications monitor accurately measures the frequency of the output of FM or AM transmitters. The range of measurement is from 20 MHz to 519.999 MHz. It also measures the frequency deviation of the modulated output of these transmitters, and using the Model 313 plug-in the percentage of AM may be measured.

1.02 The CE-5 functions as a signal generator covering the same range of 20 MHz to 519.999 MHz with the same accuracy as in the Monitor mode. The output level is calibrated from 0.1 to 100 microvolts. The output may be either FM, AM or CW and the modulation and level are both adjustable. Modulation, both FM and AM, is from an internal 1 kHz source. Modulation from an external source, 60 Hz to 20 kHz, may also be used for both AM and FM. In addition both internal and external modulation may be applied simultaneously.

1.03 In the IF Frequencies mode signals from 1 kHz to 40 MHz are available at a separate output, with the same accuracy as the generator. Level is adjustable but not calibrated. These IF Frequencies may be used for alignment and troubleshooting of receiver IF and audio circuits.

1.04 In the generator mode the CE-5 may be used to align and check the sensitivity of receivers. Since both internal and external modulation may be used simultaneously or several external modulating frequencies may be summed and used to modulate the output, the instrument may be used for testing and aligning of tone operated receivers.

1.05 When a measurement of the received frequency with greater resolution is required a counter may be connected to the 100 kHz IF OUTPUT connector. This output is 100 kHz \pm the error of the signal with reference to the dialed in frequency. The accuracy now will be the accuracy of the CE-5 Master Oscillator crystal frequency \pm the accuracy of the counter.

GENERAL DESCRIPTION

1.06 The CE-5 is a specialized VHF/UHF super-heterodyne receiver. With it a transmitter can be monitored for correct carrier frequency and amount of modulation deviation. The assigned transmitter carrier frequency is "dialed in" and the actual carrier frequency of the received signal is compared with an internally generated standard. This standard is the local-oscillator (LO) frequency.

1.07 When the incoming signal is of sufficient amplitude, a frequency error detector is activated and a meter shows the difference between the assigned carrier frequency and the actual carrier frequency. Discriminator circuits are also turned on which provide an indication (on a Deviation Meter or Oscilloscope) of frequency deviation.

1.08 The CE-5 must be operated with either a Cushman Model 301 Oscilloscope or a Model 302 Deviation Meter inserted into the left-hand plug-in compartment, and the broadband mixer, one of the RF Preselectors or one of the other available plug-ins in the right hand compartment.

1.09 The incoming signal is received at the antenna connector of whatever RF plug-in is used and a first intermediate frequency (IF) signal is produced with a frequency that is 10 MHz \pm carrier frequency error. LO frequency = dialed in frequency \pm 10 MHz. Dialed in frequency = assigned carrier frequency, therefore the difference between the LO frequency and the actual carrier frequency is 10 MHz \pm the carrier frequency error. The LO frequency may be either 10 MHz above or below the dialed in frequency.

1.10 The first IF signal is mixed with a stable 9.9 MHz signal from the Master Oscillator (MO) to produce a second IF signal with a frequency of 100 kHz \pm carrier frequency error. The error is detected and displayed on the FREQUENCY meter.

1.11 The second IF signal is also demodulated and the resultant audio frequency signal is amplified in the Deviation Meter or in the Oscilloscope to give an indication of the amount of FM deviation present due to the modulation on the received carrier.

1.12 In the Signal Generator mode the LO is used for the output signal, but is shifted \pm 10 MHz so that the output frequency will be the same as the dialed in frequency. This 10 MHz shift is automatically taken care of by mixing an internally generated 10 MHz signal with the LO. This 10 MHz signal can be modulated, either FM or AM, or left unmodulated for CW output. Modulation is by an internally generated 1 kHz signal or may be from an external source, or both may be used together.

1.13 The level of FM, AM or CW signals generated by the CE-5 is controlled by attenuators which are calibrated to give an output of between 0.1 and 100 microvolts through a 20 dB fixed attenuator which is supplied with the instrument. This fixed attenuator should be used for protection, but approximately 10 times more signal is available

without the pad. A fuse is included in the signal generator and in the 20 dB pad to protect the signal generator mixer from accidental overload.

1.14 IF Frequencies are also available for external use. This output is a signal variable throughout the audio range and throughout the range of frequencies that are usually found in the intermediate frequency stages of commercial radio receivers (that is, a range of from 1 kHz to 40 MHz). The IF frequency output level is not calibrated. From 0 to 3.9999 MHz the frequencies are fundamentals, from 4 to 39.999 MHz the harmonic content is enhanced and the 10th harmonic of the fundamentals is used. Other harmonics are also present in this signal and are available for use. Connection to the output is made at the IF output connector. The first dial digit must be placed in the IF position to obtain these frequencies.

1.15 The numbers that indicate the dialed-in frequency are operative in all modes of the CE-5, monitoring as well as signal generating. The numbers are lighted for easy reading. If a frequency that is not within the operating range of the CE-5 is selected, the display will flash on and off to indicate this. Table 1-1 lists the specifications for the CE-5 as well as the pertinent characteristics of the available plug-in accessories.

ACCESSORIES

1.16 Two types of accessories are available for use with the CE-5. Units that plug into the Monitor and obtain operating power from it, and items furnished with the Monitor but not integral parts of it.

1.17 Plug-In Units

1.18 An opening in the left-hand part of the Monitor front panel, accepts either the Model 301 Oscilloscope or the Model 302 FM Deviation Meter. One or the other of these must be used to provide FM deviation measurements. A similar opening in the right-hand part of the front panel accepts a Model 303 Broadband Mixer, a Model 313 AM Monitor, or one of the presently available RF Preselectors.

1.19 The Model 303 Broadband Mixer is used in the measurement of frequency and FM deviation of local transmitters over the whole range of 20-520 MHz. The RF Preselectors are used over the ranges of the most used bands in the same way for monitoring transmitters many miles

distant. The Preselectors are also equipped with broadband mixers. The Model 312 Frequency Extender covers the range of 50 kHz to 20 MHz for both FM measuring and the Signal Generating functions. The Model 313 has all the capabilities of the Model 303 and in addition it can monitor AM signals. It displays the percentage of AM (0-100%) in either the Monitor or Signal Generator modes.

1.20 The Model 301 Oscilloscope permits visual examination of the exact modulation of the transmitter carrier. Unbalanced modulation, power supply pulses, unusual clipping, and other problems are immediately apparent so that appropriate repairs can be made. The Model 301 has an automatic sync circuit similar to that found in laboratory instruments. The scope graticule is calibrated to show deviation on any one of three ranges: ± 1.5 , ± 5 , and ± 15 kHz. Switches on the front panel permit use of external vertical inputs while using the internal sweep. External signals may also be connected to the horizontal input. This permits use of the Model 301 independently of the monitoring function, for routine testing, troubleshooting, displaying Lissajous patterns, etc. The Oscilloscope can also be used for receiver IF bandwidth measurement and discriminator alignment, as described in the Model 301 manual.

1.21 The Model 302 FM Deviation Meter provides three ranges: 0 to 2.5, 0 to 6, and 0 to 25 kHz. An instantaneous peak indicator light flashes when the absolute peak deviation of the incoming carrier exceeds an amount preset by means of the SET control. Operation and accuracy of the flasher are not affected by modulation frequency, repetition rate, or waveform. A switch permits selection and measurement of either plus (+) or minus (-) deviation peaks. A scope jack is provided for simultaneous meter indications and oscilloscope observations of deviation (a separate oscilloscope, not a Model 301, must be used).

1.22 Auxiliary Items

1.23 Two major auxiliary items are supplied with the instrument: a telescoping antenna, extendable from 9.5 to 39 inches, and a 20 dB fixed attenuator with cable for use with the CE-5 when a generated signal is being fed into a receiver. (See Table 2-1 for a complete list of auxiliary items). Both the attenuator and the cable are stored inside the front cover of the instrument. Installation of the antenna is described in Section 3.10a, the use of the 20 dB fixed attenuator in Section 3.11d.

Table 1-1. CE-5 Communications Monitor, Specifications

ITEM	CHARACTERISTICS
RF SIGNAL GENERATION	
FREQUENCY	
Range	20-519.999 MHz
Resolution	1000 Hz
Accuracy	0.00003% ± Time Base
LEVEL	
Range	0.1μV to 100μV RMS, after external 20 dB attenuator
Accuracy	±3 dB at 100μV RMS output from external 20 dB attenuator
Dial Attenuator	±2 dB
Step Attenuator	±2 dB
OUTPUT IMPEDANCE	50Ω Nominal
MODULATION	
FM	
Internal	
Frequency	1000 Hz
Deviation	0 to 25 kHz min.
Distortion, Deviation in the range of 3.3 to 15.0 kHz	2% max.
External	
Frequency	100 Hz to 20 kHz
(For optimum performance the sum of the modulating frequency and deviation, in kHz, should not exceed 45)	
Input Impedance	600Ω nominal
Simultaneous	
Frequency	External tone 100 Hz to 20 kHz, and internal tone 1000 Hz
AM	
Internal	
Frequency	1000 Hz
Range	0 to 80% min.
Distortion	5% max.
30% modulation	10% max.
80% modulation	10% max.
External	
Frequency	100 Hz to 20 kHz
MONITOR	
Frequency	
Range	20-519.999 MHz
Resolution	50 Hz
Meter	0.00003% ± Time Base
Accuracy	See plug-in specifications
Sensitivity	
IF SIGNAL GENERATION	
Frequency	
Range	1 kHz-3.9999 MHz
Accuracy	4 MHz-39.999 MHz (on harmonics)
Accuracy	0.00003% ± Time Base

ITEM	CHARACTERISTICS
<p>Level</p> <p>100 kHz I. F. Output Level</p> <p>1 kHz Output Level Distortion</p> <p>TIME BASE</p> <p>Aging</p> <p>Oven Warm-up Time</p> <p>POWER REQUIREMENTS</p> <p>DIMENSIONS</p> <p>WEIGHT</p> <p>Less Plug-ins With Plug-ins</p> <p>ENVIRONMENTAL</p> <p>Temperature, operating Temperature, storage Humidity Vibration Shock Altitude</p> <p>BRIEF PLUG-IN SPECIFICATIONS</p>	<p>0 to 1 volt nominal into 600Ω in 0-4 MHz mode 5 volt nominal into 600Ω in 4-40 MHz mode</p> <p>100mV RMS min. into 10kΩ min. load impedance</p> <p>1V p-p nominal into 600Ω ≤2%</p> <p>5 x 10⁻⁸/Month max. (3 month average) 6 x 10⁻⁷/Year max.</p> <p>Less than 25 min. from 25°C to 3 x 10⁻⁷ Less than 45 min. from 0°C to 3 x 10⁻⁷</p> <p>115V ±10% AC, 50-400 Hz, 75 Watts max. (Factory option available for 230V ±10% AC, 50-400 Hz.)</p> <p>12 1/4" High x 13" Wide x 18 1/2" Deep</p> <p>31 lbs. (Approx.) 38 lbs. (Approx.)</p> <p>0°C to 55°C -40°C to +75°C 95% RH, +40°C 10-55 CPS, .01" p-p amplitude 4" Bench drop 25,000 Ft. Non-operative 15,000 Ft. Operative</p>
<p>Model 301A Oscilloscope Plug-in</p> <p>Deviation Measurement Accuracy</p> <p>External Inputs</p> <p>External Vertical Sensitivity</p> <p>External Frequency Response (3 dB)</p>	<p>±5% full scale in three ranges: ±1.5 kHz, 5.0 kHz, 15.0 kHz</p> <p>Vertical and Horizontal 5mV, 20mV, 100mV per division ±5% 100 kHz</p>
<p>Model 302 Deviation Meter Plug-in</p> <p>Accuracy of Measurements</p>	<p>±4% full scale in three ranges: 0-2.5, 0-6, 0-25 kHz</p>
<p>Model 303 Broadband Mixer Plug-in</p> <p>Frequency Coverage</p> <p>Nominal Input Impedance</p> <p>Bandwidth (3 dB)</p> <p>Broad Narrow</p> <p>Sensitivity: Less than</p>	<p>20-1000 MHz 50 ohms</p> <p>75 kHz 13.5 kHz</p> <p>10mV</p>

ITEM	CHARACTERISTICS	
RF Preselector Plug-ins Frequency Coverage Nominal Input Impedance Bandwidth (3 dB) Broad Narrow Sensitivity: Less than	Model 304B	Model 315C
	25-50 MHz 50 ohms	40-90 MHz 50 ohms
	65 kHz 20 kHz	65 kHz 20 kHz
	20 microvolts	20 microvolts
Frequency Coverage Nominal Input Impedance Bandwidth (3 dB) Broad Narrow Sensitivity: Less than	Model 307B	Model 305B
	120-139.9999 MHz 50 ohms	140-175 MHz 50 ohms
	65 kHz 20 kHz	65 kHz 20 kHz
	20 microvolts	20 microvolts
Frequency Coverage Nominal Input Impedance Bandwidth (3 dB) Broad Narrow Sensitivity: Less than	Model 306E	Model 314 High Sensitivity Mixer
	450-520 MHz 50 ohms	20-1000 MHz 50 ohms
	65 kHz 20 kHz	75 kHz 22 kHz
	20 microvolts	1 microvolt
Model 313 AM Monitor Frequency Coverage AM Modulation (Meter) Range Nominal Input Impedance Bandwidth (3 dB) Broad Narrow Sensitivity 50-90 MHz 950-1000 MHz 20-50 MHz with CE-5, CE-6 20-50 MHz with CE-3, CE-7	20-1000 MHz 0-100% 50 ohms 100 kHz 22 kHz 10 mV 20 mV 10 mV 50 mV	
Model 330 Wattmeter/Duplexer Tester Wattmeter/Duplexer Tester Frequency Coverage Power Range Accuracy Broadband Section Frequency Coverage Nominal Input Impedance Bandwidth Broad Narrow Sensitivity: Less than	20-1000 MHz 1-25 watts ±4% reading plus 1% full scale 20-1000 MHz 50 ohms 100 kHz 22 kHz 10 mV	

SECTION 2

INSTALLATION

UNPACKING AND INSPECTION

2.01 When unpacking the Model CE-5 Communications Monitor inspect the packing box and the instrument for signs of possible shipping damage and see if the auxiliary items, listed in Table 2-1 and shown in Figure 2-1, are present. Verify satisfactory performance as outlined in the Operating Instructions (Section 3). If the instrument is damaged or fails to operate properly, or if any of the auxiliary items are missing, file a claim with the transportation agency or, if insured separately, with the insurance company.

ENVIRONMENTAL REQUIREMENTS

2.02 Temperature

2.03 The CE-5 is designed to operate between 0°C and +55°C (ambient). Especially in the field, these temperatures can easily be exceeded; for instance, the internal temperature of a closed automobile trunk may exceed 150°C during summer daylight hours.

Do not block the cabinet ventilating louvers. Exceeding the upper or lower temperature limits for extended periods may not result in noticeable damage to the instrument, but may cause poor performance or actual malfunctioning.

2.04 RF Fields

2.05 Where extremely high RF radiation fields exist (such as when the CE-5 is used near a transmitter), the telescoping antenna should be pushed down to reduce pickup. Where many high-power transmitters are in use adjacent-channel interference may be experienced if the transmitters are operating within 90 kHz of each other. In such cases, the SELECTIVITY switch on the Model 303 Broadband Mixer should be placed in the SHARP position. If satisfactory measurements can still not be made, direct connection between the transmitter to be monitored and the CE-5 via an RF attenuator may be required; contact Cushman Electronics for further information. (Note: In the SHARP position the bandwidth is narrowed so that deviation readings may be degraded unless the sum of the modulation frequency plus the frequency deviation, in kHz, is less than 11. In the WIDE position this sum may be as much as 33.)

POWER REQUIREMENTS

2.06 The CE-5 operates from a 115 volt ($\pm 10\%$) 50 to 400 Hz AC source. Power consump-

tion is 75 watts. If 230V AC operation is desired this must be specified in the original order. A 115 volt instrument may be converted to 230V AC by returning to the factory for the installation of a 230 volt crystal oven and the necessary wiring changes.

WARM-UP REQUIREMENTS

2.07 The accuracy of CE-5 measurements depends on maintaining the master-oscillator crystal at a constant temperature. This is done by a thermostatically controlled oven which requires a 25 minute warm-up period prior to use. (When stored at temperatures down to 0°C, up to 45 minutes is required for warm-up. Proportionately more time is required for lower temperatures.) Oven operation is independent of the on-off power control and it is recommended that the instrument be installed so that it can be kept connected to its power source. Thus, the CE-5 will be ready to make precise measurements within seconds after the instrument is turned on.

PREPARATION FOR RESHIPMENT

2.08 It is recommended that the shipping box and foam packaging be kept in case it becomes necessary to ship the instrument to the service point or factory for service or repair. (Contact Cushman Electronics Customer Service Department before returning an instrument.)

2.09 The following is a general guide for repackaging the instrument for shipment.

NOTE

If the instrument is to be shipped, attach a tag to the instrument identifying the owner and showing the return address. Indicate the service or repair to be accomplished. Include the model number and full serial number on the instrument. In any correspondence, always identify the instrument by model number and serial number.

2.10 If the original container is to be used, proceed as follows:

(1) Place the instrument in the original container. (If the original container is not available, one can be purchased from Cushman Electronics.)

(2) Make sure that the container is well sealed with strong tape.

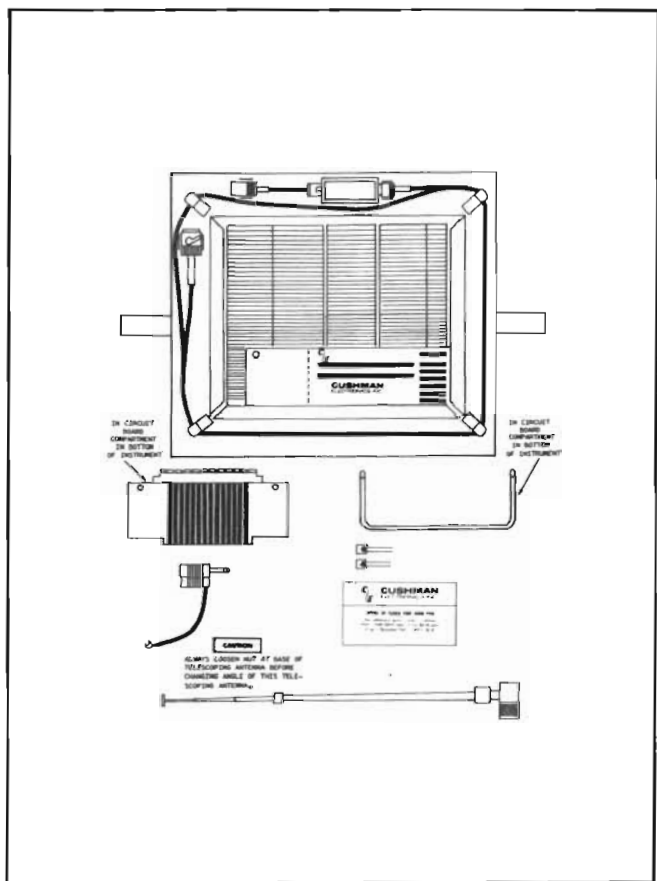

Figure 2-1. Auxiliary Items Furnished With CE-5

Table 2-1. Auxiliary Items Furnished with CE-5

ITEM	DESCRIPTION	CUSHMAN STOCK NO.	QUANTITY
1	Fuse, RF, 1/10 Amp	1955-0032	2
2	Three prong/two prong AC Plug Adapter	2535-0001	1
3	Extractor, P. C. Board	3875-0036	1
4	Extender Board	7001-0140	1
5	20-dB Fixed Attenuator Adapter Cable Assembly	7040-0049	1
6	RF Cable Assembly	7032-5001-01	1
7	Antenna Assembly	7040-0019	1
8	Manual, CE-5	5601-0034	1
9	Front Cover	7005-0029	1

- 2.11 If the original container is not used, proceed as follows:
- (1) Wrap the instrument in plastic or heavy paper before placing in an inner container.
 - (2) Place packing material around all sides of the instrument.
 - (3) Place the instrument and inner container in a heavy carton or wooden box and seal with strong tape or metal bands.
 - (4) Mark the shipping container: "DELICATE ELECTRONIC INSTRUMENT", "FRAGILE".

SERVICE OR REPAIR

- 2.12 In the event that factory service or repair seems to be required, contact the Cushman Electronics Customer Service Department for further service information or to make arrangements for shipment to the factory or to a Service Center. The factory address is:

Cushman Electronics, Inc.
 Customer Service Department
 2450 N. First St.
 San Jose, California 95131
 Telephone: (408) 263-8100

- 2.13 Cushman Electronics repair service is also available at the following service centers:

Anderson Associates
 2225 Beltline Road
 Carrollton, Texas 75006
 Telephone: (214) 245-3912

B. C. S. Associates, Inc.
 940 North Fern Creek Avenue
 Orlando, Florida 32803
 Telephone: (305) 896-4881

B. C. S. Associates, Inc.
 1310 Beaman Place
 Greensboro, North Carolina 27408
 Telephone: (919) 273-1918

Ossman Instruments Service Corp.
 6666 Old Collamer Road
 East Syracuse, New York 13057
 Telephone: (315) 437-7245

Reshal Associate, Inc.
 219 West University Drive
 Arlington Heights, Illinois 60004
 Telephone: (312) 398-7660

SECTION 3 OPERATION

GENERAL INFORMATION

3.01 The Model CE-5 may be operated in one of three modes: Monitor (frequency and deviation measurement), AM/CW or FM Signal Generation, IF and Audio frequency generation. The first two modes are selected by the Function switch, located in the center of the panel. The third mode is selected by the most significant digit switch (farthest left) of the Frequency Selector switches, when it is in the IF position.

3.02 In the MONITOR position of the function switch, the incoming signal is applied through the ANT. connector, either from an outside antenna or from the telescoping antenna. The signal frequency is measured by dialing in the assigned frequency of the transmitter with the six frequency selectors and reading the frequency error on the FREQUENCY meter. Modulation deviation is indicated simultaneously by the FM DEVIATION meter of the Model 302 Deviation Meter or on the screen of the Model 301 Oscilloscope, whichever is used. A built-in speaker makes the modulation on the incoming carrier audible. Level is adjusted by the SPEAKER VOLUME control.

3.03 In the SIG. GEN. positions of the function switch, the desired frequency is also dialed in with the six Frequency Selector knobs. The generated signal (AM/CW or FM) is available at the SIGNAL GEN. OUT connector. A precision attenuator provides calibrated outputs of 0 to 1, 0 to 10, 0 to 100 microvolts. When SIG. GEN./FM has been selected (instead of AM/CW) the modulation deviation can be varied from zero to 25 kHz. An internally generated 1 kHz modulating signal is available or, an external modulating signal can be used, or both internal and external modulation may be used simultaneously. The amount of deviation of the modulation on this generated signal can be read on the FM DEVIATION meter or on the Oscilloscope screen. Level is adjusted with the MOD ADJ control.

3.04 In the AM/CW position the output is CW, if no modulating tone is applied. The internal 1 kHz source may be used to modulate the output or an external signal connected to the EXT MOD connector. Both internal and external modulation may be used simultaneously if desired. Level is adjusted with the MOD ADJ control.

3.05 When audio or IF signal generation is desired, the first and second (from the left) frequency selectors must be used. Turning the first knob brings into view the numbers 0-5, or the

letters IF. To prepare the instrument for audio or IF frequency signal generation, the first knob is turned until IF shows. Unless the second knob is turned to 0, 1, 2, or 3, the light which illuminates the six windows will flash on and off, indicating that the frequency dialed is not within the capability of the CE-5 to generate. If the first knob has been set to show IF and the IF FREQUENCIES switch is in the 0-4 MHz position, output frequencies from 1 kHz to 3.9999 MHz can be generated in 100 Hz increments and are selected by dialing the desired number. In the 4-40 MHz position of the IF FREQUENCIES switch, the decimal point appears between the third and fourth digits and harmonic frequencies up to 39.999 MHz are available in 1 kHz increments. The generated signal is available at the IF FREQUENCIES OUTPUT connector and the level is adjusted with the adjacent IF LEVEL control.

FRONT PANEL CONTROLS

3.06 The front panel controls, displays, and connectors shown in Figure 1-1 are listed in Table 3-1. The knob below the FREQUENCY meter, which is used to switch from signal measurement to signal generation is called the Function Switch in the table and throughout the text. The six knobs in a row just below the frequency display window are used to dial in a frequency. They are referred to as the Frequency Selectors. Operating controls for the plug-in units are described in the instruction books for those units.

TURN ON AND WARM UP

3.07 Plug the power cord into an AC power outlet (117 volts $\pm 10\%$, 50 to 400 Hz) and turn on the power by means of the on/off switch on the SPEAKER VOLUME control.

3.08 Allow the CE-5 to warm up for approximately 15 minutes. (If the instrument has been stored at a temperature below +32°F, additional warm-up time to bring instrument up to operating temperature is required).

FREQUENCY DEVIATION MEASUREMENT

3.09 In the following procedure it is assumed that the RF plug-in is either a Model 303 Broadband Mixer or one of the Preselectors operating in the Broadband mode. In the Preselector mode, the procedure is the same except that the Preselector dial must be set to the frequency dialed in on the CE-5. The Model 301 Oscilloscope or the Model 302 Deviation Meter must be plugged into the left hand opening of the CE-5.

Table 3-1. Operating Controls and Connectors

CONTROL OR CONNECTOR	FUNCTION
<p>FREQUENCY Meter</p> <p>kHz 1.5, 5, 15</p>	<p>Indicates received signal error, above or below the dialed in frequency, in kHz.</p> <p>Range switch for FREQUENCY meter. Indicates full scale ranges in MONITOR mode only. In SIG GEN FM range is ± 5 kHz only. In CAL or SIG GEN AM/CW RANGE IS ± 1.5 kHz only.</p>
<p>SIGNAL LEVEL Indicator Light</p>	<p>Lights when a received signal is strong enough for reliable measurements, in MONITOR mode. In other Function switch positions has no significance with regard to signal level.</p>
<p>Function Switch</p> <p>CAL</p> <p>MONITOR</p> <p>SIG GEN AM/CW</p> <p>SIG GEN FM</p>	<p>The FREQUENCY meter is zeroed with the inner knob of the Function switch. FREQUENCY meter range is automatically ± 1.5 kHz.</p> <p>Receive-Monitor operation. Both carrier frequency and FM deviation may be measured. With Model 313 plug-in AM percentage of modulation may be measured.</p> <p>Signal Generator operation. Output frequency is the same as the dialed in frequency. CW when neither internal nor external modulation is applied. AM with either internal or external modulating tones.</p> <p>Signal Generator operation. Output frequency the same as the dialed in frequency \pm the FREQUENCY meter reading on ± 5 kHz scale. Meter centered by FM CAL control.</p>
<p>OVEN ON Indicator Light</p>	<p>On whenever power is applied to the instrument.</p>
<p>UNLOCKED Indicator Light</p>	<p>Indicates an unlocked condition in the Frequency Synthesizer when lighted.</p>
<p>MHz, Frequency Selectors</p>	<p>Each frequency selector knob is associated with a lighted number indicating the dialed in frequency. Numbers will flash off and on if a frequency is dialed that is not within the range of the instrument.</p>
<p>100 kHz IF OUTPUT connector</p>	<p>100 kHz \pm error of signal being received or generated. For connection to a Frequency Counter to give greater resolution.</p>
<p>IF FREQUENCIES</p> <p>IF LEVEL</p> <p>0-4 MHz</p>	<p>First (left side) Frequency Selector dial must be set to IF to obtain these frequencies.</p> <p>Adjusts IF output level. Uncalibrated.</p> <p>Frequencies in the range of 1 kHz to 3.9999 MHz may be generated when the Frequency Selector switches (other than the first) are set to the desired frequency. Decimal point automatically positioned.</p>

Table 3-1. Operating Controls and Connectors (continued)

CONTROL OR CONNECTOR	FUNCTION
4-40 MHz	Frequencies in the range of 4-39.999 MHz may be generated when the Frequency Selector switches (other than the first) are set to the desired frequency. Decimal point automatically positioned. These are the tenth harmonic amplified output of the fundamentals of the lower range. Other harmonics are present and may be used.
OUTPUT connector	IF Frequencies available at this connector.
SPEAKER VOLUME/PWR OFF switch	Controls signal level to the internally mounted speaker. Controls AC power to the instrument. When in the OFF position the crystal oven only is supplied with power.
SIGNAL GENERATOR INT MOD/OFF ON	In the ON position 1 kHz modulating tone is supplied for internal FM or AM, when instrument is in SIG GEN mode.
EXT MOD Connector	External modulating signals, 60 Hz to 20 kHz, modulate the output whenever they are applied to this connector in the SIG GEN mode.
1 kHz OUT Connector	The internally generated 1 kHz modulating tone always available at this connector.
MOD ADJ	Adjusts Frequency Deviation in FM mode or percentage of modulation in AM mode. Frequency deviation is measured on the Deviation Meter or Oscilloscope plug-ins. AM percentage of modulation is measured with Model 313 plug-in.
FM CAL	Adjusts center frequency of generated FM signal, as indicated on the FREQUENCY meter ± 5 kHz range. 100 kHz output may be used for greater resolution. Center frequency may be offset up to ± 5 kHz for test purposes.
-40 dB, X1, -20 dB, X10, 0 dB, X100	Adjusts output level in 20 dB steps. Multiplier for microvolt settings of Variable Attenuator.
-20 to 0 dB, .1-1.0 Microvolts	Variable attenuator control. Output level is the sum of the dB readings of the step attenuator and the variable attenuator. Microvolt output is the variable control setting multiplied by the step attenuator setting. Readings are correct only when 20 dB pad is used on the SIGNAL GEN OUT connector.
SIGNAL GEN OUT	Output of Signal Generator available at this connector at approximately 10 times the level indicated by the attenuator.

3.10 Make the following connections and settings:

- a) Connect an external antenna or the telescoping antenna supplied with the instrument to the ANT. connector. If the telescoping antenna is used, extend it to its full length for low band measurements, to approximately 18 inches for high band measurements, and use minimum length for UHF measurements.
- b) Turn the function switch to CAL.
- c) Adjust the inner knob (part of the function switch) for a zero (mid-scale) reading on the FREQUENCY meter.
- d) If the Model 301 Oscilloscope is being used, set the toggle switches for horizontal and vertical inputs to the INT. position and adjust the VERT. POS. control so that the trace is on the zero reference line while the deviation range switch is in the ± 1.5 position. Adjust the scope INTENSITY, FOCUS, and ASTIGMATISM controls for a sharp trace on the screen.
- e) Change the function switch to the MONITOR position.
- f) Dial in the assigned frequency of the transmitter with the six frequency selectors.
- g) Key the transmitter. The SIGNAL LEVEL light should come on. If it does not, move the CE-5 closer to the transmitter until the received signal is strong enough to turn on the light. Normally, measurements can be made easily when the CE-5 is between 25 and 50 feet from the radiating antenna. When a plug-in Preselector is being used, measurements can be made at distances of many miles from the transmitter, assuming the use of an adequate external antenna.
- h) Read the difference between transmitter's assigned frequency and actual, transmitted carrier frequency on the Frequency Meter. Select the appropriate, lowest meter range (with the lever switch just below the meter) for greatest resolution. Or connect a counter to the 100 kHz IF OUTPUT and read 100 kHz \pm the frequency error.
- i) Modulate the transmitter and read the FM deviation on the FM DEVIATION meter or the Oscilloscope. Select the appropriate meter or scope range with

the range switch (kHz knob on Deviation Meter, kHz lever switch on Oscilloscope). On the oscilloscope screen, peaks appear above and below the horizontal centerline of the display; the Deviation Meter indicates either positive or negative peaks, depending on the setting of the FM DEV PEAKS switch. If the DEVIATION PEAKS indicator level on the Deviation Meter plug-in has been set (see Model 302 Instruction Manual), all modulation peaks that exceed this level will cause the indicator to light.

j) If the Model 313 AM Monitor is plugged into the right hand compartment, connect the antenna to the connector on the Model 313, and perform the preceding steps (b) through (h). Modulate the transmitter (AM) and read the percentage of modulation on the Model 313 meter. Meter range is 0-100 % modulation.

AM/CW, FM SIGNAL GENERATION

3.11 CW Signal Generation

- a. Set the six frequency selector switches to the desired frequency.
- b. Place the function switch in the AM/CW position.
- c. Set INT MOD switch to OFF.
- d. Connect the coaxial cable and the 20-dB fixed attenuator (stored inside the front cover) between the panel connector, SIGNAL GEN. OUT, and the receiver to be tested. The variable attenuators will not read correctly unless the fixed attenuator is used.
- e. Adjust the output level with the SIGNAL GENERATOR coarse and fine attenuator controls.



Whenever a direct connection is made between the CE-5 and a transceiver, keying the transceiver will damage the 20 dB fixed attenuator and possibly the CE-5. A fuse is mounted in the 20 dB attenuator as a protective measure. A fuse is also installed in the output of the signal mixer in the CE-5.

3.12 AM Signal Generation

- a. Install a Model 313 AM Monitor in the right hand compartment of the CE-5. (AM signals may be generated without the Model 313 but percentage of modulation cannot be

monitored.)

- b. Make settings as in paragraph 3.11.
- c. For internal 1 kHz modulation only set the INT MOD switch to ON. (No signal should be connected to the EXT MOD connector.) Adjust percentage of modulation with the MOD ADJ control.
- d. For external modulation only set INT MOD switch to OFF. Connect external modulation source (60 Hz to 20 kHz) to EXT MOD connector. The external modulation signal may be a single tone or several tones summed together. Adjust modulation percentage with MOD ADJ control.
- e. For simultaneous internal and external modulation set INT MOD switch to ON and connect the external modulating signal to the EXT MOD connector. Adjust modulation level with the MOD ADJ control.

3.13 FM Signal Generation

- a. Set the frequency selector dials to the desired frequency.
- b. Place the function switch in the FM position.
- c. Set INT MOD switch to ON if internal 1 kHz modulation is desired. Adjust deviation with MOD ADJ control.
- d. If modulation from an external source is desired, connect source to EXT MOD. If simultaneous internal and external modulation is not desired set INT MOD switch to OFF. Adjust level with MOD ADJ control.
- e. In either c. or d. set the Frequency meter to 0 using the FM CAL control. The output frequency will now correspond to the frequency dialed in on the Frequency Selectors. The deviation may now be read on the Deviation meter or oscilloscope.
- f. Steps 3.11d, e and CAUTION note apply also to FM signal generation.

NOTE

The FM CAL control varies the center frequency of the FM signal and permits testing the alignment and maximum sensitivity of receivers. The FREQUENCY meter is automatically on the ± 5 kHz range when in the FM

position regardless of the position of the range switch.

AUDIO AND IF SIGNAL GENERATION

- 3.14 To generate these frequencies set the controls as follows:
 - a. Rotate the first frequency selector (on left side) to the extreme clockwise position so that IF shows in the display window. If the frequency display window light flashes on and off, this indicates a dialed in frequency which the CE-5 cannot generate. Only if the second frequency selector is turned to 0, 1, 2, or 3, will the light remain steady.
 - b. Set the IF FREQUENCIES range switch to either 0-4 or 4-40 MHz, as desired.
 - c. Dial in the desired IF or audio frequency. (Audio frequencies below 1 kHz can be generated; however, the output frequencies will have slight amounts of residual FM.)
 - d. The generated signal is available at the front panel IF FREQUENCIES OUTPUT connector. Its level can be varied with the IF LEVEL control.
 - e. The basic output frequency range is always 0-3,9999 MHz, variable in 100 Hz steps. When the switch is placed in the 4-40 MHz position, the 10th harmonic of the fundamental frequencies is used. Other harmonics are present also and can be used.

OUT OF BAND OPERATION

- 3.15 When using the Broadband Mixer plug-in or the Wideband mode in a Preselector, most of the frequencies between 520 MHz and 1030 MHz may be measured using the second harmonics of the CE-5 LO.
- 3.16 The frequencies that cannot be measured when using harmonic operation are: 590-610, 690-710, 790-810, 890-910 MHz. When making out of band measurements the measurement sensitivity will be less than in the normal 20-520 MHz band.
- 3.17 The required LO (f_4) for second harmonic operation is the desired frequency ± 10 MHz divided by 2. This frequency must fall within one of the LO (f_4) bands. See Table 3-2. The frequency that must be dialed in on the Monitor is the required LO (f_4) frequency ± 10 MHz. 10 MHz is subtracted if mixing is on the high side (Table 3-2) or 10 MHz is added if mixing is on the low side.
- 3.18 For example, to measure a frequency of 610 MHz, add 10 MHz to obtain 620 MHz and divide by 2 to get 310 MHz, the required LO frequency. (If 10 had been subtracted from 610 to

get 600 and divided by 2 to obtain 300, that frequency does not appear in Table 3-2 and so could not be used.) 310 MHz falls at the bottom of the 310-329.999 LO (f₄) which mixes on the high side. The dialed in frequency then will be 310-10 = 300 MHz.

3.19 Another example, for a frequency of 589 MHz, 589-10 = 579, divided by 2 equals 289.5 MHz. This falls at the top of the 260-289.999 band which mixes on the low side. The dialed in frequency will be 289.5+10 = 299.5 MHz.

These examples were chosen to illustrate the fact that there is no L.O. frequency available for frequencies between 589.999 and 610 MHz which would require an L.O. between 289.999 and 310 MHz.

3.20 To generate second harmonic signals the dialed in frequency will be the desired frequency divided by 2. Since the output being used is the second harmonic of the generated frequency the attenuator calibration will not apply.

Table 3-2. Synthesizer Frequency Relationships

DIAL SETTING	VARIABLE FREQUENCY F1	FIXED FREQUENCY F2	FIXED FREQUENCY F3	LO FREQUENCY TO PLUG-IN OR M3 F4	MIXING SIDE
20 - 39.999	460 - 479.999	0	-430	30 - 49.999	HIGH
40 - 79.999	460 - 499.999	0	-430	30 - 69.999	LOW
80 - 99.999	460 - 479.999	+60	-430	90 - 109.999	HIGH
100 - 119.999	460 - 479.999	+60	-430	90 - 109.999	LOW
120 - 139.999	460 - 479.999	+100	-430	130 - 149.999	HIGH
140 - 179.999	460 - 499.999	+100	-430	130 - 169.999	LOW
180 - 199.999	460 - 479.999	+160	-430	190 - 209.999	HIGH
200 - 219.999	460 - 479.999	+160	-430	190 - 209.999	LOW
220 - 249.999	460 - 489.999	+200	-430	230 - 259.999	HIGH
250 - 269.999	460 - 479.999	-200	0	260 - 279.999	HIGH
270 - 299.999	460 - 489.999	-200	0	260 - 289.999	LOW
300 - 319.999	470 - 489.999	-160	0	310 - 329.999	HIGH
320 - 349.999	470 - 499.999	-160	0	310 - 339.999	LOW
350 - 369.999	460 - 479.999	-100	0	360 - 379.999	HIGH
370 - 399.999	460 - 489.999	-100	0	360 - 389.999	LOW
400 - 419.999	470 - 489.999	-60	0	410 - 429.999	HIGH
420 - 449.999	470 - 499.999	-60	0	410 - 439.999	LOW
450 - 469.999	460 - 479.999	0	0	460 - 479.999	HIGH
470 - 519.999	460 - 509.999	0	0	460 - 509.999	LOW

NOTES: 1. ALL FREQUENCIES ARE IN MHZ.
 2. THE LAST 4 DIGITS OF THE 6-10 MHZ VCO, THE BALANCED MIXER, AND THE OUTPUT MIXER FREQUENCIES ARE THE SAME AS THE LAST 4 DIGITS OF THE DIALED-IN FREQUENCY.

DIAL INDICATOR LIGHT REPLACEMENT

3.21 To change the Frequency Selector indicator lights or the decimal point lights, proceed as follows:

- a. Remove the plug-in units.
- b. Remove the side covers of the CE-5.
- c. Remove one or both plug-in trays. If the burned out light is not in the center only the tray on one side needs to be removed. (The right hand tray is held by four flat head screws. The left hand

tray has, in addition, a spacer mounted to the center plate. Remove the screw from the center plate end of the spacer.)

- d. Very carefully unsolder the two light connecting leads from the terminals. (Use a shield between the adjacent wires and the soldering iron to prevent burning the insulation.) Remove the light.
- e. Insert a new light, with sleeving on the connecting leads, and solder to the proper terminals.
- f. Replace the trays, side covers and plug-in units.

SECTION 4

THEORY OF OPERATION

INTRODUCTION

4.01 This section begins with a description of the circuit reference series of identifying numbers assigned to the different circuit boards. A general description of the overall operation of the Monitor is followed by a description of the frequency synthesizer. The section concludes with a description of the operation of the individual circuits.

4.02 The circuits of the instrument are referred to by the Circuit Reference Series A2-A25. A1 and A21 are not used. A20, A22, A23, A24, A25 refer to the circuits mounted directly on the Front Panel, Rear Panel, Main Chassis and Center Plate assemblies respectively. A board number is etched on each circuit board. The Circuit Reference Series, the Assembly number and the Figure numbers are cross referenced to the board number in Table 6-1. A9, A10 are mounted within a container assembly because these circuits must be specially shielded. The Circuit Reference Series, the assembly number and the jack number are screened on the chassis next to the jack connectors.

4.03 The components on each circuit board are numbered in sequence on that board. The complete identification of a component combines the Circuit Reference Series number and the board component number. For example, the first numbered resistor on the 6-10 MHz VCO board will be A2R1 and the third transistor A2Q3 etc. In describing the individual boards only the board sequence will be used, and only when reference is made to a component outside that board will the complete identification be given.

FUNCTIONAL DESCRIPTION

4.04 The CE-5 Communications Monitor is essentially a VHF/UHF superheterodyne receiver with front end Preselectors covering different frequency bands. Each Preselector operates in a Tuneable Mode over a selected band with high input sensitivity and in the Wideband mode (Preselector untuned) over the full range to which the Monitor may be tuned, with a reduced sensitivity. See Overall Block Diagram Figure 4-5.

4.05 The major portion of the circuitry in the Monitor is for the purpose of generating, synthesizing and controlling the Local Oscillator frequency. In the Receive Mode the Local Oscillator frequency is either 10 MHz above or 10 MHz below the frequency dialed up on the Monitor so as to produce a 10 MHz Preselector IF output.

4.06 In the Signal Generator mode the L. O. out-

put signal is shifted 10 MHz so that it corresponds to the frequency dialed up and is then used as the output frequency. This frequency shift is accomplished by mixing the L. O. with a 10 MHz signal. In the AM/CW mode this signal comes from the synthesizer and may be amplitude modulated. In the FM mode this 10 MHz signal is supplied by a 10 MHz VCO which is frequency modulated by either the internal 1 kHz or external modulating signal, or both. The center frequency is adjusted to the synthesizer frequency by the front panel FM CAL adjustment.

4.07 Frequency synthesis begins with a stable 3 MHz crystal oscillator mounted in a temperature controlled oven. All frequencies used are derived from or compared to this source. Signals are produced either by harmonic generation or mixing. Accuracy is maintained by phase locking the outputs to the master oscillator. In this way the accuracy of this very stable Master oscillator is maintained throughout the whole instrument. Thus the Local Oscillator signal becomes a standard frequency to which an incoming signal is compared. In the signal generating mode this same accuracy is maintained.

4.08 Signals in the range of 1 kHz to 40 MHz are available at the IF Output connector when the first frequency digit switch is placed in the IF position. These frequencies also come from the frequency synthesizer.

4.09 Input signals are mixed with the L. O. in the preselector to produce a 10 MHz IF Output. This signal is mixed with a 9.9 MHz L. O. output from the synthesizer to produce a second IF of 100 kHz. Since both L. O. signals are the standards generated by the synthesizer, the frequency error of the input signal, if any, will appear on the signal in the second IF. Frequency error detector circuits display this error on the FREQUENCY meter which is calibrated directly in kHz.

4.10 The modulation (FM) is also recovered by these circuits and displayed either on the oscilloscope or deviation meter plug-in. AM is detected and displayed by the Model 313 plug-in. Audio output is amplified and reproduced in the speaker.

4.11 Frequency Synthesizer

4.12 The Frequency Synthesizer consists of a crystal controlled Master Oscillator (M.O.), a phase locked loop made up of a voltage controlled oscillator (VCO), a Divide-by-N Counter ($\div N$) with a phase detector and associated circuits, harmonic generators, multipliers and various mixers.

4.13 The basic frequency is generated by the crystal controlled M.O. The M.O. output is divided and multiplied to provide most of the fixed frequencies required. It is used for reference in the phase locked loops of the Programmable Phase Locked Loop which supplies the remainder of the fixed frequencies and in the 6-10 MHz VCO which provides the variable frequency required for the complete coverage of the band of Local Oscillator (L.O.) frequencies.

4.14 The VCO operates at frequencies from 6 to 10 MHz. Either 40 or 42 MHz is added to this output in the Balanced mixer, then the output is multiplied by ten to produce the variable part of the L.O. frequency. As the case requires, either none, one or two fixed frequencies are added to or subtracted from the variable output to produce the required L.O. frequency. This L.O. will be either 10 MHz lower or 10 MHz higher than the frequency that is dialed in on the monitor in the Receive mode. In the Signal Generator mode 10 MHz is either added to or subtracted from the L.O. and the result is then used as the output. The output frequency now is the same as the frequency dialed in on the monitor. Table 4-1 shows the relationships between these frequencies.

4.15 For instance, if the number "123.456" is

dialed in, the VCO oscillates at 6.3456 MHz; adding 40 MHz gives 46.3456 MHz; multiplying by ten brings the frequency to 463.456 MHz; adding 100 MHz and subtracting 430 MHz gives an L.O. of 133.456 MHz, 10 MHz higher than the 123.456 MHz that was dialed in.

4.16 When a frequency is dialed in, the VCO is adjusted to within 100 kHz of the frequency it must produce by the settings of the first, second, and third frequency selectors. For the values used in the example (123.456/6.3456) this is between 6.3000 and 6.4000 MHz. The setting of all six frequency selectors program the ÷N Counter to the exact VCO frequency associated with this setting. At first the frequency at which the VCO oscillates is not exact to the last three digits and it "hunts" for a few cycles. When the frequency is exactly right, but not until then, the ÷N counter produces a 100 Hz output signal.

4.17 Figure 4-1 is a simplified block diagram of the frequency synthesizer. The loop is shown in the phase-locked condition and therefore the ÷N output is represented as being 100 Hz.

4.18 For the VCO to produce a signal with a frequency of 6.3456 MHz or, 6,345,600 Hz, the input to the ÷N counter must be 6,345,600 pulses

Table 4-1. Synthesizer Frequency Relationships

DIAL SETTING	VARIABLE FREQUENCY F1	FIXED FREQUENCY F2	FIXED FREQUENCY F3	LO FREQUENCY TO PLUG-IN OR M3 F4	MIXING SIDE
20 - 39.999	460 - 479.999	0	-430	30 - 49.999	HIGH
40 - 79.999	460 - 499.999	0	-430	30 - 69.999	LOW
80 - 99.999	460 - 479.999	+60	-430	90 - 109.999	HIGH
100 - 119.999	460 - 479.999	+60	-430	90 - 109.999	LOW
120 - 139.999	460 - 479.999	+100	-430	130 - 149.999	HIGH
140 - 179.999	460 - 499.999	+100	-430	130 - 169.999	LOW
180 - 199.999	460 - 479.999	+160	-430	190 - 209.999	HIGH
200 - 219.999	460 - 479.999	+160	-430	190 - 209.999	LOW
220 - 249.999	460 - 489.999	+200	-430	230 - 259.999	HIGH
250 - 269.999	460 - 479.999	-200	0	260 - 279.999	HIGH
270 - 299.999	460 - 489.999	-200	0	260 - 289.999	LOW
300 - 319.999	470 - 489.999	-160	0	310 - 329.999	HIGH
320 - 349.999	470 - 499.999	-160	0	310 - 339.999	LOW
350 - 369.999	460 - 479.999	-100	0	360 - 379.999	HIGH
370 - 399.999	460 - 489.999	-100	0	360 - 389.999	LOW
400 - 419.999	470 - 489.999	-60	0	410 - 429.999	HIGH
420 - 449.999	470 - 499.999	-60	0	410 - 439.999	LOW
450 - 469.999	460 - 479.999	0	0	460 - 479.999	HIGH
470 - 519.999	460 - 509.999	0	0	460 - 509.999	LOW

NOTES: 1. ALL FREQUENCIES ARE IN MHZ.
 2. THE LAST 4 DIGITS OF THE 6-10 MHZ VCO, THE BALANCED MIXER, AND THE OUTPUT MIXER FREQUENCIES ARE THE SAME AS THE LAST 4 DIGITS OF THE DIALED-IN FREQUENCY.

per second. The counter divides this input by "N" which stands for the variable quantity for which it can be programmed. In the example $N=63,456$ and $6,345,600 \div 63,456 = 100$. Thus, except for the very short time during which the VCO "hunts" for the correct frequency, the $\div N$ counter output is always 100 pulse per second or 100 Hz.

4.19 The 100 Hz output of the $\div N$ counter is phase-compared with a stable 100 Hz signal from the M.O. When the signals have the proper phase relationship, this condition is represented by a pulse of a certain duration from the Phase Detector. Each pulse is transformed into a ramp voltage by the Ramp Generator with a duration that is proportional to the width of the pulse. Each ramp is sampled by the 100 Hz from the $\div N$ counter and a capacitor is charged to the amplitude of the sample. The capacitor retains a certain portion of its charge and after a suitable delay a second sampling takes place. A second capacitor charges to a potential corresponding to the charge that

is retained by the first capacitor and the second capacitor retains this exact charge for as long as the two 100 Hz signals have the proper phase relationship. The potential to which the second capacitor charges is used as a control voltage on a Varicap in the VCO circuit. Since it is a Varicap characteristic to change capacitance according to a control voltage, it acts as a fine-tuning device to adjust the VCO to precisely the frequency required.

4.20 The 6-10 MHz VCO output is combined with either a 40 or a 42 MHz signal in the Balanced Mixer and multiplied by ten in the X10 Multiplier. The signal is then filtered by the 460 to 512 MHz Filter and finally a fixed frequency is added or subtracted. The fixed frequency may be zero, 60, 100, 160, 200, 430 MHz or one of the other four frequencies combined with 430 MHz in the RF mixer. See Table 4-1.

4.21 The output of the RF Mixer (which con-

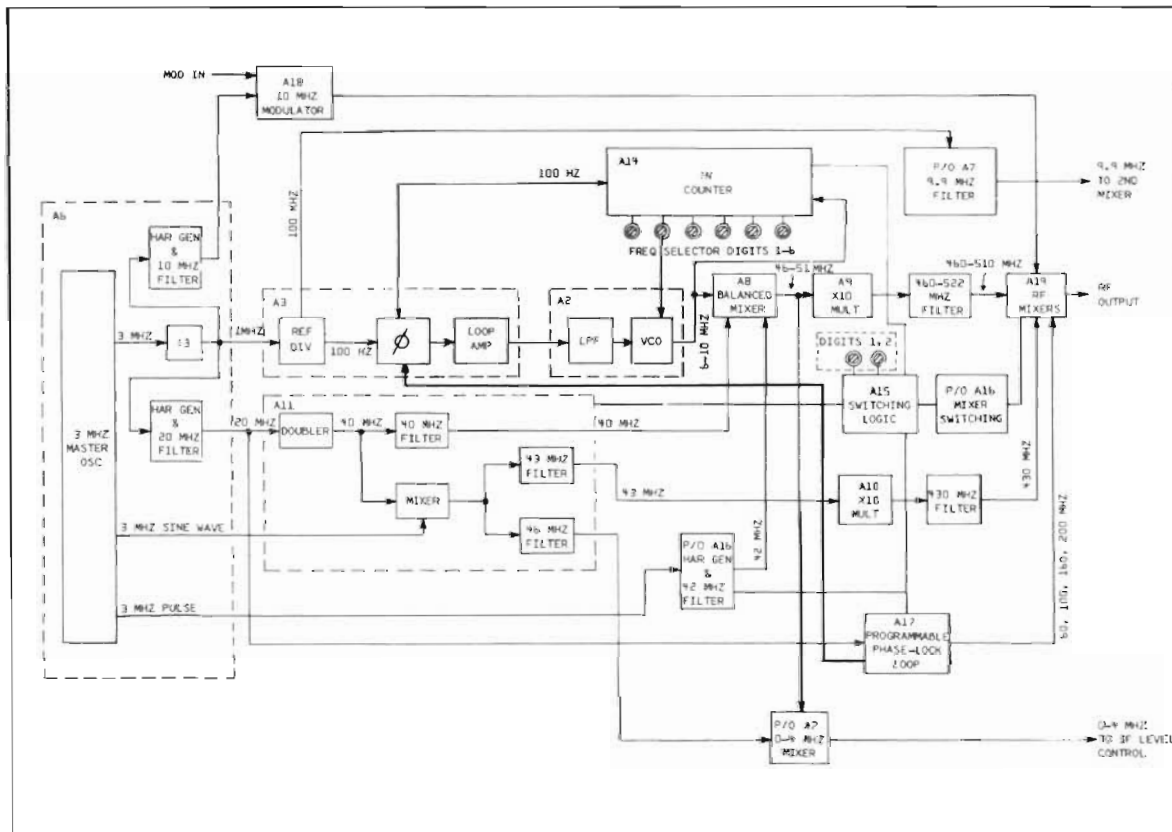

Figure 4-1. Frequency Synthesizer, Simplified Block Diagram

sits of the multiplied and filtered Balanced Mixer output and the fixed frequency) is passed through a pin diode switch to the mixer in the RF plug-in unit. See Overall Block Diagram Figure 4-5. In the RF plug-in the local oscillator input and the incoming RF signal are mixed to produce the 10 MHz IF.

4.22 When the CE-5 is used as a signal generator, (FM or AM/CW) the output is switched to the Signal Generator Mixer where, in addition to mixing the Balanced Mixer output with the fixed frequency, 10 MHz is added or subtracted to make the SIGNAL GEN OUT signal coincide with the dialed-in frequency.

4.23 When the CE-5 is used to generate signals in the audio or IF range, signal processing is as has been described for the Receive mode, but only up to the point where the signal has passed through the Balanced Mixer. The balanced mixer output is fed to the 0-4 MHz Mixer, which is turned on to generate audio and IF signals. Table 4-2

Table 4-2. Frequency Relationships, Audio and I. F. Signal Generation

Frequency Selector Setting	VCO Frequency (MHz)	Balanced Mixer Output (MHz)	To 0-4 MHz Mixer (MHz)	0-4 MHz Mixer Output (MHz)
0.0000 - 0.9999	6.0000 - 6.9999	46.0000 - 46.9999	46.0000	0.0000 - 0.9999
1.0000 - 1.9999	7.0000 - 7.9999	47.0000 - 47.9999	46.0000	1.0000 - 1.9999
2.0000 - 2.9999	8.0000 - 8.9999	48.0000 - 48.9999	46.0000	2.0000 - 2.9999
3.0000 - 3.9999	9.0000 - 9.9999	49.0000 - 49.9999	46.0000	3.0000 - 3.9999

NOTES: 1. First Digit Frequency Selector Knob set to I. F.
2. Fixed frequency input to Balanced Mixer is 40 MHz

shows the frequency relationships in the Frequency Synthesizer in this case.

4.24 A 40 MHz fixed frequency is added to the 6-10 MHz VCO output in the Balanced Mixer when generating audio and IF signals. The Balanced Mixer output is mixed with a 46 MHz fixed frequency in the 0-4 MHz Mixer to produce signals that vary between 1 kHz and 4 MHz according to the setting of the frequency selectors. (Frequencies between 0 and 1 kHz are present but not recommended for use). When the IF FREQUENCIES selector is moved to the 4-40 MHz position the harmonics of signals from 0.4 MHz are enhanced and can be used.

4.25 The Frequency Synthesizer also provides a 10 MHz and a 9.9 MHz output. The 10 MHz signal is used for calibration and AM/CW generation. The 9.9 MHz signal is mixed with the output of the RF plug-in to produce the 100 kHz second IF frequency.

CIRCUIT DESCRIPTION

4.26 Master Oscillator, Divider and Filters. A6.

4.27 This circuit provides the following outputs:

- a. A 1 MHz signal for the Reference Divider.
- b. A 3 MHz sine wave for the 43 MHz and 46 MHz mixer and filters.
- c. A 3 MHz pulse output for the 42 MHz harmonic generator and filter.
- d. A 10 MHz signal for discriminator calibration and AM/CW generation.
- e. A 20 MHz signal for the 40 MHz mixer and the programmable phase locked loop.

4.28 As shown in the schematic, Figure 6-5, transistor Q1 is part of a modified Pierce oscillator circuit. The 3 MHz crystal is electrically in the base circuit of Q1 but physically in a separate Crystal Oven. The 3 MHz sine wave output of the oscillator is fed through untuned isolation amplifier Q2 to Q10 and also to board pin 4. Q10, Q11, and Q12 form a pulse shaper which changes the 3 MHz sine wave to a square wave. This 3 MHz pulse output is fed to the 42 MHz filter via board pin 7 and also to IC1, which is connected as a ÷3 counter. Pulse-shaper, IC3, accepts the 1 MHz signal and provides an output, rich in harmonics, to the 10 MHz and 20 MHz filters on the board itself and via board pin 13 to the Reference Divider.

4.29 The 10 MHz and 20 MHz filters are amplifiers in which the output of each stage is tuned to the desired frequency, Q4, Q6, for 10 MHz and Q3, Q5, Q7, Q8, Q9 for 20 MHz. The 10th or 20th harmonic of the input, 1 MHz, signal is selected and amplified to provide the desired frequency output at the proper level. The 10 MHz output, through board pin 9, goes to the 10 MHz Modulator and the 20 MHz output, through board pin 17, goes to the 40 MHz Mixer and the Programmable Phase Lock Loop.

4.30 Reference Divider/Phase Detector. A3

4.31 The Reference Divider circuit is shown in the upper part of Figure 6-2. The 1 MHz signal from the M. O. is divided by decade counters IC1, IC3, IC4, and IC5. Three different frequencies are taken from this divider. 100 kHz to the 9.9 MHz mixer, buffered through IC2C, 1 kHz to the 10 MHz Modulator, buffered through IC6A and 100 Hz to the phase detector, buffered through IC6B.

4.32 The phase detector, IC7, takes the 100 Hz reference output of the Reference Divider and the 100 Hz out of the ÷N Circuit, through board pin 8, and produces constant amplitude output pulses at D1 and U1 which vary in phase as the 100 Hz ÷N signal varies from the 100 Hz reference signal in both frequency and phase.

4.33 The output of IC7 is detected by the circuit made up of Q1, Q2, Q3, Q4 and diodes CR2-CR5 to produce a DC level that varies according to the difference in frequency and phase between the $\div N$ 100 Hz and the Reference Divider 100 Hz inputs. This DC (pulsating) level is amplified by the loop amplifier, IC8, and fed to the 6-10 MHz VCO.

4.34 As long as the D1 and U1 outputs of IC7 are both high during the same period, the locked condition, the output of IC9A is low, inhibiting the one-shots IC9B, C, D and IC10B, C, D. When there is no output from the one-shots Q5 is off and the UNLOCK indicator light is off. When the $\div N$ 100 Hz frequency drifts (unlocked condition) the one-shots are enabled and the output switches Q5 on which causes the UNLOCK light to come on.

4.35 The unlock signal from the programmable phase lock loop circuit, A17, is brought in through board pin 17, amplified by IC11 and applied to Q5 through CR1 so that the UNLOCK light may also be controlled by this circuit.

4.36 6-10 MHz VCO. A2

4.37 The pulsating DC output from the loop amplifier on the Reference Divider/Phase Detector board, A3, comes in through board pin 3 to the 100 Hz notch filter which removes the 100 Hz component. The 50 Hz and 70 Hz active filters Q1-Q6 remove any remaining sideband frequencies. The DC output is then applied to the Varicap diode CR2 to control the frequency of the VCO, Q8. Thus as the division number in the $\div N$ circuit, A14, changes, the voltage applied to CR2 changes to force the frequency to that required by the $\div N$ circuit to produce a 100 Hz output.

4.38 The frequency determining components of the tank circuit of the VCO are L4, L5, C19 and the capacitance of CR1 when it is reverse biased. This is the set-up for the VCO frequency range of 6-8 MHz.

Table 4-3. VCO Tank Circuits Selected by First and Second Frequency Selectors

	Second	0	1	2	3	4	5	6	7	8	9
First	0, 1	I	I	I	I	I	I	II	III	I	I
	2	I	I	I	I	II	I	I	I	I	II
	3, 4, 5	I	II	I	II	III	I	I	I	I	II
	IF	I	I	II	III	-	-	-	-	-	-

I represents 6-8 MHz Tank Circuit
 II represents CR3 biased on } 8-10 MHz Tank Circuit
 III represents CR4 biased on }

4.39 To cover the 8-10 MHz range the output of the Switching Logic Circuit, A15, grounds either CR3 or CR4. This biases Q7 on and causes

CR1 to conduct. This effectively switches out the capacitance of CR1 and the inductance of L4, leaving L5, C19 to form the tank circuit.

4.40 Q9 is an on board regulator for the bias voltages of the oscillator, Q8. Q10 is an output buffer for the 6-10 MHz signal to the Balanced Mixer and Q11 buffers the output to the $\div N$ circuit.

4.41 Divide-by-N Counter. A14

4.42 The function of the $\div N$ circuit is to divide the 6-10 MHz VCO output frequency by a number (N) determined by the setting of the Frequency Selector switches, which will cause the output to be 100 Hz when the VCO frequency is correct.

4.43 As has been stated, the VCO must produce a signal with a frequency of 6.3456 MHz for a dialed-in frequency of 123.456 MHz. The VCO sine wave output is connected to the clock pulse-forming network, IC7 (Figures 4-2 and 6-13). In the example, the $\div N$ Counter must count 6,345,600 pulses per second and produce a signal of 100 pulses per second (100 Hz). This means that for every 63,456 input (clock) pulses, the counter must produce one output pulse. $\div N$, in this case, is 63,456.

4.44 When mention is made of the "count" of a decade, this is a reference to the combination of binary states of the four flip-flops that are contained in the decade counter IC's (IC1, IC2, IC3, IC4, IC6, IC9). Each flip-flop is either on or off, it is either in binary state 1 or binary state 0. When counting the decades successively assume binary coded decimal (BCD) counts 0 through 9. The correlation between the binary state

Table 4-4. Decimal count of a Decade and the Binary States of its Flip-Flops

Decimal Count	FF-1	FF-2	FF-3	FF-4
0	0	0	0	0
1	0	0	0	1
2	0	0	1	0
3	0	0	1	1
4	0	1	0	0
5	0	1	0	1
6	0	1	1	0
7	0	1	1	1
8	1	0	0	0
9	1	0	0	1

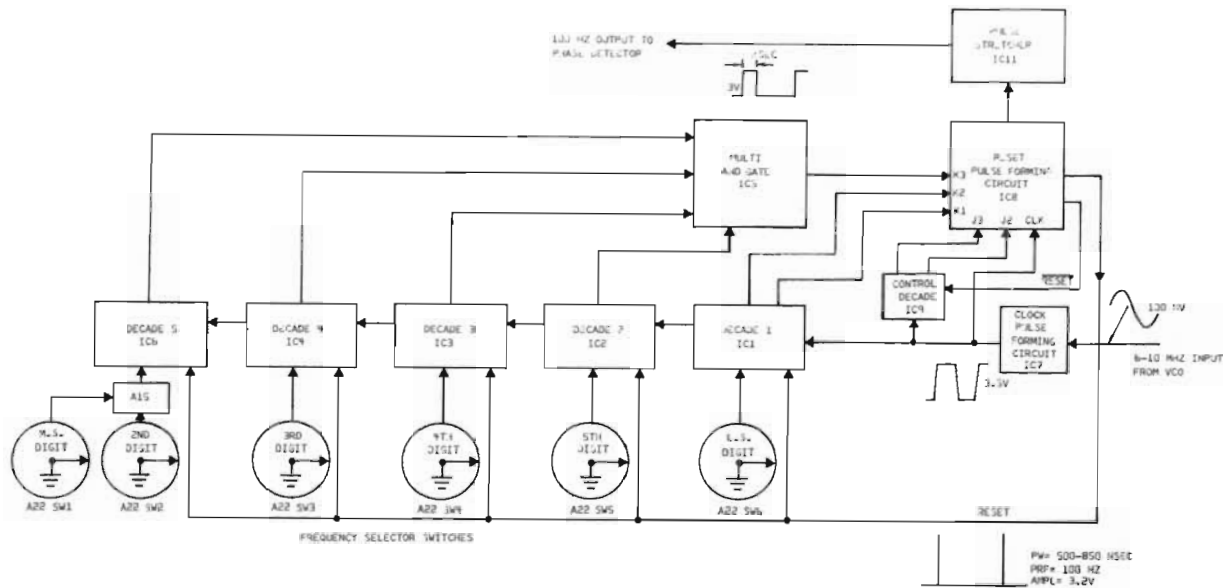

Figure 4-2. Divid-by-N Counter, Simplified Block Diagram

of a flip-flop and the decimal count of the decade is as shown in Table 4-4.

4.45 The $\div N$ Counter consists mainly of decade counters and gating circuits. There are five counting decades, IC1, IC2, IC3, IC4, IC6, and one control decade, IC9, all identical and each capable of counting to ten (a decade). For each ten-count a decade produces one output pulse. Thus, if the first decade counts to ten and produces an output pulse and the second decade counts the output pulses of the first decade to produce its one output pulse, the second decade produces one pulse for every one hundred pulses counted by the first decade. With a third, fourth and fifth decade, the counter as a whole will count 100,000 before the last (fifth) decade can produce its first output pulse.

4.46 The decades count continuously, but they can only count to ten. Further, since zero is considered a count, the decades count from 0 to 9. When there is an input signal the five decades cannot return to zero together until they have counted the full count of 100,000 or, from 0 to 99,999.

4.47 To reach a count other than a full count of 99,999, for instance the 63,456 count of the example, each decade must be preset. This is done with the frequency selectors on the CE-5 front panel.

4.48 When the least significant digit of the frequency selector is turned to 6 (63,456) IC1 is preset to 3 ($9-6=3$). The other four decades are preset or programmed for 4 ($9-5=4$), 5 ($9-4=5$), 6 ($9-3=6$), and 3 ($9-6=3$). When $N=63,456$ the decades are preset to 36,543, so that they need to count only 63,456 pulses to reach their first full count of 99,999.

4.49 During the last ten-count by the first decade all other decades will already have reached 9. During the last ten-count a sixth, control decade, senses that the five counting decades are nearing a full count. Specifically, when IC2, IC3, IC4, IC6 are at count 9 and the first decade reaches count 4 (five more counts to 99,999), the last five pulses are not fed to the first decade but are used in the reset pulse forming network to produce the reset pulse.

4.50 At this count of 4 in the first decade, IC1, IC8 changes state to generate the $\div N$ output pulse. The beginning of this pulse transfers the input clock signal to IC9 and also resets the dividers IC1, 2, 3, 4, 6 to the preset number determined by the dial settings. When IC9 reaches the count of 9, from its preset count of 5, IC8 again changes state to terminate the $\div N$ output pulse and transfer the input clock signal back to IC1 so that at the 0 count the dividers may again start counting from the preset number.

4.51 Thus, there is one reset pulse for each 63,456 input or clock pulse. And, since (in this example) the VCO signal consists of 6,345,600 pulses per second (6.3456 MHz), there will be 100 reset pulses per second or, a signal with a pulse repetition frequency of 100 Hz. This signal, made up of reset pulses is the output of the $\div N$ circuit which is compared with the M.O. signal in the Phase Detector.

4.52 In a signal which contains between 6,000,000 and 10,000,000 pulses per second (the VCO range of 6 to 10 MHz) each clock pulse has a duration of between 100 and 170 nanoseconds. Since it takes the duration of five clock pulses to form the reset pulse, this reset pulse will be of 500 to 850 nanoseconds duration.

4.53 Pulses of this short duration, even if they occur at the correct frequency, cannot be used to compare with the 100 Hz signal from the M.O. A pulse stretching circuit, IC11, is used to lengthen each individual pulse to 350 microseconds.

4.54 The pre-setting of the decades is performed with the frequency selectors and consists of grounding or not grounding the preset input to each flip-flop in the correct combination when the desired number is dialed. Each frequency selector (except the first and the second) is associated with a binary-coded rotary switch which is constructed so that there is one terminal connection to the preset input of each flip-flop. Thus, when a digit is selected, the four flip-flops in each decade are grounded or not grounded as is appropriate for the required preset count of the decade.

4.55 The first and second frequency selectors are both associated with the fifth decade, through IC10. Because of the frequency relationship between the dialed in frequencies and the VCO frequencies (Table 4-1) the numbers dialed in have no direct numerical relationship with the associated preset state of the fifth decade. In the example for instance, the third digit dialed in and displayed is a 3 (123, 456 MHz), the second digit of the associated VCO frequency is also 3 (6, 3456 MHz). The numerical relationship between the 3 and the preset state of the decade is simply 9-3=6. The first and second digits of the dialed-in frequency are 1 and 2 (123, 456). The VCO has no digit corresponding to the first dialed-in digit; and the first VCO digit, corresponding to the second dialed in digit, is 6 (6.3456) not 2. Thus, there is no simple numerical relationship; instead, since the first digit of the VCO frequency is arbitrarily 6, 7, 8, or 9; the state of the fifth decade is 3, 2, 1, or 0. Table 4-5 shows which fifth decade state results from which combination of positions of the first and second frequency selectors.

4.56 40 MHz, 43 MHz and 46 MHz Filters. A11

4.57 The circuits on this board convert 20 MHz and 3 MHz Master Oscillator outputs to signals with frequencies of 40, 43 and 46 MHz.

Table 4-5. Fifth Decade Count Preset by First and Second Frequency Selectors

First \ Second	0	1	2	3	4	5	6	7	8	9
0, 1	3	2	3	2	3	2	1	0	3	2
2	3	2	3	2	1	3	2	3	2	1
3, 4, 5	2	1	2	1	0	3	2	3	2	1
IF	3	2	1	0	-	-	-	-	-	-

4.58 The 20 MHz signal from the Master Oscillator is doubled by Q1, Figure 6-10. Isolation amplifier Q7 feeds this 40 MHz signal to the Balanced Mixer, through board pin 15, only

when +20V DC is applied to pin 13. This DC voltage is applied when the first frequency selector is in the 1, 2, 3, 4 IF position, but not when it is in the 5 position.

4.59 In addition, the 40 MHz output of Q1 is fed through amplifier Q2 to mixer CR2/CR3, where it is combined with a 3 MHz signal from the Master Oscillator. The output of this mixer contains both 40 MHz + 3 MHz = 43 MHz and 40 MHz + 2nd harmonic of 3 MHz = 46 MHz. The output containing the two frequencies is filtered by the harmonic amplifier filter, Q3-Q6 providing a 43 MHz signal at board pin 22. A similar filter, consisting of Q8, Q9 and Q10, makes a 46 MHz signal available at board pin 2. 43 MHz output is switched on when frequencies between 20-249,999 MHz are dialed up. 46 MHz output is used only when the first digit dial is in the IF position.

4.60 42 MHz Filter, Audio Amplifier, Mixer and IF Switching. A16.

4.61 Three different functions are performed on this board. See Figure 6-15. There is a harmonic generator for 42 MHz, an audio amplifier and the switching control for the RF mixers and the IF signals used in mixing for the L.O. output.

4.62 Audio output from the Discriminator circuit is amplified by IC1 and connected to the speaker at pin 7.

4.63 3 MHz pulses from the Master Oscillator/Divider are shaped into narrow pulses by IC3 and passed through harmonic amplifier filter Q5, Q8, Q13, Q21. These stages amplify the 42 MHz component of the input pulse to the level required for mixing.

4.64 The switching circuits on this board control the 43 MHz filter, the 43 MHz X10 multiplier and the RF Mixers. The first two digits (100 MHz and 10 MHz frequency selector switches) through the Switching Logic, A15, control an input to pin 21. This input enables the 43 MHz Filter and the 43 MHz X10 Multiplier through Q9, Q14, Q18, to switch in the 430 MHz fixed frequency when necessary. See Table 4-1.

4.65 Input from the first two digits through pins 18 and 21 control the switch made up of Q1, Q2, Q3, and IC2 which selects one of the four transistor switches connected to the outputs of IC2. Outputs from these switches through pins 13, 14, 15, 17 control the RF mixers. In this way the RF mixers are programmed to accept the output of the programmable Phase Lock Loop or the 430 MHz output of the 43 MHz X10 multiplier or both as required. See Table 4-1.

4.66 Balanced Mixer. A8

4.67 The circuits on this board add either a 40 MHz or a 42 MHz signal to an input

from the 6-10 MHz VCO. The 40 MHz signal comes from the 40 MHz Filter (A11), and the 42 MHz signal comes from the 42 MHz Filter (A16). Both inputs are applied to board pin 2 but only one of the sources is ever activated at a time. The frequency selectors have been wired, to apply +20 V to the selected filter to turn it on.

4.68 Buffer Amplifier, Q1, Figure 6-7, provides amplification of whichever input is received and its output is applied to the double balanced mixer through the primary of mixer transformer, T1. The input from the VCO enters the board at pin 11 and is amplified by IC1. The gain is automatically controlled by a DC signal from a level detector on the 46 to 50.99 MHz Multiplier board, A9. This Automatic Level Control (ALC) signal enters the board at board pin 14 and is amplified by IC2 before being applied to IC1. The controlled VCO output of IC1 is then fed to the center tap of transformer T2 through emitter follower, Q4 and band pass filter L12-14, C34-40. This transformer together with T1, CR1, CR2, CR3, and CR4 form the double balanced mixer. The output of T2 is fed to a Bandpass Amplifier which passes and amplifies only the frequencies between 46 and 50.99 MHz. The Bandpass Amplifier provides two outputs, a normal output at pin 21 and an attenuated output at pin 18.

4.69 46-50.99 MHz X10 Multiplier. A9

4.70 The input signal from the Balanced Mixer is connected through J1 to CR1, R1 and T1. Figure 6-8. Part of the input signal is rectified by CR1 and fed back to the Balanced Mixer as the Automatic Level control voltage. T1 with CR2, CR3 doubles the frequency and it is amplified by the tuned amplifiers Q1-Q3 and applied to snap diode CR4. The fast turn-off characteristics of this diode produces a signal very rich in harmonics. The fifth harmonic of the doubled signal is selected by the 460-522 MHz filter FIL-1 to provide the required 460-510 MHz output.

4.71 43 MHz X10 Multiplier. A10

4.72 Input to this circuit from the 43 MHz filter through J1 is amplified by Q1. Figure 6-9. The second harmonic of this signal is amplified by Q2, Q3 and applied to the snap diode, CR2, to provide an output rich in harmonics. The 430 MHz filter, FIL-1 selects the fifth harmonic of the doubled frequency to provide the 430 MHz required in the RF Mixer.

4.73 Programmable Phase Lock Loop and Amplifier. A17

4.74 The main components of this circuit are the Voltage Controlled Oscillator (VCO) and the Phase Detector. The VCO is programmed by switching inductances in the oscillator tank circuit and capacitances in the feedback circuit. Figure 6-16.

4.75 Switching in the RF circuits is accomplished with PIN diodes. These very low capacitance diodes are isolated from the control circuits or power supply by RF chokes and resistors. When forward biased they offer a low impedance path to RF signals and when reverse biased they are effectively an open circuit.

4.76 The VCO, Q8, is in a common base configuration. The variable capacitance is furnished by Varicap, CR11, and the variable inductance by L4, L5, L8. Feedback capacitors are C1, C6, C10 and the residual capacitance of the PIN diodes CR9, CR10 when they are nonconducting. Since these capacitances are in series the smallest value in the circuit is dominant. Additional Varicap bias is added when 200 MHz is selected.

4.77 The inductors and capacitors that are selected for the four frequencies when a positive voltage is applied to one of the input pin connectors are shown in Table 4-6. The four inputs from the Frequency Selector switching logic program the diodes CR1-CR8 to control the transistors which in turn control the PIN diode switches. C10 is switches in by CR9, Q1; C6 by CR10, Q2; L5 by CR12, Q3, Q6, Q11; and L8 by CR15, Q4, Q7, Q12. Additional Varicap bias is switched into the loop amplifier, IC1, by Q13. R58 adjusts the level of this additional bias. Q5, Q9, Q10 form the amplifier on-off control switch, supplying -12V to the amplifiers Q15-Q18 and to some of the transistor switches. CR14 prevents undesirable DC feedback when the VCO is off.

Table 4-6. Programmable Phase Lock Loop Switching

Input Pin	Output Frequency	Inductance	Feedback Capacitor	Additional Varicap Bias
20, X	60 MHz	L4	C10	No
18, V	100 MHz	L4, L5	C10	No
19, W	160 MHz	L4, L5, L8	C6	No
21, Y	200 MHz	L4, L5, L8	Diode Residual	Yes
All control inputs low		Oscillator/Amplifier OFF (Q9 Off)		

4.78 Oscillator output is amplified by the wide-band feedback pair Q15, Q16, and goes to the RF Mixers through board pin 9.

4.79 Phase lock is accomplished by comparing the VCO output frequency with a 20 MHz output from the Master Oscillator in a phase detector, the DC output of which is applied to the Varicap through the loop amplifier, IC1, to bring the VCO into a phase locked relationship to the 20 MHz.

4.80 A portion of the VCO oscillator output is taken through C26 and amplified by the feedback pair Q17, Q18. This is applied to one side of the phase detector through auto transformer T4. The phase detector is made up of T2, T3, and the diodes CR16-CR19. 20 MHz input is amplified by Q23, Q24 and applied to the phase detector trans-

former T2. L14 aids in impedance matching. DC output from the center tap of T2 passes through loop amplifier, IC1, to the varicap, CR11.

4.81 If the loop goes out of lock, as when frequencies are switched, the loop gain drops to zero. This allows IC1 to operate as a low frequency Wien bridge oscillator. The frequency determining components are R59, C17 and R60, C28. The output of IC1, operating as an oscillator, applied to varicap CR11 causes the VCO to move through its range of frequencies. As it passes through the lock frequency, the loop closes, the high loop gain overrides the Wien bridge oscillator action and IC1 returns to its function as a loop amplifier.

4.82 RF Mixers and IF Amplifiers. A19

4.83 The fixed 430 MHz and the variable 460 to 510 MHz from the frequency synthesizer and the selected 60, 100, 160 or 200 MHz from the programmable phaselock loop VCO are mixed together, as required (see Table 4-1), in the two RF Mixer, BM1 and BM2. The Sig Gen Mixer is used only in the Signal Generator mode where it is necessary to shift the L.O. by 10 MHz to produce the dialed in output frequency. Figure 6-18.

4.84 The variable frequency, 460-509.9 MHz, and the fixed frequency, 430 MHz, are mixed in BM1 to produce the L.O. range of 30-69.999 MHz. For the L.O. range of 90-259.999 MHz, 430 MHz and either 60, 100, 160 or 200 MHz are mixed in BM2 to produce 230-370 MHz which is mixed with the variable frequency in BM1 to produce this L.O. output. The L.O. range of 260-439.999 MHz is produced by mixing the variable frequency and either 60, 100, or 160 MHz in BM1. The L.O. range of 460-509.999 MHz uses the variable frequency directly and no mixing takes place in this circuit. When the input to BM2 is 100 MHz this signal is routed through the 100 MHz bandpass amplifier, Q1, Q2.

4.85 Output from BM2 passes through the 370 MHz low pass, 230 MHz high pass filter to BM1. Output from BM1, in the 30-260 MHz range, passes through a 300 MHz low pass filter and an IF amplifier made up to two wide band pairs, Q8, Q9 and Q10, Q11, and then to the L.O. output, or to the signal mixer. The 260-440 MHz output of BM1 is routed through the 260 MHz high pass, 440 MHz low pass filter to IF amplifier, IC1, which has an automatic level control loop through IC2 around it. Output then is routed to the L.O. output or the Signal mixer, T1, CR33, CR34. 440-510 MHz is routed directly from the input to the L.O. output or the Signal mixer. A -12V input through board pin 7 controls Q5-Q7 to keep the Signal mixer turned off whenever the Model 312 Frequency Extender plug-in is used.

4.86 Switching is accomplished by the use of PIN diodes, which direct the signals into and out of the mixers and IF amplifier. Switching is controlled by the first two digits of the Frequency Selector switches through the Switching Logic,

A15, A16. The PIN diode switches are off when the diodes are back biased and on when they are forward biased. The ground path for the DC control of the PIN diodes is completed through RF chokes and they are isolated from the control circuit by series resistors. The RF is thus confined to the proper path through the PIN diodes. Either a positive or a negative voltage is applied to the PIN diodes and the way the diodes are connected determines whether the diodes are forward or back biased.

4.87 The control lines into the board are connected to terminal 1-7. Table 4-7 indicates the polarity of the voltage on the control lines + (positive) -(negative) and which mixers and amplifiers are turned on for the different ranges.

Table 4-7. Mixer, Filter and IF Amplifier Switching

Dial Fcy Range MHz	1	2	3	4	5	6	7	BM1	BM2	S.G.	Amplifiers			Filters		
											30-200 MHz	100 MHz Low Pass	200 MHz Band Pass	230-370 MHz Band Pass	260-440 MHz Band Pass	
30-90	*	-	-	-	-	-	-	ON	OFF	OFF	ON	OFF	ON	OFF	OFF	OFF
90-120	*	*	-	*	*	*	-	ON	ON	OFF	ON	OFF	ON	ON	OFF	OFF
120-180	*	*	*	*	*	*	-	ON	ON	OFF	ON	ON	ON	ON	OFF	OFF
180-220	*	*	*	*	*	*	-	ON	ON	OFF	ON	ON	ON	ON	OFF	OFF
220-450	*	*	*	*	*	*	-	ON	OFF	OFF	OFF	OFF	OFF	OFF	OFF	ON
450-520	-	-	-	-	-	-	-	OFF	OFF	OFF	OFF	OFF	OFF	OFF	OFF	OFF

* Indicates Signal Generator Mixer turned on

4.88 In the Signal Generator mode the Sig. Gen. Mixer is switched in and 10 MHz from the modulator, either modulated or CW, is mixed with the L.O. signal to generate the proper output frequency. Output from the Sig. Gen. Mixer is connected to the front panel SIGNAL GEN. OUT connector, A22J5 through the Output Attenuator, A20.

4.89 Switching Logic. A15

4.90 The circuits associated with the first and second digits of the Frequency Selector switches are controlled by this logic. This logic performs the following functions:

- (a) Selects tank circuit of 6-10 MHz VCO, pins 20 and 21.
- (b) Selects 430 MHz fixed L.O. frequency, PIN L.
- (c) Selects one of the Programmable Phase Lock loop VCO frequencies, pins 2, 9, F, 4.
- (d) Controls meter reversing relay according to whether mixing takes place on high side or low side, pin 18.
- (e) Selects 40 MHz mixing frequency instead of 42 MHz when dial frequency is set below 500 MHz, pin P.
- (f) Selects 42 MHz mixing frequency instead of 40 MHz when dial frequency is set to 500 MHz or above, pin R.

- (g) Selects 46 MHz for mixing in the 0-40 MHz generator and enables the audio and IF output when required, pin M.
- (h) Sets fifth decade count Preset on ÷N board, pins V, 19, 20.

4.91 When a first or second digit is dialed the connection labelled with that digit in Figure 6-14 is connected to ground (logic low). This is indicated by the complement bar over the numbers. The hundred MHz numbers are indicated by primed (2') digits.

4.92 VCO tank circuits are selected by a logic low output (ground closure) according to the pattern of Table 4-3. The meter relay control output, pin 18, is a ground closure when mixing is on the high side. Outputs are approximately +5V for the selection of a Programmable Phase Lock Loop frequency through pins 2, 9, F, 4, and for selection of 430 MHz (43 MHz enable) through pin L. Outputs are +20V through pins R (42 MHz), P (40 MHz) or M (I.F.) when any one of these is selected by the MHz frequency dial setting.

4.93 1 kHz to 4 MHz Mixer and 9.9 MHz filter. A7

4.94 These circuits accept a 46 to 50.99 MHz signal from the Balanced Mixer, pin 4 and a 46 MHz signal from the 46 MHz filter, pin 2. The two inputs are mixed to produce signals with frequencies in the 0 to 4 MHz range. As shown in Figure 6-6, the 46 MHz signal is amplified by Q1 before being applied to the mixer, T1, CR1, CR2. The 46-50.99 MHz signal is not amplified but applied directly to the center-tap of mixer transformer, T1.

4.95 The frequency that results from mixing is in the 0 to 4 MHz range. The signal is amplified by Q2, Q3, and delivered through emitter follower, Q4, to pin 10. When the front panel IF FREQUENCIES switch is placed in the 4 to 40 MHz position, a feedback path between Q2 and Q3 through R37 and R18 is removed by grounding the junction of the two resistors via pin 8. This increases the gain of the amplifier making the output approximately a square wave and, consequently, the 4 to 40 MHz harmonic content of the output signal is raised to a usable level.

4.96 100 kHz from the Reference Divider is connected to the input of the 9.9 MHz filter via pin 21. The first four harmonic amplifiers, Q5-Q8, are tuned to 3.3 MHz to select this frequency from the harmonics of the input 100 kHz square wave. The last harmonic amplifier, Q9, is tuned to 9.9 MHz to produce the required output at the proper level.

4.97 Second IF/Discriminator and Frequency Error Meter. A5, A4

4.98 These circuits are all on A5 except the meter which is on A4. For ease of dis-

cussion they have been divided in functional elements as follows:

1. Second Mixer, which includes an amplifier for the 10 MHz signal from the Preselector, an amplifier for the 9.9 MHz filter, and the mixer which produces a second IF which is nominally 100 kHz.
2. Discriminator/Frequency Error Detector, which delivers a voltage to the FREQUENCY meter when the second IF is not exactly 100 kHz.
3. Audio circuits, which demodulate the 100 kHz signal and deliver the AF signal to the audio amplifier on A16 and to either a Deviation Meter or an Oscilloscope plug-in.
4. Signal Level Detector which produces a disabling voltage to keep the Frequency Error Detector turned off until a sufficiently strong signal is received by the CE-5, and then enables the Frequency Error Detector and lights the SIGNAL LEVEL indicator when the signal level is high enough for satisfactory measurement.

4.99 Figure 4-3 is a block diagram of the Second IF and Discriminator circuits and Figure 6-4 is the schematic.

4.100 Second Mixer

4.101 The 10 MHz signal from the RF plug-in Preselector is amplified by tuned amplifier IC1 and applied to IC2. The 9.9 MHz signal from the Frequency Synthesizer is amplified by tuned amplifier Q1 and also applied to IC2. IC2 is connected as a mixer and its output is fed through a low pass filter to Q5 in the Frequency Error Detector.

4.102 Frequency Error Detector

4.103 The 100 kHz signal from IC2 is amplified by Q5 and applied to a squaring circuit Q6. The resulting 100 kHz square wave is differentiated, R35/C23, and the positive pulses are passed by CR1 to trigger a one-shot multivibrator, Q8, Q10. The multivibrator can operate only when the received signal is strong enough for the Signal Level Detector to furnish an enabling ground through Q4. The multivibrator output is a pulse with a width that is one-half the period of a 100 kHz square wave (5 microseconds) at the collector of Q10. This pulse width remains at 5 microseconds regardless of meter reading. The width between pulses, however, depends on the interval between input pulses (pulse frequency) and therefore will be longer for a lower frequency and shorter for a higher frequency. The duty cycle will therefore vary with frequency, and will be 50% only at 100 kHz. The outputs from the

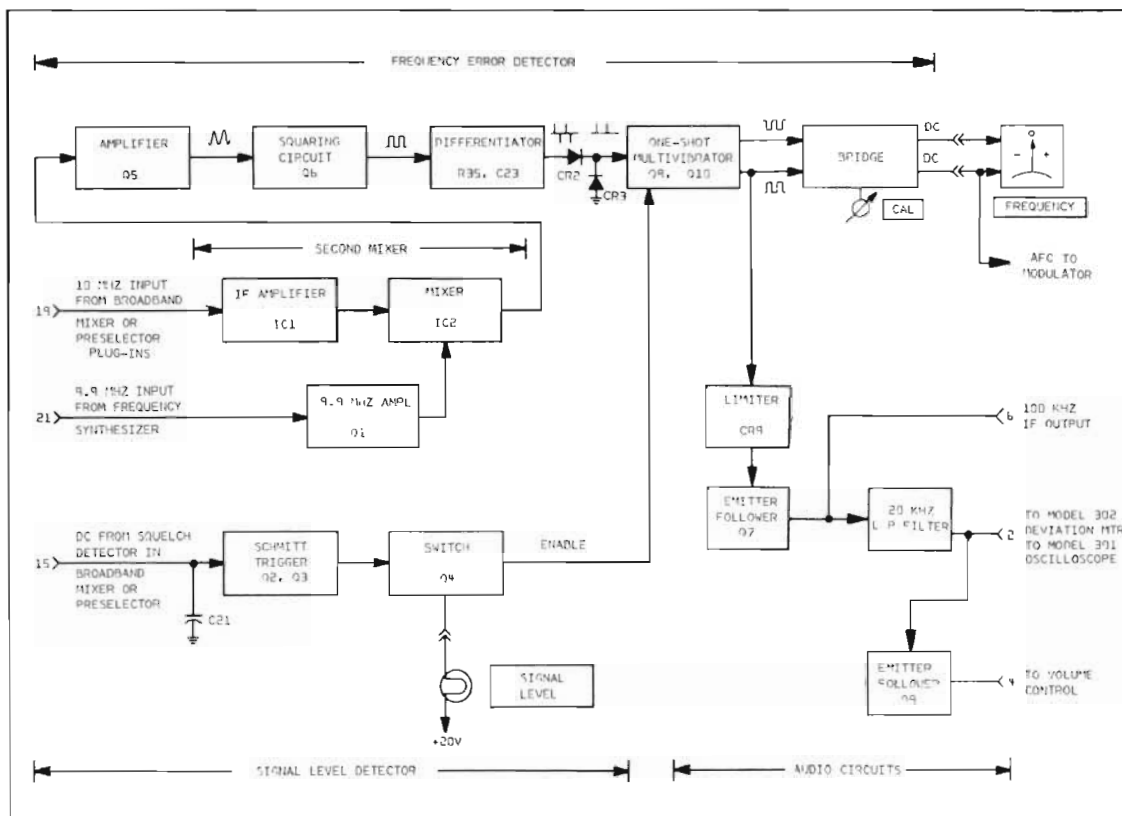

Figure 4-3. Second IF and Discriminator Circuits, Simplified Block Diagram

collectors of Q8 and Q10 are fed to a meter bridge circuit.

4.104 The bridge circuit includes the FREQUENCY meter on the front panel. A simplified schematic of the metering bridge circuit is shown in Figure 4-4. In this figure transistors Q8 and Q10 are shown as switches, one of which is always off when the other one is on.

4.105 For more than half the frequencies that can be selected, the L.O. frequency is 10 MHz below the dialed in frequency, Table 4-1. When this is true, relay A4K1 on the Frequency Meter board, Figure 6-3, is de-energized and the input from the Q10 side of the Frequency-Error Detector is applied to the positive side of the meter.

4.106 For the remainder of the frequencies A4K1 is energized and the input from the Q8 side of the Frequency Error Detector is applied to the positive terminal of the meter. Regardless of whether the relay is energized or de-energized, the action of the circuit is the same.

4.107 For the conditions shown in Figure 4-4,

the switch that is on, Q10, causes the voltage at point Y to drop to a minimum (about .6 volts) and the switch that is off permits the voltage at point X to rise to a maximum (about 20 volts). The lower part of Figure 4-4 shows the waveforms at point X and Y. The time a switch is on equals the time it is off only when the input frequency is exactly 100 kHz; that is, when the pulse durations equal the times between pulses and represent a 50% duty cycle.

4.108 When the pulsed signals at X and Y have a 50% duty cycle, the L/C combinations L11/C31 and L12/C35, which are averaging networks, apply the same potential to both sides of the meter.

4.109 When the input signal frequency is not exactly 100 kHz, but higher or lower, one of the switches is on a shorter time than it is off. Therefore, the other switch is on longer than it is off. Neither the duty cycle of the waveform at X, nor the one at Y is 50% and, as a result, the average voltages at these points are not equal. A difference of potential exists across the meter and the meter needle deflects. Since needle deflection is proportional to the difference in potential across the meter and since this potential is proportional to the difference between 100 kHz and the frequency of the input signal, the meter dial is calibrated directly in kHz.

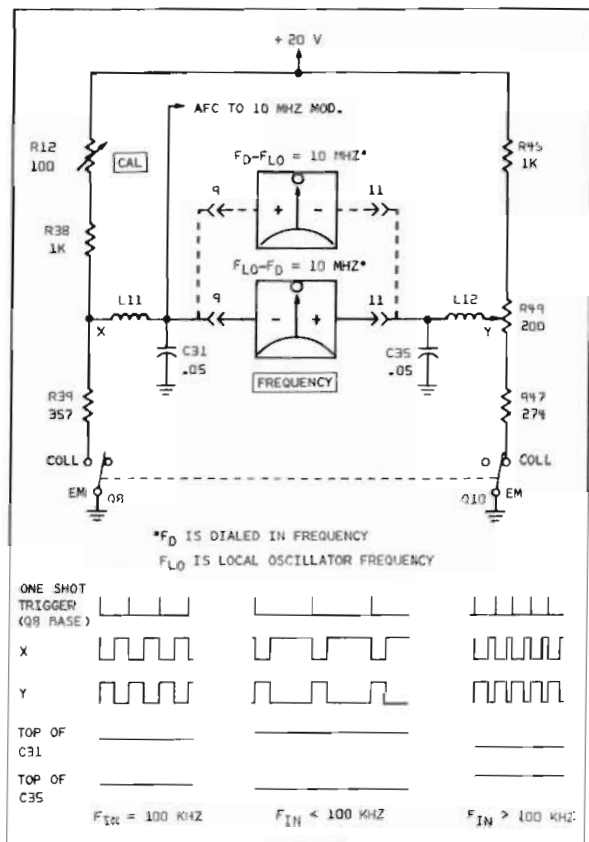

Figure 4-4. Frequency Meter Bridge Circuit

4.110 Adjustment has been provided by R49 which centers the range of the front panel CAL control A22R12. In addition, each of the three meter ranges, 0 to 1.5 kHz, 0 to 5 kHz, and 0 to 15 kHz, can be separately adjusted by one of three potentiometers A4R4, A4R5, A4R6.

4.111 The three meter ranges are selected by means of the lever switch directly under the FREQUENCY meter on the front panel. A pair of diodes A4CR1, A4CR2 provide overload protection for the meter.

4.112 Meter-range selection is possible only when the function switch is in the MONITOR position and the CE-5 is being used as a Communications Monitor. When the function switch is in FM, AM/CW, or CAL, no range selection is possible. In FM the meter input always indicates in the 0 to 5 kHz range. In AM/CW and in CAL, only the 0 to 1.5 kHz range is effective.

4.113 The voltage at the junction of L12 and C35 is also used as an Automatic Frequency control (AFC) voltage. For this purpose it is applied via pin 9 and the front panel function switch A22S8-D10 to the Varicap in the oscillator circuit

on the Modulator Board.

4.114 Audio Circuits

4.115 In the explanation of the metering circuit, mention was made of the manner in which the voltages appearing across the averaging network relate to the duty cycles of the pulses signals and cause meter needle deflection. If the incoming signal is frequency-modulated the average voltages at points X and Y also vary at the modulation rate. This variation does not affect the needle deflection because of the filtering action of the averaging circuits (L11/C31, L12/C35).

4.116 The modulation which is still present at the collector of Q10, (100 kHz ± error + modulation) is fed through an isolation diode, CR9, to the audio circuits consisting of emitter follower, Q7, a low pass filter, and another emitter follower, Q9. The audio signal passes to the volume control through pin 4. The audio to the Deviation Meter or Oscilloscope passes through Q7, the low pass filter to pin 2. The output at pin 6 is taken off at a point in the signal path where the 100 kHz component is still present. This output is made available at the front panel 100 kHz IF output, A22J2. A counter connected to this connector will read 100 kHz ± the frequency error to the accuracy of the counter ± the monitor accuracy.

4.117 Signal Level Detector

4.118 The RF plug-in Preselectors incorporate a squelch circuit which produces a DC voltage that is proportional to received signal strength. This DC voltage is applied to a Schmitt Trigger consisting of Q2 and Q3, which is set to fire when the signal output of the First IF Amplifier in the Preselector is approximately 60 millivolts. When the Schmitt Trigger fires, it turns switching transistor Q4 on, which enables the Frequency Error Detector and also lights the SIGNAL LEVEL indicator to announce that the signal is strong enough for reliable measurement. The Schmitt Trigger remains in the fired state as long as the signal level is above the critical level.

SIGNAL GENERATING CIRCUITS

4.119 Signals in the range of 20 MHz to 520 MHz are generated by mixing a CW or modulated CW 10 MHz signal, with the Frequency Synthesizer output (L.O. Signal). This was noted in paragraphs 4.22 and 4.88. The signal thus generated has the same frequency as is shown by the Frequency Selector dial. The circuits used are the same as in the Receive mode with the exception of the modulator circuit. The generation of IF output frequencies was discussed in paragraphs 4.94 and 4.95.

4.120 10 MHz Modulator. A18

4.121 The purpose of this circuit is to frequency modulate or amplitude modulate the 10 MHz

input to the Signal Generator Mixer. This modulation signal is derived from a Frequency Synthesizer 1 kHz source, or from an external source with a frequency between 60 Hz and 20 kHz. Figure 6-17 is the schematic of the 10 MHz Modulator.

4.122 In the FM mode the 10 MHz signal is generated by voltage controlled oscillator Q3. The tuned circuit of the oscillator consists of C10, C12, L2, C14, C15, and Varicap, CR1. The capacitance of the Varicap varies with the voltage across it. The frequency is set to exactly 10 MHz with the FM CAL control. The FREQUENCY meter indicates "0" when the adjustment to this frequency is correct. The FM CAL control adjusts the DC voltage applied to Varicap, CR1, in the frequency determining portion of the oscillator circuit through pin H. The oscillator is kept at 10 MHz by an AFC voltage from the Frequency Error Detector, A5, via the front panel function switch, A22S8-D2 through pin J.

4.123 The modulating signal is applied to CR1 through pin K, R1, C1, L1. This voltage causes the Varicap capacitance to change with the modulation frequency and thus controls the frequency of the oscillator to produce frequency modulation.

4.124 The 1 kHz modulating signal from the Frequency Synthesizer is connected through pin B to IC1A, connected as a 1 kHz bandpass filter. Output from IC1A goes to amplifier, IC1B, through FET transistor switch, Q2. External modulating signals from the front panel EXT MOD connector A22J4 are also connected to the input of IC1B. Either the internal or external modulating signal or both if desired is thus amplified by IC1B and the output goes through pin 4 to MOD ADJ control, A22R5A-1. From there the signal comes back to pin K as the modulating voltage to the Varicap, CR1, or to the amplitude modulator Q10 through amplifier Q13. In this way either internal or external modulation is controlled by the front panel MOD ADJ control.

4.125 The output of IC1A is attenuated and then connected to emitter follower, Q1, from which it is connected to the 1 kHz OUT connector A22J3, making 1 kHz available at the front panel at all times.

4.126 The 10 MHz VCO oscillator, Q3, and amplifier, Q4, are enabled by +20V connected through the FUNCTION switch, A22S8-B2, when it is set to the FM position through pin M.

4.127 Modulated 10 MHz goes through tuned amplifier Q5, through voltage controlled attenuator, R77, CR2, through emitter follower Q8 to tuned output amplifier, Q9. Output from Q9 is tapped off between C39, C40, (for impedance matching) passes through the pad R54-R56 to pin T and then to the Signal Generator Mixer on board A19. An output from Q9 also goes to emitter follower Q14 and from Q14 to the Preselector via pin U. From

the Preselector it is connected to the Second IF/Discriminator A5. FM CAL, A22R5B is used to adjust the VCO to 10 MHz. Another output is coupled out through emitter follower Q15 to average detector CR7, R69, R70. This detector responds to carrier level but not to the modulation on the signal. Detector output is filtered by C41, amplified by IC2 and connected to the voltage controlled attenuator, R77, CR2, to provide automatic level control for the 10 MHz output.

4.128 Internal 1 kHz or external modulating signals are also connected, through pin K, to Q13. When the FUNCTION switch is in the FM position +20V is also connected to CR6 which causes Q13 to be biased off and allows Q10 to act only as a constant current source in the emitter of Q9. When the FUNCTION switch is placed in the AM/CW position, VCO oscillator and amplifier Q3, Q4, is disabled, and Q13 is enabled as a buffer for the modulation signal. At the same time the 10 MHz filter on the Master Oscillator/Divider/Filter circuit, A6, is turned on to supply a 10 MHz signal to the 10 MHz modulator through pin P to the input of Q5. This signal is connected to Voltage Controlled Attenuator, R77, CR2, through Q8 to Q9 where it is amplitude modulated by Q10 which is driven by the modulating signal through Q13. The Amplitude Modulated 10 MHz signal now goes through pin T to RF mixer, A19, via the RF attenuator, and thus not only shifts the L.O. signal the required 10 MHz but also amplitude modulates the output signal.

4.129 In CW operation the 10 MHz input through pin P is amplified and passed out to the Signal Generator mixer through pin T. INT MOD must be switched off to prevent 1 kHz modulation. Also all signals must be disconnected from EXT MOD connector, A22J4.

4.130 In the FM and AM/CW signal generating modes, the Modulator output is fed through the signal generator attenuator to the A19 Sig Gen Mixer. The attenuator is calibrated in terms of voltage level at the output of a 20 dB fixed attenuator connected to the SIGNAL GEN OUT connector. Without adjustment, slightly different output voltages would be produced by the Signal Generator Mixer for each of the CE-5 frequency bands, for a given 10 MHz input signal. Therefore, the Modulator output level must be slightly different for each of these bands. To accomplish this a different bias is applied to IC2, depending on which fixed L.O. frequencies are used in the RF mixers.

4.131 Logic switching outputs from the mixer and IF switching circuit, A16 are used to switch in the proper adjustable resistor, R37, R41, R49, R62 through transistor switches Q6, Q7, Q11, Q12. These resistors control the bias on IC2 and thus set the output level for each band of frequencies.

4.132 In the CAL mode of the FUNCTION switch A22S8, the 10 MHz from the Master

Oscillator/Divider/Filter passes through the circuit as in the CW mode and goes out pin U to the last IF stages of the Preselector and then to the second IF/Discriminator circuit, A5, where it is used as the standard to which the FREQUENCY meter is calibrated. Front panel CAL control, A22R12, center control on FUNCTION switch, is used to balance the error detector bridge so that the FREQUENCY meter reads zero when this accurately generated 10 MHz frequency is applied.

4.133 Output Attenuator. A20

4.134 Level to the output connector, in the Signal Generator mode, is controlled in 20 dB (X10) steps by the switchable attenuator. Two identical 20 dB attenuators are individually switched in or out in proper combination to provide these steps. PIN diode switches CR1-CR8 (Figure 6-25) are controlled by the front panel X1-X10-X100 switch, A22S12. -12V to both attenuators switches both out of the circuit for 0 dB attenuation (X100). -12V to one and +20V to the other switches one in for 20 dB (X10), and +20V to both switches both in for 40 dB attenuation (X1). Fine adjustment, .1-1.0 microvolts, is accomplished by a variable attenuator, Figure 6-25, adjusted by front panel MICROVOLTS control, A22R6. Output from the Signal Mixer is amplified by IC1 and applied to a PIN diode variable attenuator made up of diodes CR9-CR12. CR9, CR12 provide shunt attenuation and CR10, CR11 are series attenuators. Because of the non-linear attenuation characteristic of the PIN diodes control current is furnished by a linearizer circuit made up of IC2, Q1-Q5, which is adjusted to compensate for the non-linearity of the PIN diodes. The linearizer is controlled by the MICROVOLTS variable control on the front panel. Output from the PIN diode variable attenuator passes to the Step Attenuator and then to the front panel output connector through protective fuse, F1.

4.135 Power Supplies

4.136 The power supply circuits and components are mounted on two circuit boards, the center plate and the rear panel. The transformer and main fuse are mounted on the rear panel, A23. The rectifiers, filter capacitors and DC fuses are mounted on the circuit board, A13, which is attached to the rear panel. The Regulator control circuits are contained in, A12, while the series regulator transistors are mounted on the center plate, A25. See Figures 6-11, 6-12, 6-21, and 6-23.

4.137 Three separate secondary windings on the transformers A23T1 supply AC power to the three bridge rectifiers on A13. Each rectifier output is separately fused and is filtered by a single capacitor. Rectifier outputs go to the regulator A12. A fourth secondary winding supplies power to the dial and decimal point lights. A second transformer, A23T2, supplies AC power to the crystal oven heater element. This transformer reduces line noise pickup to the crystal oscillator and also permits changing the AC input voltage from 115VAC

to 230VAC (by changing the jumpers) without changing the crystal oven.

4.138 The 20 volt regulator is a conventional series regulator type. The differential amplifier is A121C1 and the reference voltage is set by A12CR2. A12Q1 is a current amplifier which feeds the series regulator, A25Q1, mounted on the center plate. Overcurrent protection is provided by sensing resistor A12R4 and control transistor A12Q2.

4.139 The -12 volt regulator operates in the same manner as the 20 volt regulator except that the positive side is connected to ground.

4.140 In the 5 volt regulator the supply for the zener reference, A12CR4, is taken from the 20 volt output, A12Q5 is the differential amplifier. The remainder of the circuit corresponds to the 20 volt regulator. An additional zener diode, A12CR5, prevents voltage spikes from reaching the Integrated Circuits, which are powered by the 5 volt supply.

4.141 Decimal Point Lights and Flasher A22

4.142 The position of the decimal point light is controlled by A22S9 and A22S1E. The decimal point is shifted one place to the left when A22S1 is in the IF position and A22S9 is in the 0-4 MHz position.

4.143 Switches A22S1 and A22S2, the first and second Frequency digits are wired so that if they are set to a frequency outside the range of the instrument the flasher, A22S13, will be cut in and the dial lights will flash on and off. Also the Unlocked light may come on. Any setting of the RF range below 20.000 MHz or above 519.999 MHz will cause the lights to flash. In the IF range any setting above 3.9999 MHz in the 0-4 MHz range or above 39.999 MHz in the 4-40 MHz range will also cause the lights to flash.

4.144 The input AC from power plug, P1, is filtered by A23L1-L2 and A23C3-C4. This filtered power source is then used to drive both the power transformer, A23T1, and the Crystal Oven through transformer, A23T2.

NOTE

For 230 volt operation jumper wires on the two transformers must be changed. Jumpers on A23T1 pins 1-2 and 3-4 must be removed and pins 2-3 jumpered. On transformer A23T2 jumper wires on pins 1-2 and 3-4 must be removed and pins 2-3 jumpered.

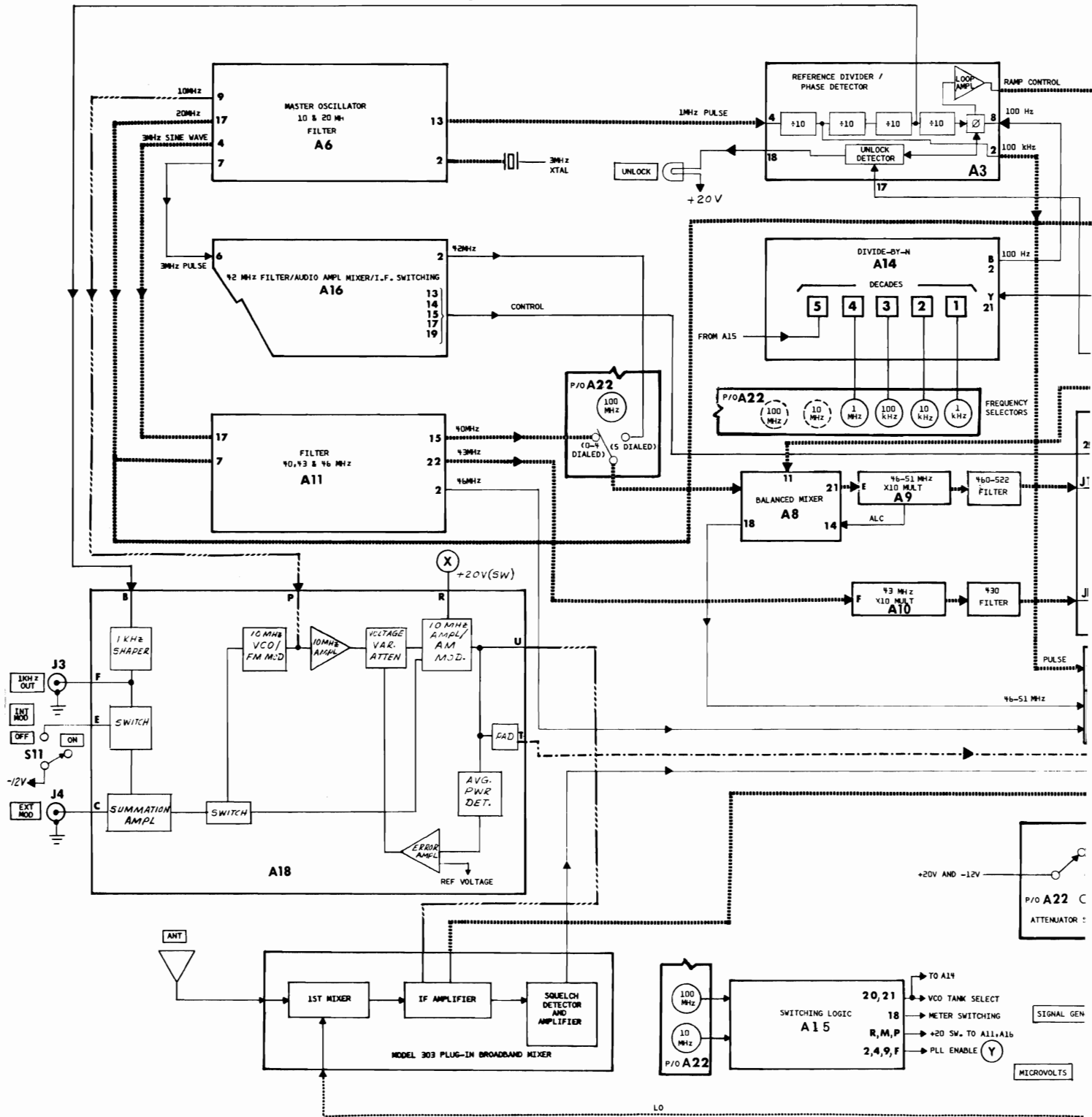

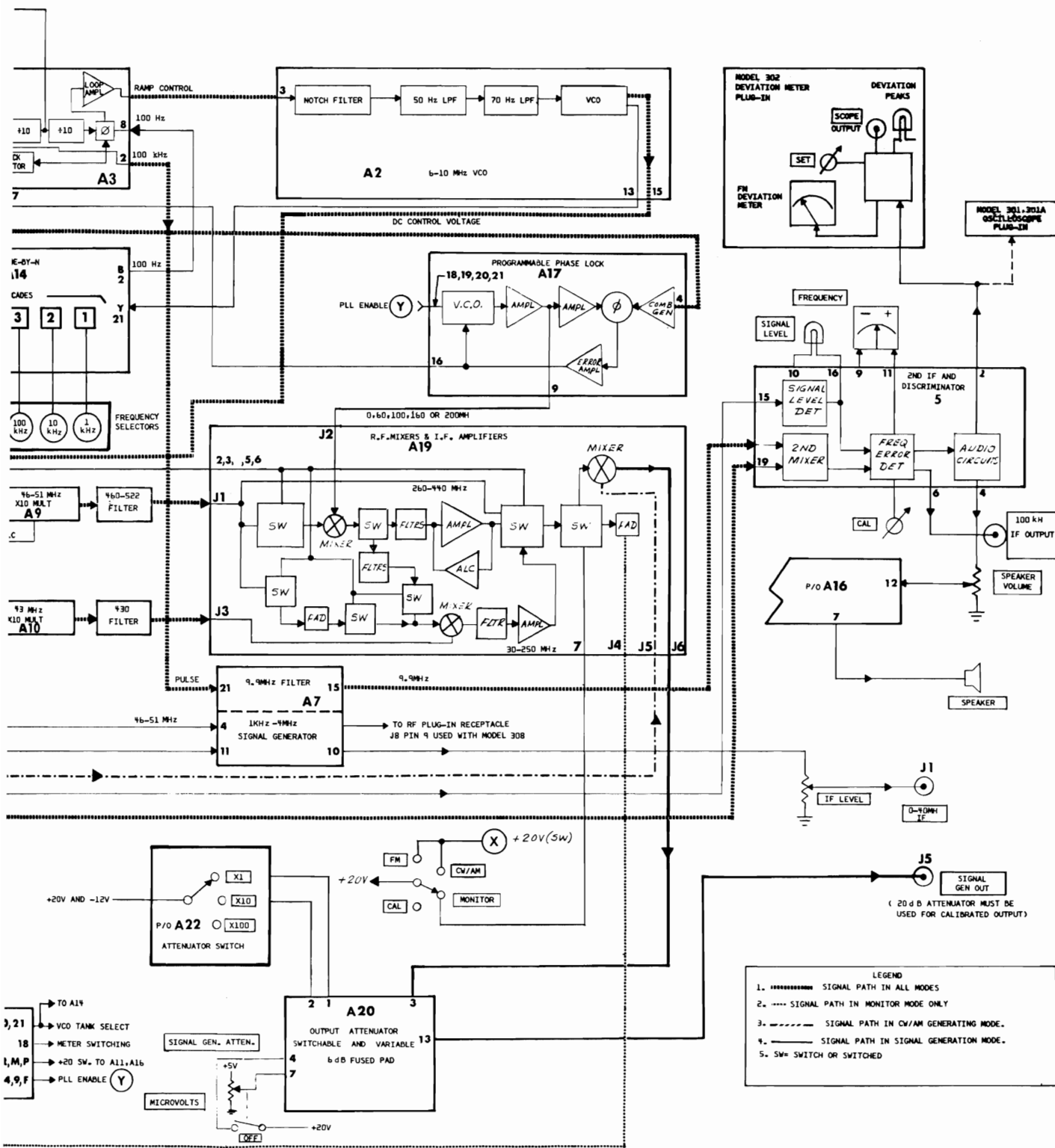

LEGEND

1. SIGNAL PATH IN ALL MODES
2. ---- SIGNAL PATH IN MONITOR MODE ONLY
3. - - - - SIGNAL PATH IN CW/AM GENERATING MODE.
4. ——— SIGNAL PATH IN SIGNAL GENERATION MODE.
5. SW= SWITCH OR SWITCHED

Figure 4-5. Model CE-5 Overall Block Diagram

4-15/4-16

October 1976

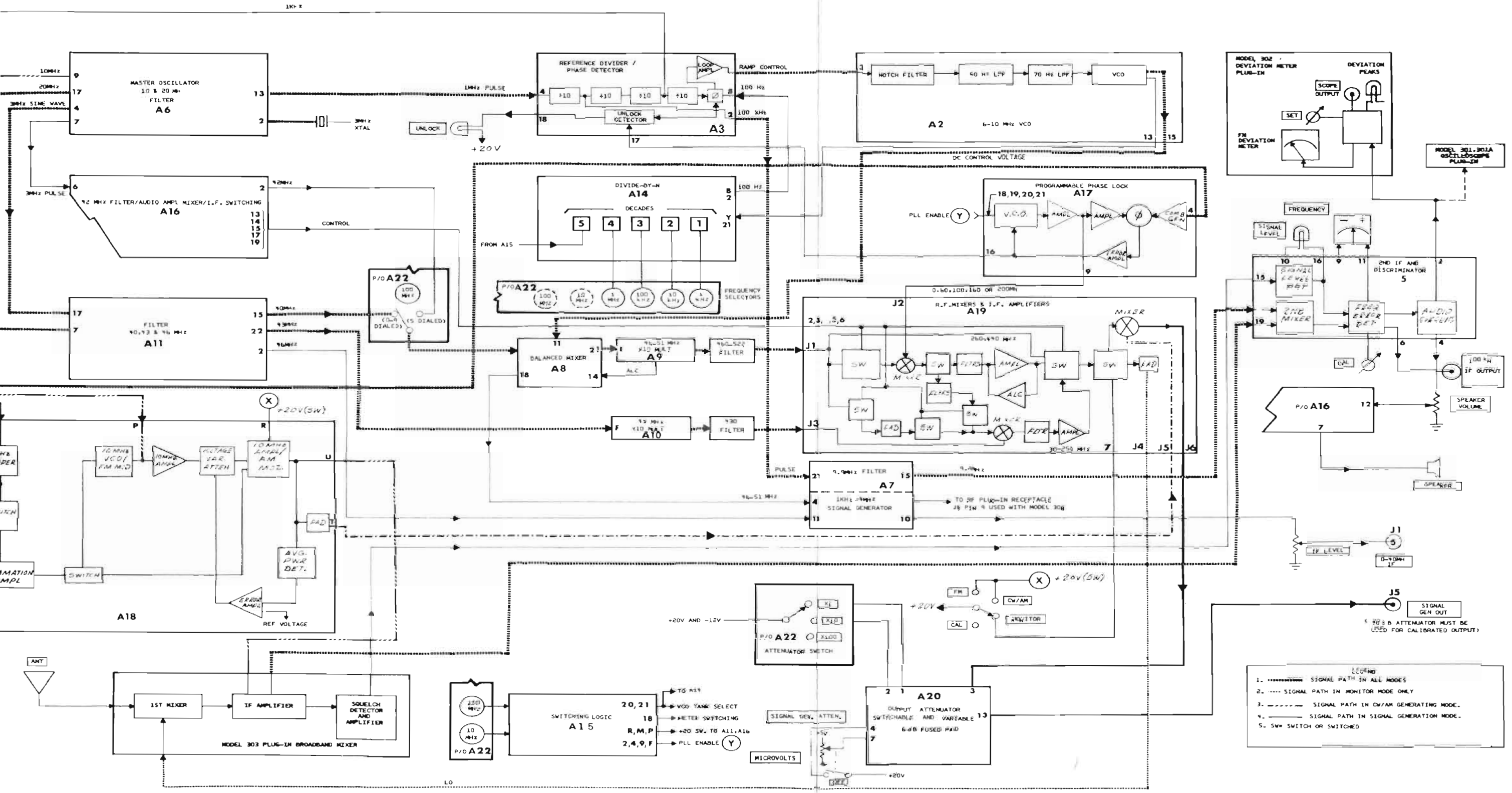

Figure 4-5. Model CE-5 Overall Block Diagram
4-15/4-16

SECTION 5 MAINTENANCE

GENERAL INFORMATION

5.01 This section is divided into two major sub-sections: "Adjustments", and "Troubleshooting". It is recommended that for adjustments other than those described, the faulty subassembly or the entire instrument be returned to the Cushman Electronics Customer Service Department for calibration and alignment. Refer to paragraph 2.12.

5.02 In the following discussions it is assumed that the operator is familiar with the operating procedures described in Section 3.

5.03 The instrument should be warmed up for a short time before any adjustment is attempted.

ACCESS AND PARTS LOCATION

5.04 Components in the top part of the instrument can be reached by removing the side covers. Each cover is held by six screws; the speaker leads must be disconnected before the right-hand cover can be removed completely. When the instrument is placed on its back the bottom cover can be removed. With this cover off the plug-in printed circuit boards are accessible.

5.05 Figure 5-1 shows the location of the circuit boards in the bottom of the instrument. The same drawing is screened on the inside of the bottom

panel.

5.06 Location of components on the circuit boards is given on the component identification drawings which are placed on the inside sheet of the schematic diagrams to which they apply. The adjustable components may be located from these drawings.

5.07 The fuses of the three regulated power supplies are on the rectifier board which is mounted on the inside of the rear panel near the upper left hand corner. The +20V fuse is nearest the outside, the -12V fuse is in the center and the +5V fuse is nearest to the center plate. The 0.2A slo-blo fuse for the oscilloscope plug-in is mounted above the left hand plug-in jack A24J17. The main fuse is mounted on the rear panel near the power cord and is accessible from the outside of the instrument.

5.08 A board extractor and an extender board are furnished. They are inserted in a compartment in the bottom of the instrument. Before removing or inserting a circuit board, be sure to turn off the power to the instrument.

5.09 All adjustments accessible through the chassis have a label next to the access hole. The assemblies mounted on the center plate have a label affixed. The label for the assembly on the right hand side of the center plate is directly behind the assembly on the left hand side.

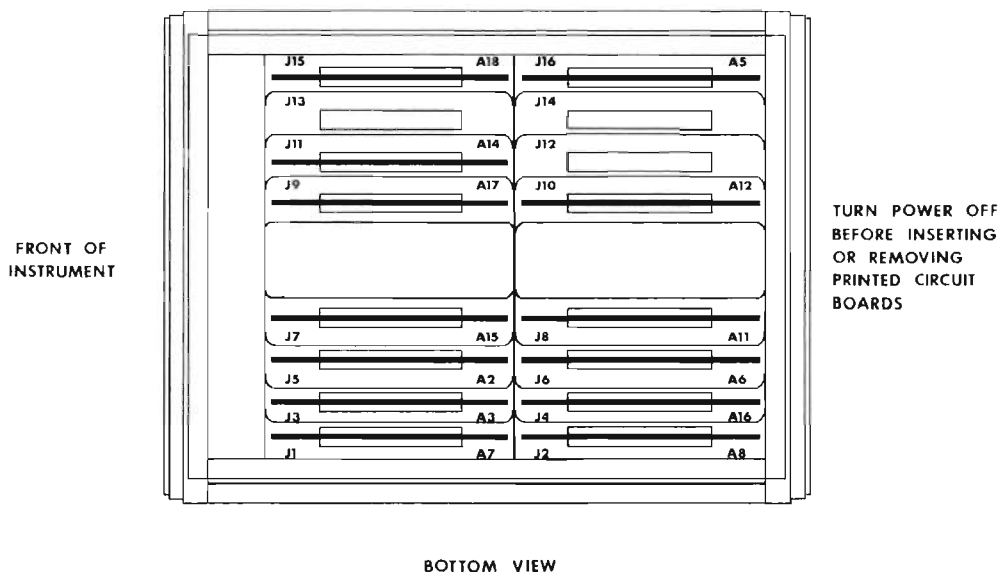

Figure 5-1. Circuit Board Location.

ADJUSTMENTS

5.10 POWER SUPPLY VOLTAGES

5.11 Equipment required:

Digital Multimeter Dana 4300 or equivalent

NOTE

The regulated power supplies are set to within 0.5% of rated output voltage at the factory. They should not be adjusted unless a voltmeter with the specified accuracy is available.

5.12 Stand the instrument on its back and remove the bottom cover. Locate the Power Supply Regulator board, A12, and raise it up on board extender. (Paragraph 5.08). See Figure 6-11.

- a. Measure the +20V output at board pin 5. Adjust R7 if necessary.
- b. Measure the +5V output at board pin 15. Adjust R14 if necessary. The +20V supply must be checked and adjusted before making any adjustment to the +5V output.
- c. Measure the -12V output at board pin 19. Adjust R21 if necessary. Replace circuit board in chassis.

5.13 MASTER OSCILLATOR FREQUENCY

5.14 Equipment required: Counter having a time base accuracy of 1 part in 10^7 or better. Dana 8100 or equivalent.

5.15 Stand the CE-5 on its back, remove the bottom cover and elevate the A16 board on the extender. Turn on the instrument and let the crystal oven warm up for at least 30 minutes.

NOTE

If the CE-5 is left connected to the AC power the crystal oven will be on even though the instrument power is turned off and will be ready for calibration a few seconds after the instrument is turned on.

5.16 After the crystal oven is thoroughly warmed up, turn on the CE-5 and proceed as follows:

- a. Turn the 100 MHz dial (first dial on left) of the Frequency Selectors to 5. (This turns on the 42 MHz harmonic amplifier).
- b. Connect the counter to board pin 2 on A16. Use a X1 oscilloscope probe connected to the counter to make the con-

nection. Counter should read 42 MHz \pm 4 Hz. If necessary adjust A25C1 (just below crystal oven on right lower rear of center plate) for this reading. Replace A16.

CAUTION

115V (or 230V) AC is present in this area. Use a long plastic tool to make this adjustment.

5.17 FREQUENCY METER ZERO ADJUST

5.18 Set the Function switch to CAL and proceed as follows:

- a. With power off mechanically zero the needle on the FREQUENCY meter. (Adjustment accessible through small hole directly below meter).
- b. Center the white line (set straight up) of the CAL CONTROL (inner control concentric with the Function switch).
- c. Adjust FREQ. METER COARSE CAL ADJUST (A5R49) until the FREQUENCY meter reads zero. (Adjustment located on right side of chassis toward rear. Use plastic adjusting tool.)

5.19 MODULATOR CENTER FREQUENCY

5.20 After making above adjustment, with meter left setting on zero, proceed as follows:

- a. Set Function switch to FM.
- b. Set the white line on the FM CAL control (concentric with MOD ADJ control) so that it points straight up.
- c. Turn MOD ADJ control fully counter-clockwise.
- d. Stand CE-5 on its back and locate the A18 board. Adjust L2 for a zero reading on the FREQUENCY meter. See component identification, Figure 6-17. (L2 is accessible without raising board on extender, a little below middle of board.)

5.21 FREQUENCY METER RANGE

5.22 The IF output of the CE-5 may be used to calibrate the FREQUENCY meter. Since the calibration depends on the difference between two synthesizer generated frequencies the calibration is accurate to the degree of the synthesizer accuracy.

- a. Use a Broadband plug-in or a Pre-selector with a Wide Band mixer set to the Wide Band mode.

- b. Set Function switch to CAL and zero the meter with the CAL, control concentric with the Function switch.
- c. Set the Function switch to MONITOR.
- d. Set the IF FREQUENCIES switch to 4-40 MHz.
- e. Set the Frequency Selector dial to IF 09.999 MHz.
- f. Connect a coaxial cable with an adapter from the IF FREQUENCIES OUTPUT to the ANT. connector on the RF plug-in.
- g. Turn the IF LEVEL control fully clockwise.
- h. Set the FREQUENCY meter range switch to ± 1.5 kHz.
- i. The meter should read -1.0 kHz on the lower scale. If not adjust R6 on the printed circuit board mounted on the back of the FREQUENCY meter (upper control). (Access to control through left hand opening with plug-in removed.)
- j. Set meter range switch to ± 5 kHz and dial in IF 09.995 MHz.
- k. Meter should read -5.0 kHz on upper scale. If not adjust R4, middle control on the board mounted on the meter.
- l. Set the meter range switch to ± 15 kHz and dial in IF 09.985.
- m. Meter should read -15 kHz on the lower scale. If not adjust R2, lower control.
- n. To verify the positive side of the scale dial in IF 10.001, IF 10.005, IF 10.015 for the ± 1.5 kHz, ± 5 kHz, ± 15 kHz ranges respectively.

5.23 20 dB FIXED ATTENUATOR

5.24 The 20 dB attenuator is used to prevent damage to the CE-5 in case the transmitter of a transceiver to which the CE-5 is connected is accidentally keyed. In case this occurs the fuse will be blown and possibly the input resistor, R3, (Figure 6-24) may be damaged. Before calibrating the CE-5 Signal Generator output level, or in case damage is suspected the attenuator should be checked.

- a. Use an RF source calibrated in dB, HP608 or equivalent and an RF Voltmeter with a 50 Ω probe, Boonton 91D or equivalent. Measure the attenuation of the attenuator. It should be 20 dB \pm 1/2 dB.

(If an RF voltmeter is not available use a metered receiver as an indicator and the Signal Generator (HP 608) attenuator to make the measurement. Make certain receiver is not saturated.)

- b. If repair is necessary use only the fuses furnished with the instrument or order from Cushman Electronics. (Cushman part number 7040-0018 in packages of 10 fuses.) Use only 5% resistors of values given in Figure 6-24.

5.25 SIGNAL GENERATOR OUTPUT LEVEL

5.26 Test equipment required: RF Signal Generator with 50 Ω output, HP 608 or equivalent. Receiver capable of operating at the frequencies to be calibrated, having a signal strength meter. (A receiver without a meter, with an AC VTVM connected to the output of the first or second IF stage may be substituted.) The receiver is used as a transfer device after the level has been set by the signal generator.

- a. Check and adjust, if necessary, at the following frequencies:

FREQ RANGE	CALIBRATION FREQUENCY	ADJUSTMENT
20-80 MHz	35 MHz	A18R37
80-250 MHz	165 MHz	A18R41
250-450 MHz	350 MHz	A18R49
450-520 MHz	470 MHz	A18R62

The adjustments are on the 10 MHz modulator board, accessible when bottom cover is removed. Adjustment controls are in order from the inside of the board toward the outer end with R37 being the inner control and R62 the outer.

- b. Set the CE-5 to MONITOR and dial in the calibration frequency given in step a. Connect the signal generator to a Broad-band mixer plug-in in the CE-5 and very carefully tune the signal generator to the calibration frequency as indicated on the CE-5 FREQUENCY meter. Do not disturb the signal generator frequency setting until after measurement has been made.
- c. Connect the signal generator to the receiver through the 20 dB attenuator and set the signal generator for 10 μ volts output. The attenuator will reduce this level by 10:1 so there will be 1 μ volt at the input of the receiver. Note the reading on the signal strength meter. (Make certain the receiver is not saturated.)
- d. Remove the input end of the 20 dB attenuator from the signal generator and connect it to the SIGNAL GEN OUT on the CE-5.

- e. Turn the CE-5 Function switch to SIG GEN AM/CW. Make certain the INT MOD switch is off and nothing is connected to EXT MOD. Set CE-5 step attenuator to X1 and MICROVOLTS to 1.0 μ volt.
- f. Observe the reading on the signal strength meter of the receiver. This reading must be within ± 2 dB of the reading noted in step c. If this reading is not obtained refer to step a. for adjustment control and location. Adjust level until it is within ± 2 dB of reading noted in c.
- g. If no adjustment is required, or after adjustment is made, repeat procedure of steps b. through f. for the other calibration frequencies listed in step a.
- h. After adjustment the signal level should be checked with the Function switch in the FM position (no modulation). Carefully set FM CAL to frequency. Level should be within 1dB of levels noted for CW operation.

TROUBLESHOOTING

- 5.27 In all modes of operation the phase lock loops of the main frequency synthesizer and the Programmable Phase Lock Loop circuits are an important part of the instrument. When these loops are not phase locked the proper frequencies are not synthesized.
- 5.28 The UNLOCK indicator shows the condition of this circuit. When the two 100 Hz signals to the phase detector on A3 are phase locked (or both absent), and there is no Programmable Phase Lock Loop error signal at the Unlock Detector circuit on A3, the UNLOCK indicator will not light.
- 5.29 If the UNLOCK lamp is lighted, it can be determined which of the two loops is unlocked by removing the Programmable Phase Lock Loop board, A17.
- 5.30 After removing board A17, turn the instrument on again and note the condition of the UNLOCK indicator. If the light does not come on now, the trouble may be in the crystal oscillator oven assembly, the Master Oscillator/Divider/Filter board, A6, or the Programmable Phase Lock Loop circuits, A17.
- 5.31 If the UNLOCK light remains on, the trouble is probably in the main frequency synthesizer loop consisting of the 6-10 MHz VCO, A2, the Reference Divider/Phase Detector, A3, or the Divide-by-N counter, A14.
- 5.32 To further narrow down the area of trouble a high frequency oscilloscope such as the HP 180 series, or equivalent, or a frequency counter such as the Dana 8100 series or equivalent may be used for signal tracing. The frequencies and voltages into and out of the circuit boards are given in many cases on the schematic diagrams.
- 5.33 Before extensive checking of circuits the power supply regulated outputs should be checked, paragraph 5.10-5.12. Performing the other adjustments may help to localize the trouble. For instance, in the Signal Generator output adjustment, if the proper level may be obtained in the CW position of the Function switch but not in the FM position the trouble is most likely in the 10 MHz Modulator board, A18.
- 5.34 In the Troubleshooting Chart, Table 5-1, some front panel indications of possible troubles are listed with the probable cause and the circuits or boards that should be checked. In troubleshooting, the Block Diagram, Figure 4-5, can be used to trace signals through the instrument to the appropriate board. Then the board schematic, with its indicated frequencies and levels, can be used to reduce the problem to the component level.
- 5.35 If another CE-5 is available the quickest way to locate trouble is by board substitution. When the faulty board is located it may be returned to the factory Customer Service Department for repair (paragraph 2.12 and 2.13) if desired.

NOTE

Always turn off power in the instrument when removing or installing circuit boards.

Table 5-1. TROUBLESHOOTING CHART

TROUBLE	POSSIBLE CAUSE	CHECK
1. CE-5 inoperative	Main fuse	Check and replace if necessary
2. CE-5 inoperative except oven light	Fuse on Power Supply Rectifier Board	Check and replace if necessary.
3. FREQUENCY meter pinned SIGNAL LEVEL light on	No -12 VDC	Check -12V fuse on Rectifier Board
4. No RF signal reception, Signal Generation OK	RF Plug-in	Check for signal through plug-in, check squelch output
5. No Signal Generation, reception OK, CAL OK	20 dB Attenuator fuse Signal Mixer fuse	Check 20 dB attenuator Check fuse A20F1
6. No Signal Generation FM or CW, no CAL, reception OK	10 MHz Modulator	Check 10 MHz outputs from 10 MHz Modulator Board A18
7. No reception, no signal generation, CAL OK	Failed board in path of LO signal	Check all bands following Table 4-1 to see if programmable Phase Lock or 43 MHz x 10 multiplier may be at fault. Check output of other boards in LO path.
8. No CW Signal Generation FM Sig. Gen OK	No 10 MHz output from Master Oscillator	Check 10 MHz output of M.O. board, A6
9. No FM Sig. Gen, CW Sig. Gen OK	VCO on 10 MHz modulator board	Check VCO output at collector of A18Q4
10. No CAL, no Sig. Gen UNLOCKED light on	Master Oscillator board or Crystal Oscillator	Check A6 board for proper outputs
11. FREQUENCY meter pinned in CAL or SIG GEN, Signal Level light on	Second IF and Discriminator	Check 9.9 MHz to board A5 Check A5 board
12. SIGNAL LEVEL light on, no RF in. FREQUENCY METER pinned in MONITOR.	RF Plug-in	Squelch misadjusted
13. UNLOCKED light on but CE-5 appears to work OK	REF. DIVIDER/PHASE DET.	UNLOCKED light control circuits on board A3
14. UNLOCKED light on in some FREQUENCY SELECTOR dial positions	Divide-by-N counter	Check for 100 Hz output from Board A14
15. UNLOCKED light on in all Frequency Selector positions	Frequency Synthesizer loop out of lock	Check outputs of boards A2, A3, A14

SECTION 6

PARTS LISTS AND SCHEMATIC DIAGRAMS

INTRODUCTION

6.01 The following parts lists and schematic diagrams have been arranged in order according to the Circuit Reference Series numbers. Refer to paragraph 4.02. Each schematic diagram and parts list is identified with this number. The circuit boards in the instrument are

etched with the Circuit Board Number. See Cross Reference Table 6-1, below.

6.02 Parts list pages are grouped with the schematic diagrams to which they refer. Component identification drawings showing the location of the individual components on the circuit board are placed on the inner sheet of the schematic diagram to which they apply.

Table 6-1. Printed Circuit Board and Circuit Reference Numbers Cross Reference.

Ckt. Bd. No.	Circuit Title	Ckt. Ref. No.	Assembly No.	Figure No.
	Not Used	A1		
1780-0462	6-10 MHz VCO	A2	7001-0260	6-1
1780-0463	Reference Divider/Phase Detector	A3	7001-0262	6-2
1780-0456	Frequency Error Meter	A4	7001-0204	6-3
1780-0448	Second IF Discriminator	A5	7001-0373	6-4
1780-0061	Master Oscillator/Divider/Filters	A6	7001-0206	6-5
1780-0062	1 kHz-4 kHz Mixer/9.9 MHz Filter	A7	7001-0207	6-6
1780-0065	46.00-50.99 MHz Balanced Mixer	A8	7001-0208	6-7
1780-0066	46.00-50.99 MHz X10 Multiplier	A9	7001-0209	6-8
1780-0067	43 MHz X10 Multiplier	A10	7001-0210	6-9
1780-0078	40 MHz, 43 MHz, and 46 MHz Filter	A11	7001-0211	6-10
1780-0082	Power Supply Regulator	A12	7001-0212	6-11
1780-0084	Power Supply Rectifier	A13	7001-0213	6-12
1780-0089	Divide-by-N	A14	7001-0214	6-13
1780-0450	Switching Logic	A15	7001-0215	6-14
1780-0451	42 MHz Filter, Audio Amplifier, Mixer and IF Switching	A16	7001-0216	6-15
1780-0452	Programmable Phase Lock Loop and Amplifier	A17	7001-0217	6-16
1780-0449	10 MHz Modulator	A18	7001-0374	6-17
1780-0464	RF Mixers and IF Amplifier	A19	7001-0259	6-18
1780-0461	Output Attenuator	A20	7001-0257	6-25
---	20 dB Pad Assembly	-	7040-0016	6-24

6-10 MHz VCO. A2

CKT. REF.	DESCRIPTION	CE STOCK NO.	MFR.	MFR. NO.
A2	6-10 MHz VCO			
	P. C. Board Assembly	7001-0260	Cushman	
	P. C. Board	1780-0462	Cushman	
	CAPACITORS			
C1	Elec, 100 μ F, \pm 10%, 25V	1013-0003	Sprague	30D107G025DD5
C2	Poly, .47 μ F, \pm 10%, 100V	1008-0038	Electrocube	210B1A474K
C3	Met. Mylar, 1 μ F, \pm 10%, 100V	1008-0033	TRW	X663F
C4	Tant, 10 μ F, +50-20%, 35V	1011-0006	ITT	TAG 10/35-20
C5	Poly, .47 μ F, \pm 10%, 100V	1008-0038	Electrocube	210B1A474K
C6	Met. Mylar, 1 μ F, \pm 10%, 100V	1008-0033	TRW	X663F
C7	Tant, 10 μ F, \pm 10%, 20V	1011-0007	Kemet	K10C20K
C8	Elec, 100 μ F, \pm 10%, 25V	1013-0003	Sprague	30D107G025DD5
C9	Cer, .05 μ F, +80-20%, 25V	1005-0014	Erie	5855-505-Y5U0-503 Z
C10	Tant, 10 μ F, \pm 10%, 20V	1011-0007	Kemet	K10C20K
C11	Met. Mylar, 1 μ F, \pm 10%, 100V	1008-0033	TRW	X663F
C12	Elec, 100 μ F, +75-10%, 12V	1013-0011	Sprague	30D107G012CC
C13	Cer, .05 μ F, +80-20%, 25V	1005-0014	Erie	5855-505-Y5U0-503 Z
C14	Cer, .05 μ F, +80-20%, 25V	1005-0014	Erie	5855-505-Y5U0-503 Z
C15	Cer, .05 μ F, +80-20%, 25V	1005-0014	Erie	5855-505-Y5U0-503 Z
C16	Cer, .05 μ F, +80-20%, 25V	1005-0014	Erie	5855-505-Y5U0-503 Z
C17	Mica, 82pF, \pm 5%, 500V	1002-0020	Elmenco	DM15-E-820J
C18	Mica, FSV, \pm 5%, 500V	1002-XXXX	Elmenco	DM15-E-XXXX
C19	Mica, 620pF, \pm 5%, 300V	1002-0038	Elmenco	DM15-F-621J
C20	Cer, .01 μ F, +80-20%, 25V	1005-0013	C-D	CD10ED560J
C21	Mica, 390pF, \pm 5%, 500V	1002-0033	Elmenco	DM15-F-391J
C22	Cer, .05 μ F, +80-20%, 25V	1005-0014	Erie	5855-505-Y5U0-503 Z
C23	Cer, .002 μ F, \pm 20%, 500V	1005-0003	C-D	CD6ED220J
C24	Cer, .05 μ F, +80-20%, 25V	1005-0014	Erie	5855-505-Y5U0-503 Z
C25	Elec, 100 μ F, \pm 10%, 25V	1013-0003	Sprague	30D107G025DD5
C26	Cer, .05 μ F, +80-20%, 25V	1005-0014	Erie	5855-505-Y5U0-503 Z
C27	Cer, .01 μ F, +80-20%, 25V	1005-0013	Erie	5835-512-Y5U-103 Z
C28	Cer, .01 μ F, +80-20%, 25V	1005-0013	Erie	5835-512-Y5U-103 Z
	COILS			
L1	Choke, 1mH, \pm 5%	1585-0020	Delevan	2500-28
L2	Choke, 1mH, \pm 5%	1585-0020	Delevan	2500-28
L3	Choke, 1mH, \pm 5%	1585-0020	Delevan	2500-28
L4	Var, 2.6-4.0 μ H	1596-0113	TRW	51279
L5	Var, 2.0-3.2 μ H	1596-0112	TRW	51278
	DIODES			
CR1	Si, Pin Switching, MPN 3401	1281-0050	Motorola	MPN3401
CR2	Varicap, 250pF, 12V, .4W	1281-0074	Motorola	MV1405
CR3	Si, 75 Piv, 1N3064	1281-0013	Teledyne	1N3064
CR4	Si, 75 Piv, 1N3064	1281-0013	Teledyne	1N3064
	RESISTORS			
R1	Met. Film, 3.4k, \pm 1%, 1/8W	1075-0020	Dale	MFF 1/8 T1
R2	Met. Film, 1.62k, \pm 1%, 1/8W	1075-0104	Dale	MFF 1/8 T1
R3	Met. Film, 3.4k, \pm 1%, 1/8W	1075-0020	Dale	MFF 1/8 T1
R4	Met. Film, 1k, \pm 1%, 1/8W	1075-0037	Dale	MFF 1/8 T1
R5	Met. Film, 10k, \pm 1%, 1/8W	1075-0009	Dale	MFF 1/8 T1

6-10 MHz VCO. A2 (cont)

CKT. REF.	DESCRIPTION	CE STOCK NO.	MFR.	MFR. NO.
R6	Metal Film, 1k, ±1%, 1/8W	1075-0037	Dale	MFF 1/8 T1
R7	Comp, 3k, ±5%, 1/4W	1066-3035	Allen-Bradley	CB3035
R8	Met. Film, 10k, ±1%, 1/8W	1075-0009	Dale	MFF 1/8 T1
R9	Met. Film, 715Ω, ±1%, 1/8W	1075-0085	Dale	MFF 1/8 T1
R10	Met. Film, 715Ω, ±1%, 1/8W	1075-0085	Dale	MFF 1/8 T1
R11	Met. Film 10k, ±1%, 1/8W	1075-0009	Dale	MFF 1/8 T1
R12	Met. Film, 1.62k, ±1%, 1/8W	1075-0104	Dale	MFF 1/8 T1
R13	Met. Film, 1k, ±1%, 1/8W	1075-0037	Dale	MFF 1/8 T1
R14	Comp, 1.3k, ±5%, 1/4W	1066-1325	Allen-Bradley	CB1325
R15	Comp, 10k, ±5%, 1/4W	1066-1035	Allen-Bradley	CB1035
R16	Comp, 2k, ±5%, 1/4W	1066-2025	Allen-Bradley	CB2025
R17	Comp, 10k, ±5%, 1/4W	1066-1035	Allen-Bradley	CB1035
R18	Met. Film, 4.75k, ±1%, 1/8W	1075-0038	Dale	MFF 1/8 T1
R19	Met. Film, 2.21k, ±1%, 1/8W	1075-0010	Dale	MFF 1/8 T1
R20	Comp, 20k, ±5%, 1/4W	1066-2035	Allen-Bradley	CB2035
R21	Comp, 20k, ±5%, 1/4W	1066-2035	Allen-Bradley	CB2035
R22	Met. Film, 1.5k, ±1%, 1/8W	1075-0039	Dale	MFF 1/8 T1
R23	Met. Film, 26.1Ω, ±1%, 1/10W	1074-1011	Dale	LMF 1/10 T1
R24	Met. Film, 1k, ±1%, 1/8W	1075-0037	Dale	MFF 1/8 T1
R25	Met. Film, 2.21k, ±1%, 1/8W	1075-0010	Dale	MFF 1/8 T1
R26	Comp, 2.7k, ±5%, 1/4W	1066-2725	Allen-Bradley	CB2725
R27	Comp, 51Ω, ±5%, 1/4W	1066-5105	Allen-Bradley	CB5105
R28	Comp, 1k, ±5%, 1/4W	1066-1025	Allen-Bradley	CB1025
R29	Met. Film, 2k, ±1%, 1/8W	1075-0103	Dale	MFF 1/8 T1
R30	Met. Film, 2.74k, ±1%, 1/8W	1075-0071	Dale	MFF 1/8 T1
R31	Comp, 100Ω, ±5%, 1/4W	1066-1015	Allen-Bradley	CB1015
R32	Comp, 1k, ±5%, 1/4W	1066-1025	Allen-Bradley	CB1025
TRANSISTORS				
Q1	Si, NPN, 2N5962	1272-0059	Fairchild	2N5962
Q2	Si, NPN, 2N3565	1272-0017	Fairchild	2N3565
Q3	Si, NPN, 2N3565	1272-0017	Fairchild	2N3565
Q4	Si, NPN, 2N3565	1272-0017	Fairchild	2N3565
Q5	Si, NPN, 2N3565	1272-0017	Fairchild	2N3565
Q6	Si, NPN, 2N3565	1272-0017	Fairchild	2N3565
Q7	Si, PNP, 2N3638	1272-0015	Fairchild	2N3638
Q8	Si, NPN, 2N5179	1272-0060	Motorola	2N5179
Q9	Si, NPN, 2N3565	1272-0017	Fairchild	2N3565
Q10	Si, NPN, 2N3565	1272-0017	Fairchild	2N3565
Q11	Si, NPN, 2N3565	1272-0017	Fairchild	2N3565

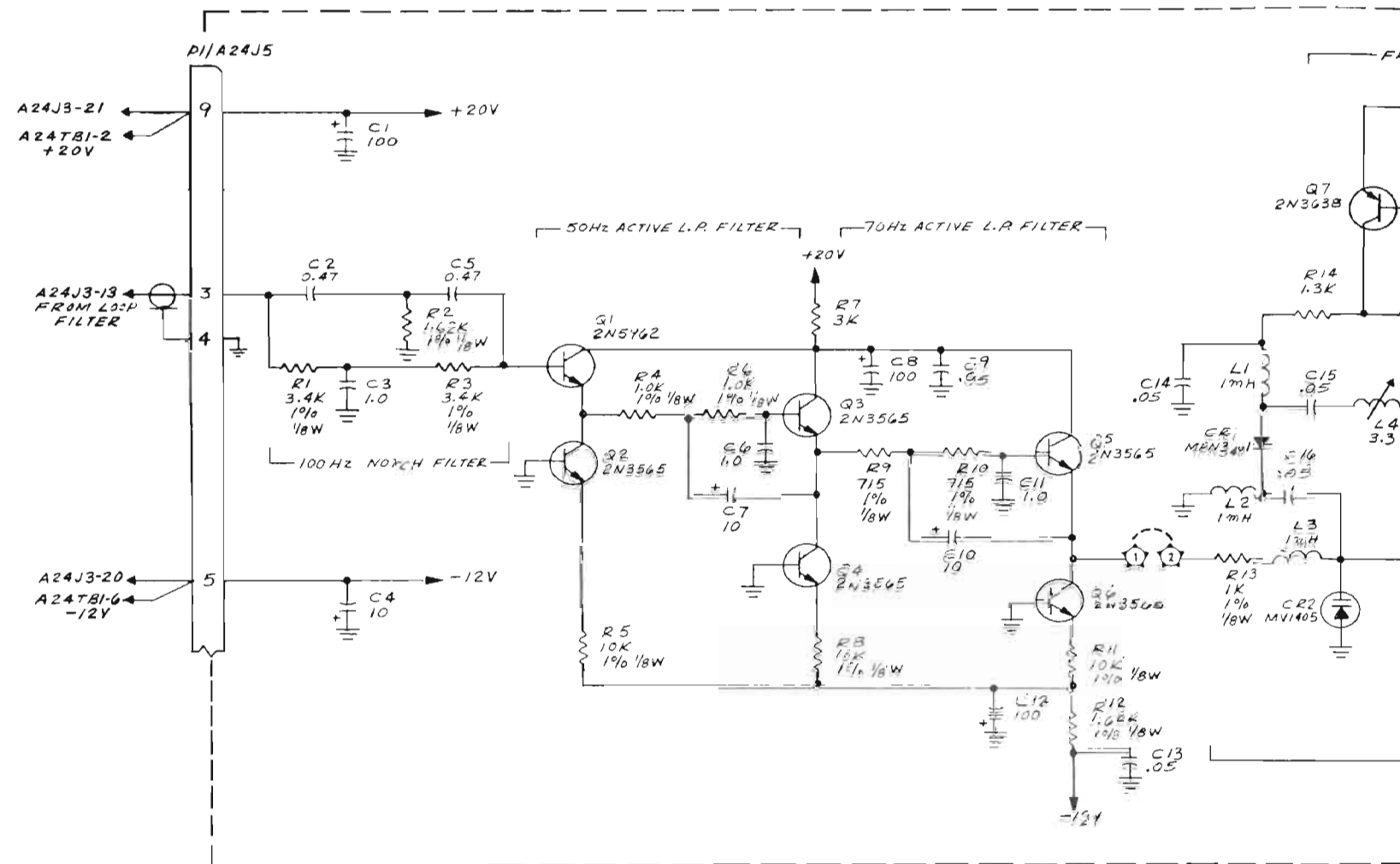
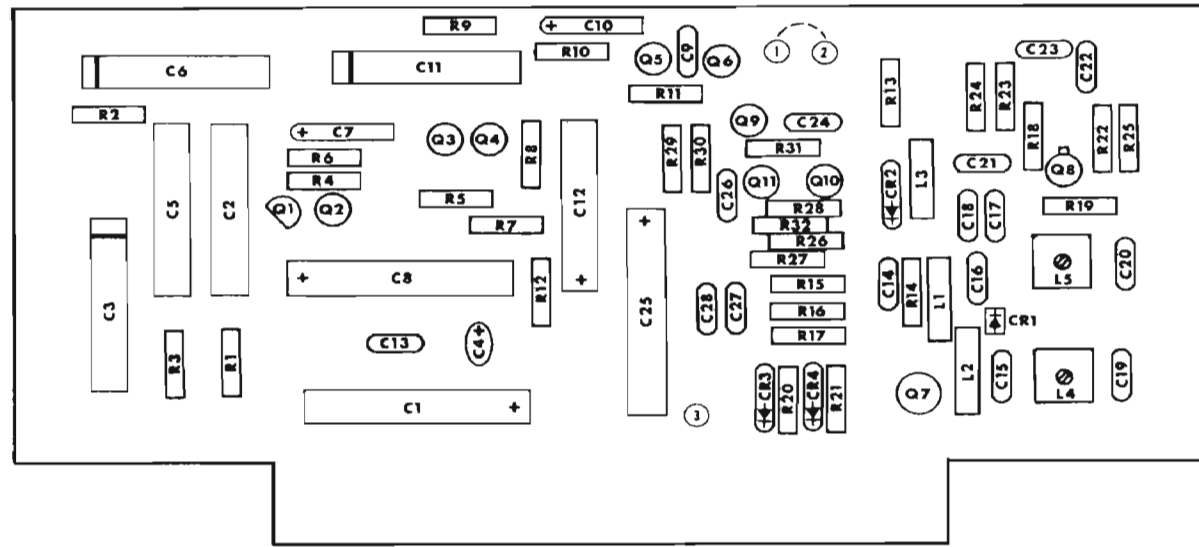

NOTE:
 1. RESISTORS - 1/4W, 5% VALUES IN OHMS UNLESS OTHERWISE NOTED.
 2. CAPACITORS - VALUES IN μ F UNLESS OTHERWISE NOTED.
 3. INDUCTORS - VALUES IN μ H UNLESS OTHERWISE NOTED.
 4. *FACTORY SELECT. TYPICAL VALUE SHOWN.
 5. ALL VOLTAGES ARE DC UNLESS OTHERWISE NOTED.

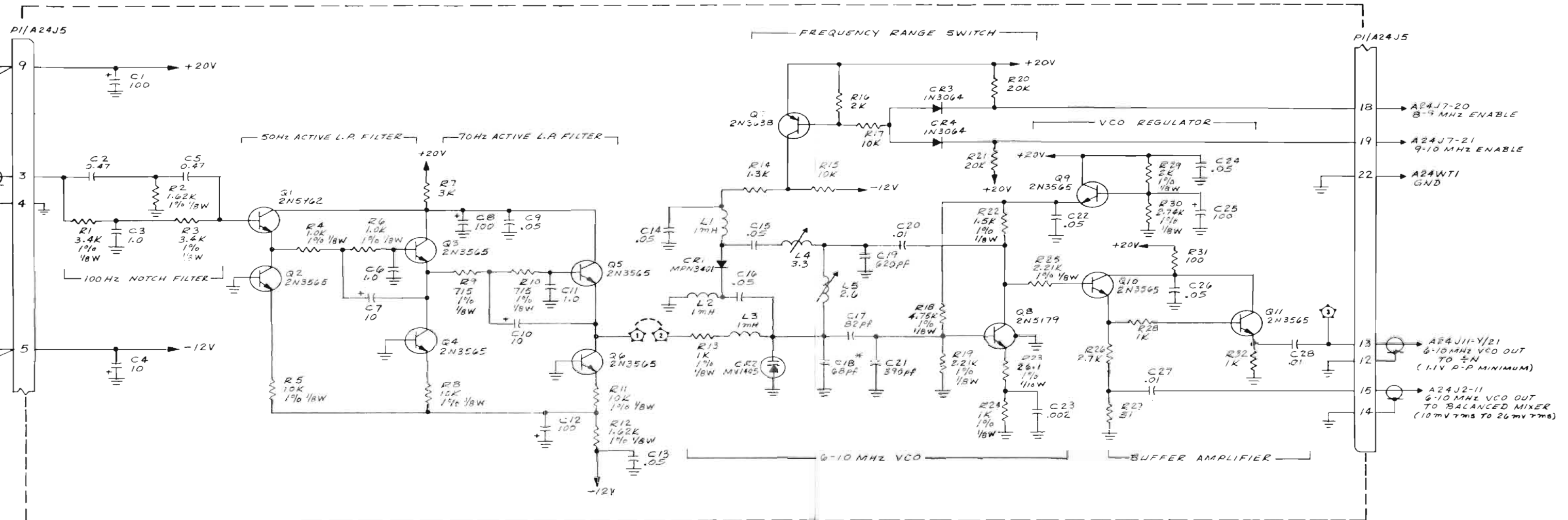

NOTE:
 1. RESISTORS - 1/4W, 5% VALUES IN OHMS UNLESS OTHERWISE NOTED.
 2. CAPACITORS - VALUES IN μ F UNLESS OTHERWISE NOTED.
 3. INDUCTORS - VALUES IN μ H UNLESS OTHERWISE NOTED.
 4. *FACTORY SELECT- TYPICAL VALUE SHOWN.
 5. ALL VOLTAGES ARE DC UNLESS OTHERWISE NOTED.

Figure 6-1. 6-10 MHz VCO. A2
 6-5/6-6

REFERENCE DIVIDER/PHASE DETECTOR A3

CKT. REF.	DESCRIPTION	CE STOCK NO.	MFR.	MFR. NO.
A3	Ref. Divider/Phase Detector P.C. Board Assembly	7001-0262	Cushman	
	P.C. Board	1780-0463	Cushman	
	CAPACITORS			
C1	Cer, .05 μ F, +80-20%, 25V	1005-0014	Erie	5855-505-Y5U0-503Z
C2	Elec, 100 μ F, +75-10%, 12V	1013-0011	Sprague	30D107G012CC5
C3	Cer, .05 μ F, +80-20%, 25V	1005-0014	Erie	5855-505-Y5U0-503Z
C4	Cer, .05 μ F, +80-20%, 25V	1005-0014	Erie	5855-505-Y5U0-503Z
C5	Cer, .05 μ F, +80-20%, 25V	1005-0014	Erie	5855-505-Y5U0-503Z
C6	Cer, .05 μ F, +80-20%, 25V	1005-0014	Erie	5855-505-Y5U0-503Z
C7	Cer, .05 μ F, +80-20%, 25V	1005-0014	Erie	5855-505-Y5U0-503Z
C8	Cer, .05 μ F, +80-20%, 25V	1005-0014	Erie	5855-505-Y5U0-503Z
C9	Cer, .05 μ F, +80-20%, 25V	1005-0014	Erie	5855-505-Y5U0-503Z
C10	Cer, .05 μ F, +80-20%, 25V	1005-0014	Erie	5855-505-Y5U0-503Z
C11	Poly, .22 μ F, \pm 10%, 100V	1008-0091	Electrocube	232A1B224K
C12	Cer, .05 μ F, +80-20%, 25V	1005-0014	Erie	5855-505-Y5U0-503Z
C13	Met. Mylar, 1 μ F, \pm 10%, 100V	1008-0033	TRW	X663F
C14	Cer, .05 μ F, +80-20%, 25V	1005-0014	Erie	5855-505-Y5U0-503Z
C15	Mica, 100pF, \pm 5%, 500V	1002-0011	Elmenco	DM15-F-101J
C16	Cer, .05 μ F, +80-20%, 25V	1005-0014	Erie	5855-505-Y5U0-503Z
C17	Tant, 10 μ F, +50-20%, 35V	1011-0006	ITT	TAG10/35-20
C18	Poly, .1 μ F, \pm 10%, 100V	1008-0031	Sprague	225P10491
C19	Poly, .1 μ F, \pm 10%, 100V	1008-0031	Sprague	225P10491
C20	Cer, .01 μ F, +80-20%, 25V	1005-0013	Erie	5835-512-Y5U-103Z
C21	Tant, 10 μ F, \pm 10%, 20V	1011-0007	Kemet	K10C20K
	DIODES			
CR1	Si, 75 PIV, 1N3064	1281-0013	Teledyne	1N3064
CR2	Si, 75 PIV, 1N3064	1281-0013	Teledyne	1N3064
CR3	Si, 75 PIV, 1N3064	1281-0013	Teledyne	1N3064
CR4	Si, 75 PIV, 1N3064	1281-0013	Teledyne	1N3064
CR5	Si, 75 PIV, 1N3064	1281-0013	Teledyne	1N3064
	INTEGRATED CIRCUITS			
IC1	Decade Counter SN7490N	2025-0002	T.I.	SN7490N
IC2	Quad 2-Input Pos-NAND	2025-0003	T.I.	SN7400N
IC3	Decade Counter SN7490N	2025-0002	T.I.	SN7490N
IC4	Decade Counter SN7490N	2025-0002	T.I.	SN7490N
IC5	Decade Counter SN7490N	2025-0002	T.I.	SN7490N
IC6	Quad 2-Input Pos-NAND	2025-0003	T.I.	SN7400N
IC7	Phase-Frequency Detector	2025-0066	Motorola	MC4044P
IC8	Op Amp, LM308H	2025-0057	National	LM308H
IC9	Quad 2-Input Pos-NAND	2025-0003	T.I.	SN7400N
IC10	Quad 2-Input Pos-NAND	2025-0003	T.I.	SN7400N
IC11	Op Amp, SN72741P	2025-0067	T.I.	SN72741P
	RESISTORS			
R1	Comp, 3.3k, \pm 5%, 1/4W	1066-3325	Allen-Bradley	CB3325
R2	Comp, 510 Ω , \pm 5%, 1/4W	1066-5115	Allen-Bradley	CB5115
R3	Comp, 510 Ω , \pm 5%, 1/4W	1066-5115	Allen-Bradley	CB5115
R4	Comp, 1.5k, \pm 5%, 1/4W	1066-1525	Allen-Bradley	CB1525
R5	Comp, 1.2k, \pm 5%, 1/4W	1066-1225	Allen-Bradley	CB1225

REFERENCE DIVIDER/PHASE DETECTOR A3 (cont)

CKT. REF.	DESCRIPTION	CE STOCK NO.	MFR.	MFR. NO.
R6	Met. Film, 6.81k, $\pm 1\%$, 1/8W	1075-0140	Dale	MFF 1/8 T1
R7	Met. Film, 6.81k, $\pm 1\%$, 1/8W	1075-0140	Dale	MFF 1/8 T1
R8	Met. Film, 130k, $\pm 1\%$, 1/8W	1075-0114	Dale	MFF 1/8 T1
R9	Met. Film, 1k, $\pm 1\%$, 1/8W	1075-0037	Dale	MFF 1/8 T1
R10	Comp, FSV, $\pm 5\%$, 1/4W	1066-XXXX	Allen-Bradley	CBXXXX
R11	Comp, FSV, $\pm 5\%$, 1/4W	1066-XXXX	Allen-Bradley	CBXXXX
R12	Comp, FSV, $\pm 5\%$, 1/4W	1066-XXXX	Allen-Bradley	CBXXXX
R13	Comp, FSV, $\pm 5\%$, 1/4W	1066-XXXX	Allen-Bradley	CBXXXX
R14	Comp, FSV, $\pm 5\%$, 1/4W	1066-XXXX	Allen-Bradley	CBXXXX
R15	Met. Film, 79.3k, $\pm 1\%$, 1/8W	1075-0074	Dale	MFF 1/8 T1
R16	Comp, 3k, $\pm 5\%$, 1/4W	1066-3025	Allen-Bradley	CB3025
R17	Met. Film, 18.2k, $\pm 1\%$, 1/8W	1075-0075	Dale	MFF 1/8 T1
R18	Met. Film, 1.62k, $\pm 1\%$, 1/8W	1075-0070	Dale	MFF 1/8 T1
R19	Comp, 4.7k, $\pm 5\%$, 1/4W	1066-4725	Allen-Bradley	CB4725
R20	Comp, 3k, $\pm 5\%$, 1/4W	1066-3025	Allen-Bradley	CB3025
R21	Comp, 330k, $\pm 5\%$, 1/4W	1066-3345	Allen-Bradley	CB3345
R22	Comp, 1k, $\pm 5\%$, 1/4W	1066-1025	Allen-Bradley	CB1025
R23	Comp, 100k, $\pm 5\%$, 1/4W	1066-1045	Allen-Bradley	CB1045
R24	Comp, 3k, $\pm 5\%$, 1/4W	1066-3025	Allen-Bradley	CB3025
R25	Comp, 1k, $\pm 5\%$, 1/4W	1066-1025	Allen-Bradley	CB1025
R26	Comp, 680 Ω , $\pm 5\%$, 1/4W	1066-6815	Allen-Bradley	CB6815
R27	Comp, 680 Ω , $\pm 5\%$, 1/4W	1066-6815	Allen-Bradley	CB6815
R28	Comp, 470 Ω , $\pm 5\%$, 1/4W	1066-4715	Allen-Bradley	CB4715
R29	Comp, 100 Ω , $\pm 5\%$, 1/2W	1067-1015	Allen-Bradley	CB1015
TRANSISTORS				
Q1	Si, NPN, 2N4275	1272-0016	Fairchild	2N4275
Q2	Si, PNP, 2N4249	1272-0024	Fairchild	2N4249
Q3	Si, PNP, 2N4249	1272-0024	Fairchild	2N4249
Q4	Si, NPN, 2N3563	1272-0022	Fairchild	2N3563
Q5	Si, NPN, 2N4275	1272-0016	Fairchild	2N4275

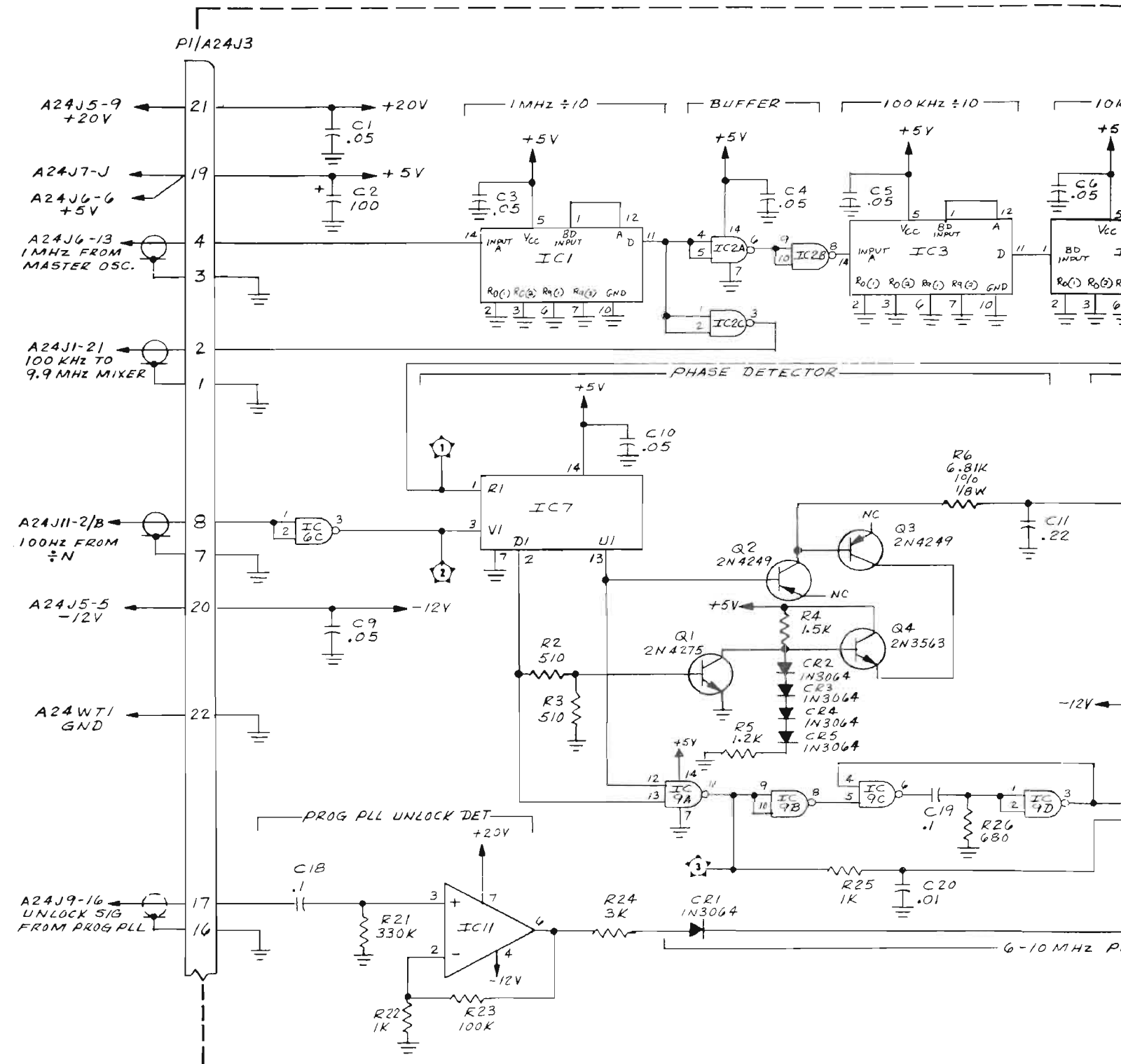
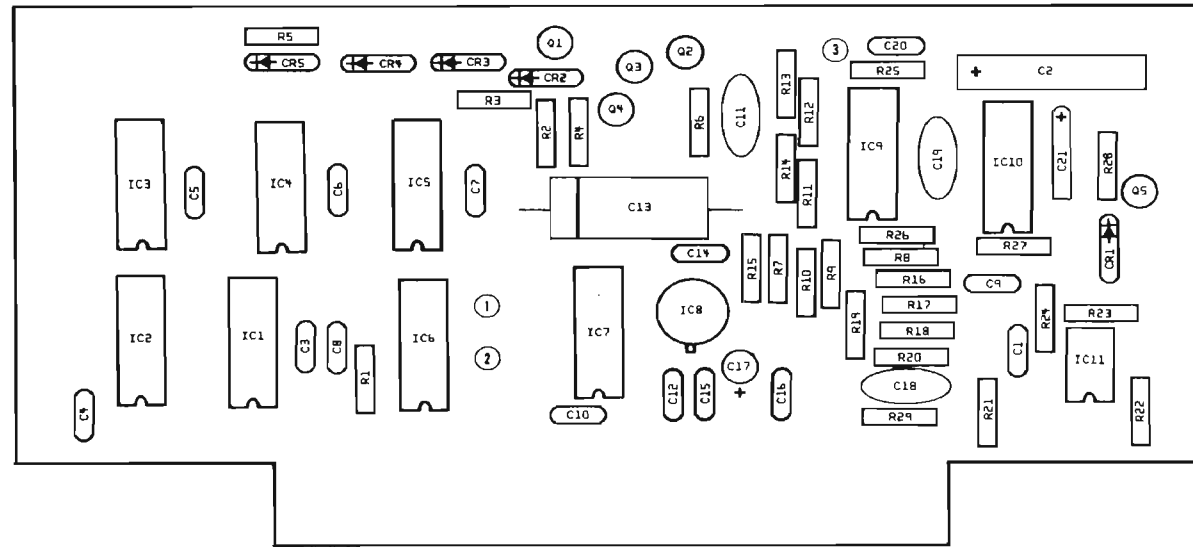

NOTE:
 1. RESISTORS - 1/4W, 5% VALUES IN OHMS UNLESS OTHERWISE NOTED.
 2. CAPACITORS - VALUES IN μ F UNLESS OTHERWISE NOTED.
 3. INDUCTORS - VALUES IN μ H UNLESS OTHERWISE NOTED.
 4. *FACTORY SELECT. TYPICAL VALUE SHOWN.
 5. ALL VOLTAGES ARE DC UNLESS OTHERWISE NOTED.

IC NO	TYPE
1, 3, 4, 5	SN7490N
2, 6, 9, 10	SN7400N
7	MC4044P
8	LM308H
11	SN7274IN

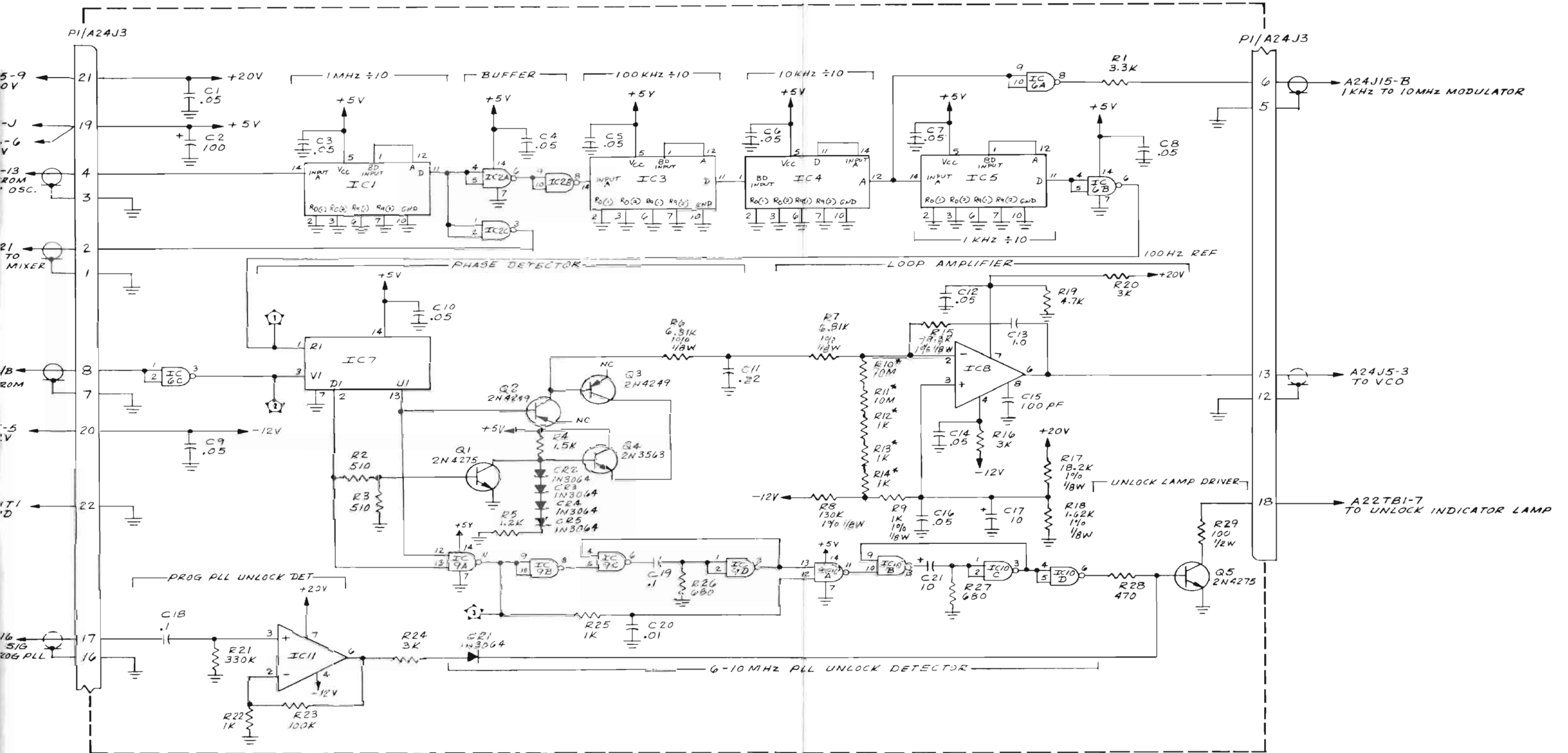

NOTE:
 1. RESISTORS - 1/4W, 5% VALUES IN OHMS UNLESS OTHERWISE NOTED.
 2. CAPACITORS - VALUES IN μ F UNLESS OTHERWISE NOTED.
 3. INDUCTORS - VALUES IN μ H UNLESS OTHERWISE NOTED.
 4. *FACTORY SELECT. TYPICAL VALUE SHOWN.
 5. ALL VOLTAGES ARE DC UNLESS OTHERWISE NOTED.

IC NO	TYPE
1,3,4,5	SN7490N
2,6,9,12	SN7400N
7	MC4044P
8	LM308H
11	SN7274IN

Figure 6-2. Reference Divider/Phase Detector. A3
 6-9/6-10

FREQUENCY ERROR METER. A4

CKT. REF.	DESCRIPTION	CE STOCK NO.	MFR.	MFR. NO.
A4	Frequency Error Meter Board Assy	7001-0204	Cushman	
	Printed Circuit Board	1780-0456	Cushman	
	DIODES			
CR1	Si, 1N816	1281-0009	Transitron	1N816
CR2	Si, 1N816	1281-0009	Transitron	1N816
CR3	Si, 1N3064	1281-0013	Teledyne	1N3064
	RELAYS			
K1	12V DC, DPDT	1313-0002	Parelco	R102E-Z2-V185
	RESISTORS			
R1	Comp, 27k Ω , $\pm 5\%$, 1/4W	1066-2735	Allen-Bradley	CB2735
R2	Comp, 6.8k Ω , $\pm 5\%$, 1/4W	1066-6825	Allen-Bradley	CB6825
R3	Comp, 33 Ω , $\pm 5\%$, 1/4W	1066-3305	Allen-Bradley	CB3305
R4	Pot, 10k Ω , $\pm 10\%$, 3/4W	1215-0014	Helitrim	89WR
R5	Pot, 5k Ω , $\pm 10\%$, 3/4W	1215-0012	Helitrim	89WR
R6	Pot, 1k Ω , $\pm 10\%$, 3/4W	1215-0013	Helitrim	89WR
R7	Comp, 4.7k Ω , $\pm 5\%$, 1/4W	1066-4725	Allen-Bradley	CB4725

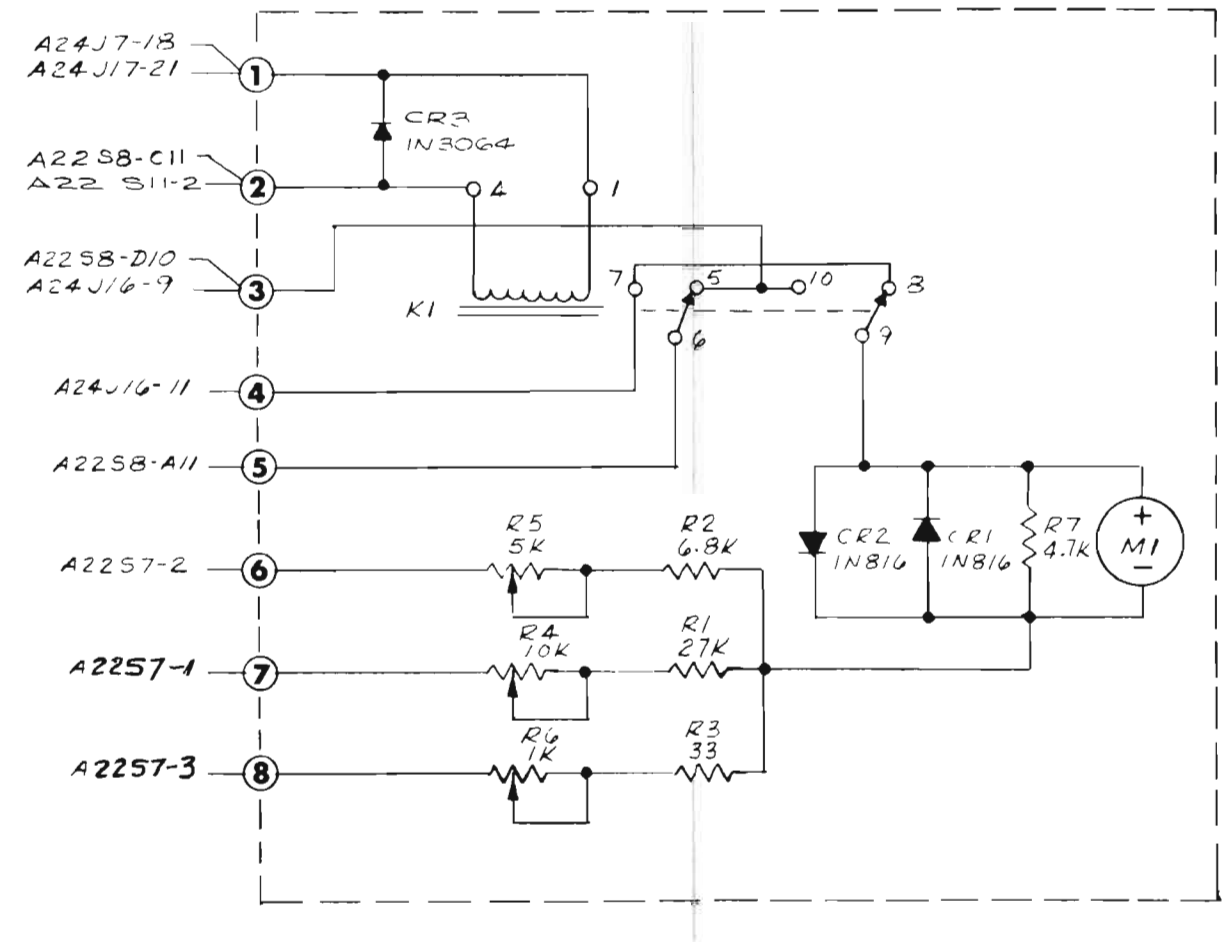
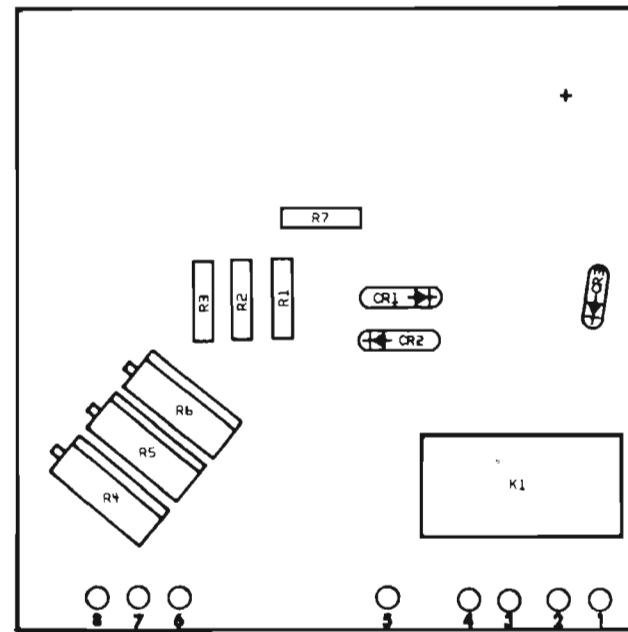

- NOTE:
1. RESISTORS - 1/4W, 5% VALUES IN OHMS UNLESS OTHERWISE NOTED.
 2. CAPACITORS - VALUES IN μ F UNLESS OTHERWISE NOTED.
 3. INDUCTORS - VALUES IN μ H UNLESS OTHERWISE NOTED.
 4. *FACTORY SELECT. TYPICAL VALUE SHOWN.
 5. ALL VOLTAGES ARE DC UNLESS OTHERWISE NOTED.

Figure 6-3. Frequency Error Meter. A4

SECOND IF/DISCRIMINATOR, A5

CKT. REF.	DESCRIPTION	CE STOCK NO.	MFR.	MFR. NO.
A5	Second IF and Discriminator Board Assy	7001-0373	Cushman	
	Printed Circuit Board	1780-0448	Cushman	
CAPACITORS				
C1	Cer, .01 μ F, +80% -20%, 25V	1005-0013	Erie	5835/512/Y5U/103Z
C2	Cer, .01 μ F, +80% -20%, 25V	1005-0013	Erie	5835/512/Y5U/103Z
C3	Cer, .01 μ F, +80% -20%, 25V	1005-0013	Erie	5835/512/Y5U/103Z
C4	Elect, 100 μ F, +75% -10%, 12V	1013-0011	Sprague	30D107G012CC5
C5	Elect, 15 μ F, \pm 10%, 25V	1013-0005	Sprague	30D156G025BB5
C6	Cer, .01 μ F, +80% -20%, 25V	1005-0013	Erie	5835/512/Y5U/103Z
C7	Cer, .01 μ F, +80% -20%, 25V	1005-0013	Erie	5835/512/Y5U/103Z
C8	Cer, .05 μ F, +80% -20%, 25V	1005-0014	Erie	5835/505/Y5U0/503Z
C9	Elect, 15 μ F, +75%, -10%, 12V	1013-0015	Sprague	30D156G012BA5
C10	Cer, 2.2pF, \pm .25pF, 500V	1005-0017	Erie	301-000-C0J0-229C
C11	Mica, 430pF, \pm 5%, 500V	1002-0034	Elmenco	DM15-F-431J
C12	Mica, 430pF, \pm 5%, 500V	1002-0034	Elmenco	DM15-F-431J
C13	Cer, 3.3pF, \pm .25pF, 500V	1005-0011	Erie	301-000-C0J0-339C
C14	Cer, .05 μ F, +80% -20%, 25V	1005-0014	Erie	5835/505/Y5U0/503Z
C15	Cer, .05 μ F, +80% -20%, 25V	1005-0014	Erie	5835/505/Y5U0/503Z
C16	Cer, .01 μ F, +80% -20%, 25V	1005-0013	Erie	5835/512/Y5U/103Z
C17	Mica, 470pF, \pm 5%, 500V	1002-0035	Elmenco	DM15-F-471J
C18	Cer, .05 μ F, +80% -20%, 25V	1005-0014	Erie	5835/505/Y5U0/503Z
C19	Mica, 470pF, \pm 5%, 500V	1002-0035	Elmenco	DM15-F-471J
C20	Not Used			
C21	Cer, .05 μ F, +80% -20%, 25V	1005-0014	Erie	5835/505/Y5U0/503Z
C22	Elect, 470 μ F or 500 μ F, 25V	1014-0020	Illinois Cap.	25T470
C23	Mica, 100pF, \pm 5%, 500V	1002-0011	Elmenco	DM15-F-101J
C24	Mica, 470pF, \pm 5%, 500V	1002-0035	Elmenco	DM15-F-471J
C25	Poly, .027 μ F, \pm 10%, 100V	1008-0032	Sprague	225P27391
C26	Poly, .027 μ F, \pm 10%, 100V	1008-0032	Sprague	225P27391
C27	Mica, 2000pF, \pm 5%, 500V	1002-0077	Elmenco	DM19-E-202J
C28	Poly, .027 μ F, \pm 10%, 100V	1008-0032	Sprague	225P27391
C29	Poly, .027 μ F, \pm 10%, 100V	1008-0032	Sprague	225P27391
C30	Mica, 470pF, \pm 1%, 500V	1002-0044	Elmenco	DM15-F-471F
C31	Cer, .05 μ F, +80% -20%, 25V	1005-0014	Erie	5835/505/Y5U0/503Z
C32	Elect, 15 μ F, \pm 10%, 25V	1013-0005	Sprague	30D156G025BB5
C33	Cer, .01 μ F, +80% -20%, 25V	1005-0013	Erie	5835/512/Y5U/103Z
C34	Cer, .01 μ F, +80% -20%, 25V	1005-0013	Erie	5835/512/Y5U/103Z
C35	Cer, .05 μ F, +80% -20%, 25V	1005-0014	Erie	5835/505/Y5U0/503Z
COILS				
L1	RF Choke, 470 μ H, \pm 5%	1585-0019	Delevan	2500-12
L2	RF Choke, 470 μ H, \pm 5%	1585-0019	Delevan	2500-12
L3	Var. Inductor, 8 turns, 16 MHz	1596-0011	TRW	21024
L4	Var. Inductor, 8 turns, 16 MHz	1596-0011	TRW	21024
L5	RF Choke, 82 μ H, \pm 5%	1585-0032	Delevan	1537-72
L6	RF Choke, 82 μ H, \pm 5%	1585-0032	Delevan	1537-72
L7	RF Choke, 2.2mH, \pm 5%	1585-0030	Delevan	2500-44
L8	RF Choke, 4.7mH, \pm 5%	1585-0006	Delevan	2500-60
L9	RF Choke, 4.7mH, \pm 5%	1585-0006	Delevan	2500-60
L10	RF Choke, 2.2mH, \pm 5%	1585-0030	Delevan	2500-44
L11	RF Choke, 22mH, \pm 15%	1585-0029	Delevan	2534-56
L12	RF Choke, 22mH, \pm 15%	1585-0029	Delevan	2534-56

SECOND IF/DISCRIMINATOR (cont). A5

CKT. REF.	DESCRIPTION	CE STOCK NO.	MFR.	MFR. NO.
DIODES				
CR1	Ge, G633	1282-0005	ITT	G633
CR2	Ge, G633	1282-0005	ITT	G633
CR3	Ge, G633	1282-0005	ITT	G633
CR4	Si, 1N3064	1281-0013	Teledyne	1N3064
CR5	Si, 1N3064	1281-0013	Teledyne	1N3064
CR6	Si, 1N3064	1281-0013	Teledyne	1N3064
CR7	Si, 1N3064	1281-0013	Teledyne	1N3064
CR8	Ge, G633	1282-0005	ITT	G633
CR9	Si, 1N3064	1281-0013	Teledyne	1N3064
CR10	Si, 1N3064	1281-0013	Teledyne	1N3064
INTEGRATED CIRCUITS				
IC1	RF Ampl, CA3028A	2025-0012	RCA	CA3028A
IC2	RF Ampl, CA3028A	2025-0012	RCA	CA3028A
RESISTORS				
R1	Comp, 3.9k Ω , $\pm 5\%$, 1/4W	1066-3925	Allen-Bradley	CB3925
R2	Comp, 3.9k Ω , $\pm 5\%$, 1/4W	1066-3925	Allen-Bradley	CB3925
R3	Comp, 3.3k Ω , $\pm 5\%$, 1/4W	1066-3325	Allen-Bradley	CB3325
R4	Comp, 1.2k Ω , $\pm 5\%$, 1/4W	1066-1225	Allen-Bradley	CB1225
R5	Comp, 2.2k Ω , $\pm 5\%$, 1/4W	1066-2225	Allen-Bradley	CB2225
R6	Comp, 51 Ω , $\pm 5\%$, 1/4W	1066-5105	Allen-Bradley	CB5105
R7	Comp, 220 Ω , $\pm 5\%$, 1/4W	1066-2215	Allen-Bradley	CB2215
R8	Comp, 1k Ω , $\pm 5\%$, 1/4W	1066-1025	Allen-Bradley	CB1025
R9	Comp, 3.9k Ω , $\pm 5\%$, 1/4W	1066-3925	Allen-Bradley	CB3925
R10	Comp, 1k Ω , $\pm 5\%$, 1/4W	1066-1025	Allen-Bradley	CB1025
R11	Comp, 4.7k Ω , $\pm 5\%$, 1/4W	1066-4725	Allen-Bradley	CB4725
R12	Comp, 2.2k Ω , $\pm 5\%$, 1/4W	1066-2225	Allen-Bradley	CB2225
R13	Comp, 22 Ω , $\pm 5\%$, 1/4W	1066-2205	Allen-Bradley	CB2205
R14	Comp, 3.9k Ω , $\pm 5\%$, 1/4W	1066-3925	Allen-Bradley	CB3925
R15	Comp, 1.5k Ω , $\pm 5\%$, 1/4W	1066-1525	Allen-Bradley	CB1525
R16	Comp, 1k Ω , $\pm 5\%$, 1/4W	1066-1025	Allen-Bradley	CB1025
R17	Comp, 1.2k Ω , $\pm 5\%$, 1/4W	1066-1225	Allen-Bradley	CB1225
R18	Comp, 2.2k Ω , $\pm 5\%$, 1/4W	1066-2225	Allen-Bradley	CB2225
R19	Comp, 2.2k Ω , $\pm 5\%$, 1/4W	1066-2225	Allen-Bradley	CB2225
R20	Comp, 2.2k Ω , $\pm 5\%$, 1/4W	1066-2225	Allen-Bradley	CB2225
R21	Comp, 820 Ω , $\pm 5\%$, 1/2W	1067-8215	Allen-Bradley	EB8215
R22	Comp, 12k Ω , $\pm 5\%$, 1/4W	1066-1235	Allen-Bradley	CB1235
R23	Comp, 3.3k Ω , $\pm 5\%$, 1/4W	1066-3325	Allen-Bradley	CB3325
R24	Comp, 3.3k Ω , $\pm 5\%$, 1/4W	1066-3325	Allen-Bradley	CB3325
R25	Comp, 22 Ω , $\pm 5\%$, 1/4W	1066-2205	Allen-Bradley	CB2205
R26	Comp, 2.2k Ω , $\pm 5\%$, 1/4W	1066-2225	Allen-Bradley	CB2225
R27	Comp, 560 Ω , $\pm 5\%$, 1/4W	1066-5615	Allen-Bradley	CB5615
R28	Comp, 15 Ω , $\pm 5\%$, 1/4W	1066-1505	Allen-Bradley	CB1505
R29	Comp, 2.2k Ω , $\pm 5\%$, 1/4W	1066-2225	Allen-Bradley	CB2225
R30	M Film, 3.24k Ω , $\pm 1\%$, 1/8W	1075-0092	Dale	MFF1/8T1
R31	M Film, 10k Ω , $\pm 1\%$, 1/8W	1075-0009	Dale	MFF1/8T1
R32	Comp, 3.3k Ω , $\pm 5\%$, 1/4W	1066-3325	Allen-Bradley	CB3325
R33	M Film, 332 Ω , $\pm 1\%$, 1/8W	1075-0024	Dale	MFF1/8T1
R34	M Film, 2.21k Ω , $\pm 1\%$, 1/8W	1075-0010	Dale	MFF1/8T1
R35	Comp, 10k Ω , $\pm 5\%$, 1/4W	1066-1035	Allen-Bradley	CB1035
R36	Comp, 12k Ω , $\pm 5\%$, 1/4W	1066-1235	Allen-Bradley	CB1235
R37	Not Used			
R38	M Film, 1k Ω , $\pm 1\%$, 1/2W	1076-0007	Dale	MFF1/2T1
R39	M Film, 357 Ω , $\pm 1\%$, 1/2W	1076-0012	Dale	MFF1/2T1
R40	Comp, 1k Ω , $\pm 5\%$, 1/4W	1066-1025	Allen-Bradley	CB1025

SECOND IF/DISCRIMINATOR (cont). A5

CKT. REF.	DESCRIPTION	CE STOCK NO.	MFR.	MFR. NO.
R41	Comp, 470 Ω , $\pm 5\%$, 1/4W	1066-4715	Allen-Bradley	CB4715
R42	M Film, 475 Ω , $\pm 1\%$, 1/8W	1075-0023	Dale	MFF 1/8 T1
R43	M Film, 14.7k Ω , $\pm 1\%$, 1/4W	1077-0002	Dale	MFF 1/4 T1
R44	Comp, 4.7k Ω , $\pm 5\%$, 1/4W	1066-4725	Allen-Bradley	CB4725
R45	Comp, 33k Ω , $\pm 5\%$, 1/4W	1066-3335	Allen-Bradley	CB3335
R46	M Film, 1k Ω , $\pm 1\%$, 1/2W	1076-0007	Dale	MFF 1/2 T1
R47	M Film, 274 Ω , $\pm 1\%$, 1/2W	1076-0013	Dale	MFF 1/2 T1
R48	Comp, 1.2k Ω , $\pm 5\%$, 1/2W	1067-1225	Allen-Bradley	EB1225
R49	Pot, 200 Ω , $\pm 10\%$, 1/4W	1200-0016	Allen-Bradley	F FR201U
TRANSISTORS				
Q1	Si, PNP, TIS 37	1271-0003	T. I.	TIS 37
Q2	Si, NPN, 2N3565	1272-0017	Fairchild	2N3565
Q3	Si, NPN, 2N3565	1272-0017	Fairchild	2N3565
Q4	Si, NPN, 2N3567	1272-0014	Fairchild	2N3567
Q5	Si, NPN, 2N3565	1272-0017	Fairchild	2N3565
Q6	Si, NPN, 2N4275	1272-0016	Fairchild	2N4275
Q7	Si, NPN, 2N3565	1272-0017	Fairchild	2N3565
Q8	Si, NPN, 2N4275	1272-0016	Fairchild	2N4275
Q9	Si, NPN, 2N3565	1272-0017	Fairchild	2N3565
Q10	Si, NPN, 2N4275	1272-0016	Fairchild	2N4275

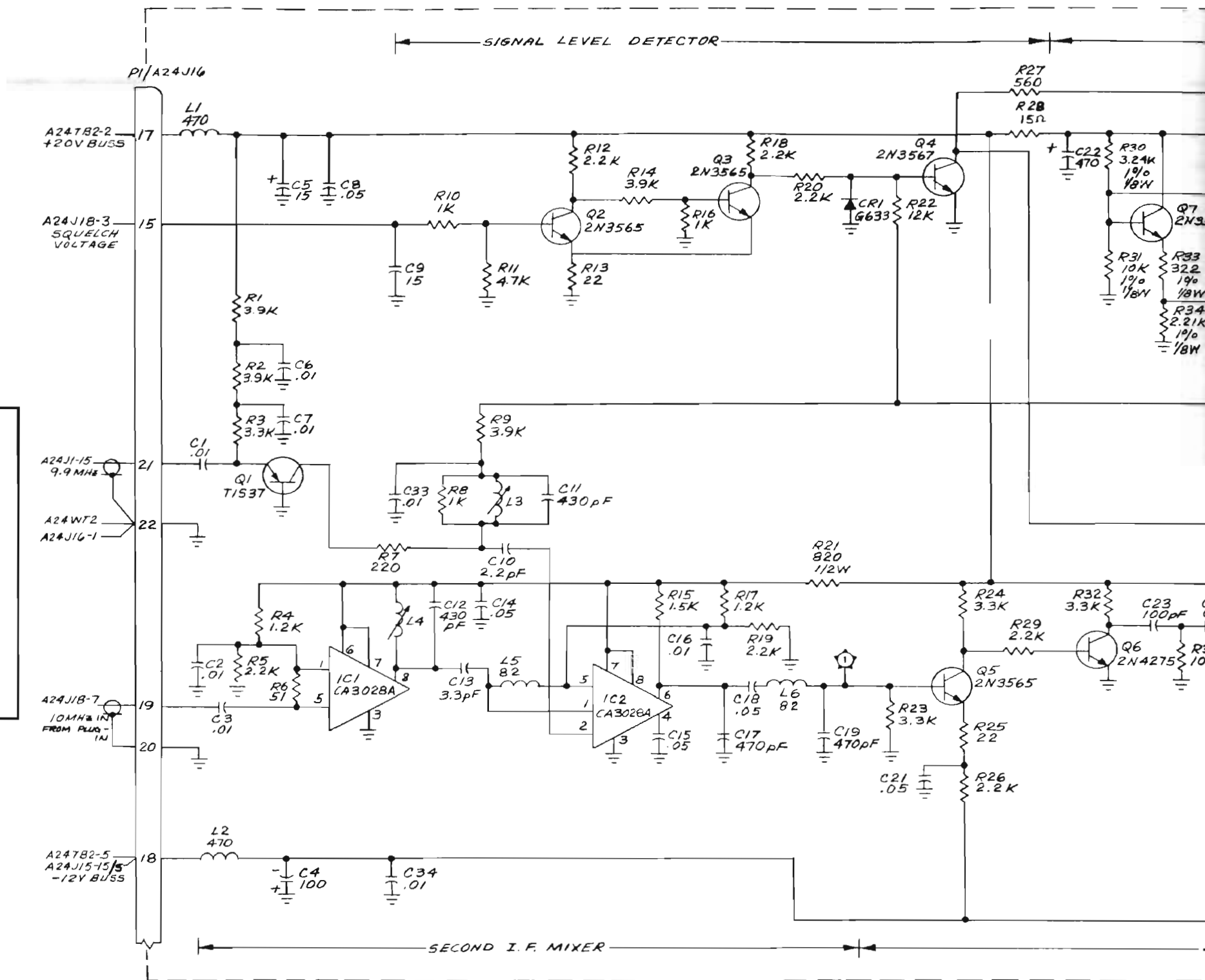
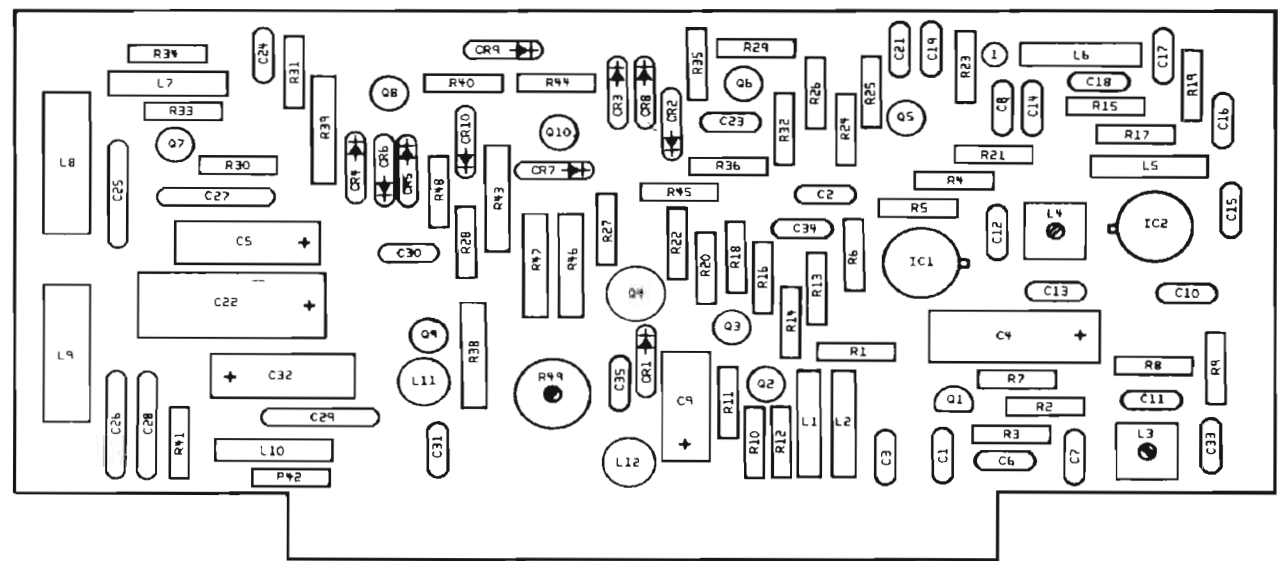

NOTE:

1. RESISTORS - 1/4W, 5% VALUES IN OHMS UNLESS OTHERWISE NOTED.
2. CAPACITORS - VALUES IN μ F UNLESS OTHERWISE NOTED.
3. INDUCTORS - VALUES IN μ H UNLESS OTHERWISE NOTED.
4. *FACTORY SELECT. TYPICAL VALUE SHOWN.
5. ALL VOLTAGES ARE DC UNLESS OTHERWISE NOTED.

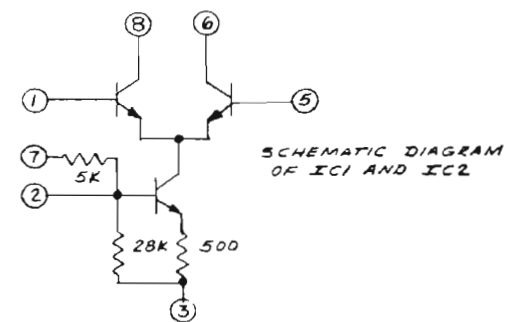

SCHEMATIC DIAGRAM OF IC1 AND IC2

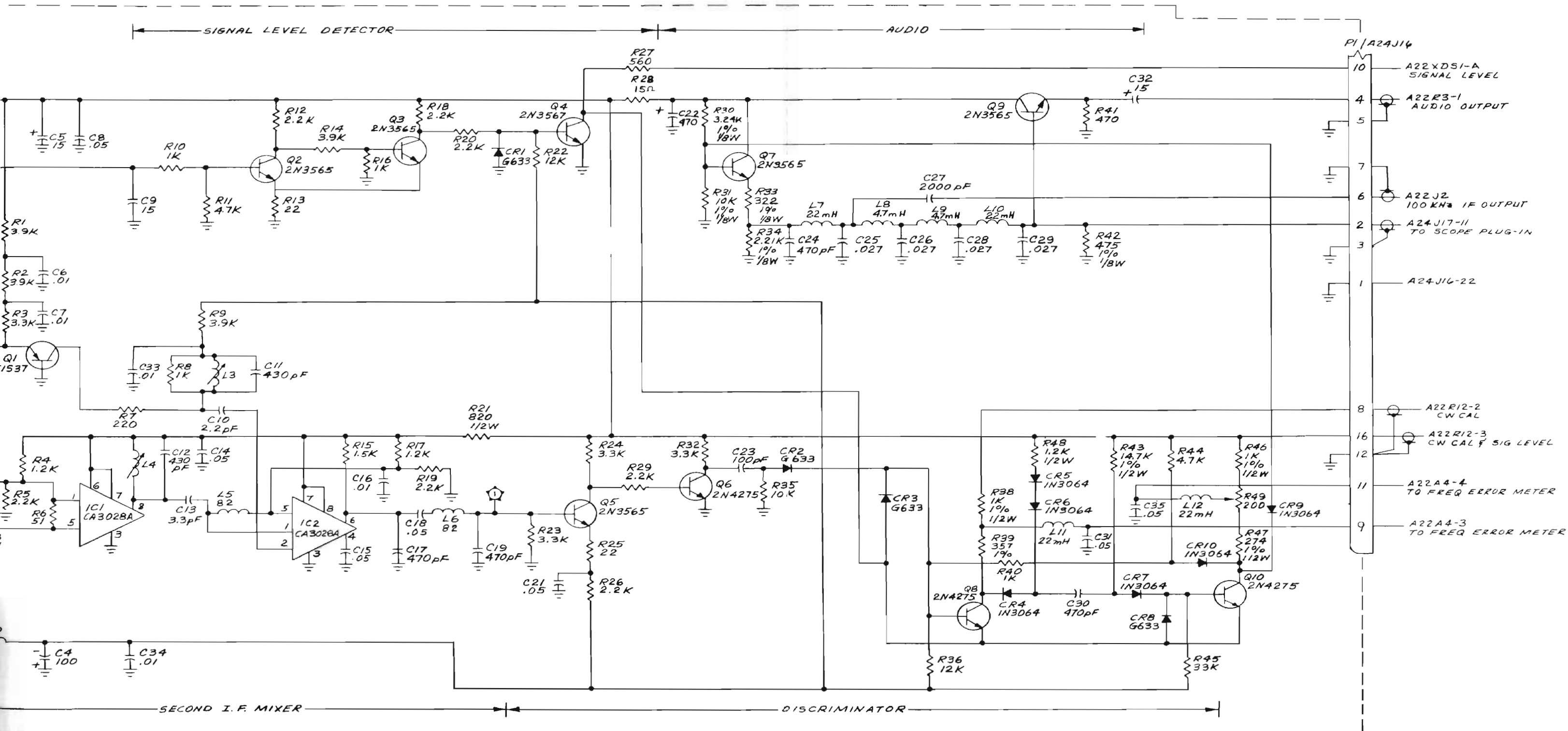

ORS = 1/8W, 5% VALUES IN OHMS UNLESS OTHERWISE NOTED.
 TORS = VALUES IN μ F UNLESS OTHERWISE NOTED.
 DRS = VALUES IN μ H UNLESS OTHERWISE NOTED.
 RRY SELECT. TYPICAL VALUE SHOWN.
 LTAGES ARE DC UNLESS OTHERWISE NOTED.

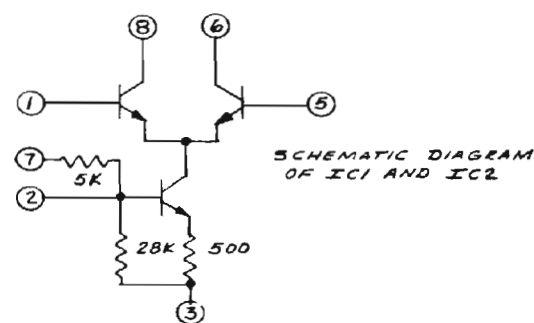

Figure 6-4. Second IF/Discriminator. A5

MASTER OSCILLATOR/DIVIDER/FILTERS, A6

CKT. REF.	DESCRIPTION	CE STOCK NO.	MFR.	MFR. NO.
A6	Master Osc/Divider/Filters P. C. Board Assy	7001-0206	Cushman	
	P. C. Board	1780-0061	Cushman	
	CAPACITORS			
C1	Cer, .05 μ F, +80% -20%, 25V	1005-0014	Erie	5855-000-Y5U0-503Z
C2	Poly, .0012 μ F, \pm 10%, 100V	1008-0016	Sprague	225P82291WA3
C3	Cer, .05 μ F, +80% -20%, 25V	1005-0014	Erie	5855-000-Y5U0-503Z
C4	Cer, .05 μ F, +80% -20%, 25V	1005-0014	Erie	5855-000-Y5U0-503Z
C5	Poly, .0027 μ F, \pm 10%, 100V	1008-0009	Sprague	225P27291
C6	Cer, .05 μ F, +80% -20%, 25V	1005-0014	Erie	5855-000-Y5U0-503Z
C7	Cer, .05 μ F, +80% -20%, 25V	1005-0014	Erie	5855-000-Y5U0-503Z
C8	Mica, 180pF, \pm 5%, 500V	1002-0005	Elmenco	DM15-F-181J
C9	Cer, .05 μ F, +80% -20%, 25V	1005-0014	Erie	5855-000-Y5U0-503Z
C10	Mica, 12pF, \pm 5%, 500V	1002-0017	Elmenco	DM15-C-120J
C11	Mica, 91pF, \pm 5%, 500V	1002-0027	Elmenco	DM15-F-910J
C12	Elect, 15 μ F, +75% -10%, 12V	1013-0015	Sprague	30D156G012BA2
C13	Mica, 91pF, \pm 5%, 500V	1002-0027	Elmenco	DM15-F-910J
C14	Cer, .05 μ F, +80% -20%, 25V	1005-0014	Erie	5855-000-Y5U0-503Z
C15	Cer, .05 μ F, +80% -20%, 25V	1005-0014	Erie	5855-000-Y5U0-503Z
C16	Cer, .05 μ F, +80% -20%, 25V	1005-0014	Erie	5855-000-Y5U0-503Z
C17	Mica, 390pF, \pm 5%, 500V	1002-0033	Elmenco	DM15-F-391J
C18	Mica, 12pF, \pm 5%, 500V	1002-0017	Elmenco	DM15-C-120J
C19	Cer, .05 μ F, +80% -20%, 25V	1005-0014	Erie	5855-000-Y5U0-503Z
C20	Mica, 390pF, \pm 5%, 500V	1002-0033	Elmenco	DM15-F-391J
C21	Mica, 10pF, \pm 5%, 500V	1002-0016	Elmenco	DM15-C-100J
C22	Cer, .05 μ F, +80% -20%, 25V	1005-0014	Erie	5855-000-Y5U0-503Z
C23	Cer, .05 μ F, +80% -20%, 25V	1005-0014	Erie	5855-000-Y5U0-503Z
C24	Cer, .05 μ F, +80% -20%, 25V	1005-0014	Erie	5855-000-Y5U0-503Z
C25	Cer, .05 μ F, +80% -20%, 25V	1005-0014	Erie	5855-000-Y5U0-503Z
C26	Cer, .05 μ F, +80% -20%, 25V	1005-0014	Erie	5855-000-Y5U0-503Z
C27	Mica, 390pF, \pm 5%, 500V	1002-0033	Elmenco	DM15-F-391J
C28	Mica, 12pF, \pm 5%, 500V	1002-0017	Elmenco	DM15-C-120J
C29	Mica, 390pF, \pm 5%, 500V	1002-0033	Elmenco	DM15-F-391J
C30	Mica, 27pF, \pm 5%, 500V	1002-0008	Elmenco	DM15-E-270J
C31	Cer, .05 μ F, +80% -20%, 25V	1005-0014	Erie	5855-000-Y5U0-503Z
C32	Cer, .05 μ F, +80% -20%, 25V	1005-0014	Erie	5855-000-Y5U0-503Z
C33	Cer, .05 μ F, +80% -20%, 25V	1005-0014	Erie	5855-000-Y5U0-503Z
C34	Mica, 390pF, \pm 5%, 500V	1002-0033	Elmenco	DM15-F-391J
C35	Mica, 12pF, \pm 5%, 500V	1002-0017	Elmenco	DM15-C-120J
C36	Cer, .05 μ F, +80% -20%, 25V	1005-0014	Erie	5855-000-Y5U0-503Z
C37	Cer, .05 μ F, +80% -20%, 25V	1005-0014	Erie	5855-000-Y5U0-503Z
C38	Cer, .05 μ F, +80% -20%, 25V	1005-0014	Erie	5855-000-Y5U0-503Z
C39	Cer, .05 μ F, +80% -20%, 25V	1005-0014	Erie	5855-000-Y5U0-503Z
C40	Mica, 390pF, \pm 5%, 500V	1002-0033	Elmenco	DM15-F-391J
C41	Mica, 12pF, \pm 5%, 500V	1002-0017	Elmenco	DM15-C-120J
C42	Cer, .05 μ F, +80% -20%, 25V	1005-0014	Erie	5855-000-Y5U0-503Z
C43	Cer, .05 μ F, +80% -20%, 25V	1005-0014	Erie	5855-000-Y5U0-503Z
C44	Mica, 390pF, \pm 5%, 500V	1002-0033	Elmenco	DM15-F-391J
C45	Mica, 10pF, \pm 5%, 500V	1002-0016	Elmenco	DM15-C-100J
C46	Cer, .05 μ F, +80% -20%, 25V	1005-0014	Erie	5855-000-Y5U0-503Z
C47	Tant, 10 μ F, \pm 10%, 20V	1011-0007	Kemet	K10C20K
C48	Cer, .01 μ F, +80 -20%, 25V	1005-0013	Erie	5835-512-Y5U-103Z

MASTER OSCILLATOR/DIVIDER/FILTERS (cont). A6

CKT. REF.	DESCRIPTION	CE STOCK NO.	MFR.	MFR. NO.
COILS				
L1	RF Choke, 680 μ H, \pm 5%	1585-0023	Delevan	1537-08
L2	RF Choke, 220 μ H, \pm 5%	1585-0018	Delevan	1537-92
L3	RF Choke, 220 μ H, \pm 5%	1585-0018	Delevan	1537-92
L4	Var. Inductor, 4 turns	B1596-0010	Cushman	
L5	Var. Inductor, 8 turns	B1596-0011	Cushman	
L6	Var. Inductor, 4 turns	B1596-0010	Cushman	
L7	Var. Inductor, 8 turns	B1596-0011	Cushman	
L8	Var. Inductor, 4 turns	B1596-0010	Cushman	
L9	RF Choke, 220 μ H, \pm 5%	1585-0018	Delevan	1537-92
L10	Var. Inductor, 4 turns	B1596-0010	Cushman	
L11	Var. Inductor, 4 turns	B1596-0010	Cushman	
L12	RF Choke, 220 μ H, \pm 5%	1585-0018	Delevan	1537-92
L13	RF Choke, 220 μ H, \pm 5%	1585-0018	Delevan	1537-92
DIODES				
CR1	Si, Zener, 6.8V, \pm 20%	1281-0007	Motorola	1N957
CR2	Not used			
CR3	Si, 1N3064	1281-0013	Transitron	1N3064
INTEGRATED CIRCUITS				
IC1	TTL Dual Flip-Flop	2025-0005	T. I.	SN7476N
IC2	Not used			
IC3	Quad 2-input Pos. NAND Gate	2025-0003	T. I.	SN7400N
RESISTORS				
R1	Comp, 10k Ω , \pm 5%, 1/4W	1066-1035	Allen-Bradley	CB1035
R2	Comp, 10k Ω , \pm 5%, 1/4W	1066-1035	Allen-Bradley	CB1035
R3	Comp, 1.5k Ω , \pm 5%, 1/4W	1066-1525	Allen-Bradley	CB1525
R4	Comp, 2.2k Ω , \pm 5%, 1/4W	1066-2225	Allen-Bradley	CB2225
R5	Comp, 10k Ω , \pm 5%, 1/4W	1066-1035	Allen-Bradley	CB1035
R6	Comp, 27k Ω , \pm 5%, 1/4W	1066-2735	Allen-Bradley	CB2735
R7	Comp, 680 Ω , \pm 5%, 1/4W	1066-6815	Allen-Bradley	CB6815
R8	Comp, 1.5k Ω , \pm 5%, 1/4W	1066-1525	Allen-Bradley	CB1525
R9	Comp, 1.2k Ω , \pm 5%, 1/4W	1066-1225	Allen-Bradley	CB1225
R10	Comp, 220 Ω , \pm 5%, 1/4W	1066-2215	Allen-Bradley	CB2215
R11	Comp, 100 Ω , \pm 5%, 1/4W	1066-1015	Allen-Bradley	CB1015
R12	Comp, 100 Ω , \pm 5%, 1/4W	1066-1015	Allen-Bradley	CB1015
R13	Comp, 5.1k Ω , \pm 5%, 1/4W	1066-5125	Allen-Bradley	CB5125
R14	Comp, 560 Ω , \pm 5%, 1/4W	1066-5615	Allen-Bradley	CB5615
R15	Comp, 3.9k Ω , \pm 5%, 1/4W	1066-3925	Allen-Bradley	CB3925
R16	Comp, 560 Ω , \pm 5%, 1/4W	1066-5615	Allen-Bradley	CB5615
R17	Comp, 10k Ω , \pm 5%, 1/4W	1066-1035	Allen-Bradley	CB1035
R18	Comp, 10k Ω , \pm 5%, 1/4W	1066-1035	Allen-Bradley	CB1035
R19	Comp, 3.3k Ω , \pm 5%, 1/4W	1066-3325	Allen-Bradley	CB3325
R20	Comp, 3.9k Ω , \pm 5%, 1/4W	1066-3925	Allen-Bradley	CB3925
R21	Comp, 3.9k Ω , \pm 5%, 1/4W	1066-3925	Allen-Bradley	CB3925
R22	Comp, 3.3k Ω , \pm 5%, 1/4W	1066-3325	Allen-Bradley	CB3325
R23	Comp, 10k Ω , \pm 5%, 1/4W	1066-1035	Allen-Bradley	CB1035
R24	Comp, 10k Ω , \pm 5%, 1/4W	1066-1035	Allen-Bradley	CB1035
R25	Comp, 3.9k Ω , \pm 5%, 1/4W	1066-3925	Allen-Bradley	CB3925
R26	Comp, 10k Ω , \pm 5%, 1/4W	1066-1035	Allen-Bradley	CB1035
R27	Comp, 10k Ω , \pm 5%, 1/4W	1066-1035	Allen-Bradley	CB1035
R28	Comp, 3.9k Ω , \pm 5%, 1/4W	1066-3925	Allen-Bradley	CB3925
R29	Comp, 5.6k Ω , \pm 5%, 1/4W	1066-5625	Allen-Bradley	CB5625
R30	Comp, 5.6k Ω , \pm 5%, 1/4W	1066-5625	Allen-Bradley	CB5625
R31	Comp, 1k Ω , \pm 5%, 1/4W	1066-1025	Allen-Bradley	CB1025

MASTER OSCILLATOR/DIVIDER/FILTERS (cont). A6

CKT. REF.	DESCRIPTION	CE STOCK NO.	MFR.	MFR. NO.
R32	Comp, 820 Ω , \pm 5%, 1/4W	1066-8215	Allen-Bradley	CB8215
R33	Comp, 820 Ω , \pm 5%, 1/4W	1066-8215	Allen-Bradley	CB8215
R34	Comp, 200 Ω , \pm 5%, 1/4W	1066-2015	Allen-Bradley	CB2015
R35	Comp, 120 Ω , \pm 5%, 1/4W	1066-1215	Allen-Bradley	CB1215
TRANSISTORS				
Q1	Si, NPN, 2N3563	1272-0022	Fairchild	2N3563
Q2	Si, PNP, 2N4121	1272-0023	Fairchild	2N4121
Q3	Si, NPN, 2N3563	1272-0022	Fairchild	2N3563
Q4	Si, NPN, 2N3563	1272-0022	Fairchild	2N3563
Q5	Si, PNP, TIS 37	1271-0003	T.I.	TIS 37
Q6	Si, NPN, 2N3563	1272-0022	Fairchild	2N3563
Q7	Si, PNP, TIS 37	1271-0003	T.I.	TIS 37
Q8	Si, PNP, TIS 37	1271-0003	T.I.	TIS 37
Q9	Si, PNP, TIS 37	1271-0003	T.I.	TIS 37
Q10	Si, NPN, 2N4275	1272-0016	Fairchild	2N4275
Q11	Si, NPN, 2N4275	1272-0016	Fairchild	2N4275
Q12	Si, NPN, 2N4275	1272-0016	Fairchild	2N4275

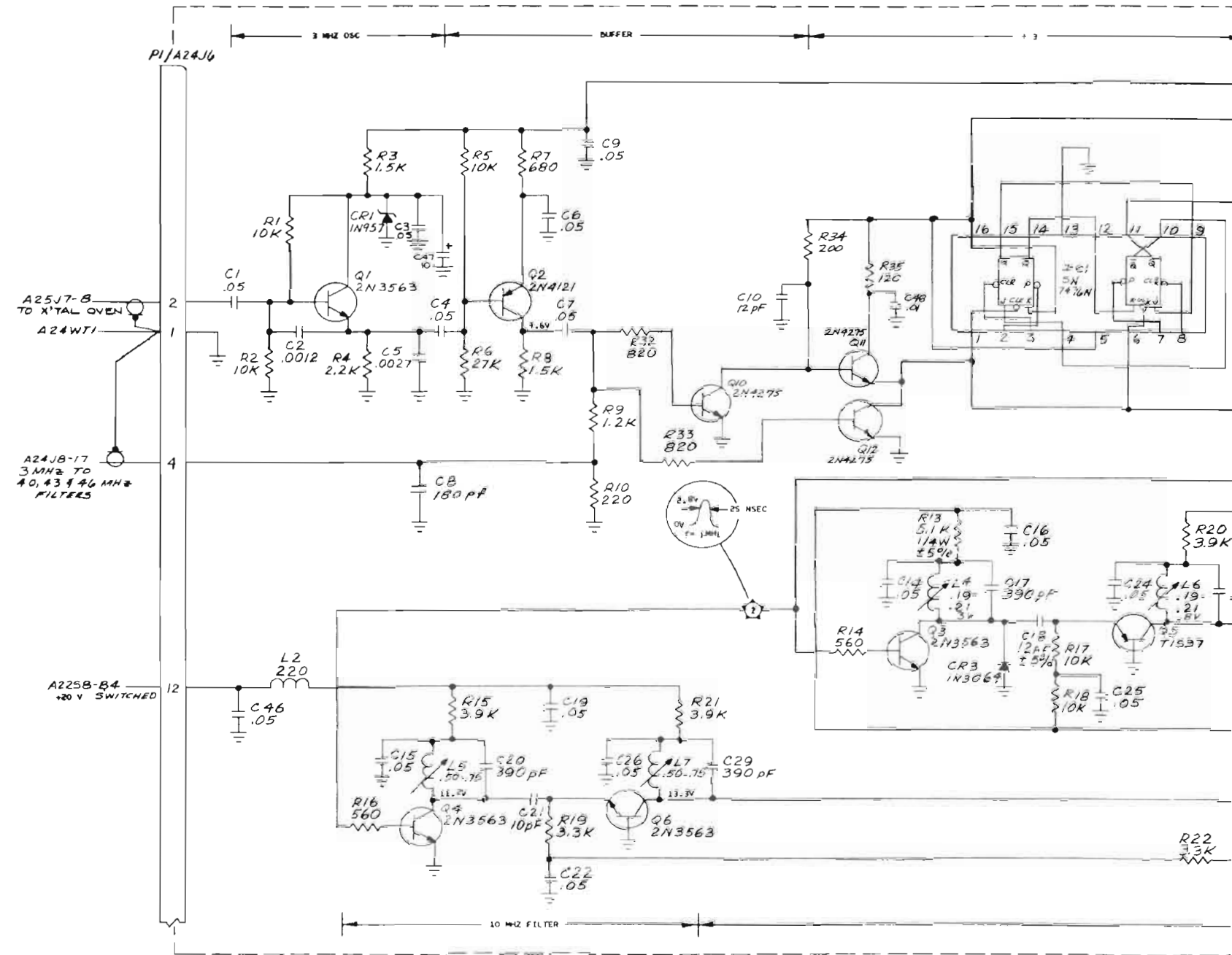
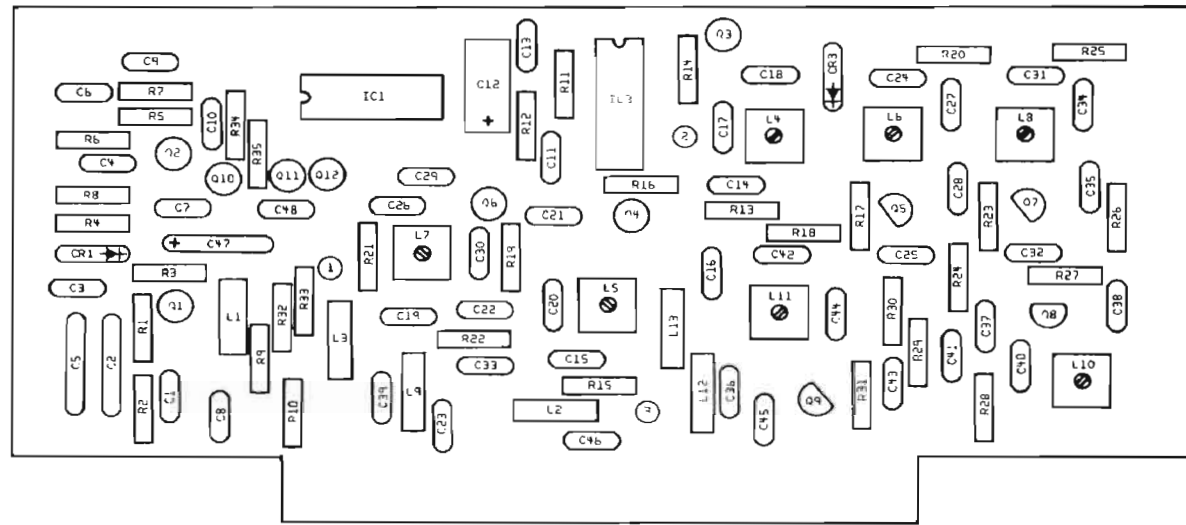

- NOTE:
1. RESISTORS - 1/4W, 5% VALUES IN OHMS UNLESS OTHERWISE NOTED.
 2. CAPACITORS - VALUES IN PF UNLESS OTHERWISE NOTED.
 3. INDUCTORS - VALUES IN μH UNLESS OTHERWISE NOTED.
 4. *FACTORY SELECT* TYPICAL VALUE SHOWN.
 5. ALL VOLTAGES ARE DC UNLESS OTHERWISE NOTED.

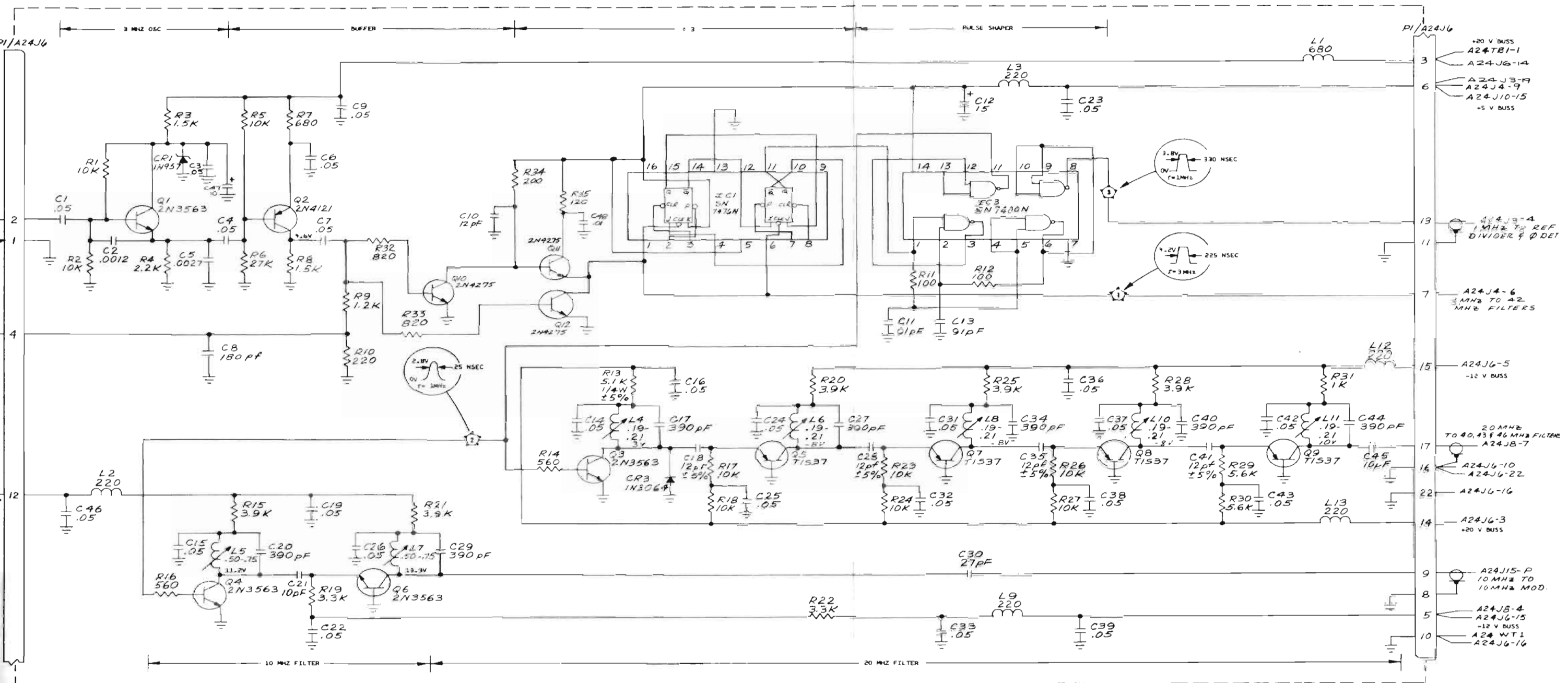

- NOTE:
1. RESISTORS - 1/4W, 5% VALUES IN OHMS UNLESS OTHERWISE NOTED.
 2. CAPACITORS - VALUES IN μ F UNLESS OTHERWISE NOTED.
 3. INDUCTORS - VALUES IN μ H UNLESS OTHERWISE NOTED.
 4. *FACTORY SELECT, TYPICAL VALUE SHOWN.
 5. ALL VOLTAGES ARE DC UNLESS OTHERWISE NOTED.

NOT USED
CR2
IC2

Figure 6-5. Master Oscillator/Divider/Filter. A6

1 kHz-4 kHz MIXER/9.9 MHz FILTER. A7

CKT. REF.	DESCRIPTION	CE STOCK NO.	MFR.	MFR. NO.
A7	1 to 4 MHz and 9.9 MHz Mixers Board Assy	7001-0207	Cushman	
	Printed Circuit Board	1780-0062	Cushman	
CAPACITORS				
C1	Cer, .01 μ F, +80% -20%, 25V	1005-0013	Erie	5835-512-Y5U-103Z
C2	Cer, .01 μ F, +80% -20%, 25V	1005-0013	Erie	5835-512-Y5U-103Z
C3	Cer, .05 μ F, +80% -20%, 25V	1005-0014	Erie	5855-505-Y5U0-503Z
C4	Cer, .05 μ F, +80% -20%, 25V	1005-0014	Erie	5855-505-Y5U0-503Z
C5	Mica, 560pF, \pm 5%, 300V	1002-0037	Elmenco	DM15-F-561J
C6	Cer, .05 μ F, +80% -20%, 25V	1005-0014	Erie	5855-505-Y5U0-503Z
C7	Cer, .05 μ F, +80% -20%, 25V	1005-0014	Erie	5855-505-Y5U0-503Z
C8	Cer, 9-35pF, 350V	1001-0006	Erie	538-002-94D
C9	Mica, 27pF, \pm 5%, 500V	1002-0008	Elmenco	DM15-E-270J
C10	Cer, .002 μ F, \pm 20%, 500V	1005-0003	Erie	831-596-Z5U-202M
C11	Cer, .05 μ F, +80% -20%, 25V	1005-0014	Erie	5855-505-Y5U0-503Z
C12	Mica, 510pF, \pm 5%, 500V	1002-0036	Elmenco	DM15-F-511J
C13	Cer, .05 μ F, +80% -20%, 25V	1005-0014	Erie	5855-505-Y5U0-503Z
C14	Mica, 27pF, \pm 5%, 500V	1002-0008	Elmenco	DM15-E-270J
C15	Cer, .05 μ F, +80% -20%, 25V	1005-0014	Erie	5855-505-Y5U0-503Z
C16	Mica, 15pF, \pm 5%, 500V	1002-0001	Elmenco	DM15-C-150J
C17	Elect, 1.0 μ F, \pm 10%, 25V	1013-0004	Sprague	30D105G025BA5
C18	Mica, 27pF, \pm 5%, 500V	1002-0008	Elmenco	DM15-E-270J
C19	Elect, 15 μ F, \pm 10%, 25V	1013-0005	Sprague	30D156G025BB5
C20	Cer, .05 μ F, +80% -20%, 25V	1005-0014	Erie	5855-505-Y5U0-503Z
C21	Mica, 15pF, \pm 5%, 500V	1002-0001	Elmenco	DM15-C-150J
C22	Mica, 510pF, \pm 5%, 500V	1002-0036	Elmenco	DM15-F-511J
C23	Cer, .05 μ F, +80% -20%, 25V	1005-0014	Erie	5855-505-Y5U0-503Z
C24	Cer, .05 μ F, +80% -20%, 25V	1005-0014	Erie	5855-505-Y5U0-503Z
C25	Elect, 15 μ F, \pm 10%, 25V	1013-0005	Sprague	30D156G025BB5
C26	Cer, .05 μ F, +80% -20%, 25V	1005-0014	Erie	5855-505-Y5U0-503Z
C27	Cer, .05 μ F, +80% -20%, 25V	1005-0014	Erie	5855-505-Y5U0-503Z
C28	Mica, 12pF, \pm 5%, 500V	1002-0017	Elmenco	DM15-C-120J
C29	Mica, 510pF, \pm 5%, 500V	1002-0036	Elmenco	DM15-F-511J
C30	Cer, .05 μ F, +80% -20%, 25V	1005-0014	Erie	5855-505-Y5U0-503Z
C31	Cer, .05 μ F, +80% -20%, 25V	1005-0014	Erie	5855-505-Y5U0-503Z
C32	Elect, 100 μ F, \pm 10%, 25V	1013-0003	Sprague	30D107G025DD5
C33	Elect, 1.0 μ F, \pm 10%, 25V	1013-0004	Sprague	30D105G025BA5
C34	Elect, 1.0 μ F, \pm 10%, 25V	1013-0004	Sprague	30D105G025BA5
C35	Mica, 620pF, \pm 5%, 300V	1002-0038	Elmenco	DM15-F-621J
C36	Poly, .0082 μ F, \pm 10%, 100V	1008-0015	Elmenco	225-P82291
C37	Cer, .05 μ F, +80% -20%, 25V	1005-0014	Erie	5855-505-Y5U0-503Z
C38	Cer, .05 μ F, +80% -20%, 25V	1005-0014	Erie	5855-505-Y5U0-503Z
C39	Poly, .0082 μ F, \pm 10%, 100V	1008-0015	Elmenco	225-P82291
C40	Mica, 430pF, \pm 5%, 500V	1002-0034	Elmenco	DM15-F-431J
C41	Cer, .05 μ F, +80% -20%, 25V	1005-0014	Erie	5855-505-Y5U0-503Z
C42	Cer, .01 μ F, +80% -20%, 25V	1005-0013	Erie	5835-512-Y5U-103Z
COILS				
L1	RF Choke, 680 μ H, \pm 5%	1585-0023	Delevan	2500-20
L2	RF Choke, 680 μ H, \pm 5%	1585-0023	Delevan	2500-20
L3	Var. Inductor, 2.2-5.1 μ H	1596-0004	TRW	20211-R2
L4	Var. Inductor, 2.2-5.1 μ H	1596-0004	TRW	20211-R2
L5	Var. Inductor, 2.2-5.1 μ H	1596-0004	TRW	20211-R2
L6	Var. Inductor, 2.2-5.1 μ H	1596-0004	TRW	20211-R2
L7	Var. Inductor, 0.5-0.75 μ H	1596-0011	TRW	21024
L8	RF Choke, 5.6 μ H, \pm 10%	1585-0028	Delevan	1537-30

1 kHz-4 kHz MIXER/9.9 MHz FILTER (cont). A7

CKT. REF.	DESCRIPTION	CE STOCK NO.	MFR.	MFR. NO.
DIODES				
CR1	Ge, G633	1282-0005	ITT	G633
CR2	Ge, G633	1282-0005	ITT	G633
RESISTORS				
R1	Comp, 27k Ω , $\pm 5\%$, 1/4W	1066-2735	Allen-Bradley	CB2735
R2	Comp, 8.2k Ω , $\pm 5\%$, 1/4W	1066-8225	Allen-Bradley	CB8225
R3	Comp, 10k Ω , $\pm 5\%$, 1/4W	1066-1035	Allen-Bradley	CB1035
R4	Comp, 10k Ω , $\pm 5\%$, 1/4W	1066-1035	Allen-Bradley	CB1035
R5	Comp, 1k Ω , $\pm 5\%$, 1/4W	1066-1025	Allen-Bradley	CB1025
R6	Comp, 1k Ω , $\pm 5\%$, 1/4W	1066-1025	Allen-Bradley	CB1025
R7	Comp, 2.2k Ω , $\pm 5\%$, 1/4W	1066-2225	Allen-Bradley	CB2225
R8	Comp, 120 Ω , $\pm 5\%$, 1/4W	1066-1215	Allen-Bradley	CB1215
R9	Comp, 3.9k Ω , $\pm 5\%$, 1/4W	1066-3925	Allen-Bradley	CB3925
R10	Comp, 150 Ω , $\pm 5\%$, 1/4W	1066-1515	Allen-Bradley	CB1515
R11	Comp, FSV, $\pm 5\%$, 1/4W	1066-xxxx		
R12	Comp, 680 Ω , $\pm 5\%$, 1/4W	1066-6815	Allen-Bradley	CB6815
R13	Comp, 120 Ω , $\pm 5\%$, 1/4W	1066-1215	Allen-Bradley	CB1215
R14	Comp, 10k Ω , $\pm 5\%$, 1/4W	1066-1035	Allen-Bradley	CB1035
R15	Comp, 10k Ω , $\pm 5\%$, 1/4W	1066-1035	Allen-Bradley	CB1035
R16	Comp, 3.9k Ω , $\pm 5\%$, 1/4W	1066-3925	Allen-Bradley	CB3925
R17	Comp, 1.2k Ω , $\pm 5\%$, 1/4W	1066-1225	Allen-Bradley	CB1225
R18	Comp, 2.7k Ω , $\pm 5\%$, 1/4W	1066-2725	Allen-Bradley	CB2725
R19	Comp, 100 Ω , $\pm 5\%$, 1/4W	1066-1015	Allen-Bradley	CB1015
R20	Comp, 1k Ω , $\pm 5\%$, 1/4W	1066-1025	Allen-Bradley	CB1025
R21	Comp, 10k Ω , $\pm 5\%$, 1/4W	1066-1035	Allen-Bradley	CB1035
R22	Comp, 10k Ω , $\pm 5\%$, 1/4W	1066-1035	Allen-Bradley	CB1035
R23	Comp, 3.9k Ω , $\pm 5\%$, 1/4W	1066-3925	Allen-Bradley	CB3925
R24	Comp, 1k Ω , $\pm 5\%$, 1/4W	1066-1025	Allen-Bradley	CB1025
R25	Comp, 1.2k Ω , $\pm 5\%$, 1/4W	1066-1225	Allen-Bradley	CB1225
R26	Comp, 6.8k Ω , $\pm 5\%$, 1/4W	1066-6825	Allen-Bradley	CB6825
R27	Comp, 8.2k Ω , $\pm 5\%$, 1/4W	1066-8225	Allen-Bradley	CB8225
R28	Comp, 560 Ω , $\pm 5\%$, 1/4W	1066-5615	Allen-Bradley	CB5615
R29	Comp, 330 Ω , $\pm 5\%$, 1/4W	1066-3315	Allen-Bradley	CB3315
R30	Comp, 1k Ω , $\pm 5\%$, 1/4W	1066-1025	Allen-Bradley	CB1025
R31	Comp, 82 Ω , $\pm 5\%$, 1/4W	1066-8205	Allen-Bradley	CB8205
R32	Comp, 2.2k Ω , $\pm 5\%$, 1/4W	1066-2225	Allen-Bradley	CB2225
R33	Comp, 8.2k Ω , $\pm 5\%$, 1/4W	1066-8225	Allen-Bradley	CB8225
R34	Comp, 10k Ω , $\pm 5\%$, 1/4W	1066-1035	Allen-Bradley	CB1035
R35	Comp, 12k Ω , $\pm 5\%$, 1/4W	1066-1235	Allen-Bradley	CB1235
R36	Comp, 22k Ω , $\pm 5\%$, 1/4W	1066-2235	Allen-Bradley	CB2235
R37	Comp, 2.7k Ω , $\pm 5\%$, 1/4W	1066-2725	Allen-Bradley	CB2725
TRANSFORMER				
T1	Toroid, 9 turns #26, 4 turns #26	1579-0007	Cushman	
TRANSISTORS				
Q1	Si, NPN, 2N3563	1272-0022	Fairchild	2N3563
Q2	Si, NPN, 2N3563	1272-0022	Fairchild	2N3563
Q3	Si, PNP, 2N4121	1272-0023	Fairchild	2N4121
Q4	Si, NPN, 2N3642	1272-0018	Fairchild	2N3642
Q5	Si, PNP, TIS 37	1271-0003	T. I.	TIS 37
Q6	Si, PNP, TIS 37	1271-0003	T. I.	TIS 37
Q7	Si, PNP, TIS 37	1271-0003	T. I.	TIS 37
Q8	Si, PNP, TIS 37	1271-0003	T. I.	TIS 37
Q9	Si, NPN, 2N3563	1272-0022	Fairchild	2N3563

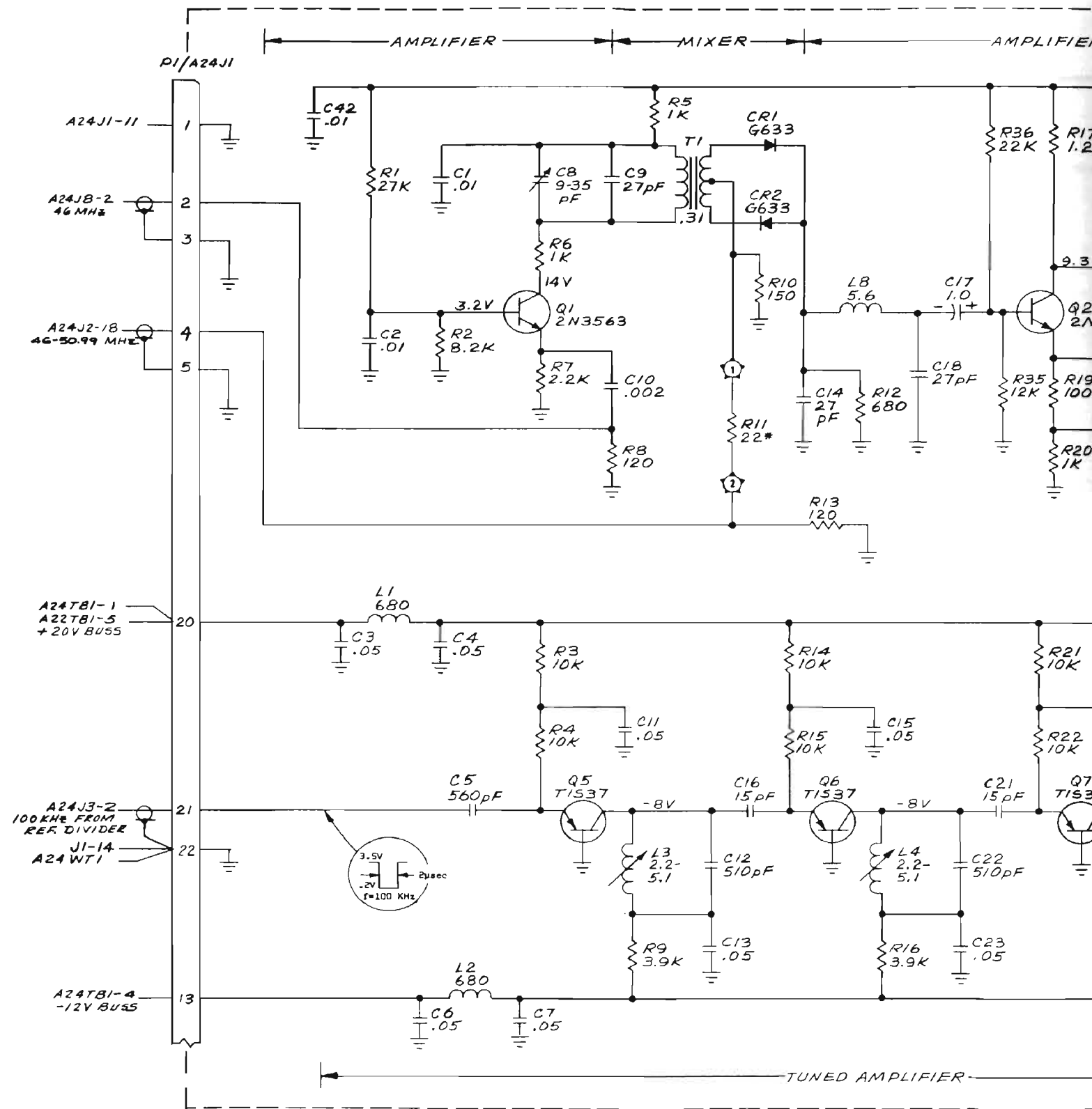
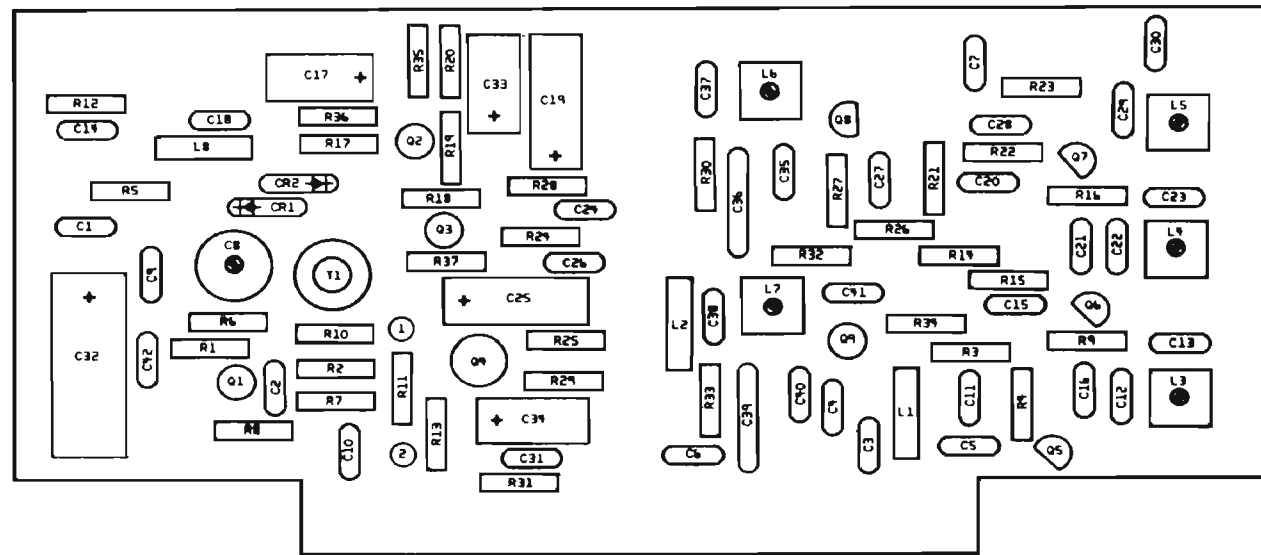

NOTE:
 1. RESISTORS - 1/4W, 5% VALUES IN OHMS UNLESS OTHERWISE NOTED.
 2. CAPACITORS - VALUES IN μ F UNLESS OTHERWISE NOTED.
 3. INDUCTORS - VALUES IN μ H UNLESS OTHERWISE NOTED.
 4. * FACTORY SELECT. TYPICAL VALUE SHOWN.
 5. ALL VOLTAGES ARE DC UNLESS OTHERWISE NOTED.

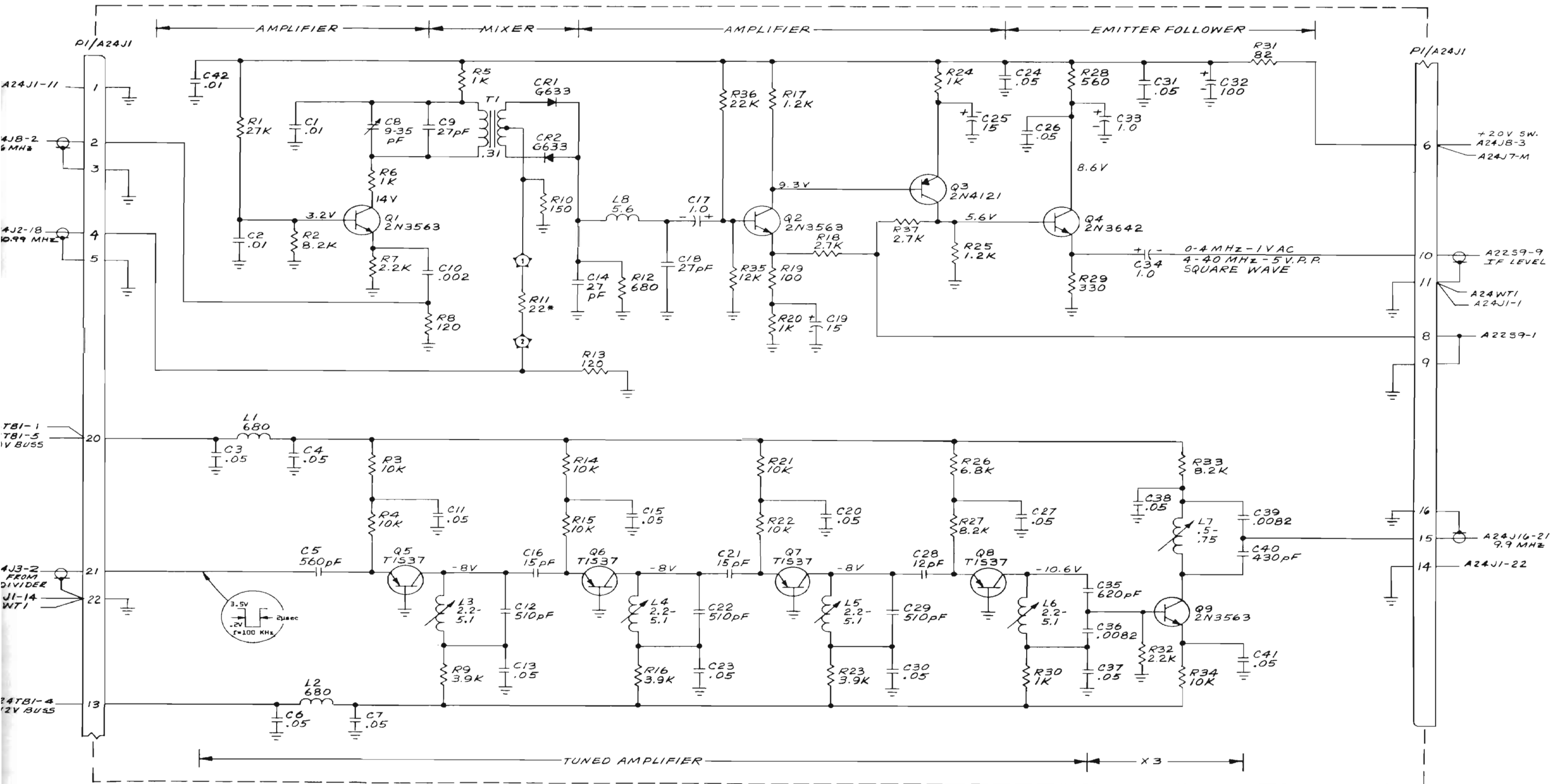

NOTE:
 1. RESISTORS - 1/4W, 5% VALUES IN OHMS UNLESS OTHERWISE NOTED.
 2. CAPACITORS - VALUES IN μ F UNLESS OTHERWISE NOTED.
 3. INDUCTORS - VALUES IN μ H UNLESS OTHERWISE NOTED.
 4. *FACTORY SELECT. TYPICAL VALUE SHOWN.
 5. ALL VOLTAGES ARE DC UNLESS OTHERWISE NOTED.

Figure 6-6. 1 kHz-4 kHz Mixer/9.9 MHz Filter. A7

46.00-50.99 MHz BALANCED MIXER. A8

CKT. REF.	DESCRIPTION	CE STOCK NO.	MFR.	MFR. NO.
A8	46.00-50.99 MHz Balanced Mixer, P. C. Board Assy	7001-0208	Cushman	
	Printed Circuit Board	1780-0065	Cushman	
CAPACITORS				
C1	Cer, .002 μ F, \pm 20%, 500V	1005-0003	Erie	831-596-Z5U-202M
C2	Cer, .002 μ F, \pm 20%, 500V	1005-0003	Erie	831-596-Z5U-202M
C3	Cer, .002 μ F, \pm 20%, 500V	1005-0003	Erie	831-596-Z5U-202M
C4	Mica, 33pF, \pm 5%, 500V	1002-0024	Elmenco	DM15-E-330J
C5	Mica, 68pF, \pm 5%, 500V	1002-0013	Elmenco	DM15-E-680J
C6	Cer, 2-8pF, 350V	1001-0010	Erie	538-006A
C7	Mica, FSV, \pm 5%, 500V	1002-xxxx	Elmenco	DM15-C-xxxxD
C8	Mica, 100pF, \pm 5%, 500V	1002-0011	Elmenco	DM15-F-101J
C9	Mica, 68pF, \pm 5%, 500V	1002-0013	Elmenco	DM15-E-680J
C10	Cer, 5.0pF, \pm .25pF, 500V	1005-0112	Erie	301-000-COHO-509C
C11	Mica, 33pF, \pm 5%, 500V	1002-0024	Elmenco	DM15-E-330J
C12	Cer, 5.0pF, \pm .25pF, 500V	1005-0112	Erie	301-000-COHO-509C
C13	Mica, 43pF, \pm 5%, 500V	1002-0046	Elmenco	DM15-E-430J
C14	Mica, 12pF, \pm 5%, 500V	1002-0017	Elmenco	DM15-C-120J
C15	Cer, .002 μ F, \pm 20%, 500V	1005-0003	Erie	831-596-Z5U-202M
C16	Cer, .002 μ F, \pm 20%, 500V	1005-0003	Erie	831-596-Z5U-202M
C17	Mica, 43pF, \pm 5%, 500V	1002-0046	Elmenco	DM15-E-430J
C18	Cer, 6.8pF, \pm .25pF, 500V	1005-0006	Erie	301-000-COHO-689C
C19	Mica, 39pF, \pm 5%, 500V	1002-0018	Elmenco	DM15-E-390J
C20	Mica, 15pF, \pm 5%, 500V	1002-0001	Elmenco	DM15-C-150J
C21	Cer, .002 μ F, \pm 20%, 500V	1005-0003	Erie	831-596-Z5U-202M
C22	Cer, .002 μ F, \pm 20%, 500V	1005-0003	Erie	831-596-Z5U-202M
C23	Cer, 8.2pF, \pm .25pF, 500V	1005-0043	Erie	301-000-COHO-829C
C24	Mica, 43pF, \pm 5%, 500V	1002-0046	Elmenco	DM15-E-430J
C25	Mica, 68pF, \pm 5%, 500V	1002-0013	Elmenco	DM15-E-680J
C26	Mica, 120pF, \pm 5%, 500V	1002-0010	Elmenco	DM15-F-121J
C27	Cer, .002 μ F, \pm 20%, 500V	1005-0003	Erie	831-596-Z5U-202M
C28	Cer, .002 μ F, \pm 20%, 500V	1005-0003	Erie	831-596-Z5U-202M
C29	Elect, 15 μ F, \pm 10%, 25V	1013-0005	Sprague	30D156G025BB5
C30	Cer, .05 μ F, +80% -20%, 25V	1005-0014	Erie	5855-505-Y5U0-503Z
C31	Cer, .05 μ F, +80% -20%, 25V	1005-0014	Erie	5855-505-Y5U0-503Z
C32	Cer, .05 μ F, +80% -20%, 25V	1005-0014	Erie	5855-505-Y5U0-503Z
C33	Cer, .05 μ F, +80% -20%, 25V	1005-0014	Erie	5855-505-Y5U0-503Z
C34	Mica, 56pF, \pm 5%, 500V	1002-0019	Elmenco	DM15-E-560J
C35	Mica, 330pF, \pm 5%, 500V	1002-0032	Elmenco	DM15-F-331J
C36	Mica, 270pF, \pm 5%, 500V	1002-0031	Elmenco	DM15-F-271J
C37	Mica, 470pF, \pm 5%, 500V	1002-0035	Elmenco	DM15-F-471J
C38	Mica, 220pF, \pm 5%, 500V	1002-0029	Elmenco	DM15-F-221J
C39	Mica, 430pF, \pm 5%, 500V	1002-0034	Elmenco	DM15-F-431J
C40	Mica, 270pF, \pm 5%, 500V	1002-0031	Elmenco	DM15-F-271J
C41	Elect, 15 μ F, \pm 10%, 25V	1013-0005	Sprague	30D156G025BB5
C42	Elect, 15 μ F, \pm 10%, 25V	1013-0005	Sprague	30D156G025BB5
C43	Cer, .05 μ F, +80% -20%, 25V	1005-0014	Erie	5855-505-Y5U0-503Z
COILS				
L1	RF Choke, 12 μ H, \pm 10%	1585-0011	Delevan	1537-38
L2	Var. Inductor, 0.19-0.21 μ H	1596-0010	Cushman	
L3	Var. Inductor, 0.28-0.34 μ H	7050-0021	Cushman	
L4	Var. Inductor, 0.28-0.34 μ H	7050-0021	Cushman	
L5	Var. Inductor, 0.28-0.34 μ H	7050-0021	Cushman	

46.00-50.99 MHz BALANCED MIXER (cont). A8

CKT. REF.	DESCRIPTION	CE STOCK NO.	MFR.	MFR. NO.
L6	Var. Inductor, 0.28-0.34μH	7050-0021	Cushman	
L7	Var. Inductor, 0.28-0.34μH	7050-0021	Cushman	
L8	RF Choke, 12μH, ±10%	1585-0011	Delevan	1537-38
L9	Var. Inductor, 0.28-0.34μH	7050-0021	Cushman	
L10	Var. Inductor, 0.28-0.34μH	7050-0021	Cushman	
L11	RF Choke, 12μH, ±10%	1585-0011	Delevan	1537-38
L12	RF Choke, 1μH, ±10%	1585-0027	Delevan	1537-12
L13	RF Choke, .56μH, ±10%	1585-0036	Delevan	1840-07
L14	RF Choke, .68μH, ±10%	1585-0024	Delevan	1537-08
DIODES				
CR1	HP 2800	1283-0001	HPA	5082-2800
CR2	HP 2800	1283-0001	HPA	5082-2800
CR3	HP 2800	1283-0001	HPA	5082-2800
CR4	HP 2800	1283-0001	HPA	5082-2800
CR5	Zener, 9.1V, ±5%, 1N4739A	1281-0027	IRC	1N4739A
INTEGRATED CIRCUITS				
IC1	RF Ampl, CA3028A	2025-0012	RCA	CA3028A
IC2	RF Ampl, CA3028A	2025-0012	RCA	CA3028A
RESISTORS				
R1	Comp, 120Ω, ±5%, 1/4W	1066-1215	Allen-Bradley	CB1215
R2	Not Used			
R3	Comp, 51Ω, ±5%, 1/4W	1066-5105	Allen-Bradley	CB5105
R4	Comp, 2.2kΩ, ±5%, 1/4W	1066-2225	Allen-Bradley	CB2225
R5	Comp, 5.6kΩ, ±5%, 1/4W	1066-5625	Allen-Bradley	CB5625
R6	Comp, 51Ω, ±5%, 1/4W	1066-5105	Allen-Bradley	CB5105
R7	Comp, 270Ω, ±5%, 1/4W	1066-2715	Allen-Bradley	CB2715
R8	Comp, 68Ω, ±5%, 1/4W	1066-6805	Allen-Bradley	CB6805
R9	Comp, 51Ω, ±5%, 1/4W	1066-5105	Allen-Bradley	CB5105
R10	Comp, 5.6kΩ, ±5%, 1/4W	1066-5625	Allen-Bradley	CB5625
R11	Comp, 12kΩ, ±5%, 1/4W	1066-1235	Allen-Bradley	CB1235
R12	Comp, 680Ω, ±5%, 1/4W	1066-6815	Allen-Bradley	CB6815
R13	Comp, 3.9kΩ, ±5%, 1/4W	1066-3925	Allen-Bradley	CB3925
R14	Comp, 1kΩ, ±5%, 1/4W	1066-1025	Allen-Bradley	CB1025
R15	Comp, 51Ω, ±5%, 1/4W	1066-5105	Allen-Bradley	CB5105
R16	Comp, 3.9kΩ, ±5%, 1/4W	1066-3925	Allen-Bradley	CB3925
R17	Comp, 4.7kΩ, ±5%, 1/4W	1066-4725	Allen-Bradley	CB4725
R18	Comp, 470Ω, ±5%, 1/4W	1066-4715	Allen-Bradley	CB4715
R19	Comp, 220Ω, ±5%, 1/4W	1066-2215	Allen-Bradley	CB2215
R20	Comp, 51Ω, ±5%, 1/4W	1066-5105	Allen-Bradley	CB5105
R21	Comp, 330Ω, ±5%, 1/4W	1067-3315	Allen-Bradley	EB3315
R22	Comp, 1kΩ, ±5%, 1/4W	1066-1025	Allen-Bradley	CB1025
R23	Comp, 1.5kΩ, ±5%, 1/4W	1066-1525	Allen-Bradley	CB1525
R24	Comp, 2.2kΩ, ±5%, 1/4W	1066-2225	Allen-Bradley	CB2225
R25	Comp, 2.2kΩ, ±5%, 1/4W	1066-2225	Allen-Bradley	CB2225
R26	Comp, 8.2kΩ, ±5%, 1/4W	1066-8225	Allen-Bradley	CB8225
R27	Pot, 1kΩ, ±10%, 1/4W	1200-0012	Allen-Bradley	F FR102U
R28	Comp, 1.5kΩ, ±5%, 1/4W	1066-1525	Allen-Bradley	CB1525
R29	Pot, 100Ω, ±10%, 3/4W	1215-0009	Beckman	89 PR 100
TRANSFORMERS				
T1	Toroid, Trifilar Coil Assy	C1579-0017	Cushman	
T2	Toroid, Trifilar Coil Assy	C1579-0017	Cushman	

46.00-50.99 MHz BALANCED MIXER (cont). A8

CKT. REF.	DESCRIPTION	CE STOCK NO.	MFR.	MFR. NO.
	TRANSISTORS			
Q1	Si, NPN, 2N3563	1272-0022	Fairchild	2N3563
Q2	Si, NPN, 2N3563	1272-0022	Fairchild	2N3563
Q3	Si, NPN, 2N3563	1272-0022	Fairchild	2N3563
Q4	Si, NPN, 2N3563	1272-0022	Fairchild	2N3563

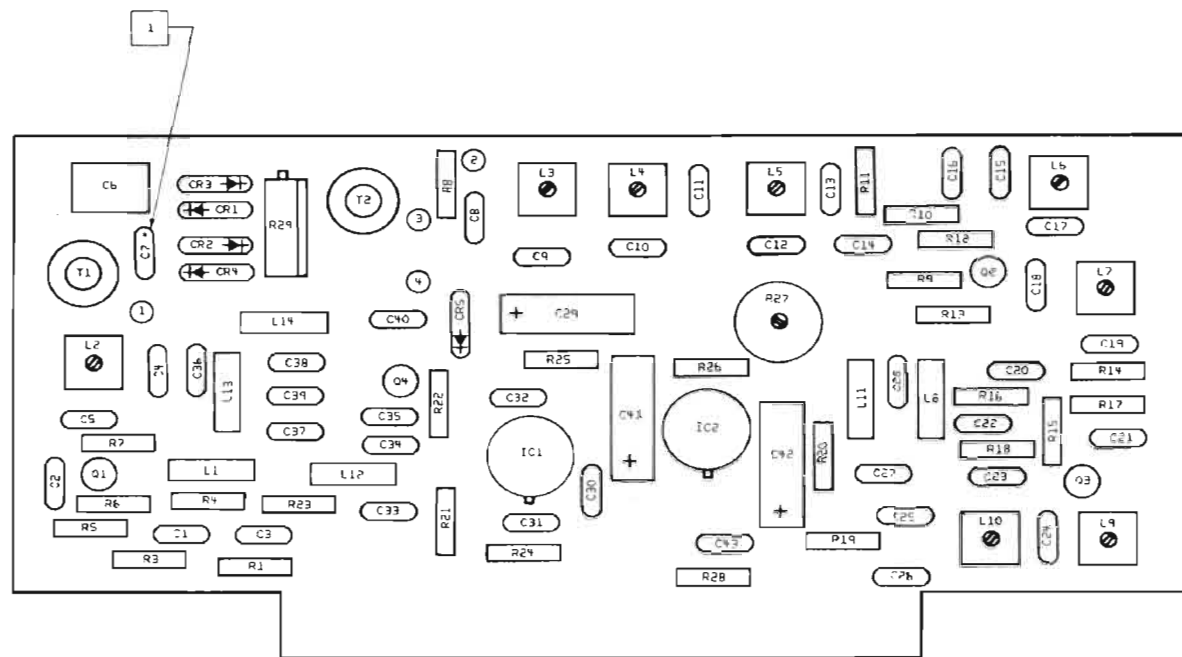

NOTE: 1* DENOTES 1/2W.

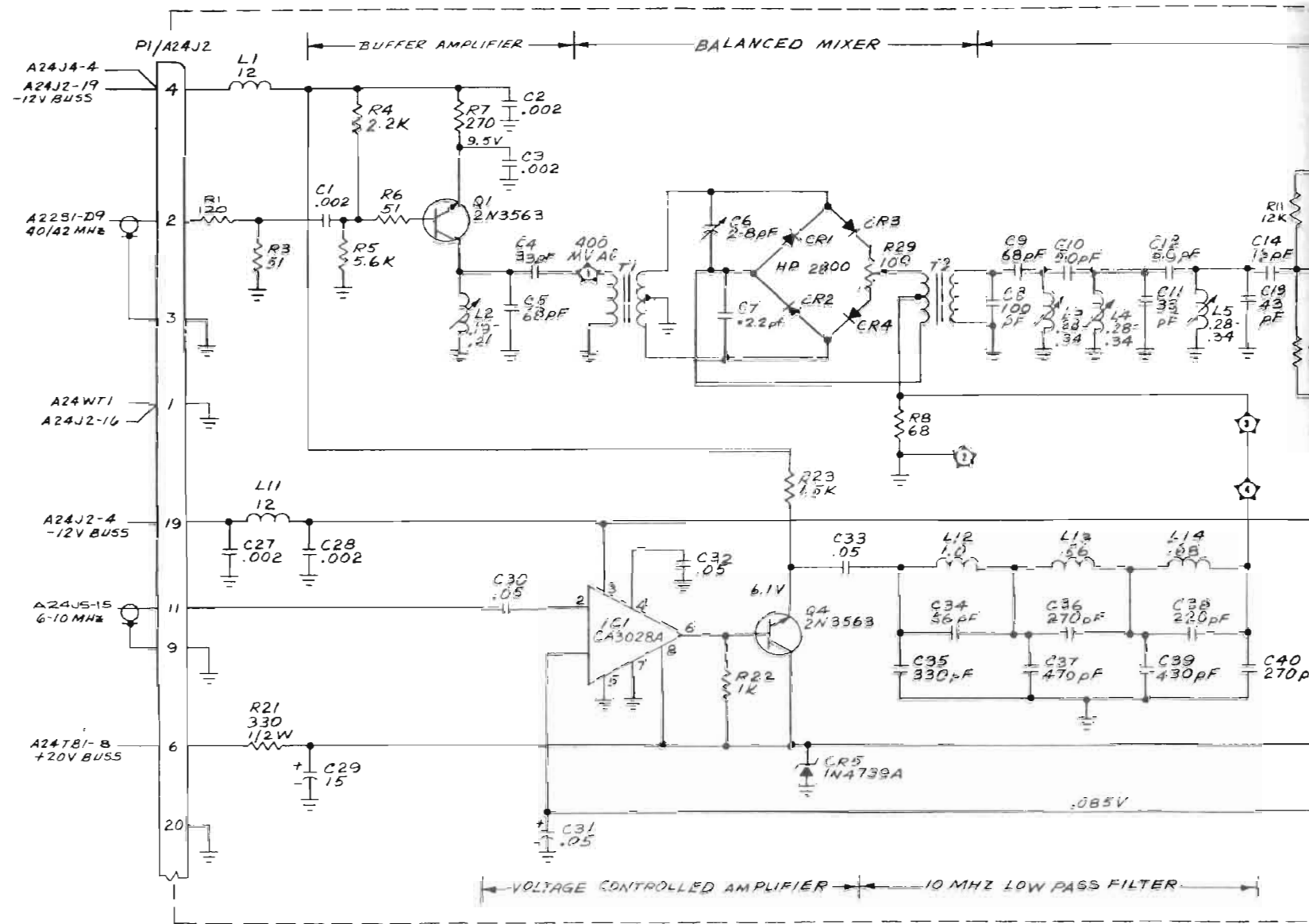

NOTE:
 1. RESISTORS - 1/4W, 1% VALUES IN OHMS UNLESS OTHERWISE NOTED.
 2. CAPACITORS - VALUES IN μ F UNLESS OTHERWISE NOTED.
 3. INDUCTORS - VALUES IN μ H UNLESS OTHERWISE NOTED.
 4. *FACTORY SELECT. TYPICAL VALUE SHOWN.
 5. ALL VOLTAGES ARE DC UNLESS OTHERWISE NOTED.

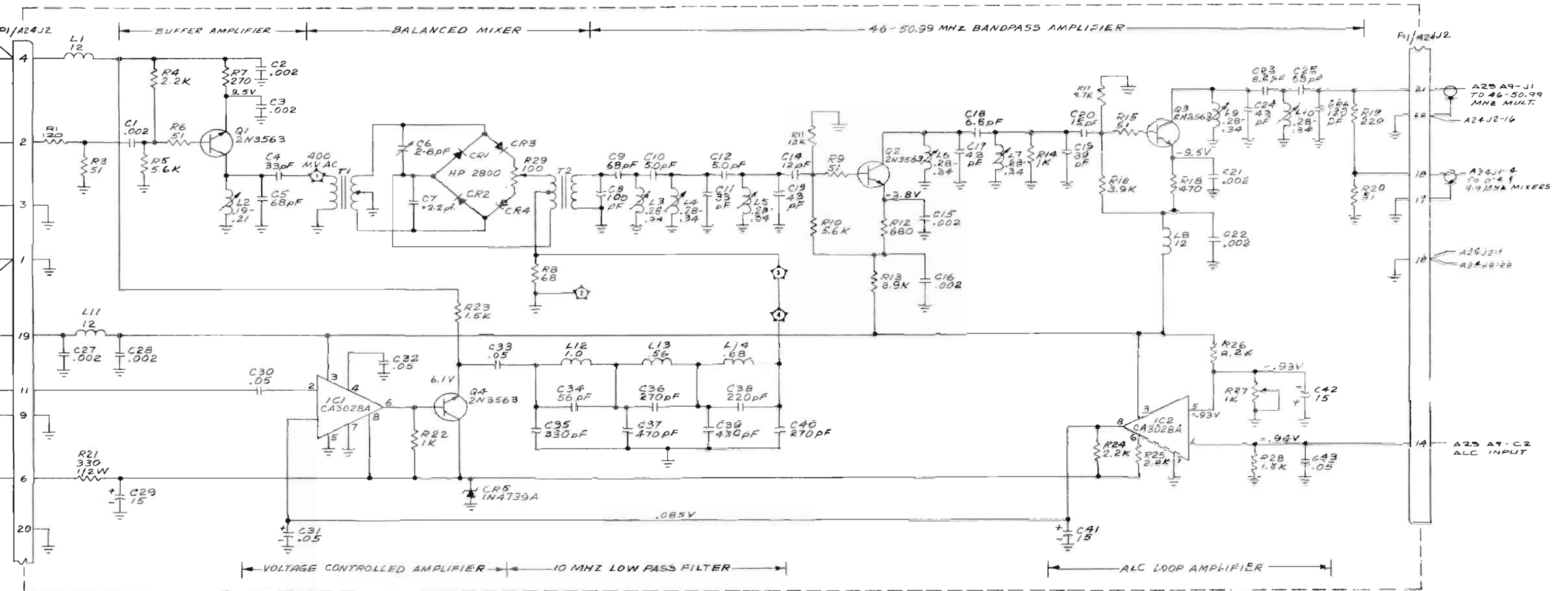

- NOTE:
1. RESISTORS - 1/4W, 5% VALUES IN OHMS UNLESS OTHERWISE NOTED.
 2. CAPACITORS - VALUES IN μ F UNLESS OTHERWISE NOTED.
 3. INDUCTORS - VALUES IN μ H UNLESS OTHERWISE NOTED.
 4. *FACTORY SELECT, TYPICAL VALUE SHOWN.
 5. ALL VOLTAGES ARE DC UNLESS OTHERWISE NOTED.

Figure 6-7. 46.00-50.99 MHz Balanced Mixer. A8
6-35/6-36

46.00-50.99 MHZ X10 MULTIPLIER.A9

CKT. REF.	DESCRIPTION	CE STOCK NO.	MFR.	MFR. NO.
A9	Container Assy, 46.00-50.99 MHz X10 Multiplier	7046-0018	Cushman	
	46.00-50.99 MHz x 10 Multiplier P. C. Board Assy	7001-0209	Cushman	
	P. C. Board	1780-0066	Cushman	
CAPACITORS				
C1	Feed Thru, 1000pF, $\pm 20\%$, 500V	1005-0008	Erie	357-001-X5U0-102M
C2	Feed Thru, 1000pF, $\pm 20\%$, 500V	1005-0008	Erie	357-001-X5U0-102M
C3	Feed Thru, 1000pF, $\pm 20\%$, 500V	1005-0008	Erie	357-001-X5U0-102M
C4	Cer, .05 μ F, +80-20%, 25V	1005-0014	Erie	5855-505-Y5U0-503Z
C5	Cer, .002 μ F, $\pm 20\%$, 500V	1005-0003	Erie	831-596-Z5U-202M
C6	Cer, .002 μ F, $\pm 20\%$, 500V	1005-0003	Erie	831-596-Z5U-202M
C7	Cer, .002 μ F, $\pm 20\%$, 500V	1005-0003	Erie	831-596-Z5U-202M
C8	Cer, .002 μ F, $\pm 20\%$, 500V	1005-0003	Erie	831-596-Z5U-202M
C9	Cer, .002 μ F, $\pm 20\%$, 500V	1005-0003	Erie	831-596-Z5U-202M
C10	Mica, 24pF, $\pm 5\%$, 500V	1002-0051	Elmenco	DM15-C-240J
C11	Mica, 10pF, $\pm 5\%$, 500V	1002-0016	Elmenco	DM15-C-100J
C12	Cer, .002 μ F, $\pm 20\%$, 500V	1005-0003	Erie	831-596-Z5U-202M
C13	Cer, .002 μ F, $\pm 20\%$, 500V	1005-0003	Erie	831-596-Z5U-202M
C14	Cer, .002 μ F, $\pm 20\%$, 500V	1005-0003	Erie	831-596-Z5U-202M
C15	Cer, .002 μ F, $\pm 20\%$, 500V	1005-0003	Erie	831-596-Z5U-202M
C16	Mica, 24pF, $\pm 5\%$, 500V	1002-0051	Elmenco	DM15-C-240J
C17	Mica, 22pF, $\pm 5\%$, 500V	1002-0023	Elmenco	DM15-C-220J
C18	Cer, .1 μ F, $\pm 20\%$, 50V	1005-0097	Erie	8121-050-651-104M
C19	Cer, .002 μ F, $\pm 20\%$, 500V	1005-0003	Erie	831-596-Z5U-202M
C20	Cer, .002 μ F, $\pm 20\%$, 500V	1005-0003	Erie	831-596-Z5U-202M
C21	Mica, 12pF, $\pm 5\%$, 500V	1002-0017	Elmenco	DM15-C-120J
C22	Mica, 560pF, $\pm 5\%$, 300V	1002-0037	Elmenco	DM15-F-561J
C23	Cer, .002 μ F, $\pm 20\%$, 500V	1005-0003	Erie	831-596-Z5U-202M
C24	Cer, .002 μ F, $\pm 20\%$, 500V	1005-0003	Erie	831-596-Z5U-202M
C25	Cer, .05 μ F, +80-20%, 25V	1005-0014	Erie	5855-505-Y5U0-503Z
C26	Cer, .05 μ F, +80-20%, 25V	1005-0014	Erie	5855-505-Y5U0-503Z
C27	Cer, 4.7pF, .25pF, 500V	1005-0015	Erie	301-000-C0H0-479C
C28	Cer, .1 μ F, $\pm 20\%$, 50V	1005-0097	Erie	8121-050-651-104M
COILS				
L1	RF Choke, 4.7 μ H, $\pm 10\%$	1585-0021	Delevan	1537-28
L2	RF Choke, 4.7 μ H, $\pm 10\%$	1585-0021	Delevan	1537-28
L3	RF Choke, 4.7 μ H, $\pm 10\%$	1585-0021	Delevan	1537-28
L4	#24 Wire, 2 1/2 turns (blk)	7050-0022	Cushman	
L5	RF Choke, 4.7 μ H, $\pm 10\%$	1585-0021	Delevan	1537-28
L6	RF Choke, 4.7 μ H, $\pm 10\%$	1585-0021	Delevan	1537-28
L7	#24 Wire, 2 1/2 turns (blk)	7050-0022	Cushman	
L8	#24 Wire, 3 turns/Var.	7050-0005	Cushman	
CONNECTORS				
J1	Connector, Right Angle BNC	2536-0006	Startronics	UG-1098/U
J2	Connector, BNC	2536-0010	Kings	KC79-35
DIODES				
CR1	Ge, G633	1282-0005	ITT	G633
CR2	HP 2800	1283-0001	HPA	5082-2800
CR3	HP 2800	1283-0001	HPA	5082-2800
CR4	Step Recovery	1282-0008	HPA	5082-0180

46.00-50.99 MHz X10 MULTIPLIER (cont). A9

CKT. REF.	DESCRIPTION	CE STOCK NO.	MFR.	MFR. NO.
	FILTER			
Fil-1	460-522 MHz Coaxial	1040-0026	Cushman	
	RESISTORS			
R1	Comp, 120Ω, ±5%, 1/4W	1066-1215	Allen-Bradley	CB1215
R2	Comp, 1kΩ, ±5%, 1/4W	1066-1025	Allen-Bradley	CB1025
R3	Comp, 1.2kΩ, ±5%, 1/4W	1066-1225	Allen-Bradley	CB1225
R4	Comp, 2.7kΩ, ±5%, 1/4W	1066-2725	Allen-Bradley	CB2725
R5	Comp, 1kΩ, ±5%, 1/4W	1066-1025	Allen-Bradley	CB1025
R6	Comp, 1.2kΩ, ±5%, 1/4W	1066-1225	Allen-Bradley	CB1225
R7	Comp, 2.7kΩ, ±5%, 1/4W	1066-2725	Allen-Bradley	CB2725
R8	Comp, 220Ω, ±5%, 1/2W	1067-2215	Allen-Bradley	EB2215
R9	Comp, 24Ω, ±5%, 1/4W	1066-2405	Allen-Bradley	CB2405
R10	Not Used			
R11	Comp, 1kΩ, ±5%, 1/4W	1066-1025	Allen-Bradley	CB1025
R12	Not Used			
R13	Comp, 180Ω, ±5%, 1/2W	1067-1815	Allen-Bradley	EB1815
R14	Comp, 3.3kΩ, ±5%, 1/4W	1066-3325	Allen-Bradley	CB3325
R15	Comp, 1.5kΩ, ±5%, 1/4W	1066-1525	Allen-Bradley	CB1525
	TRANSFORMER			
T1	Toroid, #28 Wire, 17 turns Bifilar	1579-0013	Cushman	
	TRANSISTORS			
Q1	Si, NPN, 2N3563	1272-0022	Fairchild	2N3563
Q2	Si, NPN, 2N3563	1272-0022	Fairchild	2N3563
Q3	Si, NPN, 2N3866	1271-0005	RCA	2N3866

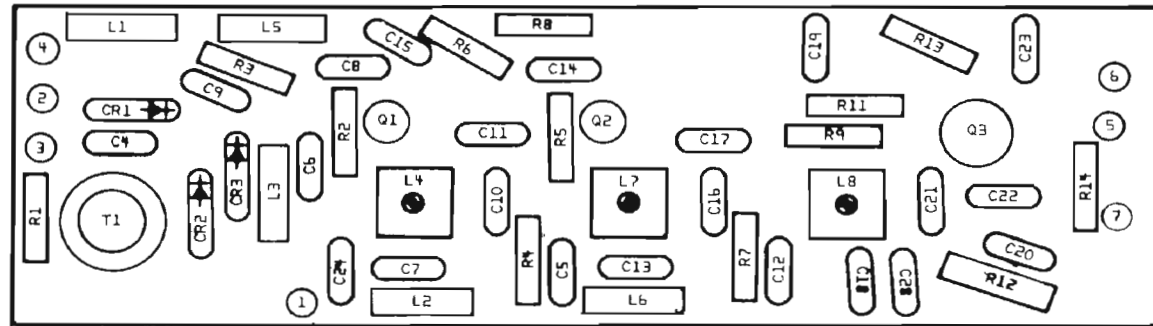

R10 & R12 NOT USED

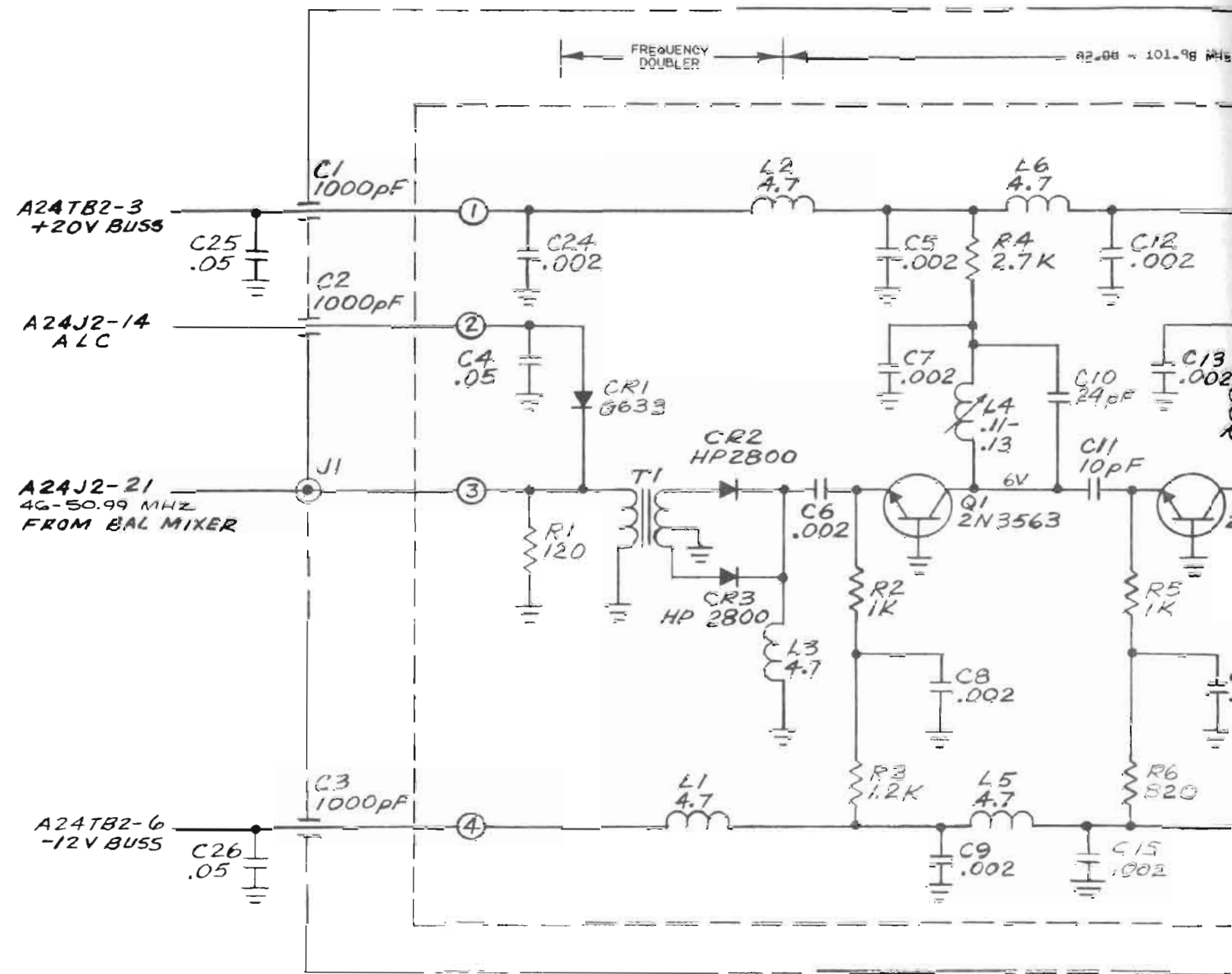

NOTE:

1. RESISTORS - 1/4W, 5% VALUES IN OHMS UNLESS OTHERWISE NOTED.
2. CAPACITORS - VALUES IN μ F UNLESS OTHERWISE NOTED.
3. INDUCTORS - VALUES IN μ H UNLESS OTHERWISE NOTED.
4. *FACTORY SELECT. TYPICAL VALUE SHOWN.
5. ALL VOLTAGES ARE DC UNLESS OTHERWISE NOTED.

R10 & R12 NOT USED

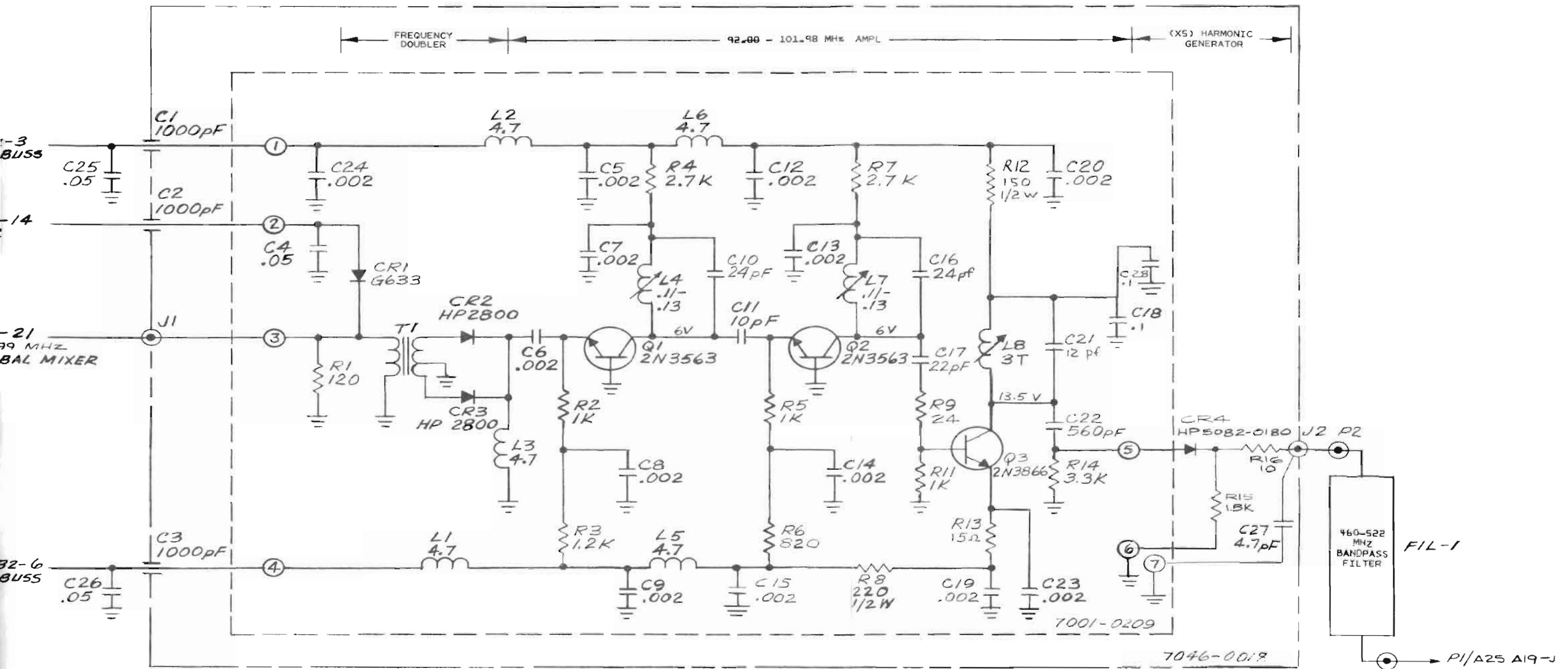

- NOTE:
1. RESISTORS - 1/4W, 5% VALUES IN OHMS UNLESS OTHERWISE NOTED.
 2. CAPACITORS - VALUES IN μ F UNLESS OTHERWISE NOTED.
 3. INDUCTORS - VALUES IN μ H UNLESS OTHERWISE NOTED.
 4. *FACTORY SELECT. TYPICAL VALUE SHOWN.
 5. ALL VOLTAGES ARE DC UNLESS OTHERWISE NOTED.

R10 & R12 NOT USED

Figure 6-8. 46.00-50.99 MHz X10 Multiplier. A9
6-39/6-40

43 MHz X10 MULTIPLIER. A10

CKT. REF.	DESCRIPTION	CE STOCK NO.	MFR.	MFR. NO.
A10	Container Assy, 43MHz X10 Multiplier	7046-0017	Cushman	
	43 MHz x 10 Multiplier			
	P.C. Board Assy	7001-0210	Cushman	
	P.C. Board	1780-0067	Cushman	
CAPACITORS				
C1	Cer, .01 μ F, +80% -20%, 25V	1005-0013	Erie	5835-512-Y5U-103Z
C2	Cer, .002 μ F, \pm 20%, 500V	1005-0003	Erie	831-596-Z5U-202M
C3	Cer, .01 μ F, +80% -20%, 25V	1005-0013	Erie	5835-512-Y5U-103Z
C4	Cer, .002 μ F, \pm 20%, 500V	1005-0003	Erie	831-596-Z5U-202M
C5	Cer, .002 μ F, \pm 20%, 500V	1005-0003	Erie	831-596-Z5U-202M
C6	Cer, .002 μ F, \pm 20%, 500V	1005-0003	Erie	831-596-Z5U-202M
C7	Cer, .002 μ F, \pm 20%, 500V	1005-0003	Erie	831-596-Z5U-202M
C8	Cer, .002 μ F, \pm 20%, 500V	1005-0003	Erie	831-596-Z5U-202M
C9	Mica, 75pF, \pm 5%, 500V	1002-0025	Elmenco	DM15-E-750J
C10	Mica, 12pF, \pm 5%, 500V	1002-0017	Elmenco	DM15-C-120J
C11	Cer, .002 μ F, \pm 20%, 500V	1005-0003	Erie	831-596-Z5U-202M
C12	Mica, 30pF, \pm 5%, 500V	1002-0043	Elmenco	DM15-E-300J
C13	Cer, .002 μ F, \pm 20%, 500V	1005-0003	Erie	831-596-Z5U-202M
C14	Mica, 10pF, \pm 5%, 500V	1002-0016	Elmenco	DM15-C-100J
C15	Cer, .002 μ F, \pm 20%, 500V	1005-0003	Erie	831-596-Z5U-202M
C16	Cer, .002 μ F, \pm 20%, 500V	1005-0003	Erie	831-596-Z5U-202M
C17	Mica, 10pF, \pm 5%, 500V	1002-0016	Elmenco	DM15-C-100J
C18	Mica, 30pF, \pm 5%, 500V	1002-0043	Elmenco	DM15-E-300J
C19	Cer, .002 μ F, \pm 20%, 500V	1005-0003	Erie	831-596-Z5U-202M
C20	Feed Thru, 1000pF, \pm 20%, 500V	1005-0008	Erie	857-001-X5U0-503Z
C21	Feed Thru, 1000pF, \pm 20%, 500V	1005-0008	Erie	857-001-X5U0-503Z
C22	Var, 5.5-18pF	1001-0008	Erie	538-002A-5.5-18
COILS				
L1	RF Choke, 12 μ H, \pm 10%	1585-0011	Delevan	1537-38
L2	RF Choke, 12 μ H, \pm 10%	1585-0011	Delevan	1537-38
L3	Var. Inductor, 0.19-0.21 μ H	1596-0010	Cushman	
L4	RF Choke, 5.6 μ H, \pm 10%	1585-0028	Delevan	1537-30
L5	RF Choke, 22 μ H, \pm 10%	1585-0012	Delevan	1537-44
L6	RF Choke, 5.6 μ H, \pm 10%	1585-0028	Delevan	1537-30
L7	Var, #22 Wire, 3 turns, (blk)	7050-0005	Cushman	
L8	Var, #22 Wire, 3 turns, (blk)	7050-0005	Cushman	
L9	RF Choke, 12 μ H, \pm 10%	1585-0011	Delevan	1537-38
L10	RF Choke, 12 μ H, \pm 10%	1585-0011	Delevan	1537-38
L11	RF Choke, .22 μ H, \pm 20%	1585-0039	Delevan	1537-02
CONNECTORS				
J1	Connector, Right Angle BNC	2536-0006	Startronics	UG-1098/U
J2	Connector, BNC	2536-0010	Kings	KC79-35
DIODES				
CR1	Si, 1N3064	1281-0013	Sylvania	1N3064
CR2	Diode, A4X196	1282-0009	Aertech	A4X196
FILTER				
Fil-1	Filter, 430 MHz, Coaxial	1040-0009	Cushman	
RESISTORS				
R1	Comp, 68 Ω , \pm 5%, 1/4W	1066-6805	Allen-Bradley	CB6805
R2	Comp, 2.2k Ω , \pm 5%, 1/4W	1066-2225	Allen-Bradley	CB2225
R3	Comp, 2.2k Ω , \pm 5%, 1/4W	1066-2225	Allen-Bradley	CB2225
R4	Comp, 2.2k Ω , \pm 5%, 1/4W	1066-2225	Allen-Bradley	CB2225
R5	Comp, 2.2k Ω , \pm 5%, 1/4W	1066-2225	Allen-Bradley	CB2225

43 MHz X10 MULTIPLIER (cont). A10

CKT. REF.	DESCRIPTION	CE STOCK NO.	MFR.	MFR. NO.
R6	Comp, 470Ω, ±5%, 1/4W	1066-4715	Allen-Bradley	CB4715
R7	Comp, 1kΩ, ±5%, 1/4W	1066-1025	Allen-Bradley	CB1025
R8	Comp, 1.2kΩ, ±5%, 1/4W	1066-1225	Allen-Bradley	CB1225
R9	Comp, 2.7kΩ, ±5%, 1/4W	1066-2725	Allen-Bradley	CB2725
R10	Comp, FSV, ±5%, 1/4W	1066-xxx	Allen-Bradley	CBxxxx
TRANSISTORS				
Q1	Si, NPN, 2N3563	1272-0022	Fairchild	2N3563
Q2	Si, NPN, 2N3563	1272-0022	Fairchild	2N3563
Q3	Si, NPN, 2N3866	1271-0005	RCA	2N3866

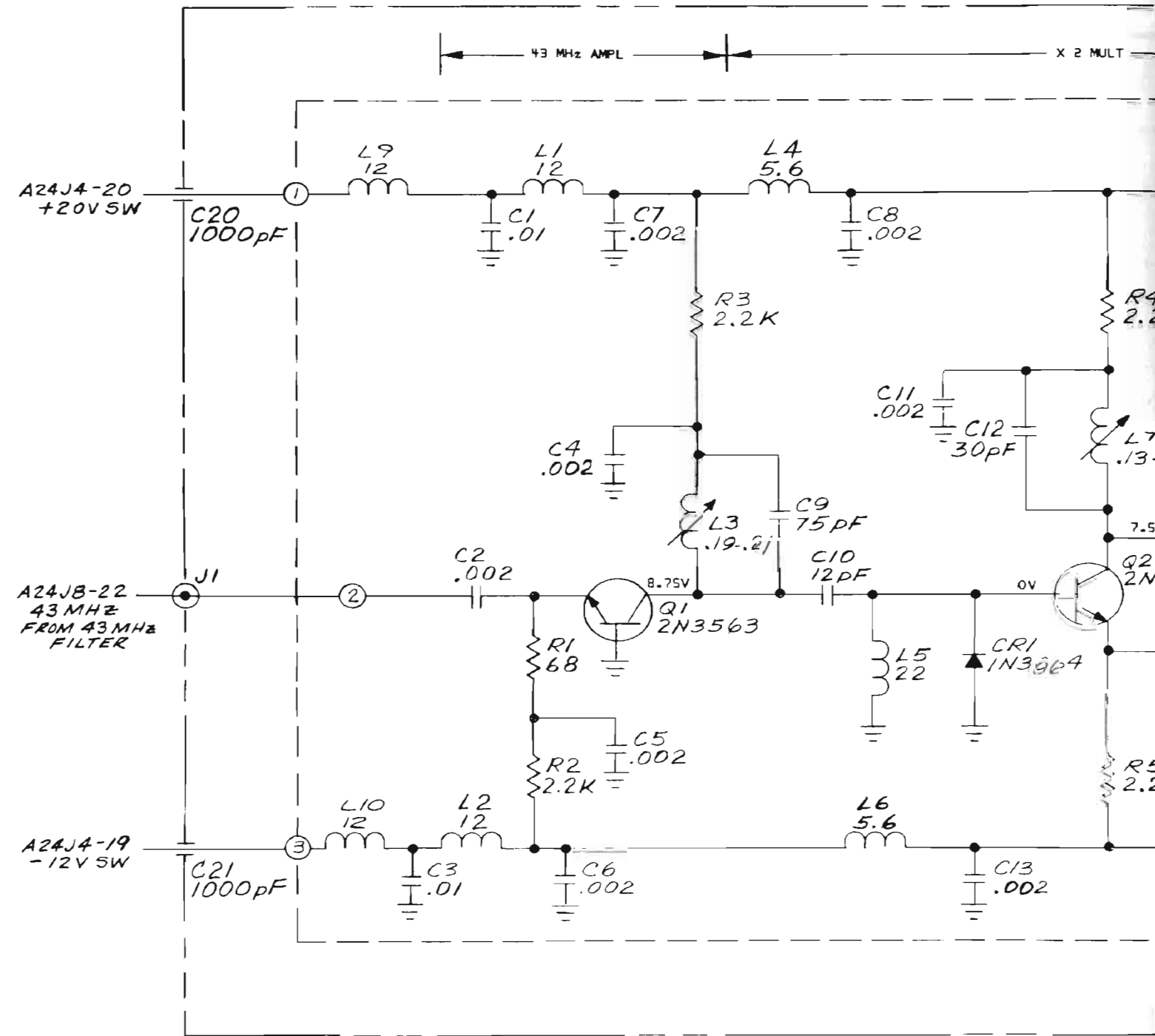
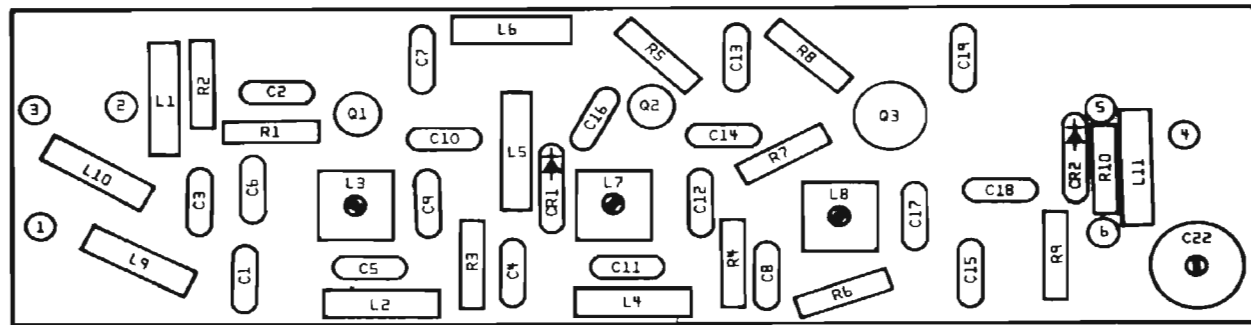

NOTE:

1. RESISTORS - 1/4W, 5% VALUES IN OHMS UNLESS OTHERWISE NOTED.
2. CAPACITORS - VALUES IN μ F UNLESS OTHERWISE NOTED.
3. INDUCTORS - VALUES IN μ H UNLESS OTHERWISE NOTED.
4. *FACTORY SELECT. TYPICAL VALUE SHOWN.
5. ALL VOLTAGES ARE DC UNLESS OTHERWISE NOTED.

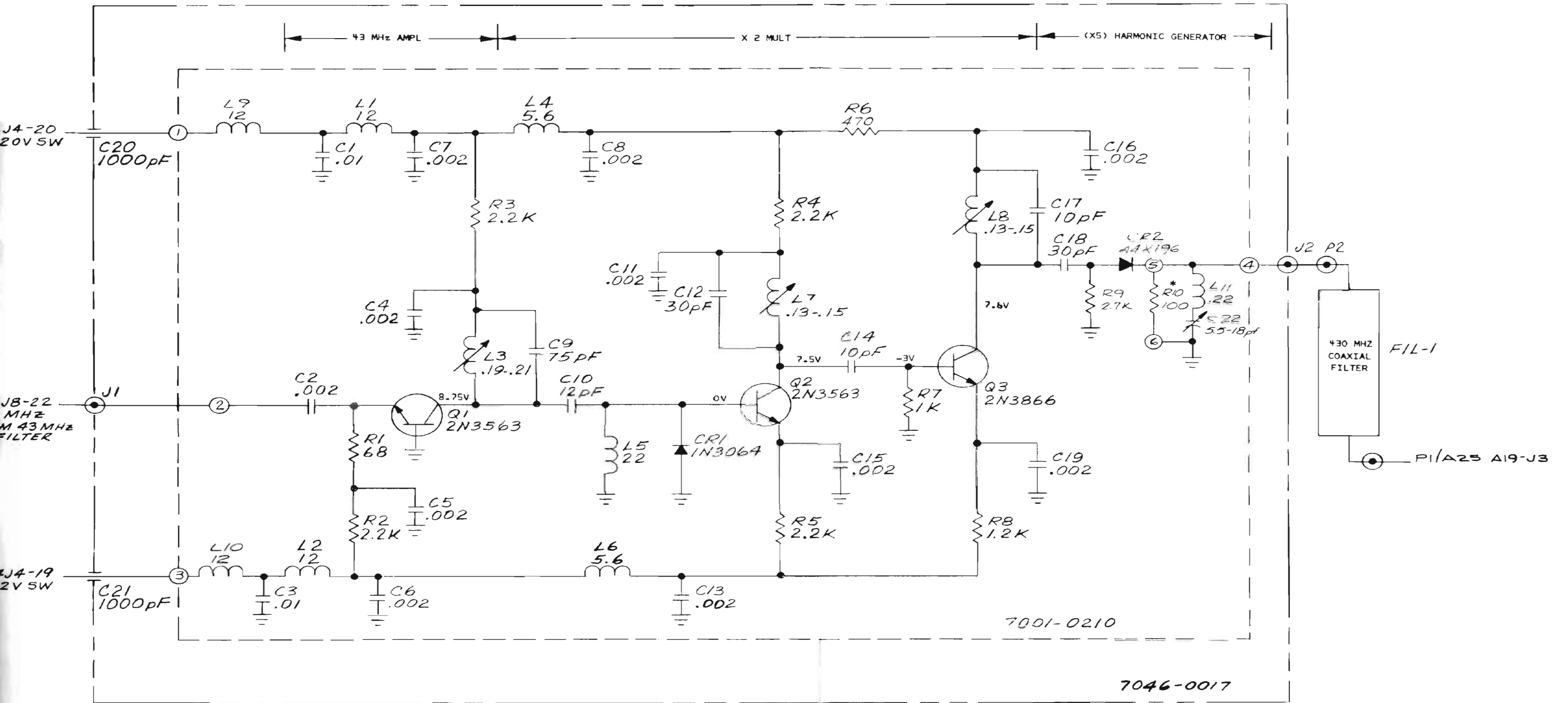

NOTE:

1. RESISTORS - 1/4W, 5% VALUES IN OHMS UNLESS OTHERWISE NOTED.
2. CAPACITORS - VALUES IN μF UNLESS OTHERWISE NOTED.
3. INDUCTORS - VALUES IN μH UNLESS OTHERWISE NOTED.
4. *FACTORY SELECT. TYPICAL VALUE SHOWN.
5. ALL VOLTAGES ARE DC UNLESS OTHERWISE NOTED.

Figure 6-9 43 MHz X10 Multiplier. A10
6-43/6-44

40 MHz, 43 MHz, AND 46 MHz FILTER. A11

CKT. REF.	DESCRIPTION	CE STOCK NO.	MFR.	MFR. NO.
A11	40 MHz, 43 MHz, and 46 MHz Filter - P. C. Board Assy	7001-0211	Cushman	
	P. C. Board	1780-0078	Cushman	
	CAPACITORS			
C1	Cer, .05 μ F, +80% -20%, 25V	1005-0014	Erie	5855-505-Y5U0-503Z
C2	Cer, .002 μ F, \pm 20%, 500V	1005-0003	Erie	831-596-Z5U-202M
C3	Mica, 270pF, \pm 5%, 500V	1002-0031	Elmenco	DM15-F-271J
C4	Cer, .002 μ F, \pm 20%, 500V	1005-0003	Erie	831-596-Z5U-202M
C5	Mica, 470pF, \pm 5%, 500V	1002-0035	Elmenco	DM15-F-471J
C6	Cer, .002 μ F, \pm 20%, 500V	1005-0003	Erie	831-596-Z5U-202M
C7	Cer, .002 μ F, \pm 20%, 500V	1005-0003	Erie	831-596-Z5U-202M
C8	Mica, 91pF, \pm 5%, 500V	1002-0027	Elmenco	DM15-F-910J
C9	Cer, .002 μ F, \pm 20%, 500V	1005-0003	Erie	831-596-Z5U-202M
C10	Cer, .002 μ F, \pm 20%, 500V	1005-0003	Erie	831-596-Z5U-202M
C11	Cer, 2.2pF, \pm .25pF, 500V	1005-0017	Erie	301-000-C0J0-229C
C12	Cer, .002 μ F, \pm 20%, 500V	1005-0003	Erie	831-596-Z5U-202M
C13	Mica, 33pF, \pm 5%, 500V	1002-0024	Elmenco	DM15-E-330J
C14	Var. Cer, 9-35pF, 35V	1001-0006	Erie	538-002-94D
C15	Cer, .002 μ F, \pm 20%, 500V	1005-0003	Erie	831-596-Z5U-202M
C16	Cer, .002 μ F, \pm 20%, 500V	1005-0003	Erie	831-596-Z5U-202M
C17	Cer, .002 μ F, \pm 20%, 500V	1005-0003	Erie	831-596-Z5U-202M
C18	Cer, .002 μ F, \pm 20%, 500V	1005-0003	Erie	831-596-Z5U-202M
C19	Cer, .002 μ F, \pm 20%, 500V	1005-0003	Erie	831-596-Z5U-202M
C20	Cer, .002 μ F, \pm 20%, 500V	1005-0003	Erie	831-596-Z5U-202M
C21	Mica, 82pF, \pm 5%, 500V	1002-0020	Elmenco	DM15-E-820J
C22	Cer, 3.3pF, \pm .25pF, 500V	1005-0011	Erie	301-000-C0J0-339C
C23	Cer, .002 μ F, \pm 20%, 500V	1005-0003	Erie	831-596-Z5U-202M
C24	Cer, .002 μ F, \pm 20%, 500V	1005-0003	Erie	831-596-Z5U-202M
C25	Mica, 82pF, \pm 5%, 500V	1002-0020	Elmenco	DM15-E-820J
C26	Cer, 3.3pF, \pm .25pF, 500V	1005-0011	Erie	301-000-C0J0-339C
C27	Cer, .002 μ F, \pm 20%, 500V	1005-0003	Erie	831-596-Z5U-202M
C28	Cer, .002 μ F, \pm 20%, 500V	1005-0003	Erie	831-596-Z5U-202M
C29	Mica, 82pF, \pm 5%, 500V	1002-0020	Elmenco	DM15-E-820J
C30	Cer, 3.3pF, \pm .25pF, 500V	1005-0011	Erie	301-000-C0J0-339C
C31	Cer, .002 μ F, \pm 20%, 500V	1005-0003	Erie	831-596-Z5U-202M
C32	Cer, .002 μ F, \pm 20%, 500V	1005-0003	Erie	831-596-Z5U-202M
C33	Mica, 82pF, \pm 5%, 500V	1002-0020	Elmenco	DM15-E-820J
C34	Cer, 3.3pF, \pm .25pF, 500V	1005-0011	Erie	301-000-C0J0-339C
C35	Cer, .002 μ F, \pm 20%, 500V	1005-0003	Erie	831-596-Z5U-202M
C36	Cer, .002 μ F, \pm 20%, 500V	1005-0003	Erie	831-596-Z5U-202M
C37	Cer, .002 μ F, \pm 20%, 500V	1005-0003	Erie	831-596-Z5U-202M
C38	Cer, .002 μ F, \pm 20%, 500V	1005-0003	Erie	831-596-Z5U-202M
C39	Cer, 3.3pF, \pm .25pF, 500V	1005-0011	Erie	301-000-C0J0-339C
C40	Mica, 91pF, \pm 5%, 500V	1002-0027	Elmenco	DM15-F-910J
C41	Cer, 3.3pF, \pm .25pF, 500V	1005-0011	Erie	301-000-C0J0-339C
C42	Cer, .002 μ F, \pm 20%, 500V	1005-0003	Erie	831-596-Z5U-202M
C43	Cer, .002 μ F, \pm 20%, 500V	1005-0003	Erie	831-596-Z5U-202M
C44	Cer, .002 μ F, \pm 20%, 500V	1005-0003	Erie	831-596-Z5U-202M
C45	Cer, .002 μ F, \pm 20%, 500V	1005-0003	Erie	831-596-Z5U-202M
C46	Cer, .002 μ F, \pm 20%, 500V	1005-0003	Erie	831-596-Z5U-202M
C47	Cer, .002 μ F, \pm 20%, 500V	1005-0003	Erie	831-596-Z5U-202M
C48	Mica, 68pF, \pm 5%, 500V	1002-0013	Elmenco	DM15-E-680J
C49	Cer, 5.0pF, \pm .25pF, 500V	1005-0112	Erie	301-000-C0HO-509C
C50	Cer, .002 μ F, \pm 20%, 500V	1005-0003	Erie	831-596-Z5U-202M

40 MHz, 43 MHz, AND 46 MHz FILTER (cont). A11

CKT. REF.	DESCRIPTION	CE STOCK NO.	MFR.	MFR. NO.
C51	Cer, .002 μ F, \pm 20%, 500V	1005-0003	Erie	831-596-Z5U-202M
C52	Cer, .002 μ F, \pm 20%, 500V	1005-0003	Erie	831-596-Z5U-202M
C53	Mica, 68pF, \pm 5%, 500V	1002-0013	Elmenco	DM15-E-680
C54	Cer, 4.7pF, \pm .25pF, 500V	1005-0015	Erie	301-C0H-479C
C55	Cer, .002 μ F, \pm 20%, 500V	1005-0003	Erie	831-596-Z5U-202M
C56	Cer, .002 μ F, \pm 20%, 500V	1005-0003	Erie	831-596-Z5U-202M
C57	Mica, 75pF, \pm 5%, 500V	1002-0025	Elmenco	DM15-E-750J
C58	Cer, 3.3pF, \pm .25pF, 500V	1005-0011	Erie	301-000-C0J0-339C
COILS				
L1	RF Choke, 12 μ H, \pm 10%	1585-0011	Delevan	1537-38
L2	RF Choke, 12 μ H, \pm 10%	1585-0011	Delevan	1537-38
L3	Var, 0.19-0.21 μ H	1596-0010	TRW	21023
L4	RF Choke, 12 μ H, \pm 10%	1585-0011	Delevan	1537-38
L5	RF Choke, 12 μ H, \pm 10%	1585-0011	Delevan	1537-38
L6	RF Choke, 12 μ H, \pm 10%	1585-0011	Delevan	1537-38
L7	Var, 0.19-0.21 μ H	1596-0010	TRW	21023
L8	Var, 0.19-0.21 μ H	1596-0010	TRW	21023
L9	Var, 0.19-0.21 μ H	1596-0010	TRW	21023
L10	Var, 0.19-0.21 μ H	1596-0010	TRW	21023
L11	RF Choke, 12 μ H, \pm 10%	1585-0011	Delevan	1537-38
L12	RF Choke, 12 μ H, \pm 10%	1585-0011	Delevan	1537-38
L13	Var, 0.19-0.21 μ H	1596-0010	TRW	21023
L14	RF Choke, 12 μ H, \pm 10%	1585-0011	Delevan	1537-38
L15	RF Choke, 12 μ H, \pm 10%	1585-0011	Delevan	1537-38
L16	Var, 0.19-0.21 μ H	1596-0010	TRW	21023
L17	Var, 0.19-0.21 μ H	1596-0010	TRW	21023
L18	Var, 0.19-0.21 μ H	1596-0010	TRW	21023
DIODES				
CR1	Si, 1N3064	1281-0013	Sylvania	1N3064
CR2	Ge, G633	1282-0005	ITT	G633
CR3	Ge, G633	1282-0005	ITT	G633
CR4	Si, 1N3064	1281-0013	Sylvania	1N3064
CR5	Si, 1N3064	1281-0013	Sylvania	1N3064
RESISTORS				
R1	Comp, 1k Ω , \pm 5%, 1/4W	1066-1025	Allen-Bradley	CB1025
R2	Comp, 10k Ω , \pm 5%, 1/4W	1066-1035	Allen-Bradley	CB1035
R3	Comp, 10k Ω , \pm 5%, 1/4W	1066-1035	Allen-Bradley	CB1035
R4	Comp, 10k Ω , \pm 5%, 1/4W	1066-1035	Allen-Bradley	CB1035
R5	Comp, 10k Ω , \pm 5%, 1/4W	1066-1035	Allen-Bradley	CB1035
R6	Comp, 3.9k Ω , \pm 5%, 1/4W	1066-3925	Allen-Bradley	CB3925
R7	Comp, 1k Ω , \pm 5%, 1/4W	1066-1025	Allen-Bradley	CB1025
R8	Comp, 22k Ω , \pm 5%, 1/4W	1066-2235	Allen-Bradley	CB2235
R9	Comp, 3.9k Ω , \pm 5%, 1/4W	1066-3925	Allen-Bradley	CB3925
R10	Comp, 10k Ω , \pm 5%, 1/4W	1066-1035	Allen-Bradley	CB1035
R11	Comp, 10k Ω , \pm 5%, 1/4W	1066-1035	Allen-Bradley	CB1035
R12	Comp, 3.9k Ω , \pm 5%, 1/4W	1066-3925	Allen-Bradley	CB3925
R13	Comp, 10k Ω , \pm 5%, 1/4W	1066-1035	Allen-Bradley	CB1035
R14	Comp, 10k Ω , \pm 5%, 1/4W	1066-1035	Allen-Bradley	CB1035
R15	Comp, 3.9k Ω , \pm 5%, 1/4W	1066-3925	Allen-Bradley	CB3925
R16	Comp, 10k Ω , \pm 5%, 1/4W	1066-1035	Allen-Bradley	CB1035
R17	Comp, 10k Ω , \pm 5%, 1/4W	1066-1035	Allen-Bradley	CB1035
R18	Comp, 1k Ω , \pm 5%, 1/4W	1066-1025	Allen-Bradley	CB1025
R19	Comp, 10k Ω , \pm 5%, 1/4W	1066-1035	Allen-Bradley	CB1035
R20	Comp, 10k Ω , \pm 5%, 1/4W	1066-1035	Allen-Bradley	CB1035

40 MHz, 43 MHz, AND 46 MHz FILTER (cont). A11

CKT. REF.	DESCRIPTION	CE STOCK NO.	MFR.	MFR. NO.
R21	Comp, 1k Ω , $\pm 5\%$, 1/4W	1066-1025	Allen-Bradley	CB1025
R22	Comp, 22k Ω , $\pm 5\%$, 1/4W	1066-2235	Allen-Bradley	CB2235
R23	Comp, 3.9k Ω , $\pm 5\%$, 1/4W	1066-3925	Allen-Bradley	CB3925
R24	Comp, 10k Ω , $\pm 5\%$, 1/4W	1066-1035	Allen-Bradley	CB1035
R25	Comp, 10k Ω , $\pm 5\%$, 1/4W	1066-1035	Allen-Bradley	CB1035
R26	Comp, 3.9k Ω , $\pm 5\%$, 1/4W	1066-3925	Allen-Bradley	CB3925
R27	Comp, 10k Ω , $\pm 5\%$, 1/4W	1066-1035	Allen-Bradley	CB1035
R28	Comp, 10k Ω , $\pm 5\%$, 1/4W	1066-1035	Allen-Bradley	CB1035
R29	Comp, 1k Ω , $\pm 5\%$, 1/4W	1066-1025	Allen-Bradley	CB1025
TRANSFORMERS				
T1	Toroid, 9 turns #26, 4 turns #26	C1579-0007	Cushman	
TRANSISTORS				
Q1	Si, PNP, TIS 37	1271-0003	T. I.	TIS 37
Q2	Si, PNP, TIS 37	1271-0003	T. I.	TIS 37
Q3	Si, PNP, TIS 37	1271-0003	T. I.	TIS 37
Q4	Si, PNP, TIS 37	1271-0003	T. I.	TIS 37
Q5	Si, PNP, TIS 37	1271-0003	T. I.	TIS 37
Q6	Si, PNP, TIS 37	1271-0003	T. I.	TIS 37
Q7	Si, PNP, TIS 37	1271-0003	T. I.	TIS 37
Q8	Si, PNP, TIS 37	1271-0003	T. I.	TIS 37
Q9	Si, PNP, TIS 37	1271-0003	T. I.	TIS 37
Q10	Si, PNP, TIS 37	1271-0003	T. I.	TIS 37

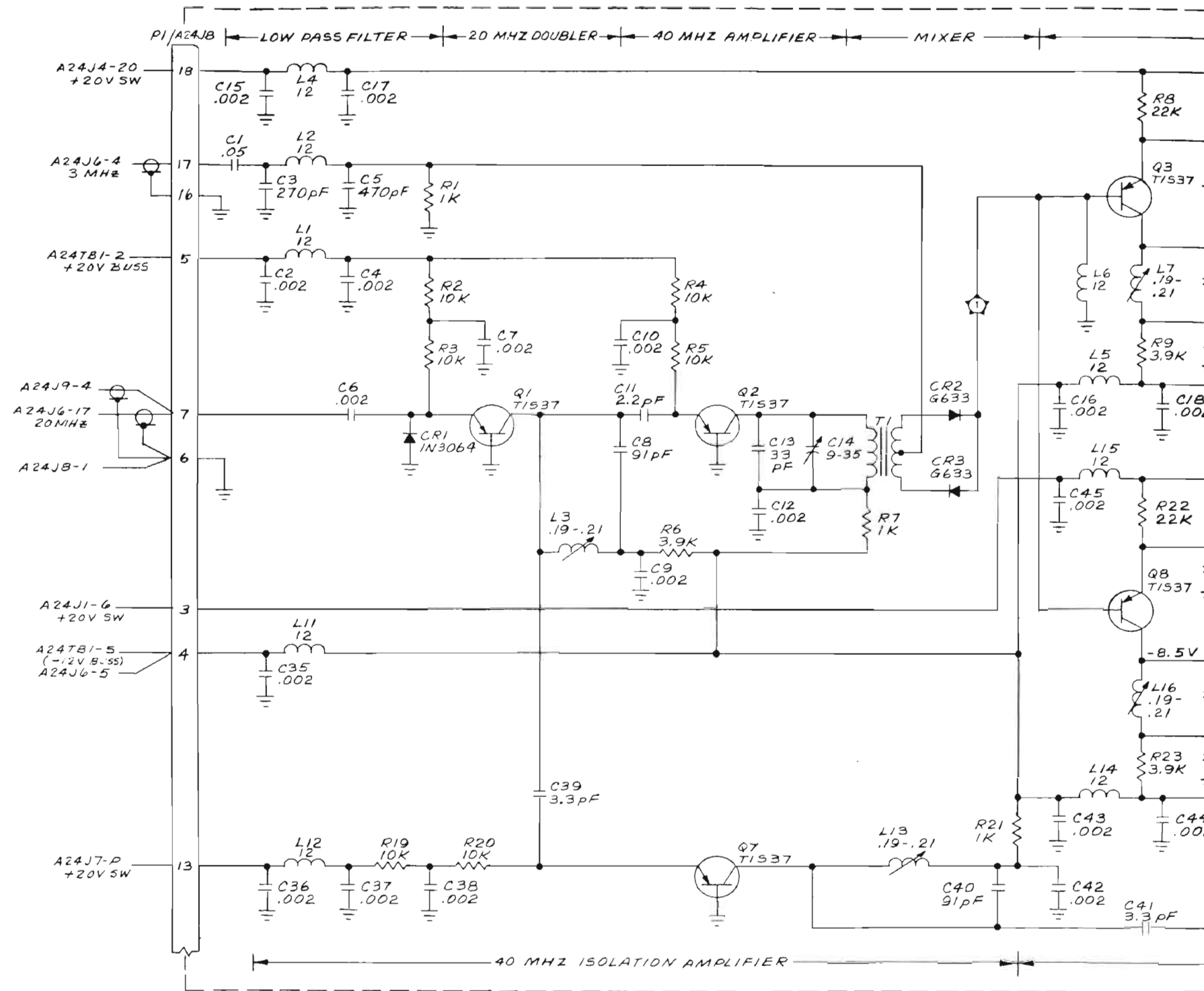
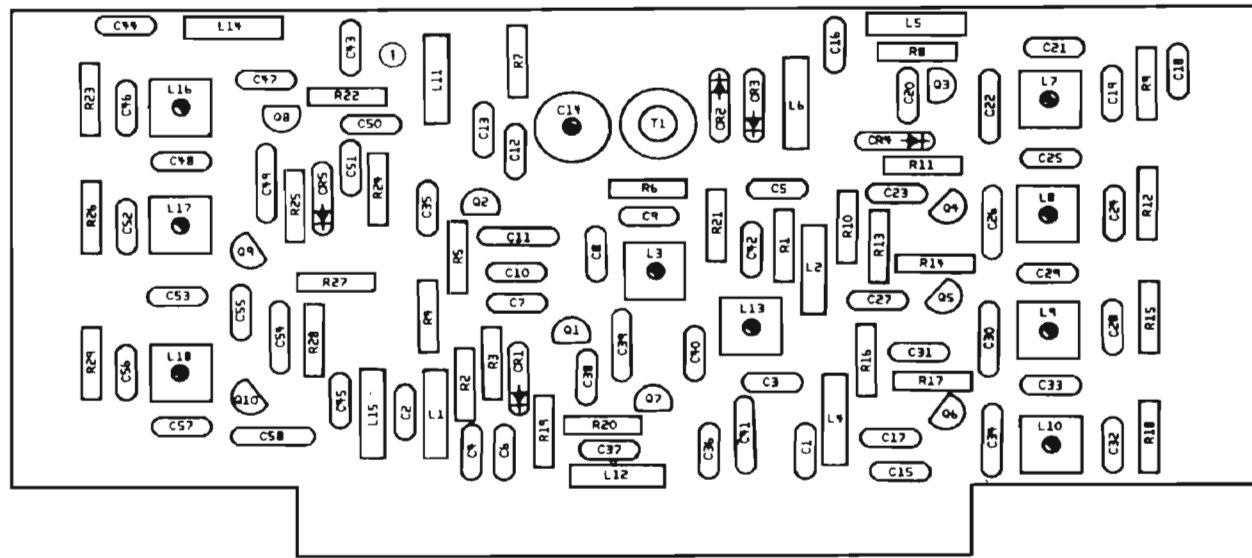

- NOTE:
1. RESISTORS - 1/4W, 5% VALUES IN OHMS UNLESS OTHERWISE NOTED.
 2. CAPACITORS - VALUES IN μ F UNLESS OTHERWISE NOTED.
 3. INDUCTORS - VALUES IN μ H UNLESS OTHERWISE NOTED.
 4. *FACTORY SELECT. TYPICAL VALUE SHOWN.
 5. ALL VOLTAGES ARE DC UNLESS OTHERWISE NOTED.

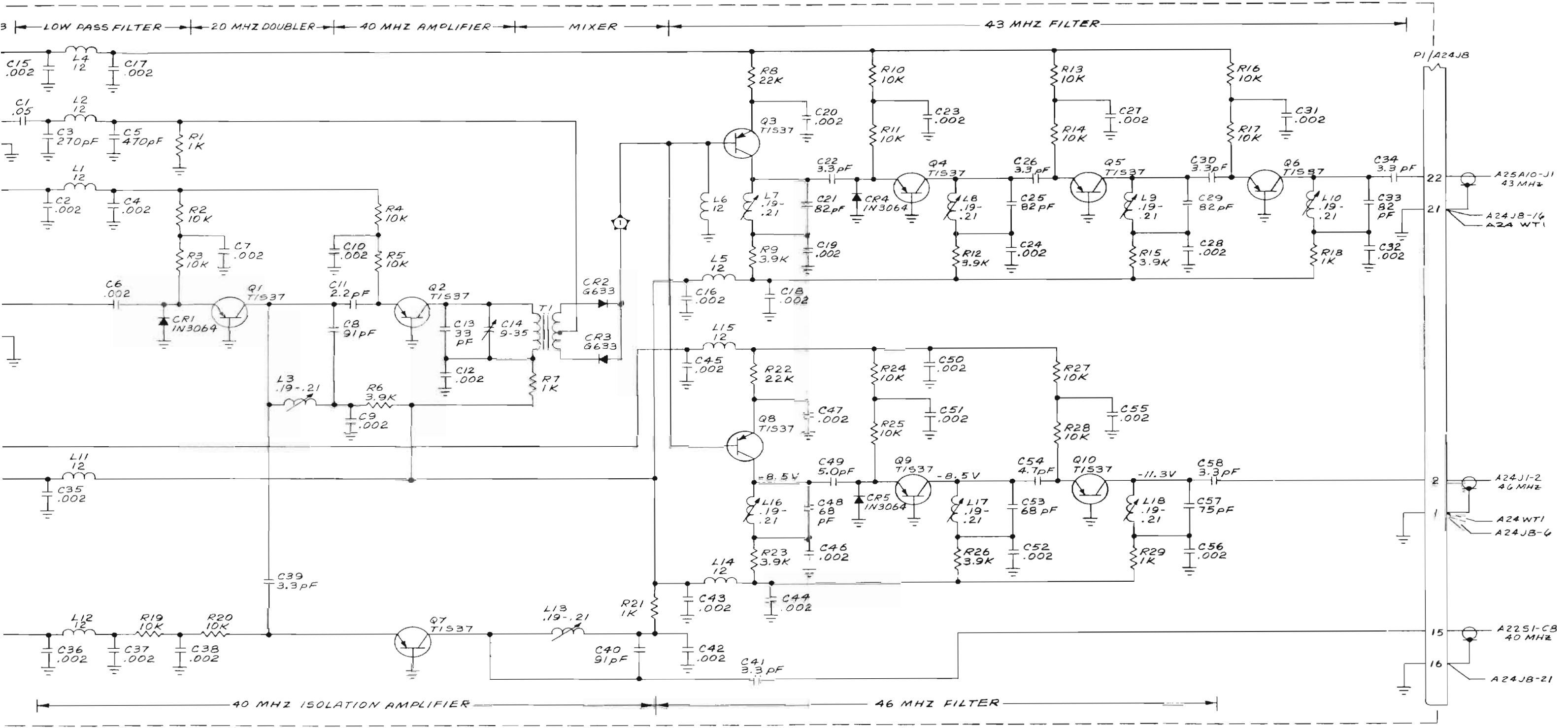

NOTE:
 1. RESISTORS - 1/4W, 5% VALUES IN OHMS UNLESS OTHERWISE NOTED.
 2. CAPACITORS - VALUES IN μ F UNLESS OTHERWISE NOTED.
 3. INDUCTORS - VALUES IN μ H UNLESS OTHERWISE NOTED.
 4. *FACTORY SELECT. TYPICAL VALUE SHOWN.
 5. ALL VOLTAGES ARE DC UNLESS OTHERWISE NOTED.

Figure 6-10. 40 MHz, 43 MHz, and 46 MHz Filter. A11

POWER SUPPLY REGULATOR. A12

CKT. REF.	DESCRIPTION	CE STOCK NO.	MFR.	MFR. NO.
A12	Power Supply Regulator			
	P. C. Board Assy	7001-0212	Cushman	
	P. C. Board	1780-0082	Cushman	
	CAPACITORS			
C1	Elect, 50 μ f, \pm 10%, 50V	1013-0007	Sprague	30D506G050DD5
C2	Cer, .002 μ F, \pm 20%, 500V	1005-0003	Erie	831-596-Z5U-202M
C3	Elect, 500 μ F, 25V	1014-0002	Pl. Elna	25T500
C4	Cer, .002 μ F, \pm 20%, 500V	1005-0003	Erie	831-596-Z5U-202M
C5	Elect, 250 μ F, +75% -10%, 16V	1013-0016	Sprague	30D257G016DF2
C6	Cer, .002 μ F, \pm 20%, 500V	1005-0003	Erie	831-596-Z5U-202M
C7	Elect, 500 μ F, 25V	1014-0002	Pl. Elna	25T500
C8	Tant, 10 μ F, +50 -20%, 35V	1011-0006	ITT	Tag 10/35-20
C9	Tant, 10 μ F, +50 -20%, 35V	1011-0006	ITT	Tag 10/35-20
	DIODES			
CR1	Not Used			
CR2	Zener, 6.2V	1281-0038	Transitron	1N827
CR3	Not Used			
CR4	Si, Zener, 4.3V, \pm 5%	1281-0025	I. R.	1N4731A
CR5	Si, Zener, 7.5V, \pm 5%, 1W	1281-0026	I. R.	1N4737A
CR6	Not Used			
CR7	Zener, 6.2V	1281-0038	Transitron	1N827
	INTEGRATED CIRCUITS			
IC1	Op. Amp. 2N72741N	2025-0022	T. I.	2N72741N
IC2	Op. Amp. 2N72741N	2025-0022	T. I.	2N72741N
	RESISTORS			
R1	Comp, 1k Ω , \pm 5%, 1/4W	1066-1025	Allen-Bradley	CB1025
R2	Comp, 470 Ω , \pm 5%, 1/4W	1066-4715	Allen-Bradley	CB4715
R3	Comp, 1k Ω , \pm 5%, 1/4W	1066-1025	Allen-Bradley	CB1025
R4	WW, 1 Ω , \pm 5%, 3W	1159-0001	Ohmite	4330
R5	Comp, 1.8k Ω , \pm 5%, 1/4W	1066-1825	Allen-Bradley	CB1825
R6	Metal Film, 887 Ω , \pm 1%, 1/8W	1075-0022	Dale	MFF 1/8 T1
R7	Pot, 500 Ω , \pm 10%, 3/4W	1215-0011	Helitrim	89WR
R8	Metal Film, 2.21k Ω , \pm 1%, 1/8W	1075-0010	Dale	MFF 1/8 T1
R9	Comp, 1k Ω , \pm 5%, 1/4W	1066-1025	Allen-Bradley	CB1025
R10	WW, .5 Ω , \pm 3%, 3W	1159-0002	Dale	RS-2B
R11	Comp, 6.8k Ω , \pm 5%, 1/4W	1066-6825	Allen-Bradley	CB6825
R12	Comp, 1.6k Ω , \pm 5%, 1/4W	1066-1625	Allen-Bradley	CB1625
R13	Comp, 10 Ω , \pm 5%, 1/4W	1066-1005	Allen-Bradley	CB1005
R14	Pot, 100 Ω , \pm 10%, 3/4W	1215-0010	Helitrim	89WR
R15	Comp, 270 Ω , \pm 5%, 1/4W	1066-2715	Allen-Bradley	CB2715
R16	Comp, 470 Ω , \pm 5%, 1/4W	1066-4715	Allen-Bradley	CB4715
R17	Comp, 1k Ω , \pm 5%, 1/4W	1066-1025	Allen-Bradley	CB1025
R18	WW, 1 Ω , \pm 5%, 3W	1159-0001	Ohmite	4330
R19	Comp, 820 Ω , \pm 5%, 1/4W	1066-8215	Allen-Bradley	CB8215
R20	Metal Film, 475 Ω , \pm 1%, 1/8W	1075-0023	Dale	MFF 1/8 T1
R21	Pot, 500 Ω , \pm 10%, 3/4W	1215-0011	Helitrim	89WR
R22	Metal Film, 475 Ω , \pm 1%, 1/8W	1075-0023	Dale	MFF 1/8 T1
R23	Comp, 820 Ω , \pm 5%, 1/4W	1066-8215	Allen-Bradley	CB8215
R24	Comp, 820 Ω , \pm 5%, 1/4W	1066-8215	Allen-Bradley	CB8215
R25	Comp, 820 Ω , \pm 5%, 1/4W	1066-8215	Allen-Bradley	CB8215

POWER SUPPLY REGULATOR (cont). A12

CKT. REF.	DESCRIPTION	CE STOCK NO.	MFR.	MFR. NO.
TRANSISTORS				
Q1	Si, NPN, 2N3053	1272-0011	RCA	2N3053
Q2	Si, NPN, 2N3567	1272-0014	Fairchild	2N3567
Q3	Si, NPN, 2N3053	1272-0011	RCA	2N3053
Q4	Si, NPN, 2N3567	1272-0014	Fairchild	2N3567
Q5	Si, NPN, 2N3567	1272-0014	Fairchild	2N3567
Q6	Si, NPN, 2N3053	1272-0011	RCA	2N3053
Q7	Si, NPN, 2N3567	1272-0014	Fairchild	2N3567

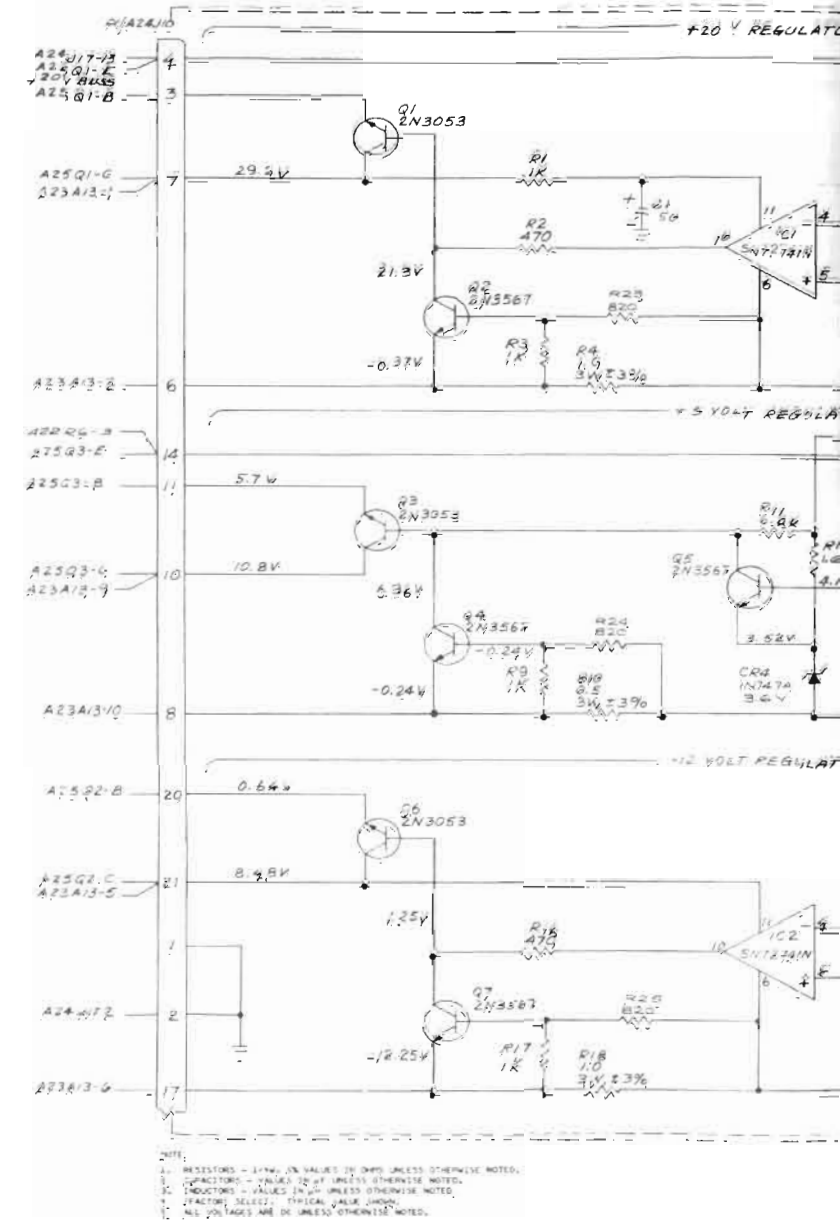
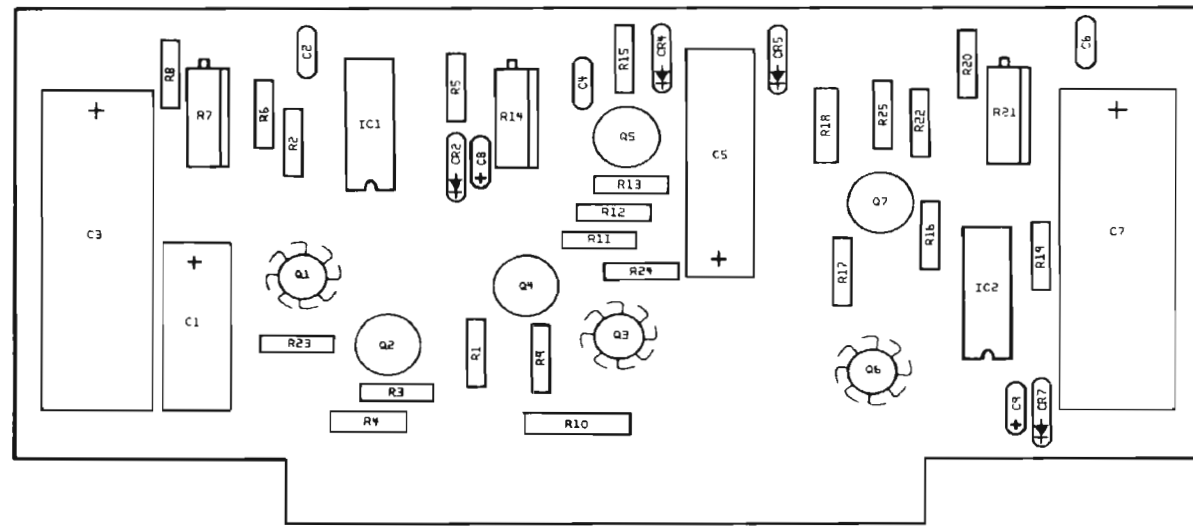

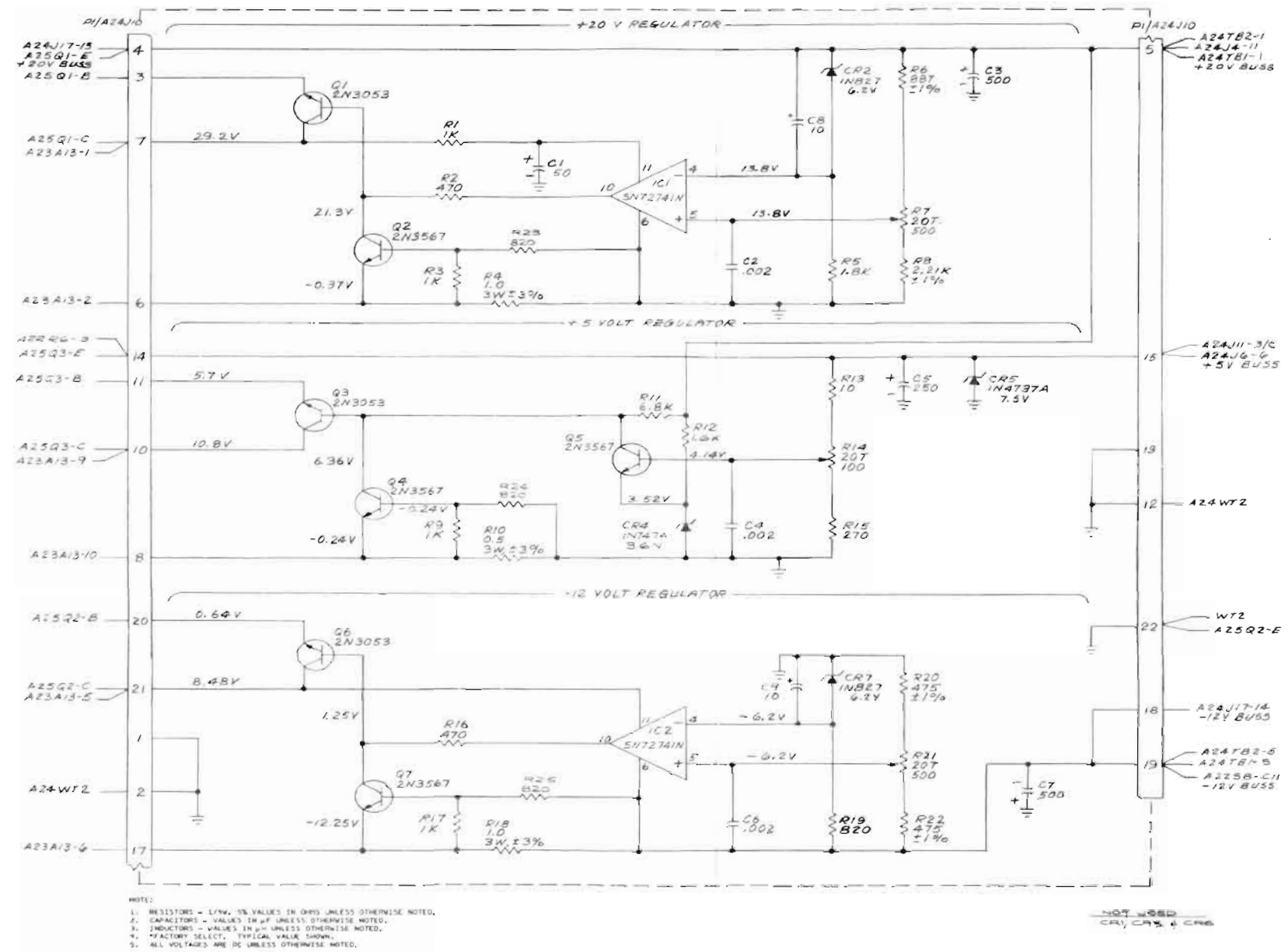
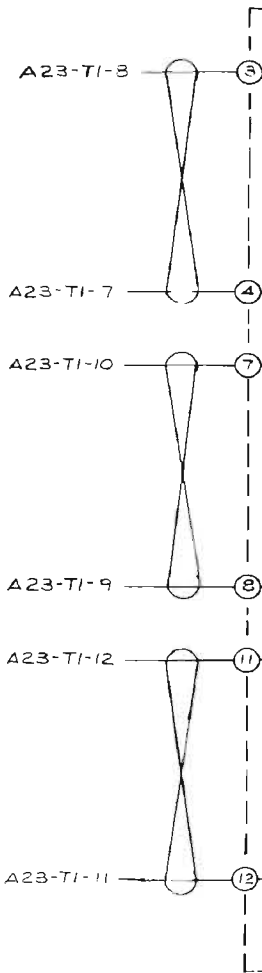
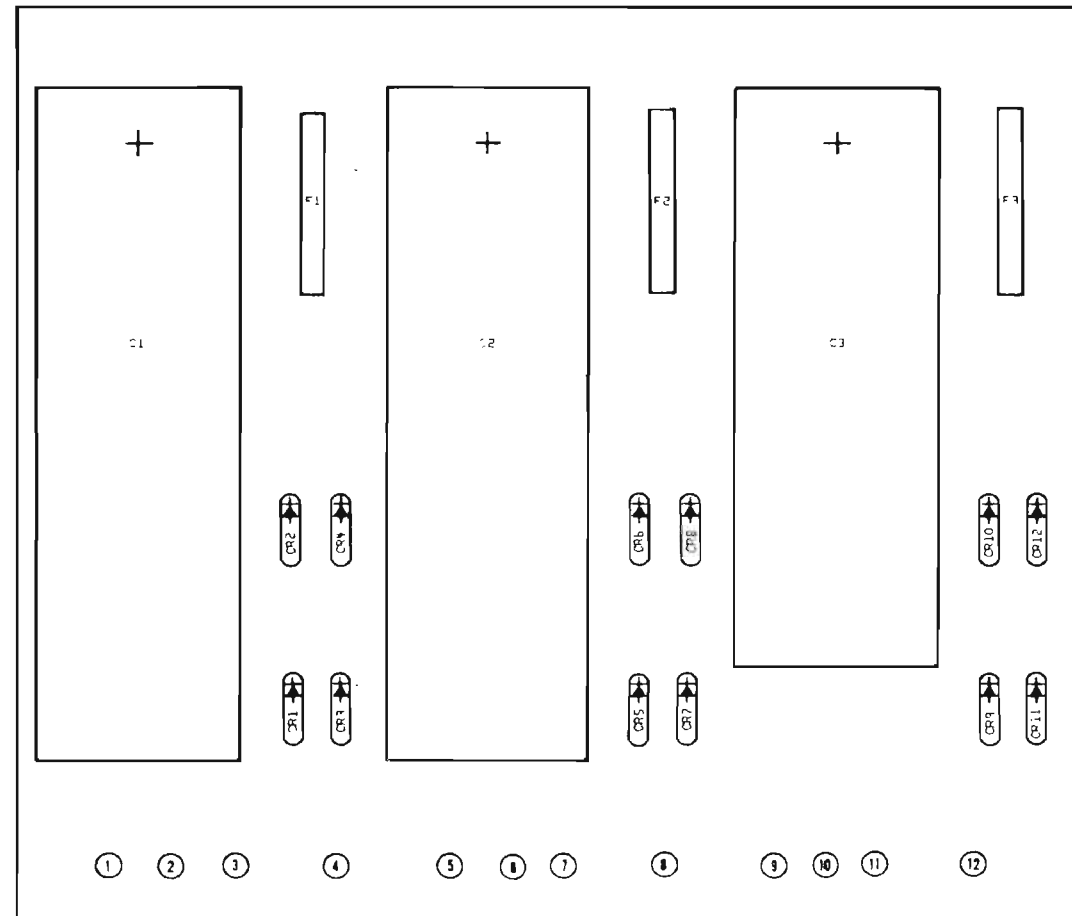

Figure 6-11. Power Supply Regulator. A12

POWER SUPPLY RECTIFIER, A13

CKT. REF.	DESCRIPTION	CE STOCK NO.	MFR.	MFR. NO.
A13	Power Supply Rectifier, P. C. Board Assy	7001-0213	Cushman	
	P. C. Board	1780-0084	Cushman	
	CAPACITORS			
C1	Elect, 2300 μ F, 50V	1014-0004	Sprague	39D-238G050JT5
C2	Elect, 2300 μ F, 50V	1014-0004	Sprague	39D-238G050JT5
C3	Elect, 4000 μ F, +75% -10%, 25V	1014-0005	Sprague	39D408G025JS5
	DIODES			
CR1	Si, 100V PIV, 1 amp	1281-0023	ITT	1N4002
CR2	Si, 100V PIV, 1 amp	1281-0023	ITT	1N4002
CR3	Si, 100V PIV, 1 amp	1281-0023	ITT	1N4002
CR4	Si, 100V PIV, 1 amp	1281-0023	ITT	1N4002
CR5	Si, 100V PIV, 1 amp	1281-0023	ITT	1N4002
CR6	Si, 100V PIV, 1 amp	1281-0023	ITT	1N4002
CR7	Si, 100V PIV, 1 amp	1281-0023	ITT	1N4002
CR8	Si, 100V PIV, 1 amp	1281-0023	ITT	1N4002
CR9	PIV, 2 amp Rectifier	1281-0024	Semtech	3SM2
CR10	PIV, 2 amp Rectifier	1281-0024	Semtech	3SM2
CR11	PIV, 2 amp Rectifier	1281-0024	Semtech	3SM2
CR12	PIV, 2 amp Rectifier	1281-0024	Semtech	3SM2
	FUSES			
F1	3AG, 1 1/2 amps, Slo-Blo	1955-0018	Bussman	AGC 1-1/2 S/B
F2	3AG, 1 1/2 amps, Slo-Blo	1955-0018	Bussman	AGC 1-1/2 S/B
F3	3AG, 2 1/2 amps, Slo-Blo	1955-0023	Bussman	AGC 2-1/2 S/B



NOT
1.
2.
3.
4.
5.

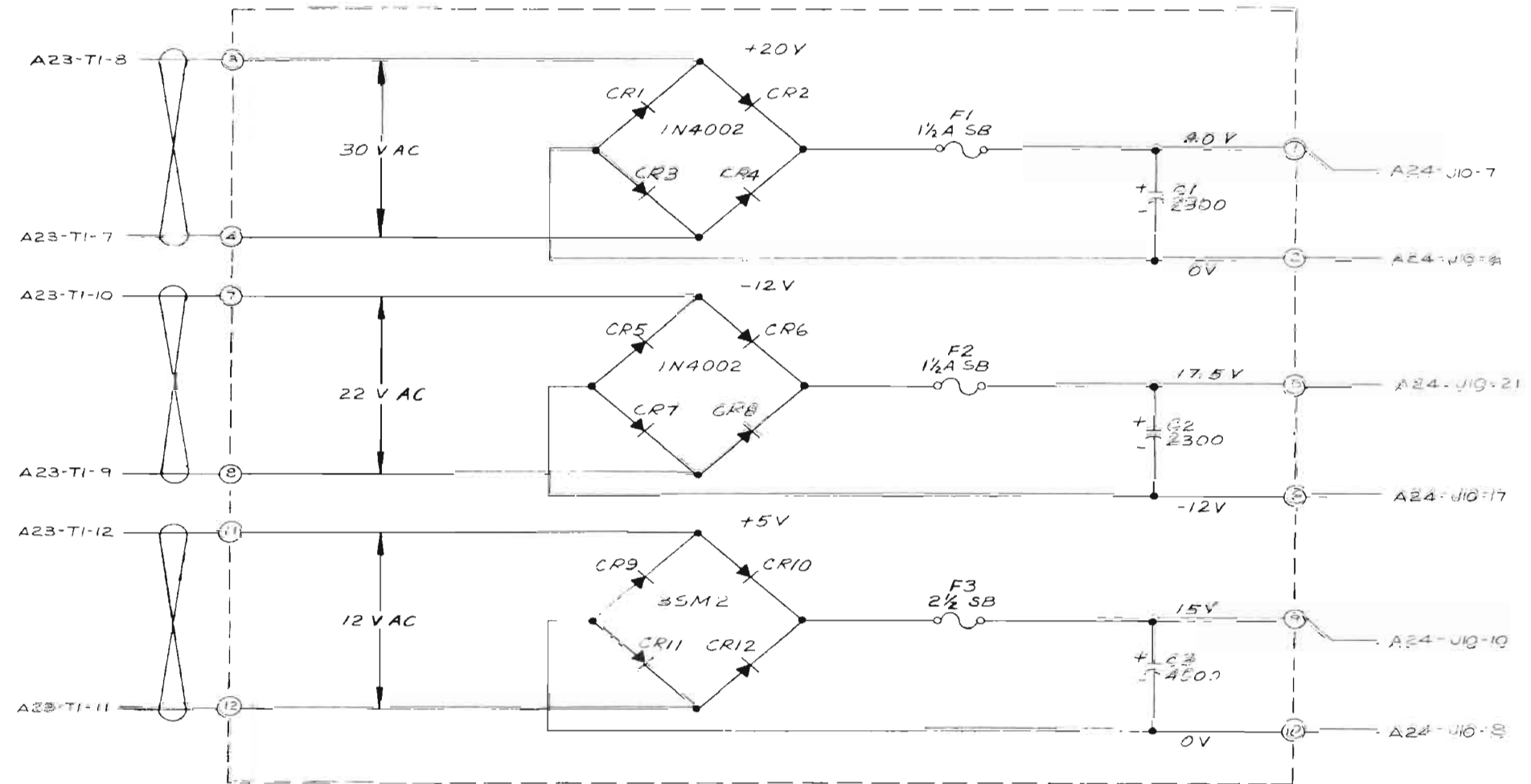
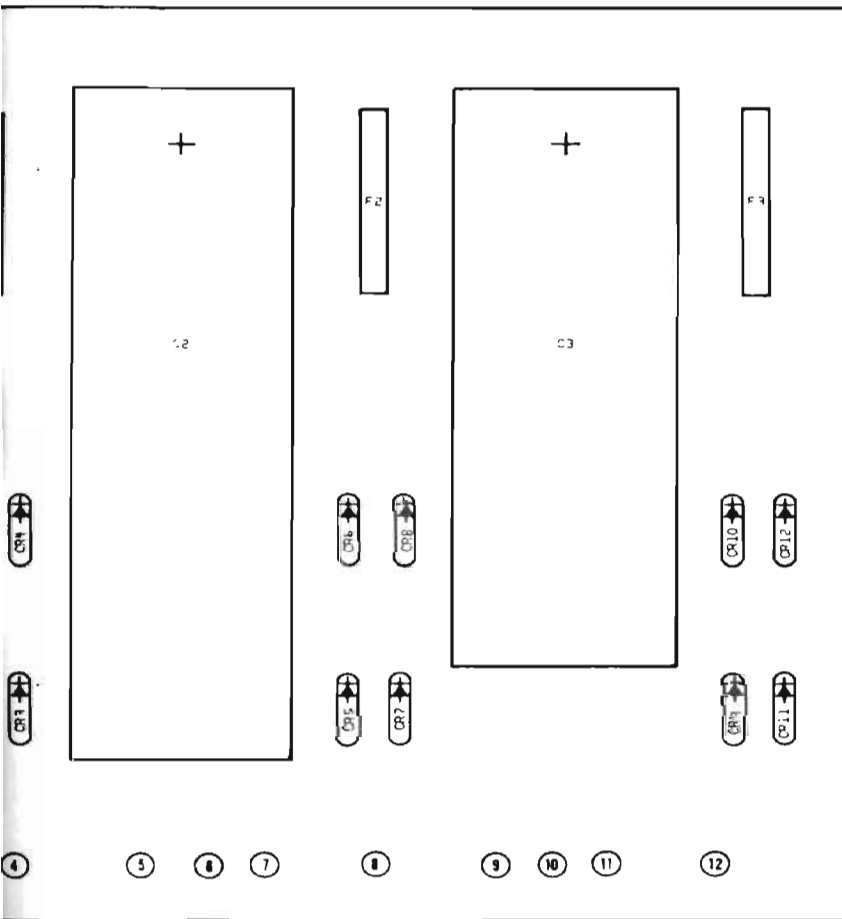

- NOTES:
1. RESISTORS - 1/4W, 5% VALUES IN OHMS UNLESS OTHERWISE NOTED.
 2. CAPACITORS - VALUES IN μ F UNLESS OTHERWISE NOTED.
 3. INDUCTORS - VALUES IN μ H UNLESS OTHERWISE NOTED.
 4. *FACTORY SELECT, TYPICAL VALUE SHOWN.
 5. ALL VOLTAGES ARE DC UNLESS OTHERWISE NOTED.

Figure 6-12. Power Supply Rectifier. A13

DIVIDE-BY-N, A14

CKT. REF.	DESCRIPTION	CE STOCK NO.	MFR.	MFR. NO.
A14	Divide-By-N P. C. Board Assy	7001-0214	Cushman	
	P. C. Board	1780-0089	Cushman	
CAPACITORS				
C1	Cer, .05 μ F, +80% -20%, 25V	1005-0014	Erie	5855-505-Y5U0-503Z
C2	Cer, .01 μ F, +80% -20%, 25V	1005-0013	Erie	5835-512-Y5U-103Z
C3	Cer, .05 μ F, +80% -20%, 25V	1005-0014	Erie	5855-505-Y5U0-503Z
C4	Elect, 15 μ F, +75% -10%, 12V	1013-0015	Sprague	30D156G012CC5
C5	Cer, .05 μ F, +80% -20%, 25V	1005-0014	Erie	5855-505-Y5U0-503Z
C6	Cer, .05 μ F, +80% -20%, 25V	1005-0014	Erie	5855-505-Y5U0-503Z
C7	Cer, .05 μ F, +80% -20%, 25V	1005-0014	Erie	5855-505-Y5U0-503Z
C8	Cer, .05 μ F, +80% -20%, 25V	1005-0014	Erie	5855-505-Y5U0-503Z
C9	Cer, .05 μ F, +80% -20%, 25V	1005-0014	Erie	5855-505-Y5U0-503Z
C10	Cer, .05 μ F, +80% -20%, 25V	1005-0014	Erie	5855-505-Y5U0-503Z
C11	Cer, .05 μ F, +80% -20%, 25V	1005-0014	Erie	5855-505-Y5U0-503Z
C12	Elect, 15 μ F, +75% -10%, 12V	1013-0015	Sprague	30D156G012CC5
C13	Cer, .05 μ F, +80% -20%, 25V	1005-0014	Erie	5855-505-Y5U0-503Z
C14	Cer, .05 μ F, +80% -20%, 25V	1005-0014	Erie	5855-505-Y5U0-503Z
C15	Cer, .05 μ F, +80% -20%, 25V	1005-0014	Erie	5855-505-Y5U0-503Z
C16	Poly, .1 μ F, \pm 10%, 100V	1008-0031	Sprague	225P10491
COILS				
L1	RF Choke, 12 μ H, \pm 10%	1585-0011	Delevan	1537-38
L2	RF Choke, 47 μ H, \pm 5%	1585-0010	Delevan	1537-60
L3	RF Choke, 47 μ H, \pm 5%	1585-0010	Delevan	1537-60
L4	RF Choke, 12 μ H, \pm 10%	1585-0011	Delevan	1537-38
DIODES				
CR1	Si, 1 amp, 100V PIV	1281-0023	ITT	1N4002
CR2	Si, 1 amp, 100V PIV	1281-0023	ITT	1N4002
CR3	Si, 1N3064	1281-0013	Sylvania	1N3064
CR4	Si, 1N3064	1281-0013	Sylvania	1N3064
CR5	Si, 1N3064	1281-0013	Sylvania	1N3064
INTEGRATED CIRCUITS				
IC1	50 MHz, Presettable Decade	2025-0016	T. I.	SN74196N
IC2	50 MHz, Presettable Decade	2025-0016	T. I.	SN74196N
IC3	50 MHz, Presettable Decade	2025-0016	T. I.	SN74196N
IC4	50 MHz, Presettable Decade	2025-0016	T. I.	SN74196N
IC5	Quad, 8-input Pos. NAND Gate	2025-0004	T. I.	SN7430
IC6	50 MHz, Presettable Decade	2025-0016	T. I.	SN74196N
IC7	Triple 3-input Pos. AND Gate	2025-0017	T. I.	SN74H11N
IC8	TTL Dual Flip-Flop	2025-0007	T. I.	SN7472N
IC9	50 MHz, Presettable Decade	2025-0016	T. I.	SN74196N
IC10	Quad, 2-input Pos. NAND Gate	2025-0003	T. I.	SN7400N
IC11	Dual, 2-input, NOR Gate	2025-0010	Fairchild	U8A-9914-28X
RESISTORS				
R1	Comp, 120 Ω , \pm 5%, 1/4W	1066-1215	Allen-Bradley	CB1215
R2	Comp, 560 Ω , \pm 5%, 1/4W	1066-5615	Allen-Bradley	CB5615
R3	Comp, 1.2k Ω , \pm 5%, 1/4W	1066-1225	Allen-Bradley	CB1225
R4	Comp, 1.2k Ω , \pm 5%, 1/4W	1066-1225	Allen-Bradley	CB1225
R5	Comp, 220 Ω , \pm 5%, 1/4W	1066-2215	Allen-Bradley	CB2215

DIVIDE-BY-N (cont). A14

CKT. REF.	DESCRIPTION	CE STOCK NO.	MFR.	MFR. NO.
R6	Comp, 12 Ω , $\pm 5\%$, 1/4W	1066-1205	Allen-Bradley	CB1205
R7	Comp, 470 Ω , $\pm 5\%$, 1/4W	1066-4715	Allen-Bradley	CB4715
R8	Comp, 1.2k Ω , $\pm 5\%$, 1/4W	1066-1225	Allen-Bradley	CB1225
R9	Comp, 2.7k Ω , $\pm 5\%$, 1/4W	1066-2725	Allen-Bradley	CB2725
R10	Comp, 2.7k Ω , $\pm 5\%$, 1/4W	1066-2725	Allen-Bradley	CB2725
R11	Comp, 2.7k Ω , $\pm 5\%$, 1/4W	1066-2725	Allen-Bradley	CB2725
R12	Comp, 2.7k Ω , $\pm 5\%$, 1/4W	1066-2725	Allen-Bradley	CB2725
R13	Comp, 2.7k Ω , $\pm 5\%$, 1/4W	1066-2725	Allen-Bradley	CB2725
R14	Comp, 2.7k Ω , $\pm 5\%$, 1/4W	1066-2725	Allen-Bradley	CB2725
R15	Comp, 2.7k Ω , $\pm 5\%$, 1/4W	1066-2725	Allen-Bradley	CB2725
R16	Comp, 2.7k Ω , $\pm 5\%$, 1/4W	1066-2725	Allen-Bradley	CB2725
R17	Comp, 2.7k Ω , $\pm 5\%$, 1/4W	1066-2725	Allen-Bradley	CB2725
R18	Comp, 2.7k Ω , $\pm 5\%$, 1/4W	1066-2725	Allen-Bradley	CB2725
R19	Comp, 2.7k Ω , $\pm 5\%$, 1/4W	1066-2725	Allen-Bradley	CB2725
R20	Comp, 2.7k Ω , $\pm 5\%$, 1/4W	1066-2725	Allen-Bradley	CB2725
R21	Comp, 2.7k Ω , $\pm 5\%$, 1/4W	1066-2725	Allen-Bradley	CB2725
R22	Comp, 2.7k Ω , $\pm 5\%$, 1/4W	1066-2725	Allen-Bradley	CB2725
R23	Comp, 2.7k Ω , $\pm 5\%$, 1/4W	1066-2725	Allen-Bradley	CB2725
R24	Comp, 2.7k Ω , $\pm 5\%$, 1/4W	1066-2725	Allen-Bradley	CB2725
R25	Comp, 1.2k Ω , $\pm 5\%$, 1/4W	1066-1225	Allen-Bradley	CB1225
R26	Comp, 4.7k Ω , $\pm 5\%$, 1/4W	1066-4725	Allen-Bradley	CB4725
R27	Comp, 2.7k Ω , $\pm 5\%$, 1/4W	1066-2725	Allen-Bradley	CB2725
R28	Comp, 2.7k Ω , $\pm 5\%$, 1/4W	1066-2725	Allen-Bradley	CB2725
R29	Comp, 2.7k Ω , $\pm 5\%$, 1/4W	1066-2725	Allen-Bradley	CB2725
	TRANSISTORS			
Q1	Si, NPN, 2N3563	1272-0022	Fairchild	2N3563
Q2	Si, NPN, 2N3563	1272-0022	Fairchild	2N3563
Q3	Si, PNP, 2N4121	1272-0023	Fairchild	2N4121
Q4	Si, NPN, 2N4275	1272-0016	Fairchild	2N4275

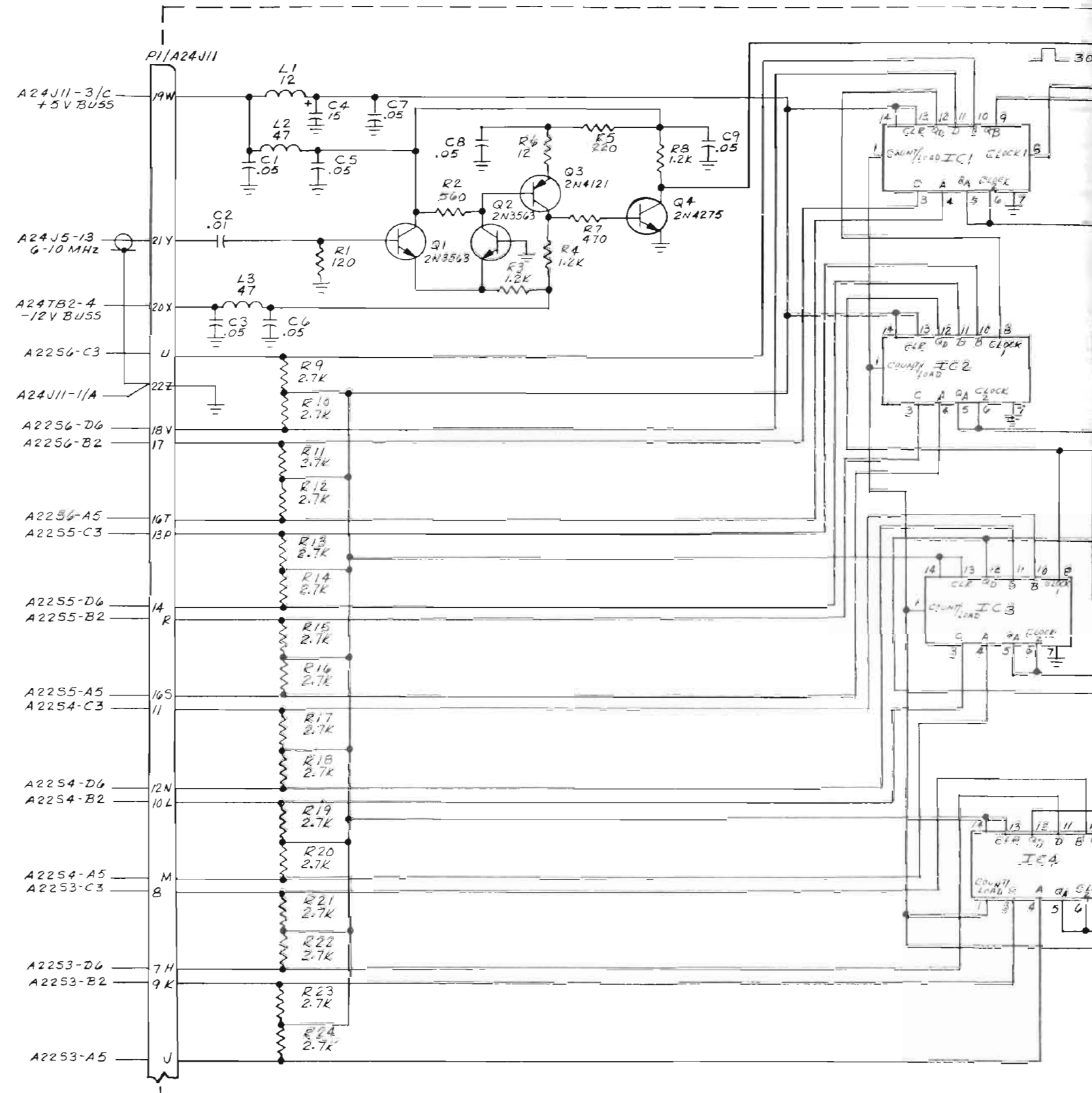
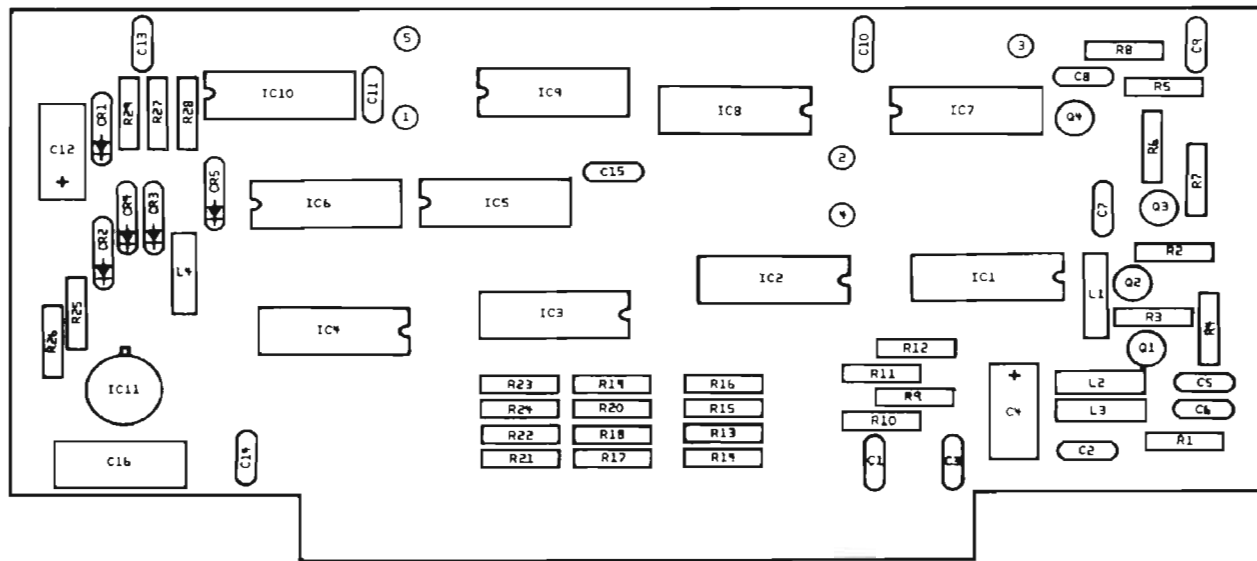

NOTE:
 1. RESISTORS - 1/4W, 5% VALUES IN OHMS UNLESS OTHERWISE NOTED.
 2. CAPACITORS - VALUES IN μ F UNLESS OTHERWISE NOTED.
 3. INDUCTORS - VALUES IN μ H UNLESS OTHERWISE NOTED.
 4. *FACTORY SELECT. TYPICAL VALUES SHOWN.
 5. ALL VOLTAGES ARE DC UNLESS OTHERWISE NOTED.

IS NO	TYPE	TERMS	NO
1,2,3,4,6,9	5N74192N	VECT	STND
5	5N74192N	72	7
7	5N74192N	16	7
8	5N74192N	14	7
10	5N74192N	14	7
11	4918	8	4

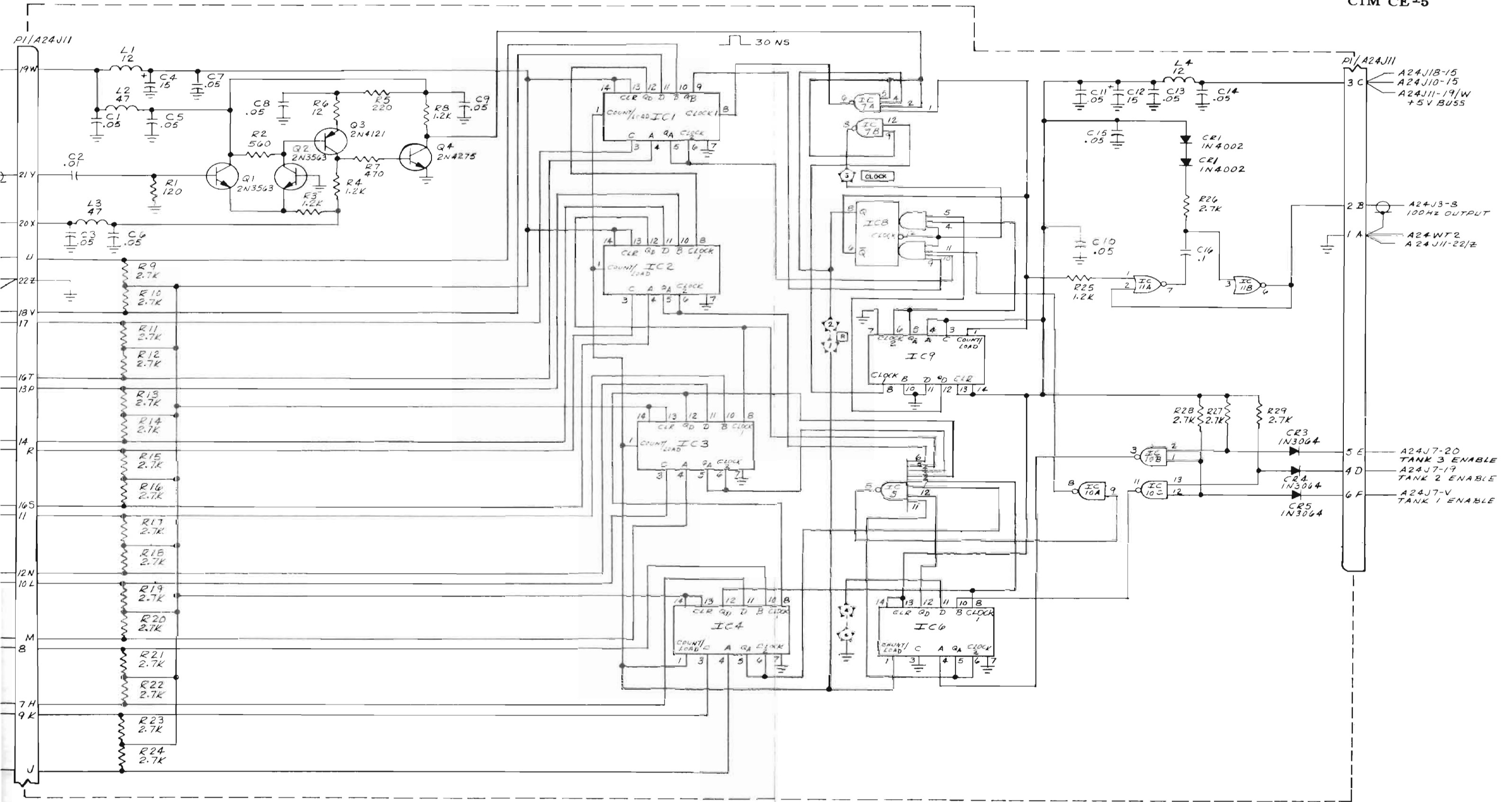

- NOTE:
1. RESISTORS - 1/4W, 5% VALUES IN OHMS UNLESS OTHERWISE NOTED.
 2. CAPACITORS - VALUES IN μ F UNLESS OTHERWISE NOTED.
 3. INDUCTORS - VALUES IN μ H UNLESS OTHERWISE NOTED.
 4. *FACTORY SELECT - TYPICAL VALUE SHOWN.
 5. ALL VOLTAGES ARE DC UNLESS OTHERWISE NOTED.

IC NO'S	TYPE	TERM NO	REF	QTY
1,2,3,4,6,9	SN74192N	14	7	6
5	SN7420	14	7	1
7	SN7411N	14	7	1
8	SN7472N	14	7	1
10	SN7400N	14	7	1
11	9914	8	4	1

Figure 6-13. Divide-by-N. A14

SWITCHING LOGIC, A15

CKT. REF.	DESCRIPTION	CE STOCK NO.	MFR.	MFR. NO.
A15	Switching Logic, P.C. Board Assy	7001-0215	Cushman	
	P.C. Board	1780-0450	Cushman	
CAPACITORS				
C1	Elect, 100 μ F, +75% -10%, 12V	1013-0011	Sprague	30D107G012CC5
C2	Cer, .1 μ F, \pm 20%, 25V	1005-0044	Sprague	5C023104X0250B3
C3	Cer, Min, .1 μ F, \pm 20%, 50V	1005-0097	Emcap	5020ES250RD104M
C4	Cer, .1 μ F, \pm 20%, 25V	1005-0044	Sprague	5C023104X0250B3
INTEGRATED CIRCUITS				
IC1	4-wide 2-input AND-or-INVERT Gates	2025-0063	T.I.	SN7454N
IC2	4-wide 2-input AND-or-INVERT Gates	2025-0063	T.I.	SN7454N
IC3	4-wide 2-input AND-or-INVERT Gates	2025-0063	T.I.	SN7454N
IC4	4-wide 2-input AND-or-INVERT Gates	2025-0063	T.I.	SN7454N
IC5	4-wide 2-input AND-or-INVERT Gates	2025-0063	T.I.	SN7454N
IC6	Hex Inverter, SN7404N	2025-0048	T.I.	SN7404N
IC7	Hex Inverter, SN7404N	2025-0048	T.I.	SN7404N
IC8	Triple 3-input NAND Gate	2025-0047	T.I.	SN7410N
IC9	Quad, 2-input Pos NAND Gate	2025-0003	T.I.	SN7400N
IC10	Quad, 2-input Pos NAND Gate	2025-0003	T.I.	SN7400N
IC11	Hex Inverter, SN7404N	2025-0048	T.I.	SN7404N
IC12	Hex Inverter, SN7404N	2025-0048	T.I.	SN7404N
IC13	4-wide 2-input AND-or-INVERT Gates	2025-0063	T.I.	SN7454N
IC14	Quad, 2-input Pos NAND Gate	2025-0003	T.I.	SN7400N
IC15	Triple 3-input NAND Gate	2025-0047	T.I.	SN7410N
IC16	Quad, 2-input Pos. NAND Gate	2025-0003	T.I.	SN7400N
IC17	Quad, 2-input Pos. NOR Gate	2025-0059	T.I.	SN7402N
IC18	Hex Inverter, SN7404N	2025-0048	T.I.	SN7404N
IC19	Quad, 2-input Pos. NAND Gate	2025-0003	T.I.	SN7400N
IC20	Quad, 2-input Pos. NOR Gate	2025-0059	T.I.	SN7402N
RESISTORS				
R1	Comp, 10k Ω , \pm 5%, 1/4W	1066-1035	Allen-Bradley	CB1035
R2	Comp, 1k Ω , \pm 5%, 1/4W	1066-1025	Allen-Bradley	CB1025
R3	Comp, 1k Ω , \pm 5%, 1/4W	1066-1025	Allen-Bradley	CB1025
R4	Comp, 1k Ω , \pm 5%, 1/4W	1066-1025	Allen-Bradley	CB1025
R5	Comp, 1k Ω , \pm 5%, 1/4W	1066-1025	Allen-Bradley	CB1025
R6	Comp, 1k Ω , \pm 5%, 1/4W	1066-1025	Allen-Bradley	CB1025
R7	Comp, 220 Ω , \pm 5%, 1/4W	1066-2215	Allen-Bradley	CB2215
R8	Comp, 560 Ω , \pm 5%, 1/4W	1066-5615	Allen-Bradley	CB5615
R9	Comp, 2.2k Ω , \pm 5%, 1/4W	1066-2225	Allen-Bradley	CB2225
R10	Comp, 1k Ω , \pm 5%, 1/4W	1066-1025	Allen-Bradley	CB1025
R11	Comp, 10k Ω , \pm 5%, 1/4W	1066-1035	Allen-Bradley	CB1035
R12	Comp, 10k Ω , \pm 5%, 1/4W	1066-1035	Allen-Bradley	CB1035
R13	Comp, 1k Ω , \pm 5%, 1/4W	1066-1025	Allen-Bradley	CB1025
R14	Comp, 10k Ω , \pm 5%, 1/4W	1066-1035	Allen-Bradley	CB1035
R15	Comp, 10k Ω , \pm 5%, 1/4W	1066-1035	Allen-Bradley	CB1035
R16	Comp, 1k Ω , \pm 5%, 1/4W	1066-1025	Allen-Bradley	CB1025
R17	Comp, 10k Ω , \pm 5%, 1/4W	1066-1035	Allen-Bradley	CB1035
R18	Comp, 10k Ω , \pm 5%, 1/4W	1066-1035	Allen-Bradley	CB1035

SWITCHING LOGIC (cont). A15

CKT. REF.	DESCRIPTION	CE STOCK NO.	MFR.	MFR. NO.
TRANSISTORS				
Q1	Si, NPN, 2N4275	1272-0016	Fairchild	2N4275
Q2	Si, NPN, 2N4275	1272-0016	Fairchild	2N4275
Q3	Si, NPN, 2N4275	1272-0016	Fairchild	2N4275
Q4	Si, NPN, 2N4275	1272-0016	Fairchild	2N4275
Q5	Si, NPN, 2N4275	1272-0016	Fairchild	2N4275
Q6	Si, PNP, MPS U56	1272-0052	Motorola	MPS U56
Q7	Si, PNP, MPS U56	1272-0052	Motorola	MPS U56
Q8	Si, NPN, 2N4275	1272-0016	Fairchild	2N4275
Q9	Si, PNP, MPS U56	1272-0052	Motorola	MPS U56
Q10	Si, NPN, 2N4275	1272-0016	Fairchild	2N4275
Q11	Si, PNP, MPS U56	1272-0052	Motorola	MPS U56
Q12	Si, NPN, 2N4275	1272-0016	Fairchild	2N4275

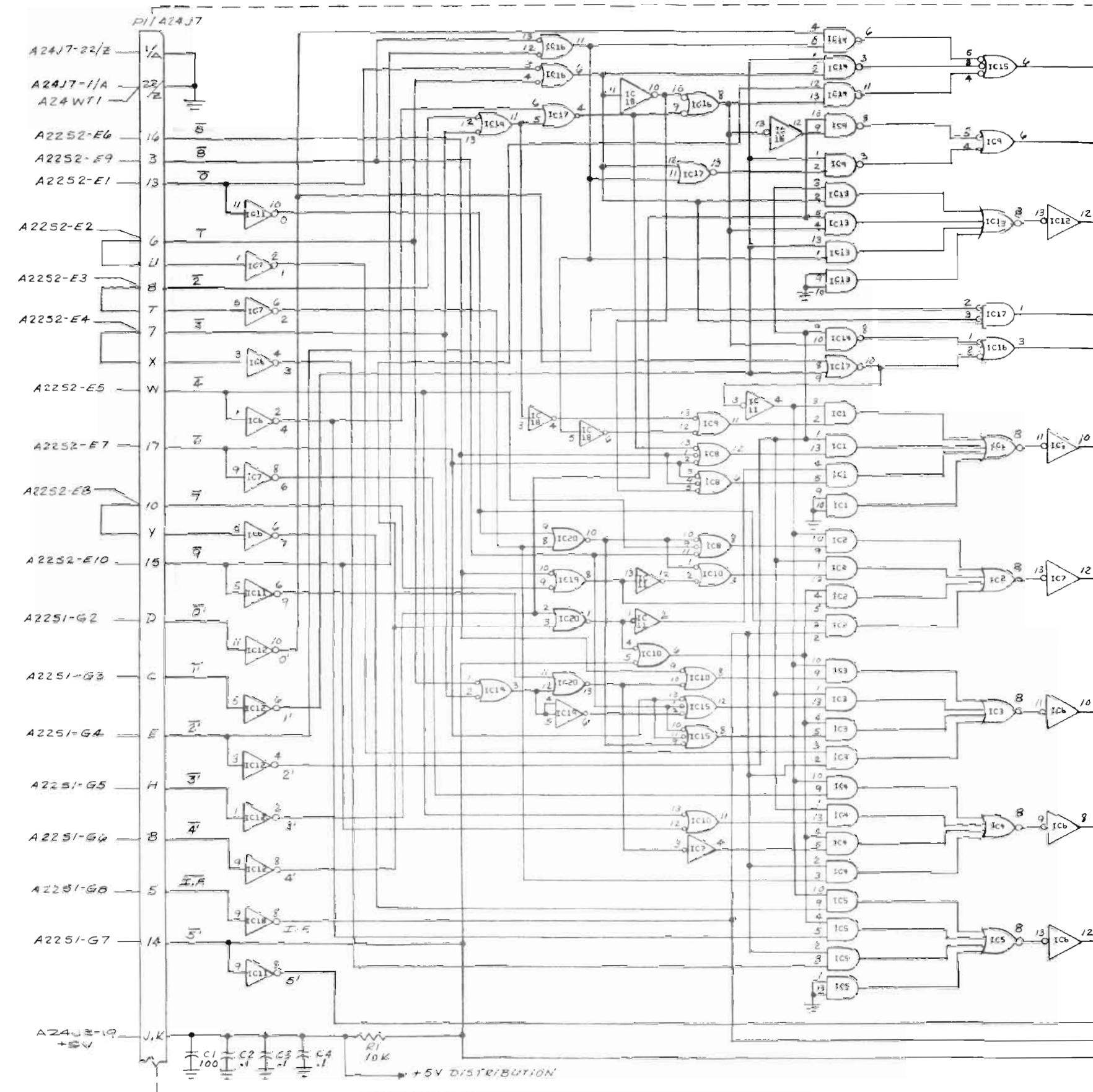
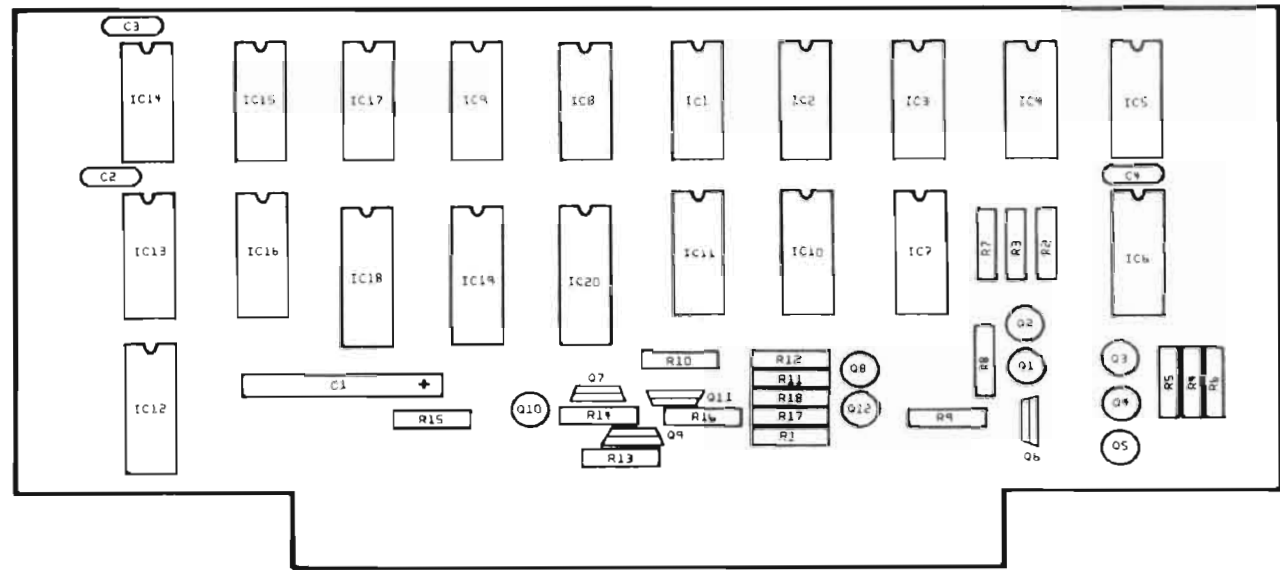

NOTE:

1. RESISTORS - 1/4W, 5% VALUES IN OHMS UNLESS OTHERWISE NOTED.
2. CAPACITORS - VALUES IN μ F UNLESS OTHERWISE NOTED.
3. INDUCTORS - VALUES IN μ H UNLESS OTHERWISE NOTED.
4. FACTORY SELECT - TYPICAL VALUE SHOWN.
5. ALL VOLTAGES ARE DC UNLESS OTHERWISE NOTED.

IC NO.	...
1, 2, 3, 4, 5, 13	5
8, 15	5
9, 10, 14, 16, 19	5
17, 20	5
6, 7, 11, 12, 18	5

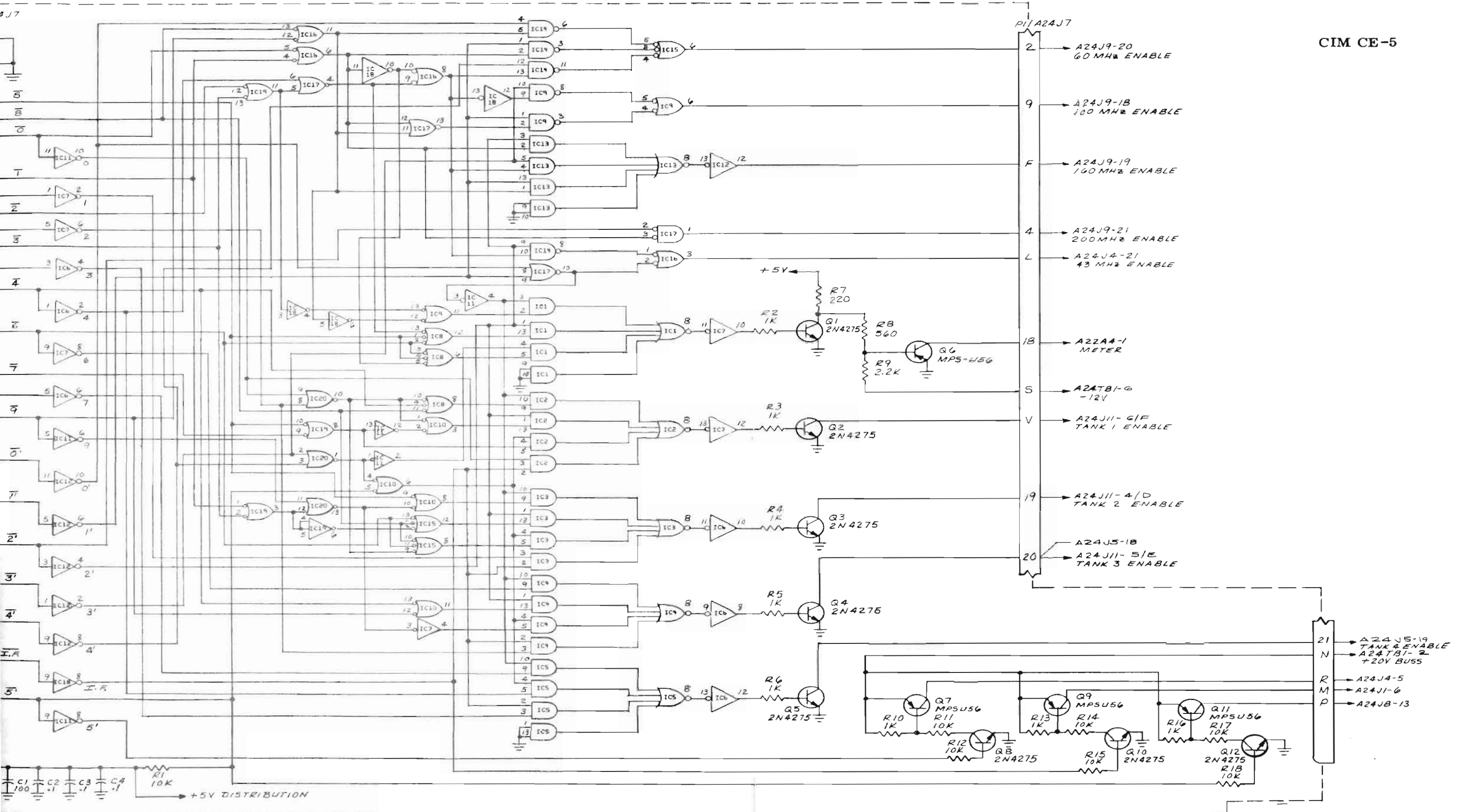

RESISTORS - 1/4W, 5% VALUES IN OHMS UNLESS OTHERWISE NOTED.
 CAPACITORS - VALUES IN μF UNLESS OTHERWISE NOTED.
 INDUCTORS - VALUES IN μH UNLESS OTHERWISE NOTED.
 FACTORY SELECT. TYPICAL VALUE SHOWN.
 ALL VOLTAGES ARE DC UNLESS OTHERWISE NOTED.

IC NO.	PART NO.
1, 2, 3, 4, 5, 13	SN7454N
8, 15	SN7410N
9, 10, 14, 16, 19, 14	SN7400N
17, 20	SN7402N
6, 7, 11, 12, 18	SN7404N

Figure 6-14. Switching Logic. A15

42 MHz FILTER, AUDIO AMPLIFIER, MIXER AND IF SWITCHING. A16

CKT. REF.	DESCRIPTION	CE STOCK NO.	MFR.	MFR. NO.
A16	42 MHz Filter, Audio Ampl, Mixer & IF Switching P.C. Board Assy	7001-0216	Cushman	
	P.C. Board	1780-0451	Cushman	
CAPACITORS				
C1	Cer, .05 μ F, +80% -20%, 25V	1005-0014	Erie	5855-505-Y5U0-503Z
C2	Poly, .1 μ F, \pm 10%, 100V	1008-0031	Sprague	225P10491
C3	Poly, .1 μ F, \pm 10%, 100V	1008-0031	Sprague	225P10491
C4	Cer, .05 μ F, +80% -20%, 25V	1005-0014	Erie	5855-505-Y5U0-503Z
C5	Elect, 1.0 μ F, \pm 10%, 25V	1013-0004	Sprague	30D105G025BA5
C6	Cer, .05 μ F, +80% -20%, 25V	1005-0014	Erie	5855-505-Y5U0-503Z
C7	Mica, 51pF, \pm 5%, 500V	1002-0045	Elmenco	DM15-E-510J
C8	Elect, 100 μ F, \pm 10%, 25V	1013-0003	Sprague	30D107G025DD5
C9	Mica, 470pF, \pm 5%, 500V	1002-0035	Elmenco	DM15-F-471J
C10	Poly, .1 μ F, \pm 10%, 100V	1008-0031	Sprague	225P10491
C11	Poly, .1 μ F, \pm 10%, 100V	1008-0031	Sprague	225P10491
C12	Elect, 250 μ F, +75% -10%, 16V	1013-0016	Sprague	30D257G016DF2
C13	Cer, .002 μ F, \pm 20%, 500V	1005-0003	Erie	831-596-Z5U-202M
C14	Mica, 91pF, \pm 5%, 500V	1002-0027	Elmenco	DM15-F-910J
C15	Cer, 3.3pF, \pm .25pF, 500V	1005-0011	Erie	301-000-C0J0-339C
C16	Cer, .002 μ F, \pm 20%, 500V	1005-0003	Erie	831-596-Z5U-202M
C17	Cer, .002 μ F, \pm 20%, 500V	1005-0003	Erie	831-596-Z5U-202M
C18	Mica, 91pF, \pm 5%, 500V	1002-0027	Elmenco	DM15-F-910J
C19	Cer, .002 μ F, \pm 20%, 500V	1005-0003	Erie	831-596-Z5U-202M
C20	Cer, 3.3pF, \pm .25pF, 500V	1005-0011	Erie	301-000-C0J0-339C
C21	Cer, .002 μ F, \pm 20%, 500V	1005-0003	Erie	831-596-Z5U-202M
C22	Cer, .002 μ F, \pm 20%, 500V	1005-0003	Erie	831-596-Z5U-202M
C23	Mica, 91pF, \pm 5%, 500V	1002-0027	Elmenco	DM15-F-910J
C24	Cer, .002 μ F, \pm 20%, 500V	1005-0003	Erie	831-596-Z5U-202M
C25	Cer, 3.3pF, \pm .25pF, 500V	1005-0011	Erie	301-000-C0J0-339C
C26	Cer, .002 μ F, \pm 20%, 500V	1005-0003	Erie	831-596-Z5U-202M
C27	Cer, .002 μ F, \pm 20%, 500V	1005-0003	Erie	831-596-Z5U-202M
C28	Cer, .05 μ F, +80% -20%, 25V	1005-0014	Erie	5855-505-Y5U0-503Z
C29	Mica, 91pF, \pm 5%, 500V	1002-0027	Elmenco	DM15-F-910J
C30	Cer, 3.3pF, \pm .25pF, 500V	1005-0011	Erie	301-000-C0J0-339C
C31	Cer, .002 μ F, \pm 20%, 500V	1005-0003	Erie	831-596-Z5U-202M
C32	Mica, 15pF, \pm 5%, 500V	1002-0001	Elmenco	DM15-C-150J
C33	Mica, 20pF, \pm 5%, 500V	1002-0060	Elmenco	DM15-200J
COILS				
L1	RF Choke, 220 μ H, \pm 5%	1585-0018	Delevan	1537-92
L2	Var. Inductor, 4 turns	1596-0010	Cushman	
L3	Var. Inductor, 4 turns	1596-0010	Cushman	
L4	Var. Inductor, 4 turns	1596-0010	Cushman	
L5	RF Choke, 15 μ H, \pm 10%	1585-0034	Delevan	1437-40
L6	Var. Inductor, 4 turns	1596-0010	Cushman	
L7	RF Choke, 15 μ H, \pm 10%	1585-0034	Delevan	1437-40
DIODES				
CR1	Ge, G633	1282-0005	ITT	G633
CR2	Si, 1N3064	1281-0013	Sylvania	1N3064
CR3	Si, 1N3064	1281-0013	Sylvania	1N3064
CR4	Ge, G633	1282-0005	ITT	G633
INTEGRATED CIRCUITS				
IC1	Audio Power Ampl	2025-0060	Motorola	MFC 6070
IC2	Quad, 2-input Pos. NAND Gate	2025-0003	T.I.	SN7400N
IC3	Quad, 2-input Pos. NAND Gate	2025-0003	T.I.	SN7400N

42 MHz FILTER, AUDIO AMPLIFIER, MIXER AND IF SWITCHING (cont). A16

CKT. REF.	DESCRIPTION	CE STOCK NO.	MFR.	MFR. NO.
RESISTORS				
R1	Comp, 33k Ω , $\pm 5\%$, 1/4W	1066-3335	Allen-Bradley	CB3335
R2	Comp, 1Meg, $\pm 5\%$, 1/4W	1066-1055	Allen-Bradley	CB1055
R3	Comp, 10k Ω , $\pm 5\%$, 1/4W	1066-1035	Allen-Bradley	CB1035
R4	Comp, 5.1k Ω , $\pm 5\%$, 1/4W	1066-5125	Allen-Bradley	CB5125
R5	Comp, 5.6k Ω , $\pm 5\%$, 1/4W	1066-5625	Allen-Bradley	CB5625
R6	Comp, 10k Ω , $\pm 5\%$, 1/4W	1066-1035	Allen-Bradley	CB1035
R7	Comp, 180k Ω , $\pm 5\%$, 1/4W	1066-1845	Allen-Bradley	CB1845
R8	Comp, 10k Ω , $\pm 5\%$, 1/4W	1066-1035	Allen-Bradley	CB1035
R9	Comp, 10k Ω , $\pm 5\%$, 1/4W	1066-1035	Allen-Bradley	CB1035
R10	Comp, 16k Ω , $\pm 5\%$, 1/4W	1066-1635	Allen-Bradley	CB1635
R11	Comp, 62 Ω , $\pm 5\%$, 1W	1068-6205	Allen-Bradley	GB6205
R12	Comp, 1Meg, $\pm 5\%$, 1/4W	1066-1055	Allen-Bradley	CB1055
R13	Comp, 820k Ω , $\pm 5\%$, 1/4W	1066-8245	Allen-Bradley	CB8245
R14	Comp, 220 Ω , $\pm 5\%$, 1/4W	1066-2215	Allen-Bradley	CB2215
R15	Comp, 2Meg, $\pm 5\%$, 1/4W	1066-2055	Allen-Bradley	CB2055
R16	Comp, 6.8k Ω , $\pm 5\%$, 1/4W	1066-6825	Allen-Bradley	CB6825
R17	Comp, 6.8k Ω , $\pm 5\%$, 1/4W	1066-6825	Allen-Bradley	CB6825
R18	Comp, 10 Ω , $\pm 5\%$, 1/4W	1066-1005	Allen-Bradley	CB1005
R19	Comp, 560 Ω , $\pm 5\%$, 1/4W	1066-5615	Allen-Bradley	CB5615
R20	Comp, 10k Ω , $\pm 5\%$, 1/4W	1066-1035	Allen-Bradley	CB1035
R21	Comp, 1k Ω , $\pm 5\%$, 1/4W	1066-1025	Allen-Bradley	CB1025
R22	Comp, 10k Ω , $\pm 5\%$, 1/4W	1066-1035	Allen-Bradley	CB1035
R23	Comp, 5.1k Ω , $\pm 5\%$, 1/4W	1066-5125	Allen-Bradley	CB5125
R24	Comp, 5.1k Ω , $\pm 5\%$, 1/4W	1066-5125	Allen-Bradley	CB5125
R25	Comp, 10k Ω , $\pm 5\%$, 1/4W	1066-1035	Allen-Bradley	CB1035
R26	Comp, 10k Ω , $\pm 5\%$, 1/4W	1066-1035	Allen-Bradley	CB1035
R27	Comp, 3.9k Ω , $\pm 5\%$, 1/4W	1066-3925	Allen-Bradley	CB3925
R28	Comp, 10k Ω , $\pm 5\%$, 1/4W	1066-1035	Allen-Bradley	CB1035
R29	Comp, 10k Ω , $\pm 5\%$, 1/4W	1066-1035	Allen-Bradley	CB1035
R30	Comp, 10k Ω , $\pm 5\%$, 1/4W	1066-1035	Allen-Bradley	CB1035
R31	Comp, 10k Ω , $\pm 5\%$, 1/4W	1066-1035	Allen-Bradley	CB1035
R32	Comp, 10k Ω , $\pm 5\%$, 1/4W	1066-1035	Allen-Bradley	CB1035
R33	Comp, 10k Ω , $\pm 5\%$, 1/4W	1066-1035	Allen-Bradley	CB1035
R34	Comp, 1k Ω , $\pm 5\%$, 1/4W	1066-1025	Allen-Bradley	CB1025
R35	Comp, 10k Ω , $\pm 5\%$, 1/4W	1066-1035	Allen-Bradley	CB1035
R36	Comp, 33k Ω , $\pm 5\%$, 1/4W	1066-3335	Allen-Bradley	CB3335
R37	Comp, 1k Ω , $\pm 5\%$, 1/4W	1066-1025	Allen-Bradley	CB1025
R38	Comp, 10k Ω , $\pm 5\%$, 1/4W	1066-1035	Allen-Bradley	CB1035
R39	Comp, 1k Ω , $\pm 5\%$, 1/4W	1066-1025	Allen-Bradley	CB1025
R40	Comp, 10k Ω , $\pm 5\%$, 1/4W	1066-1035	Allen-Bradley	CB1035
R41	Comp, 3.9k Ω , $\pm 5\%$, 1/4W	1066-3925	Allen-Bradley	CB3925
R42	Comp, 10k Ω , $\pm 5\%$, 1/4W	1066-1035	Allen-Bradley	CB1035
R43	Comp, 1k Ω , $\pm 5\%$, 1/4W	1066-1025	Allen-Bradley	CB1025
R44	Comp, 1k Ω , $\pm 5\%$, 1/4W	1066-1025	Allen-Bradley	CB1025
R45	Comp, 10k Ω , $\pm 5\%$, 1/4W	1066-1035	Allen-Bradley	CB1035
R46	Comp, 5.1k Ω , $\pm 5\%$, 1/4W	1066-5125	Allen-Bradley	CB5125
R47	Comp, 5.1k Ω , $\pm 5\%$, 1/4W	1066-5125	Allen-Bradley	CB5125
R48	Comp, 10k Ω , $\pm 5\%$, 1/4W	1066-1035	Allen-Bradley	CB1035
R49	Comp, 10k Ω , $\pm 5\%$, 1/4W	1066-1035	Allen-Bradley	CB1035
R50	Comp, 10k Ω , $\pm 5\%$, 1/4W	1066-1035	Allen-Bradley	CB1035
R51	Comp, 1k Ω , $\pm 5\%$, 1/4W	1066-1025	Allen-Bradley	CB1025
R52	Comp, 1k Ω , $\pm 5\%$, 1/4W	1066-1025	Allen-Bradley	CB1025
R53	Comp, 56k Ω , $\pm 5\%$, 1/4W	1066-5635	Allen-Bradley	CB5635
R54	Comp, 5.1k Ω , $\pm 5\%$, 1/4W	1066-5125	Allen-Bradley	CB5635
R55	Comp, 10k Ω , $\pm 5\%$, 1/4W	1066-1035	Allen-Bradley	CB1035

42 MHz FILTER, AUDIO AMPLIFIER, MIXER AND IF SWITCHING (cont). A16

CKT. REF.	DESCRIPTION	CE STOCK NO.	MFR.	MFR. NO.
	TRANSISTORS			
Q1	Si, NPN, 2N4275	1272-0016	Fairchild	2N4275
Q2	Si, NPN, 2N4275	1272-0016	Fairchild	2N4275
Q3	Si, NPN, 2N4275	1272-0016	Fairchild	2N4275
Q4	Si, NPN, 2N4275	1272-0016	Fairchild	2N4275
Q5	Si, NPN, 2N3563	1272-0022	Fairchild	2N3563
Q6	Si, NPN, 2N4275	1272-0016	Fairchild	2N4275
Q7	Si, PNP, 2N4121	1272-0023	Fairchild	2N4121
Q8	Si, PNP, TIS 37	1271-0003	T.I.	TIS 37
Q9	Si, NPN, 2N4275	1272-0016	Fairchild	2N4275
Q10	Si, NPN, 2N4275	1272-0016	Fairchild	2N4275
Q11	Si, NPN, 2N4275	1272-0016	Fairchild	2N4275
Q12	Si, NPN, 2N4275	1272-0016	Fairchild	2N4275
Q13	Si, PNP, TIS 37	1271-0003	T.I.	TIS 37
Q14	Si, PNP, MPS U56	1272-0052	Motorola	MPS U56
Q15	Si, NPN, 2N4275	1272-0016	Fairchild	2N4275
Q16	Si, PNP, 2N4121	1272-0023	Fairchild	2N4121
Q17	Si, PNP, 2N4121	1272-0023	Fairchild	2N4121
Q18	Si, NPN, MPS U06	1272-0053	Motorola	MPS U06
Q19	Si, PNP, 2N4121	1272-0023	Fairchild	2N4121
Q20	Si, NPN, MPS U06	1272-0053	Motorola	MPS U06
Q21	Si, PNP, TIS 37	1271-0003	T.I.	TIS 37

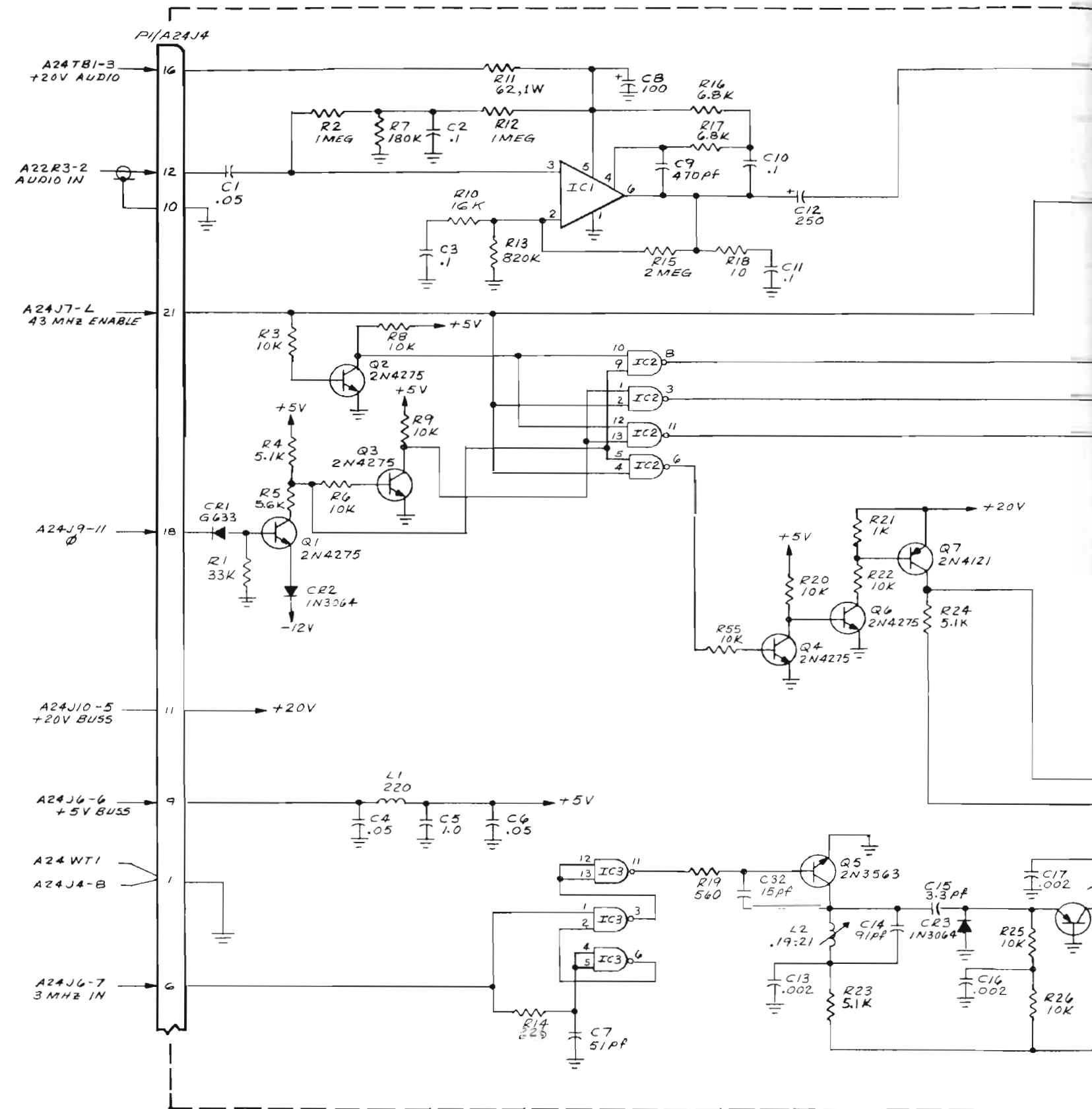
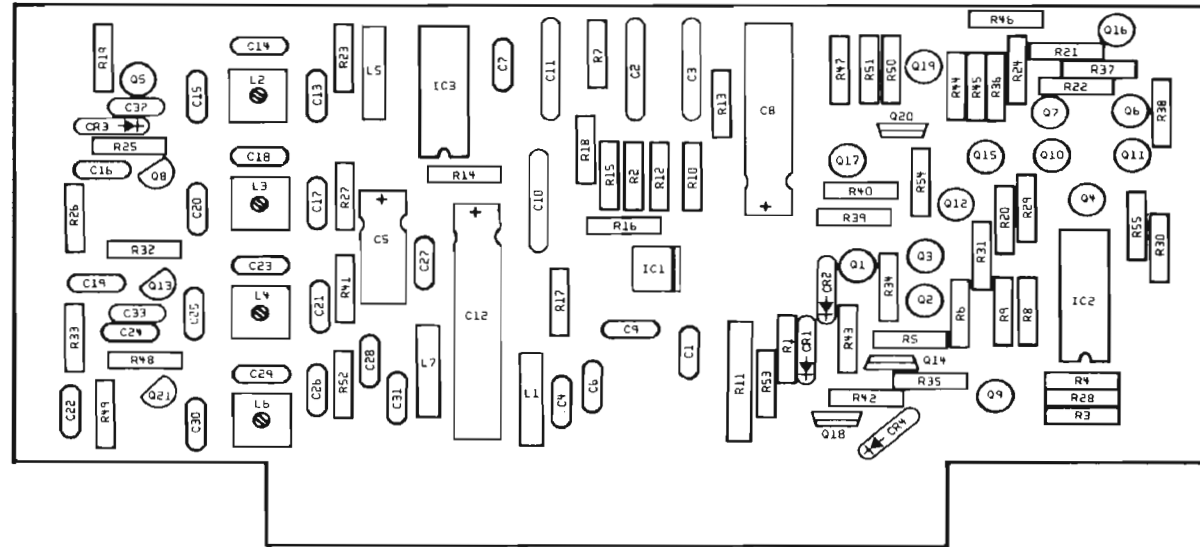

NOTE:

1. RESISTORS - 1/4W, 5% VALUES IN OHMS UNLESS OTHERWISE NOTED.
2. CAPACITORS - VALUES IN μ F UNLESS OTHERWISE NOTED.
3. INDUCTORS - VALUES IN μ H UNLESS OTHERWISE NOTED.
4. *FACTORY SELECT. TYPICAL VALUE SHOWN.
5. ALL VOLTAGES ARE DC UNLESS OTHERWISE NOTED.

IC NO	TYPE
1	MFC6070
2, 3	SN7400

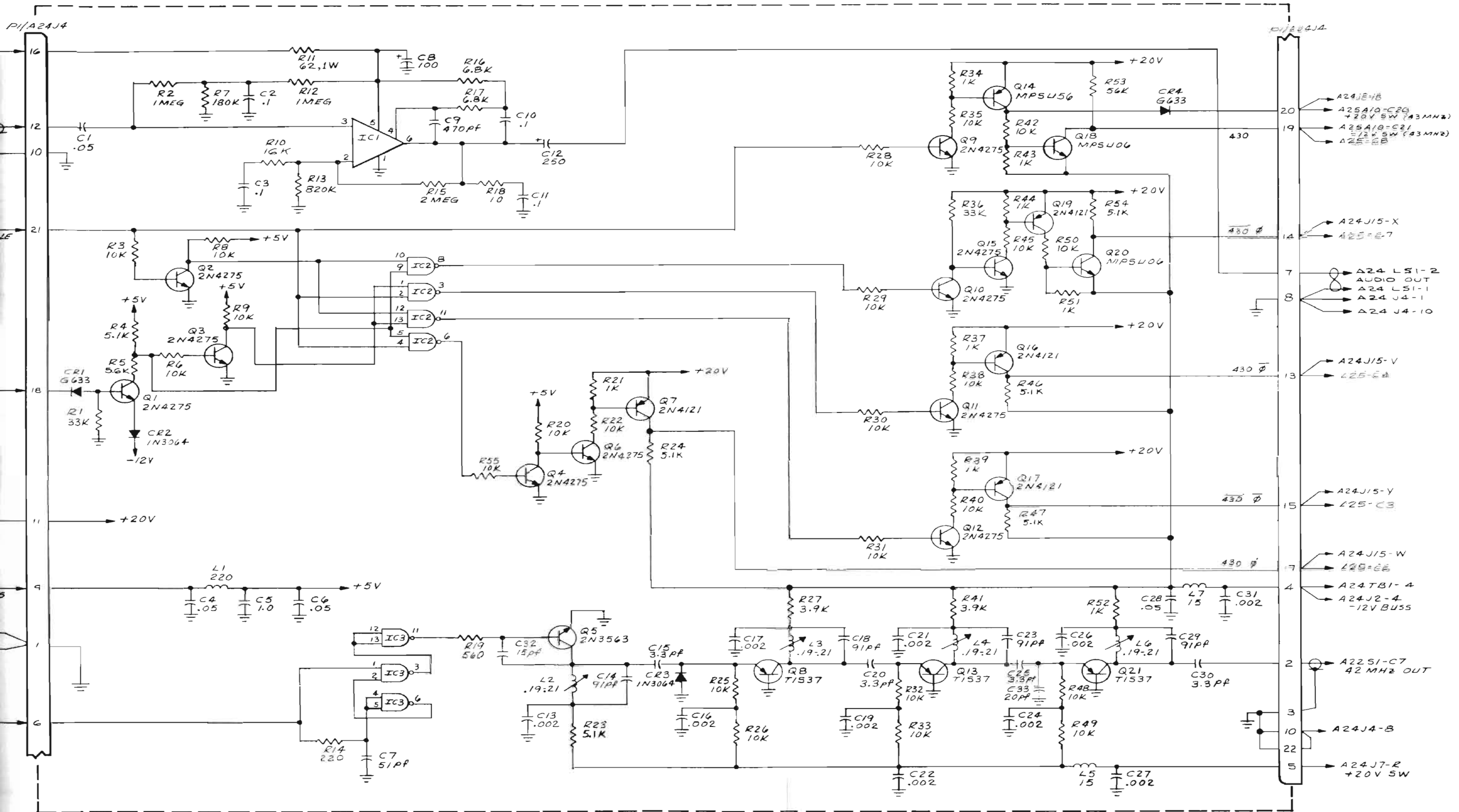

- NOTE:
1. RESISTORS - 1/4W, 5% VALUES IN OHMS UNLESS OTHERWISE NOTED.
 2. CAPACITORS - VALUES IN μ F UNLESS OTHERWISE NOTED.
 3. INDUCTORS - VALUES IN μ H UNLESS OTHERWISE NOTED.
 4. *FACTORY SELECT. TYPICAL VALUE SHOWN.
 5. ALL VOLTAGES ARE DC UNLESS OTHERWISE NOTED.

IC NO	TYPE
1	MFC6070
2,3	SN7400

Figure 6-15. 42 MHz Filter, Audio Amplifier, Mixer and IF Switching. A16

PROGRAMMABLE PHASE LOCK LOOP AND AMPLIFIER. A17

CKT. REF.	DESCRIPTION	CE STOCK NO.	MFR.	MFR. NO.
A17	P. C. Board Assy, Programmable Phase Lock Loop & Ampl	7001-0217	Cushman	
	P. C. Board	1780-0452	Cushman	
	CAPACITORS			
C1	Mica, 220pF, $\pm 5\%$, 500V	1002-0029	Elmenco	DM15-F-221J
C2	Cer, .002 μ F, $\pm 20\%$, 500V	1005-0003	Erie	831-596-Z5U-202M
C3	Cer, 1000pF, $\pm 10\%$, 100V	1005-0081	Erie	8121-100-W5R-102K
C4	Tant, 10 μ F, +50 -20%, 35V	1011-0006	ITT	Tag 10/35-20
C5	Cer, .01 μ F, $\pm 20\%$, 25V	1005-0013	Erie	5835-512-Y5U-103Z
C6	Cer, 5.0pF, $\pm .25$ pF, 500V	1005-0112	Erie	301-000-COHO-509C
C7	Cer, .002 μ F, $\pm 20\%$, 500V	1005-0003	Erie	831-596-Z5U-202M
C8	Cer, .47pF, $\pm 10\%$, 50V	1005-0092	Cap Sales	CK06BX474K
C9	Poly, .0056 μ F, $\pm 10\%$, 100V	1008-0022	Sprague	225P56291WA3
C10	Mica, 36pF, $\pm 5\%$, 500V	1004-0007	Cornl Dubilier	CD6ED360J
C11	Tant, 10 μ F, +50 -20%, 35V	1011-0006	ITT	Tag 10/35-20
C12	Cer, .05 μ F, +80 -20%, 25V	1005-0014	Erie	5855-505-Y5U-503Z
C13	Cer, .002 μ F, $\pm 20\%$, 500V	1005-0003	Erie	831-596-Z5U-202M
C14	Cer, .002 μ F, $\pm 20\%$, 500V	1005-0003	Erie	831-596-Z5U-202M
C15	Cer, .002 μ F, $\pm 20\%$, 500V	1005-0003	Erie	831-596-Z5U-202M
C16	Var. Cer, 5.5-18pF	1001-0008	Erie	538-002A-5.5-18
C17	Cer, .1 μ F, $\pm 10\%$, 100V	1005-0064	Aerovox	CK06BX104K
C18	Cer, .002 μ F, $\pm 20\%$, 500V	1005-0003	Erie	831-596-Z5U-202M
C19	Cer, .002 μ F, $\pm 20\%$, 500V	1005-0003	Erie	831-596-Z5U-202M
C20	Cer, .002 μ F, $\pm 20\%$, 500V	1005-0003	Erie	831-596-Z5U-202M
C21	Cer, .002 μ F, $\pm 20\%$, 500V	1005-0003	Erie	831-596-Z5U-202M
C22	Cer, .002 μ F, $\pm 20\%$, 500V	1005-0003	Erie	831-596-Z5U-202M
C23	Not used			
C24	Cer, .002 μ F, $\pm 20\%$, 500V	1005-0003	Erie	831-596-Z5U-202M
C25	Cer, .002 μ F, $\pm 20\%$, 500V	1005-0003	Erie	831-596-Z5U-202M
C26	Cer, .002 μ F, $\pm 20\%$, 500V	1005-0003	Erie	831-596-Z5U-202M
C27	Mica, 150pF, $\pm 5\%$, 500V	1002-0021	Elmenco	DM15-F-151J
C28	Elect, 1.5 μ F, $\pm 10\%$, 35V	1013-0001	Sprague	150D155X9035B2
C29	Cer, .002 μ F, $\pm 20\%$, 500V	1005-0003	Erie	831-596-Z5U-202M
C30	Cer, .01 μ F, +80 -20%, 25V	1005-0013	Erie	5835-512-Y5U-103Z
C31	Not Used			
C32	Mica, 22pF, $\pm 5\%$, 500V	1002-0023	Elmenco	DM15-C-220J
C33	Cer, .002 μ F, $\pm 20\%$, 500V	1005-0003	Erie	831-596-Z5U-202M
C34	Cer, .002 μ F, $\pm 20\%$, 500V	1005-0003	Erie	831-596-Z5U-202M
C35	Cer, .002 μ F, $\pm 20\%$, 500V	1005-0003	Erie	831-596-Z5U-202M
C36	Tant, 10 μ F, +50 -20%, 35V	1011-0006	ITT	Tag 10/35-20
C37	Mica, 91pF, $\pm 5\%$, 500V	1002-0027	Elmenco	DM15-F-910J
C38	Mica, 91pF, $\pm 5\%$, 500V	1002-0027	Elmenco	DM15-F-910J
C39	Cer, .01 μ F, +80 -20%, 25V	1005-0013	Erie	5835-512-Y5U-103Z
C40	Cer, .01 μ F, +80 -20%, 25V	1005-0013	Erie	5835-512-Y5U-103Z
C41	Cer, .01 μ F, +80 -20%, 25V	1005-0013	Erie	5835-512-Y5U-103Z
C42	Cer, .01 μ F, +80 -20%, 25V	1005-0013	Erie	5835-512-Y5U-103Z
C43	Cer, .002 μ F, $\pm 20\%$, 500V	1005-0003	Erie	831-596-Z5U-202M
	COILS			
L1	Choke, Molded, 1 μ H, $\pm 10\%$	1585-0027	Delevan	1537-12
L2	Choke, Molded, 1 μ H, $\pm 10\%$	1585-0027	Delevan	1537-12
L3	Choke, Molded, 1 μ H, $\pm 10\%$	1585-0027	Delevan	1537-12
L4	Variable, 5 1/2 turns	1596-0064-03	Cushman	
L5	Variable, 2 1/2 turns	1596-0064-04	Cushman	

PROGRAMMABLE PHASE LOCK LOOP AND AMPLIFIER (cont). A17

CKT. REF.	DESCRIPTION	CE STOCK NO.	MFR.	MFR. NO.
L6	Choke, Molded, 1 μ H, \pm 10%	1585-0027	Delevan	1537-12
L7	Choke, 2 1/2 turns	1586-0003		VK20020/4B
L8	Variable, 1 turn	1596-0064-05	Cushman	
L9	Choke, Molded, 1 μ H, \pm 10%	1585-0027	Delevan	1537-12
L10	Choke, .22 μ H, \pm 10%	1585-0039	Delevan	1537-02
L11	Choke, 2 1/2 turns	1586-0003		VK20020/4B
L12	Choke, Molded, 1 μ H, \pm 10%	1585-0027	Delevan	1537-12
L13	Choke, .68 μ H, \pm 10%	1585-0024	Delevan	1537-08
L14	Choke, 3.3 μ H, \pm 10%	1585-0037	Delevan	1537-24
L15	Choke, .68 μ H, \pm 10%	1585-0024	Delevan	1537-08
L16	Choke, Molded, 10 μ H, \pm 10%	1585-0016	Delevan	1537-36
DIODES				
CR1	Si, Diodes, 1N3064	1281-0013	Teledyne	1N3064
CR2	Si, Diodes, 1N3064	1281-0013	Teledyne	1N3064
CR3	Si, Diodes, 1N3064	1281-0013	Teledyne	1N3064
CR4	Si, Diodes, 1N3064	1281-0013	Teledyne	1N3064
CR5	Si, Diodes, 1N3064	1281-0013	Teledyne	1N3064
CR6	Si, Diodes, 1N3064	1281-0013	Teledyne	1N3064
CR7	Si, Diodes, 1N3064	1281-0013	Teledyne	1N3064
CR8	Si, Diodes, 1N3064	1281-0013	Teledyne	1N3064
CR9	Si, Pin Switching	1281-0050	Motorola	MPN3401
CR10	Si, Pin Switching	1281-0050	Motorola	MPN3401
CR11	Si, Dual Voltage Varicap	1281-0058	Motorola	MV104
CR12	Si, Pin Switching	1281-0050	Motorola	MPN3401
CR13	Si, Diodes, 1N3064	1281-0013	Teledyne	1N3064
CR14	Diode, Ge, G633	1282-0005	ITT	G633
CR15	Si, Pin Switching	1281-0050	Motorola	MPN3401
CR16	Diode, HP5982-2800	1283-0001	H. P.	HP5982-2800
CR17	Diode, HP5982-2800	1283-0001	H. P.	HP5982-2800
CR18	Diode, HP5982-2800	1283-0001	H. P.	HP5982-2800
CR19	Diode, HP5982-2800	1283-0001	H. P.	HP5982-2800
CR20	Zener, 4.3V	1281-0025	I. R.	1N4731A
CR21	Zener, 4.3V	1281-0025	I. R.	1N4731A
INTEGRATED CIRCUITS				
IC1	I. C., Op-Ampl, LM301A	2025-0032	National	LM301A
RESISTORS				
R1	Comp, 10k, \pm 5%, 1/4W	1066-1035	Allen-Bradley	CB1035
R2	Comp, 10k, \pm 5%, 1/4W	1066-1035	Allen-Bradley	CB1035
R3	Comp, 4.7k, \pm 5%, 1/4W	1066-4725	Allen-Bradley	CB4725
R4	Comp, 4.7k, \pm 5%, 1/4W	1066-4725	Allen-Bradley	CB4725
R5	Comp, 4.7k, \pm 5%, 1/4W	1066-4725	Allen-Bradley	CB4725
R6	Comp, 100 Ω , \pm 5%, 1/4W	1066-1015	Allen-Bradley	CB1015
R7	Comp, 330 Ω , \pm 5%, 1/4W	1066-3315	Allen-Bradley	CB3315
R8	Comp, 6.8k, \pm 5%, 1/4W	1066-6825	Allen-Bradley	CB6825
R9	Comp, 8.2k, \pm 5%, 1/4W	1066-8225	Allen-Bradley	CB8225
R10	Comp, 100 Ω , \pm 5%, 1/4W	1066-1015	Allen-Bradley	CB1015
R11	Comp, 390 Ω , \pm 5%, 1/4W	1066-3915	Allen-Bradley	CB3915
R12	Comp, 1.5k, \pm 5%, 1/4W	1066-1525	Allen-Bradley	CB1525
R13	Comp, 3.3k, \pm 5%, 1/4W	1066-3325	Allen-Bradley	CB3325
R14	Comp, 33k, \pm 5%, 1/4W	1066-3335	Allen-Bradley	CB3335
R15	Comp, 10k, \pm 5%, 1/4W	1066-1035	Allen-Bradley	CB1035

PROGRAMMABLE PHASE LOCK LOOP AND AMPLIFIER (cont). A17

CKT. REF.	DESCRIPTION	CE STOCK NO.	MFR.	MFR. NO.
R16	Comp, 82Ω, ±5%, 1/4W	1066-8205	Allen-Bradley	CB8205
R17	Comp, 27Ω, ±5%, 1/4W	1066-2705	Allen-Bradley	CB2705
R18	Comp, 220Ω, ±5%, 1/4W	1066-2215	Allen-Bradley	CB2215
R19	Comp, 150Ω, ±5%, 1/4W	1066-1515	Allen-Bradley	CB1515
R20	Comp, 620Ω, ±5%, 1/4W	1066-6215	Allen-Bradley	CB6215
R21	Comp, 470Ω, ±5%, 1/4W	1066-4715	Allen-Bradley	CB4715
R22	Comp, 51Ω, ±5%, 1/4W	1066-5105	Allen-Bradley	CB5105
R23	Comp, 18k, ±5%, 1/4W	1066-1835	Allen-Bradley	CB1835
R24	Comp, 10k, ±5%, 1/4W	1066-1035	Allen-Bradley	CB1035
R25	Comp, 82Ω, ±5%, 1/4W	1066-8205	Allen-Bradley	CB8205
R26	Comp, 130Ω, ±5%, 1/4W	1066-1315	Allen-Bradley	CB1315
R27	Comp, 1.8k, ±5%, 1/4W	1066-1825	Allen-Bradley	CB1825
R28	Comp, 270Ω, ±5%, 1/4W	1066-2715	Allen-Bradley	CB2715
R29	Comp, 1.8k, ±5%, 1/4W	1066-1825	Allen-Bradley	CB1825
R30	Comp, 620Ω, ±5%, 1/4W	1066-6215	Allen-Bradley	CB6215
R31	Comp, 10k, ±5%, 1/4W	1066-1035	Allen-Bradley	CB1035
R32	Comp, 10k, ±5%, 1/4W	1066-1035	Allen-Bradley	CB1035
R33	Comp, 10k, ±5%, 1/4W	1066-1035	Allen-Bradley	CB1035
R34	Comp, 18k, ±5%, 1/4W	1066-1835	Allen-Bradley	CB1835
R35	Comp, 18k, ±5%, 1/4W	1066-1835	Allen-Bradley	CB1835
R36	Comp, 2.2k, ±5%, 1/4W	1066-2225	Allen-Bradley	CB2225
R37	Comp, 22k, ±5%, 1/4W	1066-2235	Allen-Bradley	CB2235
R38	Comp, 2.2k, ±5%, 1/4W	1066-2225	Allen-Bradley	CB2225
R39	Comp, 22k, ±5%, 1/4W	1066-2235	Allen-Bradley	CB2235
R40	Comp, 56k, ±5%, 1/4W	1066-5635	Allen-Bradley	CB5635
R41	Comp, 56k, ±5%, 1/4W	1066-5635	Allen-Bradley	CB5635
R42	Comp, 100k, ±5%, 1/4W	1066-1045	Allen-Bradley	CB1045
R43	Comp, 100k, ±5%, 1/4W	1066-1045	Allen-Bradley	CB1045
R44	Comp, 10k, ±5%, 1/4W	1066-1035	Allen-Bradley	CB1035
R45	Comp, 1k, ±5%, 1/4W	1066-1025	Allen-Bradley	CB1025
R46	Comp, 33k, ±5%, 1/4W	1066-3335	Allen-Bradley	CB3335
R47	Comp, 10k, ±5%, 1/4W	1066-1035	Allen-Bradley	CB1035
R48	Comp, 22k, ±5%, 1/4W	1066-2235	Allen-Bradley	CB2235
R49	Comp, 100k, ±5%, 1/4W	1066-1045	Allen-Bradley	CB1045
R50	Comp, 18k, ±5%, 1/4W	1066-1835	Allen-Bradley	CB1835
R51	Comp, 100k, ±5%, 1/4W	1066-1045	Allen-Bradley	CB1045
R52	Comp, 5.1k, ±5%, 1/4W	1066-5125	Allen-Bradley	CB5125
R53	Comp, 1.5k, ±5%, 1/4W	1066-1525	Allen-Bradley	CB1525
R54	Pot, 5k, ±10%, 3/4W	1215-0012	Helitrim	89 WR
R55	Comp, 15k, ±5%, 1/4W	1066-1535	Allen-Bradley	CB1535
R56	Comp, 15k, ±5%, 1/4W	1066-1535	Allen-Bradley	CB1535
R57	Comp, 39k, ±5%, 1/4W	1066-3935	Allen-Bradley	CB3935
R58	Pot, 10k, ±10%, 3/4W	1215-0014	Helitrim	89 WR
R59	Comp, 330k, ±5%, 1/4W	1066-3345	Allen-Bradley	CB3345
R60	Comp, 10k, ±5%, 1/4W	1066-1035	Allen-Bradley	CB1035
R61	Comp, 1.8k, ±5%, 1/4W	1066-1825	Allen-Bradley	CB1825
R62	Comp, 100Ω, ±5%, 1/4W	1066-1015	Allen-Bradley	CB1015
R63	Comp, 1.5k, ±5%, 1/4W	1066-1525	Allen-Bradley	CB1525
R64	Comp, 10k, ±5%, 1/4W	1066-1035	Allen-Bradley	CB1035
R65	Comp, 10k, ±5%, 1/4W	1066-1035	Allen-Bradley	CB1035
R66	Comp, 39Ω, ±5%, 1/4W	1066-3905	Allen-Bradley	CB3905
R67	Not Used			
R68	Not Used			
R69	Comp, 10k, ±5%, 1/4W	1066-1035	Allen-Bradley	CB1035
R70	Comp, FSV, ±5%, 1/4W	1066-xxxx	Allen-Bradley	CBxxxx

PROGRAMMABLE PHASE LOCK LOOP AND AMPLIFIER (cont). A17

CKT. REF.	DESCRIPTION	CE STOCK NO.	MFR.	MFR. NO.
	TRANSFORMER			
T1	Not Used			
T2	Toroid, Trifilar Coil Assy	1579-0017	Cushman	
T3	Toroid, Trifilar Coil Assy	1579-0017	Cushman	
T4	Toroid, Trifilar Coil Assy	1579-0017	Cushman	
	TRANSISTORS			
Q1	Si, NPN, 2N4275	1272-0016	Fairchild	2N4275
Q2	Si, NPN, 2N4275	1272-0016	Fairchild	2N4275
Q3	Si, NPN, 2N4275	1272-0016	Fairchild	2N4275
Q4	Si, NPN, 2N4275	1272-0016	Fairchild	2N4275
Q5	Si, NPN, 2N4275	1272-0016	Fairchild	2N4275
Q6	Si, PNP, 2N4121	1272-0023	Fairchild	2N4121
Q7	Si, PNP, 2N4121	1272-0023	Fairchild	2N4121
Q8	Si, NPN, 2N5179	1272-0067	RCA	2N5179
Q9	Si, NPN, MPS-U06	1272-0053	Motorola	MPS-U06
Q10	Si, PNP, 2N4121	1272-0023	Fairchild	2N4121
Q11	Si, PNP, 2N4121	1272-0023	Fairchild	2N4121
Q12	Si, PNP, 2N4121	1272-0023	Fairchild	2N4121
Q13	Si, PNP, 2N3906	1272-0037	Motorola	2N3906
Q14	Not Used			
Q15	Si, NPN, 2N5179	1272-0067	RCA	2N5179
Q16	Si, NPN, 2N5179	1272-0067	RCA	2N5179
Q17	Si, NPN, 2N3563	1272-0022	Fairchild	2N3563
Q18	Si, NPN, 2N3563	1272-0022	Fairchild	2N3563
Q19	Not Used			
Q20	Not Used			
Q21	Not Used			
Q22	Not Used			
Q23	Si, NPN, 2N4275	1272-0016	Fairchild	2N4275
Q24	Si, NPN, 2N4275	1272-0016	Fairchild	2N4275

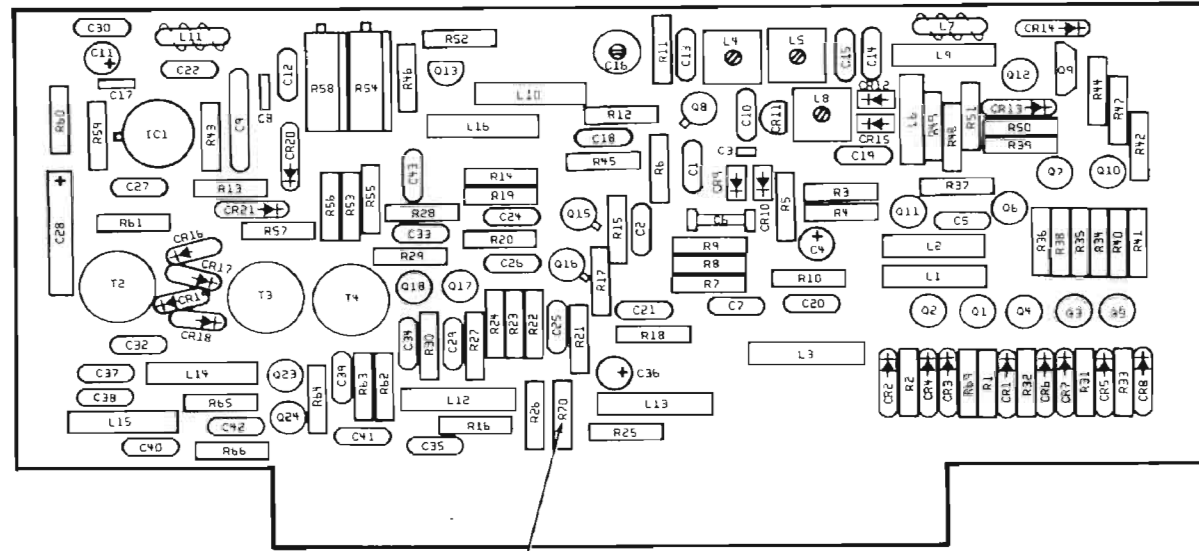

1. INSTALLED IN SOME UNITS IN FINAL TEST.

NOTES:

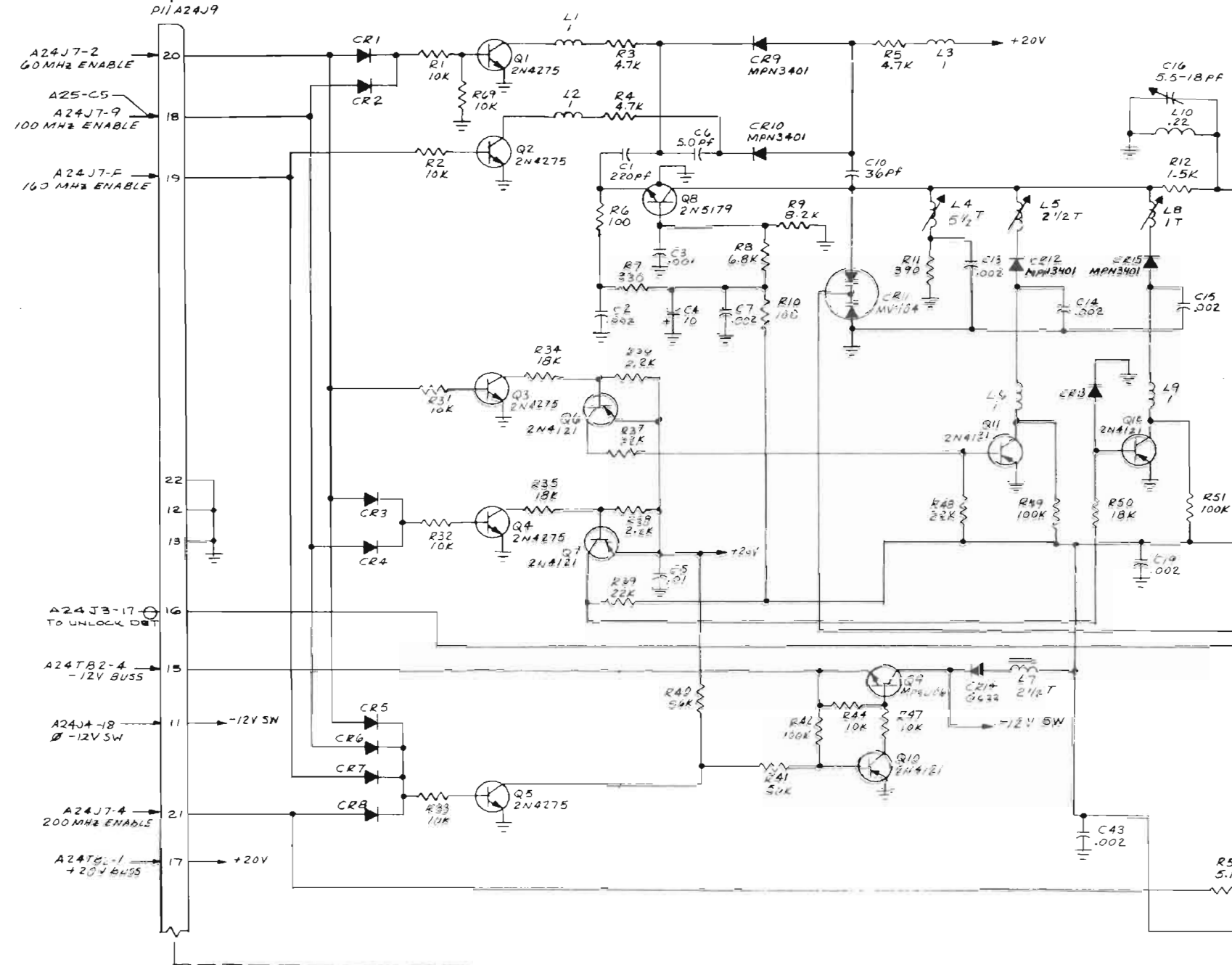

NOTE:

1. RESISTORS - 1/4W, 5% VALUES UNLESS OTHERWISE NOTED.
2. CAPACITORS - VALUES IN μ F UNLESS OTHERWISE NOTED.
3. INDUCTORS - VALUES IN μ H UNLESS OTHERWISE NOTED.
4. FACTORY SELECTIONS - TYPICAL VALUE SHOWN.
5. ALL VOLTAGES ARE DC UNLESS OTHERWISE NOTED.
6. ALL DIODES ARE IN3064 UNLESS OTHERWISE NOTED.

7. INSTALLED IN SOME UNITS IN FINAL TEST.

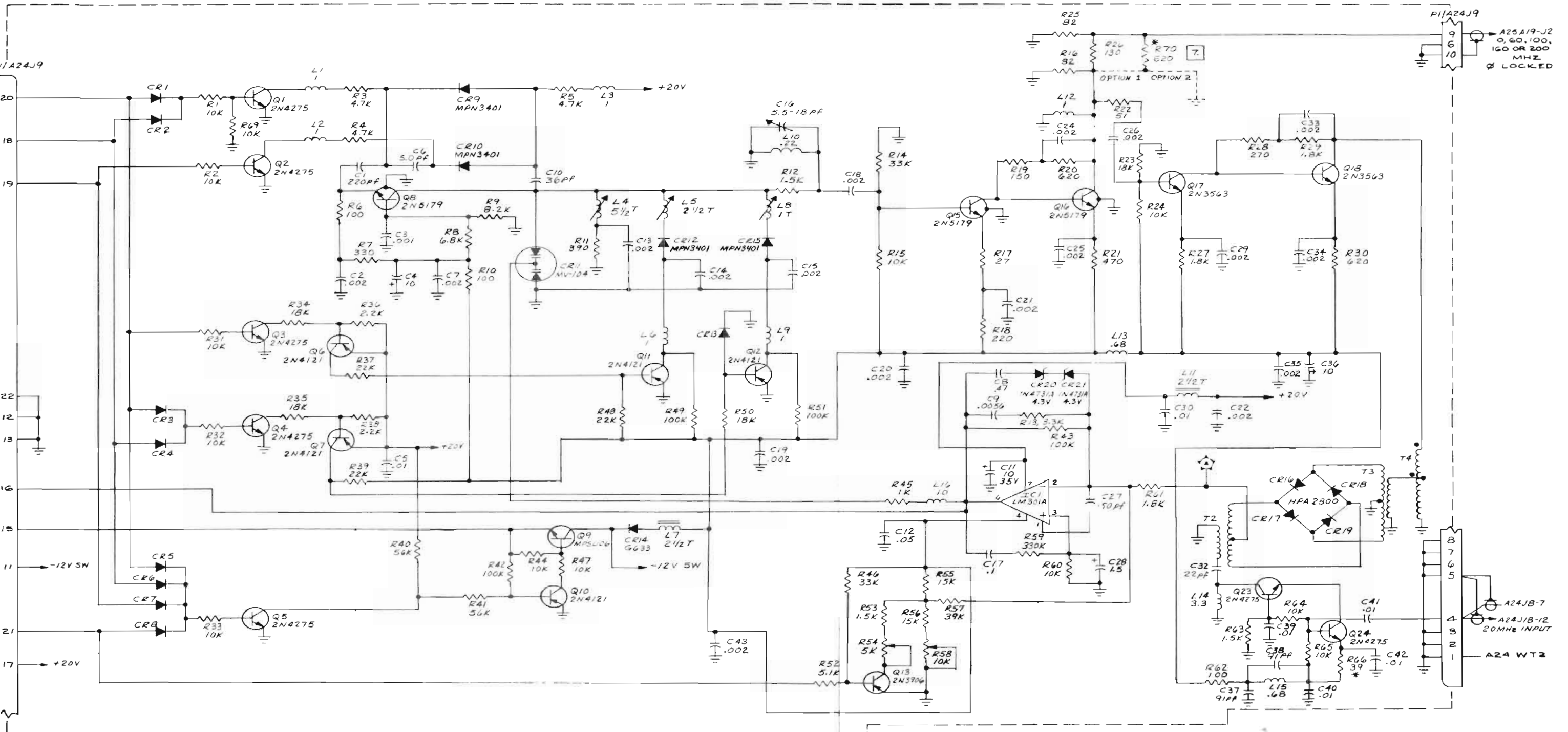

NOTE:
 1. RESISTORS - 1/4W, 5% VALUES IN OHMS UNLESS OTHERWISE NOTED.
 2. CAPACITORS - VALUES IN μ F UNLESS OTHERWISE NOTED.
 3. INDUCTORS - VALUES IN μ H UNLESS OTHERWISE NOTED.
 4. *FACTORY SELECT. TYPICAL VALUE SHOWN.
 5. ALL VOLTAGES ARE DC UNLESS OTHERWISE NOTED.
 6. ALL DIODES ARE IN3069 UNLESS OTHERWISE NOTED.

NOT USED:
 C 23, 31
 Q 14, 19, 20, 21, 22
 R 17, 68
 T 1

Figure 6-16. Programmable Phase Lock Loop and Amplifier. A17
 6-77/6-78

10 MHz MODULATOR, A18

CKT. REF.	DESCRIPTION	CE STOCK NO.	MFR.	MFR. NO.
A18	PCB Assy, 10 MHz Modulator PC Board	7001-0443 1780-0449	Cushman Cushman	
	CAPACITORS			
C1	Cap, .027 μ F, 10%, 100V	1008-0032	Sprague	225P27391
C2	Cap, 2.2 μ F, 10%, 35V	1011-0001	Dickson	D2R2GSB35K
C3	Cap, .022 μ F, 1%, 100V	1008-0082	IMB	XA2B223F
C4	Cap, 330PF, 5%, 500V Mica	1002-0032	Elmenco	DM15-F331J
C5	Cap, .1 μ F, 10%, 100V	1008-0031	Sprague	225P10491WA3
C6	Cap, 820PF, 5%, 300V Mica	1002-0039	Elmenco	DM15-F-821J
C7	Cap, .022 μ F, 1%, 100V	1008-0082	IMB	XA2B223F
C8	Not Used			
C9	Cap, 180PF, 5%, 500V Mica	1002-0005	Elmenco	DM15-F-181J
C10	Cap, 22PF, 5%, 500V Mica	1002-0023	Elmenco	DM15-C-220J
C11	Cap, .01 μ F, +80-20%, 25V Disc	1005-0013	Erie	5835-512-Y5U-103Z
C12	Cap, 22PF, 2%, 500V Tub	1005-0007	Erie	301-000-U2J0-220G
C13	Cap, .022 μ F, 1%, 100V	1008-0082	IMB	XA2B223F
C14	Cap, 470PF, 5%, 500V Mica	1002-0035	Elmenco	DM15-F-471J
C15	Cap, 470PF, 5%, 500V Mica	1002-0035	Elmenco	DM15-F-471J
C16	Cap, .05 μ F, +80-20%, 25V Disc	1005-0014	Erie	5855-505-Y5U0-503Z
C17	Cap, 15PF, 5%, 500V Mica	1002-0001	Elmenco	DM15-C-150J
C18	Cap, .1 μ F, 10%, 100V	1008-0031	Sprague	225P10491WA3
C19	Not Used			
C20	Cap, .05 μ F, +80-20%, 25V Disc	1005-0014	Erie	5855-505-Y5U0-503Z
C21	Cap, 390PF, 5%, 500V Mica	1002-0033	Elmenco	DM15-F-391J
C22	Cap, 820PF, 5%, 300V Mica	1002-0039	Elmenco	DM15-F-821J
C23	Cap, 20PF, 5%, 500V Mica	1002-0060	Elmenco	DM15-E-200J
C24	Cap, .05 μ F, +80-20%, 25V Disc	1005-0014	Erie	5855-505-Y5U0-503Z
C25	Cap, .01 μ F, +80-20%, 25V Disc	1005-0013	Erie	5835-512-Y5U-103Z
C26	Not Used			
C27	Cap, .05 μ F, +80-20%, 25V Disc	1005-0014	Erie	5855-505-Y5U0-503Z
C28	Cap, 10 μ F, +50-20%, 35V	1011-0006	ITT	TAG 10/35-20
C29	Cap, 470PF, 5%, 500V Mica	1002-0035	Elmenco	DM15-F-471J
C30	Cap, .05 μ F, +80-20%, 25V Disc	1005-0014	Erie	5855-505-Y5U0-503Z
C31	Cap, .05 μ F, +80-20%, 25V Disc	1005-0014	Erie	5855-505-Y5U0-503Z
C32	Cap, .002 μ F, 20%, 500V Disc	1005-0003	Erie	831-596-Z5U-202M
C33	Cap, 100 μ F, 20%, 20V	1011-0010	Kemet	T362D107M020AS
C34	Cap, .05 μ F, +80-20%, 25V Disc	1005-0014	Erie	5855-505-Y5U0-503Z
C35	Cap, .05 μ F, +80-20%, 25V Disc	1005-0014	Erie	5855-505-Y5U0-503Z
C36	Cap, .01 μ F, +80-20%, 25V Disc	1005-0013	Erie	5835-512-Y5U-103Z
C37	Cap, 430PF, 5%, 500V Mica	1002-0034	Elmenco	DM15-F-431J
C38	Cap, .05 μ F, +80-20%, 25V Disc	1005-0014	Erie	5855-505-Y5U0-503Z
C39	Cap, .0033 μ F, 10%, 100V	1008-0041	Sprague	225P33291WA3
C40	Cap, 470PF, 5%, 500V Mica	1002-0035	Elmenco	DM15-F-471J
C41	Cap, 10 μ F, +50-20%, 35V	1011-0006	ITT	TAG 10/35-20
C42	Cap, 4.7PF, .25PF%, 500V Tub	1005-0015	Erie	301-000-C0H0-479C
C43	Cap, .05 μ F, +80-20%, 25V Disc	1005-0014	Erie	5855-505-Y5U0-503Z
C44	Cap, .05 μ F, +80-20%, 25V Disc	1005-0014	Erie	5855-505-Y5U0-503Z
C45	Cap, .05 μ F, +80-20%, 25V Disc	1005-0014	Erie	5855-505-Y5U0-503Z

10 MHz MODULATOR (cont) A18

CKT. REF.	DESCRIPTION	CE STOCK NO.	MFR.	MFR. NO.
C46	Cap, .05 μ F, +80-20%, 25V Disc	1005-0014	Erie	5855-505-Y5U0-503Z
C47	Cap, .05 μ F, +80-20%, 25V Disc	1005-0014	Erie	5855-505-Y5U0-503Z
C48	Cap, .05 μ F, +80-20%, 25V Disc	1005-0014	Erie	5855-505-Y5U0-503Z
C49	Cap, 10 μ F, +50-20%, 35V	1011-0006	ITT	TAG 10/35-20
C50	Cap, 100 μ F, 20%, 20V	1011-0010	Kemet	T362D107M020AS
DIODES				
CR1	Diode, MV1638	1281-0059	Motorola	MV1638
CR2	Diode, MPN3401	1281-0050	Motorola	MPN3401
CR3	Diode, 1N3064	1281-0013	Teledyne	1N3064
CR4	Diode, 1N3064	1281-0013	Teledyne	1N3064
CR5	Diode, 1N3064	1281-0013	Teledyne	1N3064
CR6	Diode, 1N3064	1281-0013	Teledyne	1N3064
CR7	Diode, HPA2800	1283-0001	HPA	5082-2800
CR8	Diode, 1N3064	1281-0013	Teledyne	1N3064
CR9	Diode, HPA2800	1283-0001	HPA	5082-2800
CR10	Diode, 1N3064	1281-0013	Teledyne	1N3064
CR11	Diode, 1N3064	1281-0013	Teledyne	1N3064
INDUCTORS				
L1	Choke, 82 μ H, 5%	1585-0032	Delevan	1537-72
L2	Coil, 3.8 to 7.3 μ H	1596-0025	Delevan	4000-18
L3	Coil, 8 Turn 16 MHz	1596-0111	Cushman	
L4	Coil, 8 Turn 16 MHz	1596-0111	Cushman	
L5	Choke, .56 μ H, 10%	1585-0036	Delevan	1840-07
L6	Coil, 8 Turn 16 MHz	1596-0111	Cushman	
TRANSISTORS				
Q1	Trans, 2N3565	1272-0017	Fairchild	2N3565
Q2	Trans, 2N4391	1272-0042	Teledyne	2N4391
Q3	Trans, 2N4275	1272-0016	Fairchild	2N4275
Q4	Trans, TIS 37	1271-0003	T.I.	TIS37
Q5	Trans, 2N3904	1272-0032	Motorola	2N3904
Q6	Trans, 2N4121	1272-0023	Fairchild	2N4121
Q7	Trans, 2N4275	1272-0016	Fairchild	2N4275
Q8	Trans, 2N3904	1272-0032	Motorola	2N3904
Q9	Trans, 2N3904	1272-0032	Motorola	2N3904
Q10	Trans, 2N3565	1272-0017	Fairchild	2N3565
Q11	Trans, 2N4121	1272-0023	Fairchild	2N4121
Q12	Trans, 2N4121	1272-0023	Fairchild	2N4121
Q13	Trans, 2N3565	1272-0017	Fairchild	2N3565
Q14	Trans, 2N3904	1272-0032	Motorola	2N3904
Q15	Trans, 2N4121	1272-0023	Fairchild	2N4121
RESISTORS				
R1	Res, 18K, 5%, 1/4W Comp	1066-1835	Allen-Bradley	CB1835
R2	Res, 2 Meg, 5%, 1/4W Comp	1066-2055	Allen-Bradley	CB2055
R3	Res, 294K, 1%, 1/8W MF	1075-0028	Dale	MF 1/8
R4	Res, 220K, 5%, 1/4W Comp	1066-2245	Allen-Bradley	CB2245
R5	Res, 560 Ohm, 5%, 1/4W Comp	1066-5615	Allen-Bradley	CB5615

10 MHz MODULATOR (cont) A18

CKT. REF.	DESCRIPTION	CE STOCK NO.	MFR.	MFR. NO.
R6	Res, 1.2 Meg, 5%, 1/4W Comp	1066-1255	Allen-Bradley	CB1255
R7	Res, 10K, 1%, 1/8W MF	1075-0009	Dale	MF 1/8
R8	Res, 2.49K, 1%, 1/8W MF	1075-0027	Dale	MF 1/8
R9	Res, 137 Ohm, 1%, 1/8W MF	1075-0026	Dale	MF 1/8
R10	Res, 10K, 1%, 1/8W MF	1075-0009	Dale	MF 1/8
R11	Res, 5.6K, 5%, 1/4W Comp	1066-5625	Allen-Bradley	CB5625
R12	Res, 2.2K, 5%, 1/4W Comp	1066-2225	Allen-Bradley	CB2225
R13	Res, 10K, 5%, 1/4W Comp	1066-1035	Allen-Bradley	CB1035
R14	Res, 1 Meg, 5%, 1/4W Comp	1066-1055	Allen-Bradley	CB1055
R15	Res, 10K, 5%, 1/4W Comp	1066-1035	Allen-Bradley	CB1035
R16	Res, 8.2K, 5%, 1/4W Comp	1066-8225	Allen-Bradley	CB8225
R17	Res, 8.2K, 5%, 1/4W Comp	1066-8225	Allen-Bradley	CB8225
R18	Res, 10K, 5%, 1/4W Comp	1066-1035	Allen-Bradley	CB1035
R19	Res, 1.8K, 5%, 1/4W Comp	1066-1825	Allen-Bradley	CB1825
R20	Res, 1.2K, 5%, 1/4W Comp	1066-1225	Allen-Bradley	CB1225
R21	Res, 620 Ohm, 5%, 1/4W Comp	1066-6215	Allen-Bradley	CB6215
R22	Res, 8.2K, 5%, 1/4W Comp	1066-8225	Allen-Bradley	CB8225
R23	Res, 10 Ohm, 5%, 1/4W Comp	1066-1005	Allen-Bradley	CB1005
R24	Res, 2.2K, 5%, 1/4W Comp	1066-2225	Allen-Bradley	CB2225
R25	Res, 5.1K, 5%, 1/4W Comp	1066-5125	Allen-Bradley	CB5125
R26	Res, 10 Ohm, 5%, 1/4W Comp	1066-1005	Allen-Bradley	CB1005
R27	Res, 10 Ohm, 5%, 1/4W Comp	1066-1005	Allen-Bradley	CB1005
R28	Res, 120 Ohm, 5%, 1/4W Comp	1066-1215	Allen-Bradley	CB1215
R29	Not Used			
R30	Res, 43 Ohm, 5%, 1/4W Comp	1066-4305	Allen-Bradley	CB4305
R31	Res, 5.6K, 5%, 1/4W Comp	1066-5625	Allen-Bradley	CB5625
R32	Res, 10K, 5%, 1/4W Comp	1066-1035	Allen-Bradley	CB1035
R33	Res, 10K, 5%, 1/4W Comp	1066-1035	Allen-Bradley	CB1035
R34	Res, 33K, 5%, 1/4W Comp	1066-3335	Allen-Bradley	CB3335
R35	Res, 15K, 5%, 1/4W Comp	1066-1535	Allen-Bradley	CB1535
R36	Res, 4.7 Ohm, 5%, 1/4W Comp	1066-0001	Ohmite	OB47G5
R37	Pot, 500 Ohm, 10%, 3/4W	1215-0011	Helitrim	89WR
R38	Res, 10K, 5%, 1/4W Comp	1066-1035	Allen-Bradley	CB1035
R39	Res, 4.7K, 5%, 1/4W Comp	1066-4725	Allen-Bradley	CB4725
R40	Res, 4.7 Ohm, 5%, 1/4W Comp	1066-0001	Ohmite	OB47G5
R41	Pot, 500 Ohm, 10%, 3/4W	1215-0011	Helitrim	89WR
R42	Res, 33K, 5%, 1/4W Comp	1066-3335	Allen-Bradley	CB3335
R43	Res, 10K, 5%, 1/4W Comp	1066-1035	Allen-Bradley	CB1035
R44	Res, 10K, 5%, 1/4W Comp	1066-1035	Allen-Bradley	CB1035
R45	Res, 5.1K, 5%, 1/4W Comp	1066-5125	Allen-Bradley	CB5125
R46	Res, 100 Ohm, 5%, 1/4W Comp	1066-1015	Allen-Bradley	CB1015
R47	Res, 10K, 5%, 1/4W Comp	1066-1035	Allen-Bradley	CB1035
R48	Res, 4.7 Ohm, 5%, 1/4W Comp	1066-0001	Ohmite	OB47G5
R49	Pot, 500 Ohm, 10%, 3/4W	1215-0011	Helitrim	89WR
R50	Res, 1.8K, 5%, 1/4W Comp	1066-1825	Allen-Bradley	CB1825
R51	Res, 1K, 5%, 1/4W Comp	1066-1025	Allen-Bradley	CB1025
R52	Res, 10K, 5%, 1/4W Comp	1066-1035	Allen-Bradley	CB1035
R53	Res, 10K, 5%, 1/4W Comp	1066-1035	Allen-Bradley	CB1035
R54	Res, 18 Ohm, 5%, 1/4W Comp	1066-1805	Allen-Bradley	CB1805
R55	Res, 300 Ohm, 5%, 1/4W Comp	1066-3015	Allen-Bradley	CB3015

10 MHz MODULATOR (cont) A18

CKT. REF.	DESCRIPTION	CE STOCK NO.	MFR.	MFR. NO.
R56	Res, 300 Ohm, 5%, 1/4W Comp	1066-3015	Allen-Bradley	CB3015
R57	Res, 4.7K, 5%, 1/4W Comp	1066-4725	Allen-Bradley	CB4725
R58	Res, 27K, 5%, 1/4W Comp	1066-2735	Allen-Bradley	CB2735
R59	Res, 1K, 5%, 1/4W Comp	1066-1025	Allen-Bradley	CB1025
R60	Res, 3.3K, 5%, 1/4W Comp	1066-3325	Allen-Bradley	CB3325
R61	Res, 4.7 Ohm, 5%, 1/4W Comp	1066-0001	Ohmite	OB47G5
R62	Pot, 500 Ohm, 10%, 3/4W	1215-0011	Helitrim	89WR
R63	Res, 5.6K, 5%, 1/4W Comp	1066-5625	Allen-Bradley	CB5625
R64	Res, 1K, 5%, 1/4W Comp	1066-1025	Allen-Bradley	CB1025
R65	Res, 1K, 5%, 1/4W Comp	1066-1025	Allen-Bradley	CB1025
R66	Res, 22K, 5%, 1/4W Comp	1066-2235	Allen-Bradley	CB2235
R67	Res, 3.3K, 5%, 1/4W Comp	1066-3325	Allen-Bradley	CB3325
R68	Res, 4.7K, 5%, 1/4W Comp	1066-4725	Allen-Bradley	CB4725
R69	Res, 6.2K, 5%, 1/4W Comp	1066-6225	Allen-Bradley	CB6225
R70	Res, 1K, 5%, 1/4W Comp	1066-1025	Allen-Bradley	CB1025
R71	Res, 10K, 5%, 1/4W Comp	1066-1035	Allen-Bradley	CB1035
R72	Res, 100K, 5%, 1/4W Carbon Comp	1066-1045	Allen-Bradley	CB1045
R73	Res, 100K, 5%, 1/4W Carbon Comp	1066-1045	Allen-Bradley	CB1045
R74	Not Used			
R75	Res, 2.2K, 5%, 1/4W Comp	1066-2225	Allen-Bradley	CB2225
R76	Res, 6.2K, 5%, 1/4W Comp	1066-6225	Allen-Bradley	CB6225
R77	Res, 4.7K, 5%, 1/4W Comp	1066-4725	Allen-Bradley	CB4725
R78	Res, 2.4K, 5%, 1/4W Comp	1066-2425	Allen-Bradley	CB2425
R79	Res, 3.3K, 5%, 1/4W Comp	1066-3325	Allen-Bradley	CB3325
INTEGRATED CIRCUITS				
U1	IC, N5558V, Dual Op Amp	2025-0058	Signetics	N5558V
U2	IC, SN72741P	2025-0067	T.I.	SN72741P

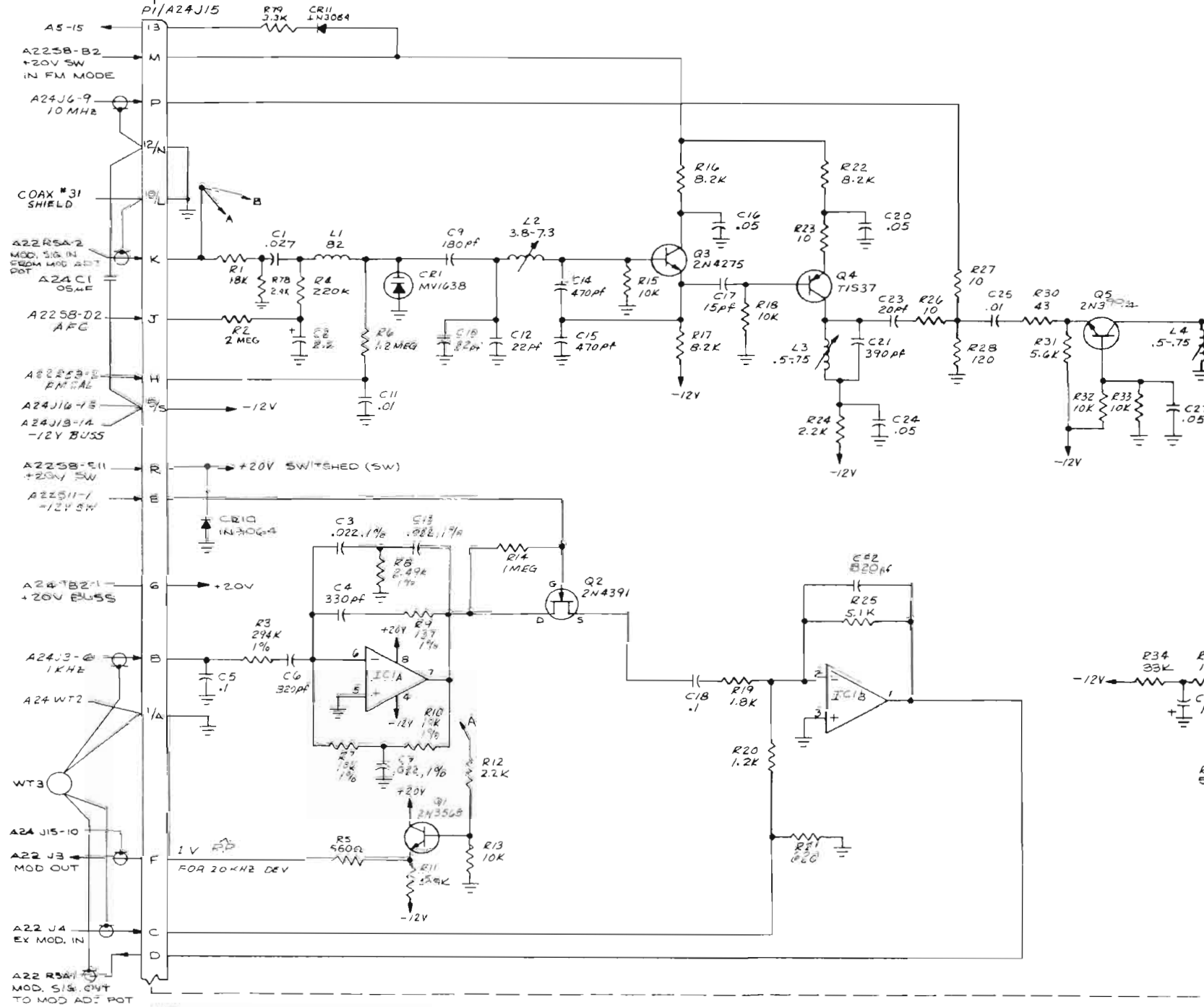
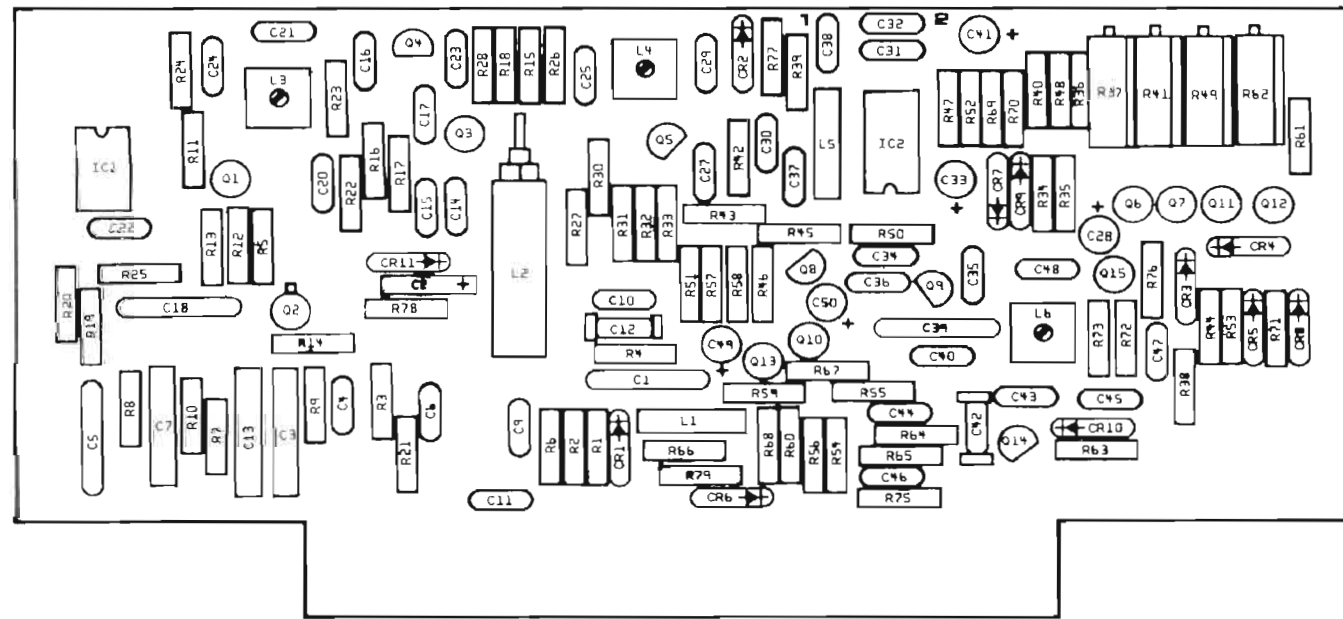

NOTE:
 1. RESISTORS - 1/4W, 5% VALUES UNLESS OTHERWISE NOTED.
 2. CAPACITORS - VALUES IN pF UNLESS OTHERWISE NOTED.
 3. INDUCTORS - VALUES IN μ H UNLESS OTHERWISE NOTED.
 4. FACTORY SREPT. TYPES/VALUES SHOWN.
 5. ALL VOLTAGES ARE DC UNLESS OTHERWISE NOTED.

IC NO	TYPE
1	NE555BY
2	SN721AN

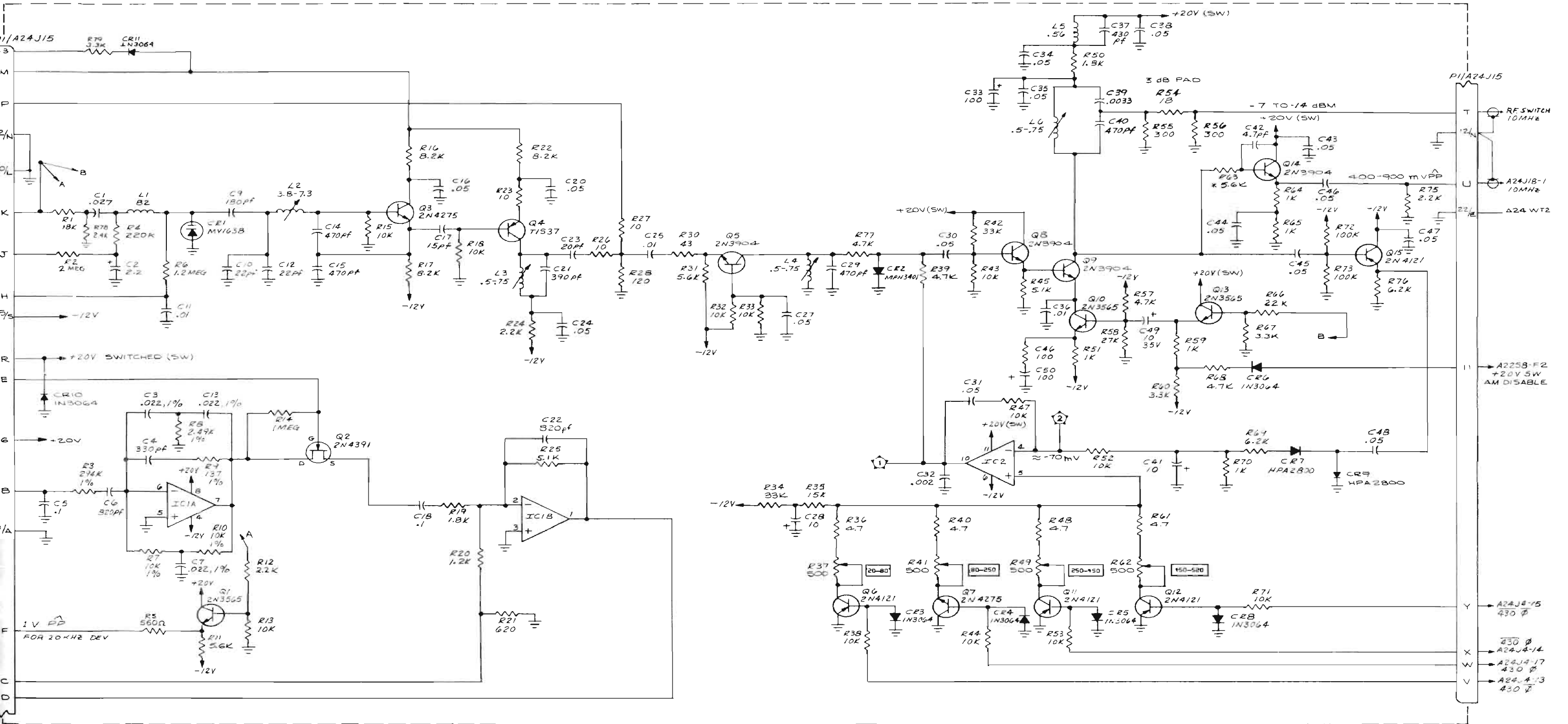

NOTE:
 1. RESISTORS - 1/4W, 5% VALUES IN OHMS UNLESS OTHERWISE NOTED.
 2. CAPACITORS - VALUES IN μ F UNLESS OTHERWISE NOTED.
 3. INDUCTORS - VALUES IN μ H UNLESS OTHERWISE NOTED.
 4. *FACTORY SELECT, TYPICAL VALUE SHOWN.
 5. ALL VOLTAGES ARE DC UNLESS OTHERWISE NOTED.

IC NO	TYPE
1	N555B
2	SN7274IN

Figure 6-17. 10 MHz Modulator. A18

RF MIXERS AND IF AMPLIFIER. A19

CKT. REF.	DESCRIPTION	CE STOCK NO.	MFR.	MFR. NO.
A19	RF Mixers and IF Amplifiers P. C. Board Assy. P. C. Board	7001-0259 1780-0464	Cushman Cushman	
	CAPACITORS			
C1	Cer, .002 μ F, \pm 20%, 500V	1005-0003	Erie	831-596-Z5U-202M
C2	Cer, .002 μ F, \pm 20%, 500V	1005-0003	Erie	831-596-Z5U-202M
C3	Cer, .002 μ F, \pm 20%, 500V	1005-0003	Erie	831-596-Z5U-202M
C4	Cer, .002 μ F, \pm 20%, 500V	1005-0003	Erie	831-596-Z5U-202M
C5	Cer, .002 μ F, \pm 20%, 500V	1005-0003	Erie	831-596-Z5U-202M
C6	Cer, 6.8pF, \pm .25pF, 500V	1005-0006	Erie	301-000-C0H0-689C
C7	Cer, 4.7pF, \pm .25pF, 500V	1005-0015	Erie	301-000-C0H0-479C
C8	Cer, 6.8pF, \pm .25pF, 500V	1005-0006	Erie	301-000-C0H0-689C
C9	Cer, 12pF, \pm 5%, NPO \pm 30, 500V	1005-0076	Erie	301-000-0C0G0-120J
C10	Cer, 10pF, \pm .25pF, 500V	1005-0093	Erie	301-000-C0H0-100C
C11	Cer, .002 μ F, \pm 20%, 500V	1005-0003	Erie	831-596-Z5U-202M
C12	Cer, .01 μ F, \pm 80-20%, 25V	1005-0013	Erie	5835-512-Y5U-103Z
C13	Mica, 820pF, \pm 5%, 300V	1002-0039	Elmenco	DM15-F-821J
C14	Mica, 220pF, \pm 5%, 500V	1002-0029	Elmenco	DM15-F-221J
C15	Mica, 100pF, \pm 5%, 500V	1002-0011	Elmenco	DM15-F-101J
C16	Cer, .002 μ F, \pm 20%, 500V	1005-0003	Erie	831-596-Z5U-202M
C17	Cer, 12pF, \pm 5%, NPO \pm 30%, 500V	1005-0076	Erie	301-000-0C0G0-120J
C18	Cer, 10pF, \pm .25pF, 500V	1005-0093	Erie	301-000-C0H0-100C
C19	Cer, 1000pF, \pm 10%, 100V	1005-0081	Erie	8121-100-W5R-102K
C20	Cer, .002 μ F, \pm 20%, 500V	1005-0003	Erie	831-596-Z5U-202M
C21	Cer, .002 μ F, \pm 20%, 500V	1005-0003	Erie	831-596-Z5U-202M
C22	Cer, .002 μ F, \pm 20%, 500V	1005-0003	Erie	831-596-Z5U-202M
C23	Cer, .002 μ F, \pm 20%, 500V	1005-0003	Erie	831-596-Z5U-202M
C24	Cer, .002 μ F, \pm 20%, 500V	1005-0003	Erie	831-596-Z5U-202M
C25	Cer, .002 μ F, \pm 20%, 500V	1005-0003	Erie	831-596-Z5U-202M
C26	Cer, .002 μ F, \pm 20%, 500V	1005-0003	Erie	831-596-Z5U-202M
C27	Cer, 1000pF, \pm 10%, 100V	1005-0081	Erie	8121-100-W5R-102K
C28	Cer, 10pF, \pm .25pF, 500V	1005-0093	Erie	301-000-C0H0-100C
C29	Cer, 10pF, \pm .25pF, 500V	1005-0093	Erie	301-000-C0H0-100C
C30	Min. Vert. Mt. Cer. Trim, 2-8pF, 350V	1001-0004	Erie	538-002A-2-8-89A
C31	Cer, 10pF, \pm .25pF, \pm .25pF, 500V	1005-0093	Erie	301-000-C0H0-100C
C32	Cer, .002 μ F, \pm 20%, 500V	1005-0003	Erie	831-596-Z5U-202M
C33	Cer, .002 μ F, \pm 20%, 500V	1005-0003	Erie	831-596-Z5U-202M
C34	Cer, Tub, 8.2pF, \pm .25pF, 500V	1005-0043	Erie	301-000-C0H0-829C
C35	Cer, Tub, 5.0pF, \pm .25pF, 500V	1005-0112	Erie	301-000-COHO-509C
C36	Cer, Tub, 5.0pF, \pm .25pF, 500V	1005-0112	Erie	301-000-COHO-509C
C37	Cer, .002 μ F, \pm 20%, 500V	1005-0003	Erie	831-596-Z5U-202M
C38	Cer, Tub, 8.2pF, \pm .25pF, 500V	1005-0043	Erie	301-000-C0H0-829C
C39	Cer, .002 μ F, \pm 20%, 500V	1005-0003	Erie	831-596-Z5U-202M
C40	Cer, .01 μ F, \pm 80-20%, 25V	1005-0013	Erie	5835-512-Y5U-103Z
C41	Cer, Min, 100pF, \pm 10%, 100V	1005-0082	Erie	8121-100-C0G-101K
C42	Cer, Min, 100pF, \pm 10%, 100V	1005-0082	Erie	8121-100-C0G-101K
C43	Cer, 1000pF, \pm 10%, 100V	1005-0081	Erie	8121-100-W5R-102K
C44	Cer, 1000pF, \pm 10%, 100V	1005-0081	Erie	8121-100-W5R-102K
C45	Cer, .002 μ F, \pm 20%, 500V	1005-0003	Erie	831-596-Z5U-202M
C46	Mica, FSV, \pm 5%, 500V	1002-XXXX		
C47	Cer, 1000pF, \pm 10%, 100V	1005-0081	Erie	8121-100-W5R-102K
C48	Cer, .002 μ F, \pm 20%, 500V	1005-0003	Erie	831-596-Z5U-202M
C49	Cer, .002 μ F, \pm 20%, 500V	1005-0003	Erie	831-596-Z5U-202M
C50	Cer, .002 μ F, \pm 20%, 500V	1005-0003	Erie	831-596-Z5U-202M

RF MIXERS AND IF AMPLIFIER (cont). A19

CKT. REF.	DESCRIPTION	CE STOCK NO.	MFR.	MFR. NO.
C51	Cer, .002μF, ±20%, 500V	1005-0003	Erie	831-596-Z5U-202M
C52	Mica, FSV, ±5%, 500V	1002-XXXX		
C53	Cer, .002μF, ±20%, 500V	1005-0003	Erie	831-596-Z5U-202M
C54	Cer, 1000pF, ±10%, 100V	1005-0081	Erie	8121-100-W5R-102K
C55	Cer, .002μF, ±20%, 500V	1005-0003	Erie	831-596-Z5U-202M
C56	Cer, .002μF, ±20%, 500V	1005-0003	Erie	831-596-Z5U-202M
C57	Cer, .002μF, ±20%, 500V	1005-0003	Erie	831-596-Z5U-202M
C58	Feed-thru, 1000pF, +100-0%, 500V	1005-0101	Erie	2404-000-X5U0-102P
C59	Feed-thru, 1000pF, +100-0%, 500V	1005-0101	Erie	2404-000-X5U0-102P
C60	Feed-thru, 1000pF, +100-0%, 500V	1005-0101	Erie	2404-000-X5U0-102P
C61	Feed-thru, 1000pF, +100-0%, 500V	1005-0101	Erie	2404-000-X5U0-102P
C62	Feed-thru, 1000pF, +100-0%, 500V	1005-0101	Erie	2404-000-X5U0-102P
C63	Feed-thru, 1000pF, +100-0%, 500V	1005-0101	Erie	2404-000-X5U0-102P
C64	Feed-thru, 1000pF, +100-0%, 500V	1005-0101	Erie	2404-000-X5U0-102P
C65	Feed-thru, 1000pF, +100-0%, 500V	1005-0101	Erie	2402-000-X5U0-102P
C66	Feed-thru, 1000pF, +100-0%, 500V	1005-0101	Erie	2404-000-X5U0-102P
COILS				
L1	RF Choke, 100μH, ±5%, Molded	1585-0017	Delevan	1537-92
L2	RF Choke, 100μH, ±5%, Molded	1585-0017	Delevan	1537-92
L3	Air Core, 2 1/2 turn	1596-0071	Cushman	
L4	RF Choke, 100μH, ±5%, Molded	1585-0017	Delevan	1537-92
L5	Air Core, 2 1/2 turn	1596-0071	Cushman	
L6	Air Core, 2 1/2 turn	1596-0071	Cushman	
L7	Air Core, 4 turn	1596-0072	Cushman	
L8	Air Core, 2 turn	1596-0070	Cushman	
L9	Air Core, 1 1/2 turn	1596-0069	Cushman	
L10	RF Choke, 220μH, ±5%	1585-0018	Delevan	1537-92
L11	RF Choke, 100μH, ±5%	1585-0017	Delevan	1537-76
L12	RF Choke, 100μH, ±5%	1585-0017	Delevan	1537-76
L13	RF Choke, 100μH, ±5%	1585-0017	Delevan	1537-76
L14	RF Choke, 100μH, ±5%	1585-0017	Delevan	1537-76
L15	Air Core, 3 turn	1596-0076	Cushman	
L16	RF Choke, 100μH, ±5%	1585-0017	Delevan	1537-76
L17	Air Core, 4 turn	1596-0072	Cushman	
L18	Air Core, 4 turn	1596-0072	Cushman	
L19	RF Choke, .22μH, ±20%	1585-0039	Delevan	1537-02
L20	Air Core, 3 turn	1596-0076	Cushman	
L21	Air Core, 2 1/2 turn	1596-0071	Cushman	
L22	RF Choke, 100μH, ±5%	1585-0017	Delevan	1537-76
L23	Air Core, 2 1/2 turn	1596-0071	Cushman	
L24	Air Core, 2 1/2 turn	1596-0071	Cushman	
L25	RF Choke, 100μH, ±5%	1585-0017	Delevan	1537-76
L26	RF Choke, .22μH, ±20%	1585-0039	Delevan	1537-02
L27	RF Choke, .56μH, ±10%	1585-0036	Delevan	1840-07
L28	RF Choke, 2.2μH, ±10%	1585-0013	Delevan	1537-20
L29	RF Choke, 12μH, ±10%	1585-0011	Delevan	1537-38
CONNECTORS				
J1	BNC Jack Bulkhead	2536-0034	Kings	KC-79-143
J2	BNC Jack Bulkhead	2536-0034	Kings	KC-79-143
J3	BNC Jack Bulkhead	2536-0034	Kings	KC-79-143
J4	BNC Jack Bulkhead	2536-0034	Kings	KC-79-143
J5	BNC Jack Bulkhead	2536-0034	Kings	KC-79-143
J6	BNC Jack Bulkhead	2536-0034	Kings	KC-79-143

RF MIXERS AND IF AMPLIFIER (cont). A19

CKT. REF.	DESCRIPTION	CE STOCK NO.	MFR.	MFR. NO.
DIODES				
CR1	Si, Pin Switching	1281-0050	Motorola	MPN-3401
CR2	Si, Pin Switching	1281-0050	Motorola	MPN-3401
CR3	Si, Pin Switching	1281-0050	Motorola	MPN-3401
CR4	Si, Pin Switching	1281-0050	Motorola	MPN-3401
CR5	Si, Pin Switching	1281-0050	Motorola	MPN-3401
CR6	Si, Pin Switching	1281-0050	Motorola	MPN-3401
CR7	Si, Pin, 1SV34	1281-0075	Nippon Elec.	1SV34
CR8	Si, Microwave Mixer	1282-0004	Nucleonic	IN82A
CR9	Si, Microwave Mixer	1282-0004	Nucleonic	IN82A
CR10	Si, Pin Switching	1281-0050	Motorola	MPN-3401
CR11	Si, Pin Switching	1281-0050	Motorola	MPN-3401
CR12	Si, Pin Switching	1281-0050	Motorola	MPN-3401
CR13	Si, Pin Switching	1281-0050	Motorola	MPN-3401
CR14	Si, Pin Switching	1281-0050	Motorola	MPN-3401
CR15	Si, Pin Switching	1281-0050	Motorola	MPN-3401
CR16	Si, Pin Switching	1281-0050	Motorola	MPN-3401
CR17	Si, Pin Switching	1281-0050	Motorola	MPN-3401
CR18	Si, Pin Switching	1281-0050	Motorola	MPN-3401
CR19	Si, Pin Switching	1281-0050	Motorola	MPN-3401
CR20	Si, Pin Switching	1281-0050	Motorola	MPN-3401
CR21	Si, Pin Switching	1281-0050	Motorola	MPN-3401
CR22	Si, Pin Switching	1281-0050	Motorola	MPN-3401
CR23	Si, Pin Switching	1281-0050	Motorola	MPN-3401
CR24	Si, Pin Switching	1281-0050	Motorola	MPN-3401
CR25	Si, Pin Switching	1281-0050	Motorola	MPN-3401
CR26	Si, Pin Switching	1281-0050	Motorola	MPN-3401
CR27	Si, Pin Switching	1281-0050	Motorola	MPN-3401
CR28	Si, Pin Switching	1281-0050	Motorola	MPN-3401
CR29	Si, Pin Switching	1281-0050	Motorola	MPN-3401
CR30	Si, Pin Switching	1281-0050	Motorola	MPN-3401
CR31	Si, Pin Switching	1281-0050	Motorola	MPN-3401
CR32	Si, Pin Switching	1281-0050	Motorola	MPN-3401
CR33	HPA-2900	1283-0003	HPA	HPA-2900
CR34	HPA-2900	1283-0003	HPA	HPA-2900
CR35	Si, Pin Switching	1281-0050	Motorola	MPN-3401
CR36	Si, Pin Switching	1281-0050	Motorola	MPN-3401
CR37	Si, Pin Switching	1281-0050	Motorola	MPN-3401
CR38	Si, Pin Switching	1281-0050	Motorola	MPN-3401
INTEGRATED CIRCUITS				
IC1	26 dB Gain, ATF417	2025-0065	Amperex	ATF417
IC2	High Performance Op-Amp.	2025-0022	T.I.	SN72741N
MIXER				
BM1	Double Balanced	2010-0001	Mini Circuits	MODEL SRA-1
BM2	Double Balanced	2010-0001	Mini Circuits	MOC DL SRA-1
RESISTORS				
R1	Comp, 56 Ω , $\pm 5\%$, 1/4W	1066-5605	Allen-Bradley	CB5605
R2	Comp, 6.8k, $\pm 5\%$, 1/4W	1066-6825	Allen-Bradley	CB6825
R3	Comp, 6.8k, $\pm 5\%$, 1/4W	1066-6825	Allen-Bradley	CB6825
R4	Comp, 150 Ω , $\pm 5\%$, 1/4W	1066-1515	Allen-Bradley	CB1515
R5	Comp, FSV, $\pm 5\%$, 1/4W	1066-XXXX	Allen-Bradley	

RF MIXERS AND IF AMPLIFIER (cont). A19

CKT. REF.	DESCRIPTION	CE STOCK NO.	MFR.	MFR. NO.
R6	Comp, 56Ω, ±5%, 1/4W	1066-5605	Allen-Bradley	CB5605
R7	Comp, 6.8k, ±5%, 1/4W	1066-6825	Allen-Bradley	CB6825
R8	Comp, 6.8k, ±5%, 1/4W	1066-6825	Allen-Bradley	CB6825
R9	Comp, 300Ω, ±5%, 1/4W	1066-3015	Allen-Bradley	CB3015
R10	Comp, 18Ω, ±5%, 1/4W	1066-1805	Allen-Bradley	CB1805
R11	Comp, 300Ω, ±5%, 1/4W	1066-3015	Allen-Bradley	CB3015
R12	Comp, 51Ω, ±5%, 1/4W	1066-5105	Allen-Bradley	CB5105
R13	Comp, 62Ω, ±5%, 1/4W	1066-6205	Allen-Bradley	CB6205
R14	Comp, 3.3k, ±5%, 1/4W	1066-3325	Allen-Bradley	CB3325
R15	Comp, 100Ω, ±5%, 1/4W	1066-1015	Allen-Bradley	CB1015
R16	Comp, 27k, ±5%, 1/4W	1066-2735	Allen-Bradley	CB2735
R17	Pot, 100Ω, ±10%, 3/4W	1215-0010	Helitrim	89WR
R18	Comp, 1M, ±5%, 1/4W	1066-1055	Allen-Bradley	CB1055
R19	Comp, 6.8k, ±5%, 1/4W	1066-6825	Allen-Bradley	CB6825
R20	Comp, 6.8k, ±5%, 1/4W	1066-6825	Allen-Bradley	CB6825
R21	Comp, 6.8K, ±5%, 1/4W	1066-6825	Allen-Bradley	CB6825
R22	Comp, 510Ω, ±5%, 1/4W	1066-5115	Allen-Bradley	CB5115
R23	Comp, 51Ω, ±5%, 1/4W	1066-5105	Allen-Bradley	CB5105
R24	Comp, 6.8k, ±5%, 1/4W	1066-6825	Allen-Bradley	CB6825
R25	Comp, FSV, ±5%, 1/4W	1066-XXXX	Allen-Bradley	
R26	Comp, 100Ω, ±5%, 1/4W	1066-1015	Allen-Bradley	CB1015
R27	Comp, 51Ω, ±5%, 1/4W	1066-5105	Allen-Bradley	CB5105
R28	Comp, 6.8k, ±5%, 1/4W	1066-6825	Allen-Bradley	CB6825
R29	Comp, 6.8k, ±5%, 1/4W	1066-6825	Allen-Bradley	CB6825
R30	Comp, 1k, ±5%, 1/4W	1066-1025	Allen-Bradley	CB1025
R31	Comp, 2.4k, ±5%, 1/4W	1066-2425	Allen-Bradley	CB2425
R32	Comp, FSV, ±5%, 1/4W	1066-XXXX		
R33	Comp, 390Ω, ±5%, 1/4W	1066-3915	Allen-Bradley	CB3915
R34	Comp, 300Ω, ±5%, 1/4W	1066-3015	Allen-Bradley	CB3015
R35	Comp, 18Ω, ±5%, 1/4W	1066-1805	Allen-Bradley	CB1805
R36	Comp, 51Ω, ±5%, 1/4W	1066-5105	Allen-Bradley	CB5105
R37	Comp, 300Ω, ±5%, 1/4W	1066-3015	Allen-Bradley	CB3015
R38	Comp, 6.8k, ±5%, 1/4W	1066-6825	Allen-Bradley	CB6825
R39	Comp, 6.8k, ±5%, 1/4W	1066-6825	Allen-Bradley	CB6825
R40	Comp, 5.1k, ±5%, 1/4W	1066-5125	Allen-Bradley	CB5125
R41	Comp, 6.8k, ±5%, 1/4W	1066-6825	Allen-Bradley	CB6825
R42	Comp, 1k, ±5%, 1/4W	1066-1025	Allen-Bradley	CB1025
R43	Comp, 10k, ±5%, 1/4W	1066-1035	Allen-Bradley	CB1035
R44	Comp, 120Ω, ±5%, 1/4W	1066-1215	Allen-Bradley	CB1215
R45	Comp, 75Ω, ±5%, 1/4W	1066-7505	Allen-Bradley	CB7505
R46	Comp, 75Ω, ±5%, 1/4W	1066-7505	Allen-Bradley	CB7505
R47	Comp, 10k, ±5%, 1/4W	1066-1035	Allen-Bradley	CB1035
R48	Comp, 910Ω, ±5%, 1/4W	1066-9115	Allen-Bradley	CB9115
R49	Comp, 5.1k, ±5%, 1/4W	1066-5125	Allen-Bradley	CB5125
R50	Comp, 10k, ±5%, 1/4W	1066-1035	Allen-Bradley	CB1035
R51	Comp, 5.1k, ±5%, 1/4W	1066-5125	Allen-Bradley	CB5125
R52	Comp, 330Ω, ±5%, 1/4W	1066-3315	Allen-Bradley	CB3315
R53	Comp, 1k, ±5%, 1/4W	1066-1025	Allen-Bradley	CB1025
R54	Comp, 10k, ±5%, 1/4W	1066-1035	Allen-Bradley	CB1035
R55	Comp, 1k, ±5%, 1/4W	1066-1025	Allen-Bradley	CB1025
R56	Comp, 1k, ±5%, 1/4W	1066-1025	Allen-Bradley	CB1025
R57	Comp, 24Ω, ±5%, 1/4W	1066-2405	Allen-Bradley	CB2405
R58	Comp, 220Ω, ±5%, 1/4W	1066-2215	Allen-Bradley	CB2215
R59	Comp, 220Ω, ±5%, 1/4W	1066-2215	Allen-Bradley	CB2215
R60	Comp, 4.7k, ±5%, 1/4W	1066-4725	Allen-Bradley	CB4725

RF MIXERS AND IF AMPLIFIER (cont). A19

CKT. REF.	DESCRIPTION	CE STOCK NO.	MFR.	MFR. NO.
R61	Comp, 2.4k, $\pm 5\%$, 1/4W	1066-2425	Allen-Bradley	CB2425
R62	Comp, 4.3k, $\pm 5\%$, 1/4W	1066-4325	Allen-Bradley	CB4325
R63	Comp, 91 Ω , $\pm 5\%$, 1/4W	1066-9105	Allen-Bradley	CB9105
R64	Comp, 82 Ω , $\pm 5\%$, 1/4W	1066-8205	Allen-Bradley	CB8205
R65	Comp, 91 Ω , $\pm 5\%$, 1/4W	1066-9105	Allen-Bradley	CB9105
R66	Comp, 6.8k, $\pm 5\%$, 1/4W	1066-6825	Allen-Bradley	CB6825
R67	Comp, 20k, $\pm 5\%$, 1/4W	1066-2035	Allen-Bradley	CB2035
R68	Comp, 200 Ω , $\pm 5\%$, 1/8W	1065-2015	Allen-Bradley	BB2015
R69	Comp, FSV, $\pm 5\%$, 1/4W	1066-XXXX		
R70	Comp, 1k, $\pm 5\%$, 1/4W	1066-1025	Allen-Bradley	CB1025
R71	Comp, 1k, $\pm 5\%$, 1/8W	1065-1025	Allen-Bradley	BB1025
R72	Comp, 750 Ω , $\pm 5\%$, 1/4W	1066-7515	Allen-Bradley	CB7515
R73	Not Used			
R74	Comp, 6.8k, $\pm 5\%$, 1/4W	1066-6825	Allen-Bradley	CB6825
R75	Comp, 20k, $\pm 5\%$, 1/4W	1066-2035	Allen-Bradley	CB2035
R76	Comp, 200 Ω , $\pm 5\%$, 1/8W	1065-2015	Allen-Bradley	BB2015
R77	Comp, FSV, $\pm 5\%$, 1/4W	1066-XXXX		
R78	Comp, 1k, $\pm 5\%$, 1/4W	1066-1025	Allen-Bradley	CB1025
R79	Comp, 1k, $\pm 5\%$, 1/8W	1065-1025	Allen-Bradley	BB1025
R80	Comp, 510 Ω , $\pm 5\%$, 1/4W	1066-5115	Allen-Bradley	CB5115
R81	Comp, 2.7k, $\pm 5\%$, 1/4W	1066-2725	Allen-Bradley	CB2725
R82	Comp, 68 Ω , $\pm 5\%$, 1/4W	1066-6805	Allen-Bradley	CB6805
	TRANSFORMER			
T1	Toroidal Bifilar	1579-0031	Cushman	
	TRANSISTORS			
Q1	Si, NPN, 2N3563	1272-0022	Fairchild	2N3563
Q2	J-FET, N-Channel	1272-0048	Teledyne	2N4416
Q3	Si, PNP, 2N4249	1272-0024	Fairchild	2N4249
Q4	Si, NPN, 2N4275	1272-0016	Fairchild	2N4275
Q5	Si, PNP, 2N3906	1272-0037	Motorola	2N3906
Q6	Si, NPN, 2N3904	1272-0032	Motorola	2N3904
Q7	Si, NPN, 2N3904	1272-0032	Motorola	2N3904
Q8	Si, NPN, 2N5179	1272-0060	Motorola	2N5179
Q9	Si, NPN, 2N5179	1272-0060	Motorola	2N5179
Q10	Si, NPN, 2N5179	1272-0060	Motorola	2N5179
Q11	Si, NPN, 2N5179	1272-0060	Motorola	2N5179

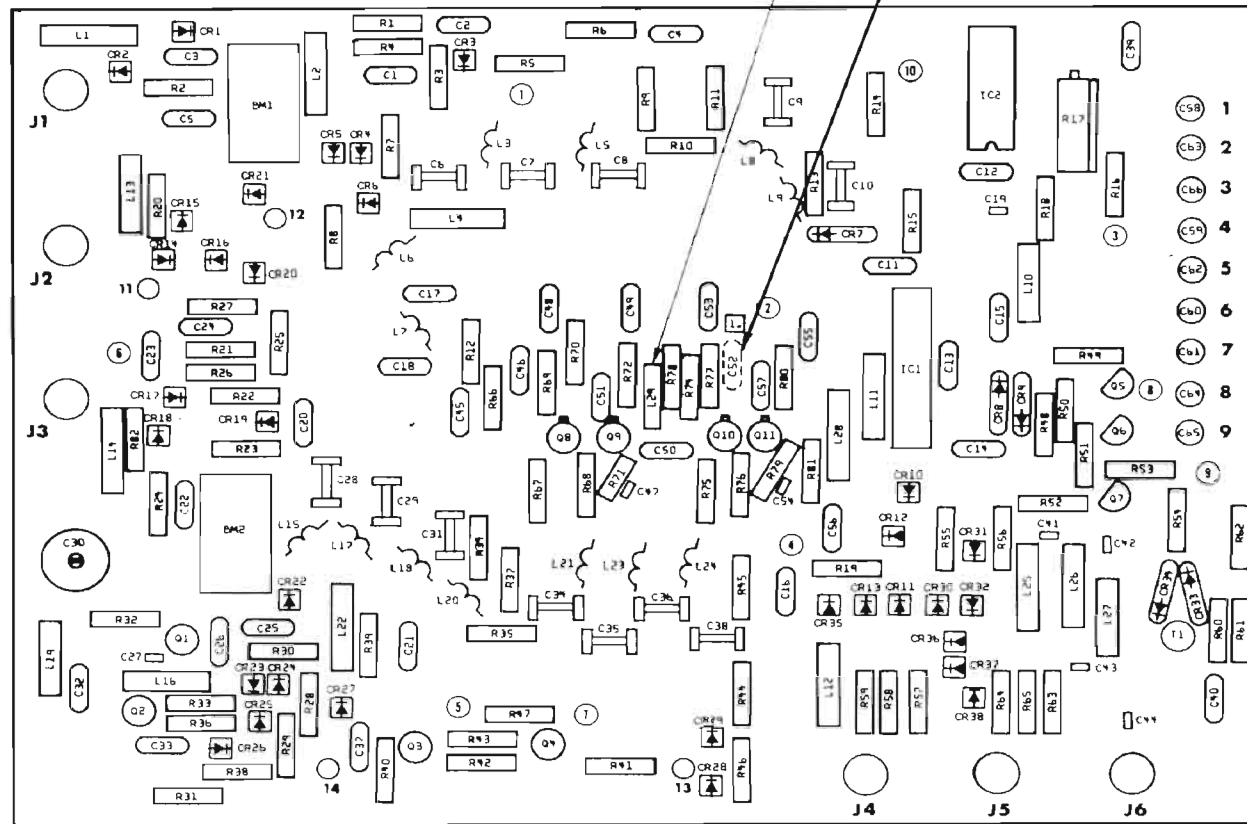

- 1. INSTALLED IN SOME UNITS IN FINAL TEST.
- 2. 180 Ω RESISTOR INSTALLED IN SOME UNITS.

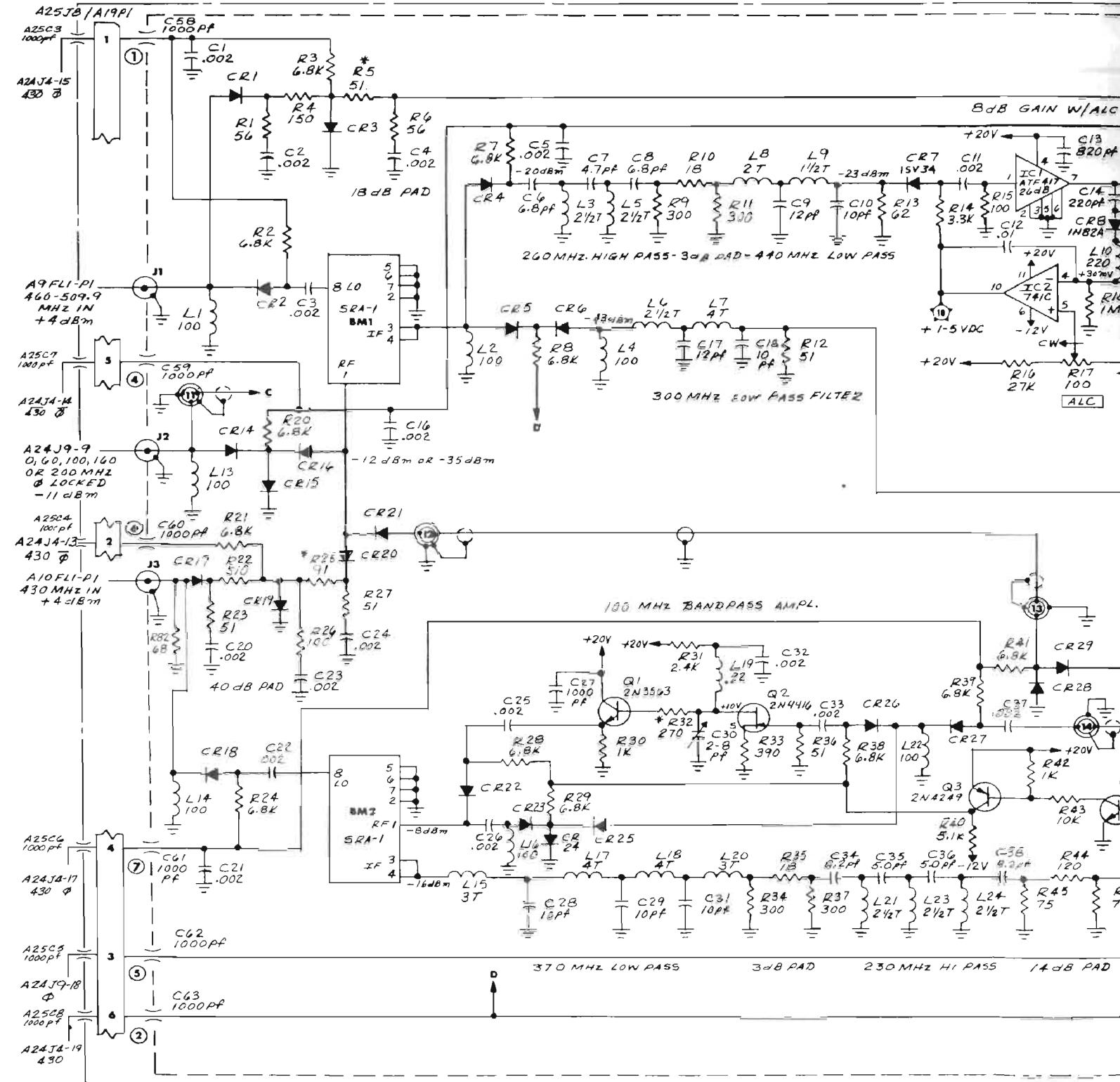

- NOTE:
- 1. RESISTORS - 1/4W, 5% VALUES IN OHMS UNLESS OTHERWISE NOTED.
 - 2. CAPACITORS - VALUES IN μ F UNLESS OTHERWISE NOTED.
 - 3. INDUCTORS - VALUES IN μ H UNLESS OTHERWISE NOTED.
 - 4. *FACTORY SELECT - TYPICAL VALUE SHOWN.
 - 5. ALL VOLTAGES ARE DC UNLESS OTHERWISE NOTED.
 - 6. ALL DIODES ARE MPM-3901 UNLESS OTHERWISE NOTED.
 - 7. INSTALLED IN SOME UNITS IN FINAL TEST.
 - 8. 180 Ω RESISTOR INSTALLED IN SOME UNITS.

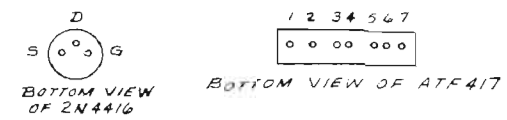

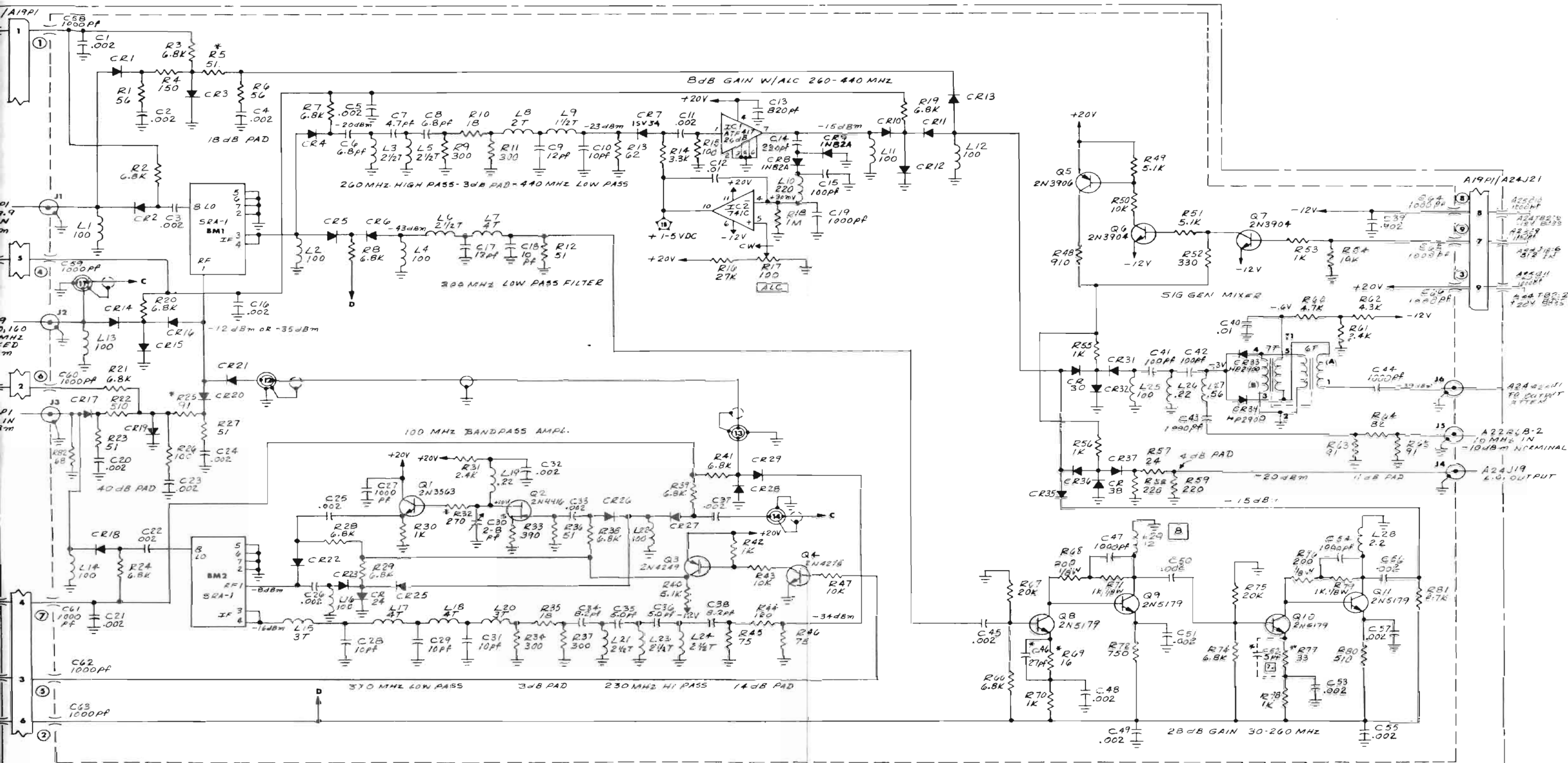

- NOTE:
1. RESISTORS - 1/4W, 5% VALUES, IN OHMS UNLESS OTHERWISE NOTED.
 2. CAPACITORS - VALUES IN μ F UNLESS OTHERWISE NOTED.
 3. INDUCTORS - VALUES IN μ M UNLESS OTHERWISE NOTED.
 4. *FACTORY SELECT. TYPICAL VALUE SHOWN.
 5. ALL VOLTAGES ARE DC UNLESS OTHERWISE NOTED.
 6. ALL DIODES ARE MPN-3REL UNLESS OTHERWISE NOTED.
 7. INSTALLED IN SOME UNITS IN FINAL TEST.
 8. 180 Ω RESISTOR INSTALLED IN SOME UNITS.

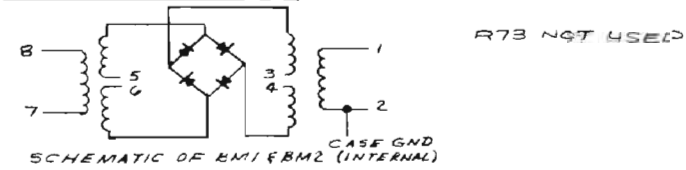
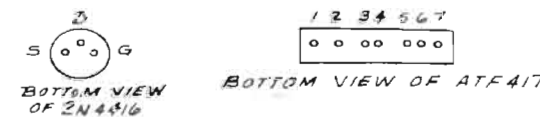

Figure 6-18. RF Mixers and IF Amplifier. A19
6-91/6-92

FRONT PANEL ASSEMBLY, A22

CKT. REF.	DESCRIPTION	CE STOCK NO.	MFR.	MFR. NO.
A22	Front Panel Assy	7003-0063	Cushman	
	CAPACITORS			
C1	Mica, 150pF, $\pm 5\%$, 500V	1002-0021	Elmenco	DM15-F-151J
C2	Poly, .68 μ F, $\pm 10\%$, 100V	1008-0039	Electrocube	625B1C394K2
C3	Cer, .05 μ F, +80-20%, 25V	1005-0014	Erie	5855-505-Y5U0-503Z
	COILS			
L1	RF Choke, 10 μ H, $\pm 10\%$	1585-0016	Delevan	1537-36
	CONNECTORS			
J1	BNC Type Bulkhead	2536-0010	Kings	KC79-35
J2	BNC Type Bulkhead	2536-0010	Kings	KC79-35
J3	BNC Type Bulkhead	2536-0010	Kings	KC79-35
J4	BNC Type Bulkhead	2536-0010	Kings	KC79-35
J5	Bulkhead Feed Thru	2536-0038	Kings	KC99-54
	LAMPS			
XDS1	Connector	2900-0004	Dialco	515-0050
DS1	Indicator, Red	2870-0010	Dialco	507-3910-1431-600
DS2	Neon Lamp, NE-2 or Equivalent	2871-0001	Chi. Miniature	Ne-2
DS3	Lamp, W/1.5" Leads	2870-0011	Chi. Miniature	7-7382
DS4	Lamp, W/1.5" Leads	2870-0011	Chi. Miniature	7-7382
DS5	Lamp, W/1.5" Leads	2870-0011	Chi. Miniature	7-7382
DS6	Lamp, W/1.5" Leads	2870-0011	Chi. Miniature	7-7382
DS7	Lamp, W/1.5" Leads	2870-0011	Chi. Miniature	7-7382
DS8	Lamp, W/1.5" Leads	2870-0011	Chi. Miniature	7-7382
DS9	Lamp, W/1.5" Leads	2870-0011	Chi. Miniature	7-7382
DS10	Lamp, W/1.5" Leads	2870-0011	Chi. Miniature	7-7382
DS11	Lamp, W/1.5" Leads	2870-0011	Chi. Miniature	7-7382
	METER			
M1	Meter Frequency, w/Bezel	C1402-0018	Cushman	
	RESISTORS			
R1	Comp, 68k Ω , $\pm 5\%$, 1/4W	1066-6835	Allen-Bradley	CB6835
R2	Pot, 250 Ω , $\pm 10\%$, 2W	1203-0019	Allen-Bradley	JA4N048P251UA
R3/S10	Pot, Var, 10k Ω , w/switch	1203-0018	Allen-Bradley	JS4N048P103UA
R4	Comp, 470k Ω , $\pm 5\%$, 1/4W	1066-4745	Allen-Bradley	CB4745
R5	Pot, Var, 1k/500k, Dual	1204-0003	Allen-Bradley	JJC91400C
R6/S14	Pot, 2.5k, $\pm 20\%$, 1/2W	1203-0053	CTS	GC321-X4P1385
R7	Not used			
R8	Not Used			
R9	Not Used			
R10	Not Used			
R11	Not Used			
R12	P/O S8			
	SWITCHES			
S1	Rotary 4 pole, 7 position	1851-0039	Cushman	
S2	Rotary 3 pole, 10 position	1851-0058	Cushman	
S3	Rotary 4 pole, 10 position	1851-0027	Cushman	
S4	Rotary 4 pole, 10 position	1851-0027	Cushman	
S5	Rotary 4 pole, 10 position	1851-0027	Cushman	

FRONT PANEL ASSEMBLY (cont). A22

CKT. REF.	DESCRIPTION	CE STOCK NO.	MFR.	MFR. NO.
S6	Rotary 4 pole, 10 position	1851-0027	Cushman	
S7	Lever, w/knob	1851-0016	Cushman	
S8/R12	Switch, Function, w/pot	1851-0025	Cushman	
S9	4 pole, 2 position, Shorting	1851-0022	Centralab	PA-1010
S10	P/O R3			
S11	Toggle, SPDT, w/mtg hdw	1850-0008	C&K Comp.	7101
S12	Rotary 2 pole, 3 position	1851-0079	Cushman	
S13	Relay, Turn Indicator, .6A, 12V	1313-0006	Signal Stat	175Y1
S14	P/O R6			
	TERMINAL BOARD			
TB1	Tiepoint, Miniature, 5 Pin	1760-0012	Smith	1157
TB2	Terminal Board	1760-0014	Cushman	
TB3	Terminal Board	1760-0014	Cushman	
TB4	Terminal Board	1760-0014	Cushman	
TB5	Terminal Board	1760-0014	Cushman	
TB6	Terminal Board	1760-0014	Cushman	

→ MHZ

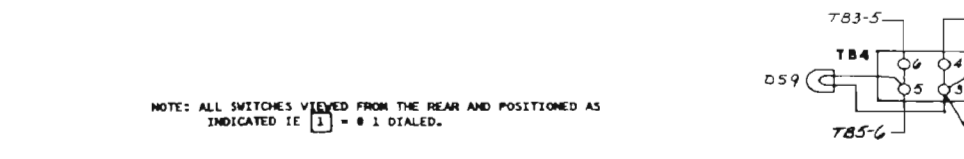
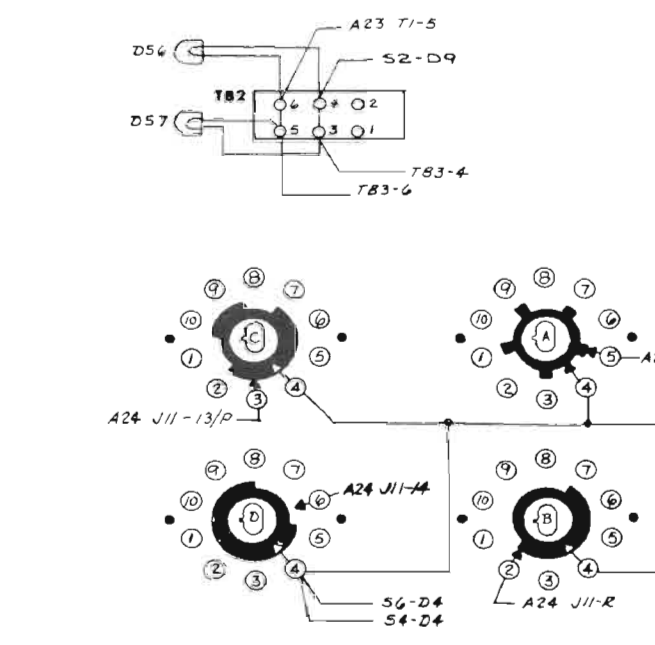
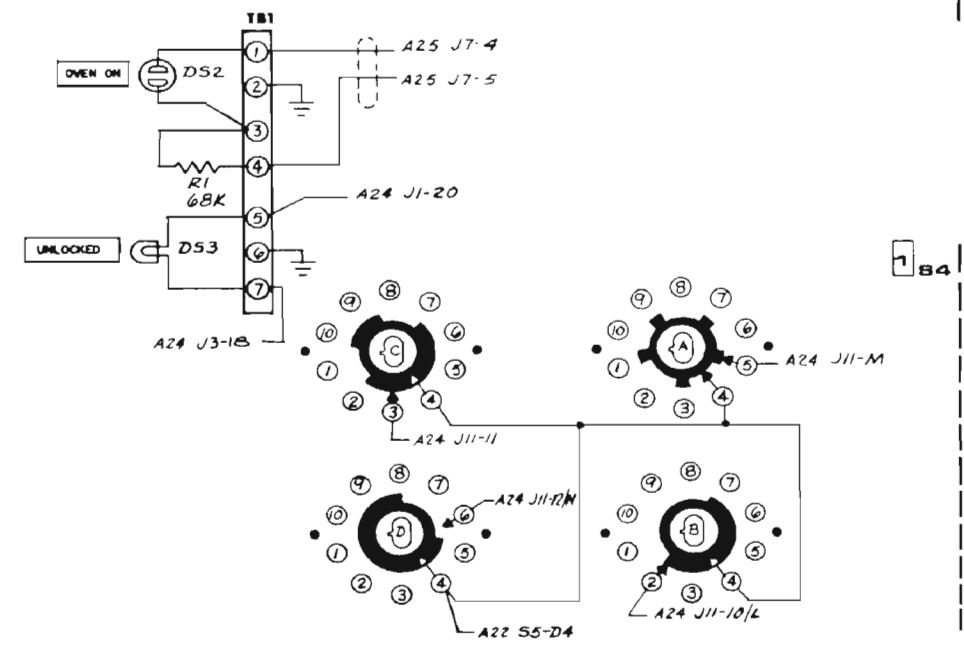
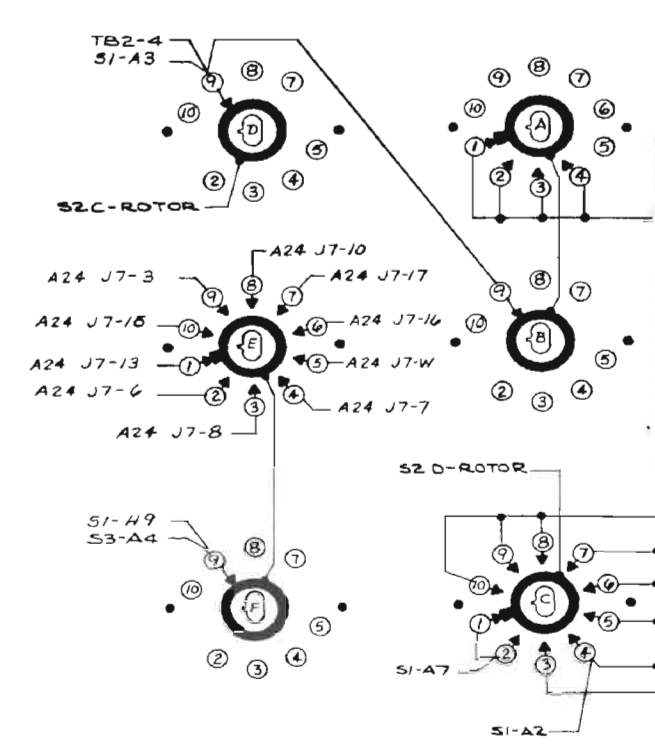
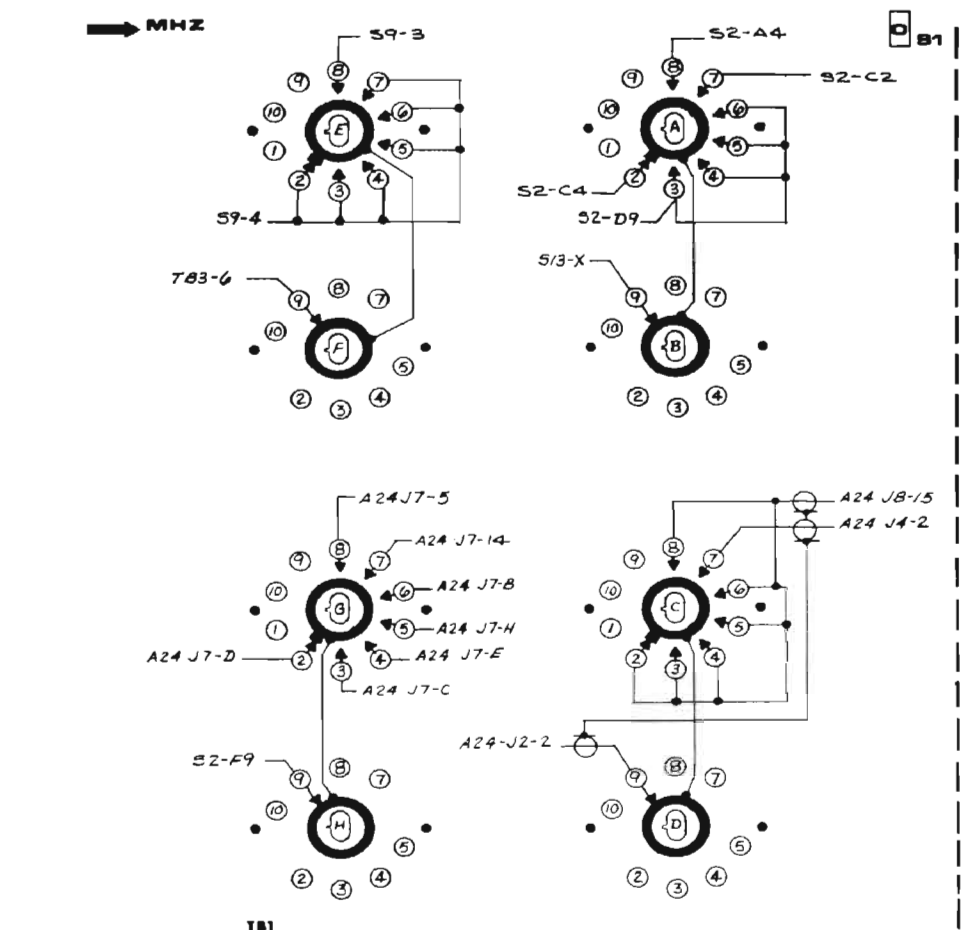

NOTE: ALL SWITCHES VIEWED FROM THE REAR AND POSITIONED AS INDICATED IE 1 = 0 1 DIALED.

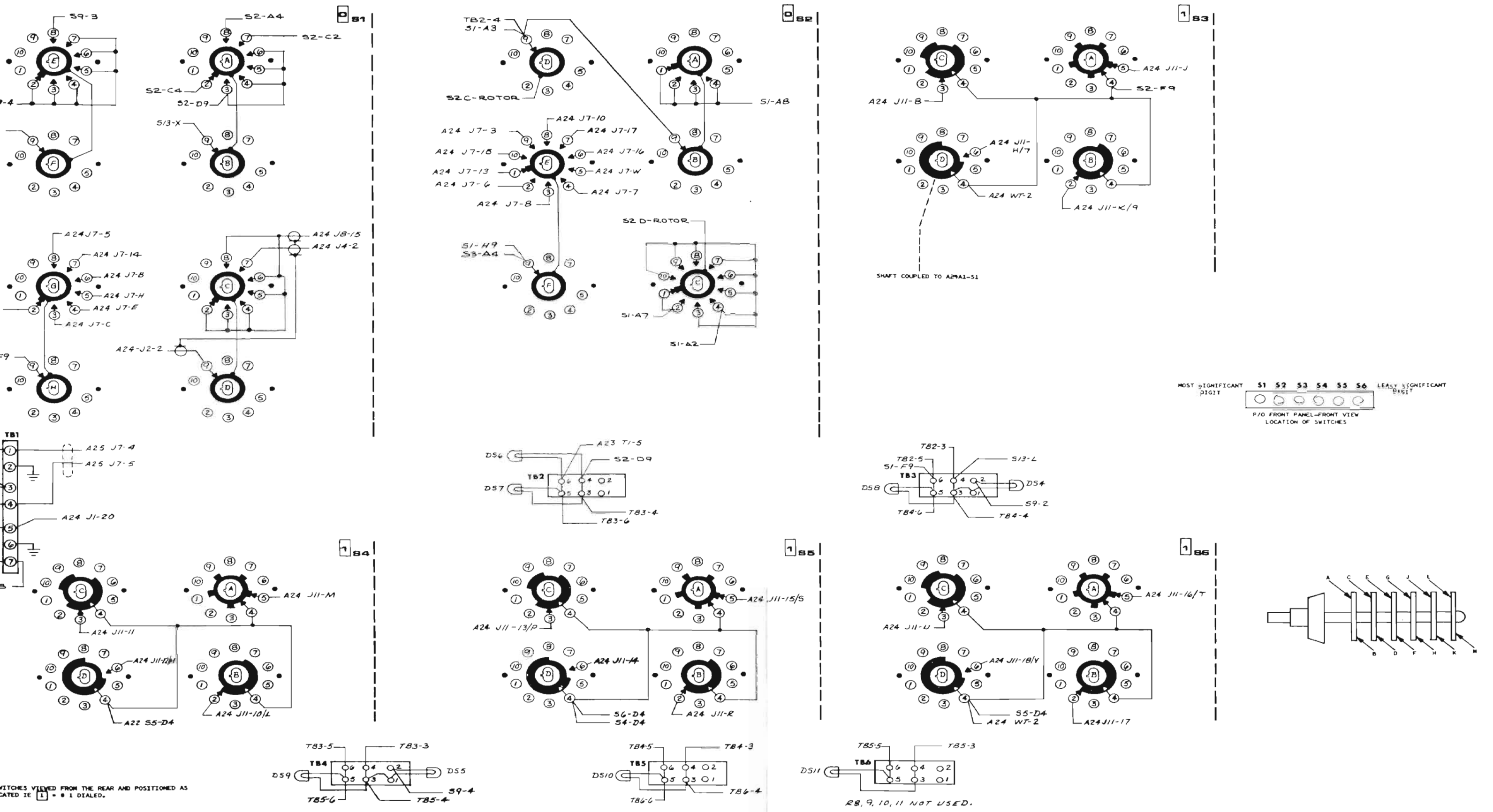
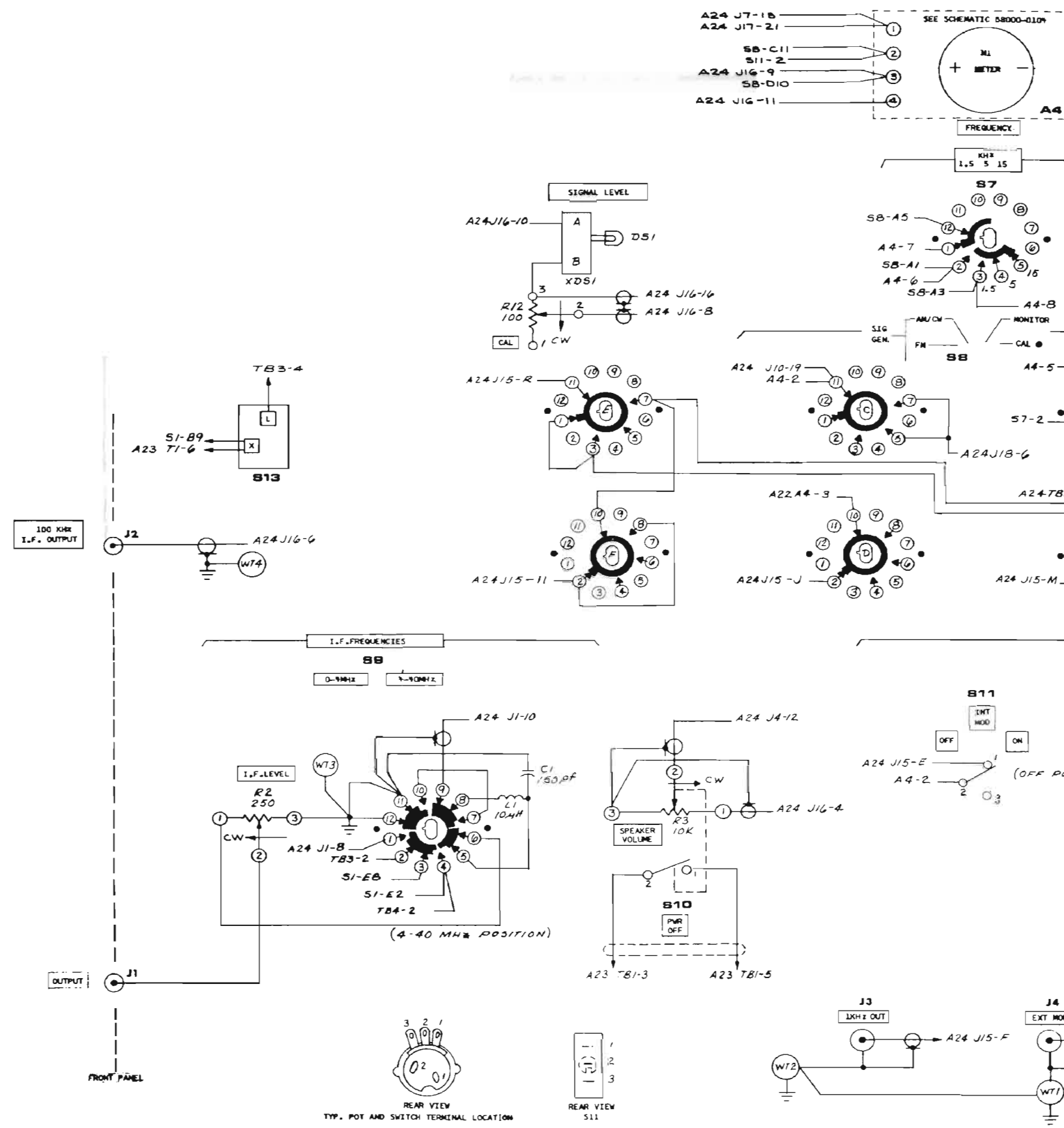
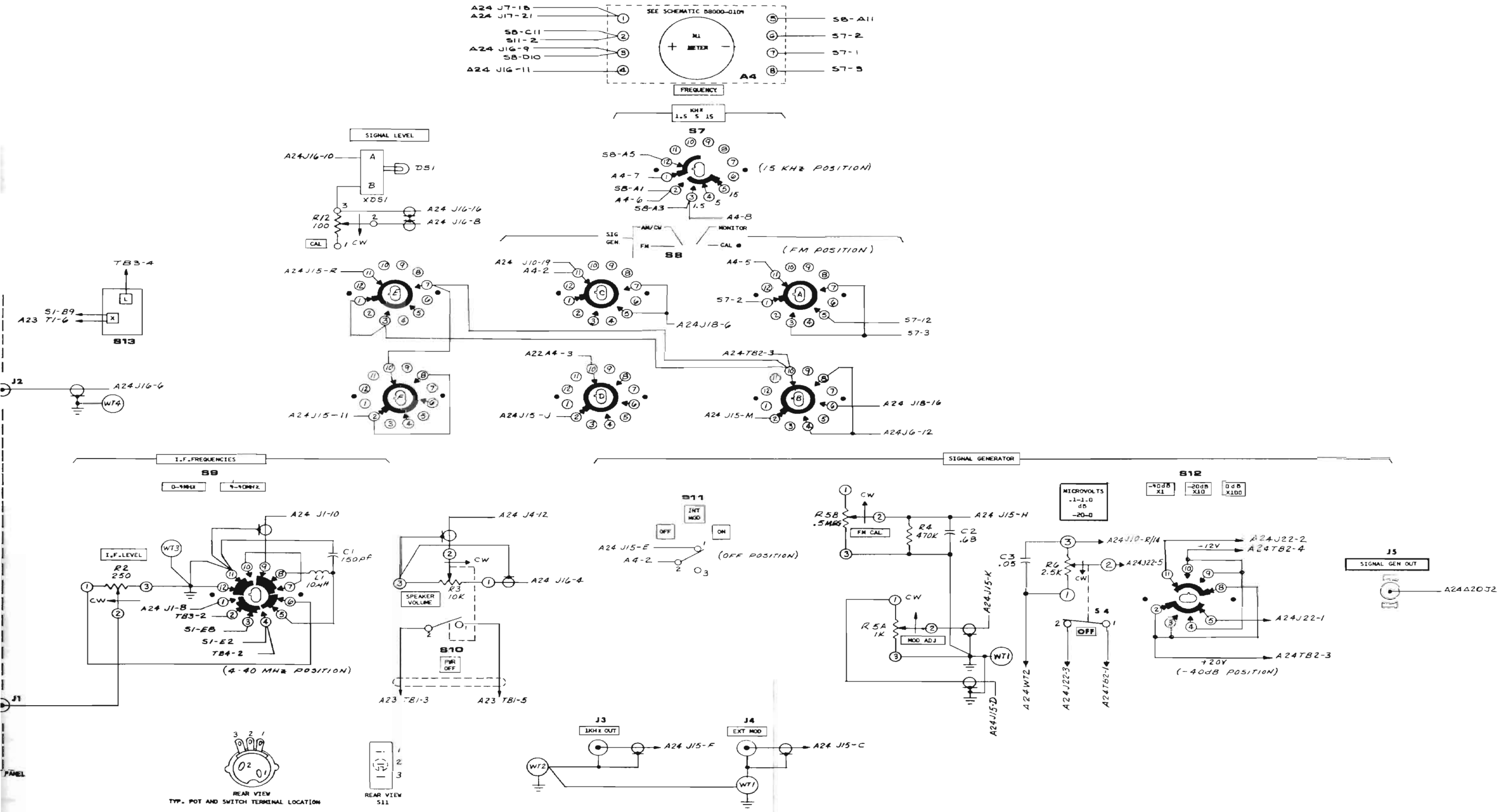

Figure 6-19. Interconnection Diagram, Front Panel, Sheet 1. A22 6-95/6-96



NOTE: ALL SWITCHES VIEWED FROM THE REAR.



NOTE: ALL SWITCHES VIEWED FROM THE REAR.

Figure 6-20. Interconnection Diagram, Front Panel, Sheet 2. A22

REAR PANEL ASSEMBLY. A23

CKT. REF.	DESCRIPTION	CE STOCK NO.	MFR.	MFR. NO.
A23	Panel Assy, Rear	7003-0064	Cushman	
	CAPACITORS			
C1	Not Used			
C2	Cer, 2200pF, $\pm 20\%$, 3kV	1005-0098	Sprague	30GA-D22
C3	Cer, 2200pF, $\pm 20\%$, 3kV	1005-0098	Sprague	30GA-D22
	Coils			
L1	Choke, 100 μ H, $\pm 20\%$, 2 amp	1585-0040	Miller	B-6021
L2	Choke, 100 μ H, $\pm 20\%$, 2 amp	1585-0040	Miller	B-6021
	FUSES			
F1	1 amp, Slo Blo, 3AG	1955-0006	Littlefuse	3AG-313001
F2	.2 amp, Slo Blo, 3AG	1955-0009	Bussman	MDL 2/10
XF1	Holder, Fuse	1965-0015	Littlefuse	342-001-AL
XF2	Holder, Fuse	1965-0015	Littlefuse	342-001-AL
	TERMINAL BOARD			
TB1	Tiepoint, 7 pin, #55C	1760-0013	Cinch Jones	#55C
	TRANSFORMER			
T1	Transformer, Power	1575-0006	Cushman	
T2	Transformer, Isolation	1575-0023	Cushman	

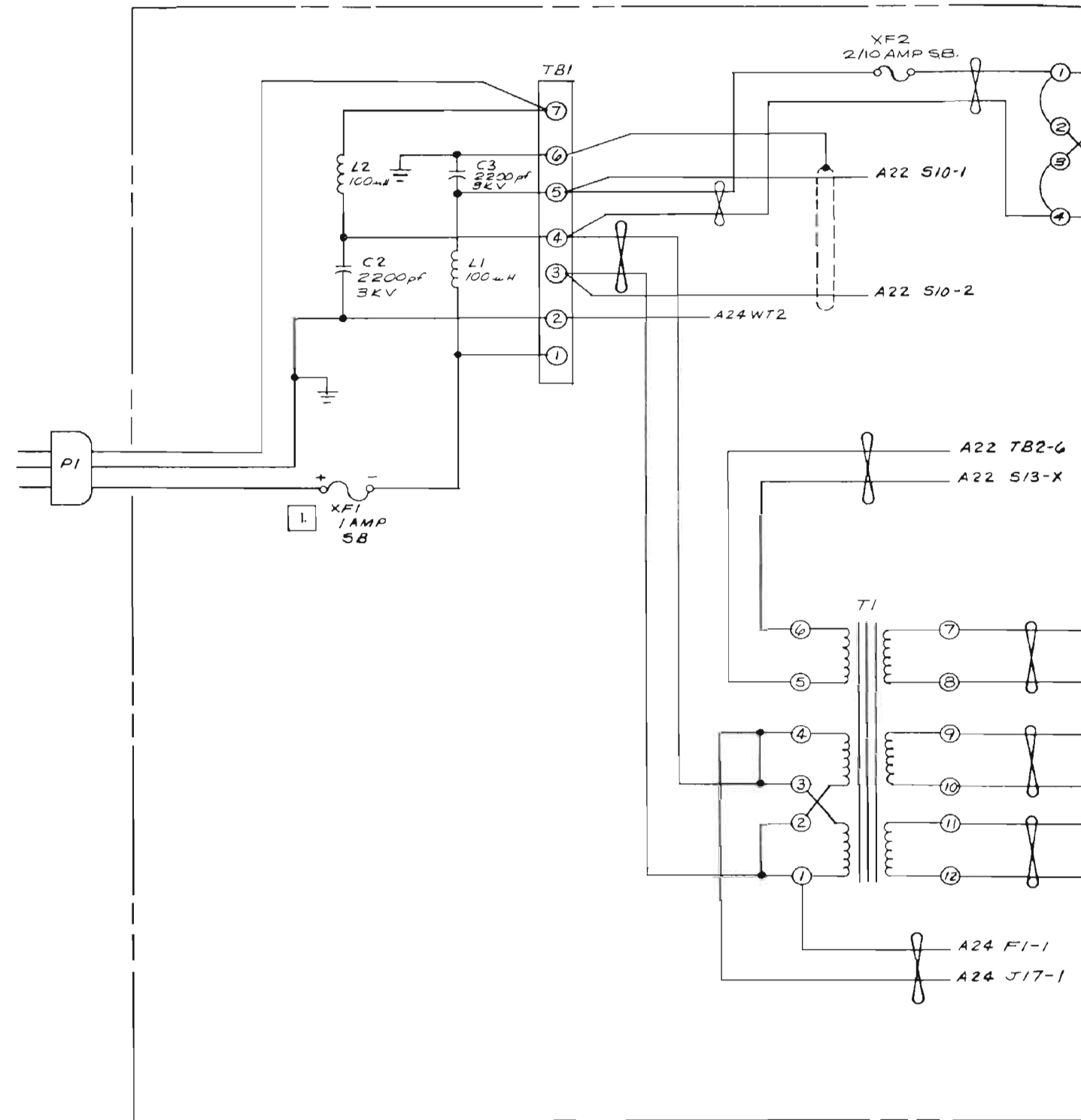

NOTES: 1. POSITIVE AND NEGATIVE SYMBOLS ARE MARKED ON FUSE HOLDER TERMINALS.

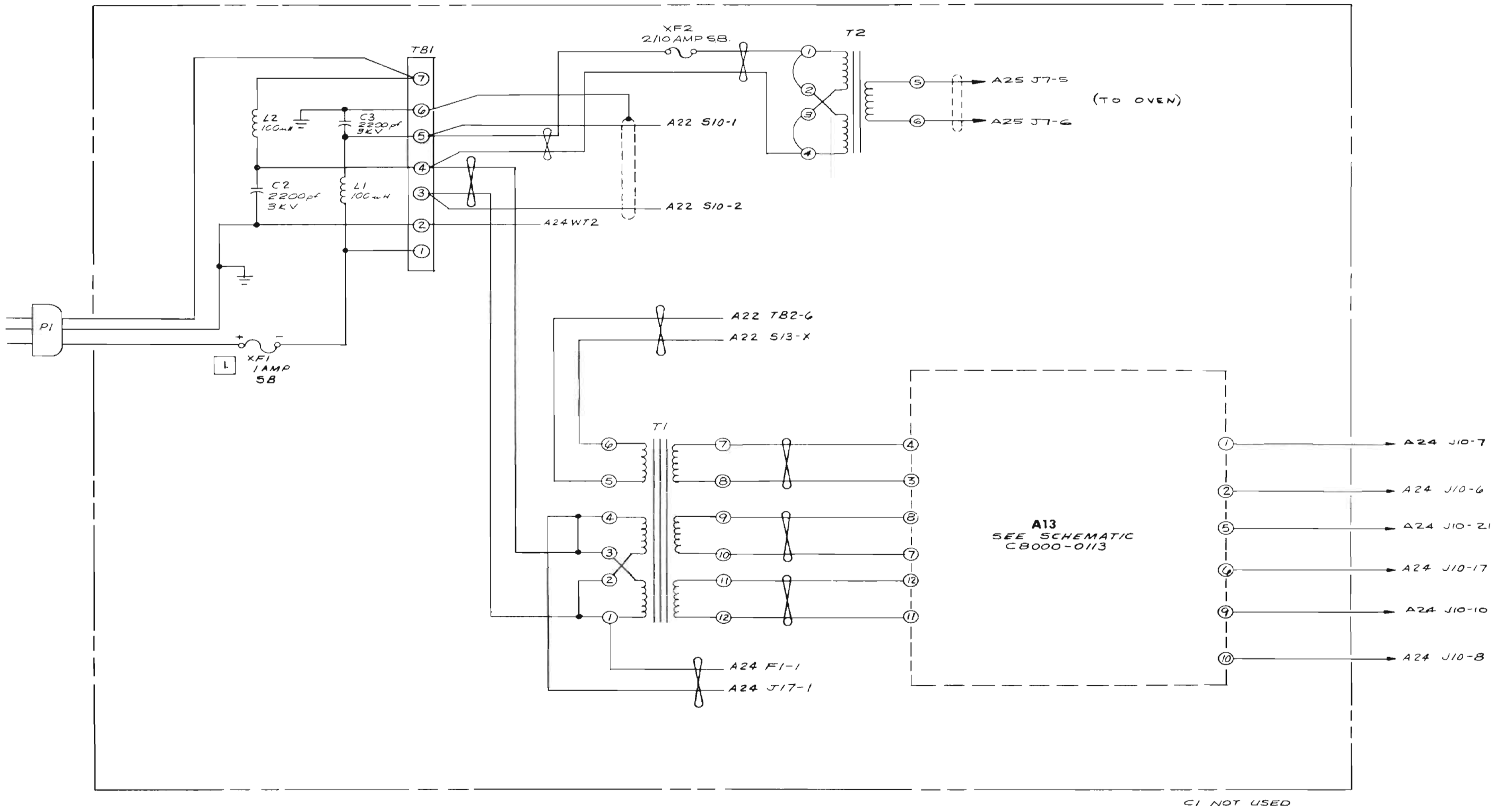

1. POSITIVE AND NEGATIVE SYMBOLS ARE MARKED ON FUSE HOLDER TERMINALS.

Figure 6-21. Wiring Diagram, Rear Panel. A23
6-101/6-102

MAIN CHASSIS ASSEMBLY. A24

CKT. REF.	DESCRIPTION	CE STOCK NO.	MFR.	MFR. NO.
A24	Main Assembly		Cushman	
	Main Chassis Assembly	7007-0017	Cushman	
	CAPACITOR			
C1	Cer, .05 μ F, +80 -20%, 25V	1005-0014	Erie	5855-505-Y5U0-503Z
C2	Cer, .05 μ F, +80 -20%, 25V	1005-0014	Erie	5855-505-Y5U0-503Z
	CONNECTORS			
J1	Connector, 22 pin	2535-0018	Viking	2VK22S11-1
J2	Connector, 22 pin	2535-0018	Viking	2VK22S11-1
J3	Connector, 22 pin	2535-0018	Viking	2VK22S11-1
J4	Connector, 22 pin	2535-0018	Viking	2VK22S11-1
J5	Connector, 22 pin	2535-0018	Viking	2VK22S11-1
J6	Connector, 22 pin	2535-0018	Viking	2VK22S11-1
J7	Connector, 22 Contact, 44 pin	2535-0023	Viking	2VK22D/1-1
J8	Connector, 22 pin	2535-0018	Viking	2VK22S11-1
J9	Connector, 22 pin	2535-0018	Viking	2VK22S11-1
J10	Connector, 22 pin	2535-0018	Viking	2VK22S11-1
J11	Connector, 22 Contact, 44 pin	2535-0023	Viking	2VK22D/1-1
J12	Not Used			
J13	Not Used			
J14	Not Used			
J15	Connector, 22 Contact, 44 pin	2535-0023	Viking	2VK22D/1-1
J16	Connector, 22 pin	2535-0018	Viking	2VK22S11-1
J17	Connector, 24 pin female	2535-0020	Amphenol	25-190-24
J18	Connector, 24 pin female	2535-0020	Amphenol	25-190-24
J19	BNC Connector	2536-0039	Specialty Co	28JS140-3
J20	Not used			
J21	Not used			
J22	Connector 6 pin mini plug housing	2535-0049	Molex	R03-06-1061
	Pin, Female, contact crimp (6)	4153-0006	Molex	1561TL
	Extender, P. C. Board Assy	1780-0085	Cushman	
	CONNECTORS			
	22 Contact, 44 terminal, Double row	2535-0023	Viking	2VK22D/1-1
LS1	Speaker, 3" x 5", 22 ohm	1715-0003	Quam	74-6248

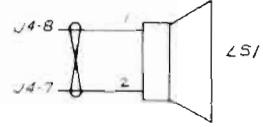
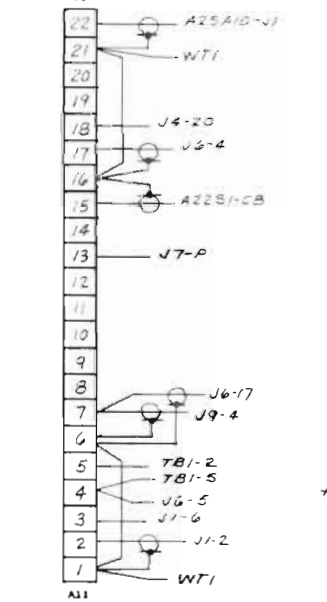
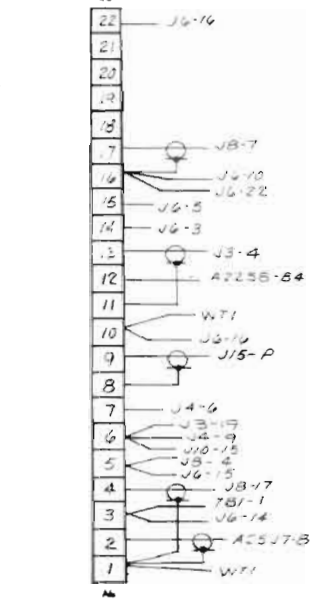
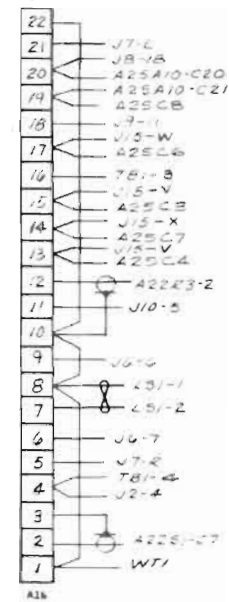
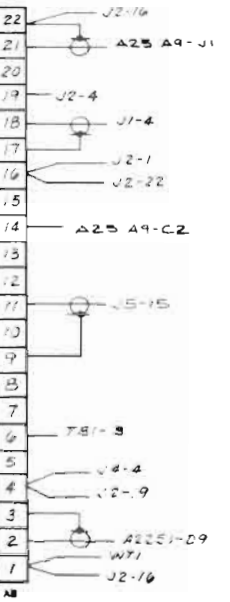
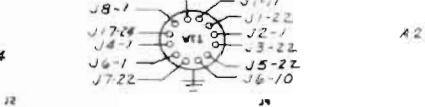
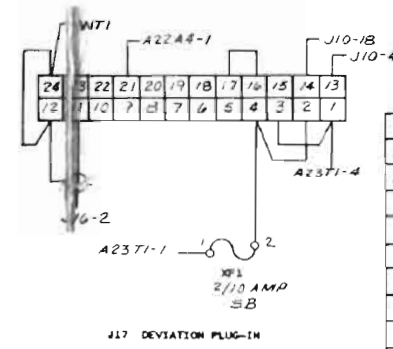
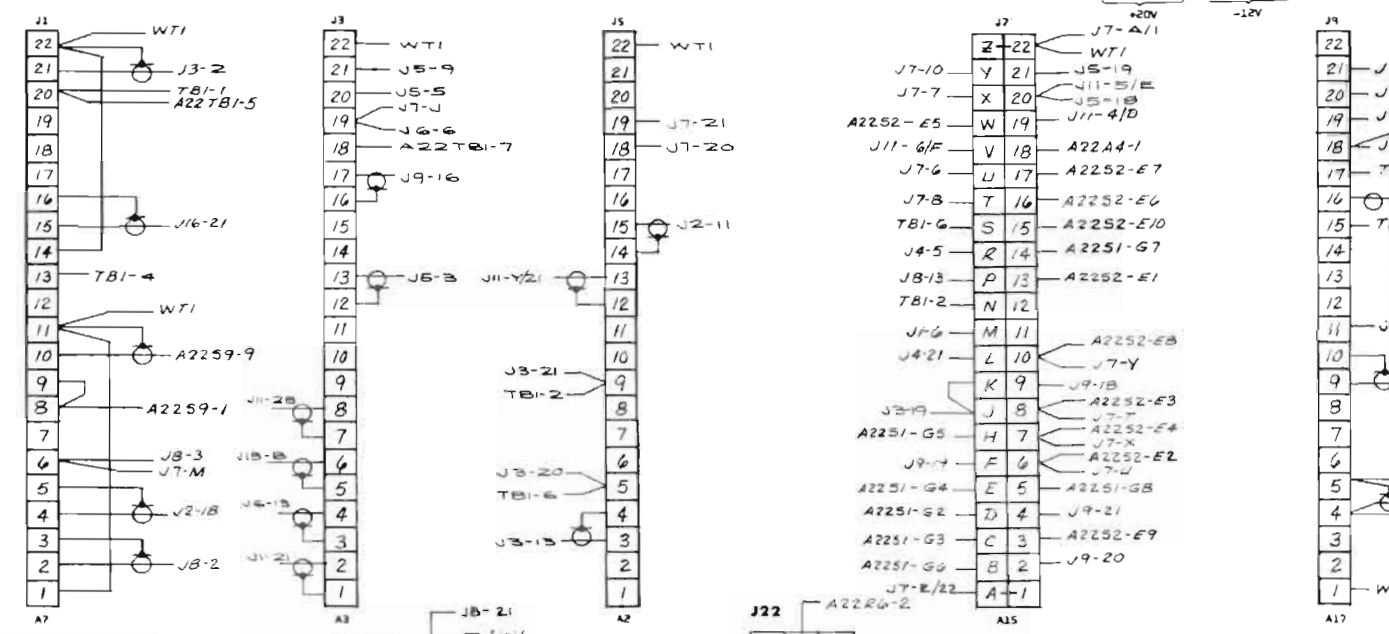

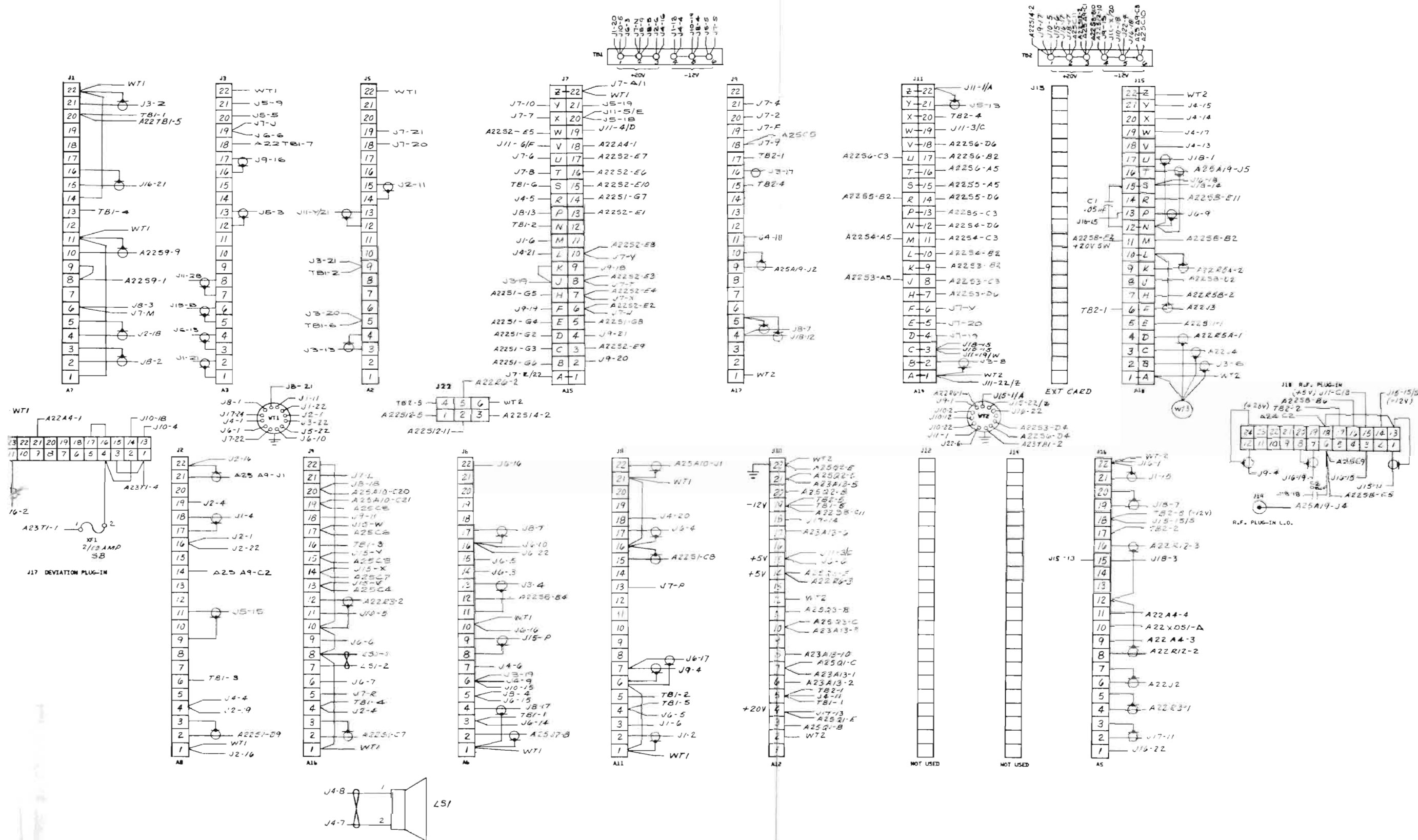
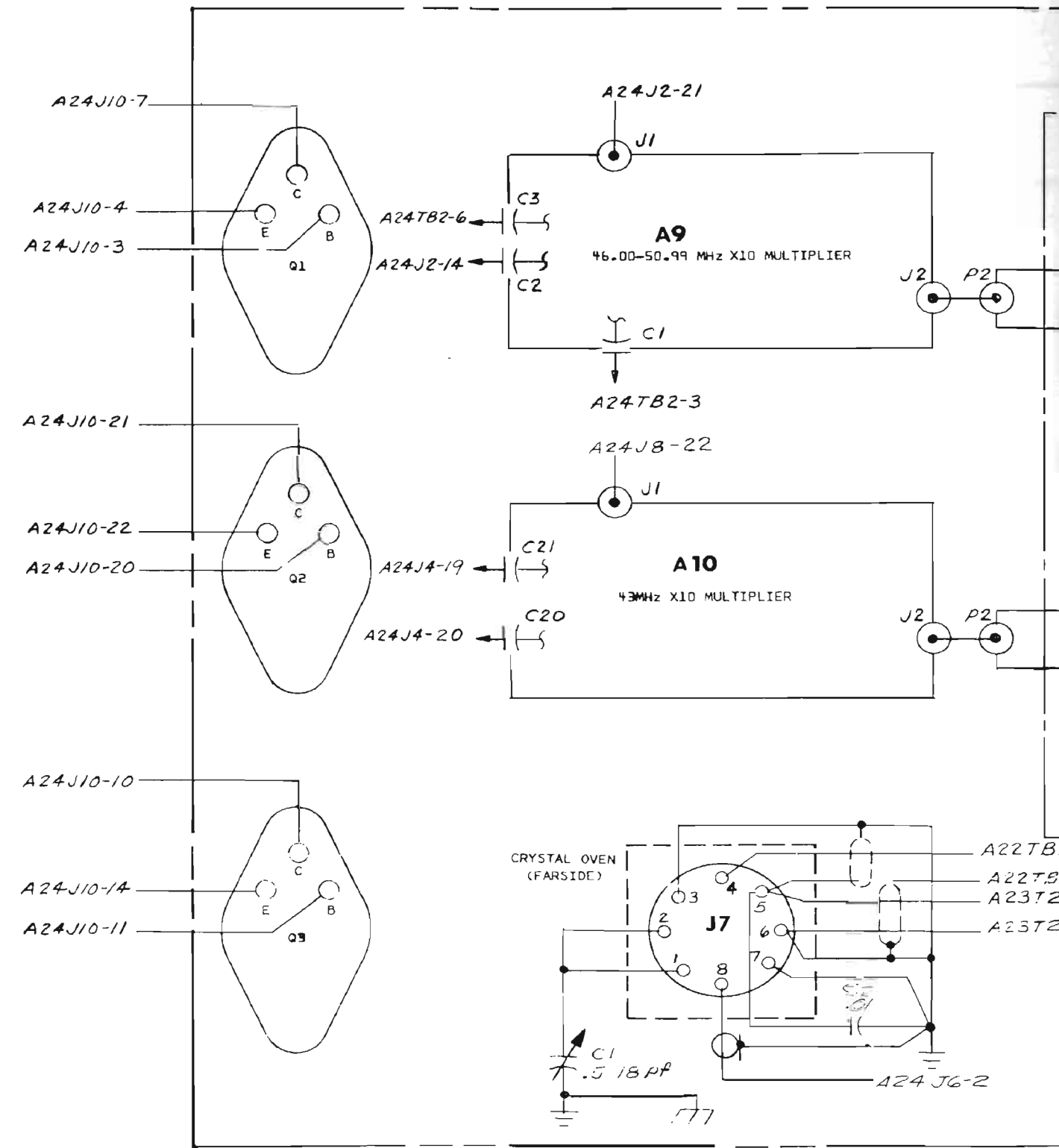

Figure 6-22. Interconnection Diagram, Main Chassis. A24
6-105/6-106

CENTER PLATE ASSEMBLY. A25

CKT. REF.	DESCRIPTION	CE STOCK NO.	MFR.	MFR. NO.
A25	Plate Assy, Center	7013-1003	Cushman	
	CAPACITOR			
C1	Var, .5-18pF, 750V	1001-0001	JFD Elec.	VCJ2611
C2	Cer, .01 μ F, 1.4 kV	1005-0051	Sprague	125L-S10
	CONNECTOR			
J7	Socket, Octal	2605-0001	Cench-Jones	8 EM
	TRANSISTORS			
Q1	Si, NPN, 2N3054	1271-0001	RCA	2N3054
Q2	Si, NPN, 2N3054	1271-0001	RCA	2N3054
Q3	Si, NPN, 2N3054	1271-0001	RCA	2N3054



NOTE:

1. RESISTORS - 1/4W, 5% VALUES IN OHMS UNLESS OTHERWISE NOTED.
2. CAPACITORS - VALUES IN μ F UNLESS OTHERWISE NOTED.
3. INDUCTORS - VALUES IN μ H UNLESS OTHERWISE NOTED.
4. *FACTORY SELECT. TYPICAL VALUE SHOWN.
5. ALL VOLTAGES ARE DC UNLESS OTHERWISE NOTED.

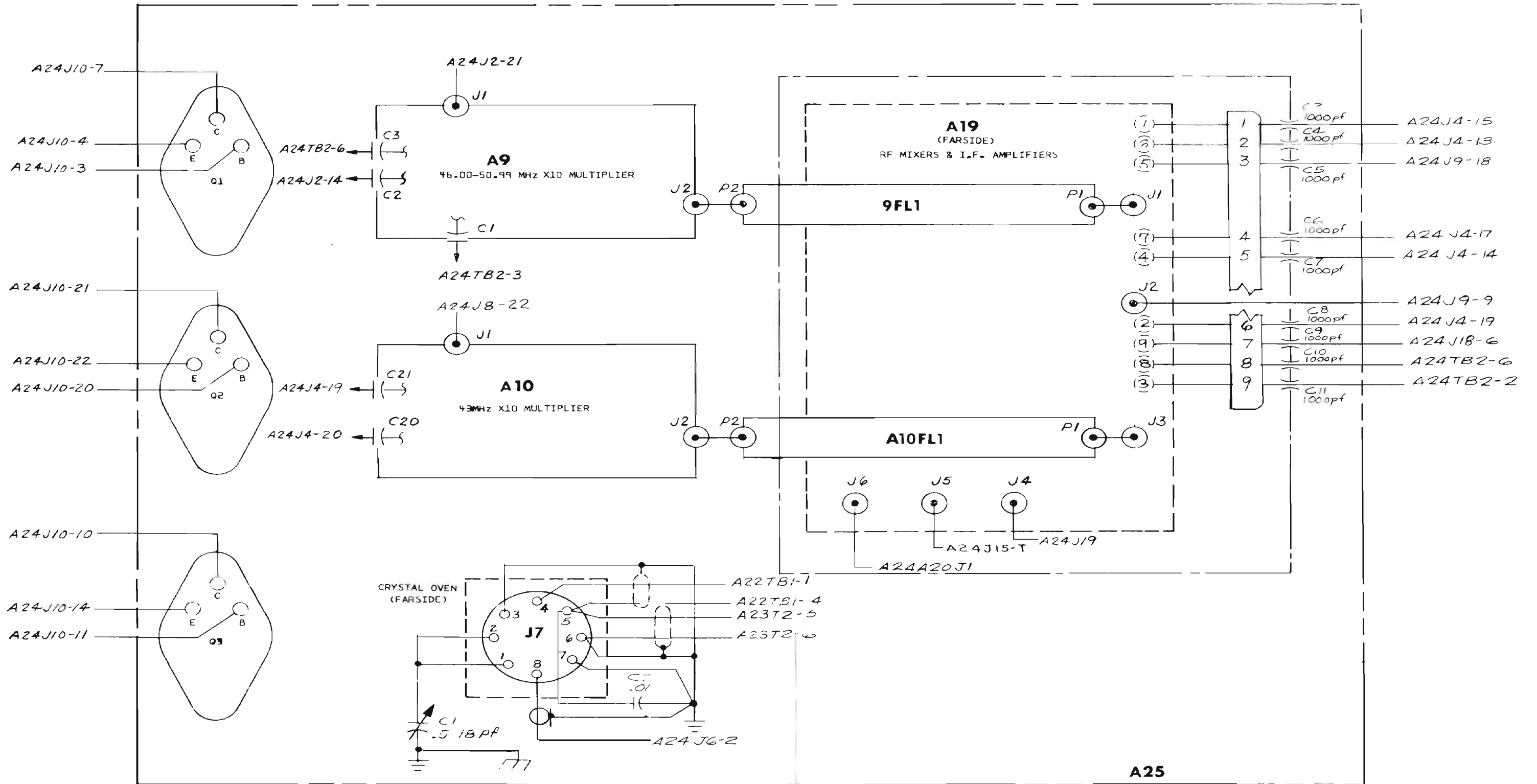

NOTE:

1. RESISTORS - 1/4W, 5% VALUES IN OHMS UNLESS OTHERWISE NOTED.
2. CAPACITORS - VALUES IN μ F UNLESS OTHERWISE NOTED.
3. INDUCTORS - VALUES IN μ H UNLESS OTHERWISE NOTED.
4. *FACTORY SELECT. TYPICAL VALUE SHOWN.
5. ALL VOLTAGES ARE DC UNLESS OTHERWISE NOTED.

Figure 6-23. Interconnection Diagram,
Center Plate. A25

20 dB PAD ASSEMBLY

CKT. REF.	DESCRIPTION	CE STOCK NO.	MFR.	MFR. NO.
	Pad Assembly - 20dB	7040-0016	Cushman	
	CONNECTORS			
P1	BNC Recp. w/mtg hdw	2536-0010	Kings	KC79-35
	FUSE			
F1	Fuse, 1/32 amp	1955-0005	Buss	GFA 1/32
	RESISTORS			
R1	Comp, 62 Ω , $\pm 5\%$, 1/4W	1066-6205	Allen-Bradley	CB6205
R2	Comp, 220 Ω , $\pm 5\%$, 1/4W	1066-2215	Allen-Bradley	CB2215
R3	Comp, 62 Ω , $\pm 5\%$, 1/4W	1066-6205	Allen-Bradley	CB6205

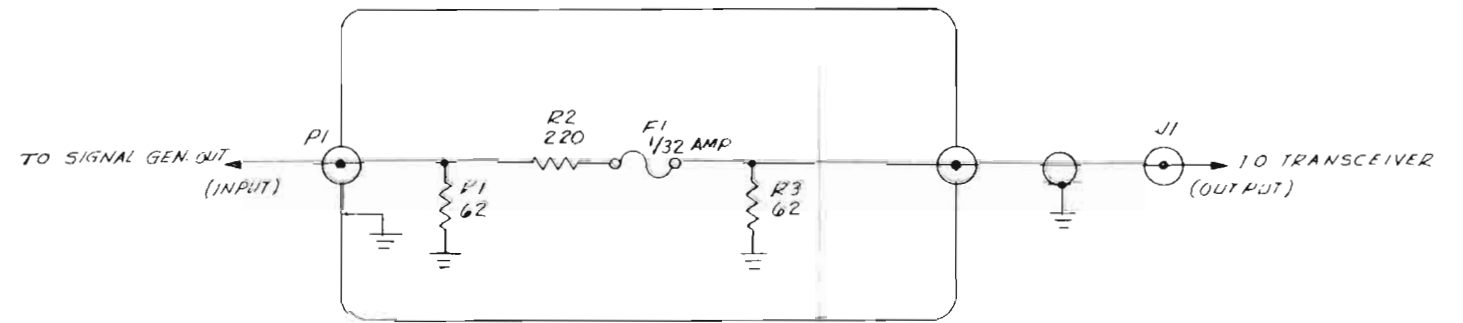

- NOTE:
1. RESISTORS - 1/4W, 5% VALUES IN OHMS UNLESS OTHERWISE NOTED.
 2. CAPACITORS - VALUES IN μ P UNLESS OTHERWISE NOTED.
 3. INDUCTORS - VALUES IN μ H UNLESS OTHERWISE NOTED.
 4. *FACTORY SELECT, TYPICAL VALUE SHOWN.
 5. ALL VOLTAGES ARE DC UNLESS OTHERWISE NOTED.

Figure 6-24. 20 dB Pad Assembly
6-113/6-114

CKT. REF.	DESCRIPTION	CE STOCK NO.	MFR.	MFR. NO.
A20	PC Bd Assy, Output Attenuator CE5 PC Board	7001-0272 1780-0461	Cushman Cushman	
	CAPACITORS			
C1	Cap, 1000PF, 10%, 100V Min Cer	1005-0081	Erie	8121-100-W5R-102K
C2	Cap, 1000PF, 10%, 100V Min Cer	1005-0081	Erie	8121-100-W5R-102K
C3	Cap, 1000PF, 10%, 100V Min Cer	1005-0081	Erie	8121-100-W5R-102K
C4	Cap, 1000PF, 10%, 100V Min Cer	1005-0081	Erie	8121-100-W5R-102K
C5	Cap, 1000PF, 10%, 100V Min Cer	1005-0081	Erie	8121-100-W5R-102K
C6	Cap, 1000PF, 10%, 100V Min Cer	1005-0081	Erie	8121-100-W5R-102K
C7	Cap, 1000PF, 10%, 100V Min Cer	1005-0081	Erie	8121-100-W5R-102K
C8	Cap, 1000PF, 10%, 100V Min Cer	1005-0081	Erie	8121-100-W5R-102K
C9	Cap, 1000PF, 10%, 100V Min Cer	1005-0081	Erie	8121-100-W5R-102K
C10	Cap, 12PF, 5%, 500V Mica	1002-0017	Elmenco	DM15-C-120J
C11	Cap, 15 μ F, 10%, 25V	1013-0005	Sprague	30D156G025BB5
C12	Cap, .01 μ F, +80-20%, 25V Disc	1005-0013	Erie	5835-512-Y5U-103Z
C13	Cap, 10PF, 5%, 500V Mica	1002-0016	Elmenco	DM15-C-100J
C14	Cap, 39PF, 5%, 500V Mica	1002-0018	Elmenco	DM15-E-390J
C15	Cap, .01 μ F, 20%, 100V Mini	1005-0100	Erie	8121-100-651-103M
C16	Cap, .01 μ F, 20%, 100V Mini	1005-0100	Erie	8121-100-651-103M
C17	Cap, .01 μ F, 20%, 100V Mini	1005-0100	Erie	8121-100-651-103M
C18	Cap, .01 μ F, 20%, 100V Mini	1005-0100	Erie	8121-100-651-103M
C19	Cap, 10 μ F, 10%, 20V	1011-0007	Kemet	K10C20K
C20	Cap, .05 μ F, +80-20%, 25V Disc	1005-0014	Erie	5855-505-Y5U0-503Z
C21	Not Used			
C22	Not Used			
C23	Not Used			
C24	Not Used			
C25	Not Used			
C26	Not Used			
C27	Cap, 220PF, 10%, 100V Mini	1005-0075	Erie	8101-A100-W5R0-221K
	DIODES			
CR1	Diode, MPN3401	1281-0050	Motorola	MPN3401
CR2	Diode, MPN3401	1281-0050	Motorola	MPN3401
CR3	Diode, MPN3401	1281-0050	Motorola	MPN3401
CR4	Diode, MPN3401	1281-0050	Motorola	MPN3401
CR5	Diode, MPN3401	1281-0050	Motorola	MPN3401
CR6	Diode, MPN3401	1281-0050	Motorola	MPN3401
CR7	Diode, MPN3401	1281-0050	Motorola	MPN3401
CR8	Diode, MPN3401	1281-0050	Motorola	MPN3401
CR9	Diode, Microwave Pin 1SV34	1281-0075	Nippon Elec	1SV34
CR10	Diode, Microwave Pin 1SV34	1281-0075	Nippon Elec	1SV34
CR11	Diode, Microwave Pin 1SV34	1281-0075	Nippon Elec	1SV34
CR12	Diode, Microwave Pin 1SV34	1281-0075	Nippon Elec	1SV34
CR13	Not Used			
CR14	Diode, 1N3064	1281-0013	Teledyne	1N3064
CR15	Diode, 1N3064	1281-0013	Teledyne	1N3064

OUTPUT ATTENUATOR. A20 (cont)

CKT. REF.	DESCRIPTION	CE STOCK NO.	MFR.	MFR. NO.
CR16	Diode, HPA2800	1283-0001	HPA	5082-2800
	FUSE			
F1	Fuse, 1/32 Amp/125 V Plug-in	1955-0022	Littelfuse	273.031
	INDUCTORS			
L1	Assy, Coil Air Core	1596-0076	Cushman	
L2	Assy, Coil Air Core	1596-0076	Cushman	
L3	Choke, 2 1/2 Turns Wide Band	1586-0003	VK	20020/4B
L4	Choke, 100μH, 5%	1585-0017	Delevan	1537-76
L5	Choke, 2 1/2 Turns Wide Band	1586-0003	VK	20020/4B
L6	Choke, 100μH, 5%	1585-0017	Delevan	1537-76
L7	Choke, 2 1/2 Turns Wide Band	1586-0003	VK	20020/4B
L8	Choke, 100μH, 5%	1585-0017	Delevan	1537-76
	TRANSISTORS			
Q1	Trans, 2N3904	1272-0032	Motorola	2N3904
Q2	Trans, 2N3904	1272-0032	Motorola	2N3904
Q3	Trans, 2N3904	1272-0032	Motorola	2N3904
Q4	Trans, 2N3904	1272-0032	Motorola	2N3904
Q5	Trans, 2N3904	1272-0032	Motorola	2N3904
	RESISTORS			
R1	Res, 3.3K, 5%, 1/4W Comp	1066-3325	Allen-Bradley	CB3325
R2	Res, 3.3K, 5%, 1/4W Comp	1066-3325	Allen-Bradley	CB3325
R3	Res, 1.8K, 5%, 1/4W Comp	1066-1825	Allen-Bradley	CB1825
R4	Res, 61.9 Ohm, 1%, 1/10W MF	1075-0007	Dale	MF 1/10
R5	Res, 255 Ohm, 1%, 1/8W MF	1075-0047	Dale	MF 1/8
R6	Res, 61.9 Ohm, 1%, 1/10W MF	1075-0007	Dale	MF 1/10
R7	Res, 3.3K, 5%, 1/4W Comp	1066-3325	Allen-Bradley	CB3325
R8	Res, 3.3K, 5%, 1/4W Comp	1066-3325	Allen-Bradley	CB3325
R9	Res, 3.3K, 5%, 1/4W Comp	1066-3325	Allen-Bradley	CB3325
R10	Res, 3.3K, 5%, 1/4W Comp	1066-3325	Allen-Bradley	CB3325
R11	Res, 1.8K, 5%, 1/4W Comp	1066-1825	Allen-Bradley	CB1825
R12	Res, 61.9 Ohm, 1%, 1/10W MF	1075-0007	Dale	MF 1/10
R13	Res, 255 Ohm, 1%, 1/8W MF	1075-0047	Dale	MF 1/8
R14	Res, 61.9 Ohm, 1%, 1/10W MF	1075-0007	Dale	MF 1/10
R15	Res, 3.3K, 5%, 1/4W Comp	1066-3325	Allen-Bradley	CB3325
R16	Res, 3.3K, 5%, 1/4W Comp	1066-3325	Allen-Bradley	CB3325
R17	Res, 150 Ohm, 5%, 1/4W Comp	1066-1515	Allen-Bradley	CB1515
R18	Res, 24 Ohm, 5%, 1/4W Comp	1066-2405	Allen-Bradley	CB2405
R19	Res, 150 Ohm, 5%, 1/4W Comp	1066-1515	Allen-Bradley	CB1515
R20	Res, 150 Ohm, 5%, 1/4W Comp	1066-1515	Allen-Bradley	CB1515
R21	Res, 36 Ohm, 5%, 1/4W Comp	1066-3605	Allen-Bradley	CB3605
R22	Res, 150 Ohm, 5%, 1/4W Comp	1066-1515	Allen-Bradley	CB1515
R23	Res, 82 Ohm, 5%, 1/4W Comp	1066-8205	Allen-Bradley	CB8205
R24	Res, 33 Ohm, 5%, 1/4W Comp	1066-3305	Allen-Bradley	CB3305
R25	Res, 82 Ohm, 5%, 1/4W Comp	1066-8205	Allen-Bradley	CB8205

OUTPUT ATTENUATOR. A20 (cont)

CKT. REF.	DESCRIPTION	CE STOCK NO.	MFR.	MFR. NO.
R26	Res, 1.2K, 5%, 1/4W Comp	1066-1225	Allen-Bradley	CB1225
R27	Res, 100 Ohm, 5%, 1/4W Comp	1066-1015	Allen-Bradley	CB1015
R28	Res, 1K, 5%, 1/4W Comp	1066-1025	Allen-Bradley	CB1025
R29	Res, 1.6K, 5%, 1/4W Comp	1066-1625	Allen-Bradley	CB1625
R30	Res, 100 Ohm, 5%, 1/4W Comp	1066-1015	Allen-Bradley	CB1015
R31	Not Used			
R32	Res, 15K, 5%, 1/4W Comp	1066-1535	Allen-Bradley	CB1535
R33	Res, 3.3K, 5%, 1/4W Comp	1066-3325	Allen-Bradley	CB3325
R34	Pot, 20K, 20%, 1/2W	1203-0055	Bourns	3339H-1-203
R35	Res, 4.3K, 5%, 1/4W Comp	1066-4325	Allen-Bradley	CB4325
R36	Res, 15K, 5%, 1/4W Comp	1066-1535	Allen-Bradley	CB1535
R37	Pot, 10K, 20%, 1/2W 4 Turn	1203-0061	Bourns	3339H-1-103
R38	Res, 1K, 5%, 1/4W Comp	1066-1025	Allen-Bradley	CB1025
R39	Res, 2K, 5%, 1/4W Comp	1066-2025	Allen-Bradley	CB2025
R40	Res, 15K, 5%, 1/4W Comp	1066-1535	Allen-Bradley	CB1535
R41	Res, 100 Ohm, 5%, 1/4W Comp	1066-1015	Allen-Bradley	CB1015
R42	Res, 10K, 5%, 1/4W Comp	1066-1035	Allen-Bradley	CB1035
R43	Res, 5.1K, 5%, 1/4W Comp	1066-5125	Allen-Bradley	CB5125
R44	Pot, 20K, 20%, 1/2W	1203-0055	Bourns	3339H-1-203
R45	Res, 100 Ohm, 5%, 1/4W Comp	1066-1015	Allen-Bradley	CB1015
R46	Res, 10K, 5%, 1/4W Comp	1066-1035	Allen-Bradley	CB1035
R47	Pot, 50K, 20%, 1/2W	1203-0059	Bourns	3339H-1-503
R48	Res, 1K, 5%, 1/4W Comp	1066-1025	Allen-Bradley	CB1025
R49	Pot, 10K, 20%, 1/2W 4 Turn	1203-0061	Bourns	3339H-1-103
R50	Res, 4.3K, 5%, 1/4W Comp	1066-4325	Allen-Bradley	CB4325
R51	Pot, 10K, 20%, 1/2W 4 Turn	1203-0061	Bourns	3339H-1-103
R52	Res, 10K, 5%, 1/4W Comp	1066-1035	Allen-Bradley	CB1035
R53	Res, 1K, 5%, 1/4W Comp	1066-1025	Allen-Bradley	CB1025
R54	Res, 4.3K, 5%, 1/4W Comp	1066-4325	Allen-Bradley	CB4325
R55	Pot, 10K, 20%, 1/2W 4 Turn	1203-0061	Bourns	3339H-1-103
R56	Res, 15K, 5%, 1/4W Comp	1066-1535	Allen-Bradley	CB1535
	INTEGRATED CIRCUITS			
U1	IC, ATF419-16 dB Gain	2025-0064	Amperex	ATF419
U2	IC, SN72741P	2025-0067	T.I.	SN72741P
	FUSE HOLDER			
XF1	Fuse Holder, Vert PCB Mtg Submin	1965-0014	Littelfuse	281005

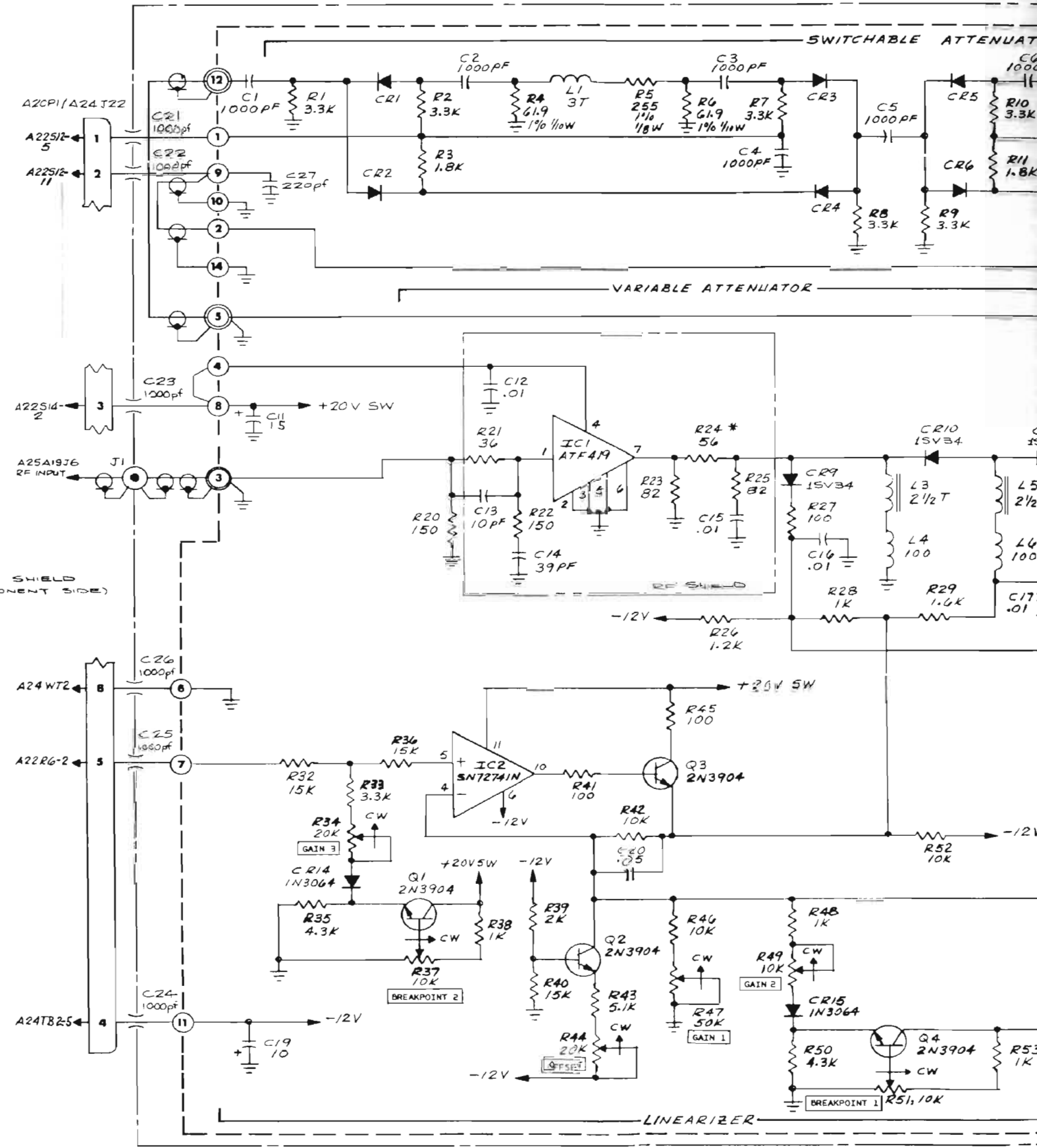
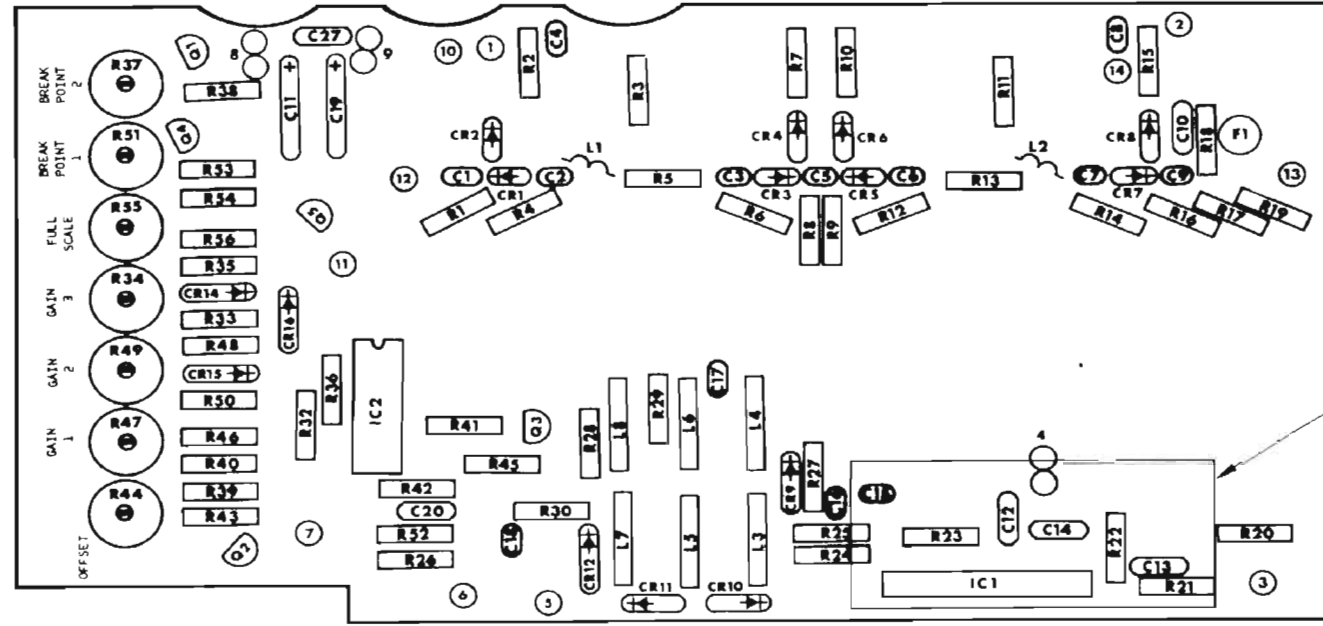

- NOTE:
1. RESISTORS - 1/4W, 5% VALUES IN OHMS UNLESS OTHERWISE NOTED.
 2. CAPACITORS - VALUES IN pF UNLESS OTHERWISE NOTED.
 3. INDUCTORS - VALUES IN μH UNLESS OTHERWISE NOTED.
 4. *FACTORY SELECT. TYPICAL VALUE SHOWN.
 5. ALL VOLTAGES ARE DC UNLESS OTHERWISE NOTED.
 6. ALL DIODES ARE MPN 3401 UNLESS OTHERWISE NOTED.

1000000000
BOTTOM VIEW

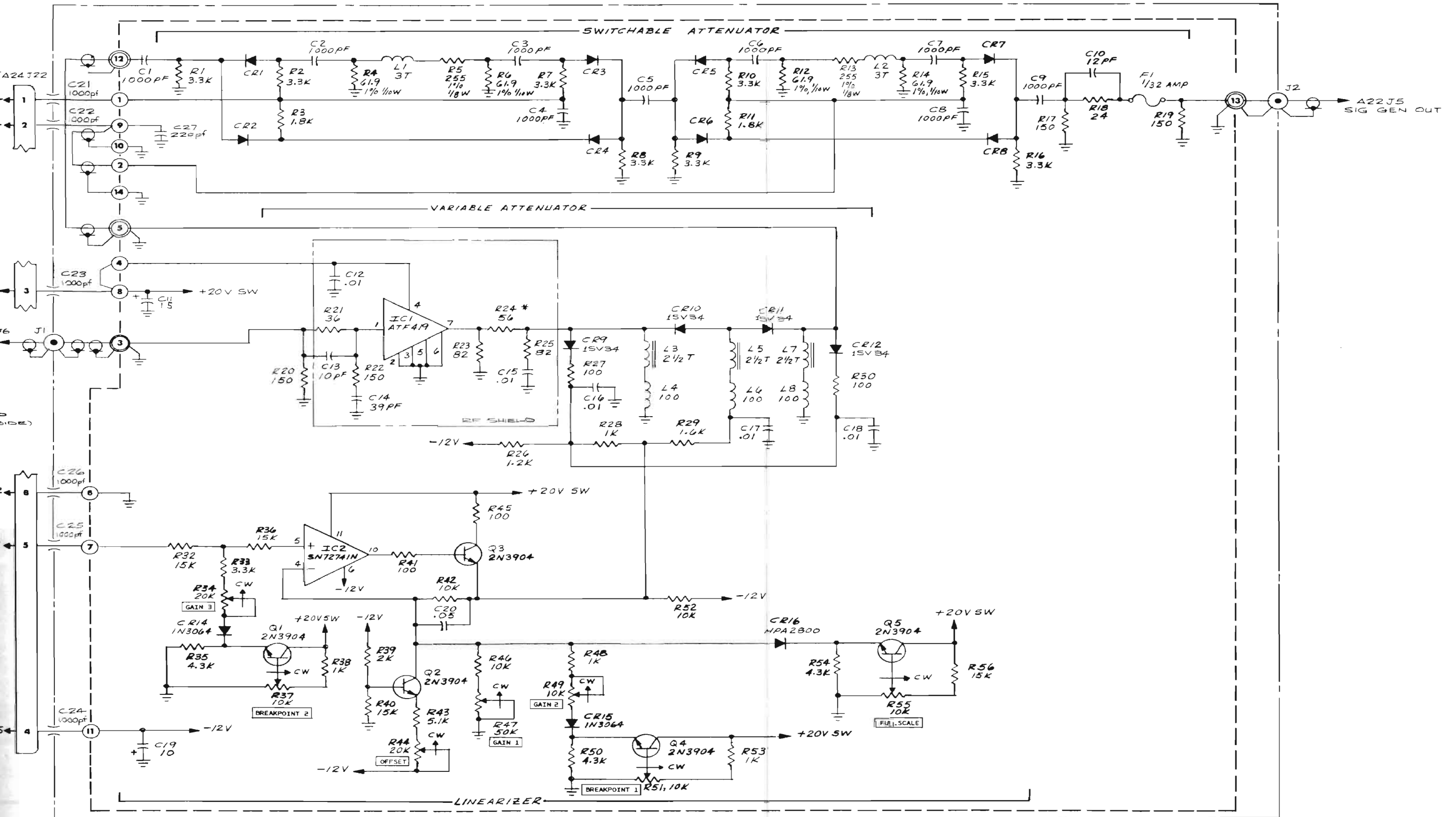

NOTE:
 1. RESISTORS - 1/8W, 5% VALUES IN OHMS UNLESS OTHERWISE NOTED.
 2. CAPACITORS - VALUES IN pF UNLESS OTHERWISE NOTED.
 3. INDUCTORS - VALUES IN μH UNLESS OTHERWISE NOTED.
 4. *FACTORY SELECT. TYPICAL VALUE SHOWN.
 5. ALL VOLTAGES ARE DC UNLESS OTHERWISE NOTED.
 6. ALL DIODES ARE MPN 3401 UNLESS OTHERWISE NOTED.



R31 & CR13 NOT USED

Figure 6-25. Output Attenuator. A20

DEAR CUSTOMER:

Every effort has been made to ensure the accuracy of this manual. If an error is discovered please notify us on the postpaid cards attached.

Please indicate where the error has been made. To improve future manuals your comments are requested.

CUSHMAN ELECTRONICS
PUBLICATIONS DEPARTMENT

There is an error on page _____/figure _____ of the _____
manual; _____

I would like to see these changes incorporated: _____

SIGNATURE _____

COMPANY _____

There is an error on page _____/figure _____ of the _____
manual; _____

I would like to see these changes incorporated: _____

SIGNATURE _____

COMPANY _____

BUSINESS REPLY MAIL

No Postage Stamp Necessary If Mailed In United States

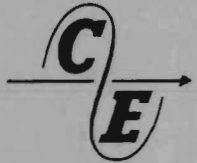

**CUSHMAN
ELECTRONICS, INC.**

830 Stewart Dr · Sunnyvale, CA 94086
Telephone: Area Code 408 - 739-6760

ATTN: PUBLICATIONS DEPT

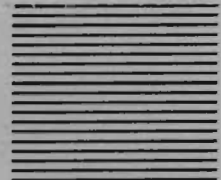

FIRST CLASS
PERMIT No. 176
SUNNYVALE, CA

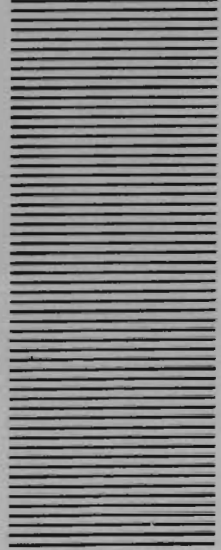

BUSINESS REPLY MAIL

No Postage Stamp Necessary If Mailed In United States

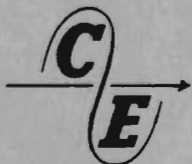

**CUSHMAN
ELECTRONICS, INC.**

830 Stewart Dr · Sunnyvale, CA 94086
Telephone: Area Code 408 - 739-6760

ATTN: PUBLICATIONS DEPT

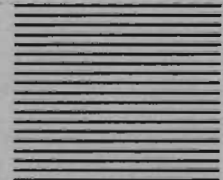

FIRST CLASS
PERMIT No. 176
SUNNYVALE, CA

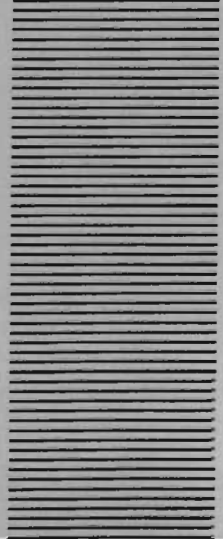

2450 North First Street San Jose, Ca 95131

Telephone: Area Code 408-263-8100