

# uniden®

## MRS 904

RX: 896 TO 901 MHZ  
TX: 935 TO 941 MHZ

---

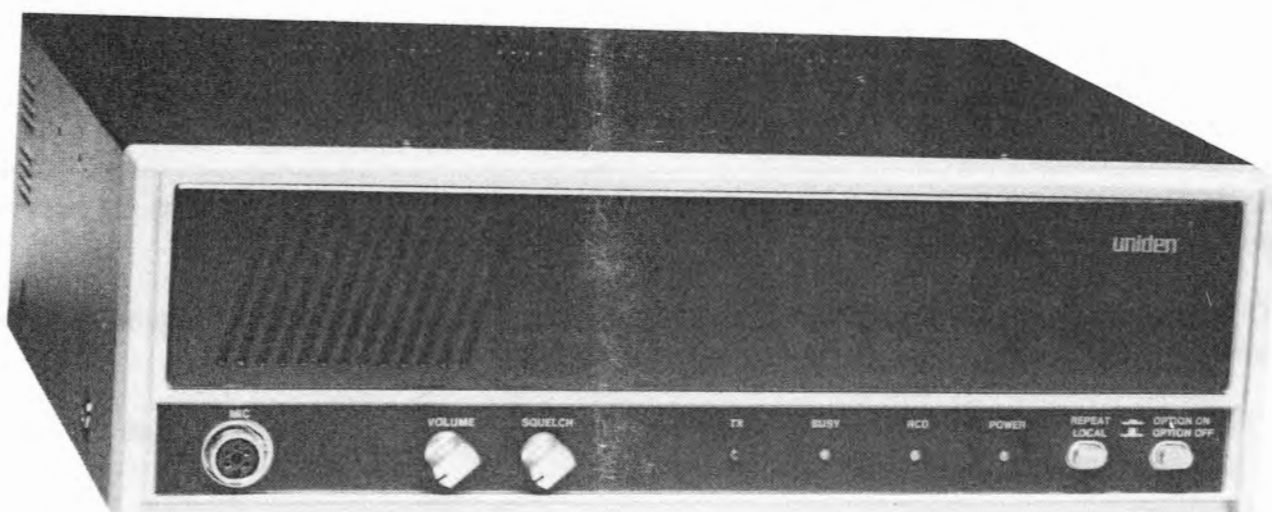

---

# uniden®

UNIDEN AMERICA CORPORATION  
Commercial Communications Division  
4700 Amon Carter Blvd.  
Fort Worth, TX 76155  
(817) 858-3300

CC SM 43

## SERVICE MANUAL

First Edition (January, 1990)

Uniden America Corporation reserves the right to make improvements and/or changes in the product(s) and/or component(s) described in this publication at any time. This publication could include technical inaccuracies or printing errors.

## SAFETY INFORMATION

Through the provisions of the Occupational Safety and Health Act (OSHA) of 1970, the United States Department of Labor has established an electromagnetic safety standard which applies to the use of two-way radio equipment. The proper use of this transceiver will result in exposure below the OSHA limit.

The following precautions shall be observed.:

### WARNING

**DO NOT** operate the transmitter of any radio equipment with the antenna touching, or close to the eyes, face, or exposed body parts.

**DO NOT** operate the transmitter of any radio equipment unless all the Radio Frequency (RF) connectors are secure and any open connectors are properly terminated.

**DO NOT** operate the transmitter of any radio equipment near electrical blasting caps or in an explosive atmosphere.

**DO NOT** let children operate any transmitter-equipped radio equipment.

Have your radio equipment installed and serviced by a qualified technician.

# MRS 904

## CONTENTS

ifc	Safety Information
3	Specifications
4	Introduction
7	Installation
7	Recommended Trunking System Layouts for Five and Ten Channels With Combiner
8	Repeater Network Data Link (RNDL) Bus
10	Cabling Instructions
13	Operation
13	Operating Controls and Indicators
13	Connectors
14	Repeater Operation
14	Local Control Operation
14	Local Control Operation (MRS 904S Conventional)
14	Theory of Operation
15	Basic Theory of Repeater Trunking
15	Design Concept
15	Trunking System Operation
15	Servicing Information
15	Disassembly
15	Suggested Test Equipment
16	MRS 904 Block Diagram
17	MRS 904T Trunking Mechanical Exploded View (Desk Top Version)
18	MRS 904S Conventional Mechanical Exploded View (Desk Top Version)
19	MRS 904TX Trunking Mechanical Exploded View (Slide Rack Mount Version)
20	MRS 904SXConventional Mechanical Exploded View (Slide Rack Mount Version)
21	Mechanical Exploded View (Internal)
22	Mechanical Exploded View (Receiver Module)
22	Mechanical Exploded View (Local Oscillator)
23	System Troubleshooting Flow Chart
24	Transmitter Troubleshooting Flow Chart
24	Receiver Troubleshooting Flow Chart
25	Logic Troubleshooting Flow Chart
26	Mechanical Parts List
29	Alignment Procedures
29	External DC Power Supply Adjustment
29	Local Audio and Squelch Adjustments
31	Transmitter Alignment Procedure
33	Trunking Logic Board (ARX 800A) Alignment Procedure
35	Conventional Control Board (PD-200AB) Alignment Procedure
36	Setting the DIP Switches
38	Repeater Test Mode
37	Frequency Setting
	Schematic Diagrams
48	Modifications to the ARX 800A Trunking Logic Controller
49	Motherboard (PD-388AB)
50	Receiver Module (PD-438AA)
51	Local Oscillator Module (PD-439AA)
52	RX PLL Module (PD-440AA)
52	Crystal Filter PCB (PD-458AA)
52	Second Mixer PCB (PD-377AA)
53	Switch PCB
53	Relay PCB
53	IF AMP PCB (PD-378AA)
53	LED PCB

- 54 Cable Harness Schematic
- 55 ARX 800A (MRS 904T Only) Logic Board (L-BOARD-1) Schematic (Page 1 of 2)
- 56 ARX 800A (MRS 904T Only) Logic Board (L-BOARD-1) Schematic (Page 2 of 2)
- 57 ARX 720 (MRS 904S Only) Conventional Logic Board (PD-200AB) Schematic
- Board Views
- 58 Local Oscillator Module (PD-439AA) X-Ray View, Component Side
- 59 Local Oscillator Module (PD-439AA) X-Ray View, Solder Side
- 60 Receiver Module (PD-438AA) X-Ray View, Component Side
- 61 Receiver Module (PD-438AA) X-Ray View, Solder Side
- 62 Motherboard (PD-388AB) X-Ray View, Component Side
- 63 Motherboard (PD-388AB) X-Ray View, Solder Side
- 64 ARX 720 (MRS 904S Only) Conventional Logic Board (PD-200AB) X-Ray View, Component Side
- 65 RX PLL Module (PD-440AA) X-Ray View, Component Side
- 66 RX PLL Module (PD-440AA) X-Ray View, Solder Side
- 67 Relay PCB X-Ray View, Component Side
- 67 Relay PCB X-Ray View, Solder Side
- 67 Crystal Filter PCB (PD-458AA) X-Ray View, Component Side
- 67 Crystal Filter PCB (PD-458AA) X-Ray View, Solder Side
- 68 LED PCB X-Ray View, Component Side
- 68 LED PCB X-Ray View, Solder Side
- 68 Second Mixer PCB (PD-377AA) X-Ray View, Component Side
- 68 Second Mixer PCB (PD-377AA) X-Ray View, Solder Side
- 69 Switch PCB X-Ray View, Component Side
- 69 Switch PCB X-Ray View, Solder Side
- 69 IF AMP PCB (PD-378AA) X-Ray View, Component Side
- 69 IF AMP PCB (PD-378AA) X-Ray View, Solder Side
- 70 ARX 800A (MRS 904T Only) Logic Board (L-BOARD-1) X-Ray View, Component Side
- 71 Cable Harness Mechanical View
- 72 Electrical Parts List
- 91 Installing the ARX 2940 Single High Stability Oscillator

# SPECIFICATIONS

The MRS 904 meets or exceeds the following specifications ( Conventional versions include 1 CTCSS tone and Trunking versions include the ARX 800A Logic Board):

---

<b>General</b>	<b>MRS 904</b>
Channels	one
Size	14.875" x 5.375" x 12.75" (380mm x 138mm x 327 mm)
Weight 20 lbs. (9.25kg)	
Input Power	
Primary	13.6 VDC (negative ground only)
Secondary	13.6 VDC (negative ground only)
Current Drain	
Transmit (Full Power)	1000 mA
Receive (Standby)	600 mA
Operating Temperature Range	-30°C to +60°C
Channel Spacing	12.5 kHz
Frequency Control	PLL
Frequency Resolution	12.5 kHz
Canadian DOC Approval	Pending

---

## **Transmitter - Conforms to EIA RS-152-B**

Frequency Range	935-941 MHz
RF Power Output	400 mW
Audio Distortion	3%
Modulation	11K0F3E, 11K0F9E
FM Hum & Noise	-40dB
Spurious & Harmonic Suppression	-40 dB
Frequency Stability	.05 ppm per Reference Input (ARX 2950)
FCC Transmitter Type Acceptance	Part 90 (AMW95P-89001)

---

## **Receiver - Conforms to EIA RS-204-B and C**

Frequency Range	896 - 901 MHz
Sensitivity	
12 dB SINAD	0.30 $\mu$ V
20 dB Quieting	0.40 $\mu$ V
Selectivity	70 dB
Intermodulation Rejection	70 dB
Spurious Rejection	80 dB
Image Rejection	70 dB
Modulation Acceptance	$\pm$ 3.75 kHz
Audio Output (@ 5% THD)	2.5 W
Frequency Stability	.05 ppm per Reference Input (ARX 2950)

---

Specifications are subject to change without notice.

# INTRODUCTION

## Scope of Manual

This service manual is intended for use by experienced technicians familiar with similar types of radios. It contains all service information required for the repeater described and is current as of the printing date. Changes which occur after the printing date are incorporated by Service Manual Revisions and/or Technical Service Bulletins. These Revision/Service Bulletins are added to the service manual as engineering changes are incorporated into the equipment.

## Technical Support

Technical assistance and information is available from the Commercial Communications Technical Support Group during normal work days between the hours of 8:00 am to 5:00 pm Central Time. The Commercial Communications Technical Support Group can be reached at:

Uniden America Corporation  
Commercial Communications Division  
Technical Support Group  
4700 Amon Carter Blvd.  
Ft. Worth, Texas 76155

Phone: 1-800-231-2868 (Outside of Texas)  
1-800-621-8527 (Inside Texas)  
1-817-858-3300  
FAX: 1-817-858-3528

### To return a unit for repair, send to:

Uniden America Corporation  
Commercial Communications Division  
Repair Department  
4700 Amon Carter Blvd.  
Fort Worth, TX 76155

Phone: 1-817-858-3638  
FAX: 1-817-858-3523

## Replacement Parts and Additional Manuals

Replacement parts are available through the Parts Department located in Fort Worth, Texas. When ordering replacement parts, please use the complete identification number of the part. If the identification number is not known, the order should contain the Part Symbol Number, Unit Model Number and a description of the part so that the part can be properly identified. Parts orders may be placed by writing to:

Uniden America Corporation  
Commercial Communications Division  
Parts Department  
4700 Amon Carter Blvd.  
Fort Worth, TX 76155

Phone: 1-817-858-3600  
FAX: 1-817-858-3523  
Telex: 27-2296

Additional copies of this manual are available through the Sales Department located in Fort Worth, Texas. When ordering please include the Part Symbol Number and the Unit Model Number. Mail service manual orders to:

Uniden America Corporation  
Commercial Communications Division

### Sales Department

4700 Amon Carter Blvd.  
Fort Worth, Texas 76155

Phone: 1-800-521-9627 (Outside of Texas)  
1-800-621-8527 (Inside Texas)  
1-817-838-3568  
FAX: 1-817-858-3523

### In Canada:

UNIDEN Canada Inc.  
11 Plateau Street  
Pointe Claire (Montreal), Quebec  
Canada H9R 9Z7

Phone: 1-514-697-6920  
FAX: 1-514-697-7700

## FAST ACCESS SYSTEM TRUNKING

The MRS 904T is a stand-alone, 400 mW, 900 MHz Trunking Repeater that supports the LTR signalling format. Fast Access System Trunking (FAST) is the latest advance in trunking system technology from Uniden. The FAST System delivers almost instantaneous transmission of voice communications as well as data, without the slow response and frequent busy signals associated with older trunking systems. A FAST System may have up to 20 individual channels. Each channel consists of an MRS 904T repeater, a linear amplifier, and a switching power supply. Figure 1 is a logic diagram of the FAST system.

A complete FAST System consists of the following elements:

- Antenna and antenna mounting system. You may mount the antenna on a tower or on a building using a bracket. Uniden does not supply antennas and antenna mounting systems.
- ARX 176 Post Combiner Filter.
- ARX 173 Transmitter Combiner.
- ARX 175 Receiver Multicoupler.
- MRS 904 Repeater.
- ARX 1600 Power Amplifier .
- ARX 310 Power Supply.
- ARX 2950 Master Oscillator
- Enclosed cabinets or open relay racks (ARX 430 or ARX 440).

In addition to the preceding elements you may add the following optional equipment:

- ARX 19X Transmitter Combiner, Receiver Multicouplers or Duplexer cable kits.
- ARX 780 Repeater Interconnect Controller (phone patch)
- ARX 800 Trunked Logic Controller (for overlay applications); an individual panel
- ARX 820 ID Validator
- ARX 850 Air Time Billing Package

There are three models of MRS 904 repeaters. Each model has a 400 mW output and is available in rack mount and desk top versions. The MRS 904S is a conventional repeater, the MRS 904T is a FAST Trunking Repeater, and the MRS 904A is an AmeriCom® compatible repeater. If the model number ends with an 'X' (MRS 904SX/MRS 904TX), it is the slide rack mount version. The slide rack mount version supplies easy access to all adjustments.

The ARX 800 is a separate panel that contains an ARX 800A PCB. The ARX 800A PCB also has a "L-BOARD-01" designation visible on the printed circuit board, however, the Part Number is ARX 800A.

This service manual contains basic data on the MRS 904 Repeater. A separate manual is provided for each option delivered with your FAST System.

Figure 1. Fast Access System Trunking Logic Diagram

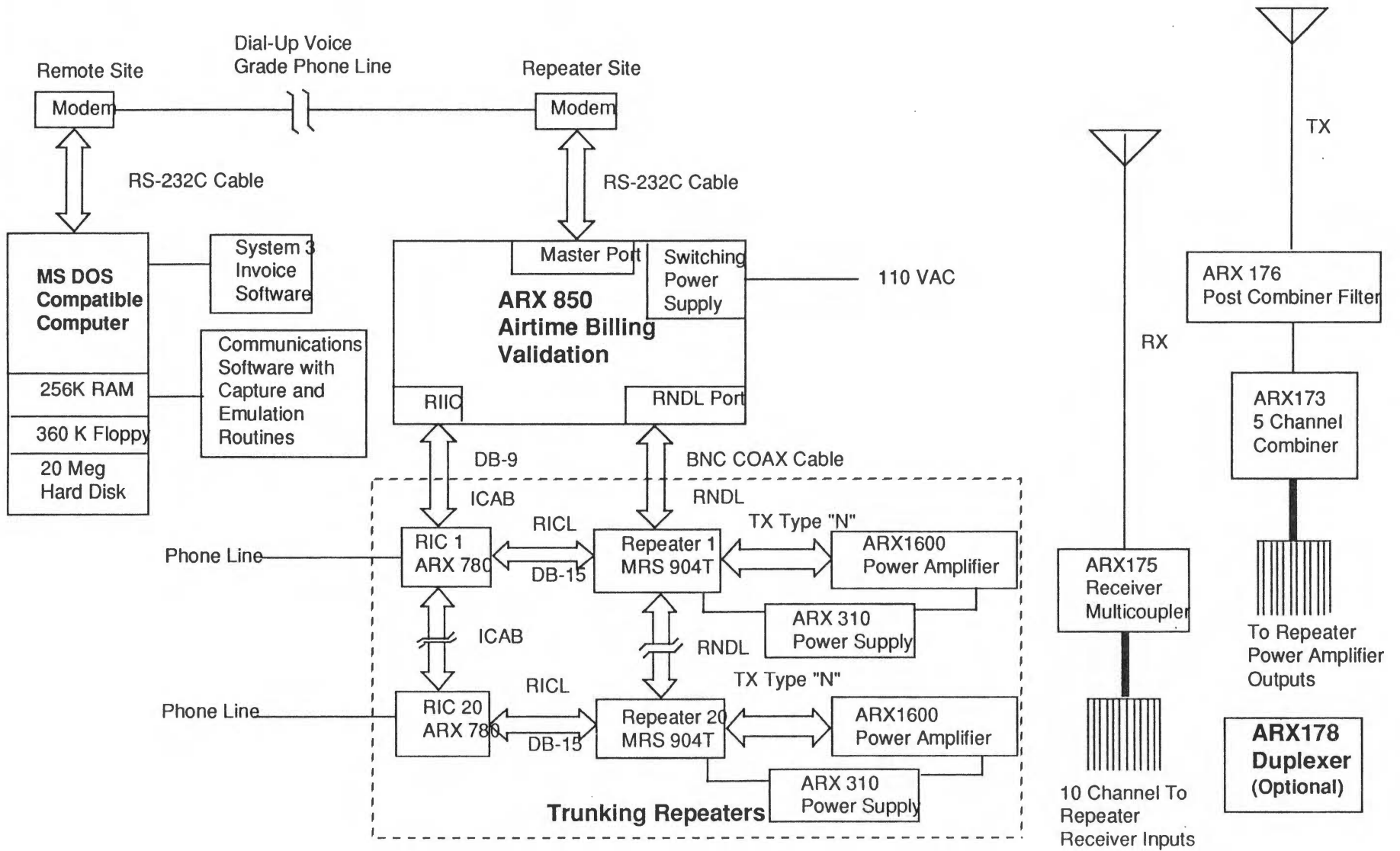



# INSTALLATION

The MRS 904T is available in a desk top or a slide rack mount version. You can place the deskmount version on any flat surface, such as a desk or a table. You can place the slide rack mount version in an ARX 430 cabinet (see figure 2) or an ARX 440 rack (see figure 3).

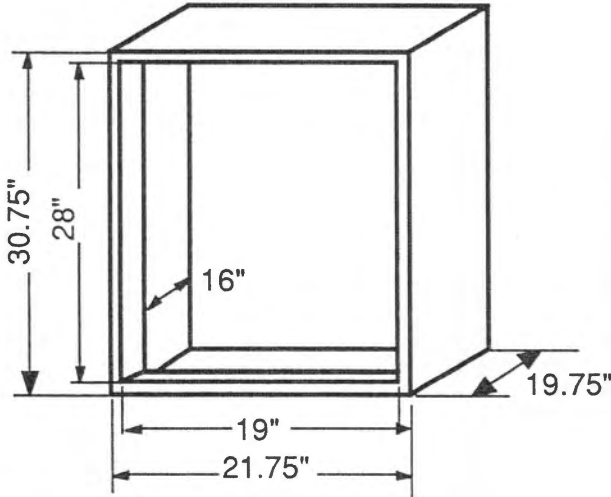

Figure 2. ARX 430 Cabinet

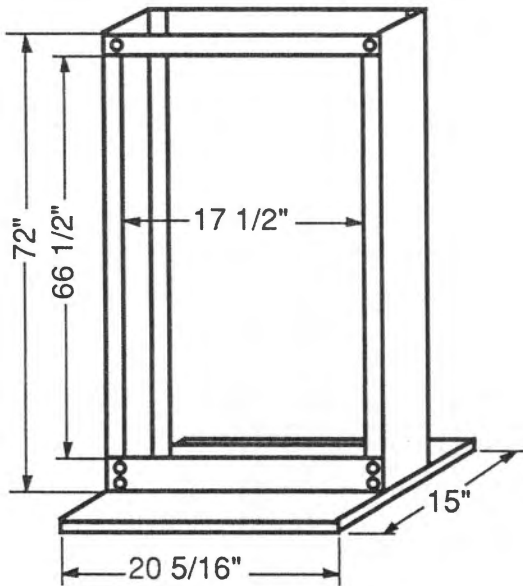

Figure 3. ARX 440 Rack

Table 1 shows the vertical height of some of the equipment that is typically placed in these cabinets.

Table 1. Equipment Heights

Device	Description	Size
ARX 173	Five Channel Combiner	10.5"
ARX 175	Ten Channel RX Multicoupler	3.5"
ARX 176	Post Combiner Filter	3.5"
ARX 178	High power Duplexer	3.5"
ARX310	Power Supply	5.25"
ARX 780	Telephone Interconnect	3.5"
ARX 800	Trunked Logic Controller	3.5"
ARX 820	Validator	3.5"
ARX 850	Air Time Billing	3.5"
ARX 1600	Power Amplifier	10.5"
MRS 904	900 MHz Repeater	5.25"
ARX 2950	Master Oscillator/Power Supply	3.5/ 5.25"

## RECOMMENDED TRUNKING SYSTEM LAYOUTS FOR FIVE AND TEN CHANNELS WITH COMBINER

Each channel in a trunking system is assigned a separate repeater. Each repeater in the recommended layouts consists of the following equipment:

- MRS 904T Trunking Repeater
- ARX 780 Telephone Interconnect
- ARX 1600 Power Amplifier
- ARX 310 Power Supply.

Each repeater is assigned a unique repeater number between 1 and 20. You select the repeater number by setting DIP switch S1 on the ARX 800A Logic PCB. See "Setting DIP Switches" for more information on how to set the repeater number. Space repeater numbers evenly and assign the highest repeater number to the lowest frequency.

Figure 4 shows a recommended five channel layout using ARX 440 racks. The lefthand and middle racks contain five repeaters. Each repeater consists of an MRS 904 repeater, an ARX 780 telephone interconnect, an ARX 310 power supply, and an ARX 1600 power amplifier. The righthand rack contains equipment that is used by all of the repeaters.

Figure 5 shows a recommended ten channel layout using ARX 440 racks. The lefthand and righthand racks contain ten repeaters. Each repeater consists of an MRS 904 repeater, an ARX 780 telephone interconnect, an ARX 310 power supply, and an ARX 1600 power amplifier. The middle rack contains equipment that is used by all of the repeaters.

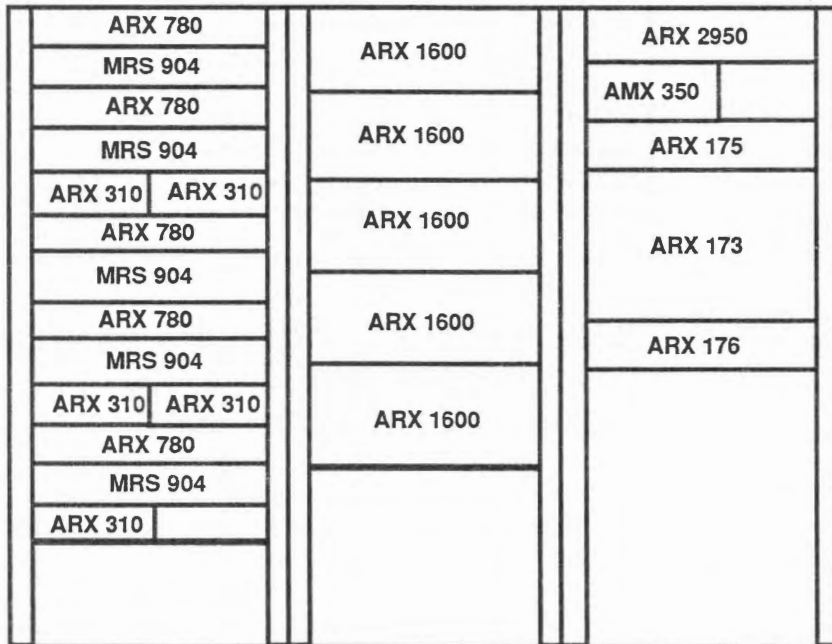

Figure 5. Recommended Ten Channel System Using ARX 440 Racks

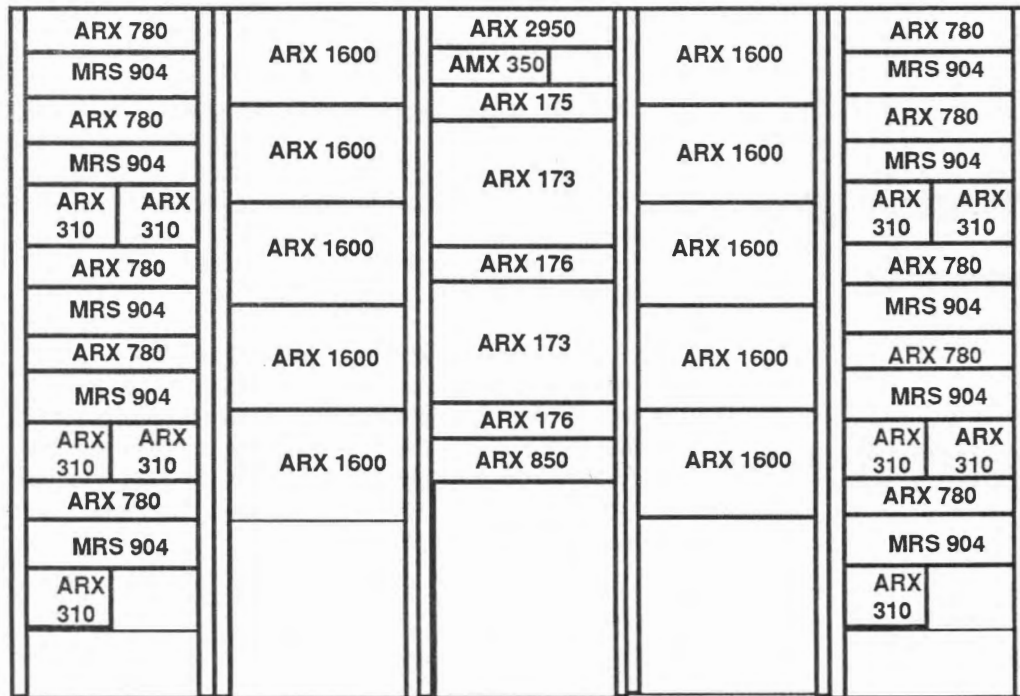

Figure 5. Recommended Ten Channel System Using ARX 440 Racks

## REPEATER NETWORK DATA LINK (RNDL) BUS

The Repeater Network Data Link (RNDL) bus connects the repeaters in the trunking system to each other and to the ARX 820 Validator or ARX 850 Air Time Billing option. Each end of the RNDL should contain a 100 ohm pull-up resistor. The 100 ohm pull-up resistor is built into the ARX 820 and the ARX 850. Therefore, if use an ARX 820 or ARX 850, place it at one end of the RNDL bus. If you have an MRS 904T at one or both ends of the RNDL bus, install a jumper between CN2-1 and CN2-4 on the Logic Board. Figure 6 shows an example of a RNDL bus for a three channel system with an ARX 820 or ARX 850.

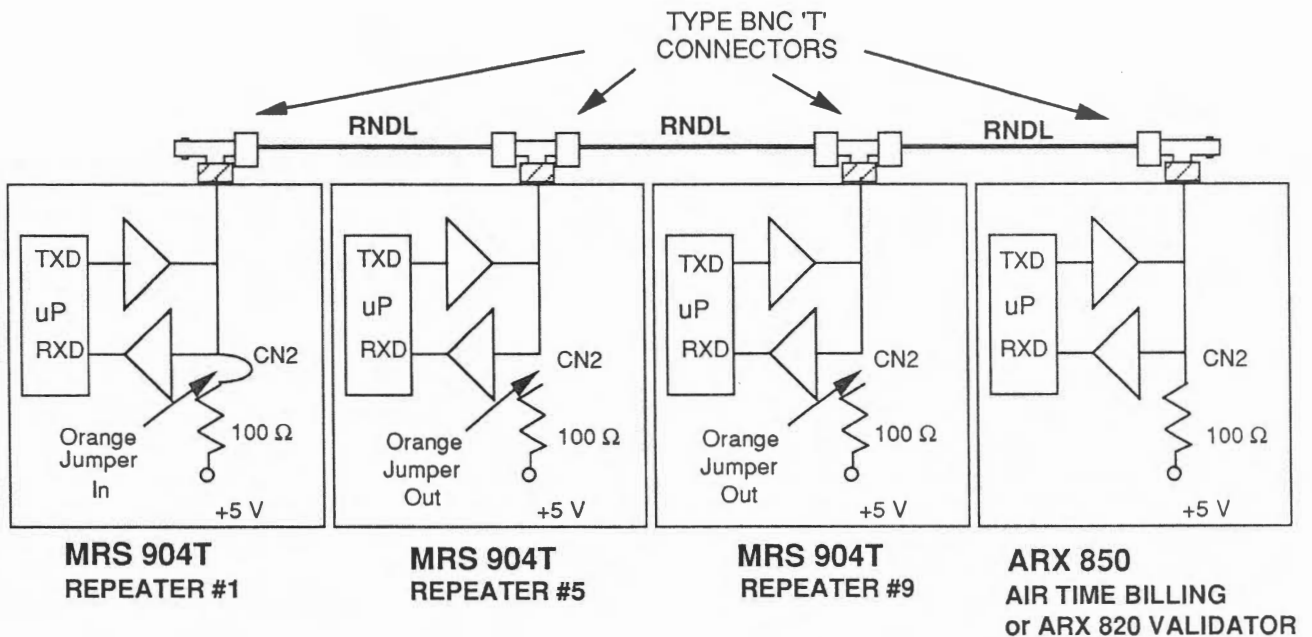

Figure 6. RNDL Bus for a Three Channel System with an ARX 820 or ARX 850

### NOTE

If the MRS 904 is the first or last device on the RNDL bus, you must install a jumper from CN2-1 to CN2-4.

## CABLING INSTRUCTIONS

Figure 7 describes the cabling for a typical trunking system. For information on how to cable a specific device, see the manual for that device. Cable each MRS 904 repeater in the trunking system as follows:

1. Install a type "N" T-connector in the receptacle marked "RNDL".
2. If the MRS 904 is not the first device on the RNDL bus, connect the cable from the last device on the RNDL bus to the T-connector.
3. If the MRS 904 is not the last device on the RNDL bus, connect a cable to the other side of the T-connector.
4. Install the receiver input cable in the "RX" receptacle.
5. Install a cable from the "TX" receptacle on the MRS 904 to the "RF IN" receptacle on the ARX 900 or the ARX 1500.
6. If you are using an ARX 780 Telephone Interconnect, install a cable from the "ACCESSORY" receptacle on the MRS 904 to the "REPEATER" receptacle on the ARX 780.
7. Install the cable from the 12V battery backup in the "BATTERY BACKUP" receptacle.

9. Install the cable from the ARX 310 power supply in the "DC INPUT" receptacle.
10. Repeat this procedure for each MRS 904 in the trunking system.

### KEY

<b>1</b> To J3 or J4 of ARX 780 via adapter cable	<b>9</b> Daisy Chained to Each MRS 904 Repeater	<b>17</b> MRS 904 13.8 VDC Input
<b>2</b> To MRS 904 RNDL	<b>10</b> ARX 1600 13.8 VDC Input	<b>18</b> To ARX 780 (15)
<b>3</b> J 3	<b>11</b> To Combiner (ARX 173)	<b>19</b> To ARX 2950
<b>4</b> J 4	<b>12</b> To Modem, Printer, or Terminal	<b>20</b> To MRS 904 Transmit Output
<b>5</b> To Telephone	<b>13</b> To MRS 904 (18pin)	<b>21</b> To MRS 904 and ARX1600 DC Inputs (17 and 10)
<b>6</b> To Telephone Line	<b>14</b> 110 VAC In	<b>22</b> DC Voltage Adjust
<b>7</b> Transmit Output Type "N" To ARX 1600 RF IN	<b>15</b> Power ON/OFF	
<b>8</b> Receiver Input Type "N"	<b>16</b> Backup Input 12V Battery	

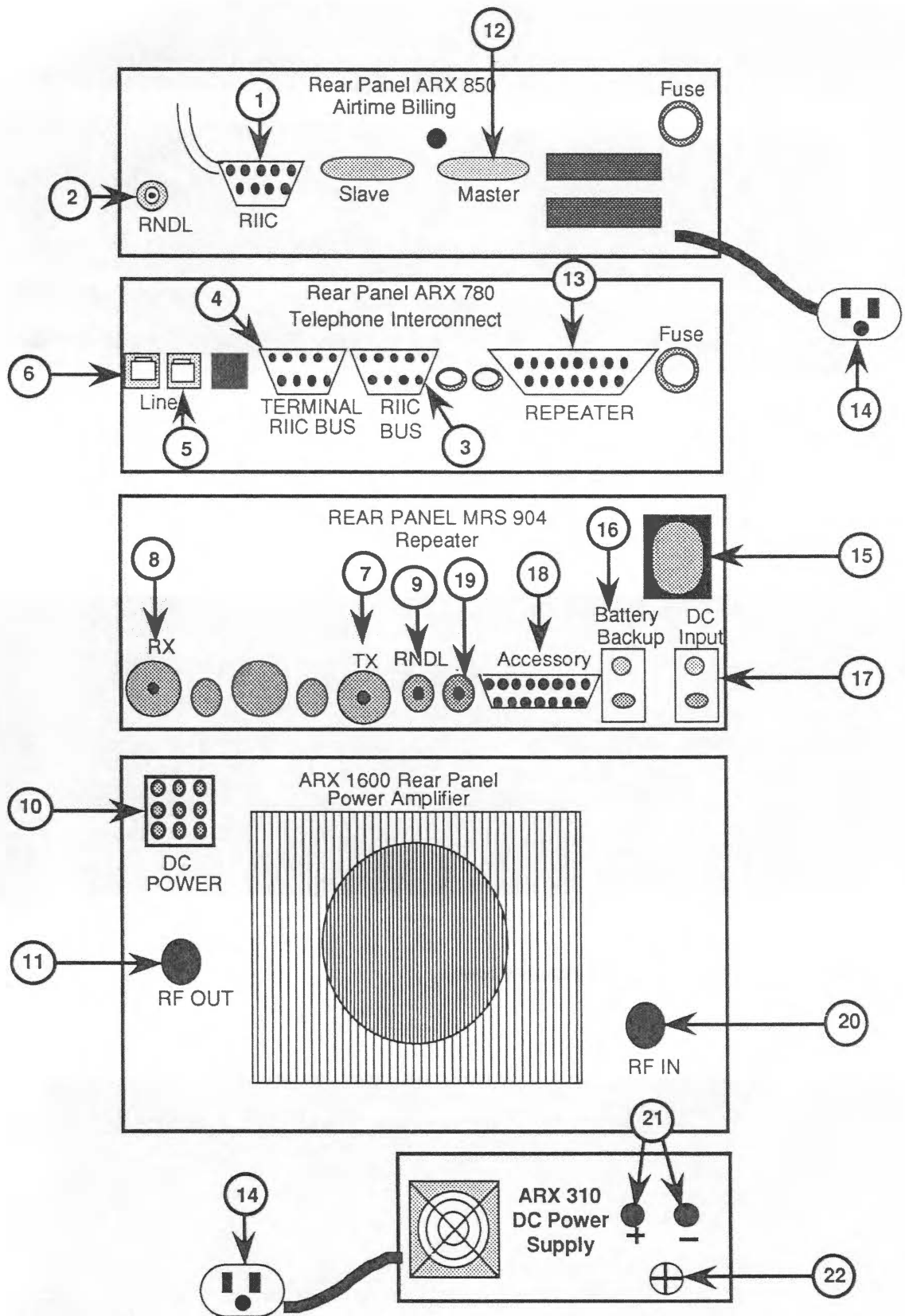

Figure 7. Cabling a Repeater

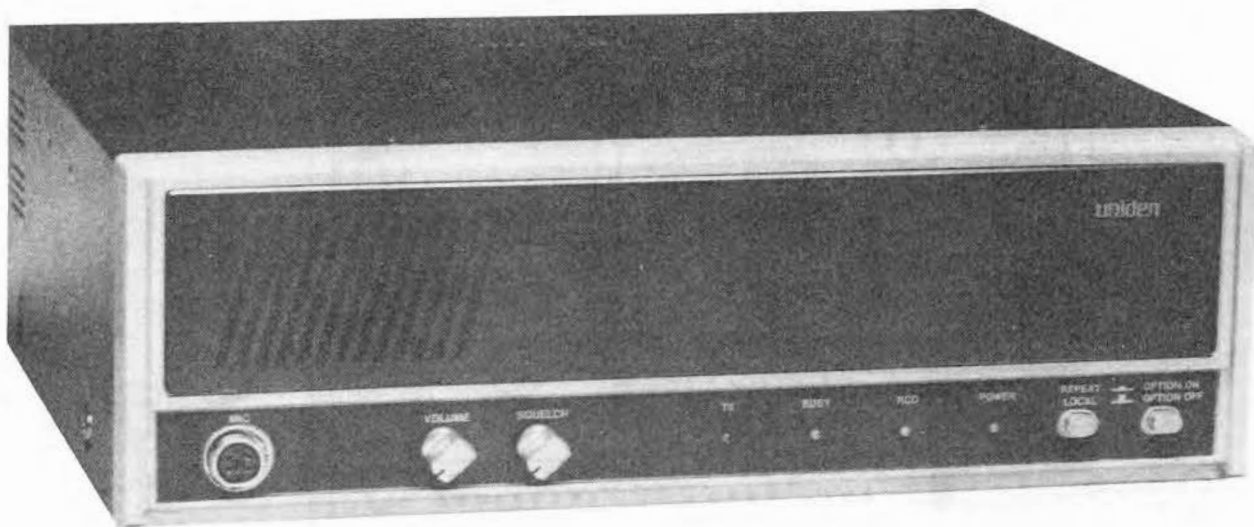

Figure 8. Front Panel Of MRS 904 Desk Top Version

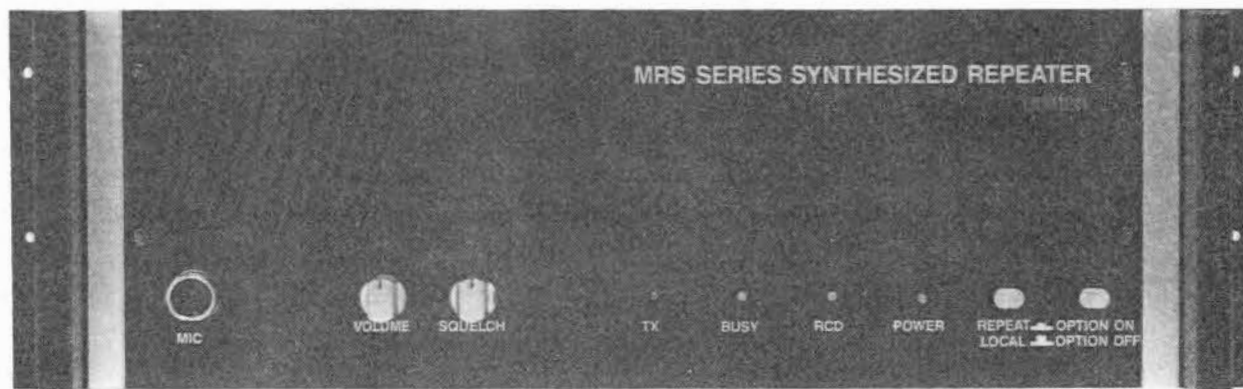

Figure 9. Front Panel Of MRS 904 Rack Mount Version

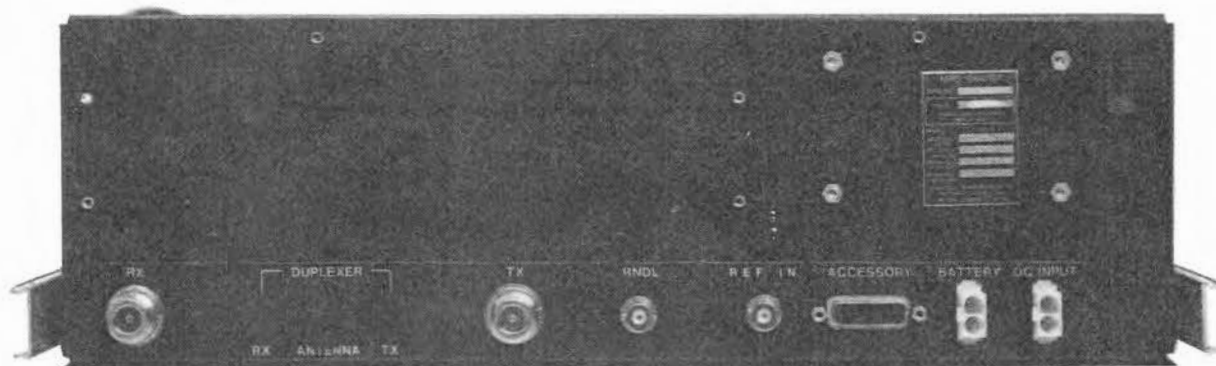

Figure 10. Rear Panel Of MRS 904

# OPERATION

## OPERATING CONTROLS AND INDICATORS

All of the operating controls and indicators, except the power switch, are located on the front panel (see figures 8 and 9).

**Power Switch** - The power switch is located on the rear panel. This switch turns the MRS 904 repeater on or off.

**POWER Light** - The POWER light glows steadily when the 13.6 VDC primary power is applied to the MRS 904 radio through the DC INPUT connector. This light flashes on and off when the backup 12.0 VDC power is applied through the BATTERY connector.

**SQUELCH CONTROL**- The SQUELCH control adjusts the Local Audio Amplifier opening sensitivity. Use the following procedure to adjust the squelch:

1. Rotate the SQUELCH control fully counterclockwise.
2. Rotate the SQUELCH control clockwise until the noise just disappears.
3. For the best results, leave the SQUELCH control in this position. Rotating the control further diminishes sensitivity.

### NOTE

The SQUELCH control has no effect on repeater operation.

**VOLUME Control** - Rotate the VOLUME control clockwise to increase the Local Speaker volume and counterclockwise to decrease the volume.

**REPEAT/LOCAL Switch** - When the switch is in the REPEAT position (depressed), the MRS 904 repeater action is automatic. Another station as well as the local microphone can access its transmitter. When the switch is in the LOCAL position (released), only the local microphone can access the transmitter of the MRS 904 repeater .

**RCD Light** - The yellow RCD (Received Data) Light comes on when the MRS 904T repeater properly decodes the subaudible trunking data that the mobile/portable radio generates. The microprocessor on the ARX 800A trunking logic controller board controls the RCD light. The RCD light must be On for the repeater to transmit, however it is normal for the RCD Light to "flicker" at times during marginal signal reception and multipath fading. This will not affect voice communications due to the two second repeater hang time.

**TX Light** - The TX (Transmit) light comes on when the MRS 904 transmitter is keyed.

**CALL Light** (MRS 904S Conventional) - If you use the MRS 904S repeater as a local control repeater/base station, the CALL light comes on and remain on when the repeater receives the correct CTCSS tone. The repeater must be equipped with the CTCSS option, the microphone must be in a properly grounded hang up bracket, and the MON/TONE SQ Switch must be in the TONE SQ position. To reset the CALL Light, remove the microphone from the hang up bracket or momentarily depress and release the MON/TONE SQ Switch.

**BUSY Light** - The BUSY light (LED) comes on to alert the user that the channel is busy when a carrier is present on the receive frequency.

**OPTION ON/OFF Switch** - When this switch is in the OPTION ON position (depressed), it has no effect on MRS 904 repeater operation. When this switch is in the OPTION OFF position (released), the MRS 904 repeater is keyed up for testing and alignment purposes.

**MON/TONE SQ Switch** (MRS 904S Conventional): When the switch is in the MON (monitor) position (depressed), the user can monitor or receive all calls transmitted on the channel. When the switch is in the TONE SQ (tone squelch) position (released), the user can receive only the transmissions intended for the user's group. The MRS 904S repeater must be equipped with the CTCSS option and the microphone must be hung up in a properly grounded hang up bracket.

## CONNECTORS

All of the connectors, except the microphone connector, are located on the rear panel (see figure 10).

**DC INPUT Connector** - Primary 13.6 VDC power input connector.

**BATTERY Connector** - Backup 12.0 VDC power input connector. The POWER Light flashes and warning tones are transmitted to alert the user when the MRS 904 is operating on backup power.

**ACCESSORY Connector** - The ACCESSORY Connector (Female 'D Subminiature' 15 Pin) is used to add the ARX 780 Telephone Interconnect with the MRS 904T (Trunking Version). It is also used to interface to AmeriCom® Network Switch in MRS 904A (AmeriCom® Version).

**RNDL Connector** - Connects the repeater to the Repeater Network Data Link (RNDL) Bus. See page 63 for recommended RNDL Bus connection

**MIC Jack:** The MIC (Microphone) jack connects the ARX 100A microphone to the MRS 904 repeater.

**TX Jack** - The TX (Transmitter) jack is a Type N Connector (400 mW) that connects the transmitter of the MRS 904 repeater to the antenna.

**RX Jack** - The RX (Receiver) jack is a Type N Connector that connects the antenna to the receiver of the MRS 904 repeater.

**Reference Input-** The reference input jack connects the TX and RX synthesizer of the repeater to the external reference oscillator (ARX 2950).

## REPEATER OPERATION

1. Set the POWER switch to on. Make sure that the green POWER Light glows steadily.
2. Rotate the SQUELCH control fully counterclockwise.
3. Rotate VOLUME control clockwise or counterclockwise to obtain the desired volume level.
4. Rotate the SQUELCH Control clockwise until the noise just disappears.
5. Place the REPEAT/LOCAL switch in the REPEAT (depressed) position.

## LOCAL CONTROL OPERATION

1. Perform steps 1 thru 4 of "Repeater Operation" above.
2. Place the REPEAT/LOCAL switch in the LOCAL (released) position.
3. \* Monitor channel to insure that it is not busy. Verify that the BUSY light is not on.
4. To transmit, depress and hold the Push-To-Talk (PTT) switch on the side of the microphone. Release the PTT Switch to end transmission.

5. Hang up the microphone.

\* MRS 904S Conventional only.

## LOCAL CONTROL OPERATION (MRS 904S Conventional)

1. Perform steps 1 thru 5 of "Local Control Operation" above.
2. You may use the MON/TONE SQ switch as follows:
  - a. With the switch in the MON position (depressed), the user can monitor or receive all calls transmitted on the channel.
  - b. With switch in TONE SQ position (released), the user can receive only the transmissions intended for the user's group. The MRS 904S repeater must be equipped with the CTCSS option and the microphone must be hung up in a properly grounded hang up bracket. The CALL Light will come on when you receive a call. To reset and turn off the CALL light, remove the microphone from the hang up bracket or momentarily depress and release the MON/TONE SQ switch.

## THEORY OF OPERATION

The MRS 904T Trunking Repeater is a full featured commercial grade trunking repeater. The standard model contains such features as CW Identifier, coded access, and provisions for automatic emergency power operation (battery). The MRS 904T attaches to the ARX 780 Telephone Interconnect for fully programmable interconnect. The MRS 904T also attaches to the ARX 850 Air Time Billing Package and the ARX 820 Validator.

The MRS 904T has a continuous duty rated output of 400 mW. It may be operated as a stand-alone repeater, but it is usually used with a Power Amplifier (ARX 1600) that boosts the power output to 150 W. This higher power output and the use of favorable installation sites permits very low power mobiles or portables to communicate over a greatly extended range. Combiners are available that allow a multi-channel repeater system to share a common antenna.



## BASIC THEORY OF REPEATER TRUNKING

Repeater trunking was designed to permit multiple users to equally and automatically share all channels. If a repeater is busy and the system has two or more repeaters, the incoming signal may be "handed off" to another repeater. This provides more rapid communication than with single repeater systems, where each call must be completed before another can be handled. Trunking systems are more convenient for the mobile/portable user who is no longer required to monitor the channel or adjust squelch. The user simply depresses the radio PTT switch to access a channel. Since the user cannot monitor a channel, trunking systems permit higher security in business communications.

The MRS series repeaters are completely compatible with all Uniden trunking radios. In these radios, each "system" setting is normally a different repeater site. This provides a wide area of coverage. The repeater retransmits the Group (digital) I.D. codes that trunking radios generate to provide private conversation.

## DESIGN CONCEPT

The design of the MRS 904T repeater system employs the module concept. The following table describes the modules and their location as a part of the system:

Module	Description	Location
Receiver	Full Shielded Plug-in	Plugs into Motherboard
Local Oscillator	Full Shielded Plug-in	Plugs into Motherboard
Mother board	PCB Sub Chassis	Mounts horizontally over Logic Board. You may raise Motherboard to vertical on hinged mounting for ease of service.
Logic Board	PCB	Mounted in cabinet base under Motherboard
DC relay	PCB	Mounted on back inside panel

## TRUNKING SYSTEM OPERATION

Mobile/portable radios are programmed to monitor one specific "home" channel in the trunking system. They monitor this channel at all times in the idle state. The mobile/portable radio receives subaudible data from the "home" channel. This subaudible data tells the radio that a call is coming in and steers the radio to the correct channel to receive the call. The mobile/portable radio also completes a "handshake" with the "home" channel every time the user depresses the radio PTT switch. If the "home" channel is not busy handling another call, the mobile/portable radio repeats on the "home" channel. If the "home" channel was busy when the user depressed the PTT switch, the mobile/portable radio "handshakes" with the next available repeater in the system.

All mobiles in the same group must be "homed" on the same channel. There are 250 (001-250) group I.D.'s per channel and up to 20 (01-20) channels per system. Therefore a 20 channel system has the capability of 5000 unique I.D.'s.

Each repeater uses the Repeater Network Data Link (RNDL) bus to communicate with the other repeaters in the system. The RNDL bus is a high speed serial data bus that communicates information regarding the repeater state (idle, busy) and the mobile I.D. A block diagram of the RNDL bus is included on page xx. A 100 Ohm pull-up resistor must be located at the first and last device on the RNDL. To provide these pull-up resistors in an MRS 904 repeater, install a jumper from CN2-1 to CN2-4. The pull-up resistor is already installed in the ARX 850 Air Time Billing Unit and ARX 820 Validator.

The MRS 904T repeater uses broad band technology to cover the following frequency ranges without retuning:

- Transmit - 935 to 941 MHz
- Receive - 896 to 901 MHz

There are 400 channels available to the repeater. These channels are spaced 12.5 kHz apart.

## SERVICING INFORMATION

### DISASSEMBLY

1. Place the MRS 904 unit on a flat static-free work surface.
2. Remove the eight screws that secure the top cover. There are two on each side, two on the top, and two on the rear.
3. Loosen the two captive slotted screws on the sub-chassis. You can now lift the sub-chassis on hinges to a vertical position. This allows access to the Logic/Controller Board and the Mother Board.
4. To achieve bottom access, remove the eight screws on the bottom panel. Secure the sub-chassis before you turn the unit over to access the bottom panel.

### SUGGESTED TEST EQUIPMENT

Table 3 shows the test equipment needed to repair this unit. A service monitor will replace many of the individual items.

Table 3. Suggested Test Equipment

TEST INSTRUMENT	REQUIRED SPECIFICATIONS	SUGGESTED TYPE or Equivalent
DC Power Supply	Voltage: 13.6 VDC Current: 8 Amperes Continuous	Ratelco PS-9 12 VDC Battery
RF Wattmeter	Frequency: 935-941 MHz Power: 0-1 Watts	Bird Model 43 with 50E Element
RF Dummy Load	Impedance: 50 Ohms Power: 50 Watts	Bird Model 8085 Bird Model 8135
DC Voltmeter	Range: 0-20 VDC DC Resistance: 10 Meg Ohm	Simpson 260 Fluke D802 or D804
AC Voltmeter	Range: 3 mV-20V AC	Leader LMV 181 A
Audio Generator	Frequency: 10 Hz-10 kHz Level: 0-1V	Leader LGA 120 A
Deviation Meter	Range: 0-5 kHz	Marconi TF 2304
Distortion Meter or Sinadder	Range: 30 Hz-10 kHz Level: 1 mV-300 V Input Level: 1-5 VAC	Leader LDM 170 Helper's Sinadder 3
RF Frequency Counter	Range: 1.3 GHz Accuracy: +.001 ppm/yr.	HP-5325B OPT 010, 030
Oscilloscope	Bandwidth: 50-100 MHz Triggered Sweep	Tektronix 2213 Tektronix 465B Hameg HM705
RF Signal Generator	Range: 800-910 MHz Level: 0.1-1000 uV Modulation: Int/Ext Deviation: 0-5 kHz	HP 8640 HP 8642
Attenuator	Attenuation: 20 dB Power: 50 Watts Minimum	Bird 8341-200 Bird 8343-200
FM Linear Detector Service Monitor		Cushman CE-50 or Cushman CE-4000 IFR 1200S or IFR 1500 Motorola RS2001 Wavetek 3000

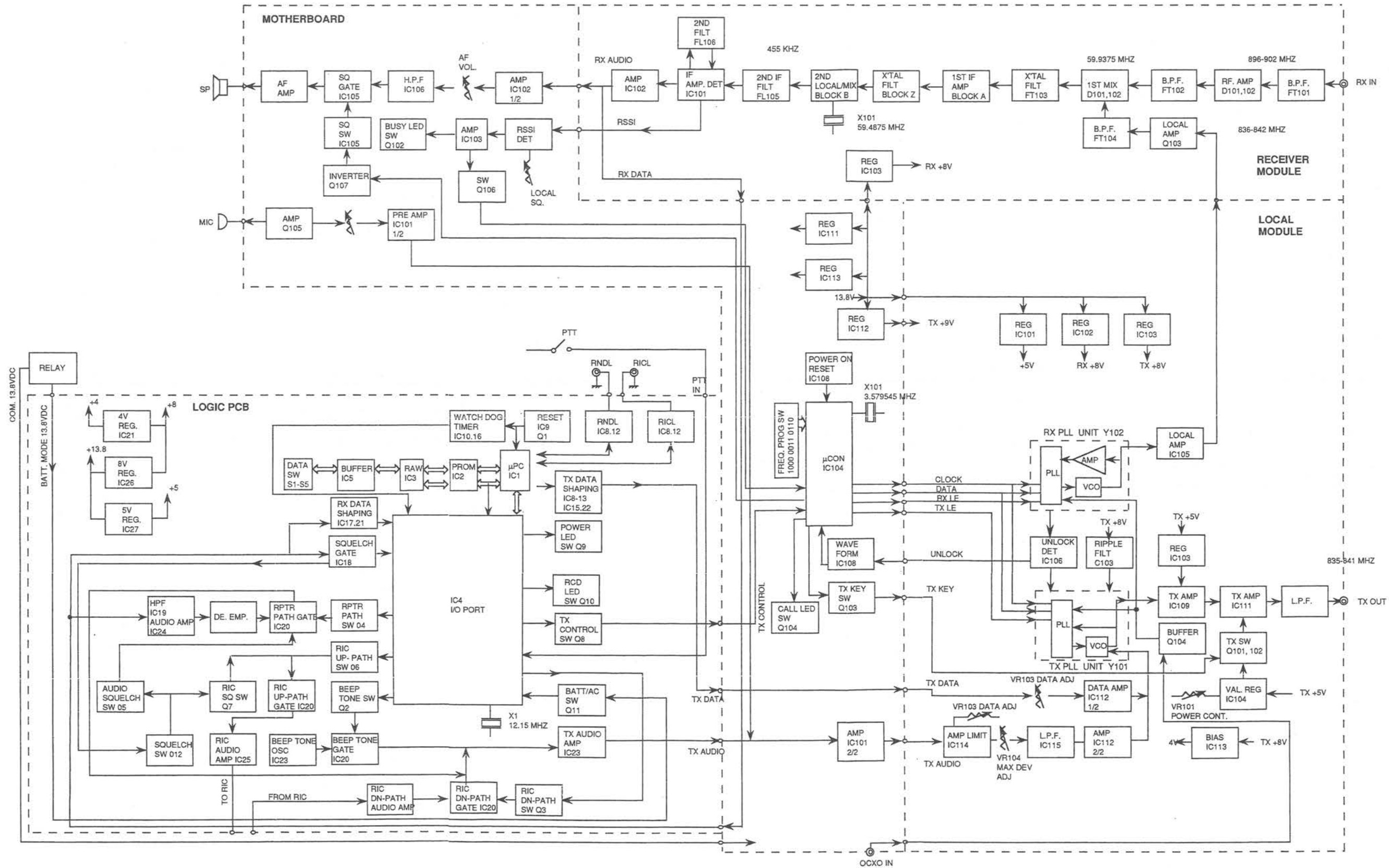

MRS 904  
BLOCK DIAGRAM

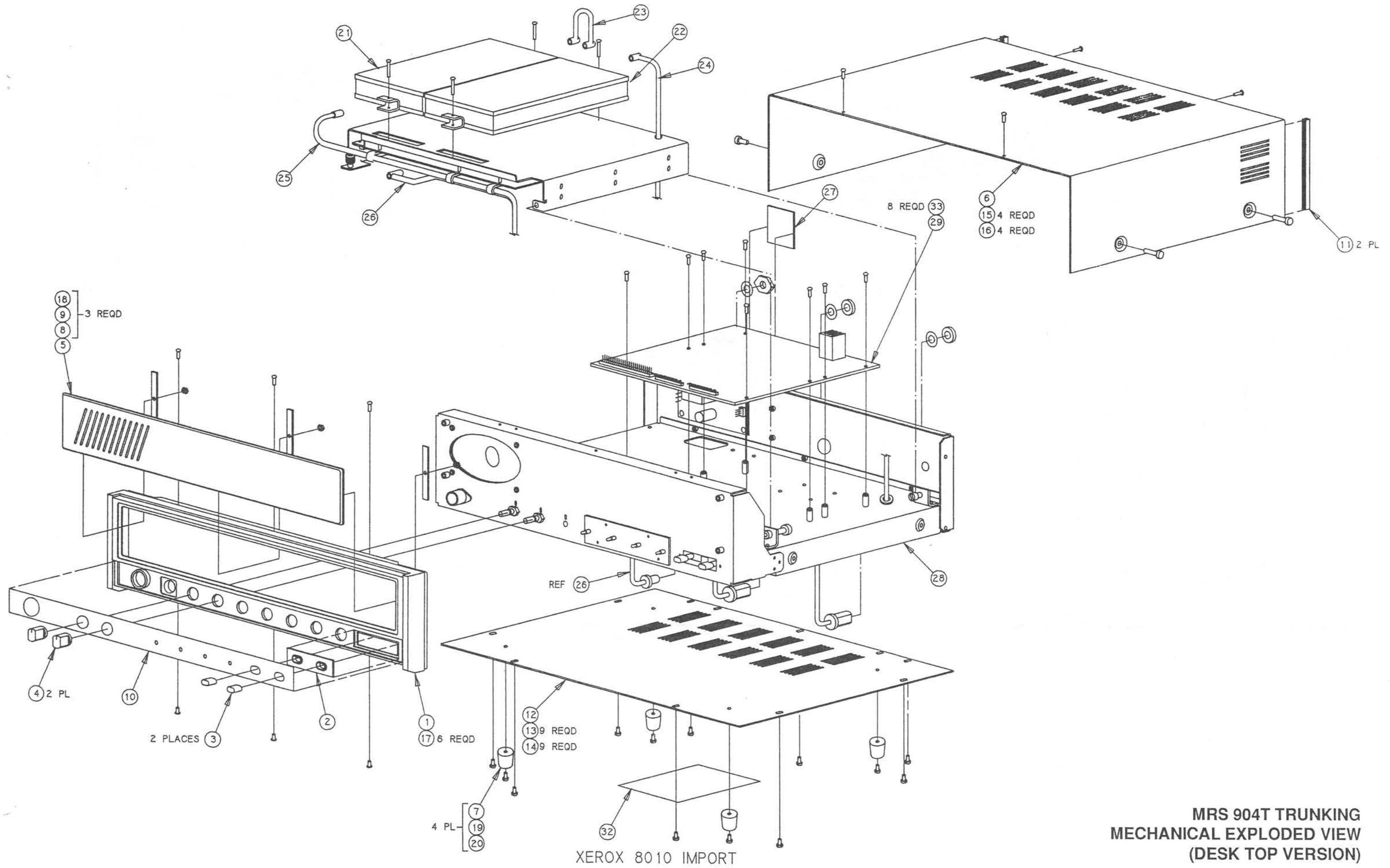

MRS 904T TRUNKING  
MECHANICAL EXPLODED VIEW  
(DESK TOP VERSION)

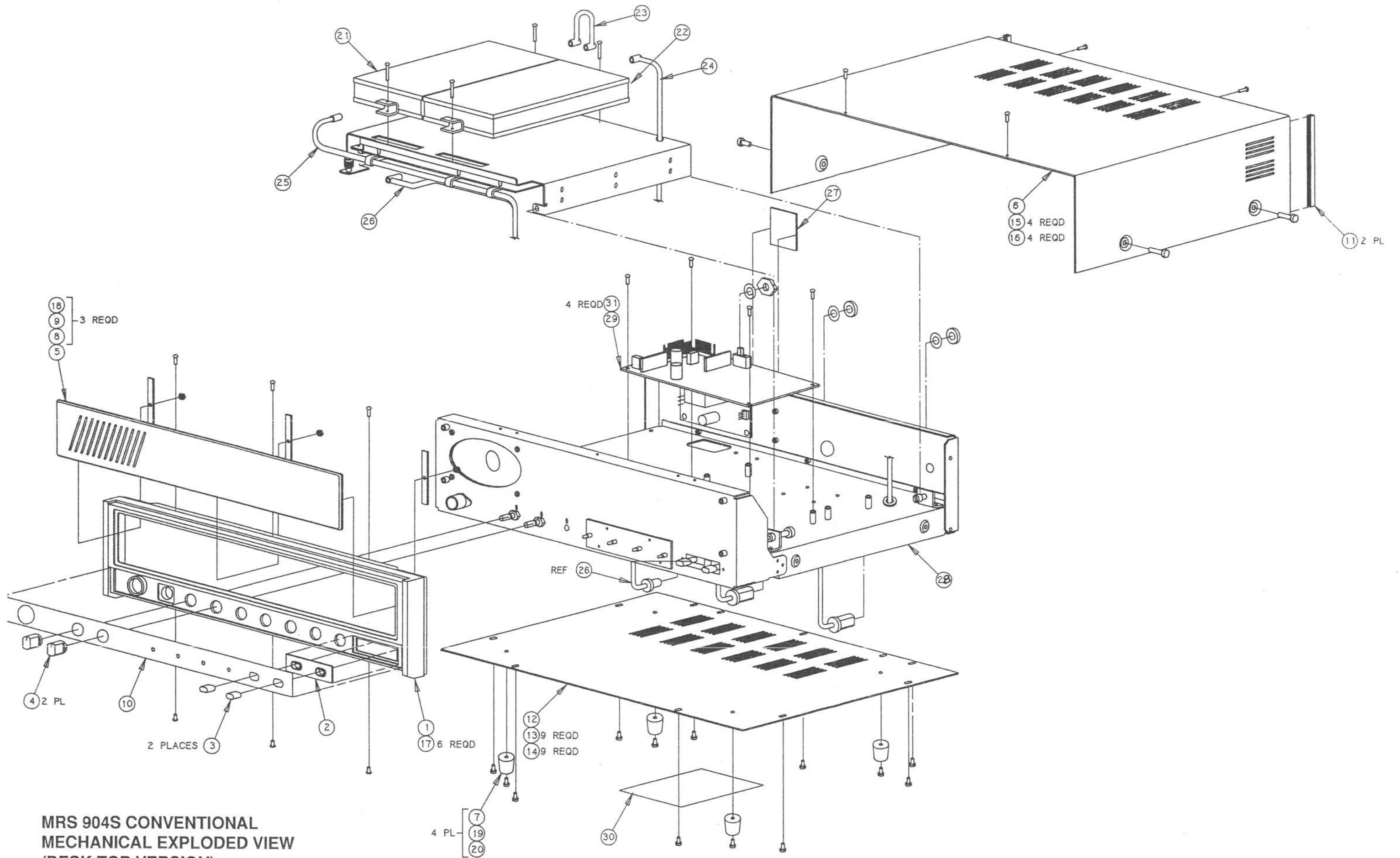

MRS 904S CONVENTIONAL  
MECHANICAL EXPLODED VIEW  
(DESK TOP VERSION)

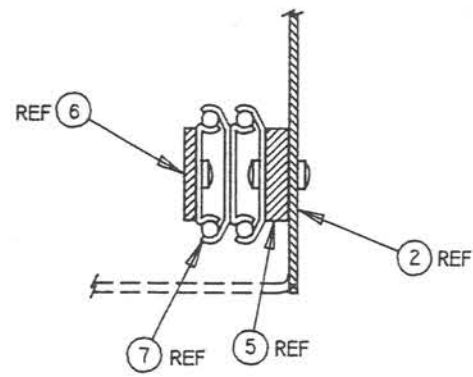

SECTION A-A  
 SCALE: 1:1  
 1 PLACE AS SHOWN  
 1 PLACE OPPOSITE HAND

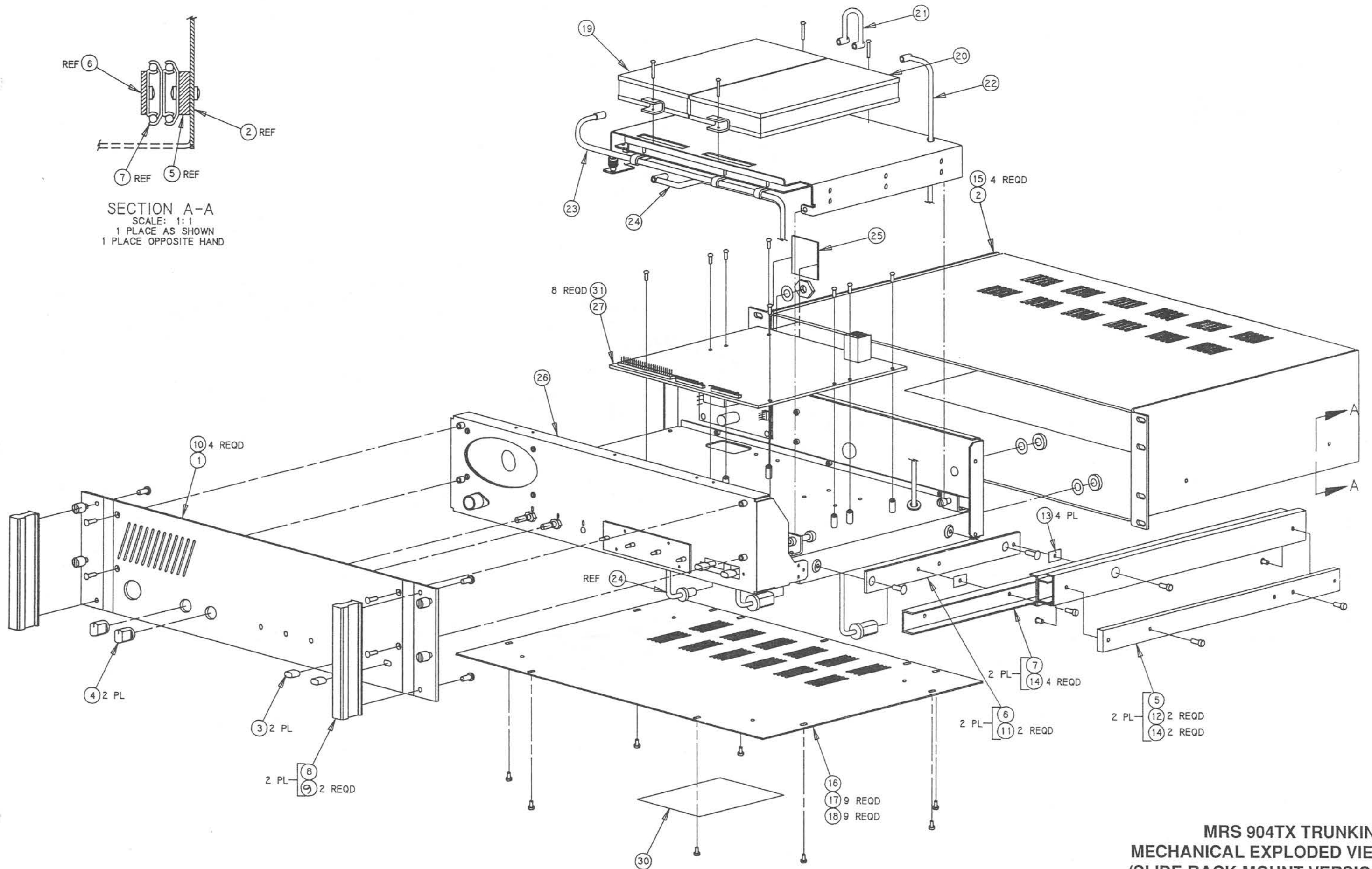

MRS 904TX TRUNKING  
 MECHANICAL EXPLODED VIEW  
 (SLIDE RACK MOUNT VERSION)

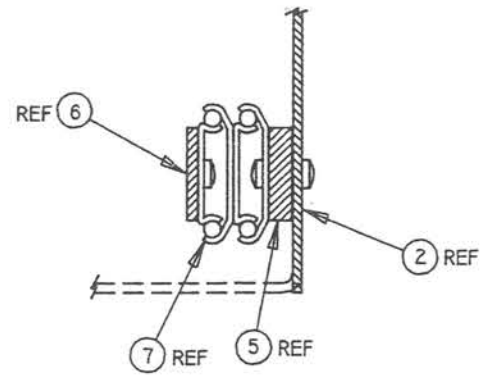

SECTION A-A  
SCALE: 1:1  
1 PLACE AS SHOWN  
1 PLACE OPPOSITE HAND

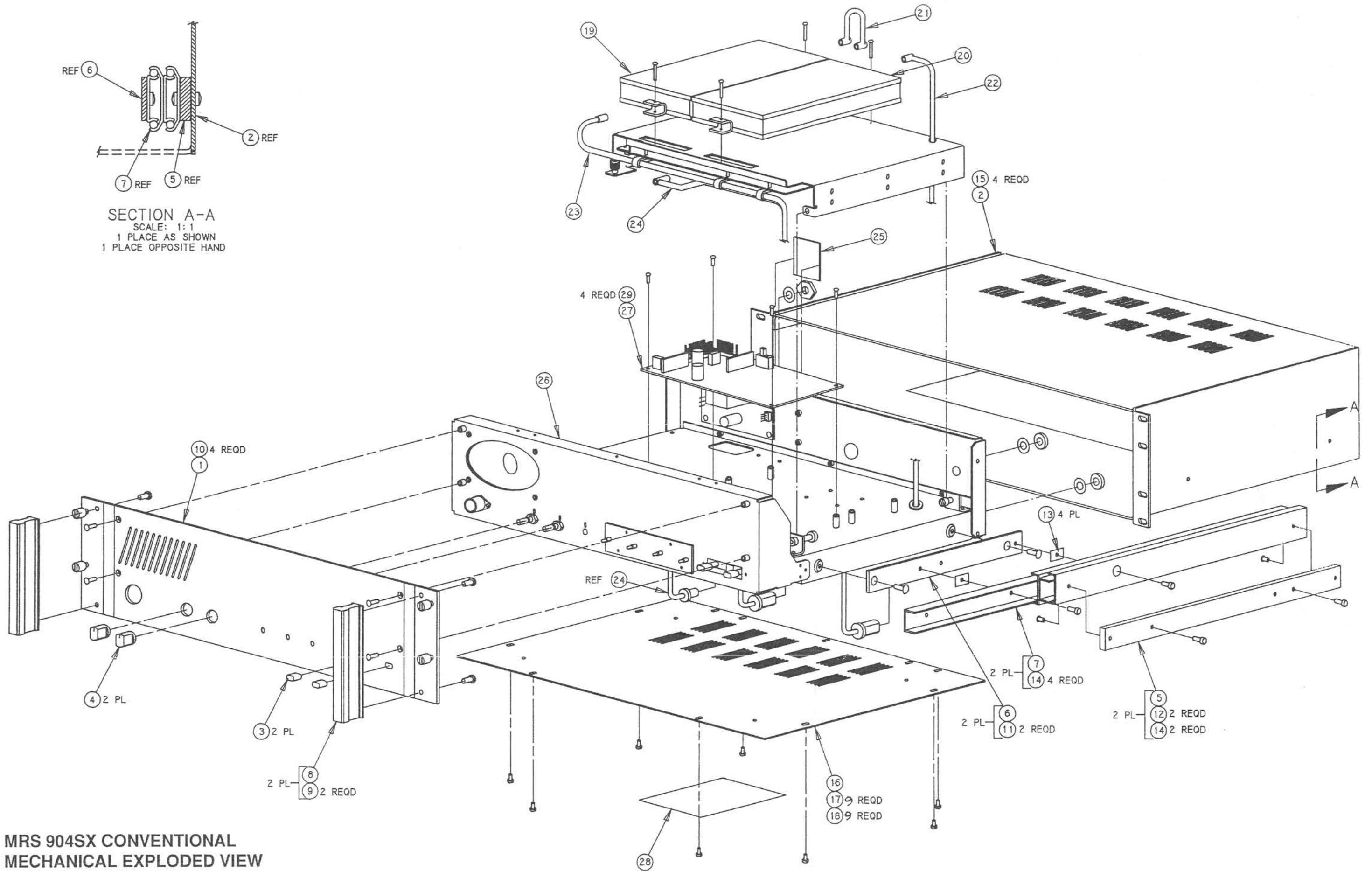

MRS 904SX CONVENTIONAL  
MECHANICAL EXPLODED VIEW  
(SLIDE RACK MOUNT VERSION)

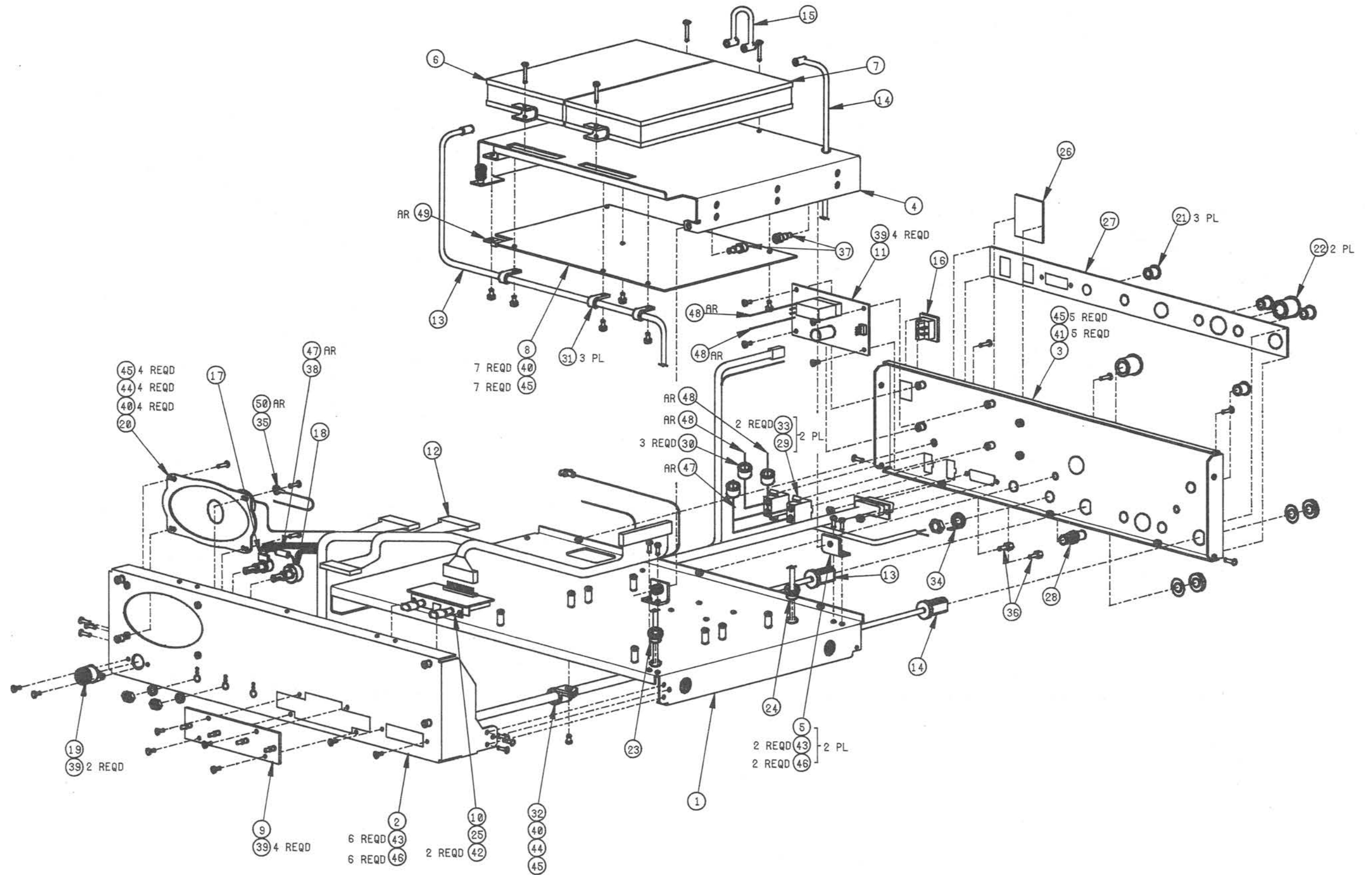

MRS 904  
 MECHANICAL EXPLODED VIEW  
 (INTERNAL)

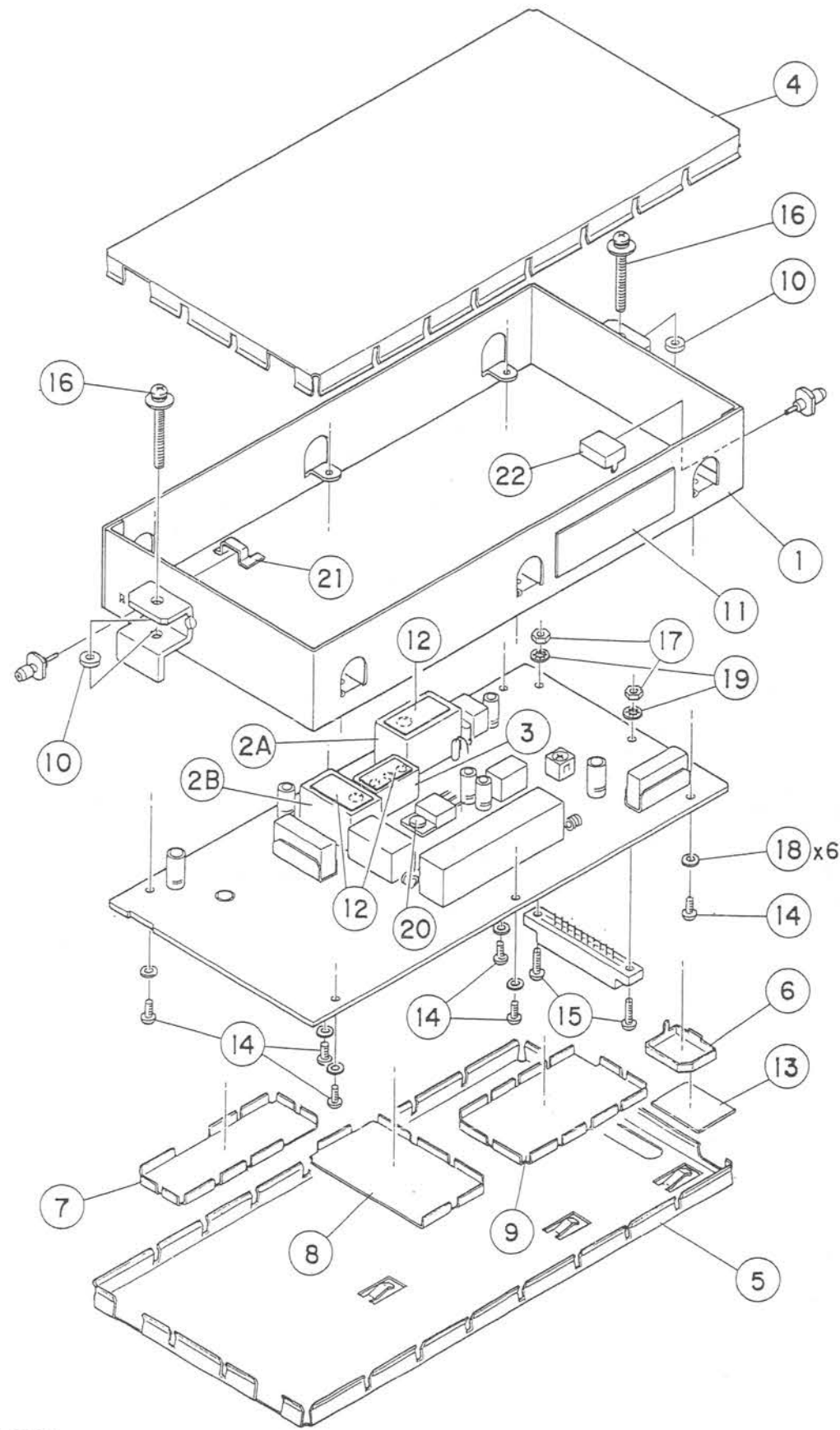

MRS 904  
RECEIVER MODULE  
MECHANICAL EXPLODED VIEW

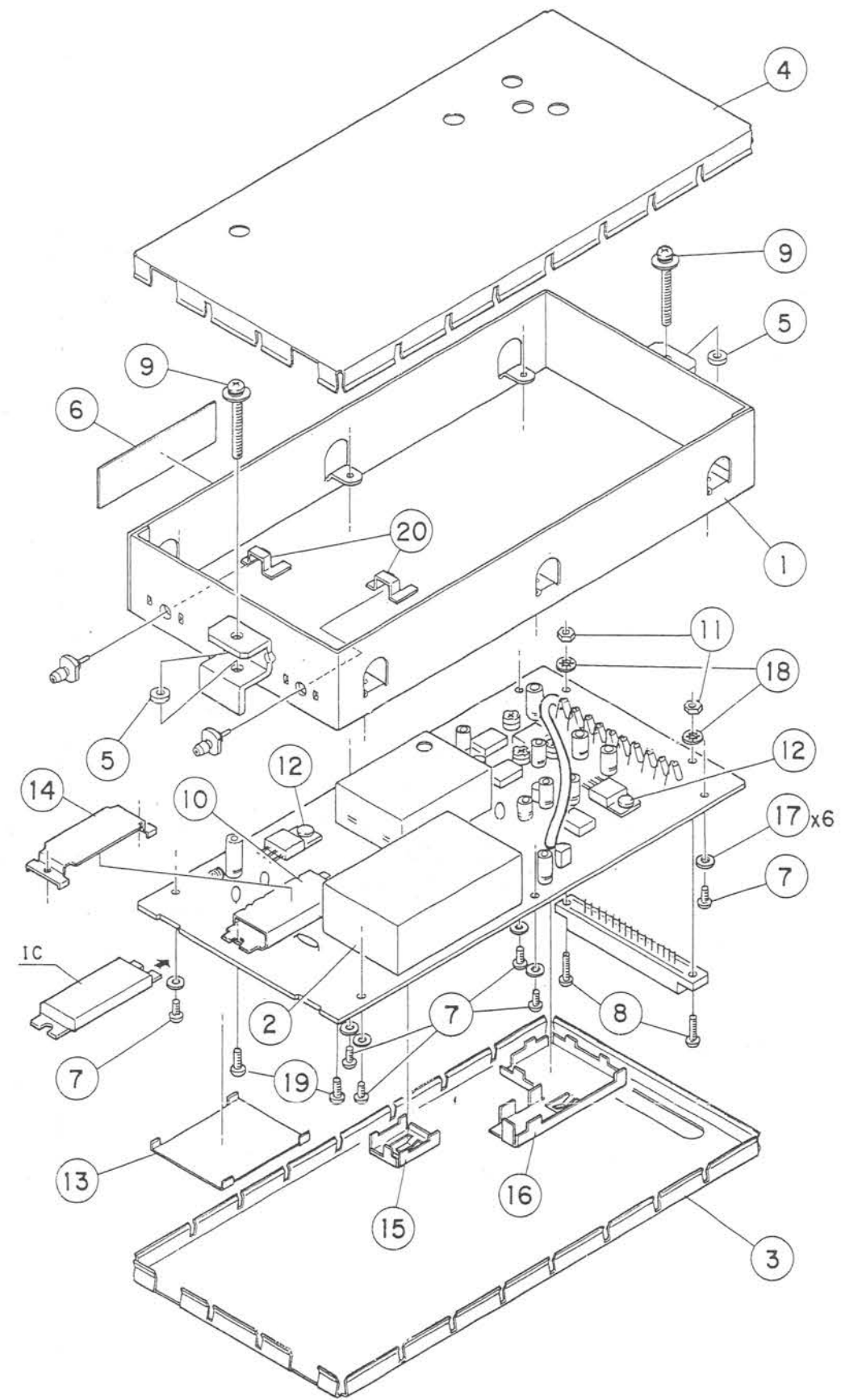

MRS 904  
LOCAL OSCILLATOR MODULE  
MECHANICAL EXPLODED VIEW



MRS 904 SYSTEM  
TROUBLESHOOTING  
FLOW CHART

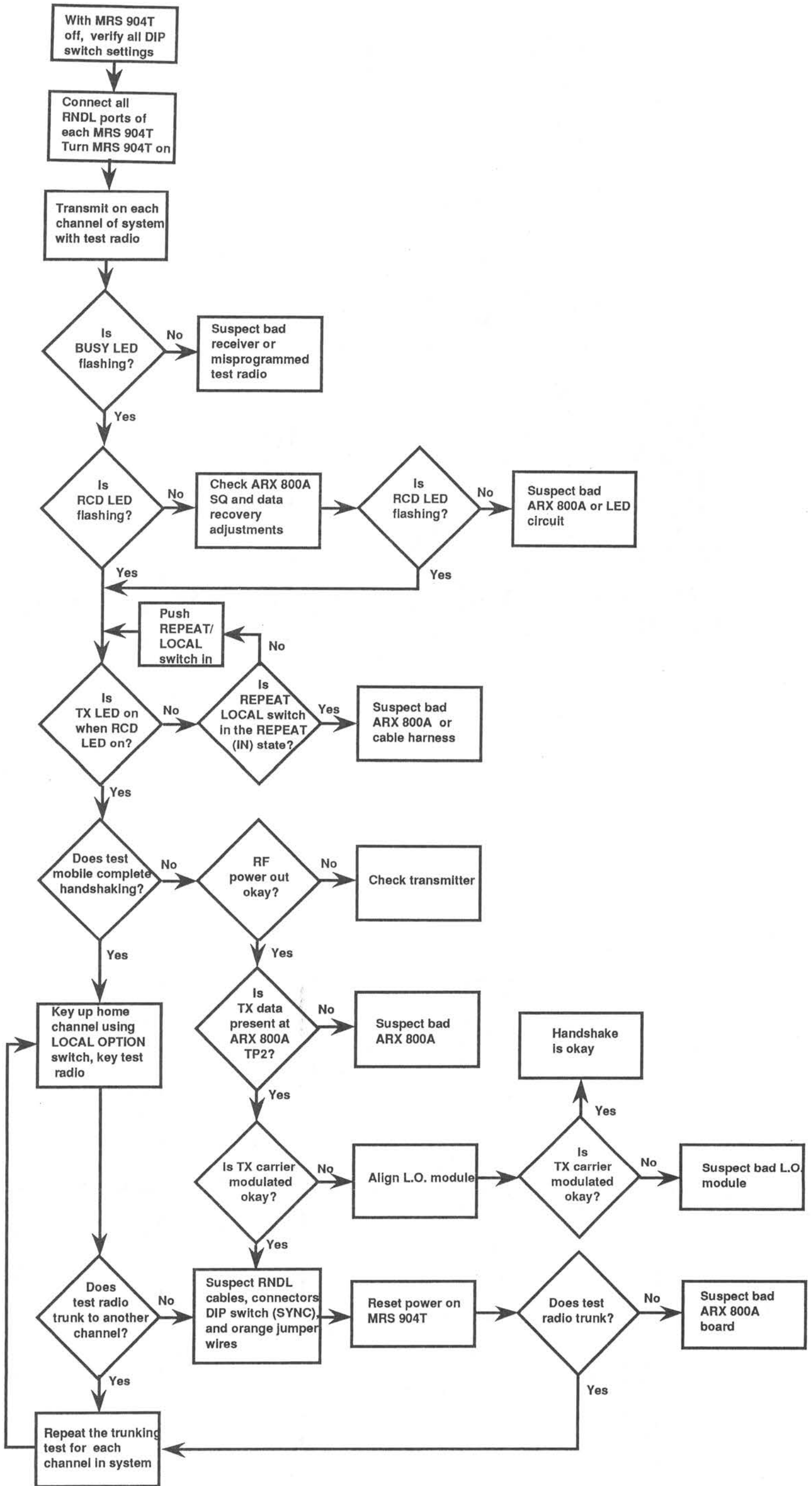

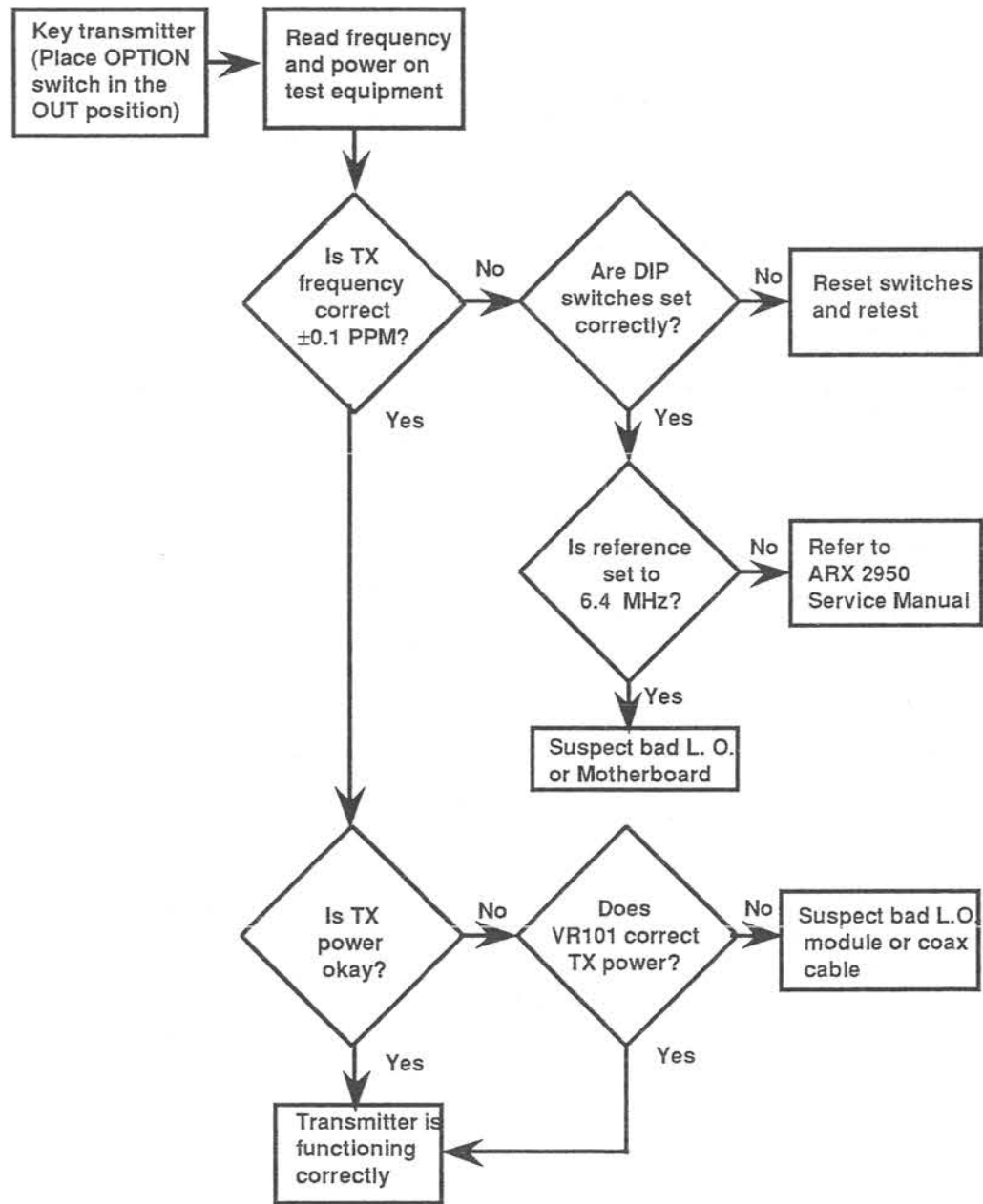

MRS 904 TRANSMITTER  
TROUBLESHOOTING  
FLOW CHART

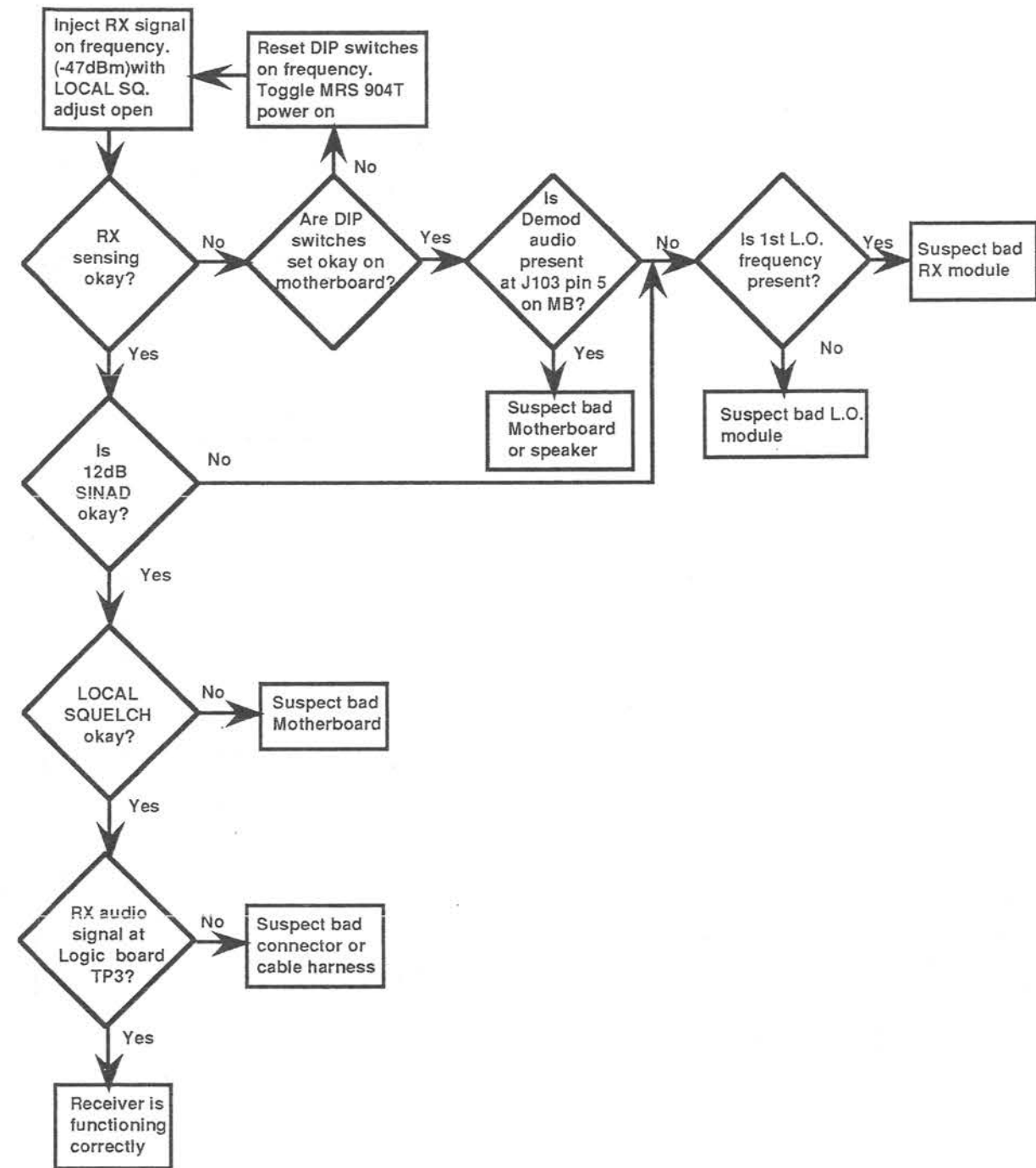

MRS 904 RECEIVER  
TROUBLESHOOTING FLOWCHART

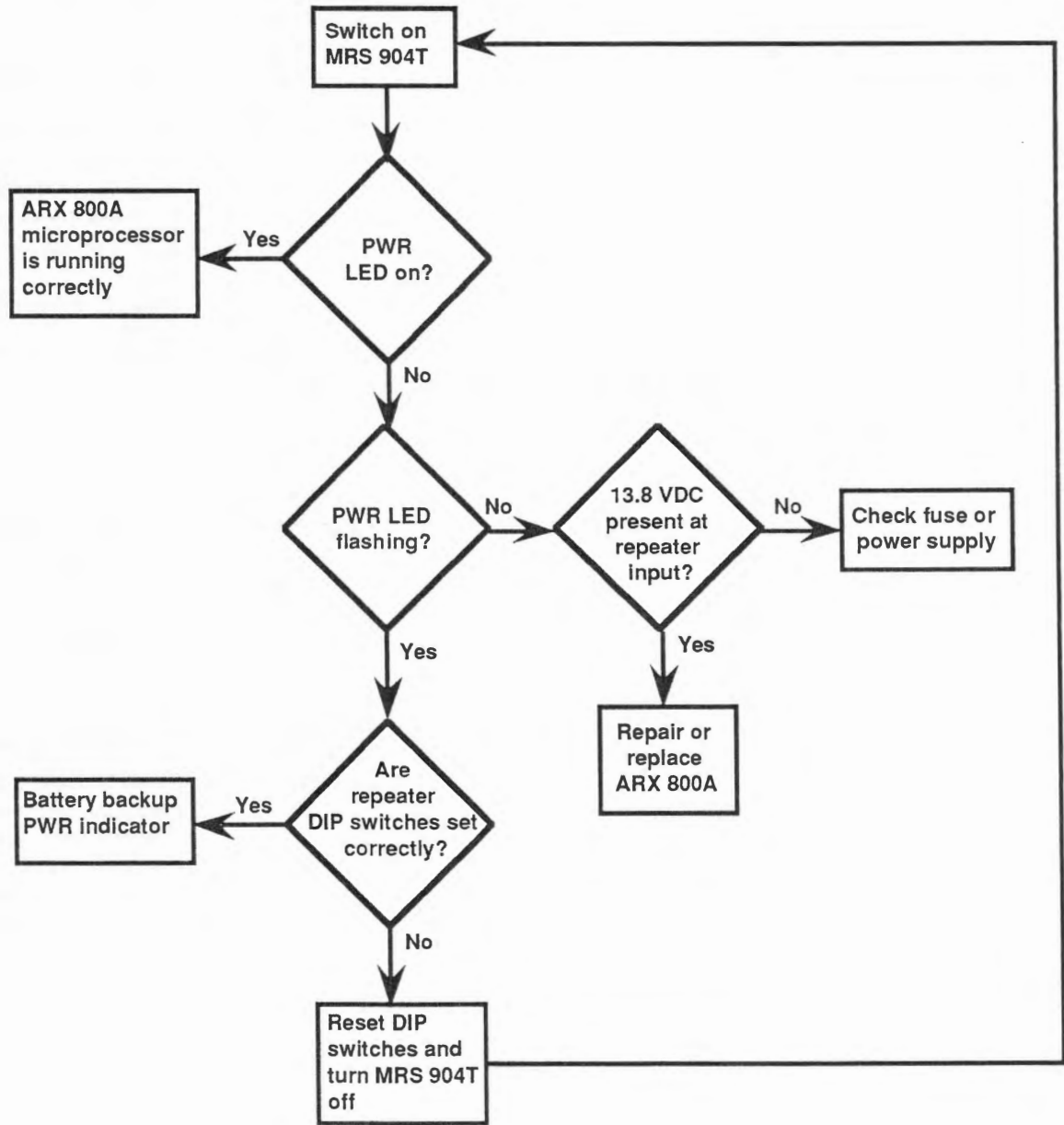

**MRS 904T LOGIC  
TROUBLESHOOTING FLOWCHART**

# MECHANICAL PARTS LIST

## MRS 904T TRUNKING DESK TOP VERSION

Ref.No.	Part Number	Description
1	GCMF180751A	Front Panel
2	GCMZ414434Z	Plastic Slide Piece
3	GNBP480760Z	ARU251 Push Knob
4	GNBY408150Z	ARU 251 Knob
5	HCHF254024Z	Desk Top Bezel
6	HCMT204085Z	Top Cover
7	TSTD0010004	Rubber Foot ABS
8	11000717	#4-40 Hex Nut
9	17000838	Front Insert Clamp Bracket
10	17000533	Repeater Function Label
11	TSTD0191100	4.25" Pre-cut Nylon Edging
12	ECMB154033Z	Base Plate
13	SSCW310406B	#4-40X3/8 Pan Head Phillips Screw
14	SSCW530035N	D3.5 Split Lock Washer
15	SSCW310406B	#4-40X3/8 Pan Head Phillips Screw
16	SSCW311008B	#10-24x1/2" Pan Head Phillips Screw
17	SSCW320404Z	#4-40X1/4 Flat Head Screw
18	SSCW530035N	D3.5 Split Lock Washer
19	11000779	#6 Split Lock Washer Zinc
20	11000704	#6-32X3/4 Pan Head Screw
21	UL026Z	RX Module
22	UL027Z	Local Module
23	BWZY0758001	X-Connection Cable Assy
24	BWZY0759001	TX Cable Assembly
25	BWZY0760001	RX Cable Assembly
26	BWZY0839001	Ref. Osc. Cable Assembly
27	JDPA450044Z	Serial Number Label
28	HZ033	Main Case Assembly
29	ARX800A	Trunking Logic Board
30	11001052	BNC "T" Connector
31	F015	BNC Data Cable
32	JDPA450117Z	Trunking Repeater Function Label
33	11001734	#4-40X1/4 Pan Head Screw

## MRS904S CONVENTIONAL DESK TOP VERSION

Ref.No.	Part Number	Description
1	GCMF180751A	Front Panel
2	GCMZ414434Z	Plastic Slide Piece
3	GNBP480760Z	ARU251 Push Knob
4	GNBY408150Z	ARU 251 Knob
5	HCHF254024Z	Desk Top Bezel
6	HCMT204085Z	Top Cover
7	TSTD0010004	Rubber Foot ABS
8	11000717	#4-40 Hex Nut
9	17000838	Front Insert Clamp Bracket
10	17000533	Repeater Function Label
11	TSTD0191100	4.25" Pre-cut Nylon Edging
12	ECMB154033Z	Base Plate
13	SSCW310406B	#4-40X3/8 Pan Head Phillips Screw
14	SSCW530035N	D3.5 Split Lock Washer
15	SSCW310406B	#4-40X3/8 Pan Head Phillips Screw
16	SSCW311008B	#10-24x1/2" Pan Head Phillips Screw
17	SSCW320404Z	#4-40X1/4 Flat Head Screw
18	SSCW530035N	D3.5 Split Lock Washer
19	11000779	#6 Split Lock Washer Zinc
20	11000704	#6-32X3/4 Pan Head Screw
21	UL026Z	RX Module
22	UL027Z	Local Module
23	BWZY0758001	X-Connection Cable Assy
24	BWZY0759001	TX Cable Assembly
25	BWZY0760001	RX Cable Assembly
26	BWZY0839001	Ref. Osc. Cable Assembly
27	JDPA450044Z	Serial Number Label
28	HZ033	Main Case Assembly
29	ARX720	Conventional Logic Board
30	17000212	Repeater Tone Label
31	11001734	#4-40X1/4 Pan Head Screw

## MRS 904TX TRUNKING RACK MOUNT VERSION

Ref.No.	Part Number	Description
1	ECMF154025Z	Rack Mount Bezel
2	ECMY154026Z	Rack Slide Box
3	GNBP480760Z	ARU 251 Push Knob
4	GNBY408150Z	ARU 251 Knob
5	HCSZ32112Z	Slide Adaptor Plate
6	HCSZ32113Z	Chassis Adaptor Plate
7	HHNS350028Z	Chassis Slide
8	MHNS32111Z	Rack Mount Handle
9	SSCW311106Z	#10-32x3/8" Pan Head Screw
10	SSCW320604B	#6-32x1/4" Flat Head Screw
11	SSCW321008B	#10-24x1/2" Flat Head Screw
12	11000798	#8 External Lock Washer
13	11001709	22 GA Stainless Steel Shim
14	11001778	#8-32x1/4" Pan Head Screw
15	11001779	#12-24x1/2" Pan Head Screw
16	ECMB154033Z	Base Plate
17	SSCW310406B	#4-40x3/8" Pan Head Screw
18	SSCW530035N	D3.5 Split Lock Washer
19	UL026Z	RX Module
20	UL027Z	Local Module
21	BWZY0758001	X-Connection Cable Assy
22	BWZY0759001	TX Cable Assembly
23	BWZY0760001	RX Cable Assembly
24	BWZY0839001	Ref. Osc. Cable Assembly
25	JDPA450044Z	Serial Number Label
26	HZ033	Main Case Assembly
27	ARX800A	Trunking Logic Board
28	11001052	BNC "T" Connector
29	F015	BNC Data Cable
30	JDPA450117Z	Trunking Repeater Function Label
31	11001734	#4-40X1/4 Pan Head Screw

## MRS 904SX CONVENTIONAL RACK MOUNT VERSION

Ref.No.	Part Number	Description
1	ECMF154025Z	Rack Mount Bezel
2	ECMY154026Z	Rack Slide Box
3	GNBP480760Z	ARU 251 Push Knob
4	GNBY408150Z	ARU 251 Knob
5	HCSZ32112Z	Slide Adaptor Plate
6	HCSZ32113Z	Chassis Adaptor Plate
7	HHNS350028Z	Chassis Slide
8	MHNS32111Z	Rack Mount Handle
9	SSCW311106Z	#10-32x3/8" Pan Head Screw
10	SSCW320604B	#6-32x1/4" Flat Head Screw
11	SSCW321008B	#10-24x1/2" Flat Head Screw
12	11000798	#8 External Lock Washer
13	11001709	22 GA Stainless Steel Shim
14	11001778	#8-32x1/4" Pan Head Screw
15	11001779	#12-24x1/2" Pan Head Screw
16	ECMB154033Z	Base Plate
17	SSCW310406B	#4-40x3/8" Pan Head Screw
18	SSCW530035N	D3.5 Split Lock Washer
19	UL026Z	RX Module
20	UL027Z	Local Module
21	BWZY0758001	X-Connection Cable Assly
22	BWZY0759001	TX Cable Assembly
23	BWZY0760001	RX Cable Assembly
24	BWZY0839001	Ref. Osc. Cable Assembly
25	JDPA450044Z	Serial Number Label
26	HZ033	Main Case Assembly
27	ARX720A	Conventional Logic Board
28	17000212	Repeater Tone Label
29	11001734	#4-40X1/4 Pan Head Screw

## INTERNAL PARTS

Ref.No.	Part Number	Description
1	HCMZ154029Z	Chassis
2	HCMF154027Z	Front Panel
3	HCMZ154028Z	Rear Panel
4	ECSV154032Z	Sub-Chassis
5	HCMZ352114Z	Hinge Bracket
6	UL006Z	Receiver Module
7	UL007Z	Local Oscillator Module
8	UL005Z	Motherboard
9		LED PCB Assembly
10		Switch PCB Assembly
11		Relay PCB Assembly
12		Wiring Harness Assembly
13		RX Cable Assembly
14		TX Cable Assembly
15		X-Connection Cable Assly
16	30000082	AC Power Switch XRM-21ON-00
17	BRVY0239001	Volume Control 10KA RV-239
18	BRVY0324001	Squelch Control 10KB RV-324
19	BJKY0207001	Microphone Jack JK-207
20	BSPY0014001	Speaker SP-014
21	11000826	7/16" Hole Plug DP-437
22	(2683DP-750)	3/4" Hole Plug
23	11000825	15/32" Grommet
24	(2073SB-625)	5/8" Grommet
25	GNBP480760Z	Push Button
26	JDPA451174Z	Serial Number Label
27	JDPA454031Z	Rear Escutcheon
28	11001046	Connector Bulkhead
29	BWZY0225001	DC Power Cord WZ-225
30	22000426	Ferrite Bead (ATL1100) PA
31		Coax Cable Retainer
32	34000025	Cable Clamp
33	11000116	Molex Pin
34	11000134	Shield Ground Lug
35	11000784	Locking Terminal Lug
36	(205817-4)	DB15 Standoff Kit
37	(9X15M0506)	M5.8x6 mm Shoulder Screw
38	BRPB616824Z	6.8K 1/6W J Resistor
39	11001734	#4-40X1/4 Pan Head Screw
40	11001750	#4-40x3/8" Pan Head Screw
41	SSCW310406B	#4-40X3/8 Pan Head Phillips Screw
42	11001772	#4-40X1/2 Pan Head Screw
43	11000799	#6-32X1/4 Pan Head Screw
44		#4 Flat Washer
45		#4 Split Lock Washer
46	11000779	#6 Split Lock Washer
47	99160000	16 AWG Black Wire
48	99160002	16 AWG Red Wire
49		Heatsink Compound
50	99240003	24 AWG Black Wire

## RECEIVER MODULE

Ref.No.	Part Number	Description
1	HSDC382918Z	Chassis Assembly
2A	HSDC482976Z	Shield Case SPCD
2B	HSDC482976Z	Shield Case SPCD
3	HSDC482986Z	Shield Case SPCC NI-3
4	HSDP282925Z	Cover (A) SUS 304
5	HSDP282927Z	Cover (B) SUS 304
6	HSDP483276Z	Shield Plate (A) SPTE 0.3T
7	HSDP482979Z	Shield Plate (C) SPTE 0.3T
8	HSDP482980Z	Shield Plate (D) SPTE 0.3T
9	HSDP482981Z	Shield Plate (E) SPTE 0.3T
10	LRNG481895Z	O-Ring NBR D1 8*2.0
11	PLBS415685Z	Serial Number Label
12	PLBZ482572Z	Caution Label
13	RZEB483092Z	Insulation Plate
14	SSCW102606N	M2.6x6 Pan Head Screw
15	SSCW102610N	M2.6x10 Pan Head Screw
16	SSCW103025N	M3x25 Pan Head Screw
17	SSCW430026N	M2.6 Hex Nut
18	SSCW510026N	D2.6 Spring Washer
19	SSCW530026N	D2.6 Lock Washer
20	TSTD0453045	Nylon Rivet
21	HETC483285Z	Toucher (B) SPTE 0.3T
22	HSDP483822Z	Shield Plate (E) SPTE 0.3T

## LOCAL OSCILLATOR MODULE

Ref.No.	Part Number	Description
1	HSDC382919Z	Chassis Assembly
2	HSDC483278Z	Shield Case SPTE 0.3T
3	HSDP282926Z	Cover (D) SUS 304
4	HSDP282967Z	Cover (C) SUS 304
5	LRNG481895Z	O-Ring NBR D1 8*2.0
6	PLBS415685Z	Serial Number Label
7	SSCW102606N	M2.6x6 Pan Head Screw
8	SSCW102610N	M2.6x10 Pan Head Screw
9	<u>SSCW103025N</u>	<u>M3x25 Pan Head Screw</u>
10	HPSP482820Z	Earth Plate C5210, 0.1T, MBNI3
11	SSCW430026N	M2.6 Hex Nut
12	TSTD0453045	Nylon Rivet
13	HSDP482982Z	Shield Plate SPTE 0.3T
14	HHDE482821Z	IC Holder
15	HSDP483812Z	Shield Plate (B) C5210P, 0.3T
16	HSDP483813Z	Shield Plate (C) C5210P, 0.3T
17	SSCW510026N	D2.6 Spring Washer
18	SSCW530026N	D2.6 Lock Washer
19	SSCW192008N	M2x8 Bind Head Screw
20	HETC483285Z	Toucher (B) SPTE 0.3T

# ALIGNMENT PROCEDURES

The MRS 904 alignment procedures require the following test equipment:

- DC Power Supply (13.6V)
- Oscilloscope
- RF Wattmeter
- AF Signal Generator
- RF Dummy Load, 50 Ohms
- RF Signal Generator
- DC Voltmeter
- Deviation Meter
- Distortion Meter
- Frequency Counter

Set up this test equipment as shown in figure 11.

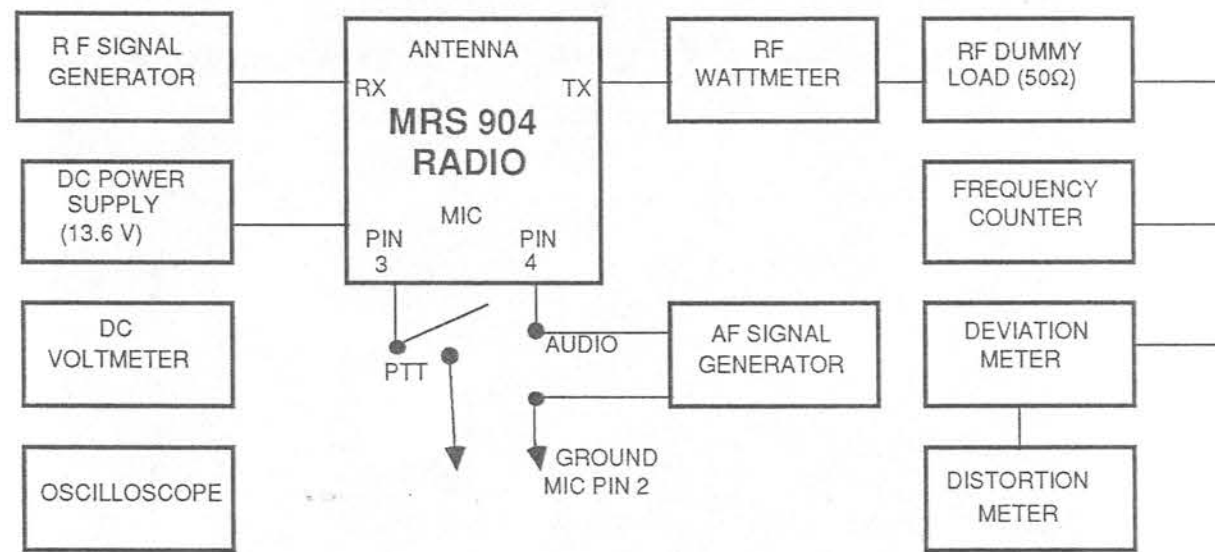

Figure 11. Test Equipment Setup

## NOTES

There are no receiver adjustments/alignments.

1. Before you begin this procedure, make sure that J105 on the Motherboard is in the "900" position.
2. If you are using the Trunking Version (MRS 904T), Make sure that J101 is in the "T" position. If you are using the Conventional Version (MRS 904S), Make sure that J101 is in the "C" position.

## EXTERNAL DC POWER SUPPLY ADJUSTMENT

1. Turn the external power supply on.
2. Connect a DC voltmeter to the output of the external power supply.
3. Adjust the voltage control on the external power supply to an output between 13.6 and 13.8 VDC.

## LOCAL AUDIO AND SQUELCH ADJUSTMENTS

1. Set the VOLUME control to its physical midpoint and rotate the SQUELCH control fully counterclockwise.
2. Input a strong RF signal (-47dBm) into the repeater. Modulate this signal with a 1000 Hz tone at 1.5 kHz deviation.

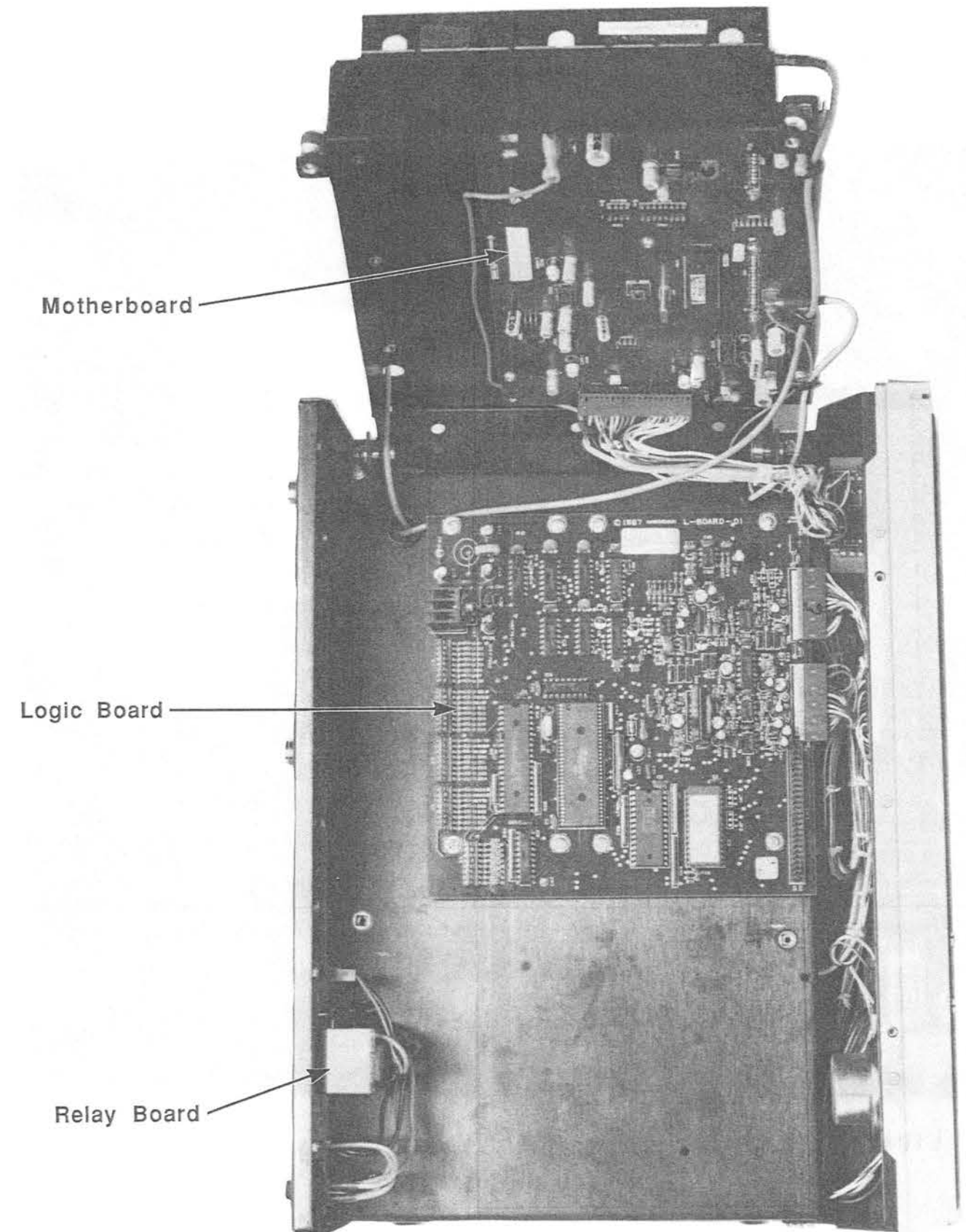

Figure 12. MRS 904 Open View

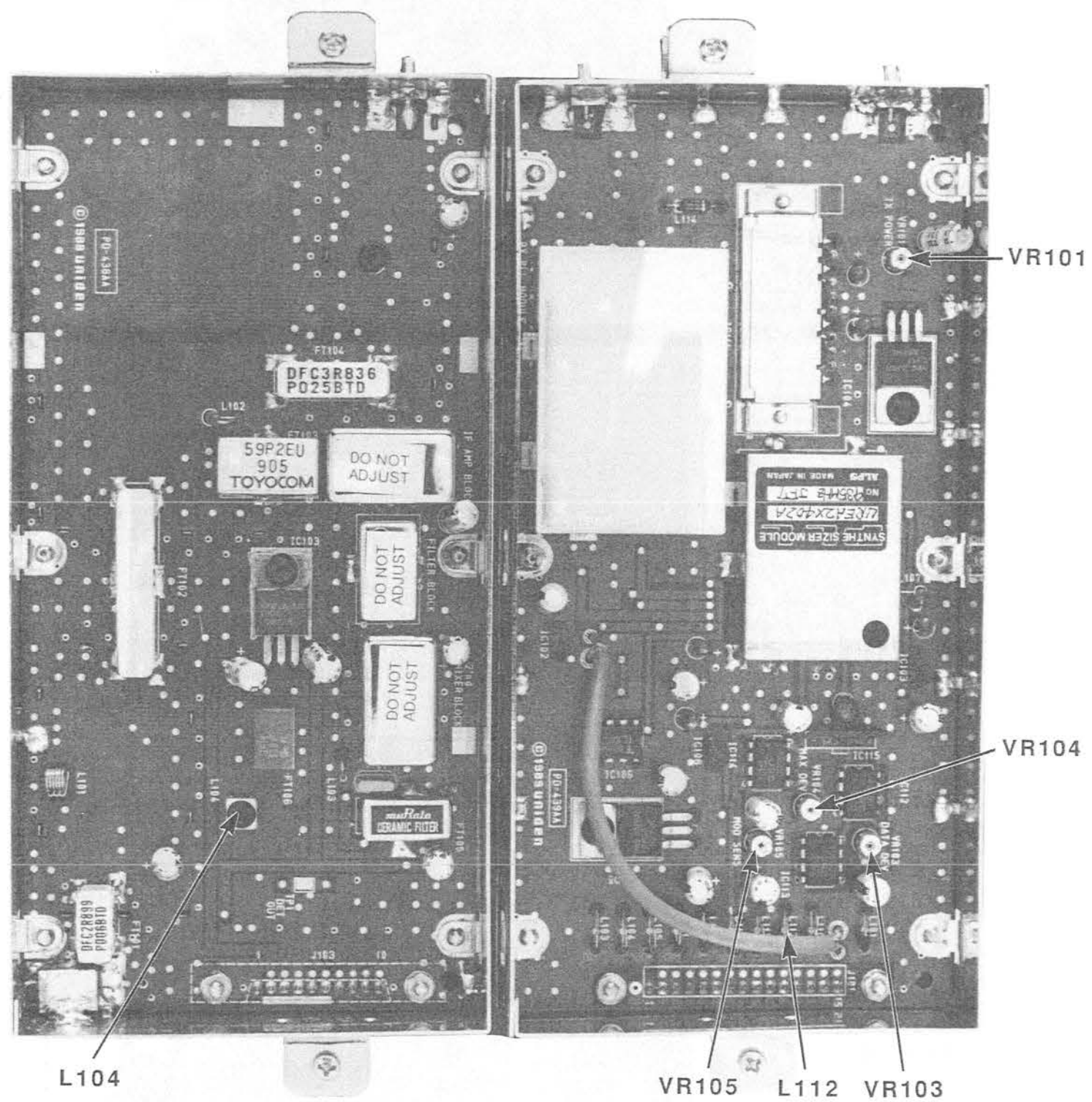

Figure 14. Receiver Module and Local Oscillator Module Alignment Points

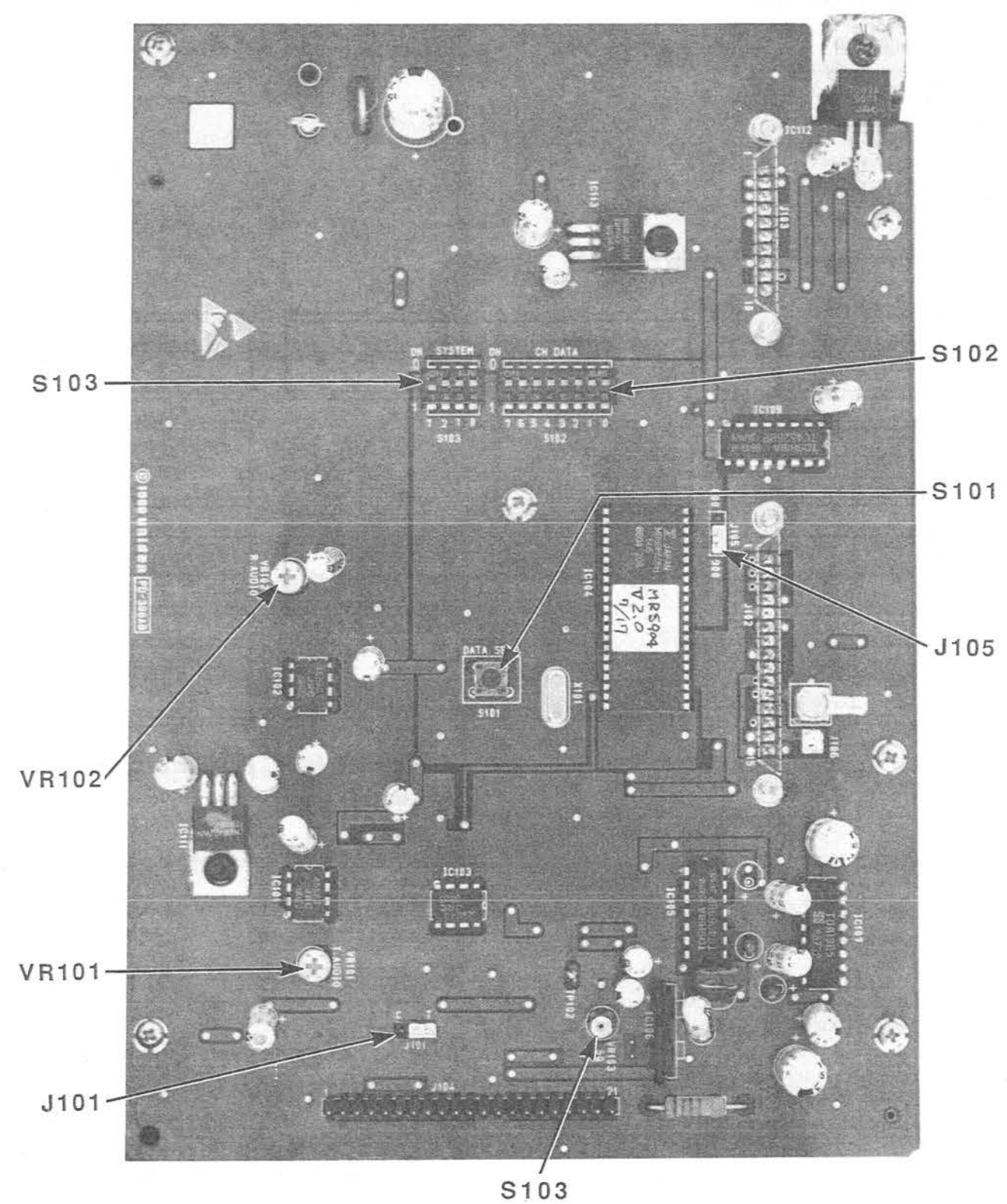

Figure 13. Motherboard Alignment Points



3. Adjust VR102 on the motherboard for the desired local audio level.
4. Rotate the SQUELCH control fully clockwise.
5. Input a 1.0  $\mu$ V RF signal into the repeater.
6. Adjust VR103 on the motherboard until the squelch just opens.

## TRANSMITTER ALIGNMENT PROCEDURE

1. Set DIP switches S102 and S103 on the Motherboard (see figure 13) to the desired frequency using the procedure described in "Frequency Setting".
2. Connect an RF Wattmeter and a 50 Ohm dummy load to the TX antenna jack.
3. Depress the microphone PTT switch and adjust VR101 on the Local Oscillator PCB (see figure 14) for desired power output (between 200 and 400 mW).
4. Rotate VR101 on the Motherboard and VR104 and VR105 on the Local Oscillator PCB fully counter-clockwise.
5. For MRS 904T Trunking Version, depress the microphone PTT switch and adjust VR103 for 900 Hz. Proceed to step 9.
6. For MRS 904S Conventional Version, perform steps 8 through 11 of "Conventional Control Board Alignment Procedure".
7. For MRS 904S Conventional Version, depress the microphone PTT switch and adjust VR103 for 500-700 Hz deviation.
8. Input a 100 mV peak-to-peak (70.7 mV RMS) 1000 Hz tone into the microphone input jack at pin 4.
9. Depress the microphone PTT switch and adjust VR104 on the Local Oscillator PCB for  $\pm 2.4$  kHz total system deviation.

### NOTES

1. Steps 11 through 18 (Repeater Deviation) pertain to MRS 904T Trunking Version only.
2. Before you preset DIP switches S1 and S2 on the Trunking Logic Board(L-BOARD-01), record the original ON/OFF positions 1 thru 8.

10. Set VR4 on the Trunking Logic Board(L-BOARD-01) to its physical midpoint.
11. Set positions 1 through 8 of switch S1 to OFF.
12. Set position 1 of switch S2 to ON and set positions 2 through 8 to OFF.
13. Turn the repeater power switch off, then on.
14. Input a strong (-47 dBm) RF signal into the repeater through the RX jack. Modulate this signal with 1000 Hz at 1.5 kHz deviation.
15. Depress microphone PTT. Adjust VR105 on the Local Oscillator PCB for 2.4 kHz deviation.
16. Return the Trunking Logic Board DIP switches to their original position.
17. Turn the repeater power switch off, then on.

### NOTE

Steps 19 through 23 (Repeater Deviation) pertain to MRS 904S Conventional Version only.

18. Set VR604 on the Conventional Logic PCB (PD-200AB) to its physical midpoint.
19. Set SW600 to CARRIER SQUELCH position and verify that the red LED (D611) is lit.
20. Set the REPEAT/LOCAL switch to REPEAT position.
21. Input a strong (-47 dBm) signal into the repeater using the RX jack. Modulate this signal with 1000 Hz at 1.5 kHz deviation.
22. Depress the microphone PTT switch and adjust VR105 on the Local Oscillator PCB for 1.5 kHz deviation. Set SW600 to the CTCSS position and verify that the red LED (D611) is off.
23. Input a 50 mV peak-to-peak (35.4 mV RMS) 1000 Hz tone into the microphone input jack at pin 4.
24. Depress the microphone PTT switch and adjust VR101 on Motherboard for 2.4 kHz local deviation.

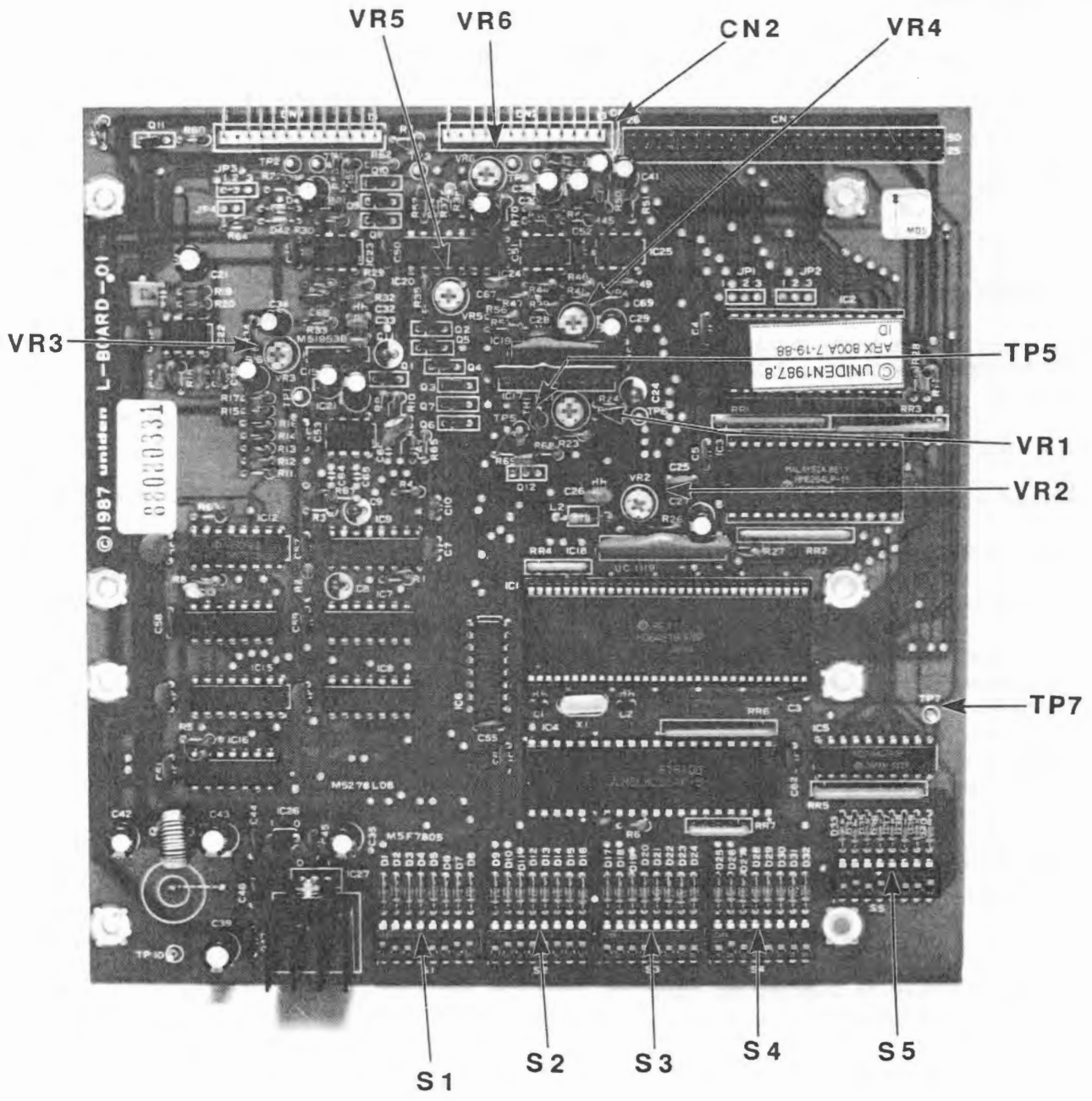

Figure 15. Trunking Logic Board Alignment Points

## TRUNKING LOGIC CONTROLLER (PN ARX 800A) ALIGNMENT PROCEDURE

1. Turn the repeater POWER switch off.
2. Set DIP Switches S1 through S5 (see figure 15) using the procedure described in "Setting the DIP Switches".
3. Turn the repeater POWER switch on.
4. Inject a 1 mV RF signal with a 900 Hz deviation of 100 Hz square wave into the RX jack. Adjust VR1 to obtain a 1.4 V to 2.0V peak-to-peak output at TP5.
5. Adjust VR2 so that the squelch just opens with a 0.15  $\mu$ V input to the RX jack. (TP7 shows 3.6 VDC with the squelch open and  $\pm$ 0.6 VDC with the squelch closed).
6. Turn off the primary power supply and apply backup power (12 VDC) to the repeater using the BATTERY connection.
7. Turn the repeater POWER switch on.
8. Attach the local microphone and depress the PTT switch. Adjust VR3 for  $\pm$ 1.5 kHz peak system deviation.
9. Turn the repeater POWER switch off and disconnect the backup (BATTERY) power supply.
10. Connect the primary power and turn the repeater POWER switch on.
11. Inject a 1 mV RF signal with a  $\pm$ 1.5 kHz deviation of 1000 Hz tone into the RX jack and adjust VR4 for 1.5 kHz total system deviation.
10. Adjust VR5 to its physical midpoint.
11. Adjust VR6 to its physical midpoint.

### NOTE

You must cut the orange jumper from CN 2-1 to CN 2-4 on all repeaters except the first and last repeater in the RNDL chain. If an ARX 850/820 is used in the system, place it at the end of the RNDL bus. Cut the orange jumper between CN2-1 and CN2-4 in the repeater that is adjacent to the ARX 850/820.

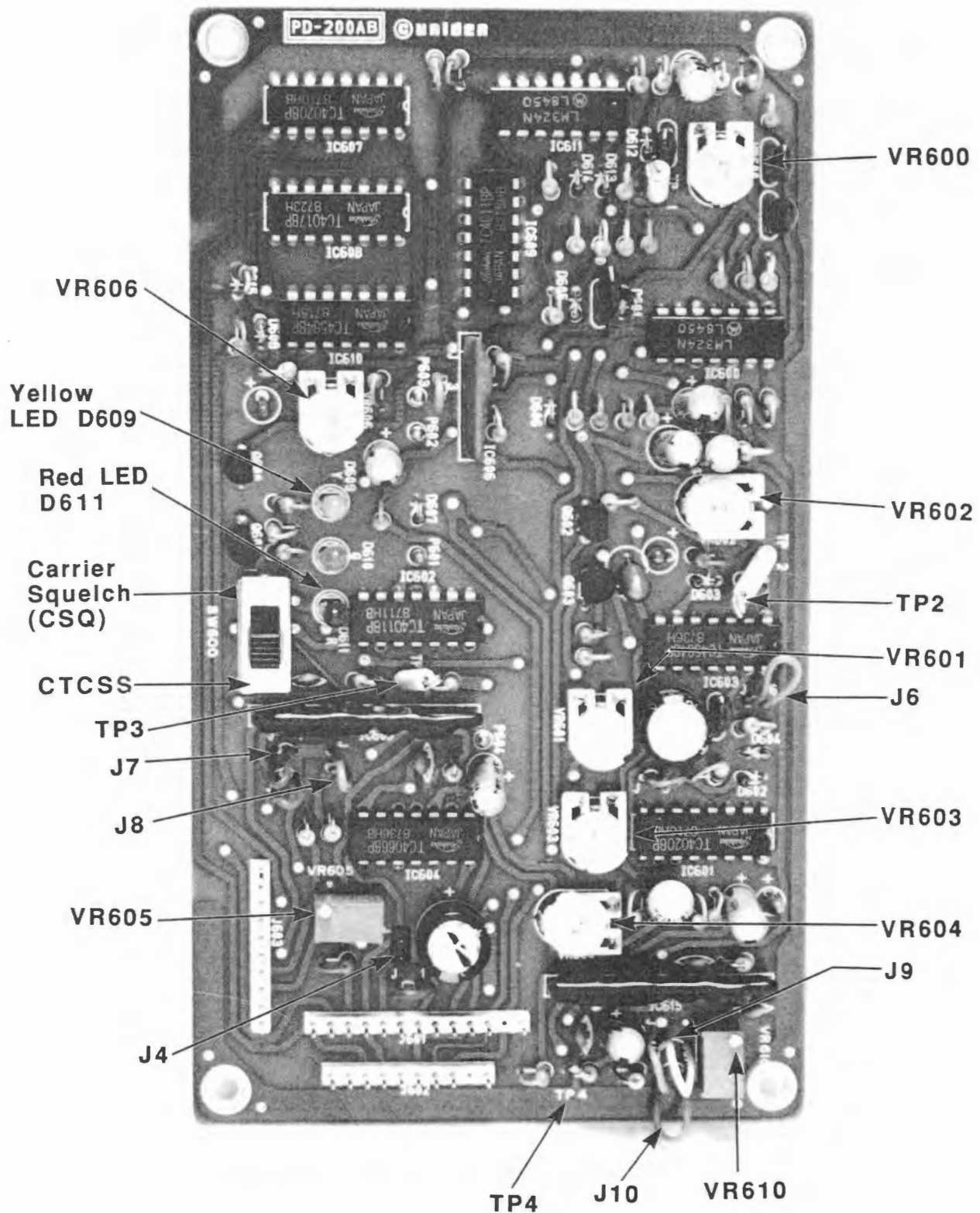

Figure 16. Conventional Control Board Alignment Points

# MRS 904S CONVENTIONAL CONTROL BOARD (PD-200AB) ALIGNMENT PROCEDURE

1. Set the controls on the repeater as follows:
  - a. Set the VOLUME control fully clockwise.
  - b. Set the SQUELCH control fully counterclockwise
  - c. Set the REPEAT/LOCAL switch to LOCAL.
2. Set the controls on the RF signal generator as follows:
  - a. Set the frequency to 1 kHz.
  - b. Set the deviation to 1.5 kHz.
  - c. Set the level to 0.25  $\mu$ V
3. Adjust VR600 (see figure 16) until the yellow LED (D609) just comes on. (Repeater squelch is open).
4. Cut jumpers J9 and J10 for desired decode tone range shown in table 4.

**Table 4. Decoder CTCSS Frequency**

Frequency	J9	J10
160 to 300 Hz	IN	IN
125 to 165 Hz	CUT	IN
60 to 135 Hz	CUT	CUT

5. Connect a frequency counter to TP4 and make sure that jumper J4 is connected.
6. Adjust VR610 to obtain desired decode frequency.
7. Disconnect the frequency counter and cut jumper J4.

### NOTE

When you change the CTCSS Encode Frequency (Steps 8 through 11), you may need to readjust the transmitter data modulation. Refer to the "Transmitter Alignment Procedure", step 8.

8. Cut jumpers J7 and J8 for desired encode tone range:

**Table 5. Encoder CTCSS Frequency**

Frequency	J7	J8
180 to 340 Hz	IN	IN
140 to 190 Hz	CUT	IN
60 to 150 Hz	CUT	CUT

9. Connect a frequency counter to TP3.
10. Adjust VR605 to obtain the desired encode frequency.

11. Disconnect the frequency counter.
12. Set the REPEAT/LOCAL switch on the repeater to REPEAT.
13. Set SW600 to the Carrier Squelch position.
14. Set the level on the RF signal generator to 1.0 mV. The transmitter should key. Verify that the red LED (D611) lights.
15. Adjust VR604 to obtain a 1.5 kHz deviation of the transmitter.
16. Set the REPEAT/LOCAL switch on the repeater to the LOCAL position.
17. Set the level on the RF Signal Generator to 0.25  $\mu$ V.
18. Connect a frequency counter to TP2.
19. Adjust VR602 to obtain the desired time-out time using the formula:
 
$$\text{Frequency} = \frac{8192 \text{ Hz}}{\text{Time in seconds minus 2 seconds}}$$
 For example (2 minute total):
 
$$\text{Frequency} = \frac{8192 \text{ Hz}}{120-2} = 69.42 \text{ Hz}$$
20. Disconnect the frequency counter.
21. Apply a carrier to the receiver. The transmitter should key up.
22. Remove the carrier and adjust VR601 for the desired drop-out delay time.
23. Cut jumper J6, apply a carrier to the receiver, and allow the transmitter to time out.
24. Adjust VR603 for desired deviation of the beep tone (Approximately 1 kHz).
25. Reconnect jumper J6.
26. Set SW600 to the CTCSS position and verify that the red LED (D611) goes off.
27. Disconnect the 13.6 VDC primary power source.
28. Connect the 12.0 VDC backup power source.
29. Depress the local microphone PTT switch and adjust VR606 for the desired warning tone deviation.

# SETTING THE DIP SWITCHES

You must set the Logic PC Board (L-BOARD-01) DIP switches for each repeater in the system. Connect each repeater to the Repeater Network Data Line (RNDL) using the RNDL port on the rear of the repeater. These ports are bi-directional, and a BNC T connector is included with the repeater. This connector allows you to daisy chain the RNDL bus.

## NOTE

The microprocessor in the repeater reads the dip switches only when you turn the repeater's power on. To change the settings, turn off the repeater, make the necessary changes, and then turn on the repeater. The microprocessor reads the new settings when you turn on the repeater.

## SWITCH S1

The following illustration shows the factory set defaults:

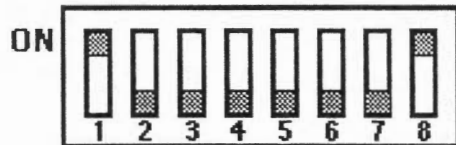

**Position 1-5 = Repeater Number.** The repeater number is a number between 1 and 20 that the repeater uses as an ID when it transmits or receives RNDL data. The repeater also uses the repeater number to identify mobile radios that are homed in on it. The RIC attached to the repeater uses the repeater number to check for data errors and for airtime billing. Table 6 shows the switch settings for repeater numbers 1 through 20. No two repeaters on the RNDL bus should have the same repeater number. You should evenly space the repeater numbers between 1 and 20. For a five channel system use 1,5,9,13, and 17. For a ten channel system use 1,3,5,7,9,11,13,15,17, and 19.

Table 6. Setting the Repeater Number

Rptr #	Position					Rpt r#	Position				
	1	2	3	4	5		1	2	3	4	5
1	1	0	0	0	0	11	1	1	0	1	0
2	0	1	0	0	0	12	0	0	1	1	0
3	1	1	0	0	0	13	1	0	1	1	0
4	0	0	1	0	0	14	0	1	1	1	0
5	1	0	1	0	0	15	1	1	1	1	0
6	0	1	1	0	0	16	0	0	0	0	1
7	1	1	1	0	0	17	1	0	0	0	1
8	0	0	0	1	0	18	0	1	0	0	1
9	1	0	0	1	0	19	1	1	0	0	1
10	0	1	0	1	0	20	0	0	1	0	1

**Position 6-7 = RNDL Mode** - The RNDL mode is set to one of the following values:

- 00 = No sync. This is the mode for all repeaters except the sync repeater.
- 01 = Primary sync. This is usually the highest frequency repeater (lowest number). You should set only one repeater in a system as the sync repeater. Set all other repeaters to 00 (no sync).
- 10 = Secondary sync. A secondary sync repeater backs up the primary sync repeater. If the primary sync repeater stops sending sync, the secondary sync repeater provides sync. If the primary sync repeater stops sending sync for a short period of time, the secondary sync repeater will begin sending sync. When the primary sync repeater begins sending sync again, there will be dual sync until the secondary sync repeater detects both sync pulses and stop sending sync. For this reason it is suggested not to use secondary sync except in critical situations which require a backup for the primary sync repeater.

11 = Sync loss reset. This mode enables a time-out routine which resets the repeater if RNDL sync data is not received within 4.5 seconds. This reset is equivalent to the power up reset to the repeater. This feature is enabled if you set either or both of positions 6 and 7 to ON.

**Position 8 = RIC (Repeater Interconnect)** - Set this position ON to enable the RIC for telephone interconnect. If the RIC classifies an incoming ID code as an interconnect ID code, the repeater allows the interconnect call to progress. If the RIC classifies the Incoming ID code as a dispatch ID code or if the RIC does not classify the ID code (the RIC is disconnected or not turned on), the repeater treats the call as a dispatch call.

## SWITCH S2

The following illustration shows the factory set defaults:

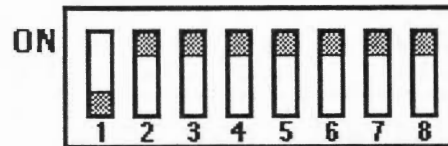

**Position 1-8 = ID Code for Local PTT/Test ID** - This is the repeater ID code and you can set it to a value between 1 and 255 in binary. It is set to a default value of 254 in the factory. If this ID is set to equal a mobile/portable ID, the FCC ID is transmitted upon mobile

dekey. Always set this switch to 254 for normal operation.

### NOTES

1. No mobile in the system should have the same ID code as the local PTT and test message ID code in normal repeat operation.
2. The idle message ID code is 255.

### SWITCH S3

The following illustration shows the factory set defaults:

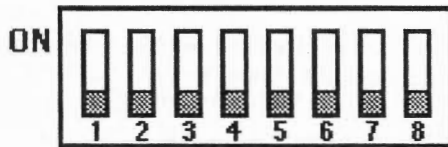

**Position 1-5 = Priority Free Repeater Number.** If a call comes in for the repeater and the repeater is busy, the call is normally trunked to the first available repeater on the RNDL bus. If you set these positions to a valid repeater number, the call is trunked to this repeater number, if it is available. Use the procedure for setting positions 1 through 5 of switch S1 to set these positions. If you set all of these positions OFF, the call is trunked to the first available repeater.

**Position 6 = Reserved.**

**Position 7 = Transmit Data Invert.** This position is usually set OFF to allow for normal subaudible transmit data. This position is set ON to allow for inverted subaudible transmit data. This position is provided to allow you to interface the ARX-800 with non-Uniden equipment.

**Position 8 = Receive Data Invert.** This position is usually set OFF to allow for normal subaudible receive data. This position is set ON to allow for inverted subaudible receive data. This position is provided to allow you to interface the ARX-800 with non-Uniden equipment.

### SWITCH S4

The following illustration shows the factory set defaults:

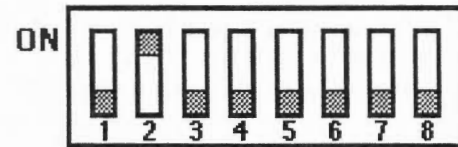

**Position 1-6 = Data Lost Hang Time.** These switches control the amount of time the repeater hangs, or continues to transmit after it loses data decode. This is necessary to keep communications from chattering or dropping out due to fading and weak signal conditions. The factory default is 2 seconds.

**Position 7 = Area.** The Area switch is normally set to OFF. Use this switch when two systems operate on the same frequencies and due to geographic location they interfere with one another. If one system is set to Area 1 (Area switch is ON) then mobile/portable radios with Area programmed to 0 are not allowed to access the system. Likewise, you need to program Area = 1 for all mobile/portable radios on the system with the Area set ON.

**Position 8 = Alert Tone for Loss of Data.** The repeater sends a tone to alert the user that data is no longer being decoded. If the hang time is set long enough, a user may be able to relocate to a position and re-establish proper data decoding before communications cease.

### SWITCH S5

The following illustration shows the factory set defaults:

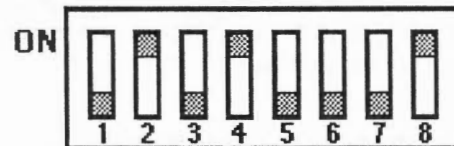

**Position 1-6 = Idle Message Cycle Time.** This time is factory set to 10 seconds. It is programmable in one second intervals between 1 and 64 seconds. The idle message lets mobile/portable units know that the home channel is free and within range.

**Position 7 = Continuous IDLE Message Enabled.** Factory set is OFF.

**Position 8 = FCC Station ID Enable.** Should be set ON, on the lowest frequency repeater only (highest number repeater). Will transmit FCC ID every 30 minutes.

### NOTE

FCC Station ID should be enabled in lowest frequency repeater only.

# MRS 904T REPEATER TEST MODE

If you turn the power to the repeater on with all positions on DIP switch S1 set to OFF (S1-1 thru S1-8), the repeater goes into an audio path test mode. The setting of DIP switch S2 controls the audio path that is active. Each switch position 1 through 4 of switch S2 controls an audio path as follows:

- Position 1 set ON tests the repeater audio path (IC20 pins 10 and 11)
- Position 2 set ON tests the RIC to repeater audio path (IC20 pins 3 and 4)
- Position 3 set ON tests the repeater to RIC audio path (IC20 pins 8 and 9)
- Position 4 set ON tests the beep tone (IC20 pins 1 and 2)

### NOTE

You can set DIP switches S2-1 through S2-4 to ON and OFF without turning the power to the repeater off.

When you press the LOCAL PTT in the test mode, the repeater keys up the transmitter without data for any audio path controlled by S2.

### NOTE

SQ (TP7) must be HIGH to repeat the received audio when S2-1 is in the ON position and the LOCAL PTT is pressed.

## FREQUENCY SETTING

1. Use DIP switches S102 and S103 on the Motherboard to set the frequency. These Switches are labeled SYSTEM and CH DATA on the Motherboard as shown in the following figure.

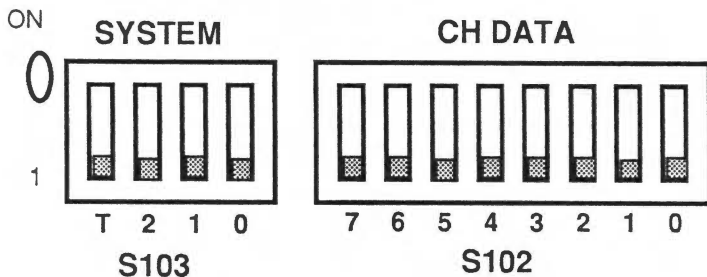

2. There are 400 channels that you can program in the 900 MHz band.
3. To place the repeater in a TEST MODE set position T of switch S103 on 0. In TEST MODE, the repeater operates on the frequencies shown in table 7.

Table 7. Test Mode Frequencies

Mode	RX (MHz)	TX (MHz)	Local (MHz)
1	896.1125	935.1125	836.1750
2	898.5125	937.5125	838.5750
3	900.7875	939.7875	840.8500

The TEST MODE frequencies change each time you press S101 on the Motherboard.

4. To return the repeater to normal operating mode set position T of switch S103 on 1.
5. Select the desired channel frequency from the frequencies listed in Table 8. Set the SYSTEM (S102) and CH DATA (S103) DIP switches according to the table. For example, if you want to set the repeater to channel 384, look for this channel in the table. The receive frequency for channel 384 is 900.8000 MHz, the transmit frequency is 939.8000 MHz and the local frequency is 840.8625 MHz. Table 8 shows the following settings for the SYSTEM and CH DATA switches:

- SYSTEM Switch = 1001
- CH DATA Switch = 0111 1111

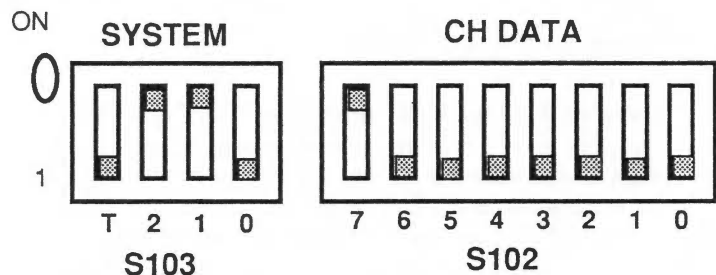

(Note: "T" is in position 1 for normal mode.)



000000 -  
896

Table 8. DIP Switch Settings

FCC Channel Number	System Switch T210	Data Switch		Transmitter Frequency	Receiver Frequency	Local Frequency
		7654	3210			
001	1000	0000	0000	935.0125	896.0125	836.0750
002	1000	0000	0001	935.0250	896.0250	836.0875
003	1000	0000	0010	935.0375	896.0375	836.1000
004	1000	0000	0011	935.0500	896.0500	836.1125
005	1000	0000	0100	935.0625	896.0625	836.1250
006	1000	0000	0101	935.0750	896.0750	836.1375
007	1000	0000	0110	935.0875	896.0875	836.1500
008	1000	0000	0111	935.1000	896.1000	836.1625
009	1000	0000	1000	935.1125	896.1125	836.1750
010	1000	0000	1001	935.1250	896.1250	836.1875
011	1000	0000	1010	935.1375	896.1375	836.2000
012	1000	0000	1011	935.1500	896.1500	836.2125
013	1000	0000	1100	935.1625	896.1625	836.2250
014	1000	0000	1101	935.1750	896.1750	836.2375
015	1000	0000	1110	935.1875	896.1875	836.2500
016	1000	0000	1111	935.2000	896.2000	836.2625
017	1000	0001	0000	935.2125	896.2125	836.2750
018	1000	0001	0001	935.2250	896.2250	836.2875
019	1000	0001	0010	935.2375	896.2375	836.3000
020	1000	0001	0011	935.2500	896.2500	836.3125
021	1000	0001	0100	935.2625	896.2625	836.3250
022	1000	0001	0101	935.2750	896.2750	836.3375
023	1000	0001	0110	935.2875	896.2875	836.3500
024	1000	0001	0111	935.3000	896.3000	836.3625
025	1000	0001	1000	935.3125	896.3125	836.3750
026	1000	0001	1001	935.3250	896.3250	836.3875
027	1000	0001	1010	935.3375	896.3375	836.4000
028	1000	0001	1011	935.3500	896.3500	836.4125
029	1000	0001	1100	935.3625	896.3625	836.4250
030	1000	0001	1101	935.3750	896.3750	836.4375
031	1000	0001	1110	935.3875	896.3875	836.4500
032	1000	0001	1111	935.4000	896.4000	836.4625
033	1000	0010	0000	935.4125	896.4125	836.4750
034	1000	0010	0001	935.4250	896.4250	836.4875
035	1000	0010	0010	935.4375	896.4375	836.5000
036	1000	0010	0011	935.4500	896.4500	836.5125
037	1000	0010	0100	935.4625	896.4625	836.5250
038	1000	0010	0101	935.4750	896.4750	836.5375
039	1000	0010	0110	935.4875	896.4875	836.5500
040	1000	0010	0111	935.5000	896.5000	836.5625
041	1000	0010	1000	935.5125	896.5125	836.5750
042	1000	0010	1001	935.5250	896.5250	836.5875
043	1000	0010	1010	935.5375	896.5375	836.6000
044	1000	0010	1011	935.5500	896.5500	836.6125
045	1000	0010	1100	935.5625	896.5625	836.6250

Table 8. DIP Switch Settings

FCC Channel Number	System Switch T210	Data Switch		Transmitter Frequency	Receiver Frequency	Local Frequency
		7654	3210			
046	1000	0010	1101	935.5750	896.5750	836.6375
047	1000	0010	1110	935.5875	896.5875	836.6500
048	1000	0010	1111	935.6000	896.6000	836.6625
049	1000	0011	0000	935.6125	896.6125	836.6750
050	1000	0011	0001	935.6250	896.6250	836.6875
051	1000	0011	0010	935.6375	896.6375	836.7000
052	1000	0011	0011	935.6500	896.6500	836.7125
053	1000	0011	0100	935.6625	896.6625	836.7250
054	1000	0011	0101	935.6750	896.6750	836.7375
055	1000	0011	0110	935.6875	896.6875	836.7500
056	1000	0011	0111	935.7000	896.7000	836.7625
057	1000	0011	1000	935.7125	896.7125	836.7750
058	1000	0011	1001	935.7250	896.7250	836.7875
059	1000	0011	1010	935.7375	896.7375	836.8000
060	1000	0011	1011	935.7500	896.7500	836.8125
061	1000	0011	1100	935.7625	896.7625	836.8250
062	1000	0011	1101	935.7750	896.7750	836.8375
063	1000	0011	1110	935.7875	896.7875	836.8500
064	1000	0011	1111	935.8000	896.8000	836.8625
065	1000	0100	0000	935.8125	896.8125	836.8750
066	1000	0100	0001	935.8250	896.8250	836.8875
067	1000	0100	0010	935.8375	896.8375	836.9000
068	1000	0100	0011	935.8500	896.8500	836.9125
069	1000	0100	0100	935.8625	896.8625	836.9250
070	1000	0100	0101	935.8750	896.8750	836.9375
071	1000	0100	0110	935.8875	896.8875	836.9500
072	1000	0100	0111	935.9000	896.9000	836.9625
073	1000	0100	1000	935.9125	896.9125	836.9750
074	1000	0100	1001	935.9250	896.9250	836.9875
075	1000	0100	1010	935.9375	896.9375	837.0000
076	1000	0100	1011	935.9500	896.9500	837.0125
077	1000	0100	1100	935.9625	896.9625	837.0250
078	1000	0100	1101	935.9750	896.9750	837.0375
079	1000	0100	1110	935.9875	896.9875	837.0500
080	1000	0100	1111	936.0000	897.0000	837.0625
081	1000	0101	0000	936.0125	897.0125	837.0750
082	1000	0101	0001	936.0250	897.0250	837.0875
083	1000	0101	0010	936.0375	897.0375	837.1000
084	1000	0101	0011	936.0500	897.0500	837.1125
085	1000	0101	0100	936.0625	897.0625	837.1250
086	1000	0101	0101	936.0750	897.0750	837.1375
087	1000	0101	0110	936.0875	897.0875	837.1500
088	1000	0101	0111	936.1000	897.1000	837.1625
089	1000	0101	1000	936.1125	897.1125	837.1750
090	1000	0101	1001	936.1250	897.1250	837.1875

Table 8. DIP Switch Settings

FCC Channel Number	System Switch T210	Data Switch		Transmitter Frequency	Receiver Frequency	Local Frequency
		7654	3210			
091	1000	0101	1010	936.1375	897.1375	837.2000
092	1000	0101	1011	936.1500	897.1500	837.2125
093	1000	0101	1100	936.1625	897.1625	837.2250
094	1000	0101	1101	936.1750	897.1750	837.2375
095	1000	0101	1110	936.1875	897.1875	837.2500
096	1000	0101	1111	936.2000	897.2000	837.2625
097	1000	0110	0000	936.2125	897.2125	837.2750
098	1000	0110	0001	936.2250	897.2250	837.2875
099	1000	0110	0010	936.2375	897.2375	837.3000
100	1000	0110	0011	936.2500	897.2500	837.3125
101	1000	0110	0100	936.2625	897.2625	837.3250
102	1000	0110	0101	936.2750	897.2750	837.3375
103	1000	0110	0110	936.2875	897.2875	837.3500
104	1000	0110	0111	936.3000	897.3000	837.3625
105	1000	0110	1000	936.3125	897.3125	837.3750
106	1000	0110	1001	936.3250	897.3250	837.3875
107	1000	0110	1010	936.3375	897.3375	837.4000
108	1000	0110	1011	936.3500	897.3500	837.4125
109	1000	0110	1100	936.3625	897.3625	837.4250
110	1000	0110	1101	936.3750	897.3750	837.4375
111	1000	0110	1110	936.3875	897.3875	837.4500
112	1000	0110	1111	936.4000	897.4000	837.4625
113	1000	0111	0000	936.4125	897.4125	837.4750
114	1000	0111	0001	936.4250	897.4250	837.4875
115	1000	0111	0010	936.4375	897.4375	837.5000
116	1000	0111	0011	936.4500	897.4500	837.5125
117	1000	0111	0100	936.4625	897.4625	837.5250
118	1000	0111	0101	936.4750	897.4750	837.5375
119	1000	0111	0110	936.4875	897.4875	837.5500
120	1000	0111	0111	936.5000	897.5000	837.5625
121	1000	0111	1000	936.5125	897.5125	837.5750
122	1000	0111	1001	936.5250	897.5250	837.5875
123	1000	0111	1010	936.5375	897.5375	837.6000
124	1000	0111	1011	936.5500	897.5500	837.6125
125	1000	0111	1100	936.5625	897.5625	837.6250
126	1000	0111	1101	936.5750	897.5750	837.6375
127	1000	0111	1110	936.5875	897.5875	837.6500
128	1000	0111	1111	936.6000	897.6000	837.6625
129	1000	1000	0000	936.6125	897.6125	837.6750
130	1000	1000	0001	936.6250	897.6250	837.6875
131	1000	1000	0010	936.6375	897.6375	837.7000
132	1000	1000	0011	936.6500	897.6500	837.7125
133	1000	1000	0100	936.6625	897.6625	837.7250
134	1000	1000	0101	936.6750	897.6750	837.7375
135	1000	1000	0110	936.6875	897.6875	837.7500

Table 8. DIP Switch Settings

FCC Channel Number	System Switch T210	Data Switch		Transmitter Frequency	Receiver Frequency	Local Frequency
		7654	3210			
136	1000	1000	0111	936.7000	897.7000	837.7625
137	1000	1000	1000	936.7125	897.7125	837.7750
138	1000	1000	1001	936.7250	897.7250	837.7875
139	1000	1000	1010	936.7375	897.7375	837.8000
140	1000	1000	1011	936.7500	897.7500	837.8125
141	1000	1000	1100	936.7625	897.7625	837.8250
142	1000	1000	1101	936.7750	897.7750	837.8375
143	1000	1000	1110	936.7875	897.7875	837.8500
144	1000	1000	1111	936.8000	897.8000	837.8625
145	1000	1001	0000	936.8125	897.8125	837.8750
146	1000	1001	0001	936.8250	897.8250	837.8875
147	1000	1001	0010	936.8375	897.8375	837.9000
148	1000	1001	0011	936.8500	897.8500	837.9125
149	1000	1001	0100	936.8625	897.8625	837.9250
150	1000	1001	0101	936.8750	897.8750	837.9375
151	1000	1001	0110	936.8875	897.8875	837.9500
152	1000	1001	0111	936.9000	897.9000	837.9625
153	1000	1001	1000	936.9125	897.9125	837.9750
154	1000	1001	1001	936.9250	897.9250	837.9875
155	1000	1001	1010	936.9375	897.9375	838.0000
156	1000	1001	1011	936.9500	897.9500	838.0125
157	1000	1001	1100	936.9625	897.9625	838.0250
158	1000	1001	1101	936.9750	897.9750	838.0375
159	1000	1001	1110	936.9875	897.9875	838.0500
160	1000	1001	1111	937.0000	898.0000	838.0625
161	1000	1010	0000	937.0125	898.0125	838.0750
162	1000	1010	0001	937.0250	898.0250	838.0875
163	1000	1010	0010	937.0375	898.0375	838.1000
164	1000	1010	0011	937.0500	898.0500	838.1125
165	1000	1010	0100	937.0625	898.0625	838.1250
166	1000	1010	0101	937.0750	898.0750	838.1375
167	1000	1010	0110	937.0875	898.0875	838.1500
168	1000	1010	0111	937.1000	898.1000	838.1625
169	1000	1010	1000	937.1125	898.1125	838.1750
170	1000	1010	1001	937.1250	898.1250	838.1875
171	1000	1010	1010	937.1375	898.1375	838.2000
172	1000	1010	1011	937.1500	898.1500	838.2125
173	1000	1010	1100	937.1625	898.1625	838.2250
174	1000	1010	1101	937.1750	898.1750	838.2375
175	1000	1010	1110	937.1875	898.1875	838.2500
176	1000	1010	1111	937.2000	898.2000	838.2625
177	1000	1011	0000	937.2125	898.2125	838.2750
178	1000	1011	0001	937.2250	898.2250	838.2875
179	1000	1011	0010	937.2375	898.2375	838.3000
180	1000	1011	0011	937.2500	898.2500	838.3125

Table 8. DIP Switch Settings

FCC Channel Number	System Switch T210	Data Switch		Transmitter Frequency	Receiver Frequency	Local Frequency
		7654	3210			
181	1000	1011	0100	937.2625	898.2625	838.3250
182	1000	1011	0101	937.2750	898.2750	838.3375
183	1000	1011	0110	937.2875	898.2875	838.3500
184	1000	1011	0111	937.3000	898.3000	838.3625
185	1000	1011	1000	937.3125	898.3125	838.3750
186	1000	1011	1001	937.3250	898.3250	838.3875
187	1000	1011	1010	937.3375	898.3375	838.4000
188	1000	1011	1011	937.3500	898.3500	838.4125
189	1000	1011	1100	937.3625	898.3625	838.4250
190	1000	1011	1101	937.3750	898.3750	838.4375
191	1000	1011	1110	937.3875	898.3875	838.4500
192	1000	1011	1111	937.4000	898.4000	838.4625
193	1000	1100	0000	937.4125	898.4125	838.4750
194	1000	1100	0001	937.4250	898.4250	838.4875
195	1000	1100	0010	937.4375	898.4375	838.5000
196	1000	1100	0011	937.4500	898.4500	838.5125
197	1000	1100	0100	937.4625	898.4625	838.5250
198	1000	1100	0101	937.4750	898.4750	838.5375
199	1000	1100	0110	937.4875	898.4875	838.5500
200	1000	1100	0111	937.5000	898.5000	838.5625
201	1000	1100	1000	937.5125	898.5125	838.5750
202	1000	1100	1001	937.5250	898.5250	838.5875
203	1000	1100	1010	937.5375	898.5375	838.6000
204	1000	1100	1011	937.5500	898.5500	838.6125
205	1000	1100	1100	937.5625	898.5625	838.6250
206	1000	1100	1101	937.5750	898.5750	838.6375
207	1000	1100	1110	937.5875	898.5875	838.6500
208	1000	1100	1111	937.6000	898.6000	838.6625
209	1000	1101	0000	937.6125	898.6125	838.6750
210	1000	1101	0001	937.6250	898.6250	838.6875
211	1000	1101	0010	937.6375	898.6375	838.7000
212	1000	1101	0011	937.6500	898.6500	838.7125
213	1000	1101	0100	937.6625	898.6625	838.7250
214	1000	1101	0101	937.6750	898.6750	838.7375
215	1000	1101	0110	937.6875	898.6875	838.7500
216	1000	1101	0111	937.7000	898.7000	838.7625
217	1000	1101	1000	937.7125	898.7125	838.7750
218	1000	1101	1001	937.7250	898.7250	838.7875
219	1000	1101	1010	937.7375	898.7375	838.8000
220	1000	1101	1011	937.7500	898.7500	838.8125
221	1000	1101	1100	937.7625	898.7625	838.8250
222	1000	1101	1101	937.7750	898.7750	838.8375
223	1000	1101	1110	937.7875	898.7875	838.8500
224	1000	1101	1111	937.8000	898.8000	838.8625
225	1000	1110	0000	937.8125	898.8125	838.8750

Table 8. DIP Switch Settings

FCC Channel Number	System Switch T210	Data Switch		Transmitter Frequency	Receiver Frequency	Local Frequency
		7654	3210			
226	1000	1110	0001	937.8250	898.8250	838.8875
227	1000	1110	0010	937.8375	898.8375	838.9000
228	1000	1110	0011	937.8500	898.8500	838.9125
229	1000	1110	0100	937.8625	898.8625	838.9250
230	1000	1110	0101	937.8750	898.8750	838.9375
231	1000	1110	0110	937.8875	898.8875	838.9500
232	1000	1110	0111	937.9000	898.9000	838.9625
233	1000	1110	1000	937.9125	898.9125	838.9750
234	1000	1110	1001	937.9250	898.9250	838.9875
235	1000	1110	1010	937.9375	898.9375	839.0000
236	1000	1110	1011	937.9500	898.9500	839.0125
237	1000	1110	1100	937.9625	898.9625	839.0250
238	1000	1110	1101	937.9750	898.9750	839.0375
239	1000	1110	1110	937.9875	898.9875	839.0500
240	1000	1110	1111	938.0000	899.0000	839.0625
241	1000	1111	0000	938.0125	899.0125	839.0750
242	1000	1111	0001	938.0250	899.0250	839.0875
243	1000	1111	0010	938.0375	899.0375	839.1000
244	1000	1111	0011	938.0500	899.0500	839.1125
245	1000	1111	0100	938.0625	899.0625	839.1250
246	1000	1111	0101	938.0750	899.0750	839.1375
247	1000	1111	0110	938.0875	899.0875	839.1500
248	1000	1111	0111	938.1000	899.1000	839.1625
249	1000	1111	1000	938.1125	899.1125	839.1750
250	1000	1111	1001	938.1250	899.1250	839.1875
251	1000	1111	1010	938.1375	899.1375	839.2000
252	1000	1111	1011	938.1500	899.1500	839.2125
253	1000	1111	1100	938.1625	899.1625	839.2250
254	1000	1111	1101	938.1750	899.1750	839.2375
255	1000	1111	1110	938.1875	899.1875	839.2500
256	1000	1111	1111	938.2000	899.2000	839.2625
257	1001	0000	0000	938.2125	899.2125	839.2750
258	1001	0000	0001	938.2250	899.2250	839.2875
259	1001	0000	0010	938.2375	899.2375	839.3000
260	1001	0000	0011	938.2500	899.2500	839.3125
261	1001	0000	0100	938.2625	899.2625	839.3250
262	1001	0000	0101	938.2750	899.2750	839.3375
263	1001	0000	0110	938.2875	899.2875	839.3500
264	1001	0000	0111	938.3000	899.3000	839.3625
265	1001	0000	1000	938.3125	899.3125	839.3750
266	1001	0000	1001	938.3250	899.3250	839.3875
267	1001	0000	1010	938.3375	899.3375	839.4000
268	1001	0000	1011	938.3500	899.3500	839.4125
269	1001	0000	1100	938.3625	899.3625	839.4250
270	1001	0000	1101	938.3750	899.3750	839.4375

Table 8. DIP Switch Settings

FCC Channel Number	System Switch T210	Data Switch		Transmitter Frequency	Receiver Frequency	Local Frequency
		7654	3210			
271	1001	0000	1110	938.3875	899.3875	839.4500
272	1001	0000	1111	938.4000	899.4000	839.4625
273	1001	0001	0000	938.4125	899.4125	839.4750
274	1001	0001	0001	938.4250	899.4250	839.4875
275	1001	0001	0010	938.4375	899.4375	839.5000
276	1001	0001	0011	938.4500	899.4500	839.5125
277	1001	0001	0100	938.4625	899.4625	839.5250
278	1001	0001	0101	938.4750	899.4750	839.5375
279	1001	0001	0110	938.4875	899.4875	839.5500
280	1001	0001	0111	938.5000	899.5000	839.5625
281	1001	0001	1000	938.5125	899.5125	839.5750
282	1001	0001	1001	938.5250	899.5250	839.5875
283	1001	0001	1010	938.5375	899.5375	839.6000
284	1001	0001	1011	938.5500	899.5500	839.6125
285	1001	0001	1100	938.5625	899.5625	839.6250
286	1001	0001	1101	938.5750	899.5750	839.6375
287	1001	0001	1110	938.5875	899.5875	839.6500
288	1001	0001	1111	938.6000	899.6000	839.6625
289	1001	0010	0000	938.6125	899.6125	839.6750
290	1001	0010	0001	938.6250	899.6250	839.6875
291	1001	0010	0010	938.6375	899.6375	839.7000
292	1001	0010	0011	938.6500	899.6500	839.7125
293	1001	0010	0100	938.6625	899.6625	839.7250
294	1001	0010	0101	938.6750	899.6750	839.7375
295	1001	0010	0110	938.6875	899.6875	839.7500
296	1001	0010	0111	938.7000	899.7000	839.7625
297	1001	0010	1000	938.7125	899.7125	839.7750
298	1001	0010	1001	938.7250	899.7250	839.7875
299	1001	0010	1010	938.7375	899.7375	839.8000
300	1001	0010	1011	938.7500	899.7500	839.8125
301	1001	0010	1100	938.7625	899.7625	839.8250
302	1001	0010	1101	938.7750	899.7750	839.8375
303	1001	0010	1110	938.7875	899.7875	839.8500
304	1001	0010	1111	938.8000	899.8000	839.8625
305	1001	0011	0000	938.8125	899.8125	839.8750
306	1001	0011	0001	938.8250	899.8250	839.8875
307	1001	0011	0010	938.8375	899.8375	839.9000
308	1001	0011	0011	938.8500	899.8500	839.9125
309	1001	0011	0100	938.8625	899.8625	839.9250
310	1001	0011	0101	938.8750	899.8750	839.9375
311	1001	0011	0110	938.8875	899.8875	839.9500
312	1001	0011	0111	938.9000	899.9000	839.9625
313	1001	0011	1000	938.9125	899.9125	839.9750
314	1001	0011	1001	938.9250	899.9250	839.9875
315	1001	0011	1010	938.9375	899.9375	840.0000

Table 8. DIP Switch Settings

FCC Channel Number	System Switch T210	Data Switch		Transmitter Frequency	Receiver Frequency	Local Frequency
		7654	3210			
316	1001	0011	1011	938.9500	899.9500	840.0125
317	1001	0011	1100	938.9625	899.9625	840.0250
318	1001	0011	1101	938.9750	899.9750	840.0375
319	1001	0011	1110	938.9875	899.9875	840.0500
320	1001	0011	1111	939.0000	900.0000	840.0625
321	1001	0100	0000	939.0125	900.0125	840.0750
322	1001	0100	0001	939.0250	900.0250	840.0875
323	1001	0100	0010	939.0375	900.0375	840.1000
324	1001	0100	0011	939.0500	900.0500	840.1125
325	1001	0100	0100	939.0625	900.0625	840.1250
326	1001	0100	0101	939.0750	900.0750	840.1375
327	1001	0100	0110	939.0875	900.0875	840.1500
328	1001	0100	0111	939.1000	900.1000	840.1625
329	1001	0100	1000	939.1125	900.1125	840.1750
330	1001	0100	1001	939.1250	900.1250	840.1875
331	1001	0100	1010	939.1375	900.1375	840.2000
332	1001	0100	1011	939.1500	900.1500	840.2125
333	1001	0100	1100	939.1625	900.1625	840.2250
334	1001	0100	1101	939.1750	900.1750	840.2375
335	1001	0100	1110	939.1875	900.1875	840.2500
336	1001	0100	1111	939.2000	900.2000	840.2625
337	1001	0101	0000	939.2125	900.2125	840.2750
338	1001	0101	0001	939.2250	900.2250	840.2875
339	1001	0101	0010	939.2375	900.2375	840.3000
340	1001	0101	0011	939.2500	900.2500	840.3125
341	1001	0101	0100	939.2625	900.2625	840.3250
342	1001	0101	0101	939.2750	900.2750	840.3375
343	1001	0101	0110	939.2875	900.2875	840.3500
344	1001	0101	0111	939.3000	900.3000	840.3625
345	1001	0101	1000	939.3125	900.3125	840.3750
346	1001	0101	1001	939.3250	900.3250	840.3875
347	1001	0101	1010	939.3375	900.3375	840.4000
348	1001	0101	1011	939.3500	900.3500	840.4125
349	1001	0101	1100	939.3625	900.3625	840.4250
350	1001	0101	1101	939.3750	900.3750	840.4375
351	1001	0101	1110	939.3875	900.3875	840.4500
352	1001	0101	1111	939.4000	900.4000	840.4625
353	1001	0110	0000	939.4125	900.4125	840.4750
354	1001	0110	0001	939.4250	900.4250	840.4875
355	1001	0110	0010	939.4375	900.4375	840.5000
356	1001	0110	0011	939.4500	900.4500	840.5125
357	1001	0110	0100	939.4625	900.4625	840.5250
358	1001	0110	0101	939.4750	900.4750	840.5375
359	1001	0110	0110	939.4875	900.4875	840.5500
360	1001	0110	0111	939.5000	900.5000	840.5625



Table 8. DIP Switch Settings

FCC Channel Number	System Switch T210	Data Switch		Transmitter Frequency	Receiver Frequency	Local Frequency
		7654	3210			
361	1001	0110	1000	939.5125	900.5125	840.5750
362	1001	0110	1001	939.5250	900.5250	840.5875
363	1001	0110	1010	939.5375	900.5375	840.6000
364	1001	0110	1011	939.5500	900.5500	840.6125
365	1001	0110	1100	939.5625	900.5625	840.6250
366	1001	0110	1101	939.5750	900.5750	840.6375
367	1001	0110	1110	939.5875	900.5875	840.6500
368	1001	0110	1111	939.6000	900.6000	840.6625
369	1001	0111	0000	939.6125	900.6125	840.6750
370	1001	0111	0001	939.6250	900.6250	840.6875
371	1001	0111	0010	939.6375	900.6375	840.7000
372	1001	0111	0011	939.6500	900.6500	840.7125
373	1001	0111	0100	939.6625	900.6625	840.7250
374	1001	0111	0101	939.6750	900.6750	840.7375
375	1001	0111	0110	939.6875	900.6875	840.7500
376	1001	0111	0111	939.7000	900.7000	840.7625
377	1001	0111	1000	939.7125	900.7125	840.7750
378	1001	0111	1001	939.7250	900.7250	840.7875
379	1001	0111	1010	939.7375	900.7375	840.8000
380	1001	0111	1011	939.7500	900.7500	840.8125
381	1001	0111	1100	939.7625	900.7625	840.8250
382	1001	0111	1101	939.7750	900.7750	840.8375
383	1001	0111	1110	939.7875	900.7875	840.8500
384	1001	0111	1111	939.8000	900.8000	840.8625
385	1001	1000	0000	939.8125	900.8125	840.8750
386	1001	1000	0001	939.8250	900.8250	840.8875
387	1001	1000	0010	939.8405	900.8405	840.9000
388	1001	1000	0011	939.8500	900.8500	840.9125
389	1001	1000	0100	939.8625	900.8625	840.9250
390	1001	1000	0101	939.8750	900.8750	840.9375
391	1001	1000	0110	939.8875	900.8875	840.9500
392	1001	1000	0111	939.9000	900.9000	840.9625
393	1001	1000	1000	939.9125	900.9125	840.9750
394	1001	1000	1001	939.9250	900.9250	840.9875
395	1001	1000	1010	939.9375	900.8985	841.0000
396	1001	1000	1011	939.9500	900.9500	841.0125
397	1001	1000	1100	939.9625	900.9625	841.0250
398	1001	1000	1101	939.9750	900.9750	841.0375
399	1001	1000	1110	939.9875	900.9875	841.0500

90 2:500                      902.550  
 520 - 1010 . 0000 - 1 000                      903.000

## MODIFICATIONS TO THE ARX 800A TRUNKING LOGIC CONTROLLER

All ARX 800A Trunking Logic Controllers produced as of 7/6/89 include an additional high pass filter (HPF). This hybrid HPF (part # BDEY0334001) corrects a low speed data noise problem that occurs when the ARX 800A is used with the ARX 780 Telephone Interconnect. **The schematics and board view of the ARX 800A in this manual DO NOT show this modification.**

If you are using an ARX 800A Trunking Logic Controller that was produced before 7/6/89, modify it as follows:

1. Carefully remove IC19 (UC1105) from the PCB.
2. Solder an insulate wire to pin 7 of IC19.
3. Solder an insulated wire into the hole in the PCB that pin 7 of IC19 went into.
4. Carefully replace IC19 in the PCB. Have IC19 rise slightly off the PCB to avoid shorting the two wires.
5. Connect the wire from the PCB to pin 4 of the hybrid HPF.
6. Connect the wire coming from pin 7 of IC19 to pin 2 of the hybrid HPF.
7. Connect an insulated wire from pin 1 of the hybrid HPF to pin 8 of IC25 (+Vcc).
8. Connect an insulated wire from pin 3 of the hybrid HPF to pin 4 of IC25 (Gnd).

Make sure to check the ARX 780 Telephone Interconnect for proper deviation and interfacing to the telephone lines. Refer to the ARX 780 service manual for the alignment procedure.

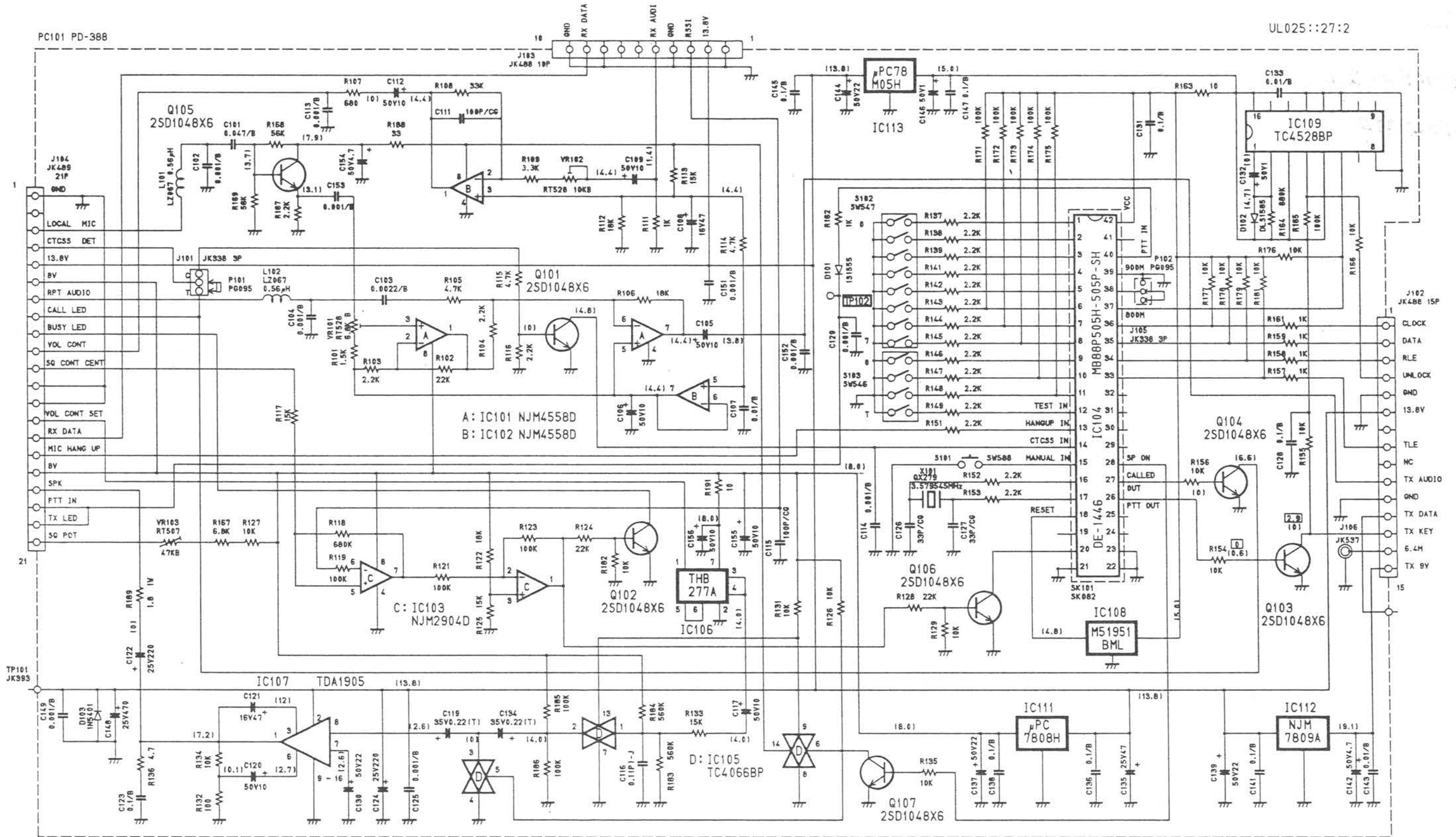

MRS 904  
MOTHERBOARD (PD-388AB)  
SCHEMATIC

PC101 PD-438

Giga Fil  
FT 101  
DFC 2R99 P006 BTD  
FT102  
DFC 5R90 P025 BTD

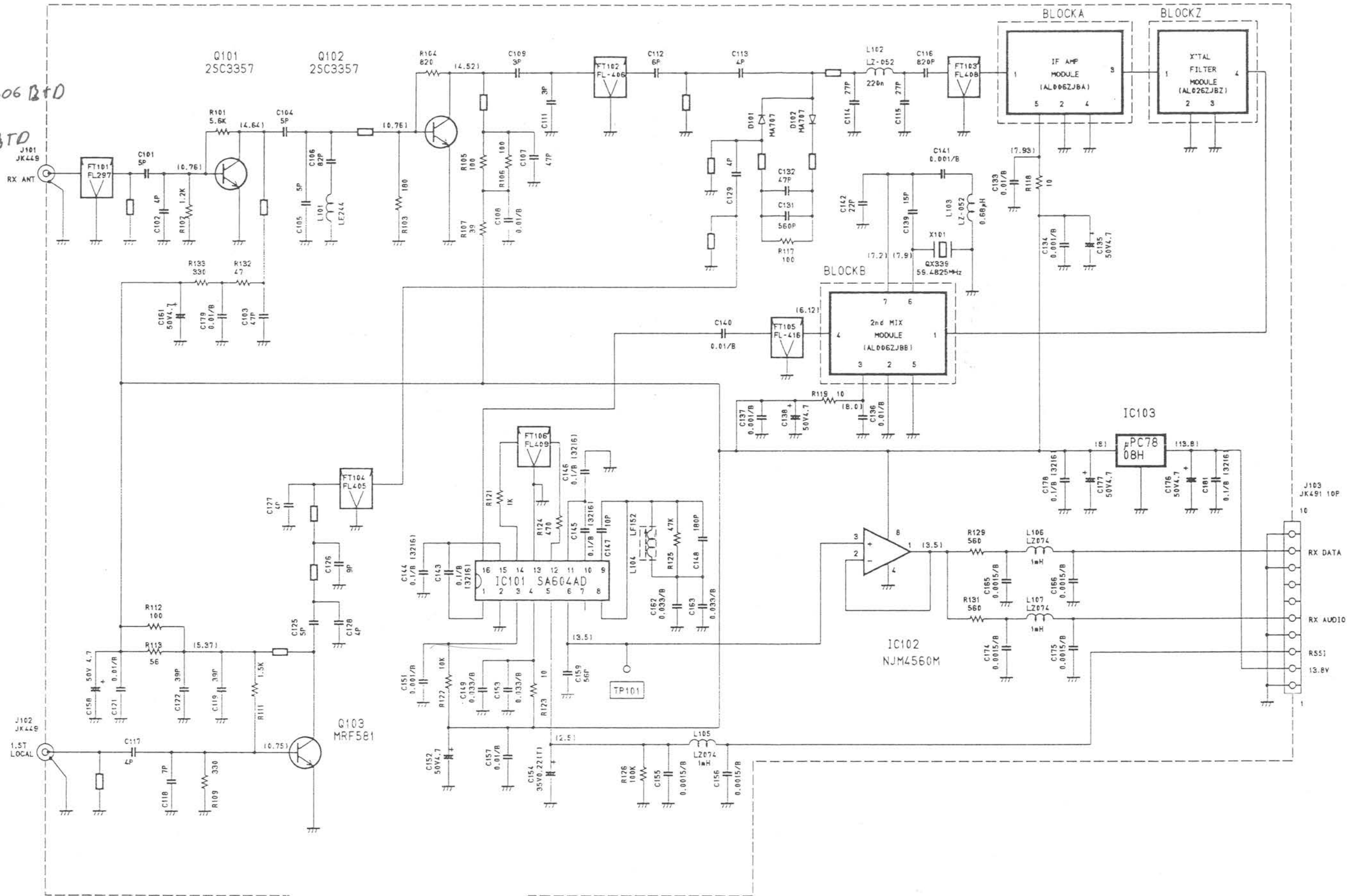

MRS 904  
RECEIVER MODULE (PD-438AA)  
SCHEMATIC

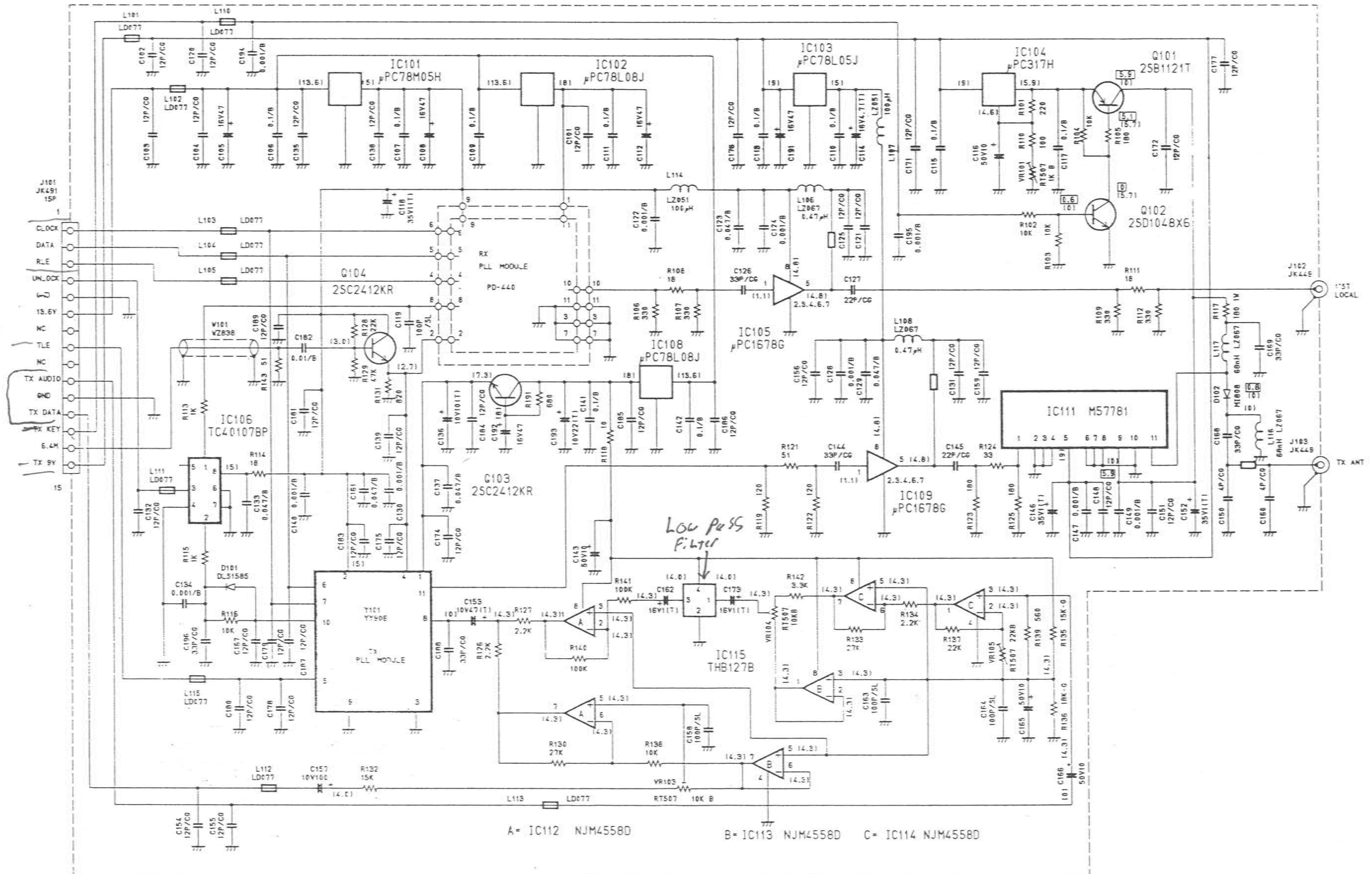

MRS 904 LOCAL OSCILLATOR MODULE (PD-439AA) SCHEMATIC

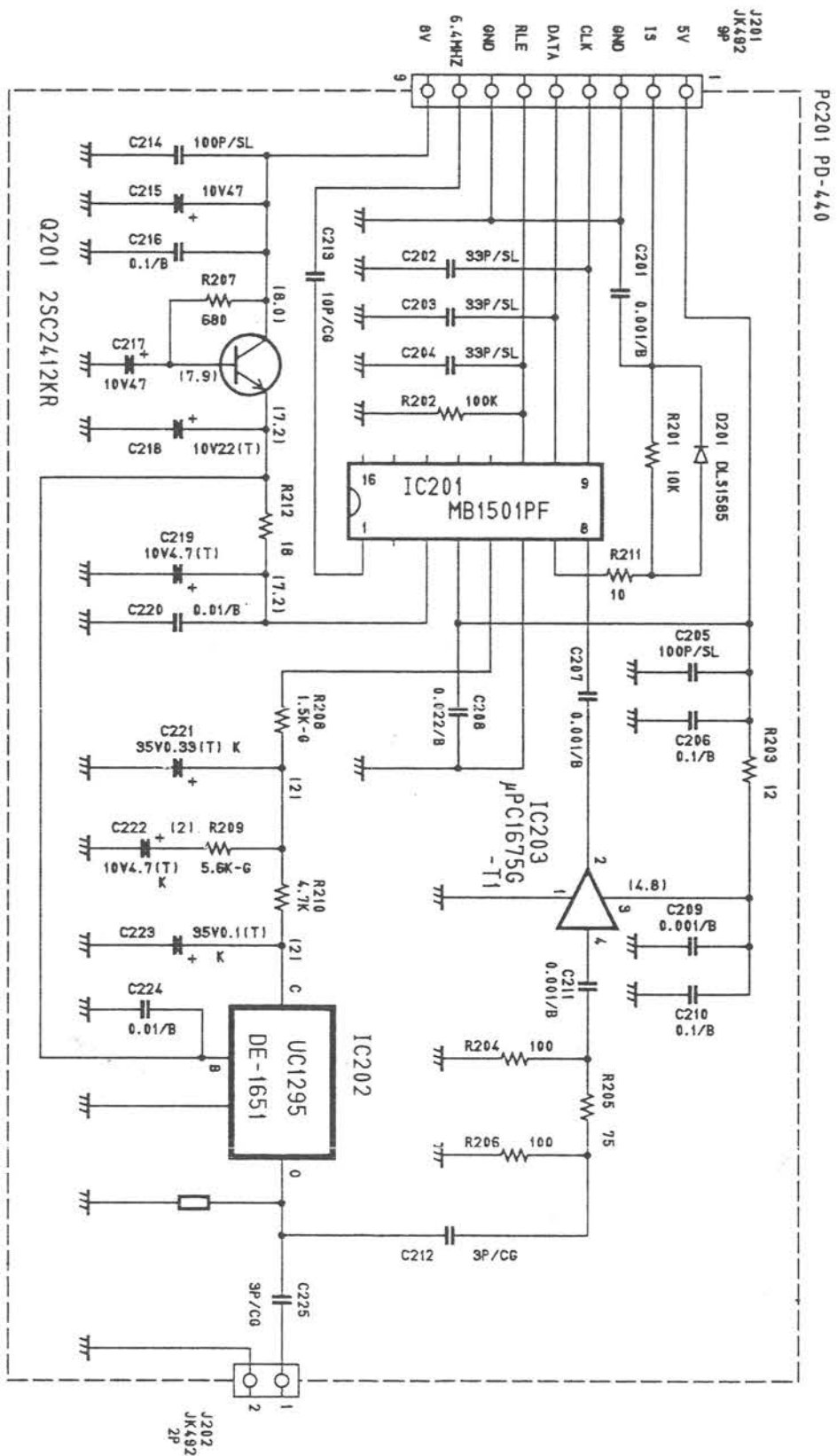

MRS 904  
RX PLL MODULE (PD-440AA)  
SCHEMATIC

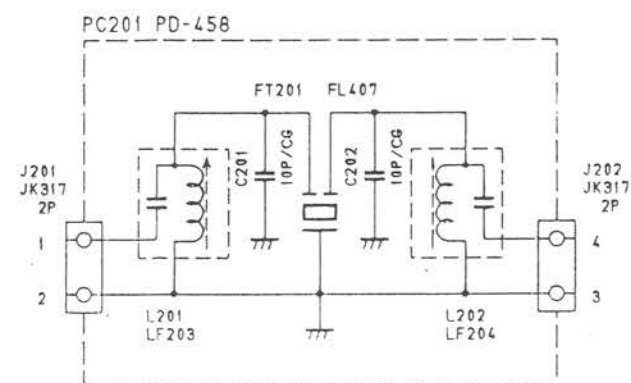

MRS 904  
CRYSTAL FILTER PCB (PD-458AA)  
SCHEMATIC

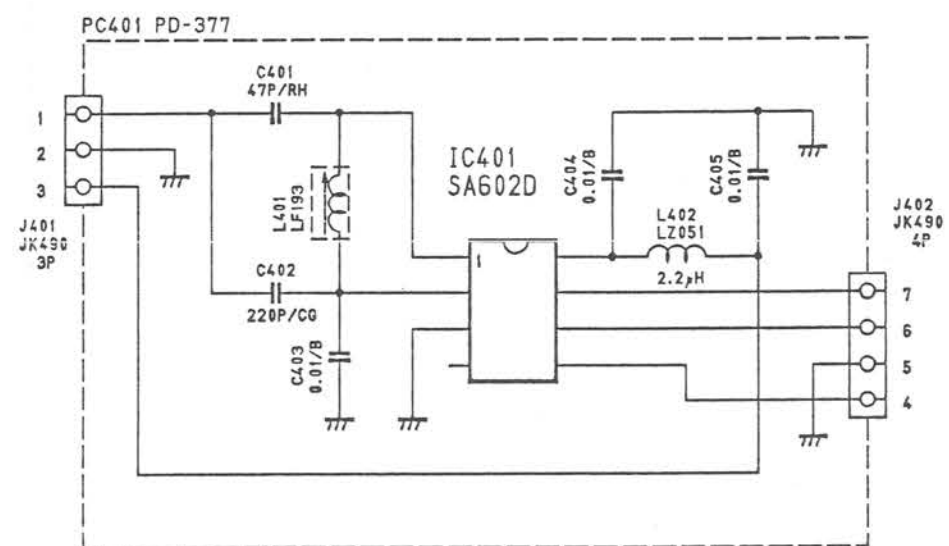

MRS 904  
SECOND MIXER PCB (PD-377AA)  
SCHEMATIC

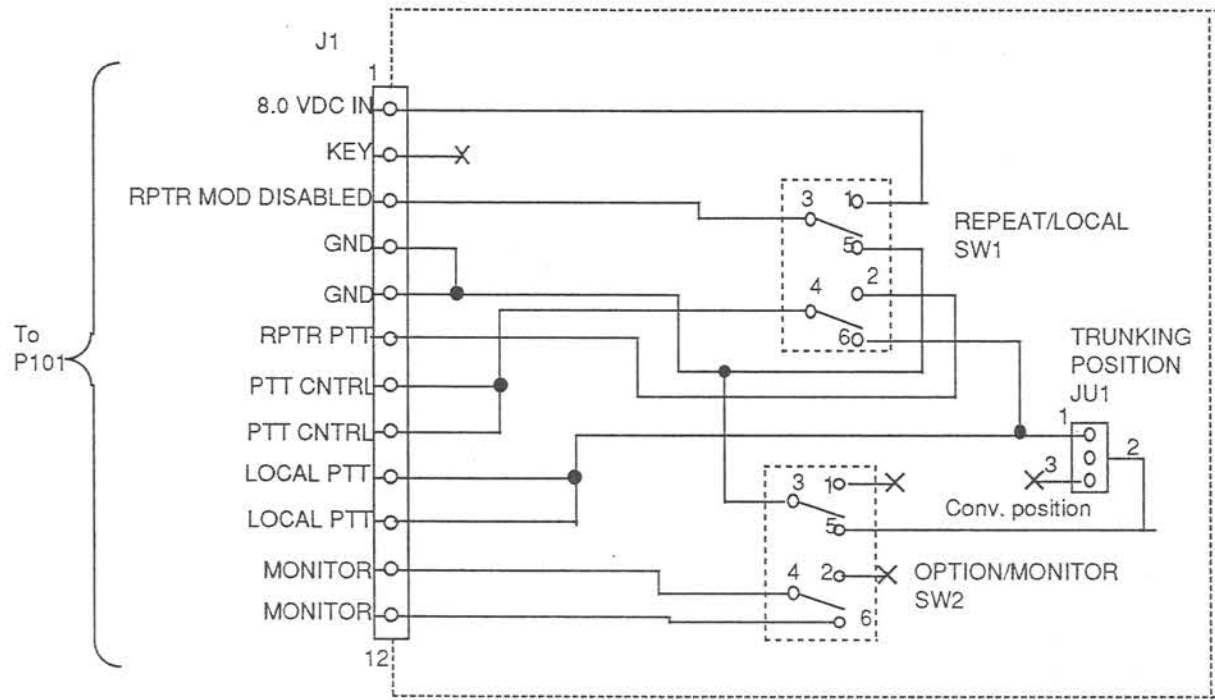

MRS 904  
SWITCH PCB  
SCHEMATIC

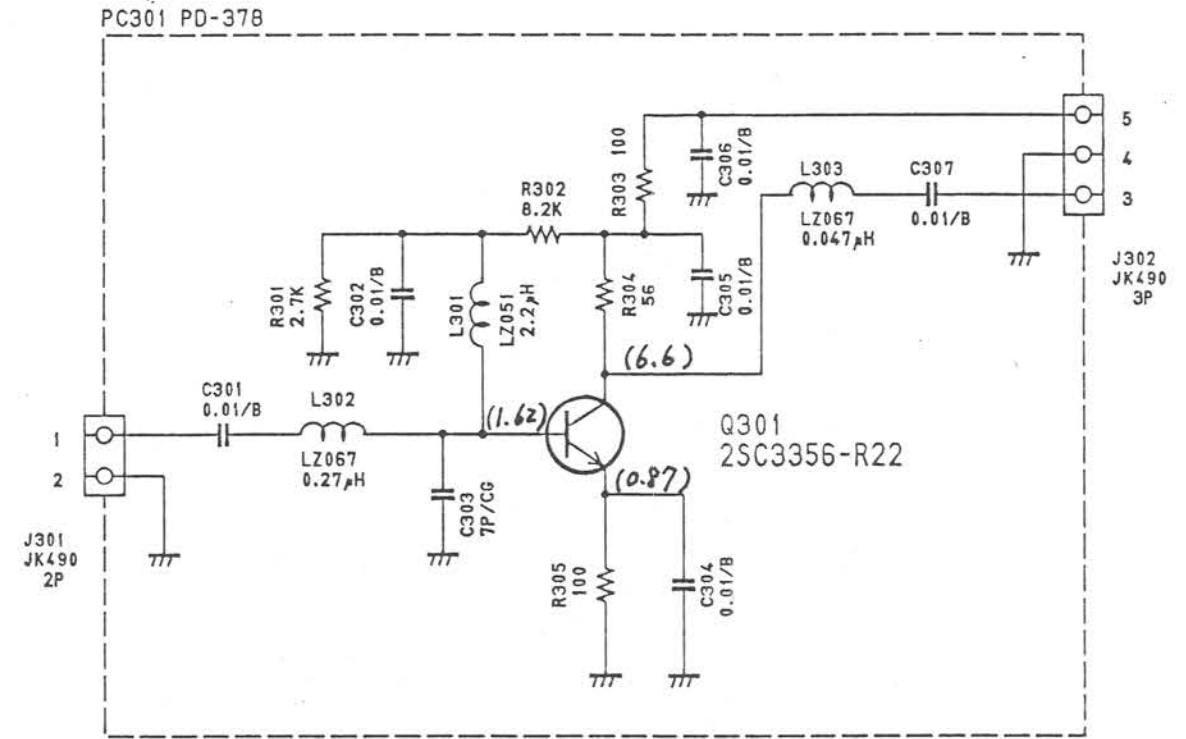

MRS 904  
IF AMP PCB (PD378AA)  
SCHEMATIC

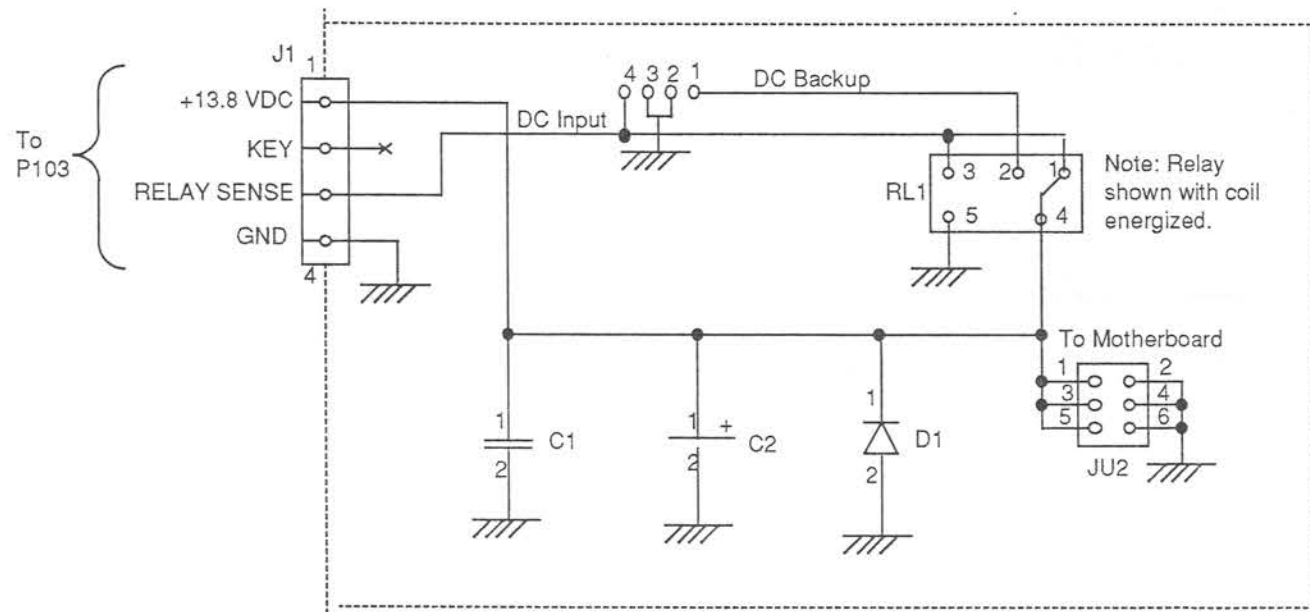

MRS 904  
RELAY PCB  
SCHEMATIC

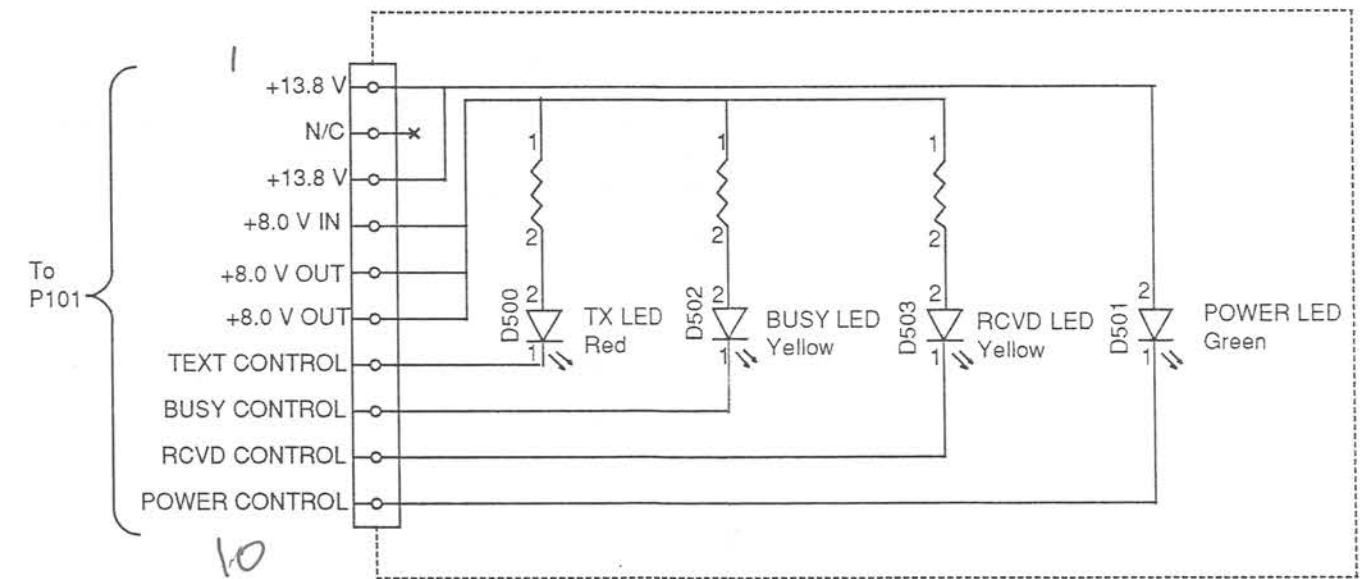

MRS 904  
LED PCB  
SCHEMATIC

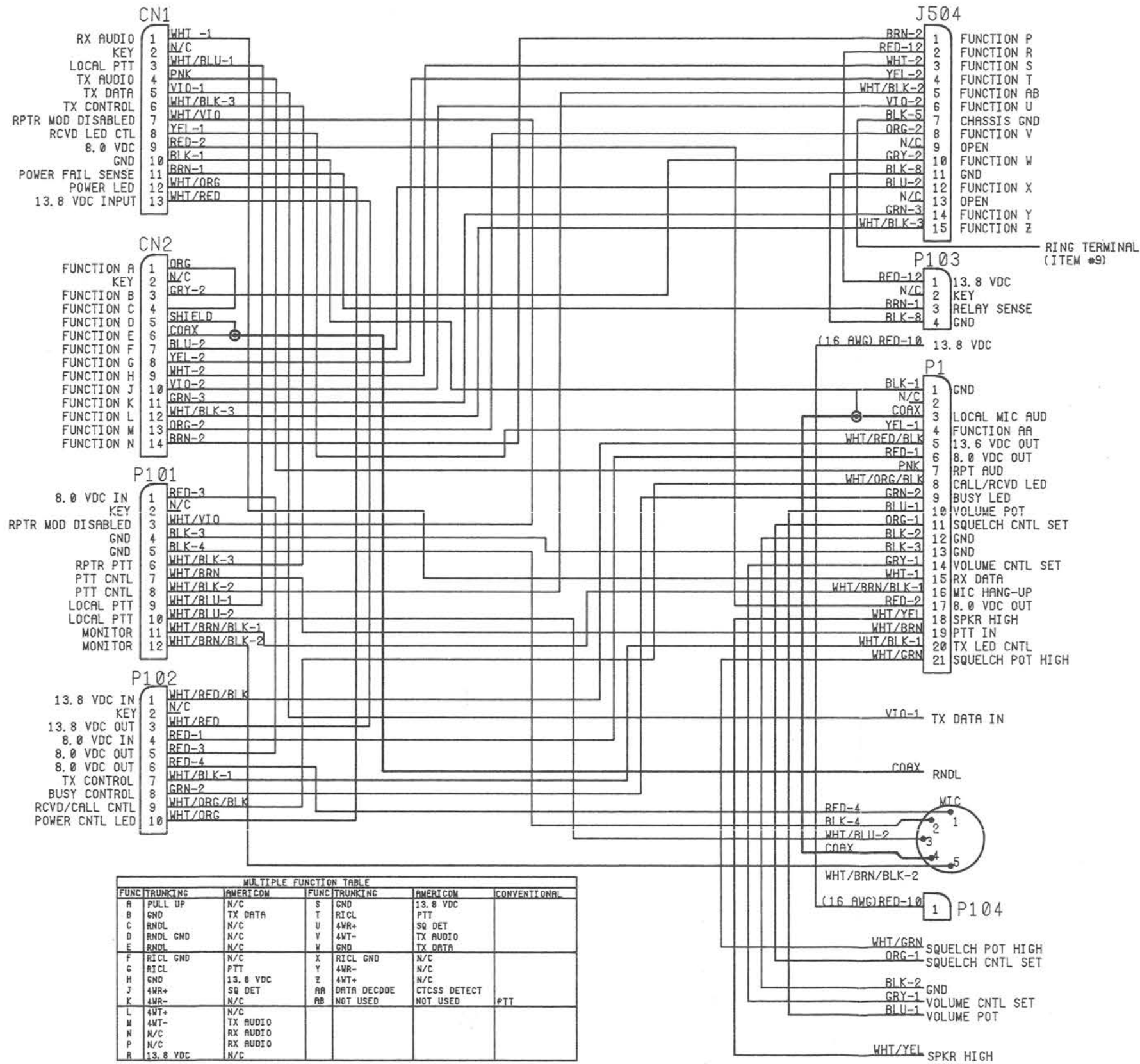

**MRS 904  
CABLE HARNESS  
SCHEMATIC**



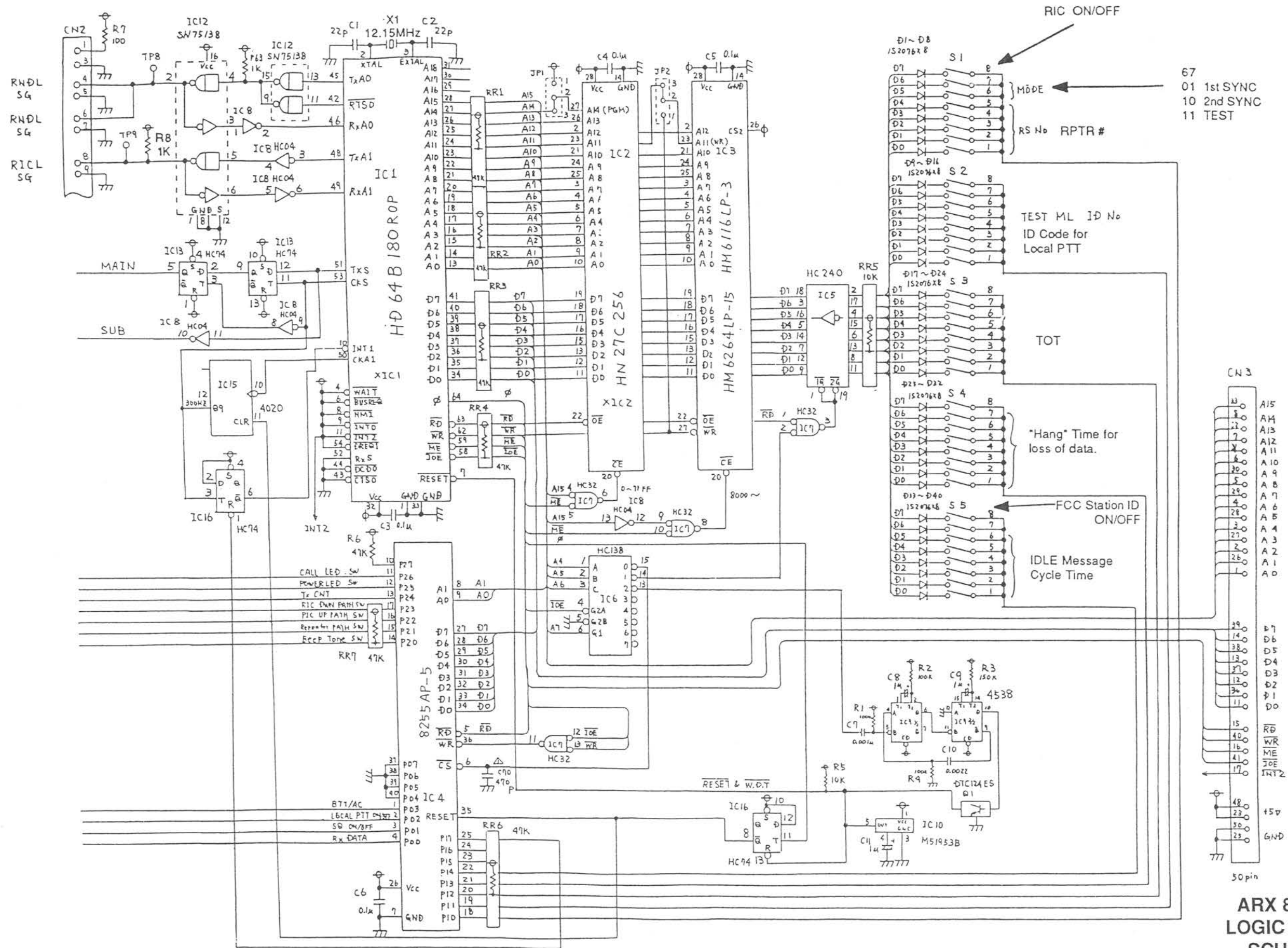

**ARX 800A (MRS 904T ONLY)  
LOGIC BOARD (L-BOARD-01)  
SCHEMATIC (PAGE 1 OF 2)**

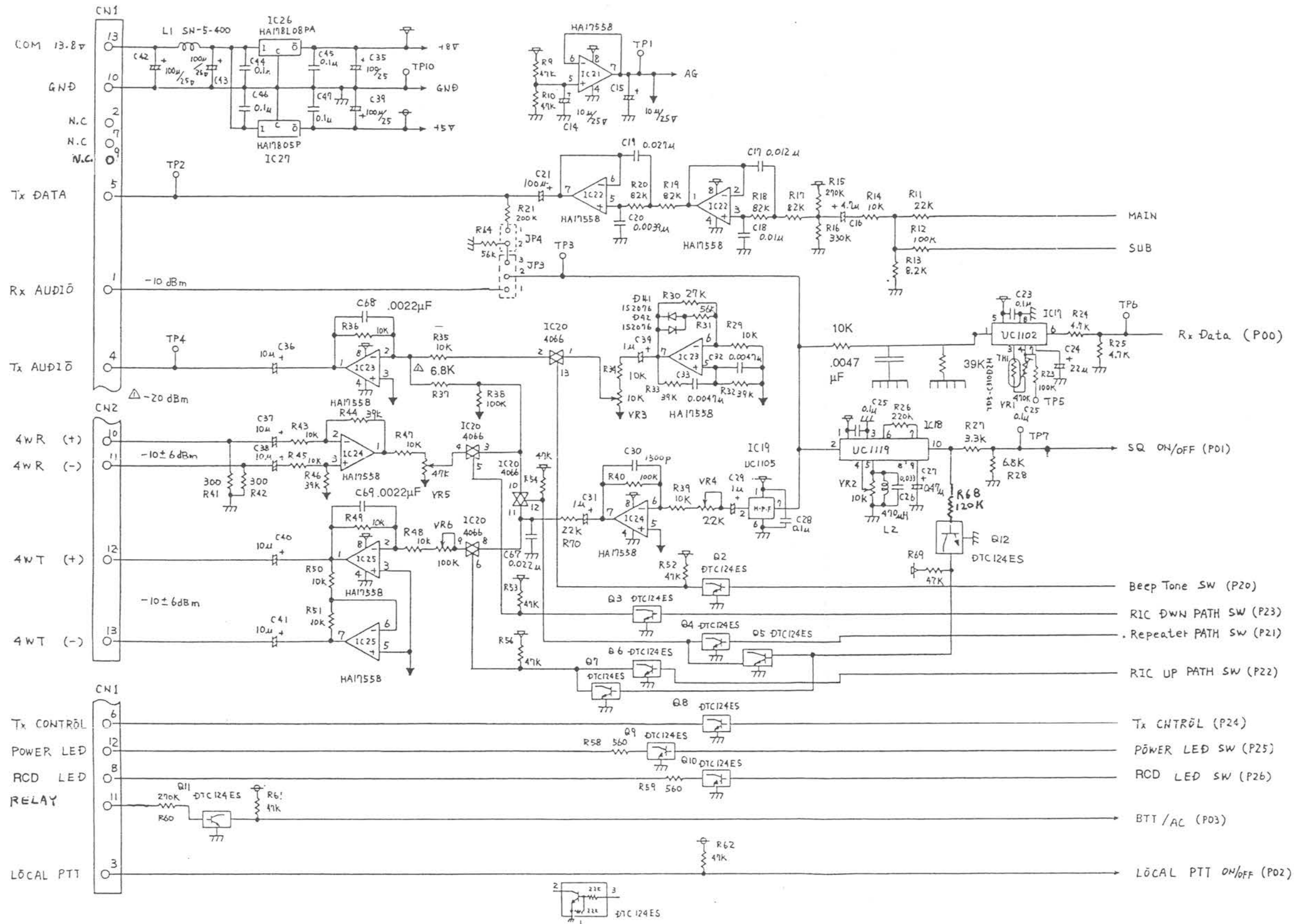

ARX 800A (MRS 904T ONLY)  
 LOGIC BOARD (L-BOARD-01)  
 SCHEMATIC (PAGE 2 OF 2)

PC006 PD-200

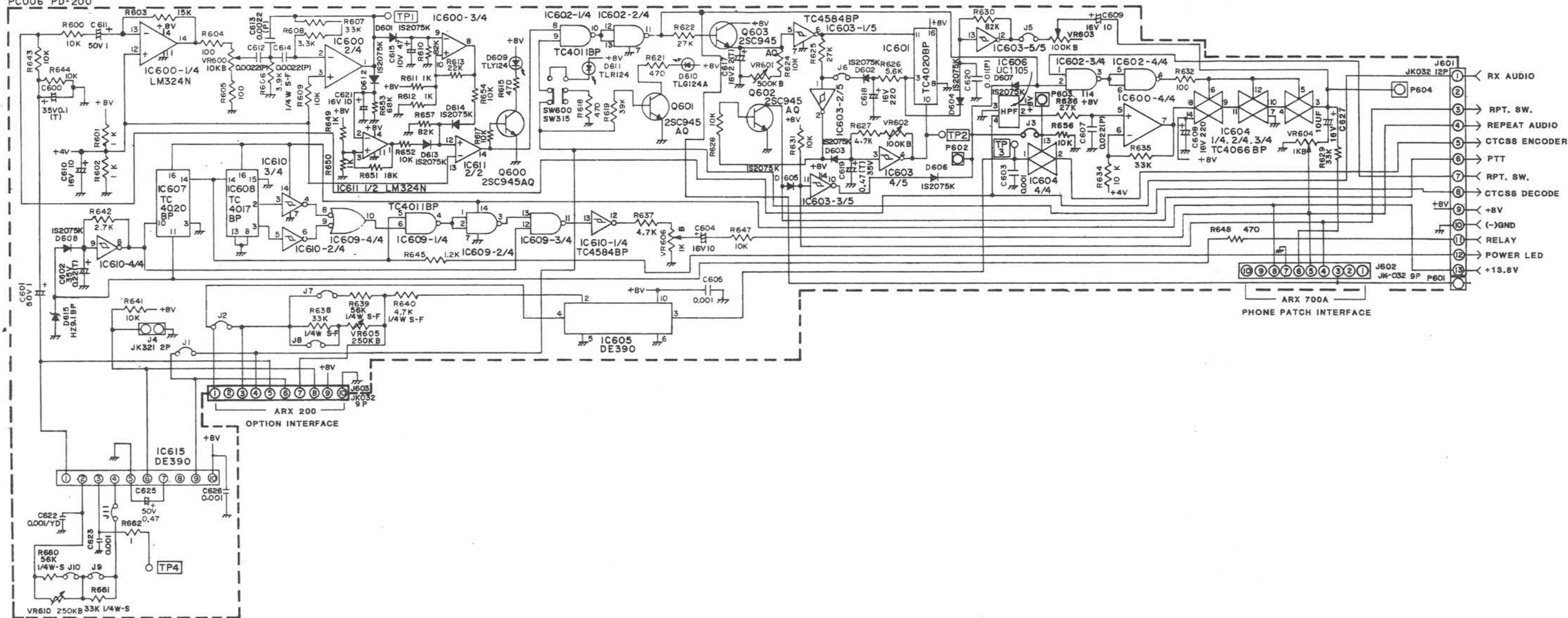

ARX 720 (MRS 904S ONLY)  
CONVENTIONAL LOGIC BOARD (PD-200AB)  
SCHEMATIC

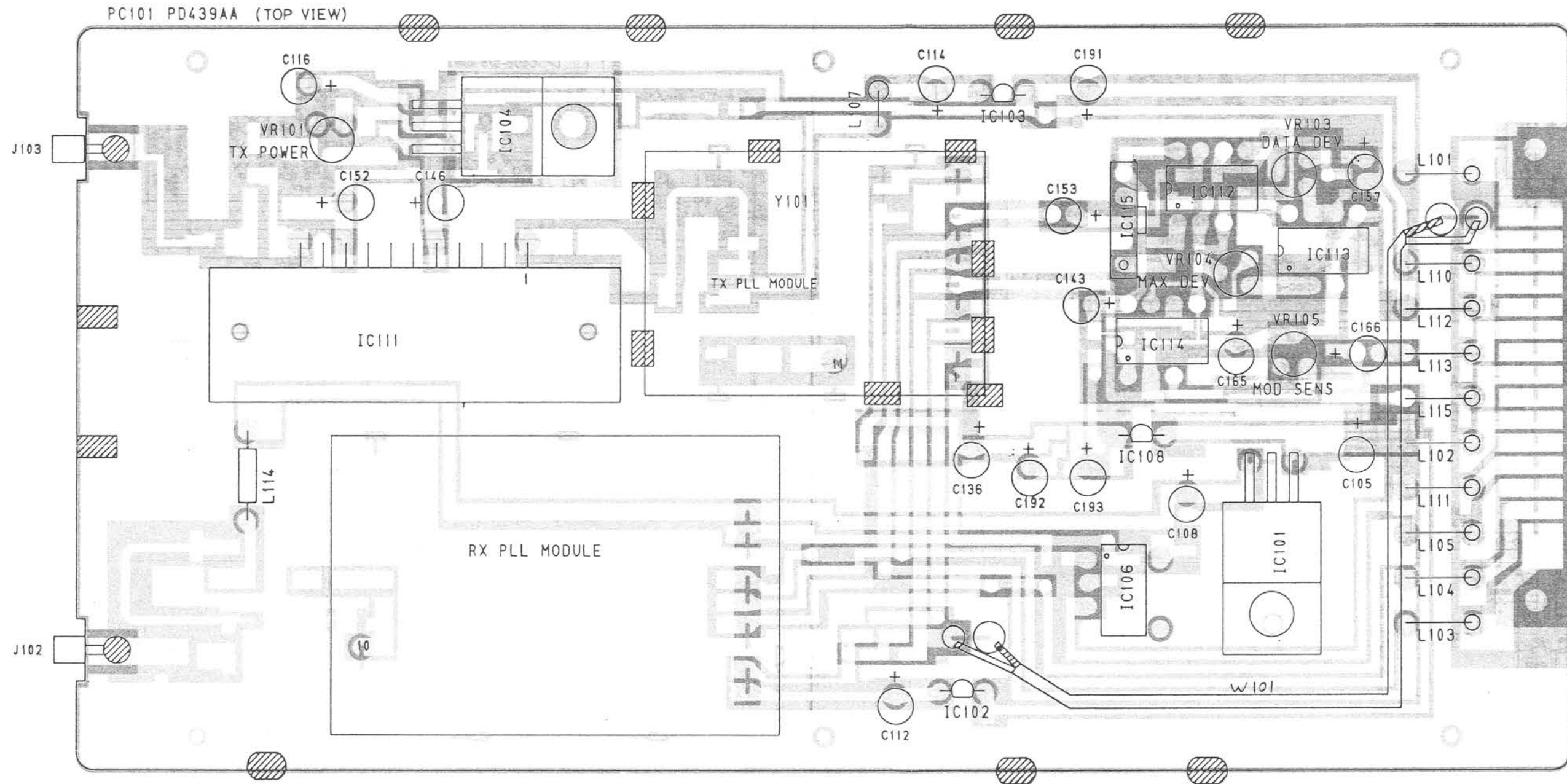

MRS 904  
 LOCAL OSCILLATOR MODULE (PD-439AA)  
 X-RAY VIEW  
 COMPONENT SIDE

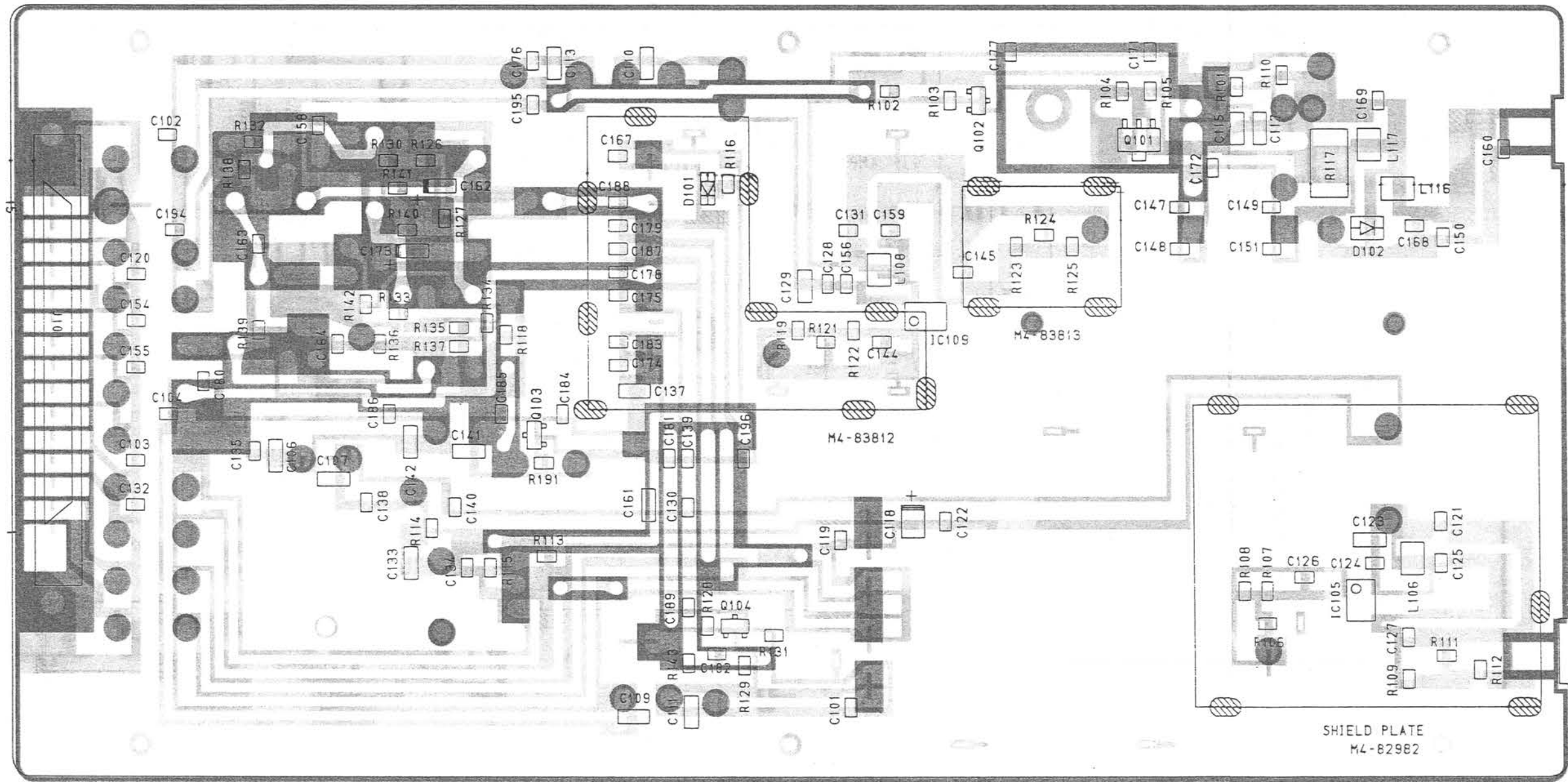

MRS 904  
 LOCAL OSCILLATOR MODULE (PD-439AA)  
 X-RAY VIEW  
 SOLDER SIDE

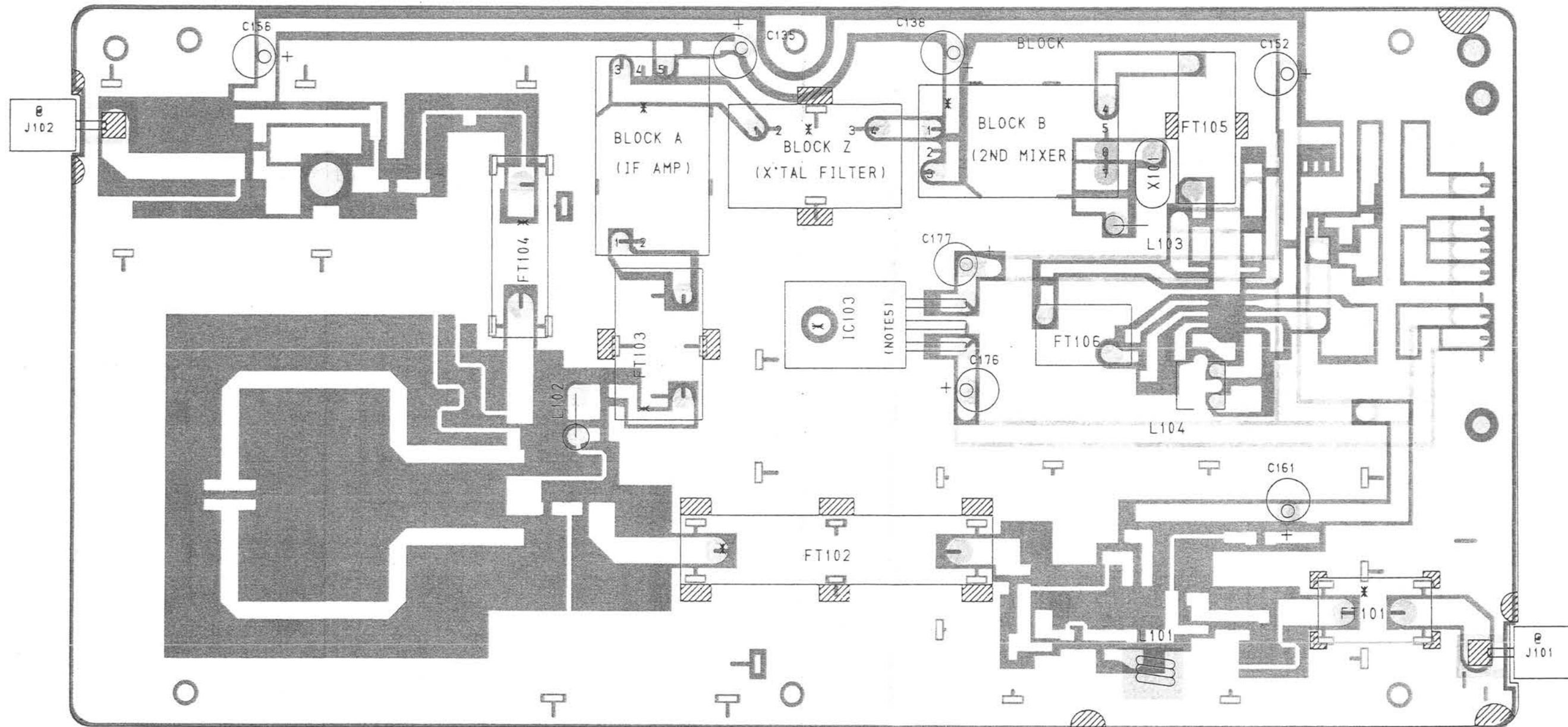

MRS 904  
 RECEIVER MODULE (PD-438AA)  
 X-RAY VIEW  
 COMPONENT SIDE

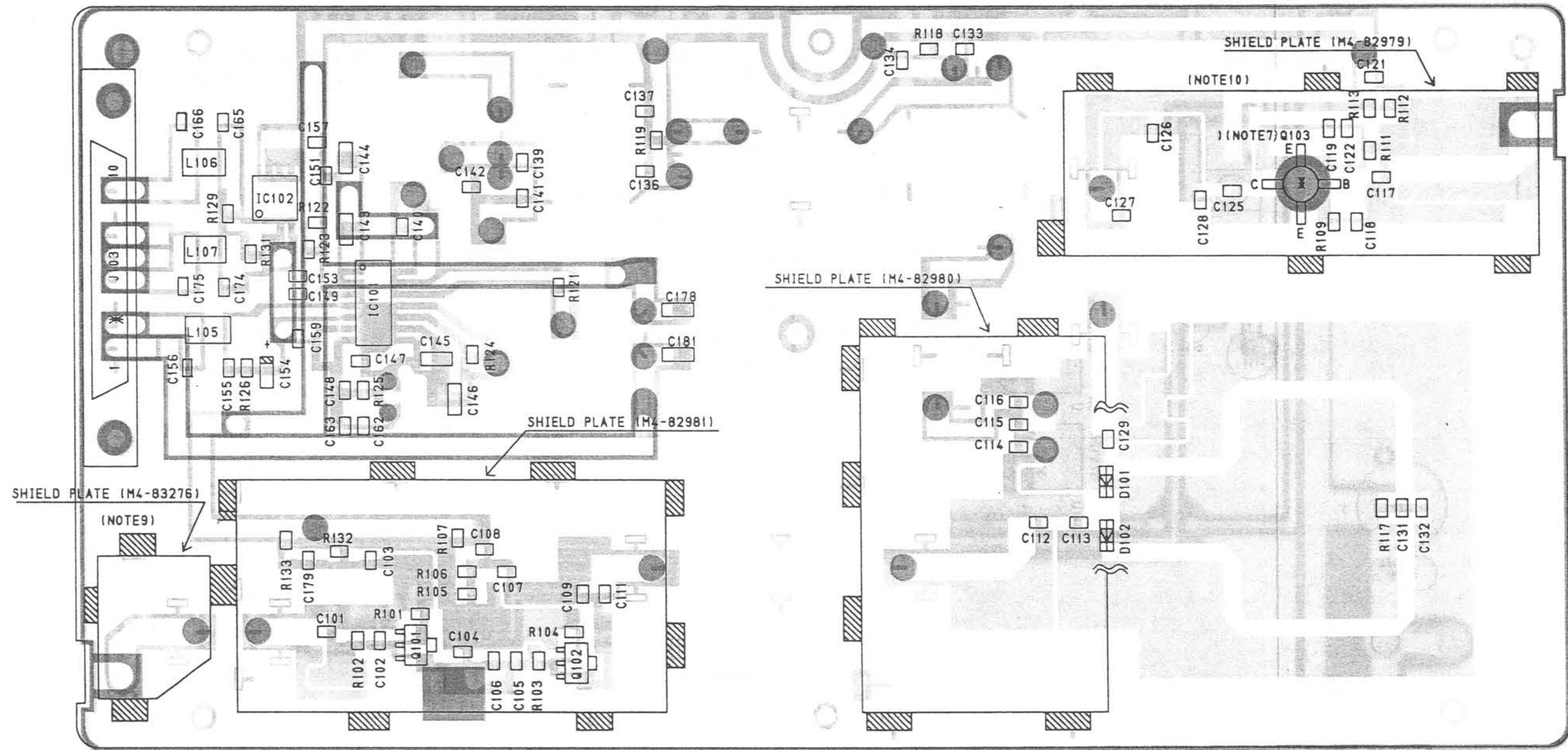

MRS 904  
 RECEIVER MODULE (PD-438AA)  
 X-RAY VIEW  
 SOLDER SIDE

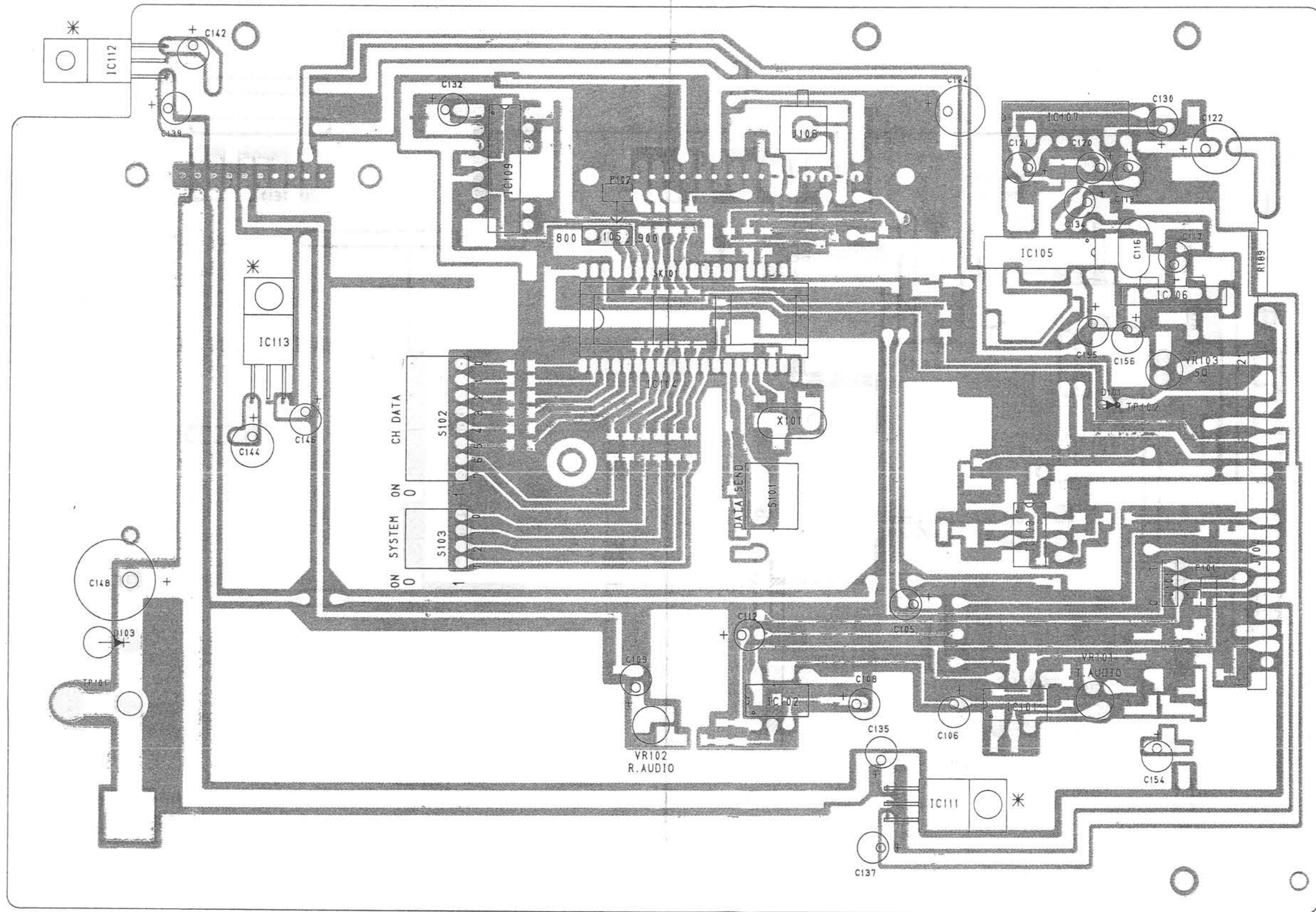

MRS 904  
 MOTHERBOARD (PD-388AB)  
 X-RAY VIEW  
 COMPONENT SIDE



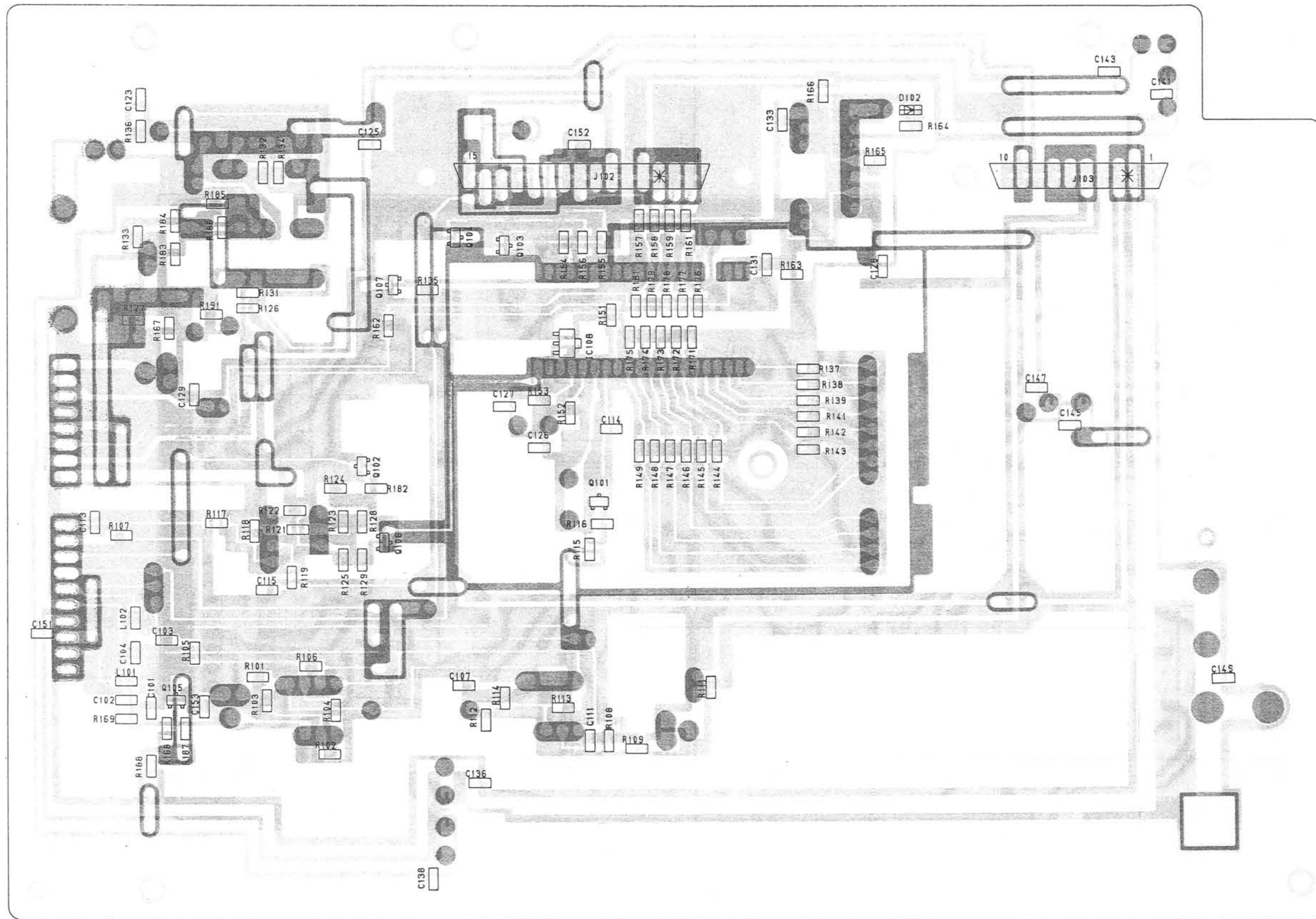

MRS 904  
MOTHERBOARD (PD-388AB)  
X-RAY VIEW  
SOLDER SIDE

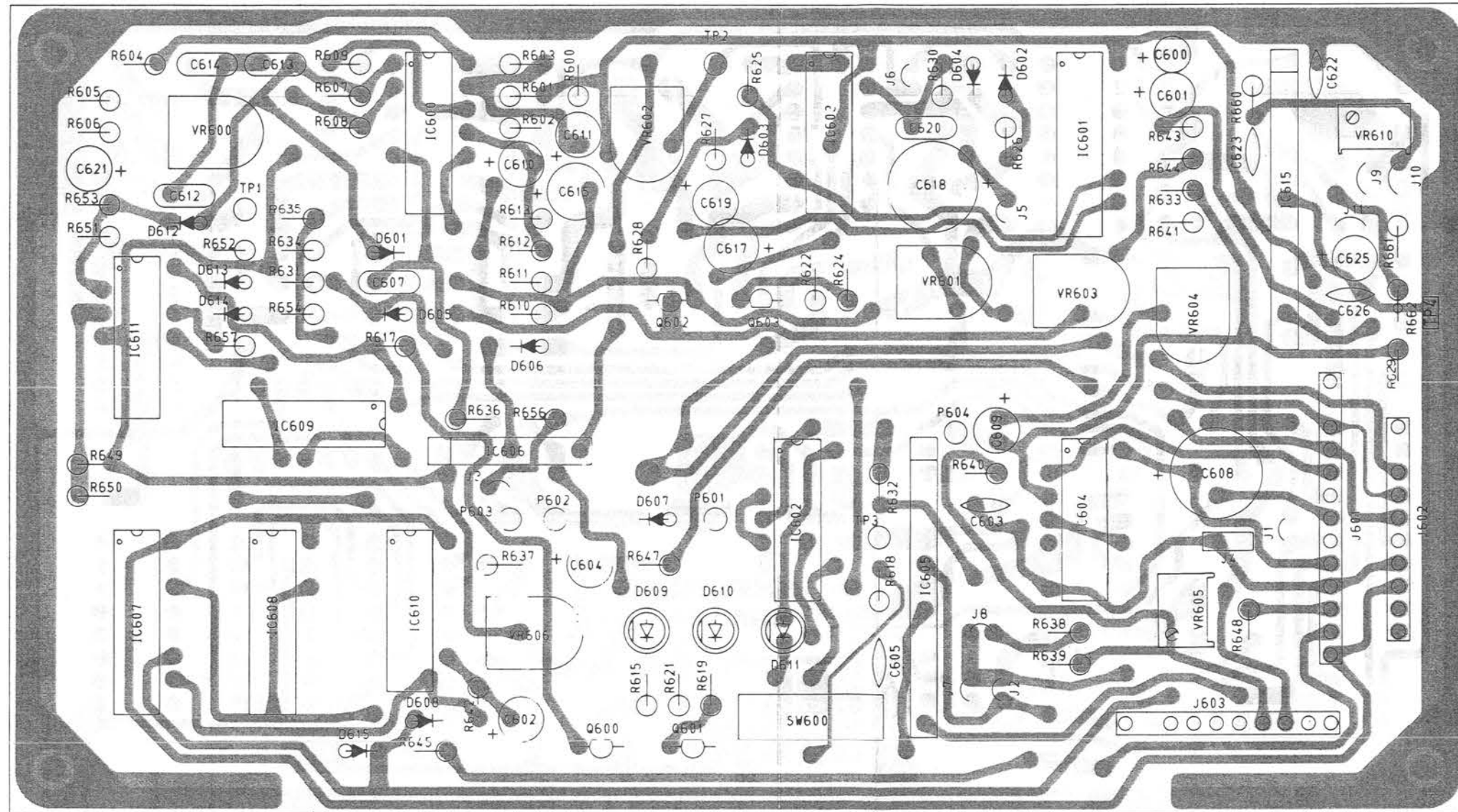

ARX 720 (MRS 904S ONLY)  
 CONVENTIONAL LOGIC BOARD (PD-200AB)  
 X-RAY VIEW  
 COMPONENT SIDE

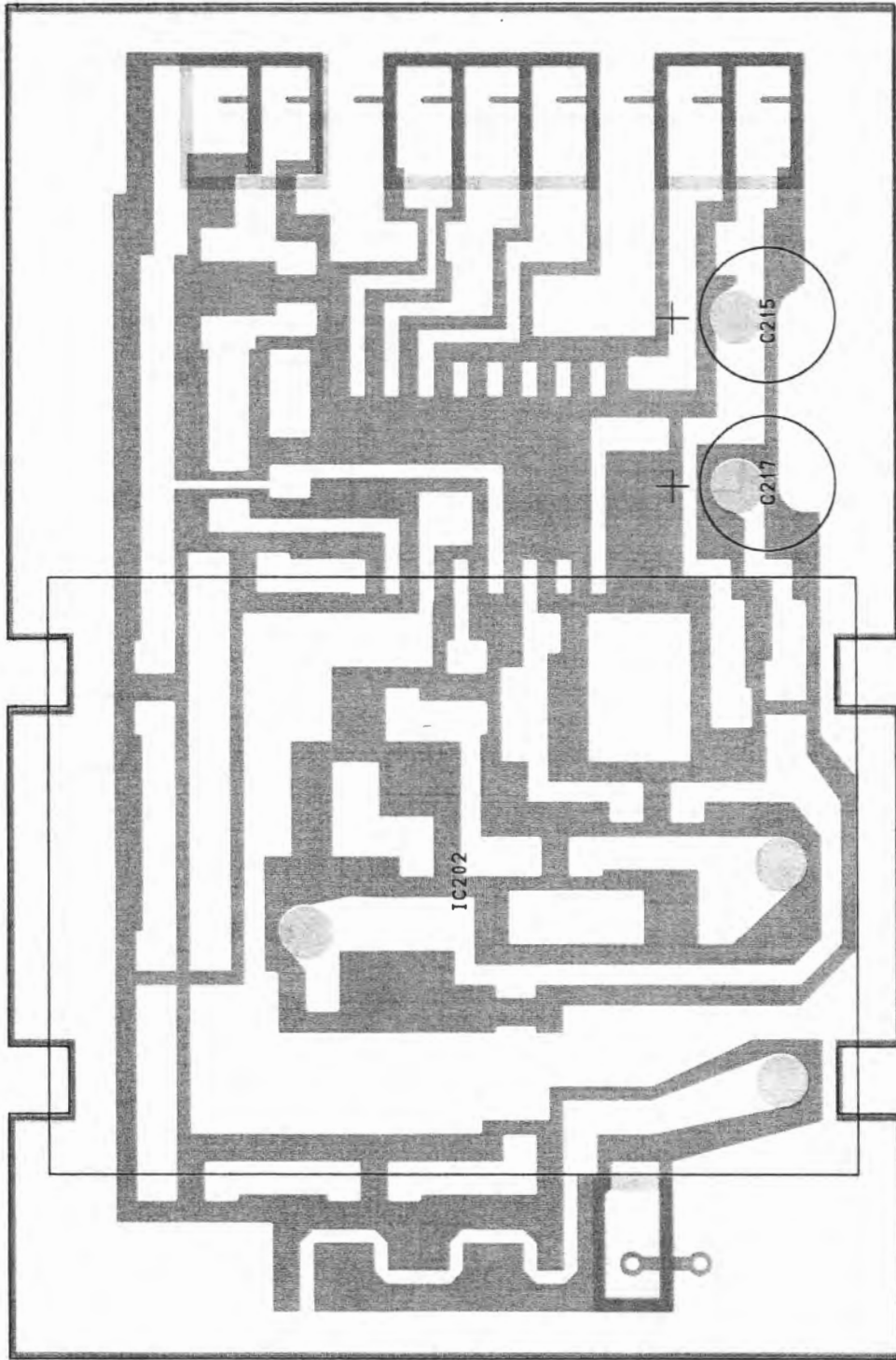

**MRS 904  
RX PLL MODULE (PD-440AA)  
X-RAY VIEW  
COMPONENT SIDE**

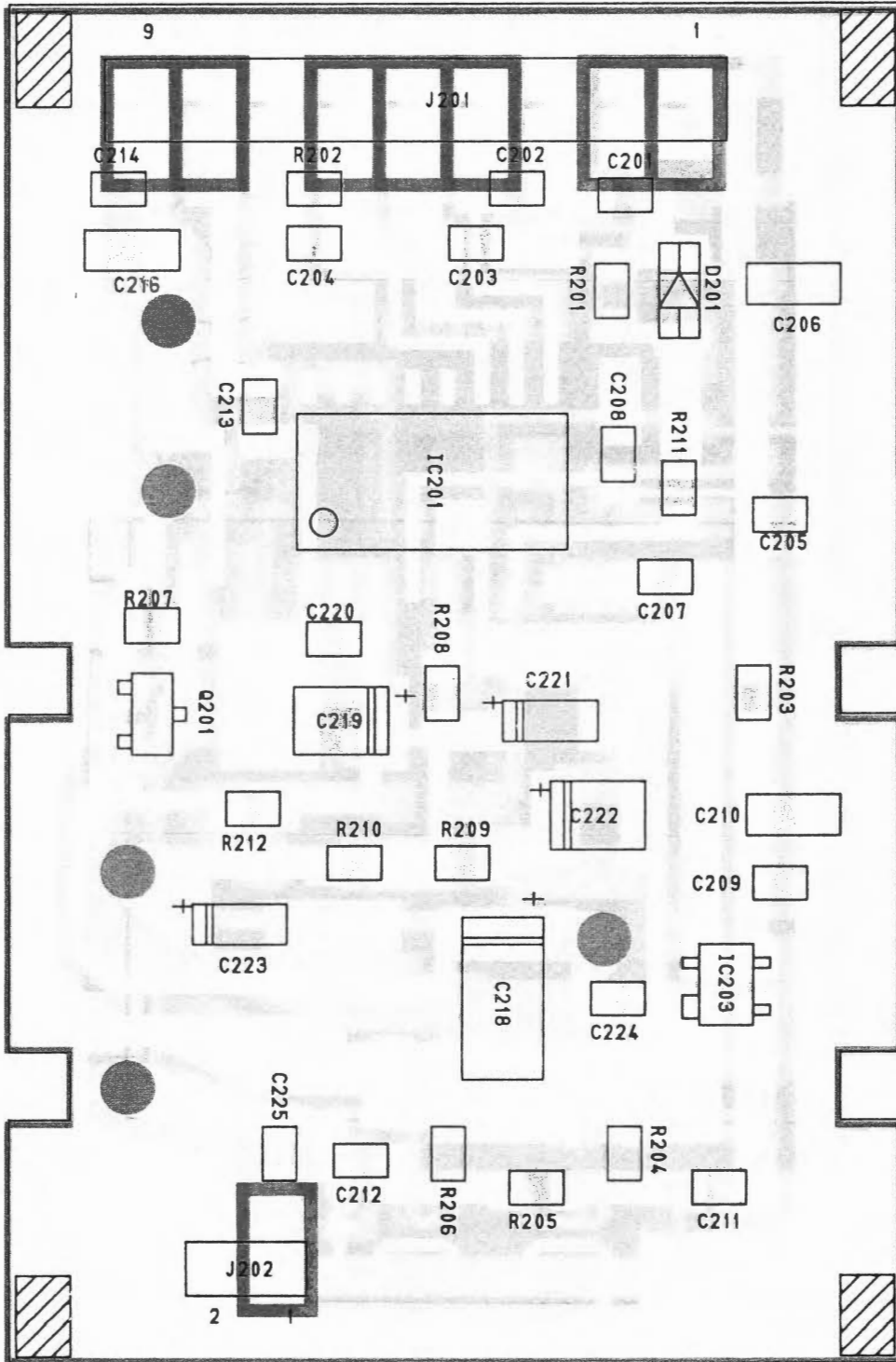

**MRS 904  
 RX PLL MODULE (PD-440AA)  
 X-RAY VIEW  
 SOLDER SIDE**

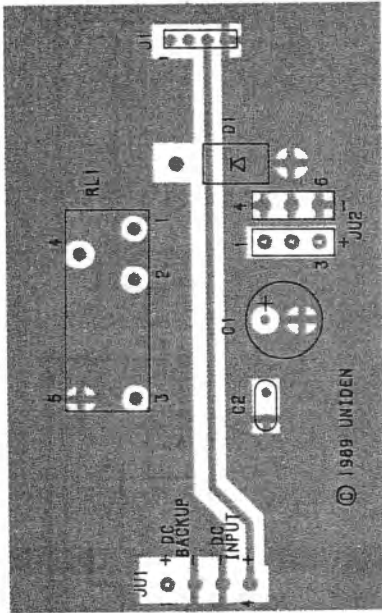

**MRS 904  
RELAY PCB  
X-RAY VIEW  
COMPONENT SIDE**

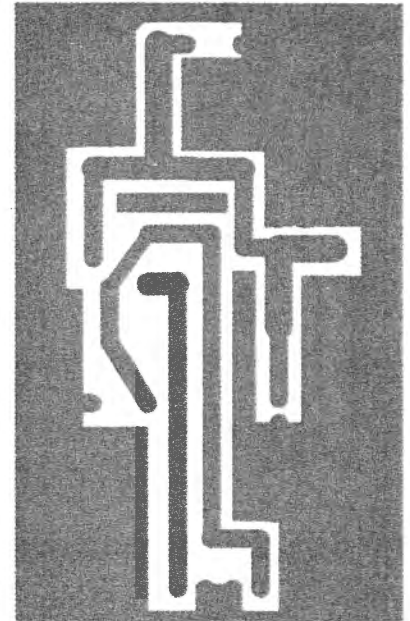

**MRS 904  
RELAY PCB  
X-RAY VIEW  
SOLDER SIDE**

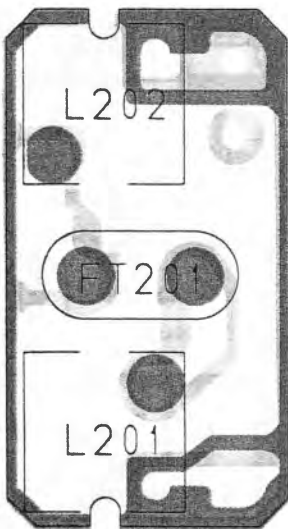

**MRS 904  
CRYSTAL FILTER PCB (PD-458AA)  
X-RAY VIEW  
COMPONENT SIDE**

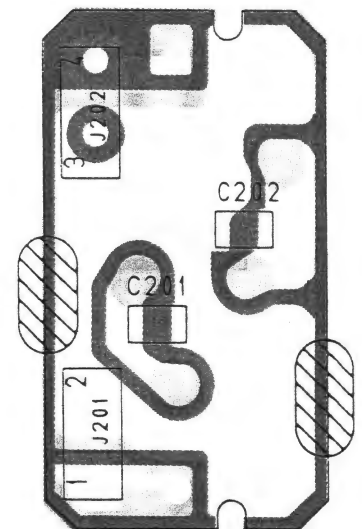

**MRS 904  
CRYSTAL FILTER PCB (PD-458AA)  
X-RAY VIEW  
SOLDER SIDE**

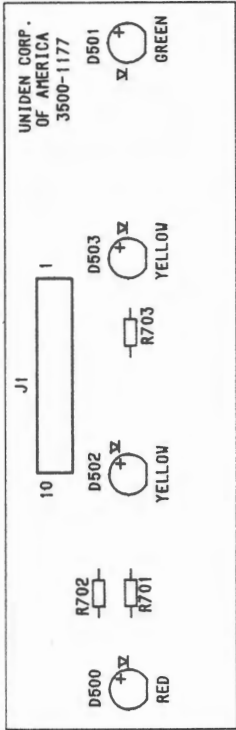

**MRS 904  
LED PCB  
X-RAY VIEW  
COMPONENT SIDE**

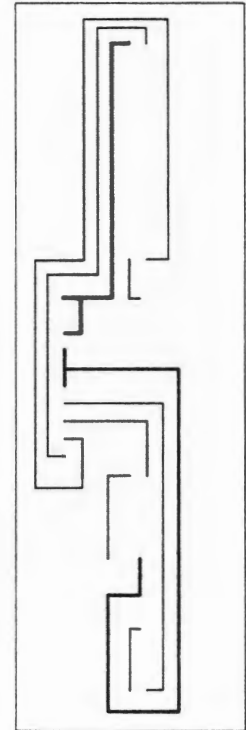

**MRS 904  
LED PCB  
X-RAY VIEW  
SOLDER SIDE**

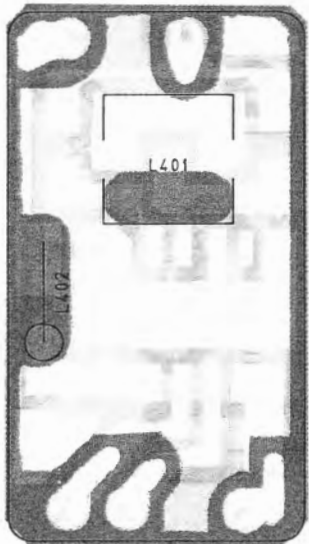

**MRS 904  
SECOND MIXER PCB (PD-377AA)  
X-RAY VIEW  
COMPONENT SIDE**

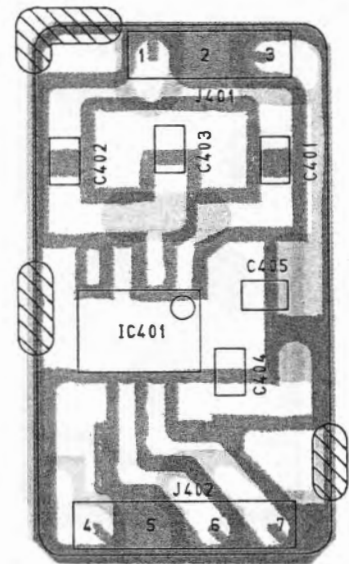

**MRS 904  
SECOND MIXER PCB (PD-377AA)  
X-RAY VIEW  
SOLDER SIDE**

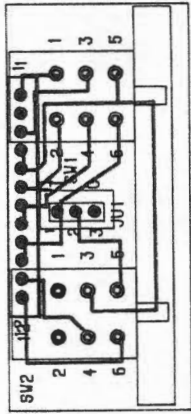

**MRS 904  
SWITCH PCB  
X-RAY VIEW  
COMPONENT SIDE**

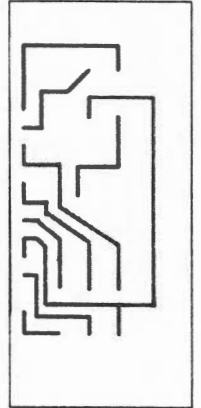

**MRS 904  
SWITCH PCB  
X-RAY VIEW  
SOLDER SIDE**

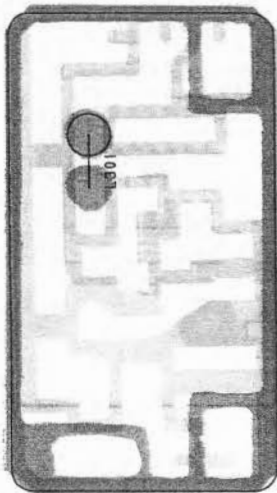

**MRS 904  
IF AMP PCB (PD-378AA)  
X-RAY VIEW  
COMPONENT SIDE**

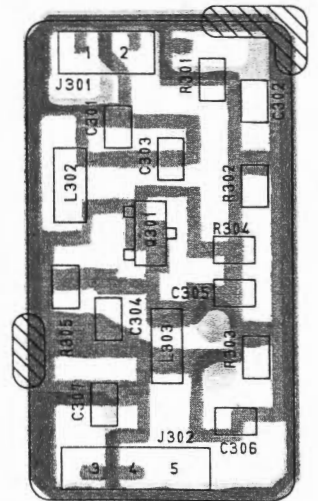

**MRS 904  
IF AMP PCB (PD-378AA)  
X-RAY VIEW  
SOLDER SIDE**

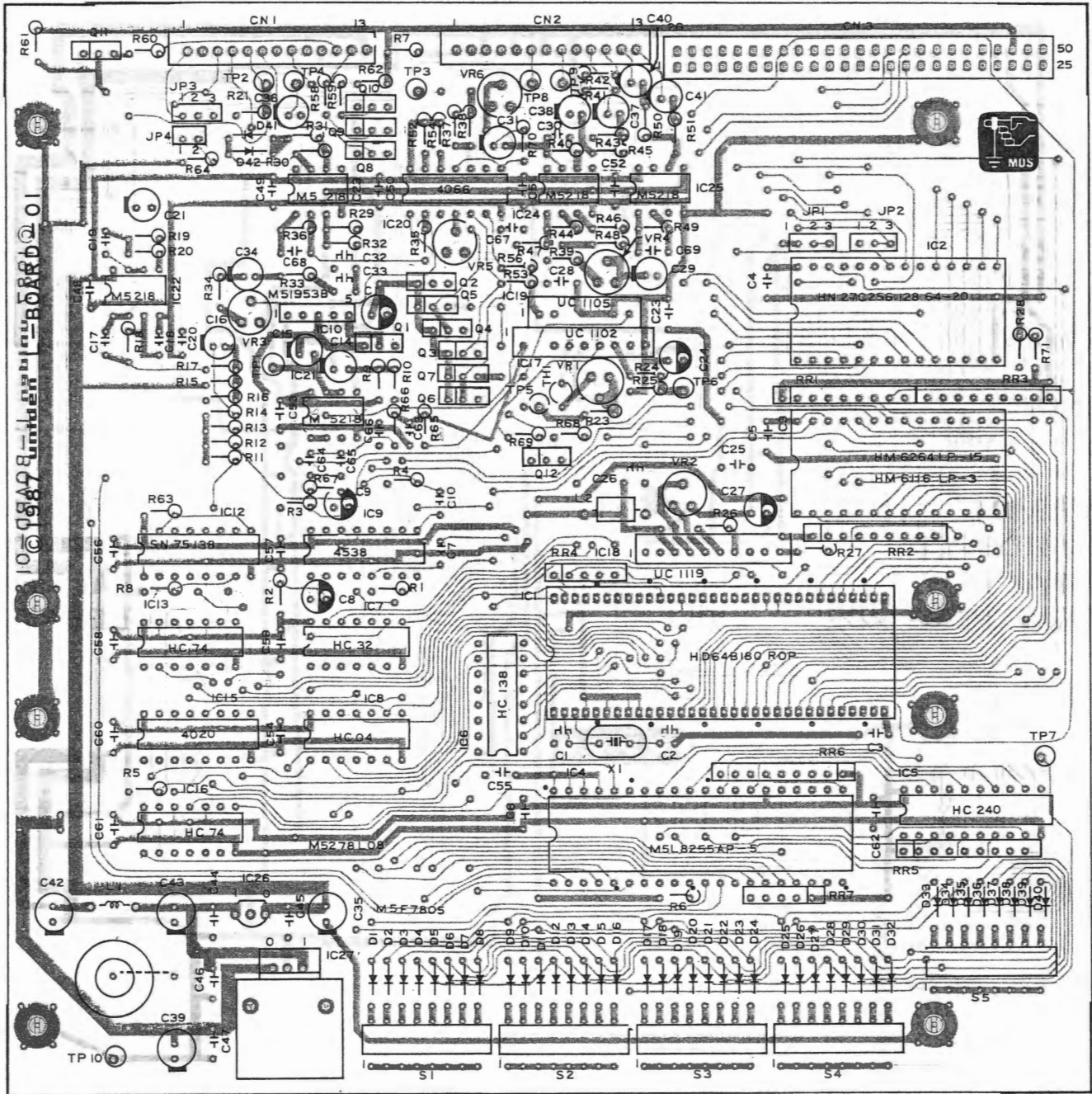

ARX 800A (MRS 904T ONLY)  
 LOGIC BOARD (L-BOARD-01)  
 X-RAY VIEW  
 COMPONENT SIDE



MRS 904  
CABLE HARNESS  
MECHANICAL VIEW

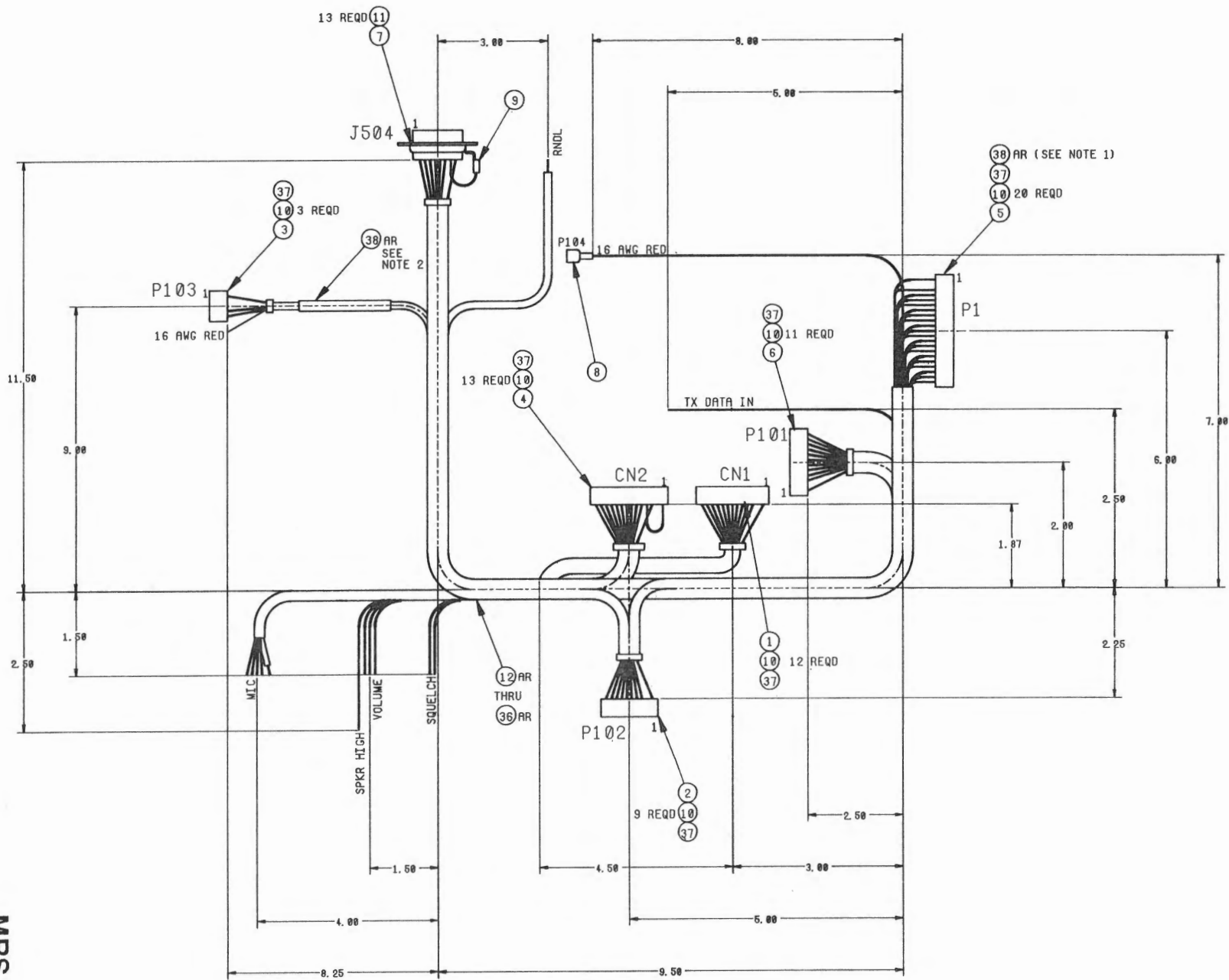

# ELECTRICAL PARTS LIST

## Capacitors

AS = Al Solid	CG = Ceramic Gimmick	MF = Mylar Film	CT = Trimmer
CC = Chip Capacitor	EL = Electrolytic	TT = Tantalum	FT = Feed Thru
CD = Ceramic Disk	SD = Semi-Conductor	TC = Tantalum Chip	

The first code indicates the tolerance of the capacitor:

C = $\pm 0.25$ PF	F = $\pm 1$ PF	J = $\pm 5\%$	M = $\pm 20\%$
D = $\pm 0.5$ PF	G = $\pm 2\%$	K = $\pm 10\%$	Z = +80% -20%

The second code Indicates the variation of capacitance with temperature:

YA = $\pm 5\%$	YF = +30% -38% (-25°C to +85°C)	CJ = $\pm 120$ ppm/°C	
YB = $\pm 10\%$	ZF = +30% -80% (10°C to 70°C)	TH = -470 ppm/°C $\pm 60$ ppm/°C	
YD = +20% -30%	CH = $\pm 60$ ppm/°C	UJ = -750 ppm/°C $\pm 120$ ppm/°C	
YE = +20% -50%	RH = -220 ppm/°C	SL = +350 ppm/°C to -1000 ppm/°C	

## Resistors

CF = Carbon Film	RC = Chip Resistor	RM = Micro Resistor
MF = Metal Film	RT = Trimmer Resistor	RV = Variable Resistor

The last code Indicates the tolerance of the resistor:

F = 1%	J = 5%	K = 10%
--------	--------	---------

## Motherboard (PD-388AB)

### Capacitors

Symbol	Part Number	Description
C101	BCXS814735Z	CC 0.047 $\mu$ F 50V K B Taping
C102	BCXS811025Z	CC 0.001 $\mu$ F 50V K B Taping
C103	BCXS812225Z	CC 0.0022 $\mu$ F 50V K B Taping
C104	BCXS811025Z	CC 0.001 $\mu$ F 50V K B Taping
C105	BCEL811000Z	EL 10 $\mu$ F 50V
C106	BCEL811000Z	EL 10 $\mu$ F 50V
C107	BCXS811035Z	CC 0.01 $\mu$ F 50V K B Taping
C108	BCEL314700Z	EL 47 $\mu$ F 16V
C109	BCEL811000Z	EL 10 $\mu$ F 50V
C111	BCXD811014Z	CC 100 PF 50V J CG Taping
C112	BCEL811000Z	EL 10 $\mu$ F 50V
C113	BCXS811025Z	CC 0.001 $\mu$ F 50V K B Taping
C114	BCXS811025Z	CC 0.001 $\mu$ F 50V K B Taping
C115	BCXD811015Z	CC 100 PF 50V K CG Taping
C116	BCQM121044Z	MF 0.1 $\mu$ F 100V J
C117	BCEL811000Z	EL 10 $\mu$ F 50V
C119	BCSB662285Z	TT 0.22 $\mu$ F 35V K C-089
C120	BCEL811000Z	EL 10 $\mu$ F 50V
C121	BCEL314700Z	EL 47 $\mu$ F 16V
C122	BCEL512210Z	EL 220 $\mu$ F 25V

Symbol	Part Number	Description
C123	BCXS811045Z	CC 0.1 $\mu$ F 50V K B Taping
C124	BCEL512210Z	EL 220 $\mu$ F 25V
C125	BCXS811025Z	CC 0.001 $\mu$ F 50V K B Taping
C126	BCXD813304Z	CC 33 PF 50V J CG(CH) Taping
C127	BCXD813304Z	CC 33 PF 50V J CG(CH) Taping
C128	BCXS811045Z	CC 0.1 $\mu$ F 50V K B Taping
C129	BCXS811025Z	CC 0.001 $\mu$ F 50V K B Taping
C130	BCEL812200Z	EL 22 $\mu$ F 50V
C131	BCXS811045Z	CC 0.1 $\mu$ F 50V K B Taping
C132	BCEL811090Z	EL 1 $\mu$ F 50V
C133	BCXS811035Z	CC 0.01 $\mu$ F 50V K B Taping
C134	BCSB662285Z	TT 0.22 $\mu$ F 35V K C-089
C135	BCEL514700Z	EL 47 $\mu$ F 25V
C136	BCXS811045Z	CC 0.1 $\mu$ F 50V K B Taping
C137	BCEL812200Z	EL 22 $\mu$ F 50V
C138	BCXS811045Z	CC 0.1 $\mu$ F 50V K B Taping
C139	BCEL812200Z	EL 22 $\mu$ F 50V
C141	BCXS811045Z	CC 0.1 $\mu$ F 50V K B Taping
C142	BCEL814790Z	EL 4.7 $\mu$ F 50V
C143	BCXS811035Z	CC 0.01 $\mu$ F 50V K B Taping
C144	BCEL812200Z	EL 22 $\mu$ F 50V
C145	BCXS811045Z	CC 0.1 $\mu$ F 50V K B Taping
C146	BCEL811090Z	EL 1 $\mu$ F 50V
C147	BCXS811045Z	CC 0.1 $\mu$ F 50V K B Taping
C148	BCEL514710Z	EL 470 $\mu$ F 25V
C149	BCXS811025Z	CC 0.001 $\mu$ F 50V K B Taping
C151	BCXS811025Z	CC 0.001 $\mu$ F 50V K B Taping
C152	BCXS811025Z	CC 0.001 $\mu$ F 50V K B Taping
C153	BCXS811025Z	CC 0.001 $\mu$ F 50V K B Taping
C154	BCEL814790Z	EL 4.7 $\mu$ F 50V
C155	BCEL811000Z	EL 10 $\mu$ F 50V
C156	BCEL811000Z	EL 10 $\mu$ F 50V

### Diodes

D101	BDAY0181001	1S1555
D102	BDAY0339001	DLS1585 TPH11
D103	BDAY0245001	1N5401

### Connectors

J101	BJKY0338003	JK-338 68907-003 3P
J102	BJKY0488015	JK-488 15P
J103	BJKY0488010	JK-488 10P
J104	BJKY0489021	JK-489 21P
J105	BJKY0338003	JK-338 68907-003 3P
J106	BJKY0537001	JK-537
P101	BPGY0095001	PG-095 68905-001
P102	BPGY0095001	PG-095 68905-001
SK101	BSKY0082042	SK-082 42P
TP101	BJKY0393001	JK-393

## Coils

Symbol	Part Number	Description
L101	BLZY0067568	LZ-067 0.56 $\mu$ H Taping
L102	BLZY0067568	LZ-067 0.56 $\mu$ H Taping

## Transistors

Q101	BDBD1048661	DB-435 2SD1048-X6 Taping
Q102	BDBD1048661	DB-435 2SD1048-X6 Taping
Q103	BDBD1048661	DB-435 2SD1048-X6 Taping
Q104	BDBD1048661	DB-435 2SD1048-X6 Taping
Q105	BDBD1048661	DB-435 2SD1048-X6 Taping
Q106	BDBD1048661	DB-435 2SD1048-X6 Taping
Q107	BDBD1048661	DB-435 2SD1048-X6 Taping

## Resistors

R101	BRFC181524Z	RC 1.5K 1/8W J Taping
R102	BRFC182234Z	RC 22K 1/8W J Taping
R103	BRFC182224Z	RC 2.2K 1/8W J Taping
R104	BRFC182224Z	RC 2.2K 1/8W J Taping
R105	BRFC184724Z	RC 4.7K 1/8W J Taping
R106	BRFC181834Z	RC 18K 1/8W J Taping
R107	BRFC186814Z	RC 680 1/8W J Taping
R108	BRFC183334Z	RC 33K 1/8W J Taping
R109	BRFC183324Z	RC 3.3K 1/8W J Taping
R111	BRFC181024Z	RC 1K 1/8W J Taping
R112	BRFC181834Z	RC 18K 1/8W J Taping
R113	BRFC181534Z	RC 15K 1/8W J Taping
R114	BRFC184724Z	RC 4.7K 1/8W J Taping
R115	BRFC184724Z	RC 4.7K 1/8W J Taping
R116	BRFC182224Z	RC 2.2K 1/8W J Taping
R117	BRFC181534Z	RC 15K 1/8W J Taping
R118	BRFC186844Z	RC 680K 1/8W J Taping
R119	BRFC181044Z	RC 100K 1/8W J Taping
R121	BRFC181044Z	RC 100K 1/8W J Taping
R122	BRFC181834Z	RC 18K 1/8W J Taping
R123	BRFC181044Z	RC 100K 1/8W J Taping
R124	BRFC182234Z	RC 22K 1/8W J Taping
R125	BRFC181534Z	RC 15K 1/8W J Taping
R126	BRFC181034Z	RC 10K 1/8W J Taping
R127	BRFC181034Z	RC 10K 1/8W J Taping
R128	BRFC182234Z	RC 22K 1/8W J Taping
R129	BRFC181034Z	RC 10K 1/8W J Taping
R131	BRFC181034Z	RC 10K 1/8W J Taping
R132	BRFC181014Z	RC 100 1/8W J Taping
R133	BRFC181534Z	RC 15K 1/8W J Taping
R134	BRFC181034Z	RC 10K 1/8W J Taping
R135	BRFC181034Z	RC 10K 1/8W J Taping
R136	BRFC184794Z	RC 4.7 1/8W J Taping
R137	BRFC182224Z	RC 2.2K 1/8W J Taping
R138	BRFC182224Z	RC 2.2K 1/8W J Taping

Symbol	Part Number	Description
R139	BRFC182224Z	RC 2.2K 1/8W J Taping
R141	BRFC182224Z	RC 2.2K 1/8W J Taping
R142	BRFC182224Z	RC 2.2K 1/8W J Taping
R143	BRFC182224Z	RC 2.2K 1/8W J Taping
R144	BRFC182224Z	RC 2.2K 1/8W J Taping
R145	BRFC182224Z	RC 2.2K 1/8W J Taping
R146	BRFC182224Z	RC 2.2K 1/8W J Taping
R147	BRFC182224Z	RC 2.2K 1/8W J Taping
R148	BRFC182224Z	RC 2.2K 1/8W J Taping
R149	BRFC182224Z	RC 2.2K 1/8W J Taping
R151	BRFC182224Z	RC 2.2K 1/8W J Taping
R152	BRFC182224Z	RC 2.2K 1/8W J Taping
R153	BRFC182224Z	RC 2.2K 1/8W J Taping
R154	BRFC181034Z	RC 10K 1/8W J Taping
R155	BRFC181034Z	RC 10K 1/8W J Taping
R156	BRFC181034Z	RC 10K 1/8W J Taping
R157	BRFC181024Z	RC 1K 1/8W J Taping
R158	BRFC181024Z	RC 1K 1/8W J Taping
R159	BRFC181024Z	RC 1K 1/8W J Taping
R161	BRFC181024Z	RC 1K 1/8W J Taping
R162	BRFC181024Z	RC 1K 1/8W J Taping
R163	BRFC181004Z	RC 10 1/8W J Taping
R164	BRFC186844Z	RC 680K 1/8W J Taping
R165	BRFC181044Z	RC 100K 1/8W J Taping
R166	BRFC181034Z	RC 10K 1/8W J Taping
R167	BRFC186824Z	RC 6.8K 1/8W J Taping
R168	BRFC185634Z	RC 56K 1/8W J Taping
R169	BRFC185634Z	RC 56K 1/8W J Taping
R171	BRFC181044Z	RC 100K 1/8W J Taping
R172	BRFC181044Z	RC 100K 1/8W J Taping
R173	BRFC181044Z	RC 100K 1/8W J Taping
R174	BRFC181044Z	RC 100K 1/8W J Taping
R175	BRFC181044Z	RC 100K 1/8W J Taping
R176	BRFC181034Z	RC 10K 1/8W J Taping
R177	BRFC181034Z	RC 10K 1/8W J Taping
R178	BRFC181034Z	RC 10K 1/8W J Taping
R179	BRFC181034Z	RC 10K 1/8W J Taping
R181	BRFC181034Z	RC 10K 1/8W J Taping
R182	BRFC181034Z	RC 10K 1/8W J Taping
R183	BRFC185644Z	RC 560K 1/8W J Taping
R184	BRFC185644Z	RC 560K 1/8W J Taping
R185	BRFC181044Z	RC 100K 1/8W J Taping
R186	BRFC181044Z	RC 100K 1/8W J Taping
R187	BRFC182224Z	RC 2.2K 1/8W J Taping
R188	BRFC183304Z	RC 33 1/8W J Taping
R189	BRSJ101894Z	MF 1.8 1W J
R191	BRFC181004Z	RC 10 1/8W J Taping

### Switches

Symbol	Part Number	Description
S101	BSWY0588001	SW-588 R66-3816
S102	BSWY0547001	SW-547 SSGM48002A
S103	BSWY0546001	SW-546 SSGM44003A

### Integrated Circuits

IC101	BDEY0145001	NJM4558D
IC102	BDEY0145001	NJM4558D
IC103	BDEY0580001	NJM2904D
IC104	BDEY1446001	MB88P505H-505P-5129
IC105	BDEY0411001	TC4066BP
IC106	BDEY1409001	THB277A
IC107	BDEY0603001	TDA1905
IC108	BDEY0850001	M51951BML
IC109	BDEY1452001	TC4528BP
IC111	BDEY0401001	UPC7808H
IC112	BDEY6154001	NJM7809A
IC113	BDEY0767001	UPC78M05H

### Variable Resistors

VR101	BRTY0528682	RT-528 H0651A012-6.8KB
VR102	BRTY0528103	RT-528 10KB
VR103	BRTY0507473	RT-507 47KB

### Miscellaneous

PC101	BPDY0388AAZ	Motherboard PCB PD-388AB
X101	BQXY0279001	Crystal QX-279 3.579545 MHz

## Receiver Module (PD-438AA, PD-377AA, PD-378AA, and PD-458AA)

### Capacitors

Symbol	Part Number	Description
C101	BCXG815091Z	CC 5 PF 50V C CG Taping
C102	BCXG814091Z	CC 4 PF 50V C CG Taping
C103	BCXG814704Z	CC 47 PF 50V J CG Taping
C104	BCXG815092Z	CC 5 PF 50V D CG Taping
C105	BCXG815092Z	CC 5 PF 50V D CG Taping
C106	BCXG818204Z	CC 82 PF 50V J CG Taping
C107	BCXG814704Z	CC 47 PF 50V J CG Taping
C108	BCXT811035Z	CC 0.01 $\mu$ F 50V K B Taping
C109	BCXG813092Z	CC 3 PF 50V J CG Taping
C111	BCXG813092Z	CC 3 PF 50V J CG Taping
C112	BCXG816092Z	CC 6 PF 50V D CG Taping
C113	BCXG814091Z	CC 4 PF 50V C CG Taping
C114	BCXG812704Z	CC 27 PF 50V J CG Taping
C115	BCXG812704Z	CC 27 PF 50V J CG Taping
C116	BCXG818214Z	CC 820 PF 50V J CG Taping
C117	BCXG814091Z	CC 4 PF 50V C CG Taping
C118	BCXG817092Z	CC 7 PF 50V D CG Taping
C119	BCXG813904Z	CC 39 PF 50V J CG Taping
C121	BCXT811035Z	CC 0.01 $\mu$ F 50V K B Taping
C122	BCXG813904Z	CC 39 PF 50V J CG Taping

Symbol	Part Number	Description
C125	BCXG815092Z	CC 5 PF 50V D CG Taping
C126	BCXG819092Z	CC 9 PF 50V D CG Taping
C127	BCXG814091Z	CC 4 PF 50V C CG Taping
C128	BCXG814091Z	CC 4 PF 50V C CG Taping
C129	BCXG814091Z	CC 4 PF 50V C CG Taping
C131	BCXG815614Z	CC 560 PF 50V J CG Taping
C132	BCXG814704Z	CC 47 PF 50V J CG Taping
C133	BCXT811035Z	CC 0.01 $\mu$ F 50V K B Taping
C134	BCXT811025Z	CC 0.001 $\mu$ F 50V K B Taping
C135	BCEL814790Z	EL 4.7 $\mu$ F 50V
C136	BCXT811035Z	CC 0.01 $\mu$ F 50V K B Taping
C137	BCXT811025Z	CC 0.001 $\mu$ F 50V K B Taping
C138	BCEL814790Z	EL 4.7 $\mu$ F 50V
C139	BCXG811504Z	CC 15 PF 50V J CG Taping
C140	BCXT811035Z	CC 0.01 $\mu$ F 50V K B Taping
C141	BCXT811025Z	CC 0.001 $\mu$ F 50V K B Taping
C142	BCXG812204Z	CC 22 PF 50V J CG Taping
C143	BCXS811045Z	CC 0.1 $\mu$ F 50V K B Taping
C144	BCXS811045Z	CC 0.1 $\mu$ F 50V K B Taping
C145	BCXS811045Z	CC 0.1 $\mu$ F 50V K B Taping
C146	BCXS811045Z	CC 0.1 $\mu$ F 50V K B Taping
C147	BCXG811002Z	CC 10 PF 50V D CG Taping
C148	BCXG811814Z	CC 180 PF 50V J CG Taping
C149	BCXT813335Z	CC 0.033 $\mu$ F 50V K B Taping
C151	BCXT811025Z	CC 0.001 $\mu$ F 50V K B Taping
C152	BCEL814790Z	EL 4.7 $\mu$ F 50V
C153	BCXT813335Z	CC 0.033 $\mu$ F 50V K B Taping
C154	BCSC662286Z	TC 0.22 $\mu$ F 35V M C-182 Taping
C155	BCXT811525Z	CC 0.0015 $\mu$ F 50V K B Taping
C156	BCXT811525Z	CC 0.0015 $\mu$ F 50V K B Taping
C157	BCXT811035Z	CC 0.01 $\mu$ F 50V K B Taping
C158	BCEL814790Z	EL 4.7 $\mu$ F 50V
C159	BCXG815604Z	CC 56 PF 50V J CG Taping
C161	BCEL814790Z	EL 4.7 $\mu$ F 50V
C162	BCXT813335Z	CC 0.033 $\mu$ F 50V K B Taping
C163	BCXT813335Z	CC 0.033 $\mu$ F 50V K B Taping
C165	BCXT811525Z	CC 0.0015 $\mu$ F 50V K B Taping
C166	BCXT811525Z	CC 0.0015 $\mu$ F 50V K B Taping
C174	BCXT811525Z	CC 0.0015 $\mu$ F 50V K B Taping
C175	BCXT811525Z	CC 0.0015 $\mu$ F 50V K B Taping
C176	BCEL814790Z	EL 4.7 $\mu$ F 50V
C177	BCEL814790Z	EL 4.7 $\mu$ F 50V
C178	BCXS811045Z	CC 0.1 $\mu$ F 50V K B Taping
C179	BCXT811035Z	CC 0.01 $\mu$ F 50V K B Taping
C181	BCXS811045Z	CC 0.1 $\mu$ F 50V K B Taping
C201	BCXG811002Z	CC 10 PF 50V D CG
C202	BCXG811002Z	CC 10 PF 50V D CG
C301	BCXT811035Z	CC 0.01 $\mu$ F 50V K B Taping
C302	BCXT811035Z	CC 0.01 $\mu$ F 50V K B Taping
C303	BCXG817092Z	CC 7 PF 50V D CG Taping

Symbol	Part Number	Description
C304	BCXT811035Z	CC 0.01 $\mu$ F 50V K B Taping
C305	BCXT811035Z	CC 0.01 $\mu$ F 50V K B Taping
C306	BCXT811035Z	CC 0.01 $\mu$ F 50V K B Taping
C307	BCXT811035Z	CC 0.01 $\mu$ F 50V K B Taping
C401	BCXM814704Z	CC 47 PF 50V J RH Taping
C402	BCXG812214Z	CC 220 PF 50V J CG Taping
C403	BCXT811035Z	CC 0.01 $\mu$ F 50V K B Taping
C404	BCXT811035Z	CC 0.01 $\mu$ F 50V K B Taping
C405	BCXT811035Z	CC 0.01 $\mu$ F 50V K B Taping

### Diodes

D101	BDAY0381001	MA707 TX
D102	BDAY0381001	MA707 TX

### Connectors

J101	BJKY0449001	JK-449 C05-R104-02
J102	BJKY0449001	JK-449 C05-R104-02
J103	BJKY0491010	JK-491 10P
J201	BJKY0317002	JK-317 68907-102 2P
J202	BJKY0317002	JK-317 68907-102 2P
J301	BJKY0490002	JK-490 2P
J302	BJKY0490003	JK-490 3P
J401	BJKY0490003	JK-490 3P
J402	BJKY0490004	JK-490 4P

### Coils

L101	BLEY0244001	LE-244 D3.0 5 1/2T
L102	BLEY0052228	LZ-052 SP0305-R22K 0.22 $\mu$ H
L103	BLZY0052688	LZ-052 SP0305-R68K 0.68 $\mu$ H
L104	BLFY0152001	LF-152 5PNR-T1021Z
L105	BLZY0074102	LZ-074 1 MH
L106	BLZY0074102	LZ-074 1 MH
L107	BLZY0074102	LZ-074 1 MH
L201	BLFY0203001	LF-203
L202	BLFY0204001	LF-204
L301	BLZY0051229	LZ-051 SP0305-2R2M 2.2 $\mu$ H
L302	BLZY0067278	LZ-067 0.27 $\mu$ H Taping
L303	BLZY0067477	LZ-067 0.047 $\mu$ H Taping
L401	BLFY0193001	LF-193 341LNS-1356Z
L402	BLZY0051229	LZ-051 SP0305-2R2M 2.2 $\mu$ H

### Transistors

Q101	BDBC3357000	DB-754 2SC3357 T1
Q102	BDBC3357000	DB-754 2SC3357 T1
Q103	BDBZ0614001	DB-614 MRF581
Q301	BDBC3356644	DB-711 2SC3356-R22 T1B

### Resistors

R101	BRFC015624Z	RC 5.6K 1/10W J Taping
R102	BRFC011224Z	RC 1.2K 1/10W J Taping
R103	BRFC011814Z	RC 180 1/10W J Taping
R104	BRFC018214Z	RC 820 1/10W J Taping
R105	BRFC011014Z	RC 100 1/10W J Taping



Symbol	Part Number	Description
R106	BRFC011014Z	RC 100 1/10W J Taping
R107	BRFC013904Z	RC 39 1/10W J Taping
R109	BRFC013314Z	RC 330 1/10W J Taping
R111	BRFC011524Z	RC 1.5K 1/10W J Taping
R112	BRFC011014Z	RC100 1/10W J Taping
R113	BRFC015604Z	RC 56 1/10W J Taping
R117	BRFC011014Z	RC100 1/10W J Taping
R118	BRFC011004Z	RC10 1/10W J Taping
R119	BRFC011004Z	RC10 1/10W J Taping
R121	BRFC011024Z	RC1K 1/10W J Taping
R122	BRFC011034Z	RC10K 1/10W J Taping
R123	BRFC011004Z	RC10 1/10W J Taping
R124	BRFC014714Z	RC 470 1/10W J Taping
R125	BRFC014734Z	RC 47K 1/10W J Taping
R126	BRFC011044Z	RC 100K 1/10W J Taping
R129	BRFC015614Z	RC 560 1/10W J Taping
R131	BRFC015614Z	RC 560 1/10W J Taping
R132	BRFC014704Z	RC 47 1/10W J Taping
R133	BRFC013314Z	RC 330 1/10W J Taping
R301	BRFC012724Z	RC 2.7K 1/10W J Taping
R302	BRFC018224Z	RC 8.2K 1/10W J Taping
R303	BRFC011014Z	RC 100 1/10W J Taping
R304	BRFC015604Z	RC 56 1/10W J Taping
R305	BRFC011014Z	RC 100 1/10W J Taping

#### Filters

FT101	BFLY0297001	FL-297 DFC2R899P006BTD
FT102	BFLY0406001	FL-406 DFC5R902P025BTD
FT103	BFLY0408001	FL-408 59.9375 MHz
FT104	BFLY0405001	FL-405 DFC3R836P025BTD
FT105	BFLY0416001	FL-416 CFK455F4
FT106	BFLY0409001	FL-409 SFH455F
FT201	BFLY0407001	FL-407 59.9375 MHz

#### Integrated Circuits

IC101	BDEY1479001	SA604AD
IC102	BDEY1451001	NJM4560M
IC103	BDEY0401001	UPC7808H
IC401	BDEY1163001	SA602D

#### Miscellaneous

PC101	BPDY0438AAZ	RX Module (PD-438AA) Blank PCB
PC201	BPDY0458AAZ	Crystal Filter (PD-458AA) Blank PCB
PC301	BPDY0378AAZ	IF (PD-378AA) Blank PCB
PC401	BPDY0377AAZ	2ND Mixer (PD-377AA) Blank PCB
X101	BQXY0339001	Crystal QX-339 59.4825 MHz

## Local Oscillator Module (PD-439AA and PD-440AA)

### Capacitors

Symbol	Part Number	Description
C101	BCXG811204Z	CC 12 PF 50V J CG Taping
C102	BCXG811204Z	CC 12 PF 50V J CG Taping
C103	BCXG811204Z	CC 12 PF 50V J CG Taping
C104	BCXG811204Z	CC 12 PF 50V J CG Taping
C105	BCEL314700Z	EL 47 $\mu$ F 16V
C106	BCXS811045Z	CC 0.1 $\mu$ F 50V K B Taping
C107	BCXS811045Z	CC 0.1 $\mu$ F 50V K B Taping
C108	BCEL314700Z	EL 47 $\mu$ F 16V
C109	BCXS811045Z	CC 0.1 $\mu$ F 50V K B Taping
C110	BCXS811045Z	CC 0.1 $\mu$ F 50V K B Taping
C111	BCXS811045Z	CC 0.1 $\mu$ F 50V K B Taping
C112	BCEL314700Z	EL 47 $\mu$ F 16V
C113	BCXS811045Z	CC 0.1 $\mu$ F 50V K B Taping
C114	BCSE314796Z	TT 4.7 $\mu$ F 16V M
C115	BCXS811045Z	CC 0.1 $\mu$ F 50V K B Taping
C116	BCEL811000Z	EL 10 $\mu$ F 50V
C117	BCXS811045Z	CC 0.1 $\mu$ F 50V K B Taping
C118	BCSC661096Z	TC 1 $\mu$ F 35V M C-182 Taping
C119	BCXH811014Z	CC 100 PF 50V J SL Taping
C120	BCXG811204Z	CC 12 PF 50V J CG Taping
C121	BCXG811204Z	CC 12 PF 50V J CG Taping
C122	BCXT811025Z	CC 0.001 $\mu$ F 50V K B Taping
C123	BCXS814735Z	CC 0.047 $\mu$ F 50V K B Taping
C124	BCXT811025Z	CC 0.001 $\mu$ F 50V K B Taping
C125	BCXG811204Z	CC 12 PF 50V J CG Taping
C126	BCXG813304Z	CC 33 PF 50V J CG Taping
C127	BCXG812204Z	CC 22 PF 50V J CGTaping
C128	BCXT811025Z	CC 0.001 $\mu$ F 50V K B
C129	BCXS814735Z	CC 0.047 $\mu$ F 50V K B
C130	BCXT811025Z	CC 0.001 $\mu$ F 50V K B
C131	BCXG811204Z	CC 12 PF 50V J CG Taping
C132	BCXG811204Z	CC 12 PF 50V J CG Taping
C133	BCXS814735Z	CC 0.047 $\mu$ F 50V K B Taping
C134	BCXT811025Z	CC 0.001 $\mu$ F 50V K B Taping
C135	BCXG811204Z	CC 12 PF 50V J CG Taping
C136	BCSE111006Z	TT 10 $\mu$ F 10V M
C137	BCXS814735Z	CC 0.047 $\mu$ F 50V K B Taping
C138	BCXG811204Z	CC 12 PF 50V J CG Taping
C139	BCXG811204Z	CC 12 PF 50V J CG Taping
C140	BCXT811025Z	CC 0.001 $\mu$ F 50V K B Taping
C141	BCXS811045Z	CC 0.1 $\mu$ F 50V K B Taping
C142	BCXS811045Z	CC 0.1 $\mu$ F 50V K B Taping
C143	BCEL811000Z	EL 10 $\mu$ F 50V
C144	BCXG813304Z	CC 33 PF 50V J CG Taping
C145	BCXG812204Z	CC 22 PF 50V J CGTaping

Symbol	Part Number	Description
C146	BCSE661096Z	TT 1 $\mu$ F 35V M
C147	BCXT811025Z	CC 0.001 $\mu$ F 50V K B Taping
C148	BCXG811204Z	CC 12 PF 50V J CG Taping
C149	BCXT811025Z	CC 0.001 $\mu$ F 50V K B Taping
C150	BCXG814091Z	CC 4 PF 50V C CG Taping
C151	BCXG811204Z	CC 12 PF 50V J CG Taping
C152	BCSE661096Z	TT 1 $\mu$ F 35V M
C153	BCSE114706Z	TT 47 $\mu$ F 16V M
C154	BCXG811204Z	CC 12 PF 50V J CG Taping
C155	BCXG811204Z	CC 12 PF 50V J CG Taping
C156	BCXG811204Z	CC 12 PF 50V J CG Taping
C157	BCEL111010Z	EL 100 $\mu$ F 10V
C158	BCXH811014Z	CC 100 PF 50V J SL Taping
C159	BCXG811204Z	CC 12 PF 50V J CG Taping
C160	BCXG814091Z	CC 4 PF 50V C CG Taping
C161	BCXS814735Z	CC 0.047 $\mu$ F 50V K B Taping
C162	BCSC311096Z	TC 1 $\mu$ F 16V M C-182
C163	BCXH811014Z	CC 100 PF 50V J SL Taping
C164	BCXH811014Z	CC 100 PF 50V J SL Taping
C165	BCEL811000Z	EL 10 $\mu$ F 50V
C166	BCEL811000Z	EL 10 $\mu$ F 50V
C167	BCXG811204Z	CC 12 PF 50V J CG Taping
C168	BCXG813304Z	CC 33 PF 50V J CG Taping
C169	BCXG813304Z	CC 33 PF 50V J CG Taping
C171	BCXG811204Z	CC 12 PF 50V J CG Taping
C172	BCXG811204Z	CC 12 PF 50V J CG Taping
C173	BCSC311096Z	TC 1 $\mu$ F 16V M C-182
C174	BCXG811204Z	CC 12 PF 50V J CG Taping
C175	BCXG811204Z	CC 12 PF 50V J CG Taping
C176	BCXG811204Z	CC 12 PF 50V J CG Taping
C177	BCXG811204Z	CC 12 PF 50V J CG Taping
C178	BCXG811204Z	CC 12 PF 50V J CG Taping
C179	BCXG811204Z	CC 12 PF 50V J CG Taping
C180	BCXG811204Z	CC 12 PF 50V J CG Taping
C181	BCXG811204Z	CC 12 PF 50V J CG Taping
C182	BCXT811035Z	CC 0.01 $\mu$ F 50V K B
C183	BCXG811204Z	CC 12 PF 50V J CG Taping
C184	BCXG811204Z	CC 12 PF 50V J CG Taping
C185	BCXG811204Z	CC 12 PF 50V J CG Taping
C186	BCXG811204Z	CC 12 PF 50V J CG Taping
C187	BCXG811204Z	CC 12 PF 50V J CG Taping
C188	BCXG813304Z	CC 33 PF 50V J CG Taping
C189	BCXG811204Z	CC 12 PF 50V J CG Taping
C191	BCEL314700Z	EL 47 $\mu$ F 16V
C192	BCEL314700Z	EL 47 $\mu$ F 16V
C193	BDSE112206Z	TT 22 $\mu$ F 10V M
C194	BCXT811025Z	CC 0.001 $\mu$ F 50V K B Taping
C195	BCXT811025Z	CC 0.001 $\mu$ F 50V K B Taping
C196	BCXG813304Z	CC 33 PF 50V J CG Taping
C201	BCXT811025Z	CC 0.001 $\mu$ F 50V K B Taping

Symbol	Part Number	Description
C202	BCXH813304Z	CC 33 PF 50V J SL Taping
C203	BCXH813304Z	CC 33 PF 50V J SL Taping
C204	BCXH813304Z	CC 33 PF 50V J SL Taping
C205	BCXH811014Z	CC 100 PF 50V J SL Taping
C206	BCXS811045Z	CC 0.1 $\mu$ F 50V K B Taping
C207	BCXT811025Z	CC 0.001 $\mu$ F 50V K B Taping
C208	BCXT812235Z	CC 0.022 $\mu$ F 50V K B Taping
C209	BCXT811025Z	CC 0.001 $\mu$ F 50V K B Taping
C210	BCXS811045Z	CC 0.1 $\mu$ F 50V K B Taping
C211	BCXT811025Z	CC 0.001 $\mu$ F 50V K B Taping
C212	BCXG813091Z	CC 3 PF 50V C CG (CH) Taping
C213	BCXG811002Z	CC 10 PF 50V D CG Taping
C214	BCXH811014Z	CC 100 PF 50V J SL Taping
C215	BCAT114706Z	EL 47 $\mu$ F 10V M C-136
C216	BCXS811045Z	CC 0.1 $\mu$ F 50V K B Taping
C217	BCAT114706Z	EL 47 $\mu$ F 10V M C-136
C218	BCST112206Z	TC 22 $\mu$ F 10V M C C-222 Taping
C219	BCSC114796Z	TC 4.7 $\mu$ F 10V M C-182 Taping
C220	BCXT811035Z	CC 0.01 $\mu$ F 50V K B Taping
C221	BCSC663385Z	TC 0.33 $\mu$ F 35V K C-182 Taping
C222	BCSC114795Z	TC 4.7 $\mu$ F 10V K C-182 Taping
C223	BCSC661085Z	TC 0.1 $\mu$ F 35V K C-182 Taping
C224	BCXT811035Z	CC 0.01 $\mu$ F 50V K B Taping
C225	BCXG813091Z	CC 3 PF 50V C CG (CH) Taping

### Diodes

D101	BDAY0339001	DLS1585 TPH11
D102	BDAY0574001	MI808-T11
D201	BDAY0339001	DLS1585 TPH11

### Connectors

J101	BJKY0491015	JK-491 15P
J102	BJKY0449001	JK-449 C05-R104-02
J103	BJKY0449001	JK-449 C05-R104-02
J201	BJKY0492009	JK-492 9P
J202	BJKY0492002	JK-492 2P

### Coils

L101	BLDY0077001	LD-077 BF03-1.8*5*0.7
L102	BLDY0077001	LD-077 BF03-1.8*5*0.7
L103	BLDY0077001	LD-077 BF03-1.8*5*0.7
L104	BLDY0077001	LD-077 BF03-1.8*5*0.7
L105	BLDY0077001	LD-077 BF03-1.8*5*0.7
L106	BLZY0067478	LZ-067 0.47U TAPE
L107	BLZY0051101	LZ-051 SP0305-101K 100 $\mu$ H
L108	BLZY0067478	LZ-067 0.47U TAPE
L110	BLDY0077001	LD-077 BF03-1.8*5*0.7
L111	BLDY0077001	LD-077 BF03-1.8*5*0.7

Symbol	Part Number	Description
L112	BLDY0077001	LD-077 BF03-1.8*5*0.7
L113	BLDY0077001	LD-077 BF03-1.8*5*0.7
L114	BLZY0051101	LZ-051 SP0305-101K 100 $\mu$ H
L115	BLDY0077001	LD-077 BF03-1.8*5*0.7
L116	BLZY0067687	LZ-067 0.068 $\mu$ H Taping
L117	BLZY0067687	LZ-067 0.068 $\mu$ H Taping

### Transistors

Q101	BDBB1121119	DB-137 2SB1121-T Taping
Q102	BDBD1048661	DB-435 2SD1048-X6 Taping
Q103	BDBC2412547	DB-396 2SC2412K-R T96
Q104	BDBC2412547	DB-396 2SC2412K-R T96
Q201	BDBC2412547	DB-396 2SC2412K-R T96

### Resistors

R101	BRFC012214Z	RC 220 1/10W J Taping
R102	BRFC011034Z	RC 10K 1/10W J Taping
R103	BRFC011034Z	RC 10K 1/10W J Taping
R104	BRFC011034Z	RC 10K 1/10W J Taping
R105	BRFC011814Z	RC 180 1/10W J Taping
R106	BRFC013314Z	RC 330 1/10W J Taping
R107	BRFC013314Z	RC 330 1/10W J Taping
R108	BRFC011804Z	RC 18 1/10W J Taping
R109	BRFC013314Z	RC 330 1/10W J Taping
R110	BRFC011014Z	RC 100 1/10W J Taping
R111	BRFC011804Z	RC 18 1/10W J Taping
R112	BRFC013314Z	RC 330 1/10W J Taping
R113	BRFC011024Z	RC 1K 1/10W J Taping
R114	BRFC011804Z	RC 18 1/10W J Taping
R115	BRFC011024Z	RC 1K 1/10W J Taping
R116	BRFC011034Z	RC 10K 1/10W J Taping
R117	BRFC011814Z	RC 180 1W J
R118	BRFC011004Z	RC 10 1/10W J Taping
R119	BRFC011214Z	RC 120 1/10W J Taping
R121	BRFC015104Z	RC 51 1/10W J Taping
R122	BRFC011214Z	RC 120 1/10W J Taping
R123	BRFC011814Z	RC 180 1/10W J Taping
R124	BRFC013304Z	RC 33 1/10W J Taping
R125	BRFC011814Z	RC 180 1/10W J Taping
R126	BRFC012224Z	RC 2.2K 1/10W J Taping
R127	BRFC012224Z	RC 2.2K 1/10W J Taping
R128	BRFC012234Z	RC 22K 1/10W J Taping
R129	BRFC014734Z	RC 47K 1/10W J Taping
R130	BRFC012734Z	RC 27K 1/10W J Taping
R131	BRFC018214Z	RC 820 1/10W J Taping
R132	BRFC011534Z	RC 15K 1/10W J Taping
R133	BRFC012734Z	RC 27K 1/10W J Taping
R134	BRFC012224Z	RC 2.2K 1/10W J Taping
R135	BRFC011537Z	RC 15K 1/10W G Taping
R136	BRFC011837Z	RC 18K 1/10W G Taping

Symbol	Part Number	Description
R137	BRFC012234Z	RC 22K 1/10W J Taping
R138	BRFC011034Z	RC 10K 1/10W J Taping
R139	BRFC015614Z	RC 560 1/10W J Taping
R140	BRFC011044Z	RC 100K 1/10W J Taping
R141	BRFC011044Z	RC 100K 1/10W J Taping
R142	BRFC013324Z	RC 3.3K 1/10W J Taping
R143	BRFC015104Z	RC 51 1/10W J Taping
R191	BRFC016814Z	RC 680 1/10W J Taping
R201	BRFC011034Z	RC 10K 1/10W J Taping
R202	BRFC011044Z	RC 100K 1/10W J Taping
R203	BRFC011204Z	RC 12 1/10W J Taping
R204	BRFC011014Z	RC 100 1/10W J Taping
R205	BRFC017504Z	RC 75 1/10W J Taping
R206	BRFC011014Z	RC 100 1/10W J Taping
R207	BRFC016814Z	RC 680 1/10W J Taping
R208	BRFC011527Z	RC 1.5K 1/10W G Taping
R209	BRFC015627Z	RC 5.6K 1/10W G Taping
R210	BRFC014724Z	RC 4.7K 1/10W J Taping
R211	BRFC011004Z	RC 10 1/10W J Taping
R212	BRFC011804Z	RC 18 1/10W J Taping

### Integrated Circuits

IC101	BDEY0767001	UPC78M05H
IC102	BDEY0827001	UPC78L08J
IC103	BDEY0768001	UPC78L05J
IC104	BDEY0773001	UPC317H
IC105	BDEY1653001	UPC1678G
IC106	BDEY1444001	TC40107BP
IC108	BDEY0827001	UPC78L08J
IC109	BDEY1653001	UPC1678G
IC111	BDEY1652001	M57781
IC112	BDEY0145001	NJM4558D
IC113	BDEY0145001	NJM4558D
IC114	BDEY0145001	NJM4558D
IC115	BDEY1246001	THB127B
IC201	BDEY1443001	MB1501PF
IC202	BDEY1651001	VCO UC1295
IC203	BDEY1190001	UPC1675G-T1

### Variable Resistors

VR101	BRTY0507102	RT-507 1KB
VR103	BRTY0507103	RT-507 10KB
VR104	BRTY0507103	RT-507 10KB
VR105	BRTY0507223	RT-507 22KB

### Miscellaneous

W101	BWZY0838001	Coaxial Cable WZ-838
Y101	BYYY0906001	PLL Module (TX) YY-906
PC101	BPDY0439AAZ	Local Oscillator (PD-439AA) Blank PCB
PC201	BPDY0440AAZ	RX PLL (PD-440AA) Blank PCB

## ARX 800A Logic Controller Board

			<b>Capacitors</b>
<b>Symbol</b>	<b>Part Number</b>	<b>Description</b>	
C1	BCCC812204Z	CD 22PF 50V DD014 CH220 J-50	
C2	BCCC812204Z	CD 22PF 50V DD014 CH220 J-50	
C3	BCKC811040Z	CD 0.1 $\mu$ F 16V DD 307F 104Z16	
C4	BCKC811040Z	CD 0.1 $\mu$ F 16V DD 307F 104Z16	
C5	BCKC811040Z	CD 0.1 $\mu$ F 16V DD 307F 104Z16	
C6	BCKC811040Z	CD 0.1 $\mu$ F 16V DD 307F 104Z16	
C7	BCQM811024Z	MF 0.001 $\mu$ F 50V AMZ 102J	
C8	BCSE511096Z	TT 1 $\mu$ F 25V DNIE 010 MIS	
C9	BCSE511096Z	TT 1 $\mu$ F 25V DNIE 010 MIS	
C10	BCQM812224Z	MF 0.0022 $\mu$ F 50V AMZ 222J	
C11	BCSE511096Z	TT 1 $\mu$ F 25V DNIE 010 MIS	
C14	BCER511006Z	EL 10 $\mu$ F 25V SME 25 VB-10	
C15	BCER511006Z	EL 10 $\mu$ F 25V SME 25 VB-10	
C16	BCER811040Z	EL 4.7 $\mu$ F 50V SME 50 VB-4.7	
C17	BCQM811234Z	MF 0.012 $\mu$ F 50V AMZ 123J	
C18	BCQM811034Z	MF 0.01 $\mu$ F 50V AMZ 103J	
C19	BCQM812745Z	MF 0.27 $\mu$ F 50V AMZ 273J	
C20	BCQM811234Z	MF 0.012 $\mu$ F 50V AMZ 123J	
C21	BCER511016Z	EL 100 $\mu$ F 25V SME 25 VB-10	
C23	BCKC512240Z	CD 0.2 $\mu$ F 16V DD 307F 104Z16	
C24	BCSB312206Z	TT 22 $\mu$ F 16V DNIC 220M IS	
C25	BCKC811040Z	CD 0.1 $\mu$ F 16V DD 307F 104Z16	
C26	BCQM813334Z	MF 0.033 $\mu$ F 50V AMZ 333J	
C27	BCSE514786Z	TT 0.47 $\mu$ F 20V DSB1D 474 M 1M	
C28	BCKC811040Z	CD 0.1 $\mu$ F 16V DD 307F 104Z16	
C29	BCER811096Z	EL 1 $\mu$ F 50V SME 50VB-1	
C30	BCQM811524Z	MF 0.0015 $\mu$ F 50V AMZ 152J	
C31	BCER811096Z	EL 1 $\mu$ F 50V SME 50VB-1	
C32	BCQM814724Z	MF 0.0047 $\mu$ F 50V AMZ 412J	
C33	BCQM814724Z	MF 0.0047 $\mu$ F 50V AMZ 412J	
C34	BCER811096Z	EL 1 $\mu$ F 50V SME 50VB-1	
C35	BCER511016Z	EL 100 $\mu$ F 25V SME 25 VB-10	
C36	BCER511006Z	EL 10 $\mu$ F 25V SME 25 VB-10	
C37	BCER511006Z	EL 10 $\mu$ F 25V SME 25 VB-10	
C38	BCER511006Z	EL 10 $\mu$ F 25V SME 25 VB-10	
C39	BCER511006Z	EL 10 $\mu$ F 25V SME 25 VB-10	
C40	BCER511006Z	EL 10 $\mu$ F 25V SME 25 VB-10	
C41	BCER511006Z	EL 10 $\mu$ F 25V SME 25 VB-10	
C42	BCER511006Z	EL 10 $\mu$ F 25V SME 25 VB-10	
C43	BCER511006Z	EL 10 $\mu$ F 25V SME 25 VB-10	
C44	BCKC811040Z	CD 0.1 $\mu$ F 16V DD 307F 104Z16	
C45	BCKC811040Z	CD 0.1 $\mu$ F 16V DD 307F 104Z16	
C46	BCKC811040Z	CD 0.1 $\mu$ F 16V DD 307F 104Z16	
C47	BCKC811040Z	CD 0.1 $\mu$ F 16V DD 307F 104Z16	
C48	BCKC811040Z	CD 0.1 $\mu$ F 16V DD 307F 104Z16	

Symbol	Part Number	Description
C49	BCKC811040Z	CD 0.1μF 16V DD 307F 104Z16
C50	BCKC811040Z	CD 0.1μF 16V DD 307F 104Z16
C51	BCKC811040Z	CD 0.1μF 16V DD 307F 104Z16
C52	BCKC811040Z	CD 0.1μF 16V DD 307F 104Z16
C53	BCKC811040Z	CD 0.1μF 16V DD 307F 104Z16
C54	BCKC811040Z	CD 0.1μF 16V DD 307F 104Z16
C55	BCKC811040Z	CD 0.1μF 16V DD 307F 104Z16
C56	BCKC811040Z	CD 0.1μF 16V DD 307F 104Z16
C57	BCKC811040Z	CD 0.1μF 16V DD 307F 104Z16
C58	BCKC811040Z	CD 0.1μF 16V DD 307F 104Z16
C59	BCKC811040Z	CD 0.1μF 16V DD 307F 104Z16
C60	BCKC811040Z	CD 0.1μF 16V DD 307F 104Z16
C61	BCKC811040Z	CD 0.1μF 16V DD 307F 104Z16
C62	BCKC811040Z	CD 0.1μF 16V DD 307F 104Z16
C63	BCQM814734Z	MF 0.047μF 50V AMZ 473J
C66	BCKC814730Z	CD 0.047μF50V Z ZF
C70	BCCC814714Z	CD 470PF 50V DD104B 471K

### Diodes

D1	BDAY0131001	1S2076
D2	BDAY0131001	1S2076
D3	BDAY0131001	1S2076
D4	BDAY0131001	1S2076
D5	BDAY0131001	1S2076
D6	BDAY0131001	1S2076
D7	BDAY0131001	1S2076
D8	BDAY0131001	1S2076
D9	BDAY0131001	1S2076
D10	BDAY0131001	1S2076
D11	BDAY0131001	1S2076
D12	BDAY0131001	1S2076
D13	BDAY0131001	1S2076
D14	BDAY0131001	1S2076
D15	BDAY0131001	1S2076
D16	BDAY0131001	1S2076
D17	BDAY0131001	1S2076
D18	BDAY0131001	1S2076
D19	BDAY0131001	1S2076
D20	BDAY0131001	1S2076
D21	BDAY0131001	1S2076
D22	BDAY0131001	1S2076
D23	BDAY0131001	1S2076
D24	BDAY0131001	1S2076
D25	BDAY0131001	1S2076
D26	BDAY0131001	1S2076
D27	BDAY0131001	1S2076
D28	BDAY0131001	1S2076
D29	BDAY0131001	1S2076
D30	BDAY0131001	1S2076



Symbol	Part Number	Description
D31	BDAY0131001	1S2076
D32	BDAY0131001	1S2076
D33	BDAY0131001	1S2076
D34	BDAY0131001	1S2076
D35	BDAY0131001	1S2076
D36	BDAY0131001	1S2076
D37	BDAY0131001	1S2076
D38	BDAY0131001	1S2076
D39	BDAY0131001	1S2076
D40	BDAY0131001	1S2076
D41	BDAY0131001	1S2076
D42	BDAY0131001	1S2076

### Integrated Circuits

IC1	N.A.	HD64B180ROP (CPU)
IC2	BDEY0950001	M5L27356K (ROM-250ns)
IC3	BDEY0779001	HM6264LP-15 (RAM -150ns)
IC4	BDEY0473001	M5L8255AP-5 (PIO)
IC5	N.A.	HD74HC240P
IC6	BDEY6079001	HD74HC138P
IC7	BDEY6078001	HD74HC32P
IC8	BDEY0272001	HD74HC04FP
IC9	BDEY0912001	HD14538BP
IC10	BDEY0898001	M51953B
IC12	N.A.	SN75238N
IC13	BDEY0973001	HD74HC74FP
IC15	BDEY0774001	HD14020BP
IC16	BDEY0973001	HD74HC74FP
IC17	BDEY0799001	UC-1102
IC18	BDEY0882001	UC-1119
IC19	BDEY0802001	UC-1105
IC20	BDEY0411001	HD14066BP
IC21	BDEY0560001	M5218P
IC22	BDEY0560001	M5218P
IC23	BDEY0560001	M5218P
IC24	BDEY0560001	M5218P
IC25	BDEY0560001	M5218P
IC26	BDEY0709001	M5278L08P
IC27	BDEY0586001	M5F7805P

### Coils

L1	N.A.	SN-5-400 Choke Coil 48 $\mu$ H
L2	N.A.	LAL03NA471K 470 $\mu$ H

### Transistors

Q1	N.A.	DTC124ES
Q2	N.A.	DTC124ES
Q3	N.A.	DTC124ES
Q4	N.A.	DTC124ES
Q5	N.A.	DTC124ES
Q6	N.A.	DTC124ES
Q7	N.A.	DTC124ES

Symbol	Part Number	Description
Q8	N.A.	DTC124ES
Q9	N.A.	DTC124ES
Q10	N.A.	DTC124ES
Q11	N.A.	DTC124ES
Q12	N.A.	DTC124ES

### Resistors

R1	BRUB141044Z	CF 100K 1/4W J
R2	BRUB141044Z	CF 100K 1/4W J
R3	BRUB141544Z	CF 150K 1/4W J
R4	BRUB141044Z	CF 100K 1/4W J
R5	BRUB141034Z	CF 10K 1/4W J
R6	BRUB144734Z	CF 47K 1/4W J
R7	BRUB141014Z	CF 100 1/4W J
R8	BRUB141014Z	CF 100 1/4W J
R9	BRUB144734Z	CF 47K 1/4W J
R10	BRUB144734Z	CF 47K 1/4W J
R11	BRUB142234Z	CF 22K 1/4W J
R12	BRUB141044Z	CF 100K 1/4W J
R13	BRUB148224Z	CF 8.2K 1/4W J
R14	BRUB141034Z	CF 10K 1/4W J
R15	BRUB142744Z	CF 270K 1/4W J
R16	BRUB143344Z	CF 330K 1/4W J
R17	BRUB148234Z	CF 82K 1/4W J
R18	BRUB148234Z	CF 82K 1/4W J
R19	BRUB148234Z	CF 82K 1/4W J
R20	BRUB148234Z	CF 82K 1/4W J
R21	BRUB142044Z	CF 200K 1/4W J
R23	BRUB141044Z	CF 100K 1/4W J
R24	BRUB144724Z	CF 4.7K 1/4W J
R25	BRUB144724Z	CF 4.7K 1/4W J
R26	BRUB142244Z	CF 220K 1/4W J
R27	BRUB143324Z	CF 3.3K 1/4W J
R28	BRUB146824Z	CF 6.8K 1/4W J
R29	BRUB141034Z	CF 10K 1/4W J
R30	BRUB142734Z	CF 27K 1/4W J
R31	BRUB145634Z	CF 56K 1/4W J
R32	BRUB143934Z	CF 39K 1/4W J
R33	BRUB143934Z	CF 39K 1/4W J
R34	BRUB141034Z	CF 10K 1/4W J
R35	BRUB141034Z	CF 10K 1/4W J
R36	BRUB141034Z	CF 10K 1/4W J
R37	BRUB143334Z	CF 33K 1/4W J
R38	BRUB141044Z	CF 100K 1/4W J
R39	BRUB141034Z	CF 10K 1/4W J
R40	BRUB141044Z	CF 100K 1/4W J
R41	BRUB143014Z	CF 300 1/4W J
R42	BRUB143014Z	CF 300 1/4W J
R43	BRUB141034Z	CF 10K 1/4W J
R44	BRUB143934Z	CF 39K 1/4W J
R45	BRUB141034Z	CF 10K 1/4W J
R46	BRUB143934Z	CF 39K 1/4W J

Symbol	Part Number	Description
R47	BRUB141034Z	CF 10K 1/4W J
R48	BRUB141034Z	CF 10K 1/4W J
R49	BRUB141034Z	CF 10K 1/4W J
R50	BRUB141034Z	CF 10K 1/4W J
R51	BRUB141034Z	CF 10K 1/4W J
R52	BRUB144734Z	CF 47K 1/4W J
R53	BRUB144734Z	CF 47K 1/4W J
R54	BRUB144734Z	CF 47K 1/4W J
R56	BRUB144734Z	CF 47K 1/4W J
R58	BRUB145614Z	CF 560 1/4W J
R59	BRUB145614Z	CF 560 1/4W J
R60	BRUB142714Z	CF 270 1/4W J
R61	BRUB144734Z	CF 47K 1/4W J
R62	BRUB144734Z	CF 47K 1/4W J
R63	BRUB141024Z	CF 1K 1/4W J
R64	BRUB145634Z	CF 56K 1/4W J
R65	BRUB141034Z	CF 10K 1/4W J
R66	BRUB143934Z	CF 39K 1/4W J
R68	BRUB141244Z	CF 120K 1/4W J
R69	BRUB144734Z	CF 47K 1/4W J
R70	BRUB142234Z	CF 22K 1/4W J
R71	BRUB144734Z	CF 47K 1/4W J

### Resistor Arrays

RR1	N.A.	RR 47K 1/8W C09X J (X8)
RR2	N.A.	RR 47K 1/8W C09X J (X8)
RR3	N.A.	RR 47K 1/8W C09X J (X8)
RR4	N.A.	RR 47K 1/8W C05X J (X8)
RR5	N.A.	RR 10K 1/8W C09X J (X8)
RR6	N.A.	RR 47K 1/8W C09X J (X8)
RR7	N.A.	RR 47K 1/8W C05X J (X8)

### Variable Resistors

VR1	BRTY0528474	RT 470K 1/4W RH0651CS J
VR2	BRTY0528103	RT 10K 1/4W RH0651CS J
VR3	BRTY0528103	RT 10K 1/4W RH0651CS J
VR4	BRTY0528223	RT 22K 1/4W RH0651CS J
VR5	BRTY0528473	RT 47K 1/4W RH0651CS J
VR6	BRTY0528104	RT 100K 1/4W RH0651CS J

### Switches

S1	BSWY0388001	SSGM48002A
S2	BSWY0388001	SSGM48002A
S3	BSWY0388001	SSGM48002A
S4	BSWY0388001	SSGM48002A
S5	BSWY0388001	SSGM48002A

### Miscellaneous

N1	N.A.	3094-13A
CN2	N.A.	3094-13A
CN3	N.A.	PS-50PE-D4TI-PN1
SK1	BSKY0047064	DICS-64CS (64-pin IC socket)
SK2	BSKY0041028	DICF-28AS-E (28-pin IC socket)

Symbol	Part Number	Description
TH1	BFDY0014002	TD5-C310D2H thermistor
TP1	N.A.	ST-4-2
TP2	N.A.	ST-4-2
TP3	N.A.	ST-4-2
TP4	N.A.	ST-4-2
TP5	N.A.	ST-4-2
TP6	N.A.	ST-4-2
TP7	N.A.	ST-4-2
TP8	N.A.	ST-4-2
TP9	N.A.	ST-4-2
TP10	N.A.	ST-4-2
X1	BQXY0180001	Crystal 12.150 MHz

# INSTALLING THE ARX 2940 SINGLE HIGH STABILITY OSCILLATOR

**ADJUSTMENT OF THE ARX 2940 WITHOUT THE PROPER EQUIPMENT MAY CAUSE AN INCORRECT FREQUENCY SETTING. THIS IS DUE TO THE EXTREMELY TIGHT FREQUENCY TOLERANCE THAT THE FCC HAS PLACED ON 900 MHZ SYSTEMS.**

**THE ADJUSTMENT SCREW IS FACTORY SEALED. THE WARRANTY OF THIS UNIT WILL VOID IF THE SEAL IS BROKEN. THE WARRANTY OF THIS UNIT MAY BECOME VOID IF THE UNIT IS MISHANDLED. CONTACT UNIDEN SUPPORT SERVICES BEFORE ATTEMPTING ANY ADJUSTMENT.**

The ARX 2940 is a single high-stability oscillator that supplies the frequency reference for one MRS 904. Unlike the ARX 2950, the ARX 2940 is not fully redundant. The ARX 2940 mounts inside of an MRS 904 repeater and obtains its power from the MRS 904. If your installation has four or more channels or if you plan to expand to four or more channels, Uniden recommends that you use an ARX 2950 Master Oscillator instead of the ARX 2940.

1. Place the MRS 904 unit on a flat static-free work surface.
2. Remove the eight screws that secure the top cover. There are two on each side, two on the top, and two on the rear.
3. Insert the 4" red/white wire into one of the +13.8VDC power holes at JU2 in the Relay Board and carefully solder it into place. See Figure 17.
4. Insert the 4" black/white wire into to one of the ground holes at JU2 in the DC Relay Assembly and carefully solder it into place. Check both solder connections and make sure that neither connection is shorted to ground.
5. Loosen the two captive slotted screws on the hinged chassis assembly that holds the receiver and transmitter modules. You can now lift the hinged chassis to a vertical position. This allows access to the Motherboard.
6. Plug the SMB connector into the reference SMB socket on the Motherboard.
7. Tighten the two captive slotted screws on the hinged chassis assembly.
8. Turn the MRS-904 over and remove the eight screws on the bottom panel.
9. The ARX 2940 mounts in front of the Relay Board. Locate the two pre-drilled holes under the bottom panel.
10. Insert the #4-40x1/4" screws through the pre-drilled holes and screw them into the threaded holes on the ARX 2940 mounting bracket.
11. Replace the bottom panel and and the top cover.

After you install the ARX 2940 in the MRS 904, allow the MRS 904 to warm up for 24 hours before you operate it.

## Parts List

Part Number	Description	Quantity
FZ027	Cable Harness Assembly	1
BDEY1720001	6.4 MHz Ovenized Oscillator	1
HHDZ250086Z	Mounting Bracket	1
JDPA450087Z	Warning Label	1
11001734	#4-40x1/4" Pan Head Screw	2

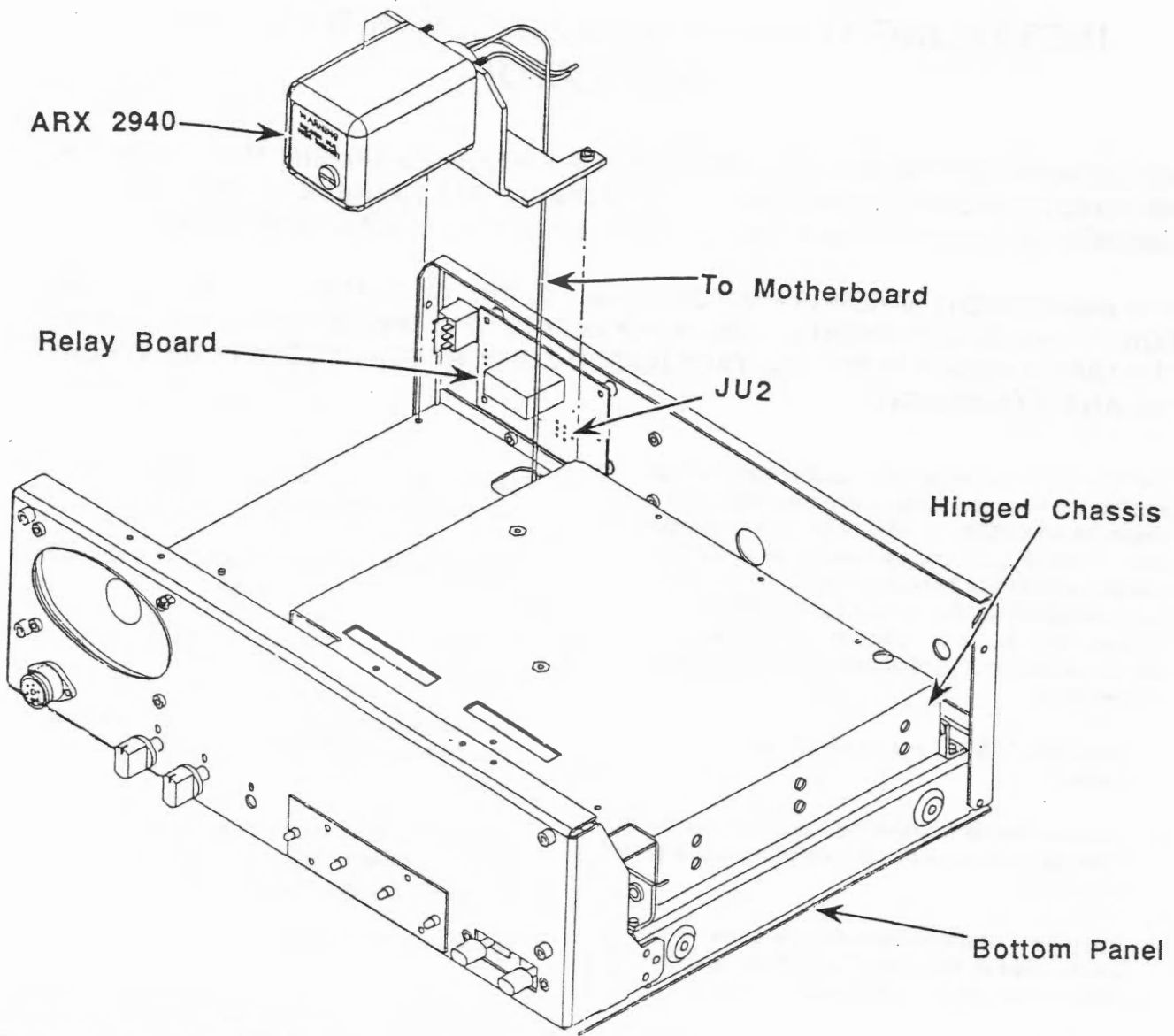

Figure 17. Installing the ARX 2940

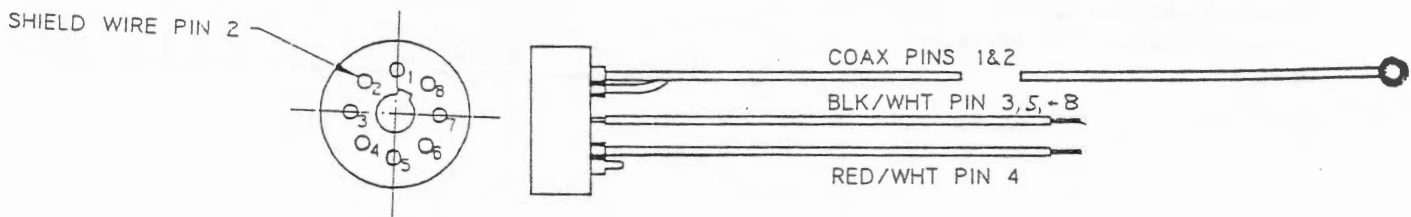

Figure 18. ARX 2940 Harness Assembly

1/1/90

# UNIDEN AMERICA CORPORATION COMMERCIAL COMMUNICATIONS TWO YEAR LIMITED WARRANTY

**WARRANTOR:** Uniden America Corporation ("Uniden" or "Warrantor")

**ELEMENTS OF WARRANTY:** Uniden warrants to the purchaser that all new Commercial Radio equipment of Uniden's manufacture (the Product) shall be free of defects in material and workmanship. Equipment and accessory items not manufactured by Uniden carry the warranty, if any, of the manufacturer thereof.

**WARRANTY DURATION:** The warranty period shall commence upon installation of the equipment or two (2) months from date of shipment from the factory, whichever occurs first. This Warranty shall terminate and be of no further effect two (2) years from commencement of the warranty period or at the time the Product is (a) damaged or not maintained as reasonable; (b) modified; (c) improperly installed; (d) is repaired by someone other than Warrantor or Authorized Warranty Repair Station for a defect or malfunction covered by this warranty; or (e) used in a manner or purpose for which the Product was not intended or in an environmental condition for which the Product was not intended.

**STATEMENT OF REMEDY:** In the event that the Product does not conform to this Warranty at any time while this Warranty is in effect, Warrantor will repair the defect and return the Product without charge for parts, service or any other cost incurred by Warrantor or its representatives in connection with the performance of this Warranty. **This Warranty does not cover or provide for reimbursement of payment of incidental or consequential damages. Any and all implied warranties, including, but not limited to, warranties of merchantability and/or fitness for any particular use, are expressly disclaimed.** Some states do not allow the exclusion or limitation of incidental or consequential damages so such limitation or exclusion may not apply to you.

**WARRANTY REGISTRATION CARD:** In order to facilitate the service under this Warranty, the Customer should return the Warranty Registration Card to Warrantor. However, return of the Warranty Registration Card is not a precondition of this Warranty. This Warranty will be observed by Warrantor whether or not the Warranty Registration Card is returned, on the condition that other evidence, satisfactory to Uniden, of the date of the original installation or purchase is provided.

**PROCEDURE FOR OBTAINING PERFORMANCE OF WARRANTY:** To obtain warranty repair, the Customer must return the Product properly packed, freight prepaid, to Warrantor or any Authorized Warranty Repair Station. It will be returned freight prepaid.

UNITED STATES GOVERNMENT  
COMMERICAL BUREAU  
TWO YEAR COURSE IN FINANCE