



Rack Mount Repeater

VXR-9000 (UHF)

Service Manual

Vertex Standard LMR, Inc.

©2015 Vertex Standard LMR, Inc.
EC044U900

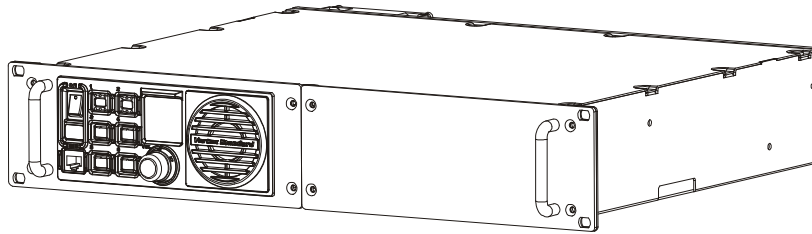

Introduction

This manual provides the technical information necessary for servicing the **VXR-9000** Rack Mount Repeater.

Servicing this equipment requires expertise in handling surface-mount chip components. Attempts by non-qualified persons to service this equipment may result in permanent damage not covered by the warranty, and may be illegal in some countries.

Two PCB layout diagrams are provided for each double-sided board in this transceiver. Each side of the board is referred to by the type of the majority of components installed on that side ("Side A" or "Side B"). In most cases one side has only chip components (surface-mount devices), and the other has either a mixture of both chip and leaded components (trimmers, coils, electrolytic capacitors, ICs, etc.), or leaded components only.

As described in the pages to follow, the advanced microprocessor design of the **VXR-9000** allows a complete alignment of this transceiver to be performed without opening the case of the radio; all adjustments can be performed from the personal computer, using with the Vertex Standard FIF-10A (or FIF-12) + CT-104A USB Programming Interface and CE60 Software.

While we believe the information in this manual to be correct, Vertex Standard assumes no liability for damage that may occur as a result of typographical or other errors that may be present. Your cooperation in pointing out any inconsistencies in the technical information would be appreciated.

Important Note

After Lot. 30 of this transceiver was assembled using Pb (lead) free solder, based on the RoHS specification.

Only lead-free solder (Alloy Composition: Sn-3.0Ag-0.5Cu) should be used for repairs performed on this apparatus. The solder stated above utilizes the alloy composition required for compliance with the lead-free specification, and any solder with the above alloy composition may be used.

Contents

Specifications	A-1	Board Units (Schematics, Layouts & Parts)	
DSUB 25-pin Accessory Connector	B-1	MAIN Unit	H-1
Exploded View & Miscellaneous Parts	C-1	CNTL Unit	I-1
Block Diagram	D-1	PANEL Unit	J-1
Connection Diagram	E-1	PA Unit	K-1
Circuit Description	F-1	PA-2 Unit	L-1
Alignment	G-1	REG Unit	M-1
		SUB Unit	N-1
		100 W PA Unit (Option: Version D)	O-1
		RELAY Unit (Option)	P-1

Specifications

General

Frequency Range:	A : 400 - 430 MHz, D : 450 - 490 MHz
Number of channel:	32
Channel Spacing:	12.5 kHz/25 kHz* * 25 kHz will not be available on new equipment in the U.S.A after 1/1/2013
Operating Voltage:	13.6 V DC \pm 10 %
Current Drain:	12 A Maximum
Duty Cycle:	100 % (@25 W output)
Frequency Stability:	1.5 ppm 1.0 ppm (30min after wake up)
Operating Temperature Range:	-22 °F to +140 °F (-30 °C to +60 °C)
Dimensions (W x H x D):	19 x 3-1/2 x 13-1/2 inch (483 x 88 x 343 mm)
Weight (Approx.):	21.4 lbs. (9.7 kg)

Receiver

Antenna Impedance:	50 ohm
Antenna Connector:	Type-BNC
Receiver Type:	Double-Conversion Superheterodyne
Sensitivity:	0.3 μ V (12dB SINAD), 0.45 μ V (20dB Noise Quieting)
Adjacent Channel Selectivity:	80 dB (Wide), 75 dB (Narrow)
Intermodulation:	82 dB (Wide), 78 dB (Narrow)
Image Rejection:	90 dB
Squelch Threshold:	-5 dB μ
Audio Output:	4 W @4 ohm
Audio Distortion:	< 3 %
Hum and Noise:	> 50 dB (Wide), > 45 dB (Narrow)
Audio Frequency Response:	De-emphasis : 6 dB/oct (From 300 Hz to 3 kHz)
Conducted Spurious:	< -80 dBm

Transmitter

RF Output Power:	50/25/10 W (High/Mid/Low)
Antenna Impedance:	50 ohm
Antenna Connector:	Type-N
Modulation Type:	16K0F3E/11K0F3E
System Deviation:	\pm 5.0 kHz (Wide), \pm 2.5 kHz (Narrow)
Hum and Noise:	>46 dB (Wide), >43 dB (Narrow)
Microphone Sensitivity:	5 mV
Audio Frequency Response:	Pre-emphasis : 6dB/oct (From 300 Hz to 3 kHz)
Spurious Emission:	70 dB below carrier
Audio Distortion:	<2.5 % @1 kHz
Microphone Impedance:	600 ohm

100 W PA Unit (Option)

Frequency Range:	450 - 490 MHz
Antenna Impedance:	50 ohm
Antenna Connector:	Type-N
RF Output Power:	100/75/50 W (High/Mid/Low)
Duty Cycle:	100 % (@Cooling Fan "ON")
Spurious Emission:	75 dB below carrier
Operating Voltage:	13.6 V DC \pm 10 %
Current Drain:	30 A Maximum
Operating Temperature Range:	-22 °F to +140 °F (-30 °C to +60 °C)

Specifications subject to change without notice or obligation.

DSUB 25-pin Accessory Connector

The **VXR-9000** repeater is provided with a 25-pin DB-25F female connector for interconnections to accessories. Use a DB-25M 25-pin male connector to connect accessories to the repeater. The pins on the accessory connector are explained in detail as follows:

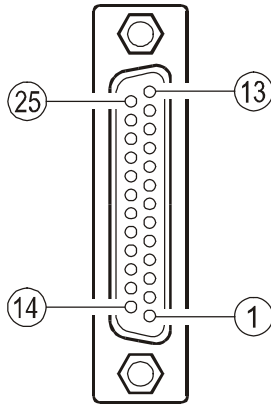

DB-25 PIN NUMBERING

Pin 1: GND

Chassis ground for all logic levels and power supply return.

Pin 2: +13.6 V

[POWER SUPPLY]

This pin provides 13.6 Volts, 2.0 A, DC from the repeater supply. There is an internal 3 A fuse to prevent damage to the repeater.

Pin 3: TX AF IN

[ANALOG TRANSMITTER INPUT] (VOICE BAND: 300 ~ 3,000 Hz)

This pin is s audio input. Input impedance is 600 Ohms. This audio is injected before the splatter filter stage, so excess signal input levels are clipped.

Use shielded cable to connect to this pin, and connect the shield to GND.

Pin 4: TONE IN

[TRANSMITTER INPUT] (SUB-AUDIBLE BAND: 5 ~ 250 Hz)

This pin is sub-audible tone produces 10% of full system deviation. The nominal input voltage is 77.5 mVrms. The input impedance is @600 Ohms, and has a flat response characteristic (repeater deviation is constant for a given signal level over the frequency range of 5 ~ 250 Hz). Injecting too high a voltage here causes over-deviation of CTCSS or DCS, degrading performance. Use shielded cable to connect to this pin, connecting the shield to GND.

Pin 5: TX ATT

This output is intended for controlling an external coaxial switching relay. It is an open drain output which can sink approx. 1.5 A when active. The delay time which is between the repeater cause to transmit mode and this port switches to ground can be programmed by your VERTEX STANDARD dealer.

Pin 6: DISC OUT

[ANALOG OUTPUT] (WIDE-BAND: 0 ~ 3,000 Hz)

Received signals with full system deviation produce 350 mVrms audio at this pin. The output impedance is 600 Ohm, and is extracted before the de-emphasis and squelch circuitry. Use shielded cable to connect to this pin, and connect the shield to GND.

Pin 7: N.C.

No connection.

Pin 8: RSSI

[ANALOG OUTPUT]

A DC voltage proportional to the strength of the signal currently being received (Receiver Signal Strength Indicator) is provided on this pin. This low impedance output is generated by the receiver IF sub-system and buffered by an internal op-amp. Typical voltages are graphed as follows:

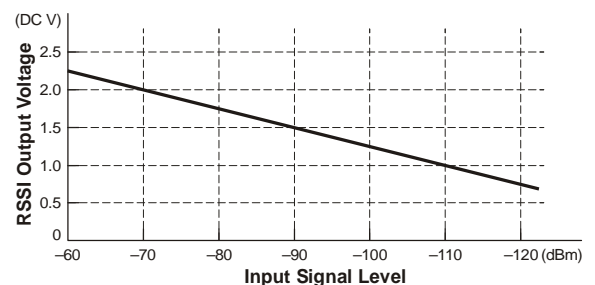

Pin 9: COAX. SW

[LOGIC OUTPUT (ACTIVE LOW)]

This output is intended for controlling an external coaxial switching relay. It is an open drain output which can sink approx. 1.5 A when active. This signal only switches if the repeater has been programmed for "SIMPLEX" mode. If programmed for "DUPLEX," the signal remains open (high impedance) at all time.

DSUB 25-pin Accessory Connector

Pin 10, 13, 15, 16, 17, 18, 19, 21:

PROGRAMMABLE I/O "1" ~ "8"

The **VXR-9000** provides eight ports (PIO) that can be programmed for various input or output signals, or for control functions. Each port may be programmed as to its function, its status (input or output), and its logic (for output ports only). See Tables on the next page for detail regarding the input and output signals.

Pin	I/O Port
10	7
13	8
15	5
16	4
17	3
18	2
19	1
21	6

Pin 11: NSQ DET

This is an open-collector, active-low output capable of sinking about 10 mA. It indicates that the receiver squelch is open. If the squelch control is properly set, this indicates a carrier on the receiver channel.

Pin 12: EXT PTT

This input is internally pulled up to 5 VDC. When pulled low by an external device, it keys the repeater transmitter while the repeater is operating in the "Remote" mode. Avoid voltage in excess of 5 V on this pin, or internal damage to the microprocessor on the repeater CNTL Unit may result.

Pin 14, 20: GND

Chassis ground for all logic levels and power supply return.

Pin 22: RXD LOW

[ANALOG OUTPUT FOR DATA COMMUNICATIONS]

(300 ~ 3,000 Hz)

This pin is an output for low speed receiving data signals (typically 1200 bps), with the data being extracted after the de-emphasis and low pass filter stages.

Pin 23: RXD HIGH

[DIGITAL OUTPUT FOR DATA COMMUNICATIONS]

(Max.: 5 kHz)

This pin is an output for high speed receiving data signals (typically 9600 bps), with the data being extracted immediately after the discriminator (prior to any de-emphasis).

Pin 24: TXD LOW

[ANALOG INPUT FOR DATA COMMUNICATIONS]

(300 ~ 3,000 Hz)

This pin is intended to be used as a low speed data signal input to the repeater (typically 1200 bps). This digital data signal is injected before the transmitter pre-emphasis and limiting stages, so excess signal input levels are clipped.

Pin 25: TXD HIGH

[DIGITAL INPUT FOR THE DATA COMMUNICATIONS]

(0 ~ 5 kHz)

This pin is intended to be used as a high speed digital data signal input to the repeater (typically 9600 bps). This digital data signal is injected after the transmitter splatter filter stage.

CHANNEL STEERING CHART

OPERATING CHANNEL	Bin CH					OPERATING CHANNEL	Bin CH				
	4	3	2	1	0		4	3	2	1	0
1	1	1	1	1	1	17	0	1	1	1	1
2	1	1	1	1	0	18	0	1	1	1	0
3	1	1	1	0	1	19	0	1	1	0	1
4	1	1	1	0	0	20	0	1	1	0	0
5	1	1	0	1	1	21	0	1	0	1	1
6	1	1	0	1	0	22	0	1	0	1	0
7	1	1	0	0	1	23	0	1	0	0	1
8	1	1	0	0	0	24	0	1	0	0	0
9	1	0	1	1	1	25	0	0	1	1	1
10	1	0	1	1	0	26	0	0	1	1	0
11	1	0	1	0	1	27	0	0	1	0	1
12	1	0	1	0	0	28	0	0	1	0	0
13	1	0	0	1	1	29	0	0	0	1	1
14	1	0	0	1	0	30	0	0	0	1	0
15	1	0	0	0	1	31	0	0	0	0	1
16	1	0	0	0	0	32	0	0	0	0	0

DSUB 25-pin Accessory Connector

PROGRAMMABLE I/O PORT INPUT ITEMS

Item	Function	Item	Function
Bin_CH_0	Recall the Memory Channel (Binary LSB)	Monitor_On	Turn the Monitor Function "On"
Bin_CH_1	Recall the Memory Channel (Binary)	Monitor_Off	Turn the Monitor Function "Off"
Bin_CH_2	Recall the Memory Channel (Binary)	Monitor_Toggle	Turn the Monitor Function "On" or "Off" (Toggle)
Bin_CH_3	Recall the Memory Channel (Binary)	Monitor_M	Turn the Monitor Function "On" when the I/O port is "High"
Bin_CH_4	Recall the Memory Channel (Binary MSB)	Multi_Tone_Main	Select the Tone Table to "Main"
Channel_Down	Step to the next-lower Operating Channel	Multi_Tone_Sub	Select the Tone Table to "Sub"
Channel_Up	Step to the next-higher Operating Channel	Multi_Tone_Toggle	Switch the Tone Table between "Main" and "Sub" (Toggle)
Compander_On	Turn the Compander Circuit "On"	Panel_Indicator_On	Turn the Front Panel's Illumination "On"
Compander_Off	Turn the Compander Circuit "Off"	Panel_Indicator_Off	Turn the Front Panel's Illumination Off
Compander_Toggle	Turn the Compander Circuit "On" or "Off" (Toggle)	Panel_Indicator_Toggle	Turn the Front Panel's Illumination "On" or "Off" (Toggle)
CTCSS/DCS_Enc_On	Turn the CTCSS/DCS Encoder "On"	Repeat_On	Set the Operating Mode to "Repeat" mode
CTCSS/DCS_Enc_Off	Turn the CTCSS/DCS Encoder "Off"	Repeat_Off	Set the Operating Mode to "Base" mode
CTCSS/CS_Enc_Toggle	Turn the CTCSS/DCS Encoder "On" or "Off" (Toggle)	Repeat_Toggle	Toggle the Operating Mode between the "Repeat" mode and "Base" mode
CTCSS/DCS_Dec_On	Turn the CTCSS/DCS Decoder "On"	Reset	Reset the Repeater
CTCSS/DCS_Dec_Off	Turn the CTCSS/DCS Decoder "Off"	Scan_On	Start Scanning
CTCSS/CS_Dec_Toggle	Turn the CTCSS/DCS Decoder "On" or "Off" (Toggle)	Scan_Off	Stop Scanning
Two_Tone_Dec_On	Turn the 2-Tone Decoder "On"	Scan_Toggle	Toggle the Scanner between "Start" and "Stop"
Two_Tone_Dec_Off	Turn the 2-Tone Decoder "Off"	Squelch_On	Turn the Squelch Circuit "On (Close)"
Two_Tone_Dec_Toggle	Turn the 2-Tone Decoder "On" or "Off" (Toggle)	Squelch_Off	Turn the Squelch Circuit "Off (Close)"
CW_ID_On	Turn the CW IDer "On"	Squelch_Toggle	Turn the Squelch Circuit "On" or "Off" (Toggle)
CW_ID_Off	Turn the CW IDer "Off"	Test_Tone_On	Generate the Test Tone Signal
CW_ID_Toggle	Turn the CW IDer "On" or "Off" (Toggle)	Test_Tone_Off	Stop the generation of the Test Tone
CW_ID_Single	Transmit the CW ID	Test_Tone_Toggle	Toggle the Test Tone generation "On" and "Off"
CW_Message_1	Send the CW Message 1	Test_Tone_M	Generate the Test Tone Signal when the I/O port is "High"
CW_Message_2	Send the CW Message 2	TOT_On	Turn the Time-Out Timer feature "On"
CW_Message_3	Send the CW Message 3	TOT_Off	Turn the Time-Out Timer feature "Off"
CW_Message_4	Send the CW Message 4	TOT_Toggle	Turn the Time-Out Timer feature "On" or "Off"
CW_Message_5	Send the CW Message 5	Transmit_On	Enable the transmission of the Repeater
CW_Message_6	Send the CW Message 6	Transmit_Off	Disable the transmission of the Repeater
CW_Message_7	Send the CW Message 7	Transmit_Toggle	Enable/Disable the transmission of the Repeater
CW_Message_8	Send the CW Message 8	TX_Power_Mid_On	Set the transmitter power to the "Mid" level
CW_Message_Bin_0	CW Message Recall (Binary LSB)	TX_Power_Mid_Off	Return the transmitter power to "Original" power level
CW_Message_Bin_1	CW Message Recall (Binary)	TX_Power_Mid_Toggle	Toggle the transmitter power between the "Mid" level and "Original" power level
CW_Message_Bin_2	CW Message Recall (Binary MSB)	TX_Power_Low_On	Set the transmitter power to the "Low" level
CW_Message_Bin_Trig	Send the CW Message which is recalled from I/O port	TX_Power_Low_Off	Return the transmitter power to "Original" power level
DC_Power_Save_On	Turn the DC Power Save Feature "On"	TX_Power_Low_Toggle	Toggle the transmitter power between the "Low" level and "Original" power level
DC_Power_Save_Off	Turn the DC Power Save Feature "Off"		
DC_Power_Save_Toggle	Turn the DC Power Save Feature "On" or "Off" (Toggle)		
Encryption_On	Turn the Encryption Circuit "On"		
Encryption_Off	Turn the Encryption Circuit "Off"		
Encryption_Toggle	Turn the Encryption Circuit "On" or "Off" (Toggle)		
Encryption_Code	Select the Encryption Code		
Local_PTT_On	Enable the Local PTT Switch		
Local_PTT_Off	Disable the Local PTT Switch		
Local_PTT_Toggle	Enable/Disable the Local PTT Switch (Toggle)		

PROGRAMMABLE I/O PORT OUTPUT ITEMS

Item	Function	Item	Function
Remote_Enb	Output the signal when the Operating mode is set to "Repeat" mode.	Power_Supply_Backup	Output the signal when the backup power source is used.
Busy	Output the signal when the squelch is opened.	Power_Supply_Voltage	Output the signal when the main power source is used.
CTCSS_Correspond	Output the signal when the receiving CTCSS tone is matched.	Transmit	Output the signal when the repeater is transmitting.
DCS_Correspond	Output the signal when the receiving DCS code is matched.	Fan_Alarm	Output the signal when the Coolig Fan is disabled.
CTCSS/DCS_Correspond	Output the signal when the receiving CTCSS tone or DCS code is matched.	Fan_Status	Output the signal when the Coolig Fan is activated.
RX_Unlock	Output the signal when the RX PLL Circuit is Unlocked.	High_Temperature	Output the signal when the PA Unit is High Temperature.
TX_Unlock	Output the signal when the TX PLL Circuit is Unlocked.	TX_PD_Det	Output the signal when the TX power is abnormality.
PLL_Unlock	Output the signal when the TX or RX PLL Circuit is Unlocked.	Answer_Back	Output the signal when the repeater status is changed from the Remote Control command.

DSUB 25-pin Accessory Connector

Note:

Exploded View & Miscellaneous Parts (Lot. 1 ~ 20)

(PA-Unit: Discrete Type)

REF.	VXSTD P/N	DESCRIPTION	QTY.
①	U00508001	PAN HEAD SCREW M5X8	4
②	U30408007	FLAT HEAD SCREW M4X8B	8
③	U51416007	HEXA SOCKET BOLT M4X16B	2
④	U20208002	BINDING HEAD SCREW M2.6X8NI	2
⑤	U20406002	BINDING HEAD SCREW M4X6NI	14
⑥	U20410002	BINDING HEAD SCREW M4X10NI	4
⑦	U04408001	SEMS SCREW HSM4X8	8
⑧	U24206001	TAPTITE SCREW M2.6X6	3
⑨	U23308001	TAPTITE SCREW M3X8	12
⑩	U04306002	SEMS SCREW HSM3X6NI	2
⑪	U20305002	BINDING HEAD SCREW M3X5NI	12
⑫	U24308001	TAPTITE SCREW M3X8	13
⑬	U24310001	TAPTITE SCREW M3X10	8
⑭	U52408002	HEX HEAD BOLT M4X8NI	1
⑮	U72004002	TOOTHED LOCK WASHER OW4NI	1
⑯	U20308002	BINDING HEAD SCREW M3X8NI	2

ACCESSORIES	
VXSTD P/N	DESCRIPTION
Q0000075	BLADE FUSE
T9023499	DC CABLE
RA0508500	NAME PLATE
RA0506900	KNOB CAP

Non-designated parts are available only as part of a designated assembly.

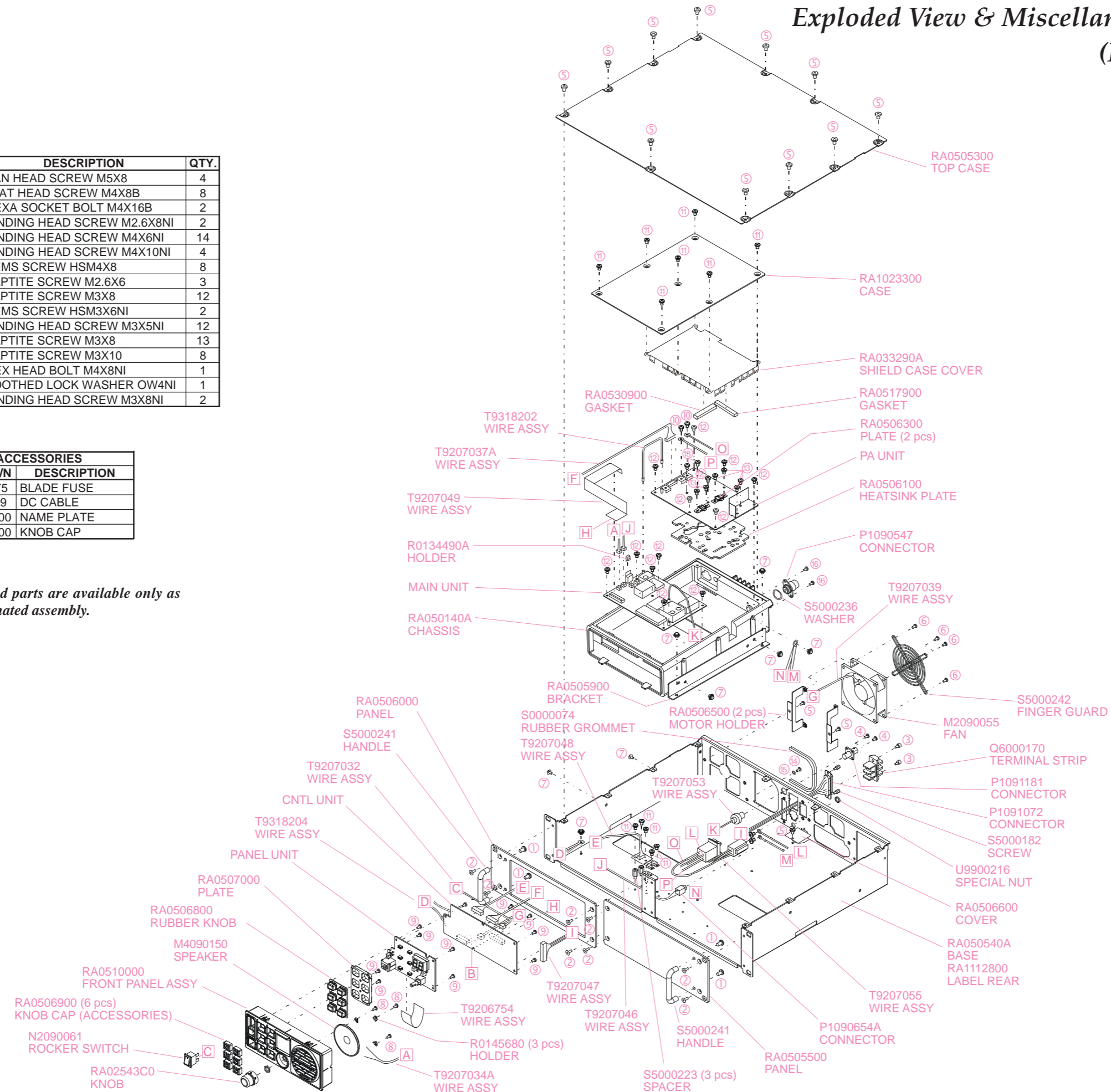

Exploded View & Miscellaneous Parts (Lot. 21 ~)

(PA-2 Unit: Power Module Type)

REF.	VXSTD P/N	DESCRIPTION	QTY.
①	U00508001	PAN HEAD SCREW M5X8	4
②	U30408007	FLAT HEAD SCREW M4X8B	8
③	U51416007	HEXA SOCKET BOLT M4X16B	2
④	U20208002	BINDING HEAD SCREW M2.6X8NI	2
⑤	U20406002	BINDING HEAD SCREW M4X6NI	14
⑥	U20410002	BINDING HEAD SCREW M4X10NI	4
⑦	U04408001	SEMS SCREW HSM4X8	8
⑧	U24206001	TAPTITE SCREW M2.6X6	3
⑨	U23308001	TAPTITE SCREW M3X8	12
⑩	U04306002	SEMS SCREW HSM3X6NI	5
⑪	U20305002	MBINDING HEAD SCREW M3X5NI	9
⑫	U24308001	TAPTITE SCREW M3X8	6
⑬	U24310001	TAPTITE SCREW M3X10	6
⑭	U52408002	HEX HEAD BOLT M4X8NI	1
⑮	U72004002	TOOTHED LOCK WASHER OW4NI	1
⑯	U20308002	BINDING HEAD SCREW M3X8NI	2

ACCESSORIES	
VXSTD P/N	DESCRIPTION
Q0000075	BLADE FUSE
T9023499	DC CABLE
RA0508500	NAME PLATE
RA0506900	KNOB CAP

Non-designated parts are available only as part of a designated assembly.

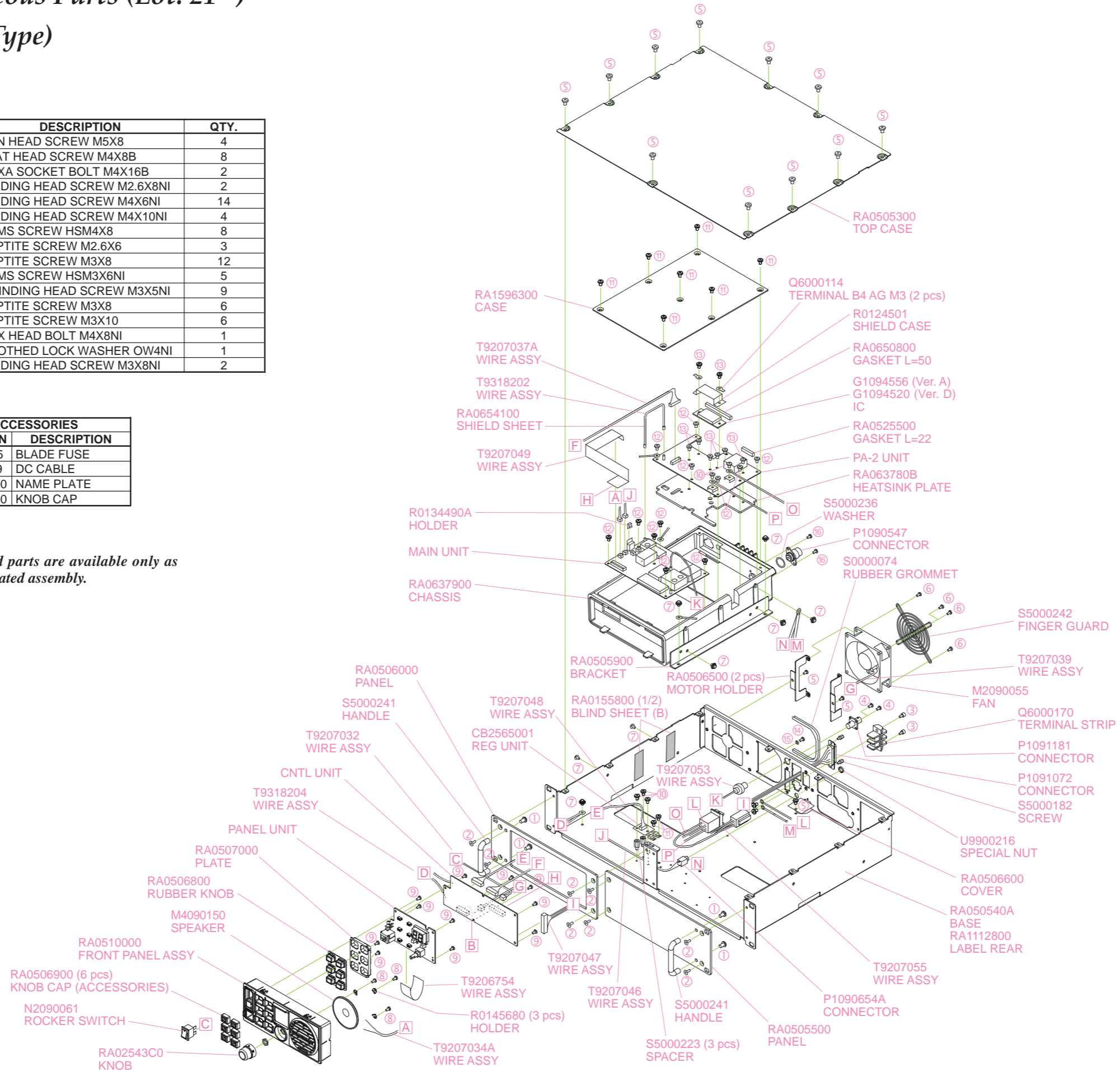

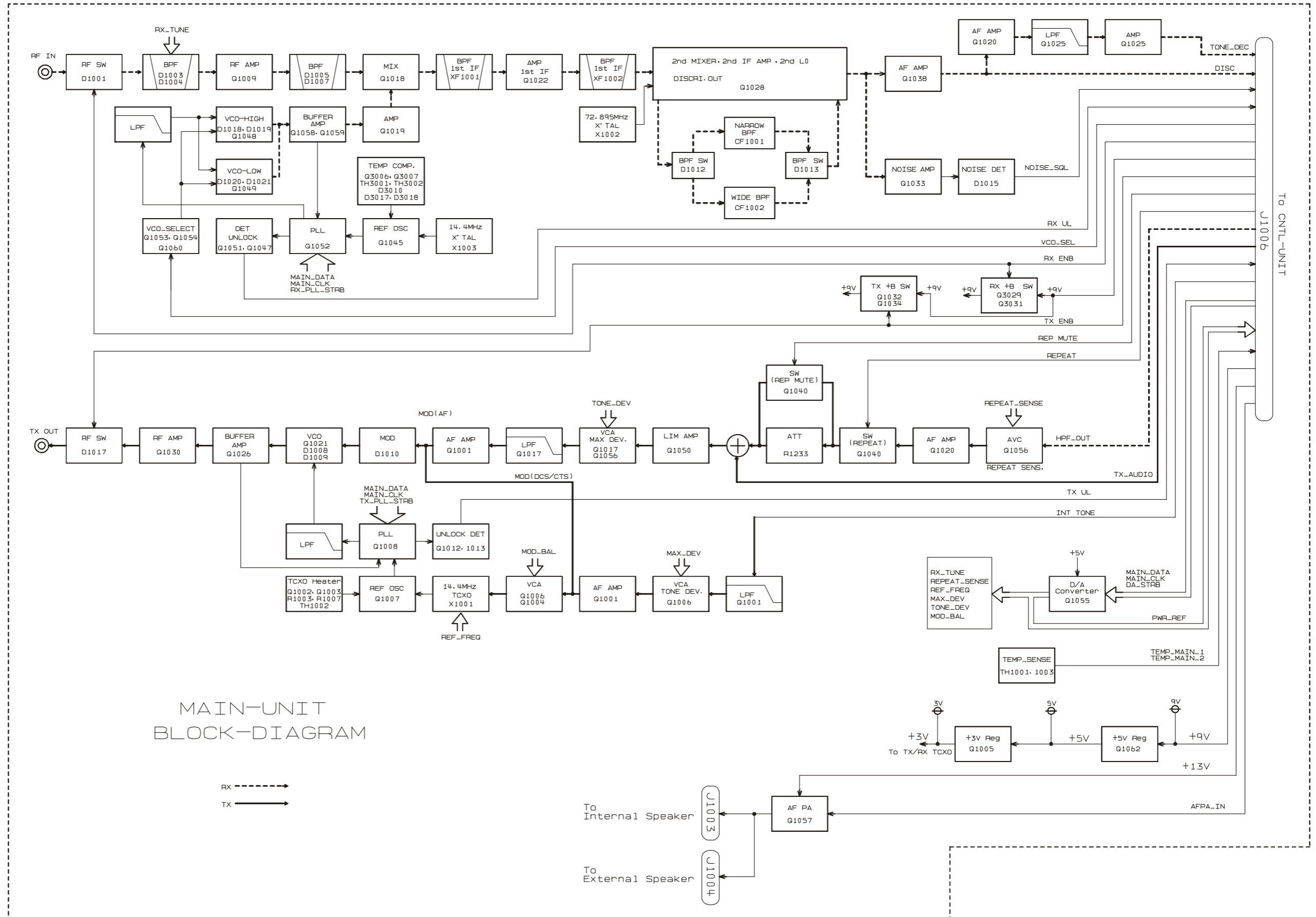

MAIN-UNIT
BLOCK-DIAGRAM

Block Diagram

CNTL Unit, PANEL Unit, & PA Unit

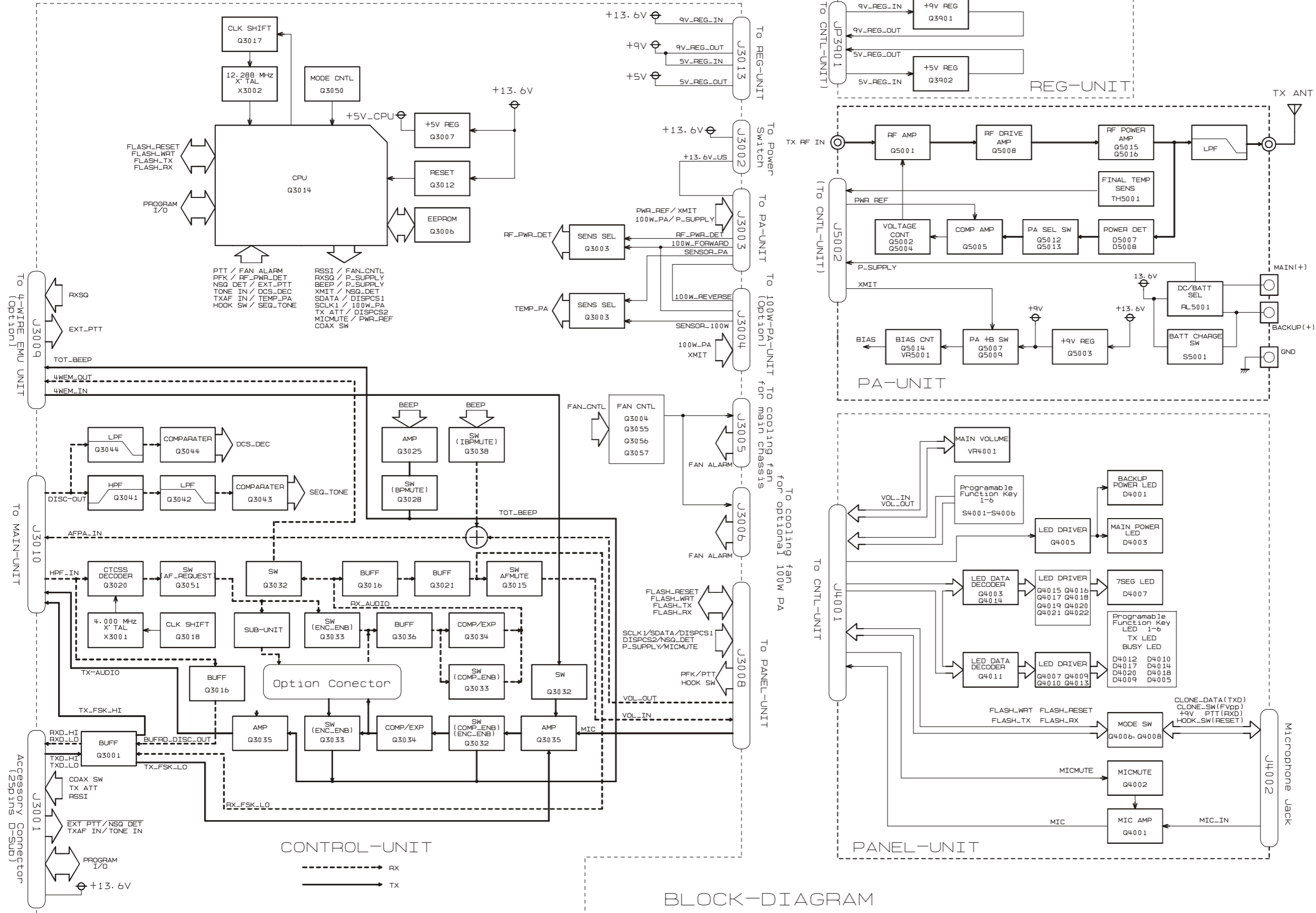

BLOCK-DIAGRAM

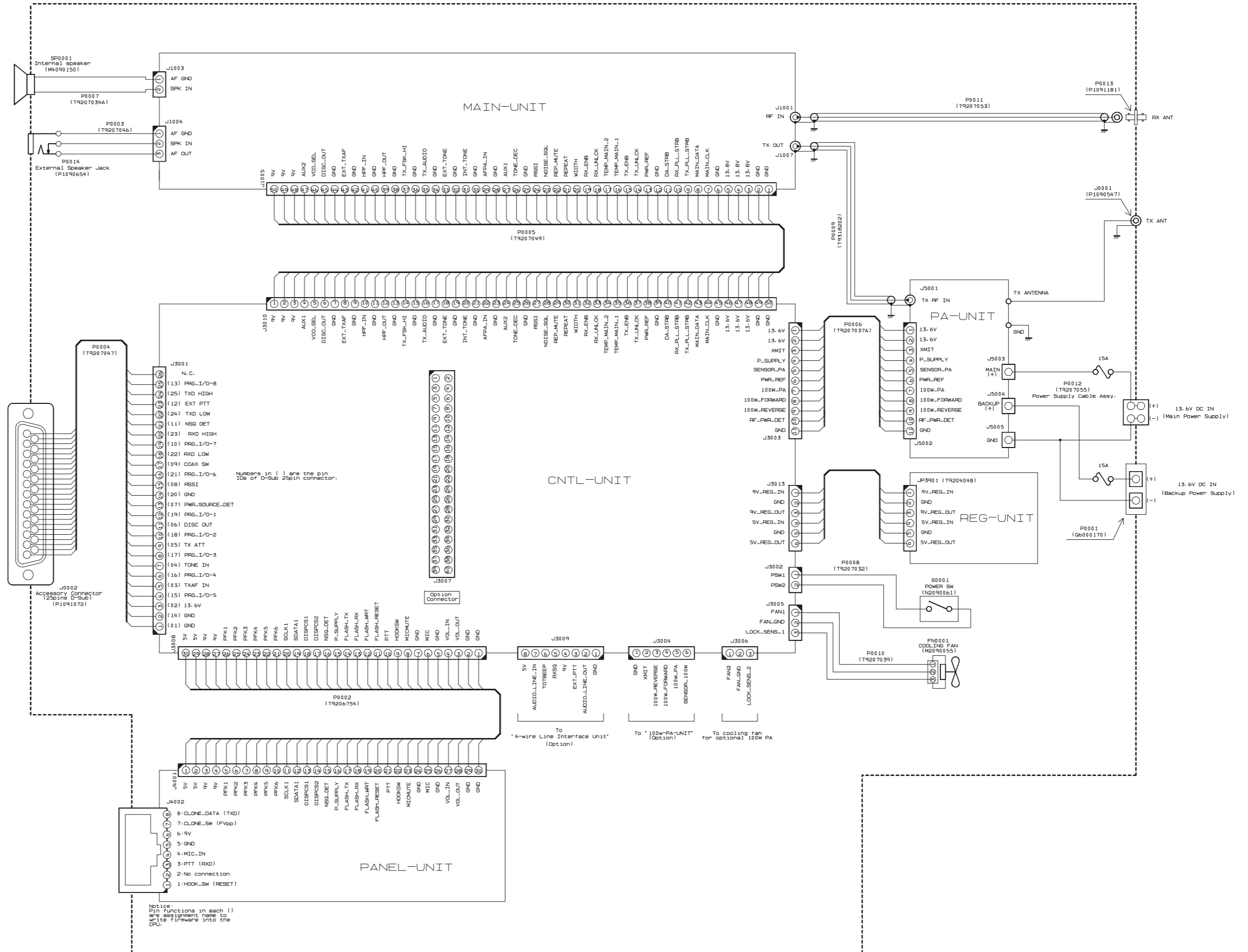

Connection Diagram (with Optional 100 W PA Unit)

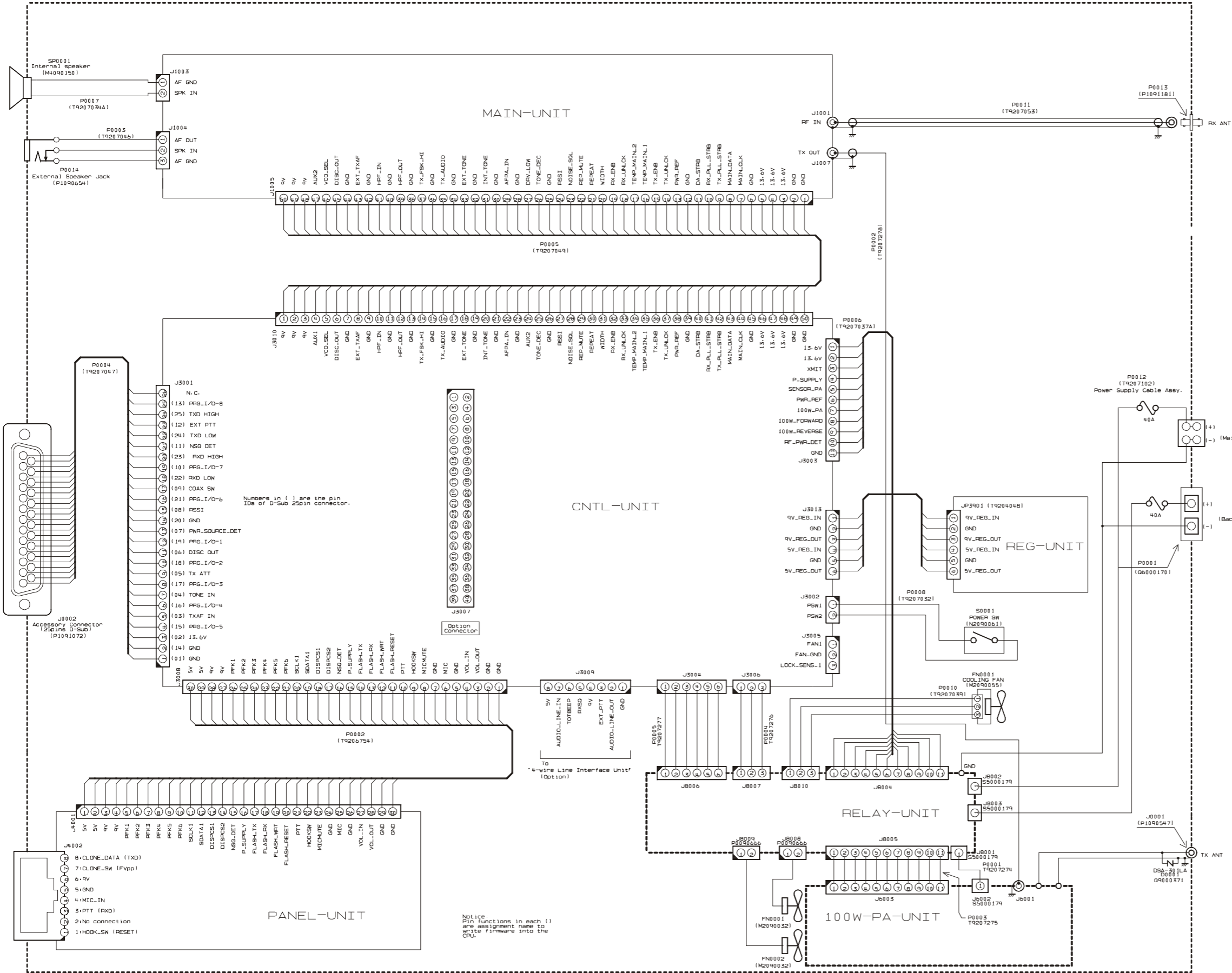

RECEIVE SIGNAL PATH

Incoming RF from the RX antenna jack is delivered to the MAIN Unit and passes through the protection diode **D1001 (1SS302)** and a varactor-tuned band pass filter consisting of coils L1003 and L1004, capacitors C1015, C1018, C1021, C1032, and C1044, and diodes **D1003** and **D1004** (both **HVU350**). Signals are then applied to the RF amplifier, **Q1009 (2SC3357)**. The amplified RF signal is applied through a varactor-tuned band pass filter consisting of coils L1010 and L1011, capacitors C1079, C1092, C1082, C1095 and C1075, and diodes **D1007** and **D1005** (both **HVU350**) to the first mixer **Q1018 (SPM5001)** along with the first local signal from the PLL circuit.

The first local signal is generated between 376.65 MHz and 416.65 MHz by the RX VCO, which consists of FET **Q1048 (2SK508)** and varactor diodes **D1018** and **D1019** (both **1SV282**) or FET **Q1049 (2SK508)** and varactor diodes **D1020** and **D1021** (both **1SV282**), according to the programmed receiving frequency; the local signal then passes through buffer amplifier **Q1059 (2SC5226)** and first local amplifier **Q1019 (2SC3357)** to the first mixer **Q1018 (SPM5001)**.

The 73.35 MHz first IF signal is applied to monolithic crystal filters **XF1001** and **XF1002** which strip away unwanted mixer products, and the IF signal is applied to the first IF amplifiers **Q1022 (2SC5226)**. The amplified first IF signal is then delivered to the FM IF subsystem IC **Q1028 (TA31136FN)**, which contains the second mixer, second local oscillator, limiter amplifier, noise amplifier, and FM detector.

The second local oscillator signal, generated by the 72.895 MHz crystal **X1002**, produces the 455 kHz second IF signal when mixed with the first IF signal within **Q1028 (TA31136FN)**. The second IF signal passes through ceramic filter **CF1001** or **CF1002** which strips away all but the desired signal, and then passes through the limiter amplifier within **Q1028 (TA31136FN)** to ceramic discriminator **CD1001**, which removes any amplitude variations in the 455 kHz IF signal before detection of speech. The detected audio passes through the low pass filter, consisting of R1199 and C1244, which rejects the 455 kHz IF component.

The audio signal from the MAIN Unit is delivered to the CNTL Unit and passes through the audio amplifier **Q1020 (NJM2904V)** to the active high pass filter section of **Q3020 (FX805LG)**, which rejects the sub-audible frequency component. The filtered audio signal is delivered to electronic volume **Q1056**, which adjusts the audio sensitivity to compensate for audio level variations, then passes through audio amplifier **Q1020 (NJM2904V)**, audio switch **Q1040 (BU4066BCFV)**, attenuator consisting of R1233, and limiter amplifier **Q1050 (NJM2904V)**, to the electronic vol-

ume control **Q1056 (M51132FP)**, where the maximum deviation is set. The audio signal subsequently passes through the 3-section active low pass filter consisting of **Q1017-1/-2/-3 (NJM2902V)** and audio amplifier **Q1001 (NJM2902V)** to providing the repeater transmit audio.

A portion of the audio signal from the active high pass filter section of **Q4024 (NJM2902V)** is de-emphasized consisting of **Q3036 (TA75S01F)**, R3198, and C3144, providing a flat audio response. The filtered audio then passes through the active band pass filter **Q3021 (NJM2902V)** and audio mute gate **Q3015 (DTC323TK)** to audio power amplifier **Q1057 (TDA2003)**, providing up to 2 Watts of audio power to the 8 Ohm loudspeaker.

SUB-AUDIBLE SIGNALING (DECODER)

A portion of the audio signal from the audio amplifier **Q1020 (NJM2904V)** passes through the 3-section active low pass filter **Q1025 (NJM2902V)** and the low pass filtering section of **Q3020 (FX805LG)** to separate the CTCSS tones from the received audio signal. The CTCSS tones are sent to the CTCSS decoder section of **Q3020 (FX805LG)**. When a CTCSS tone is received, the CTCSS information is delivered to pin 77 of the Main CPU **Q3014 (HD64F2238)** from pin 4 and 8 of **Q3020 (FX805LG)** which compares the CTCSS tone with the programmed tone.

Another portion of the audio signal passes through the 3-section active low pass filter **Q3044 (NJM2902V)** to separate the DCS codes from the received audio signal. The low pass filtered signal passes through the phase detector **Q3044 (NJM2902V)** to pin 39 of the Main CPU **Q3014 (HD64F2238)**. When a DCS code is received, the Main CPU **Q3014 (HD64F2238)** compares the DCS code with the programmed code.

If the received CTCSS tone or DCS code matches the programmed tone or code, pin 4 of the Main CPU **Q3014 (HD64F2238)** goes low, turning off the squelch switch **Q3015 (DTC323TK)** and passing the received audio signal to the audio power amplifier **Q1057 (TDA2003V)**.

SQUELCH CONTROL

The squelch circuit consists of noise amplifier **Q1033 (2SC4116GR)** and noise detector **D1015 (MA143)** on the MAIN Unit, and control circuitry within Main CPU **Q3014 (HD64F2238)** on the CNTL Unit.

When no carrier is received, noise at the output of the audio detector stage of **Q1028 (TA31136FN)** is amplified by **Q1033 (2SC4116GR)**, and then rectified by **D1015 (MA143)** to provide a DC control voltage for the squelch switch. The resulting DC voltage is delivered to pin 23 of J1005.

The DC voltage from the MAIN Unit is delivered to the A-D analog input port (pin 51) of the Main CPU **Q3014 (HD64F2238)** on the CNTL Unit, which compares the

Circuit Description

squelch threshold level to that which is memorized in EEPROM Q3006 (BR24L32F) or set by the front panel SQL control.

RX PLL AND VCO CIRCUITS

The receiver's PLL circuitry consists of PLL subsystem IC Q1052 (MB15A02PFV1) on the MAIN Unit, which contains a reference oscillator/divider, serial-to-parallel data latch, programmable divider, phase comparator and a swallow counter. Stability is obtained by a regulated 5 VDC supply via Q1062 (L78M05T) and temperature compensated 14.4 MHz crystal oscillator X1003.

The RX VCO made up two VCO circuit, one is Low-Band RX VCO, consisting of FET Q1048 (2SK508) and varactor diodes D1018 and D1019 (both 1SV282), and another one is High-Band RX VCO, consisting of FET Q1049 (2SK508) and varactor diodes D1020 and D1021 (both 1SV282), oscillates between 376.65 MHz and 416.65 MHz according to the programmed receiving frequency. The RX VCO output passes through buffer amplifier Q1059 (2SC5226) and first local amplifier Q1019 (2SC3357) to the first mixer Q1018 (SPM5001), as described previously. A portion of the RX VCO output is applied to the prescaler/swallow counter section in the PLL IC Q1052 (MB15A02PFV1). There the RX VCO signal is divided by 64 or 65, according to a control signal from the Main CPU Q3014 (HD64F2238) on the CNTL Unit, before being applied to the programmable divider section of the PLL IC Q1052 (MB15A02PFV1).

The data latch section of the PLL IC Q1052 (MB15A02PFV1) also receives serial dividing data from the Main CPU Q3014 (HD64F2238), which causes the pre-divided RX VCO signal to be further divided by 75,330 ~ 81,330 (or 60,264 ~ 65,064) in the programmable divider section in the PLL IC Q1052 (MB15A02PFV1), depending upon the desired receive frequency, so as to produce a 5 kHz (or 6.25 kHz) derivative of the current RX VCO frequency. Meanwhile, the reference divider section of the PLL IC Q1052 (MB15A02PFV1) divides the 14.4 MHz crystal reference from the reference oscillator X1003 and Q1045 (2SC4116GR) by 2880 (or 2304) to produce the 5 kHz (or 6.25 kHz) loop reference.

The 5 kHz or 6.25 kHz signal from the programmable divider (derived from the RX VCO) and that derived from the crystal are applied to the phase detector section of the PLL IC Q1052 (MB15A02PFV1), which produces a pulsed output with pulse duration depending on the phase difference between the input signals. This pulse train is then converted to DC, low pass filtered, then fed back to the RX VCO varactor diodes D1018/D1019 and D1020/D1021 (all 1SV282).

Changes in the DC voltage applied to the varactor diodes

D1018/D1019 and D1020/D1021 (all 1SV282) affect the reactance in the tank circuit RX VCO Q1048/1049 (both 2SK508), changing the oscillating frequency according to the phase difference between the signals derived from the RX VCO and the crystal reference oscillator. The RX VCO is thus phase-locked to the reference frequency standard.

TRANSMIT SIGNAL PATH

The speech audio from the CNTL Unit is applied to the varactor diode D1010 (HVU350), which frequency modulates the TX VCO from the unmodulated carrier at the transmit frequency. The modulated transmit signal is buffered by Q1026 (2SC5226), then passes through the RF amplifier Q1030 (2SC3357) and RF diode switch D1016 (RN739F) to the PA Unit.

The transmit signal is applied to the RF amplifier Q5001 (2SC3357) and Q5008 (PD55008), then finally amplified by power amplifier Q5015 and Q5016 (both PD55025S) up to 50 Watts. Harmonic and spurious radiation in the final output is suppressed by a low pass filter consisting of coils L5007 ~ L5010, plus capacitors C5071, C5078, C5082, C5085, and C5088 on the PA Unit, before delivery to the TX antenna jack.

TX PLL AND VCO CIRCUITS

The Transmitter's PLL circuitry consists of PLL subsystem IC Q1008 (MB15A02PFV1) on the MAIN Unit, which contains a reference oscillator/divider, serial-to-parallel data latch, programmable divider, phase comparator and a swallow counter. Stability is obtained by a regulated 5 VDC supply via Q1062 (L78M05T) and temperature compensated 14.4 MHz crystal oscillator X1001.

The TX VCO, consisting of FET Q1021 (2SK508) and varactor diodes D1008 and D1009 (both 1SV282), oscillates between 450 MHz and 490 MHz according to the programmed transmit frequency. The theory of operation of the remainder of the PLL circuitry is similar to that of the RX PLL circuit; however, dividing data from the Main CPU Q3014 (HD64F2238) on the CNTL Unit is such that the VCO frequency is the actual transmit frequency.

APC (AUTOMATIC POWER CONTROL)

RF power output from the final amplifier Q5015/Q5016 (both PD55025S) is sampled by C5061/C5056 and is then rectified by D5007 and D5008 (both HSM88AS). The resulting DC voltage is applied to the comparator Q5005 (TA75S01F), where the voltage is compared with a reference voltage from the Main CPU Q3014 (HD64F2238) on the CNTL Unit, to produce a control voltage for the Automatic Power Controller Q5004 (2SC4116GR) and Q5002 (2SB1122S), which regulates supply voltage to Q5001 (2SC3357).

CNTL (CONTROL) UNIT

The CNTL Unit consists of 8-bit CPU **Q3014 (HD64F2238)**, EEPROM **Q3006 (BR24L32F)**, RX and TX speech audio circuits, and various analog switches for the CPU and repeater interconnections.

Microprocessor operational code is stored in **Q3006 (BR24L32F)**, while channel data and repeater configuration information is programmed from an external PC connected to the front panel's **MIC** jack via a VPL-1 programming cable.

The output from the Main CPU **Q3014 (HD64F2238)** contains serial control data used for REPEATER/BASE mode control, as well as TX and RX PLL data. Crystal **X3002** oscillates at 12.288 MHz, and provides stable clock timing for the Main CPU. When the repeater is powered on, the voltage at pin 62 of **Q3014 (HD64F2238)** becomes stable, and the output of voltage detector IC **Q3012 (BD4845FVE)**, which is tied to pin 59 (RST) of **Q3014 (HD64F2238)** becomes high, resetting the Main CPU.

BASE OPERATION (TX, MIC-INPUT AUDIO)

Microphone input is delivered past the MIC MUTE switch **Q4002 (DTC323TK)**, then passes through the audio amplifier and active high pass filter at **Q4001 (NJM2902V)** when the signal is processed in the same manner as previously described.

Circuit Description

Note:

Introduction

The VXR-9000 has been aligned at the factory for the specified performance across the entire frequency range specified. Realignment should therefore not be necessary except in the event of a component failure. All component replacement and service should be performed only by an authorized Vertex Standard representative, or the warranty policy may be voided.

The following procedures cover the sometimes critical and tedious adjustments that are not normally required once the transceiver has left the factory. However, if damage occurs and some parts are replaced, realignment may be required. If a sudden problem occurs during normal operation, it is likely due to component failure; realignment should not be done until after the faulty component has been replaced.

We recommend that servicing be performed only by authorized Vertex Standard service technicians who are experienced with the circuitry and fully equipped for repair and alignment. Therefore, if a fault is suspected, contact the dealer from whom the transceiver was purchased for instructions regarding repair. Authorized Vertex Standard service technicians realign all circuits and make complete performance checks to ensure compliance with factory specifications after replacing any faulty components. Those who do undertake any of the following alignments are cautioned to proceed at their own risk. Problems caused by unauthorized attempts at realignment are not covered by the warranty policy. Also, Vertex Standard must reserve the right to change circuits and alignment procedures in the interest of improved performance, without notifying owners. Under no circumstances should any alignment be attempted unless the normal function and operation of the transceiver are clearly understood, the cause of the malfunction has been clearly pinpointed and any faulty components replaced, and the need for realignment determined to be absolutely necessary. The following test equipment (and thorough familiarity with its correct use) is necessary for complete realignment. Correction of problems caused by misalignment resulting from use of improper test equipment is not covered under the warranty policy. While most steps do not require all of the equipment listed, the interactions of some adjustments may require that more complex adjustments be performed afterwards. Do not attempt to perform only a single step unless it is clearly isolated electrically from all other steps. Have all test equipment ready before beginning, and follow all of the steps in a section in the order presented.

Required Test Equipment

- RF Signal Generator with calibrated output level at 1 GHz
- AF Signal Generator
- Frequency Counter: ± 0.2 ppm accuracy at 1 GHz
- In-line Wattmeter with 5% accuracy at 1 GHz
- 50-ohm, 50-W RF Dummy Load (50 W mode) or 50-ohm, 100-W RF Dummy Load (100 W mode)
- 13.6V Regulated DC Power Supply with capable up to 15A (50 W mode) or 30A (100 W mode).
- AC Voltmeter
- DC Voltmeter
- UHF Sampling Coupler
- IBM® PC/Compatible Computer with Microsoft® Windows® 98 or later operating system
- CE60 Programming Software
- Vertex Standard FIF-10A (or FIF-12) + CT-104A USB Programming Interface
- Vertex Standard FRB-6 Tuning Interface Box and CT-159 Connection Cable

Alignment Preparation & Precautions

A 50-ohm RF Dummy load and in-line wattmeter must be connected to the main antenna jack in all procedures that call for transmission, except where specified otherwise. Correct alignment is not possible with an antenna.

After completing one step, read the following step to determine whether the same test equipment will be required. If not, remove the test equipment (except dummy load and wattmeter, if connected) before proceeding.

Correct alignment requires that the ambient temperature be the same as that of the transceiver and test equipment, and that this temperature be held constant between 20 °C and 30 °C (68 °F ~ 86 °F). When the transceiver is brought into the shop from hot or cold air, it should be allowed time to come to room temperature before alignment.

Whenever possible, alignments should be made with oscillator shields and circuit boards firmly affixed in place. Also, the test equipment must be thoroughly warmed up before beginning.

Note: Signal levels in dB referred to in this procedure are based on 0 dB μ EMF = 1.0 μ V.

Alignment

The Alignment Tool Outline

1. Install the CE60 (Programming Software) to your PC.
2. Execute the CE60 with the “/d” option (Dealer mode: type “ce60win.exe /d” [ENTER]).
3. You may adjust the following parameters from the computer.
 - RX Sensitivity
 - Squelch Sensitivity
 - TX Power
 - Maximum Deviation <Wide/Narrow>
 - Maximum Deviation <Wide/Narrow>
 - Sub-Audio (CTCSS/DCS) Deviation <Wide/Narrow>
 - Modulation Balance
 - Repeat Sensitivity
 - TX Power Down Detect
 - PLL Reference Frequency

RX Sensitivity

- ① Setup the test equipment as shown below.

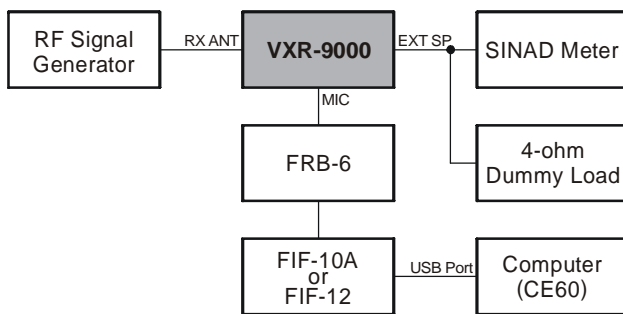

- ② Open the “Alignment” window, then click the *left* mouse button on the “Rx Tune” tab to move to the “Rx Tune” screen.
- ③ Click the *left* mouse button on the “Low Band Edge Frequency” box on the “RX BPF” field (highlighted in “pink”).
- ④ Set the RF Signal Generator output to the “Low Band Edge” Frequency, at a level of $-6 \text{ dB}\mu\text{V}$, $\pm 3.0 \text{ kHz}$ deviation with a 1 kHz audio tone.
- ⑤ Press the [Page Up]/[Page Down] key so that the SINAD meter reaches maximum deflection.
- ⑥ Repeat above steps at the other four points (box: frequencies).

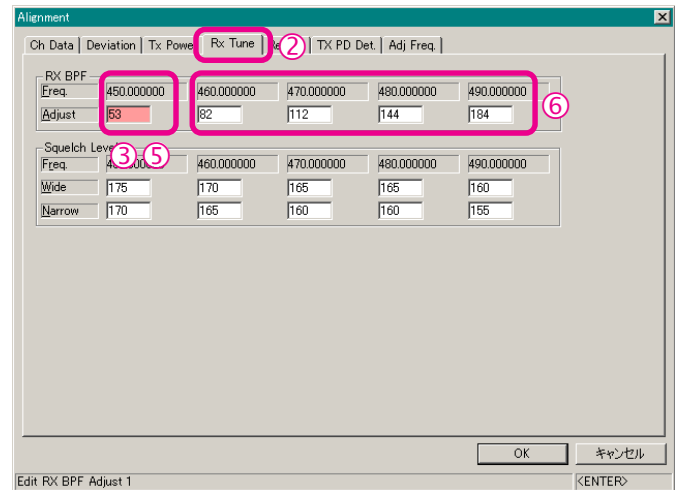

SQL Sensitivity

- Setup the test equipment as shown below.

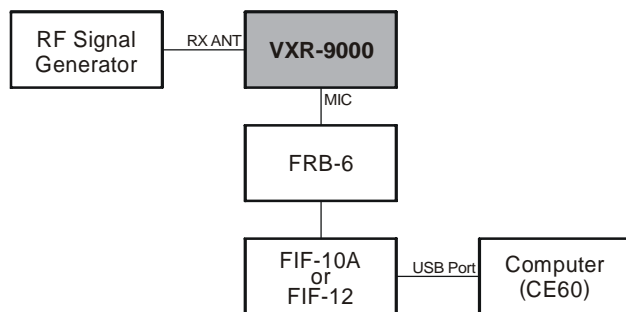

- Open the “Alignment” window, then click the *left* mouse button on the “Rx Tune” tab to move to the “Rx Tune” screen.
- Click the *left* mouse button on the “Wide” box on the “Low Band Edge Frequency” area of the “Squelch Level” field (highlighted in “pink”).
- Set the RF Signal Generator output to the “Low Band Edge” Frequency, at a level of $-3\text{ dB}\mu\text{V}$, $\pm 3.0\text{ kHz}$ deviation with a 1 kHz audio tone.
- Press the [Page Down] key until the squelch close, then press the [Page Up] key to the point where the squelch is just opened.
- Repeat above steps at the other four points (box: frequencies).

- Click the *left* mouse button on the “Narrow” box on the “Low Band Edge Frequency” area of the “Squelch Level” field (highlighted in “pink”).
- Set the RF Signal Generator output to the “Low Band Edge” Frequency, at a level of $-3\text{ dB}\mu\text{V}$, $\pm 1.5\text{ kHz}$ deviation with a 1 kHz audio tone.
- Press the [Page Down] key until the squelch close, then press the [Page Up] key to the point where the squelch is just opened.
- Repeat the above steps at the four points (box: frequencies).

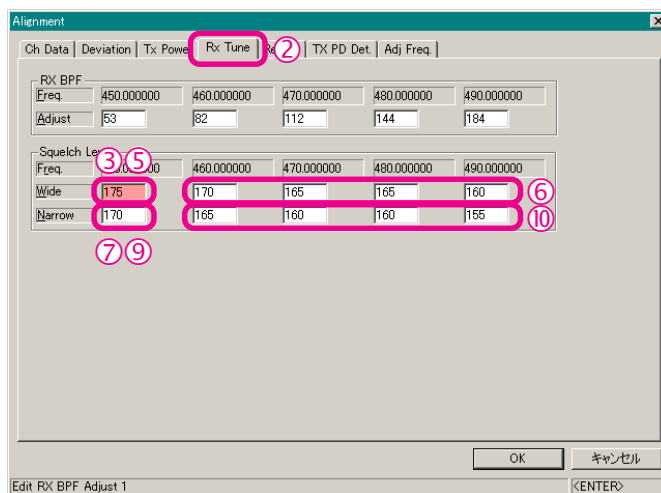

TX Power

- Setup the test equipment as shown below.

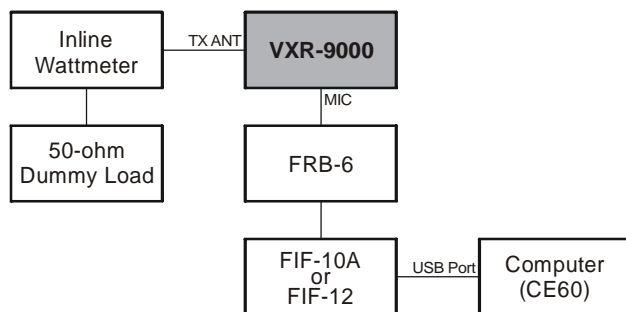

- Open the “Alignment” window, then click the *left* mouse button on the “Tx Power” tab to move to the “Tx Power” screen.
- Click the *left* mouse button on the “High” box on the “Low Band Edge Frequency” area of the “TX Power” field (highlighted in “pink”).
- Click the *left* mouse button on the “PTT On” button to activate the transmitter (the “PTT On” label is changed to “PTT Off”).
- Press the [Page Up]/[Page Down] key so that the Power Meter reading is 50 W.
- Click the *left* mouse button on the “PTT Off” button to disable the transmitter (the “PTT Off” label is returned to “PTT On”).

- Repeat the above steps at the “Mid” (25 W) and “Low” (10 W) boxes.
- Repeat the above steps at the 12 points (box: frequencies).

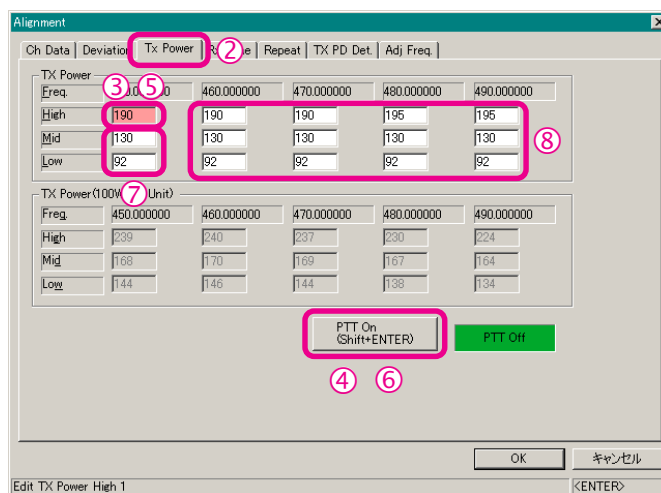

Note: When the optional 100 PA Unit is installed, perform this adjustment parameter in the “TX Power (100 W Unit)” field. In this case, adjust the “High” power to “100 W,” “Mid” power to “50 W,” and “Low” power to “25 W.”

Alignment

Maximum Deviation

- Setup the test equipment as shown below.

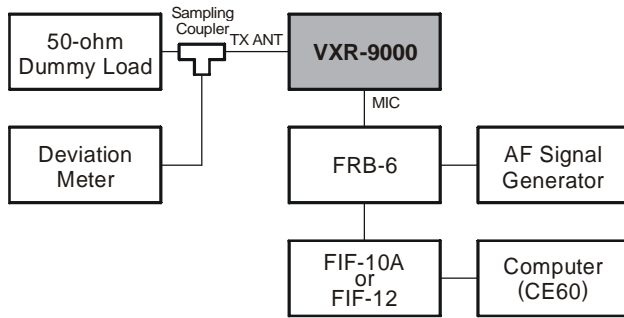

- Set the AF Signal Generator output to 35 mVrms at 1 kHz.
- Open the "Alignment" window, then click the *left* mouse button on the "Deviation" tab to move to the "Deviation" screen.
- Click the *left* mouse button on the "Wide" box on the "Low Band Edge Frequency" area of the "MAX Deviation (Audio)" field (highlighted in "pink").
- Click the *left* mouse button on the "PTT On" button to activate the transmitter (the "PTT On" label is changed to "PTT Off").
- Press the [Page Up]/[Page Down] key so that the Deviation Meter reading is 4.2 kHz \pm 0.2 kHz.

- Click the *left* mouse button on the "PTT Off" button to disable the transmitter (the "PTT Off" label is returned to "PTT On").
- Repeat the above steps at the "Narrow" box on the "Low Band Edge Frequency" area of the "MAX Deviation (Audio)" field (highlighted in "pink") so that the Deviation Meter reading is 2.1 kHz \pm 0.1 kHz.
- Repeat the above steps at the eight points (box: frequencies).

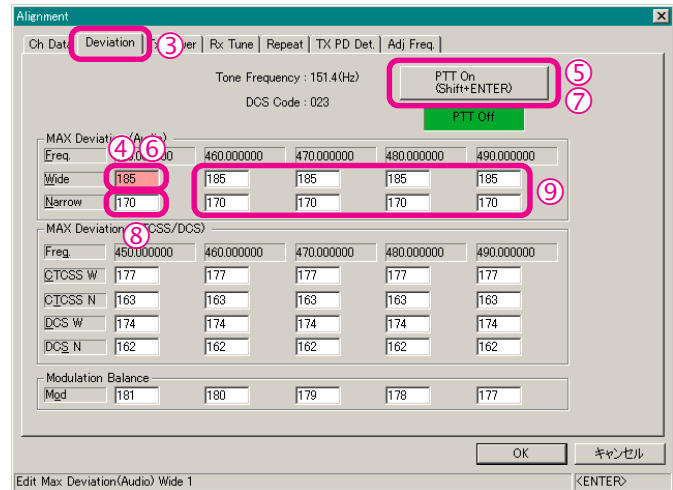

Sub-Audio (CTCSS) Deviation

- Setup the test equipment as shown below.

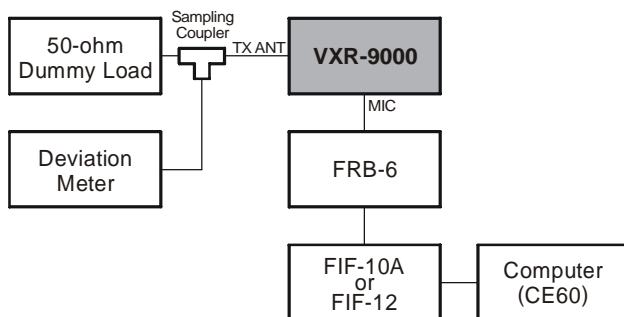

- Open the "Alignment" window, then click the *left* mouse button on the "Deviation" tab to move to the "Deviation" screen.
- Click the *left* mouse button on the "CTCSS W" box on the "Low Band Edge Frequency" area of the "MAX Deviation (CTCSS/DCS)" field (highlighted in "pink").
- Click the *left* mouse button on the "PTT On" button to activate the transmitter (the "PTT On" label is changed to "PTT Off").
- Press the [Page Up]/[Page Down] key so that the Deviation Meter reading is 0.75 kHz \pm 0.05 kHz.

- Click the *left* mouse button on the "PTT Off" button to disable the transmitter (the "PTT Off" label is returned to "PTT On").
- Repeat the above steps at the "CTCSS N" box on the "Low Band Edge Frequency" area of the "MAX Deviation (CTCSS/DCS)" field (highlighted in "pink") so that the Deviation Meter reading is 0.38 kHz \pm 0.02 kHz.
- Repeat the above steps at the eight points (box: frequencies).

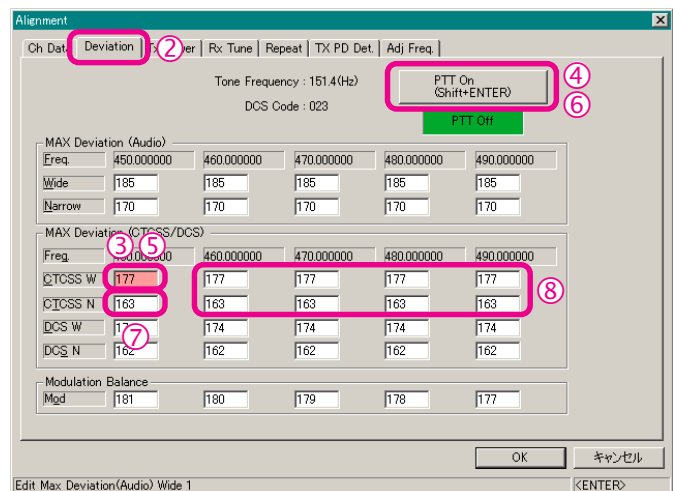

Sub-Audio (DCS) Deviation

- Setup the test equipment as shown below.

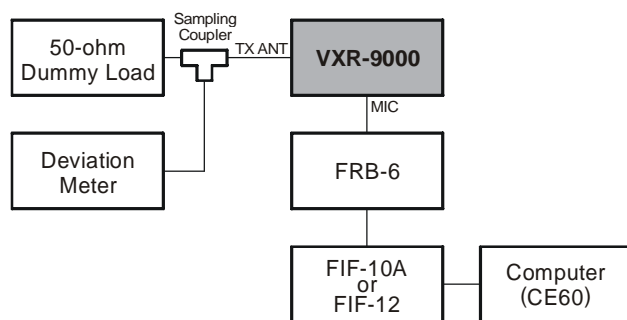

- Open the "Alignment" window, then click the *left* mouse button on the "Deviation" tab to move to the "Deviation" screen.
- Click the *left* mouse button on the "DCS W" box on the "Low Band Edge Frequency" area of the "MAX Deviation (CTCSS/DCS)" field (highlighted in "pink").
- Click the *left* mouse button on the "PTT On" button to activate the transmitter (the "PTT On" label is changed to "PTT Off").
- Press the [Page Up]/[Page Down] key so that the Deviation Meter reading is 0.75 kHz \pm 0.1 kHz.

- Click the *left* mouse button on the "PTT Off" button to disable the transmitter (the "PTT Off" label is returned to "PTT On").
- Repeat the above steps at the "DCS N" box on the "Low Band Edge Frequency" area of the "MAX Deviation (CTCSS/DCS)" field (highlighted in "pink") so that the Deviation Meter reading is 0.38 kHz \pm 0.08 kHz.
- Repeat the above steps at the eight points (box: frequencies).

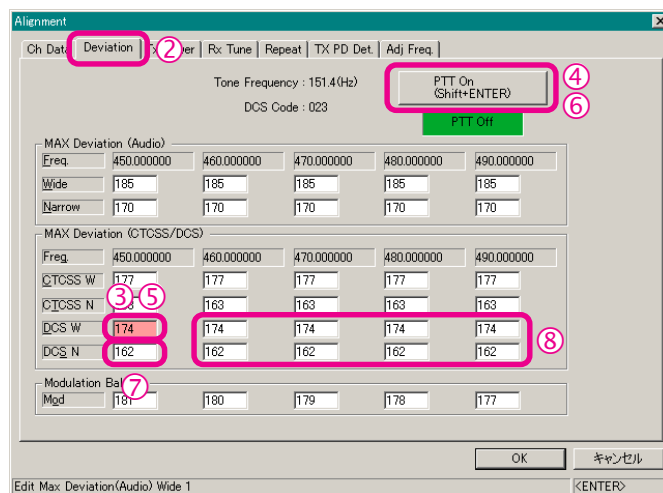

Modulation Balance

- Setup the test equipment as shown below.

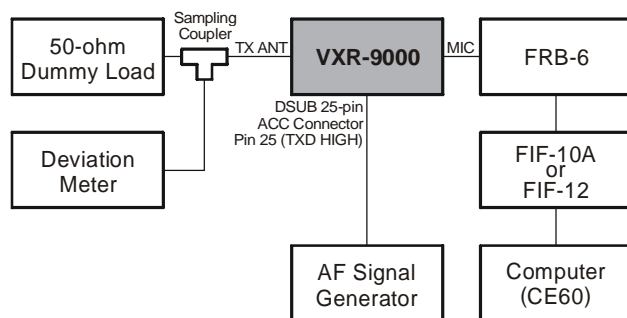

- Set the AF Signal Generator output to 500 mVp-p, 100 Hz square signal.
- Open the "Alignment" window, then click the *left* mouse button on the "Deviation" tab to move to the "Deviation" screen.
- Click the *left* mouse button on the "Mod" box on the "Low Band Edge Frequency" area of the "Modulation Balance" field (highlighted in "pink").
- Click the *left* mouse button on the "PTT On" button to activate the transmitter (the "PTT On" label is changed to "PTT Off").
- Press the [Page Up]/[Page Down] key so that the Oscilloscope shown 100 Hz square wave is obtained. See illustrations at the right.

- Click the *left* mouse button on the "PTT Off" button to disable the transmitter (the "PTT Off" label is returned to "PTT On").
- Repeat the above steps at the four points (box: frequencies).

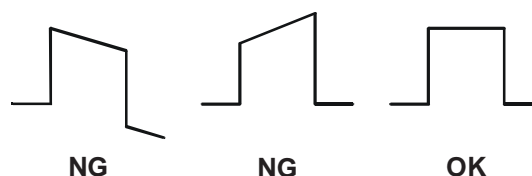
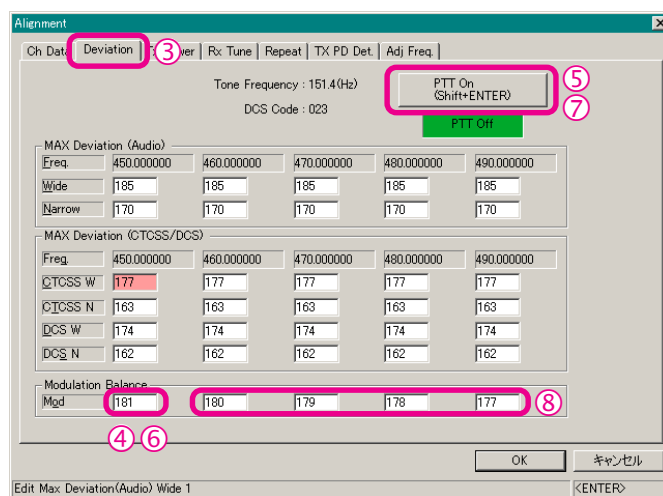

Alignment

Repeat Sensitivity

- Setup the test equipment as shown below.

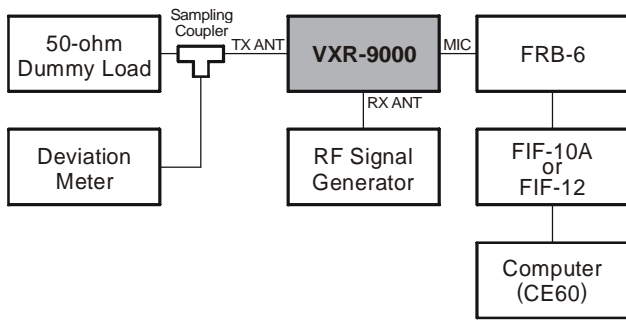

- Open the “Alignment” window, then click the *left* mouse button on the “Repeat” tab to move to the “Repeat” screen.
- Set the RF Signal Generator output to the “Repeat RX Frequency,” at a level of +40 dBμV, ±3.0 kHz deviation with a 1 kHz audio tone.
- Click the *left* mouse button on the “Repeat Sensitivity” box.
- Click the *left* mouse button on the “Repeat Sens. Enb” button to activate the transmitter (the “Repeat Sens. Enb” label is changed to “Repeat TX Off”).

- Press the [Page Up]/[Page Down] key so that the Deviation Meter reading is 3.0 kHz ±0.2 kHz.
- Click the *left* mouse button on the “Repeat TX Off” button to disable the transmitter (the “Repeat TX Off” label is returned to “Repeat Sens. Enb”).

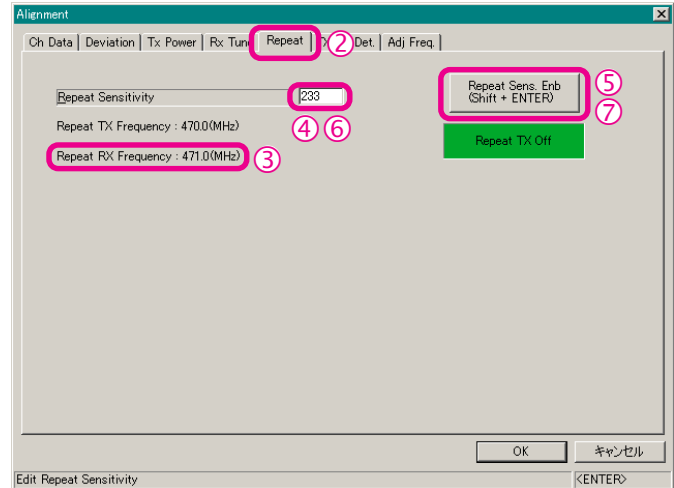

TX Power Down Detect

- Setup the test equipment as shown below.

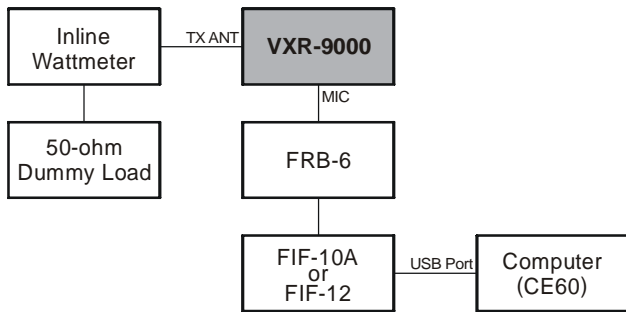

- Open the “Alignment” window, then click the *left* mouse button on the “TX PD Det.” tab to move to the “TX PD Det.” screen.
- Click the *left* mouse button on the “Adjust” box on the “Low Band Edge Frequency” area of the “Tx Power Low Temporary ADJ” field (highlighted in “pink”).
- Click the *left* mouse button on the “TX PD Det. Enb” button to activate the transmitter (the “TX PD Det. Enb” label is changed to “PTT Off”).
- Press the [Page Up]/[Page Down] key so that the Power Meter reading is 5 W.
- Click the *left* mouse button on the “READ” button to save the “TX Power Down Detect” data.

- Click the *left* mouse button on the “PTT Off” button to disable the transmitter (the “PTT Off” label is returned to “TX PD Det. Enb”).
- Repeat the above steps at the four points (box: frequencies).

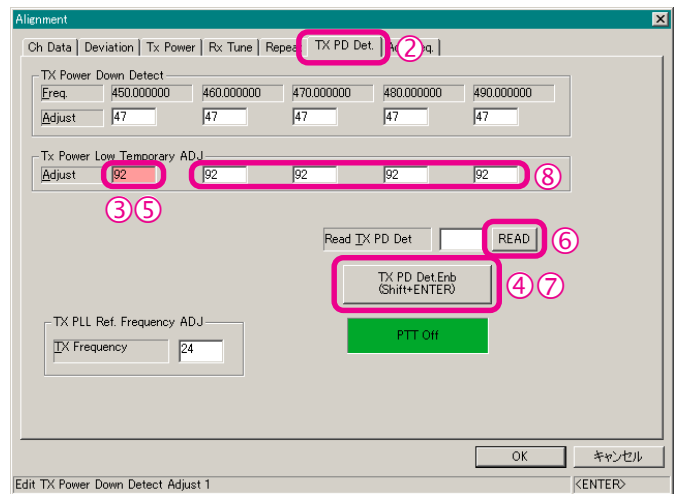

PLL Reference Frequency

Important Note: (1) Do not this adjustment unless you have a high-performance frequency counter. (2) This adjustment needs to add a “Chip Resistor” on to the Main Unit. For further details contact to Vertex Standard.

① Setup the test equipment as shown below.

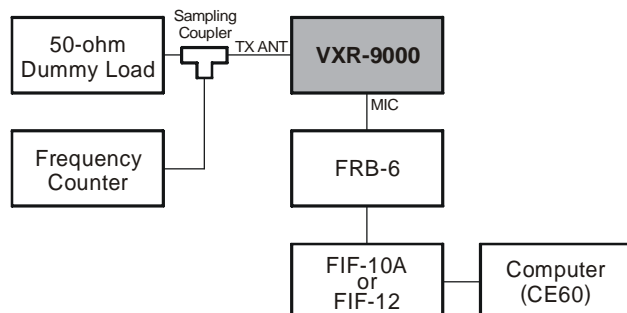

② Open the “Alignment” window, then click the *left* mouse button on the “TX PD Det.” tab to move to the “TX PD Det.” screen.

③ Click the *left* mouse button on the “TX Frequency” box (highlighted in “pink”).

④ Click the *left* mouse button on the “TX PD Det. Enb” button to activate the transmitter (the “TX PD Det. Enb” label is changed to “PTT Off”).

⑤ Press the [Page Up]/[Page Down] key so that the Frequency Counter reading is “Low Band Edge Frequency” ± 100 Hz.

⑥ Click the *left* mouse button on the “PTT Off” button to disable the transmitter (the “PTT Off” label is returned to “TX PD Det. Enb”).

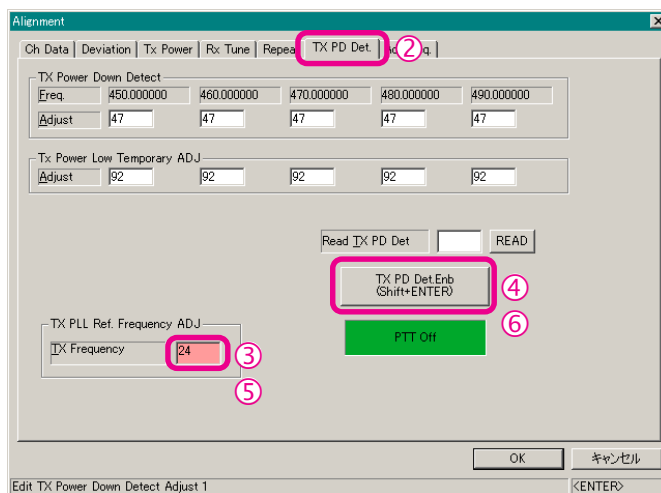

Alignment

Note:

AC044U MAIN-UNIT for UHF/D-BAND (1001 - 2999)

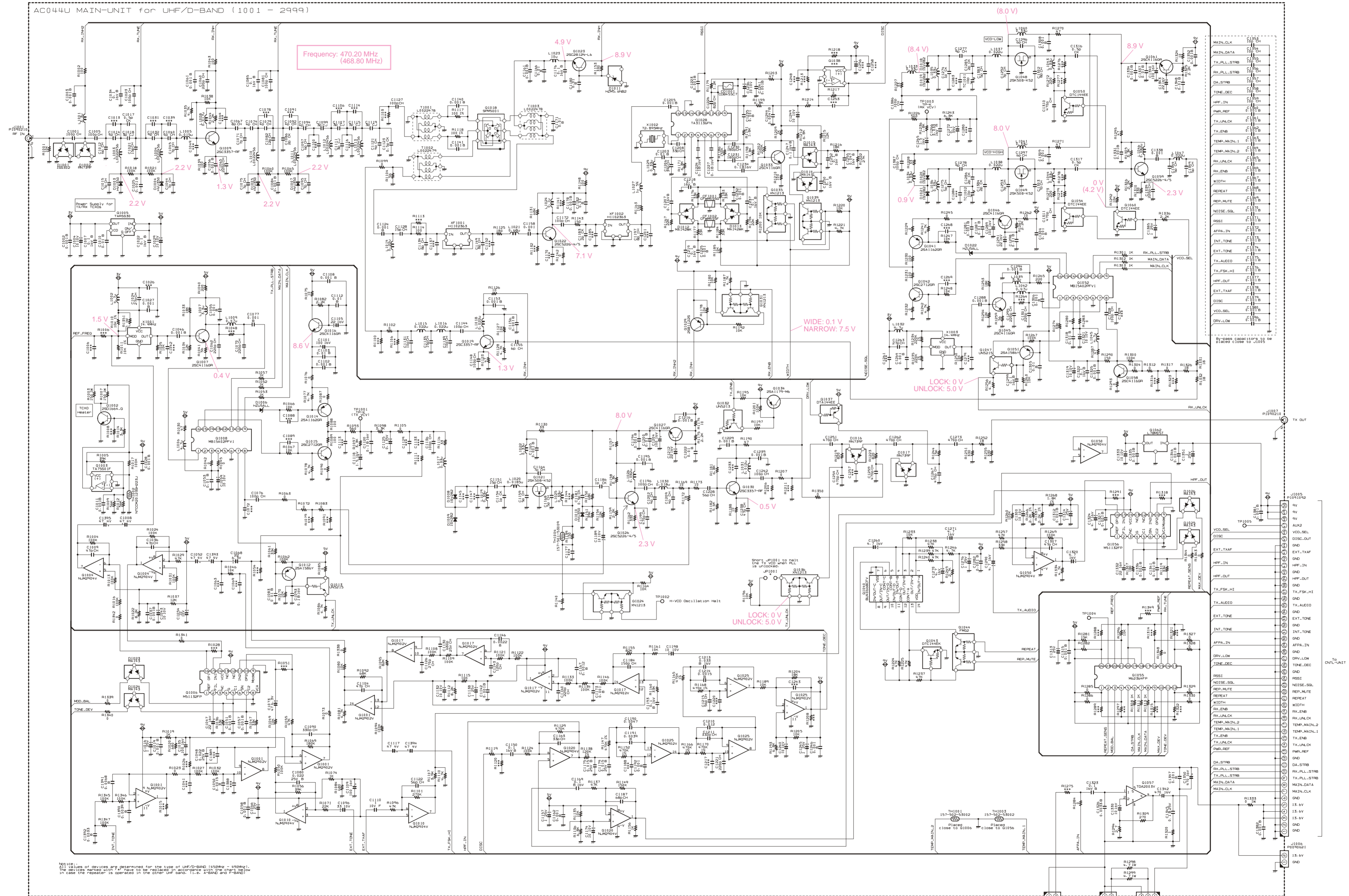

MAIN_CLK	U1001
MAIN_DATA	U1001
TX_PLL_STDB	U1001
RX_PLL_STDB	U1001
DA_STDB	U1001
TX_ENB	U1001
RX_ENB	U1001
TEMP_MAIN_1	U1001
TEMP_MAIN_2	U1001
REP_UNLOCK	U1001
RX_UNLOCK	U1001
REP_MUTE	U1001
NOISE_SOL	U1001
RRS1	U1001
AFRA_IN	U1001
INT_TONE	U1001
EXT_TONE	U1001
TX_AUDIO	U1001
TX_FSK_H1	U1001
HPF_OUT	U1001
EXT_TXAF	U1001
DISC	U1001
VCO_SEL	U1001
DRV_LOW	U1001
TONE_DEC	U1001
RRS1	U1001
NOISE_SOL	U1001
REP_MUTE	U1001
REPEAT	U1001
REP_UNLOCK	U1001
RX_UNLOCK	U1001
TEMP_MAIN_1	U1001
TEMP_MAIN_2	U1001
TX_ENB	U1001
TX_UNLOCK	U1001
DA_STDB	U1001
RX_PLL_STDB	U1001
TX_PLL_STDB	U1001
MAIN_DATA	U1001
MAIN_CLK	U1001

To external speaker
To external speaker

MAIN Unit (Lot. 1~2)

Note

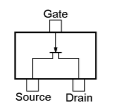
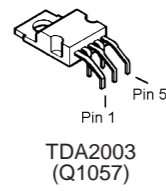
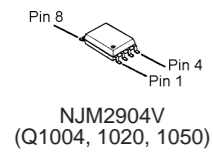
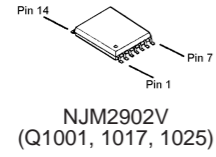
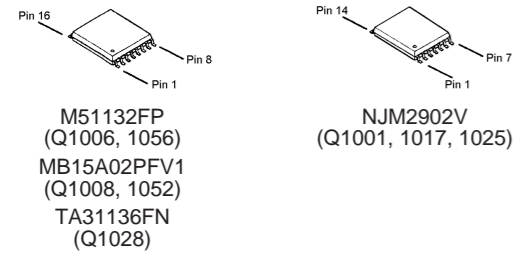

2SK508 (K52) (Q1021, 1048, 1049)

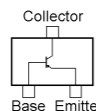

2SA1586Y (SY) (Q1051)

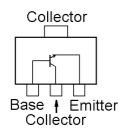

2SC3357 (RK) (Q1009, 1030)

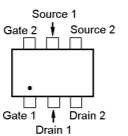

SPM5001 (Q1018)

2SC4116GR (LG) (Q1007, 1033, 1045, 1046, 1061)

2SC5226 (R22) (Q1022, 1026, 1059)

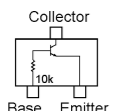

UN5215 (8E) (Q1047)

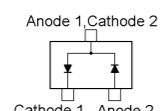

1SS302 (C3) (D1001)

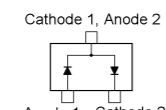

MA143 (MC) (D1014, 1015, 1023, 1024, 1025, 1026)

RN739F (5F) (D1002, 1016, 1017)

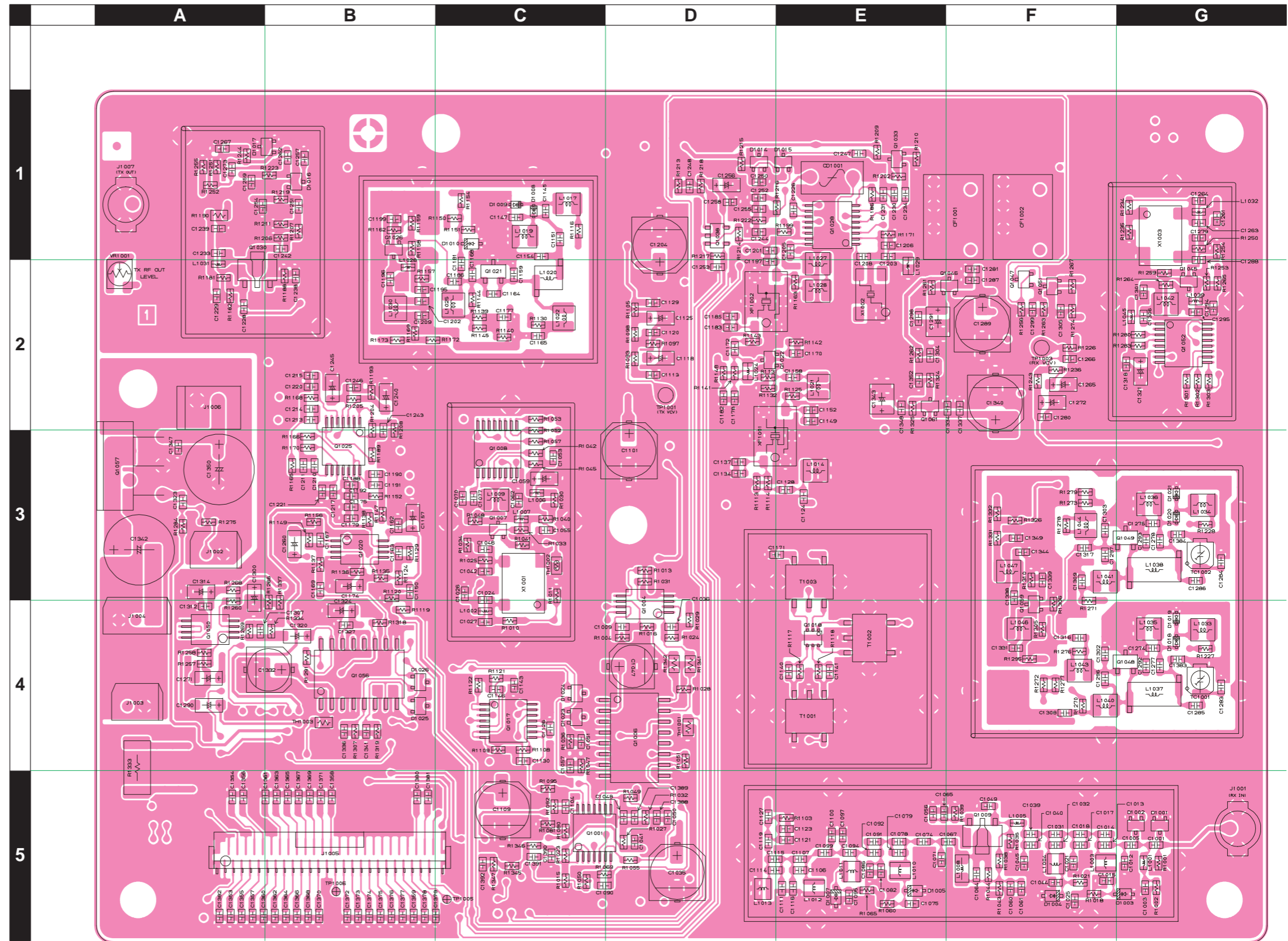

MAIN Unit (Lot. 1~2)

Parts Layout (Side B)

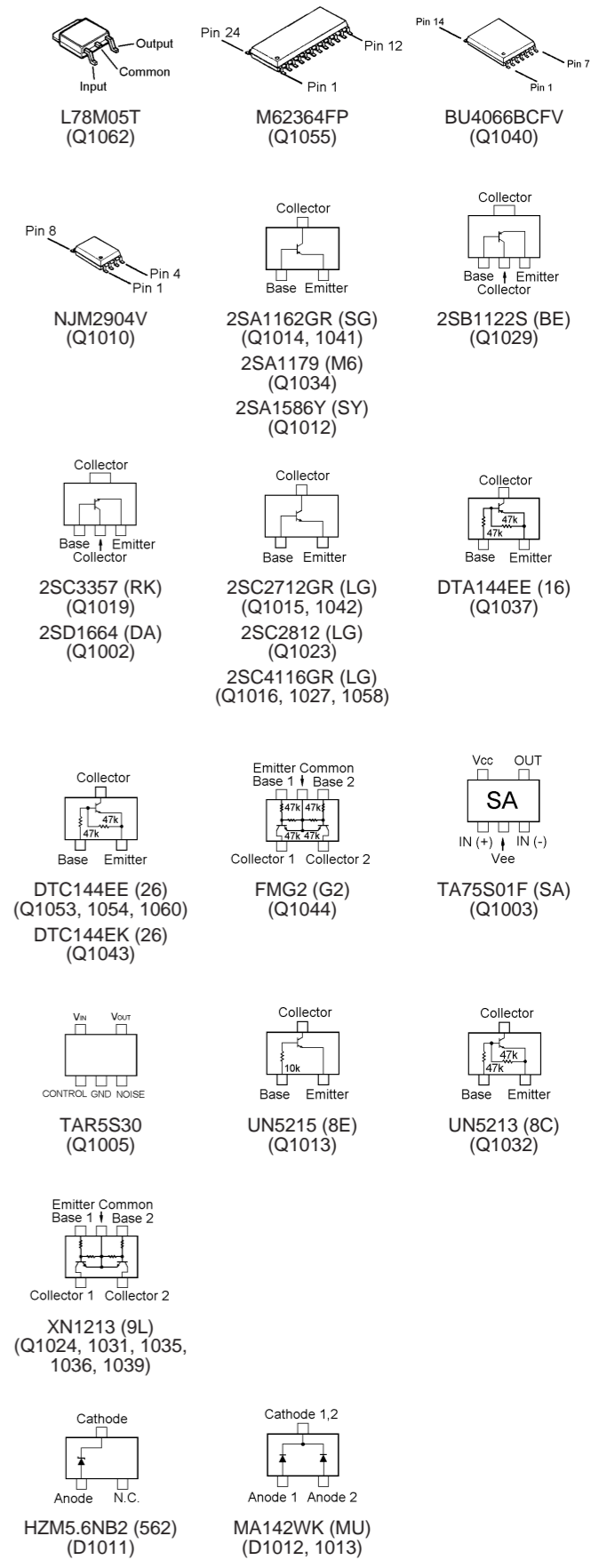
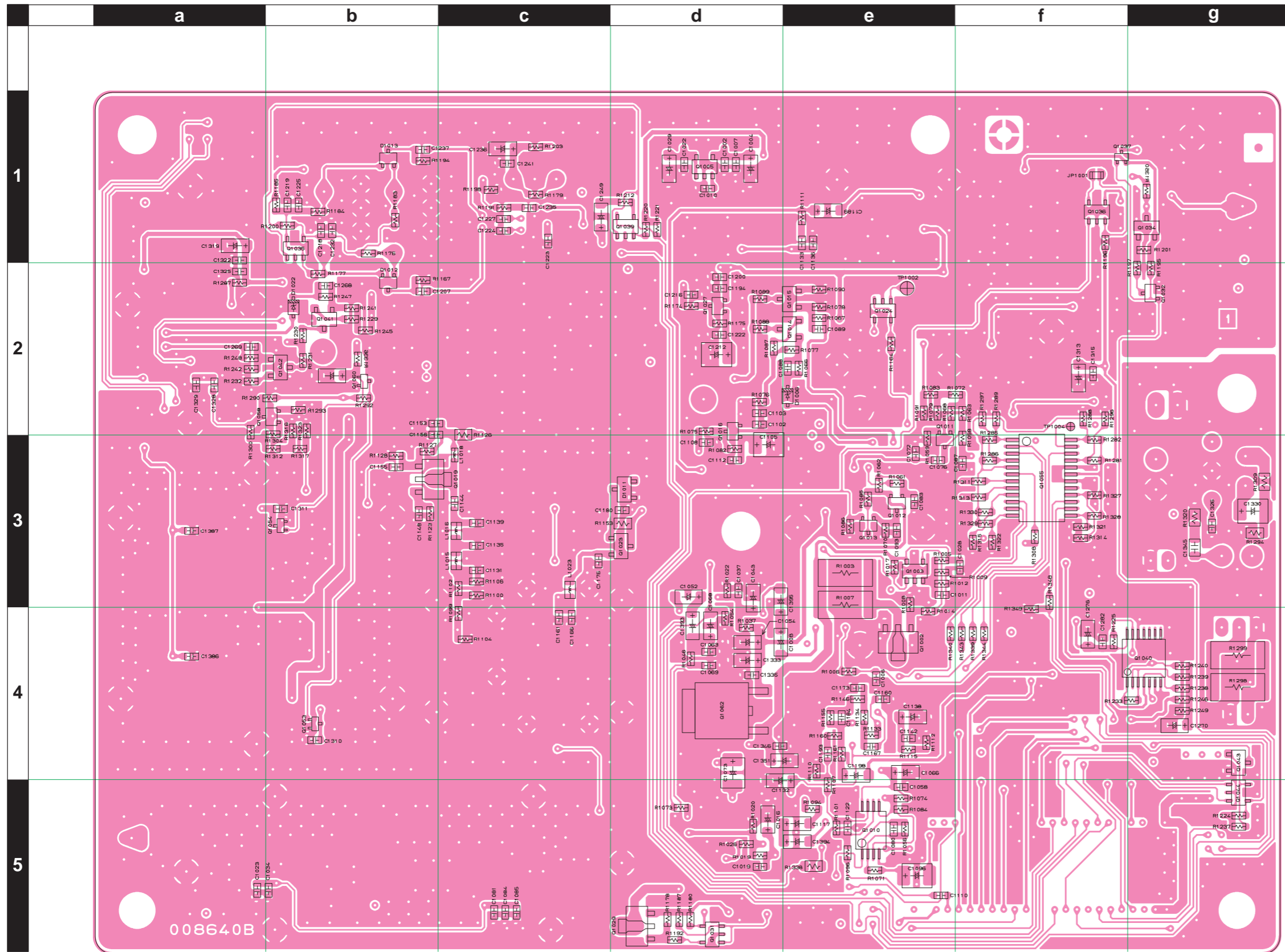

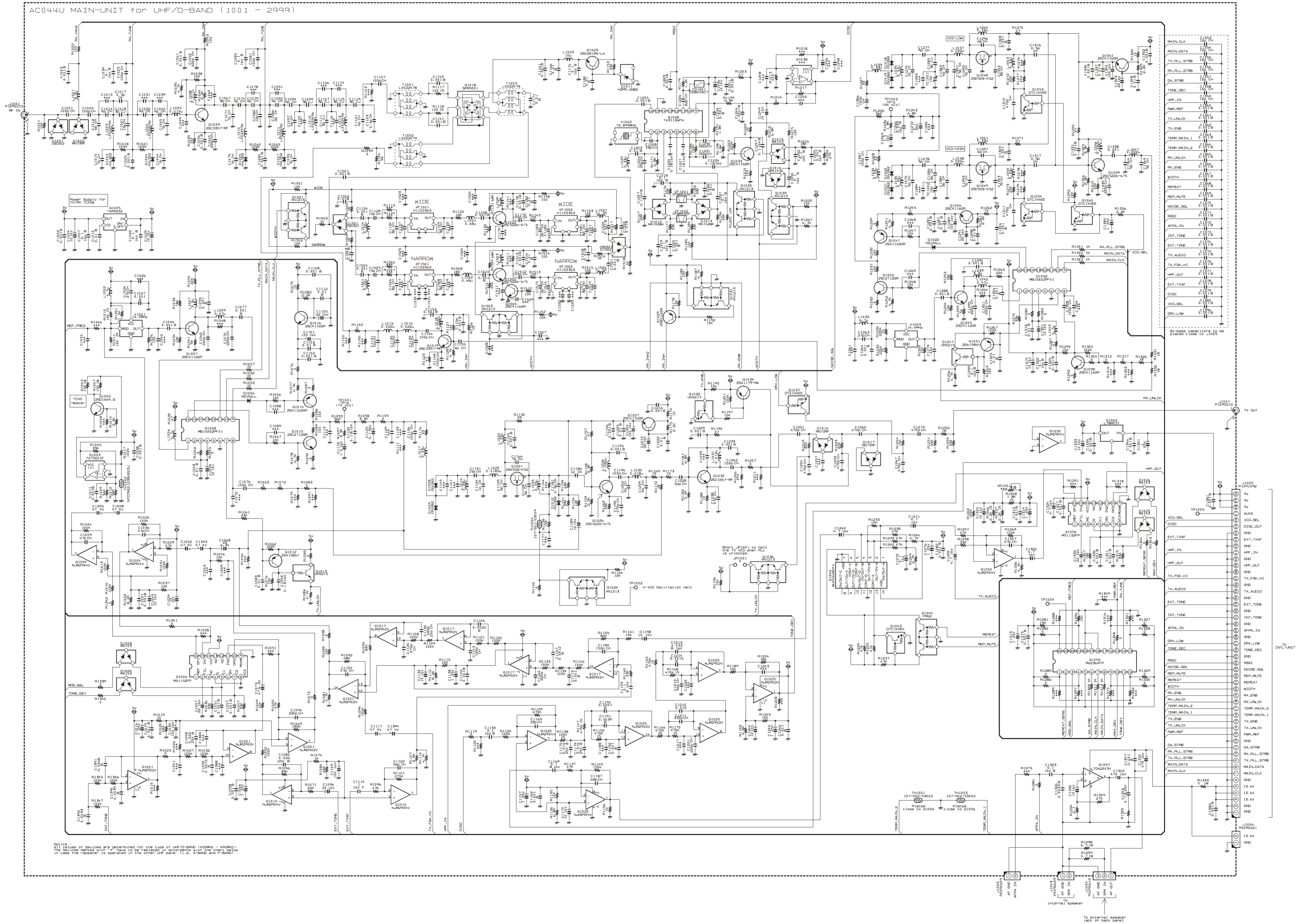

MAIN Unit (Lot. 3~24)

Note

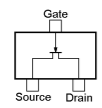
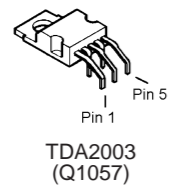
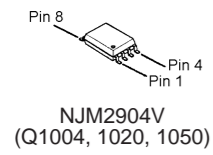
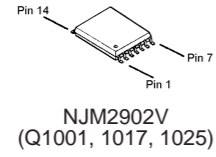
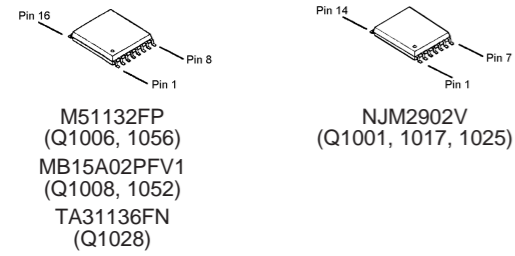

2SK508 (K52) (Q1021, 1048, 1049)

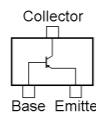

2SA1586Y (SY) (Q1051)

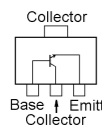

2SC3357 (RK) (Q1009, 1030)

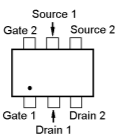

SPM5001 (Q1018)

2SC4116GR (LG) (Q1007, 1033, 1045, 1046, 1061)

2SC5226 (R22) (Q1022, 1026, 1059)

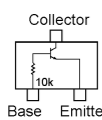

UN5215 (8E) (Q1047)

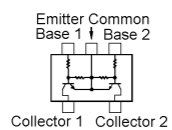

XN1213 (9L) (Q1503)

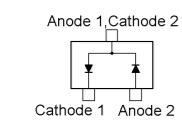

1SS302 (C3) (D1001)

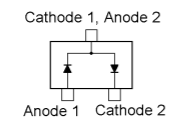

MA143 (MC) (D1014, 1015, 1023, 1024, 1025, 1026)
RN739F (5F) (D1002, 1016, 1017)

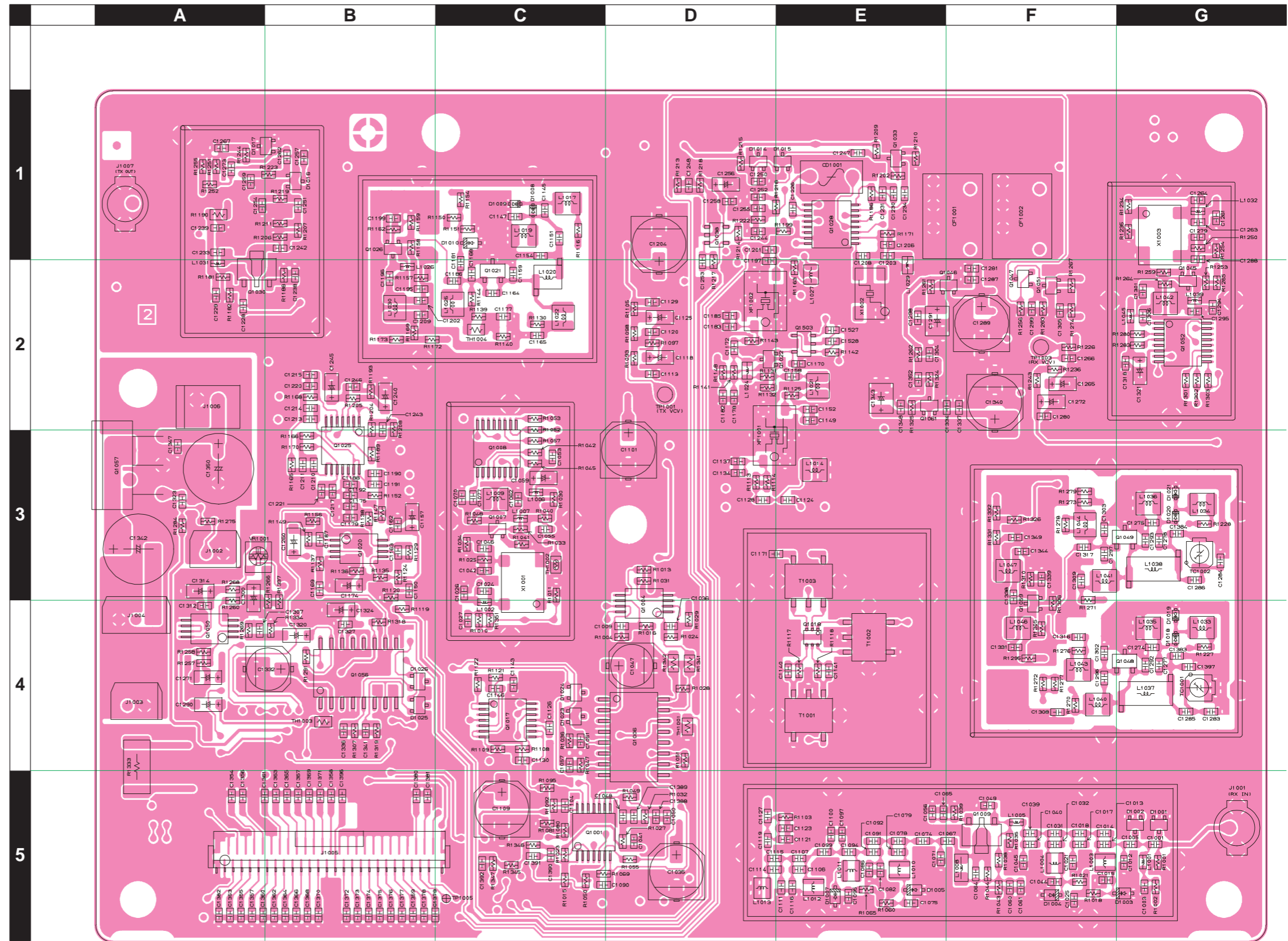

MAIN Unit (Lot. 3~24)

Parts Layout (Side B)

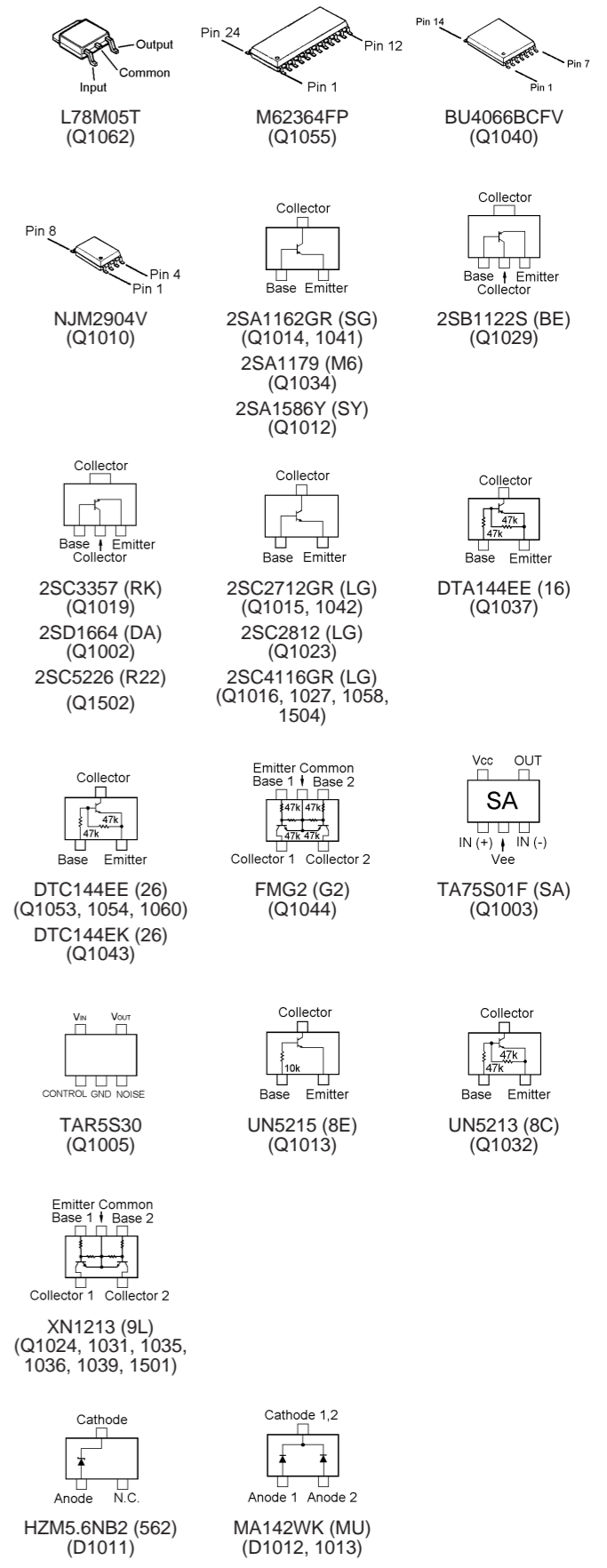
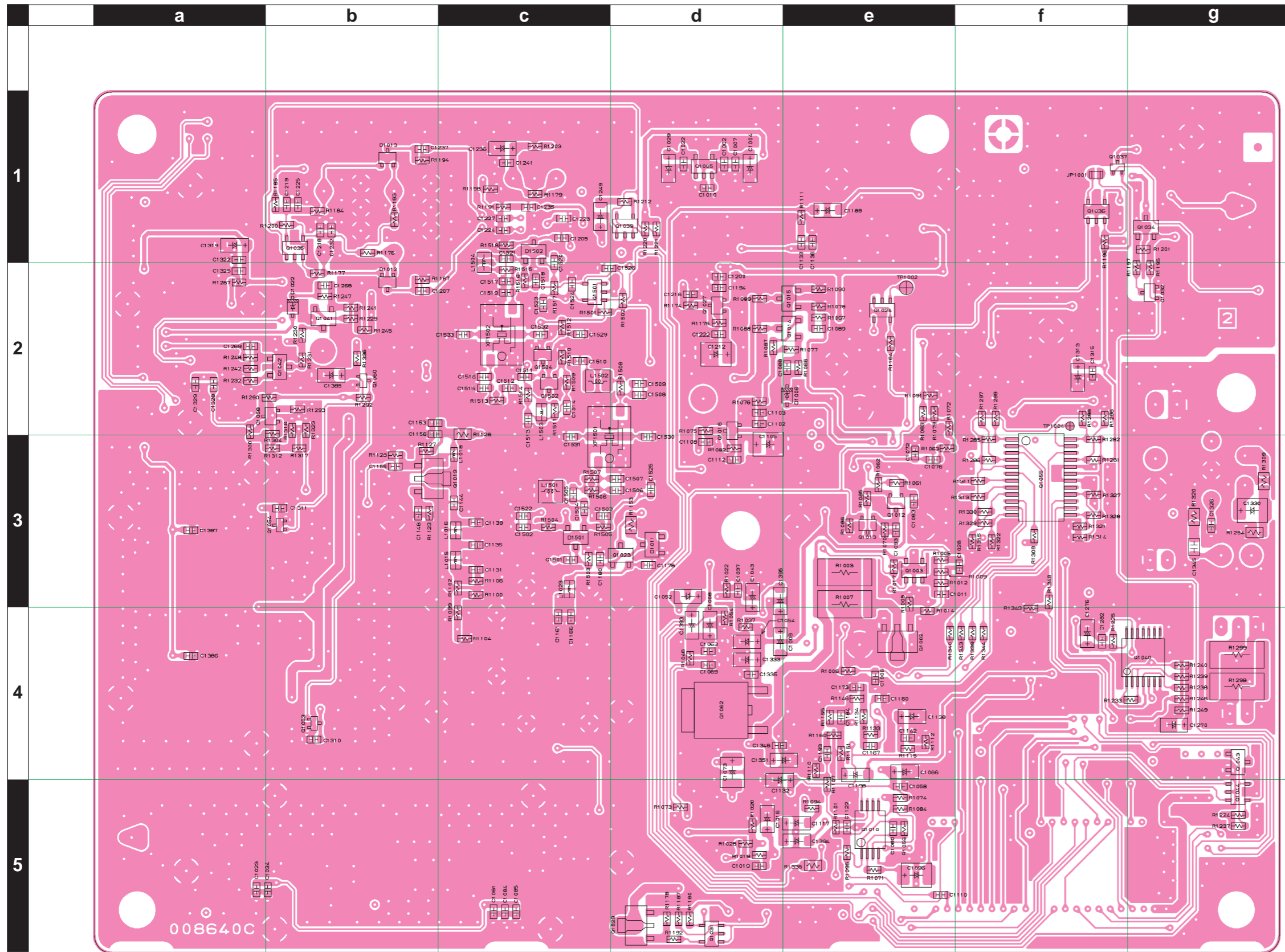

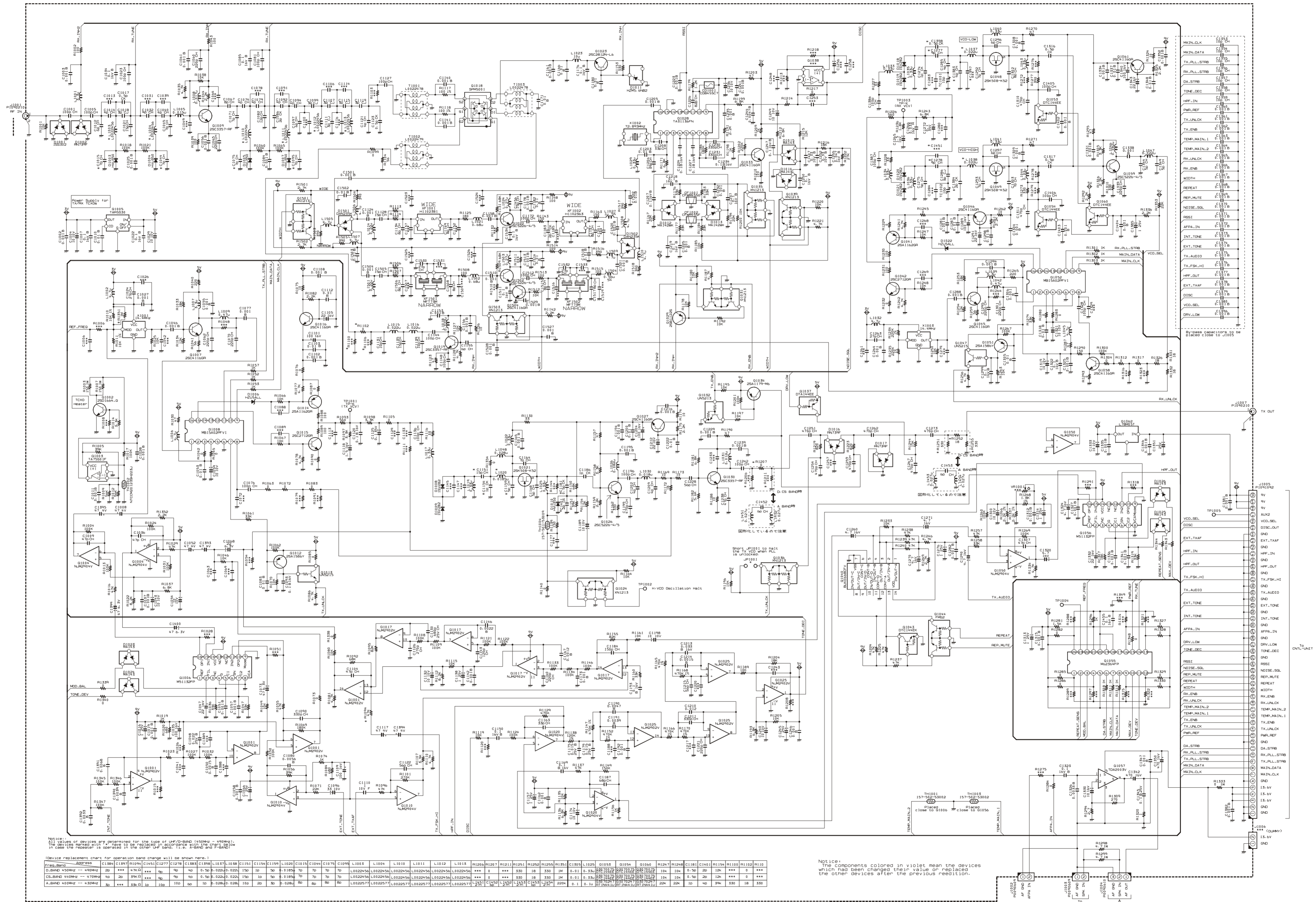

MAIN Unit (Lot. 25~)

Note

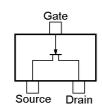
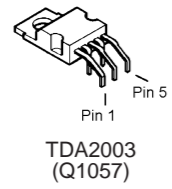
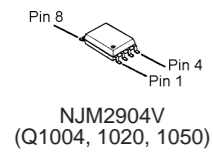
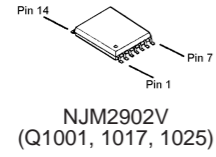
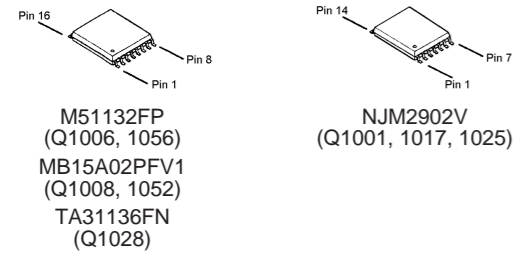

2SK508 (K52) (Q1021, 1048, 1049)

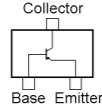

2SA1586Y (SY) (Q1051)

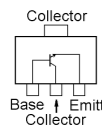

2SC3357 (RK) (Q1009, 1030)

2SC4116GR (LG) (Q1007, 1033, 1045, 1046, 1061)

2SC5226 (R22) (Q1022, 1026, 1059)

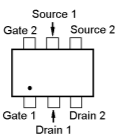

SPM5001 (Q1018)

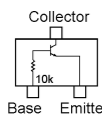

UN5215 (8E) (Q1047)

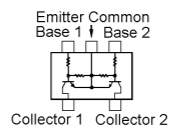

XN1213 (9L) (Q1503)

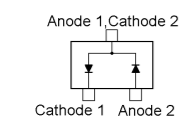

1SS302 (C3) (D1001)

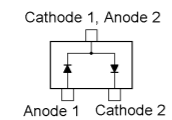

MA143 (MC) (D1014, 1015, 1023, 1024, 1025, 1026)
RN739F (5F) (D1002, 1016, 1017)

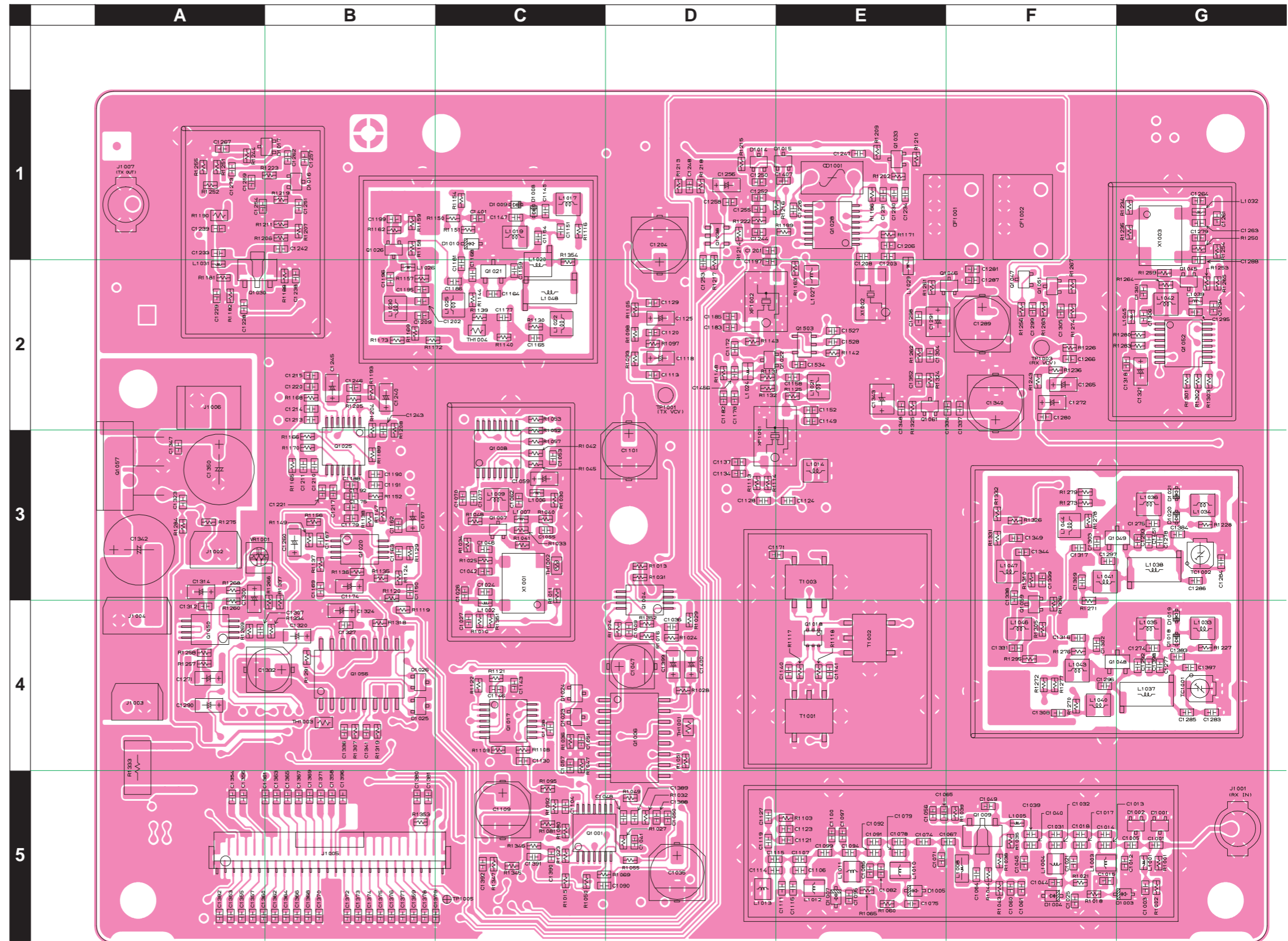

MAIN Unit (Lot. 25~)

Parts Layout (Side B)

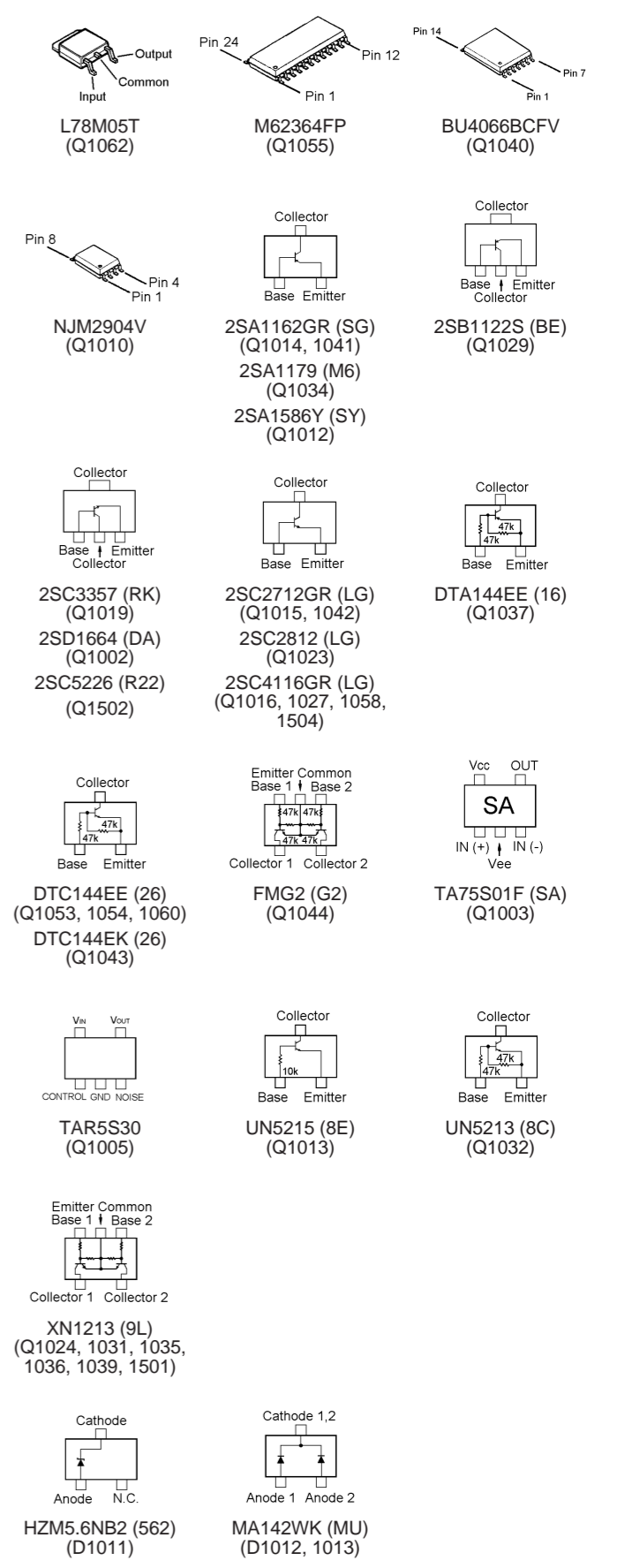
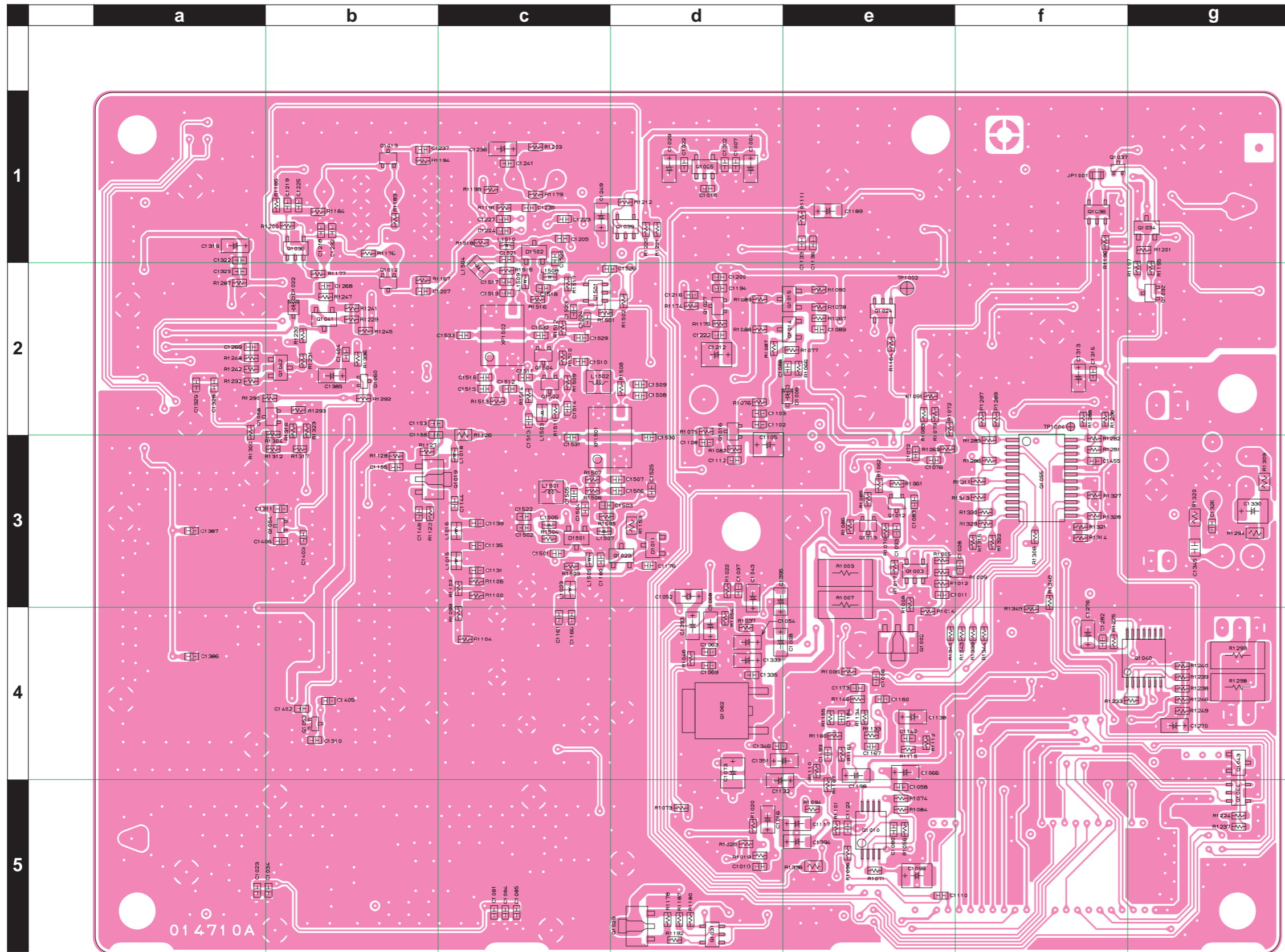

REF	DESCRIPTION	VALUE	V/W	TOL.	MFR'S DESIG	VXSTD P/N	VERS.	LOT	SIDE	LAY ADR
PCB with Components						CS2132704	DST: USA	VER. D		
						CS2132705	DST: EXP	VER. D		
						CS2132706	DST: AUS	VER. D		
						CS2132707	DST: USA	VER. A		
						CS2132708	DST: EXP	VER. A		
C 1001	CHIP CAP.	100pF	50V	CH	GRM1882C1H101JA01D	K22174235	VER. A VER. D	1-	A	G4
C 1002	CHIP CAP.	0.001uF	50V	B	GRM188B11H102KA01D	K22174821		1-	B	d1
C 1003	CHIP CAP.	0.001uF	50V	B	GRM188B11H102KA01D	K22174821		1-	A	G5
C 1004	CHIP TA.CAP.	10uF	10V		TEESVA1A106M8R	K78100028		1-	B	d1
C 1005	CHIP CAP.	100pF	50V	CH	GRM1882C1H101JA01D	K22174235		1-	A	G4
C 1007	CHIP CAP.	0.1uF	16V	B	GRM188B11C104KA01D	K22124805		1-	B	d1
C 1008	CHIP TA.CAP.	47uF	4V		SK7-0G476M-RA	K78060048		1-	B	d3
C 1009	CHIP CAP.	47pF	50V	CH	GRM1882C1H470JA01D	K22174227		1-	A	D3
C 1010	CHIP CAP.	0.01uF	50V	B	GRM188B11H103KA01D	K22174823		1-	B	d1
C 1011	CHIP CAP.	0.001uF	50V	B	GRM188B11H102KA01D	K22174821		1-	B	e3
C 1012	CHIP CAP.	6pF	50V	CH	GRM1882C1H6R0DZ01D	K22174207	1-	A	G4	
C 1014	CHIP CAP.	4pF	50V	CH	GRM1882C1H4R0CZ01D	K22174205	1-	A	F4	
C 1015	CHIP CAP.	7pF	50V	CH	GRM1882C1H7R0DZ01D	K22174208	1-20	A	F5	
C 1015	CHIP CAP.	8pF	50V	CH	GRM1882C1H8R0CZ01D	K22174246	VER. A 21-	A	F5	
C 1015	CHIP CAP.	7pF	50V	CH	GRM1882C1H7R0DZ01D	K22174208	VER. D 21-	A	F5	
C 1016	CHIP TA.CAP.	1uF	25V		TEESVA1E105M8R	K78140013	1-	B	d4	
C 1017	CHIP CAP.	0.5pF	50V	CK	GRM1884C1HR50CZ01D	K22174201	1-	A	F4	
C 1018	CHIP CAP.	3pF	50V	CJ	GRM1883C1H3R0CZ01D	K22174204	1-	A	F4	
C 1019	CHIP CAP.	0.001uF	50V	B	GRM188B11H102KA01D	K22174821	1-	B	d4	
C 1021	CHIP CAP.	15pF	50V	CH	GRM1882C1H150JA01D	K22174215	1-	A	F4	
C 1022	CHIP CAP.	0.1uF	16V	B	GRM188B11C104KA01D	K22124805	1-	B	d1	
C 1023	CHIP CAP.	100pF	50V	CH	GRM1882C1H101JA01D	K22174235	1-	B	a5	
C 1024	CHIP CAP.	27pF	50V	CH	GRM1882C1H270JA01D	K22174221	1-	A	C3	
C 1025	CHIP CAP.	0.001uF	50V	B	GRM188B11H102KA01D	K22174821	1-	A	F5	
C 1027	CHIP CAP.	0.001uF	50V	B	GRM188B11H102KA01D	K22174821	1-	A	C3	
C 1028	CHIP CAP.	0.001uF	50V	B	GRM188B11H102KA01D	K22174821	1-	B	f3	
C 1029	CHIP TA.CAP.	10uF	10V		TEESVA1A106M8R	K78100028	1-	B	d1	
C 1032	CHIP CAP.	4pF	50V	CH	GRM1882C1H4R0CZ01D	K22174205	1-	A	F4	
C 1034	CHIP CAP.	0.1uF	16V	B	GRM188B11C104KA01D	K22124805	1-	B	b5	
C 1035	AL.ELECTRO.CAP.	100uF	16V		EEE1CA101WP	K48120012	1-	A	D4	
C 1036	CHIP CAP.	47pF	50V	CH	GRM1882C1H470JA01D	K22174227	1-	A	D3	
C 1037	CHIP CAP.	0.001uF	50V	B	GRM188B11H102KA01D	K22174821	1-	B	d3	
C 1040	CHIP CAP.	4pF	50V	CH	GRM1882C1H4R0CZ01D	K22174205	1-	A	F4	
C 1043	CHIP TA.CAP.	10uF	10V		TEESVA1A106M8R	K78100028	1-	B	d3	
C 1044	CHIP CAP.	7pF	50V	CH	GRM1882C1H7R0DZ01D	K22174208	1-20	A	F5	
C 1044	CHIP CAP.	8pF	50V	CH	GRM1882C1H8R0CZ01D	K22174246	VER. A 21-	A	F5	
C 1044	CHIP CAP.	7pF	50V	CH	GRM1882C1H7R0DZ01D	K22174208	VER. D 21-	A	F5	
C 1045	CHIP CAP.	7pF	50V	CH	GRM1882C1H7R0DZ01D	K22174208	1-	A	F4	
C 1046	CHIP CAP.	0.001uF	50V	B	GRM188B11H102KA01D	K22174821	1-	A	C3	
C 1047	AL.ELECTRO.CAP.	22uF	16V		ECEV1CA220SR	K48120002	1-25	A	D3	
C 1047	AL.ELECTRO.CAP.	22uF	16V		EEE1CA220SR	K48120024	26-	A	D3	
C 1048	CHIP CAP.	0.022uF	25V	B	GRM39B223K25PT	K22144807	1-47	A	D4	
C 1048	CHIP CAP.	0.022uF	50V	B	GRM188B11H223KA01D	K22174839	48-	A	D4	
C 1050	CHIP CAP.	0.0015uF	50V	B	GRM188B11H152KA01D	K22174827	1-	A	D4	
C 1051	CHIP CAP.	0.001uF	50V	B	GRM188B11H102KA01D	K22174821	1-	A	C4	
C 1052	CHIP TA.CAP.	47uF	4V		SK7-0G476M-RA	K78060048	1-	B	d3	
C 1053	CHIP CAP.	0.01uF	50V	B	GRM188B11H103KA01D	K22174823	1-	A	C2	
C 1054	CHIP TA.CAP.	10uF	10V		TEESVA1A106M8R	K78100028	1-	B	d3	
C 1055	CHIP CAP.	0.001uF	50V	B	GRM188B11H102KA01D	K22174821	1-	A	C2	
C 1056	CHIP CAP.	0.001uF	50V	B	GRM188B11H102KA01D	K22174821	1-	A	E4	
C 1057	CHIP CAP.	0.001uF	50V	B	GRM188B11H102KA01D	K22174821	1-	A	C4	
C 1058	CHIP CAP.	0.001uF	50V	B	GRM188B11H102KA01D	K22174821	1-	B	e4	
C 1059	CHIP TA.CAP.	10uF	10V		TEESVA1A106M8R	K78100028	1-	A	C2	
C 1060	CHIP CAP.	220pF	50V	CH	GRM1882C1H221JA01D	K22174243	1-	A	F5	
C 1061	CHIP CAP.	0.001uF	50V	B	GRM188B11H102KA01D	K22174821	1-	A	F5	
C 1062	CHIP CAP.	220pF	50V	CH	GRM1882C1H221JA01D	K22174243	1-	A	C2	
C 1065	CHIP CAP.	220pF	50V	CH	GRM1882C1H221JA01D	K22174243	1-	A	E4	
C 1066	CHIP TA.CAP.	1uF	25V		TEESVA1E105M8R	K78140013	1-	B	e4	
C 1067	CHIP CAP.	8pF	50V	CH	GRM1882C1H8R0DZ01D	K22174209	1-	A	F4	
C 1068	CHIP TA.CAP.	22uF	6.3V		TEESVA0J226M8R	K78080047	1-	B	d3	
C 1070	CHIP CAP.	220pF	50V	CH	GRM1882C1H221JA01D	K22174243	1-	A	C2	
C 1071	CHIP CAP.	7pF	50V	CH	GRM1882C1H7R0DZ01D	K22174208	1-	A	E4	
C 1073	CHIP TA.CAP.	47uF	6.3V		TEESVB20J476M8R	K78080048	1-	B	d4	
C 1074	CHIP CAP.	4pF	50V	CH	GRM1882C1H4R0CZ01D	K22174205	1-	A	E4	
C 1075	CHIP CAP.	7pF	50V	CH	GRM1882C1H7R0DZ01D	K22174208	1-20	A	E5	
C 1075	CHIP CAP.	8pF	50V	CH	GRM1882C1H8R0CZ01D	K22174246	VER. A 21-	A	E5	
C 1075	CHIP CAP.	7pF	50V	CH	GRM1882C1H7R0DZ01D	K22174208	VER. D 21-	A	E5	
C 1076	CHIP CAP.	100pF	50V	CH	GRM1882C1H101JA01D	K22174235	1-	B	e2	

MAIN Unit

Parts List

REF	DESCRIPTION	VALUE	V/W	TOL.	MFR'S DESIG	VXSTD P/N	VERS.	LOT	SIDE	LAY ADR
C 1077	CHIP CAP.	0.001uF	50V	B	GRM188B11H102KA01D	K22174821		1-	A	C2
C 1079	CHIP CAP.	4pF	50V	CH	GRM1882C1H4R0CZ01D	K22174205		1-	A	E4
C 1080	CHIP CAP.	0.0056uF	50V	B	GRM188B11H562KA01D	K22174818		1-	B	e4
C 1081	CHIP CAP.	100pF	50V	CH	GRM1882C1H101JA01D	K22174235		1-	B	c5
C 1082	CHIP CAP.	12pF	50V	CH	GRM1882C1H120JA01D	K22174213		1-	A	E4
C 1083	CHIP CAP.	0.01uF	50V	B	GRM188B11H103KA01D	K22174823		1-	B	e2
C 1084	CHIP CAP.	0.001uF	50V	B	GRM188B11H102KA01D	K22174821		1-	B	c5
C 1085	CHIP CAP.	0.1uF	16V	B	GRM188B11C104KA01D	K22124805		1-	B	c5
C 1086	CHIP CAP.	2pF	50V	CK	GRM1884C1H2R0CZ01D	K22174203		1-	A	E4
C 1090	CHIP CAP.	330pF	50V	CH	GRM1882C1H331JA01D	K22174253		1-	A	C5
C 1092	CHIP CAP.	4pF	50V	CH	GRM1882C1H4R0CZ01D	K22174205		1-	A	E4
C 1093	CHIP CAP.	0.1uF	16V	B	GRM188B11C104KA01D	K22124805		1-	B	e2
C 1094	CHIP CAP.	4pF	50V	CH	GRM1882C1H4R0CZ01D	K22174205		1-	A	E4
C 1095	CHIP CAP.	7pF	50V	CH	GRM1882C1H7R0DZ01D	K22174208		1-20	A	E5
C 1095	CHIP CAP.	8pF	50V	CH	GRM1882C1H8R0CZ01D	K22174246	VER. A	21-	A	E5
C 1095	CHIP CAP.	7pF	50V	CH	GRM1882C1H7R0DZ01D	K22174208	VER. D	21-	A	E5
C 1096	CHIP TA.CAP.	33uF	10V		TEESVB21A336M8R	K78100047		1-	B	e4
C 1097	CHIP CAP.	6pF	50V	CH	GRM1882C1H6R0DZ01D	K22174207		1-	A	E4
C 1099	CHIP CAP.	3pF	50V	CJ	GRM1883C1H3R0CZ01D	K22174204		1-	A	E4
C 1101	AL.ELECTRO.CAP.	100uF	16V		EEE1CA101WP	K48120012		1-	A	D2
C 1102	CHIP CAP.	0.001uF	50V	B	GRM188B11H102KA01D	K22174821		1-	B	d2
C 1103	CHIP CAP.	0.01uF	50V	B	GRM188B11H103KA01D	K22174823		1-	B	d2
C 1104	CHIP CAP.	47pF	50V	CH	GRM1882C1H470JA01D	K22174227		1-	A	C4
C 1105	CHIP TA.CAP.	22uF	16V		TEESVB21C226M8R	K78120028		1-	B	d2
C 1107	CHIP CAP.	3pF	50V	CJ	GRM1883C1H3R0CZ01D	K22174204		1-	A	E4
C 1108	CHIP CAP.	0.001uF	50V	B	GRM188B11H102KA01D	K22174821		1-	B	d2
C 1109	AL.ELECTRO.CAP.	100uF	16V		EEE1CA101WP	K48120012		1-	A	C4
C 1110	CHIP CAP.	1uF	10V	F	GRM188F11A105ZA01D	K22105001		1-	B	e5
C 1111	CHIP CAP.	3pF	50V	CJ	GRM1883C1H3R0CZ01D	K22174204		1-	A	E5
C 1112	CHIP CAP.	0.01uF	50V	B	GRM188B11H103KA01D	K22174823		1-	B	d2
C 1115	CHIP CAP.	3pF	50V	CJ	GRM1883C1H3R0CZ01D	K22174204		1-	A	D4
C 1117	CHIP TA.CAP.	47uF	4V		SK7-0G476M-RA	K78060048		1-	B	e4
C 1118	CHIP TA.CAP.	1.5uF	16V		TEESVA1C155M8R	K78120020		1-	A	D1
C 1119	CHIP CAP.	3pF	50V	CJ	GRM1883C1H3R0CZ01D	K22174204		1-	A	D4
C 1120	CHIP CAP.	0.1uF	16V	B	GRM188B11C104KA01D	K22124805		1-	A	D1
C 1121	CHIP CAP.	4pF	50V	CH	GRM1882C1H4R0CZ01D	K22174205		1-	A	E4
C 1122	CHIP CAP.	56pF	50V	CH	GRM1882C1H560JA01D	K22174229		1-	B	e4
C 1123	CHIP CAP.	0.5pF	50V	CK	GRM1884C1HR50CZ01D	K22174201		1-	A	E4
C 1124	CHIP CAP.	0.001uF	50V	B	GRM188B11H102KA01D	K22174821		1-	A	E2
C 1125	CHIP TA.CAP.	0.1uF	35V		TEESVA1V104M8R	K78160025		1-	A	D1
C 1126	CHIP CAP.	270pF	50V	CH	GRM1882C1H271JA01D	K22174251		1-	A	C4
C 1127	CHIP CAP.	100pF	50V	CH	GRM1882C1H101JA01D	K22174235		1-	A	D4
C 1128	CHIP CAP.	15pF	50V	CH	GRM1882C1H150JA01D	K22174215		1-	A	D2
C 1130	CHIP CAP.	680pF	25V	CH	GRM39CH681J25PT	K22144203		1-47	A	C4
C 1130	CHIP CAP.	680pF	50V	CH	GRM1882C1H681JA01D	K22174274		48-	A	C4
C 1131	CHIP CAP.	10pF	50V	CH	GRM1882C1H100JA01D	K22174211		1-	B	c3
C 1132	CHIP TA.CAP.	10uF	10V		TEESVA1A106M8R	K78100028		1-	B	d4
C 1134	CHIP CAP.	8pF	50V	CH	GRM1882C1H8R0DZ01D	K22174209		1-	A	D2
C 1135	CHIP CAP.	15pF	50V	CH	GRM1882C1H150JA01D	K22174215		1-	B	c3
C 1136	CHIP CAP.	100pF	50V	CH	GRM1882C1H101JA01D	K22174235		1-	B	e1
C 1138	CHIP TA.CAP.	1uF	25V		TEESVA1E105M8R	K78140013		1-	B	e4
C 1139	CHIP CAP.	10pF	50V	CH	GRM1882C1H100JA01D	K22174211		1-	B	c2
C 1140	CHIP CAP.	0.001uF	50V	B	GRM188B11H102KA01D	K22174821		1-	A	E3
C 1141	CHIP CAP.	0.001uF	50V	B	GRM188B11H102KA01D	K22174821		1-	A	E3
C 1142	CHIP CAP.	0.001uF	50V	B	GRM188B11H102KA01D	K22174821		1-	B	e4
C 1143	CHIP CAP.	120pF	50V	CH	GRM1882C1H121JA01D	K22174237		1-	A	C3
C 1144	CHIP CAP.	100pF	50V	CH	GRM1882C1H101JA01D	K22174235		1-	B	c2
C 1146	CHIP CAP.	0.0022uF	50V	B	GRM188B11H222KA01D	K22174822		1-	A	C3
C 1148	CHIP CAP.	100pF	50V	CH	GRM1882C1H101JA01D	K22174235		1-	B	b2
C 1149	CHIP CAP.	8pF	50V	CH	GRM1882C1H8R0DZ01D	K22174209		1-	A	E2
C 1150	CHIP CAP.	0.1uF	16V	B	GRM188B11C104KA01D	K22124805		1-	A	B3
C 1151	CHIP CAP.	15pF	50V	CH	GRM1882C1H150JA01D	K22174215		1-20	A	C1
C 1151	CHIP CAP.	9pF	50V	CH	GRM1882C1H9R0DZ01D	K22174210	VER. A	21-22	A	C1
C 1151	CHIP CAP.	10pF	50V	CH	GRM1882C1H100JA01D	K22174211	VER. A	23-	A	C1
C 1151	CHIP CAP.	15pF	50V	CH	GRM1882C1H150JA01D	K22174215	VER. D	21-24	A	C1
C 1151	CHIP CAP.	12pF	50V	CH	GRM1882C1H120JA01D	K22174213	VER. D	25-38	A	C1
C 1151	CHIP CAP.	10pF	50V	CH	GRM1882C1H100JA01D	K22174211	VER. D	39-56	A	C1
C 1151	CHIP CAP.	11pF	50V	CH	GRM1882C1H110JZ01D	K22174212	VER. D	57-	A	C1
C 1153	CHIP CAP.	0.001uF	50V	B	GRM188B11H102KA01D	K22174821		1-	B	b2
C 1154	CHIP CAP.	1pF	50V	CK	GRM1884C1H1R0CZ01D	K22174202		1-20	A	C1
C 1154	CHIP CAP.	2pF	50V	CK	GRM1884C1H2R0CZ01D	K22174203	VER. A	21-22	A	C1
C 1154	CHIP CAP.	2pF	50V	CK	GRM1884C1H2R0CZ01D	K22174203	VER. A	23-	A	C1
C 1154	CHIP CAP.	1pF	50V	CK	GRM1884C1H1R0CZ01D	K22174202	VER. D	21-22	A	C1

REF	DESCRIPTION	VALUE	V/W	TOL.	MFR'S DESIG	VXSTD P/N	VERS.	LOT	SIDE	LAY ADR
C 1154	CHIP CAP.	1pF	50V	CK	GRM1884C1H1R0CZ01D	K22174202	VER. D	23-	A	C1
C 1155	CHIP CAP.	6pF	50V	CH	GRM1882C1H6R0DZ01D	K22174207		1-	B	b2
C 1156	CHIP CAP.	0.001uF	50V	B	GRM188B11H102KA01D	K22174821		1-	B	b2
C 1157	CHIP TA.CAP.	1uF	25V		TEESVA1E105M8R	K78140013		1-	A	B2
C 1158	CHIP CAP.	0.001uF	50V	B	GRM188B11H102KA01D	K22174821		1-	A	E2
C 1159	CHIP CAP.	5pF	50V	CH	GRM1882C1H5R0CZ01D	K22174206		1-20	A	C1
C 1159	CHIP CAP.	3pF	50V	CJ	GRM1883C1H3R0CZ01D	K22174204	VER. A	21-22	A	C1
C 1159	CHIP CAP.	4pF	50V	CH	GRM1882C1H4R0CZ01D	K22174205	VER. A	23-	A	C1
C 1159	CHIP CAP.	5pF	50V	CH	GRM1882C1H5R0CZ01D	K22174206	VER. D	21-	A	C1
C 1160	CHIP CAP.	220pF	50V	CH	GRM1882C1H221JA01D	K22174243		1-	B	e3
C 1161	CHIP CAP.	0.001uF	50V	B	GRM188B11H102KA01D	K22174821		1-	B	c3
C 1162	CHIP CAP.	0.001uF	50V	B	GRM188B11H102KA01D	K22174821		1-	A	B2
C 1163	CHIP CAP.	33pF	50V	CH	GRM1882C1H330JA01D	K22174223		1-	A	B3
C 1164	CHIP CAP.	7pF	50V	CH	GRM1882C1H7R0DZ01D	K22174208		1-22	A	C1
C 1164	CHIP CAP.	8pF	50V	CH	GRM1882C1H8R0DZ01D	K22174209	VER. A	23-	A	C1
C 1164	CHIP CAP.	7pF	50V	CH	GRM1882C1H7R0DZ01D	K22174208	VER. D	23-	A	C1
C 1165	CHIP CAP.	0.001uF	50V	B	GRM188B11H102KA01D	K22174821		1-	A	C1
C 1166	CHIP CAP.	0.01uF	50V	B	GRM188B11H103KA01D	K22174823		1-	B	c3
C 1167	CHIP CAP.	0.0012uF	50V	B	GRM188B11H122KA01D	K22174826		1-	B	e4
C 1168	CHIP CAP.	5pF	50V	CH	GRM1882C1H5R0CZ01D	K22174206		1-	A	C1
C 1169	CHIP CAP.	0.1uF	16V	B	GRM188B11C104KA01D	K22124805		1-	A	B3
C 1171	CHIP CAP.	0.01uF	50V	B	GRM188B11H103KA01D	K22174823		1-	A	D3
C 1172	CHIP CAP.	100pF	50V	CH	GRM1882C1H101JA01D	K22174235		1-	A	D1
C 1173	CHIP CAP.	0.001uF	50V	B	GRM188B11H102KA01D	K22174821		1-	B	e3
C 1174	CHIP TA.CAP.	10uF	10V		TEESVA1A106M8R	K78100028		1-	A	B3
C 1175	CHIP CAP.	0.015uF	25V	B	GRM39B153K25PT	K22144805		1-47	A	B2
C 1175	CHIP CAP.	0.015uF	50V	B	GRM188B11H153KA01D	K22174838		48-	A	B2
C 1176	CHIP CAP.	0.1uF	16V	B	GRM188B11C104KA01D	K22124805		1-	B	d3
C 1178	CHIP CAP.	0.001uF	50V	B	GRM188B11H102KA01D	K22174821		1-	A	D2
C 1179	CHIP CAP.	0.015uF	25V	B	GRM39B153K25PT	K22144805		1-47	A	B2
C 1179	CHIP CAP.	0.015uF	50V	B	GRM188B11H153KA01D	K22174838		48-	A	B2
C 1180	CHIP CAP.	0.01uF	50V	B	GRM188B11H103KA01D	K22174823		1-	B	c3
C 1181	CHIP CAP.	0.5pF	50V	CK	GRM1884C1HR50CZ01D	K22174201		1-22	A	C1
C 1181	CHIP CAP.	1pF	50V	CK	GRM1884C1H1R0CZ01D	K22174202	VER. A	23-	A	C1
C 1181	CHIP CAP.	0.5pF	50V	CK	GRM1884C1HR50CZ01D	K22174201	VER. D	23-	A	C1
C 1182	CHIP CAP.	0.01uF	50V	B	GRM188B11H103KA01D	K22174823		1-	A	D2
C 1183	CHIP CAP.	2pF	50V	CK	GRM1884C1H2R0CZ01D	K22174203		1-	A	D1
C 1184	CHIP CAP.	150pF	50V	CH	GRM1882C1H151JA01D	K22174239		1-	B	e4
C 1186	CHIP CAP.	1pF	50V	CK	GRM1884C1H1R0CZ01D	K22174202		1-	A	C1
C 1187	CHIP CAP.	68pF	50V	CH	GRM1882C1H680JA01D	K22174231		1-	A	B3
C 1189	CHIP TA.CAP.	10uF	10V		TEESVA1A106M8R	K78100028		1-	B	e1
C 1190	CHIP CAP.	0.0047uF	50V	B	ECJ1VB1H472K	K22179622		1-68	A	B2
C 1190	CHIP CAP.	0.0047uF	50V	B	GRM188B11H472KA01D	K22174817		69-	A	B2
C 1191	CHIP CAP.	0.0039uF	50V	B	GRM188B11H392KA01D	K22174830		1-	A	B2
C 1192	CHIP CAP.	0.001uF	50V	B	GRM188B11H102KA01D	K22174821		1-	A	B2
C 1193	CHIP CAP.	0.1uF	16V	B	GRM188B11C104KA01D	K22124805		1-	B	e4
C 1194	CHIP CAP.	0.001uF	50V	B	GRM188B11H102KA01D	K22174821		1-	B	d1
C 1195	CHIP CAP.	0.001uF	50V	B	GRM188B11H102KA01D	K22174821		1-	A	B1
C 1196	CHIP CAP.	100pF	50V	CH	GRM1882C1H101JA01D	K22174235		1-	A	B1
C 1197	CHIP CAP.	8pF	50V	CH	GRM1882C1H8R0DZ01D	K22174209		1-	A	D1
C 1198	CHIP TA.CAP.	10uF	10V		TEESVA1A106M8R	K78100028		1-	B	e4
C 1199	CHIP CAP.	470pF	50V	CH	GRM1882C1H471JA01D	K22174249		1-	A	B1
C 1200	CHIP CAP.	0.01uF	50V	B	GRM188B11H103KA01D	K22174823		1-	B	d1
C 1202	CHIP CAP.	4pF	50V	CH	GRM1882C1H4R0CZ01D	K22174205		1-	A	B1
C 1203	CHIP CAP.	0.01uF	50V	B	GRM188B11H103KA01D	K22174823		1-	A	E1
C 1204	AL.ELECTRO.CAP.	100uF	16V		EEE1CA101WP	K48120012		1-	A	D1
C 1205	CHIP CAP.	0.001uF	50V	B	GRM188B11H102KA01D	K22174821		1-	B	c1
C 1206	CHIP CAP.	39pF	50V	CH	GRM1882C1H390JA01D	K22174225		1-	A	E1
C 1207	CHIP CAP.	0.1uF	16V	B	GRM188B11C104KA01D	K22124805		1-	B	e1
C 1208	CHIP CAP.	33pF	50V	CH	GRM1882C1H330JA01D	K22174223		1-	A	E1
C 1209	CHIP CAP.	4pF	50V	CH	GRM1882C1H4R0CZ01D	K22174205		1-	A	B1
C 1210	CHIP CAP.	0.012uF	50V	B	GRM188B11H123KA01D	K22174825		1-	A	B2
C 1211	CHIP CAP.	330pF	50V	CH	GRM1882C1H331JA01D	K22174253		1-	A	B2
C 1212	CHIP TA.CAP.	22uF	16V		TEESVB21C226M8R	K78120028		1-	B	d1
C 1213	CHIP CAP.	0.033uF	16V	B	ECJ1VB1C333K	K22129515		1-87	A	B2
C 1213	CHIP CAP.	0.033uF	16V	B	GRM188B11C333KA01D	K22124812		88-	A	B2
C 1214	CHIP CAP.	0.0015uF	50V	B	GRM188B11H152KA01D	K22174827		1-	A	B2
C 1215	CHIP CAP.	56pF	50V	CH	GRM1882C1H560JA01D	K22174229		1-	A	B2
C 1216	CHIP CAP.	0.001uF	50V	B	GRM188B11H102KA01D	K22174821		1-	B	d1
C 1218	CHIP CAP.	0.1uF	16V	B	GRM188B11C104KA01D	K22124805		1-	B	b1
C 1219	CHIP CAP.	0.1uF	16V	B	GRM188B11C104KA01D	K22124805		1-	B	b1
C 1221	CHIP CAP.	220pF	50V	CH	GRM1882C1H221JA01D	K22174243		1-	A	B2
C 1222	CHIP CAP.	0.01uF	50V	B	GRM188B11H103KA01D	K22174823		1-	B	d1

MAIN Unit

Parts List

REF	DESCRIPTION	VALUE	V/W	TOL.	MFR'S DESIG	VXSTD P/N	VERS.	LOT	SIDE	LAY ADR
C 1223	CHIP CAP.	0.001uF	50V	B	GRM188B11H102KA01D	K22174821		1-	B	c1
C 1224	CHIP CAP.	0.1uF	16V	B	GRM188B11C104KA01D	K22124805		1-	B	c1
C 1225	CHIP CAP.	0.001uF	50V	B	GRM188B11H102KA01D	K22174821		1-	B	b1
C 1226	CHIP CAP.	82pF	50V	CH	GRM1882C1H820JA01D	K22174233		1-	A	E1
C 1227	CHIP CAP.	0.1uF	16V	B	GRM188B11C104KA01D	K22124805		1-	B	c1
C 1228	CHIP CAP.	56pF	50V	CH	GRM1882C1H560JA01D	K22174229		1-	A	A1
C 1229	CHIP CAP.	0.001uF	50V	B	GRM188B11H102KA01D	K22174821		1-	A	A1
C 1230	CHIP CAP.	180pF	50V	CH	GRM1882C1H181JA01D	K22174241		1-21	A	E1
C 1230	CHIP CAP.	330pF	50V	CH	GRM1882C1H331JA01D	K22174253		22-91	A	E1
C 1230	CHIP CAP.	220pF	50V	CH	GRM1882C1H221JA01D	K22174243		92-	A	E1
C 1231	CHIP CAP.	180pF	50V	CH	GRM1882C1H181JA01D	K22174241		1-21	A	E1
C 1231	CHIP CAP.	330pF	50V	CH	GRM1882C1H331JA01D	K22174253		22-91	A	E1
C 1231	CHIP CAP.	220pF	50V	CH	GRM1882C1H221JA01D	K22174243		92-	A	E1
C 1232	CHIP CAP.	0.001uF	50V	B	GRM188B11H102KA01D	K22174821		1-	B	b1
C 1234	CHIP CAP.	0.1uF	16V	B	GRM188B11C104KA01D	K22124805		1-	A	E1
C 1235	CHIP CAP.	0.001uF	50V	B	GRM188B11H102KA01D	K22174821		1-	B	c1
C 1236	CHIP TA.CAP.	10uF	10V		TEESVA1A106M8R	K78100028		1-	B	c1
C 1237	CHIP CAP.	0.1uF	16V	B	GRM188B11C104KA01D	K22124805		1-	B	b1
C 1238	CHIP CAP.	47pF	50V	CH	GRM1882C1H470JA01D	K22174227		1-	A	B1
C 1239	CHIP CAP.	0.001uF	50V	B	GRM188B11H102KA01D	K22174821		1-	A	A1
C 1240	CHIP TA.CAP.	10uF	10V		TEESVA1A106M8R	K78100028		1-	A	B2
C 1241	CHIP CAP.	0.001uF	50V	B	GRM188B11H102KA01D	K22174821		1-	B	c1
C 1242	CHIP CAP.	100pF	50V	CH	GRM1882C1H101JA01D	K22174235		1-	A	B1
C 1244	CHIP CAP.	0.0047uF	50V	B	GRM188B11H472KA01D	K22174833		1-22	A	D1
C 1244	CHIP CAP.	0.001uF	50V	B	GRM188B11H102KA01D	K22174821	VER. A	23-	A	D1
C 1244	CHIP CAP.	0.0047uF	50V	B	GRM188B11H472KA01D	K22174833	VER. D	23-	A	D1
C 1245	CHIP TA.CAP.	1uF	25V		TEESVA1E105M8R	K78140013		1-	A	B2
C 1246	CHIP CAP.	0.001uF	50V	B	GRM188B11H102KA01D	K22174821		1-	A	B2
C 1247	CHIP CAP.	0.1uF	16V	B	GRM188B11C104KA01D	K22124805		1-	A	E1
C 1249	CHIP TA.CAP.	10uF	10V		TEESVA1A106M8R	K78100028		1-	B	c1
C 1250	CHIP CAP.	0.1uF	16V	B	GRM188B11C104KA01D	K22124805		1-	A	D1
C 1251	CHIP CAP.	470pF	50V	CH	GRM1882C1H471JA01D	K22174249		1-	A	B1
C 1252	CHIP CAP.	0.1uF	16V	B	GRM188B11C104KA01D	K22124805		1-21	A	D1
C 1252	CHIP CAP.	0.33uF	10V	B	GRM188B11A334KA61D	K22104802		22-89	A	D1
C 1254	CHIP CAP.	470pF	50V	CH	GRM1882C1H471JA01D	K22174249		1-	A	A1
C 1255	CHIP CAP.	0.047uF	16V	B	GRM39B473K16PT	K22124804		1-47	A	D1
C 1255	CHIP CAP.	0.047uF	25V	B	GRM188B11E473KA01D	K22144811		48-	A	D1
C 1259	CHIP CAP.	470pF	50V	CH	GRM1882C1H471JA01D	K22174249		1-	A	A1
C 1260	CHIP TA.CAP.	4.7uF	16V		TEESVA1C475M8R	K78120031		1-	A	B3
C 1262	CHIP CAP.	470pF	50V	CH	GRM1882C1H471JA01D	K22174249		1-	A	B1
C 1263	CHIP CAP.	27pF	50V	CH	GRM1882C1H270JA01D	K22174221		1-	A	G1
C 1264	CHIP CAP.	0.001uF	50V	B	GRM188B11H102KA01D	K22174821		1-	A	G1
C 1265	CHIP TA.CAP.	1.5uF	16V		TEESVA1C155M8R	K78120020		1-	A	F2
C 1266	CHIP CAP.	0.033uF	16V	R	GRM188R11C333KA01D	K22124801		1-	A	F1
C 1267	CHIP CAP.	470pF	50V	CH	GRM1882C1H471JA01D	K22174249		1-	A	A1
C 1270	CHIP TA.CAP.	4.7uF	16V		TEESVA1C475M8R	K78120031		1-	B	g4
C 1271	CHIP TA.CAP.	4.7uF	16V		TEESVA1C475M8R	K78120031		1-	A	A3
C 1272	CHIP TA.CAP.	0.1uF	35V		TEESVA1V104M8R	K78160025		1-	A	F2
C 1273	CHIP CAP.	470pF	50V	CH	GRM1882C1H471JA01D	K22174249		1-	A	A1
C 1274	CHIP CAP.	1pF	50V	CK	GRM1884C1H1R0CZ01D	K22174202		1-	A	G3
C 1275	CHIP CAP.	5pF	50V	CH	GRM1882C1H5R0CZ01D	K22174206		1-22	A	G2
C 1275	CHIP CAP.	1pF	50V	CK	GRM1884C1H1R0CZ01D	K22174202	VER. A	23-	A	G2
C 1275	CHIP CAP.	5pF	50V	CH	GRM1882C1H5R0CZ01D	K22174206	VER. D	23-	A	G2
C 1276	CHIP TA.CAP.	1uF	25V		TEESVA1E105M8R	K78140013		1-	B	f3
C 1277	CHIP CAP.	9pF	50V	CH	GRM1882C1H9R0DZ01D	K22174210		1-20	A	G3
C 1277	CHIP CAP.	10pF	50V	CH	GRM1882C1H100JA01D	K22174211	VER. A	21-	A	G3
C 1277	CHIP CAP.	9pF	50V	CH	GRM1882C1H9R0DZ01D	K22174210	VER. D	21-24	A	G3
C 1277	CHIP CAP.	10pF	50V	CH	GRM1882C1H100JA01D	K22174211	VER. D	25-	A	G3
C 1278	CHIP CAP.	9pF	50V	CH	GRM1882C1H9R0DZ01D	K22174210		1-20	A	G3
C 1278	CHIP CAP.	10pF	50V	CH	GRM1882C1H100JA01D	K22174211	VER. A	21-22	A	G3
C 1278	CHIP CAP.	9pF	50V	CH	GRM1882C1H9R0DZ01D	K22174210	VER. D	21-22	A	G3
C 1278	CHIP CAP.	9pF	50V	CH	GRM1882C1H9R0DZ01D	K22174210		23-25	A	G3
C 1278	CHIP CAP.	9pF	50V	CH	GRM1882C1H9R0DZ01D	K22174210	VER. A	26-	A	G3
C 1278	CHIP CAP.	9pF	50V	CH	GRM1882C1H9R0DZ01D	K22174210	VER. D	26-	A	G3
C 1281	CHIP CAP.	0.001uF	50V	B	GRM188B11H102KA01D	K22174821		1-	A	F1
C 1282	CHIP CAP.	0.001uF	50V	B	GRM188B11H102KA01D	K22174821		1-	B	f3
C 1283	CHIP CAP.	3pF	50V	CJ	GRM1883C1H3R0CZ01D	K22174204	VER. A	23-26	A	G4
C 1283	CHIP CAP.	12pF	50V	CH	GRM1882C1H120JA01D	K22174213	VER. A	27-	A	G4
C 1283	CHIP CAP.	2pF	50V	CK	GRM1884C1H2R0CZ01D	K22174203	VER. D	25-	A	G4
C 1284	CHIP CAP.	3pF	50V	CJ	GRM1883C1H3R0CZ01D	K22174204	VER. A	23-	A	G3
C 1285	CHIP CAP.	3pF	50V	CJ	GRM1883C1H3R0CZ01D	K22174204		1-	A	G4
C 1285	CHIP CAP.	4pF	50V	CH	GRM1882C1H4R0CZ01D	K22174205		3-22	A	G4
C 1285	CHIP CAP.	8pF	50V	CH	GRM1882C1H8R0DZ01D	K22174209	VER. A	23-	A	G4

REF	DESCRIPTION	VALUE	V/W	TOL.	MFR'S DESIG	VXSTD P/N	VERS.	LOT	SIDE	LAY ADR
C 1285	CHIP CAP.	4pF	50V	CH	GRM1882C1H4R0CZ01D	K22174205	VER. D	23-24	A	G4
C 1285	CHIP CAP.	8pF	50V	CH	GRM1882C1H8R0DZ01D	K22174209	VER. D	25-	A	G4
C 1286	CHIP CAP.	2pF	50V	CK	GRM1884C1H2R0CZ01D	K22174203		1-	A	G3
C 1286	CHIP CAP.	3pF	50V	CJ	GRM1883C1H3R0CZ01D	K22174204		3-22	A	G3
C 1286	CHIP CAP.	8pF	50V	CH	GRM1882C1H8R0DZ01D	K22174209	VER. A	23-	A	G3
C 1286	CHIP CAP.	3pF	50V	CJ	GRM1883C1H3R0CZ01D	K22174204	VER. D	23-24	A	G3
C 1286	CHIP CAP.	6pF	50V	CH	GRM1882C1H6R0DZ01D	K22174207	VER. D	25-	A	G3
C 1287	CHIP CAP.	0.01uF	50V	B	GRM188B11H103KA01D	K22174823		1-	A	F1
C 1288	CHIP CAP.	0.001uF	50V	B	GRM188B11H102KA01D	K22174821		1-	A	G1
C 1289	AL.ELECTRO.CAP.	100uF	16V		EEE1CA101WP	K48120012		1-	A	F1
C 1290	CHIP TA.CAP.	4.7uF	16V		TEESVA1C475M8R	K78120031		1-	A	A4
C 1291	CHIP TA.CAP.	22uF	16V		TEESVB21C226M8R	K78120028		1-	A	E1
C 1292	CHIP CAP.	7pF	50V	CH	GRM1882C1H7R0DZ01D	K22174208		1-	A	G3
C 1293	CHIP CAP.	7pF	50V	CH	GRM1882C1H7R0DZ01D	K22174208		1-	A	G3
C 1294	CHIP CAP.	0.001uF	50V	B	GRM188B11H102KA01D	K22174821		1-	A	G1
C 1295	CHIP CAP.	220pF	50V	CH	GRM1882C1H221JA01D	K22174243		1-	A	G1
C 1296	CHIP CAP.	6pF	50V	CH	GRM1882C1H6R0DZ01D	K22174207		1-	A	F3
C 1297	CHIP CAP.	6pF	50V	CH	GRM1882C1H6R0DZ01D	K22174207		1-	A	F3
C 1298	CHIP CAP.	0.01uF	50V	B	GRM188B11H103KA01D	K22174823		1-	A	E1
C 1299	CHIP CAP.	0.1uF	16V	B	GRM188B11C104KA01D	K22124805		1-	A	F1
C 1300	CHIP TA.CAP.	10uF	10V		TEESVA1A106M8R	K78100028		1-	A	A3
C 1301	CHIP CAP.	220pF	50V	CH	GRM1882C1H221JA01D	K22174243		1-	A	G1
C 1302	CHIP CAP.	8pF	50V	CH	GRM1882C1H8R0DZ01D	K22174209		1-	A	F3
C 1303	CHIP CAP.	7pF	50V	CH	GRM1882C1H7R0DZ01D	K22174208		1-	A	F3
C 1304	CHIP CAP.	0.001uF	50V	B	GRM188B11H102KA01D	K22174821		1-	A	E1
C 1305	CHIP CAP.	0.01uF	50V	B	GRM188B11H103KA01D	K22174823		1-3	A	F1
C 1305	CHIP CAP.	0.1uF	16V	B	GRM188B11C104KA01D	K22124805	VER. A	21-	A	F1
C 1305	CHIP CAP.	0.01uF	50V	B	GRM188B11H103KA01D	K22174823	VER. D	4-10	A	F1
C 1305	CHIP CAP.	0.1uF	16V	B	GRM188B11C104KA01D	K22124805	VER. D	11-	A	F1
C 1306	CHIP CAP.	0.001uF	50V	B	GRM188B11H102KA01D	K22174821		1-	A	G1
C 1307	CHIP CAP.	47pF	50V	CH	GRM1882C1H470JA01D	K22174227		1-	A	A3
C 1308	CHIP CAP.	0.001uF	50V	B	GRM188B11H102KA01D	K22174821		1-	A	F4
C 1309	CHIP CAP.	0.001uF	50V	B	GRM188B11H102KA01D	K22174821		1-	A	F3
C 1310	CHIP CAP.	470pF	50V	CH	GRM1882C1H471JA01D	K22174249		1-	B	b4
C 1311	CHIP CAP.	470pF	50V	CH	GRM1882C1H471JA01D	K22174249		1-	B	b2
C 1312	CHIP CAP.	0.001uF	50V	B	GRM188B11H102KA01D	K22174821		1-	A	A3
C 1313	CHIP TA.CAP.	1uF	25V		TEESVA1E105M8R	K78140013		1-	B	f2
C 1314	CHIP TA.CAP.	1uF	25V		TEESVA1E105M8R	K78140013		1-	A	A3
C 1315	CHIP CAP.	0.001uF	50V	B	GRM188B11H102KA01D	K22174821		1-	B	f2
C 1316	CHIP CAP.	0.5pF	50V	CK	GRM1884C1HR50CZ01D	K22174201		1-	A	F3
C 1317	CHIP CAP.	0.5pF	50V	CK	GRM1884C1HR50CZ01D	K22174201		1-	A	F3
C 1318	CHIP CAP.	0.01uF	50V	B	GRM188B11H103KA01D	K22174823		1-	A	G2
C 1319	CHIP TA.CAP.	10uF	10V		TEESVA1A106M8R	K78100028		1-	B	a1
C 1320	CHIP TA.CAP.	4.7uF	16V		TEESVA1C475M8R	K78120031		1-	A	B3
C 1321	CHIP TA.CAP.	10uF	10V		TEESVA1A106M8R	K78100028		1-	A	G2
C 1322	CHIP CAP.	0.1uF	16V	B	GRM188B11C104KA01D	K22124805		1-	B	a1
C 1323	CHIP CAP.	0.1uF	16V	B	GRM188B11C104KA01D	K22124805		1-	A	A2
C 1324	CHIP TA.CAP.	4.7uF	16V		TEESVA1C475M8R	K78120031		1-	A	B3
C 1325	CHIP CAP.	0.001uF	50V	B	GRM188B11H102KA01D	K22174821		1-	B	a1
C 1326	CHIP CAP.	0.0033uF	50V	B	GRM188B11H332KA01D	K22174831		1-	B	g2
C 1327	CHIP CAP.	0.001uF	50V	B	GRM188B11H102KA01D	K22174821		1-	A	B3
C 1328	CHIP CAP.	100pF	50V	CH	GRM1882C1H101JA01D	K22174235		1-	B	a2
C 1330	CHIP TA.CAP.	10uF	16V		TEESVB21C106M8R	K78120025		1-	B	g2
C 1331	CHIP CAP.	0.001uF	50V	B	GRM188B11H102KA01D	K22174821		1-	A	F3
C 1332	AL.ELECTRO.CAP.	22uF	16V		ECEV1CA220SR	K48120002		1-25	A	B3
C 1332	AL.ELECTRO.CAP.	22uF	16V		EEE1CA220SR	K48120024		26-	A	B3
C 1333	CHIP TA.CAP.	10uF	10V		TEESVA1A106M8R	K78100028		1-	B	d3
C 1334	CHIP CAP.	0.001uF	50V	B	GRM188B11H102KA01D	K22174821		1-	A	E2
C 1335	CHIP CAP.	0.001uF	50V	B	GRM188B11H102KA01D	K22174821		1-	B	d3
C 1336	CHIP CAP.	0.001uF	50V	B	GRM188B11H102KA01D	K22174821		1-	A	B4
C 1337	CHIP CAP.	0.01uF	50V	B	GRM188B11H103KA01D	K22174823		1-	A	F2
C 1338	CHIP CAP.	0.001uF	50V	B	GRM188B11H102KA01D	K22174821		1-	A	F3
C 1339	CHIP CAP.	220pF	50V	CH	GRM1882C1H221JA01D	K22174243		1-	A	F3
C 1340	AL.ELECTRO.CAP.	100uF	16V		EEE1CA101WP	K48120012		1-	A	F2
C 1341	CHIP CAP.	0.001uF	50V	B	GRM188B11H102KA01D	K22174821		1-	A	B4
C 1342	AL.ELECTRO.CAP.	470uF	16V		RE3-16V471MG3#	K40129066		1-	A	A3
C 1343	CHIP TA.CAP.	22uF	16V		TEESVB21C226M8R	K78120028		1-	A	E2
C 1344	CHIP CAP.	5pF	50V	CH	GRM1882C1H5R0CZ01D	K22174206		1-	A	F3
C 1345	CHIP CAP.	0.1uF	25V	B	GRM21BB11E104KA01L	K22140811		1-	B	g3
C 1346	CHIP CAP.	0.001uF	50V	B	GRM188B11H102KA01D	K22174821		1-	B	d4
C 1347	CHIP CAP.	0.001uF	50V	B	GRM188B11H102KA01D	K22174821		1-	A	A2
C 1348	CHIP CAP.	0.01uF	50V	B	GRM188B11H103KA01D	K22174823		1-	A	E2
C 1349	CHIP CAP.	5pF	50V	CH	GRM1882C1H5R0CZ01D	K22174206		1-	A	F3

MAIN Unit

Parts List

REF	DESCRIPTION	VALUE	V/W	TOL.	MFR'S DESIG	VXSTD P/N	VERS.	LOT	SIDE	LAY ADR
C 1350	AL.ELECTRO.CAP.	470uF	16V		RE3-16V471MG3#	K40129066		1-	A	A2
C 1351	CHIP TA.CAP.	1uF	25V		TEESVA1E105M8R	K78140013		1-	B	d4
C 1352	CHIP CAP.	0.001uF	50V	B	GRM188B11H102KA01D	K22174821		1-	A	E2
C 1353	CHIP CAP.	10pF	50V	CH	GRM1882C1H100JA01D	K22174211		1-	A	A5
C 1354	CHIP CAP.	10pF	50V	CH	GRM1882C1H100JA01D	K22174211		1-	A	A4
C 1355	CHIP CAP.	10pF	50V	CH	GRM1882C1H100JA01D	K22174211		1-	A	A5
C 1356	CHIP CAP.	10pF	50V	CH	GRM1882C1H100JA01D	K22174211		1-	A	A4
C 1357	CHIP CAP.	10pF	50V	CH	GRM1882C1H100JA01D	K22174211		1-	A	A5
C 1358	CHIP CAP.	10pF	50V	CH	GRM1882C1H100JA01D	K22174211		1-	A	B4
C 1359	CHIP CAP.	10pF	50V	CH	GRM1882C1H100JA01D	K22174211		1-	A	B5
C 1360	CHIP CAP.	0.001uF	50V	B	GRM188B11H102KA01D	K22174821		1-	A	A5
C 1361	CHIP CAP.	0.001uF	50V	B	GRM188B11H102KA01D	K22174821		1-	A	A4
C 1362	CHIP CAP.	0.001uF	50V	B	GRM188B11H102KA01D	K22174821		1-	A	B5
C 1363	CHIP CAP.	0.001uF	50V	B	GRM188B11H102KA01D	K22174821		1-	A	B4
C 1364	CHIP CAP.	0.001uF	50V	B	GRM188B11H102KA01D	K22174821		1-	A	B5
C 1365	CHIP CAP.	0.001uF	50V	B	GRM188B11H102KA01D	K22174821		1-	A	B4
C 1366	CHIP CAP.	0.001uF	50V	B	GRM188B11H102KA01D	K22174821		1-	A	B5
C 1367	CHIP CAP.	0.001uF	50V	B	GRM188B11H102KA01D	K22174821		1-	A	B4
C 1368	CHIP CAP.	0.001uF	50V	B	GRM188B11H102KA01D	K22174821		1-	A	B5
C 1369	CHIP CAP.	0.001uF	50V	B	GRM188B11H102KA01D	K22174821		1-	A	B4
C 1370	CHIP CAP.	0.001uF	50V	B	GRM188B11H102KA01D	K22174821		1-	A	B5
C 1371	CHIP CAP.	0.001uF	50V	B	GRM188B11H102KA01D	K22174821		1-	A	B4
C 1372	CHIP CAP.	0.001uF	50V	B	GRM188B11H102KA01D	K22174821		1-	A	B5
C 1373	CHIP CAP.	0.001uF	50V	B	GRM188B11H102KA01D	K22174821		1-	A	B5
C 1374	CHIP CAP.	0.001uF	50V	B	GRM188B11H102KA01D	K22174821		1-	A	B5
C 1375	CHIP CAP.	0.001uF	50V	B	GRM188B11H102KA01D	K22174821		1-	A	B5
C 1376	CHIP CAP.	0.001uF	50V	B	GRM188B11H102KA01D	K22174821		1-	A	B5
C 1377	CHIP CAP.	0.001uF	50V	B	GRM188B11H102KA01D	K22174821		1-	A	B5
C 1378	CHIP CAP.	0.001uF	50V	B	GRM188B11H102KA01D	K22174821		1-	A	B5
C 1379	CHIP CAP.	0.001uF	50V	B	GRM188B11H102KA01D	K22174821		1-	A	B5
C 1380	CHIP CAP.	0.001uF	50V	B	GRM188B11H102KA01D	K22174821		1-	A	B4
C 1381	CHIP CAP.	0.001uF	50V	B	GRM188B11H102KA01D	K22174821		1-	A	B4
C 1382	CHIP CAP.	0.001uF	50V	B	GRM188B11H102KA01D	K22174821		1-	A	A5
C 1383	CHIP CAP.	4pF	50V	CH	GRM1882C1H4R0CZ01D	K22174205		1-20	A	G3
C 1383	CHIP CAP.	6pF	50V	CH	GRM1882C1H6R0DZ01D	K22174207	VER. A	21-22	A	G3
C 1383	CHIP CAP.	2pF	50V	CK	GRM1884C1H2R0CZ01D	K22174203	VER. A	23-	A	G3
C 1383	CHIP CAP.	4pF	50V	CH	GRM1882C1H4R0CZ01D	K22174205	VER. D	21-24	A	G3
C 1383	CHIP CAP.	1pF	50V	CK	GRM1884C1H1R0CZ01D	K22174202	VER. D	25-	A	G3
C 1384	CHIP CAP.	2pF	50V	CK	GRM1884C1H2R0CZ01D	K22174203		1-3	A	G3
C 1384	CHIP CAP.	3pF	50V	CJ	GRM1883C1H3R0CZ01D	K22174204	VER. A	21-22	A	G3
C 1384	CHIP CAP.	1pF	50V	CK	GRM1884C1H1R0CZ01D	K22174202	VER. A	23-30	A	G3
C 1384	CHIP CAP.	2pF	50V	CK	GRM1884C1H2R0CZ01D	K22174203	VER. A	31-	A	G3
C 1384	CHIP CAP.	2pF	50V	CK	GRM1884C1H2R0CZ01D	K22174203	VER. D	4-24	A	G3
C 1385	CHIP TA.CAP.	1uF	25V		TEESVA1E105M8R	K78140013		1-	B	b2
C 1386	CHIP CAP.	100pF	50V	CH	GRM1882C1H101JA01D	K22174235		1-	B	a3
C 1387	CHIP CAP.	100pF	50V	CH	GRM1882C1H101JA01D	K22174235		1-	B	a2
C 1390	CHIP CAP.	0.0039uF	50V	B	GRM188B11H392KA01D	K22174830		1-	A	C4
C 1391	CHIP CAP.	0.0068uF	50V	B	GRM188B11H682KA01D	K22174834		1-	A	C4
C 1392	CHIP CAP.	0.0033uF	50V	B	GRM188B11H332KA01D	K22174831		1-	A	C4
C 1393	CHIP TA.CAP.	47uF	4V		SK7-0G476M-RA	K78060048		1-	B	d3
C 1394	CHIP TA.CAP.	47uF	4V		SK7-0G476M-RA	K78060048		1-	B	e4
C 1395	CHIP TA.CAP.	47uF	4V		SK7-0G476M-RA	K78060048		1-	B	d3
C 1396	CHIP CAP.	0.001uF	50V	B	GRM188B11H102KA01D	K22174821		1-	A	B4
C 1397	CHIP CAP.	0.5pF	50V	CK	GRM1884C1HR50CZ01D	K22174201		1-2	A	G3
C 1397	CHIP CAP.	0.5pF	50V	CK	GRM1884C1HR50CZ01D	K22174201	VER. A	31-32	A	G3
C 1398	CHIP CAP.	0.5pF	50V	CK	GRM1884C1HR50CZ01D	K22174201		3-20	A	G3
C 1398	CHIP CAP.	1pF	50V	CK	GRM1884C1H1R0CZ01D	K22174202	VER. A	21-26	A	G3
C 1398	CHIP CAP.	2pF	50V	CK	GRM1884C1H2R0CZ01D	K22174203	VER. A	27-	A	G3
C 1398	CHIP CAP.	0.5pF	50V	CK	GRM1884C1HR50CZ01D	K22174201	VER. D	21-24	A	G3
C 1399	TANTALUM CAP.	47uF	6.3V		DN0J470M1S	K70087476		3-22	A	D3
C 1399	CHIP TA.CAP.	47uF	6.3V		TEESVA0J476M8R	K78080085	VER. A	23-24	A	D3
C 1399	TANTALUM CAP.	47uF	6.3V		DN0J470M1S	K70087476	VER. D	23-24	A	D3
C 1399	CHIP TA.CAP.	47uF	6.3V		TEESVA0J476M8R	K78080085		25-	A	D3
C 1400	TANTALUM CAP.	47uF	6.3V		DN0J470M1S	K70087476		3-22	A	D3
C 1400	CHIP TA.CAP.	47uF	6.3V		TEESVA0J476M8R	K78080085	VER. A	23-24	A	D3
C 1400	TANTALUM CAP.	47uF	6.3V		DN0J470M1S	K70087476	VER. D	23-24	A	D3
C 1400	CHIP TA.CAP.	47uF	6.3V		TEESVA0J476M8R	K78080085		25-	A	D3
C 1401	CHIP CAP.	2pF	50V	CK	GRM1884C1H2R0CZ01D	K22174203	VER. A	21-22	A	C1
C 1401	CHIP CAP.	4pF	50V	CH	GRM1882C1H4R0CZ01D	K22174205	VER. A	23-	A	C1
C 1401	CHIP CAP.	2pF	50V	CK	GRM1884C1H2R0CZ01D	K22174203	VER. D	11-	A	C1
C 1402	CHIP CAP.	0.001uF	50V	B	GRM155B11H102KA01D	K22178809		11-22	B	b3
C 1402	CHIP CAP.	0.001uF	50V	B	GRM188B11H102KA01D	K22174821	VER. A	23-24	B	b3
C 1402	CHIP CAP.	0.001uF	50V	B	GRM155B11H102KA01D	K22178809	VER. D	23-24	B	b3

MAIN Unit

Parts List

REF	DESCRIPTION	VALUE	V/W	TOL.	MFR'S DESIG	VXSTD P/N	VERS.	LOT	SIDE	LAY ADR
C 1402	CHIP CAP.	0.001uF	50V	B	GRM188B11H102KA01D	K22174821		25-	B	b3
C 1403	CHIP CAP.	0.001uF	50V	B	GRM155B11H102KA01D	K22178809		11-22	B	b2
C 1403	CHIP CAP.	0.001uF	50V	B	GRM188B11H102KA01D	K22174821	VER. A	23-24	B	b2
C 1403	CHIP CAP.	0.001uF	50V	B	GRM155B11H102KA01D	K22178809	VER. D	23-24	B	b2
C 1403	CHIP CAP.	0.001uF	50V	B	GRM188B11H102KA01D	K22174821		25-	B	b2
C 1404	CHIP CAP.	0.001uF	50V	B	GRM155B11H102KA01D	K22178809		11-22	B	b1
C 1404	CHIP CAP.	0.001uF	50V	B	GRM188B11H102KA01D	K22174821	VER. A	23-24	B	b1
C 1404	CHIP CAP.	0.001uF	50V	B	GRM155B11H102KA01D	K22178809	VER. D	23-24	B	b1
C 1404	CHIP CAP.	0.001uF	50V	B	GRM188B11H102KA01D	K22174821		25-	B	b1
C 1405	CHIP CAP.	100pF	50V	CH	GRM2162C1H101JA01D	K22170235		11-22	B	b3
C 1405	CHIP CAP.	100pF	50V	CH	GRM1882C1H101JA01D	K22174235	VER. A	23-24	B	b3
C 1405	CHIP CAP.	100pF	50V	CH	GRM2162C1H101JA01D	K22170235	VER. D	23-24	B	b3
C 1405	CHIP CAP.	100pF	50V	CH	GRM1882C1H101JA01D	K22174235		25-	B	b3
C 1406	CHIP CAP.	100pF	50V	CH	GRM2162C1H101JA01D	K22170235		11-22	B	b3
C 1406	CHIP CAP.	100pF	50V	CH	GRM1882C1H101JA01D	K22174235	VER. A	23-24	B	b3
C 1406	CHIP CAP.	100pF	50V	CH	GRM2162C1H101JA01D	K22170235	VER. D	23-24	B	b3
C 1406	CHIP CAP.	100pF	50V	CH	GRM1882C1H101JA01D	K22174235		25-	B	b3
C 1407	CHIP CAP.	0.33uF	10V	B	GRM188B11A334KA61D	K22104802		22	A	E1
C 1407	CHIP CAP.	0.33uF	10V	B	GRM188B11A334KA61D	K22104802	VER. A	23-	A	E1
C 1407	CHIP CAP.	0.33uF	10V	B	GRM188B11A334KA61D	K22104802	VER. D	23-	A	E1
C 1408	CHIP CAP.	1pF	50V	CK	GRM1884C1H1R0CZ01D	K22174202	VER. A	27-		
C 1408	CHIP CAP.	1pF	50V	CK	GRM1884C1H1R0CZ01D	K22174202	VER. D	25-38		
C 1451	CHIP CAP.	1pF	50V	CK	GRM1884C1H1R0CZ01D	K22174202	VER. A	21-22	A	G3
C 1451	CHIP CAP.	0.5pF	50V	CK	GRM1884C1HR50CZ01D	K22174201	VER. D	25-	A	G3
C 1452	CHIP CAP.	6pF	50V	CH	GRM1882C1H6R0DZ01D	K22174207	VER. A	21-		
C 1453	CHIP CAP.	6pF	50V	CH	GRM1882C1H6R0DZ01D	K22174207	VER. A	21-		
C 1455	CHIP CAP.	0.1uF	16V	B	GRM188B11C104KA01D	K22124805	VER. A	23-24	B	f2
C 1455	CHIP CAP.	0.1uF	16V	B	GRM188B11C104KA01D	K22124805		25-	B	f2
C 1456	CHIP CAP.	15pF	50V	CH	GRM1882C1H150JA01D	K22174215	VER. A	23-24	A	D2
C 1456	CHIP CAP.	15pF	50V	CH	GRM1882C1H150JA01D	K22174215		25-	A	D2
C 1501	CHIP CAP.	0.001uF	50V	B	GRM188B11H102KA01D	K22174821		3-	B	c3
C 1502	CHIP CAP.	0.01uF	50V	B	GRM188B11H103KA01D	K22174823		3-	B	c2
C 1503	CHIP CAP.	0.01uF	50V	B	GRM188B11H103KA01D	K22174823		3-	B	c2
C 1504	CHIP CAP.	0.001uF	50V	B	GRM188B11H102KA01D	K22174821		3-	B	c2
C 1505	CHIP CAP.	15pF	50V	CH	GRM1882C1H150JA01D	K22174215		3-	B	c2
C 1506	CHIP CAP.	8pF	50V	CH	GRM1882C1H8R0DZ01D	K22174209		3-	B	d2
C 1508	CHIP CAP.	8pF	50V	CH	GRM1882C1H8R0DZ01D	K22174209		3-	B	d2
C 1510	CHIP CAP.	0.001uF	50V	B	GRM188B11H102KA01D	K22174821		3-	B	c1
C 1511	CHIP CAP.	0.1uF	16V	B	GRM188B11C104KA01D	K22124805	VER. A	23-24	B	c2
C 1511	CHIP CAP.	0.1uF	16V	B	GRM188B11C104KA01D	K22124805		25-	B	c2
C 1512	CHIP CAP.	100pF	50V	CH	GRM1882C1H101JA01D	K22174235		3-	B	c2
C 1513	CHIP CAP.	0.001uF	50V	B	GRM188B11H102KA01D	K22174821		3-	B	c2
C 1514	CHIP CAP.	0.01uF	50V	B	GRM188B11H103KA01D	K22174823		3-	B	c2
C 1515	CHIP CAP.	2pF	50V	CK	GRM1884C1H2R0CZ01D	K22174203		3-	B	c2
C 1515	CHIP CAP.	2pF	50V	CK	GRM1884C1H2R0CZ01D	K22174203		16-22	B	c2
C 1515	CHIP CAP.	8pF	50V	CH	GRM1882C1H8R0DZ01D	K22174209	VER. A	23-24	B	c2
C 1515	CHIP CAP.	8pF	50V	CH	GRM1882C1H8R0DZ01D	K22174209		25-	B	c2
C 1517	CHIP CAP.	8pF	50V	CH	GRM1882C1H8R0DZ01D	K22174209		3-	B	c1
C 1518	CHIP CAP.	0.01uF	50V	B	GRM188B11H103KA01D	K22174823		3-	B	c1
C 1520	CHIP CAP.	0.001uF	50V	B	GRM188B11H102KA01D	K22174821		3-	B	c1
C 1521	CHIP CAP.	0.001uF	50V	B	GRM188B11H102KA01D	K22174821		3-	B	c1
C 1522	CHIP CAP.	0.01uF	50V	B	GRM188B11H103KA01D	K22174823		3-	B	c2
C 1527	CHIP CAP.	0.001uF	50V	B	GRM188B11H102KA01D	K22174821	VER. A	23-24	A	E1
C 1527	CHIP CAP.	0.001uF	50V	B	GRM188B11H102KA01D	K22174821		25-	A	E1
C 1528	CHIP CAP.	0.001uF	50V	B	GRM188B11H102KA01D	K22174821	VER. A	23-24	A	E1
C 1528	CHIP CAP.	0.001uF	50V	B	GRM188B11H102KA01D	K22174821		25-	A	E1
C 1529	CHIP CAP.	0.001uF	50V	B	GRM188B11H102KA01D	K22174821	VER. A	23-24	B	c1
C 1529	CHIP CAP.	0.001uF	50V	B	GRM188B11H102KA01D	K22174821		25-	B	c1
C 1530	CHIP CAP.	27pF	50V	CH	GRM1882C1H270JA01D	K22174221	VER. A	23-24	B	d2
C 1530	CHIP CAP.	27pF	50V	CH	GRM1882C1H270JA01D	K22174221		25-	B	d2
C 1532	CHIP CAP.	27pF	50V	CH	GRM1882C1H270JA01D	K22174221	VER. A	23-24	B	c1
C 1532	CHIP CAP.	27pF	50V	CH	GRM1882C1H270JA01D	K22174221		25-	B	c1
C 1534	CHIP CAP.	0.1uF	16V	B	GRM188B11C104KA01D	K22124805	VER. A	23-24	A	E2
C 1534	CHIP CAP.	0.1uF	16V	B	GRM188B11C104KA01D	K22124805		25-	A	E2
CD1001	CERAMIC DISC				CDBLA455KCAY07-B0	H7900180		1-	A	E1
CF1001	CERAMIC FILTER				CFWLB455KGFA-B0	H3900399		1-	A	F1
CF1002	CERAMIC FILTER				CFWLB455KFFA-B0	H3900395		1-	A	F1
D 1001	DIODE				1SS302(TE85R.F)	G2070088		1-	A	G4
D 1002	DIODE				RN739F T106	G2070626		1-	A	G4
D 1003	DIODE				HVU350 TRF-E	G2070380		1-	A	G5
D 1004	DIODE				HVU350 TRF-E	G2070380		1-	A	F5
D 1005	DIODE				HVU350 TRF-E	G2070380		1-	A	E5
D 1006	DIODE				HZU5ALL-TRF-E	G2070754		1-	B	e2

MAIN Unit

Parts List

REF	DESCRIPTION	VALUE	V/W	TOL.	MFR'S DESIG	VXSTD P/N	VERS.	LOT	SIDE	LAY ADR
D 1007	DIODE				HVU350 TRF-E	G2070380		1-	A	E5
D 1008	DIODE				1SV282(TPH3.F)	G2070778		1-	A	C1
D 1009	DIODE				1SV282(TPH3.F)	G2070778		1-	A	C1
D 1010	DIODE				HVU350 TRF-E	G2070380		1-	A	C1
D 1011	DIODE				HZM5.6NB2 TR-E	G2070722		1-	B	d3
D 1012	DIODE				MA142WK-(TX)	G2070534		1-94	B	b1
D 1012	DIODE				DA3J103E0L	G2071346		95-	B	b1
D 1013	DIODE				MA142WK-(TX)	G2070534		1-94	B	b1
D 1013	DIODE				DA3J103E0L	G2071346		95-	B	b1
D 1014	DIODE				MA143-(TX)	G2070536		1-126	A	D1
D 1014	DIODE				DA3J101F0L	G2071354		127-	A	D1
D 1015	DIODE				MA143-(TX)	G2070536		1-126	A	E1
D 1015	DIODE				DA3J101F0L	G2071354		127-	A	E1
D 1016	DIODE				RN739F T106	G2070626		1-	A	B1
D 1017	DIODE				RN739F T106	G2070626		1-	A	B1
D 1018	DIODE				1SV282(TPH3.F)	G2070778		1-	A	G3
D 1019	DIODE				1SV282(TPH3.F)	G2070778		1-	A	G3
D 1020	DIODE				1SV282(TPH3.F)	G2070778		1-	A	G2
D 1021	DIODE				1SV282(TPH3.F)	G2070778		1-	A	G2
D 1022	DIODE				HZU5ALL-TRF-E	G2070754		1-	B	b1
D 1023	DIODE				MA143-(TX)	G2070536		1-126	A	C4
D 1023	DIODE				DA3J101F0L	G2071354		127-	A	C4
D 1024	DIODE				MA143-(TX)	G2070536		1-126	A	C3
D 1024	DIODE				DA3J101F0L	G2071354		127-	A	C3
D 1025	DIODE				MA143-(TX)	G2070536		1-126	A	B4
D 1025	DIODE				DA3J101F0L	G2071354		127-	A	B4
D 1026	DIODE				MA143-(TX)	G2070536		1-126	A	B3
D 1026	DIODE				DA3J101F0L	G2071354		127-	A	B3
D 1501	DIODE				1SS321(TE85R.F)	G2070076		16-22	B	c2
D 1501	DIODE				DAN235K T97	G2070082	VER. A	23-24	B	c2
D 1501	DIODE				DAN235K T97	G2070082		25-	B	c2
D 1502	DIODE				1SS321(TE85R.F)	G2070076		16-22	B	c1
D 1502	DIODE				DAN235K T97	G2070082	VER. A	23-24	B	c1
D 1502	DIODE				DAN235K T97	G2070082		25-	B	c1
J 1001	CONNECTOR				TMP-J01X-V6	P1090210		1-	A	G4
J 1002	CONNECTOR				SB20-02WS	P0090609		1-	A	A3
J 1003	CONNECTOR				SB20-02WS	P0090609		1-	A	A4
J 1004	CONNECTOR				SB20-03WS	P0090610		1-	A	A3
J 1005	CONNECTOR				FH12-50S-0.5SV	P1091092		1-	A	B4
J 1006	CONNECTOR				SC25-02WS	P0090621		1-	A	A2
J 1007	CONNECTOR				TMP-J01X-V6	P1090210		1-	A	A1
JP1001	WIRE ASSY				GRN 35 2/2	T50503500		1-2	B	f1
JP1002	WIRE ASSY				GRN 105 2/2	T50510500		1-2		
JP1003	WIRE ASSY				GRN 45 2/2	T50504500		1-2		
L 1001	M.RFC	3.3uH			LK1608 3R3K-T	L1690686		1-	A	G4
L 1002	M.RFC	4.7uH			LK1608 4R7K-T	L1690688		1-	A	C3
L 1003	COIL				E2 0.35-1.6-4T-L	L0022456		1-20	A	F4
L 1003	COIL				E2 0.35-1.6-4.5T-L	L0022577	VER. A	21-	A	F4
L 1003	COIL				E2 0.35-1.6-4T-L	L0022456	VER. D	21-	A	F4
L 1004	COIL				E2 0.35-1.6-4T-L	L0022456		1-20	A	F4
L 1004	COIL				E2 0.35-1.6-4.5T-L	L0022577	VER. A	21-	A	F4
L 1004	COIL				E2 0.35-1.6-4T-L	L0022456	VER. D	21-	A	F4
L 1005	M.RFC	0.015uH			LL1608-F15NK	L1690361		1-	A	F4
L 1006	M.RFC	4.7uH			LK1608 4R7K-T	L1690688		1-	A	C2
L 1007	M.RFC	3.3uH			LK1608 3R3K-T	L1690686		1-	A	C2
L 1008	CHIP COIL	0.017uH			LQW31HN17NJ03L	L1690249		1-	A	F4
L 1009	CHIP COIL	0.47uH			C2520C-R47J	L1690552		1-	A	C2
L 1010	COIL				E2 0.35-1.6-4T-L	L0022456		1-20	A	E4
L 1010	COIL				E2 0.35-1.6-4.5T-L	L0022577	VER. A	21-	A	E4
L 1010	COIL				E2 0.35-1.6-4T-L	L0022456	VER. D	21-	A	E4
L 1011	COIL				E2 0.35-1.6-4T-L	L0022456		1-20	A	E4
L 1011	COIL				E2 0.35-1.6-4.5T-L	L0022577	VER. A	21-	A	E4
L 1011	COIL				E2 0.35-1.6-4T-L	L0022456	VER. D	21-	A	E4
L 1012	COIL				E2 0.35-1.6-4T-L	L0022456		1-20	A	E5
L 1012	COIL				E2 0.35-1.6-4.5T-L	L0022577	VER. A	21-	A	E5
L 1012	COIL				E2 0.35-1.6-4T-L	L0022456	VER. D	21-	A	E5
L 1013	COIL				E2 0.35-1.6-4T-L	L0022456		1-20	A	D5
L 1013	COIL				E2 0.35-1.6-4.5T-L	L0022577	VER. A	21-	A	D5
L 1013	COIL				E2 0.35-1.6-4T-L	L0022456	VER. D	21-	A	D5
L 1014	CHIP COIL	0.22uH			C2520C-R22J	L1690548		1-	A	E2
L 1015	M.RFC	0.022uH			HK2125 22NJ-T	L1690381		1-	B	c3
L 1016	M.RFC	0.022uH			HK2125 22NJ-T	L1690381		1-	B	c2
L 1017	CHIP COIL	0.33uH			C2520C-R33J	L1690550		1-	A	C1

MAIN Unit

Parts List

REF	DESCRIPTION	VALUE	V/W	TOL.	MFR'S DESIG	VXSTD P/N	VERS.	LOT	SIDE	LAY ADR
L 1018	M.RFC	0.022uH			HK1608 22NJ-T	L1690520		1-	B	c2
L 1019	CHIP COIL	0.33uH			C2520C-R33J	L1690550		1-	A	C1
L 1020	M.RFC	0.0185uH			C3328A-18NG-RA-T25H	L1691078		1-20	A	C1
L 1020	M.RFC	0.028uH		2%	C6328A-28NG-RA-T25H	L1691081	VER. A	21-22	A	C1
L 1020	M.RFC	0.0185uH			C3328A-18NG-RA-T25H	L1691078	VER. D	21-	A	C1
L 1021	CHIP COIL	0.68uH			C2520C-R68J	L1690554		1-	A	E2
L 1022	CHIP COIL	0.33uH			C2520C-R33J	L1690550		1-	A	C1
L 1023	M.RFC	10uH			LK2125 100K-T	L1690331		1-	B	c3
L 1024	M.RFC	0.1uH			LK2125 R10K-T	L1690307		1-	A	D2
L 1024	M.RFC	0.1uH			LK2125 R10K-T	L1690307		16-22	A	D2
L 1024	M.RFC	0.27uH			LK2125 R27K-T	L1690312	VER. A	23-24	A	D2
L 1024	M.RFC	0.1uH			LK2125 R10K-T	L1690307	VER. D	23-24	A	D2
L 1024	M.RFC	0.27uH			LK2125 R27K-T	L1690312		25-	A	D2
L 1025	CHIP COIL	0.33uH			C2520C-R33J	L1690550		1-3	A	C1
L 1025	CHIP COIL	0.1uH			C2520C-R10J	L1690544	VER. A	21-	A	C1
L 1025	CHIP COIL	0.33uH			C2520C-R33J	L1690550	VER. D	4-10	A	C1
L 1025	CHIP COIL	0.1uH			C2520C-R10J	L1690544	VER. D	11-	A	C1
L 1026	M.RFC	0.082uH			HK1608 82NJ-T	L1690527		1-	A	B1
L 1027	M.RFC	1uH		5%	C2012C-1R0J	L1691160		1-	A	E1
L 1029	M.RFC	0.33uH			LK2125 R33K-T	L1690313		1-	A	E1
L 1030	CHIP COIL	0.018uH			C2520C-18NK	L1690535		1-	A	B1
L 1031	M.RFC	0.012uH			HK1608 12NJ-T	L1690517		1-	A	A1
L 1032	M.RFC	4.7uH			LK1608 4R7K-T	L1690688		1-	A	G1
L 1033	CHIP COIL	0.33uH			C2520C-R33J	L1690550		1-	A	G3
L 1034	CHIP COIL	0.33uH			C2520C-R33J	L1690550		1-	A	G2
L 1035	CHIP COIL	0.33uH			C2520C-R33J	L1690550		1-	A	G3
L 1036	CHIP COIL	0.33uH			C2520C-R33J	L1690550		1-	A	G2
L 1037	M.RFC	0.022uH		2%	C6328A-22NG-RA-T25H	L1691080		1-20	A	G3
L 1037	M.RFC	0.028uH		2%	C6328A-28NG-RA-T25H	L1691081	VER. A	21-	A	G3
L 1037	M.RFC	0.022uH		2%	C6328A-22NG-RA-T25H	L1691080	VER. D	21-	A	G3
L 1038	M.RFC	0.022uH		2%	C6328A-22NG-RA-T25H	L1691080		1-20	A	G3
L 1038	M.RFC	0.028uH		2%	C6328A-28NG-RA-T25H	L1691081	VER. A	21-	A	G3
L 1038	M.RFC	0.022uH		2%	C6328A-22NG-RA-T25H	L1691080	VER. D	21-	A	G3
L 1039	M.RFC	3.3uH			LK1608 3R3K-T	L1690686		1-	A	G1
L 1040	CHIP COIL	0.33uH			C2520C-R33J	L1690550		1-	A	F4
L 1041	CHIP COIL	0.33uH			C2520C-R33J	L1690550		1-	A	F3
L 1042	CHIP COIL	0.47uH			C2520C-R47J	L1690552		1-	A	G1
L 1043	CHIP COIL	0.33uH			C2520C-R33J	L1690550		1-	A	F3
L 1044	CHIP COIL	0.33uH			C2520C-R33J	L1690550		1-	A	F2
L 1045	M.RFC	4.7uH			LK1608 4R7K-T	L1690688		1-	A	G1
L 1046	CHIP COIL	0.082uH			C2520C-82NK	L1690543		1-	A	F3
L 1047	CHIP COIL	0.022uH			C2520C-22NK	L1690536		1-	A	F3
L 1048	M.RFC	0.022uH		2%	C6328A-22NG-RA-T25H	L1691080	VER. A	23-	A	C1
L 1451	M.RFC	0.027uH			HK1608 27NJ-T	L1690521	VER. A	21-		
L 1452	M.RFC	0.027uH			HK1608 27NJ-T	L1690521	VER. A	21-		
L 1453	M.RFC	0.027uH			HK1608 27NJ-T	L1690521	VER. A	21-		
L 1454	M.RFC	0.027uH			HK1608 27NJ-T	L1690521	VER. A	21-		
L 1501	CHIP COIL	0.22uH			C2520C-R22J	L1690548		3-	B	c2
L 1502	CHIP COIL	0.68uH			C2520C-R68J	L1690554		3-	B	c2
L 1503	M.RFC	0.1uH			LK2125 R10K-T	L1690307		3-	B	c2
L 1503	M.RFC	0.1uH			LK2125 R10K-T	L1690307		16-22	B	c2
L 1503	M.RFC	0.27uH			LK2125 R27K-T	L1690312	VER. A	23-24	B	c2
L 1503	M.RFC	0.27uH			LK2125 R27K-T	L1690312		25-	B	c2
L 1504	M.RFC	1uH		5%	C2012C-1R0J	L1691160		3-	B	c1
L 1504	M.RFC	0.56uH		5%	C2012C-R56J	L1691020		23-	B	c1
L 1505	M.RFC	4.7uH			LK1608 4R7K-T	L1690688	VER. A	23-24	B	c3
L 1505	M.RFC	4.7uH			LK1608 4R7K-T	L1690688		25-	B	c3
L 1506	M.RFC	4.7uH			LK1608 4R7K-T	L1690688	VER. A	23-24	B	c2
L 1506	M.RFC	4.7uH			LK1608 4R7K-T	L1690688		25-	B	c2
L 1507	M.RFC	4.7uH			LK1608 4R7K-T	L1690688	VER. A	23-24	B	c2
L 1507	M.RFC	4.7uH			LK1608 4R7K-T	L1690688		25-	B	c2
L 1508	M.RFC	4.7uH			LK1608 4R7K-T	L1690688	VER. A	23-24	B	c1
L 1508	M.RFC	4.7uH			LK1608 4R7K-T	L1690688		25-	B	c1
L 1509	M.RFC	4.7uH			LK1608 4R7K-T	L1690688	VER. A	23-24	B	c1
L 1509	M.RFC	4.7uH			LK1608 4R7K-T	L1690688		25-	B	c1
L 1510	M.RFC	4.7uH			LK1608 4R7K-T	L1690688	VER. A	23-24	B	c1
L 1510	M.RFC	4.7uH			LK1608 4R7K-T	L1690688		25-	B	c1
Q 1001	IC				NJM2902V-TE1	G1091679		1-	A	C4
Q 1002	TRANSISTOR				2SD1664 T100 Q	G3416647Q		1-	B	e3
Q 1003	IC				TA75S01F(TE85R.F)	G1091593		1-	B	e3
Q 1004	IC				NJM2904V-TE1	G1091677		1-	A	D3
Q 1005	IC				TAR5S30(TE85L.F)	G1093570		1-	B	d1
Q 1006	IC				M51132FP 600C	G1091930		1-	A	D4

MAIN Unit

Parts List

REF	DESCRIPTION	VALUE	V/W	TOL.	MFR'S DESIG	VXSTD P/N	VERS.	LOT	SIDE	LAY ADR
Q 1007	TRANSISTOR				2SC4116GR(TE85R.F)	G3341167G		1-	A	C2
Q 1008	IC				MB15A02PFV1-G-BND-EFE1	G1092541		1-	A	C2
Q 1009	TRANSISTOR				2SC3357-T2 RF	G3333577F		1-	A	F4
Q 1010	IC				NJM2904V-TE1	G1091677		1-	B	e4
Q 1012	TRANSISTOR				2SA1586Y(TE85R.F)	G3115867Y		1-	B	e2
Q 1013	TRANSISTOR				UN5215-(TX)	G3070193		1-99	B	e2
Q 1013	TRANSISTOR				DRC5114T0L	G3070444		100-	B	e2
Q 1014	TRANSISTOR				2SA1162GR TE85R	G3111627G		1-	B	e1
Q 1015	TRANSISTOR				2SC2712GR(TE85R.F)	G3327127G		1-	B	e1
Q 1016	TRANSISTOR				2SC4116GR(TE85R.F)	G3341167G		1-	B	d2
Q 1017	IC				NJM2902V-TE1	G1091679		1-	A	C4
Q 1018	IC				SPM5001-TL-E	G1093686		1-80	A	E3
Q 1018	IC				SPM5002-TL-E	G1094899		81-	A	E3
Q 1019	TRANSISTOR				2SC3357-T2 RF	G3333577F		1-	B	b2
Q 1020	IC				NJM2904V-TE1	G1091677		1-	A	B3
Q 1021	FET				2SK508-T2B K52 A	G3805087B		1-	A	C1
Q 1022	TRANSISTOR				2SC5226-4/5-TL	G3352268Z		1-	A	D1
Q 1023	TRANSISTOR				2SC2812N6-CPA-TB-E	G3328128F		1-124	B	d3
Q 1023	TRANSISTOR				MMBT6428LT1G	G3070500		125-	B	d3
Q 1024	TRANSISTOR				XN1213-(TX)	G3070194		1-115	B	e1
Q 1024	TRANSISTOR				DMC261030L	G3070445		116-	B	e1
Q 1025	IC				NJM2902V-TE1	G1091679		1-	A	B2
Q 1026	TRANSISTOR				2SC5226-4/5-TL	G3352268Z		1-	A	B1
Q 1027	TRANSISTOR				2SC4116GR(TE85R.F)	G3341167G		1-	B	d1
Q 1028	IC				TA31136FNG(EL)	G1091605		1-91	A	E1
Q 1028	IC				AA32416	G1094857		92-	A	E1
Q 1029	TRANSISTOR				2SB1122S-TD	G3211228S		1-	B	d5
Q 1030	TRANSISTOR				2SC3357-T2 RF	G3333577F		1-	A	A1
Q 1031	TRANSISTOR				XN1213-(TX)	G3070194		1-115	B	d5
Q 1031	TRANSISTOR				DMC261030L	G3070445		116-	B	d5
Q 1032	TRANSISTOR				UN5213-(TX)	G3070192		1-104	B	g1
Q 1032	TRANSISTOR				DRC5144E	G3070440		105-	B	g1
Q 1033	TRANSISTOR				2SC4116GR(TE85R.F)	G3341167G		1-	A	E1
Q 1034	TRANSISTOR				2SA1179N6-CPA-TB	G3111797F		1-	B	g1
Q 1035	TRANSISTOR				XN1213-(TX)	G3070194		1-115	B	b1
Q 1035	TRANSISTOR				DMC261030L	G3070445		116-	B	b1
Q 1036	TRANSISTOR				XN1213-(TX)	G3070194		1-115	B	f1
Q 1036	TRANSISTOR				DMC261030L	G3070445		116-	B	f1
Q 1037	TRANSISTOR				DTA144EE TL	G3070074		1-	B	f1
Q 1039	TRANSISTOR				XN1213-(TX)	G3070194		1-115	B	d1
Q 1039	TRANSISTOR				DMC261030L	G3070445		116-	B	d1
Q 1040	IC				BU4066BCFV-E2	G1093537		1-	B	g3
Q 1041	TRANSISTOR				2SA1162GR TE85R	G3111627G		1-	B	b1
Q 1042	TRANSISTOR				2SC2712GR(TE85R.F)	G3327127G		1-	B	b1
Q 1043	TRANSISTOR				DTC144EK T146	G3070033		1-	B	g4
Q 1044	TRANSISTOR				FMG2 T148	G3070015		1-	B	g4
Q 1045	TRANSISTOR				2SC4116GR(TE85R.F)	G3341167G		1-	A	G1
Q 1046	TRANSISTOR				2SC4116GR(TE85R.F)	G3341167G		1-	A	F1
Q 1047	TRANSISTOR				UN5215-(TX)	G3070193		1-99	A	F1
Q 1047	TRANSISTOR				DRC5114T0L	G3070444		100-	A	F1
Q 1048	FET				2SK508-T2B K52 A	G3805087B		1-	A	F3
Q 1049	FET				2SK508-T2B K52 A	G3805087B		1-	A	F3
Q 1050	IC				NJM2904V-TE1	G1091677		1-	A	A3
Q 1051	TRANSISTOR				2SA1586Y(TE85R.F)	G3115867Y		1-	A	F1
Q 1052	IC				MB15A02PFV1-G-BND-EFE1	G1092541		1-	A	G1
Q 1053	TRANSISTOR				DTC144EE TL	G3070075		1-3	B	b4
Q 1053	TRANSISTOR				RT1N441U-T11-1	G3070247	VER. A	21-	B	b4
Q 1053	TRANSISTOR				DTC144EE TL	G3070075	VER. D	4-10	B	b4
Q 1053	TRANSISTOR				RT1N441U-T11-1	G3070247	VER. D	11-	B	b4
Q 1054	TRANSISTOR				DTC144EE TL	G3070075		1-3	B	b2
Q 1054	TRANSISTOR				RT1N441U-T11-1	G3070247	VER. A	21-	B	b2
Q 1054	TRANSISTOR				DTC144EE TL	G3070075	VER. D	4-10	B	b2
Q 1054	TRANSISTOR				RT1N441U-T11-1	G3070247	VER. D	11-	B	b2
Q 1055	IC				M62364FP 600D	G1093033		1-	B	f2
Q 1056	IC				M51132FP 600C	G1091930		1-	A	B3
Q 1057	IC				TDA2003V-PBF	G1090769		1-	A	A2
Q 1058	TRANSISTOR				2SC4116GR(TE85R.F)	G3341167G		1-	B	b2
Q 1059	TRANSISTOR				2SC5226-4/5-TL	G3352268Z		1-	A	F3
Q 1060	TRANSISTOR				DTC144EE TL	G3070075		1-3	B	b2
Q 1060	TRANSISTOR				RT1N441U-T11-1	G3070247	VER. A	21-	B	b2
Q 1060	TRANSISTOR				DTC144EE TL	G3070075	VER. D	4-10	B	b2
Q 1060	TRANSISTOR				RT1N441U-T11-1	G3070247	VER. D	11-	B	b2
Q 1061	TRANSISTOR				2SC4116GR(TE85R.F)	G3341167G		1-	A	E2

MAIN Unit

Parts List

REF	DESCRIPTION	VALUE	V/W	TOL.	MFR'S DESIG	VXSTD P/N	VERS.	LOT	SIDE	LAY ADR
Q 1062	IC				L78M05T-TL	G1091731		1-	B	d3
Q 1501	TRANSISTOR				XN1213-(TX)	G3070194		3-115	B	c1
Q 1501	TRANSISTOR				DMC261030L	G3070445		116-	B	c1
Q 1502	TRANSISTOR				2SC5226-4/5-TL	G3352268Z		3-	B	c2
Q 1503	TRANSISTOR				XN1213-(TX)	G3070194		3-	A	E1
Q 1504	TRANSISTOR				2SC4116GR(TE85R.F)	G3341167G		3-	B	c1
R 1001	CHIP RES.	10k	1/16W	5%	RMC1/16 103JATP	J24185103		1-	A	G4
R 1002	CHIP RES.	100	1/16W	5%	RMC1/16 101JATP	J24185101		1-	A	G5
R 1003	CHIP RES.	150	1W	5%	RMC1 151JTE	J24305151		1-	B	e3
R 1004	CHIP RES.	100k	1/16W	5%	RMC1/16 104JATP	J24185104		1-	A	D3
R 1005	CHIP RES.	39k	1/16W	5%	RMC1/16 393JATP	J24185393		1-	B	e3
R 1007	CHIP RES.	150	1W	5%	RMC1 151JTE	J24305151		1-	B	e3
R 1009	CHIP RES.	56k	1/16W	5%	RMC1/16 563JATP	J24185563		1-	B	e3
R 1010	CHIP RES.	10k	1/16W	1%	RMC1/16 103FTP	J24183103		1-	A	C3
R 1011	CHIP RES.	10k	1/16W	1%	RMC1/16 103FTP	J24183103		1-	A	C3
R 1012	CHIP RES.	56k	1/16W	5%	RMC1/16 563JATP	J24185563		1-	B	e3
R 1013	CHIP RES.	100k	1/16W	5%	RMC1/16 104JATP	J24185104		1-	A	D3
R 1014	CHIP RES.	3.3k	1/16W	5%	RMC1/16 332JATP	J24185332		1-	B	e3
R 1016	CHIP RES.	100k	1/16W	5%	RMC1/16 104JATP	J24185104		1-2	A	D3
R 1016	CHIP RES.	47k	1/16W	5%	RMC1/16 473JATP	J24185473		3-	A	D3
R 1017	CHIP RES.	100k	1/16W	5%	RMC1/16 104JATP	J24185104		1-	B	e3
R 1018	CHIP RES.	100k	1/16W	5%	RMC1/16 104JATP	J24185104		1-	A	F5
R 1019	CHIP RES.	1k	1/16W	5%	RMC1/16 102JATP	J24185102		1-	B	d4
R 1020	CHIP RES.	680	1/16W	5%	RMC1/16 681JATP	J24185681		1-	B	d4
R 1021	CHIP RES.	100k	1/16W	5%	RMC1/16 104JATP	J24185104		1-	A	F5
R 1022	CHIP RES.	8.2k	1/16W	5%	RMC1/16 822JATP	J24185822		1-	B	d3
R 1023	CHIP RES.	0	1/16W	5%	RMC1/16 000JATP	J24185000		1-	A	C4
R 1024	CHIP RES.	100k	1/16W	5%	RMC1/16 104JATP	J24185104		1-	A	D3
R 1025	CHIP RES.	10k	1/16W	5%	RMC1/16 103JATP	J24185103		1-	A	C3
R 1027	CHIP RES.	100k	1/16W	5%	RMC1/16 104JATP	J24185104		1-	A	D4
R 1029	CHIP RES.	47k	1/16W	5%	RMC1/16 473JATP	J24185473		1-	A	D3
R 1030	CHIP RES.	47	1/16W	5%	RMC1/16 470JATP	J24185470		1-	A	C2
R 1031	CHIP RES.	100k	1/16W	5%	RMC1/16 104JATP	J24185104		1-	A	D3
R 1032	CHIP RES.	100k	1/16W	5%	RMC1/16 104JATP	J24185104		1-	A	D4
R 1033	CHIP RES.	18k	1/16W	5%	RMC1/16 183JATP	J24185183		1-	A	C2
R 1034	CHIP RES.	12k	1/16W	5%	RMC1/16 123JATP	J24185123		1-	A	C3
R 1035	CHIP RES.	4.7k	1/16W	5%	RMC1/16 472JATP	J24185472		1-	A	F4
R 1036	CHIP RES.	33k	1/16W	5%	RMC1/16 333JATP	J24185333		1-	A	C4
R 1037	CHIP RES.	12k	1/16W	5%	RMC1/16 123JATP	J24185123		1-2	B	d3
R 1037	CHIP RES.	6.8k	1/16W	5%	RMC1/16 682JATP	J24185682		3-	B	d3
R 1038	CHIP RES.	10k	1/16W	5%	RMC1/16 103JATP	J24185103		1-	A	F4
R 1039	CHIP RES.	100	1/16W	5%	RMC1/16 101JATP	J24185101		1-	A	F4
R 1040	CHIP RES.	220	1/16W	5%	RMC1/16 221JATP	J24185221		1-	A	C2
R 1041	CHIP RES.	56	1/16W	5%	RMC1/16 560JATP	J24185560		1-	A	C3
R 1042	CHIP RES.	0	1/16W	5%	RMC1/16 000JATP	J24185000		1-	A	C2
R 1043	CHIP RES.	100	1/16W	5%	RMC1/16 101JATP	J24185101		1-	A	F5
R 1044	CHIP RES.	2.2k	1/16W	5%	RMC1/16 222JATP	J24185222		1-56	A	F5
R 1044	CHIP RES.	1k	1/16W	5%	RMC1/16 102JATP	J24185102	VER. A	57-89	A	F5
R 1044	CHIP RES.	470	1/16W	5%	RMC1/16 471JATP	J24185471	VER. A	90-	A	F5
R 1044	CHIP RES.	2.2k	1/16W	5%	RMC1/16 222JATP	J24185222	VER. D	57-	A	F5
R 1045	CHIP RES.	0	1/16W	5%	RMC1/16 000JATP	J24185000		1-	A	C2
R 1046	CHIP RES.	10k	1/16W	5%	RMC1/16 103JATP	J24185103		1-	B	d3
R 1047	CHIP RES.	33k	1/16W	5%	RMC1/16 333JATP	J24185333		1-	A	C4
R 1049	CHIP RES.	10k	1/16W	5%	RMC1/16 103JATP	J24185103		1-	A	D4
R 1050	CHIP RES.	100k	1/16W	5%	RMC1/16 104JATP	J24185104		1-22	A	C5
R 1050	CHIP RES.	150k	1/16W	5%	RMC1/16 154JATP	J24185154	VER. A	23-52	A	C5
R 1050	CHIP RES.	180k	1/16W	5%	RMC1/16 184JATP	J24185184	VER. A	53-	A	C5
R 1050	CHIP RES.	100k	1/16W	5%	RMC1/16 104JATP	J24185104	VER. D	23-	A	C5
R 1052	CHIP RES.	1k	1/16W	5%	RMC1/16 102JATP	J24185102		1-	A	C2
R 1053	CHIP RES.	1k	1/16W	5%	RMC1/16 102JATP	J24185102		1-	A	C2
R 1055	CHIP RES.	47k	1/16W	5%	RMC1/16 473JATP	J24185473		1-	A	D4
R 1056	CHIP RES.	39k	1/16W	5%	RMC1/16 393JATP	J24185393		1-	B	e4
R 1057	CHIP RES.	1k	1/16W	5%	RMC1/16 102JATP	J24185102		1-	A	C2
R 1060	CHIP RES.	100k	1/16W	5%	RMC1/16 104JATP	J24185104		1-	A	E5
R 1061	CHIP RES.	33k	1/16W	5%	RMC1/16 333JATP	J24185333		1-	B	e2
R 1062	CHIP RES.	100k	1/16W	5%	RMC1/16 104JATP	J24185104		1-	B	e2
R 1063	CHIP RES.	0	1/16W	5%	RMC1/16 000JATP	J24185000		1-	B	e2
R 1065	CHIP RES.	100k	1/16W	5%	RMC1/16 104JATP	J24185104		1-	A	E5
R 1066	CHIP RES.	10k	1/16W	5%	RMC1/16 103JATP	J24185103		1-22	B	e2
R 1066	CHIP RES.	6.8k	1/16W	5%	RMC1/16 682JATP	J24185682	VER. A	23-	B	e2
R 1066	CHIP RES.	10k	1/16W	5%	RMC1/16 103JATP	J24185103	VER. D	23-	B	e2
R 1067	CHIP RES.	10k	1/16W	5%	RMC1/16 103JATP	J24185103		1-22	B	e1
R 1067	CHIP RES.	6.8k	1/16W	5%	RMC1/16 682JATP	J24185682	VER. A	23-	B	e1

MAIN Unit

Parts List

REF	DESCRIPTION	VALUE	V/W	TOL.	MFR'S DESIG	VXSTD P/N	VERS.	LOT	SIDE	LAY ADR
R 1067	CHIP RES.	10k	1/16W	5%	RMC1/16 103JATP	J24185103	VER. D	23-	B	e1
R 1069	CHIP RES.	180k	1/16W	5%	RMC1/16 184JATP	J24185184		1-	A	C5
R 1070	CHIP RES.	10k	1/16W	5%	RMC1/16 103JATP	J24185103		1-	B	e2
R 1071	CHIP RES.	22k	1/16W	5%	RMC1/16 223JATP	J24185223		1-	B	e4
R 1072	CHIP RES.	0	1/16W	5%	RMC1/16 000JATP	J24185000		1-	B	e2
R 1073	CHIP RES.	0	1/16W	5%	RMC1/16 000JATP	J24185000		1-	B	d4
R 1074	CHIP RES.	1k	1/16W	5%	RMC1/16 102JATP	J24185102		1-	B	e4
R 1075	CHIP RES.	10	1/16W	5%	RMC1/16 100JATP	J24185100		1-	B	d2
R 1076	CHIP RES.	0	1/16W	5%	RMC1/16 000JATP	J24185000		1-	B	d2
R 1077	CHIP RES.	4.7k	1/16W	5%	RMC1/16 472JATP	J24185472		1-	B	e1
R 1078	CHIP RES.	4.7k	1/16W	5%	RMC1/16 472JATP	J24185472		1-	B	e1
R 1080	CHIP RES.	10k	1/16W	5%	RMC1/16 103JATP	J24185103		1-	A	C4
R 1081	CHIP RES.	4.7k	1/16W	5%	RMC1/16 472JATP	J24185472		1-	A	C4
R 1082	CHIP RES.	2.2k	1/16W	5%	RMC1/16 222JATP	J24185222		1-	B	d2
R 1083	CHIP RES.	0	1/16W	5%	RMC1/16 000JATP	J24185000		1-	B	e2
R 1084	CHIP RES.	680	1/16W	5%	RMC1/16 681JATP	J24185681		1-	B	e4
R 1085	CHIP RES.	0	1/16W	5%	RMC1/16 000JATP	J24185000		1-	B	e2
R 1086	CHIP RES.	4.7k	1/16W	5%	RMC1/16 472JATP	J24185472		1-	B	e2
R 1087	CHIP RES.	0	1/16W	5%	RMC1/16 000JATP	J24185000		1-	B	d1
R 1088	CHIP RES.	100	1/16W	5%	RMC1/16 101JATP	J24185101		1-	B	d1
R 1089	CHIP RES.	100	1/16W	5%	RMC1/16 101JATP	J24185101		1-	B	d1
R 1090	CHIP RES.	0	1/16W	5%	RMC1/16 000JATP	J24185000		1-	B	e1
R 1092	CHIP RES.	68k	1/16W	5%	RMC1/16 683JATP	J24185683		1-	A	C4
R 1093	CHIP RES.	560	1/16W	5%	RMC1/16 561JATP	J24185561		1-	A	D1
R 1094	CHIP RES.	100k	1/16W	5%	RMC1/16 104JATP	J24185104		1-2	B	e4
R 1094	CHIP RES.	39k	1/16W	5%	RMC1/16 393JATP	J24185393		3	B	e4
R 1094	CHIP RES.	33k	1/16W	5%	RMC1/16 333JATP	J24185333	VER. A	21-22	B	e4
R 1094	CHIP RES.	56k	1/16W	5%	RMC1/16 563JATP	J24185563	VER. A	23-52	B	e4
R 1094	CHIP RES.	68k	1/16W	5%	RMC1/16 683JATP	J24185683	VER. A	53-	B	e4
R 1094	CHIP RES.	39k	1/16W	5%	RMC1/16 393JATP	J24185393	VER. D	4-11	B	e4
R 1094	CHIP RES.	33k	1/16W	5%	RMC1/16 333JATP	J24185333	VER. D	12-25	B	e4
R 1094	CHIP RES.	27k	1/16W	5%	RMC1/16 273JATP	J24185273	VER. D	26-	B	e4
R 1095	CHIP RES.	82k	1/16W	5%	RMC1/16 823JATP	J24185823		1-	A	C4
R 1096	CHIP RES.	47k	1/16W	5%	RMC1/16 473JATP	J24185473		1-22	B	e4
R 1096	CHIP RES.	56k	1/16W	5%	RMC1/16 563JATP	J24185563	VER. A	23-50	B	e4
R 1096	CHIP RES.	82k	1/16W	5%	RMC1/16 823JATP	J24185823	VER. A	51-	B	e4
R 1096	CHIP RES.	47k	1/16W	5%	RMC1/16 473JATP	J24185473	VER. D	23-	B	e4
R 1097	CHIP RES.	3.3k	1/16W	5%	RMC1/16 332JATP	J24185332		1-	A	D1
R 1098	CHIP RES.	3.3k	1/16W	5%	RMC1/16 332JATP	J24185332		1-	A	D1
R 1099	CHIP RES.	0	1/16W	5%	RMC1/16 000JATP	J24185000		1-	B	c3
R 1101	CHIP RES.	270k	1/16W	5%	RMC1/16 274JATP	J24185274		1-	B	e4
R 1102	CHIP RES.	0	1/16W	5%	RMC1/16 000JATP	J24185000		1-	B	c3
R 1104	CHIP RES.	56	1/16W	5%	RMC1/16 560JATP	J24185560		1-	B	c3
R 1105	CHIP RES.	0	1/16W	5%	RMC1/16 000JATP	J24185000		1-	A	D1
R 1107	CHIP RES.	3.9k	1/16W	5%	RMC1/16 392JATP	J24185392		1-	B	e4
R 1108	CHIP RES.	100k	1/16W	5%	RMC1/16 104JATP	J24185104		1-45	A	C4
R 1108	CHIP RES.	100k	1/16W	5%	RMC1/16 104JATP	J24185104	AUS	46-	A	C4
R 1108	CHIP RES.	100k	1/16W	5%	RMC1/16 104JATP	J24185104	EXP	46-	A	C4
R 1108	CHIP RES.	100k	1/16W	5%	RMC1/16 104JATP	J24185104	USA	46-	A	C4
R 1109	CHIP RES.	100k	1/16W	5%	RMC1/16 104JATP	J24185104		1-45	A	C4
R 1109	CHIP RES.	100k	1/16W	5%	RMC1/16 104JATP	J24185104	AUS	46-	A	C4
R 1109	CHIP RES.	100k	1/16W	5%	RMC1/16 104JATP	J24185104	EXP	46-	A	C4
R 1109	CHIP RES.	100k	1/16W	5%	RMC1/16 104JATP	J24185104	USA	46-	A	C4
R 1110	CHIP RES.	4.7k	1/16W	5%	RMC1/16 472JATP	J24185472		1-	B	e4
R 1112	CHIP RES.	8.2k	1/16W	5%	RMC1/16 822JATP	J24185822		1-	B	e4
R 1114	CHIP RES.	100	1/16W	5%	RMC1/16 101JATP	J24185101		1-	A	D2
R 1115	CHIP RES.	10k	1/16W	5%	RMC1/16 103JATP	J24185103		1-	B	e4
R 1116	CHIP RES.	33	1/16W	5%	RMC1/16 330JATP	J24185330		1-	A	C1
R 1117	CHIP RES.	100	1/16W	1%	RMC1/16 101FTP	J24183101		1-	A	E3
R 1118	CHIP RES.	100	1/16W	1%	RMC1/16 101FTP	J24183101		1-	A	E3
R 1119	CHIP RES.	0	1/16W	5%	RMC1/16 000JATP	J24185000		1	A	B3
R 1119	CHIP RES.	6.8k	1/16W	5%	RMC1/16 682JATP	J24185682		2-3	A	B3
R 1119	CHIP RES.	10k	1/16W	5%	RMC1/16 103JATP	J24185103		4-91	A	B3
R 1119	CHIP RES.	33k	1/16W	5%	RMC1/16 333JATP	J24185333		92-	A	B3
R 1121	CHIP RES.	100k	1/16W	5%	RMC1/16 104JATP	J24185104		1-45	A	C3
R 1121	CHIP RES.	100k	1/16W	5%	RMC1/16 104JATP	J24185104	AUS	46-	A	C3
R 1121	CHIP RES.	100k	1/16W	5%	RMC1/16 104JATP	J24185104	EXP	46-	A	C3
R 1121	CHIP RES.	100k	1/16W	5%	RMC1/16 104JATP	J24185104	USA	46-	A	C3
R 1122	CHIP RES.	100k	1/16W	5%	RMC1/16 104JATP	J24185104		1-45	A	C3
R 1122	CHIP RES.	100k	1/16W	5%	RMC1/16 104JATP	J24185104	AUS	46-	A	C3
R 1122	CHIP RES.	100k	1/16W	5%	RMC1/16 104JATP	J24185104	EXP	46-	A	C3
R 1122	CHIP RES.	100k	1/16W	5%	RMC1/16 104JATP	J24185104	USA	46-	A	C3
R 1123	CHIP RES.	47	1/16W	5%	RMC1/16 470JATP	J24185470		1-	B	b2

MAIN Unit

Parts List

REF	DESCRIPTION	VALUE	V/W	TOL.	MFR'S DESIG	VXSTD P/N	VERS.	LOT	SIDE	LAY ADR
R 1124	CHIP RES.	100k	1/16W	5%	RMC1/16 104JATP	J24185104		1-	A	B3
R 1125	CHIP RES.	180	1/16W	5%	RMC1/16 181JATP	J24185181		1-	A	E2
R 1126	CHIP RES.	10	1/10W	5%	RMC1/10T 100J	J24205100		1-	B	c2
R 1127	CHIP RES.	10k	1/16W	5%	RMC1/16 103JATP	J24185103		1-	B	b2
R 1128	CHIP RES.	4.7k	1/16W	5%	RMC1/16 472JATP	J24185472		1-	B	b2
R 1129	CHIP RES.	470k	1/16W	5%	RMC1/16 474JATP	J24185474		1-	A	B3
R 1130	CHIP RES.	33	1/16W	5%	RMC1/16 330JATP	J24185330		1-	A	C1
R 1131	CHIP RES.	68k	1/16W	5%	RMC1/16 683JATP	J24185683		1-	A	D2
R 1133	CHIP RES.	100k	1/16W	5%	RMC1/16 104JATP	J24185104		1-45	B	e4
R 1133	CHIP RES.	100k	1/16W	5%	RMC1/16 104JATP	J24185104	AUS	46-	B	e4
R 1133	CHIP RES.	100k	1/16W	5%	RMC1/16 104JATP	J24185104	EXP	46-	B	e4
R 1133	CHIP RES.	100k	1/16W	5%	RMC1/16 104JATP	J24185104	USA	46-	B	e4
R 1134	CHIP RES.	100k	1/16W	5%	RMC1/16 104JATP	J24185104		1-45	B	e4
R 1134	CHIP RES.	100k	1/16W	5%	RMC1/16 104JATP	J24185104	AUS	46-	B	e4
R 1134	CHIP RES.	100k	1/16W	5%	RMC1/16 104JATP	J24185104	EXP	46-	B	e4
R 1134	CHIP RES.	100k	1/16W	5%	RMC1/16 104JATP	J24185104	USA	46-	B	e4
R 1135	CHIP RES.	10k	1/16W	5%	RMC1/16 103JATP	J24185103		1-	A	B3
R 1136	CHIP RES.	6.8k	1/16W	5%	RMC1/16 682JATP	J24185682		1-	A	B3
R 1137	CHIP RES.	47k	1/16W	5%	RMC1/16 473JATP	J24185473		1-	A	B3
R 1138	CHIP RES.	120k	1/16W	1%	RMC1/16 124FTP	J24183124		1-	A	B2
R 1139	CHIP RES.	150	1/16W	5%	RMC1/16 151JATP	J24185151		1-	A	C1
R 1140	CHIP RES.	0	1/16W	5%	RMC1/16 000JATP	J24185000		1-	A	C1
R 1142	CHIP RES.	0	1/16W	5%	RMC1/16 000JATP	J24185000		1-2	A	E1
R 1142	CHIP RES.	10k	1/16W	5%	RMC1/16 103JATP	J24185103		3-15	A	E1
R 1142	CHIP RES.	10k	1/16W	5%	RMC1/16 103JATP	J24185103		16-22	A	E1
R 1142	CHIP RES.	2.2k	1/16W	5%	RMC1/16 222JATP	J24185222	VER A	23-24	A	E1
R 1142	CHIP RES.	2.2k	1/16W	5%	RMC1/16 222JATP	J24185222		25-	A	E1
R 1143	CHIP RES.	150	1/16W	5%	RMC1/16 151JATP	J24185151		1-	A	D1
R 1146	CHIP RES.	100k	1/16W	5%	RMC1/16 104JATP	J24185104		1-45	B	e3
R 1146	CHIP RES.	100k	1/16W	5%	RMC1/16 104JATP	J24185104	AUS	46-	B	e3
R 1146	CHIP RES.	100k	1/16W	5%	RMC1/16 104JATP	J24185104	EXP	46-	B	e3
R 1146	CHIP RES.	100k	1/16W	5%	RMC1/16 104JATP	J24185104	USA	46-	B	e3
R 1147	CHIP RES.	470k	1/16W	1%	RMC1/16 474FTP	J24183474		1-	A	B2
R 1148	CHIP RES.	100	1/16W	5%	RMC1/16 101JATP	J24185101		1-	A	D2
R 1149	CHIP RES.	150k	1/16W	5%	RMC1/16 154JATP	J24185154		1-	A	B3
R 1150	CHIP RES.	68k	1/16W	5%	RMC1/16 683JATP	J24185683		1-	A	C1
R 1151	CHIP RES.	39k	1/16W	5%	RMC1/16 393JATP	J24185393		1-	A	C1
R 1152	CHIP RES.	470k	1/16W	1%	RMC1/16 474FTP	J24183474		1-	A	B2
R 1153	CHIP RES.	330	1/10W	5%	RMC1/10T 331J	J24205331		1-	B	d2
R 1154	CHIP RES.	12k	1/16W	5%	RMC1/16 123JATP	J24185123		1-22	A	C1
R 1154	CHIP RES.	39k	1/16W	5%	RMC1/16 393JATP	J24185393	VER A	23-	A	C1
R 1154	CHIP RES.	12k	1/16W	5%	RMC1/16 123JATP	J24185123	VER D	23-	A	C1
R 1155	CHIP RES.	82k	1/16W	5%	RMC1/16 823JATP	J24185823		1-	B	e4
R 1156	CHIP RES.	1k	1/16W	5%	RMC1/16 102JATP	J24185102		1-	A	B2
R 1157	CHIP RES.	47	1/16W	5%	RMC1/16 470JATP	J24185470		1-	A	B1
R 1158	CHIP RES.	3.3k	1/16W	5%	RMC1/16 332JATP	J24185332		1-	A	B1
R 1159	CHIP RES.	2.2k	1/16W	5%	RMC1/16 222JATP	J24185222		1-	A	B1
R 1160	CHIP RES.	33k	1/16W	5%	RMC1/16 333JATP	J24185333		1-	B	e4
R 1161	CHIP RES.	10k	1/16W	5%	RMC1/16 103JATP	J24185103		1-	B	e4
R 1162	CHIP RES.	330	1/16W	5%	RMC1/16 331JATP	J24185331		1-	A	B1
R 1163	CHIP RES.	150	1/16W	5%	RMC1/16 151JATP	J24185151		1-	A	E1
R 1164	CHIP RES.	10k	1/16W	5%	RMC1/16 103JATP	J24185103		1-	B	e1
R 1165	CHIP RES.	470k	1/16W	1%	RMC1/16 474FTP	J24183474		1-	A	B2
R 1166	CHIP RES.	470k	1/16W	1%	RMC1/16 474FTP	J24183474		1-	A	B2
R 1167	CHIP RES.	22k	1/16W	5%	RMC1/16 223JATP	J24185223		1-	B	b1
R 1168	CHIP RES.	470k	1/16W	1%	RMC1/16 474FTP	J24183474		1-	A	B2
R 1169	CHIP RES.	10	1/16W	5%	RMC1/16 100JATP	J24185100		1-	A	B1
R 1170	CHIP RES.	470k	1/16W	1%	RMC1/16 474FTP	J24183474		1-	A	B2
R 1171	CHIP RES.	6.8k	1/16W	5%	RMC1/16 682JATP	J24185682		1-	A	E1
R 1172	CHIP RES.	18	1/16W	5%	RMC1/16 180JATP	J24185180		1-	A	B1
R 1173	CHIP RES.	10	1/16W	5%	RMC1/16 100JATP	J24185100		1-	A	B1
R 1174	CHIP RES.	10	1/16W	5%	RMC1/16 100JATP	J24185100		1-	B	d1
R 1175	CHIP RES.	2.2k	1/16W	5%	RMC1/16 222JATP	J24185222		1-	B	d1
R 1176	CHIP RES.	33k	1/16W	5%	RMC1/16 333JATP	J24185333		1-	B	b1
R 1177	CHIP RES.	33k	1/16W	5%	RMC1/16 333JATP	J24185333		1-	B	b1
R 1178	CHIP RES.	10k	1/16W	5%	RMC1/16 103JATP	J24185103		1-	B	d5
R 1179	CHIP RES.	1.2k	1/16W	5%	RMC1/16 122JATP	J24185122		1-	B	c1
R 1180	CHIP RES.	10k	1/16W	5%	RMC1/16 103JATP	J24185103		1-	B	d5
R 1181	CHIP RES.	6.8k	1/16W	5%	RMC1/16 682JATP	J24185682		1-	A	A1
R 1182	CHIP RES.	5.6k	1/16W	5%	RMC1/16 562JATP	J24185562		1-	A	A1
R 1183	CHIP RES.	33k	1/16W	5%	RMC1/16 333JATP	J24185333		1-	B	b1
R 1184	CHIP RES.	33k	1/16W	5%	RMC1/16 333JATP	J24185333		1-	B	b1
R 1185	CHIP RES.	10k	1/16W	5%	RMC1/16 103JATP	J24185103		1-	B	b1

MAIN Unit

Parts List

REF	DESCRIPTION	VALUE	V/W	TOL.	MFR'S DESIG	VXSTD P/N	VERS.	LOT	SIDE	LAY ADR
R 1186	CHIP RES.	150k	1/16W	5%	RMC1/16 154JATP	J24185154		1-21	A	E1
R 1186	CHIP RES.	180k	1/16W	5%	RMC1/16 184JATP	J24185184		22-91	A	E1
R 1186	CHIP RES.	390k	1/16W	5%	RMC1/16 394JATP	J24185394		92-	A	E1
R 1187	CHIP RES.	4.7k	1/16W	5%	RMC1/16 472JATP	J24185472		1-	B	d5
R 1188	CHIP RES.	10	1/16W	5%	RMC1/16 100JATP	J24185100		1-	A	B1
R 1189	CHIP RES.	10k	1/16W	5%	RMC1/16 103JATP	J24185103		1-	A	B2
R 1190	CHIP RES.	47	1/10W	5%	RMC1/10T 470J	J24205470		1-	A	A1
R 1191	CHIP RES.	1.8k	1/16W	5%	RMC1/16 182JATP	J24185182		1-21	B	c1
R 1191	CHIP RES.	2.2k	1/16W	5%	RMC1/16 222JATP	J24185222		22-	B	c1
R 1192	CHIP RES.	10k	1/16W	5%	RMC1/16 103JATP	J24185103		1-	B	d5
R 1193	CHIP RES.	6.8k	1/16W	5%	RMC1/16 682JATP	J24185682		1-	A	B2
R 1194	CHIP RES.	22k	1/16W	5%	RMC1/16 223JATP	J24185223		1-	B	b1
R 1195	CHIP RES.	10k	1/16W	5%	RMC1/16 103JATP	J24185103		1-	B	g1
R 1196	CHIP RES.	10k	1/16W	5%	RMC1/16 103JATP	J24185103		1-	B	f1
R 1197	CHIP RES.	10k	1/16W	5%	RMC1/16 103JATP	J24185103		1-	B	g1
R 1198	CHIP RES.	1.8k	1/16W	5%	RMC1/16 182JATP	J24185182		1-21	B	c1
R 1198	CHIP RES.	1k	1/16W	5%	RMC1/16 102JATP	J24185102		22-	B	c1
R 1199	CHIP RES.	6.8k	1/16W	5%	RMC1/16 682JATP	J24185682		1-	A	E1
R 1200	CHIP RES.	10k	1/16W	5%	RMC1/16 103JATP	J24185103		1-	B	b1
R 1201	CHIP RES.	100k	1/16W	5%	RMC1/16 104JATP	J24185104		1-	B	g1
R 1202	CHIP RES.	220k	1/16W	5%	RMC1/16 224JATP	J24185224		1-	A	E1
R 1203	CHIP RES.	47	1/16W	5%	RMC1/16 470JATP	J24185470		1-	B	c1
R 1204	CHIP RES.	18k	1/16W	5%	RMC1/16 183JATP	J24185183		1-	A	B2
R 1205	CHIP RES.	10k	1/16W	5%	RMC1/16 103JATP	J24185103		1-	A	B2
R 1207	CHIP RES.	0	1/16W	5%	RMC1/16 000JATP	J24185000		1-20	A	B1
R 1207	CHIP RES.	0	1/16W	5%	RMC1/16 000JATP	J24185000	VER. D	21-	A	B1
R 1209	CHIP RES.	1k	1/16W	5%	RMC1/16 102JATP	J24185102		1-	A	E1
R 1210	CHIP RES.	100	1/16W	5%	RMC1/16 101JATP	J24185101		1-	A	E1
R 1212	CHIP RES.	6.8k	1/16W	5%	RMC1/16 682JATP	J24185682		1-	B	d1
R 1214	CHIP RES.	0	1/16W	5%	RMC1/16 000JATP	J24185000		1-	A	D1
R 1215	CHIP RES.	12k	1/16W	5%	RMC1/16 123JATP	J24185123		1-	A	D1
R 1216	CHIP RES.	18k	1/16W	5%	RMC1/16 183JATP	J24185183		1-	A	D1
R 1217	CHIP RES.	0	1/16W	5%	RMC1/16 000JATP	J24185000		1-	A	D1
R 1219	CHIP RES.	820	1/16W	5%	RMC1/16 821JATP	J24185821		1-	A	B1
R 1220	CHIP RES.	10k	1/16W	5%	RMC1/16 103JATP	J24185103		1-	B	d1
R 1221	CHIP RES.	4.7k	1/16W	5%	RMC1/16 472JATP	J24185472		1-	B	d1
R 1222	CHIP RES.	27k	1/16W	5%	RMC1/16 273JATP	J24185273		1-	A	D1
R 1223	CHIP RES.	820	1/16W	5%	RMC1/16 821JATP	J24185821		1-	A	B1
R 1224	CHIP RES.	47k	1/16W	5%	RMC1/16 473JATP	J24185473		1-	B	g4
R 1225	CHIP RES.	47k	1/16W	5%	RMC1/16 473JATP	J24185473		1-	B	f3
R 1226	CHIP RES.	560	1/16W	5%	RMC1/16 561JATP	J24185561		1-	A	F1
R 1227	CHIP RES.	33	1/16W	5%	RMC1/16 330JATP	J24185330		1-	A	G3
R 1228	CHIP RES.	33	1/16W	5%	RMC1/16 330JATP	J24185330		1-	A	G2
R 1229	CHIP RES.	0	1/16W	5%	RMC1/16 000JATP	J24185000		1-	B	b1
R 1230	CHIP RES.	100	1/16W	5%	RMC1/16 101JATP	J24185101		1-	B	b1
R 1230	CHIP RES.	100	1/16W	5%	RMC1/16 101JATP	J24185101	VER. A	92-	B	b1
R 1230	CHIP RES.	0	1/16W	5%	RMC1/16 000JATP	J24185000	VER. D	92-	B	b1
R 1231	CHIP RES.	100	1/16W	5%	RMC1/16 101JATP	J24185101		1-	B	b1
R 1231	CHIP RES.	100	1/16W	5%	RMC1/16 101JATP	J24185101	VER. A	92-	B	b1
R 1231	CHIP RES.	0	1/16W	5%	RMC1/16 000JATP	J24185000	VER. D	92-	B	b1
R 1232	CHIP RES.	0	1/16W	5%	RMC1/16 000JATP	J24185000		1-	B	a2
R 1233	CHIP RES.	10k	1/16W	5%	RMC1/16 103JATP	J24185103		1-18	B	g3
R 1233	CHIP RES.	470k	1/16W	5%	RMC1/16 474JATP	J24185474		19-	B	g3
R 1234	CHIP RES.	220k	1/16W	1%	RMC1/16 224FTP	J24183224		1-	A	G1
R 1235	CHIP RES.	220k	1/16W	1%	RMC1/16 224FTP	J24183224		1-	A	G1
R 1236	CHIP RES.	1.8k	1/16W	5%	RMC1/16 182JATP	J24185182		1-	A	F2
R 1236	CHIP RES.	1.8k	1/16W	5%	RMC1/16 182JATP	J24185182	VER. A	92-	A	F2
R 1236	CHIP RES.	2.2k	1/16W	5%	RMC1/16 222JATP	J24185222	VER. D	92-	A	F2
R 1237	CHIP RES.	47k	1/16W	5%	RMC1/16 473JATP	J24185473		1-	B	g4
R 1238	CHIP RES.	47k	1/16W	5%	RMC1/16 473JATP	J24185473		1-	B	g3
R 1239	CHIP RES.	47k	1/16W	5%	RMC1/16 473JATP	J24185473		1-	B	g3
R 1240	CHIP RES.	47k	1/16W	5%	RMC1/16 473JATP	J24185473		1-	B	g3
R 1241	CHIP RES.	4.7k	1/16W	5%	RMC1/16 472JATP	J24185472		1-	B	b1
R 1242	CHIP RES.	4.7k	1/16W	5%	RMC1/16 472JATP	J24185472		1-	B	a2
R 1243	CHIP RES.	6.8k	1/16W	5%	RMC1/16 682JATP	J24185682		1-	A	F2
R 1244	CHIP RES.	15k	1/16W	5%	RMC1/16 153JATP	J24185153		1-	A	A1
R 1245	CHIP RES.	0	1/16W	5%	RMC1/16 000JATP	J24185000		1-	B	b1
R 1246	CHIP RES.	4.7k	1/16W	5%	RMC1/16 472JATP	J24185472		1-	B	g3
R 1247	CHIP RES.	10k	1/16W	5%	RMC1/16 103JATP	J24185103		1-3	B	b1
R 1247	CHIP RES.	2.2k	1/16W	5%	RMC1/16 222JATP	J24185222	VER. A	21-	B	b1
R 1247	CHIP RES.	10k	1/16W	5%	RMC1/16 103JATP	J24185103	VER. D	4-10	B	b1
R 1247	CHIP RES.	3.9k	1/16W	5%	RMC1/16 392JATP	J24185392	VER. D	11-	B	b1
R 1248	CHIP RES.	10k	1/16W	5%	RMC1/16 103JATP	J24185103		1-3	B	a1

MAIN Unit

Parts List

REF	DESCRIPTION	VALUE	V/W	TOL.	MFR'S DESIG	VXSTD P/N	VERS.	LOT	SIDE	LAY ADR
R 1248	CHIP RES.	2.2k	1/16W	5%	RMC1/16 222JATP	J24185222	VER. A	21-	B	a1
R 1248	CHIP RES.	10k	1/16W	5%	RMC1/16 103JATP	J24185103	VER. D	4-10	B	a1
R 1248	CHIP RES.	3.9k	1/16W	5%	RMC1/16 392JATP	J24185392	VER. D	11-	B	a1
R 1249	CHIP RES.	2.7k	1/16W	5%	RMC1/16 272JATP	J24185272		1-	B	g3
R 1250	CHIP RES.	10k	1/16W	5%	RMC1/16 103JATP	J24185103		1-	A	G1
R 1251	CHIP RES.	330	1/16W	5%	RMC1/16 331JATP	J24185331		1-20	A	A1
R 1251	CHIP RES.	330	1/16W	5%	RMC1/16 331JATP	J24185331	VER. D	21-	A	A1
R 1252	CHIP RES.	18	1/16W	5%	RMC1/16 180JATP	J24185180		1-20	A	A1
R 1252	CHIP RES.	18	1/16W	5%	RMC1/16 180JATP	J24185180	VER. D	21-	A	A1
R 1253	CHIP RES.	18k	1/16W	5%	RMC1/16 183JATP	J24185183		1-	A	G1
R 1254	CHIP RES.	12k	1/16W	5%	RMC1/16 123JATP	J24185123		1-	A	G1
R 1255	CHIP RES.	330	1/16W	5%	RMC1/16 331JATP	J24185331		1-20	A	A1
R 1255	CHIP RES.	330	1/16W	5%	RMC1/16 331JATP	J24185331	VER. D	21-	A	A1
R 1256	CHIP RES.	4.7k	1/16W	5%	RMC1/16 472JATP	J24185472		1-	A	F1
R 1257	CHIP RES.	47k	1/16W	5%	RMC1/16 473JATP	J24185473		1-	A	A3
R 1258	CHIP RES.	33k	1/16W	5%	RMC1/16 333JATP	J24185333		1-	A	A3
R 1259	CHIP RES.	56	1/16W	5%	RMC1/16 560JATP	J24185560		1-	A	G1
R 1260	CHIP RES.	100k	1/16W	5%	RMC1/16 104JATP	J24185104		1-	A	A3
R 1261	CHIP RES.	2.2k	1/16W	5%	RMC1/16 222JATP	J24185222		1-	A	E1
R 1262	CHIP RES.	10	1/16W	5%	RMC1/16 100JATP	J24185100		1-	A	E1
R 1263	CHIP RES.	10k	1/16W	5%	RMC1/16 103JATP	J24185103		1-	A	F1
R 1265	CHIP RES.	220	1/16W	5%	RMC1/16 221JATP	J24185221		1-	A	G1
R 1266	CHIP RES.	2.2k	1/16W	1%	RMC1/16 222FTP	J24183222		1-	A	B3
R 1267	CHIP RES.	100k	1/16W	5%	RMC1/16 104JATP	J24185104		1-	A	F1
R 1268	CHIP RES.	1.8k	1/16W	1%	RMC1/16 182FTP	J24183182		1-	A	A3
R 1269	CHIP RES.	100k	1/16W	5%	RMC1/16 104JATP	J24185104		1-	A	A3
R 1270	CHIP RES.	47	1/16W	5%	RMC1/16 470JATP	J24185470		1-	A	F4
R 1271	CHIP RES.	47	1/16W	5%	RMC1/16 470JATP	J24185470		1-	A	F3
R 1272	CHIP RES.	220	1/16W	5%	RMC1/16 221JATP	J24185221		1-22	A	F3
R 1272	CHIP RES.	220	1/16W	5%	RMC1/16 221JATP	J24185221	VER. D	23-	A	F3
R 1273	CHIP RES.	220	1/16W	5%	RMC1/16 221JATP	J24185221		1-22	A	F2
R 1273	CHIP RES.	330	1/16W	5%	RMC1/16 331JATP	J24185331	VER. A	23-	A	F2
R 1273	CHIP RES.	220	1/16W	5%	RMC1/16 221JATP	J24185221	VER. D	23-	A	F2
R 1274	CHIP RES.	33k	1/16W	5%	RMC1/16 333JATP	J24185333		1-	A	F1
R 1277	CHIP RES.	390	1/16W	5%	RMC1/16 391JATP	J24185391	VER. A	23-	A	F3
R 1280	CHIP RES.	0	1/16W	5%	RMC1/16 000JATP	J24185000		1-	A	G1
R 1281	CHIP RES.	15k	1/16W	5%	RMC1/16 153JATP	J24185153		1-22	B	f2
R 1281	CHIP RES.	1.5k	1/16W	5%	RMC1/16 152JATP	J24185152		23-	B	f2
R 1282	CHIP RES.	0	1/16W	5%	RMC1/16 000JATP	J24185000		1-	B	f2
R 1283	CHIP RES.	0	1/16W	5%	RMC1/16 000JATP	J24185000		1-	A	G1
R 1284	CHIP RES.	0	1/16W	5%	RMC1/16 000JATP	J24185000		1-	A	A2
R 1285	CHIP RES.	0	1/16W	5%	RMC1/16 000JATP	J24185000		1-	B	f2
R 1286	CHIP RES.	0	1/16W	5%	RMC1/16 000JATP	J24185000		1-	B	f2
R 1287	CHIP RES.	47	1/16W	5%	RMC1/16 470JATP	J24185470		1-	B	a1
R 1290	CHIP RES.	150	1/16W	5%	RMC1/16 151JATP	J24185151		1-	B	b2
R 1292	CHIP RES.	10k	1/16W	5%	RMC1/16 103JATP	J24185103		1-10	B	b2
R 1292	CHIP RES.	2.2k	1/16W	5%	RMC1/16 222JATP	J24185222		11-	B	b2
R 1293	CHIP RES.	0	1/16W	5%	RMC1/16 000JATP	J24185000		1-	B	b2
R 1294	CHIP RES.	2.7	1/10W	5%	RMC1/10T 2R7J	J24205279		1-	B	g2
R 1295	CHIP RES.	47	1/16W	5%	RMC1/16 470JATP	J24185470		1-	A	F3
R 1296	CHIP RES.	10k	1/16W	5%	RMC1/16 103JATP	J24185103		1-22	B	f2
R 1296	CHIP RES.	1k	1/16W	5%	RMC1/16 102JATP	J24185102		23-	B	f2
R 1298	CHIP RES.	4.7	1W	5%	RMC1 4R7JTE	J24305479		1-	B	g3
R 1299	CHIP RES.	4.7	1W	5%	RMC1 4R7JTE	J24305479		1-	B	g3
R 1300	CHIP RES.	100k	1/16W	5%	RMC1/16 104JATP	J24185104		1-	B	a2
R 1301	CHIP RES.	1k	1/16W	5%	RMC1/16 102JATP	J24185102		1-	A	G2
R 1302	CHIP RES.	1k	1/16W	5%	RMC1/16 102JATP	J24185102		1-	A	G2
R 1303	CHIP RES.	1k	1/16W	5%	RMC1/16 102JATP	J24185102		1-	A	G2
R 1304	CHIP RES.	0	1/16W	5%	RMC1/16 000JATP	J24185000		1-	B	b2
R 1305	CHIP RES.	3.3k	1/16W	5%	RMC1/16 332JATP	J24185332		1-	A	F3
R 1306	CHIP RES.	2.2k	1/16W	5%	RMC1/16 222JATP	J24185222		1-	A	F3
R 1307	CHIP RES.	18k	1/16W	5%	RMC1/16 183JATP	J24185183		1-	A	B4
R 1308	CHIP RES.	1k	1/16W	5%	RMC1/16 102JATP	J24185102		1-	B	f2
R 1309	CHIP RES.	270	1/10W	5%	RMC1/10T 271J	J24205271		1-	B	g2
R 1310	CHIP RES.	330	1/16W	5%	RMC1/16 331JATP	J24185331		1-	A	F3
R 1311	CHIP RES.	1k	1/16W	5%	RMC1/16 102JATP	J24185102		1-	B	f2
R 1312	CHIP RES.	0	1/16W	5%	RMC1/16 000JATP	J24185000		1-	B	b2
R 1313	CHIP RES.	1k	1/16W	5%	RMC1/16 102JATP	J24185102		1-	B	f2
R 1317	CHIP RES.	0	1/16W	5%	RMC1/16 000JATP	J24185000		1-	B	b2
R 1319	CHIP RES.	33k	1/16W	5%	RMC1/16 333JATP	J24185333		1-	A	B4
R 1320	CHIP RES.	1	1/10W	5%	RMC1/10T 1R0J	J24205010		1-	B	g2
R 1324	CHIP RES.	10	1/16W	5%	RMC1/16 100JATP	J24185100		1-	A	E2
R 1325	CHIP RES.	2.2k	1/16W	5%	RMC1/16 222JATP	J24185222		1-	A	E2

MAIN Unit

Parts List

REF	DESCRIPTION	VALUE	V/W	TOL.	MFR'S DESIG	VXSTD P/N	VERS.	LOT	SIDE	LAY ADR
R 1326	CHIP RES.	18	1/16W	5%	RMC1/16 180JATP	J24185180		1-	A	F2
R 1327	CHIP RES.	0	1/16W	5%	RMC1/16 000JATP	J24185000		1-	B	f2
R 1328	CHIP RES.	0	1/16W	5%	RMC1/16 000JATP	J24185000		1-	B	f2
R 1329	CHIP RES.	0	1/16W	5%	RMC1/16 000JATP	J24185000		1-	B	f2
R 1330	CHIP RES.	0	1/16W	5%	RMC1/16 000JATP	J24185000		1-	B	f2
R 1331	CHIP RES.	18	1/16W	5%	RMC1/16 180JATP	J24185180		1-	A	F3
R 1332	CHIP RES.	18	1/16W	5%	RMC1/16 180JATP	J24185180		1-	A	F2
R 1333	CHIP RES.	0	1W	5%	RMC1 JPATE	J24305000		1-	A	A4
R 1334	CHIP RES.	4.7k	1/16W	5%	RMC1/16 472JATP	J24185472		1-	A	B3
R 1336	CHIP RES.	2.2k	1/16W	5%	RMC1/16 222JATP	J24185222		1-	B	b1
R 1337	CHIP RES.	2.2k	1/16W	1%	RMC1/16 222FTP	J24183222		1-	A	B3
R 1338	CHIP RES.	0	1/10W	5%	RMC1/10T 000J	J24205000		1-	B	e4
R 1339	CHIP RES.	0	1/16W	5%	RMC1/16 000JATP	J24185000		1-	B	f3
R 1340	CHIP RES.	0	1/16W	5%	RMC1/16 000JATP	J24185000		1-	B	e3
R 1341	CHIP RES.	0	1/10W	5%	RMC1/10T 000J	J24205000		1-		
R 1342	CHIP RES.	0	1/10W	5%	RMC1/10T 000J	J24205000		1-2		
R 1343	CHIP RES.	0	1/16W	5%	RMC1/16 000JATP	J24185000		1-	B	f3
R 1344	CHIP RES.	0	1/16W	5%	RMC1/16 000JATP	J24185000		1-	B	f3
R 1345	CHIP RES.	100k	1/16W	5%	RMC1/16 104JATP	J24185104		1-	A	C4
R 1346	CHIP RES.	100k	1/16W	5%	RMC1/16 104JATP	J24185104		1-	A	C4
R 1347	CHIP RES.	100k	1/16W	5%	RMC1/16 104JATP	J24185104		1-	A	C4
R 1348	CHIP RES.	0	1/16W	5%	RMC1/16 000JATP	J24185000		1-	B	f3
R 1350	CHIP RES.	0	1/16W	5%	RMC1/16 000JATP	J24185000		1-2		
R 1351	CHIP RES.	1M	1/16W	5%	RMC1/16 105JATP	J24185105		1-20	A	C3
R 1351	CHIP RES.	220k	1/16W	1%	RMC1/16 224FTP	J24183224	VER. A	21-87	A	C3
R 1351	CHIP RES.	1M	1/16W	5%	RMC1/16 105JATP	J24185105	VER. A	88-	A	C3
R 1351	CHIP RES.	1M	1/16W	5%	RMC1/16 105JATP	J24185105	VER. D	21-	A	C3
R 1352	CARBON FILM RES.	2.2k	1/6W	5%	RD16PJ222 2.2K	J01225222		3-22	A	D3
R 1352	CHIP RES.	2.2k	1/16W	5%	RMC1/16 222JATP	J24185222	VER. A	23-24	A	D3
R 1352	CARBON FILM RES.	2.2k	1/6W	5%	RD16PJ222 2.2K	J01225222	VER. D	23-24	A	D3
R 1352	CHIP RES.	2.2k	1/16W	5%	RMC1/16 222JATP	J24185222		25-	A	D3
R 1353	CARBON FILM RES.	22k	1/6W	5%	RD16PJ223 22K	J01225223		11-22	A	B4
R 1353	CHIP RES.	22k	1/16W	5%	RMC1/16 223JATP	J24185223	VER. A	23-24	A	B4
R 1353	CARBON FILM RES.	22k	1/6W	5%	RD16PJ223 22K	J01225223	VER. D	23-24	A	B4
R 1353	CHIP RES.	22k	1/16W	5%	RMC1/16 223JATP	J24185223		25-	A	B4
R 1354	CHIP RES.	0	1/16W	5%	RMC1/16 000JATP	J24185000	VER. A	23-	A	C1
R 1501	CHIP RES.	10k	1/16W	5%	RMC1/16 103JATP	J24185103		3-15	B	c1
R 1501	CHIP RES.	1k	1/16W	5%	RMC1/16 102JATP	J24185102		16-22	B	c1
R 1501	CHIP RES.	2.7k	1/16W	5%	RMC1/16 272JATP	J24185272		23-	B	c1
R 1502	CHIP RES.	10k	1/16W	5%	RMC1/16 103JATP	J24185103		3-15	B	d1
R 1502	CHIP RES.	1k	1/16W	5%	RMC1/16 102JATP	J24185102		16-22	B	d1
R 1502	CHIP RES.	2.7k	1/16W	5%	RMC1/16 272JATP	J24185272		23-	B	d1
R 1503	CHIP RES.	390	1/16W	5%	RMC1/16 391JATP	J24185391	VER. A	23-24	B	c3
R 1503	CHIP RES.	390	1/16W	5%	RMC1/16 391JATP	J24185391		25-98	B	c3
R 1503	CHIP RES.	2.2k	1/16W	5%	RMC1/16 222JATP	J24185222		99-	B	c3
R 1504	CHIP RES.	390	1/16W	5%	RMC1/16 391JATP	J24185391	VER. A	23-24	B	c2
R 1504	CHIP RES.	390	1/16W	5%	RMC1/16 391JATP	J24185391		25-	B	c2
R 1505	CHIP RES.	390	1/16W	5%	RMC1/16 391JATP	J24185391	VER. A	23-24	B	c2
R 1505	CHIP RES.	390	1/16W	5%	RMC1/16 391JATP	J24185391		25-	B	c2
R 1507	CHIP RES.	100	1/16W	5%	RMC1/16 101JATP	J24185101		3-	B	c2
R 1508	CHIP RES.	180	1/16W	5%	RMC1/16 181JATP	J24185181		3-15	B	d2
R 1508	CHIP RES.	180	1/16W	5%	RMC1/16 181JATP	J24185181		16-22	B	d2
R 1508	CHIP RES.	100	1/16W	5%	RMC1/16 101JATP	J24185101	VER. A	23-24	B	d2
R 1508	CHIP RES.	100	1/16W	5%	RMC1/16 101JATP	J24185101		25-	B	d2
R 1509	CHIP RES.	68k	1/16W	5%	RMC1/16 683JATP	J24185683		3-	B	c2
R 1512	CHIP RES.	10k	1/16W	5%	RMC1/16 103JATP	J24185103		3-	B	c1
R 1513	CHIP RES.	150	1/16W	5%	RMC1/16 151JATP	J24185151		3-15	B	c2
R 1513	CHIP RES.	150	1/16W	5%	RMC1/16 151JATP	J24185151		16-22	B	c2
R 1513	CHIP RES.	100	1/16W	5%	RMC1/16 101JATP	J24185101	VER. A	23-24	B	c2
R 1513	CHIP RES.	100	1/16W	5%	RMC1/16 101JATP	J24185101		25-	B	c2
R 1514	CHIP RES.	100	1/16W	5%	RMC1/16 101JATP	J24185101	VER. A	23-24	B	c2
R 1514	CHIP RES.	100	1/16W	5%	RMC1/16 101JATP	J24185101		25-	B	c2
R 1515	CHIP RES.	150	1/16W	5%	RMC1/16 151JATP	J24185151		3-15	B	c1
R 1515	CHIP RES.	150	1/16W	5%	RMC1/16 151JATP	J24185151		16-22	B	c1
R 1515	CHIP RES.	100	1/16W	5%	RMC1/16 101JATP	J24185101	VER. A	23-24	B	c1
R 1515	CHIP RES.	100	1/16W	5%	RMC1/16 101JATP	J24185101		25-	B	c1
R 1516	CHIP RES.	390	1/16W	5%	RMC1/16 391JATP	J24185391	VER. A	23-24	B	c1
R 1516	CHIP RES.	390	1/16W	5%	RMC1/16 391JATP	J24185391		25-	B	c1
R 1517	CHIP RES.	390	1/16W	5%	RMC1/16 391JATP	J24185391	VER. A	23-24	B	c1
R 1517	CHIP RES.	390	1/16W	5%	RMC1/16 391JATP	J24185391		25-	B	c1
R 1518	CHIP RES.	390	1/16W	5%	RMC1/16 391JATP	J24185391	VER. A	23-24	B	c1
R 1518	CHIP RES.	390	1/16W	5%	RMC1/16 391JATP	J24185391		25-98	B	c1
R 1518	CHIP RES.	2.2k	1/16W	5%	RMC1/16 222JATP	J24185222		99-	B	c1

MAIN Unit

Parts List

REF	DESCRIPTION	VALUE	V/W	TOL.	MFR'S DESIG	VXSTD P/N	VERS.	LOT	SIDE	LAY ADR
R 1519	CHIP RES.	0	1/16W	5%	RMC1/16 000JATP	J24185000		3-15		
R 1519	CHIP RES.	0	1/16W	5%	RMC1/16 000JATP	J24185000		16-22		
R 1519	CHIP RES.	0	1/16W	5%	RMC1/16 000JATP	J24185000	VER. D	23-24		
R 1520	CHIP RES.	0	1/10W	5%	RMC1/10T 000J	J24205000		3-15		
R 1520	CHIP RES.	0	1/10W	5%	RMC1/10T 000J	J24205000		16-22		
R 1520	CHIP RES.	0	1/10W	5%	RMC1/10T 000J	J24205000	VER. D	23-24		
R 1521	CHIP RES.	0	1/10W	5%	RMC1/10T 000J	J24205000		3-		
R 1521	CHIP RES.	0	1/10W	5%	RMC1/10T 000J	J24205000		16-22		
R 1521	CHIP RES.	0	1/10W	5%	RMC1/10T 000J	J24205000	VER. D	23-24		
T 1001	COIL WIDE-TRANS.				3-317611	L0022478		1-	A	E4
T 1002	COIL WIDE-TRANS.				050812563 92H5	L0022479		1-	A	E3
T 1003	COIL WIDE-TRANS.				3-317611	L0022478		1-	A	E3
TC1001	TRIMMER CAP.	10pF			TC13C100C-TP03	K91000255		1-	A	G3
TC1002	TRIMMER CAP.	10pF			TC13C100C-TP03	K91000255		1-	A	G3
TH1001	THERMISTOR				157-502-53002TP	G9090049		1-	A	D4
TH1002	THERMISTOR				NTCG203SH223JT	G9090106		1-	A	C3
TH1003	THERMISTOR				157-502-53002TP	G9090049		1-	A	B4
TH1004	THERMISTOR				157-501-53009TP	G9090058		1-	A	C1
TP1001	TERMINAL				TP-K IPS-1136	Q5000050		1-	A	D2
TP1003	TERMINAL				TP-K IPS-1136	Q5000050		1-	A	F1
X 1001	XTAL OSC	14.4MHz			TTS12V 14.4MHZ	H9500650		1-	A	C3
X 1002	XTAL TSS-6035B	72.895MHz			72.895MHZ	H0103290		1-	A	E1
X 1003	XTAL OSC	14.4MHz			TTS12V 14.4MHZ	H9500650		1-	A	G1
XF1001	XTAL FILTER				TM7050A MF73P	H1102363		1-6	A	D2
XF1001	XTAL FILTER				TM7050A MF73P2	H1102381		7-	A	D2
XF1002	XTAL FILTER				TM7050A MF73P	H1102363		1-	A	D1
XF1501	XTAL FILTER				TM7050A MF73P	H1102363		3-15	B	c2
XF1501	XTAL FILTER				TM7050A MF73P	H1102363		16-22	B	c2
XF1501	XTAL FILTER				MFT73M 73.35MHZ	H1102391	VER. A	23-24	B	c2
XF1501	XTAL FILTER				MFT73M 73.35MHZ	H1102391		25-	B	c2
XF1502	XTAL FILTER				TM7050A MF73P	H1102363		3-15	B	c1
XF1502	XTAL FILTER				TM7050A MF73P	H1102363		16-22	B	c1
XF1502	XTAL FILTER				MFT73M 73.35MHZ	H1102391	VER. A	23-24	B	c1
XF1502	XTAL FILTER				MFT73M 73.35MHZ	H1102391		25-	B	c1
	SHIELD CASE				CASE-S7GDH	L9190016		1-5		
	SHIELD CASE				VCO	RA0014200		1-		
	SHIELD CASE				(A)	R0151950		1-		
	SHIELD CASE				(A)	RA0073900		1-		
	SHIELD CASE					RA0073900		1-		
	SHIELD CASE					RA0498300		1-		
	SHIELD CASE					RA0014300		1-		
	SHIELD CASE				(MIXER)	RA0439400		1-		
	LEAF SPRING					R0140031	VER. A	23-		
	LEAF SPRING					R0140031	VER. D	23-		

MAIN Unit

Note

AC044U CNTL-UNIT (3001-3899)

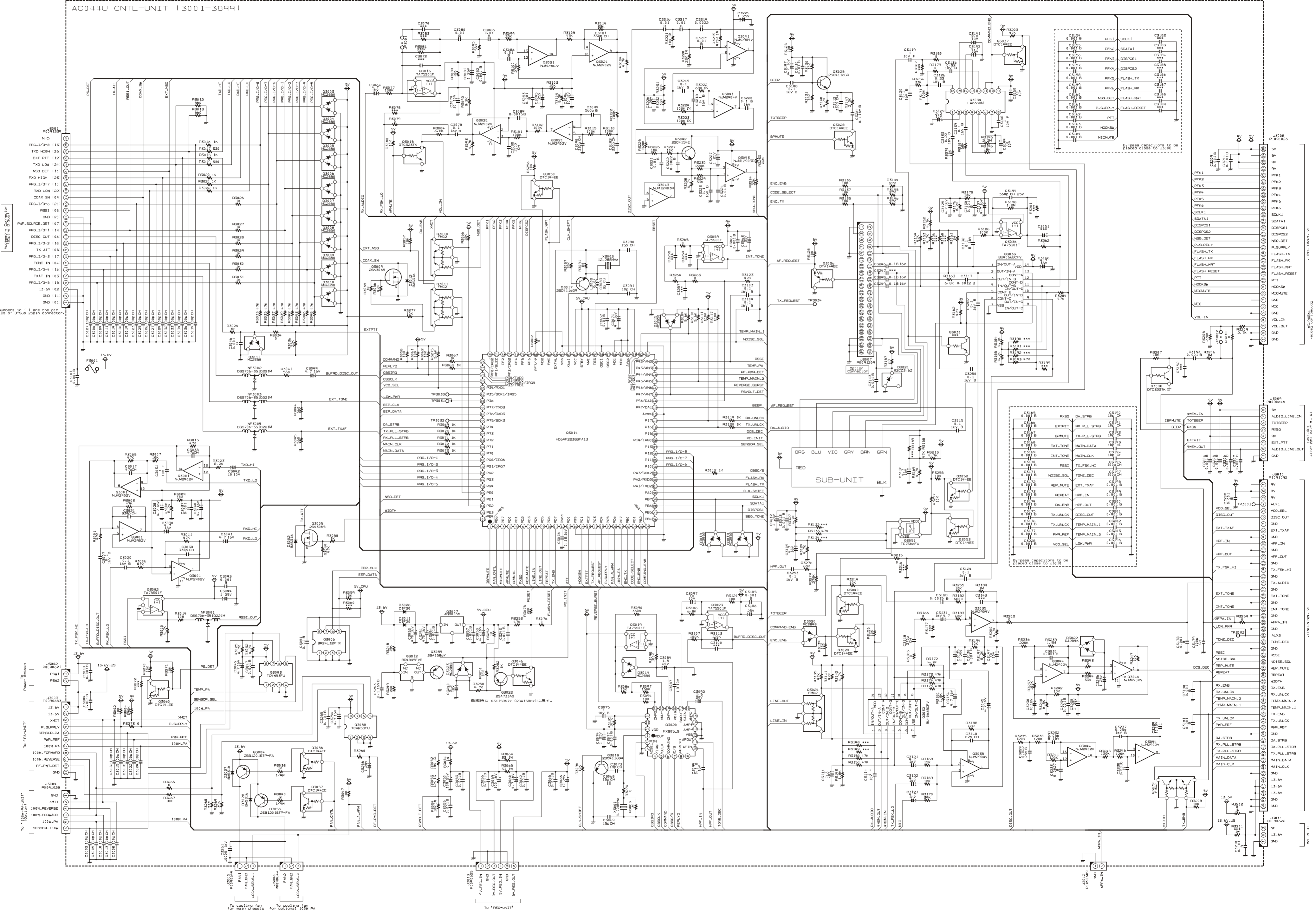

CNTL Unit (Lot. 1~2)

Note:

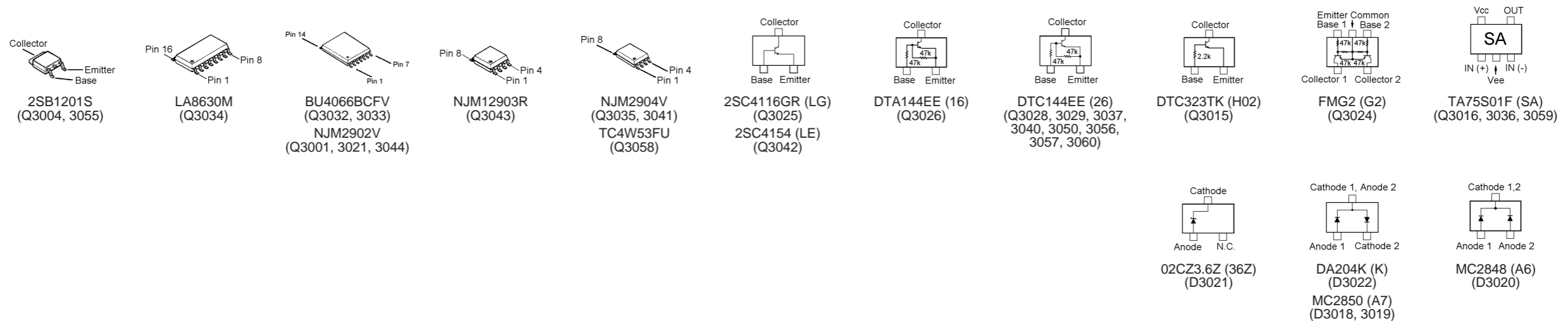
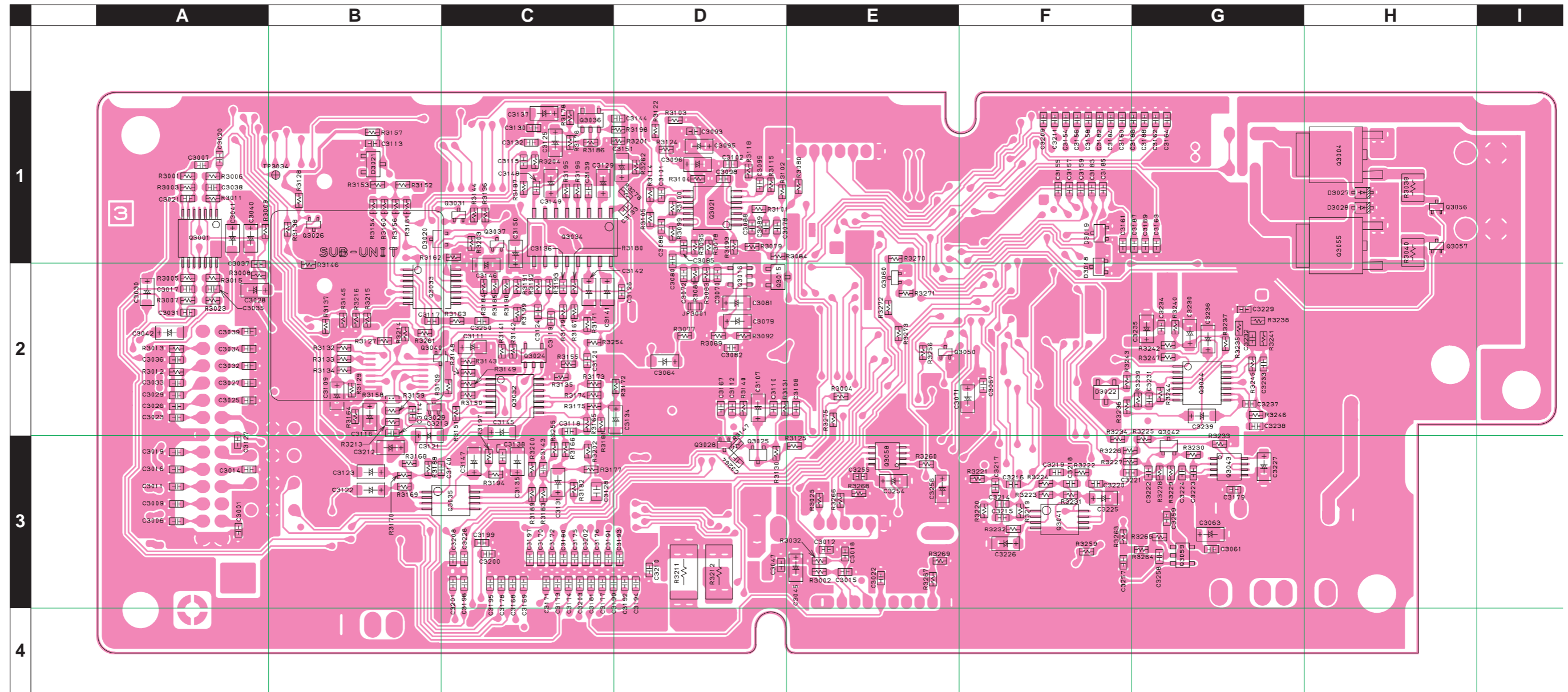

CNTL Unit (Lot. 1~2)

Parts Layout (Side B)

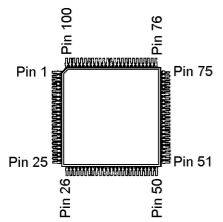
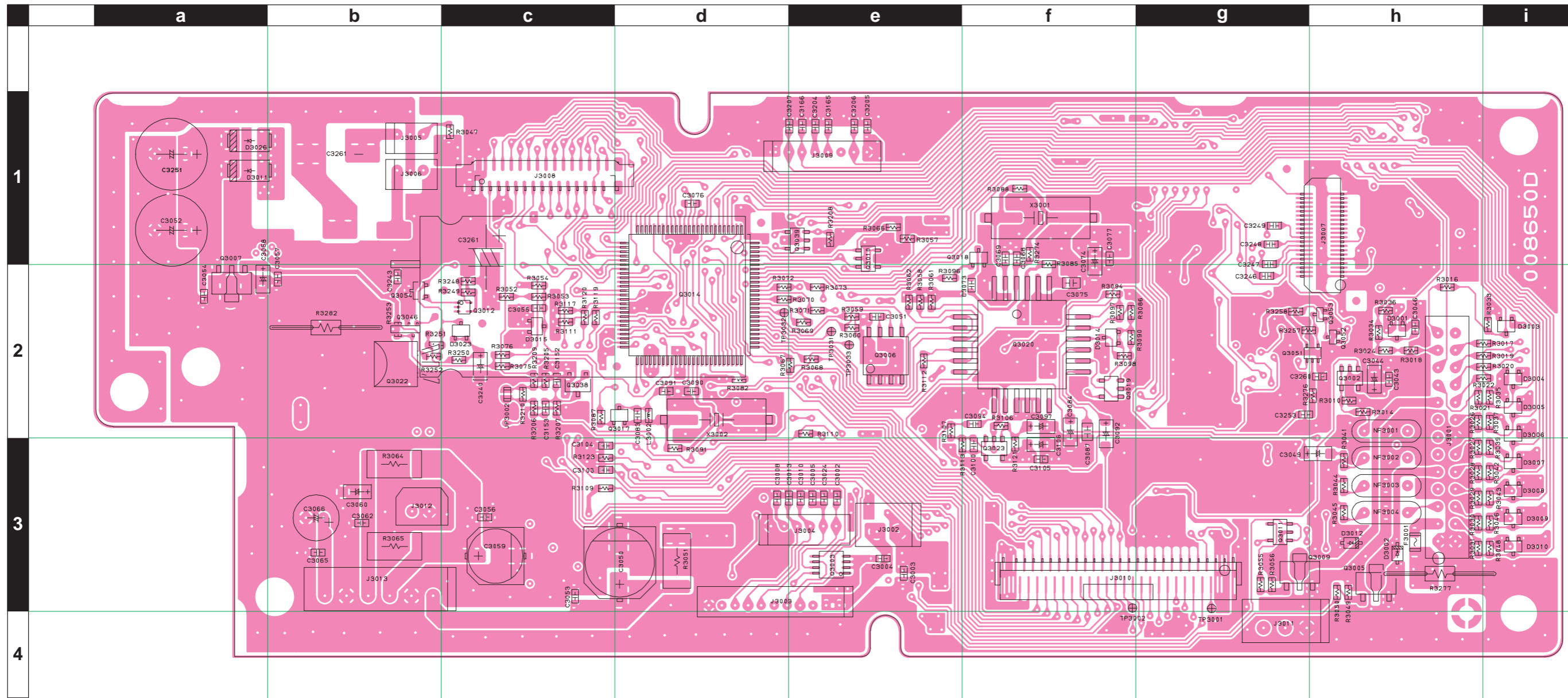

HD64F2238BFA (Q3014)

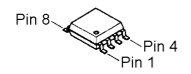

BR24L32F (Q3006)
TC4W53FU (Q3003)

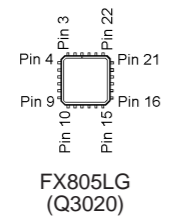

FX805LG (Q3020)

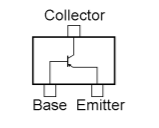

2SA1586Y (SY) (Q3054)

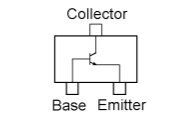

2SC4116GR (LG) (Q3017, 3018)

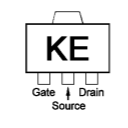

3SK3065 (LG) (Q3005, 3009)

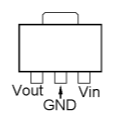

AN8005M (LG) (Q3007)

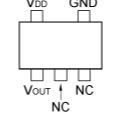

BD4845FVE (Q3012)

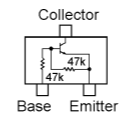

DTC144EE (26) (Q3046, 3052, 3053)

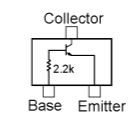

DTC323TK (H02) (Q3038)

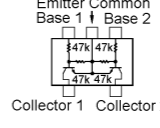

FMG2 (G2) (Q3010, 3011, 3039)

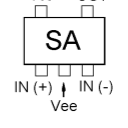

TA75S01F (SA) (Q3002, 3019, 3023)

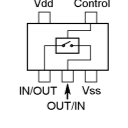

TC7S66FU (E9) (Q3051)

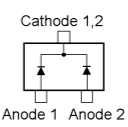

MC2848 (A6) (D3023)

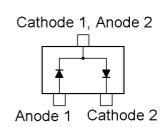

MC2850 (A7) (D3001, 3003, 3004, 3005, 3006, 3007, 3008, 3009, 3010, 3014, 3015)

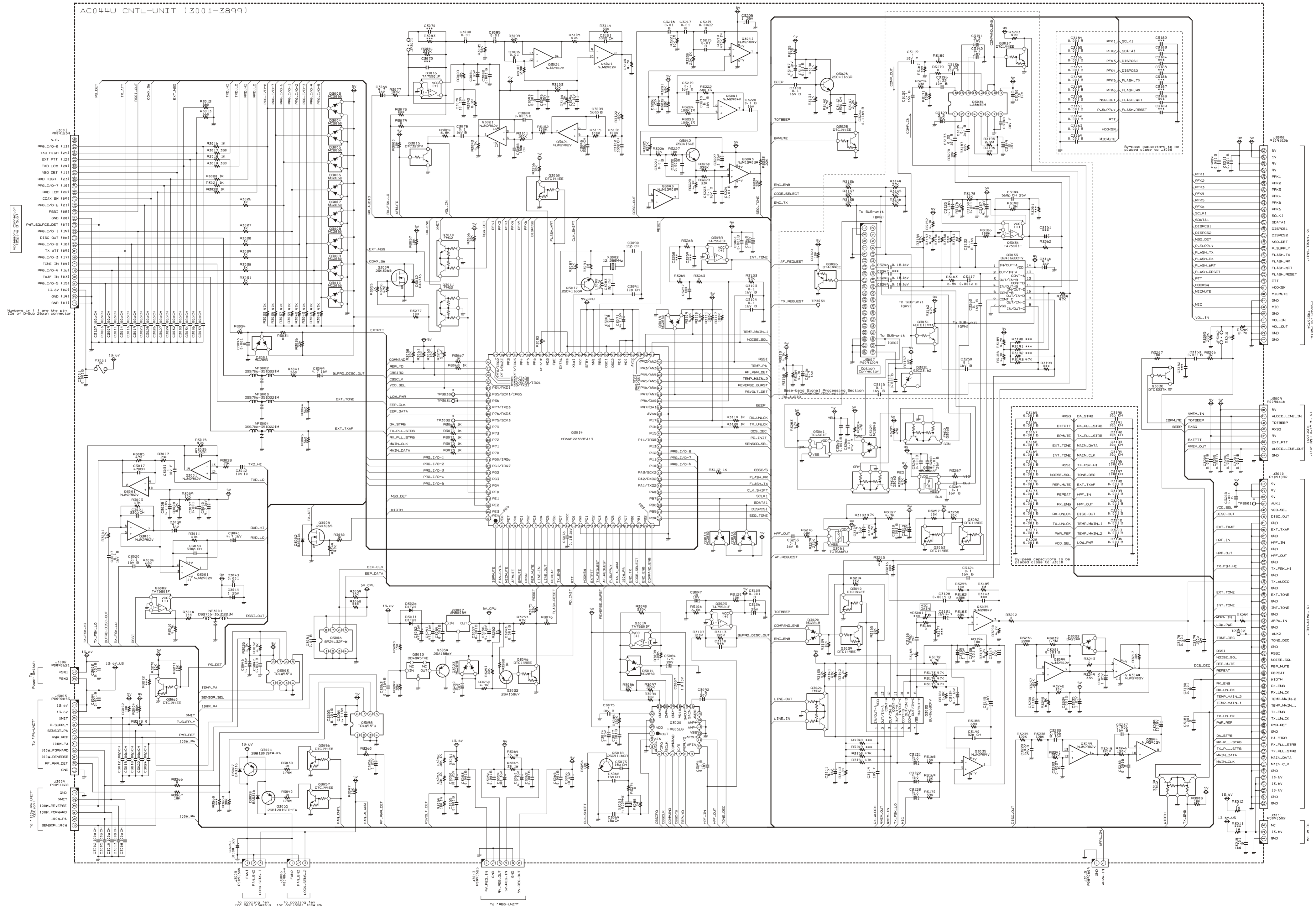

AC044U CNTL-UNIT (3001-3899)

Numbers in 1 are the pin nos of D-Sub 25pin connector.

To cooling fan for 100W PA, To cooling fan for 100W PA, To 'REG-UNIT'

CNTL Unit (Lot. 3~)

Note:

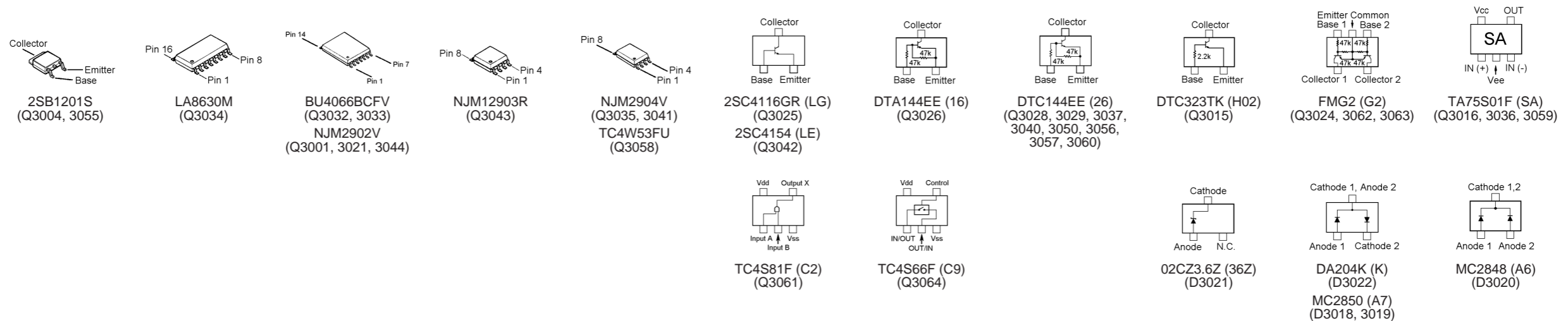
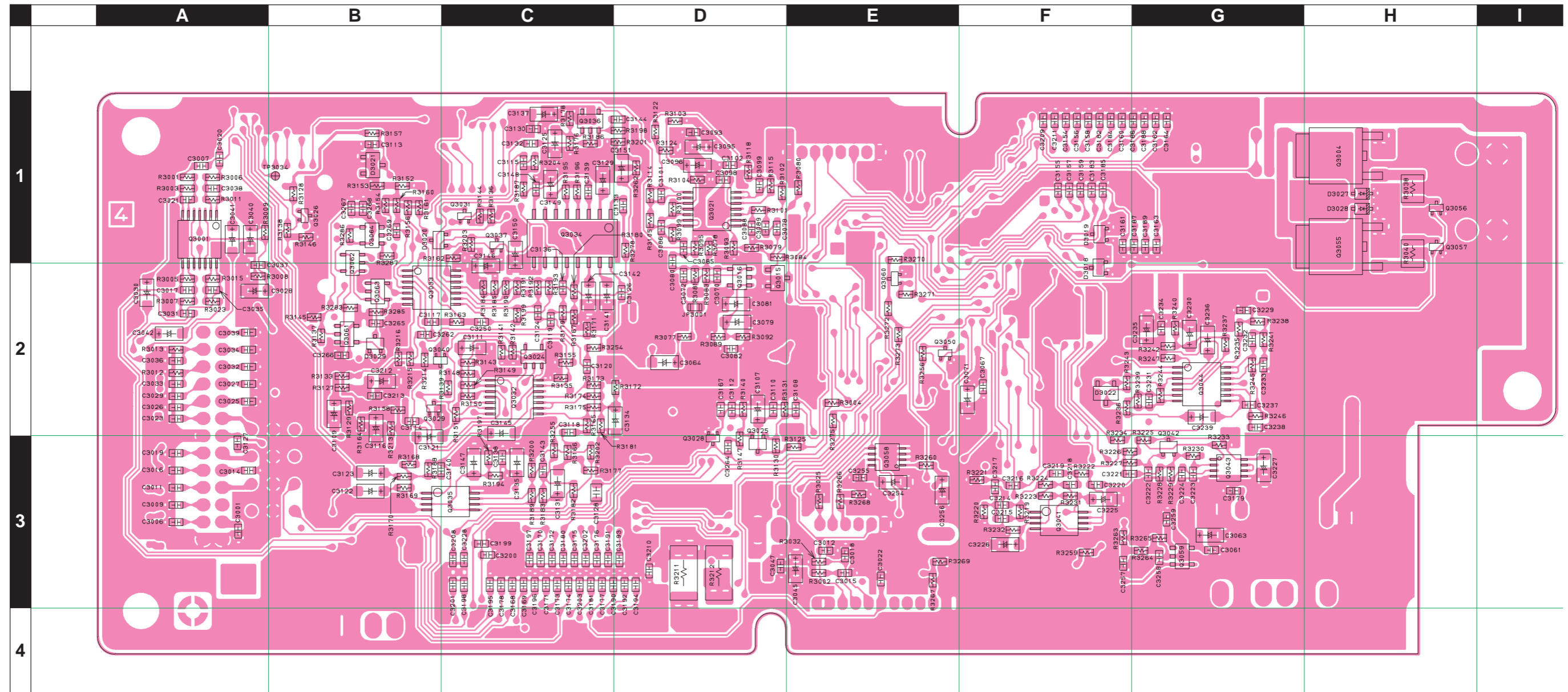

CNTL Unit (Lot. 3~)

Parts Layout (Side B)

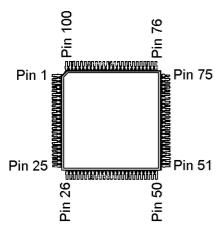
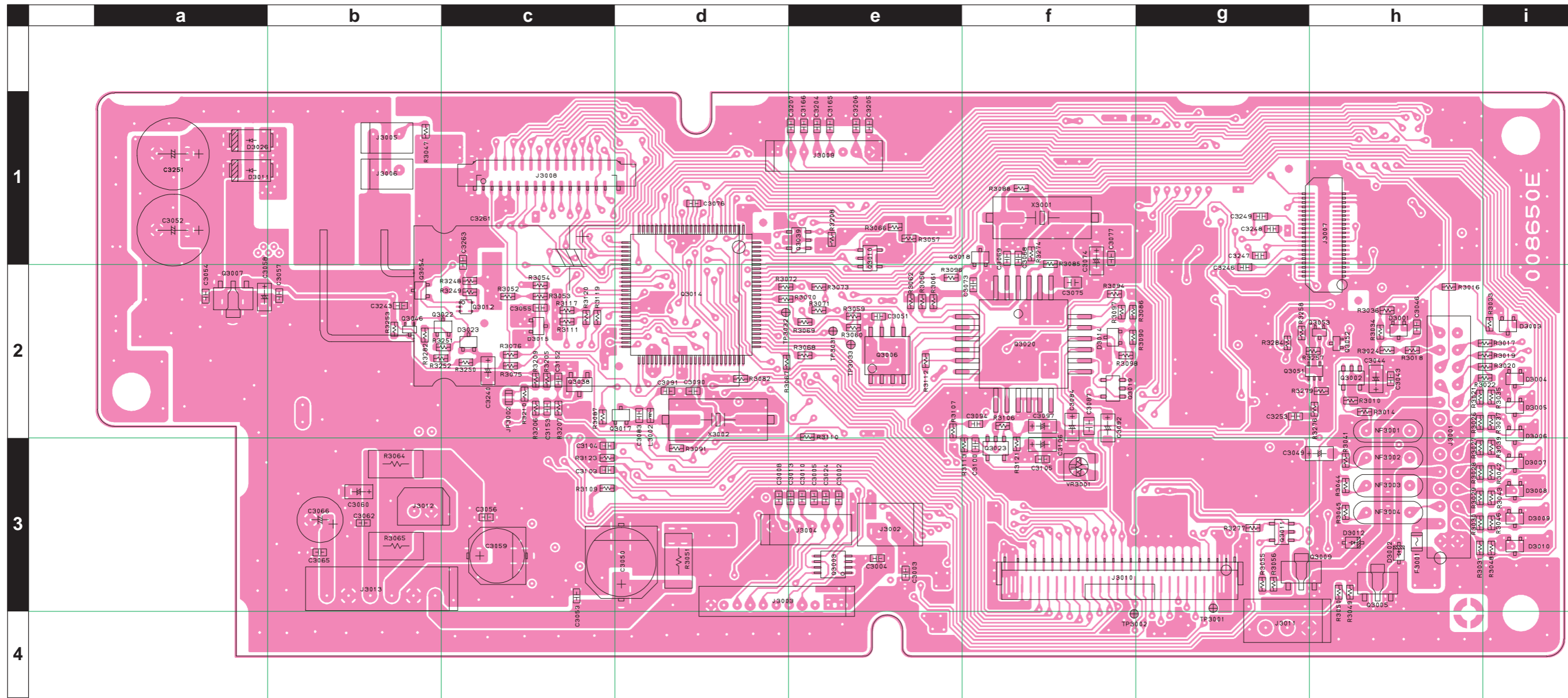

HD64F2238BFA
(Q3014)

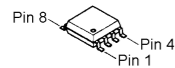

BR24L32F
(Q3006)
TC4W53FU
(Q3003)

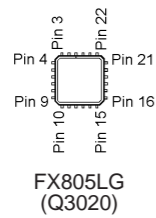

FX805LG
(Q3020)

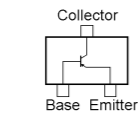

2SA1586Y (SY)
(Q3022, 3054)

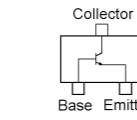

2SC4116GR (LG)
(Q3017, 3018)

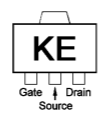

3SK3065 (LG)
(Q3005, 3009)

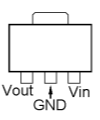

AN8005M (LG)
(Q3007)

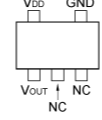

BD4845FVE
(Q3012)

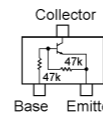

DTC144EE (26)
(Q3046, 3052, 3053)

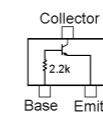

DTC323TK (H02)
(Q3038)

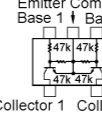

FMG2 (G2)
(Q3010, 3011, 3039)

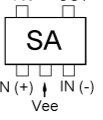

TA75S01F (SA)
(Q3002, 3019, 3023)

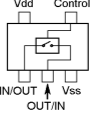

TC7S66FU (E9)
(Q3051)

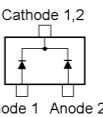

MC2848 (A6)
(D3023, 3029)

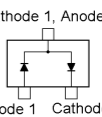

MC2850 (A7)
(D3001, 3003, 3004,
3005, 3006, 3007,
3008, 3009, 3010,
3014, 3015)

Parts List

REF	DESCRIPTION	VALUE	V/W	TOL.	MFR'S DESIG	VXSTD P/N	VERS.	LOT	SIDE	LAY ADR
PCB with Components						CS2257409	DST: USA	VER. A		
						CS2257410	DST: EXP	VER. A		
						CS2257411	DST: USA	VER. D		
						CS2257412	DST: EXP	VER. D		
						CS2257414	DST: AUS	VER. D		
C 3001	CHIP CAP.	0.001uF	50V	B	GRM188B11H102KA01D	K22174821		1-	A	A3
C 3002	CHIP CAP.	100pF	50V	CH	GRM1882C1H101JA01D	K22174235		1-	B	e3
C 3003	CHIP CAP.	0.001uF	50V	B	GRM188B11H102KA01D	K22174821		1-	B	e3
C 3004	CHIP CAP.	0.001uF	50V	B	GRM188B11H102KA01D	K22174821		1-	B	e3
C 3005	CHIP CAP.	100pF	50V	CH	GRM1882C1H101JA01D	K22174235		1-	B	e3
C 3006	CHIP CAP.	100pF	50V	CH	GRM1882C1H101JA01D	K22174235		1-	A	A3
C 3007	CHIP CAP.	0.1uF	16V	B	GRM188B11C104KA01D	K22124805		1-	A	A1
C 3008	CHIP CAP.	100pF	50V	CH	GRM1882C1H101JA01D	K22174235		1-	B	d3
C 3009	CHIP CAP.	100pF	50V	CH	GRM1882C1H101JA01D	K22174235		1-	A	A3
C 3010	CHIP CAP.	100pF	50V	CH	GRM1882C1H101JA01D	K22174235		1-	B	e3
C 3011	CHIP CAP.	100pF	50V	CH	GRM1882C1H101JA01D	K22174235		1-	A	A3
C 3012	CHIP CAP.	100pF	50V	CH	GRM1882C1H101JA01D	K22174235		1-	A	E3
C 3013	CHIP CAP.	100pF	50V	CH	GRM1882C1H101JA01D	K22174235		1-	B	d3
C 3014	CHIP CAP.	100pF	50V	CH	GRM1882C1H101JA01D	K22174235		1-	A	A3
C 3015	CHIP CAP.	100pF	50V	CH	GRM1882C1H101JA01D	K22174235		1-	A	E3
C 3016	CHIP CAP.	100pF	50V	CH	GRM1882C1H101JA01D	K22174235		1-	A	A3
C 3017	CHIP CAP.	47pF	50V	CH	GRM1882C1H470JA01D	K22174227		1-	A	A2
C 3018	CHIP CAP.	100pF	50V	CH	GRM1882C1H101JA01D	K22174235		1-	A	E3
C 3019	CHIP CAP.	100pF	50V	CH	GRM1882C1H101JA01D	K22174235		1-	A	A3
C 3020	CHIP CAP.	0.1uF	16V	B	GRM188B11C104KA01D	K22124805		1-	A	A1
C 3021	CHIP CAP.	330pF	50V	CH	GRM1882C1H331JA01D	K22174253		1-	A	A1
C 3022	CHIP CAP.	100pF	50V	CH	GRM1882C1H101JA01D	K22174235		1-	A	E3
C 3023	CHIP CAP.	100pF	50V	CH	GRM1882C1H101JA01D	K22174235		1-	A	A2
C 3024	CHIP CAP.	100pF	50V	CH	GRM1882C1H101JA01D	K22174235		1-	B	e3
C 3025	CHIP CAP.	100pF	50V	CH	GRM1882C1H101JA01D	K22174235		1-	A	A2
C 3026	CHIP CAP.	100pF	50V	CH	GRM1882C1H101JA01D	K22174235		1-	A	A2
C 3027	CHIP CAP.	100pF	50V	CH	GRM1882C1H101JA01D	K22174235		1-	A	A2
C 3028	CHIP TA.CAP.	4.7uF	16V		TEESVA1C475M8R	K78120031		1-	A	A2
C 3029	CHIP CAP.	100pF	50V	CH	GRM1882C1H101JA01D	K22174235		1-	A	A2
C 3030	CHIP TA.CAP.	4.7uF	16V		TEESVA1C475M8R	K78120031		1-	A	A2
C 3031	CHIP CAP.	1uF	10V	F	GRM188F11A105ZA01D	K22105001		1-	A	A2
C 3032	CHIP CAP.	100pF	50V	CH	GRM1882C1H101JA01D	K22174235		1-	A	A2
C 3033	CHIP CAP.	100pF	50V	CH	GRM1882C1H101JA01D	K22174235		1-	A	A2
C 3034	CHIP CAP.	100pF	50V	CH	GRM1882C1H101JA01D	K22174235		1-	A	A2
C 3035	CHIP CAP.	47pF	50V	CH	GRM1882C1H470JA01D	K22174227		1-	A	A2
C 3036	CHIP CAP.	100pF	50V	CH	GRM1882C1H101JA01D	K22174235		1-	A	A2
C 3037	CHIP CAP.	0.001uF	50V	B	GRM188B11H102KA01D	K22174821		1-	A	A1
C 3038	CHIP CAP.	330pF	50V	CH	GRM1882C1H331JA01D	K22174253		1-	A	A1
C 3039	CHIP CAP.	100pF	50V	CH	GRM1882C1H101JA01D	K22174235		1-	A	A2
C 3040	CHIP TA.CAP.	4.7uF	16V		TEESVA1C475M8R	K78120031		1-	A	A1
C 3041	CHIP TA.CAP.	4.7uF	16V		TEESVA1C475M8R	K78120031		1-	A	A1
C 3042	CHIP TA.CAP.	10uF	10V		TEESVA1A106M8R	K78100028		1-	A	A2
C 3043	CHIP CAP.	0.001uF	50V	B	GRM188B11H102KA01D	K22174821		1-	B	h2
C 3044	CHIP TA.CAP.	1uF	25V		TEESVA1E105M8R	K78140013		1-	B	h2
C 3045	CHIP TA.CAP.	4.7uF	16V		TEESVA1C475M8R	K78120031		1-	A	E3
C 3046	CHIP CAP.	0.001uF	50V	B	GRM188B11H102KA01D	K22174821		1-	B	h2
C 3047	CHIP CAP.	0.001uF	50V	B	GRM188B11H102KA01D	K22174821		1-	A	D3
C 3049	CHIP TA.CAP.	4.7uF	16V		TEESVA1C475M8R	K78120031		1-	B	h3
C 3050	AL.ELECTRO.CAP.	100uF	25V		ECEV1EA101UP	K48140013		1-24	B	d3
C 3050	AL.ELECTRO.CAP.	100uF	25V		EEE1EA101UP	K48140018		25-	B	d3
C 3051	CHIP CAP.	0.01uF	50V	B	GRM188B11H103KA01D	K22174823		1-	B	e2
C 3052	AL.ELECTRO.CAP.	470uF	16V		RE3-16V471MG3#	K40129066		1-	B	a1
C 3053	CHIP CAP.	0.001uF	50V	B	GRM188B11H102KA01D	K22174821		1-	B	c3
C 3054	CHIP CAP.	0.001uF	50V	B	GRM188B11H102KA01D	K22174821		1-	B	a2
C 3055	CHIP CAP.	0.001uF	50V	B	GRM188B11H102KA01D	K22174821		1-	B	c2
C 3056	CHIP CAP.	0.001uF	50V	B	GRM188B11H102KA01D	K22174821		1-	B	c3
C 3057	CHIP CAP.	0.001uF	50V	B	GRM188B11H102KA01D	K22174821		1-	B	b2
C 3058	CHIP TA.CAP.	4.7uF	16V		TEESVA1C475M8R	K78120031		1-	B	a2
C 3059	AL.ELECTRO.CAP.	100uF	16V		EEE1CA101WP	K48120012		1-	B	c3
C 3060	CHIP TA.CAP.	4.7uF	16V		TEESVA1C475M8R	K78120031		1-	B	b3
C 3061	CHIP CAP.	0.001uF	50V	B	GRM188B11H102KA01D	K22174821		1-	A	G3
C 3062	CHIP CAP.	0.001uF	50V	B	GRM188B11H102KA01D	K22174821		1-	B	b3
C 3063	CHIP TA.CAP.	1uF	25V		TEESVA1E105M8R	K78140013		1-	A	G3
C 3064	CHIP TA.CAP.	4.7uF	16V		TEESVA1C475M8R	K78120031		1-	A	D2
C 3065	CHIP CAP.	0.001uF	50V	B	GRM188B11H102KA01D	K22174821		1-	B	b3
C 3066	AL.ELECTRO.CAP.	10uF	25V		RC2-25V100ME1#	K40149012		1-	B	b3
C 3067	CHIP CAP.	0.01uF	50V	B	GRM188B11H103KA01D	K22174823		1-	A	F2
C 3068	CHIP CAP.	15pF	50V	CH	GRM1882C1H150JA01D	K22174215		1-	B	f1

CNTL Unit

Parts List

REF	DESCRIPTION	VALUE	V/W	TOL.	MFR'S DESIG	VXSTD P/N	VERS.	LOT	SIDE	LAY ADR
C 3069	CHIP CAP.	15pF	50V	CH	GRM1882C1H150JA01D	K22174215		1-	B	f1
C 3071	CHIP TA.CAP.	4.7uF	16V		TEESVA1C475M8R	K78120031		1-	A	F2
C 3073	CHIP CAP.	18pF	50V	CH	GRM1882C1H180JA01D	K22174217		1-	B	f2
C 3074	CHIP TA.CAP.	1uF	25V		TEESVA1E105M8R	K78140013		1-	B	f1
C 3075	CHIP CAP.	1uF	10V	B	GRM21BB11A105KA01L	K22100802		1-	B	f2
C 3076	CHIP CAP.	0.1uF	16V	B	GRM188B11C104KA01D	K22124805		1-	B	d1
C 3077	CHIP CAP.	0.001uF	50V	B	GRM188B11H102KA01D	K22174821		1-	B	f1
C 3078	CHIP CAP.	0.1uF	16V	B	GRM188B11C104KA01D	K22124805		1-	A	D1
C 3079	CHIP TA.CAP.	10uF	10V		TEESVA1A106M8R	K78100028		1-	A	D2
C 3080	CHIP CAP.	0.01uF	50V	B	GRM188B11H103KA01D	K22174823		1-	A	D1
C 3081	CHIP TA.CAP.	1uF	25V		TEESVA1E105M8R	K78140013		1-	A	D2
C 3082	CHIP CAP.	0.001uF	50V	B	GRM188B11H102KA01D	K22174821		1-	A	D2
C 3083	CHIP CAP.	3pF	50V	CJ	GRM1883C1H3R0CZ01D	K22174204		1-	B	d2
C 3084	CHIP TA.CAP.	1.5uF	20V		TEESVA1D155M8R	K78130013		1-	B	f2
C 3085	CHIP CAP.	0.01uF	50V	B	GRM188B11H103KA01D	K22174823		1-	A	D1
C 3086	CHIP CAP.	0.01uF	50V	B	GRM188B11H103KA01D	K22174823		1-	A	D1
C 3087	CHIP CAP.	1uF	10V	B	GRM21BB11A105KA01L	K22100802		1-	B	f2
C 3088	CHIP CAP.	150pF	50V	CH	GRM1882C1H151JA01D	K22174239		1-	A	D1
C 3089	CHIP CAP.	0.0015uF	50V	B	GRM188B11H152KA01D	K22174827		1-	A	D1
C 3090	CHIP CAP.	15pF	50V	CH	GRM1882C1H150JA01D	K22174215		1-	B	d2
C 3091	CHIP CAP.	10pF	50V	CH	GRM1882C1H100JA01D	K22174211		1-	B	d2
C 3092	CHIP TA.CAP.	1.5uF	20V		TEESVA1D155M8R	K78130013		1-	B	f2
C 3093	CHIP CAP.	0.001uF	50V	B	GRM188B11H102KA01D	K22174821		1-	A	D1
C 3094	CHIP CAP.	0.1uF	16V	B	GRM188B11C104KA01D	K22124805		1-	B	f2
C 3095	CHIP TA.CAP.	1uF	25V		TEESVA1E105M8R	K78140013		1-	A	D1
C 3096	CHIP TA.CAP.	10uF	10V		TEESVA1A106M8R	K78100028		1-	A	D1
C 3097	CHIP TA.CAP.	10uF	10V		TEESVA1A106M8R	K78100028		1-	B	f2
C 3098	CHIP CAP.	330pF	50V	CH	GRM1882C1H331JA01D	K22174253		1-22	A	D1
C 3098	CHIP CAP.	150pF	50V	CH	GRM1882C1H151JA01D	K22174239	VER A	23-	A	D1
C 3098	CHIP CAP.	330pF	50V	CH	GRM1882C1H331JA01D	K22174253	VER D	23-	A	D1
C 3099	CHIP CAP.	560pF	50V	B	ECUV1H561KBV	K22179611		1-68	A	D1
C 3099	CHIP CAP.	560pF	50V	B	GRM188B11H561KA01D	K22174806		69-	A	D1
C 3101	CHIP CAP.	330pF	50V	CH	GRM1882C1H331JA01D	K22174253		1-	A	D1
C 3102	CHIP CAP.	330pF	50V	CH	GRM1882C1H331JA01D	K22174253		1-	A	D1
C 3103	CHIP CAP.	0.1uF	16V	B	GRM188B11C104KA01D	K22124805		1-	B	c3
C 3104	CHIP CAP.	0.1uF	16V	B	GRM188B11C104KA01D	K22124805		1-	B	c3
C 3105	CHIP CAP.	0.001uF	50V	B	GRM188B11H102KA01D	K22174821		1-	B	f3
C 3106	CHIP TA.CAP.	1uF	25V		TEESVA1E105M8R	K78140013		1-	B	f3
C 3107	CHIP TA.CAP.	4.7uF	16V		TEESVA1C475M8R	K78120031		1-	A	D2
C 3108	CHIP CAP.	0.1uF	16V	B	GRM188B11C104KA01D	K22124805		1-	A	E2
C 3109	CHIP TA.CAP.	4.7uF	16V		TEESVA1C475M8R	K78120031		1-	A	B2
C 3110	CHIP CAP.	0.01uF	50V	B	GRM188B11H103KA01D	K22174823		1-	A	D2
C 3111	CHIP TA.CAP.	4.7uF	16V		TEESVA1C475M8R	K78120031		1-	A	C2
C 3112	CHIP CAP.	330pF	50V	CH	GRM1882C1H331JA01D	K22174253		1-	A	D2
C 3113	CHIP CAP.	0.001uF	50V	B	GRM188B11H102KA01D	K22174821		1-	A	B1
C 3114	CHIP CAP.	1uF	10V	F	GRM188F11A105ZA01D	K22105001		1-	A	B2
C 3115	CHIP CAP.	0.1uF	16V	B	GRM188B11C104KA01D	K22124805		1-	A	C1
C 3116	CHIP TA.CAP.	4.7uF	16V		TEESVA1C475M8R	K78120031		1-	A	B2
C 3117	CHIP CAP.	0.0012uF	50V	B	GRM188B11H122KA01D	K22174810		1-	A	B2
C 3118	CHIP CAP.	270pF	50V	CH	GRM1882C1H271JA01D	K22174251		1-	A	C2
C 3119	CHIP CAP.	1uF	10V	F	GRM188F11A105ZA01D	K22105001		1-	A	C2
C 3120	CHIP CAP.	0.1uF	16V	B	GRM188B11C104KA01D	K22124805		1-	A	C2
C 3121	CHIP TA.CAP.	4.7uF	16V		TEESVA1C475M8R	K78120031		1-	A	B2
C 3122	CHIP TA.CAP.	4.7uF	16V		TEESVA1C475M8R	K78120031		1-	A	B3
C 3123	CHIP TA.CAP.	4.7uF	16V		TEESVA1C475M8R	K78120031		1-	A	B3
C 3124	CHIP CAP.	0.1uF	16V	B	GRM188B11C104KA01D	K22124805		1-	A	C2
C 3125	CHIP TA.CAP.	4.7uF	16V		TEESVA1C475M8R	K78120031		1-	A	C1
C 3126	CHIP CAP.	0.22uF	10V	B	GRM188B11A224KA01D	K22104801		1-	A	D2
C 3127	CHIP CAP.	100pF	50V	CH	GRM1882C1H101JA01D	K22174235		1-	A	A3
C 3128	CHIP CAP.	0.0015uF	50V	B	GRM216B11H152KA01D	K22170807		1-	A	C3
C 3129	CHIP TA.CAP.	2.2uF	10V		TEESVA1A225M8R	K78100021		1-	A	C1
C 3130	CHIP CAP.	0.001uF	50V	B	GRM188B11H102KA01D	K22174821		1-	A	C1
C 3131	CHIP TA.CAP.	4.7uF	16V		TEESVA1C475M8R	K78120031		1-	A	C3
C 3132	CHIP CAP.	0.1uF	16V	B	GRM188B11C104KA01D	K22124805		1-	A	C1
C 3133	CHIP CAP.	0.22uF	10V	B	GRM188B11A224KA01D	K22104801		1-	A	D1
C 3134	CHIP TA.CAP.	4.7uF	16V		TEESVA1C475M8R	K78120031		1-	A	D2
C 3135	CHIP TA.CAP.	1uF	25V		TEESVA1E105M8R	K78140013		1-	A	C3
C 3136	CHIP CAP.	0.22uF	10V	B	GRM188B11A224KA01D	K22104801		1-	A	C2
C 3137	CHIP TA.CAP.	4.7uF	16V		TEESVA1C475M8R	K78120031		1-	A	C1
C 3138	CHIP CAP.	0.001uF	50V	B	GRM188B11H102KA01D	K22174821		1-	A	C3
C 3139	CHIP CAP.	0.1uF	16V	B	GRM188B11C104KA01D	K22124805		1-	A	C1
C 3140	CHIP CAP.	82pF	50V	CH	GRM1882C1H820JA01D	K22174233		1-	A	B3
C 3141	CHIP TA.CAP.	2.2uF	10V		TEESVA1A225M8R	K78100021		1-	A	C2

REF	DESCRIPTION	VALUE	V/W	TOL.	MFR'S DESIG	VXSTD P/N	VERS.	LOT	SIDE	LAY ADR
C 3142	CHIP TA.CAP.	4.7uF	16V		TEESVA1C475M8R	K78120031		1-	A	C2
C 3144	CHIP CAP.	560pF	25V	CH	GRM39CH561J25PT	K22144201		1-47	A	D1
C 3144	CHIP CAP.	560pF	50V	CH	GRM1882C1H561JA01D	K22174273		48-	A	D1
C 3145	CHIP TA.CAP.	4.7uF	16V		TEESVA1C475M8R	K78120031		1-	A	C2
C 3146	CHIP TA.CAP.	4.7uF	16V		TEESVA1C475M8R	K78120031		1-	A	C2
C 3147	CHIP TA.CAP.	10uF	10V		TEESVA1A106M8R	K78100028		1-	A	C3
C 3148	CHIP CAP.	1uF	10V	F	GRM188F11A105ZA01D	K22105001		1-	A	C1
C 3149	CHIP TA.CAP.	10uF	10V		TEESVA1A106M8R	K78100028		1-	A	C1
C 3150	CHIP TA.CAP.	10uF	10V		TEESVA1A106M8R	K78100028		1-	A	C1
C 3153	CHIP CAP.	0.001uF	50V	B	GRM188B11H102KA01D	K22174821		1-	B	c2
C 3154	CHIP CAP.	0.001uF	50V	B	GRM188B11H102KA01D	K22174821		1-	A	F1
C 3155	CHIP CAP.	0.001uF	50V	B	GRM188B11H102KA01D	K22174821		1-	A	F1
C 3156	CHIP CAP.	0.001uF	50V	B	GRM188B11H102KA01D	K22174821		1-	A	F1
C 3157	CHIP CAP.	0.001uF	50V	B	GRM188B11H102KA01D	K22174821		1-	A	F1
C 3158	CHIP CAP.	0.001uF	50V	B	GRM188B11H102KA01D	K22174821		1-	A	F1
C 3159	CHIP CAP.	0.001uF	50V	B	GRM188B11H102KA01D	K22174821		1-	A	F1
C 3160	CHIP CAP.	0.001uF	50V	B	GRM188B11H102KA01D	K22174821		1-	A	F1
C 3161	CHIP CAP.	0.001uF	50V	B	GRM188B11H102KA01D	K22174821		1-	A	F1
C 3162	CHIP CAP.	0.001uF	50V	B	GRM188B11H102KA01D	K22174821		1-	A	G1
C 3163	CHIP CAP.	0.001uF	50V	B	GRM188B11H102KA01D	K22174821		1-	A	G1
C 3164	CHIP CAP.	0.001uF	50V	B	GRM188B11H102KA01D	K22174821		1-	A	G1
C 3165	CHIP CAP.	0.001uF	50V	B	GRM188B11H102KA01D	K22174821		1-	B	e1
C 3166	CHIP CAP.	0.001uF	50V	B	GRM188B11H102KA01D	K22174821		1-	B	e1
C 3167	CHIP CAP.	0.001uF	50V	B	GRM188B11H102KA01D	K22174821		1-	A	D2
C 3168	CHIP CAP.	0.001uF	50V	B	GRM188B11H102KA01D	K22174821		1-	A	C3
C 3169	CHIP CAP.	0.001uF	50V	B	GRM188B11H102KA01D	K22174821		1-	A	C3
C 3170	CHIP CAP.	0.001uF	50V	B	GRM188B11H102KA01D	K22174821		1-	A	C3
C 3171	CHIP CAP.	0.001uF	50V	B	GRM188B11H102KA01D	K22174821		1-	A	C3
C 3172	CHIP CAP.	0.001uF	50V	B	GRM188B11H102KA01D	K22174821		1-	A	C3
C 3173	CHIP CAP.	0.001uF	50V	B	GRM188B11H102KA01D	K22174821		1-	A	C3
C 3174	CHIP CAP.	0.001uF	50V	B	GRM188B11H102KA01D	K22174821		1-	A	C3
C 3175	CHIP CAP.	0.001uF	50V	B	GRM188B11H102KA01D	K22174821		1-	A	C3
C 3176	CHIP CAP.	0.001uF	50V	B	GRM188B11H102KA01D	K22174821		1-	A	C3
C 3177	CHIP CAP.	0.001uF	50V	B	GRM188B11H102KA01D	K22174821		1-	A	C3
C 3178	CHIP CAP.	0.001uF	50V	B	GRM188B11H102KA01D	K22174821		1-	A	C3
C 3179	CHIP CAP.	100pF	50V	CH	GRM1882C1H101JA01D	K22174235		1-	A	G3
C 3180	CHIP CAP.	0.001uF	50V	B	GRM188B11H102KA01D	K22174821		1-	A	C3
C 3181	CHIP CAP.	0.001uF	50V	B	GRM188B11H102KA01D	K22174821		1-	A	C3
C 3190	CHIP CAP.	10pF	50V	CH	GRM1882C1H100JA01D	K22174211		1-	A	C3
C 3191	CHIP CAP.	10pF	50V	CH	GRM1882C1H100JA01D	K22174211		1-	A	C3
C 3192	CHIP CAP.	10pF	50V	CH	GRM1882C1H100JA01D	K22174211		1-	A	D3
C 3193	CHIP CAP.	10pF	50V	CH	GRM1882C1H100JA01D	K22174211		1-	A	D3
C 3194	CHIP CAP.	10pF	50V	CH	GRM1882C1H100JA01D	K22174211		1-	A	D3
C 3195	CHIP CAP.	100pF	50V	CH	GRM1882C1H101JA01D	K22174235		1-	A	C3
C 3196	CHIP CAP.	0.001uF	50V	B	GRM188B11H102KA01D	K22174821		1-	A	C3
C 3197	CHIP CAP.	100pF	50V	CH	GRM1882C1H101JA01D	K22174235		1-	A	C3
C 3198	CHIP CAP.	0.001uF	50V	B	GRM188B11H102KA01D	K22174821		1-	A	C3
C 3199	CHIP CAP.	0.001uF	50V	B	GRM188B11H102KA01D	K22174821		1-	A	C3
C 3200	CHIP CAP.	0.001uF	50V	B	GRM188B11H102KA01D	K22174821		1-	A	C3
C 3201	CHIP CAP.	0.001uF	50V	B	GRM188B11H102KA01D	K22174821		1-	A	C3
C 3202	CHIP CAP.	0.001uF	50V	B	GRM188B11H102KA01D	K22174821		1-	A	C3
C 3203	CHIP CAP.	0.001uF	50V	B	GRM188B11H102KA01D	K22174821		1-	A	C3
C 3204	CHIP CAP.	0.001uF	50V	B	GRM188B11H102KA01D	K22174821		1-	B	e1
C 3205	CHIP CAP.	0.001uF	50V	B	GRM188B11H102KA01D	K22174821		1-	B	e1
C 3206	CHIP CAP.	0.001uF	50V	B	GRM188B11H102KA01D	K22174821		1-	B	e1
C 3207	CHIP CAP.	0.001uF	50V	B	GRM188B11H102KA01D	K22174821		1-	B	d1
C 3208	CHIP CAP.	0.001uF	50V	B	GRM188B11H102KA01D	K22174821		1-	A	C3
C 3209	CHIP CAP.	0.001uF	50V	B	GRM188B11H102KA01D	K22174821		1-	A	F1
C 3210	CHIP CAP.	0.001uF	50V	B	GRM188B11H102KA01D	K22174821		1-	A	D3
C 3211	CHIP CAP.	0.001uF	50V	B	GRM188B11H102KA01D	K22174821		1-	A	F1
C 3212	CHIP TA.CAP.	1uF	25V		TEESVA1E105M8R	K78140013		1-	A	B2
C 3213	CHIP CAP.	0.001uF	50V	B	GRM188B11H102KA01D	K22174821		1-	A	B2
C 3214	CHIP CAP.	0.0022uF	50V	B	GRM188B11H222KA01D	K22174822		1-	A	F3
C 3215	CHIP CAP.	0.01uF	50V	B	GRM188B11H103KA01D	K22174823		1-	A	F3
C 3216	CHIP CAP.	0.01uF	50V	B	GRM188B11H103KA01D	K22174823		1-	A	F3
C 3217	CHIP CAP.	0.01uF	50V	B	GRM188B11H103KA01D	K22174823		1-	A	F3
C 3218	CHIP CAP.	0.1uF	16V	B	GRM188B11C104KA01D	K22124805		1-	A	F3
C 3219	CHIP CAP.	0.1uF	16V	B	GRM188B11C104KA01D	K22124805		1-	A	F3
C 3220	CHIP CAP.	0.1uF	16V	B	GRM188B11C104KA01D	K22124805		1-	A	F3
C 3221	CHIP CAP.	0.01uF	50V	B	GRM188B11H103KA01D	K22174823		1-	A	F3
C 3222	CHIP CAP.	0.0022uF	50V	B	GRM188B11H222KA01D	K22174822		1-	A	G3
C 3223	CHIP CAP.	0.1uF	16V	B	GRM188B11C104KA01D	K22124805		1-	A	G3
C 3224	CHIP CAP.	0.01uF	50V	B	GRM188B11H103KA01D	K22174823		1-	A	G3

CNTL Unit

Parts List

REF	DESCRIPTION	VALUE	V/W	TOL.	MFR'S DESIG	VXSTD P/N	VERS.	LOT	SIDE	LAY ADR
C 3225	CHIP TA.CAP.	1uF	25V		TEESVA1E105M8R	K78140013		1-	A	F3
C 3226	CHIP TA.CAP.	1uF	25V		TEESVA1E105M8R	K78140013		1-	A	F3
C 3227	CHIP TA.CAP.	1uF	25V		TEESVA1E105M8R	K78140013		1-	A	G3
C 3228	CHIP CAP.	0.001uF	50V	B	GRM188B11H102KA01D	K22174821		1-	A	C3
C 3229	CHIP CAP.	0.022uF	25V	B	GRM39B223K25PT	K22144807		1-47	A	G2
C 3229	CHIP CAP.	0.022uF	50V	B	GRM188B11H223KA01D	K22174839		48-	A	G2
C 3230	CHIP TA.CAP.	10uF	10V		TEESVA1A106M8R	K78100028		1-	A	G2
C 3231	CHIP CAP.	0.001uF	50V	B	GRM188B11H102KA01D	K22174821		1-	A	G2
C 3232	CHIP CAP.	0.056uF	16V	B	GRM188B11C563KA01D	K22124807		1-	A	G2
C 3233	CHIP CAP.	0.0027uF	50V	B	ECJ1VB1H272K	K22179619		1-85	A	G2
C 3233	CHIP CAP.	0.0027uF	50V	B	GRM188B11H272KA01D	K22174814		86-	A	G2
C 3234	CHIP CAP.	0.001uF	50V	B	GRM188B11H102KA01D	K22174821		1-	A	G2
C 3235	CHIP TA.CAP.	1uF	25V		TEESVA1E105M8R	K78140013		1-	A	G2
C 3236	CHIP TA.CAP.	1uF	25V		TEESVA1E105M8R	K78140013		1-	A	G2
C 3237	CHIP CAP.	0.056uF	16V	B	GRM188B11C563KA01D	K22124807		1-	A	G2
C 3238	CHIP CAP.	0.0018uF	50V	B	ECJ1VB1H182K	K22179617		1-80	A	G2
C 3238	CHIP CAP.	0.0018uF	50V	B	GRM188B11H182KA01D	K22174812		81-	A	G2
C 3239	CHIP TA.CAP.	10uF	10V		TEESVA1A106M8R	K78100028		1-	A	G2
C 3240	CHIP TA.CAP.	2.2uF	10V		TEESVA1A225M8R	K78100021		1-	B	c2
C 3243	CHIP CAP.	0.001uF	50V	B	GRM188B11H102KA01D	K22174821		1-	B	b2
C 3246	CHIP CAP.	0.1uF	16V	B	GRM188B11C104KA01D	K22124805		1-	B	g2
C 3248	CHIP CAP.	0.1uF	16V	B	GRM188B11C104KA01D	K22124805		1-	B	g1
C 3249	CHIP CAP.	0.1uF	16V	B	GRM188B11C104KA01D	K22124805		1-	B	g1
C 3250	CHIP CAP.	0.1uF	16V	B	GRM188B11C104KA01D	K22124805		1-	A	C2
C 3251	AL.ELECTRO.CAP.	470uF	16V		RE3-16V471MG3#	K40129066		1-	B	a1
C 3253	CHIP CAP.	0.1uF	16V	B	GRM188B11C104KA01D	K22124805		1-	B	g2
C 3254	CHIP TA.CAP.	4.7uF	16V		TEESVA1C475M8R	K78120031		1-	A	E3
C 3255	CHIP CAP.	0.001uF	50V	B	GRM188B11H102KA01D	K22174821		1-	A	E3
C 3256	CHIP TA.CAP.	1uF	25V		TEESVA1E105M8R	K78140013		1-	A	E3
C 3261	AL.ELECTRO.CAP.	10000uF	16V		RE3-16V103MK8#	K40129098		1-	B	b1
C 3262	CHIP CAP.	0.1uF	16V	B	GRM188B11C104KA01D	K22124805		1-	A	B2
C 3263	CHIP CAP.	0.1uF	16V	B	GRM188B11C104KA01D	K22124805		1-	B	c1
C 3264	CHIP CAP.	0.1uF	16V	B	GRM188B11C104KA01D	K22124805		1-	A	D3
C 3265	CHIP CAP.	0.001uF	50V	B	GRM188B11H102KA01D	K22174809		3-	A	B2
C 3266	CHIP CAP.	0.01uF	25V	B	GRM39B103M25PT	K22144802		3-47	A	B2
C 3266	CHIP CAP.	0.01uF	50V	B	GRM188B11H103KA01D	K22174823		48-	A	B2
C 3267	CHIP CAP.	0.001uF	50V	B	GRM188B11H102KA01D	K22174809		3-	A	B1
C 3268	CHIP CAP.	0.01uF	25V	B	GRM39B103M25PT	K22144802		3-47	A	B1
C 3268	CHIP CAP.	0.01uF	50V	B	GRM188B11H103KA01D	K22174823		48-	A	B1
C 3269	CHIP CAP.	0.1uF	16V	B	GRM188B11C104KA01D	K22124805		3-	A	B1
C 3270	CHIP CAP.	1uF	6.3V	B	GRM188B10J105KA01D	K22084801		4-		
D 3001	DIODE				MC2850-T111-1	G2070704		1-	B	h2
D 3002	DIODE				BAS316	G2070716		1-	B	h3
D 3003	DIODE				MC2850-T111-1	G2070704		1-	B	i2
D 3004	DIODE				MC2850-T111-1	G2070704		1-	B	i2
D 3005	DIODE				MC2850-T111-1	G2070704		1-	B	i2
D 3006	DIODE				MC2850-T111-1	G2070704		1-	B	i2
D 3007	DIODE				MC2850-T111-1	G2070704		1-	B	i3
D 3008	DIODE				MC2850-T111-1	G2070704		1-	B	i3
D 3009	DIODE				MC2850-T111-1	G2070704		1-	B	i3
D 3010	DIODE				MC2850-T111-1	G2070704		1-	B	i3
D 3011	DIODE				D1F20-5063	G2070474		1-51	B	a1
D 3011	DIODE				D1F60-5053	G2071240		52-	B	a1
D 3012	DIODE				BAS316	G2070716		1-	B	h3
D 3014	DIODE				MC2850-T111-1	G2070704		1-	B	f2
D 3015	DIODE				MC2850-T111-1	G2070704		1-	B	c2
D 3018	DIODE				MC2850-T111-1	G2070704		1-	A	F2
D 3019	DIODE				MC2850-T111-1	G2070704		1-	A	F1
D 3020	DIODE				MC2848-T111-1	G2070694		1-	A	B1
D 3021	DIODE				02CZ3.6Z TE85R	G2070164		1-	A	B1
D 3022	DIODE				DA204K T146	G2070388		1-	A	F2
D 3023	DIODE				MC2848-T111-1	G2070694		1-	B	c2
D 3026	DIODE				D1F20-5063	G2070474		1-51	B	a1
D 3026	DIODE				D1F60-5053	G2071240		52-	B	a1
D 3027	DIODE				BAS316	G2070716		1-	A	H1
D 3028	DIODE				BAS316	G2070716		1-	A	H1
D 3029	DIODE				MC2848-T111-1	G2070694		3-	A	B2
F 3001	CHIP FUSE	3A			F0805B3R00FWTR	Q0000082		53-62	B	h3
F 3001	CHIP FUSE	3.15A			FHC20 322ADTP	Q0000166		63-	B	h3
J 3001	CONNECTOR				B26B-PHDSS(LF)(SN)	P0091239		1-	B	h3
J 3002	CONNECTOR				SC25-02WS	P0090621		1-	B	e3
J 3003	CONNECTOR				IL-Y-11P-S15T2-E	P0090653		1-	B	e3
J 3004	CONNECTOR				IL-Y-6P-S15T2-EF	P0091028		1-	B	d3

CNTL Unit

Parts List

REF	DESCRIPTION	VALUE	V/W	TOL.	MFR'S DESIG	VXSTD P/N	VERS.	LOT	SIDE	LAY ADR
J 3005	CONNECTOR				IL-Y-3P-S15T2-EF	P0090644		1-	B	b1
J 3006	CONNECTOR				IL-Y-3P-S15T2-EF	P0090644		1-	B	b1
J 3007	CONNECTOR				AXK6S40535P	P0091209		1-	B	h1
J 3008	CONNECTOR				IL-FPR-30S-VFN1-R1500	P1091026		1-	B	c1
J 3009	CONNECTOR				IL-Y-8P-S15T2-EF	P0090646		1-	B	d1
J 3010	CONNECTOR				FH12-50S-0.5SV	P1091092		1-	B	f3
J 3011	CONNECTOR				SC25-03WS	P0090622		1-	B	g4
J 3012	CONNECTOR				SB20-02WS	P0090609		1-	B	b3
J 3013	CONNECTOR				SC25-06WS	P0090625		1-	B	b3
JP3001	WIRE ASSY				GRN 65 2/2	T50506500		1-2	A	D2
JP3003	WIRE ASSY				GRN 50 2/2	T50505000		4-		
L 3002	M.RFC	2.7uH			LK1608 2R7K-T	L1690848		1-	B	d2
NF3001	EMI FILTER				DSS706-351D221M25-50	Q9000642		1-	B	h2
NF3002	EMI FILTER				DSS706-351D221M25-50	Q9000642		1-	B	h3
NF3003	EMI FILTER				DSS706-351D221M25-50	Q9000642		1-	B	h3
NF3004	EMI FILTER				DSS706-351D221M25-50	Q9000642		1-	B	h3
P 3001	WIRE ASSY				BLK 80 FV2-M4/(5)	T9318204		1-		
Q 3001	IC				NJM2902V-TE1	G1091679		1-	A	A1
Q 3002	IC				TA75S01F(TE85R.F)	G1091593		1-	B	h2
Q 3003	IC				TC4W53FU(TE12L_F)	G1091675		1-	B	e3
Q 3004	TRANSISTOR				2SB1201S-TL	G3070195		1-	A	H1
Q 3005	FET				2SK3065 T100	G3830657		1-	B	h3
Q 3006	IC				BR24L32F-WE2	G1093913		1-	B	e2
Q 3007	IC				AN8005M-(E1)	G1091454		1-	B	a2
Q 3009	FET				2SK3065 T100	G3830657		1-	B	g3
Q 3010	TRANSISTOR				FMG2 T148	G3070015		1-	B	e1
Q 3011	TRANSISTOR				FMG2 T148	G3070015		1-	B	g3
Q 3012	IC				BD4845FVE-TR	G1093784		1-	B	c2
Q 3014	IC				HD64F2238BFA13(FLASH)	G1093757		1-	B	d2
Q 3015	TRANSISTOR				DTC323TK T146	G3070042		1-	A	D2
Q 3016	IC				TA75S01F(TE85R.F)	G1091593		1-	A	D2
Q 3017	TRANSISTOR				2SC4116GR(TE85R.F)	G3341167G		1-	B	d2
Q 3018	TRANSISTOR				2SC4116GR(TE85R.F)	G3341167G		1-	B	f1
Q 3019	IC				TA75S01F(TE85R.F)	G1091593		1-	B	f2
Q 3020	IC				FX805LG-TR	G1092528		1-	B	f2
Q 3021	IC				NJM2902V-TE1	G1091679		1-	A	D1
Q 3022	TRANSISTOR				2SA733AQ	G3107331Q		1-2	B	b2
Q 3022	TRANSISTOR				2SA1586Y(TE85R.F)	G3115867Y		3-	B	b2
Q 3023	IC				TA75S01F(TE85R.F)	G1091593		1-	B	f3
Q 3024	TRANSISTOR				FMG2 T148	G3070015		1-	A	C2
Q 3025	TRANSISTOR				2SC4116GR(TE85R.F)	G3341167G		1-	A	D3
Q 3026	TRANSISTOR				DTA144EE TL	G3070074		1-	A	B1
Q 3028	TRANSISTOR				DTC144EE TL	G3070075		1-	A	D3
Q 3029	TRANSISTOR				DTC144EE TL	G3070075		1-	A	B2
Q 3032	IC				BU4066BCFV-E2	G1093537		1-	A	C2
Q 3033	IC				BU4066BCFV-E2	G1093537		1-	A	B2
Q 3034	IC				LA8630M-B-TLM-E	G1093452		1-	A	C1
Q 3035	IC				NJM2904V-TE1	G1091677		1-	A	C3
Q 3036	IC				TA75S01F(TE85R.F)	G1091593		1-	A	C1
Q 3037	TRANSISTOR				DTC144EE TL	G3070075		1-	A	C1
Q 3038	TRANSISTOR				DTC323TK T146	G3070042		1-	B	c2
Q 3039	TRANSISTOR				FMG2 T148	G3070015		1-	B	e1
Q 3040	TRANSISTOR				DTC144EE TL	G3070075		1-	A	B2
Q 3041	IC				NJM2904V-TE1	G1091677		1-	A	F3
Q 3042	TRANSISTOR				2SC4154-T111-1E	G3341548E		1-	A	G3
Q 3043	IC				NJM12903R-TE1	G1093336		1-	A	G3
Q 3044	IC				NJM2902V-TE1	G1091679		1-	A	G2
Q 3046	TRANSISTOR				DTC144EE TL	G3070075		1-	B	b2
Q 3050	TRANSISTOR				DTC144EE TL	G3070075		1-	A	E2
Q 3051	IC				TC7S66FU(TE85R.F)	G1092116		1-	B	h2
Q 3052	TRANSISTOR				DTC144EE TL	G3070075		1-	B	h2
Q 3053	TRANSISTOR				DTC144EE TL	G3070075		1-	B	h2
Q 3054	TRANSISTOR				2SA1586Y(TE85R.F)	G3115867Y		1-	B	b2
Q 3055	TRANSISTOR				2SB1201S-TL	G3070195		1-	A	H1
Q 3056	TRANSISTOR				DTC144EE TL	G3070075		1-	A	H1
Q 3057	TRANSISTOR				DTC144EE TL	G3070075		1-	A	H1
Q 3058	IC				TC4W53FU(TE12L_F)	G1091675		1-	A	E3
Q 3059	IC				TA75S01F(TE85R.F)	G1091593		1-	A	G3
Q 3060	TRANSISTOR				DTC144EE TL	G3070075		1-	A	E2
Q 3061	IC				TC4S81F(TE85R.F)	G1090895		3-	A	B2
Q 3062	TRANSISTOR				FMG2 T148	G3070015		3-	A	B1
Q 3063	TRANSISTOR				FMG2 T148	G3070015		3-	A	B2
Q 3064	IC				TC4S66F(TE85R.F)	G1090893		3-	A	B1

CNTL Unit

Parts List

REF	DESCRIPTION	VALUE	V/W	TOL.	MFR'S DESIG	VXSTD P/N	VERS.	LOT	SIDE	LAY ADR
R 3001	CHIP RES.	47k	1/16W	5%	RMC1/16 473JATP	J24185473		1-	A	A1
R 3002	CHIP RES.	10k	1/16W	5%	RMC1/16 103JATP	J24185103		1-	A	E3
R 3003	CHIP RES.	47k	1/16W	5%	RMC1/16 473JATP	J24185473		1-	A	A1
R 3004	CHIP RES.	180k	1/16W	5%	RMC1/16 184JATP	J24185184		1-22	A	E2
R 3004	CHIP RES.	180k	1/16W	5%	RMC1/16 184JATP	J24185184		23-	A	E2
R 3005	CHIP RES.	47k	1/16W	5%	RMC1/16 473JATP	J24185473		1-	A	A2
R 3006	CHIP RES.	68k	1/16W	5%	RMC1/16 683JATP	J24185683		1-	A	A1
R 3007	CHIP RES.	15k	1/16W	5%	RMC1/16 153JATP	J24185153		1-	A	A2
R 3008	CHIP RES.	8.2k	1/16W	5%	RMC1/16 822JATP	J24185822		1-	A	A2
R 3009	CHIP RES.	10k	1/16W	5%	RMC1/16 103JATP	J24185103		1-	A	A1
R 3010	CHIP RES.	4.7k	1/16W	5%	RMC1/16 472JATP	J24185472		1-	B	h2
R 3011	CHIP RES.	47k	1/16W	5%	RMC1/16 473JATP	J24185473		1-	A	A1
R 3012	CHIP RES.	560	1/16W	5%	RMC1/16 561JATP	J24185561		1-	A	A2
R 3013	CHIP RES.	560	1/16W	5%	RMC1/16 561JATP	J24185561		1-	A	A2
R 3014	CHIP RES.	100	1/16W	5%	RMC1/16 101JATP	J24185101		1-	B	h2
R 3015	CHIP RES.	47k	1/16W	5%	RMC1/16 473JATP	J24185473		1-	A	A2
R 3016	CHIP RES.	1k	1/16W	5%	RMC1/16 102JATP	J24185102		1-	B	h2
R 3017	CHIP RES.	330	1/16W	5%	RMC1/16 331JATP	J24185331		1-	B	h2
R 3018	CHIP RES.	1k	1/16W	5%	RMC1/16 102JATP	J24185102		1-	B	h2
R 3019	CHIP RES.	330	1/16W	5%	RMC1/16 331JATP	J24185331		1-	B	h2
R 3020	CHIP RES.	1k	1/16W	5%	RMC1/16 102JATP	J24185102		1-	B	h2
R 3021	CHIP RES.	1k	1/16W	5%	RMC1/16 102JATP	J24185102		1-	B	h2
R 3022	CHIP RES.	1k	1/16W	5%	RMC1/16 102JATP	J24185102		1-	B	h2
R 3023	CHIP RES.	15k	1/16W	5%	RMC1/16 153JATP	J24185153		1-2	A	A2
R 3023	CHIP RES.	33k	1/16W	5%	RMC1/16 333JATP	J24185333		3-	A	A2
R 3024	CHIP RES.	1k	1/16W	5%	RMC1/16 102JATP	J24185102		1-	B	h2
R 3025	CHIP RES.	4.7k	1/16W	5%	RMC1/16 472JATP	J24185472		1-	A	E3
R 3026	CHIP RES.	1k	1/16W	5%	RMC1/16 102JATP	J24185102		1-	B	h2
R 3027	CHIP RES.	1k	1/16W	5%	RMC1/16 102JATP	J24185102		1-	B	h3
R 3028	CHIP RES.	1k	1/16W	5%	RMC1/16 102JATP	J24185102		1-	B	h3
R 3029	CHIP RES.	1k	1/16W	5%	RMC1/16 102JATP	J24185102		1-	B	h3
R 3030	CHIP RES.	1k	1/16W	5%	RMC1/16 102JATP	J24185102		1-	B	h3
R 3031	CHIP RES.	1k	1/16W	5%	RMC1/16 102JATP	J24185102		1-	B	h3
R 3032	CHIP RES.	4.7k	1/16W	5%	RMC1/16 472JATP	J24185472		1-	A	E3
R 3033	CHIP RES.	47k	1/16W	5%	RMC1/16 473JATP	J24185473		1-	B	i2
R 3034	CHIP RES.	0	1/16W	5%	RMC1/16 000JATP	J24185000		1-	B	h2
R 3035	CHIP RES.	47k	1/16W	5%	RMC1/16 473JATP	J24185473		1-	B	i2
R 3036	CHIP RES.	22k	1/16W	5%	RMC1/16 223JATP	J24185223		1-	B	h2
R 3037	CHIP RES.	47k	1/16W	5%	RMC1/16 473JATP	J24185473		1-	B	i2
R 3038	CHIP RES.	1k	1/4W	5%	RMC1/4 102JATP	J24245102		1-	A	H1
R 3039	CHIP RES.	47k	1/16W	5%	RMC1/16 473JATP	J24185473		1-	B	i3
R 3040	CHIP RES.	1k	1/4W	5%	RMC1/4 102JATP	J24245102		1-	A	H1
R 3041	CHIP RES.	560	1/16W	5%	RMC1/16 561JATP	J24185561		1-	B	h3
R 3042	CHIP RES.	47k	1/16W	5%	RMC1/16 473JATP	J24185473		1-	B	i3
R 3043	CHIP RES.	47k	1/16W	5%	RMC1/16 473JATP	J24185473		1-	B	i3
R 3045	CHIP RES.	560	1/16W	5%	RMC1/16 561JATP	J24185561		1-	B	h3
R 3046	CHIP RES.	47k	1/16W	5%	RMC1/16 473JATP	J24185473		1-	B	i3
R 3047	CHIP RES.	10k	1/16W	5%	RMC1/16 103JATP	J24185103		1-	B	b1
R 3048	CHIP RES.	47k	1/16W	5%	RMC1/16 473JATP	J24185473		1-	B	i3
R 3049	CHIP RES.	47k	1/16W	5%	RMC1/16 473JATP	J24185473		1-	B	h3
R 3050	CHIP RES.	1k	1/16W	5%	RMC1/16 102JATP	J24185102		1-	B	h3
R 3051	CHIP RES.	0	1W	5%	RMC1 JPATE	J24305000		1-	B	d3
R 3052	CHIP RES.	18k	1/16W	1%	RMC1/16 183FTP	J24183183		1-	B	c2
R 3053	CHIP RES.	12k	1/16W	1%	RMC1/16 123FTP	J24183123		1-	B	c2
R 3054	CHIP RES.	10k	1/16W	1%	RMC1/16 103FTP	J24183103		1-	B	c2
R 3055	CHIP RES.	1k	1/16W	5%	RMC1/16 102JATP	J24185102		1-29	B	g3
R 3056	CHIP RES.	47k	1/16W	5%	RMC1/16 473JATP	J24185473		1-	B	g3
R 3057	CHIP RES.	10k	1/16W	5%	RMC1/16 103JATP	J24185103		1-	B	e1
R 3058	CHIP RES.	10k	1/16W	5%	RMC1/16 103JATP	J24185103		1-	B	e2
R 3059	CHIP RES.	10k	1/16W	5%	RMC1/16 103JATP	J24185103		1-	B	e2
R 3061	CHIP RES.	10k	1/16W	5%	RMC1/16 103JATP	J24185103		1-	B	e2
R 3062	CHIP RES.	10k	1/16W	5%	RMC1/16 103JATP	J24185103		1-	B	e2
R 3064	CHIP RES.	33	1W	5%	RMC1 330JTE	J24305330		1-	B	b3
R 3065	CHIP RES.	33	1W	5%	RMC1 330JTE	J24305330		1-	B	b3
R 3066	CHIP RES.	10k	1/16W	5%	RMC1/16 103JATP	J24185103		1-	B	e1
R 3067	CHIP RES.	1k	1/16W	5%	RMC1/16 102JATP	J24185102		1-	B	d2
R 3068	CHIP RES.	1k	1/16W	5%	RMC1/16 102JATP	J24185102		1-	B	e2
R 3069	CHIP RES.	1k	1/16W	5%	RMC1/16 102JATP	J24185102		1-	B	e2
R 3070	CHIP RES.	1k	1/16W	5%	RMC1/16 102JATP	J24185102		1-	B	d2
R 3071	CHIP RES.	1k	1/16W	5%	RMC1/16 102JATP	J24185102		1-	B	e2
R 3072	CHIP RES.	1k	1/16W	5%	RMC1/16 102JATP	J24185102		1-	B	d2
R 3073	CHIP RES.	1k	1/16W	5%	RMC1/16 102JATP	J24185102		1-	B	e2
R 3075	CHIP RES.	22k	1/16W	5%	RMC1/16 223JATP	J24185223		1-	B	c2

REF	DESCRIPTION	VALUE	V/W	TOL.	MFR'S DESIG	VXSTD P/N	VERS.	LOT	SIDE	LAY ADR
R 3076	CHIP RES.	0	1/16W	5%	RMC1/16 000JATP	J24185000		1-	B	c2
R 3077	CHIP RES.	100k	1/16W	5%	RMC1/16 104JATP	J24185104		1-	A	D2
R 3079	CHIP RES.	0	1/16W	5%	RMC1/16 000JATP	J24185000		1-	A	D1
R 3080	CHIP RES.	10k	1/16W	5%	RMC1/16 103JATP	J24185103		1-	A	E1
R 3081	CHIP RES.	330k	1/16W	5%	RMC1/16 334JATP	J24185334		1-	A	D2
R 3082	CHIP RES.	0	1/16W	5%	RMC1/16 000JATP	J24185000		1-	B	d2
R 3084	CHIP RES.	6.8k	1/16W	5%	RMC1/16 682JATP	J24185682		1-	A	D1
R 3085	CHIP RES.	150k	1/16W	5%	RMC1/16 154JATP	J24185154		1-	B	f1
R 3086	CHIP RES.	10k	1/16W	5%	RMC1/16 103JATP	J24185103		1-	B	f2
R 3087	CHIP RES.	10k	1/16W	5%	RMC1/16 103JATP	J24185103		1-	B	c2
R 3088	CHIP RES.	1M	1/16W	5%	RMC1/16 105JATP	J24185105		1-	B	f1
R 3089	CHIP RES.	10k	1/16W	5%	RMC1/16 103JATP	J24185103		1-	A	D2
R 3090	CHIP RES.	330k	1/16W	5%	RMC1/16 334JATP	J24185334		1-	B	f2
R 3091	CHIP RES.	1M	1/16W	5%	RMC1/16 105JATP	J24185105		1-	B	d3
R 3092	CHIP RES.	8.2k	1/16W	5%	RMC1/16 822JATP	J24185822		1-	A	D2
R 3093	CHIP RES.	4.7k	1/16W	5%	RMC1/16 472JATP	J24185472		1-	A	D1
R 3094	CHIP RES.	10k	1/16W	5%	RMC1/16 103JATP	J24185103		1-	B	f2
R 3095	CHIP RES.	56k	1/16W	5%	RMC1/16 563JATP	J24185563		1-	A	D1
R 3096	CHIP RES.	10k	1/16W	5%	RMC1/16 103JATP	J24185103		1-	B	e2
R 3097	CHIP RES.	150k	1/16W	5%	RMC1/16 154JATP	J24185154		1-	B	f2
R 3098	CHIP RES.	100k	1/16W	5%	RMC1/16 104JATP	J24185104		1-	B	f2
R 3099	CHIP RES.	22k	1/16W	5%	RMC1/16 223JATP	J24185223		1-	A	D1
R 3100	CHIP RES.	270k	1/16W	5%	RMC1/16 274JATP	J24185274		1-	A	D1
R 3101	CHIP RES.	100k	1/16W	5%	RMC1/16 104JATP	J24185104		1-45	A	D1
R 3101	CHIP RES.	100k	1/16W	5%	RMC1/16 104JATP	J24185104	AUS	46-	A	D1
R 3101	CHIP RES.	100k	1/16W	5%	RMC1/16 104JATP	J24185104	EXP	46-	A	D1
R 3101	CHIP RES.	100k	1/16W	5%	RMC1/16 104JATP	J24185104	USA	46-	A	D1
R 3102	CHIP RES.	100k	1/16W	5%	RMC1/16 104JATP	J24185104		1-45	A	D1
R 3102	CHIP RES.	100k	1/16W	5%	RMC1/16 104JATP	J24185104	AUS	46-	A	D1
R 3102	CHIP RES.	100k	1/16W	5%	RMC1/16 104JATP	J24185104	EXP	46-	A	D1
R 3102	CHIP RES.	100k	1/16W	5%	RMC1/16 104JATP	J24185104	USA	46-	A	D1
R 3103	CHIP RES.	10k	1/16W	5%	RMC1/16 103JATP	J24185103		1-	A	D1
R 3104	CHIP RES.	8.2k	1/16W	5%	RMC1/16 822JATP	J24185822		1-	A	D1
R 3105	CHIP RES.	47k	1/16W	5%	RMC1/16 473JATP	J24185473		1-	A	D1
R 3106	CHIP RES.	6.8k	1/16W	5%	RMC1/16 682JATP	J24185682		1-	B	f2
R 3107	CHIP RES.	100k	1/16W	5%	RMC1/16 104JATP	J24185104		1-	B	e2
R 3109	CHIP RES.	5.6k	1/16W	5%	RMC1/16 562JATP	J24185562		1-	B	c3
R 3110	CHIP RES.	5.6k	1/16W	5%	RMC1/16 562JATP	J24185562		1-	B	e2
R 3111	CHIP RES.	100k	1/16W	5%	RMC1/16 104JATP	J24185104		1-	B	c2
R 3112	CHIP RES.	1k	1/16W	5%	RMC1/16 102JATP	J24185102		1-	B	e2
R 3113	CHIP RES.	120k	1/16W	5%	RMC1/16 124JATP	J24185124		1-	B	e3
R 3114	CHIP RES.	33k	1/16W	5%	RMC1/16 333JATP	J24185333		1-	A	D1
R 3115	CHIP RES.	100k	1/16W	5%	RMC1/16 104JATP	J24185104		1-45	A	D1
R 3115	CHIP RES.	100k	1/16W	5%	RMC1/16 104JATP	J24185104	AUS	46-	A	D1
R 3115	CHIP RES.	100k	1/16W	5%	RMC1/16 104JATP	J24185104	EXP	46-	A	D1
R 3115	CHIP RES.	100k	1/16W	5%	RMC1/16 104JATP	J24185104	USA	46-	A	D1
R 3117	CHIP RES.	100k	1/16W	5%	RMC1/16 104JATP	J24185104		1-	B	c2
R 3118	CHIP RES.	100k	1/16W	5%	RMC1/16 104JATP	J24185104		1-45	A	D1
R 3118	CHIP RES.	100k	1/16W	5%	RMC1/16 104JATP	J24185104	AUS	46-	A	D1
R 3118	CHIP RES.	100k	1/16W	5%	RMC1/16 104JATP	J24185104	EXP	46-	A	D1
R 3118	CHIP RES.	100k	1/16W	5%	RMC1/16 104JATP	J24185104	USA	46-	A	D1
R 3119	CHIP RES.	1k	1/16W	5%	RMC1/16 102JATP	J24185102		1-	B	c2
R 3120	CHIP RES.	1k	1/16W	5%	RMC1/16 102JATP	J24185102		1-	B	c2
R 3121	CHIP RES.	10k	1/16W	5%	RMC1/16 103JATP	J24185103		1-	B	f3
R 3122	CHIP RES.	100k	1/16W	5%	RMC1/16 104JATP	J24185104		1-45	A	D1
R 3122	CHIP RES.	100k	1/16W	5%	RMC1/16 104JATP	J24185104	AUS	46-	A	D1
R 3122	CHIP RES.	100k	1/16W	5%	RMC1/16 104JATP	J24185104	EXP	46-	A	D1
R 3122	CHIP RES.	100k	1/16W	5%	RMC1/16 104JATP	J24185104	USA	46-	A	D1
R 3123	CHIP RES.	47k	1/16W	5%	RMC1/16 473JATP	J24185473		1-	B	c3
R 3124	CHIP RES.	4.7k	1/16W	5%	RMC1/16 472JATP	J24185472		1-	A	D1
R 3125	CHIP RES.	100	1/16W	5%	RMC1/16 101JATP	J24185101		1-	A	E3
R 3127	CHIP RES.	4.7k	1/16W	5%	RMC1/16 472JATP	J24185472		1-	A	B2
R 3128	CHIP RES.	10k	1/16W	5%	RMC1/16 103JATP	J24185103		1-	A	B1
R 3129	CHIP RES.	4.7k	1/16W	5%	RMC1/16 472JATP	J24185472		1-	A	B2
R 3130	CHIP RES.	10k	1/16W	5%	RMC1/16 103JATP	J24185103		1-	A	D3
R 3131	CHIP RES.	10k	1/16W	5%	RMC1/16 103JATP	J24185103		1-	A	D2
R 3133	CHIP RES.	47k	1/16W	5%	RMC1/16 473JATP	J24185473		1-	A	B2
R 3135	CHIP RES.	47k	1/16W	5%	RMC1/16 473JATP	J24185473		1-	A	C2
R 3136	CHIP RES.	10k	1/16W	5%	RMC1/16 103JATP	J24185103		1-	A	C1
R 3137	CHIP RES.	10k	1/16W	5%	RMC1/16 103JATP	J24185103		1-	A	B2
R 3138	CHIP RES.	10k	1/16W	5%	RMC1/16 103JATP	J24185103		1-	A	B1
R 3139	CHIP RES.	10k	1/16W	5%	RMC1/16 103JATP	J24185103		1-	A	C2
R 3140	CHIP RES.	4.7k	1/16W	5%	RMC1/16 472JATP	J24185472		1-	A	D2

CNTL Unit

Parts List

REF	DESCRIPTION	VALUE	V/W	TOL.	MFR'S DESIG	VXSTD P/N	VERS.	LOT	SIDE	LAY ADR
R 3141	CHIP RES.	47k	1/16W	5%	RMC1/16 473JATP	J24185473		1-	A	C2
R 3142	CHIP RES.	4.7k	1/16W	5%	RMC1/16 472JATP	J24185472		1-	A	C2
R 3143	CHIP RES.	1.8k	1/16W	5%	RMC1/16 182JATP	J24185182		1-	A	C2
R 3144	CHIP RES.	27k	1/16W	5%	RMC1/16 273JATP	J24185273		1-	A	C1
R 3145	CHIP RES.	27k	1/16W	5%	RMC1/16 273JATP	J24185273		1-	A	B2
R 3146	CHIP RES.	27k	1/16W	5%	RMC1/16 273JATP	J24185273		1-	A	B1
R 3147	CHIP RES.	2.2k	1/16W	5%	RMC1/16 222JATP	J24185222		1-	A	D3
R 3150	CHIP RES.	47k	1/16W	5%	RMC1/16 473JATP	J24185473		1-	A	C2
R 3151	CHIP RES.	47k	1/16W	5%	RMC1/16 473JATP	J24185473		1-	A	C2
R 3152	CHIP RES.	4.7k	1/16W	5%	RMC1/16 472JATP	J24185472		1-	A	B1
R 3153	CHIP RES.	4.7k	1/16W	5%	RMC1/16 472JATP	J24185472		1-	A	B1
R 3154	CHIP RES.	47k	1/16W	5%	RMC1/16 473JATP	J24185473		1-	A	B1
R 3155	CHIP RES.	10k	1/16W	5%	RMC1/16 103JATP	J24185103		1-	A	C2
R 3157	CHIP RES.	68	1/16W	5%	RMC1/16 680JATP	J24185680		1-	A	B1
R 3158	CHIP RES.	1M	1/16W	5%	RMC1/16 105JATP	J24185105		1-	A	B2
R 3161	CHIP RES.	1M	1/16W	5%	RMC1/16 105JATP	J24185105		1-	A	B1
R 3162	CHIP RES.	47k	1/16W	5%	RMC1/16 473JATP	J24185473		1-	A	C1
R 3163	CHIP RES.	6.8k	1/16W	5%	RMC1/16 682JATP	J24185682		1-	A	C2
R 3164	CHIP RES.	4.7k	1/16W	5%	RMC1/16 472JATP	J24185472		1-	A	B2
R 3165	CHIP RES.	0	1/16W	5%	RMC1/16 000JATP	J24185000		1-	A	C2
R 3166	CHIP RES.	0	1/16W	5%	RMC1/16 000JATP	J24185000		1-	A	C3
R 3168	CHIP RES.	15k	1/16W	5%	RMC1/16 153JATP	J24185153		1-	A	B3
R 3169	CHIP RES.	10k	1/16W	5%	RMC1/16 103JATP	J24185103		1-	A	B3
R 3170	CHIP RES.	39k	1/16W	5%	RMC1/16 393JATP	J24185393		1-	A	B3
R 3171	CHIP RES.	100k	1/16W	5%	RMC1/16 104JATP	J24185104		1-	A	C2
R 3172	CHIP RES.	4.7k	1/16W	5%	RMC1/16 472JATP	J24185472		1-	A	D2
R 3173	CHIP RES.	47k	1/16W	5%	RMC1/16 473JATP	J24185473		1-	A	C2
R 3174	CHIP RES.	47k	1/16W	5%	RMC1/16 473JATP	J24185473		1-	A	C2
R 3175	CHIP RES.	47k	1/16W	5%	RMC1/16 473JATP	J24185473		1-	A	C2
R 3176	CHIP RES.	8.2k	1/16W	5%	RMC1/16 822JATP	J24185822		1-	A	C1
R 3178	CHIP RES.	10k	1/16W	5%	RMC1/16 103JATP	J24185103		1-	A	C1
R 3179	CHIP RES.	0	1/16W	5%	RMC1/16 000JATP	J24185000		1-	A	C2
R 3180	CHIP RES.	0	1/16W	5%	RMC1/16 000JATP	J24185000		1-	A	C2
R 3181	CHIP RES.	1.8k	1/16W	5%	RMC1/16 182JATP	J24185182		1-	A	C2
R 3182	CHIP RES.	680k	1/16W	5%	RMC1/16 684JATP	J24185684		1-	A	C3
R 3183	CHIP RES.	68k	1/16W	5%	RMC1/16 683JATP	J24185683		1-	A	C3
R 3184	CHIP RES.	4.7k	1/16W	5%	RMC1/16 472JATP	J24185472		1-	A	C2
R 3185	CHIP RES.	4.7k	1/16W	5%	RMC1/16 472JATP	J24185472		1-	A	C2
R 3186	CHIP RES.	100k	1/16W	5%	RMC1/16 104JATP	J24185104		1-	A	C1
R 3187	CHIP RES.	68k	1/16W	5%	RMC1/16 683JATP	J24185683		1-	A	C1
R 3188	CHIP RES.	68k	1/16W	5%	RMC1/16 683JATP	J24185683		1-	A	B3
R 3189	CHIP RES.	1M	1/16W	5%	RMC1/16 105JATP	J24185105		1-	A	C3
R 3193	CHIP RES.	47k	1/16W	5%	RMC1/16 473JATP	J24185473		1-	A	C2
R 3194	CHIP RES.	10k	1/16W	5%	RMC1/16 103JATP	J24185103		1-	A	C3
R 3195	CHIP RES.	2.2M	1/16W	5%	RMC1/16 225JATP	J24185225		1-	A	C1
R 3196	CHIP RES.	18k	1/16W	5%	RMC1/16 183JATP	J24185183		1-	A	C1
R 3197	CHIP RES.	8.2k	1/16W	5%	RMC1/16 822JATP	J24185822		1-	A	C3
R 3198	CHIP RES.	1.2M	1/16W	5%	RMC1/16 125JATP	J24185125		1-	A	D1
R 3200	CHIP RES.	4.7k	1/16W	5%	RMC1/16 472JATP	J24185472		1-	A	C3
R 3202	CHIP RES.	0	1/16W	5%	RMC1/16 000JATP	J24185000		1-	A	C3
R 3203	CHIP RES.	47k	1/16W	5%	RMC1/16 473JATP	J24185473		1-	A	C1
R 3204	CHIP RES.	47k	1/16W	5%	RMC1/16 473JATP	J24185473		1-	A	C1
R 3205	CHIP RES.	270k	1/16W	5%	RMC1/16 274JATP	J24185274		1-	B	c2
R 3206	CHIP RES.	1M	1/16W	5%	RMC1/16 105JATP	J24185105		1-	B	c2
R 3207	CHIP RES.	10k	1/16W	5%	RMC1/16 103JATP	J24185103		1-	B	c2
R 3208	CHIP RES.	10k	1/16W	5%	RMC1/16 103JATP	J24185103		1-	B	e1
R 3209	CHIP RES.	2.7k	1/16W	5%	RMC1/16 272JATP	J24185272		1-	B	c2
R 3210	CHIP RES.	0	1/16W	5%	RMC1/16 000JATP	J24185000		1-	B	c2
R 3212	CHIP RES.	0	1W	5%	RMC1 JPATE	J24305000		1-	A	D3
R 3213	CHIP RES.	4.7k	1/16W	5%	RMC1/16 472JATP	J24185472		1-	A	B2
R 3214	CHIP RES.	10k	1/16W	5%	RMC1/16 103JATP	J24185103		1-	A	B2
R 3215	CHIP RES.	0	1/16W	5%	RMC1/16 000JATP	J24185000		1-	A	B2
R 3219	CHIP RES.	470k	1/16W	1%	RMC1/16 474FTP	J24183474		1-	A	F3
R 3220	CHIP RES.	22k	1/16W	1%	RMC1/16 223FTP	J24183223		1-	A	F3
R 3221	CHIP RES.	10k	1/16W	1%	RMC1/16 103FTP	J24183103		1-	A	F3
R 3222	CHIP RES.	680	1/16W	1%	RMC1/16 681FTP	J24183681		1-	A	F3
R 3223	CHIP RES.	100k	1/16W	1%	RMC1/16 104FTP	J24183104		1-	A	F3
R 3224	CHIP RES.	100k	1/16W	1%	RMC1/16 104FTP	J24183104		1-	A	F3
R 3225	CHIP RES.	820k	1/16W	5%	RMC1/16 824JATP	J24185824		1-	A	G3
R 3226	CHIP RES.	10k	1/16W	5%	RMC1/16 103JATP	J24185103		1-	A	F3
R 3227	CHIP RES.	10k	1/16W	5%	RMC1/16 103JATP	J24185103		1-	A	F3
R 3228	CHIP RES.	4.7k	1/16W	5%	RMC1/16 472JATP	J24185472		1-	A	G3
R 3229	CHIP RES.	33k	1/16W	5%	RMC1/16 333JATP	J24185333		1-	A	G3

REF	DESCRIPTION	VALUE	V/W	TOL.	MFR'S DESIG	VXSTD P/N	VERS.	LOT	SIDE	LAY ADR
R 3230	CHIP RES.	220k	1/16W	5%	RMC1/16 224JATP	J24185224		1-	A	G3
R 3231	CHIP RES.	68k	1/16W	5%	RMC1/16 683JATP	J24185683		1-	A	F3
R 3232	CHIP RES.	33k	1/16W	5%	RMC1/16 333JATP	J24185333		1-	A	F3
R 3233	CHIP RES.	22k	1/16W	5%	RMC1/16 223JATP	J24185223		1-	A	G3
R 3234	CHIP RES.	22k	1/16W	5%	RMC1/16 223JATP	J24185223		1-	A	F3
R 3235	CHIP RES.	120k	1/16W	5%	RMC1/16 124JATP	J24185124		1-	A	G2
R 3236	CHIP RES.	220k	1/16W	5%	RMC1/16 224JATP	J24185224		1-	A	F2
R 3237	CHIP RES.	100k	1/16W	5%	RMC1/16 104JATP	J24185104		1-	A	G2
R 3238	CHIP RES.	120k	1/16W	5%	RMC1/16 124JATP	J24185124		1-	A	G2
R 3239	CHIP RES.	1.5M	1/16W	5%	RMC1/16 155JATP	J24185155		1-	A	G2
R 3240	CHIP RES.	6.8k	1/16W	5%	RMC1/16 682JATP	J24185682		1-	A	G2
R 3241	CHIP RES.	120k	1/16W	5%	RMC1/16 124JATP	J24185124		1-	A	G2
R 3242	CHIP RES.	10k	1/16W	5%	RMC1/16 103JATP	J24185103		1-	A	G2
R 3243	CHIP RES.	0	1/16W	5%	RMC1/16 000JATP	J24185000		1-	A	F2
R 3244	CHIP RES.	33k	1/16W	5%	RMC1/16 333JATP	J24185333		1-	A	G2
R 3245	CHIP RES.	120k	1/16W	5%	RMC1/16 124JATP	J24185124		1-	A	G2
R 3246	CHIP RES.	120k	1/16W	5%	RMC1/16 124JATP	J24185124		1-	A	G2
R 3247	CHIP RES.	10k	1/16W	5%	RMC1/16 103JATP	J24185103		1-	A	G2
R 3248	CHIP RES.	15k	1/16W	5%	RMC1/16 153JATP	J24185153		1-	B	c2
R 3249	CHIP RES.	22k	1/16W	5%	RMC1/16 223JATP	J24185223		1-	B	c2
R 3250	CHIP RES.	4.7k	1/16W	5%	RMC1/16 472JATP	J24185472		1-	B	c2
R 3251	CHIP RES.	10k	1/16W	5%	RMC1/16 103JATP	J24185103		1-	B	b2
R 3252	CHIP RES.	1k	1/16W	5%	RMC1/16 102JATP	J24185102		1-	B	b2
R 3253	CHIP RES.	47k	1/16W	5%	RMC1/16 473JATP	J24185473		1-	B	b2
R 3254	CHIP RES.	33k	1/16W	5%	RMC1/16 333JATP	J24185333		1-	A	C2
R 3255	CHIP RES.	10k	1/16W	5%	RMC1/16 103JATP	J24185103		1-	A	C3
R 3256	CHIP RES.	10k	1/16W	5%	RMC1/16 103JATP	J24185103		1-	A	E2
R 3257	CHIP RES.	10k	1/16W	5%	RMC1/16 103JATP	J24185103		1-	B	h2
R 3258	CHIP RES.	10k	1/16W	5%	RMC1/16 103JATP	J24185103		1-	B	g2
R 3259	CHIP RES.	0	1/16W	5%	RMC1/16 000JATP	J24185000		1-3	A	F3
R 3260	CHIP RES.	0	1/16W	5%	RMC1/16 000JATP	J24185000		1-	A	E3
R 3262	CHIP RES.	0	1/16W	5%	RMC1/16 000JATP	J24185000		1-	A	D1
R 3263	CHIP RES.	0	1/16W	5%	RMC1/16 000JATP	J24185000		1-	A	F3
R 3264	CHIP RES.	0	1/16W	5%	RMC1/16 000JATP	J24185000		1-	A	G3
R 3265	CHIP RES.	0	1/16W	5%	RMC1/16 000JATP	J24185000		1-	A	G3
R 3266	CHIP RES.	0	1/16W	5%	RMC1/16 000JATP	J24185000		1-	A	E3
R 3267	CHIP RES.	10k	1/16W	5%	RMC1/16 103JATP	J24185103		1-	A	E3
R 3269	CHIP RES.	39k	1/16W	5%	RMC1/16 393JATP	J24185393		1-	A	E3
R 3270	CHIP RES.	10k	1/16W	5%	RMC1/16 103JATP	J24185103		1-	A	E1
R 3271	CHIP RES.	10k	1/16W	5%	RMC1/16 103JATP	J24185103		1-	A	E2
R 3273	CHIP RES.	0	1/16W	5%	RMC1/16 000JATP	J24185000		1-	A	E2
R 3274	CHIP RES.	0	1/16W	5%	RMC1/16 000JATP	J24185000		1-	B	f1
R 3275	CHIP RES.	5.6k	1/16W	5%	RMC1/16 562JATP	J24185562		1-	A	E2
R 3276	CHIP RES.	68k	1/16W	5%	RMC1/16 683JATP	J24185683		1-	B	h2
R 3277	CARBON FILM RES.	10k	1/6W	5%	RD16PJ103 10K	J01225103		1-2	B	g3
R 3277	CHIP RES.	10k	1/16W	5%	RMC1/16 103JATP	J24185103		3-	B	g3
R 3278	CHIP RES.	10k	1/16W	5%	RMC1/16 103JATP	J24185103		1-	A	D1
R 3279	CHIP RES.	270k	1/16W	5%	RMC1/16 274JATP	J24185274		1-	B	h2
R 3282	CARBON FILM RES.	1k	1/6W	5%	RD16PJ102 1K	J01225102		1-2	B	b2
R 3282	CHIP RES.	1k	1/16W	5%	RMC1/16 102JATP	J24185102		3-	B	b2
R 3283	CHIP RES.	47k	1/16W	5%	RMC1/16 473JATP	J24185473		3-	A	B2
R 3284	CHIP RES.	47k	1/16W	5%	RMC1/16 473JATP	J24185473		3-	B	g2
R 3285	CHIP RES.	47k	1/16W	5%	RMC1/16 473JATP	J24185473		3-	A	B2
R 3286	CHIP RES.	47k	1/16W	5%	RMC1/16 473JATP	J24185473		3-	A	B1
R 3287	CHIP RES.	0	1/16W	5%	RMC1/16 000JATP	J24185000		3-	A	B1
R 3288	CARBON FILM RES.	2.2k	1/6W	5%	RD16PJ222 2.2K	J01225222		4-		
R 3289	CARBON FILM RES.	1k	1/6W	5%	RD16TPJ102 1K	J07225102		30-		
X 3001	XTAL TRS-4.0	4MHz			4.000MHZ	H0103283		1-107	B	f1
X 3001	XTAL TRS-3.5A	4MHz			4.000MHZ	H0103434		108-	B	f1
X 3002	XTAL TRS-4.0	12.288MHz			12.288MHZ	H0103291		1-109	B	d2
X 3002	XTAL TRS-3.5A	12.288MHz			12.288MHZ	H0103433		110-127	B	d2
X 3002	XTAL AT-41CD2	12.288MHz			12.288MHZ	H0103445		128-	B	d2

CNTL Unit

Note

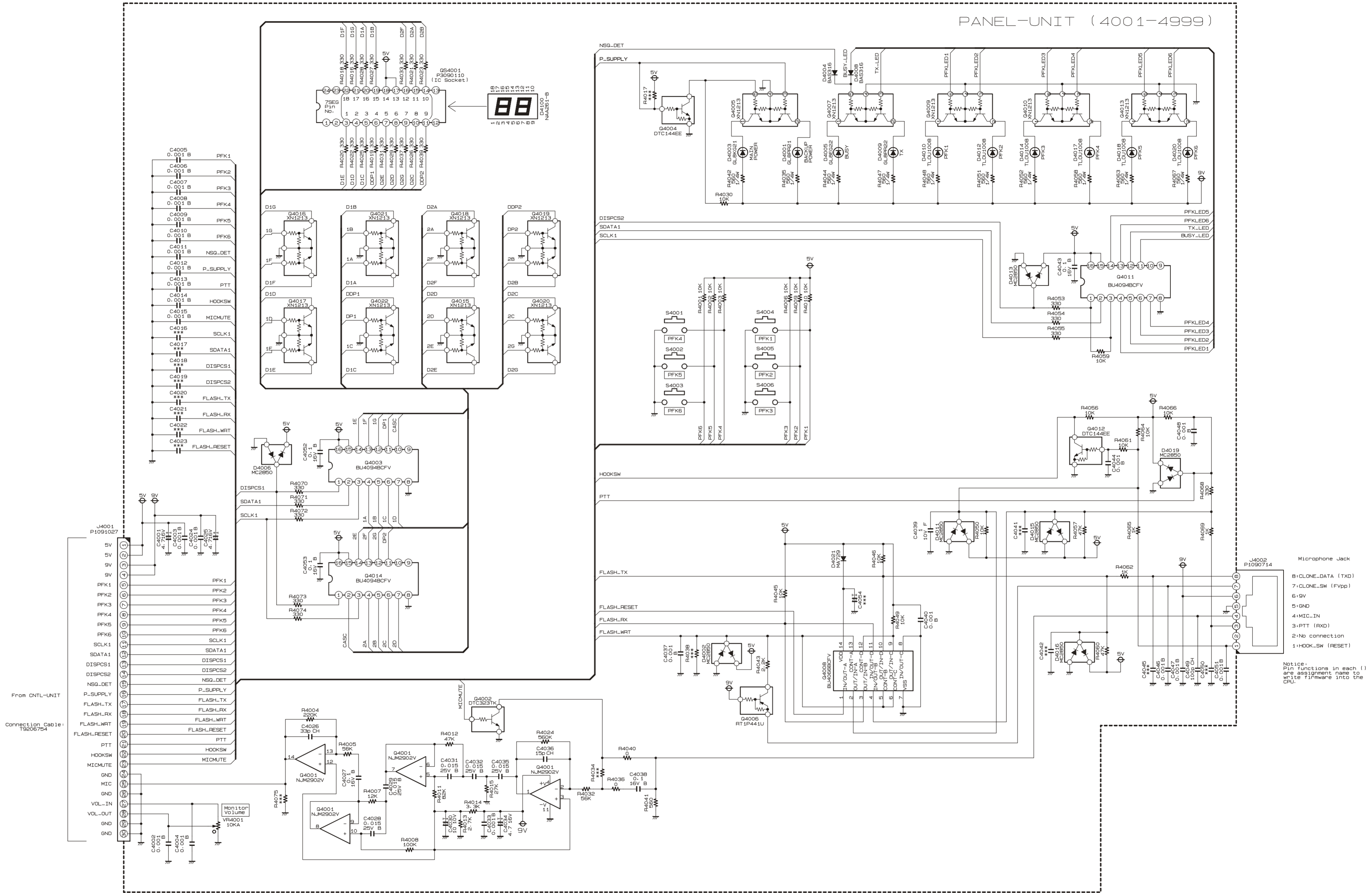

PANEL Unit

Note

PANEL Unit

Parts Layout (Side A)

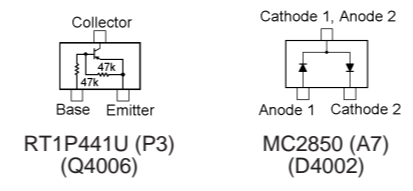
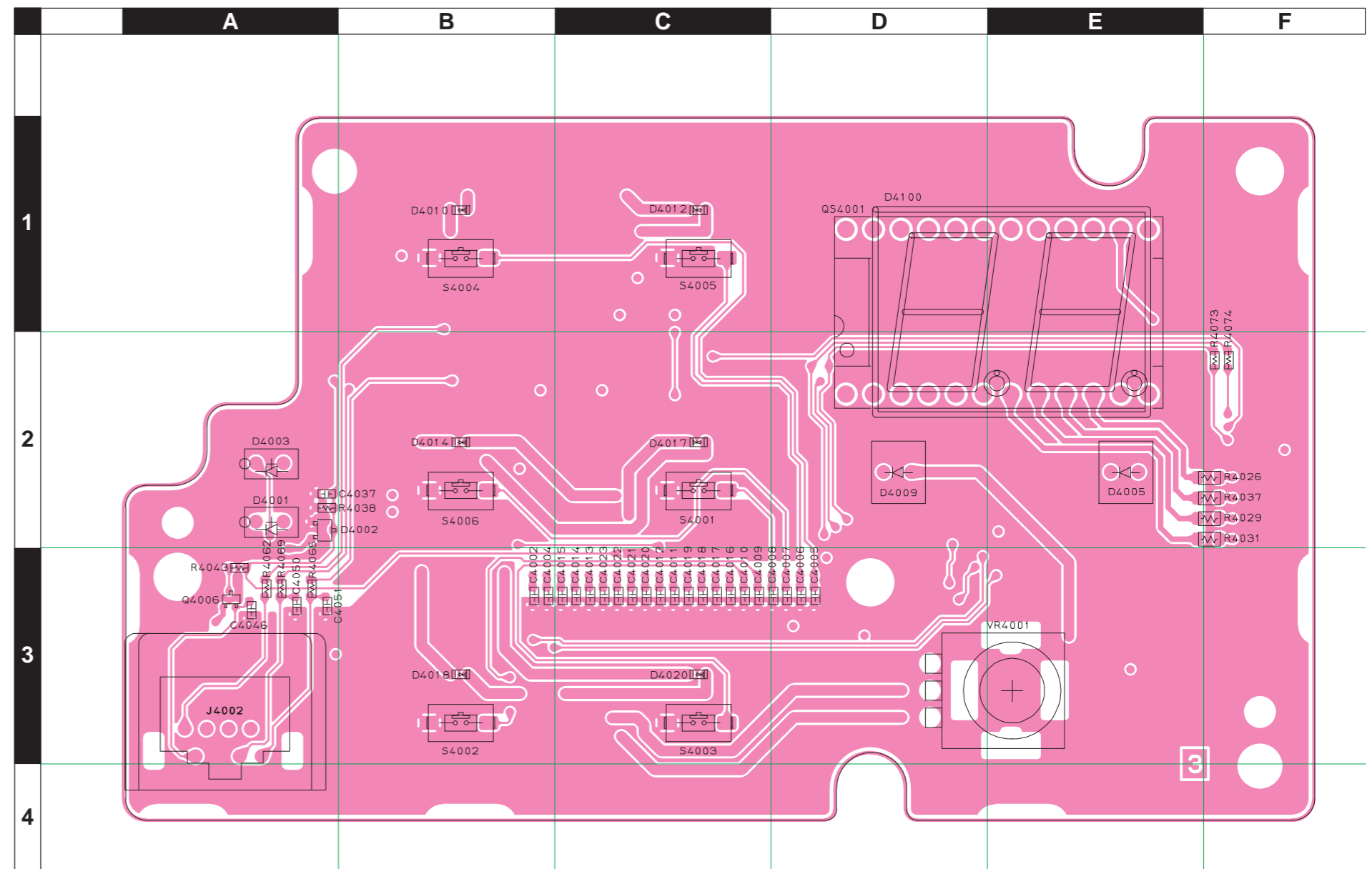

PANEL Unit

Parts Layout (Side B)

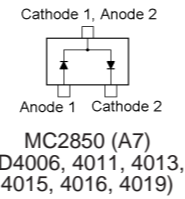
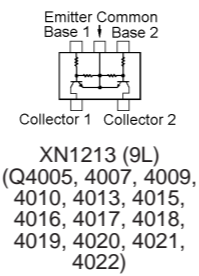
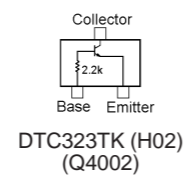
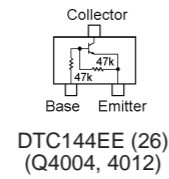
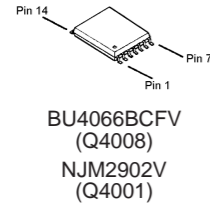
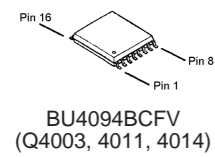
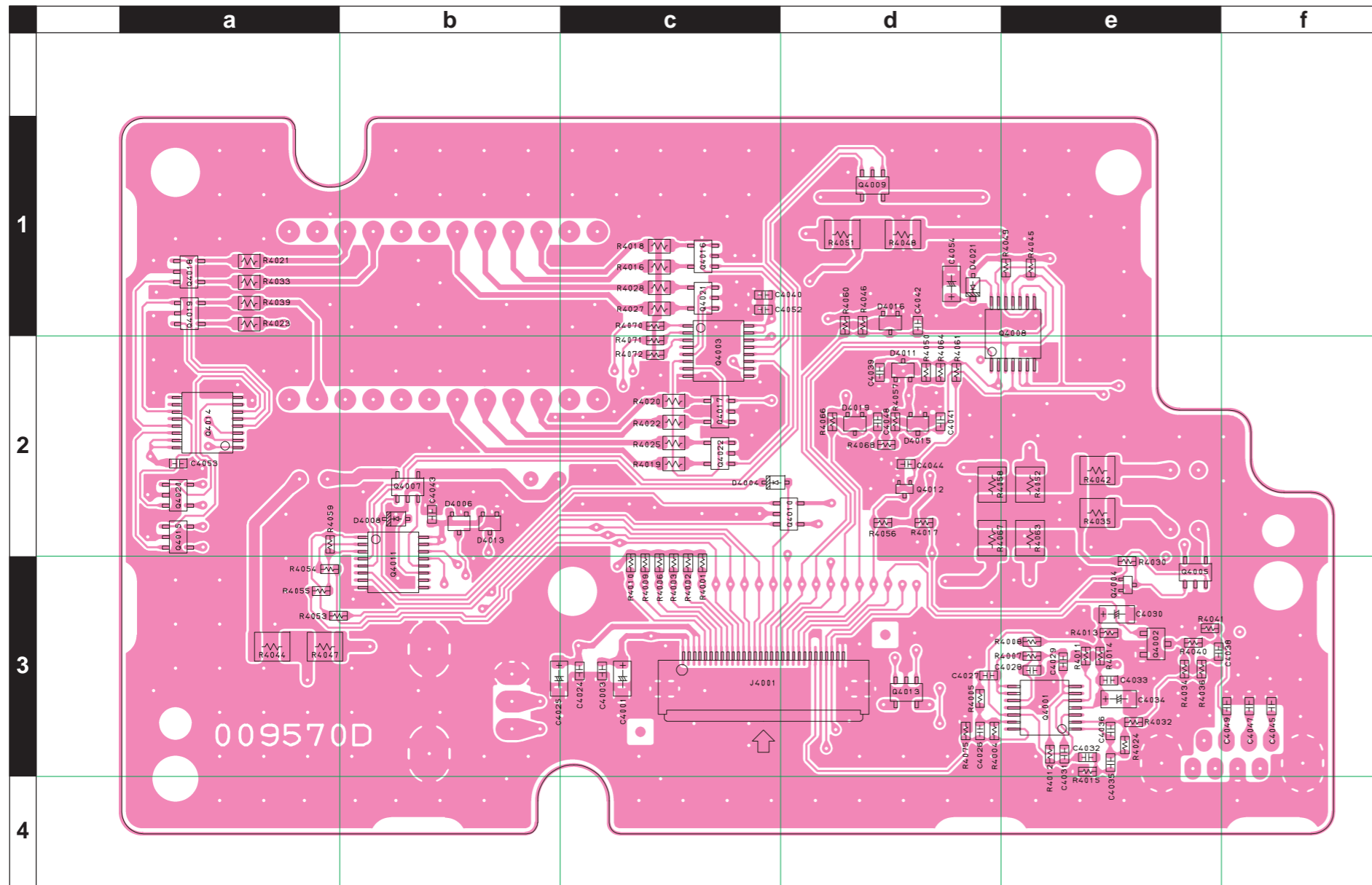

PANEL Unit

Parts List

REF	DESCRIPTION	VALUE	V/W	TOL.	MFR'S DESIG	VXSTD P/N	VERS.	LOT	SIDE	LAY ADR
PCB with Components						CB2328002	DST: USA			
						CB2328003	DST: EXP			
						CB2328004	DST: AUS			
C 4001	CHIP TA.CAP.	4.7uF	16V		TEESVA1C475M8R	K78120031		1-	B	c3
C 4002	CHIP CAP.	0.001uF	50V	B	GRM188B11H102KA01D	K22174821		1-	A	B3
C 4003	CHIP CAP.	0.001uF	50V	B	GRM188B11H102KA01D	K22174821		1-	B	c3
C 4004	CHIP CAP.	0.001uF	50V	B	GRM188B11H102KA01D	K22174821		1-	A	B3
C 4005	CHIP CAP.	0.001uF	50V	B	GRM188B11H102KA01D	K22174821		1-	A	D3
C 4006	CHIP CAP.	0.001uF	50V	B	GRM188B11H102KA01D	K22174821		1-	A	D3
C 4007	CHIP CAP.	0.001uF	50V	B	GRM188B11H102KA01D	K22174821		1-	A	D3
C 4008	CHIP CAP.	0.001uF	50V	B	GRM188B11H102KA01D	K22174821		1-	A	C3
C 4009	CHIP CAP.	0.001uF	50V	B	GRM188B11H102KA01D	K22174821		1-	A	C3
C 4010	CHIP CAP.	0.001uF	50V	B	GRM188B11H102KA01D	K22174821		1-	A	C3
C 4011	CHIP CAP.	0.001uF	50V	B	GRM188B11H102KA01D	K22174821		1-	A	C3
C 4012	CHIP CAP.	0.001uF	50V	B	GRM188B11H102KA01D	K22174821		1-	A	C3
C 4013	CHIP CAP.	0.001uF	50V	B	GRM188B11H102KA01D	K22174821		1-	A	C3
C 4014	CHIP CAP.	0.001uF	50V	B	GRM188B11H102KA01D	K22174821		1-	A	C3
C 4015	CHIP CAP.	0.001uF	50V	B	GRM188B11H102KA01D	K22174821		1-	A	C3
C 4024	CHIP CAP.	0.001uF	50V	B	GRM188B11H102KA01D	K22174821		1-	B	c3
C 4025	CHIP TA.CAP.	4.7uF	16V		TEESVA1C475M8R	K78120031		1-	B	b3
C 4026	CHIP CAP.	33pF	50V	CH	GRM1882C1H330JA01D	K22174223		1-	B	d3
C 4027	CHIP CAP.	0.1uF	16V	B	GRM188B11C104KA01D	K22124805		1-	B	d3
C 4028	CHIP CAP.	0.015uF	25V	B	GRM39B153K25PT	K22144805		1-45	B	e3
C 4028	CHIP CAP.	0.015uF	25V	B	GRM39B153K25PT	K22144805	AUS	46-47	B	e3
C 4028	CHIP CAP.	0.015uF	50V	B	GRM188B11H153KA01D	K22174838	AUS	48-	B	e3
C 4028	CHIP CAP.	0.015uF	25V	B	GRM39B153K25PT	K22144805	EXP	46-47	B	e3
C 4028	CHIP CAP.	0.015uF	50V	B	GRM188B11H153KA01D	K22174838	EXP	48-	B	e3
C 4028	CHIP CAP.	0.015uF	25V	B	GRM39B153K25PT	K22144805	USA	46-47	B	e3
C 4028	CHIP CAP.	0.015uF	50V	B	GRM188B11H153KA01D	K22174838	USA	48-	B	e3
C 4029	CHIP CAP.	0.015uF	25V	B	GRM39B153K25PT	K22144805		1-45	B	e3
C 4029	CHIP CAP.	0.015uF	25V	B	GRM39B153K25PT	K22144805	AUS	46-47	B	e3
C 4029	CHIP CAP.	0.015uF	50V	B	GRM188B11H153KA01D	K22174838	AUS	48-	B	e3
C 4029	CHIP CAP.	0.015uF	25V	B	GRM39B153K25PT	K22144805	EXP	46-47	B	e3
C 4029	CHIP CAP.	0.015uF	50V	B	GRM188B11H153KA01D	K22174838	EXP	48-	B	e3
C 4029	CHIP CAP.	0.015uF	25V	B	GRM39B153K25PT	K22144805	USA	46-47	B	e3
C 4029	CHIP CAP.	0.015uF	50V	B	GRM188B11H153KA01D	K22174838	USA	48-	B	e3
C 4030	CHIP TA.CAP.	10uF	10V		TEESVA1A106M8R	K78100028		1-	B	e3
C 4031	CHIP CAP.	0.015uF	25V	B	GRM39B153K25PT	K22144805		1-45	B	e3
C 4031	CHIP CAP.	0.015uF	25V	B	GRM39B153K25PT	K22144805	AUS	46-47	B	e3
C 4031	CHIP CAP.	0.015uF	50V	B	GRM188B11H153KA01D	K22174838	AUS	48-	B	e3
C 4031	CHIP CAP.	0.015uF	25V	B	GRM39B153K25PT	K22144805	EXP	46-47	B	e3
C 4031	CHIP CAP.	0.015uF	50V	B	GRM188B11H153KA01D	K22174838	EXP	48-	B	e3
C 4031	CHIP CAP.	0.015uF	25V	B	GRM39B153K25PT	K22144805	USA	46-47	B	e3
C 4031	CHIP CAP.	0.015uF	50V	B	GRM188B11H153KA01D	K22174838	USA	48-	B	e3
C 4032	CHIP CAP.	0.015uF	25V	B	GRM39B153K25PT	K22144805		1-45	B	e3
C 4032	CHIP CAP.	0.015uF	25V	B	GRM39B153K25PT	K22144805	AUS	46-47	B	e3
C 4032	CHIP CAP.	0.015uF	50V	B	GRM188B11H153KA01D	K22174838	AUS	48-	B	e3
C 4032	CHIP CAP.	0.015uF	25V	B	GRM39B153K25PT	K22144805	EXP	46-47	B	e3
C 4032	CHIP CAP.	0.015uF	50V	B	GRM188B11H153KA01D	K22174838	EXP	48-	B	e3
C 4032	CHIP CAP.	0.015uF	25V	B	GRM39B153K25PT	K22144805	USA	46-47	B	e3
C 4032	CHIP CAP.	0.015uF	50V	B	GRM188B11H153KA01D	K22174838	USA	48-	B	e3
C 4033	CHIP CAP.	0.001uF	50V	B	GRM188B11H102KA01D	K22174821		1-	B	e3
C 4034	CHIP TA.CAP.	4.7uF	16V		TEESVA1C475M8R	K78120031		1-	B	e3
C 4035	CHIP CAP.	0.015uF	25V	B	GRM39B153K25PT	K22144805		1-45	B	e3
C 4035	CHIP CAP.	0.015uF	25V	B	GRM39B153K25PT	K22144805	AUS	46-47	B	e3
C 4035	CHIP CAP.	0.015uF	50V	B	GRM188B11H153KA01D	K22174838	AUS	48-	B	e3
C 4035	CHIP CAP.	0.015uF	25V	B	GRM39B153K25PT	K22144805	EXP	46-47	B	e3
C 4035	CHIP CAP.	0.015uF	50V	B	GRM188B11H153KA01D	K22174838	EXP	48-	B	e3
C 4035	CHIP CAP.	0.015uF	25V	B	GRM39B153K25PT	K22144805	USA	46-47	B	e3
C 4035	CHIP CAP.	0.015uF	50V	B	GRM188B11H153KA01D	K22174838	USA	48-	B	e3
C 4036	CHIP CAP.	15pF	50V	CH	GRM1882C1H150JA01D	K22174215		1-	B	e3
C 4037	CHIP CAP.	0.001uF	50V	B	GRM188B11H102KA01D	K22174821		1-	A	A2
C 4038	CHIP CAP.	0.1uF	16V	B	GRM188B11C104KA01D	K22124805		1-	B	e3
C 4039	CHIP CAP.	1uF	10V	F	GRM188F11A105ZA01D	K22105001		1-	B	d2
C 4040	CHIP CAP.	0.001uF	50V	B	GRM188B11H102KA01D	K22174821		1-	B	c1
C 4043	CHIP CAP.	0.1uF	16V	B	GRM188B11C104KA01D	K22124805		1-	B	b2
C 4044	CHIP CAP.	0.001uF	50V	B	GRM188B11H102KA01D	K22174821		1-	B	d2
C 4046	CHIP CAP.	0.001uF	50V	B	GRM188B11H102KA01D	K22174821		1-	A	A3
C 4047	CHIP CAP.	0.001uF	50V	B	GRM188B11H102KA01D	K22174821		1-	B	f3
C 4048	CHIP CAP.	0.001uF	50V	B	GRM188B11H102KA01D	K22174821		1-	B	d2
C 4049	CHIP CAP.	100pF	50V	CH	GRM1882C1H101JA01D	K22174235		1-	B	f3
C 4051	CHIP CAP.	0.001uF	50V	B	GRM188B11H102KA01D	K22174821		1-	A	A3
C 4052	CHIP CAP.	0.1uF	16V	B	GRM188B11C104KA01D	K22124805		1-	B	c1

PANEL Unit

Parts List

REF	DESCRIPTION	VALUE	V/W	TOL.	MFR'S DESIG	VXSTD P/N	VERS.	LOT	SIDE	LAY ADR
C 4053	CHIP CAP.	0.1uF	16V	B	GRM188B11C104KA01D	K22124805		1-	B	a2
D 4001	LED				GL8PR21	G2090395		1-79	A	A2
D 4001	LED				SLB-25VR	G2090806		80-	A	A2
D 4002	DIODE				MC2850-T111-1	G2070704		1-	A	A2
D 4003	LED				GL8KG21	G2090625		1-87	A	A2
D 4003	LED				SLB-25MG	G2090807		88-	A	A2
D 4004	DIODE				BAS316	G2070716		1-	B	c2
D 4005	LED				GL8EG22	G2090561		1-68	A	E2
D 4005	LED				MPG5353K	G2090809		69-	A	E2
D 4006	DIODE				MC2850-T111-1	G2070704		1-	B	b2
D 4008	DIODE				BAS316	G2070716		1-	B	b2
D 4009	LED				GL8PR22	G2090431		1-68	A	D2
D 4009	LED				BR5353K	G2090808		69-	A	D2
D 4010	LED				TLOU1008(T04)	G2070796		1-127	A	B1
D 4010	LED				SML-512DWT86	G2071116		128-	A	B1
D 4011	DIODE				MC2850-T111-1	G2070704		1-	B	d2
D 4012	LED				TLOU1008(T04)	G2070796		1-127	A	C1
D 4012	LED				SML-512DWT86	G2071116		128-	A	C1
D 4013	DIODE				MC2850-T111-1	G2070704		1-	B	b2
D 4014	LED				TLOU1008(T04)	G2070796		1-127	A	B2
D 4014	LED				SML-512DWT86	G2071116		128-	A	B2
D 4015	DIODE				MC2850-T111-1	G2070704		1-	B	d2
D 4016	DIODE				MC2850-T111-1	G2070704		1-	B	d1
D 4017	LED				TLOU1008(T04)	G2070796		1-127	A	C2
D 4017	LED				SML-512DWT86	G2071116		128-	A	C2
D 4018	LED				TLOU1008(T04)	G2070796		1-127	A	B3
D 4018	LED				SML-512DWT86	G2071116		128-	A	B3
D 4019	DIODE				MC2850-T111-1	G2070704		1-	B	d2
D 4020	LED				TLOU1008(T04)	G2070796		1-127	A	C3
D 4020	LED				SML-512DWT86	G2071116		128-	A	C3
D 4021	DIODE				MA729-(TX)	G2070320		1-104	B	d1
D 4021	DIODE				DB2J31300L	G2071338		105-	B	d1
D 4100	LED				LB-602DA2	G2090779		1-		
J 4001	CONNECTOR				IL-FHR-F30S-HF-E3000	P1091027		1-3	B	c3
J 4001	CONNECTOR				9637S-30-Y905	P1091169		4-	B	c3
J 4002	CONNECTOR				R41-2509H	P1090714		1-	A	A4
JP4001	WIRE ASSY				BLK 70 (5)/(5)	T54007022		1-		
JP4002	WIRE ASSY				BLK 85 (5)/(5)	T54008522		1-		
Q 4001	IC				NJM2902V-TE1	G1091679		1-	B	e3
Q 4002	TRANSISTOR				DTC323TK T146	G3070042		1-	B	e3
Q 4003	IC				BU4094BCFV-E2	G1093527		1-	B	c2
Q 4004	TRANSISTOR				DTC144EE TL	G3070075		1-	B	e3
Q 4005	TRANSISTOR				XN1213-(TX)	G3070194		1-115	B	e3
Q 4005	TRANSISTOR				DMC261030L	G3070445		116-	B	e3
Q 4006	TRANSISTOR				RT1P441U-T11-1	G3070248		1-	A	A3
Q 4007	TRANSISTOR				XN1213-(TX)	G3070194		1-115	B	b2
Q 4007	TRANSISTOR				DMC261030L	G3070445		116-	B	b2
Q 4008	IC				BU4066BCFV-E2	G1093537		1-	B	e1
Q 4009	TRANSISTOR				XN1213-(TX)	G3070194		1-115	B	d1
Q 4009	TRANSISTOR				DMC261030L	G3070445		116-	B	d1
Q 4010	TRANSISTOR				XN1213-(TX)	G3070194		1-115	B	d2
Q 4010	TRANSISTOR				DMC261030L	G3070445		116-	B	d2
Q 4011	IC				BU4094BCFV-E2	G1093527		1-	B	b3
Q 4012	TRANSISTOR				DTC144EE TL	G3070075		1-	B	d2
Q 4013	TRANSISTOR				XN1213-(TX)	G3070194		1-	B	d3
Q 4014	IC				BU4094BCFV-E2	G1093527		1-	B	a2
Q 4015	TRANSISTOR				XN1213-(TX)	G3070194		1-115	B	a2
Q 4015	TRANSISTOR				DMC261030L	G3070445		116-	B	a2
Q 4016	TRANSISTOR				XN1213-(TX)	G3070194		1-115	B	c1
Q 4016	TRANSISTOR				DMC261030L	G3070445		116-	B	c1
Q 4017	TRANSISTOR				XN1213-(TX)	G3070194		1-115	B	c2
Q 4017	TRANSISTOR				DMC261030L	G3070445		116-	B	c2
Q 4018	TRANSISTOR				XN1213-(TX)	G3070194		1-115	B	a1
Q 4018	TRANSISTOR				DMC261030L	G3070445		116-	B	a1
Q 4019	TRANSISTOR				XN1213-(TX)	G3070194		1-115	B	a1
Q 4019	TRANSISTOR				DMC261030L	G3070445		116-	B	a1
Q 4020	TRANSISTOR				XN1213-(TX)	G3070194		1-115	B	a2
Q 4020	TRANSISTOR				DMC261030L	G3070445		116-	B	a2
Q 4021	TRANSISTOR				XN1213-(TX)	G3070194		1-115	B	c1
Q 4021	TRANSISTOR				DMC261030L	G3070445		116-	B	c1
Q 4022	TRANSISTOR				XN1213-(TX)	G3070194		1-115	B	c2
Q 4022	TRANSISTOR				DMC261030L	G3070445		116-	B	c2
QS4001	IC SOCKET				110-99-624	P3090110		1-16	A	E1

PANEL Unit

Parts List

REF	DESCRIPTION	VALUE	V/W	TOL.	MFR'S DESIG	VXSTD P/N	VERS.	LOT	SIDE	LAY ADR
QS4001	IC SOCKET				DIP624G11S1-F	P3090112		17-	A	E1
R 4001	CHIP RES.	10k	1/16W	5%	RMC1/16 103JATP	J24185103		1-	B	c3
R 4002	CHIP RES.	10k	1/16W	5%	RMC1/16 103JATP	J24185103		1-	B	c3
R 4003	CHIP RES.	10k	1/16W	5%	RMC1/16 103JATP	J24185103		1-	B	c3
R 4004	CHIP RES.	220k	1/16W	5%	RMC1/16 224JATP	J24185224		1-	B	d3
R 4005	CHIP RES.	56k	1/16W	5%	RMC1/16 563JATP	J24185563		1-	B	d3
R 4006	CHIP RES.	10k	1/16W	5%	RMC1/16 103JATP	J24185103		1-	B	c3
R 4007	CHIP RES.	12k	1/16W	5%	RMC1/16 123JATP	J24185123		1-	B	e3
R 4008	CHIP RES.	100k	1/16W	5%	RMC1/16 104JATP	J24185104		1-	B	e3
R 4009	CHIP RES.	10k	1/16W	5%	RMC1/16 103JATP	J24185103		1-	B	c3
R 4010	CHIP RES.	10k	1/16W	5%	RMC1/16 103JATP	J24185103		1-	B	c3
R 4011	CHIP RES.	82k	1/16W	5%	RMC1/16 823JATP	J24185823		1-	B	e3
R 4012	CHIP RES.	47k	1/16W	5%	RMC1/16 473JATP	J24185473		1-	B	e3
R 4013	CHIP RES.	2.7k	1/16W	5%	RMC1/16 272JATP	J24185272		1-	B	e3
R 4014	CHIP RES.	3.3k	1/16W	5%	RMC1/16 332JATP	J24185332		1-	B	e3
R 4015	CHIP RES.	27k	1/16W	5%	RMC1/16 273JATP	J24185273		1-45	B	e3
R 4015	CHIP RES.	27k	1/16W	5%	RMC1/16 273JATP	J24185273	AUS	46-	B	e3
R 4015	CHIP RES.	27k	1/16W	5%	RMC1/16 273JATP	J24185273	EXP	46-	B	e3
R 4015	CHIP RES.	27k	1/16W	5%	RMC1/16 273JATP	J24185273	USA	46-	B	e3
R 4016	CHIP RES.	330	1/10W	5%	RMC1/10T 331J	J24205331		1-	B	c1
R 4018	CHIP RES.	330	1/10W	5%	RMC1/10T 331J	J24205331		1-	B	c1
R 4019	CHIP RES.	330	1/10W	5%	RMC1/10T 331J	J24205331		1-	B	c2
R 4020	CHIP RES.	330	1/10W	5%	RMC1/10T 331J	J24205331		1-	B	c2
R 4021	CHIP RES.	330	1/10W	5%	RMC1/10T 331J	J24205331		1-	B	a1
R 4022	CHIP RES.	330	1/10W	5%	RMC1/10T 331J	J24205331		1-	B	c2
R 4023	CHIP RES.	330	1/10W	5%	RMC1/10T 331J	J24205331		1-	B	a1
R 4024	CHIP RES.	560k	1/16W	5%	RMC1/16 564JATP	J24185564		1-	B	e3
R 4025	CHIP RES.	330	1/10W	5%	RMC1/10T 331J	J24205331		1-	B	c2
R 4026	CHIP RES.	330	1/10W	5%	RMC1/10T 331J	J24205331		1-	A	F2
R 4027	CHIP RES.	330	1/10W	5%	RMC1/10T 331J	J24205331		1-	B	c1
R 4028	CHIP RES.	330	1/10W	5%	RMC1/10T 331J	J24205331		1-	B	c1
R 4029	CHIP RES.	330	1/10W	5%	RMC1/10T 331J	J24205331		1-	A	F2
R 4030	CHIP RES.	10k	1/16W	5%	RMC1/16 103JATP	J24185103		1-	B	e3
R 4031	CHIP RES.	330	1/10W	5%	RMC1/10T 331J	J24205331		1-	A	F2
R 4032	CHIP RES.	56k	1/16W	5%	RMC1/16 563JATP	J24185563		1-	B	e3
R 4033	CHIP RES.	330	1/10W	5%	RMC1/10T 331J	J24205331		1-	B	a1
R 4035	CHIP RES.	560	1/4W	5%	RMC1/4 561JATP	J24245561		1-79	B	e2
R 4035	CHIP RES.	680	1/4W	5%	RMC1/4 681JATP	J24245681		80-	B	e2
R 4036	CHIP RES.	0	1/16W	5%	RMC1/16 000JATP	J24185000		1-	B	e3
R 4037	CHIP RES.	330	1/10W	5%	RMC1/10T 331J	J24205331		1-	A	F2
R 4039	CHIP RES.	330	1/10W	5%	RMC1/10T 331J	J24205331		1-	B	a1
R 4040	CHIP RES.	0	1/16W	5%	RMC1/16 000JATP	J24185000		1-	B	e3
R 4041	CHIP RES.	560	1/16W	5%	RMC1/16 561JATP	J24185561		1-	B	e3
R 4042	CHIP RES.	560	1/4W	5%	RMC1/4 561JATP	J24245561		1-	B	e2
R 4043	CHIP RES.	2.2k	1/16W	5%	RMC1/16 222JATP	J24185222		1-	A	A3
R 4044	CHIP RES.	560	1/4W	5%	RMC1/4 561JATP	J24245561		1-	B	a3
R 4045	CHIP RES.	10k	1/16W	5%	RMC1/16 103JATP	J24185103		1-	B	e1
R 4046	CHIP RES.	10k	1/16W	5%	RMC1/16 103JATP	J24185103		1-	B	d1
R 4047	CHIP RES.	560	1/4W	5%	RMC1/4 561JATP	J24245561		1-68	B	a3
R 4047	CHIP RES.	680	1/4W	5%	RMC1/4 681JATP	J24245681		69-	B	a3
R 4048	CHIP RES.	560	1/4W	5%	RMC1/4 561JATP	J24245561		1-	B	d1
R 4049	CHIP RES.	10k	1/16W	5%	RMC1/16 103JATP	J24185103		1-	B	e1
R 4050	CHIP RES.	10k	1/16W	5%	RMC1/16 103JATP	J24185103		1-	B	d2
R 4051	CHIP RES.	560	1/4W	5%	RMC1/4 561JATP	J24245561		1-	B	d1
R 4052	CHIP RES.	560	1/4W	5%	RMC1/4 561JATP	J24245561		1-	B	e2
R 4053	CHIP RES.	330	1/16W	5%	RMC1/16 331JATP	J24185331		1-	B	a3
R 4054	CHIP RES.	330	1/16W	5%	RMC1/16 331JATP	J24185331		1-	B	a3
R 4055	CHIP RES.	330	1/16W	5%	RMC1/16 331JATP	J24185331		1-	B	a3
R 4056	CHIP RES.	10k	1/16W	5%	RMC1/16 103JATP	J24185103		1-	B	d2
R 4057	CHIP RES.	47k	1/16W	5%	RMC1/16 473JATP	J24185473		1-	B	d2
R 4058	CHIP RES.	560	1/4W	5%	RMC1/4 561JATP	J24245561		1-	B	d2
R 4059	CHIP RES.	10k	1/16W	5%	RMC1/16 103JATP	J24185103		1-	B	a2
R 4060	CHIP RES.	47k	1/16W	5%	RMC1/16 473JATP	J24185473		1-	B	d1
R 4061	CHIP RES.	10k	1/16W	5%	RMC1/16 103JATP	J24185103		1-	B	d2
R 4062	CHIP RES.	1k	1/16W	5%	RMC1/16 102JATP	J24185102		1-	A	A3
R 4063	CHIP RES.	560	1/4W	5%	RMC1/4 561JATP	J24245561		1-	B	e2
R 4064	CHIP RES.	10k	1/16W	5%	RMC1/16 103JATP	J24185103		1-	B	d2
R 4065	CHIP RES.	1k	1/16W	5%	RMC1/16 102JATP	J24185102		1-	A	A3
R 4066	CHIP RES.	10k	1/16W	5%	RMC1/16 103JATP	J24185103		1-	B	d2
R 4067	CHIP RES.	560	1/4W	5%	RMC1/4 561JATP	J24245561		1-	B	d2
R 4068	CHIP RES.	330	1/16W	5%	RMC1/16 331JATP	J24185331		1-	B	d2
R 4069	CHIP RES.	1k	1/16W	5%	RMC1/16 102JATP	J24185102		1-	A	A3
R 4070	CHIP RES.	330	1/16W	5%	RMC1/16 331JATP	J24185331		1-	B	c1

PANEL Unit

Parts List

REF	DESCRIPTION	VALUE	V/W	TOL.	MFR'S DESIG	VXSTD P/N	VERS.	LOT	SIDE	LAY ADR
R 4071	CHIP RES.	330	1/16W	5%	RMC1/16 331JATP	J24185331		1-	B	c2
R 4072	CHIP RES.	330	1/16W	5%	RMC1/16 331JATP	J24185331		1-	B	c2
R 4073	CHIP RES.	330	1/16W	5%	RMC1/16 331JATP	J24185331		1-	A	F2
R 4074	CHIP RES.	330	1/16W	5%	RMC1/16 331JATP	J24185331		1-	A	F2
S 4001	TACT SWITCH				SKQMAL	N5090105		1-62	A	C2
S 4001	TACT SWITCH				SKQMBBE010	N5090164		63-	A	C2
S 4002	TACT SWITCH				SKQMAL	N5090105		1-62	A	B3
S 4002	TACT SWITCH				SKQMBBE010	N5090164		63-	A	B3
S 4003	TACT SWITCH				SKQMAL	N5090105		1-62	A	C3
S 4003	TACT SWITCH				SKQMBBE010	N5090164		63-	A	C3
S 4004	TACT SWITCH				SKQMAL	N5090105		1-62	A	B1
S 4004	TACT SWITCH				SKQMBBE010	N5090164		63-	A	B1
S 4005	TACT SWITCH				SKQMAL	N5090105		1-62	A	C1
S 4005	TACT SWITCH				SKQMBBE010	N5090164		63-	A	C1
S 4006	TACT SWITCH				SKQMAL	N5090105		1-62	A	B2
S 4006	TACT SWITCH				SKQMBBE010	N5090164		63-	A	B2
VR4001	POT.				RK09L1141 F1B A14 10KA	J60800266		1-	A	E3
	LED SPACER				LH-3-6	S6000343		1-67		
	LED SPACER				LH-5-5	S6000238		69-		
	LED SPACER				LH-3-6	S6000343		1-67		
	LED SPACER				LH-5-5	S6000238		69-		
	LED SPACER				LH-3-8	S6000345		1-79		
	LED SPACER				LH-5-7	S6000240		80-		
	LED SPACER				LH-3-8	S6000345		1-87		
	LED SPACER				LH-5-7	S6000240		88-		

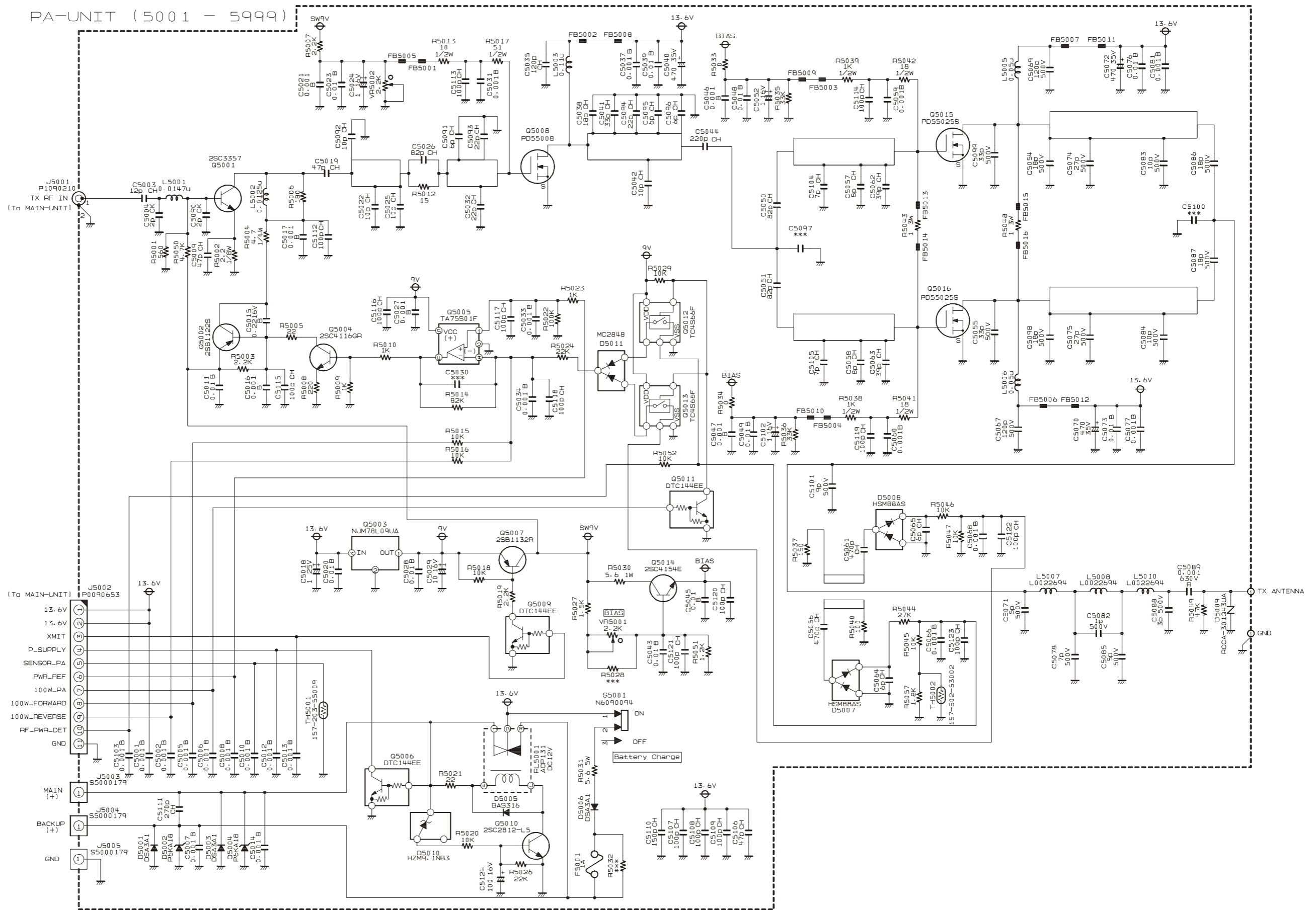

PA Unit (Lot. 1~2)

Note:

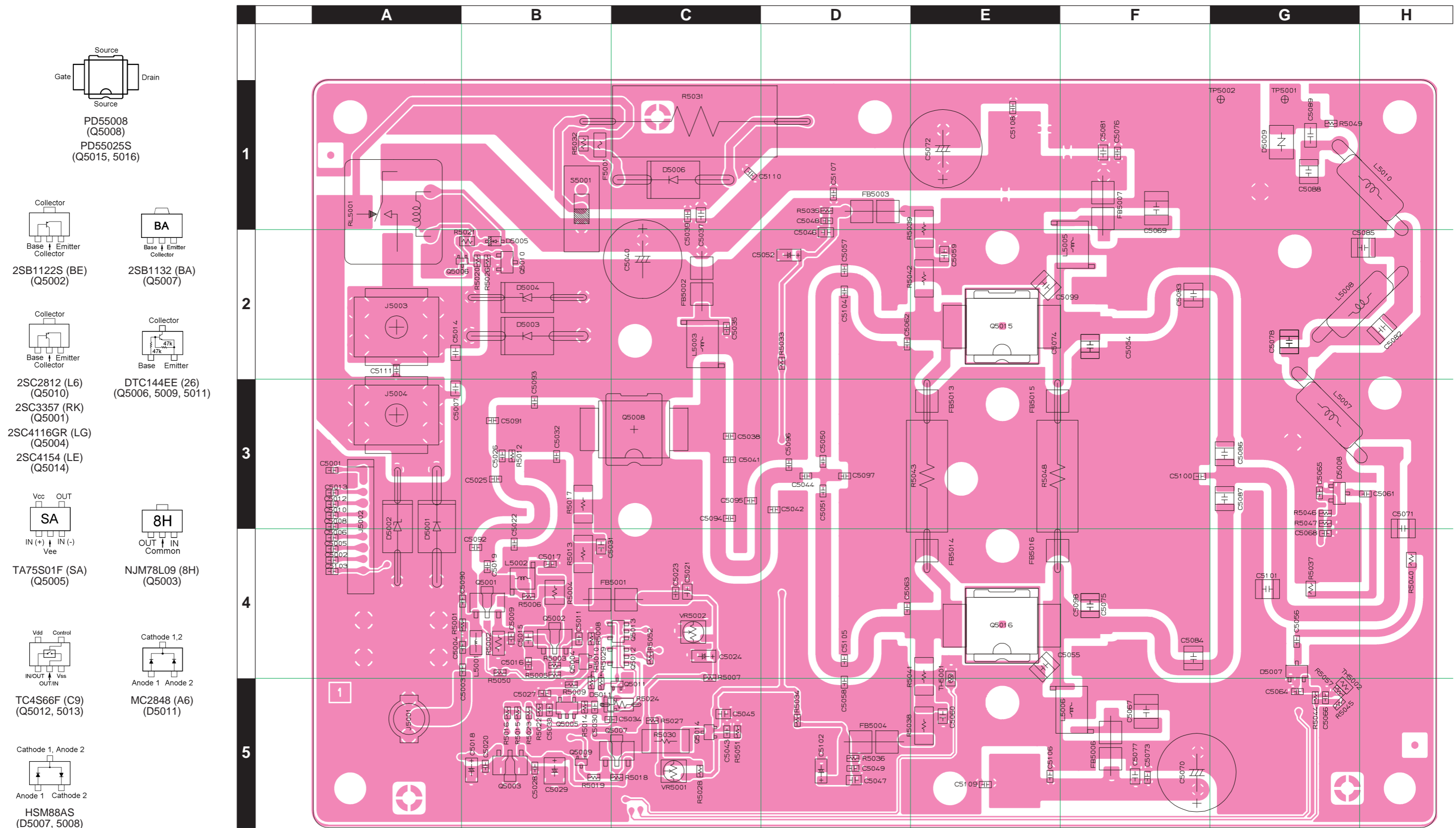

PA Unit (Lot. 1~2)

Parts Layout (Side B)

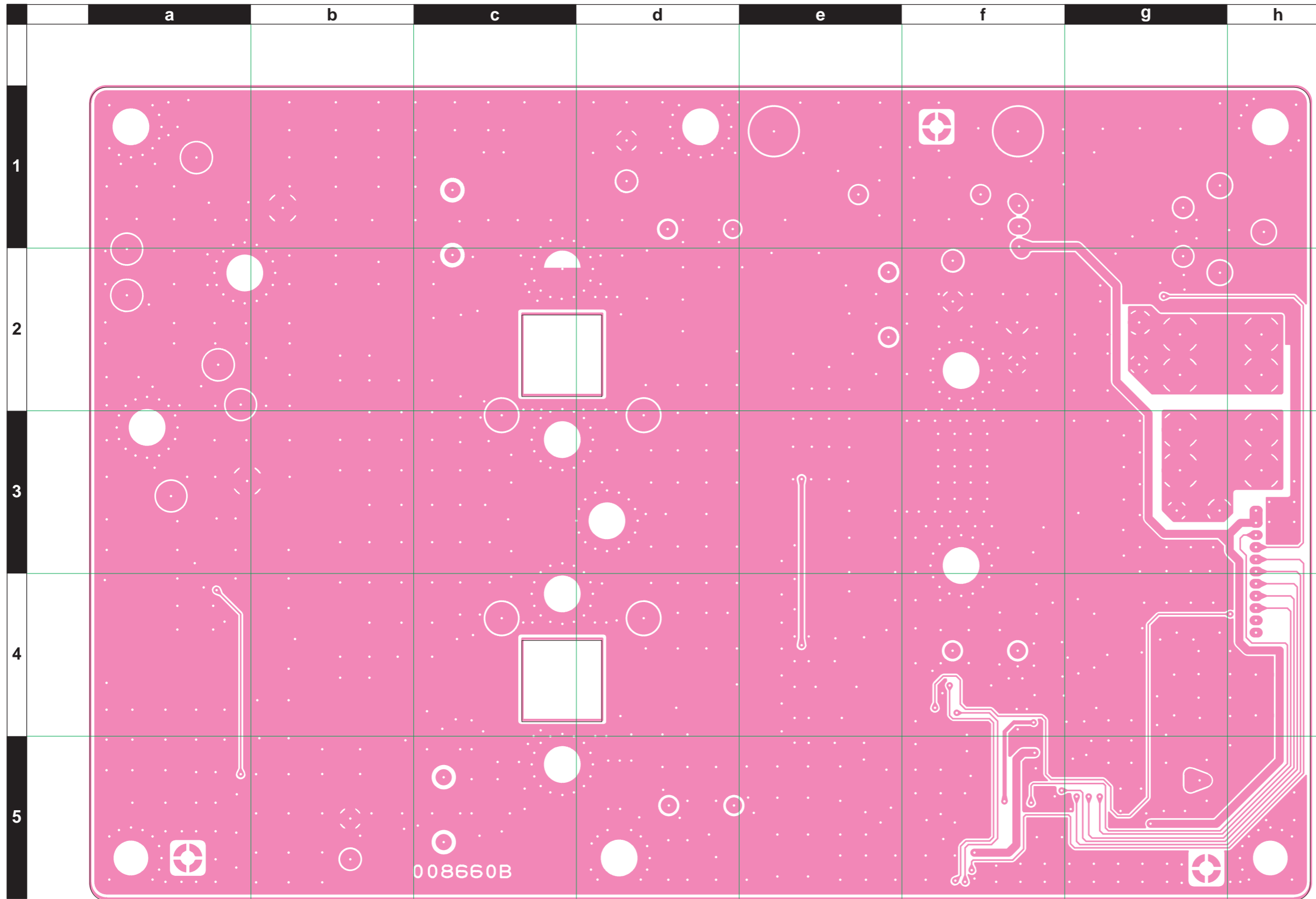

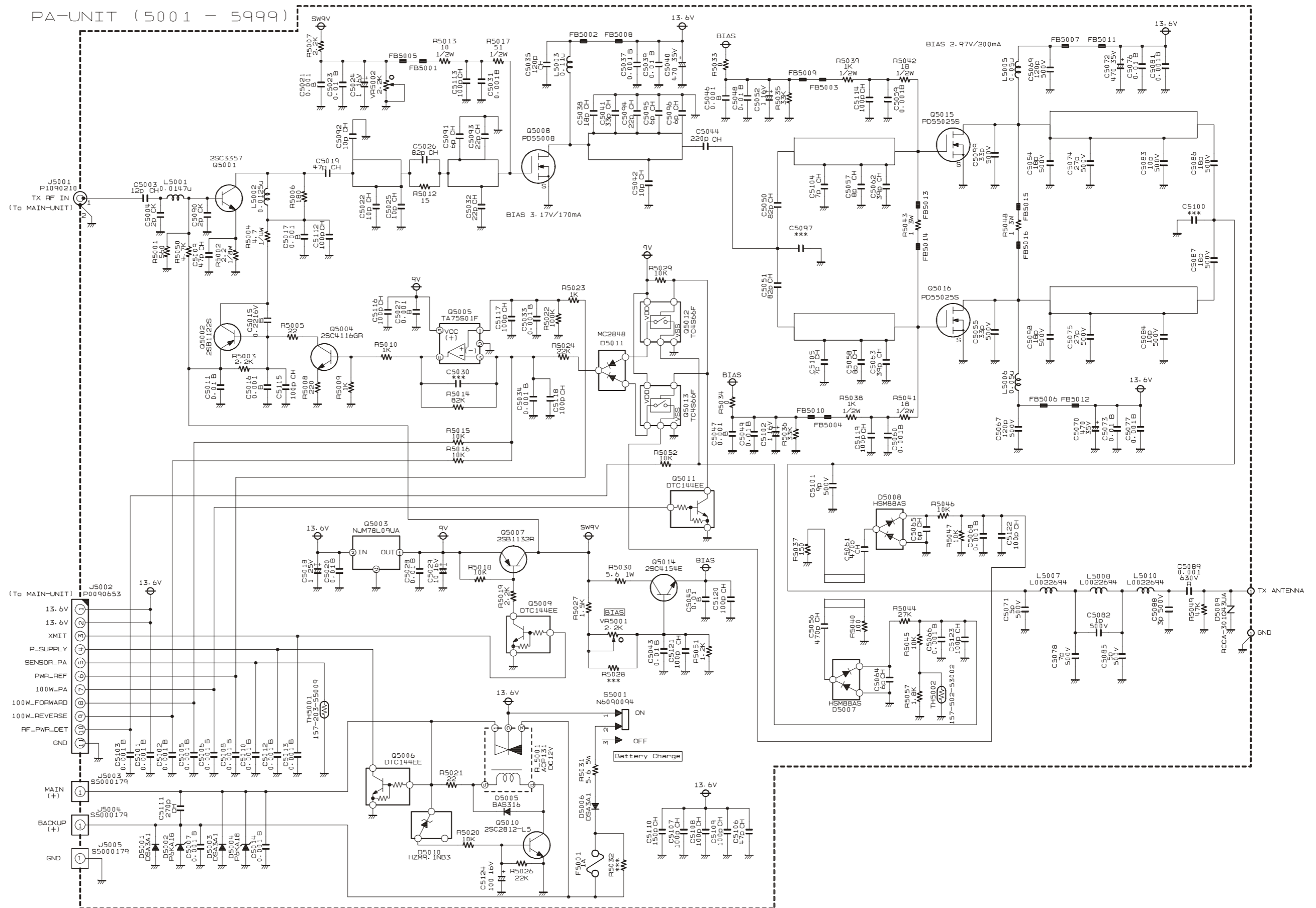

PA Unit (Lot. 3~20)

Note:

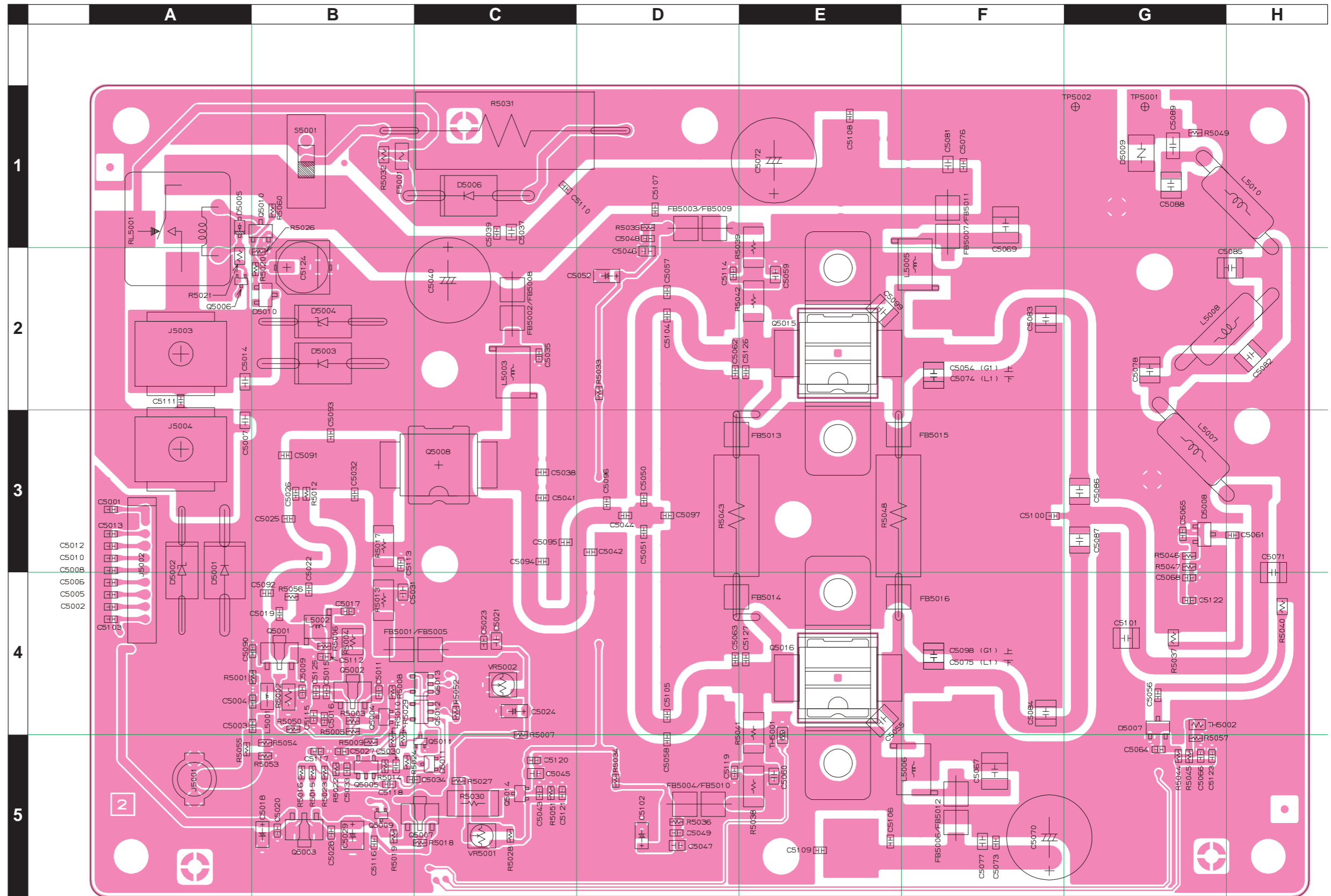
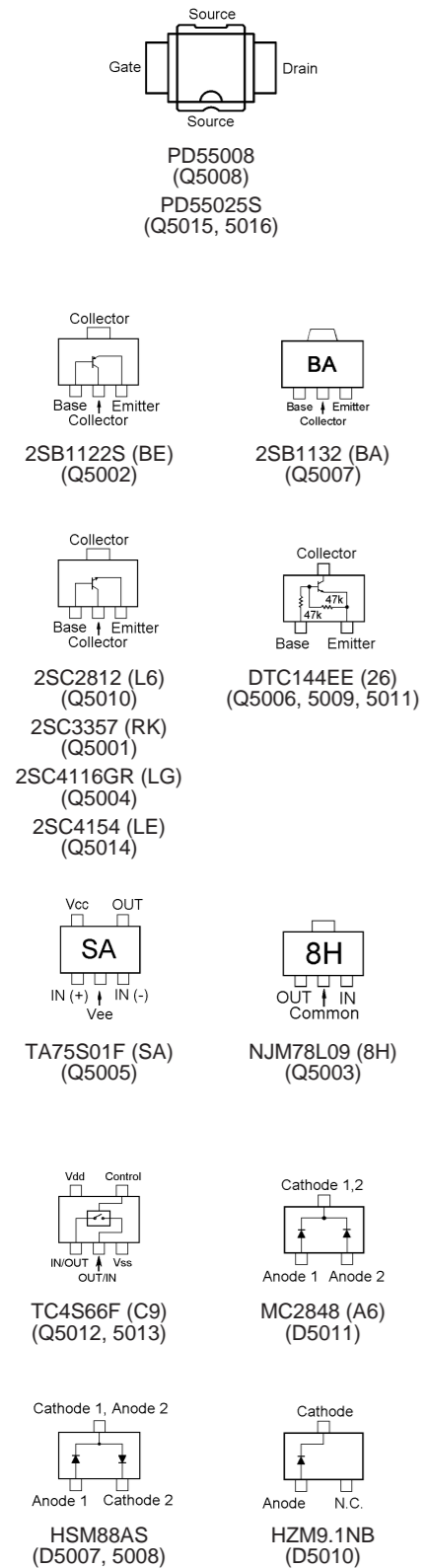

PA Unit (Lot. 3~20)

Parts Layout (Side B)

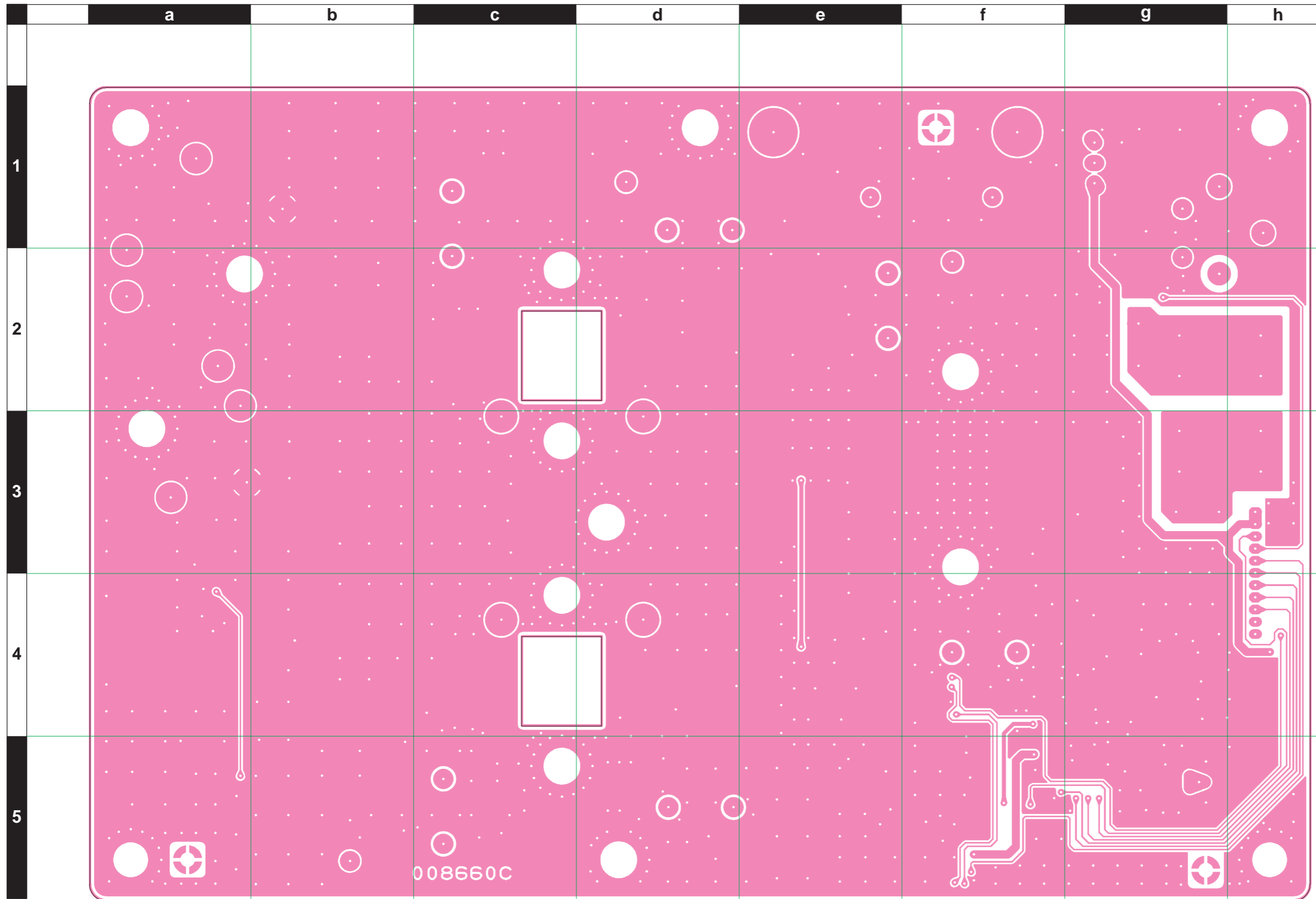

REF	DESCRIPTION	VALUE	V/W	TOL.	MFR'S DESIG	VXSTD P/N	VERS.	LOT	SIDE	LAY ADR
PCB with Components						CS1813001				
C 5001	CHIP CAP.	0.001uF	50V	B	GRM188B11H102KA01D	K22174821		1-	A	A3
C 5002	CHIP CAP.	0.001uF	50V	B	GRM188B11H102KA01D	K22174821		1-	A	A4
C 5003	CHIP CAP.	12pF	50V	CH	GRM1882C1H120JA01D	K22174213		1-	A	B4
C 5004	CHIP CAP.	2pF	50V	CK	GRM1884C1H2R0CZ01D	K22174203		1-	A	B5
C 5005	CHIP CAP.	0.001uF	50V	B	GRM188B11H102KA01D	K22174821		1-	A	B4
C 5006	CHIP CAP.	0.001uF	50V	B	GRM188B11H102KA01D	K22174821		1-	A	A4
C 5007	CHIP CAP.	0.001uF	50V	B	ECUV1H102KBN	K22179550		1-99	A	A3
C 5007	CHIP CAP.	0.001uF	50V	B	GRM216B11H102KA01D	K22170805		100-	A	A3
C 5008	CHIP CAP.	0.001uF	50V	B	GRM188B11H102KA01D	K22174821		1-	A	A3
C 5009	CHIP CAP.	470pF	50V	CH	GRM1882C1H471JA01D	K22174249		1-	A	A4
C 5010	CHIP CAP.	0.001uF	50V	B	GRM188B11H102KA01D	K22174821		1-	A	A3
C 5011	CHIP CAP.	0.01uF	50V	B	GRM188B11H103KA01D	K22174823		1-	A	B4
C 5012	CHIP CAP.	0.001uF	50V	B	GRM188B11H102KA01D	K22174821		1-	A	A3
C 5013	CHIP CAP.	0.001uF	50V	B	GRM188B11H102KA01D	K22174821		1-	A	A4
C 5014	CHIP CAP.	0.001uF	50V	B	ECUV1H102KBN	K22179550		1-99	A	A2
C 5014	CHIP CAP.	0.001uF	50V	B	GRM216B11H102KA01D	K22170805		100-	A	A2
C 5015	CHIP CAP.	0.22uF	16V	B	GRM219B11C224KC01D	K22120806		1-2	A	B4
C 5015	CHIP CAP.	0.22uF	10V	B	GRM188B11A224KA01D	K22104801		3-	A	B4
C 5016	CHIP CAP.	0.001uF	50V	B	GRM188B11H102KA01D	K22174821		1-	A	B4
C 5017	CHIP CAP.	0.001uF	50V	B	GRM188B11H102KA01D	K22174821		1-	A	B4
C 5018	CHIP TA.CAP.	1uF	25V		TEESVA1E105M8R	K78140013		1-	A	B5
C 5019	CHIP CAP.	47pF	50V	CH	GRM1882C1H470JA01D	K22174227		1-	A	B5
C 5020	CHIP CAP.	0.01uF	50V	B	GRM188B11H103KA01D	K22174823		1-	A	B3
C 5021	CHIP CAP.	0.001uF	50V	B	ECUV1H102KBN	K22179550		1-99	A	C4
C 5021	CHIP CAP.	0.001uF	50V	B	GRM216B11H102KA01D	K22170805		100-	A	C4
C 5022	CHIP CAP.	10pF	50V	CH	GRM1882C1H100JA01D	K22174211		1-	A	B4
C 5023	CHIP CAP.	0.01uF	50V	B	GRM188B11H103KA01D	K22174823		1-	A	C4
C 5025	CHIP CAP.	22pF	50V	CH	GRM1882C1H220JA01D	K22174219		1-	A	B3
C 5026	CHIP CAP.	82pF	50V	CH	GRM1882C1H820JA01D	K22174233		1-	A	B3
C 5027	CHIP CAP.	0.001uF	50V	B	GRM188B11H102KA01D	K22174821		1-	A	B5
C 5028	CHIP CAP.	0.01uF	50V	B	GRM188B11H103KA01D	K22174823		1-	A	B5
C 5029	CHIP TA.CAP.	10uF	16V		TEESVB21C106M8R	K78120025		1-	A	B5
C 5031	CHIP CAP.	0.001uF	50V	B	ECUV1H102KBN	K22179550		1-99	A	B4
C 5031	CHIP CAP.	0.001uF	50V	B	GRM216B11H102KA01D	K22170805		100-	A	B4
C 5032	CHIP CAP.	22pF	50V	CH	GRM1882C1H220JA01D	K22174219		1-	A	B2
C 5033	CHIP CAP.	0.001uF	50V	B	GRM188B11H102KA01D	K22174821		1-	A	C2
C 5034	CHIP CAP.	0.001uF	50V	B	GRM188B11H102KA01D	K22174821		1-	A	C2
C 5035	CHIP CAP.	120pF	50V	CH	GRM1882C1H121JA01D	K22174237		1-	A	C3
C 5037	CHIP CAP.	0.001uF	50V	B	ECUV1H102KBN	K22179550		1-99	A	C2
C 5037	CHIP CAP.	0.001uF	50V	B	GRM216B11H102KA01D	K22170805		100-	A	C2
C 5038	CHIP CAP.	22pF	50V	CH	GRM1882C1H220JA01D	K22174219		1-	A	C3
C 5039	CHIP CAP.	0.01uF	50V	B	GRM188B11H103KA01D	K22174823		1-	A	C1
C 5040	AL.ELECTRO.CAP.	470uF	35V		RE2-35V471MH5#	K40169026		1-	A	C2
C 5041	CHIP CAP.	33pF	50V	CH	GRM1882C1H330JA01D	K22174223		1-	A	E3
C 5042	CHIP CAP.	8pF	50V	CH	GRM1882C1H8R0DZ01D	K22174209		1-	A	D3
C 5043	CHIP CAP.	0.01uF	50V	B	GRM188B11H103KA01D	K22174823		1-	A	C5
C 5044	CHIP CAP.	220pF	50V	CH	GRM1882C1H221JA01D	K22174243		1-	A	D2
C 5045	CHIP CAP.	0.01uF	50V	B	ECUV1H103KBN	K22179562		1-	A	C5
C 5046	CHIP CAP.	0.001uF	50V	B	ECUV1H102KBN	K22179550		1-99	A	D2
C 5046	CHIP CAP.	0.001uF	50V	B	GRM216B11H102KA01D	K22170805		100-	A	D2
C 5047	CHIP CAP.	0.001uF	50V	B	ECUV1H102KBN	K22179550		1-99	A	D5
C 5047	CHIP CAP.	0.001uF	50V	B	GRM216B11H102KA01D	K22170805		100-	A	D5
C 5048	CHIP CAP.	0.01uF	50V	B	GRM188B11H103KA01D	K22174823		1-	A	D1
C 5049	CHIP CAP.	0.01uF	50V	B	GRM188B11H103KA01D	K22174823		1-	A	D5
C 5050	CHIP CAP.	82pF	50V	CH	GRM1882C1H820JA01D	K22174233		1-	A	E3
C 5051	CHIP CAP.	82pF	50V	CH	GRM1882C1H820JA01D	K22174233		1-	A	E3
C 5054	FILM CAP.	18pF	500V		UC232H0180J-T	K33279029		1-	A	F2
C 5055	FILM CAP.	33pF	500V		UC232H0330J-T	K33279024		1-	A	F2
C 5056	CHIP CAP.	470pF	50V	CH	GRM1882C1H471JA01D	K22174249		1-	A	F4
C 5057	CHIP CAP.	8pF	50V	CH	GRM1882C1H8R0DZ01D	K22174209		1-	A	E1
C 5058	CHIP CAP.	8pF	50V	CH	GRM1882C1H8R0DZ01D	K22174209		1-	A	F1
C 5059	CHIP CAP.	0.001uF	50V	B	ECUV1H102KBN	K22179550		1-99	A	F1
C 5059	CHIP CAP.	0.001uF	50V	B	GRM216B11H102KA01D	K22170805		100-	A	F1
C 5060	CHIP CAP.	0.001uF	50V	B	ECUV1H102KBN	K22179550		1-99	A	E1
C 5060	CHIP CAP.	0.001uF	50V	B	GRM216B11H102KA01D	K22170805		100-	A	E1
C 5061	CHIP CAP.	470pF	50V	CH	GRM1882C1H471JA01D	K22174249		1-	A	H3
C 5062	CHIP CAP.	39pF	50V	CH	GRM1882C1H390JA01D	K22174225		1-	A	D2
C 5063	CHIP CAP.	39pF	50V	CH	GRM1882C1H390JA01D	K22174225		1-	A	G1
C 5064	CHIP CAP.	6pF	50V	CH	GRM1882C1H6R0DZ01D	K22174207		1-	A	G3
C 5065	CHIP CAP.	6pF	50V	CH	GRM1882C1H6R0DZ01D	K22174207		1-	A	G5
C 5066	CHIP CAP.	0.001uF	50V	B	GRM188B11H102KA01D	K22174821		1-	A	G5
C 5067	FILM CAP.	120pF	500V		UC342H1200J-T	K33279026		1-	A	F5

PA Unit (Lot. 1~20)

Parts List

REF	DESCRIPTION	VALUE	V/W	TOL.	MFR'S DESIG	VXSTD P/N	VERS.	LOT	SIDE	LAY ADR
C 5068	CHIP CAP.	0.001uF	50V	B	GRM188B11H102KA01D	K22174821		1-	A	G4
C 5069	FILM CAP.	120pF	500V		UC342H1200J-T	K33279026		1-	A	F1
C 5070	AL.ELECTRO.CAP.	470uF	35V		RE2-35V471MH5#	K40169026		1-	A	F5
C 5071	FILM CAP.	5pF	500V		UC232H0050D-T	K33279010		1-	A	H4
C 5072	AL.ELECTRO.CAP.	470uF	35V		RE2-35V471MH5#	K40169026		1-	A	E1
C 5073	CHIP CAP.	0.01uF	50V	B	GRM188B11H103KA01D	K22174823		1-	A	F5
C 5074	FILM CAP.	27pF	500V		UC232H0270J-T	K33279023		1-	A	F2
C 5075	FILM CAP.	27pF	500V		UC232H0270J-T	K33279023		1-	A	F4
C 5076	CHIP CAP.	0.01uF	50V	B	GRM188B11H103KA01D	K22174823		1-	A	F1
C 5077	CHIP CAP.	0.001uF	50V	B	ECUV1H102KBN	K22179550		1-99	A	F5
C 5077	CHIP CAP.	0.001uF	50V	B	GRM216B11H102KA01D	K22170805		100-	A	F5
C 5078	FILM CAP.	7pF	500V		UC232H0070D-T	K33279046		1-	A	G2
C 5081	CHIP CAP.	0.001uF	50V	B	ECUV1H102KBN	K22179550		1-99	A	F1
C 5081	CHIP CAP.	0.001uF	50V	B	GRM216B11H102KA01D	K22170805		100-	A	F1
C 5082	FILM CAP.	1pF	500V		UC232H0010D-T	K33279036		1-3	A	H2
C 5082	FILM CAP.	2pF	500V		UC232H0020D-T	K33279043		4-	A	H2
C 5083	FILM CAP.	10pF	500V		UC232H0100D-T	K33279019		1-	A	F2
C 5084	FILM CAP.	10pF	500V		UC232H0100D-T	K33279019		1-	A	F4
C 5085	FILM CAP.	5pF	500V		UC232H0050D-T	K33279010		1-	A	H2
C 5086	FILM CAP.	18pF	500V		UC232H0180J-T	K33279029		1-	A	G3
C 5087	FILM CAP.	18pF	500V		UC232H0180J-T	K33279029		1-	A	G3
C 5088	FILM CAP.	3pF	500V		UC232H0030D-T	K33279027		1-	A	G1
C 5089	CHIP CAP.	0.001uF	630V	R	GRM31BR32J102KY01L	K22281801		1-	A	G1
C 5090	CHIP CAP.	2pF	50V	CK	GRM1884C1H2R0CZ01D	K22174203		1-	A	A4
C 5091	CHIP CAP.	6pF	50V	CH	GRM1882C1H6R0DZ01D	K22174207		1-	A	B3
C 5092	CHIP CAP.	10pF	50V	CH	GRM1882C1H100JA01D	K22174211		1-	A	B4
C 5093	CHIP CAP.	22pF	50V	CH	GRM1882C1H220JA01D	K22174219		1-	A	B3
C 5094	CHIP CAP.	22pF	50V	CH	GRM1882C1H220JA01D	K22174219		1-	A	C3
C 5095	CHIP CAP.	6pF	50V	CH	GRM1882C1H6R0DZ01D	K22174207		1-	A	C3
C 5096	CHIP CAP.	4pF	50V	CH	GRM1882C1H4R0CZ01D	K22174205		1-	A	D3
C 5098	FILM CAP.	18pF	500V		UC232H0180J-T	K33279029		1-	A	F4
C 5099	FILM CAP.	33pF	500V		UC232H0330J-T	K33279024		1-	A	E2
C 5100	FILM CAP.	3pF	500V		UC232H0030D-T	K33279027		4-	A	F3
C 5101	FILM CAP.	9pF	500V		UC232H0090D-T	K33279047		1-	A	G4
C 5103	CHIP CAP.	0.001uF	50V	B	GRM188B11H102KA01D	K22174821		1-	A	A4
C 5104	CHIP CAP.	7pF	50V	CH	GRM1882C1H7R0DZ01D	K22174208		1-3	A	D2
C 5104	CHIP CAP.	10pF	50V	CH	GRM1882C1H100JA01D	K22174211		4-	A	D2
C 5105	CHIP CAP.	7pF	50V	CH	GRM1882C1H7R0DZ01D	K22174208		1-3	A	D4
C 5105	CHIP CAP.	10pF	50V	CH	GRM1882C1H100JA01D	K22174211		4-	A	D4
C 5106	CHIP CAP.	47pF	50V	CH	GRM1882C1H470JA01D	K22174227		1-	A	E5
C 5107	CHIP CAP.	100pF	50V	CH	GRM1882C1H101JA01D	K22174235		1-	A	D1
C 5108	CHIP CAP.	100pF	50V	CH	GRM1882C1H101JA01D	K22174235		1-2	A	E1
C 5109	CHIP CAP.	100pF	50V	CH	GRM1882C1H101JA01D	K22174235		1-	A	E5
C 5110	CHIP CAP.	150pF	50V	CH	GRM1882C1H151JA01D	K22174239		1-	A	C1
C 5112	CHIP CAP.	100pF	50V	CH	GRM1882C1H101JA01D	K22174235		1-	A	B4
C 5113	CHIP CAP.	100pF	50V	CH	GRM1882C1H101JA01D	K22174235		1-	A	B3
C 5114	CHIP CAP.	100pF	50V	CH	GRM1882C1H101JA01D	K22174235		1-	A	D2
C 5115	CHIP CAP.	100pF	50V	CH	GRM1882C1H101JA01D	K22174235		1-	A	B4
C 5116	CHIP CAP.	100pF	50V	CH	GRM1882C1H101JA01D	K22174235		1-	A	B5
C 5117	CHIP CAP.	100pF	50V	CH	GRM1882C1H101JA01D	K22174235		1-	A	B5
C 5118	CHIP CAP.	100pF	50V	CH	GRM1882C1H101JA01D	K22174235		1-	A	B5
C 5119	CHIP CAP.	100pF	50V	CH	GRM1882C1H101JA01D	K22174235		1-	A	D5
C 5120	CHIP CAP.	100pF	50V	CH	GRM1882C1H101JA01D	K22174235		1-	A	C5
C 5121	CHIP CAP.	100pF	50V	CH	GRM1882C1H101JA01D	K22174235		1-	A	C5
C 5122	CHIP CAP.	100pF	50V	CH	GRM1882C1H101JA01D	K22174235		1-	A	G4
C 5123	CHIP CAP.	100pF	50V	CH	GRM1882C1H101JA01D	K22174235		1-	A	G5
C 5124	AL.ELECTRO.CAP.	100uF	16V		RE3-16V101ME3#	K40129063		1-2	A	B2
C 5124	AL.ELECTRO.CAP.	100uF	16V		EEE1CA101WP	K48120012		3-	A	B2
C 5125	CHIP CAP.	0.22uF	10V	B	GRM188B11A224KA01D	K22104801		1-	A	B4
C 5126	CHIP CAP.	10pF	50V	CH	GRM1882C1H100JA01D	K22174211		1-	A	E2
C 5127	CHIP CAP.	10pF	50V	CH	GRM1882C1H100JA01D	K22174211		1-	A	E4
C 5128	CHIP CAP.	8pF	50V	CH	GRM1882C1H8R0DZ01D	K22174209		4-		
D 5001	DIODE				DSA3A1	G2090445		1-	A	A3
D 5002	SURGE ABSORBER				P6KA18A-E3	Q9000721		1-114	A	A3
D 5002	SURGE ABSORBER				P6KA18A-HE3	Q9000721A		115-	A	A3
D 5003	DIODE				DSA3A1	G2090445		1-	A	B2
D 5004	SURGE ABSORBER				P6KA18A-E3	Q9000721		1-114	A	B2
D 5004	SURGE ABSORBER				P6KA18A-HE3	Q9000721A		115-	A	B2
D 5005	DIODE				BAS316	G2070716		1-	A	D3
D 5006	DIODE				DSA3A1	G2090445		1-	A	B1
D 5007	DIODE				HSM88AS TR-E	G2070170		1-	A	D2
D 5008	DIODE				HSM88AS TR-E	G2070170		1-	A	D3
D 5009	SURGE ABSORBER				RCCA-301Q43UA	Q9000756		1-4	A	G1

PA Unit (Lot. 1~20)

Parts List

REF	DESCRIPTION	VALUE	V/W	TOL.	MFR'S DESIG	VXSTD P/N	VERS.	LOT	SIDE	LAY ADR
D 5009	SURGE ABSORBER				RHCA-201Q43U	Q9000825		5-	A	G1
D 5010	DIODE				HZM9.1NB3 TR-E	G2070404		1-	A	F4
D 5011	DIODE				MC2848-T111-1	G2070694		1-	A	G3
F 5001	CHIP FUSE	1A			R429 001	Q0000089		1-	A	B1
FB5001	FERRITE BEADS				4A2 R13X3-1	L9190001		1-		
FB5002	FERRITE BEADS				4A2 R13X3-1	L9190001		1-		
FB5003	FERRITE BEADS				4A2 R13X3-1	L9190001		1-		
FB5004	FERRITE BEADS				4A2 R13X3-1	L9190001		1-		
FB5005	FERRITE BEADS				4A2 R13X3-1	L9190001		1-		
FB5006	FERRITE BEADS				4A2 R13X3-1	L9190001		1-		
FB5007	FERRITE BEADS				4A2 R13X3-1	L9190001		1-		
FB5008	FERRITE BEADS				4A2 R13X3-1	L9190001		1-		
FB5009	FERRITE BEADS				4A2 R13X3-1	L9190001		1-		
FB5010	FERRITE BEADS				4A2 R13X3-1	L9190001		1-		
FB5011	FERRITE BEADS				4A2 R13X3-1	L9190001		1-		
FB5012	FERRITE BEADS				4A2 R13X3-1	L9190001		1-		
FB5013	FERRITE BEADS				4A2 R13X3-1	L9190001		1-		
FB5014	FERRITE BEADS				4A2 R13X3-1	L9190001		1-		
FB5015	FERRITE BEADS				4A2 R13X3-1	L9190001		1-		
FB5016	FERRITE BEADS				4A2 R13X3-1	L9190001		1-		
J 5001	CONNECTOR				TMP-J01X-V6	P1090210		1-	A	A5
J 5002	CONNECTOR				IL-Y-11P-S15T2-E	P0090653		1-	A	B4
J 5003	TERMINAL				Y106	S5000179		1-	A	G3
J 5004	TERMINAL				Y106	S5000179		1-	A	G4
JP5001	WIRE ASSY				GRN 20 2/2	T50502000		1-2		
L 5001	CHIP COIL	0.0147uH			LQW31HN15NJ03L	L1690251		1-	A	A4
L 5002	M.RFC	0.0125uH			C3328A-12NG-RA-T25H	L1691077		1-	A	B4
L 5003	M.RFC	0.11uH		2%	C6342A-R11G-RA	L1691087		1-	A	C2
L 5005	M.RFC	0.05uH		2%	C6342A-50NG-RA	L1691084		1-	A	F2
L 5006	M.RFC	0.05uH		2%	C6342A-50NG-RA	L1691084		1-	A	F5
L 5007	COIL C1				1.0T6.0D1.6PEW R	L0022694		1-	A	G2
L 5008	COIL C1				1.0T6.0D1.6PEW R	L0022694		1-	A	H2
L 5010	COIL C1				1.0T6.0D1.6PEW R	L0022694		1-	A	G1
P 5001	WIRE ASSY				RED 125 <T>/<T>	T9318109		1-		
P 5002	TERMINAL				B5 AG M3	Q6000115		1-22		
P 5002	TERMINAL				B5 AG M3	Q6000115		23-		
Q 5001	TRANSISTOR				2SC3357-T2	G3333577		1-	A	B4
Q 5002	TRANSISTOR				2SB1122S-TD	G3211228S		1-	A	B4
Q 5003	IC				NJM78L09UA-TE2	G1091305		1-	A	A3
Q 5004	TRANSISTOR				2SC4116GR(TE85R.F)	G3341167G		1-	A	B4
Q 5005	IC				TA75S01F(TE85R.F)	G1091593		1-	A	C5
Q 5006	TRANSISTOR				DTC144EE TL	G3070075		1-	A	A2
Q 5007	TRANSISTOR				2SB1132 T100 R	G3211327R		1-	A	C5
Q 5008	FET				PD55008TR	G3070307		1-	A	F4
Q 5009	TRANSISTOR				DTC144EE TL	G3070075		1-	A	B5
Q 5010	TRANSISTOR				2SC2812-5-TB-E	G3328127E		1-	A	B1
Q 5011	TRANSISTOR				DTC144EE TL	G3070075		1-	A	C5
Q 5012	IC				TC4S66F(TE85R.F)	G1090893		1-	A	C4
Q 5013	IC				TC4S66F(TE85R.F)	G1090893		1-	A	C4
Q 5014	TRANSISTOR				2SC4154-T111-1E	G3341548E		1-	A	C5
Q 5015	FET				PD55025STR	G3070319		1-3	A	E2
Q 5015	FET				PD55025STR	G3070319		4-	A	E2
Q 5016	FET				PD55025STR	G3070319		1-3	A	E4
Q 5016	FET				PD55025STR	G3070319		4-	A	E4
R 5001	CHIP RES.	560	1/16W	5%	RMC1/16 561JATP	J24185561		1-	A	A4
R 5002	CHIP RES.	2.2	1/8W	5%	RMC1/8T 2R2J	J24215229		1-	A	B4
R 5003	CHIP RES.	2.2k	1/16W	5%	RMC1/16 222JATP	J24185222		1-	A	A4
R 5004	CHIP RES.	4.7	1/4W	5%	RMC1/4 4R7JATP	J24245479		1-	A	B4
R 5005	CHIP RES.	22	1/16W	5%	RMC1/16 220JATP	J24185220		1-	A	A4
R 5006	CHIP RES.	180	1/16W	5%	RMC1/16 181JATP	J24185181		1-	A	A4
R 5007	CHIP RES.	2.2k	1/16W	5%	RMC1/16 222JATP	J24185222		1-	A	C5
R 5008	CHIP RES.	220	1/16W	5%	RMC1/16 221JATP	J24185221		1-	A	B4
R 5009	CHIP RES.	1k	1/16W	5%	RMC1/16 102JATP	J24185102		1-	A	A4
R 5010	CHIP RES.	1k	1/16W	5%	RMC1/16 102JATP	J24185102		1-	A	B4
R 5012	CHIP RES.	15	1/16W	5%	RMC1/16 150JATP	J24185150		1-	A	B3
R 5013	CHIP RES.	10	1/2W	5%	RMC1/2 100JCTP	J24275100		1-	A	B4
R 5014	CHIP RES.	82k	1/16W	5%	RMC1/16 823JATP	J24185823		1-	A	B5
R 5015	CHIP RES.	10k	1/16W	5%	RMC1/16 103JATP	J24185103		1-	A	B5
R 5016	CHIP RES.	10k	1/16W	5%	RMC1/16 103JATP	J24185103		1-	A	B2
R 5017	CHIP RES.	51	1/2W	5%	RMC1/2 510JTE	J24275510		1-	A	B3
R 5018	CHIP RES.	10k	1/16W	5%	RMC1/16 103JATP	J24185103		1-	A	B2
R 5019	CHIP RES.	2.2k	1/16W	5%	RMC1/16 222JATP	J24185222		1-	A	B2
R 5020	CHIP RES.	10k	1/16W	5%	RMC1/16 103JATP	J24185103		1-	A	B2

PA Unit (Lot. 1~20)

Parts List

REF	DESCRIPTION	VALUE	V/W	TOL.	MFR'S DESIG	VXSTD P/N	VERS.	LOT	SIDE	LAY ADR
R 5021	CHIP RES.	22	1/10W	5%	RMC1/10T 220J	J24205220		1-	A	A2
R 5022	CHIP RES.	100k	1/16W	5%	RMC1/16 104JATP	J24185104		1-	A	E2
R 5023	CHIP RES.	1k	1/16W	5%	RMC1/16 102JATP	J24185102		1-	A	B5
R 5024	CARBON FILM RES.	22k	1/6W	5%	RD16PJ223 22K	J01225223		1-2	A	B5
R 5024	CHIP RES.	22k	1/16W	5%	RMC1/16 223JATP	J24185223		3-	A	B5
R 5026	CHIP RES.	22k	1/16W	5%	RMC1/16 223JATP	J24185223		1-	A	D3
R 5027	CHIP RES.	1.5k	1/16W	5%	RMC1/16 152JATP	J24185152		1-	A	D3
R 5029	CHIP RES.	10k	1/16W	5%	RMC1/16 103JATP	J24185103		1-	A	E3
R 5030	CHIP RES.	5.6	1W	5%	RMC1 5R6JTE	J24305569		1-	A	C5
R 5031	CEMENT RES.	5.6	5W	10%	ERF-5AK5R6	J30376569		1-61	A	D1
R 5031	CEMENT RES.	5.6	5W	5%	BWR5C5R6J	J30375569		62-	A	D1
R 5033	CHIP RES.	0	1/16W	5%	RMC1/16 000JATP	J24185000		1-	A	E2
R 5034	CHIP RES.	0	1/16W	5%	RMC1/16 000JATP	J24185000		1-	A	D3
R 5035	CHIP RES.	33k	1/16W	5%	RMC1/16 333JATP	J24185333		1-	A	D1
R 5036	CHIP RES.	33k	1/16W	5%	RMC1/16 333JATP	J24185333		1-	A	D5
R 5037	CHIP RES.	150	1/10W	5%	RMC1/10T 151J	J24205151		1-	A	G4
R 5038	CHIP RES.	1k	1/2W	5%	RMC1/2 102JCTP	J24275102		1-	A	E5
R 5039	CHIP RES.	1k	1/2W	5%	RMC1/2 102JCTP	J24275102		1-	A	E1
R 5040	CHIP RES.	100	1/10W	5%	RMC1/10T 101J	J24205101		1-	A	H4
R 5041	CHIP RES.	18	1/2W	5%	RMC1/2 180JTE	J24275180		1-	A	E5
R 5042	CHIP RES.	18	1/2W	5%	RMC1/2 180JTE	J24275180		1-	A	E2
R 5043	METAL FILM RES.	1	3W	5%	ERX-3SJ1R0 1	J22359044		1-	A	D3
R 5044	CHIP RES.	27k	1/16W	5%	RMC1/16 273JATP	J24185273		1-	A	G5
R 5045	CHIP RES.	10k	1/10W	5%	RMC1/10T 103J	J24205103		1-2	A	A3
R 5045	CHIP RES.	10k	1/16W	5%	RMC1/16 103JATP	J24185103		3-	A	A3
R 5046	CHIP RES.	10k	1/16W	5%	RMC1/16 103JATP	J24185103		1-	A	G3
R 5047	CHIP RES.	10k	1/16W	5%	RMC1/16 103JATP	J24185103		1-	A	G3
R 5048	METAL FILM RES.	1	3W	5%	ERX-3SJ1R0 1	J22359044		1-	A	D3
R 5049	CHIP RES.	47k	1/16W	5%	RMC1/16 473JATP	J24185473		1-	A	G1
R 5050	CHIP RES.	4.7k	1/16W	5%	RMC1/16 472JATP	J24185472		1-	A	B4
R 5051	CHIP RES.	1.2k	1/16W	5%	RMC1/16 122JATP	J24185122		1-	A	C5
R 5052	CHIP RES.	10k	1/16W	5%	RMC1/16 103JATP	J24185103		1-	A	C4
R 5055	CHIP RES.	0	1/16W	5%	RMC1/16 000JATP	J24185000		3-	A	A5
R 5057	CHIP RES.	1.8k	1/10W	5%	RMC1/10T 182J	J24205182		1-2	A	G5
R 5057	CHIP RES.	1.8k	1/16W	5%	RMC1/16 182JATP	J24185182		3-	A	G5
R 5060	CARBON FILM RES.	150k	1/6W	5%	RD16PJ154 150K	J01225154		1-2	A	B1
R 5060	CHIP RES.	150k	1/16W	5%	RMC1/16 154JATP	J24185154		3-	A	B1
RL5001	RELAY		DC12V		ACP131 DC12V	M1190152		1-	A	A2
S 5001	SLIDE SWITCH				SSSS912N-2A-OR	N6090094		1-	A	F4
TH5001	THERMISTOR				157-203-55009TP	G9090045		1-	A	E5
TH5002	THERMISTOR				157-502-53002TP	G9090049		1-	A	G4
VR5001	POT.	2.2k			RH03A3AJ3X 2.2K	J51807222		1-	A	C5
VR5002	POT.	2.2k			RH03A3AJ3X 2.2K	J51807222		1-	A	C4
	SHIELD PLATE				(PA)	RA0506200		1-22		
	SHIELD PLATE				(PA)	RA0506200		23-		
	GASKET				L=10	RA0515000		1-37		
	GASKET				L=10	RA0515000		38-		
	LEAF SPRING					R0120250		1-		
	LEAF SPRING					R0120250		4-		
	LEAF SPRING					R0140031		4-		

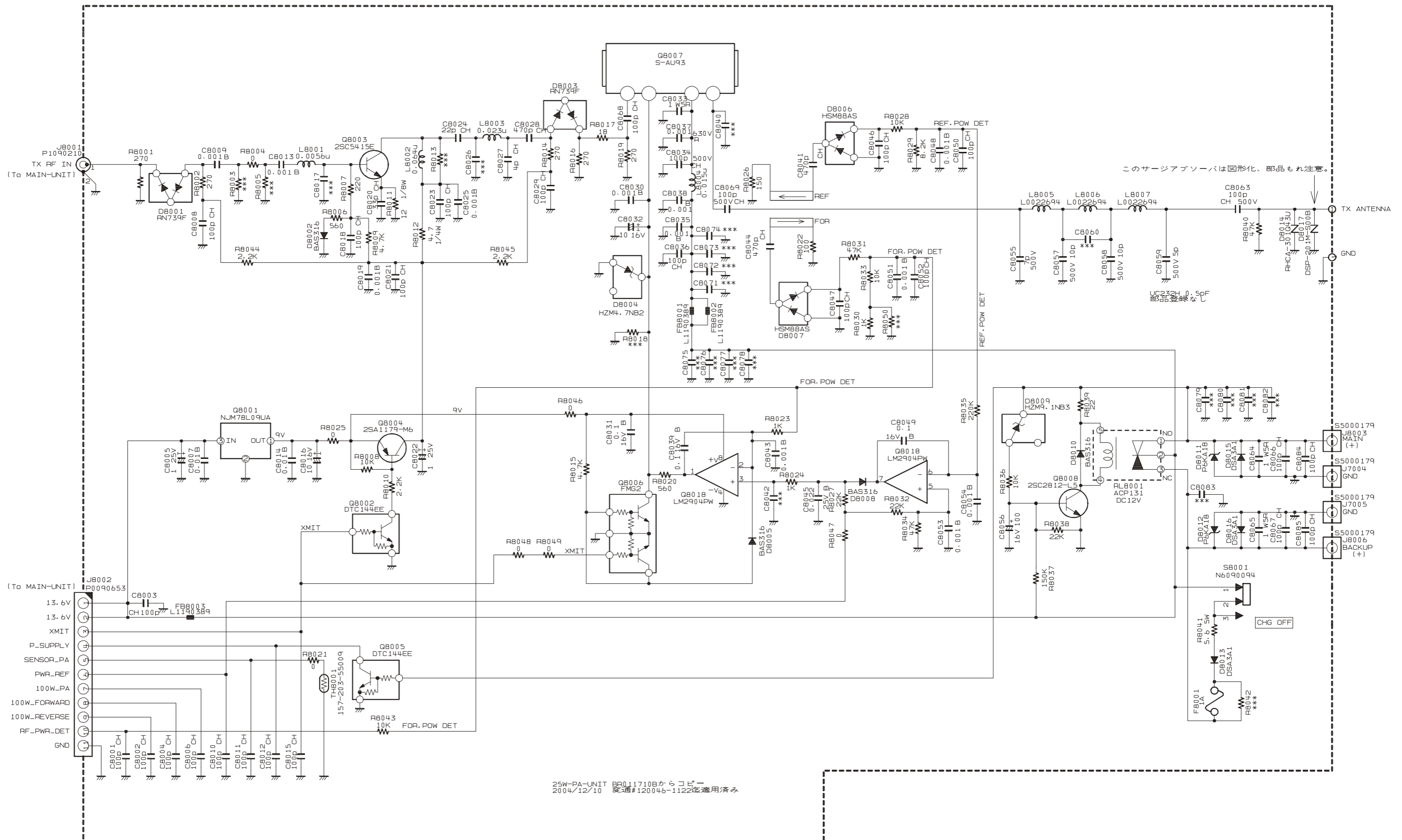

PA-2 Unit (Lot. 21~)

Note:

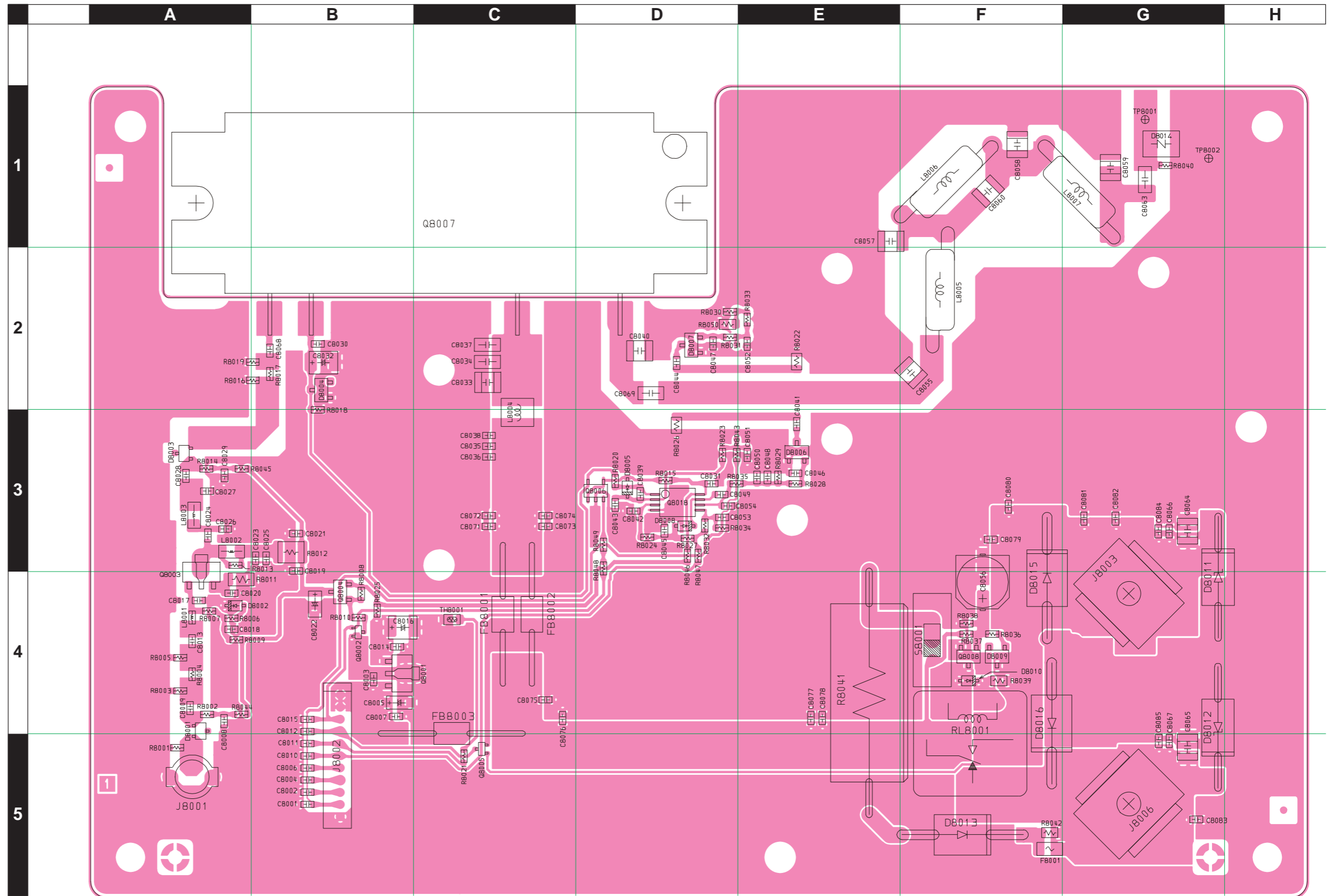
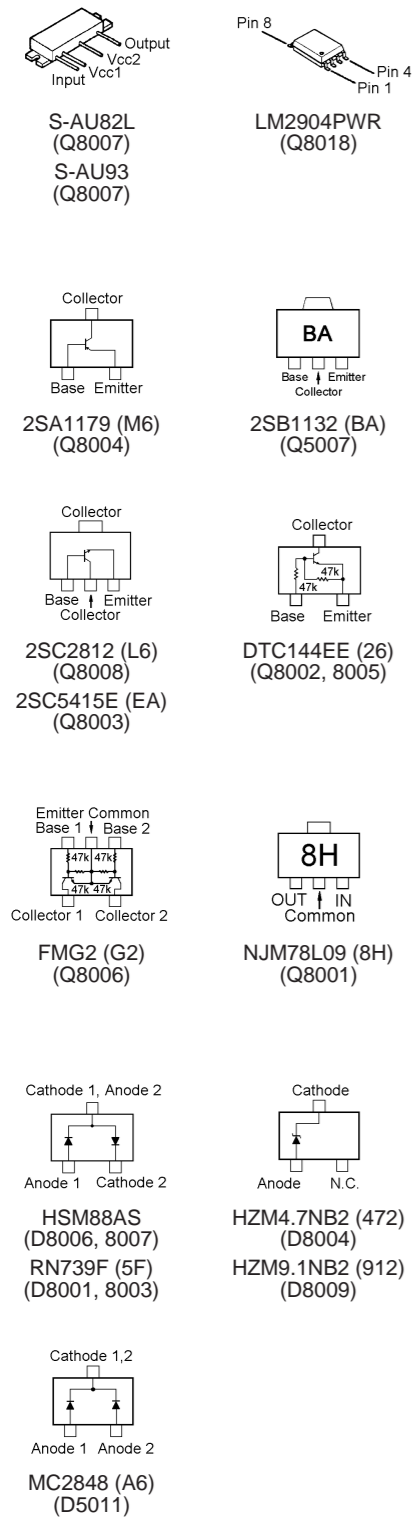

PA-2 Unit (Lot. 21~)

Parts Layout (Side B)

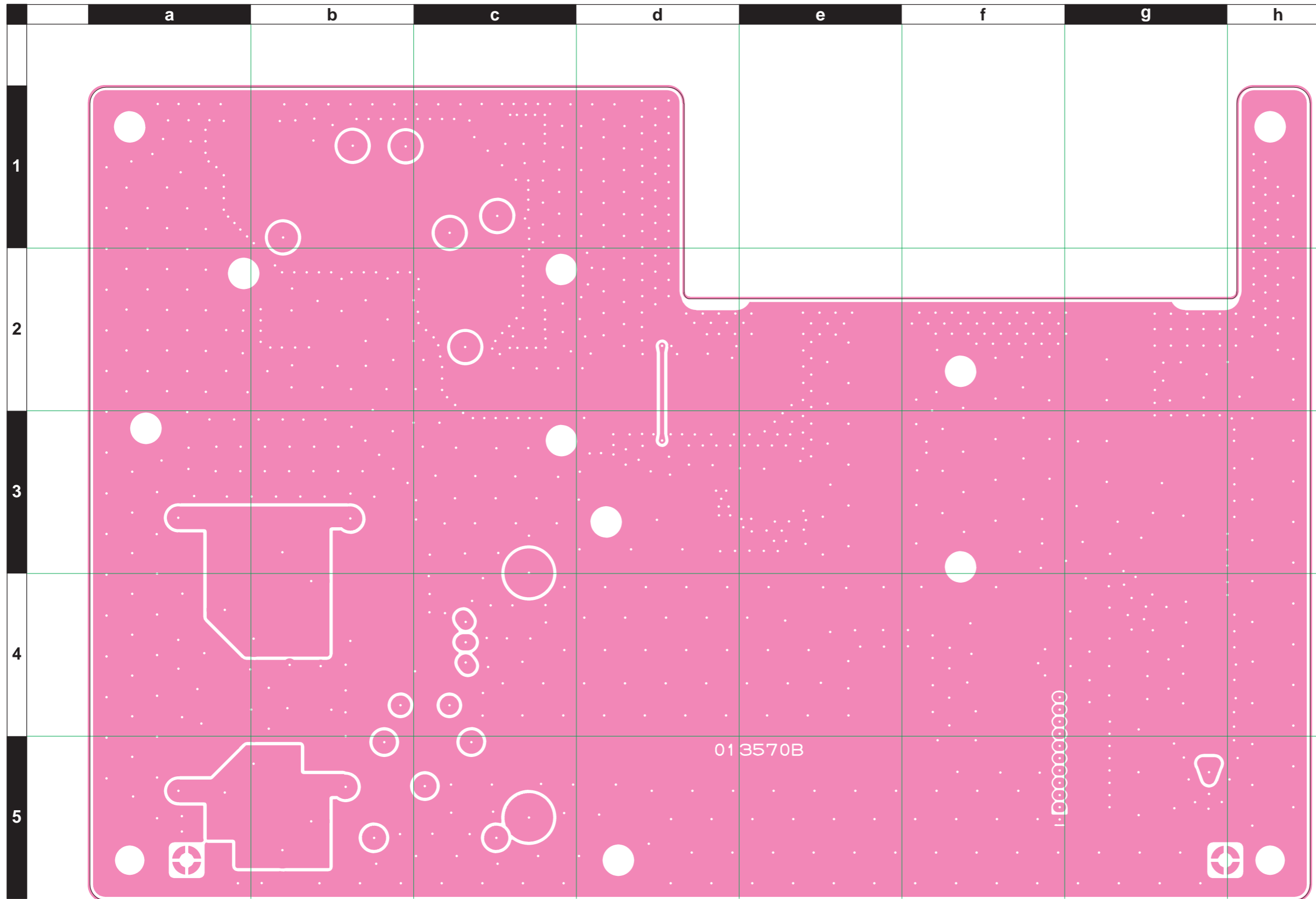

REF	DESCRIPTION	VALUE	V/W	TOL.	MFR'S DESIG	VXSTD P/N	VERS.	LOT	SIDE	LAY ADR
PCB with Components (w/o Q8007 PA Module)						CB3195001 CB3195002	VER. A VER. D			
C 8001	CHIP CAP.	100pF	50V	CH	GRM1882C1H101JA01D	K22174235		1-	A	B5
C 8002	CHIP CAP.	100pF	50V	CH	GRM1882C1H101JA01D	K22174235		1-	A	B5
C 8003	CHIP CAP.	100pF	50V	CH	GRM1882C1H101JA01D	K22174235		1-	A	B4
C 8004	CHIP CAP.	100pF	50V	CH	GRM1882C1H101JA01D	K22174235		1-	A	B5
C 8005	CHIP TA.CAP.	1uF	25V		TEESVA1E105M8R	K78140013		1-	A	B4
C 8006	CHIP CAP.	100pF	50V	CH	GRM1882C1H101JA01D	K22174235		1-	A	B5
C 8007	CHIP CAP.	0.01uF	50V	B	GRM188B11H103KA01D	K22174823		1-	A	B4
C 8008	CHIP CAP.	100pF	50V	CH	GRM1882C1H101JA01D	K22174235		1-	A	A4
C 8009	CHIP CAP.	0.001uF	50V	B	GRM188B11H102KA01D	K22174821		1-	A	A4
C 8010	CHIP CAP.	100pF	50V	CH	GRM1882C1H101JA01D	K22174235		1-	A	B5
C 8011	CHIP CAP.	100pF	50V	CH	GRM1882C1H101JA01D	K22174235		1-	A	B5
C 8012	CHIP CAP.	100pF	50V	CH	GRM1882C1H101JA01D	K22174235		1-	A	B4
C 8013	CHIP CAP.	0.001uF	50V	B	GRM188B11H102KA01D	K22174821		1-	A	A4
C 8014	CHIP CAP.	0.01uF	50V	B	GRM188B11H103KA01D	K22174823		1-	A	B4
C 8015	CHIP CAP.	100pF	50V	CH	GRM1882C1H101JA01D	K22174235		1-	A	B4
C 8016	CHIP TA.CAP.	10uF	16V		TEESVB21C106M8R	K78120025		1-	A	B4
C 8018	CHIP CAP.	100pF	50V	CH	GRM1882C1H101JA01D	K22174235		1-	A	A4
C 8019	CHIP CAP.	0.001uF	50V	B	GRM188B11H102KA01D	K22174821		1-	A	B3
C 8020	CHIP CAP.	33pF	50V	CH	GRM1882C1H330JA01D	K22174223		1-	A	A4
C 8021	CHIP CAP.	100pF	50V	CH	GRM1882C1H101JA01D	K22174235		1-	A	B3
C 8022	CHIP TA.CAP.	1uF	25V		TEESVA1E105M8R	K78140013		1-	A	B4
C 8023	CHIP CAP.	100pF	50V	CH	GRM1882C1H101JA01D	K22174235		1-	A	B3
C 8024	CHIP CAP.	22pF	50V	CH	GRM1882C1H220JA01D	K22174219		1-	A	A3
C 8025	CHIP CAP.	0.001uF	50V	B	GRM188B11H102KA01D	K22174821		1-	A	B3
C 8027	CHIP CAP.	4pF	50V	CH	GRM1882C1H4R0CZ01D	K22174205		1-	A	A3
C 8028	CHIP CAP.	470pF	50V	CH	GRM1882C1H471JA01D	K22174249		1-	A	A3
C 8029	CHIP CAP.	100pF	50V	CH	GRM1882C1H101JA01D	K22174235		1-	A	A3
C 8030	CHIP CAP.	0.001uF	50V	B	GRM188B11H102KA01D	K22174821		1-	A	B2
C 8031	CHIP CAP.	0.1uF	16V	B	GRM188B11C104KA01D	K22124805		1-	A	D3
C 8032	CHIP TA.CAP.	10uF	16V		TEESVB21C106M8R	K78120025		1-	A	B2
C 8033	CHIP CAP.	1uF	50V	B	GRM32RB11H105KA01L	K22175801		1-	A	C2
C 8034	CHIP CAP.	100pF	500V	CH	CF316CH101J500AT	K22271267		1-	A	C2
C 8035	CHIP CAP.	0.001uF	50V	B	GRM188B11H102KA01D	K22174821		1-	A	C3
C 8036	CHIP CAP.	100pF	50V	CH	GRM1882C1H101JA01D	K22174235		1-	A	C3
C 8037	CHIP CAP.	0.001uF	630V	R	GRM31BR32J102KY01L	K22281801		1-84	A	C2
C 8037	CHIP CAP.	0.001uF	630V	UJ	GRM31A7U2J102JW31D	K22281803		85-	A	C2
C 8038	CHIP CAP.	0.001uF	50V	B	GRM188B11H102KA01D	K22174821		1-	A	C3
C 8039	CHIP CAP.	0.1uF	16V	B	GRM188B11C104KA01D	K22124805		1-	A	D3
C 8041	CHIP CAP.	470pF	50V	CH	GRM1882C1H471JA01D	K22174249		1-	A	E3
C 8043	CHIP CAP.	0.001uF	50V	B	GRM188B11H102KA01D	K22174821		1-	A	D3
C 8044	CHIP CAP.	470pF	50V	CH	GRM1882C1H471JA01D	K22174249		1-	A	D3
C 8045	CHIP CAP.	0.022uF	25V	B	GRM39B223K25PT	K22144807		1-47	A	D2
C 8045	CHIP CAP.	0.022uF	50V	B	GRM188B11H223KA01D	K22174839		48-	A	D3
C 8046	CHIP CAP.	100pF	50V	CH	GRM1882C1H101JA01D	K22174235		1-	A	E3
C 8047	CHIP CAP.	100pF	50V	CH	GRM1882C1H101JA01D	K22174235		1-	A	D2
C 8048	CHIP CAP.	0.001uF	50V	B	GRM188B11H102KA01D	K22174821		1-	A	E3
C 8049	CHIP CAP.	0.1uF	16V	B	GRM188B11C104KA01D	K22124805		1-	A	D3
C 8050	CHIP CAP.	100pF	50V	CH	GRM1882C1H101JA01D	K22174235		1-	A	E3
C 8051	CHIP CAP.	0.001uF	50V	B	GRM188B11H102KA01D	K22174821		1-	A	E3
C 8052	CHIP CAP.	100pF	50V	CH	GRM1882C1H101JA01D	K22174235		1-	A	E2
C 8053	CHIP CAP.	0.001uF	50V	B	GRM188B11H102KA01D	K22174821		1-	A	D3
C 8054	CHIP CAP.	0.001uF	50V	B	GRM188B11H102KA01D	K22174821		1-	A	D3
C 8055	FILM CAP.	7pF	500V		UC232H0070D-T	K33279046		1-52	A	F2
C 8055	FILM CAP.	7pF	500V		UC232H0070D-T	K33279046	VER. D	53-	A	F2
C 8056	AL.ELECTRO.CAP.	100uF	16V		EEE1CA101WP	K48120012		1-	A	F4
C 8057	FILM CAP.	10pF	500V		UC232H0100D-T	K33279019		1-	A	E1
C 8058	FILM CAP.	10pF	500V		UC232H0100D-T	K33279019		1-	A	F1
C 8059	FILM CAP.	5pF	500V		UC232H0050D-T	K33279010		1-	A	G1
C 8060	FILM CAP.	2pF	500V		UC232H0020D-T	K33279043	VER. A	53-	A	F1
C 8063	CHIP CAP.	100pF	500V		CF316CH101J500AT	K22271267		1-	A	G1
C 8064	CHIP CAP.	1uF	50V	B	GRM32RB11H105KA01L	K22175801		1-	A	G3
C 8065	CHIP CAP.	1uF	50V	B	GRM32RB11H105KA01L	K22175801		1-	A	G5
C 8066	CHIP CAP.	100pF	50V	CH	GRM1882C1H101JA01D	K22174235		1-	A	G3
C 8067	CHIP CAP.	100pF	50V	CH	GRM1882C1H101JA01D	K22174235		1-	A	G5
C 8068	CHIP CAP.	100pF	50V	CH	GRM1882C1H101JA01D	K22174235		1-	A	B2
C 8069	CHIP CAP.	100pF	500V	CH	CF316CH101J500AT	K22271267		1-	A	D2
C 8084	CHIP CAP.	100pF	50V	CH	GRM1882C1H101JA01D	K22174235		1-	A	G3
C 8085	CHIP CAP.	100pF	50V	CH	GRM1882C1H101JA01D	K22174235		1-	A	G5
C 8086	FILM CAP.	1pF	500V		UC232H0010D-T	K33279036	VER. D	48-	A	
D 8001	DIODE				RN739F T106	G2070626		1-	A	A4
D 8002	DIODE				BAS316	G2070716		1-	A	A4

PA-2 Unit (Lot. 21~)

Parts List

REF	DESCRIPTION	VALUE	V/W	TOL.	MFR'S DESIG	VXSTD P/N	VERS.	LOT	SIDE	LAY ADR
D 8003	DIODE				RN739F T106	G2070626		1-	A	A3
D 8004	DIODE				HZM4.7NB2 TR-E	G2070782		1-102	A	B2
D 8004	DIODE				HZM5.6NB2 TR-E	G2070722	VER. A	103-	A	B2
D 8004	DIODE				HZM4.7NB2 TR-E	G2070782	VER. D	103-	A	B2
D 8005	DIODE				BAS316	G2070716		1-	A	D3
D 8006	DIODE				HSM88AS TR-E	G2070170		1-	A	E3
D 8007	DIODE				HSM88AS TR-E	G2070170		1-	A	D2
D 8008	DIODE				BAS316	G2070716		1-	A	D3
D 8009	DIODE				HZM9.1NB3 TR-E	G2070404		1-	A	F4
D 8010	DIODE				BAS316	G2070716		1-	A	F4
D 8011	SURGE ABSORBER				P6KA18A-E3	Q9000721		1-114	A	G3
D 8011	SURGE ABSORBER				P6KA18A-HE3	Q9000721A		115-	A	G3
D 8012	SURGE ABSORBER				P6KA18A-E3	Q9000721		1-114	A	G5
D 8012	SURGE ABSORBER				P6KA18A-HE3	Q9000721A		115-	A	G5
D 8013	DIODE				DSA3A1	G2090445		1-	A	F5
D 8014	SURGE ABSORBER				RHCA-301Q43U	Q9000827		1-	A	G1
D 8015	DIODE				DSA3A1	G2090445		1-	A	F3
D 8016	DIODE				DSA3A1	G2090445		1-	A	F5
D 8017	SURGE ABSORBER				DSP201M-S00B	Q9000375		1-		
F 8001	CHIP FUSE	1A			R429 001	Q0000089		1-71	A	F5
F 8001	CHIP FUSE	1A			0466001.NR	Q0000171		72-	A	F5
FB8001	M.RFC				FBA03VA450AB-00	L1190389		1-	A	C4
FB8002	M.RFC				FBA03VA450AB-00	L1190389		1-	A	C4
FB8003	M.RFC				FBA03VA450AB-00	L1190389		1-	A	C5
J 8001	CONNECTOR				TMP-J01X-V6	P1090210		1-	A	A5
J 8002	CONNECTOR				IL-Y-11P-S15T2-E	P0090653		1-	A	B4
J 8003	TERMINAL				Y106	S5000179		1-	A	G4
J 8006	TERMINAL				Y106	S5000179		1-	A	G5
L 8001	M.RFC	0.0056uH			HK1608 5N6S-T	L1690513		1-	A	A4
L 8002	CHIP COIL	0.064uH			LQW31HN64NJ03L	L1690258		1-	A	A3
L 8003	CHIP COIL	0.023uH			LQW31HN23NJ03L	L1690252		1-	A	A3
L 8004	COIL	0.015uH			AS0803-15NK	L0022536		1-90	A	C3
L 8004	COIL	0.015uH			TAS0803-15NK	L0023103		91-	A	C3
L 8005	COIL C1				1.0T6.0D1.6PEW R	L0022694		1-	A	F2
L 8006	COIL C1				1.0T6.0D1.6PEW R	L0022694		1-	A	E1
L 8007	COIL C1				1.0T6.0D1.6PEW R	L0022694		1-	A	F1
Q 8001	IC				NJM78L09UA-TE2	G1091305		1-	A	B4
Q 8002	TRANSISTOR				DTC144EE TL	G3070075		1-	A	B4
Q 8003	TRANSISTOR				2SC5415E-TD-E	G3354158E		1-130	A	A3
Q 8003	TRANSISTOR				2SC5415AE-TD-E	G3070426		131-	A	A3
Q 8004	TRANSISTOR				2SA1179N6-CPA-TB	G3111797F		1-	A	B4
Q 8005	TRANSISTOR				DTC144EE TL	G3070075		1-	A	C5
Q 8006	TRANSISTOR				FMG2 T148	G3070015		1-	A	D3
Q 8007	IC				S-AU93	G1094180	VER. D	1-23	A	A1
Q 8007	IC				S-AU93	G1094203	VER. D	24-47	A	A1
Q 8007	IC				S-AU93A(VX.Q)	G1094616	VER. D	48-104	A	A1
Q 8007	IC				RA60H4452M1	G1094520	VER. D	105-	A	A1
Q 8007	IC				S-AU82L	G1093918	VER. A	1-52	A	A1
Q 8007	IC				S-AU82AL(VX.Q)	G1094680	VER. A	53-102	A	A1
Q 8007	IC				RA60H4047M1-101	G1094556	VER. A	103-	A	A1
Q 8008	TRANSISTOR				2SC2812-5-TB-E	G3328127E		1-	A	F4
Q 8018	IC				LM2904PWR	G1094010		1-	A	D3
R 8001	CHIP RES.	270	1/16W	5%	RMC1/16 271JATP	J24185271		1-	A	A5
R 8002	CHIP RES.	270	1/16W	5%	RMC1/16 271JATP	J24185271		1-	A	A4
R 8004	CHIP RES.	0	1/16W	5%	RMC1/16 000JATP	J24185000		1-	A	A4
R 8006	CHIP RES.	560	1/16W	5%	RMC1/16 561JATP	J24185561		1-	A	A4
R 8007	CHIP RES.	220	1/16W	5%	RMC1/16 221JATP	J24185221		1-	A	A4
R 8008	CHIP RES.	10k	1/16W	5%	RMC1/16 103JATP	J24185103		1-	A	B4
R 8009	CHIP RES.	4.7k	1/16W	5%	RMC1/16 472JATP	J24185472		1-	A	A4
R 8010	CHIP RES.	2.2k	1/16W	5%	RMC1/16 222JATP	J24185222		1-	A	B4
R 8011	CHIP RES.	10	1/8W	5%	RMC1/8T 100J	J24215100	VER. A	1-	A	A4
R 8011	CHIP RES.	12	1/8W	5%	RMC1/8T 120J	J24215120	VER. D	1-	A	A4
R 8012	CHIP RES.	4.7	1/4W	5%	RMC1/4 4R7JATP	J24245479		1-	A	B3
R 8014	CHIP RES.	270	1/16W	5%	RMC1/16 271JATP	J24185271		1-	A	A3
R 8015	CHIP RES.	12k	1/16W	5%	RMC1/16 123JATP	J24185123	VER. A	1-22	A	D3
R 8015	CHIP RES.	4.7k	1/16W	5%	RMC1/16 472JATP	J24185472	VER. D	1-22	A	D3
R 8015	CHIP RES.	4.7k	1/16W	5%	RMC1/16 472JATP	J24185472		23-	A	D3
R 8016	CHIP RES.	270	1/16W	5%	RMC1/16 271JATP	J24185271		1-	A	B2
R 8017	CHIP RES.	0	1/16W	5%	RMC1/16 000JATP	J24185000	VER. A	1-	A	B2
R 8017	CHIP RES.	18	1/16W	5%	RMC1/16 180JATP	J24185180	VER. D	1-	A	B2
R 8019	CHIP RES.	270	1/16W	5%	RMC1/16 271JATP	J24185271	VER. D	1-	A	B2
R 8020	CHIP RES.	560	1/16W	5%	RMC1/16 561JATP	J24185561		1-	A	D3
R 8021	CHIP RES.	0	1/16W	5%	RMC1/16 000JATP	J24185000		1-	A	C5

PA-2 Unit (Lot. 21~)

Parts List

REF	DESCRIPTION	VALUE	V/W	TOL.	MFR'S DESIG	VXSTD P/N	VERS.	LOT	SIDE	LAY ADR
R 8022	CHIP RES.	100	1/10W	5%	RMC1/10T 101J	J24205101		1-	A	E2
R 8023	CHIP RES.	1k	1/16W	5%	RMC1/16 102JATP	J24185102		1-	A	D3
R 8024	CHIP RES.	1k	1/16W	5%	RMC1/16 102JATP	J24185102		1-	A	D3
R 8025	CHIP RES.	0	1/16W	5%	RMC1/16 000JATP	J24185000		1-	A	B4
R 8026	CHIP RES.	150	1/10W	5%	RMC1/10T 151J	J24205151		1-	A	D3
R 8027	CHIP RES.	22k	1/16W	5%	RMC1/16 223JATP	J24185223		1-	A	D3
R 8028	CHIP RES.	10k	1/16W	5%	RMC1/16 103JATP	J24185103		1-	A	E3
R 8029	CHIP RES.	8.2k	1/16W	5%	RMC1/16 822JATP	J24185822		1-	A	E3
R 8030	CHIP RES.	1k	1/16W	5%	RMC1/16 102JATP	J24185102		1-	A	D2
R 8031	CHIP RES.	47k	1/16W	5%	RMC1/16 473JATP	J24185473		1-	A	D2
R 8032	CHIP RES.	22k	1/16W	5%	RMC1/16 223JATP	J24185223		1-	A	D3
R 8033	CHIP RES.	10k	1/16W	5%	RMC1/16 103JATP	J24185103		1-	A	E2
R 8034	CHIP RES.	47k	1/16W	5%	RMC1/16 473JATP	J24185473		1-	A	D3
R 8035	CHIP RES.	220k	1/16W	5%	RMC1/16 224JATP	J24185224		1-	A	D3
R 8036	CHIP RES.	10k	1/16W	5%	RMC1/16 103JATP	J24185103		1-	A	F4
R 8037	CHIP RES.	150k	1/16W	5%	RMC1/16 154JATP	J24185154		1-	A	F4
R 8038	CHIP RES.	22k	1/16W	5%	RMC1/16 223JATP	J24185223		1-	A	F4
R 8039	CHIP RES.	22	1/10W	5%	RMC1/10T 220J	J24205220		1-	A	F4
R 8040	CHIP RES.	47k	1/16W	5%	RMC1/16 473JATP	J24185473		1-	A	G1
R 8041	CEMENT RES.	5.6	5W	10%	ERF-5AK5R6	J30376569		1-61	A	E5
R 8041	CEMENT RES.	5.6	5W	5%	BWR5C5R6J	J30375569		62-	A	E5
R 8043	CHIP RES.	10k	1/16W	5%	RMC1/16 103JATP	J24185103		1-	A	D3
R 8044	CHIP RES.	2.2k	1/16W	5%	RMC1/16 222JATP	J24185222		1-	A	A4
R 8045	CHIP RES.	2.2k	1/16W	5%	RMC1/16 222JATP	J24185222		1-	A	A3
R 8046	CHIP RES.	0	1/16W	5%	RMC1/16 000JATP	J24185000		1-	A	D3
R 8047	CHIP RES.	0	1/16W	5%	RMC1/16 000JATP	J24185000		1-	A	D3
R 8048	CHIP RES.	0	1/16W	5%	RMC1/16 000JATP	J24185000		1-	A	D3
R 8049	CHIP RES.	0	1/16W	5%	RMC1/16 000JATP	J24185000		1-	A	D3
RL8001	RELAY		DC12V		ACP131 DC12V	M1190152		1-	A	F5
S 8001	SLIDE SWITCH				SSSS912N-2A-OR	N6090094		1-	A	F4
TH8001	THERMISTOR				157-203-55009TP	G9090045		1-	A	C4
	SHIELD PLATE				PA	R0124501		1-		
	BINDING HEAD SCREW				M3X10NI	U20310002		1-		
	BINDING HEAD SCREW				M3X10NI	U20310002		1-		
	TERMINAL				B4 AG M3	Q6000114		1-		
	TERMINAL				B4 AG M3	Q6000114		1-		
	GASKET				L=50	RA0650800		1-		

PA-2 Unit (Lot. 21~)

Note

REG Unit

Circuit Diagram

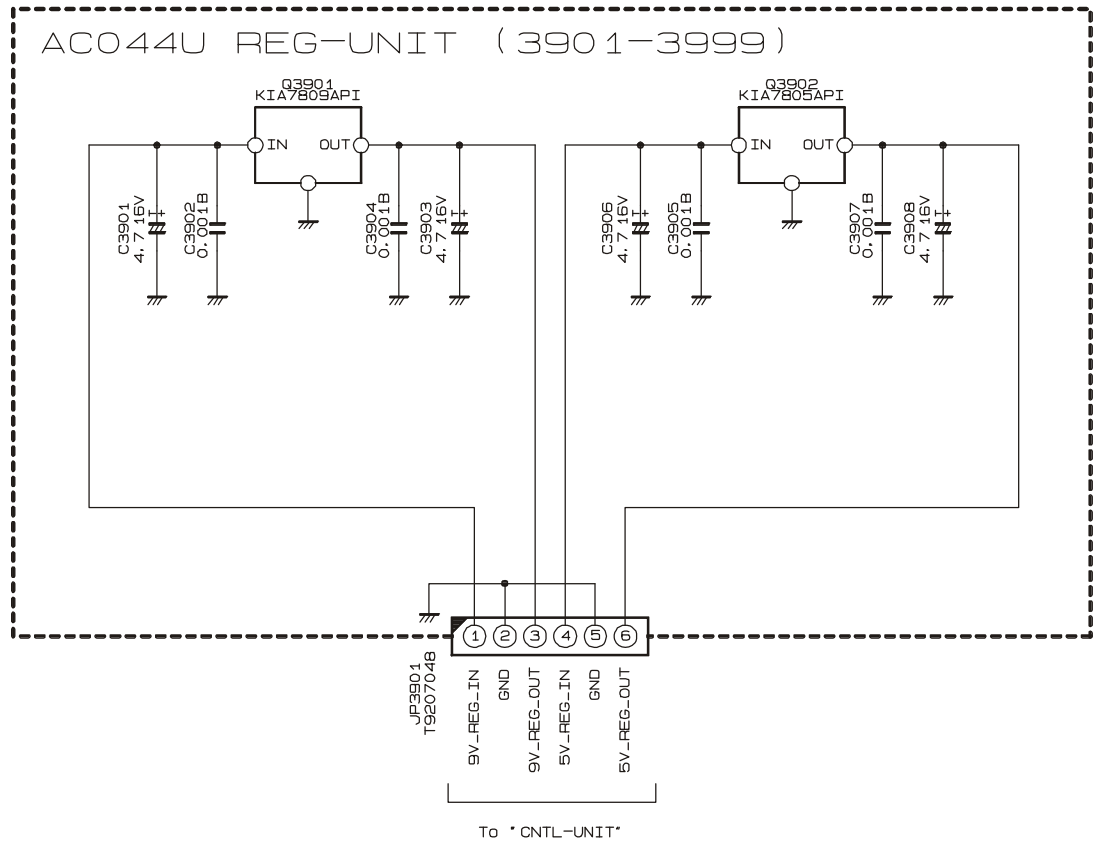

REG Unit

Parts Layout

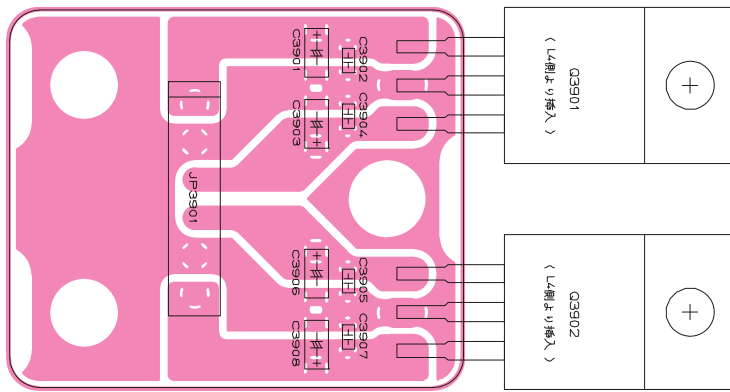

Side A

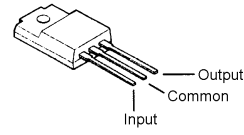

KIA7809API
(Q3901, 3902)

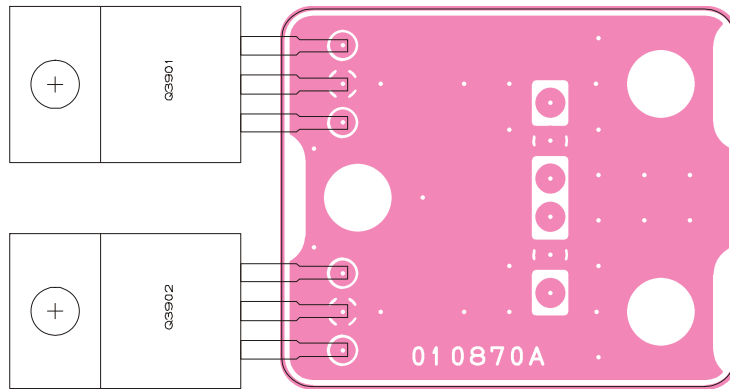

Side B

Parts List

REF	DESCRIPTION	VALUE	V/W	TOL.	MFR'S DESIG	VXSTD P/N	VERS.	LOT	SIDE	LAY ADR
PCB with Components (w/o Q3901 & Q3902 REGULATOR IC)						CB2565001				
C 3901	CHIPTA.CAP.	4.7uF	16V		TEESVA1C475M8R	K78120031		1-55	A	
C 3901	CHIPTA.CAP.	4.7uF	20V		TEESVA1D475M8R	K78130048		56-62	A	
C 3901	AL.ELECTRO.CAP.	4.7uF	35V		RC2-35V4R7MD1#-T58	K46160004		63-	A	
C 3902	CHIPCAP.	0.001uF	50V	B	GRM188B11H102KA01D	K22174821		1-	A	
C 3903	CHIPTA.CAP.	4.7uF	16V		TEESVA1C475M8R	K78120031		1-	A	
C 3904	CHIPCAP.	0.001uF	50V	B	GRM188B11H102KA01D	K22174821		1-	A	
C 3905	CHIPCAP.	0.001uF	50V	B	GRM188B11H102KA01D	K22174821		1-	A	
C 3906	CHIPTA.CAP.	4.7uF	16V		TEESVA1C475M8R	K78120031		1-55	A	
C 3906	CHIPTA.CAP.	4.7uF	20V		TEESVA1D475M8R	K78130048		56-	A	
C 3907	CHIPCAP.	0.001uF	50V	B	GRM188B11H102KA01D	K22174821		1-	A	
C 3908	CHIPTA.CAP.	4.7uF	16V		TEESVA1C475M8R	K78120031		1-	A	
JP3901	WIRE ASSY				AC044N/U	T9207048		1-	A	
Q 3901	IC				KIA7809API	G1093165		1-	B	
Q 3902	IC				KIA7805API	G1093163		1-	B	

SUB Unit (Lot. 1~2)

Circuit Diagram

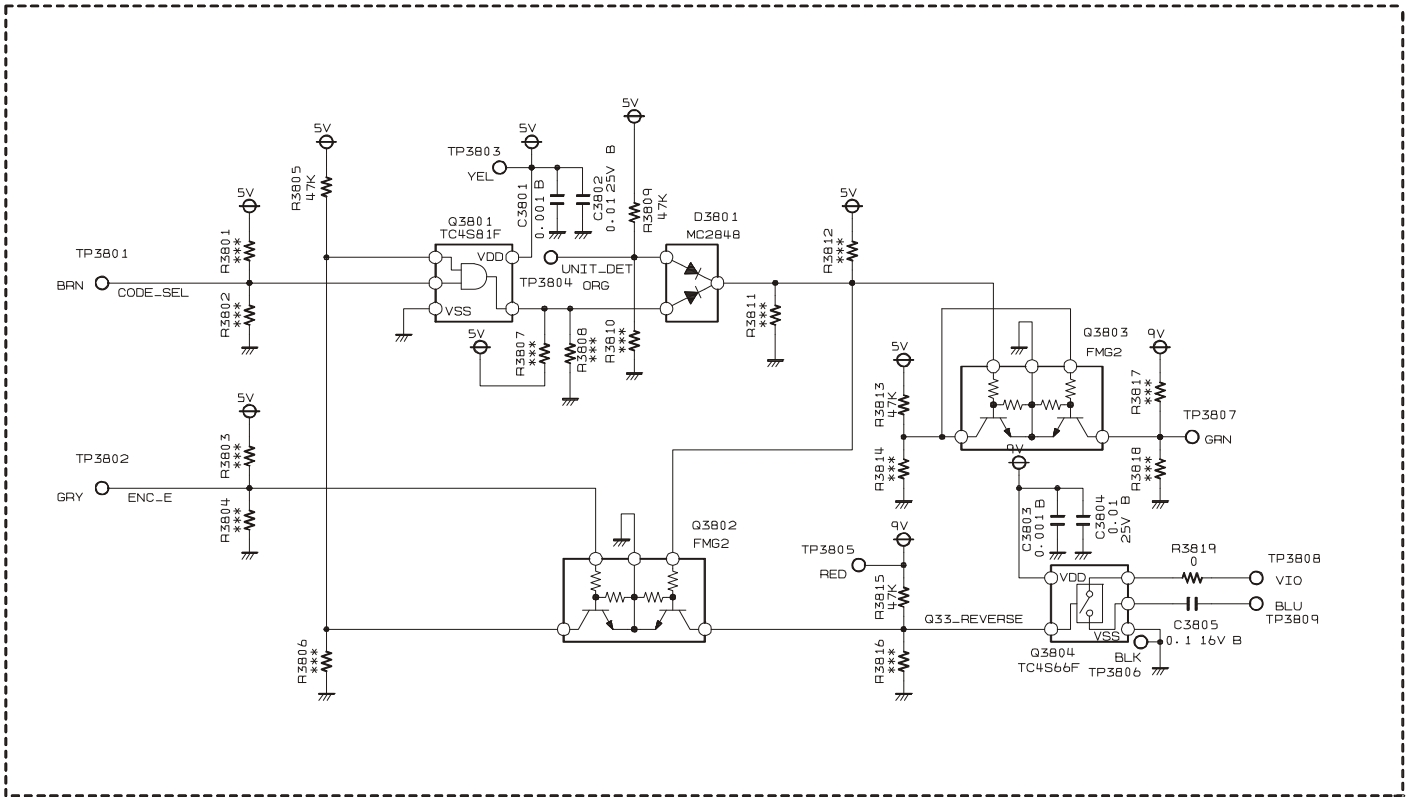

SUB Unit (Lot. 1~2)

Parts Layout

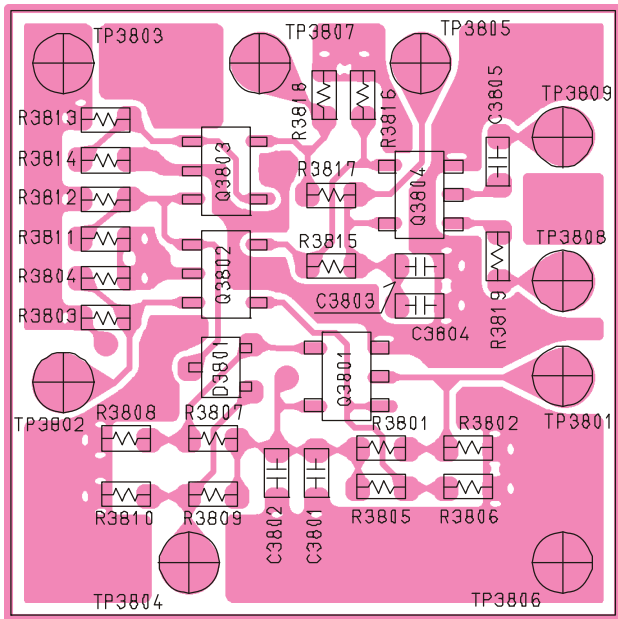

Side A



Side B

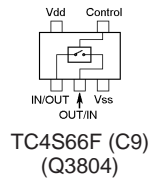
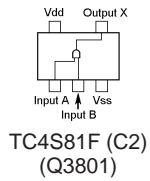
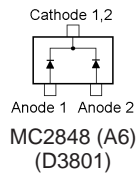
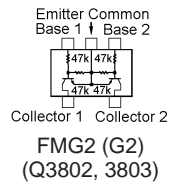

Parts List

REF	DESCRIPTION	VALUE	V/W	TOL.	MFR'S DESIG	VXSTD P/N	VERS.	LOT	SIDE	LAY ADR
C 3801	CHIP CAP.	0.001uF	50V	B	GRM188B11H102KA01D	K22174809		1-	A	
C 3802	CHIP CAP.	0.01uF	25V	B	GRM39B103M25PT	K22144802		1-	A	
C 3803	CHIP CAP.	0.001uF	50V	B	GRM188B11H102KA01D	K22174809		1-	A	
C 3804	CHIP CAP.	0.01uF	25V	B	GRM39B103M25PT	K22144802		1-	A	
C 3805	CHIP CAP.	0.1uF	16V	B	GRM188B11C104KA01D	K22124805		1-	A	
D 3801	DIODE				MC2848-T111-1	G2070694		1-	A	
Q 3801	IC				TC4S81F(TE85R.F)	G1090895		1-	A	
Q 3802	TRANSISTOR				FMG2 T148	G3070015		1-	A	
Q 3803	TRANSISTOR				FMG2 T148	G3070015		1-	A	
Q 3804	IC				TC4S66F(TE85R.F)	G1090893		1-	A	
R 3805	CHIP RES.	47k	1/16W	5%	RMC1/16 473JATP	J24185473		1-	A	
R 3809	CHIP RES.	47k	1/16W	5%	RMC1/16 473JATP	J24185473		1-	A	
R 3813	CHIP RES.	47k	1/16W	5%	RMC1/16 473JATP	J24185473		1-	A	
R 3815	CHIP RES.	47k	1/16W	5%	RMC1/16 473JATP	J24185473		1-	A	
R 3819	CHIP RES.	0	1/16W	5%	RMC1/16 000JATP	J24185000		1-	A	

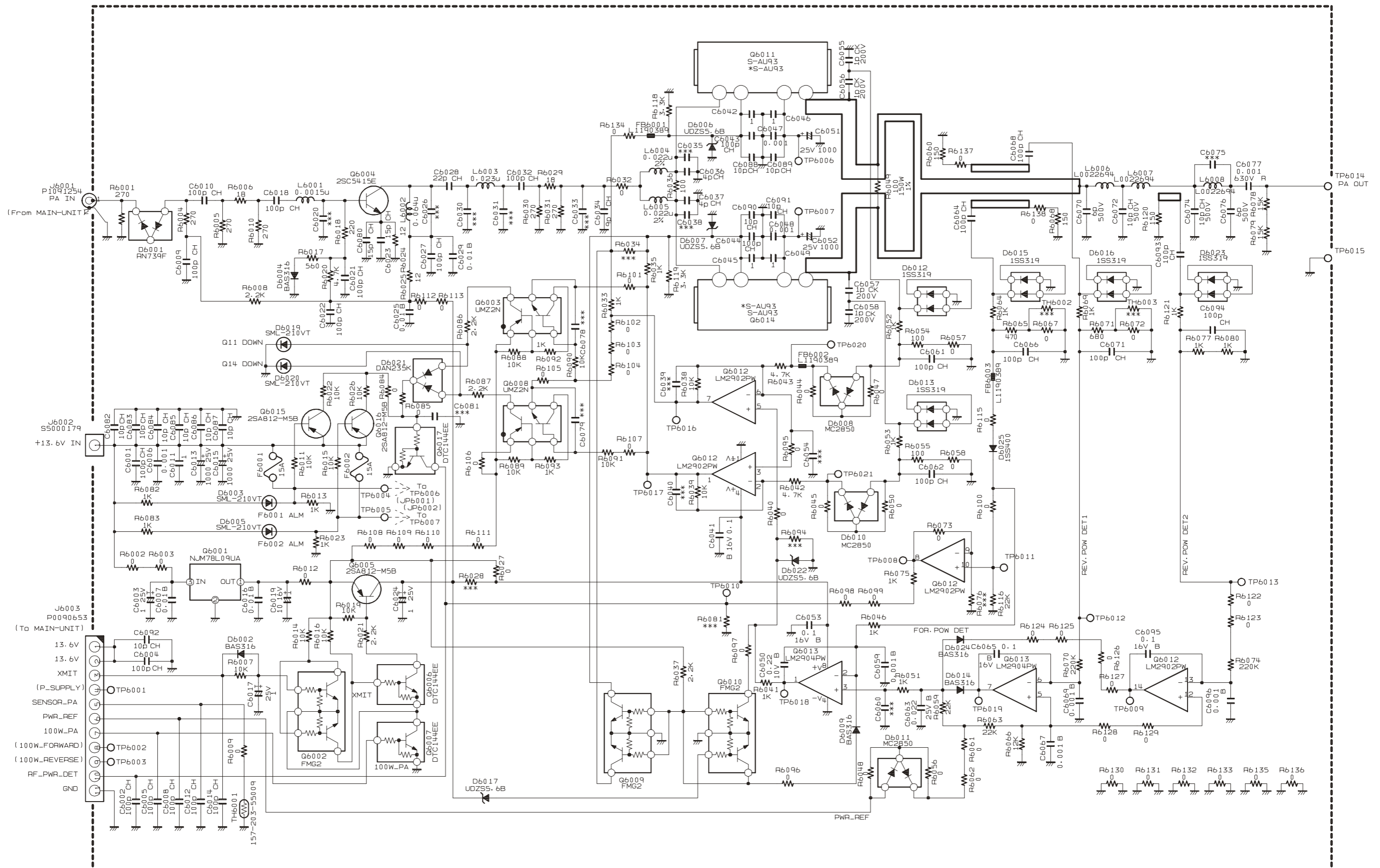

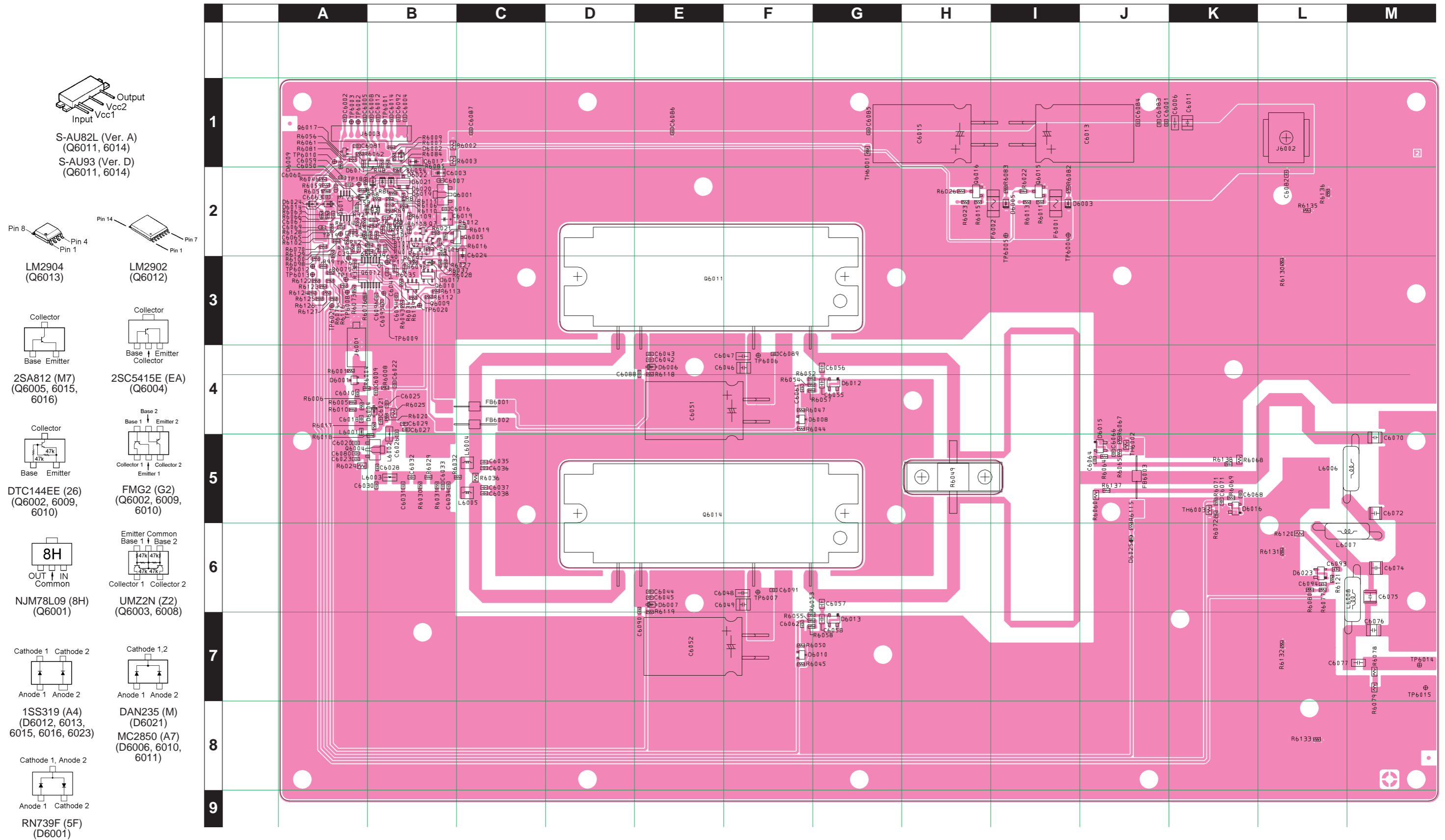

100W PA Unit (Option: Version D)

Note

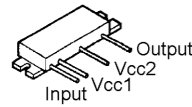

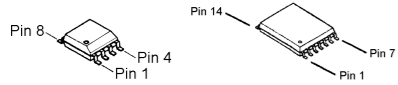

- 

S-AU82L (Ver. A)
(Q6011, 6014)
S-AU93 (Ver. D)
(Q6011, 6014)
- 

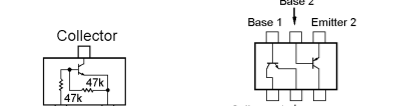
LM2904 (Q6013) LM2902 (Q6012)
- 

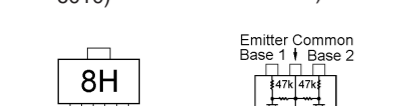
2SA812 (M7) (Q6005, 6015, 6016) 2SC5415E (EA) (Q6004)
- 

DTC144EE (26) (Q6002, 6009, 6010) FMG2 (G2) (Q6002, 6009, 6010)
- 

NJM78L09 (8H) (Q6001) UMZ2N (Z2) (Q6003, 6008)
- 

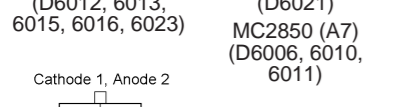
1SS319 (A4) (D6012, 6013, 6015, 6016, 6023) DAN235 (M) (D6021)
- 

RN739F (5F) (D6001)

100W PA Unit (Option: Version D)

Parts Layout (Side B)

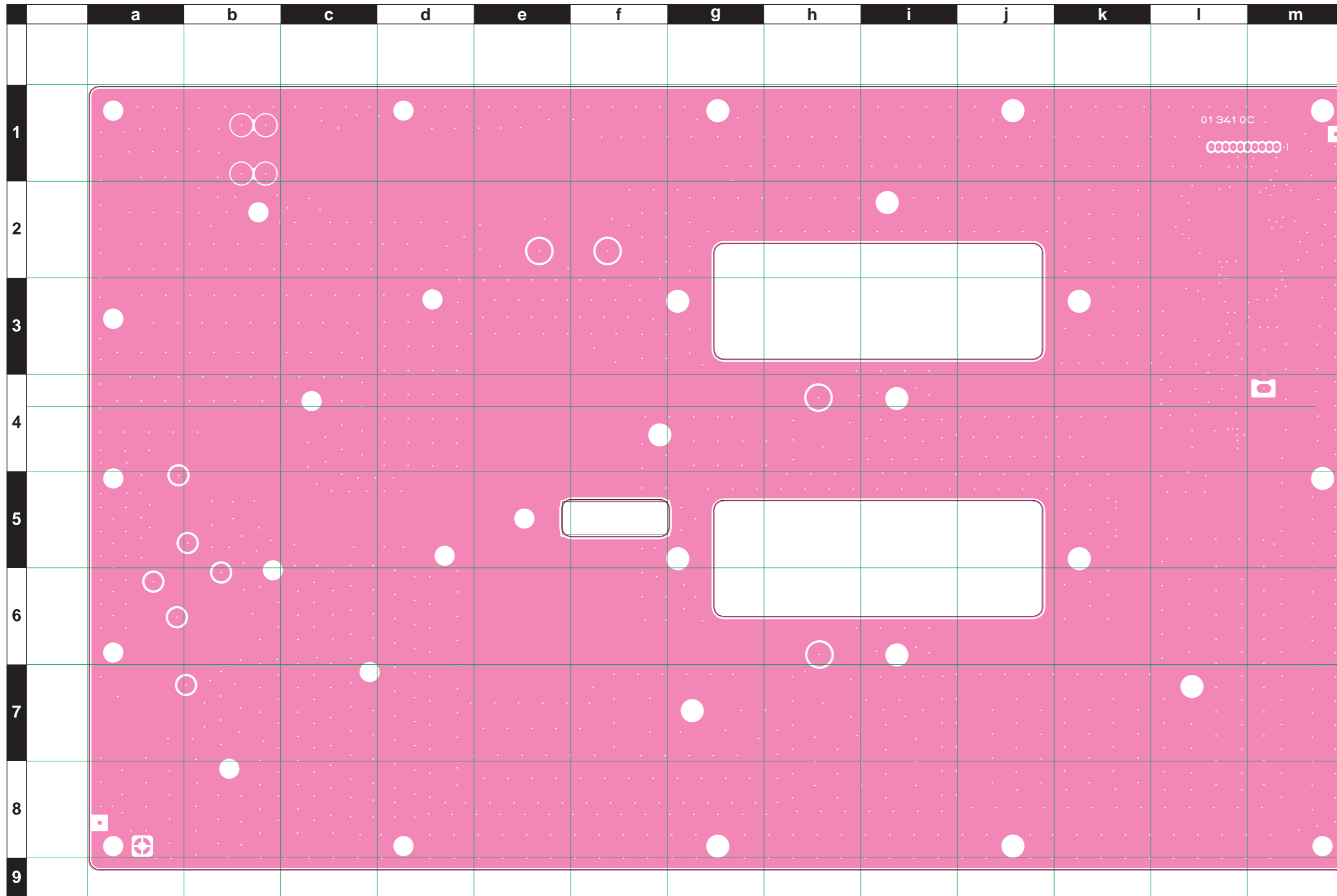

100W PA Unit (Option: Version D)

Parts List

REF	DESCRIPTION	VALUE	V/W	TOL.	MFR'S DESIG	VXSTD P/N	VERS.	LOT	SIDE	LAY ADR
PCB with Components (w/o Q6011 & Q6014 PA Module)						CS1866001	VER. D			
C 6001	CHIP CAP.	100pF	50V	CH	GRM1882C1H101JA01D	K22174235		1-	A	J1
C 6002	CHIP CAP.	100pF	50V	CH	GRM1882C1H101JA01D	K22174235		1-	A	A1
C 6003	CHIP TA.CAP.	1uF	25V		TEESVA1E105M8R	K78140013		1-	A	B2
C 6004	CHIP CAP.	100pF	50V	CH	GRM1882C1H101JA01D	K22174235		1-	A	B1
C 6005	CHIP CAP.	100pF	50V	CH	GRM1882C1H101JA01D	K22174235		1-	A	A1
C 6006	CHIP CAP.	0.001uF	630V	R	GRM31BR32J102KY01L	K22281801		1-9	A	K1
C 6006	CHIP CAP.	0.001uF	630V	UJ	GRM31A7U2J102JW31D	K22281803		10-	A	K1
C 6007	CHIP CAP.	0.01uF	50V	B	GRM188B11H103KA01D	K22174823		1-	A	B2
C 6008	CHIP CAP.	100pF	50V	CH	GRM1882C1H101JA01D	K22174235		1-	A	B1
C 6009	CHIP CAP.	100pF	50V	CH	GRM1882C1H101JA01D	K22174235		1-	A	B5
C 6010	CHIP CAP.	100pF	50V	CH	GRM1882C1H101JA01D	K22174235		1-	A	A5
C 6011	CHIP CAP.	1uF	50V	B	GRM32RB11H105KA01L	K22175801		1-	A	K1
C 6012	CHIP CAP.	100pF	50V	CH	GRM1882C1H101JA01D	K22174235		1-	A	B1
C 6013	AL.ELECTRO.CAP.	1000uF	25V		RJ3-25V102MI5#	K40149041		1-	A	B1
C 6014	CHIP CAP.	100pF	50V	CH	GRM1882C1H101JA01D	K22174235		1-	A	I1
C 6015	AL.ELECTRO.CAP.	1000uF	25V		RJ3-25V102MI5#	K40149041		1-	A	H2
C 6016	CHIP CAP.	0.01uF	50V	B	GRM188B11H103KA01D	K22174823		1-	A	B2
C 6017	CHIP TA.CAP.	1uF	25V		TEESVA1E105M8R	K78140013		1-	A	B2
C 6018	CHIP CAP.	100pF	50V	CH	GRM1882C1H101JA01D	K22174235		1-	A	A5
C 6019	CHIP TA.CAP.	10uF	16V		TEESVB21C106M8R	K78120025		1-	A	B3
C 6021	CHIP CAP.	100pF	50V	CH	GRM1882C1H101JA01D	K22174235		1-	A	B5
C 6022	CHIP CAP.	100pF	50V	CH	GRM1882C1H101JA01D	K22174235		1-	A	B4
C 6023	CHIP CAP.	15pF	50V	CH	GRM1882C1H150JA01D	K22174215		1-	A	A5
C 6024	CHIP TA.CAP.	1uF	25V		TEESVA1E105M8R	K78140013		1-	A	C3
C 6025	CHIP CAP.	0.01uF	50V	B	GRM188B11H103KA01D	K22174823		1-	A	B5
C 6027	CHIP CAP.	100pF	50V	CH	GRM1882C1H101JA01D	K22174235		1-	A	B5
C 6028	CHIP CAP.	22pF	50V	CH	GRM1882C1H220JA01D	K22174219		1-	A	B5
C 6029	CHIP CAP.	0.01uF	50V	B	GRM188B11H103KA01D	K22174823		1-	A	B5
C 6032	CHIP CAP.	100pF	50V	CH	GRM1882C1H101JA01D	K22174235		1-	A	B5
C 6034	CHIP CAP.	9pF	50V	CH	GRM1882C1H9R0CZ01D	K22174247		1-	A	B6
C 6036	CHIP CAP.	4pF	50V	CH	GRM1882C1H4R0CZ01D	K22174205		1-	A	C5
C 6037	CHIP CAP.	4pF	50V	CH	GRM1882C1H4R0CZ01D	K22174205		1-	A	C6
C 6041	CHIP CAP.	0.1uF	16V	B	GRM188B11C104KA01D	K22124805		1-	A	B3
C 6042	CHIP CAP.	1uF	6.3V	B	GRM188B10J105KA01D	K22084801		1-	A	E4
C 6043	CHIP CAP.	100pF	50V	CH	GRM1882C1H101JA01D	K22174235		1-	A	E4
C 6044	CHIP CAP.	100pF	50V	CH	GRM1882C1H101JA01D	K22174235		1-	A	E7
C 6045	CHIP CAP.	1uF	6.3V	B	GRM188B10J105KA01D	K22084801		1-	A	E7
C 6046	CHIP CAP.	1uF	50V	B	GRM32RB11H105KA01L	K22175801		1-	A	F4
C 6047	CHIP CAP.	0.001uF	630V	R	GRM31BR32J102KY01L	K22281801		1-9	A	F4
C 6047	CHIP CAP.	0.001uF	630V	UJ	GRM31A7U2J102JW31D	K22281803		10-	A	F4
C 6048	CHIP CAP.	0.001uF	630V	R	GRM31BR32J102KY01L	K22281801		1-9	A	F7
C 6048	CHIP CAP.	0.001uF	630V	UJ	GRM31A7U2J102JW31D	K22281803		10-	A	F7
C 6049	CHIP CAP.	1uF	50V	B	GRM32RB11H105KA01L	K22175801		1-	A	F7
C 6050	CHIP CAP.	0.22uF	10V	B	GRM188B11A224KA01D	K22104801		1-	A	A2
C 6051	AL.ELECTRO.CAP.	1000uF	25V		RJ3-25V102MI5#	K40149041		1-	A	F5
C 6052	AL.ELECTRO.CAP.	1000uF	25V		RJ3-25V102MI5#	K40149041		1-	A	F7
C 6053	CHIP CAP.	0.1uF	16V	B	GRM188B11C104KA01D	K22124805		1-	A	A2
C 6055	CHIP CAP.	1pF	200V	CK	GRM2194C2D1R0CY21D	K22230208		1-	A	G4
C 6056	CHIP CAP.	1pF	200V	CK	GRM2194C2D1R0CY21D	K22230208		1-	A	G4
C 6057	CHIP CAP.	1pF	200V	CK	GRM2194C2D1R0CY21D	K22230208		1-	A	G7
C 6058	CHIP CAP.	1pF	200V	CK	GRM2194C2D1R0CY21D	K22230208		1-	A	G7
C 6059	CHIP CAP.	0.001uF	50V	B	GRM188B11H102KA01D	K22174821		1-	A	A2
C 6061	CHIP CAP.	100pF	50V	CH	GRM1882C1H101JA01D	K22174235		1-	A	F4
C 6062	CHIP CAP.	100pF	50V	CH	GRM1882C1H101JA01D	K22174235		1-	A	F7
C 6063	CHIP CAP.	0.022uF	25V	B	GRM39B223K25PT	K22144807		1-6	A	A2
C 6063	CHIP CAP.	0.022uF	50V	B	GRM188B11H223KA01D	K22174839		7-	A	A2
C 6064	CHIP CAP.	100pF	50V	CH	GRM1882C1H101JA01D	K22174235		1-	A	J5
C 6065	CHIP CAP.	0.1uF	16V	B	GRM188B11C104KA01D	K22124805		1-	A	A3
C 6066	CHIP CAP.	100pF	50V	CH	GRM1882C1H101JA01D	K22174235		1-	A	J5
C 6067	CHIP CAP.	0.001uF	50V	B	GRM188B11H102KA01D	K22174821		1-	A	A3
C 6068	CHIP CAP.	100pF	50V	CH	GRM1882C1H101JA01D	K22174235		1-	A	K6
C 6069	CHIP CAP.	0.001uF	50V	B	GRM188B11H102KA01D	K22174821		1-	A	A3
C 6070	FILM CAP.	6pF	500V		UC232H0060D-T	K33279045		1-	A	M5
C 6071	CHIP CAP.	100pF	50V	CH	GRM1882C1H101JA01D	K22174235		1-	A	K6
C 6072	CHIP CAP.	10pF	500V	CH	ERE22X6C2H100JD01L	K22273217		1-	A	M6
C 6074	CHIP CAP.	10pF	500V	CH	ERE22X6C2H100JD01L	K22273217		1-	A	M6
C 6076	FILM CAP.	6pF	500V		UC232H0060D-T	K33279045		1-	A	M7
C 6077	CHIP CAP.	0.001uF	630V	R	GRM31BR32J102KY01L	K22281801		1-9	A	M8
C 6077	CHIP CAP.	0.001uF	630V	UJ	GRM31A7U2J102JW31D	K22281803		10-	A	M8
C 6080	CHIP CAP.	15pF	50V	CH	GRM1882C1H150JA01D	K22174215		1-	A	A5
C 6082	CHIP CAP.	10pF	50V	CH	GRM1882C1H100JA01D	K22174211		1-	A	L2
C 6083	CHIP CAP.	10pF	50V	CH	GRM1882C1H100JA01D	K22174211		1-	A	J1

100W PA Unit (Option: Version D)

Parts List

REF	DESCRIPTION	VALUE	V/W	TOL.	MFR'S DESIG	VXSTD P/N	VERS.	LOT	SIDE	LAY ADR
C 6084	CHIP CAP.	10pF	50V	CH	GRM1882C1H100JA01D	K22174211		1-	A	J1
C 6085	CHIP CAP.	10pF	50V	CH	GRM1882C1H100JA01D	K22174211		1-	A	G2
C 6086	CHIP CAP.	10pF	50V	CH	GRM1882C1H100JA01D	K22174211		1-	A	E2
C 6087	CHIP CAP.	10pF	50V	CH	GRM1882C1H100JA01D	K22174211		1-	A	C2
C 6088	CHIP CAP.	10pF	50V	CH	GRM1882C1H100JA01D	K22174211		1-	A	E4
C 6089	CHIP CAP.	10pF	50V	CH	GRM1882C1H100JA01D	K22174211		1-	A	F4
C 6090	CHIP CAP.	10pF	50V	CH	GRM1882C1H100JA01D	K22174211		1-	A	E7
C 6091	CHIP CAP.	10pF	50V	CH	GRM1882C1H100JA01D	K22174211		1-	A	F7
C 6092	CHIP CAP.	10pF	50V	CH	GRM1882C1H100JA01D	K22174211		1-	A	B1
C 6093	CHIP CAP.	100pF	50V	CH	GRM1882C1H101JA01D	K22174235		1-	A	L6
C 6094	CHIP CAP.	100pF	50V	CH	GRM1882C1H101JA01D	K22174235		1-	A	L7
C 6095	CHIP CAP.	0.1uF	16V	B	GRM188B11C104KA01D	K22124805		1-	A	B4
C 6096	CHIP CAP.	0.001uF	50V	B	GRM188B11H102KA01D	K22174821		1-	A	B3
D 6001	DIODE				RN739F T106	G2070626		1-	A	A4
D 6002	DIODE				BAS316	G2070716		1-	A	B2
D 6003	LED				SML-210VTT86	G2070768		1-	A	I2
D 6004	DIODE				BAS316	G2070716		1-	A	B5
D 6005	LED				SML-210VTT86	G2070768		1-	A	I2
D 6006	DIODE				UDZS TE-17 5.6B	G2070910		1-	A	E4
D 6007	DIODE				UDZS TE-17 5.6B	G2070910		1-	A	E7
D 6008	DIODE				MC2850-T111-1	G2070704		1-	A	F5
D 6009	DIODE				BAS316	G2070716		1-	A	A2
D 6010	DIODE				MC2850-T111-1	G2070704		1-	A	F7
D 6011	DIODE				MC2850-T111-1	G2070704		1-	A	B2
D 6012	DIODE				1SS319(TE85R.F)	G2070080		1-	A	G4
D 6013	DIODE				1SS319(TE85R.F)	G2070080		1-	A	G7
D 6014	DIODE				BAS316	G2070716		1-	A	A2
D 6015	DIODE				1SS319(TE85R.F)	G2070080		1-	A	J5
D 6016	DIODE				1SS319(TE85R.F)	G2070080		1-	A	K6
D 6017	DIODE				UDZS TE-17 5.6B	G2070910		1-	A	B3
D 6019	LED				SML-210VTT86	G2070768		1-	A	B2
D 6020	LED				SML-210VTT86	G2070768		1-	A	B2
D 6021	DIODE				DAN235K T97	G2070082		1-	A	B2
D 6022	DIODE				UDZS TE-17 5.6B	G2070910		1-	A	B2
D 6023	DIODE				1SS319(TE85R.F)	G2070080		1-	A	L7
D 6024	DIODE				BAS316	G2070716		1-	A	A2
D 6025	DIODE				1SS400 TE61	G2070634		1-	A	J6
F 6001	CHIP FUSE	15A			451 015.MR 15A	Q0000105		1-	A	I2
F 6002	CHIP FUSE	15A			451 015.MR 15A	Q0000105		1-	A	I2
FB6001	M.RFC				FBA03VA450AB-00	L1190389		1-		
FB6002	M.RFC				FBA03VA450AB-00	L1190389		1-		
FB6003	M.RFC				FBA03VA450AB-00	L1190389		1-		
J 6001	CONNECTOR				TMP-S01X-C1	P1091254		1-	A	A4
J 6002	TERMINAL				Y106	S5000179		1-	A	L2
J 6003	CONNECTOR				IL-Y-11P-S15T2-E	P0090653		1-	A	B2
JP6001	WIRE ASSY				RED 125 <7>/<7>	T9318109		1-		
JP6002	WIRE ASSY				RED 145 <7>/<7>	T9318176		1-		
L 6001	M.RFC	0.0015uH			HK1608 1N5S-T	L1690506		1-	A	A5
L 6002	CHIP COIL	0.064uH			LQW31HN64NJ03L	L1690258		1-	A	B5
L 6003	CHIP COIL	0.023uH			LQW31HN23NJ03L	L1690252		1-	A	B5
L 6004	CHIP COIL	0.022uH		2%	C2520C-22NG-RA	L1691286		1-	A	C5
L 6005	CHIP COIL	0.022uH		2%	C2520C-22NG-RA	L1691286		1-	A	C6
L 6006	COIL C1				1.0T6.0D1.6PEW R	L0022694		1-	A	M5
L 6007	COIL C1				1.0T6.0D1.6PEW R	L0022694		1-	A	M6
L 6008	COIL C1				1.0T6.0D1.6PEW R	L0022694		1-	A	M6
Q 6001	IC				NJM78L09UA-TE2	G1091305		1-	A	B2
Q 6002	TRANSISTOR				FMG2 T148	G3070015		1-	A	B3
Q 6003	TRANSISTOR				UMZ2N TR	G3070117		1-	A	B2
Q 6004	TRANSISTOR				2SC5415E-TD-E	G3354158E		1-	A	B5
Q 6005	TRANSISTOR				2SA812-T2B M5B	G3108127E		1-	A	B3
Q 6006	TRANSISTOR				DTC144EE TL	G3070075		1-	A	B3
Q 6007	TRANSISTOR				DTC144EE TL	G3070075		1-	A	B3
Q 6008	TRANSISTOR				UMZ2N TR	G3070117		1-	A	B3
Q 6009	TRANSISTOR				FMG2 T148	G3070015		1-	A	B3
Q 6010	TRANSISTOR				FMG2 T148	G3070015		1-	A	B3
Q 6011	IC				S-AU93	G1094203		1-7	A	D3
Q 6011	IC				S-AU93A(VX.Q)	G1094616		8-	A	D3
Q 6012	IC				LM2902PWR	G1094009		1-	A	B3
Q 6013	IC				LM2904PWR	G1094010		1-	A	A2
Q 6014	IC				S-AU93	G1094203		1-7	A	D6
Q 6014	IC				S-AU93A(VX.Q)	G1094616		8-	A	D6
Q 6015	TRANSISTOR				2SA812-T2B M5B	G3108127E		1-	A	I2
Q 6016	TRANSISTOR				2SA812-T2B M5B	G3108127E		1-	A	H2

100W PA Unit (Option: Version D)

Parts List

REF	DESCRIPTION	VALUE	V/W	TOL.	MFR'S DESIG	VXSTD P/N	VERS.	LOT	SIDE	LAY ADR
Q 6017	TRANSISTOR				DTC144EE TL	G3070075		1-	A	A2
R 6001	CHIP RES.	270	1/16W	5%	RMC1/16 271JATP	J24185271		1-	A	A4
R 6002	CHIP RES.	0	1/10W	5%	RMC1/10T 000J	J24205000		1-	A	B2
R 6003	CHIP RES.	0	1/10W	5%	RMC1/10T 000J	J24205000		1-	A	B2
R 6004	CHIP RES.	270	1/16W	5%	RMC1/16 271JATP	J24185271		1-	A	A4
R 6005	CHIP RES.	270	1/16W	5%	RMC1/16 271JATP	J24185271		1-	A	A5
R 6006	CHIP RES.	18	1/16W	5%	RMC1/16 180JATP	J24185180		1-	A	A5
R 6007	CHIP RES.	10k	1/16W	5%	RMC1/16 103JATP	J24185103		1-	A	B2
R 6008	CHIP RES.	2.2k	1/16W	5%	RMC1/16 222JATP	J24185222		1-	A	B4
R 6009	CHIP RES.	0	1/16W	5%	RMC1/16 000JATP	J24185000		1-	A	B2
R 6010	CHIP RES.	270	1/16W	5%	RMC1/16 271JATP	J24185271		1-	A	A5
R 6011	CHIP RES.	10k	1/16W	5%	RMC1/16 103JATP	J24185103		1-	A	I2
R 6012	CHIP RES.	0	1/16W	5%	RMC1/16 000JATP	J24185000		1-	A	C3
R 6013	CHIP RES.	1k	1/16W	5%	RMC1/16 102JATP	J24185102		1-	A	I2
R 6014	CHIP RES.	10k	1/16W	5%	RMC1/16 103JATP	J24185103		1-	A	B3
R 6015	CHIP RES.	10k	1/16W	5%	RMC1/16 103JATP	J24185103		1-	A	H2
R 6016	CHIP RES.	10k	1/16W	5%	RMC1/16 103JATP	J24185103		1-	A	B3
R 6017	CHIP RES.	560	1/16W	5%	RMC1/16 561JATP	J24185561		1-	A	B5
R 6018	CHIP RES.	220	1/16W	5%	RMC1/16 221JATP	J24185221		1-	A	B5
R 6019	CHIP RES.	10k	1/16W	5%	RMC1/16 103JATP	J24185103		1-	A	B3
R 6020	CHIP RES.	4.7k	1/16W	5%	RMC1/16 472JATP	J24185472		1-	A	B5
R 6021	CHIP RES.	2.2k	1/16W	5%	RMC1/16 222JATP	J24185222		1-	A	B3
R 6022	CHIP RES.	10k	1/16W	5%	RMC1/16 103JATP	J24185103		1-	A	I2
R 6023	CHIP RES.	1k	1/16W	5%	RMC1/16 102JATP	J24185102		1-	A	H2
R 6024	CHIP RES.	12	1/10W	5%	RMC1/10T 120J	J24205120		1-	A	A5
R 6025	CHIP RES.	12	1/10W	5%	RMC1/10T 120J	J24205120		1-	A	B5
R 6026	CHIP RES.	10k	1/16W	5%	RMC1/16 103JATP	J24185103		1-	A	H2
R 6027	CHIP RES.	0	1/16W	5%	RMC1/16 000JATP	J24185000		1-	A	B3
R 6029	CHIP RES.	18	1/16W	5%	RMC1/16 180JATP	J24185180		1-	A	B5
R 6030	CHIP RES.	270	1/16W	5%	RMC1/16 271JATP	J24185271		1-	A	B6
R 6031	CHIP RES.	270	1/16W	5%	RMC1/16 271JATP	J24185271		1-	A	B6
R 6032	CHIP RES.	0	1/16W	5%	RMC1/16 000JATP	J24185000		1-	A	B5
R 6033	CHIP RES.	1k	1/16W	5%	RMC1/16 102JATP	J24185102		1-	A	A3
R 6035	CHIP RES.	1k	1/16W	5%	RMC1/16 102JATP	J24185102		1-	A	B3
R 6036	CHIP RES.	100	1/10W	5%	RMC1/10T 101J	J24205101		1-	A	C5
R 6037	CHIP RES.	2.2k	1/16W	5%	RMC1/16 222JATP	J24185222		1-	A	B3
R 6038	CHIP RES.	10k	1/16W	5%	RMC1/16 103JATP	J24185103		1-	A	A3
R 6039	CHIP RES.	10k	1/16W	5%	RMC1/16 103JATP	J24185103		1-	A	B3
R 6040	CHIP RES.	0	1/16W	5%	RMC1/16 000JATP	J24185000		1-	A	A3
R 6041	CHIP RES.	1k	1/16W	5%	RMC1/16 102JATP	J24185102		1-	A	A2
R 6042	CHIP RES.	4.7k	1/16W	5%	RMC1/16 472JATP	J24185472		1-	A	B3
R 6043	CHIP RES.	4.7k	1/16W	5%	RMC1/16 472JATP	J24185472		1-	A	B4
R 6044	CHIP RES.	0	1/16W	5%	RMC1/16 000JATP	J24185000		1-	A	F5
R 6045	CHIP RES.	0	1/16W	5%	RMC1/16 000JATP	J24185000		1-	A	F8
R 6046	CHIP RES.	1k	1/16W	5%	RMC1/16 102JATP	J24185102		1-	A	A2
R 6047	CHIP RES.	0	1/16W	5%	RMC1/16 000JATP	J24185000		1-	A	F5
R 6048	CHIP RES.	0	1/16W	5%	RMC1/16 000JATP	J24185000		1-	A	B2
R 6049	METAL FILM RES.	100	150W	1%	RFRF150C100F	J22529001		1-	A	H5
R 6050	CHIP RES.	0	1/16W	5%	RMC1/16 000JATP	J24185000		1-	A	F7
R 6051	CHIP RES.	1k	1/16W	5%	RMC1/16 102JATP	J24185102		1-	A	A2
R 6052	CHIP RES.	1k	1/16W	5%	RMC1/16 102JATP	J24185102		1-	A	F4
R 6053	CHIP RES.	1k	1/16W	5%	RMC1/16 102JATP	J24185102		1-	A	F7
R 6054	CHIP RES.	100	1/16W	5%	RMC1/16 101JATP	J24185101		1-	A	F4
R 6055	CHIP RES.	100	1/16W	5%	RMC1/16 101JATP	J24185101		1-	A	F7
R 6056	CHIP RES.	0	1/16W	5%	RMC1/16 000JATP	J24185000		1-	A	A2
R 6057	CHIP RES.	0	1/16W	5%	RMC1/16 000JATP	J24185000		1-	A	F4
R 6058	CHIP RES.	0	1/16W	5%	RMC1/16 000JATP	J24185000		1-	A	F7
R 6059	CHIP RES.	22k	1/16W	5%	RMC1/16 223JATP	J24185223		1-	A	A2
R 6060	CHIP RES.	150	1/10W	5%	RMC1/10T 151J	J24205151		1-	A	J6
R 6061	CHIP RES.	0	1/16W	5%	RMC1/16 000JATP	J24185000		1-	A	A2
R 6062	CHIP RES.	0	1/16W	5%	RMC1/16 000JATP	J24185000		1-	A	A2
R 6063	CHIP RES.	22k	1/16W	5%	RMC1/16 223JATP	J24185223		1-	A	A3
R 6064	CHIP RES.	1k	1/16W	5%	RMC1/16 102JATP	J24185102		1-	A	J5
R 6065	CHIP RES.	470	1/16W	5%	RMC1/16 471JATP	J24185471		1-	A	J5
R 6066	CHIP RES.	12k	1/16W	5%	RMC1/16 123JATP	J24185123		1-	A	A3
R 6067	CHIP RES.	0	1/16W	5%	RMC1/16 000JATP	J24185000		1-	A	J5
R 6068	CHIP RES.	150	1/10W	5%	RMC1/10T 151J	J24205151		1-	A	K5
R 6069	CHIP RES.	1k	1/16W	5%	RMC1/16 102JATP	J24185102		1-	A	K6
R 6070	CHIP RES.	220k	1/16W	5%	RMC1/16 224JATP	J24185224		1-	A	A3
R 6071	CHIP RES.	680	1/16W	5%	RMC1/16 681JATP	J24185681		1-	A	K6
R 6072	CHIP RES.	0	1/16W	5%	RMC1/16 000JATP	J24185000		1-	A	K6
R 6073	CHIP RES.	0	1/16W	5%	RMC1/16 000JATP	J24185000		1-	A	A3
R 6074	CHIP RES.	220k	1/16W	5%	RMC1/16 224JATP	J24185224		1-	A	A3

100W PA Unit (Option: Version D)

Parts List

REF	DESCRIPTION	VALUE	V/W	TOL.	MFR'S DESIG	VXSTD P/N	VERS.	LOT	SIDE	LAY ADR
R 6075	CHIP RES.	1k	1/16W	5%	RMC1/16 102JATP	J24185102		1-	A	A3
R 6077	CHIP RES.	1k	1/16W	5%	RMC1/16 102JATP	J24185102		1-	A	L7
R 6078	CHIP RES.	15k	1/10W	5%	RMC1/10T 153J	J24205153		1-	A	M8
R 6079	CHIP RES.	15k	1/10W	5%	RMC1/10T 153J	J24205153		1-	A	M8
R 6080	CHIP RES.	1k	1/16W	5%	RMC1/16 102JATP	J24185102		1-	A	L7
R 6082	CHIP RES.	1k	1/16W	5%	RMC1/16 102JATP	J24185102		1-	A	I2
R 6083	CHIP RES.	1k	1/16W	5%	RMC1/16 102JATP	J24185102		1-	A	I2
R 6084	CHIP RES.	0	1/16W	5%	RMC1/16 000JATP	J24185000		1-	A	B2
R 6085	CHIP RES.	0	1/16W	5%	RMC1/16 000JATP	J24185000		1-	A	B2
R 6086	CHIP RES.	2.2k	1/16W	5%	RMC1/16 222JATP	J24185222		1-	A	B2
R 6087	CHIP RES.	2.2k	1/16W	5%	RMC1/16 222JATP	J24185222		1-	A	B2
R 6088	CHIP RES.	10k	1/16W	5%	RMC1/16 103JATP	J24185103		1-	A	B2
R 6089	CHIP RES.	10k	1/16W	5%	RMC1/16 103JATP	J24185103		1-	A	B2
R 6090	CHIP RES.	10k	1/16W	5%	RMC1/16 103JATP	J24185103		1-	A	A3
R 6091	CHIP RES.	10k	1/16W	5%	RMC1/16 103JATP	J24185103		1-	A	B3
R 6092	CHIP RES.	1k	1/16W	5%	RMC1/16 102JATP	J24185102		1-	A	A2
R 6093	CHIP RES.	1k	1/16W	5%	RMC1/16 102JATP	J24185102		1-	A	B3
R 6095	CHIP RES.	0	1/16W	5%	RMC1/16 000JATP	J24185000		1-	A	B3
R 6096	CHIP RES.	0	1/16W	5%	RMC1/16 000JATP	J24185000		1-	A	B3
R 6097	CHIP RES.	0	1/16W	5%	RMC1/16 000JATP	J24185000		1-	A	B3
R 6098	CHIP RES.	0	1/16W	5%	RMC1/16 000JATP	J24185000		1-	A	A3
R 6099	CHIP RES.	0	1/16W	5%	RMC1/16 000JATP	J24185000		1-	A	A3
R 6100	CHIP RES.	0	1/16W	5%	RMC1/16 000JATP	J24185000		1-	A	A3
R 6101	CHIP RES.	0	1/16W	5%	RMC1/16 000JATP	J24185000		1-	A	B3
R 6102	CHIP RES.	0	1/16W	5%	RMC1/16 000JATP	J24185000		1-	A	A3
R 6103	CHIP RES.	0	1/16W	5%	RMC1/16 000JATP	J24185000		1-	A	A3
R 6104	CHIP RES.	0	1/16W	5%	RMC1/16 000JATP	J24185000		1-	A	A3
R 6105	CHIP RES.	0	1/16W	5%	RMC1/16 000JATP	J24185000		1-	A	B3
R 6106	CHIP RES.	0	1/16W	5%	RMC1/16 000JATP	J24185000		1-	A	B2
R 6107	CHIP RES.	0	1/16W	5%	RMC1/16 000JATP	J24185000		1-	A	B3
R 6108	CHIP RES.	0	1/16W	5%	RMC1/16 000JATP	J24185000		1-	A	B3
R 6109	CHIP RES.	0	1/16W	5%	RMC1/16 000JATP	J24185000		1-	A	B3
R 6110	CHIP RES.	0	1/16W	5%	RMC1/16 000JATP	J24185000		1-	A	B2
R 6111	CHIP RES.	0	1/16W	5%	RMC1/16 000JATP	J24185000		1-	A	B2
R 6112	CHIP RES.	0	1/16W	5%	RMC1/16 000JATP	J24185000		1-	A	B3
R 6113	CHIP RES.	0	1/16W	5%	RMC1/16 000JATP	J24185000		1-	A	B3
R 6115	CHIP RES.	0	1/16W	5%	RMC1/16 000JATP	J24185000		1-	A	J6
R 6116	CHIP RES.	22k	1/16W	5%	RMC1/16 223JATP	J24185223		1-	A	A3
R 6118	CHIP RES.	3.3k	1/16W	5%	RMC1/16 332JATP	J24185332		1-	A	E4
R 6119	CHIP RES.	3.3k	1/16W	5%	RMC1/16 332JATP	J24185332		1-	A	E7
R 6120	CHIP RES.	150	1/10W	5%	RMC1/10T 151J	J24205151		1-	A	L6
R 6121	CHIP RES.	1k	1/16W	5%	RMC1/16 102JATP	J24185102		1-	A	L7
R 6122	CHIP RES.	0	1/16W	5%	RMC1/16 000JATP	J24185000		1-	A	A3
R 6123	CHIP RES.	0	1/16W	5%	RMC1/16 000JATP	J24185000		1-	A	A3
R 6124	CHIP RES.	0	1/16W	5%	RMC1/16 000JATP	J24185000		1-	A	A3
R 6125	CHIP RES.	0	1/16W	5%	RMC1/16 000JATP	J24185000		1-	A	A3
R 6126	CHIP RES.	0	1/16W	5%	RMC1/16 000JATP	J24185000		1-	A	A3
R 6127	CHIP RES.	0	1/16W	5%	RMC1/16 000JATP	J24185000		1-	A	A3
R 6128	CHIP RES.	0	1/16W	5%	RMC1/16 000JATP	J24185000		1-	A	A3
R 6129	CHIP RES.	0	1/16W	5%	RMC1/16 000JATP	J24185000		1-	A	A3
R 6130	CHIP RES.	0	1/16W	5%	RMC1/16 000JATP	J24185000		1-	A	L3
R 6131	CHIP RES.	0	1/16W	5%	RMC1/16 000JATP	J24185000		1-	A	L6
R 6132	CHIP RES.	0	1/16W	5%	RMC1/16 000JATP	J24185000		1-	A	L7
R 6133	CHIP RES.	0	1/16W	5%	RMC1/16 000JATP	J24185000		1-	A	L8
R 6134	CHIP RES.	0	1/16W	5%	RMC1/16 000JATP	J24185000		1-	A	B3
R 6135	CHIP RES.	0	1/16W	5%	RMC1/16 000JATP	J24185000		1-	A	L2
R 6136	CHIP RES.	0	1/16W	5%	RMC1/16 000JATP	J24185000		1-	A	L2
R 6137	CHIP RES.	0	1/16W	5%	RMC1/16 000JATP	J24185000		1-	A	J6
R 6138	CHIP RES.	0	1/16W	5%	RMC1/16 000JATP	J24185000		1-	A	K5
TH6001	THERMISTOR				157-203-55009TP	G9090045		1-	A	G2

RELAY Unit (Option)

Circuit Diagram

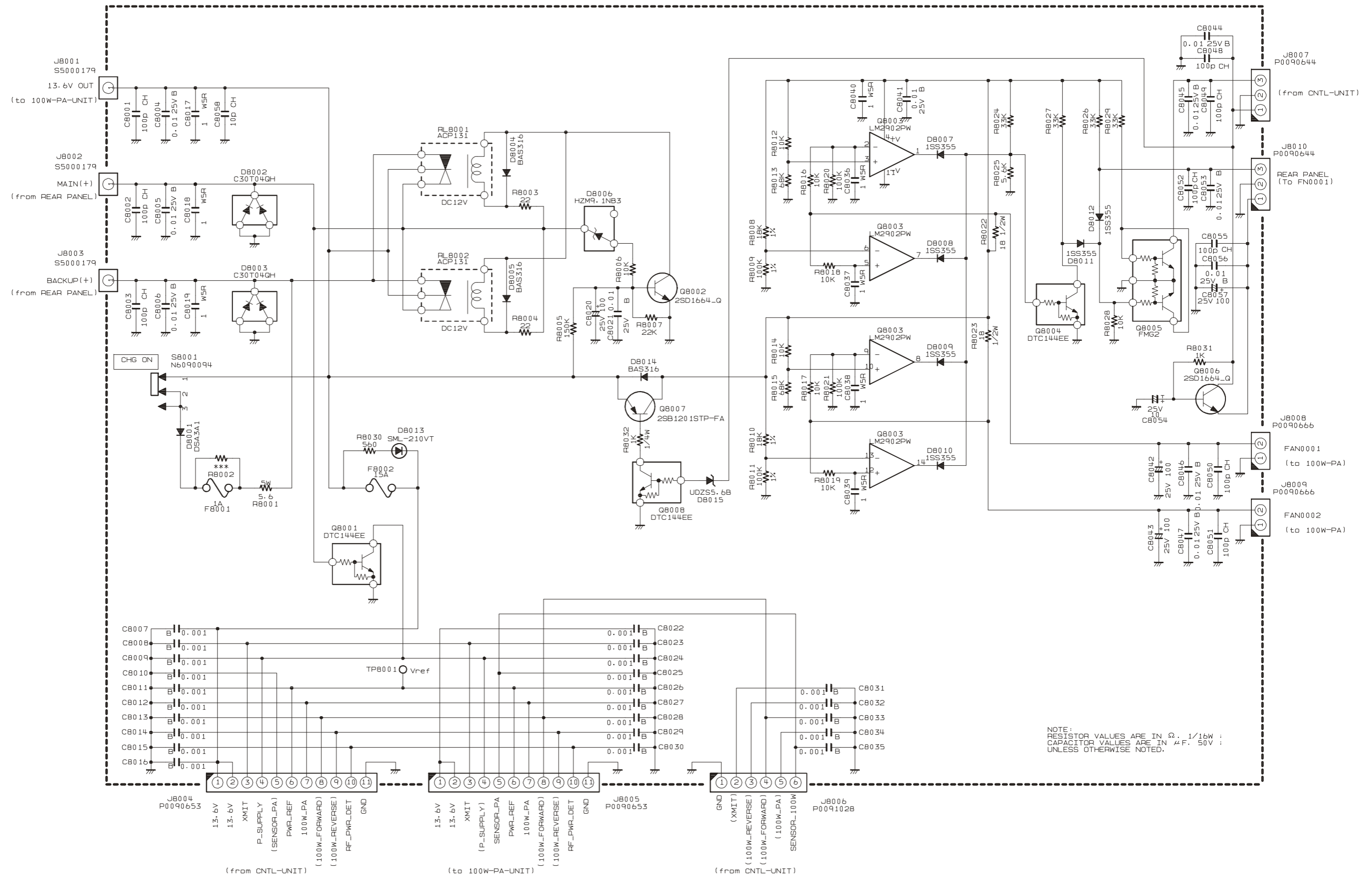

RELAY Unit (Option)

Parts Layout

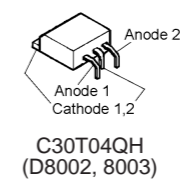
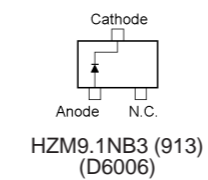
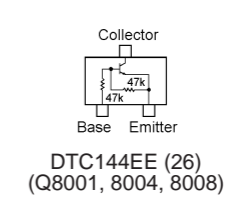
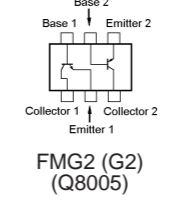
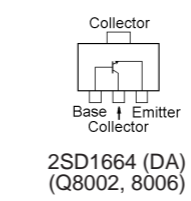
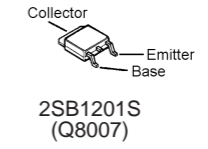
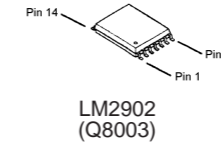
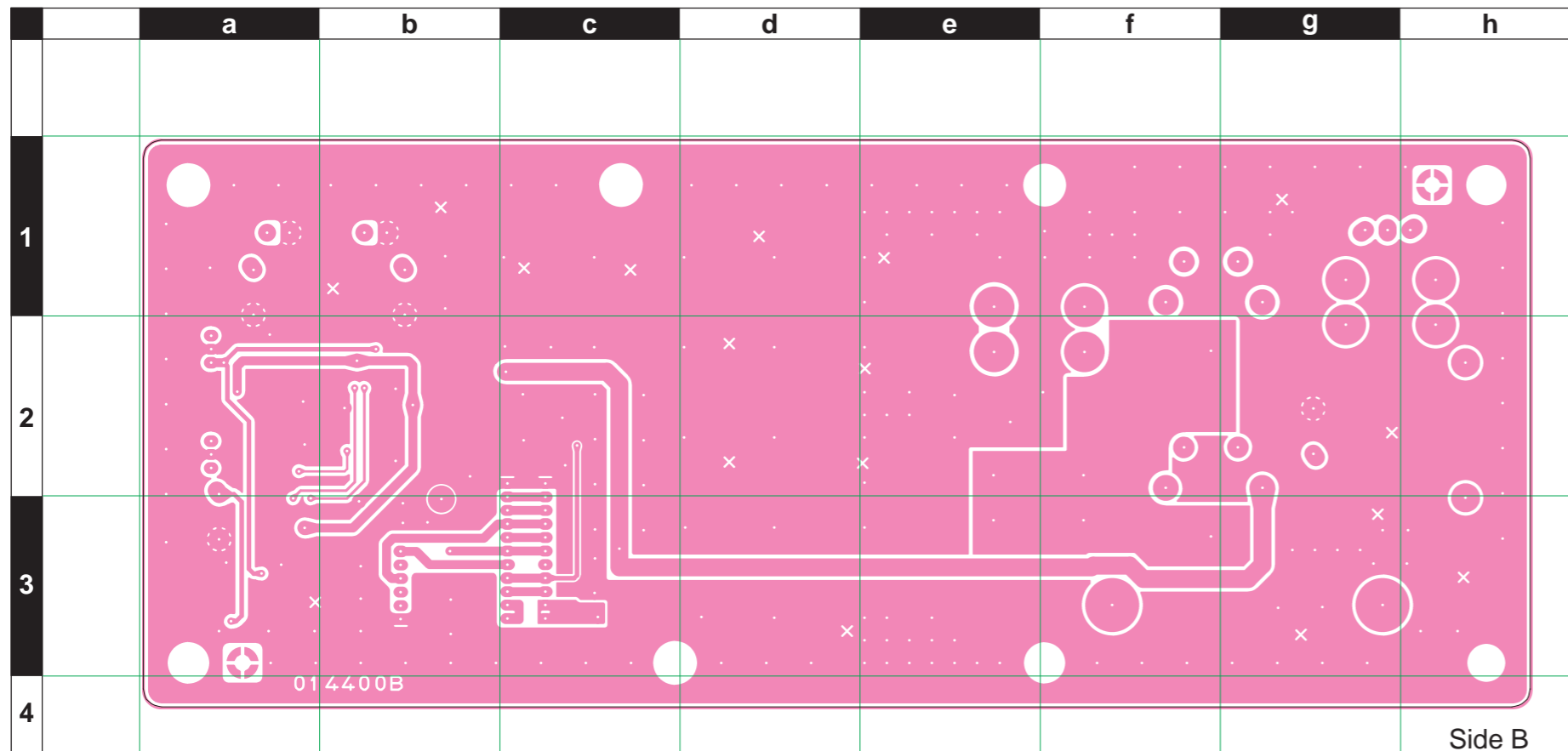
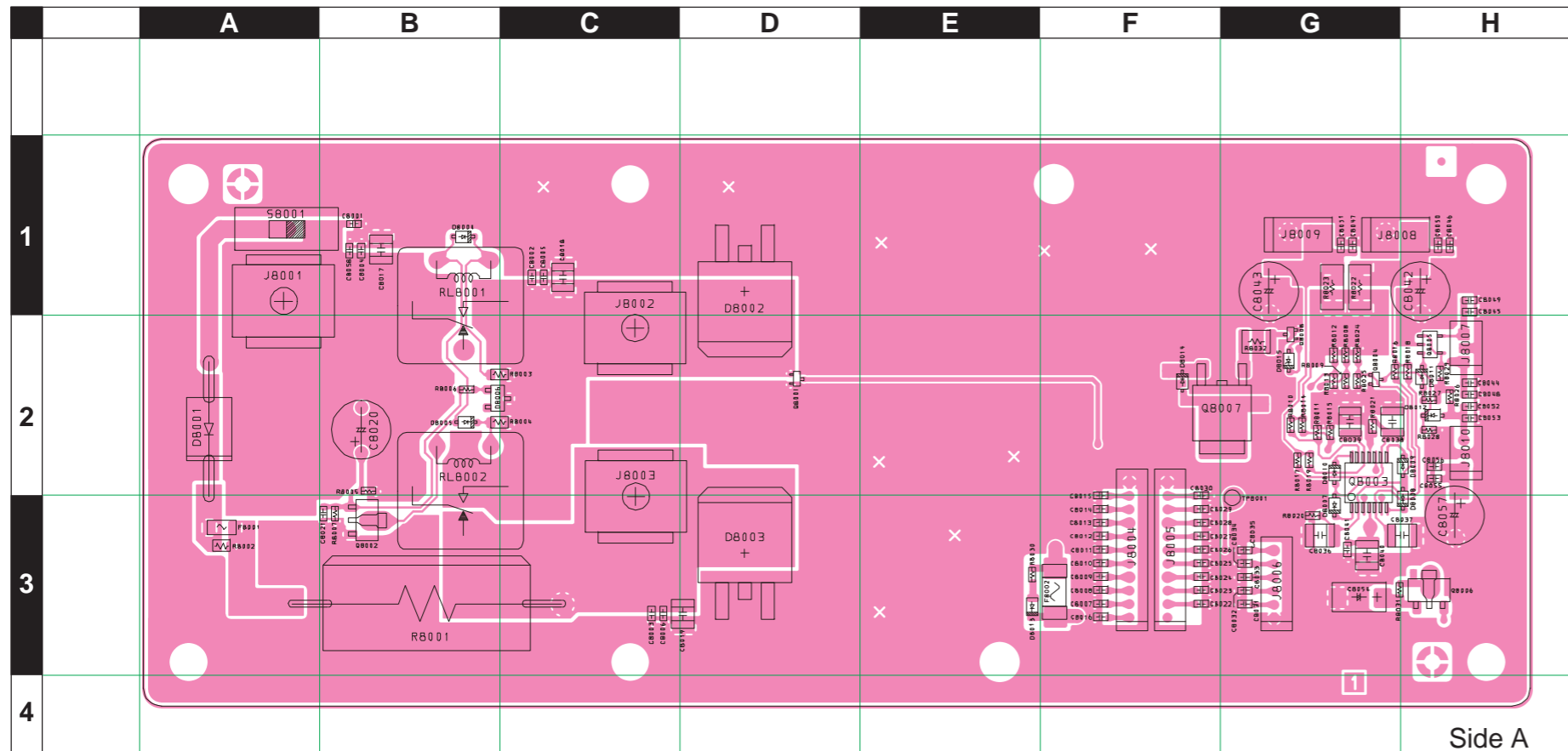

RELAY Unit (Option)

Parts List

REF	DESCRIPTION	VALUE	V/W	TOL.	MFR'S DESIG	VXSTD P/N	VERS.	LOT	SIDE	LAY ADR
PCB with Components						CS2382101				
C 8001	CHIP CAP.	100pF	50V	CH	GRM1882C1H101JA01D	K22174235		1-	A	B1
C 8002	CHIP CAP.	100pF	50V	CH	GRM1882C1H101JA01D	K22174235		1-	A	C2
C 8003	CHIP CAP.	100pF	50V	CH	GRM1882C1H101JA01D	K22174235		1-	A	C3
C 8004	CHIP CAP.	0.01uF	25V	B	GRM39B103M25PT	K22144802		1-6	A	B1
C 8004	CHIP CAP.	0.01uF	50V	B	GRM188B11H103KA01D	K22174823		7-	A	B1
C 8005	CHIP CAP.	0.01uF	25V	B	GRM39B103M25PT	K22144802		1-6	A	C2
C 8005	CHIP CAP.	0.01uF	50V	B	GRM188B11H103KA01D	K22174823		7-	A	C2
C 8006	CHIP CAP.	0.01uF	25V	B	GRM39B103M25PT	K22144802		1-6	A	C3
C 8006	CHIP CAP.	0.01uF	50V	B	GRM188B11H103KA01D	K22174823		7-	A	C3
C 8007	CHIP CAP.	0.001uF	50V	B	GRM188B11H102KA01D	K22174809		1-	A	F3
C 8008	CHIP CAP.	0.001uF	50V	B	GRM188B11H102KA01D	K22174809		1-	A	F3
C 8009	CHIP CAP.	0.001uF	50V	B	GRM188B11H102KA01D	K22174809		1-	A	F3
C 8010	CHIP CAP.	0.001uF	50V	B	GRM188B11H102KA01D	K22174809		1-	A	F3
C 8011	CHIP CAP.	0.001uF	50V	B	GRM188B11H102KA01D	K22174809		1-	A	F3
C 8012	CHIP CAP.	0.001uF	50V	B	GRM188B11H102KA01D	K22174809		1-	A	F3
C 8013	CHIP CAP.	0.001uF	50V	B	GRM188B11H102KA01D	K22174809		1-	A	F3
C 8014	CHIP CAP.	0.001uF	50V	B	GRM188B11H102KA01D	K22174809		1-	A	F3
C 8015	CHIP CAP.	0.001uF	50V	B	GRM188B11H102KA01D	K22174809		1-	A	F3
C 8016	CHIP CAP.	0.001uF	50V	B	GRM188B11H102KA01D	K22174809		1-	A	F3
C 8017	CHIP CAP.	1uF	50V	B	GRM32RB11H105KA01L	K22175801		1-	A	B1
C 8018	CHIP CAP.	1uF	50V	B	GRM32RB11H105KA01L	K22175801		1-	A	C2
C 8019	CHIP CAP.	1uF	50V	B	GRM32RB11H105KA01L	K22175801		1-	A	C3
C 8020	AL.ELECTRO.CAP.	100uF	25V		RJ3-25V101MF3#-T2	K46140010		1-	A	B2
C 8021	CHIP CAP.	0.01uF	25V	B	GRM39B103M25PT	K22144802		1-6	A	B3
C 8021	CHIP CAP.	0.01uF	50V	B	GRM188B11H103KA01D	K22174823		7-	A	B3
C 8022	CHIP CAP.	0.001uF	50V	B	GRM188B11H102KA01D	K22174809		1-	A	F3
C 8023	CHIP CAP.	0.001uF	50V	B	GRM188B11H102KA01D	K22174809		1-	A	F3
C 8024	CHIP CAP.	0.001uF	50V	B	GRM188B11H102KA01D	K22174809		1-	A	F3
C 8025	CHIP CAP.	0.001uF	50V	B	GRM188B11H102KA01D	K22174809		1-	A	F3
C 8026	CHIP CAP.	0.001uF	50V	B	GRM188B11H102KA01D	K22174809		1-	A	F3
C 8027	CHIP CAP.	0.001uF	50V	B	GRM188B11H102KA01D	K22174809		1-	A	F3
C 8028	CHIP CAP.	0.001uF	50V	B	GRM188B11H102KA01D	K22174809		1-	A	F3
C 8029	CHIP CAP.	0.001uF	50V	B	GRM188B11H102KA01D	K22174809		1-	A	F3
C 8030	CHIP CAP.	0.001uF	50V	B	GRM188B11H102KA01D	K22174809		1-	A	F3
C 8031	CHIP CAP.	0.001uF	50V	B	GRM188B11H102KA01D	K22174809		1-	A	G3
C 8032	CHIP CAP.	0.001uF	50V	B	GRM188B11H102KA01D	K22174809		1-	A	G3
C 8033	CHIP CAP.	0.001uF	50V	B	GRM188B11H102KA01D	K22174809		1-	A	G3
C 8034	CHIP CAP.	0.001uF	50V	B	GRM188B11H102KA01D	K22174809		1-	A	G3
C 8035	CHIP CAP.	0.001uF	50V	B	GRM188B11H102KA01D	K22174809		1-	A	G3
C 8036	CHIP CAP.	1uF	50V	B	GRM32RB11H105KA01L	K22175801		1-	A	G3
C 8037	CHIP CAP.	1uF	50V	B	GRM32RB11H105KA01L	K22175801		1-	A	G3
C 8038	CHIP CAP.	1uF	50V	B	GRM32RB11H105KA01L	K22175801		1-	A	G2
C 8039	CHIP CAP.	1uF	50V	B	GRM32RB11H105KA01L	K22175801		1-	A	G1
C 8040	CHIP CAP.	1uF	50V	B	GRM32RB11H105KA01L	K22175801		1-	A	G3
C 8041	CHIP CAP.	0.01uF	25V	B	GRM39B103M25PT	K22144802		1-6	A	G3
C 8041	CHIP CAP.	0.01uF	50V	B	GRM188B11H103KA01D	K22174823		7-	A	G3
C 8042	AL.ELECTRO.CAP.	100uF	25V		RJ3-25V101MF3#-T2	K46140010		1-	A	H1
C 8043	AL.ELECTRO.CAP.	100uF	25V		RJ3-25V101MF3#-T2	K46140010		1-	A	G1
C 8044	CHIP CAP.	0.01uF	25V	B	GRM39B103M25PT	K22144802		1-6	A	H2
C 8044	CHIP CAP.	0.01uF	50V	B	GRM188B11H103KA01D	K22174823		7-	A	H2
C 8045	CHIP CAP.	0.01uF	25V	B	GRM39B103M25PT	K22144802		1-6	A	H2
C 8045	CHIP CAP.	0.01uF	50V	B	GRM188B11H103KA01D	K22174823		7-	A	H2
C 8046	CHIP CAP.	0.01uF	25V	B	GRM39B103M25PT	K22144802		1-6	A	H1
C 8046	CHIP CAP.	0.01uF	50V	B	GRM188B11H103KA01D	K22174823		7-	A	H1
C 8047	CHIP CAP.	0.01uF	25V	B	GRM39B103M25PT	K22144802		1-6	A	G1
C 8047	CHIP CAP.	0.01uF	50V	B	GRM188B11H103KA01D	K22174823		7-	A	G1
C 8048	CHIP CAP.	100pF	50V	CH	GRM1882C1H101JA01D	K22174235		1-	A	H2
C 8049	CHIP CAP.	100pF	50V	CH	GRM1882C1H101JA01D	K22174235		1-	A	H2
C 8050	CHIP CAP.	100pF	50V	CH	GRM1882C1H101JA01D	K22174235		1-	A	H1
C 8051	CHIP CAP.	100pF	50V	CH	GRM1882C1H101JA01D	K22174235		1-	A	G1
C 8052	CHIP CAP.	100pF	50V	CH	GRM1882C1H101JA01D	K22174235		1-	A	H2
C 8053	CHIP CAP.	0.01uF	25V	B	GRM39B103M25PT	K22144802		1-6	A	H2
C 8053	CHIP CAP.	0.01uF	50V	B	GRM188B11H103KA01D	K22174823		7-	A	H2
C 8054	CHIP TA.CAP.	10uF	25V		TEESVC1E106M12R	K78140021		1-	A	G3
C 8055	CHIP CAP.	100pF	50V	CH	GRM1882C1H101JA01D	K22174235		1-	A	H3
C 8056	CHIP CAP.	0.01uF	25V	B	GRM39B103M25PT	K22144802		1-6	A	H3
C 8056	CHIP CAP.	0.01uF	50V	B	GRM188B11H103KA01D	K22174823		7-	A	H3
C 8057	AL.ELECTRO.CAP.	100uF	25V		RJ3-25V101MF3#-T2	K46140010		1-	A	H3
C 8058	CHIP CAP.	10pF	50V	CH	GRM1882C1H100JA01D	K22174211		1-	A	B1
D 8001	DIODE				DSA3A1	G2090445		1-	A	A3
D 8002	DIODE				C30T04QH-TE24L	G2070896		1-	A	D2
D 8003	DIODE				C30T04QH-TE24L	G2070896		1-	A	D3

RELAY Unit (Option)

Parts List

REF	DESCRIPTION	VALUE	V/W	TOL.	MFR'S DESIG	VXSTD P/N	VERS.	LOT	SIDE	LAY ADR
D 8004	DIODE				BAS316	G2070716		1-	A	B1
D 8005	DIODE				BAS316	G2070716		1-	A	B2
D 8006	DIODE				HZM9.1NB3 TR-E	G2070404		1-	A	B2
D 8007	DIODE				1SS355 TE-17	G2070470		1-	A	G3
D 8008	DIODE				1SS355 TE-17	G2070470		1-	A	G3
D 8009	DIODE				1SS355 TE-17	G2070470		1-	A	G3
D 8010	DIODE				1SS355 TE-17	G2070470		1-	A	G3
D 8011	DIODE				1SS355 TE-17	G2070470		1-	A	H2
D 8012	DIODE				1SS355 TE-17	G2070470		1-	A	H2
D 8013	LED				SML-210VTT86	G2070768		1-	A	E3
D 8014	DIODE				BAS316	G2070716		1-	A	F2
D 8015	DIODE				UDZS TE-17 5.6B	G2070910		1-	A	G2
F 8001	CHIP FUSE	1A			R429 001	Q0000089		1-9	A	A3
F 8001	CHIP FUSE	1A			0466001.NR	Q0000171		10-	A	A3
F 8002	CHIP FUSE	15A			451 015.MR 15A	Q0000105		1-	A	F3
J 8001	TERMINAL				Y106	S5000179		1-	A	A2
J 8002	TERMINAL				Y106	S5000179		1-	A	C2
J 8003	TERMINAL				Y106	S5000179		1-	A	C3
J 8004	CONNECTOR				IL-Y-11P-S15T2-E	P0090653		1-	A	F3
J 8005	CONNECTOR				IL-Y-11P-S15T2-E	P0090653		1-	A	F3
J 8006	CONNECTOR				IL-Y-6P-S15T2-EF	P0091028		1-	A	G3
J 8007	CONNECTOR				IL-Y-3P-S15T2-EF	P0090644		1-	A	H2
J 8008	CONNECTOR				B2B-EH(LF)(SN)	P0090666		1-	A	G1
J 8009	CONNECTOR				B2B-EH(LF)(SN)	P0090666		1-	A	G1
J 8010	CONNECTOR				IL-Y-3P-S15T2-EF	P0090644		1-	A	H3
Q 8001	TRANSISTOR				DTC144EE TL	G3070075		1-	A	D2
Q 8002	TRANSISTOR				2SD1664 T100 Q	G3416647Q		1-	A	B3
Q 8003	IC				LM2902PWR	G1094009		1-	A	G3
Q 8004	TRANSISTOR				DTC144EE TL	G3070075		1-	A	G2
Q 8005	TRANSISTOR				FMG2 T148	G3070015		1-	A	H2
Q 8006	TRANSISTOR				2SD1664 T100 Q	G3416647Q		1-	A	H3
Q 8007	TRANSISTOR				2SB1201S-TL	G3070195		1-	A	F2
Q 8008	TRANSISTOR				DTC144EE TL	G3070075		1-	A	G2
R 8001	CEMENT RES.	5.6	5W	10%	ERF-5AK5R6	J30376569		1-7	A	C3
R 8001	CEMENT RES.	5.6	5W	5%	BWR5C5R6J	J30375569		8-	A	C3
R 8003	CHIP RES.	22	1/10W	5%	RMC1/10T 220J	J24205220		1-	A	B2
R 8004	CHIP RES.	22	1/10W	5%	RMC1/10T 220J	J24205220		1-	A	B2
R 8005	CHIP RES.	150k	1/16W	5%	RMC1/16 154JATP	J24185154		1-	A	B3
R 8006	CHIP RES.	10k	1/16W	5%	RMC1/16 103JATP	J24185103		1-	A	B2
R 8007	CHIP RES.	22k	1/16W	5%	RMC1/16 223JATP	J24185223		1-	A	B3
R 8008	CHIP RES.	18k	1/16W	1%	RMC1/16 183FTP	J24183183		1-	A	G2
R 8009	CHIP RES.	100k	1/16W	1%	RMC1/16 104FTP	J24183104		1-	A	G2
R 8010	CHIP RES.	18k	1/16W	1%	RMC1/16 183FTP	J24183183		1-	A	G2
R 8011	CHIP RES.	100k	1/16W	1%	RMC1/16 104FTP	J24183104		1-	A	G2
R 8012	CHIP RES.	10k	1/16W	5%	RMC1/16 103JATP	J24185103		1-	A	G2
R 8013	CHIP RES.	68k	1/16W	5%	RMC1/16 683JATP	J24185683		1-	A	G2
R 8014	CHIP RES.	10k	1/16W	5%	RMC1/16 103JATP	J24185103		1-	A	G2
R 8015	CHIP RES.	68k	1/16W	5%	RMC1/16 683JATP	J24185683		1-	A	G2
R 8016	CHIP RES.	10k	1/16W	5%	RMC1/16 103JATP	J24185103		1-	A	G2
R 8017	CHIP RES.	10k	1/16W	5%	RMC1/16 103JATP	J24185103		1-	A	G3
R 8018	CHIP RES.	10k	1/16W	5%	RMC1/16 103JATP	J24185103		1-	A	H2
R 8019	CHIP RES.	10k	1/16W	5%	RMC1/16 103JATP	J24185103		1-	A	G3
R 8020	CHIP RES.	100k	1/16W	5%	RMC1/16 104JATP	J24185104		1-	A	G3
R 8021	CHIP RES.	100k	1/16W	5%	RMC1/16 104JATP	J24185104		1-	A	G2
R 8022	CHIP RES.	18	1/2W	5%	RMC1/2 180JTE	J24275180		1-	A	G2
R 8023	CHIP RES.	18	1/2W	5%	RMC1/2 180JTE	J24275180		1-	A	G2
R 8024	CHIP RES.	33k	1/16W	5%	RMC1/16 333JATP	J24185333		1-	A	G2
R 8025	CHIP RES.	5.6k	1/16W	5%	RMC1/16 562JATP	J24185562		1-	A	G2
R 8026	CHIP RES.	33k	1/16W	5%	RMC1/16 333JATP	J24185333		1-	A	H2
R 8027	CHIP RES.	33k	1/16W	5%	RMC1/16 333JATP	J24185333		1-	A	H2
R 8028	CHIP RES.	10k	1/16W	5%	RMC1/16 103JATP	J24185103		1-	A	H2
R 8029	CHIP RES.	33k	1/16W	5%	RMC1/16 333JATP	J24185333		1-	A	H2
R 8030	CHIP RES.	560	1/16W	5%	RMC1/16 561JATP	J24185561		1-	A	E3
R 8031	CHIP RES.	1k	1/16W	5%	RMC1/16 102JATP	J24185102		1-	A	G3
R 8032	CHIP RES.	1k	1/4W	5%	RMC1/4 102JATP	J24245102		1-	A	G2
RL8001	RELAY		DC12V		ACP131 DC12V	M1190152		1-	A	C2
RL8002	RELAY		DC12V		ACP131 DC12V	M1190152		1-	A	C3
S 8001	SLIDE SWITCH				SSSS912N-2A-OR	N6090094		1-	A	A1
TP8001	TERMINAL				TP-K IPS-1136	Q5000050		1-	A	G3



No portion of this manual may be reproduced without the permission of Vertex Standard LMR, Inc.

Vertex Standard is a trademark of Vertex Standard LMR, Inc. All other trademarks are the property of their respective owners.

©2015 Vertex Standard LMR, Inc.
All rights reserved.