

TPN1105A
and
TPN1106A

POWER SUPPLY/BATTERY CHARGER

BATTERY PROTECTION & ALARM

OPTION NO. C28 & C38

OPTION NO. C29

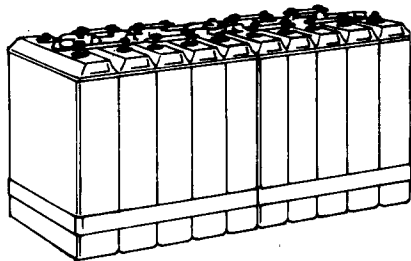

* EMERGENCY
BATTERY
BANK

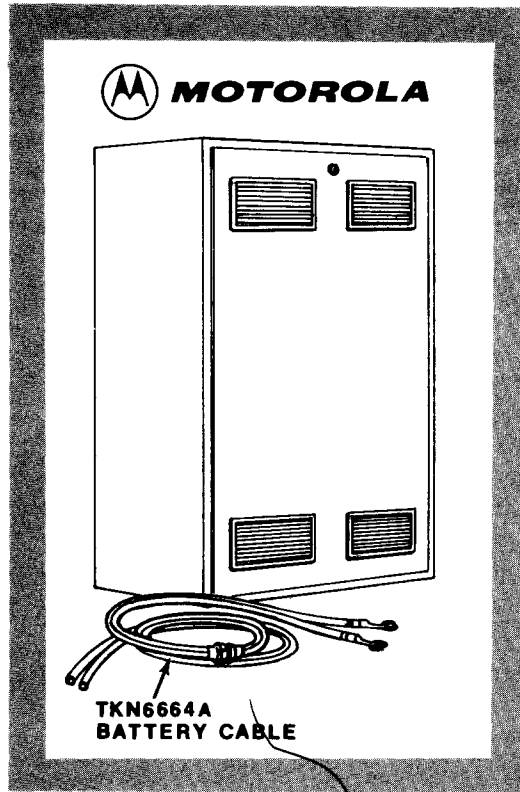

AEPS-12035-0

* AVAILABLE FROM MOTOROLA AS SEPARATE ITEM.

 **MOTOROLA INC.**
Communications Division

Copyright 1980 by Motorola, Inc.
Printed in U. S. A.

service publications
1301 E. Algonquin Road, Schaumburg, IL 60196

68P81104E92-E
7/15/80-UP

SPECIFICATIONS

POWER SUPPLY FEATURES

OPTION	C28	C38
POWER SUPPLY MODEL NO.	TPN1106A	TPN1105A
AC INPUT	121 V rms 60 Hz	121 or 242 V rms 50 or 60 Hz
EMERGENCY POWER DC INPUT	12 volt battery bank	
OUTPUT CURRENT LIMIT SET @	30 Amps \pm 1 Amp	
OUTPUT VOLTAGE	14.25 V	

BATTERY CHARGER FEATURES

DC OUTPUT FOR NICKEL-CADMIUM BATTERY	FLOAT	14.25 V \pm 0.1 V
	EQUALIZE	15.25 V \pm 0.2 V
DC OUTPUT FOR LEAD-ACID BATTERY	FLOAT	13.0 V \pm 0.1 V
	EQUALIZE	14.0 V \pm 0.2 V

BATTERY PROTECTION & ALARM

OPTION NO.	C29
EMERGENCY POWER ALARM	Audible alarm, interrupted tone, adjustable level
LOW BATTERY VOLTAGE ALARM OR BATTERY PROTECTION	Audible alarm changes to continuous tone, OR automatic battery disconnect when battery discharges to critical level.

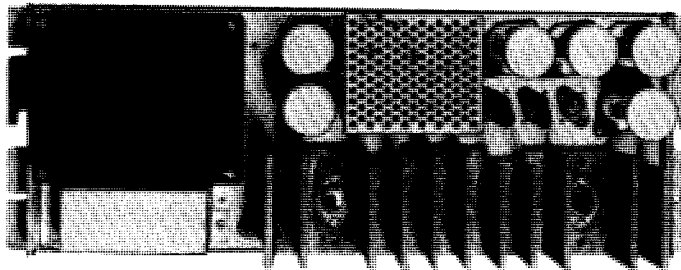

OPTION MODEL CHART

	OPTION		
	C28	C38	C29
POWER SUPPLY	TPN1106A	TPN1105A	*
CABLE KIT	TKN6664A	TKN6664A	
ALARM TONE GENERATOR BOARD			TLN5329A
RELAY MOUNTING			TLN5330A

*The C29 option is used in addition to the C28 or C38 Power Supply/Battery Charger option.

POWER SUPPLY/BATTERY CHARGER MODEL CHART

	POWER SUPPLY/BATTERY CHARGER	
	TPN1105A	TPN1106A
POWER SUPPLY FILTER	TFN6031A	TFN6031A
POWER SUPPLY CABLE	TKN6565A	TKN6565A
9.6 V REGULATOR BOARD	TLN4732A	TLN4732A
12 V REGULATOR BOARD	TLN5299A	TLN5299A
POWER SUPPLY CHASSIS	TLN5300A	TLN5298A

1. DESCRIPTION

The C28, C38, and C29 options are factory installed accessories that are available for all models of Motorola "Micor" base and repeater stations, either locally or remotely controlled.

● The C28 option permits the station to operate from 121 volt, 60 Hz ac power normally, but provides continued operation from 12-volt batteries (emergency power) if the ac power should fail. When ac power is restored, the power supply also operates as a battery charger to recharge the batteries.

● The C38 option is the same as the C28 option except that it operates from 121 or 242 volt, 50 or 60 Hz ac power, as well as 12 volt batteries.

● The C29 option is available only if the C28 or C38 power supply/battery charger option is also included. The C29 option is a Battery Protection & Alarm package that can be factory installed, to improve emergency power backup by providing an audible alarm whenever the station is operating on batteries. The battery protection and alarm option generates an audible alarm tone which "beeps" to indicate that the station is operating on emergency power. This tone burst, with a frequency of about 1400 Hz, is approximately 1/4 second long and repeats at 2-1/2 second intervals. On remote control stations, or repeater stations with wire line control, the alarm tone is injected into the audio line and is heard at the console (except when transmitting). On repeater stations, without wire line control, the tone is transmitted whenever the transmitter is keyed, so that anyone receiving signals from this station will know that it is operating on emergency power.

There are two ways of using the battery protection and alarm option. One way is to have the battery disconnect from the station load when the batteries have discharged to a certain level. This connection would protect the battery from damage due to excessive discharge, it also keeps the station from operating from voltages outside normal range.

The second method is to keep the batteries connected continuously during emergency use. When connected in this manner, the tone burst changes to a continuous tone of about 1400 Hz when the batteries have discharged below this defined level.

The power supply/battery chargers are of the high efficiency, variable duty cycle design. They

provide A+, audio A+, high current A+ all at 14.25 volts dc, and 9.6 volts dc to power any continuous or intermittent duty "Micor" "Compa-Station" radio. Current limiting, short circuit and over-voltage protection are also provided.

The batteries used as the emergency source can be of either the nickel-cadmium or lead-acid type. An automotive type battery is not recommended as an emergency dc supply.

A two position switch on the back plate of the power supply determines the charging rate of the batteries. In the FLOAT position, a voltage is supplied to the batteries, sufficient to maintain them in a fully charged state. The EQUALIZE position increases the charging voltage to restore the batteries after emergency use or where the condition of the battery dictates.

2. THEORY OF OPERATION

The explanation that follows pertains to the TPN1106A Power Supply. The only difference between this model and the TPN1105A Power Supply is the addition of E1002 spark gap, and different transformer wiring to accommodate the 121-242 volt, 50-60 Hz input.

"Switching" type regulation is incorporated in these power supplies. That is, an unregulated dc voltage is switched on and off to create dc pulses. These pulses are "averaged" into a lower dc voltage than was applied. The pulse width and the rate of pulse occurrence (and filtering) determines final output voltage. High current transistor switches are used to create these pulses and are controlled by power supply control circuitry that monitors output voltage and output current. Therefore, the power supply can be thought of as consisting of two "parts", switching and filtering, and switching control. The power supply schematic diagram must be referred to during the following discussion.

a. Switching and Filtering

(1) Input

AC power is applied to the power supply from the ac line plug across voltage dependent resistor (VDR), RV1001 and spark gap E1001. This transient suppression circuit prevents high voltage transients that may appear on the ac line from damaging the power supply or station. When the transient exceeds approximately 350 volts, spark gap E1001 conducts. At this voltage, the

VDR is a low resistance and the transient is effectively shunted from line to line. As the transient voltage decays, the VDR resistance increases to its former value, limiting the total current through the spark gap to a safe value. When the ac line voltage passes through zero the spark gap is extinguished and the protection circuitry is "reset" for another transient.

A full wave bridge rectifier consisting of diodes CR1001, CR1002, CR1003, and CR1004 provide the rectification that creates approximately 60 volts dc at input filter capacitors C1006 thru C1009. This is an unregulated source from which power is drawn in pulses to create the regulated output of the power supply.

(2) Crowbar SCR

Silicon controlled rectifier, SCR1001, shorts the 60 volts dc on the input filter capacitors to ground should power supply output attempt to rise above 18.0 volts. This causes fuse F1002 to blow which shuts down the power supply.

The gate (control lead) of the SCR is connected to a crowbar trigger circuit located on the power supply regulator circuit board. When a positive voltage is applied to the gate of SCR1001, it turns on which shorts the 60 volts to ground.

(3) Power Switch and Drivers

When power switches Q1001 and Q1002 are on, power is transferred from the unregulated 60 volt source to the power supply output filtering circuits.

Q1001 and Q1002 are turned on when a positive potential is routed from the variable width monostable on the 14.0 volt regulator circuit board to predriver, Q1005. When Q1005 turns on, a low is applied to switch drivers Q1003 and Q1004 which then also turn on. Now a high is applied to the bases of Q1002 and Q1001 which turn on. When the positive potential from the variable width monostable disappears, all these transistors turn off preventing dc input power from reaching the dc output filter stages. Therefore, the rate and duration of the pulses from the variable width monostable determine the amount of power delivered to the power supply output filtering stages.

(4) Output Filtering Stages

"Free wheeling" diodes, CR1008, CR1007 and choke input filter stage consisting of choke

L1001 and capacitor C1011 provide initial output filtering (or integration) of the switched dc pulses. When the power switches conduct, C1012 and C1013 charge positively. When the power switches stop conducting, CR1008 and CR1007 conduct and energy "stored" in L1001 is applied to the load which results in very high power supply efficiency.

Capacitor C1011 is a high frequency bypass capacitor that aids in eliminating high frequency components generated by power supply switching. Resistor R1011 is a "bleeder" resistor and provides a minimum load to the supply. Shunt resistor, R1013, is a current sensing resistor used in conjunction with the current limiter circuit described later. Capacitor C1018 reduces output impedance of the power supply at audio frequencies. The two parallel diodes in series with the power supply output, CR1005 and CR1012, are used to isolate the battery from the power supply.

High current A+ is available to the transmitter power amplifier from the high current filter. Lower current filtered A+ and A+ are available to power the reset of the station from the low current filter section. Regulated +9.6 V is available from the 9.6-volt regulator.

b. Switching Control

(1) Variable Width Monostable

The variable width monostable determines the duty cycle of the power supply by determining the length of time the power switch transistors are allowed to conduct. As ac line voltage or load changes occur, the monostable output pulse width is altered to compensate for resultant changes in the dc input to the power switches.

Four conditions govern operation of the variable width monostable.

First, 6.8 volts must be present from either the start or run 6.8 volt sources to permit monostable operation. Second, when the power supply is first turned on, positive going pulses are applied to the base of Q1028 from the 20 kHz astable to trigger the monostable for a period of time which is determined by capacitor C1052 and resistor R1066. Third, after the power supply output voltage increases, a forward bias voltage is fed to the base of control transistor Q1030. This voltage is derived from and is proportional to the output voltage and controls the pulse width. Fourth, current is ultimately supplied to the collector of emitter follower driver. Q1031,

through resistor R1070 and diode CR1039 once the power supply is running.

Before drive pulses are received from the 20 kHz astable, Q1028 is off and Q1032 is on. When a positive going pulse is received from the 20 kHz astable, Q1028 turns on and Q1032 turns off for a period of time determined by capacitor C1052, resistor R1066, and control transistor, Q1030. Control transistor Q1030 and its emitter resistor R1065 are in parallel with resistor R1066. The more Q1030 conducts, the lower its emitter to collector resistance becomes, thus lowering the RC time constant of C1052, R1066, and Q1030 which causes the monostable pulse width to decrease. Q1030 is driven by the voltage regulator and controls the duty cycle of the power switches. Therefore, the power supply output voltage stabilizes at a point determined by the setting of the OUTPUT VOLTAGE ADJUST control. Any tendency toward an increase in power supply output voltage is counteracted by decreasing the width of the monostable output pulse and any tendency toward a decrease in power supply output voltage is counteracted by increasing the width of the monostable output pulse. Pull-up transistor, Q1029 insures that capacitor C1052 is completely recharged by the time each succeeding pulse is received from the 20 kHz astable. Emitter follower transistor, Q1031, provides the drive to predriver transistor, Q1005, and isolates the effects of power switching from the monostable.

(2) 20 kHz Astable

The 20 kHz astable determines the rate at which the power switches turn on by controlling the rate at which pulses are delivered to the variable width monostable. Power switch conduction period is determined by the variable width monostable as described previously. The 20 kHz astable is basically a free running multivibrator that runs at a frequency of from 500 Hz to 20 kHz, depending on the "state" (start or run) of the power supply.

Three conditions govern operation of the 20 kHz astable. First, A+ must be applied through resistor R1058 from either the start or run 6.8 volt sources to permit astable operation. Second, when the power supply is in the start mode, the start sweep control causes the 20 kHz astable to start oscillating at 500 Hz and gradually rise to 20 kHz. Third, the load to the power supply must not present a short (less than .4 ohm) or the sweep control circuit will prevent the astable from sweeping up to 20 kHz. There is no power supply output while the 20 kHz astable

is not running and only a very limited output when it is running at 500 Hz.

During a power supply start attempt, +6.8 volts is supplied from the start 6.8 volt source for approximately 2-1/2 seconds. When the start attempt begins, the 20 kHz astable runs at 500 Hz since only capacitors C1047 and C1049 and resistors R1050 and R1054 determine the switching rate. As power supply output voltage increases, astable control transistor, Q1025, begins to conduct which increases the frequency of the astable. The more the astable control transistor is driven into conduction, the lower the astable RC time constant and the higher its frequency. When the astable control transistor is ultimately driven into saturation, the frequency of the astable is 20 kHz. After approximately one to two seconds from the beginning of the start attempt, the supply reaches its run state and +6.8 volts to the astable is supplied from the run 6.8 volt source. Pull-up transistors, Q1023 and Q1026, allow rapid recharge of capacitors C1047 and C1049 as the astable is switching.

(3) Start Sweep Control

The start sweep control prevents over-dissipation of the power switches during a normal start condition and when the supply is attempting to start into a short circuit. It also determines the maximum load into which the power supply will start. The start sweep control accomplishes this limiting action by holding the frequency of the 20 kHz astable to 500 Hz until the supply output voltage rises above a pre-determined level and by then gradually increasing the frequency to 20 kHz. Note that until normal output voltage is reached, the variable width monostable will produce its maximum pulse width (approximately 35 microseconds). This necessitates limiting the duty cycle of the power switches until the extreme load presented by uncharged output-filter capacitors or a short circuit is no longer present.

Comparator Q1036 establishes the output voltage at which the sweep from 500 Hz to 20 kHz will begin. Q1036 base voltage is controlled (via CR1043) by the supply output voltage and its emitter bias is derived from the input dc voltage. During the initial (500 Hz) period of a start attempt, the rising output voltage allows Q1036 to turn on. This turns on switch Q1035 via inverter, Q1037. When Q1035 conducts, C1048 charges through R1080 gradually turning on control transistor, Q1025, in the 20 kHz astable which "sweeps" the astable from 500 Hz to 20 kHz in approximately one second.

The time at which sweep occurs after the beginning of the start attempt varies with load. At light loads, sweep begins almost immediately. At maximum load, it may take up to two seconds to being to sweep. An excessive load will not allow the output voltage to rise high enough during the start attempt period to being the sweep.

(4) Start Clock Astable

The start clock astable regulates the times when the power supply will attempt to start after input power has been applied or when overload condition exists. This circuit controls the start 6.8 voltage which is applied to the 20 kHz astable, variable width monostable, and start sweep control.

Assume Q1014 and Q1016 to be cut off when A+ is applied. Capacitor C1039 charges positively via resistors R1031, R1030, R1036, and diode CR1018 (providing a slight delay). Q1014 conducts and the power supply "start" attempt begins. Q1014 is on and Q1017 is off for approximately 2-1/2 seconds. This turns on emitter follower, Q1018, and driver, Q1019, and finally start 6.8 volts source transistor, Q1020, for the same interval of time. When Q1020 is on, start 6.8 voltage is created. Emitter follower, Q1018, is used to isolate the astable clock from its load.

(5) Start and Run 6.8 Volt Source - Run Short Circuit Protection

The start 6.8 voltage source and a run 6.8 voltage source are used as control voltages for the 20 kHz astable and variable width monostable. As the names imply, start 6.8 volts is available only during a start attempt and run 6.8 volts is available only after the power supply is running. The start 6.8 voltage is derived from the input dc voltage and provides 6.8 volts before power supply output itself is capable of providing run 6.8 volts.

When a start attempt begins, the start clock astable causes the start 6.8 volts switch transistor, Q1020, to turn on. This applies a positive voltage through diode CR1023 to the 6.8 volt Zener diode, CR1025. This voltage will be present for only about 2-1/2 seconds, at which time the start clock astable will cut off Q1020. If the power supply does not start (such as when an overload exists) the start clock astable will, after 1-1/2 seconds, again initiate a 6.8 voltage. This recycling of start 6.8 voltage continues until the condition preventing start is corrected or until input power to the power supply is removed.

Run 6.8 voltage is derived from the output of the power supply and, when it is present, recycle of the start 6.8 voltage is inhibited.

When the power supply output voltage reaches approximately 10 volts, run 6.8 volts source transistor, Q1038, turns on which forward biases diode CR1024 and supplies current to Zener diode CR1025. Q1038 and its associated circuit form a constant current source; as more current tends to be drawn, more voltage is dropped across resistors R1088 and R1089, resulting in a decrease of forward bias; the base-to-supply voltage being clamped to a fixed value by diodes CR1044 and CR1045.

When run 6.8 voltage is created, the start 6.8 voltage source is inhibited due to a positive voltage applied to the base of start clock control transistor, Q1016. This turns off Q1014 allowing the start clock to complete its cycle but prevents a recycle. The run 6.8 voltage source provides instantaneous short circuit protection while the power supply is running. Should a short or overload cause the power supply output voltage to drop below 10 volts, the run 6.8 voltage is turned off which terminates the switching action of the power switch transistors and the power supply reverts to the start attempt mode.

(6) Voltage Regulator

The voltage regulator maintains power supply output voltage at the level set by the OUTPUT VOLTAGE ADJUST control during varying line voltage and load conditions. It maintains a constant output by controlling the width of each pulse from the variable width monostable except when the power supply is trying to start.

Power supply output voltage is monitored by detector, Q1039. The voltage on its base is limited to 6.8 volts by Zener diode, CR1047, but its emitter voltage is proportional to the output voltage. OUTPUT VOLTAGE ADJUST control, R1091, establishes the point at which power supply output voltage is maintained. Should output voltage tend to decrease due to an increased load, the emitter voltage on detector Q1039 decreases. However, base voltage remains the same and, therefore, detector, Q1039, conducts less causing regulator, Q1040, to conduct less. This decreases the drive to monostable control, Q1030, in the variable width monostable, thereby increasing the pulse width. An increased pulse width causes power supply output voltage to tend to increase, thus counteracting the effect of the increased load.

Should the power supply output voltage tend to increase due to decreased load, the functions are similar -- detector, Q1039, and regulator, Q1040, conduct more resulting in more drive to monostable control, Q1030. The pulse width is decreased, and power supply output voltage tends to decrease -- counteracting the effect of a reduced load.

(7) DC Switch

The dc switch, Q1043, parallels the bottom half of the output voltage adjust divider, R1091 and R1092. This switch controls the voltage detector circuit to provide the differential voltage between the float and equalize output levels to the battery. The float voltage provides a small charging current to keep the batteries at full charge, compensating for their internal losses. The emergency battery is always connected across the output terminals, TB1001, of the power supply. With the switch in the FLOAT position, the necessary voltage is applied to the batteries to maintain them at full capacity.

When the EQUALIZE-FLOAT switch is placed in the EQUALIZE position it actuates Q1043 and raises the output voltage sufficiently to "EQUALIZE" all cells of the emergency battery.

(8) Current Limiter

The current limiter protects the power supply from excessive current demands by causing power supply output voltage to drop when current exceeds a preset level (30 amperes). Note that, during overload conditions, the current limiter actually "takes over" control of power supply output voltage. Should the current demand be so great that power supply output voltage drops below 10 volts, run 6.8 volts disappears and the power supply reverts to the start attempt mode.

Output current is detected by the voltage drop across shunt resistor, R1013. This resistor is "across" both base inputs (pins 1 and 5) of differential amplifier, IC1001. The differential amplifier multiplies the small changes in voltage drop across R1013 so that little power is lost in current detection and regulation. CURRENT LIMIT ADJUST control, R1102, sets the current limit at which the current limiter begins to decrease power supply voltage output.

As supply output current increases, the voltage on the "input" side of R1013 remains nearly constant while the voltage on the "output" side of R1013 decreases. This results in a

lowering of voltage on IC1001-5 while the voltage on IC1001-1 remains the same. Therefore, the voltage difference between the collectors of IC1001 (pins -6 and -8) increases. Pin 6 rises in relation to pin 8 under these circumstances. Therefore, Q1041 and Q1042 begin to conduct. The more Q1042 conducts, the lower its collector to emitter resistance becomes. This increases the voltage applied to the base of Q1040 in the voltage regulator which causes it to conduct more. As described during the discussion of the voltage regulator, the more Q1040 conducts, the lower power supply output voltage will be.

(9) Start Short Circuit Protection

This circuit prevents the power supply from being damaged should a short-circuit load (less than 0.4 ohm) be applied during power supply start up. Short circuit protection after the power supply has reached rated output is accomplished by the removal of run 6.8 voltage. Since run 6.8 voltage is present only in the run mode, it cannot provide protection against shorts during start up.

Once start sweep has begun, power supply output voltage steadily increases from 0 volts to rated 14.0 volts in about one second during which time the switching rate of the power switches steadily increase. Switch, Q1034, is enabled during the start attempt period and the output voltage of the power supply is monitored by the start short circuit protection circuit at detector, Q1033. As power supply output voltage rises, the emitter and base voltage at detector, Q1033, will rise at the same rate and the detector remains off. Capacitor C1053 also charges positively through diode CR1040 as the supply output voltage rises. However, when the supply output is shorted, output voltage drops to zero. The emitter voltage on detector, Q1033, drops to zero and diode CR1040 back-biases. Now, capacitor C1053 holds the base of the detector positive momentarily and the transistor conducts. When detector, Q1033, conducts, switch, Q1034, also conducts applying a positive voltage pulse to the base of Q1027 in the 20 kHz astable momentarily stopping the astable, and locking on Q1033 via R1076 and CR1041 preventing further drive to the power switches. Since the short circuit protection circuit provides only a momentary "freeze" in switching action, the power supply will attempt to start again after a few moments providing input power is still applied.

(10) Crowbar - Overvoltage Protection

The crowbar circuit consists of an SCR and controlling components. This circuit insures

that excessive output voltage cannot occur to cause possible damage to the station. Should the power supply output voltage reach 18 volts, the crowbar SCR "fires" and fuse F1002 blows shutting down the power supply.

As power supply output voltage increases, a sample of that voltage is routed to Q1022 of the crowbar trigger circuit. The voltage applied to the base of Q1022 is prevented from rising higher than approximately 16 volts by Zener diode CR1026. The voltage on the emitter of Q1022, however, is permitted to follow the rise in output voltage so that, when the output voltage approaches 18 volts, the transistor turns on which switches a positive voltage to the base of Q1021 which then also turns on. A large, positive going pulse is then fed to the gate of crowbar SCR1001 which turns it on. Once the silicon controlled rectifier is on, it shorts the output of the rectifier bridge preventing any further rise in output voltage by blowing the line fuses.

c. Battery Protection and Alarm

(Refer to Battery Protection & Alarm Circuit Schematic Diagram.)

In normal operation with ac power applied, the battery is connected to the station through the contacts of low-voltage dropout relay K411 which is energized from the A+ output of the power supply. The negative end of the relay coil completes its path to ground through relay switching transistor Q418, which is held in saturation by a positive voltage from the collector of relay driver Q417.

The run 6.8 V source output of the 12 V regulator board is sensed constantly by the alarm switch. The presence of positive voltage keeps Q431 turned on, indicating that normal power is present and thus preventing an alarm tone.

(1) Primary Power Failure

If the power fails, there is no longer an output from the run 6.8 V source to keep the alarm switch turned on. With the alarm switch off the base of Q426 is no longer at ground potential.

This allows the astable to operate at a repetition rate of once every 2-1/2 seconds. During each portion of the astable cycle in which Q426 is on, it provides a ground return for the base of Q427 via resistor R466. At this time, Q427 is properly biased to permit the Q427-Q428 phase-shift oscillator to oscillate at a frequency of approximately 1.4 kHz. During the portion of the astable cycle when Q426 is off, Q427 is saturated and the phase shift oscillator is inoperative.

The gating provided by the astable multivibrator allows the tone to be generated for approximately 1/4 second during each 2-1/2 second interval. This intermittent 1.4 kHz tone is routed through TONE ADJ control R477 into the station's wire line if the station is operated by wire line control or into the exciter if the station is operated as a repeater without wireline control. The tone is generated as long as the station operates on battery power.

(2) Low-Voltage Dropout

During emergency power operation, the terminal voltage of the battery will eventually decrease. Q415 and Q416 form a Schmitt trigger to detect when the battery voltage has fallen to the level beyond which it is not safe to discharge the battery without causing irreparable damage to it.

As the battery terminal voltage drops, it reaches the point where the emitter-base junction of Q415 becomes forward-biased. Q415 turns on, turning off Q416 and developing an abrupt increase in positive voltage at its collector. This positive going voltage turns off relay driver Q417, which turns off relay switch Q418, removing the ground return for low-voltage dropout relay K411. The relay de-energizes and its contacts open, disconnecting the battery completely from the station. The trip point of the Schmitt trigger can be set by adjustment of low voltage adjust control R426. This control is factory-adjusted to operate between 10.0 and 10.5 volts dc.

For stations set up with continuous alarm tone rather than relay operation, the relay switch Q418, when biased off, provides drive to the base of Q430 to turn on Q430. This provides a ground return for the base of Q427, thus keeping the alarm tone oscillator operating continuously rather than being intermittently gated on by the tone astable.

(3) Primary Power Restored

(a) Low Voltage Detector Circuit

When power is restored, a normal A+ voltage is again applied to the battery protection and alarm circuit and the low-voltage detector Schmitt trigger resets itself with Q415 off and Q416 on. The positive emitter voltage on Q415 equals the voltage drop across R425, which is stabilized by the drop across Zener diode CR414. The Q415 base voltage is determined by the setting of LOW VOLT control R426 (part of a voltage divider including R427 and R428 between A+ and ground). This control is set so that positive voltage on the base of Q415 is slightly

less than the emitter voltage, keeping Q415 in cutoff.

The positive voltage at the Q416 collector is applied to the base of relay driver Q417, holding it in saturation. The positive voltage at the collector of Q417, in turn, holds relay switch Q418 in saturation providing a ground for low voltage dropout relay K411, energizing the relay. (If the discharge period was not long enough to cause the battery voltage to drop below the trip point of the low voltage detector, relay K411 would have remained energized and the battery remained connected to the load.

In stations set up with no relay operation, the positive voltage at the collector of Q417 holds relay switch Q418 in saturation shorting to ground the drive to the low voltage alarm switch. This turns off the alarm tone oscillator.

If the discharge period was not long enough to cause the battery voltage to drop below the trip point of the low voltage detector, low-voltage alarm switch Q430 will not be turned on. The alarm tone oscillator would operate only when gated on by the tone astable.

(b) Tone Generator Circuit

When power is restored, the run 6.8 V source output turns on the alarm switch, grounding the base of Q426. This inhibits the astable's operation by always keeping Q426 turned off. Due to non-conduction of Q426, a positive voltage from its collector is applied to the base of Q427, disabling the 1.4 kHz tone oscillator.

3. POWER SUPPLY START SEQUENCE

a. Introduction

The following discussion should be used only after power supply terms are understood as described in the previous Theory of Operation paragraphs. A condensation of power supply terms is given in the maintenance area of this section, under Troubleshooting. Refer to the power supply schematic and block diagrams.

b. Events

- (1) AC power applied.
- (2) DC voltage at C1006 rises to 60 volts.
- (3) After approximately 1/2 second, start clock turns on start 6.8 voltage source and start attempt begins.

(4) 20 kHz astable runs at 500 Hz.

(5) Variable width monostable delivers maximum pulse width to the power switches at a 500 Hz rate.

(6) Supply output voltage begins to rise.

(7) Start sweep control senses normal load and sweeps 20 kHz astable from 500 Hz to 20 kHz.

(8) As output voltage rises to the preset value, the voltage regulator takes control of the variable width monostable and adjusts pulse width to maintain constant output voltage over varying line voltage and load conditions. Run 6.8 voltage replaces start 6.8 voltage.

4. BATTERY CONNECTION AND INSTALLATION

a. Power Supply

Installation of the station with these options is standard except for the connection of the twelve-volt battery (10 cells nickel-cadmium; 6 cells lead-acid).

CAUTION

Wiring of the TPN1105A Power Supply is for 121 or 242 volts, 50 or 60 Hz. See schematic diagram and pictorial for transformer connections, and make sure the proper connections are made before applying power.

Locate the battery in a secure place, and as close to the station as possible. The cable length must be kept as short as practical, because of the voltage drop in the battery cable. A substantial voltage drop can be developed across this low resistance due to the high currents drawn from the battery while transmitting.

Select a battery location that has an unobstructed air circulation, preferably a cool dry place with ample width aisles to permit easy access to all cells for installation, taking readings, adding water and cleaning. The battery must not be placed near radiators, boilers, or other heat-producing devices.

Capacity of a battery should be carefully determined before its purchase. Factors that influence the capacity are the busy hour load, the protection time desired, the final cell voltage limit and the minimum operating temperatures. For more information contact your Motorola Area Systems Engineer.

Connection of the battery terminals made during installation is extremely important to its service life. If connections are carefully made with clean, acid-free surfaces and kept tight by periodic checking, they will give trouble free service over the life of the battery.

Connect the battery cable from TB1001 of the power supply chassis to the battery, red cable to (+) terminal and black cable to (-) terminal. To prevent accidental short circuit during installation, it is recommended that the ground cable be connected first. The hot cable should be connected to the power supply, then to the battery. Also the in-line fuse could be removed until the installation is complete.

If power is to be removed from the station for any reason after the initial installation, the most convenient method is to remove the in-line fuse (F1) from the battery cable.

Adjustment of the float voltage of the power supply may be required at the time the battery is installed. The float voltage is the A+ output voltage of the power supply which will keep a battery fully-charged when connected across the A+ output terminals. The float voltage adjustment varies with the type of battery being installed and with the ambient temperature. Refer to the level-setting paragraph for adjustment of the float voltage.

Give the battery a freshening or boost charge when it is received. Do this in accordance with the manufacture's instructions.

b. Battery Protection and Alarm

The C29 option, as shipped from the factory, is wired to include the low voltage dropout relay for battery protection. In this configuration the red battery cable is connected to TB401. If it is desired to have the low voltage detect circuit to cause a continuous tone alarm rather than to disconnect the battery, connect the red battery cable to the power terminal TB1001 (+) instead of to TB401 (dropout relay). The two relay leads (BRN-WHT and BLACK) should be pulled off of the push pins on the alarm tone generator board. As shipped from the factory, jumper JU1 has been installed for repeater stations without wire line control.

5. LEVEL SET ACCESS AND ADJUSTMENTS

a. Output Voltage Adjust Control Access

Loosen the seven screws securing the large perforated back cover on the filter section.

This exposes the OUTPUT VOLTAGE ADJUST and CURRENT LIMIT ADJUST which are controls identified on the power supply 14.0 V regulator circuit board detail at the end of this section.

b. Output Voltage Adjustment

The OUTPUT VOLTAGE ADJUST control is identified on the power supply identification photo located in this power supply section.

CAUTION

Do not turn the OUTPUT VOLTAGE ADJUST control to either extreme position except as required during troubleshooting.

Full counterclockwise rotation will cause output voltage to drop to a point where the power supply will not run but will continuously recycle through start attempts. Full clockwise rotation causes the overvoltage protection circuit to blow the ac line fuse.

The A+ output is factory adjusted for nickel-cadmium batteries at 14.25 volts. If adjustment is necessary, set output voltage control, R1091, in the station power supply for the desired float voltage as follows:

(1) Connect a dc voltmeter with 3% accuracy (or better) between terminals TB1001+ and TB1001- on the power supply.

(2) Set output voltage control R1091 for 14.25 volts for nickel-cadmium batteries, 13.0 volts for lead acid batteries on the voltmeter.

c. Current Limiter Test and Adjustment

This control is factory set to limit at 30 amperes and should not require routine

re-adjustment. The function of the current limiter can be observed without disassembly of the station.

(1) Connect a variable load, voltmeter, and current meter (refer to maintenance section for list of recommended test equipment) to the + and - DC terminals on power supply terminal strip TB1001.

(2) Set the load at maximum resistance and turn on the power supply.

(3) Gradually increase the load while observing output voltage and current.

When limit current is reached (approximately 29 amps in this case) the output voltage will begin to decrease significantly.

(4) Increasing the power supply load further causes the current to "fold back" to a lower value. Ultimately, the power supply will shut down and begin repeated attempts to start. Decreasing the load at this point allows the supply to restart.

NOTE

Readjustment is not necessary unless the limiting current is more than 2 amperes high or low. CHECK FOR PROPER ADJUSTMENT OF THIS CONTROL BEFORE ATTEMPTING READJUSTMENT.

(5) If a current of 32 amperes is reached with no limiting action, do not increase the load further. Instead, turn the LIMIT CURRENT ADJUST control counterclockwise until limiting action appears.

d. Alarm Tone Level Adjustment

In remote control stations, and in repeaters with wire line control, the "tone level" control (R477 on the board) is factory preset to provide a level -20 dB below the set level on the audio control line. In "repeater only" stations, this control is set for a deviation of ± 0.5 kHz.

The tone level control may be reset to suit the needs of a particular installation by the following procedure.

(1) Disconnect the station from the ac power line and allow it to operate on its battery. (This should turn on the alarm tone oscillator.)

(2) Set the volume control at a normal comfortable operating level with a received signal.

(3) Rotate TONE ADJ control R477 (red potentiometer) until the alarm tone is clearly discernible, but not loud enough to effect the intelligibility of the audio signals on the line. The tone can be turned on continuously, instead of the short bursts, to facilitate adjustment. This is accomplished by inserting a screwdriver in a hole located on the cover plate in back of the power supply. The hole is just above the TONE LVL adjustment hole next to the EQUALIZE-FLOAT switch. Touch the board with the tip of the screwdriver, then short the screwdriver to the cover plate. This shorts the collector of Q426 to the chassis allowing a continuous tone to be heard.

e. Low-Voltage Detector Adjustment

LOW VOLT control R426 (blue pot) is factory preset, but may need resetting if any components in the low-voltage detector or associated circuits have been replaced. If necessary to readjust the low-voltage detector control, use the following procedure.

(1) Disconnect both ac and battery power from the station.

(2) Connect the output of a variable dc power supply (such as the Motorola S1346A) to TB1001 in the power supply.

(3) Preset low-voltage control R426 in the fully counterclockwise position.

(4) Set the output of the variable power supply at 10.0 volts.

(5) Rotate LOW VOLT control R426 clockwise until "low voltage dropout relay" K411 de-energizes. Read the power supply output voltage just before the point of dropout.

(6) Check the relay operation by increasing the supply voltage until the relay pulls in and then reducing it until the relay drops out. Read the supply voltage at the point just before dropout. The relay should drop out when the supply voltage is between 10.0 and 10.5 volts.

(7) If the measured dropout voltage was outside the 10.0- to 10.5-volt range, readjust control R426 and recheck until it is within these limits. Clockwise rotation of R426 increases the dropout voltage; counterclockwise rotation decrease it.

(8) Turn off the variable power supply and completely disconnect it from TB1001.

NOTE

For stations that indicate low voltage with a continuous tone rather than by relay operation, the preceding procedure should be performed by noting the transition of the alarm tone from intermittent to continuous rather than the relay's transition from energized to de-energized.

6. MAINTENANCE

a. Power Supply

(1) Introduction

Maintenance and repairs of this power supply demands a thorough understanding of its operation. Refer to the power supply Theory of Operation for this information.

(2) Test Equipment Required

The following test equipment is necessary for efficient, accurate servicing in the event that maintenance is required.

(a) DC voltmeter (Motorola Model T1022A, or equivalent).

(b) Ohmmeter (Motorola Model T1022A, or equivalent).

(c) DC current meter (0-35 amperes).

(d) Load resistor (variable from 0.3 ohm to 15 ohms, and capable of carrying 30 amperes).

(e) Variable voltage ac line transformer (0-130 volts).

(f) Oscilloscope.

(3) Disassembly

Figures 2 through 9 describe the access procedure to all power supply circuit boards and "areas". Access can be made to the areas with the power supply mounted in the station.

NOTE

The power supply weighs approximately 50 pounds.

(4) Troubleshooting

(a) Introduction

Eight major malfunction headings (conditions) are given after the introduction to troubleshooting. Unless otherwise noted, perform the tests with a full load (30 amps) connected to the high current output (+ and - terminals on TB1001 on the power supply) to the power amplifier. The resistance of such a load is approximately 0.45 ohms.

(b) Conditions

From the following eight major malfunction headings, select the one that describes the power supply malfunction. Follow the step-by-step check list to localize the trouble and identify the specific malfunction. Analyze the possible trouble using the schematic diagram with information given in the Theory of Operation paragraphs of this section.

CAUTION

When making measurements, be extremely careful not to create shorts or accidental connections which could cause power supply damage.

Power supply terminology follows as an aid to using the troubleshooting information.

(1) Run

Power supply switching at 20 kHz and capable of full load with output voltage regulation.

(2) Sweep

The rapid increase in power supply switching frequency from 500 Hz to 20 kHz. This sweep is audible until it reaches 20 kHz.

(3) Start Attempt

Time interval when the start clock supplies start 6.8 V and supply switches at 500 Hz.

(4) Start

Start attempt followed by a sweep, leading to a run condition.

(5) Crowbar

Switching device used to purposely overload one circuit to protect others.

(6) Full Load

Thirty (30) amperes at 13.35 V dc.

b. Battery Maintenance

The battery or batteries used for emergency power require certain routine maintenance procedures to assure long trouble-free operation. Persons servicing the batteries should refer to the manufacturer's recommendations for routine maintenance. In addition, certain maintenance procedures are appropriate following each interval of emergency power operation.

Routine battery maintenance procedures for the two most common battery types are given (nickel-cadmium and lead-acid). The importance of keeping good battery maintenance records cannot be over-emphasized. A chart or table is needed, listing all voltage readings, temperature and hydrometer readings (where applicable), versus the dates on which the readings were taken. To be most effective, the battery report charts should be kept at the battery location for ready reference.

(1) Nickel-Cadmium Batteries

Perform the following routine maintenance procedures at six-month intervals.

(a) Clean the battery and inspect it for damage.

(b) Measure cell voltages and enter the voltage readings on your maintenance report.

Most maintenance schedules require voltage readings of every cell each time maintenance is performed. If a difference of .05 volt or more exists between any two cells, apply an "equalizing charge" to the battery for 48 hours or until three consecutive cell measurements show no change (readings to be taken at 1/2-hour intervals). The terminal voltage of the battery should then read $15.25 \pm .2$ volts.

(c) Add water as required to keep the electrolyte solution in each cell above minimum. Use distilled water only. Check the battery manufacturer's service literature for instructions on filling.

CAUTION

Do not use any tool on a nickel-cadmium battery which may have been used with lead-acid batteries. To do so may destroy the nickel-cadmium battery due to chemical contamination by electrolyte or other foreign matter from the lead-acid battery existing on the tool in question.

If frequent replacement of water is required, the charging rate may be too high. In this case, carefully check the A+ voltage with the switch in the FLOAT position for the specified 14.25 volts. Under certain high ambient temperature conditions, the battery may require water even though the charging voltage is correct. In this case, the charging voltage should be reduced until infrequent addition of water is required.

(2) Lead-Acid Batteries

Perform the routine maintenance procedures monthly.

(a) Clean the battery and inspect it for damage.

(b) Measure cell voltages and enter the voltage readings on your maintenance report. Most maintenance schedules require voltage readings of every cell each time maintenance is performed. If a difference of .05 volt or more exists between any two cells, apply an "equalizing charge" to the battery for the number of hours recommended by the manufacturer.

(c) Take specific gravity readings with a hydrometer calibrated for the type of electrolyte used.

1. Observe the necessary precautions to see that the readings are accurate, that no chemical contamination of the cells occurs,

and to prevent bodily injury from contact with the electrolyte.

2. After taking a reading, always return the electrolyte in the hydrometer syringe to the cell from which it came. (Failure to do so will decrease the specific gravity of the cell when water is added to fill up the cell.)

3. For an accurate comparison with "standard" specific gravity readings, as published in manufacturer's specifications, a correction factor must be applied to all readings to normalize them with the standard values, when taken at temperatures other than 77° Fahrenheit. However, if the battery temperature tends to be the same each time specific gravity readings are taken, a trend toward a change in specific gravity will be apparent without having to apply the correction factor to the readings.

The correction factor is easily applied, due to a linear relationship between changes in temperature and specific gravity above and below 77° F. For each three degrees above 77° F, add .001 (known as "1 point") to the "standard" value of specific gravity. Conversely, for each three degrees below 77° F, subtract 1 point.

4. Take a specific gravity reading of the "pilot cell" monthly. It is not necessary to continually check the specific gravity of all cells, because any gradual changes usually occur simultaneously in all cells. One cell is therefore chosen and designated the "pilot cell", and the monthly routine specific gravity readings are always taken from this one cell. (Be sure to indicate on the maintenance chart which cell is the pilot cell.)

Take specific gravity readings of all the battery cells every three months, and record them on the maintenance chart.

(d) Add water as required to keep the electrolyte solution in each cell up to a minimum level. In some batteries, the electrolyte level should be between the high- and low-level marks on the inside of each cell. If the cells have no such markers, check the manufacturer's literature. Use distilled water only.

NOTE

Do not use any tool on a lead-acid battery which may have been used with nickel-cadmium batteries. To do so may destroy the lead-acid battery, due to chemical contamination by electrolyte or other foreign matter from the nickel-cadmium battery existing on the surface of the tool in question.

If frequent replacement of water is required, the charging rate may be too high. In this case, carefully check the A+ voltage for the specified 13.0 volts with the switch in the FLOAT position. Under certain high ambient temperature conditions, the battery may require frequent water replacement even though the correct charging voltage is maintained. In this case, the specified 13.0 volts may be reduced until infrequent addition is required.

(e) Equalize charging of a lead-acid battery should be performed under any one of the following conditions:

1. Following each known use (or discharge) of the battery.

2. If the specific gravity of the pilot cell or any other cell is more than ten-thousandths (10 points) below its full-charge value.

3. If the difference in voltage between any two cells is .05 volt or more.

4. As part of each Monthly Routine Maintenance Procedure independent of any of the previous conditions stated.

Equalize charging should continue for (a) the number of hours specified by the battery manufacturer, which will vary according to temperature, charging voltage and the manufacturer's recommendations or (b) until three successive readings of cell voltage and specific gravity show no change (readings to be taken at 1/2 hour intervals).

(3) Remote Control

Equalize charging may be remotely controlled in tone remote control "Mico" base and repeater stations. This can be accomplished with a TLN1252A "Wild Card" Module and a TLN4151A Relay as shown in Figure 1. Leave the FLOAT-EQUALIZE switch in the FLOAT position.

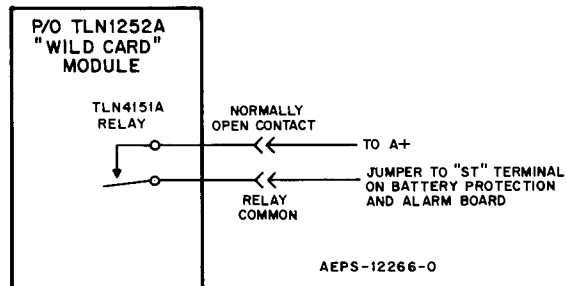

Figure 1. Remote Control of Float-Equalize

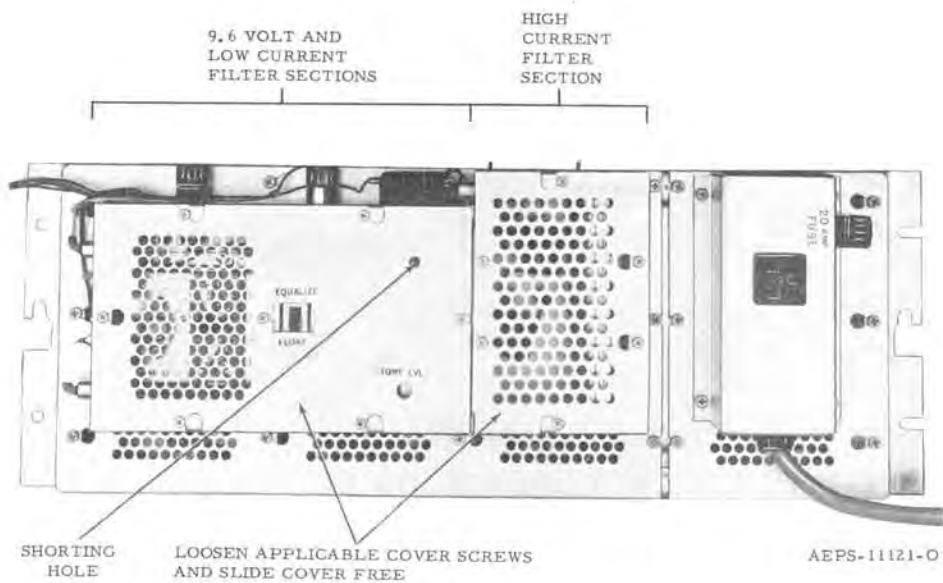
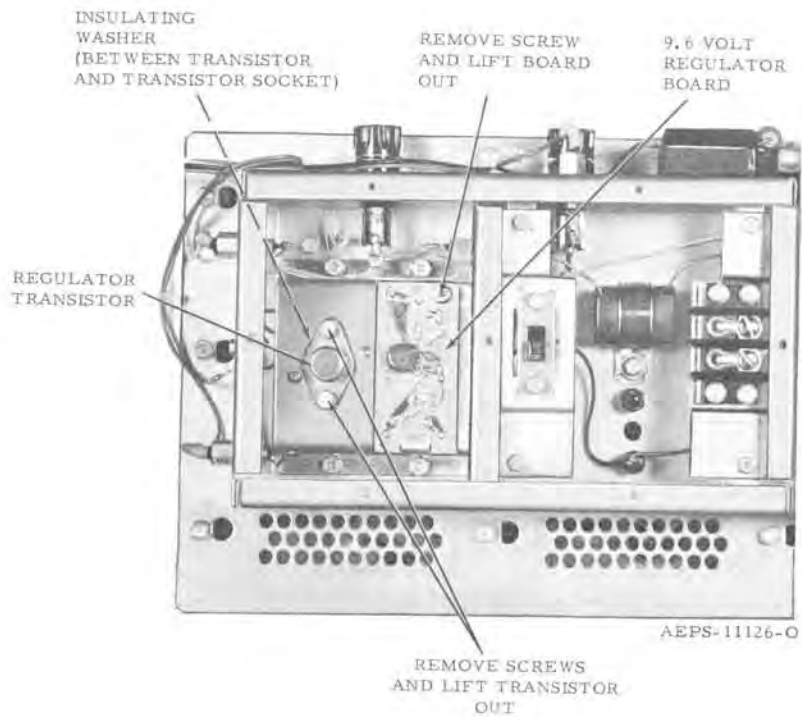
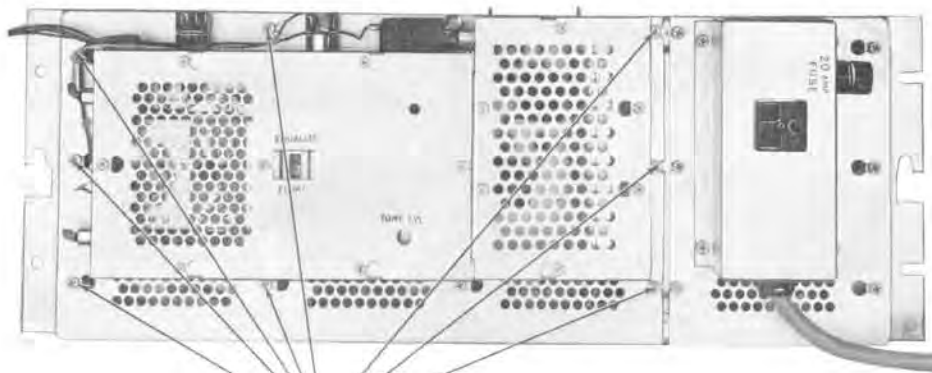

Figure 2.
Access to 9.6 Volt, Low Current, and
High Current Filter Sections



CAUTION
COAT BOTH SIDES OF INSULATING WASHER
WITH HEAT CONDUCTING SILICONE COMPOUND
BEFORE REPLACING THE TRANSISTOR.

Figure 3.
9.6 Volt Regulator Board
Removal and Regulator Transistor Replacement



LOOSEN INDICATED SCREWS AND SLIDE
COVER AND FILTER ASSEMBLY FREE

Figure 4.
Access to 13.8 Volt Regulator Board
and Shunt Resistor Board

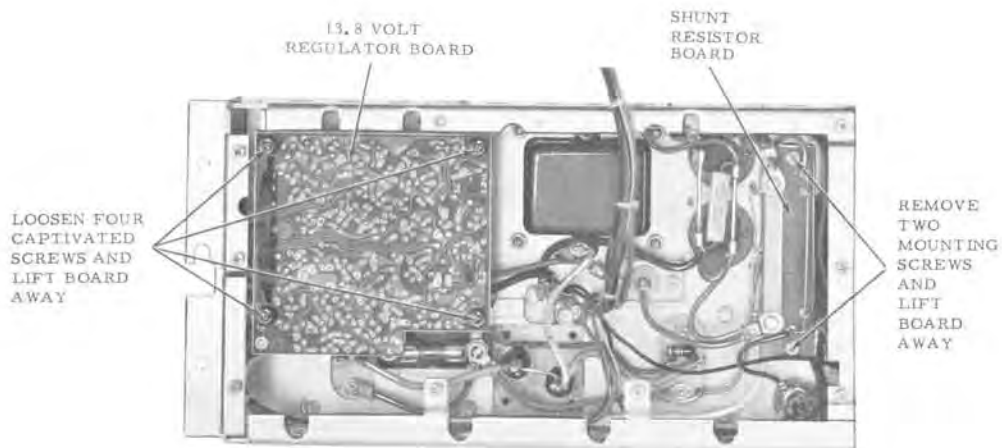

LOOSEN FOUR
CAPTIVATED
SCREWS AND
LIFT BOARD
AWAY

REMOVE
TWO
MOUNTING
SCREWS
AND
LIFT
BOARD
AWAY

AEPS-11954-Q

CAUTION

DO NOT REMOVE OR INSTALL THIS BOARD WITH POWER APPLIED. ALWAYS
ALLOW SEVERAL SECONDS FOR CAPACITORS TO DISCHARGE AFTER REMOVAL
OF POWER BEFORE EXTRACTING THE BOARD.

Figure 5.
Removal of 13.8 Volt Regulator Board
and Shunt Resistor Board

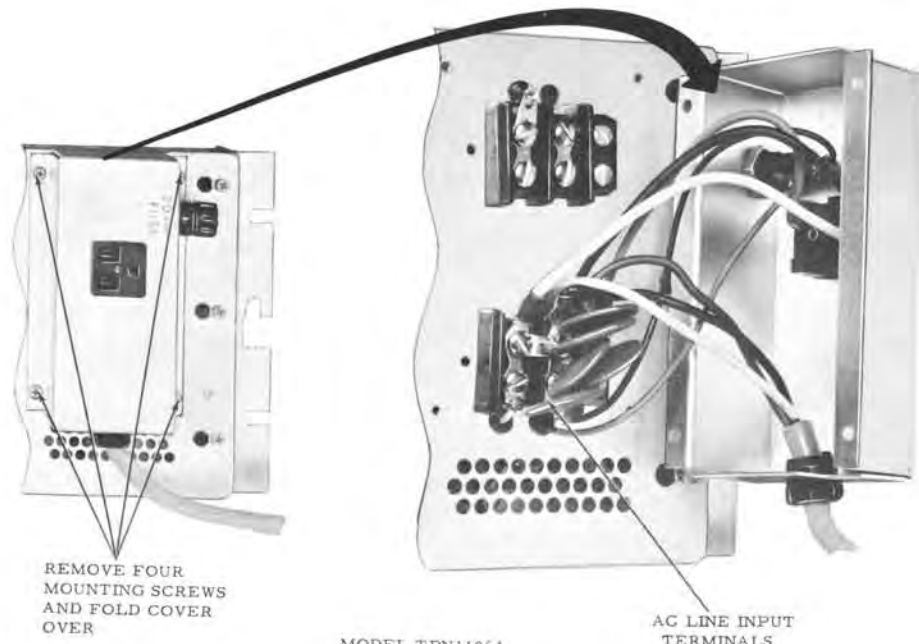

MODEL TPN1106A
121 VOLT 60 HZ

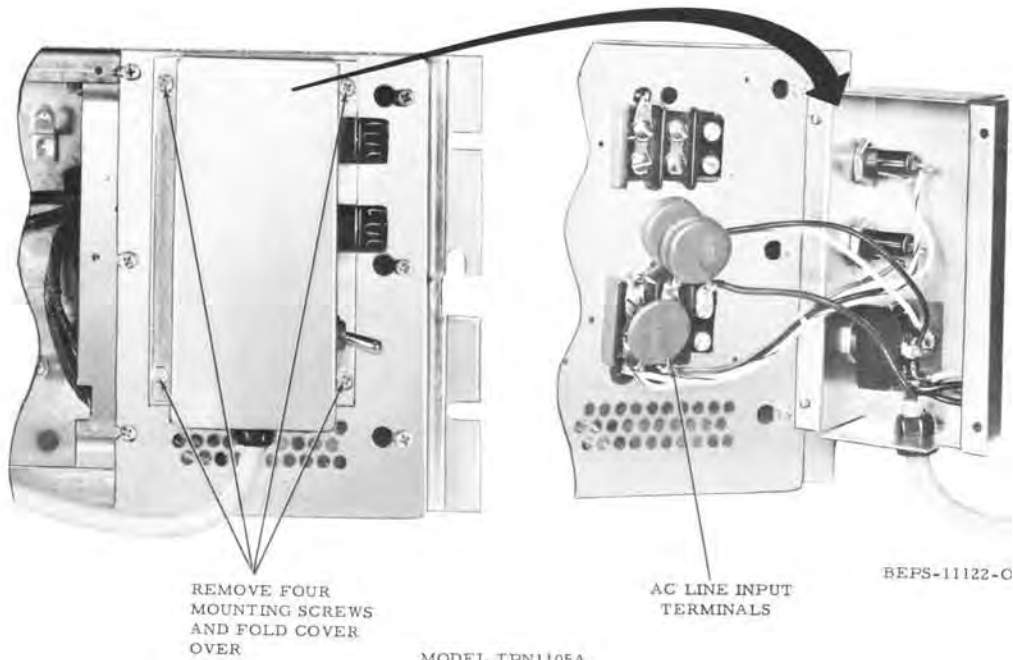

MODEL TPN1105A
121-242 VOLT 50-60 Hz

BEPS-11122-C

Figure 6.
Access to AC Line Input Terminals

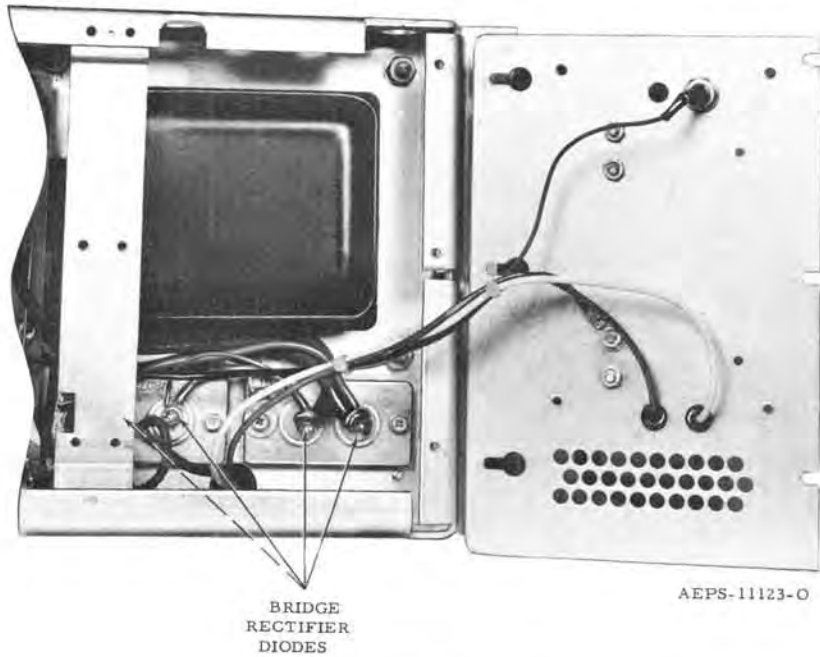
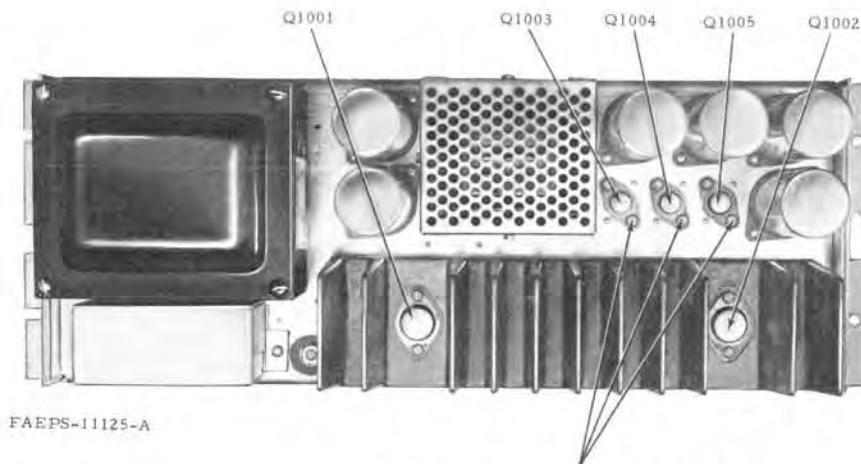

Figure 7.
Access to Bridge Rectifier Circuit



REMOVE TWO SCREWS FOR EACH
TRANSISTOR AND PULL TRANSISTOR OUT

CAUTION
EACH TRANSISTOR IS SEPARATED FROM ITS
SOCKET BY AN INSULATOR. COAT BOTH
SIDES OF THE INSULATOR WITH HEAT CONDUCTING
COMPOUND BEFORE REPLACING THE TRANSISTOR.

Figure 8.
Chassis Mounted Transistor
Replacement

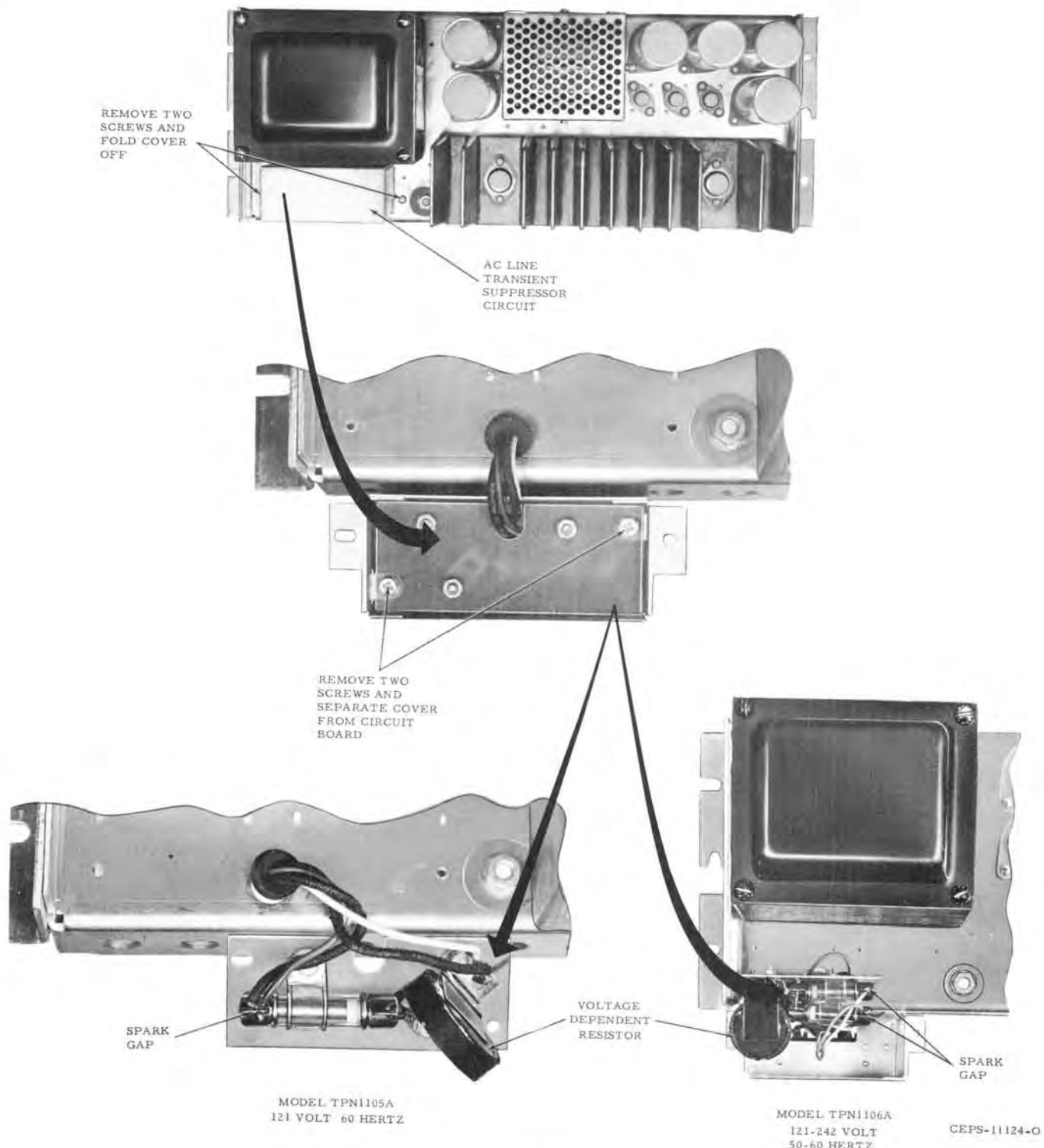
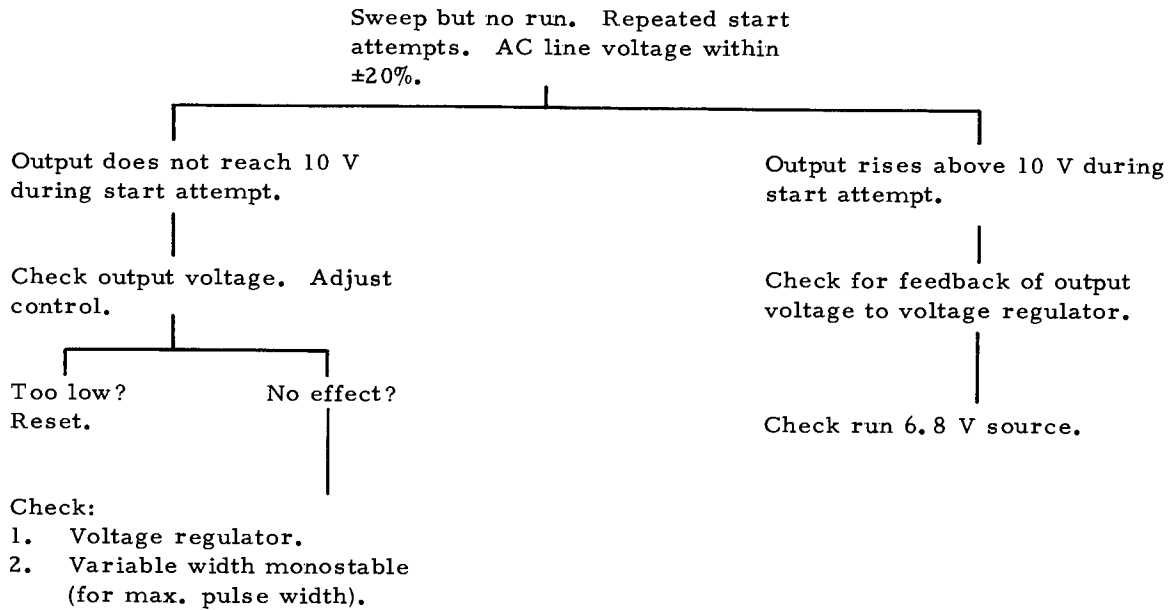
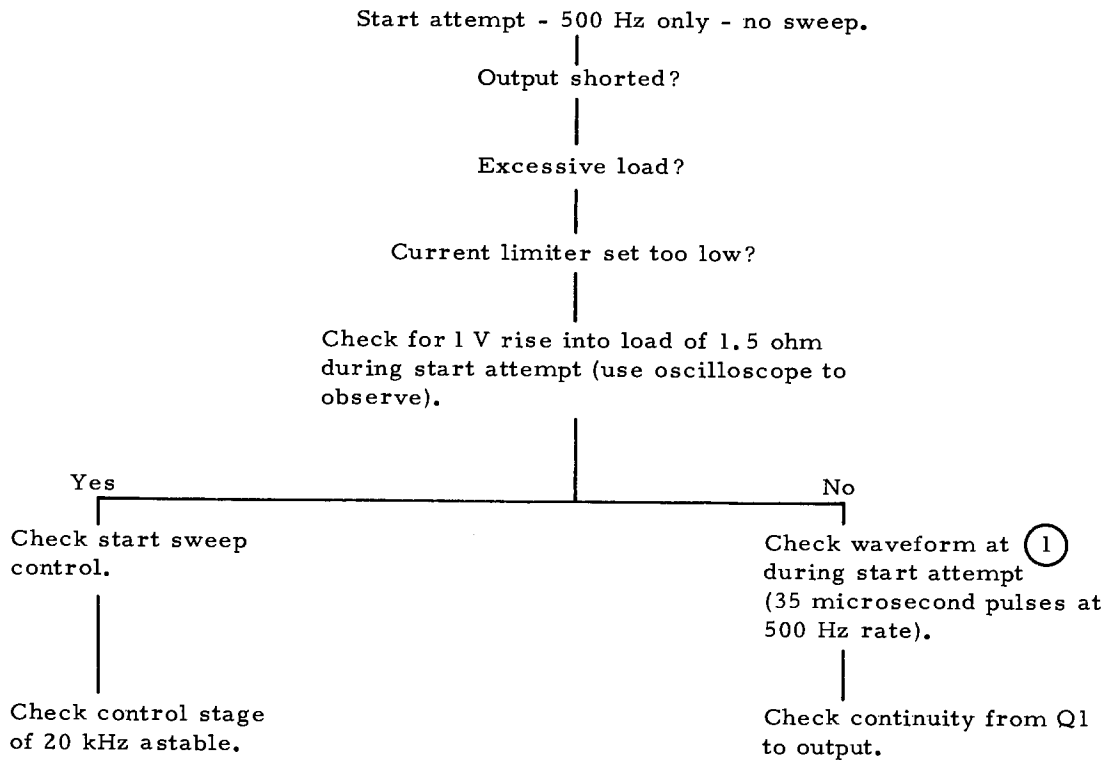

Figure 9.
Access to AC Line Transient Suppressor Circuit

(a) Condition #1



(b) Condition #2



(c) Condition #3

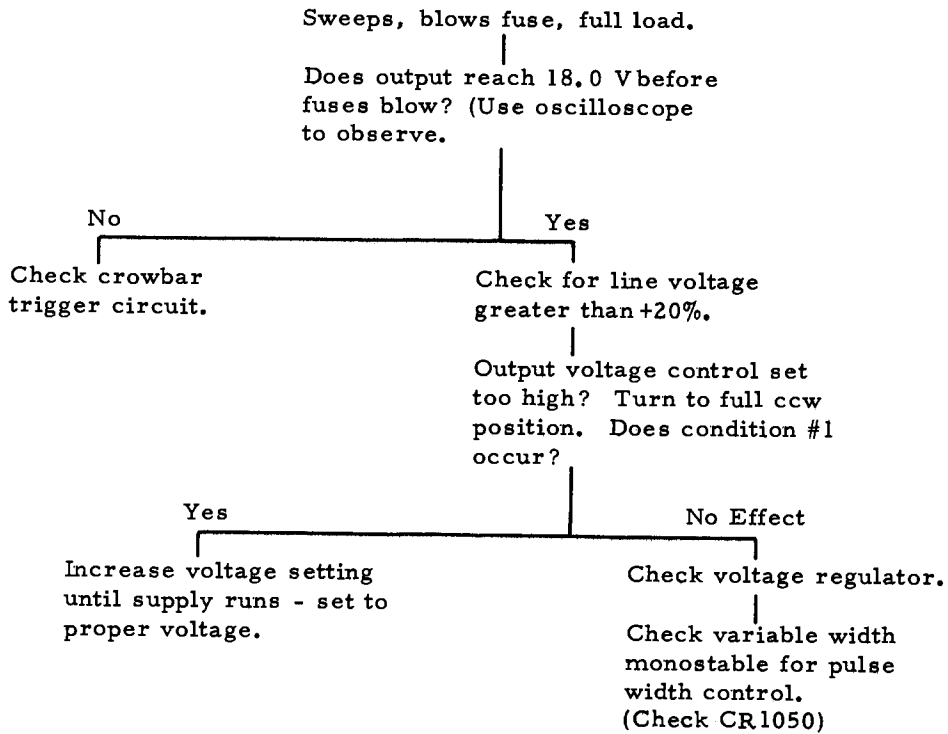

(d) Condition #4

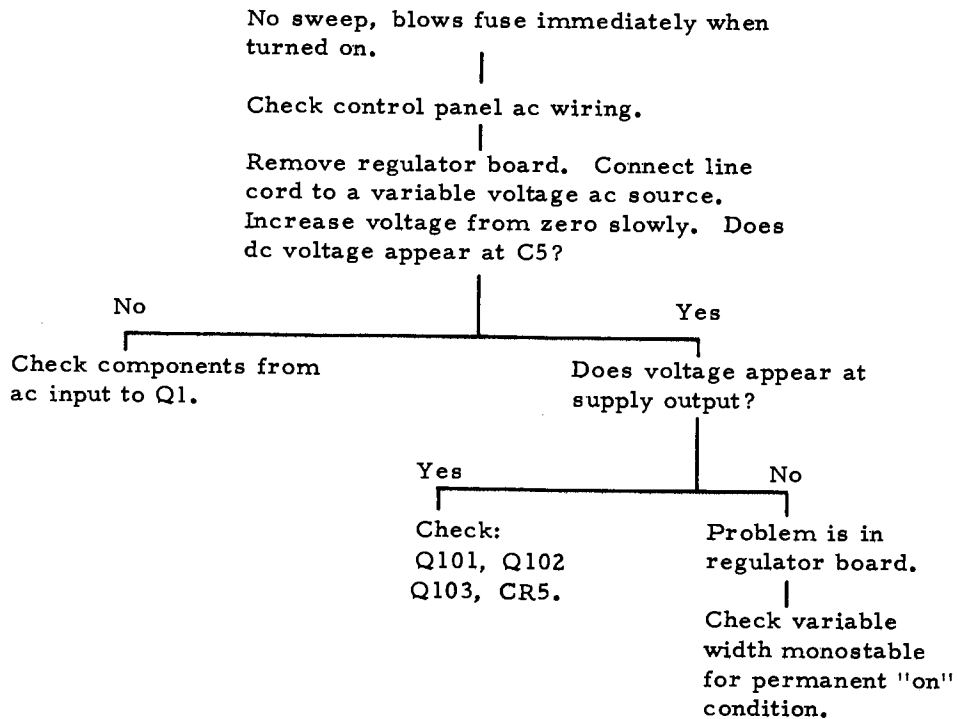

(e) Condition #5

No start attempt -- fuses OK.

Check voltage at C5.

Check start clock.

Check start 6.8 V source.

Check 20 kHz astable.

Check variable width monostable.

Check Q3, Q2, Q1.

Check continuity from Q1 to output.

(f) Condition #6

Runs but output voltage is low.

Check setting of output voltage adjust control.

Check setting of current limit adjust control.

Check voltage regulator.

Check variable width monostable.

Check 20 kHz astable.

(g) Condition #7

Runs normally at no load, but output voltage drops at load.

Current limiter set too low -- readjust.

(h) Condition #8

Will start at no load but not at full load.

Check for low ac line voltage.

Check comparator of start sweep control.

ELECTRICAL PARTS LOCATION
FRONT VIEW

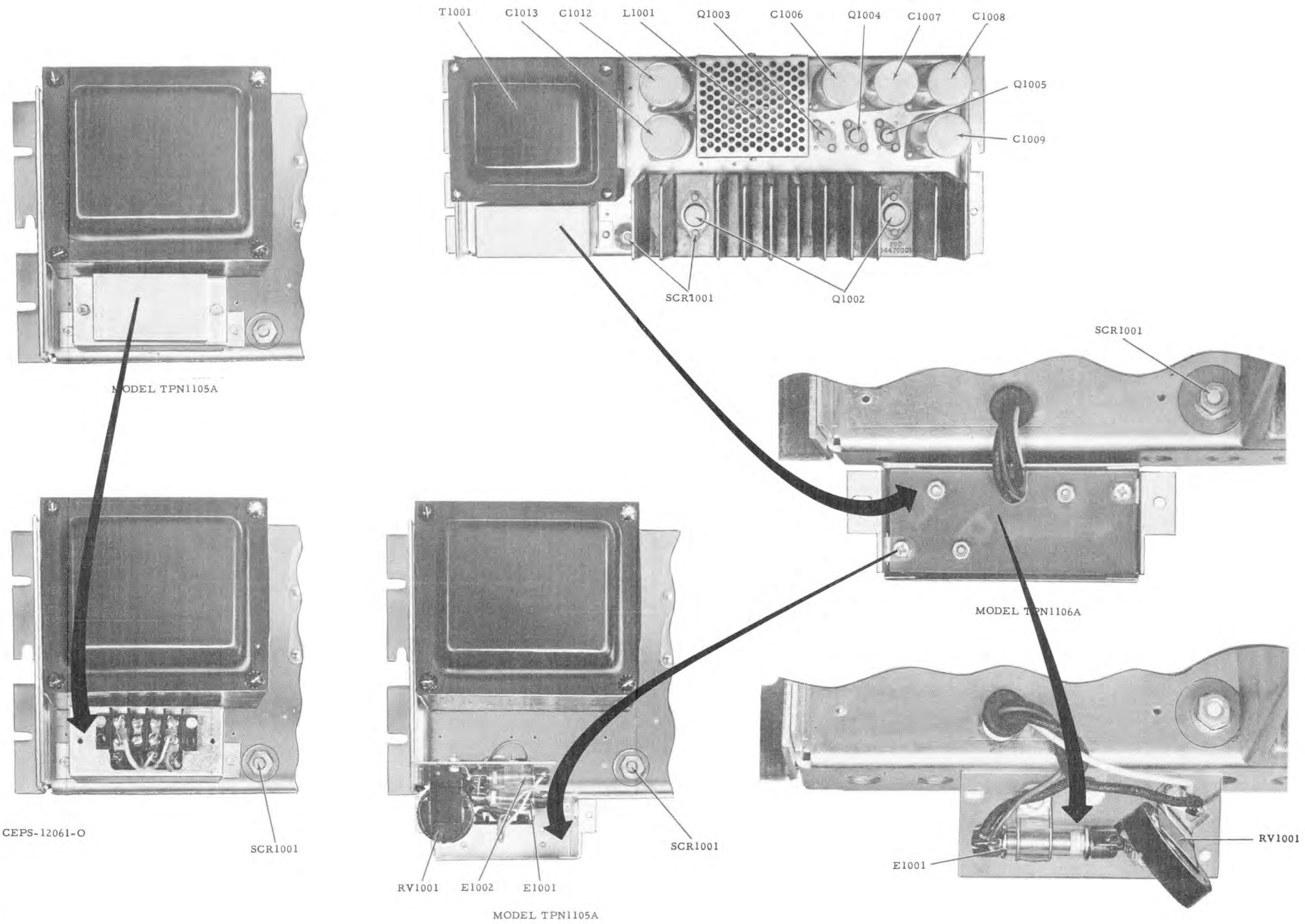

TPN1105A & TPN1106A Power Supply/Battery
Charger Electrical Parts Location
Front View
Motorola No. CEPS-12061-O
6/20/73-UP

ELECTRICAL CALL OUTS
REAR VIEW

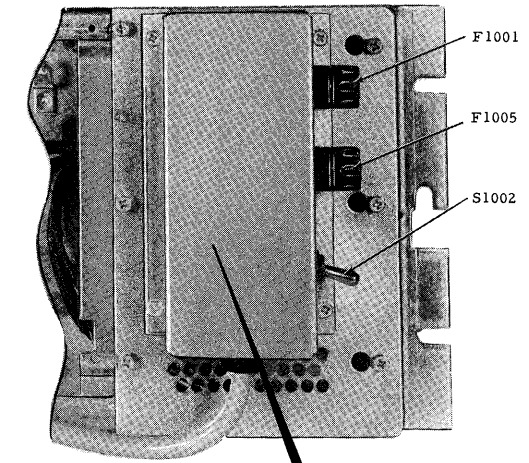
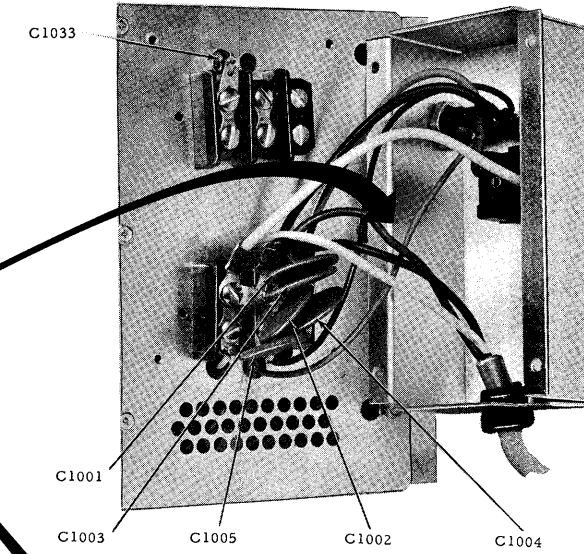
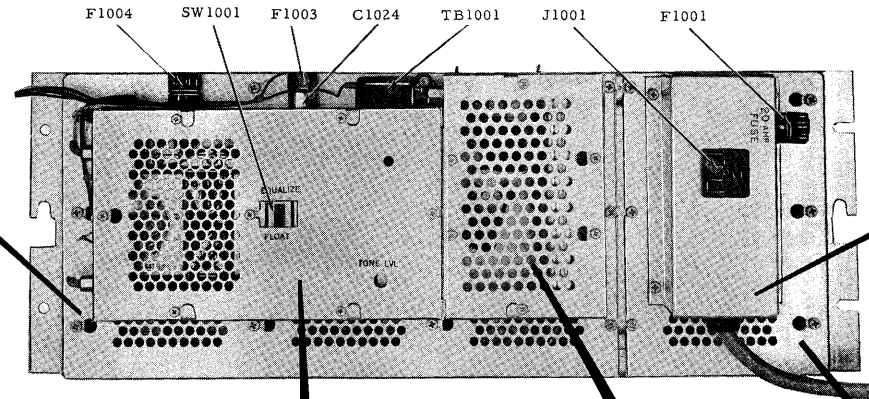
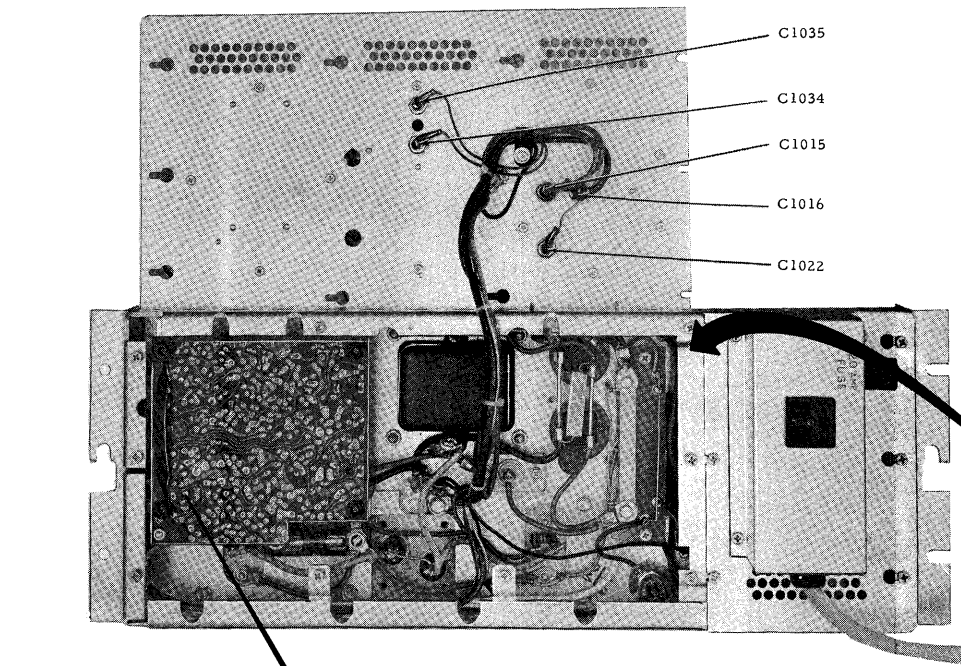

MODEL TPN105A

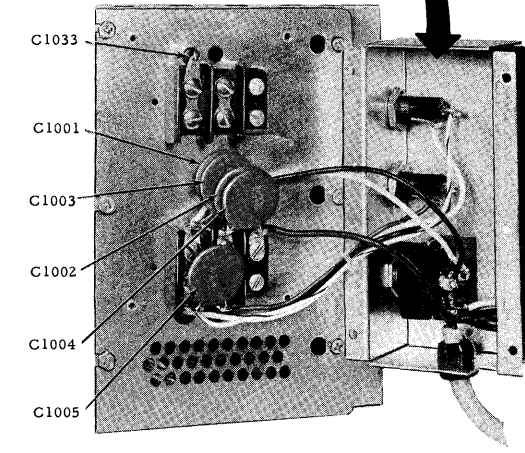
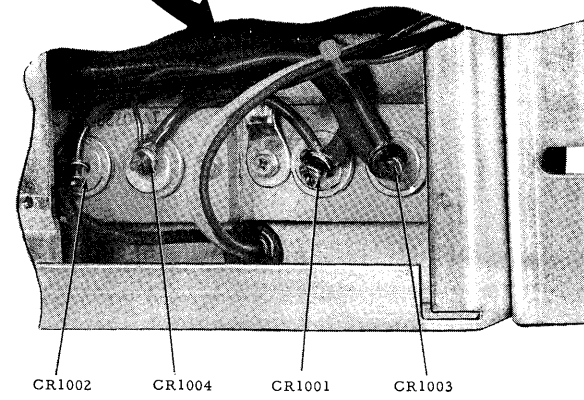
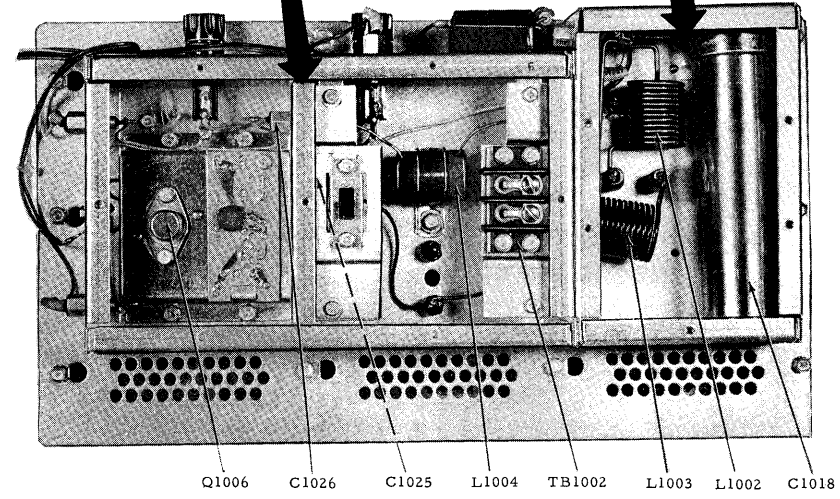
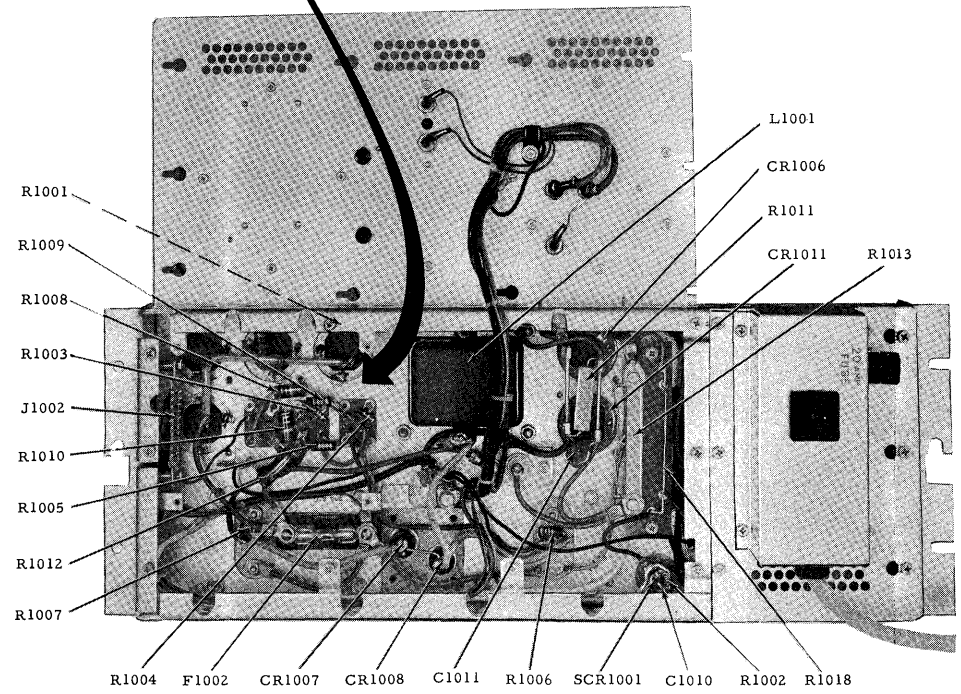

DEPS-11956-O

TPN1105A & TPN1106A Power Supply/
Battery Charger Electrical Parts Location
Rear View
Motorola No. DEPS-11956-O
6/20/73-UP

CODE	MOTOROLA PART NO.	DESCRIPTION
1	3-134169	SCREW, tapping: 4-40 x 1/4" Fillister hex head with external type lockwasher
2	15-84334D01	COVER SHIELD
3	3-124444	SCREW, machine: 6-32 x 1" plain hex head with external type lockwasher
4	3-3398	SCREW, tapping: 6-32 x 3/8" plain hex head with external type lockwasher
5	26-84470D01	RADIATOR, heat sink
6	3-122318	SCREW, tapping: 6-32 x 5/16" plain hex head with external type lockwasher
7	37-802943	GROMMET, rubber
8	15-84666D01	COVER, "VDR"
9	3-134294	SCREW, tapping: 6-32 x 3/8" plain hex head with external type lockwasher
10	4-7587	WASHER, flat
11	42-82387D08	CLAMP, plastic
12	3-136138	SCREW, tapping: 6-32 x 3/8" plain hex head with external type lockwasher
13	15-84338D01	COVER (low current & 9.6 V filter)
14	15-84338D02	COVER (high current filter)
15	42-82143C02	CLAMP, "nylon"; 1/4"
16	3-134184	SCREW, tapping: 4-40 x 5/16" plain hex head with external type lockwasher
17	55-84300B01	HANDLE, circuit board
18	2-7005	NUT, machine: 6-32 x 1/4" hex
19	4-7569	WASHER, flat
20	4-82345A11	WASHER, shoulder
21	29-845081	LUG, ring-tongue
22	29-3006	LUG, double-ended
23	3-129892	NUT, machine: 8-32 x 5/16" hex with external type lockwasher
24	4-8213	WASHER, flat
25	42-82018H01	RETAINER, line cord

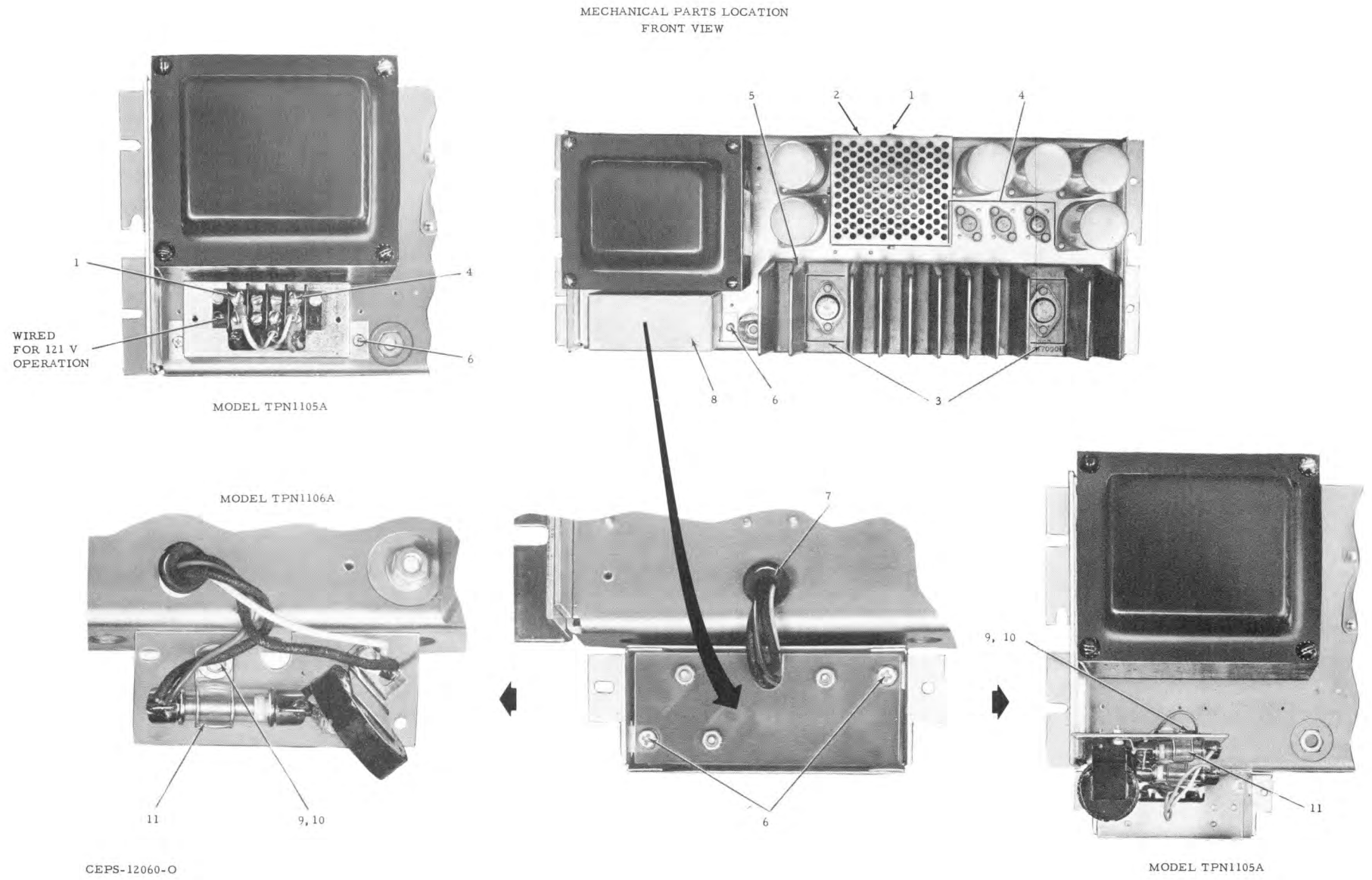

TPN1105A & TPN1106A Power Supply/ Battery
Charger Mechanical Parts Location
Front View
Motorola No. CEPS-12060-O
6/20/73-UP

MECHANICAL PARTS LOCATION
REAR VIEW

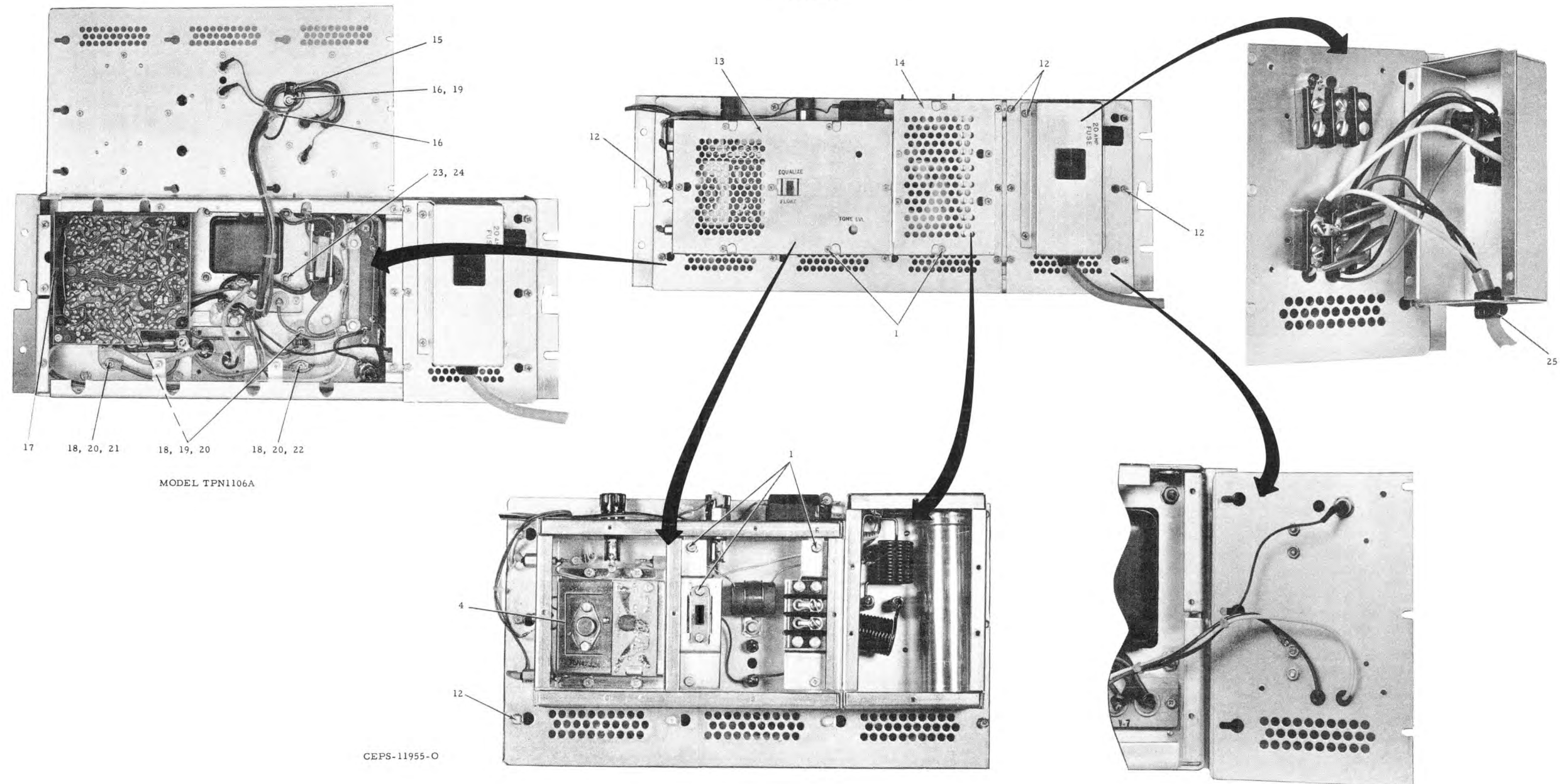

TPN1105A & TPN1106A Power Supply/
Battery Charger Mechanical Parts Location
Rear View
Motorola No. CEPS-11955-O
6/20/73-UP

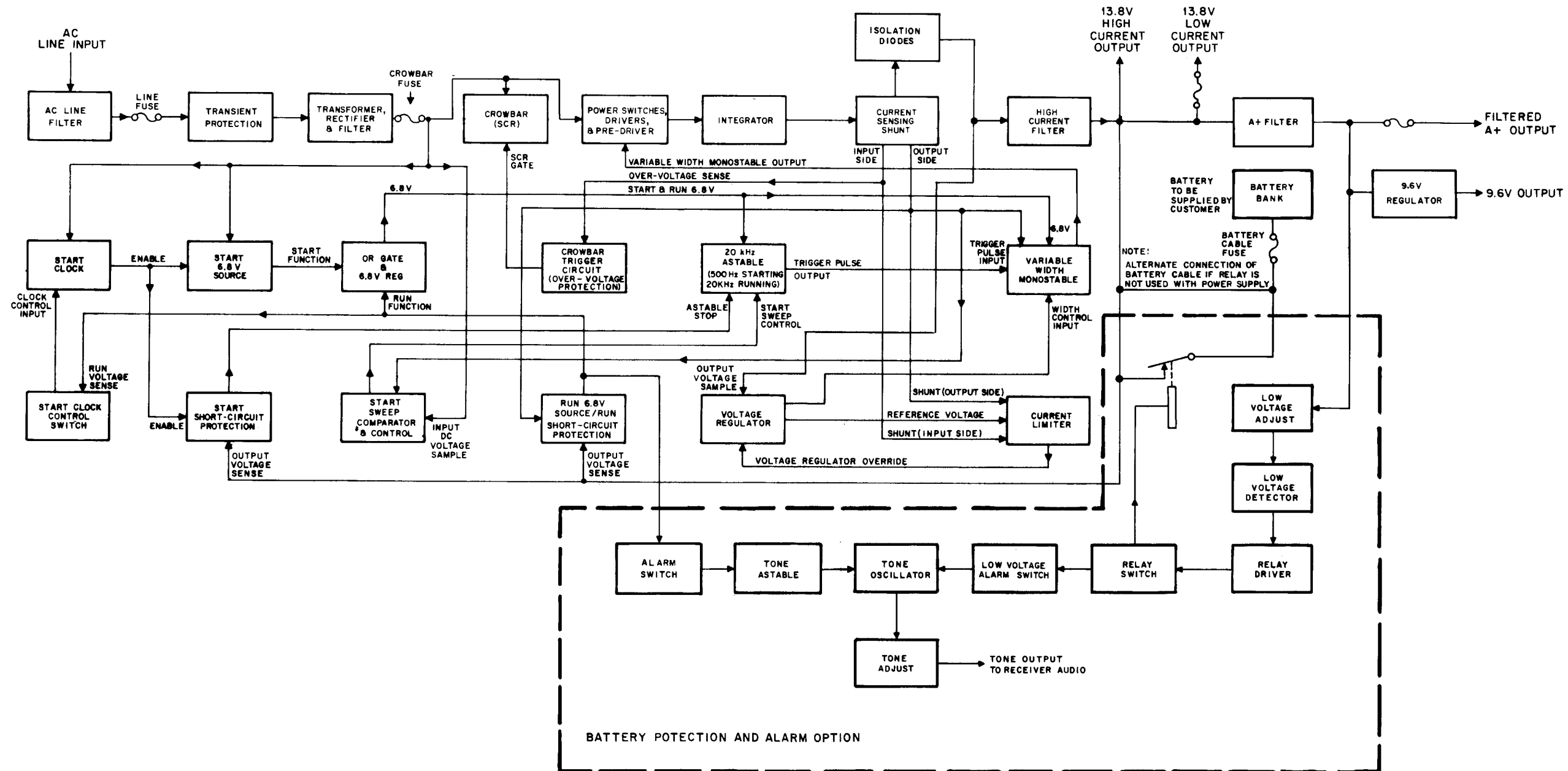

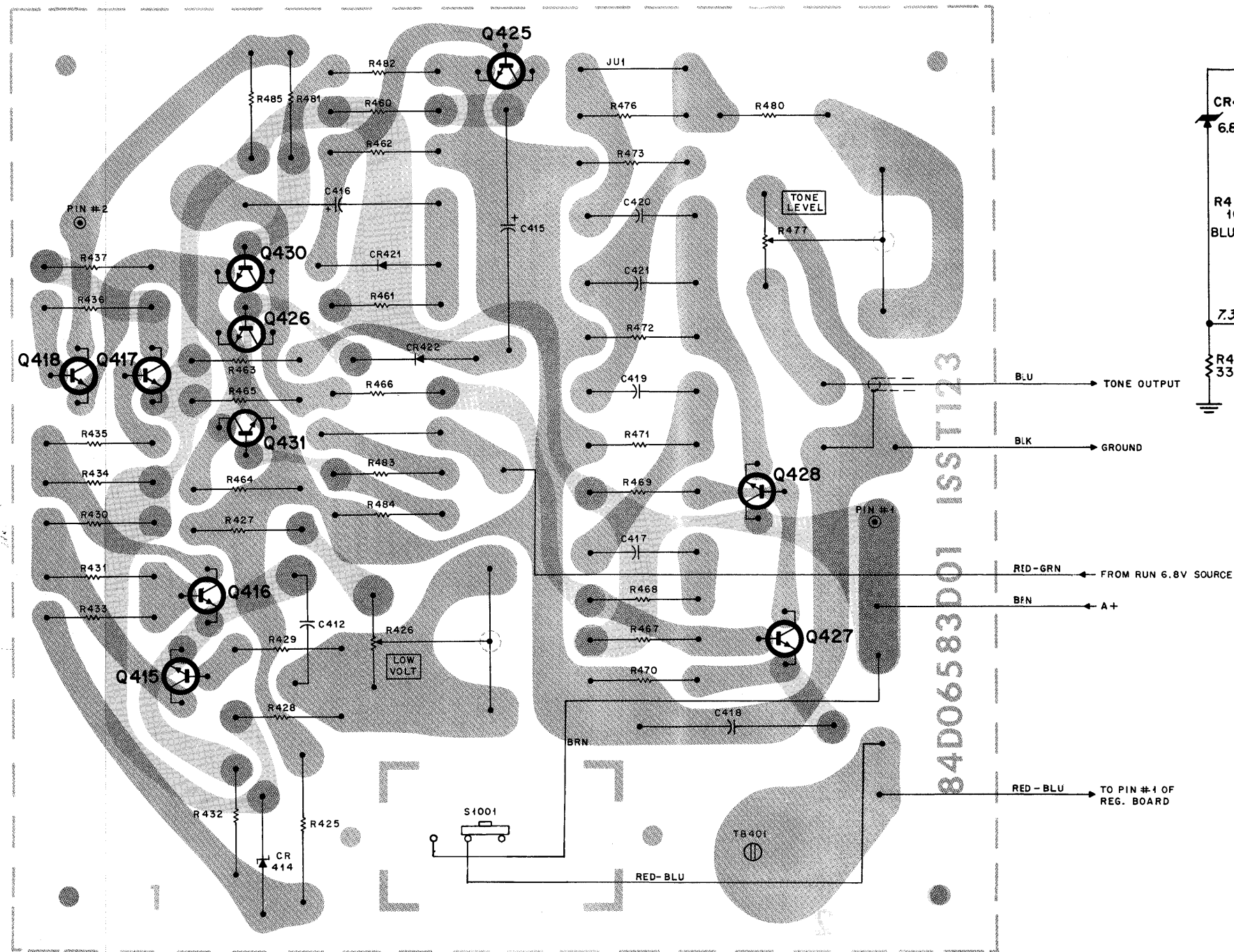

SHOWN FROM SOLDER SIDE

SOLDER COMPONENT OVERLAY
 DEPS-11402-0
 DEPS-11400-A

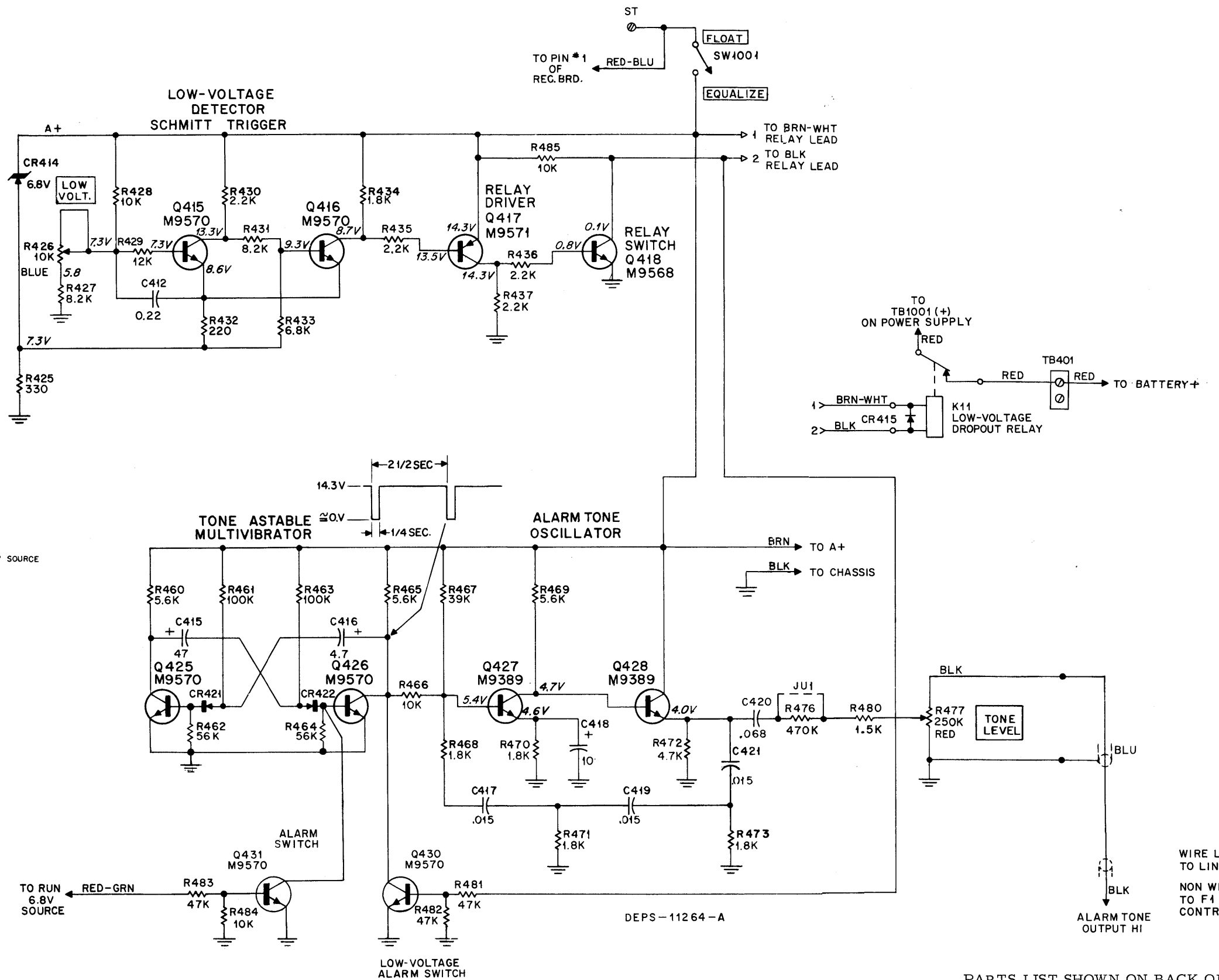

DEPS-11264-A

WIRE LINE CONTROL:
 TO LINE DRIVER PIN #6
 NON WIRE LINE CONTROL:
 TO F1 OR F1-"PL"
 CONTROL MODULE PIN #22

PARTS LIST SHOWN ON BACK OF
 POWER SUPPLY/BATTERY CHARGER
 SCHEMATIC

Battery Protection and Alarm (Option No. C29)
 Schematic Diagram & Circuit Board Detail
 Motorola No. PEPS-12268-A
 11/11/75-UP

84D83256F01

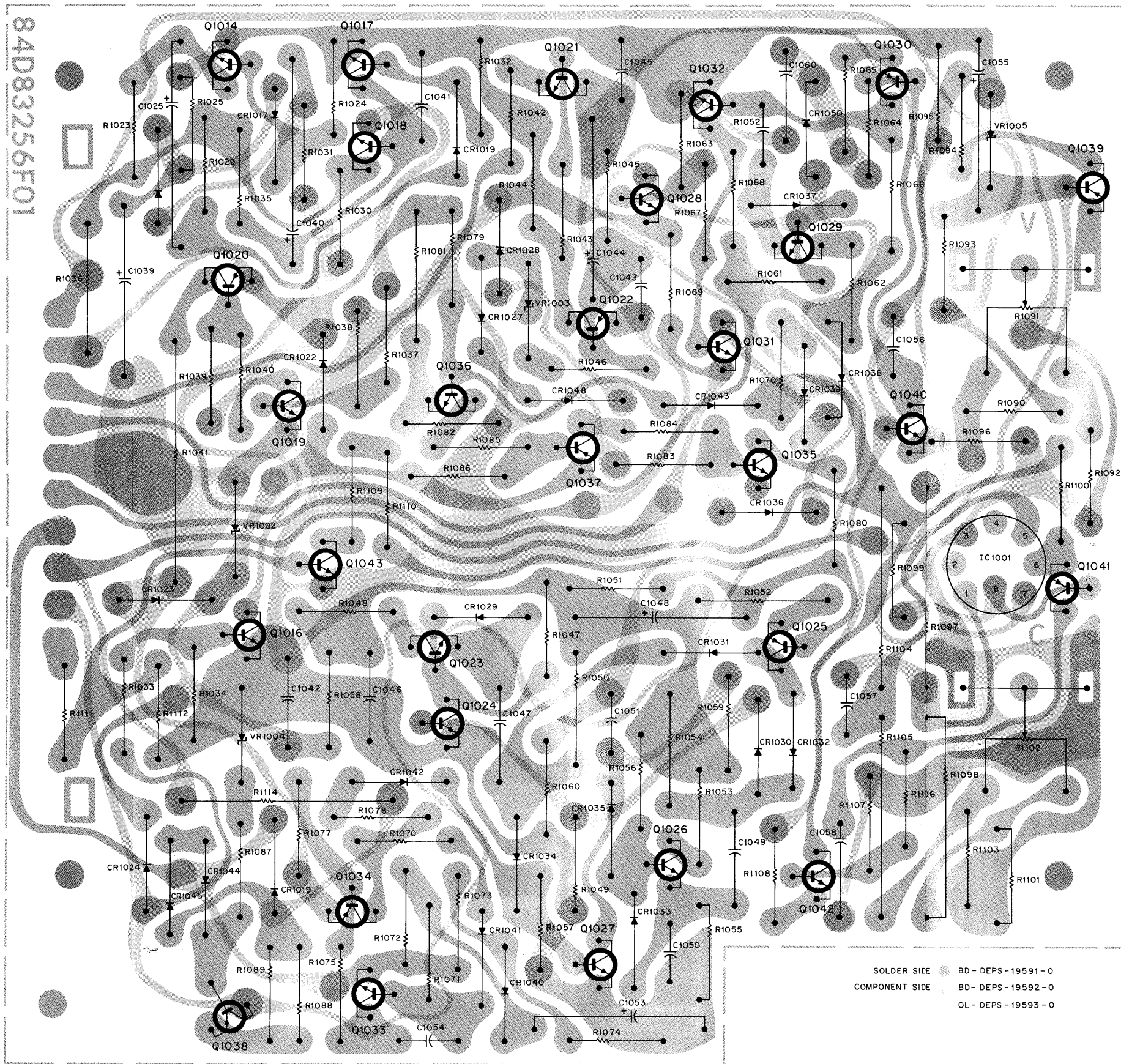

SHOWN FROM SOLDER SIDE

14 V REGULATOR BOARD

TPN1105A & TPN1106A Power Supply/
Battery Charger, Circuit Board Detail
Motorola No. PEPS-19594-O
11/11/75-UP

- NOTES:
- CIRCLED NUMBERS INDICATE LOCATIONS AT WHICH TO OBSERVE WAVEFORMS ON AN OSCILLOSCOPE.
 - VOLTAGES--
 - FL = FULL LOAD (APPROX. 30 AMPS).
 - NL = NO LOAD.
 - VOLTAGES SHOWN IN PARENTHESIS ARE PRESENT DURING THE START ATTEMPT ONLY. ALL OTHERS ARE PRESENT DURING THE RUN CONDITION.
 - VOLTAGES ARE TYPICAL AND DO NOT CHANGE SIGNIFICANTLY FROM LOAD TO NO-LOAD CONDITIONS UNLESS OTHERWISE INDICATED.
 - ALL VOLTAGES ARE MEASURED WITH AN 11 MEGOHM INPUT RESISTANCE VOLTMETER IN RESPECT TO CHASSIS GROUND, UNLESS OTHERWISE STATED, CAPACITOR VALUES ARE IN MICRO-FARADS.
 - UNLESS OTHERWISE STATED, RESISTOR VALUES ARE IN OHMS.
 - 12 VOLT BATTERY TO BE SUPPLIED BY CUSTOMER.
 - R1097, R1098, R1104, & R1105 ARE A THICK-FILM RESISTOR NETWORK.

EPS-10559-O

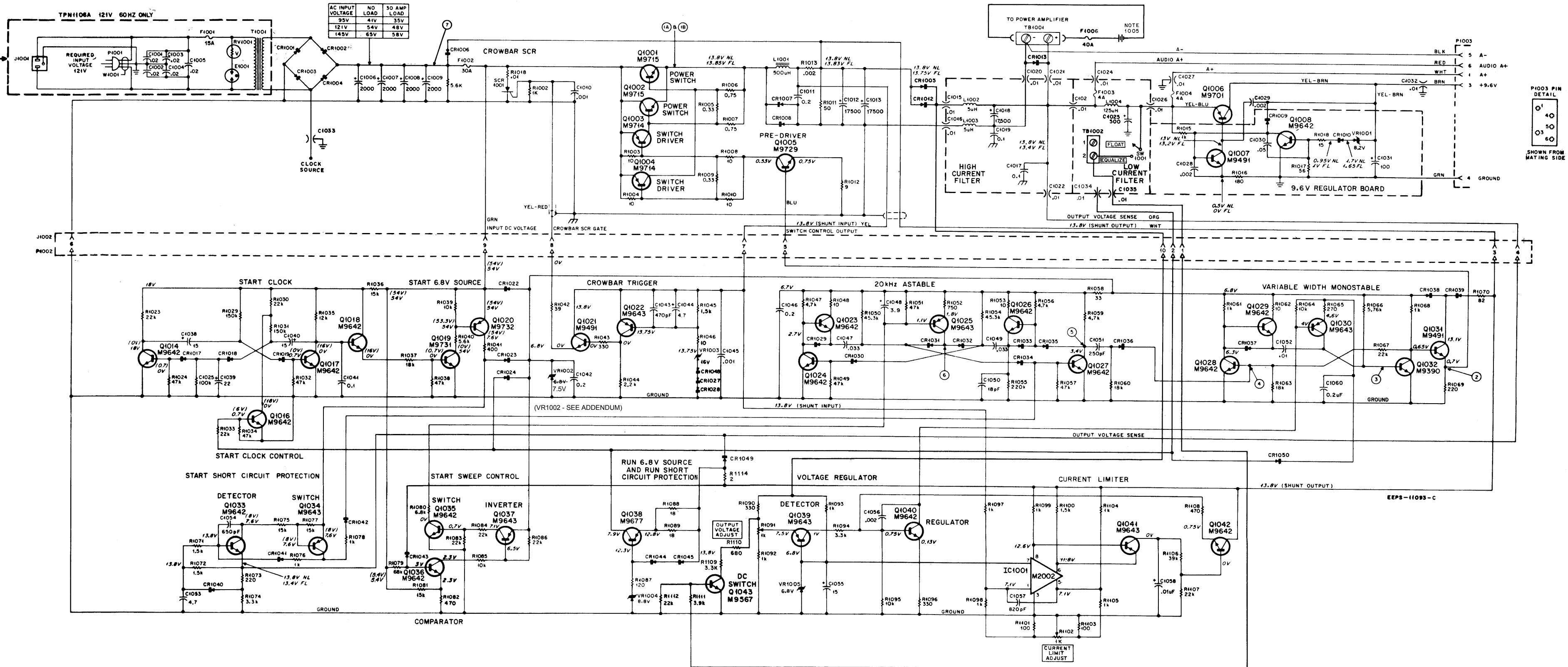
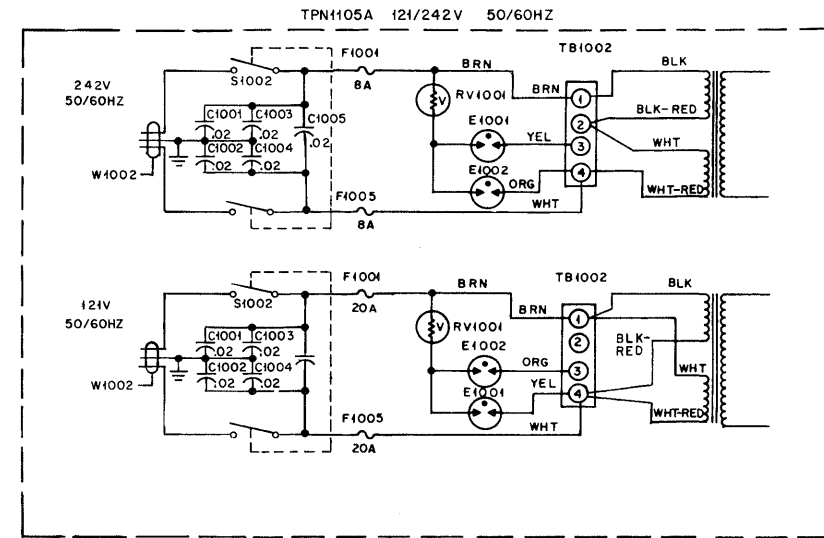

9.6 VOLT REGULATOR BOARD

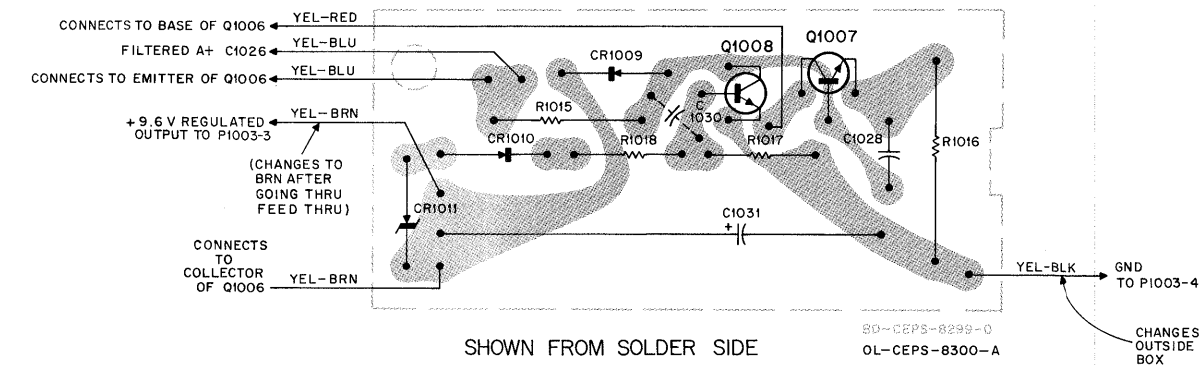
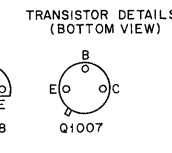

OSCILLOSCOPE WAVEFORMS MEASURED UNDER FOLLOWING CONDITIONS:

- VERTICAL SENSITIVITY AND HORIZONTAL DEFLECTION, AND POWER SUPPLY LOAD CONDITION SHOWN WITH EACH WAVEFORM.
- NOMINAL INPUT VOLTAGE APPLIED (121 V AC).

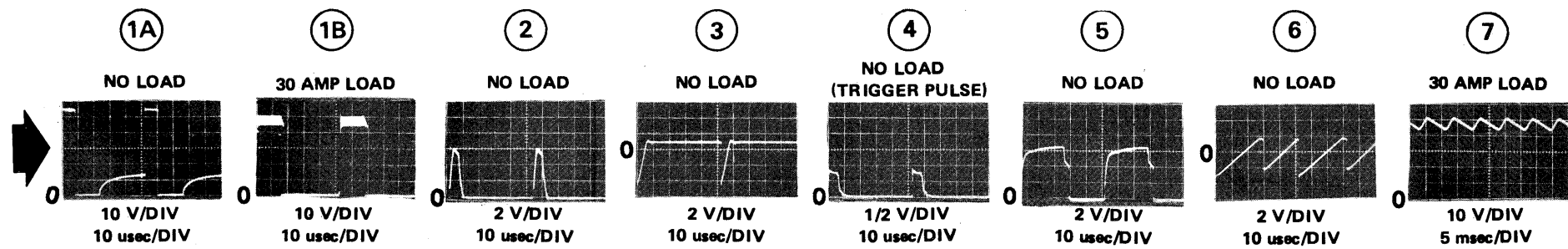

PARTS LIST SHOWN ON BACK OF THIS DIAGRAM
 TPN1105A & TPN1106A Power Supply/Battery Charger Schematic Diagram and 9.6 V Regulator Board Circuit Board Detail
 Motorola No. 63P81104E93-A
 11/11/75-UP

REFERENCE SYMBOL	MOTOROLA PART NO.	DESCRIPTION
------------------	-------------------	-------------

14 V REGULATOR BOARD

PARTS LIST
TLN5299A 14 V Regulator Board
(Part of TPN105A & TPN106A) PL-2280-A

C1038	23-83214C18	CAPACITOR, fixed: μF $\pm 10\%$; 25 V; unl. stated
C1039	23-83214C07	15 $\pm 20\%$; 35 V
C1040	23-83214C18	22 $\pm 20\%$; 15 V
C1041	21-82372C01	15 $\pm 20\%$; 35 V
C1042	21-82372C02	0.1 $\pm 80\%$ -20%; 25 V
C1043	21-82187B07	0.2 $\pm 80\%$ -20%; 25 V
C1044	23-83214C15	4.7 $\pm 20\%$; 25 V
C1045	21-82187B14	18 pF $\pm 5\%$; 500 V
C1046	21-82372C02	0.2 $\pm 80\%$ -20%; 25 V
C1047	8-83813H34	.033 $\pm 5\%$; 100 V
C1048	23-83214C29	39; 10 V
C1049	8-83813H34	.033 $\pm 5\%$; 100 V
C1050	21-82133G77	18 pF $\pm 5\%$; N150
C1051	21-859943	250 pF $\pm 5\%$
C1052	8-83514E06	.01 $\pm 5\%$
C1053	23-83214C15	4.7 $\pm 20\%$; 25 V
C1054	21-82428B23	.0012; 100 V
C1055	23-83214C02	15 $\pm 20\%$; 25 V
C1056	21-82428B25	.002 $\pm 20\%$; 500 V
C1057	21-82187B17	820; 500 V
C1058	8-82905G01	.01; 50 V
C1060	21-82372C02	0.2 $\pm 80\%$ -20%; 25 V
CR1017, 1018, 1019	48-83654H01	silicon
CR1022, 1023, 1024	48-82466H13	silicon
CR1027, 1028, 1029 thru 1042	48-82392B12	silicon
CR1043 thru 1045	48-82392B03	silicon
CR1048, CR1049	48-82392B12	silicon
IC1001	51-84320A02	INTEGRATED CIRCUIT: type M2002
P1002		CONNECTOR, plug: consists of 29-84028H01 male single contact; 8 req'd
Q1014	48-869642	TRANSISTOR; (SEE NOTE)
Q1016, 1017, 1018	48-869642	NPN; type M9642
Q1019	48-869731	NPN; type M9731
Q1020	48-869732	PNP; type M9732
Q1021	48-869491	NPN; type M9491
Q1022	48-869643	PNP; type M9643
Q1023, 1024	48-869642	NPN; type M9642
Q1025	48-869643	PNP; type M9643
Q1026, 1027, 1028, 1029	48-869642	NPN; type M9642
Q1030	48-869643	PNP; type M9643
Q1031	48-869491	NPN; type M9491
Q1032	48-869390	NPN; type M9390
Q1033	48-869642	NPN; type M9642
Q1034	48-869643	PNP; type M9643
Q1035, 1036	48-869642	NPN; type M9642
Q1037	48-869643	PNP; type M9643
Q1038	48-869677	PNP; type M9677
Q1039	48-869643	PNP; type M9643
Q1040	48-869642	NPN; type M9642
Q1041	48-869643	PNP; type M9643
Q1042	48-869642	NPN; type M9642
Q1043	48-869567	NPN; type M9567
R1023	6-128685	RESISTOR, fixed: $\pm 10\%$; 1/4 W; unl. stated
R1024	6-128902	22k
R1025	6-129226	47k
R1029	6-129146	100k
R1030	6-128685	150k
R1031	6-129146	22k
R1032	6-128902	150k
R1033	6-128685	47k
R1034	6-129226	100k
R1035	6-129146	150k
R1036	6-128685	22k
R1037	6-129146	150k
R1038	6-128902	47k
R1039	6-129226	100k
R1040	6-129146	150k
R1041	6-128685	22k
R1042	6-129146	150k
R1043	6-128902	47k
R1044	6-129226	100k
R1045	6-129146	150k
R1046	6-128685	22k
R1047	6-129146	150k
R1048	6-128902	47k
R1049	6-129226	100k
R1050	6-129146	150k
R1051	6-128685	22k
R1052	6-129146	150k
R1053	6-128902	47k
R1054	6-129226	100k
R1055	6-129146	150k
R1056	6-128685	22k
R1057	6-129146	150k
R1058	6-128902	47k
R1059	6-129226	100k
R1060	6-129146	150k
R1061	6-128685	22k
R1062	6-129146	150k
R1063	6-128902	47k
R1064	6-129226	100k
R1065	6-129146	150k
R1066	6-128685	22k
R1067	6-129146	150k
R1068	6-128902	47k
R1069	6-129226	100k
R1070	6-129146	150k
R1071, 1072	6-128685	22k
R1073	6-128902	47k
R1074	6-129226	100k
R1075	6-129146	150k
R1076	6-128685	22k
R1077	6-129146	150k
R1078	6-128902	47k
R1079	6-129226	100k
R1080	6-129146	150k
R1081	6-128685	22k
R1082	6-129146	150k
R1083	6-128902	47k
R1084	6-129226	100k
R1085	6-129146	150k
R1086	6-128685	22k
R1087	6-129146	150k
R1088	6-128902	47k
R1089	6-129226	100k
R1090	6-129146	150k
R1091	6-128685	22k
R1092, 1093	6-129146	150k
R1094	6-128902	47k
R1095	6-129226	100k
R1096	6-129146	150k
R1097, 1098	6-128685	22k
R1099	6-129146	150k
R1100	6-128902	47k
R1101	6-129226	100k
R1102	6-129146	150k
R1103	6-128685	22k
R1104, 1105	6-129146	150k
R1106	6-128902	47k
R1107	6-129226	100k
R1108	6-129146	150k
R1109	6-128685	22k
R1110	6-129146	150k
R1111	6-128902	47k
R1112	6-129226	100k
R1113	6-129146	150k
R1114	6-128685	22k
VR1002, 1005	48-82256C37	SEMICONDUCTOR DEVICE, Zener diode; (SEE NOTE) 6.8 V

REFERENCE SYMBOL	MOTOROLA PART NO.	DESCRIPTION
------------------	-------------------	-------------

R1033	6-128685	22k
R1034	6-128902	47k
R1035	6-129226	100k
R1036	6-129146	150k
R1037	6-128902	47k
R1038	6-129226	100k
R1039	6-129146	150k
R1040	6-128685	22k
R1041	6-129146	150k
R1042	6-128902	47k
R1043	6-129226	100k
R1044	6-129146	150k
R1045	6-128685	22k
R1046	6-129146	150k
R1047	6-128902	47k
R1048	6-129226	100k
R1049	6-129146	150k
R1050	6-128685	22k
R1051	6-129146	150k
R1052	6-128902	47k
R1053	6-129226	100k
R1054	6-129146	150k
R1055	6-128685	22k
R1056	6-129146	150k
R1057	6-128902	47k
R1058	6-129226	100k
R1059	6-129146	150k
R1060	6-128685	22k
R1061	6-129146	150k
R1062	6-128902	47k
R1063	6-129226	100k
R1064	6-129146	150k
R1065	6-128685	22k
R1066	6-129146	150k
R1067	6-128902	47k
R1068	6-129226	100k
R1069	6-129146	150k
R1070	6-128685	22k
R1071, 1072	6-129146	150k
R1073	6-128902	47k
R1074	6-129226	100k
R1075	6-129146	150k
R1076	6-128685	22k
R1077	6-129146	150k
R1078	6-128902	47k
R1079	6-129226	100k
R1080	6-129146	150k
R1081	6-128685	22k
R1082	6-129146	150k
R1083	6-128902	47k
R1084	6-129226	100k
R1085	6-129146	150k
R1086	6-128685	22k
R1087	6-129146	150k
R1088	6-128902	47k
R1089	6-129226	100k
R1090	6-129146	150k
R1091	6-128685	22k
R1092, 1093	6-129146	150k
R1094	6-128902	47k
R1095	6-129226	100k
R1096	6-129146	150k
R1097, 1098	6-128685	22k
R1099	6-129146	150k
R1100	6-128902	47k
R1101	6-129226	100k
R1102	6-129146	150k
R1103	6-128685	22k
R1104, 1105	6-129146	150k
R1106	6-128902	47k
R1107	6-129226	100k
R1108	6-129146	150k
R1109	6-128685	22k
R1110	6-129146	150k
R1111	6-128902	47k
R1112	6-129226	100k
R1113	6-129146	150k
R1114	6-128685	22k
VR1002, 1005	48-82256C37	SEMICONDUCTOR DEVICE, Zener diode; (SEE NOTE) 6.8 V

REFERENCE SYMBOL	MOTOROLA PART NO.	DESCRIPTION
------------------	-------------------	-------------

VR1003	48-83696E12	16 V
VR1004	48-82256C56	8.8 V
NON-REFERENCED ITEMS		
	42-84228B01	RETAINER; 8 req'd.
	5-84500B01	EYELET, special; 4 req'd.
	55-84300B01	HANDLE

REFERENCE SYMBOL	MOTOROLA PART NO.	DESCRIPTION
------------------	-------------------	-------------

POWER SUPPLY CHASSIS

TLN5298A Power Supply Chassis (p/o TPN106A)
TLN5300A Power Supply Chassis (p/o TPN105A) PL-2281-O

C1001 thru 1005	21-83596E16	CAPACITOR, fixed: μF ; 2.02 $\pm 80\%$ -20%; 2000 V
C1006 thru 1009	23-83093G21	.000 $\pm 100\%$ -10%; 100 V
C1010	21-82187B14	.001; 100 V
C1011	21-82372C02	0.2 $\pm 80\%$ -20%; 25 V
C1012, 1013	23-83093G20	17.500 $\pm 150\%$ -10%; 20 V
C1015, 1016	21-84211B01	.01; GMV; 250 V
C1017	8-82317B01	0.1; 100 V
C1018	23-83093G20	17.500 $\pm 150\%$ -10%; 20 V
C1019	8-82317B01	.01; 100 V
C1020 thru 1024	21-84211B01	.01; GMV; 250 V
C1025	23-83210A19	500 $\pm 100\%$ -10%; 20 V
C1026, 1027	21-84211B01	.01; GMV; 250 V
C1032, 1033, 1034, 1035	21-84211B01	.01; GMV; 250 V
CR1001	48-82732C09	silicon
CR1002	48-82732C08	silicon
CR1003	48-82732C09	silicon
CR1004, 1005	48-82732C09	silicon
CR1006	48-82732C08	silicon
CR1007	48-82732C13	silicon; type (MR891R)
CR1008	48-82732C13	silicon; type (MR891R)
CR1012	48-82732C09	silicon
CR1013	48-82525G13	silicon
E1001	80-84660D01	spark gap
E1002	80-84660D02	spark gap (TLN5300A only)
F1001	65-139131	FUSE; 15 amp (TLN5298A & TLN5300A 121 V input only)
F1002	65-41492	8 amp (TLN5300A, 242 V input only)
F1003, 1004	65-61688	4 amp
F1005	65-135212	8 amp (TLN5300A, 242 V input only)
J1001	9-83238C01	CONNECTOR, receptacle: female; 3 contact
J1002	1-80728B54	includes; 84-84590A01 Circuit board, 9-83011H01 female; single contact, 8 req'd.
L1001	25-84458D01	COIL: choke, 500 μH
L1002	24-84407E01	choke, 5 μH
L1003	24-84408E01	choke, 5 μH
L1004	24-82606B01	choke, 125 μH
P1001	</	

parts list

TLN5299A 14 V Regulator Board (Part of TPN1105A & TPN1106A) PL-2280-B

REFERENCE SYMBOL	MOTOROLA PART NO.	DESCRIPTION
		capacitor, fixed: uF ± 10%; 25 V: unless otherwise stated
C1038	23-83214C18	15 ± 20%; 35 V
C1039	23-83214C07	22 ± 20%; 15 V
C1040	23-83214C18	15 ± 20%; 35 V
C1041	21-82372C01	.01 + 80-20%; 25 V
C1042	21-82372C02	0.2 + 80-20%; 25 V
C1043	21-82187B07	470 pF; 500 V
C1044	23-83214C15	4.7 ± 20%; 25 V
C1045	21-82187B14	.001; 100 V
C1046	21-82372C02	0.2 + 80-20%; 25 V
C1047	8-83813H34	.033 ± 5%; 100 V
C1048	23-83214C29	39; 10 V
C1049	8-83813H34	.033 ± 5%; 100 V
C1050	21-82133G77	18 pF ± 5%; N150
C1051	21-859943	250 pF ± 5%
C1052	8-83514E06	.01 ± 5%
C1053	23-83214C15	4.7 ± 20%; 25 V
C1054	21-82428B23	.0012; 100 V
C1055	23-83214C02	15 ± 20%; 25 V
C1056	21-82428B25	.002 ± 20%; 500 V
C1057	21-82187B17	820; 500 V
C1058	8-82905G01	.01; 50 V
C1060	21-82372C02	0.2 + 80-20%; 25 V
		semiconductor device:
		diode: (see note)
CR1017, 1018, 1019	48-83654H01	silicon
CR1022, 1023, 1024	48-82466H13	silicon
CR1027, 1028	48-82392B11	silicon
CR1029 thru 1042	48-83654H01	silicon
CR1043 thru 1045	48-82392B03	silicon
CR1048	48-82392B12	silicon
CR1049	48-82466H13	silicon
		integrated circuit:
IC1001	51-84320A02	type M2002
		connector, plug:
P1002		consists of 29-84028H01 male single contact; 8 req'd.
		transistor: (see note)
Q1014	48-869642	NPN; type M9642
Q1016, 1017, 1018	48-869642	NPN; type M9642
Q1019	48-869731	NPN; type M9731
Q1020	48-869732	PNP; type M9732
Q1021	48-869491	NPN; type M9491
Q1022	48-869643	PNP; type M9643
Q1023, 1024	48-869642	NPN; type M9642
Q1025	48-869643	PNP; type M9643
Q1026, 1027, 1028, 1029	48-869642	NPN; type M9642
Q1030	48-869643	PNP; type M9643
Q1031	48-869491	NPN; type M9491
Q1032	48-869390	NPN; type M9390
Q1033	48-869642	NPN; type M9642
Q1034	48-869643	PNP; type M9643
Q1035, 1036	48-869642	NPN; type M9642
Q1037	48-869643	PNP; type M9643
Q1038	48-869677	PNP; type M9677
Q1039	48-869643	PNP; type M9643
Q1040	48-869642	NPN; type M9642
Q1041	48-869643	PNP; type M9643
Q1042	48-869642	NPN; type M9642
Q1043	48-869667	NPN; type M9657
		resistor, fixed: ± 10%; 1/4 W: unless otherwise stated
R1023	6-128685	22k
R1024	6-128902	47k
R1025	6-129226	100k
R1029	6-129146	150k
R1030	6-128685	22k
R1031	6-129146	150k
R1032	6-128902	47k
R1033	6-128685	22k
R1034	6-128902	47k
R1035	6-129230	12k
R1036	6-6477	15k
R1037	6-128904	18k
R1038	6-128902	47k
R1039	6-129225	10k
R1040	6-129433	5.6k
R1041	17-82177B31	400; 5 W
R1042	6-131652	39
R1043	6-129775	330
R1044	6-128689	2.2k
R1045	6-129681	1.5k ± 5%
R1046	6-124A01	10 ± 5%
R1047	6-127804	4.7k
R1048	6-129775	10
R1049	6-128902	47k

REFERENCE SYMBOL	MOTOROLA PART NO.	DESCRIPTION
R1050	6-83175C56	45.3k; 1%
R1051	6-128902	47k
R1052	6-84444A18	750; 1%
R1053	6-129775	10
R1054	6-83175C56	45.3; 1%
R1055	6-129147	220k
R1056	6-127804	4.7k
R1057	6-128902	47k
R1058	6-129754	33
R1059	6-127804	4.7k
R1060	6-128904	18k
R1061	6-127802	1k
R1062	6-129755	10
R1063	6-128904	18k
R1064	6-129225	10k
R1065	6-131525	270 ± 5%
R1066	6-83175C85	5.76 ± 1%
R1067	6-128685	22k
R1068	6-127802	1k
R1069	6-127800	220
R1070	6-129224	82
R1071, 1072	6-127803	1.5k
R1073	6-127800	220
R1074	6-129231	3.3k
R1075	6-127805	15k
R1076	6-127802	1k
R1077	6-127805	15k
R1078	6-127802	1k
R1079	6-129144	68k
R1080	6-128687	6.8k
R1081	6-5726	15k ± 5%; 1/2 W
R1082	6-129709	470 ± 5%
R1083	6-128685	22k
R1084	6-128685	22k
R1085	6-129225	10k
R1086	6-128685	22k
R1087	6-129617	120
R1088, 1089	6-124A07	18 ± 5%
R1090	6-124C37	330
R1091	18-83083G14	var: 1k
R1092, 1093	6-127802	1k
R1094	6-129231	3.3k
R1095	6-129225	10k
R1096	6-129806	330 ± 5%
R1097, 1098	51-84312B83	module, 1k (also R1104 & R1105)
R1099	6-127802	1k
R1100	6-127803	1.5k
R1101	6-129753	100
R1102	18-83083G14	var: 1k
R1103	6-129753	100
R1104, 1105	51-84312B83	module, 1k (also R1097 & R1098)
R1106	6-128903	39k
R1107	6-128685	22k
R1108	6-127801	470
R1109	6-129981	680 ± 5%
R1110	6-129984	3.3k ± 5%
R1111	6-129232	3.9k
R1112	6-128685	22k
R1113		NOT USED
R1114	17-82036G03	2 ± 5%; 2 W
		semiconductor device:
		Zener diode: (see note)
VR1002	48-82256C68	7.5 V
VR1003	48-83696E12	16 V
VR1004	48-82256C56	8.8 V
VR1005	48-82256C68	7.5 V
		non-referenced items
	42-84228B01	RETAINER, 8 req'd.
	5-84500B01	EYELET, special; 4 req'd.
	55-84300B01	HANDLE

TLN5298A Power Supply Chassis (p/o TPN1106A) PL-2281-A
TLN5300A Power Supply Chassis (p/o TPN1105A)

REFERENCE SYMBOL	MOTOROLA PART NO.	DESCRIPTION
C1001 thru 1005	21-83596E16	capacitor, fixed; uF: .02 + 80-20%; 2000 V
C1006 thru 1009	23-83093G21	2000 + 100-10%; 100 V
C1010	21-82187B14	.001; 100 V
C1011	21-82372C02	0.2 + 80-20%; 25 V
C1012, 1013	23-83093G20	17,500 + 150-10%; 20 V
C1015, 1016	21-84211B01	.01; GMV; 250 V
C1017	8-82317B01	0.1; 100 V
C1018	23-83093G20	17,500 + 150-10%; 20 V
C1019	8-82317B01	.01; 100 V
C1020 thru 1024	21-84211B01	.01; GMV; 250 V
C1025	23-83210A19	500 + 100-10%; 20 V
C1026, 1027	21-84211B01	.01; GMV; 250 V
C1032 thru 1035	21-84211B01	.01; GMV; 250 V
		semiconductor device:
		diode: (see note)
CR1001	48-82732C09	silicon
CR1002	48-82732C08	silicon
CR1003	48-82732C09	silicon
CR1004, 1005	48-82732C09	silicon
CR1006	48-82732C08	silicon
CR1007, 1008	48-82732C13	silicon; type (MR891R)
CR1012	48-82732C09	silicon
CR1013	48-82525G13	silicon
		surge voltage protection:
E1001	80-84660D01	spark gap
E1002	80-84660D02	spark gap (TLN5300A only)
		fuse:
F1001	65-139131	15 amp (TLN5298A & TLN5300A 121 V input only)
		or 65-135212
F1002	65-41492	30 amp
F1003, 1004	65-61688	4 amp
F1005	65-135212	8 amp (TLN5300A, 242 V input only)
		or 65-135013
		connector, receptacle:
J1001	9-83238C01	female; 3-contact
J1002	1-80728B54	includes: 84-84590A01 circuit board, 9-83011H01 female; single contact; 8 req'd.
		coil:
L1001	25-84458D01	choke, 500 uH
L1002	24-84407E01	choke, 5 uH
L1003	24-84408E01	choke, 5 uH
L1004	24-82606B01	choke, 125 uH
		connector, plug:
P1001		Part of W1001
		transistor: (see note)
Q1001, 1002	48-869715	NPN; type M9715
Q1003, 1004	48-869714	PNP; type M9714
Q1005	48-869729	NPN; type M9729
		resistor, fixed: ± 10%; 1/2 W: unless otherwise stated
R1001	6-5765	5.6k; 2 W
R1002	6-127802	1k; 1/4 W
R1003, 1004	6-5621	10
R1005	17-890467	0.33
R1006, 1007	17-82036913	0.75 ± 5%; 2 W
R1008	6-488033	10; 2 W
R1009	17-890467	0.33
R1010	6-488033	10; 2 W
R1011	17-82177B20	50; 10 W
R1012	17-85492	9 ± 5%
R1013	6-84449D02	.002
R1018	6-84232B02	shunt, resistor
		varistor:
RV1001	6-84661D01	transient voltage suppressor
		switch, toggle:
S1002	40-82878D02	spdt
		semiconductor device:
		diode: (see note)
SCR1001	48-84973C01	silicon controlled diode
		transformer:
T1001	25-84455D02 (TLN5298A) or 25-84455D03 (TLN5300A)	Pri: BLK, BLK; res. 0.20 ohm Sec: RED, RED; res. 0.24 ohm Pri: BLK, BLK-RED; res. 0.305 ohm; WHT, WHT-RED res. 0.546 ohm Sec: RED-RED; res. 0.030 ohm
		cable:
W1001	30-83211C01	AC line cord; includes refer P1001
		fuseholder:
XF1001	9-82083C01	panel mounting terminal
XF1002	31-84599D01	terminal

REFERENCE SYMBOL	MOTOROLA PART NO.	DESCRIPTION
XF1003, 1004	9-82083C01	panel mounting
XF1005	9-82083C01	panel mounting (TLN5300A only)
		non-referenced items
	43-84408D01	SPACER, 2 req'd.
	26-84335D01	SHIELD, choke; L1001
	15-84334D01	COVER, choke; L1001
	42-82018H01	RETAINER, line cord
	64-84340D02	PLATE, cover pwr
	37-109120	GROMMET, rubber; 2 req'd.
	26-84470D01	HEAT EXCHANGER
	4-82345A11	WASHER, shoulder
	3-122309	LOCKSCREW; (8-32 x 3/8) plain hex, 7 req'd.
	14-83575A01	INSULATOR, mica; 3 req'd.
	42-82387D08	CLAMP, 7/16"
	7-83959A01	HEAT SINK
	9-83662A01	SOCKET, transistor; Q1003, 1004, 1005
	14-84037C01	SOCKET, capacitor; C1006, 1007, 1008, 1009, 1012, 1013
		semiconductor device:
		diode:
CR414	48-82256C02	Zener, 6.8 V
CR421, 422	48-82392B03	silicon
		transistor:
Q415, 416	48-869570	NPN; type M9570
Q417	48-869571	PNP; type M9571
Q418	48-869568	NPN; type M9568
Q425, 426	48-869570	NPN; type M9570
Q427, 428	48-869389	NPN; type M9389
Q430, 431	48-869570	NPN; type M9570
		resistor, fixed: ± 10%; 1/4 W: unless otherwise stated
R425	6-2096	330 1/2 W
R426	18-83083G17	variable; 10k ± 20%; (BLUE)
R427	6-129983	8.2k; 5%
R428	6-129225	10k
R429	6-129230	12k
R430	6-128689	2.2k
R431	6-129983	8.2k; 5%
R432	6-	