

ELECTROMAGNETIC DESIGNS AND CONSULTING SERVICES
FOR THE TWO-WAY COMMUNICATIONS INDUSTRY
22402 N. 19th Avenue - Phoenix, Arizona 85027
Toll Free: 1-800-796-2875 Tel: (623) 581-2875
Fax: (623) 582-9499 e-mail: info@emrcorp.com

RECEIVER MULTICOUPLER AND R.F. PRESELECTORS

General

The EMR corporation series of receiver multicouplers include a basic chassis on which a high performance, low noise amplifier and its power supply are mounted. A preselector is placed between the receiving antenna and the amplifier input according to the band of operation desired. The amplifier feeds a system of signal power dividers. A wide selection of preselectors, amplifiers and dividers provide multicoupler models meeting requirements of all radio site applications. Standard and custom models include:

- Operation in all popular land mobile radio bands from 30 through 960 MHz.
- Operation of from two to sixty-four receivers from a suitable antenna.
- Operation from a variety of power sources, including 117 volts or 230 volts, 50 -60 Hz., 12, 24, or 48 volts D.C., positive or negative grounded.
- Preselector passbands from as narrow as 0.5 MHz. to more than 20 MHz. according to specific site equipment requirements.
- "Tower Topper" models, having the preselector and amplifier mounted at antenna level of the tower, providing improved noise figure in system receiving, overcoming the loss in long transmission lines and other benefits.

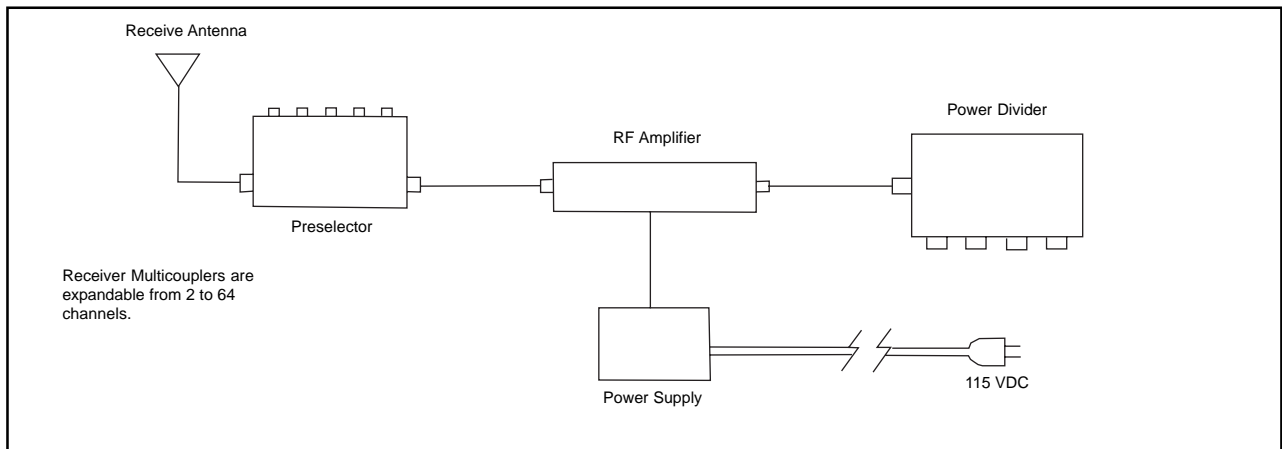

Figure 1. Block diagram of a standard Receiver Multicoupler

Operating Theory

Figure 1 shows a block diagram of the layout of a basic receiver multicoupler system. The transmission line from the system receiving antenna connects to the input of the preselector. Preselector output is routed to a high performance amplifier, the output of which feeds the signal power divider. A high quality regulated and filtered power supply, inverter and converter supplies operating power for the amplifier.

Characteristics of each of the components of the multicoupler are as follows:

Preselector

The preselector is basically a bandpass filter. Its purpose is to pass the desired range of frequencies of the receivers to be employed with as near a flat response as possible and as low an insertion loss as possible. At the same time, rejection of all other frequencies is provided.

EMR corporation preselectors vary from single or dual cavity resonator combinations to multi-stage inductive, aperture coupled or comb filters. Special preselector assemblies may include one or more of these devices in combination, multiple pass and stop band characteristics, special notch elements, etc. according to the complexity of site requirements. EMR preselectors are designed with optimization of losses, selectivity and costs with respect to the particular site requirements.

All EMR Corporation preselectors are custom tuned and optimized using swept signal analysis techniques. They are in general very frequency stable over wide ranges of temperature, humidity, vibration and other environment conditions.

Amplifiers

The amplifiers used are of the highest quality and dependability to be found in the land mobile equipment market. Standard land mobile system amplifiers for the 30 - 50, 72 - 76, 132 - 174, 406 - 512 and 800 through 960 MHz. ranges have gains of from 15 to 26 dB, noise figures from 1.8 to 3.5 dB, 3rd order intercept rating of up to +38 dBm and 1dB compression points of up to +26 dBm. The choice of amplifier to be used in a given multicoupler is determined by frequency band, bandwidth, nature of the installed location and other relative factors. Most amplifiers are optimized for best noise figure and linearity at a fixed gain. Coaxial T-Pads are used to attenuate excess gain according to number of power division splits and other considerations.

Power Dividers

The power dividers split the amplifier output power into discrete matched impedance receiver feeds. The hybrid designs used in the power dividing process also provides 25 dB or more of isolation between all receivers fed by common multicoupler. Each time that the signal power is split, 3 dB of loss results plus connector and internal line losses of 0.1 to 0.2 dB.

Splitting and dividing losses are generally as follows:

No. of Outputs	No. of Splits	Insertion Loss
2	1	3.2 dB max
4	2	6.4 dB max.
8	3	9.6 dB max.
16	4	12.9 dB max.
32	5	16.1 dB max.
64	6	19.5 dB max.

Dividers for 6, 10, 12 and 36 feeds are also available. Their insertion loss is the same as the next higher number in the table above. Unused ports of any power divider must be terminated by a matching 50 ohm load to maintain balance throughout the divider "chain". Essentially, power dividers are hybrids employing Wilkinson Splitter or equivalent discrete component circuitry. Various combinations of splitters may be employed according to the total number of receivers to be fed and the physical site requirements in terms of cabling, rack position, etc. For example, if up to eight receivers is to be the maximum number used, a single eight-way divider would be mounted directly on the main amplifier chassis to provide the smallest rack space usage. Where 16 channels or more are involved, a two-way divider is mounted on the main chassis and eight-way dividers are mounted central to banks of receivers to reduce the total number of cable runs and cable lengths.

This allows a single cable to feed groups of four, eight or twelve receivers according to their locations at the site. For example, a four-way divider mounted on the main chassis may feed four eight-way dividers mounted on sub-panels near their respective receivers. This approach saves long multiple cable runs and considerable costs in cabling. It also minimizes undesirable cable signal and noise coupling.

All power dividers are supplied with BNC (female) connectors as standard. Type N or UHF connectors are available on special order. The use of UHF (PL-258, SO-239) connectors is not recommended since UHF Connectors are not a constant impedance devices at frequencies above 30 MHz. All receiver feed cables should be high quality double shielded or solid outer conductor type. EMR recommends flexible double shielded cable such as RG223/U or solid copper outer conductor "Superflex". Properly terminated crimp or clamp type male connectors should be used and inter-type adaptors should be avoided wherever possible.

Power Supplies

The following standard EMR receive multicoupler power supplies are available:

Model	Description	Power Source	Output
02001	Standard	115 VAC @ 60 Hz.	13.6 VDC @ 0.3 A.
02002	European	115/230 VAC @ 50-60 Hz.	13.6 VDC @ 0.8 A.
02003	Battery Powered	12 VDC	13.6 VDC @ 0.6 A.
02004	Battery Powered	24 VDC	13.6 VDC @ 0.6 A.
02005	Battery Powered	48 VDC	13.6 VDC @ 0.6 A.
02006	Variable, Hi-Pwr.	115/230 Vac @ 50-60 Hz.	13.6 VDC @ 0.3 A.

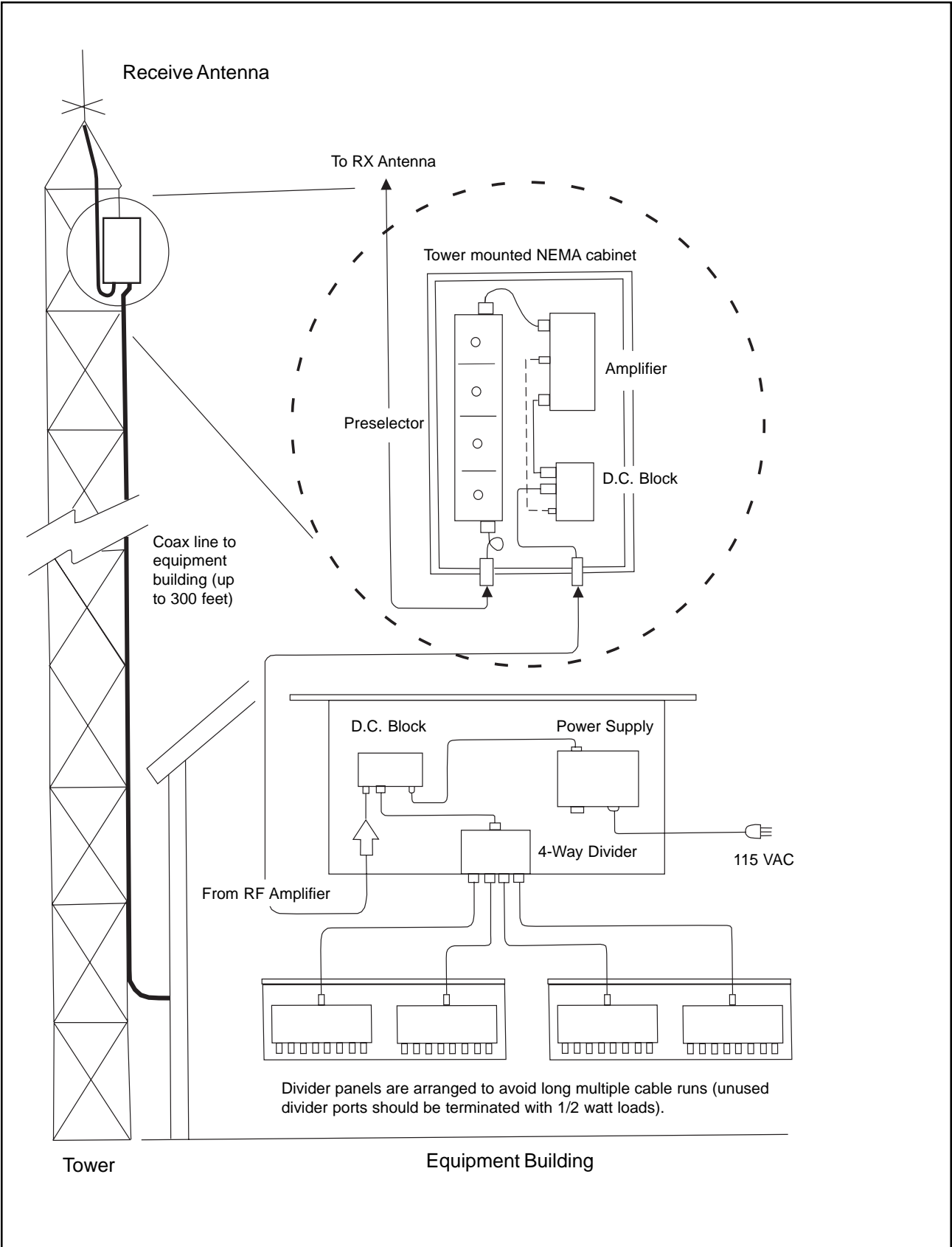

Figure 2, Diagram of a "Tower Topper" Receive Multicoupling System

All battery models use a self-regulating inverter for full 20 VDC output where maximum amplifier performance is required and may be operated from either positive ground battery banks.

Special power supply designs are available including non-interruptable power sources operating from AC power with gelatin cells or nickel-cadmium batteries. These devices operate with an automatic float charging circuit and will deliver up to 8 hours of multicoupler operation after AC line failure.

EMR "Tower Topper" Receive Multicoupler

On-site tests of EMR Corporation "Tower Topper" multicoupler systems have verified improvements in receiver performance from as much as 4 dB to as much as 9 dB in measured effective sensitivity, and a dramatic improvement in range as compared to a multicoupler of identical characteristics ground mounted in traditional applications. In general, the longer the feed line, the more dramatic the improvement in performance.

Several factors contribute to this measurable improvement: (1) The preservation of effective noise figure that is otherwise reduced dB for dB by line loss. (2) As the amplification is all in the tower top amplifier, the level of signals conducted down the transmission line is from 16 to 26 dB higher than any signal or noise responses coupled to the line. (3) More accurate overall matching is maintained between the antenna and first stage amplifier, thus establishing best noise figure for the entire system.

The EMR Corporation "Tower Topper" series of receiver multicouplers were designed specifically for multiple land mobile fixed receivers that are operated at high density remote communications sites. Through use of low loss, steep skirt response, band pass preselector filters and high performance amplifiers located as close as possible to the system receive antenna, the best possible balance between receiver noise figure and signal amplification is enjoyed. Sufficient amplifier gain is provided to overcome transmission line and splitting losses to yield exceptional performance of from two to sixty four receivers per multicoupler system.

Standard models are available for receivers operating in the 132-174, 406-512 and 806-960 MHz bands, and units for the 30-50, 66-88 MHz and other bands are available on special order. Models serving any two of the standard bands using dual preselector/amplifier sections with cross-band couplers (to minimize transmission line costs) are also available.

The tower top unit is assembled in an all weather heavy gauge steel NEMA type enclosure with rubber gasketed access door. This cabinet houses the preselector, amplifier and a D.C. line tap. High quality coax cable connects to gasketed N type bulkhead connectors mounted in the bottom of the enclosure which in turn connect to the receive antenna and the coaxial "downline". The NEMA cabinet is typically held to the tower leg by heavy duty "U" bolts supplied by EMR to suit tower leg or other mounting arrangements.

The preselector/filters feature grounded loop input and output resonator sections for lightning spike protection. Through critical coupling between resonator stages a passband having less than 0.5 dB ripple is defined over the desired receiving frequency range. A relatively steep response is provided to discriminate against out-of-band transmitter signal and noise. In some cases trap elements are provided to reject certain known frequencies, such as the paired transmitter frequencies associated with fixed relay receivers. Passband of from 1 to more than 15 MHz., according to operating band, with skirt slopes falling off at from 5 to 20 dB per MHz. above and below the desired passband range are available.

The D.C. line tap, or D.C. Block, is a device that permits carrying the amplifier supply voltage up the coaxial line with capacitive R.F. coupling and accurate impedances matching. Through the use of MOV's (Metal Oxide Varistors), special Zener diodes and other components, the line taps provide protection to the amplifier and other components from damage due to lightning strike and also filter out other spike and noise interferences.

In the equipment building, another D.C. line tap, the amplifier-power supply and divider panels, as required, are mounted on standard relay rack chassis. Power dividers are located in such a way as to minimize multiple cable runs. Unused power divider ports should always be terminated with 1/2 watt 50 Ohm loads (EMR model 1605) to maintain balance between divider sections. The power dividers provide 25 dB of isolation between receiver feed ports for protection against receiver injection frequency leakage or possible intermodulation products generated in receiver input stages under high signal level conditions.

General Operation

The following points are of interest in the general operation of EMR Corporation Receiver Multicouplers:

Adjustments

Generally, no adjustment to any of the components of the multicoupler are required at the time of installation nor should any be attempted. Preselector pass and reject response is set to it's optimum at the factory using wave analysis techniques. Amplifier gain is fixed and, where required, padded to optimize performance in terms of system noise figure, overall gain, etc. for best available receiver performances.

Antenna System

The antenna used to feed the multicoupler must have sufficient bandwidth for the range of frequencies involved. The receive antenna should also have sufficient physical displacement from all transmitting antennas to prevent amplifier overload or coupling of wide-band transmitter noise into the multicoupler passband range. At least 50 dB and preferably 65 dB or more of isolation between the receiving and ANY transmit antenna should be present. With certain frequency combinations even greater antenna isolations may be required. When using a duplexer, isolations of 65 dB or more are required to reject transmitter carrier power and wide-band noise within receiver passband where receivers and transmitters operate on a common antenna. Similar dynamics of isolation apply to receivers and transmitters in multiplex applications.

Cabling

Receiving antenna feedline should be routed separate from transmit feedlines. The lines should be as far away as possible from each other; on opposite tower legs, exiting the equipment building from different places, etc. No coaxial cable provides infinite outer conductor shielding and any mismatch of antenna and line will result in outer conductor standing waves and signal radiation.

Unused Ports

As stated previously, any unused power divider port should be terminated with a resistive load so that the best balance is maintained in gain levels between all receivers. EMR Corporation supplies model 1605 1/2 watt, 50 Ohm, BNC load terminations for this purpose.

Expansion

Most EMR multicouplers can be expanded to feed additional receivers. Up to a total of 64 receivers with frequencies falling within the preselector pass-band may be included with the addition of power divider sub-panels, the removal or replacement of existing pads and the possible change-over of amplifier and power supply. Contact EMR for assistance in ordering multicoupler expansion kits.

Interference Analysis

If interference to any receiver is experienced, any port of the divider system can be used as a “window” for spectrum analysis. A spectrum analyzer can be used to identify the source of interference, eg: excessive undesired transmitter carrier or noise coupling, intermodulation response attributable to two or more transmitters or on-channel interference from other nearby sites. EMR Corporation is pleased to help in identifying the cause and the methods of elimination of interference.

Operating Spares

All receivers in a system are dependent on the common elements of the multicoupler. While it is often impractical to maintain on-site spares of expensive radio system components, it is often advisable to keep on-site spares of the more delicate, yet vital links in the system chain. Specifically, in a multicoupling system, the amplifier and power supply are most susceptible to unexpected and unavoidable damage. EMR has designed as many safeguards as possible into our multicoupling systems and we have experienced very few system failures. Those we have seen are usually due to lightning strike or remote line surge. We therefore strongly recommend that at least an amplifier and a power supply be held on-site as spares. This relatively small investment helps insure a quick repair and a short down time for your system should unexpected failure occur.

REV	EO-DESCRIPTION	DATE	INIT
A	Production Release	01/16/26	PJA

1.00 Electrical Specifications:

- 1.11 Frequency Band: 50-1000 MHz
- 1.12 Gain (dB Typ.): 43 @ 50 MHz, 40 @ 500 MHz, 36 @ 1000 MHz
- 1.13 Input Power (dBm Max. 5 minutes): 30⁴
- 1.14 Output Power (dBm Max.): 12¹
- 1.15 Noise Figure (dB Max.): 1.5⁴
- 1.16 Input P1dB (dBm Typ. w/o Limiter¹): 29 @ 50 MHz, 30 @ 500 MHz, 30 @ 1000 MHz
- 1.17 Output IP3 (dBm Typ. w/o Limiter¹): 50 @ 50 MHz, 49 @ 500 MHz, 46 @ 1000 MHz
- 1.18 Attenuation Control: 0 to 62 dB in 1 dB Increments
- 1.19 VSWR I/O (Max.): 1.7 / 1.5
- 1.20 Full By-Pass Insertion Loss (dB Max.)²:
 - 1.1 (50 to 512 MHz), 2.0 (512 to 1000 MHz)
- 1.21 Full By-Pass VSWR I/O (Max.): 1.5 / 1.5²
- 1.22 Operating Voltage: 13 to 26 VDC
- 1.23 Current Draw (mA Max./Typ.): 600 / 580
- 1.24 Connectors RF/DC Supp: BNC(F)³ / RCA

¹ Input limiters protect amplifier stages from overdrive.

Output limiters protect receivers from overdrive.

² Auto by-pass of malfunctioning amp. stages will also by-pass the associated attenuator, rendering that stage to unity gain less insertion loss. Full by-pass mode engages at amplifier DC power loss or both amplifier stages malfunctioning.

³ N(F) Connectors are optional.

⁴ Input power exceeding -10 dBm will have increased noise figure proportional to input limiter activation. Sustained power input above +15 dBm may cause permanent damage.

2.0 Mechanical Specifications:

- 2.1 Height: 1.12" (28.5 mm)
- 2.2 Width: 6.00" (152.4 mm)
- 2.3 Depth: 3.50" (88.9 mm)
- 2.4 Weight: 1.2 lb (0.54 kg)
- 2.5 Finish: Black Powder Coat

3.0 Environmental Specifications:

- 3.1 Operating Temperature: -30 to +60° c
- 3.2 Storage Temperature: -40 to +100° c
- 3.3 Humidity: 90% (Non condensing)⁴

⁴ Unit must be in operation with power applied.

ALL SPECIFICATIONS ARE SUBJECT TO CHANGE WITHOUT NOTICE.

Total Attenuation is the value of ATTN1 DIP plus the value of ATTN2 DIP. For example, if ATTN1 DIP has switches 1, 2, 3 on then ATTN1 is 1+2+4 = 7 dB, and if ATTN2 DIP has switch 4 on then ATTN2 is 8 dB; the total attenuation will be 7 dB + 8 dB = 15 dB. For optimal performance ATTN1 and ATTN2 settings should be as equal as possible. So, if one wants 3 dB attenuation, it is better to set ATTN1 to 1 dB and ATTN2 to 2 dB rather than just putting ATTN1 to 3 dB.

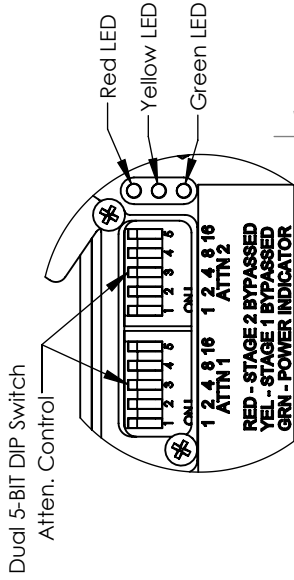

DETAIL A
SCALE 1:1

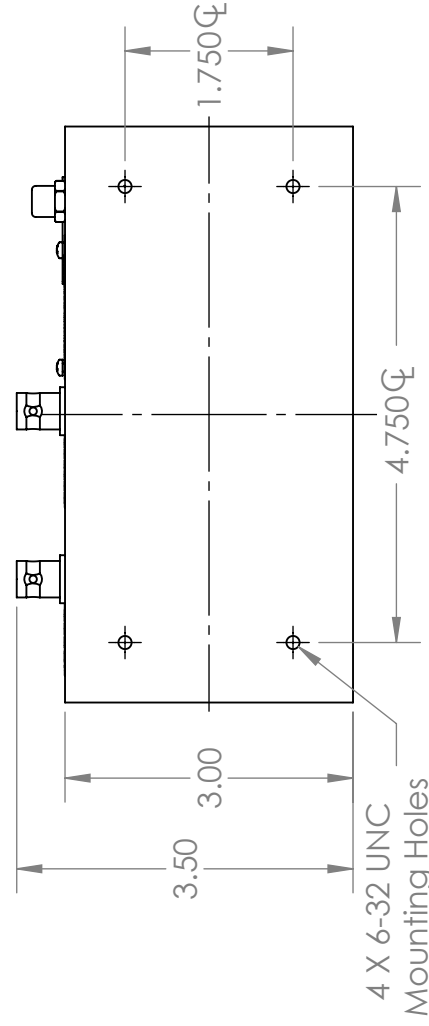
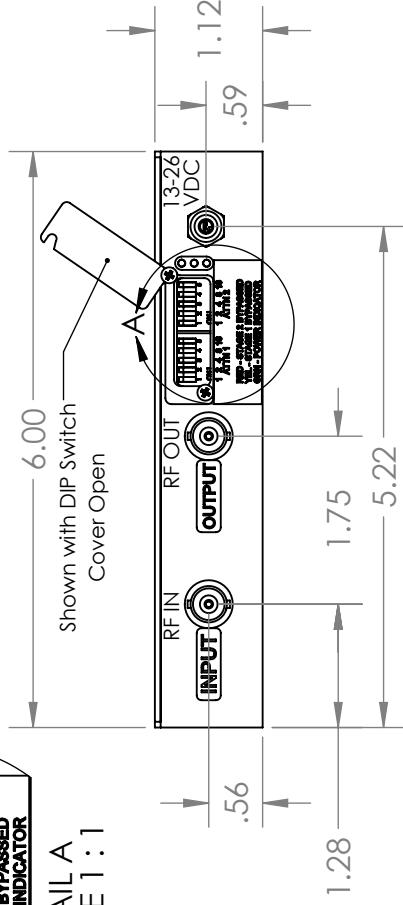

DRAWN <i>Paul Arnold</i>		DATE 01/16/26		APPROVED		DATE	
MATERIAL Aluminum, Brass, FR4, Copper, PTFE		FINISH Black Powder Coat		TITLE RX Amplifier, 50-1000 MHz		SCALE A 1:2	
UNLESS OTHERWISE SPECIFIED - DO NOT SCALE DRAWING ALL DIMENSIONS ARE IN INCHES * PERPENDICULAR SURFACES SQUARE WITHIN .003 REMOVE SHARP EDGES .010 MAX. * FILLET RADIUS .010 MAX. TOTAL RUNOUT WITHIN .005 ON COMMON DIAMETERS * ALL MACHINED SURFACES ⁶⁴ MAX.		TOLERANCES: X.X ± 0.1 X° ± 1° X.XX ± 0.01 X.X° ± 0.1° X.XXXX ± 0.005 X.XX° ± 0.05°		THE INFORMATION CONTAINED IN THIS DRAWING IS THE SOLE PROPERTY OF EMR CORPORATION. ANY REPRODUCTION IN PART OR WHOLE WITHOUT THE WRITTEN PERMISSION OF EMR CORPORATION IS PROHIBITED.		DWG NO.: 204316/3A-SPEC	
EMR Corporation Phoenix, AZ. 623-581-2875							

RX Amplifier Attenuator Control

Step 1: To access the attenuator control DIP switches, loosen, but do not remove these two screws.

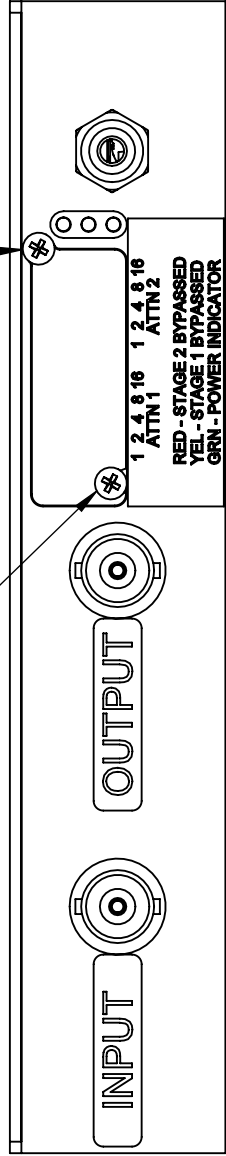

Step 2: Pivot the DIP switch cover plate to expose the DIP switches.

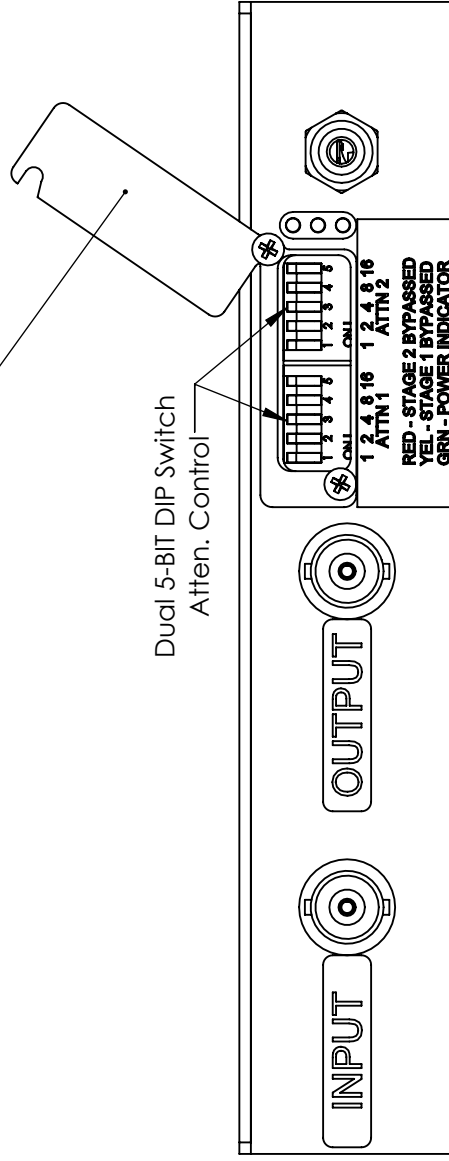

The amplifier has two 5 BIT digital attenuators in series, ATTN1 & ATTN2. Each attenuator can be set from 0 to 31 dB attenuation in 1 dB increments for a total of 62 dB. If all the DIP Switches are OFF (Up Position), there is no attenuation. If all the switches are ON (Down Position) the attenuation will be 62 dB.

See Sheet 2 for more detailed instructions.

<p>EMR Corporation Phoenix, AZ. 623-581-2875</p>		<p>DRAWN <i>Paul Arnold</i></p>	<p>TITLE RX Amplifier Attenuator Control</p>
<p>MATERIAL -</p>	<p>DATE 01/16/26</p>	<p>APPROVED</p>	<p>SCALE A 1:1</p>
<p>FINISH -</p>	<p>APPROVED</p>	<p>DATE</p>	<p>DWG NO.: 204316/3A-ATTN</p>
<p>UNLESS OTHERWISE SPECIFIED - DO NOT SCALE DRAWING ALL DIMENSIONS ARE IN INCHES * PERPENDICULAR SURFACES SQUARE WITHIN .003 REMOVE SHARP EDGES .010 MAX. * FILLET RADIUS .010 MAX. TOTAL RUNOUT WITHIN .005 ON COMMON DIAMETERS * ALL MACHINED SURFACES⁶⁴ MAX.</p>			
<p>THE INFORMATION CONTAINED IN THIS DRAWING IS THE SOLE PROPERTY OF EMR CORPORATION. ANY REPRODUCTION IN PART OR WHOLE WITHOUT THE WRITTEN PERMISSION OF EMR CORPORATION IS PROHIBITED.</p>			
<p>TOLERANCES: X.X ± 0.1 X° ± 1° X.XX ± 0.01 X.X° ± 0.1° X.XXXX ± 0.005 X.XX° ± 0.05°</p>			

Table 1: Attenuator DIP Settings (0 to 30 dB)
1 = ON (Down)
0 = OFF (Up)

Total Atten. (dB)	ATTN1 (dB)	ATTN1 DIP #	ATTN1 DIP Val.	ATTN2 Atten. (dB)	ATTN2 DIP #	ATTN2 DIP Val.
0	0	1	1	0	1	1
1	1	1	0	0	1	0
2	1	1	0	0	1	0
3	2	0	1	0	1	0
4	2	0	1	0	0	1
5	3	1	0	0	0	1
6	3	1	0	0	1	0
7	4	0	1	0	0	1
8	4	0	1	0	0	0
9	5	1	0	0	0	0
10	5	1	0	0	1	0
11	6	0	1	0	0	1
12	6	0	1	0	0	0
13	7	1	1	0	0	0
14	7	1	1	0	0	1
15	8	0	1	0	0	1
16	8	0	0	1	0	0
17	9	1	0	0	0	1
18	9	1	0	0	1	0
19	10	0	1	0	0	1
20	10	0	1	0	0	0
21	11	1	1	0	0	0
22	11	1	0	1	0	0
23	12	0	1	0	0	1
24	12	0	0	1	0	0
25	13	1	0	0	0	1
26	13	1	0	0	1	0
27	14	0	1	0	0	1
28	14	0	1	0	1	0
29	15	1	1	0	0	1
30	15	1	1	0	0	0

Table 2: Attenuator DIP Settings (31 to 62 dB)
1 = ON (Down)
0 = OFF (Up)

Total Atten. (dB)	ATTN1 (dB)	ATTN1 DIP #	ATTN1 DIP Val.	ATTN2 Atten. (dB)	ATTN2 DIP #	ATTN2 DIP Val.
31	16	0	0	0	1	1
32	16	0	0	0	1	0
33	17	1	0	0	1	0
34	17	1	0	0	0	1
35	18	0	1	0	0	1
36	18	0	1	0	0	0
37	19	1	1	0	0	0
38	19	1	0	1	0	0
39	20	0	1	0	0	1
40	20	0	0	1	0	0
41	21	1	0	0	0	1
42	21	1	0	0	1	0
43	22	0	1	0	0	1
44	22	0	1	0	0	0
45	23	1	1	0	0	0
46	23	1	1	0	1	0
47	24	0	0	1	0	0
48	24	0	0	0	1	0
49	25	1	0	0	0	1
50	25	1	0	0	1	0
51	26	0	1	0	0	1
52	26	0	1	0	0	0
53	27	1	1	0	0	0
54	27	1	0	1	0	0
55	28	0	0	1	0	1
56	28	0	0	0	1	0
57	29	1	0	0	0	1
58	29	1	0	0	1	0
59	30	0	1	0	0	1
60	30	0	1	0	0	0
61	31	1	1	0	0	0
62	31	1	1	0	0	0

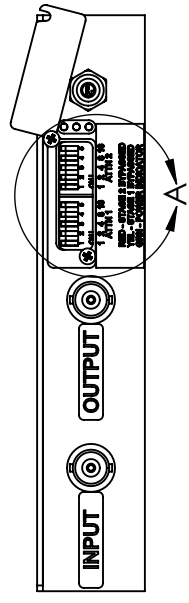

DETAIL A
SCALE 1:1

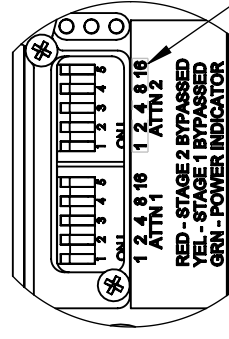

- DIP1 = 1 dB
- DIP2 = 2 dB
- DIP3 = 4 dB
- DIP4 = 8 dB
- DIP5 = 16 dB

These numbers show the attenuation value for each DIP Switch:

Total Attenuation is the value of ATN1 DIP plus the value of ATN2 DIP. For example, if ATN1 DIP has switches 1, 2, & 3 on then ATN1 is 1+2+4 = 7 dB, and if ATN2 DIP has switch 4 on then ATN2 is 8 dB; the total attenuation will be 7 dB + 8 dB = 15 dB. For optimal performance ATN1 and ATN2 settings should be as equal as possible. So, if one wants 3 dB attenuation, it is better to set ATN1 to 2 dB and ATN2 to 1 dB rather than just putting ATN1 to 3 dB.

See Tables 1 & 2 for a full list of settings.

EMR Corporation Phoenix, AZ. 623-581-2875	DRAWN <i>Paul Arnold</i>	MATERIAL -	
	DATE 01/16/26	FINISH -	
	APPROVED		
TITLE RX Amplifier Attenuator Control			
SCALE 1:2	SIZE A		
DWG NO. 204316/3A-ATTN			

UNLESS OTHERWISE SPECIFIED - DO NOT SCALE DRAWING
ALL DIMENSIONS ARE IN INCHES * PERPENDICULAR SURFACES SQUARE WITHIN .003
REMOVE SHARP EDGES .010 MAX. * FILLET RADIUS .010 MAX.
TOTAL RUNOUT WITHIN .005 ON COMMON DIAMETERS * ALL MACHINED SURFACES⁶⁴ MAX.

THE INFORMATION CONTAINED IN THIS DRAWING IS THE SOLE PROPERTY OF EMR CORPORATION. ANY REPRODUCTION IN PART OR WHOLE WITHOUT THE WRITTEN PERMISSION OF EMR CORPORATION IS PROHIBITED.

TOLERANCES:
X.X ± 0.1 X° ± 1°
X.XX ± 0.01 X.X° ± 0.1°
X.XXX ± 0.005 X.XX° ± 0.05°

EMR SERVICES

Consulting Services

EMR Corporation offers system design and antenna site maintenance consulting services. Our assistance in these areas is most often supplied as an adjunct to sales...part of the bargain to our customers. On complex projects our consulting fees are competitive within the industry and our recommendations are backed by many years of hands on experience.

If you have questions involving equipment not of our manufacture or systems not of our design we will be pleased to extend some "friendly advice". A friend made today is tomorrow's customer!

Equipment Problems

While most of our products are shipped ready to install, should problems arise we are ready to provide additional documentation and to give unlimited telephone support.

In the case of problems with factory supplied components, we offer a one year standard limited warranty. EMR enjoys an extremely low return rate. A warranty repair is a rare occurrence...it gets our attention and it gets a fast turnaround.

In the event of problems in installation we will do our best to get you "on-the-air" as soon as possible. A broken connector for example, or a frequency change, can be dealt with on a same day received basis; often gratis, or at a nominal charge.

Product Availability

Normal delivery on a complex device, such as a receiver multicoupler, is 4 to 5 weeks. We do, however, understand the word EMERGENCY. We are well aware of the expense of commercial rack space and of the costs in lost revenue due to down time. We keep reasonable stock of parts and assemblies on hand and we enjoy a very good relationship with our component suppliers. If you find yourself "caught short" you can rely on EMR for the fastest possible response to your needs.

Additional copies of this bulletin and bulletins dealing with other facets of RF filtering (hybrid transmitter combiners, cavity resonators, antenna duplexers, filter-ferrite combiners, isolators, power monitoring systems and site management) are available directly from:

EMR Corporation
22402 N. 19th Avenue
Phoenix, AZ. 85027
Tel: (623) 581-2875
Toll Free: 1-800-796-2875
Fax: (623) 582-9499
E-Mail: info@emrcorp.com
Web: emrcorp.com