

## DESCRIPTION AND MAINTENANCE

### 406-512 MHz, 40 WATT MASTR® II TRANSMITTER

#### TABLE OF CONTENTS

	Page
DESCRIPTION .....	1
MAINTENANCE .....	1
Disassembly .....	1
PA Transistor Replacement .....	4
Troubleshooting .....	6
Alignment Procedure .....	7
Test Procedures .....	8
Troubleshooting Procedures .....	9-10
ILLUSTRATIONS	
Figure 1 - Block Diagram .....	2
Figure 2 - Access to Station Exciter, Front View .....	3
Figure 3 - Access to Station Power Amplifier, Rear View .....	3
Figure 4 - Disassembly Procedure (Top and Bottom View) .....	3
Figure 5 - PA Transistors Lead Identification and Mounting (Q202) .....	5
Figure 6 - PA Transistors Lead Identification (Q203 and Q204) .....	5
Figure 7 - Frequency Characteristics Vs. Temperature .....	7
Figure 8 - Power Output Setting Chart (406-470 MHz) .....	7
Figure 9 - Power Output Setting Chart (470-494 MHz) .....	7
Figure 10 - Power Output Setting Chart (494-512 MHz) .....	7

## DESCRIPTION

40 Watt MASTR® II transmitters are crystal controlled, phase modulated transmitters designed for one through eight frequency operation in the 406-512 MHz frequency bands. The solid state transmitter utilizes both integrated circuits (ICs) and discrete components, and consists of the following assemblies:

- Exciter Board; with audio, modulator, amplifier and multiplier stages.
- Power Amplifier Assembly; with amplifier, driver, PA, power control, filter and antenna switch.

Figure 1 is a block diagram of the MASTR II transmitters, showing the exciter board and Power Amplifier Assembly.

The Exciter contains up to eight Integrated Circuit Oscillator Modules (ICOMs), Audio IC, modulator, and multipliers to provide 185 milliwatts (minimum) of modulated RF power to the Power Amplifier Assembly.

The Power Amplifier Assembly includes a Power Amplifier Module with power control, and a Low Pass Filter/Antenna Switch Module. The four RF power transistor stages

on the Power Amplifier Module provide up to 40 Watts of output power adjusted by the power adjust circuitry.

## MAINTENANCE

The PA assembly is insulated from vehicle ground to permit operation in positive or negative ground vehicles.

#### NOTE

In positive ground vehicles, A- is "hot" with respect to vehicle ground. Shorting the transmitter PA printed wiring board ground pattern to the radio case may cause one of the in-line fuses to blow.

## MOBILE DISASSEMBLY

- To service the transmitter from the top:
  1. Pull the locking handle down, then pry up the cover at the front notch and lift off the cover.
- To service the transmitter from the bottom:

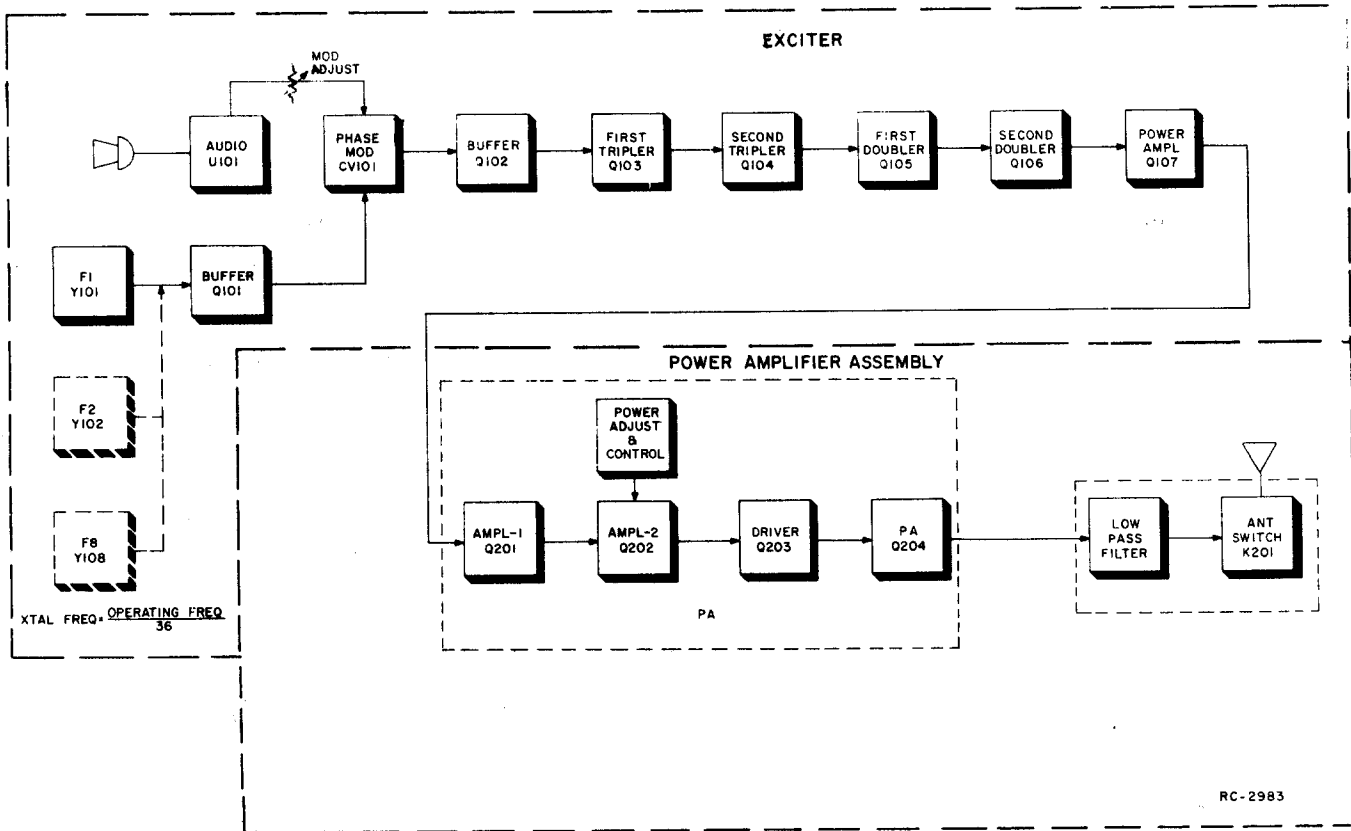

Figure 1 - Transmitter Block Diagram

1. Pull the locking handle down and pull the radio out of the mounting frame.
2. Remove the top cover, then loosen the two bottom cover retaining screws and remove the bottom cover (see Figure 4).
3. To gain access to the bottom of the exciter board, remove the six screws (A) holding the exciter board and its bottom cover to the module mounting frame, and remove the bottom cover.

1. Turn the two latching knobs (A) counterclockwise to unlatch the Radio Panel Front Door. Refer to Figure 2.
2. Swing the Radio Panel Front Door down as shown.
3. Remove covers.

To service the transmitter Power Amplifier from the rear:

1. Remove the top two screws (B) on the Intermittent or Continuous Duty Power Amplifier. Refer to Figure 3.
2. Swing the Power Amplifier down as shown. Remove the top cover of the Power Amplifier.

NOTE

Be careful not to bend the three pins on the exciter board bottom cover during removal or installation of the cover.

NOTE

If the heatsink blower option is present, this blower must be removed before the Power Amplifier can be lowered.

STATION DISASSEMBLY

For a more complete mechanical parts breakdown refer to the station manual. To service the transmitter exciter from the front:

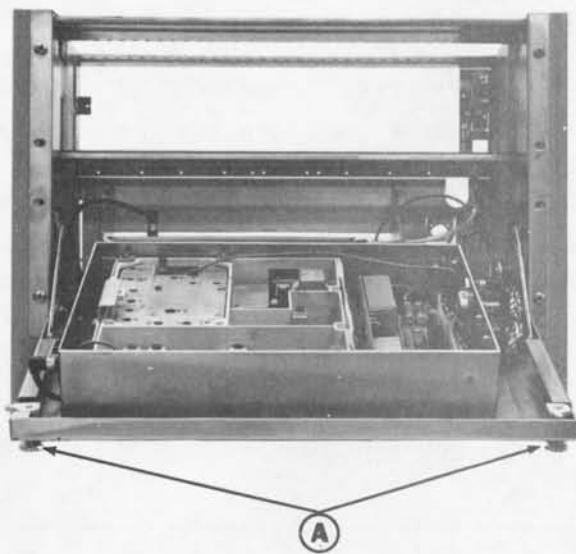

Figure 2 - Access to Exciter Front View

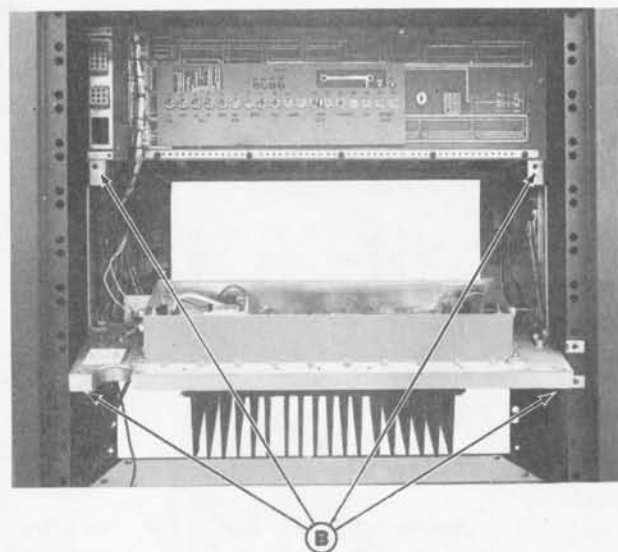

Figure 3 - Access to Power Amplifier Rear View

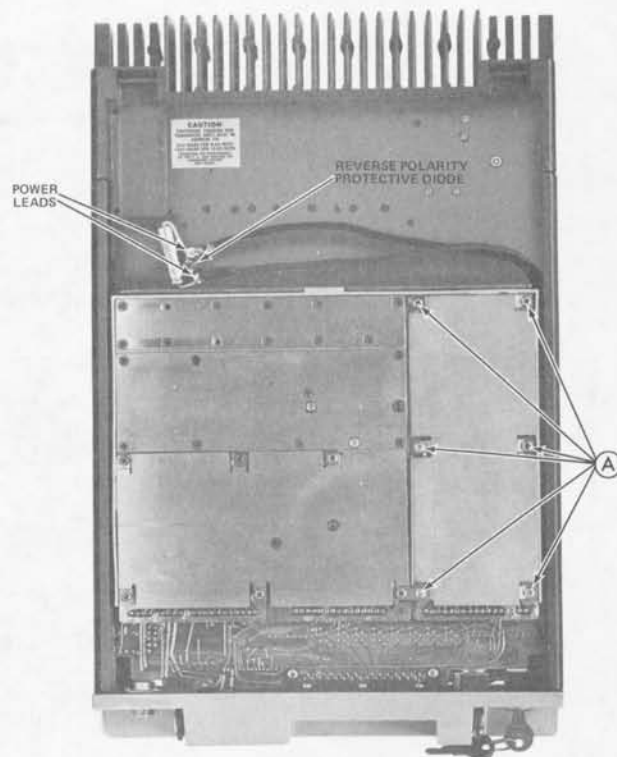
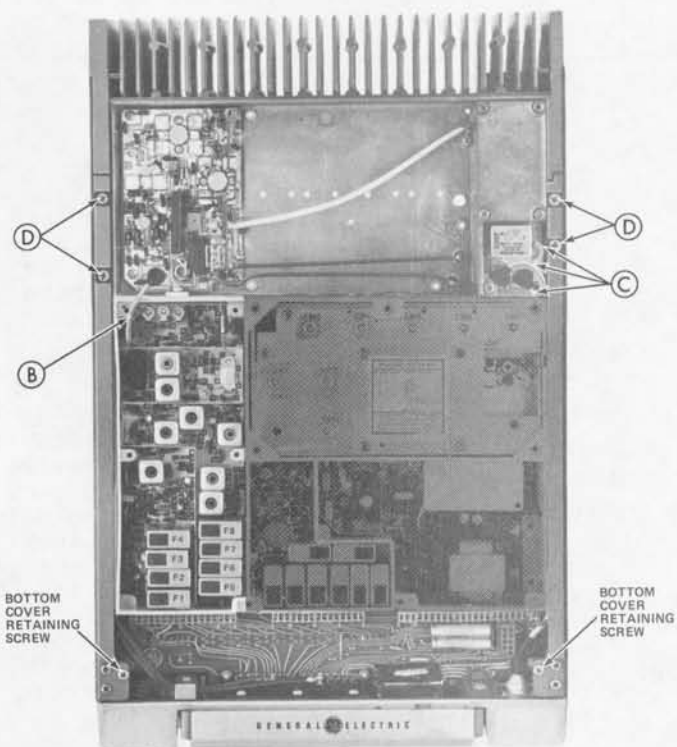

Figure 4 - Disassembly Procedure

## EXCITER DISASSEMBLY

- To remove the exciter board: (see Figure 4)
  1. Unplug the exciter/PA cable (B).
  2. Remove the six screws A holding the exciter board and its bottom cover to the module mounting frame.
  3. Press straight down on the plug-in exciter from the top to avoid bending the pins when unplugging the board from the system board jack.

## PA DISASSEMBLY

- To remove the PA assembly: (see Figure 4)
  1. Remove the PA top cover and unplug the exciter/PA cable (B), the antenna, receiver and PTT cables (C).
  2. Remove the four side-rail screws (D), and unsolder the power cables from the bottom of the PA assembly if desired.
- To remove PA module: (see PA Assembly/Outline Diagram - LBI-30213)
  1. Remove the PA top cover and unplug the exciter/PA cable.
  2. Unsolder power feed cables W214 from G211 and W215 from E201.
  3. Unsolder 50-ohm cable W218 from W205 and Disconnect G212 (ground).

## NOTE

The center conductor of W218 must be soldered to W205 in the area indicated. The ground braid at G212 is connected to vehicle ground by the board mounting screw. The ground braid must not touch ground (A-) on the 40 Watt module.

4. Unsolder thermistor (RT201) leads.
5. Remove Q215 retaining screw, nut and washer from heat sink assembly.
6. Remove Q202 transistor hold-down nut and spring washer on the bottom of the PA assembly.
7. Remove Q203 and Q204 transistor mounting screws (2 each), and nuts and washers on bottom of the PA assembly.

8. Remove the four remaining PA board mounting screws, and lift the board out.

- To remove Low Pass Filter/Antenna Switch Module: (see PA Assembly Outline Diagram - LBI-30213)
  1. Remove the PA top cover
  2. Remove antenna and receiver plugs, and disconnect PTT cables.
  3. Unsolder 50-ohm cable W218 from W4208 and disconnect G4214 (ground).
  4. Remove the six mounting screws, lift off the filter casting, and lift the board out.

## PA TRANSISTOR REPLACEMENT

## WARNING

The RF Power Transistor used in the transmitter contains Beryllium Oxide, a TOXIC substance. If the ceramic or other encapsulation is opened, crushed, broken or abraded, the dust may be hazardous if inhaled. Use care in replacing transistors of this type.

- To remove PA RF transistor Q202:
  1. With a 50-Watt soldering iron and a de-soldering tool such as the SOLDA-PULLT®, remove the excess solder from the leads. Use a scribe or X-acto® knife to hold the leads away from the printed circuit board until the solder cools.
  2. Turn the PA Assembly over.
  3. Hold the body of the transistor to prevent it from turning. Remove the transistor hold-down nut and spring washer through the hole in the heatsink with an 11/32-inch nut-driver for Q202. Lift out the transistor, and remove the old solder from the printed circuit board with a de-soldering tool such as a SOLDA-PULLT®. Special care should be taken to prevent damage to the printed circuit board runs because part of the matching network is included in the base and collector runs. Do not misalign the copper spacer located between the transistor body and the heatsink.
- To remove RF PA transistor Q203 and Q204 (Flange Type):

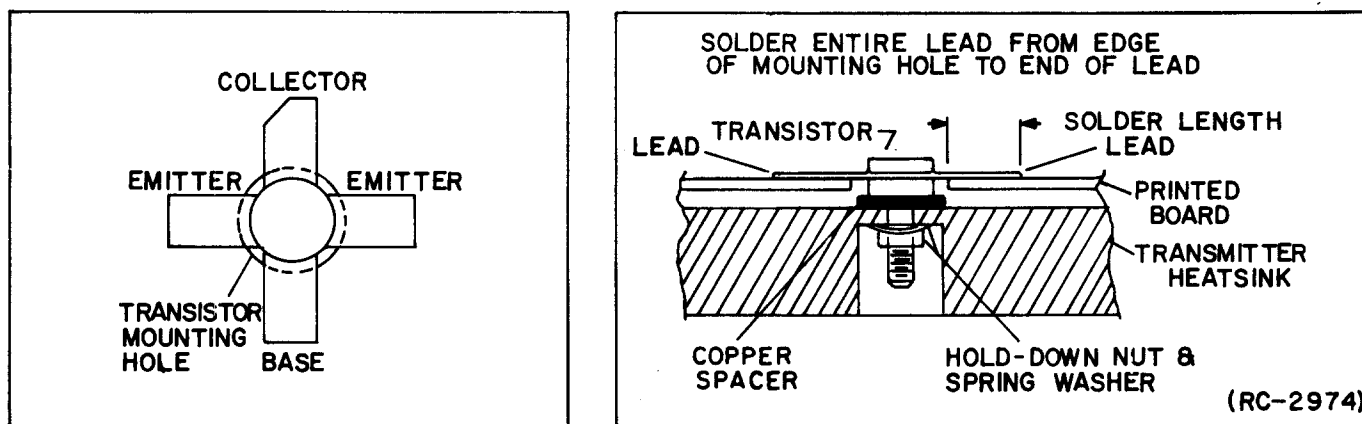

Figure 5 - Q202 Lead Identification and Mounting

1. With a 50-Watt soldering iron and a de-soldering tool such as the SOLDA-PULLT®, remove the excess solder from the leads. Use a scribe or X-acto® knife to hold the leads away from the printed circuit board until the solder cools.
2. Turn the PA Assembly over.
3. Hold the nuts on the bottom of the heatsink with a 3/16-inch nut-driver and remove the two retaining screws. Lift out the transistor, and remove the old solder from the printed circuit board with a de-soldering tool such as a SOLDA-PULLT®. Special care should be taken to prevent damage to the printed circuit board runs because part of the matching network is included in the base and collector runs.

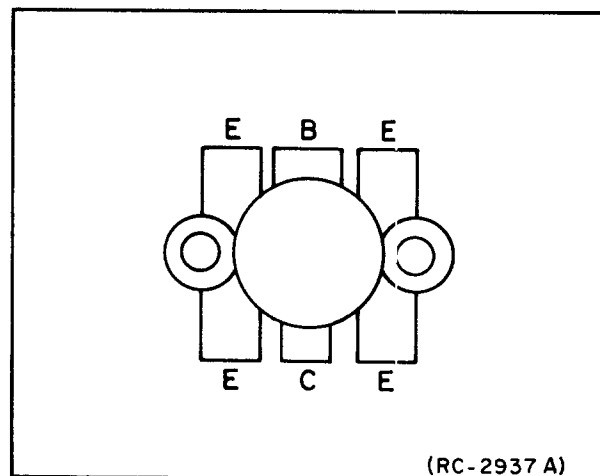

Figure 6 - Q203 & Q204 Lead Identification

To replace RF PA transistors:

1. Trim the new transistor leads (if required) to the lead length of the removed transistor. Cut the collector lead of Q202 at a 45° angle for future identification. (see Figure 5). The collector lead of Q203 and Q204 is identified by the smaller center lead (see Figure 6). The letter "C" on top of each transistor also identifies the collector.
2. Apply a coat of silicon grease around the transistor mounting surface Q202, Q203 and Q204. Be sure the copper spacer for Q202 is properly aligned on the heatsink and place the transistor in the mounting hole. Align the leads as shown on the Outline Diagram (PA Assembly - LBI-30213). Then hold the body of the transis-

tor and replace the hold-down nut and spring-washer (Q202) or the two retaining screws Q203 and Q204 using moderate torque, 8 inch-pounds for Q203 and Q204. A torque wrench must be used for this adjustment since transistor damage can result if too little or too much torque is used.

3. Solder the leads to the printed circuit pattern. Start at the inner edge of mounting hole and solder the remaining length of transistor lead to the board. Do not use excessive heat which causes the printed wire runs to lift up from the board. Check for shorts and solder bridges with an ohmmeter before applying power.

**CAUTION**

Failure to solder the transistor leads as directed may result in the generation of RF loops that could damage the transistor or may cause low power output.

**TROUBLESHOOTING**

A Troubleshooting Procedure, including QUICK CHECKS, permits rapid fault location in the exciter and power amplifier.

GENERAL ELECTRIC COMPANY • MOBILE COMMUNICATIONS DIVISION  
WORLD HEADQUARTERS • LYNCHBURG, VIRGINIA 24502 U.S.A.

**GENERAL**  **ELECTRIC\***  
U.S.A.

\* Trademark of General Electric Company U.S.A.  
Printed in U.S.A.

MODULATION LEVEL ADJUSTMENT

The MOD ADJUST (R104) was adjusted to the proper setting before shipment and should not normally require re-adjustment.

TEST EQUIPMENT

- 1. An audio oscillator
2. A frequency modulation monitor
3. An output meter or a Voltmeter
4. GE Test Set Model 4EX3A11 or 4EX8K12

MOBILE PROCEDURE

- 1. Connect the audio oscillator and the meter across audio input terminals J10 (Green-Hi) and J11 (Black-Lo) on GE Test Set, and connect red Test Set plug to the System red metering plug.
2. Adjust the audio oscillator for 1-Volt RMS at 1000 Hz.
3. For transmitters without Channel Guard, set MOD ADJUST R104 for a 4.5-kHz swing with the deviation polarity which gives the highest reading as indicated on the frequency modulation monitor.
4. For transmitters with Channel Guard, set Channel Guard MOD ADJUST R105 for zero tone deviation.
5. For multi-frequency transmitters, set the deviation as described in Steps 3 or 4 on the channel producing the largest amount of deviation.

STATION PROCEDURE

- 1. Connect the audio oscillator and the meter across audio input terminals J10 (Green-Hi) and J11 (Black-Lo) on GE Test Set, and connect red Test Set plug to the System red metering plug.
2. Set the audio generator frequency to 1 kHz.
3. For transmitters without Channel Guard, set MOD ADJUST R104 for a 4.5 kHz swing with the deviation polarity which gives the highest reading as indicated on the frequency modulation monitor.
4. For transmitters with Channel Guard, set Channel Guard MOD ADJUST R105 for zero tone deviation.
5. For multi-frequency transmitters, set the deviation as described in Steps 3 or 4 on the channel producing the largest amount of deviation.

PA POWER INPUT

For FCC purposes, the PA power input can be determined by measuring the PA supply voltage and PA current, and using the following formula:

P1 = PA voltage x PA current

where:

P1 is the power input in Watts,

PA voltage is measured with Test Set Model 4EX3A11 in Position F on the 15-Volt range (read as 15 Volts full scale), and with the polarity switch in the (-) position.

PA current is measured with the Test Set in Position F in the Test 1 position, and with the HIGH SENSITIVITY button pressed (15 amperes full scale).

Example:

P1 = 13.4 Volts x 6 amperes = 80.4 Watts

RC-2453

ICOM FREQUENCY ADJUSTMENT

First, check the frequency to determine if any adjustment is required. The frequency should be set with a frequency meter or counter with an absolute accuracy that is 5 to 10 times better than the tolerance to be maintained.

MASTR II ICOMs should be reset only when the frequency shows deviation in excess of the following limits:

- A. +/-0.5 PPM, when the radio is at 26.5°C (79.8°F).
B. +/-2 PPM at any other temperature within the range of -5°C to +55°C (+23°F to +131°F).
C. The specification limit (+2 PPM or +/-5 PPM) at any temperature within the range of -40°C to -5°C (-40°F to +23°F) or +55°C to +70°C (+131°F to +158°F).

If any adjustment is required, pry up the cover on the top of the ICOM to expose the trimmer, and use one of the following procedures:

If the radio is at an ambient temperature of 26.5°C (79.8°F), set the oscillator for the correct operating frequency.

If the radio is not at an ambient temperature of 26.5°C, setting errors can be minimized as follows:

- A. To hold the setting error to +/-0.6 PPM (which is considered reasonable for 5 PPM ICOMs):
1. Maintain the radio at 26.5°C (+/-5°C) and set the oscillator to desired frequency.
2. Maintain the radio at 26.5°C (+/-10°C) and offset the oscillator, as a function of actual temperature, by the amount shown in Figure 7.
B. To hold the setting error to +/-0.35 PPM (which is considered reasonable for 2 PPM ICOMs):
1. Maintain the radio at 26.5°C (+/-5°C) and offset the oscillator as a function of actual temperature, by the amount shown in Figure 7.

For example: Assume the ambient temperature of the radio is 18.5°C (65.4°F). At that temperature, the curve shows a correction factor of 0.3 PPM. (At 406 MHz, 1 PPM is 406 Hz. At 512 MHz, 1 PPM is 512 Hz).

With an operating frequency of 450 MHz, set the oscillator for a reading of 135 Hz (0.3 x 450 Hz) higher than the licensed operating frequency. If a negative correction factor is obtained (at temperatures above 26.5°C), set the oscillator for the indicated PPM lower than the licensed operating frequency.

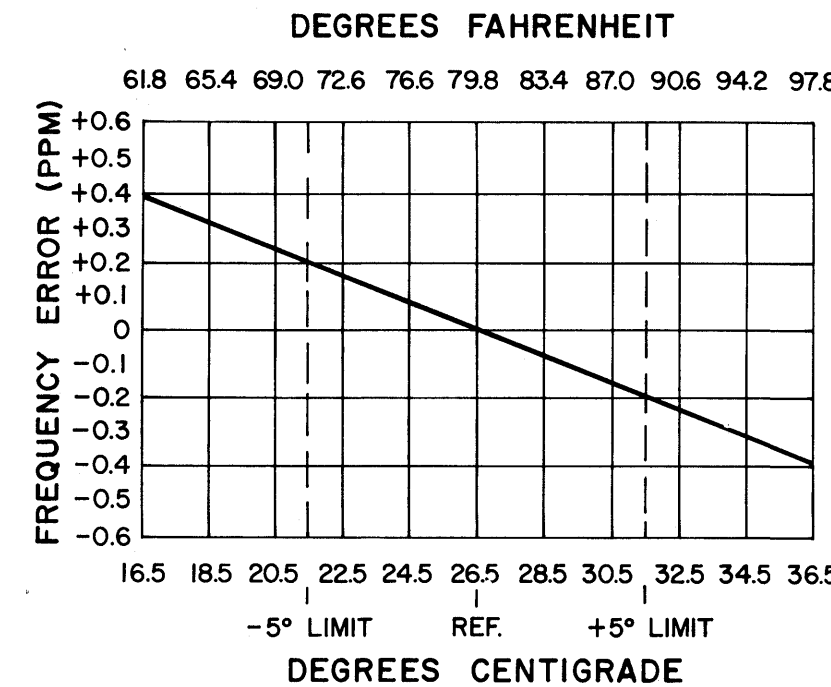

Figure 7 - Frequency Characteristics Vs. Temperature

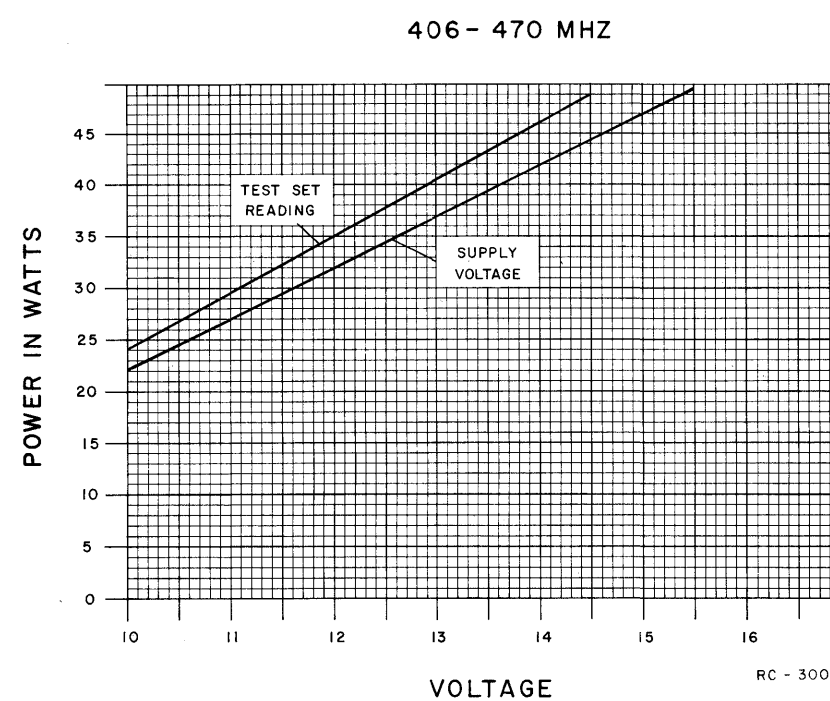
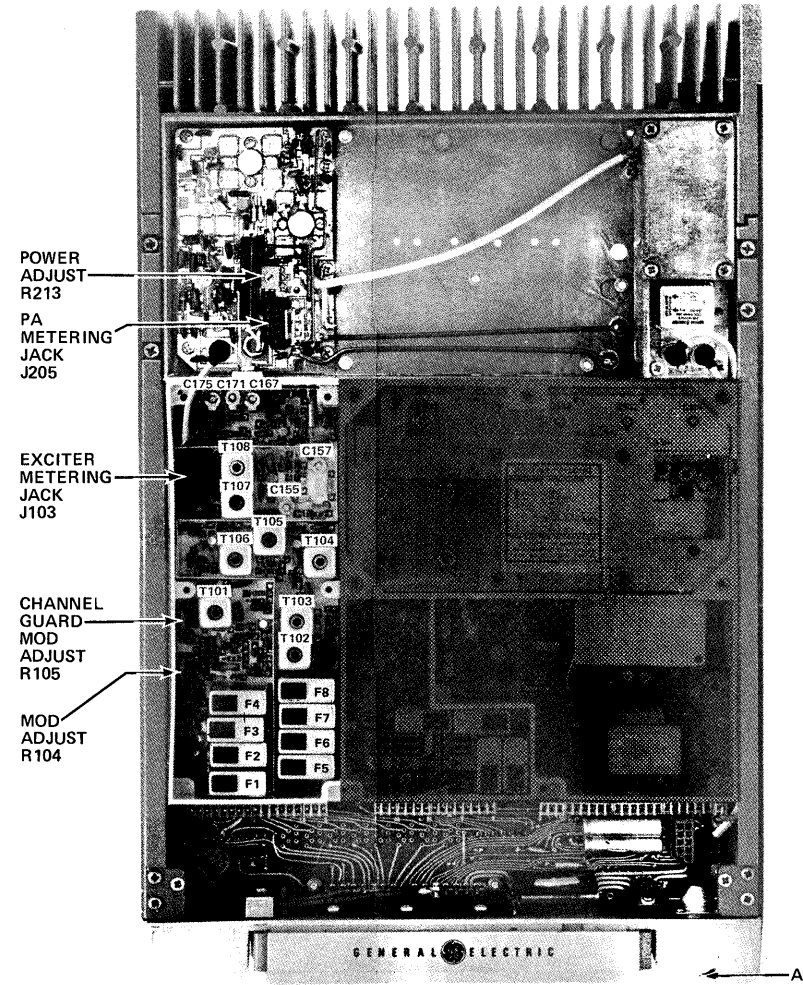

Figure 8 - Power Output Setting Chart

EQUIPMENT REQUIRED

- 1. GE Test Set Model 4EX3A11 or Test Kit 4EX8K12.
2. a 50-ohm wattmeter connected to antenna jack J906.
3. A frequency counter.

PRELIMINARY CHECKS AND ADJUSTMENTS

- 1. Place ICOMs on Exciter Board (crystal frequency - operating frequency + 36).
2. For a large change in frequency or a badly mis-aligned transmitter, preset all slugs to the top of the coil form.
3. Set output impedance matching capacitor C175 to 1/3 mesh.
4. Set all other air variable capacitors to minimum capacity (not meshed).

NOTE: The tuning frequency for multi-frequency transmitters is determined by the operating frequency and the frequency spread between transmitters. Refer to the table below for maximum frequency spread.

Table: Multi-frequency Transmitter Tuning. Columns include Transmitter Frequency Range, (1) Without center tuning, (2) With center tuning, and (3) With center tuning (1 dB degradation).

- 6. Connect the red plug on the GE Test Set to the System Board metering jack, and the black plug to the Exciter metering jack. Set the polarity to +, and set the range to the Test 1 position (1-Volt position for 4EX8K12) for all adjustments.

NOTE: With the Test Set connected to the PA metering jack, the voltage reading at position 'F' with the HIGH SENSITIVITY button pressed may be converted to PA collector current by reading the current as 15 amperes full scale.

- 7. All adjustments are made with the transmitter keyed. Unkey the transmitter between steps to avoid unnecessary heating.

NOTE: When the need for minor adjustments to the transmitter are indicated, perform steps 13 through 17 for a quick transmitter tune-up.

ALIGNMENT PROCEDURE

Table: Alignment Procedure. Columns include Step, Meter Position, Tuning Control, Meter Reading, and Procedure.

NOTE: When aligning transmitter, proceed as instructed below. DO NOT return a previously tuned control unless specifically directed to do so.

ALIGNMENT PROCEDURE (Cont'd)

Table: Alignment Procedure (Cont'd). Columns include Step, Meter Position, Tuning Control, Meter Reading, and Procedure.

NOTE: A quick transmitter tune-up procedure is provided in steps 13 through 18.

NOTE: The PA collector voltage is measured as described in the PA POWER INPUT section.

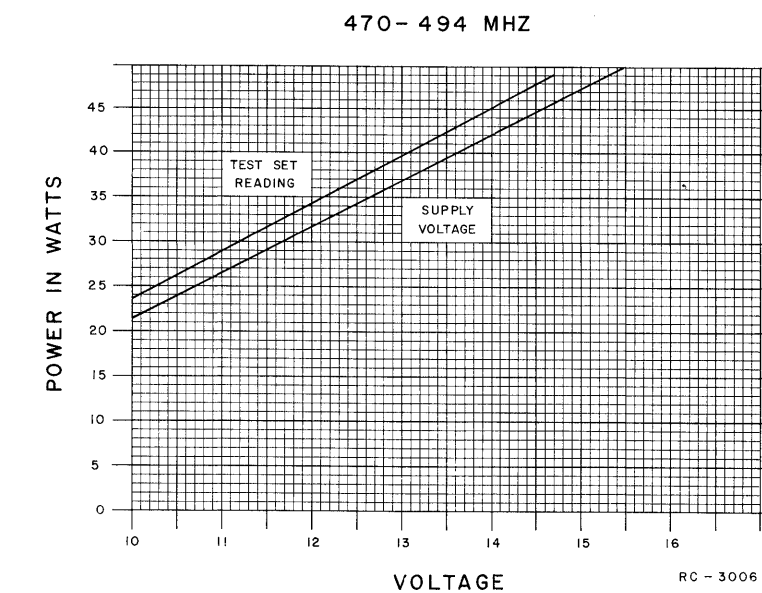

Figure 9 - Power Output Setting Chart

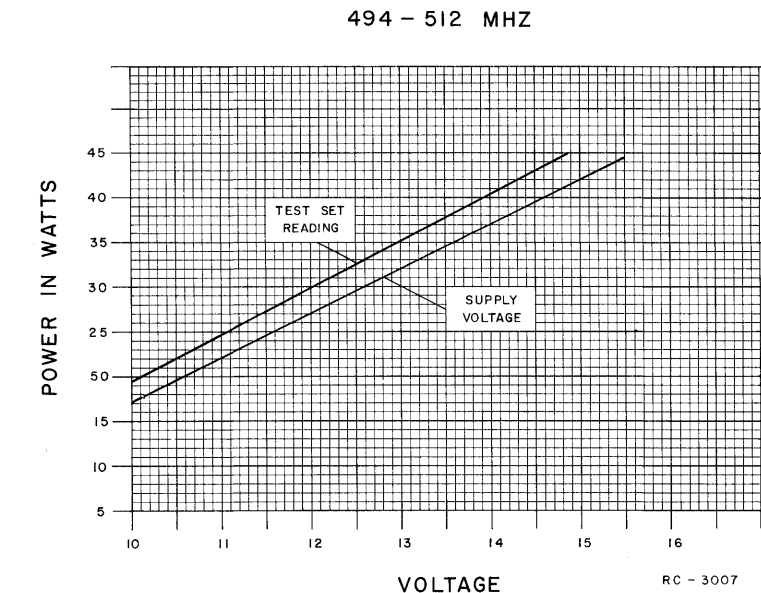

Figure 10 - Power Output Setting Chart

**TEST PROCEDURES**

These Test Procedures are designed to assist you in servicing a transmitter that is operating-- but not properly. Problems encountered could be low power output, tone and voice deviation, defective audio sensitivity, and modulator adjust control set too high. Once a defect is pin-pointed,

refer to the "Service Check" and the additional corrective measures included in the Transmitter Troubleshooting Procedure. Before starting with the Transmitter Test Procedures, be sure the transmitter is tuned and aligned to the proper operating frequency.

**CAUTION**

Before bench testing the MASTR II Mobile Radio, be sure of the output voltage characteristics of your bench power supply.

To protect the transmitter power output transistors from possible instant destruction, the following input voltages must not be exceeded:

Transmitter unkeyed: 20 Volts  
 Transmitter keyed (50 ohm resistive load): 18 Volts  
 Transmitter keyed (no load or non-resistive load): 15.5 Volts

These voltages are specified at the normal vehicle battery terminals of the radio and take the voltage drop of standard cables into account. The voltage limits shown for a non-optimum load is for "worst case" conditions. For antenna mismatches likely to be encountered in practice, the actual limit will approach the 18 Volt figure.

Routine transmitter tests should be performed at EIA Standard Test Voltages (13.6 VDC for loads of 6 to 16 amperes; 13.4 VDC for loads of 16 to 36 amperes). Input voltages must not exceed the limits shown, even for transient peaks of short duration.

Many commonly used bench power supplies cannot meet these requirements for load regulation and transient voltage suppression. Bench supplies which employ "brute force" regulation and filtering (such as Lapp Model 73) may be usable when operated in parallel with a 12-Volt automotive storage battery.

**TEST EQUIPMENT REQUIRED**

for test hookup as shown:

1. Wattmeter similar to: Bird # 43  
Jones # 711N
2. VTVM similar to: Triplet # 850  
Heath # IM-21
3. Audio Generator similar to: GE Model 4EX6A10
4. Deviation Meter (with a .75 kHz scale) similar to: Measurements # 720
5. Multimeter similar to: GE TEST SET MODEL 4EX3A11,  
MODEL 4EX8K12 or  
20,000 ohms-per-Volt voltmeter

**POWER MEASUREMENT****TEST PROCEDURE**

1. Connect transmitter output from the antenna jack to the wattmeter through a 50-ohm coaxial cable. Make sure the wattmeter is terminated into a 50-ohm load.
2. Key the transmitter and check the wattmeter for the desired power output.

**SERVICE CHECK**

Check the setting of the Power Adjust Control (R213).

Refer to the QUICK CHECKS on the Transmitter Troubleshooting Procedure.

**VOICE DEVIATION, SYMMETRY AND AUDIO SENSITIVITY****TEST PROCEDURE**

1. Connect the test equipment to the transmitter as shown.
2. In radios with Channel Guard, set Channel Guard Mod Adjust R105 for zero tone deviation.
3. In Mobile and Local Control Intermittent Duty Station combinations only, set the audio generator output to 1.0 volt RMS and the frequency to 1 kHz.  
  
In all other Station combinations, set the audio generator output to 30 millivolts RMS and the frequency to 1 kHz.
4. Key the transmitter and adjust Deviation Meter to carrier frequency.
5. Deviation reading should be  $\pm 4.5$  kHz in radios without Channel Guard, and  $\pm 3.75$  kHz in radios with Channel Guard.
6. If necessary, adjust MOD ADJUST control R104 for the proper deviation on plus (+) or minus (-) deviation, whichever is greater.

**NOTES:---** MASTR II transmitters are adjusted for 4.5 kHz deviation at the factory. The factory adjustment will prevent the transmitter from deviating more than 5.0 kHz under the worst conditions of frequency, voltage and temperature.

7. If the deviation reading plus (+) or minus (-) differs by more than 0.5 kHz, recheck Steps 1 and 2 as shown in the Transmitter Alignment Chart.
8. Check Audio Sensitivity by reducing generator output until deviation falls to 3.0 kHz for radios without Channel Guard, or 2.25 kHz for radios with Channel Guard. Voltage should be LESS than 120 millivolts. If not, refer to the Transmitter Troubleshooting Procedure.

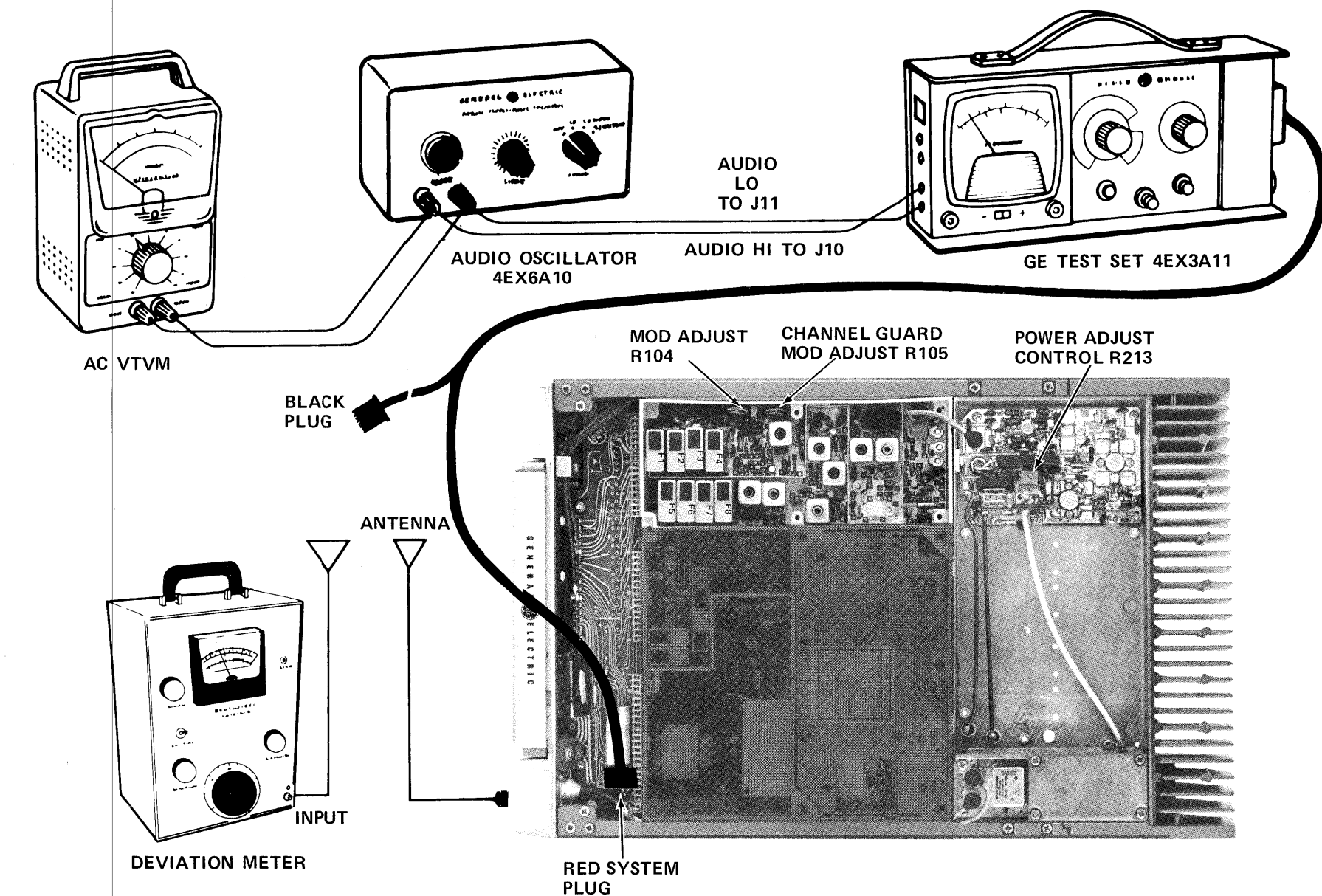
**TONE DEVIATION WITH CHANNEL GUARD****TEST PROCEDURE**

1. Set up the Deviation Meter and monitor the output of the transmitter.
2. Remove the 1000 Hz signal from the audio generator.
3. Key the transmitter and check for 0.75 kHz deviation. If the reading is low or high, adjust Channel Guard MOD ADJUST R105 for a reading of 0.75 kHz.

**NOTES:**

1. On units supplied with Channel Guard, the Phase Modulator Tuning should be adjusted carefully to insure proper performance. (Refer to Step 1 in the Transmitter Alignment Chart).
2. The Tone Deviation Test Procedures should be repeated every time the Tone Frequency is changed.



### STATION METERING

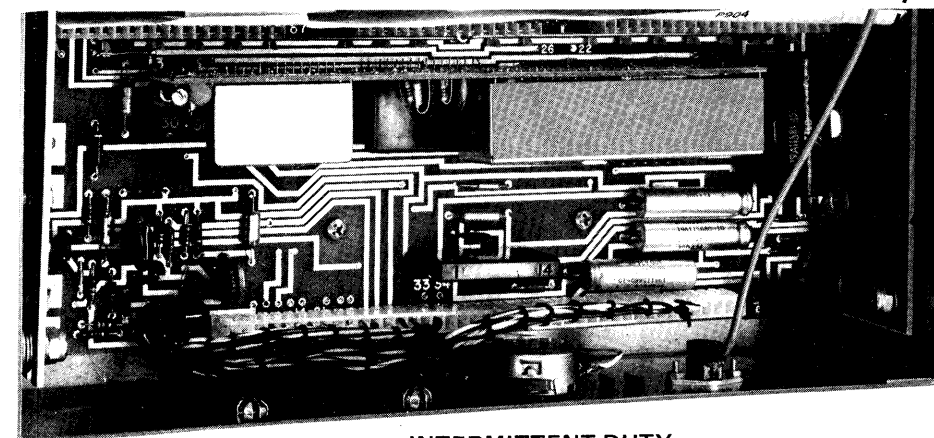
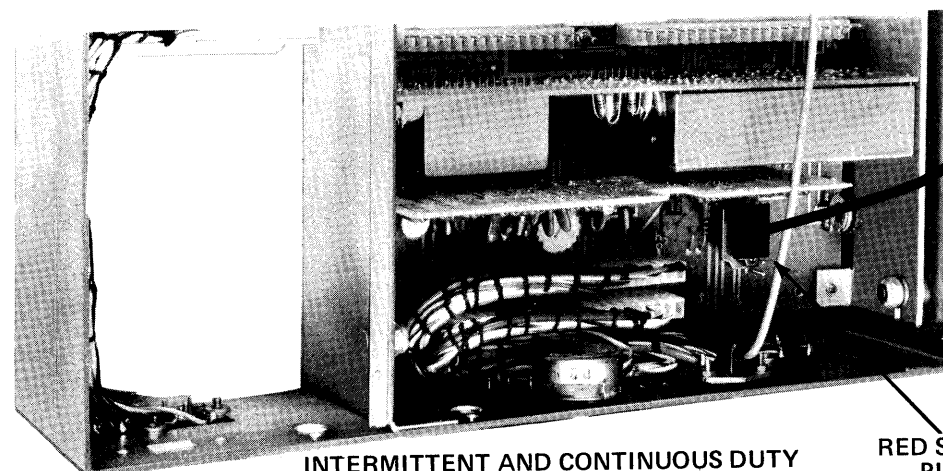
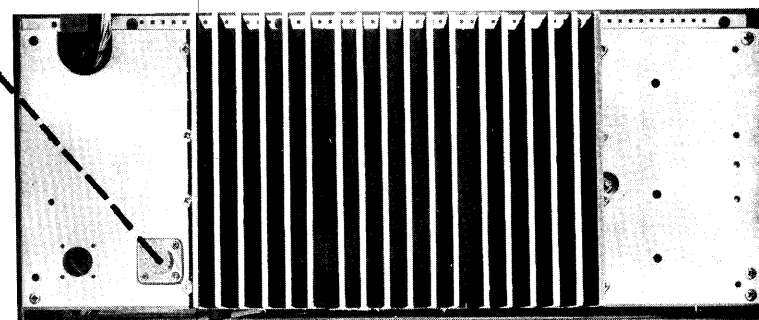
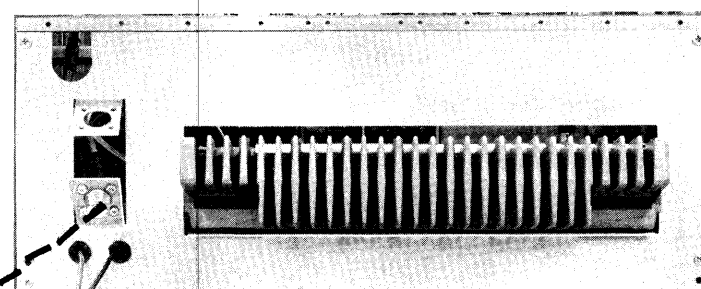
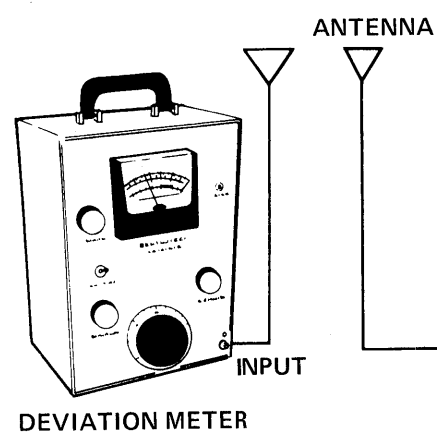
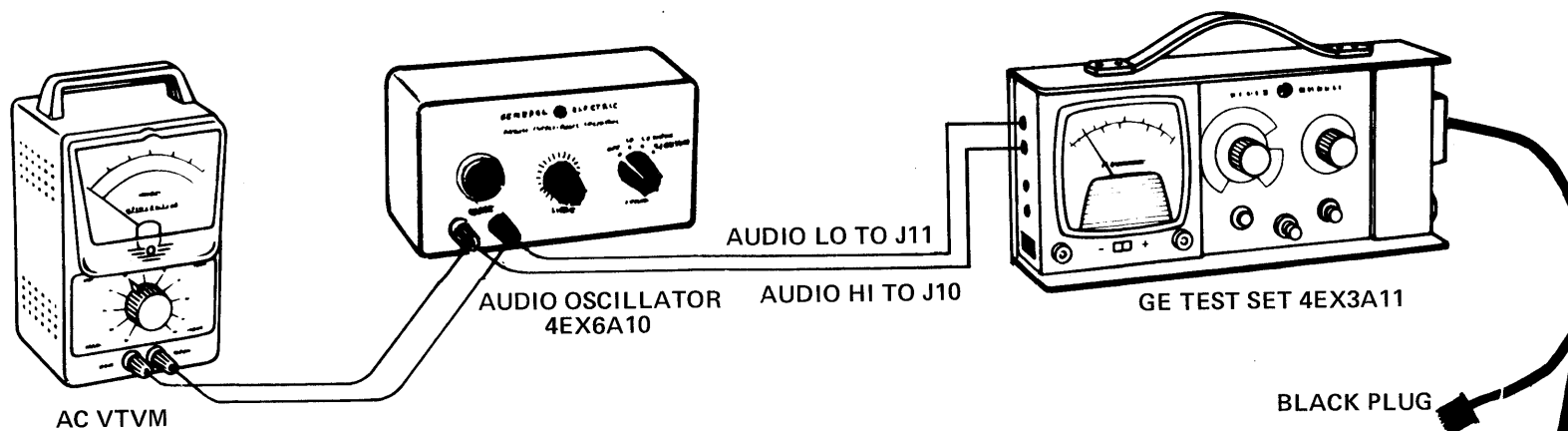

RED SYSTEM PLUG

### TROUBLESHOOTING PROCEDURE

406—512 MHz, 40 WATT TRANSMITTER

STEP I - QUICK CHECKS

METER POSITION GE TEST SET	PROBABLE DEFECTIVE STAGE		
	HIGH METER READING	LOW METER READING	ZERO METER READING
EXCITER			
B (MULT-1)	Q102, Q103, T102	Q102, Q103, T102	Q102, Q103, T102
C (MULT-2)	Q104, T105	T102, T103, Q104, T104	T102, T104, Q104, T105, T103
D (MULT-3)	Q105, T107	T105, T106, Q105	T105, T106, Q105, T107
F (MULT-4)	Q106, C155	Q106, T107, T108	Q106, T107, T108, L104
G (AMPL-1)	Q107, L113	Q107, C115 - C157	Q107, C155 - C157, L107
POWER AMPLIFIER			
C (Power Control)		Q215, R213, VR201, VR202, U201, Q202	Q215, R213, VR201, VR202, U201
"D" (AMPL-1 INPUT)		Low Output Exciter, CR201	No Output Exciter, CR201, C205
"F" (PA CURRENT)	Q204, T205	Q204, Low Output Q203	Q204, No Input From Q203. Check Pos C & D

STEP 3  
CHECK AUDIO AC VOLTAGES

EQUIPMENT REQUIRED  
 • AUDIO OSCILLATOR  
 • AC VOLTMETER

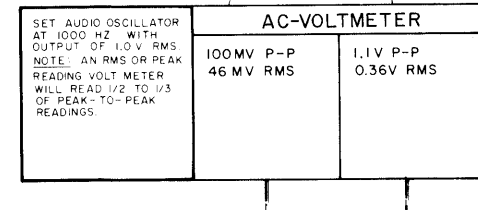
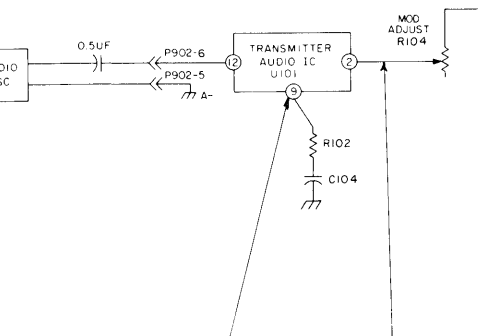

STEP 4  
AUDIO & OSC WAVEFORMS

EQUIPMENT REQUIRED  
 • AUDIO OSCILLATOR  
 • OSCILLOSCOPE

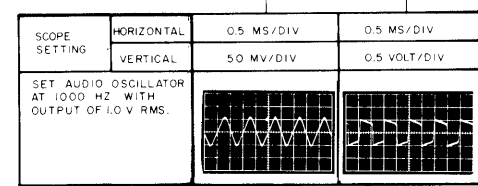

STEP 2  
CHECK TYPICAL DC VOLTAGES

EQUIPMENT REQUIRED  
 • S.E. TEST MODEL 4633A11  
 OR  
 • 20,000 OHM-PER-VOLT METER

NOTE: ALL DC READINGS TAKEN WITH THE TRANSMITTER KEYS.

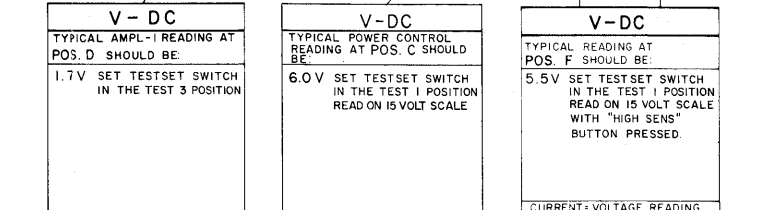
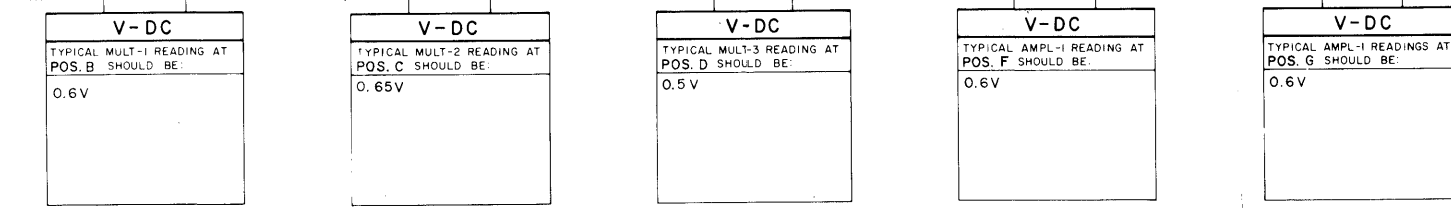
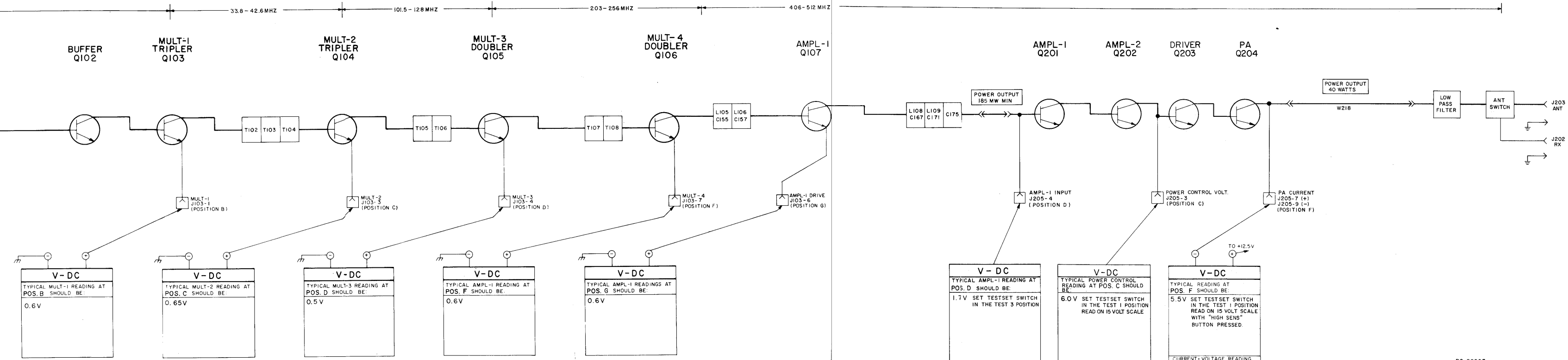

RC-2986B

TROUBLESHOOTING PROCEDURE

406-512 MHz, 40 WATT TRANSMITTER