

**MAINTENANCE MANUAL
CONSOLE INTERFACE BOARD 19D438451G1
FOR
EDACS VOTER APPLICATIONS**

TABLE OF CONTENTS

	<u>Page</u>
CONSOLE INTERFACE BOARD	Front Cover
2175 Hz TONE GENERATOR	Front Cover
2175 Hz TONE DETECTOR	1
POWER DISTRIBUTION	1
TEST AND TROUBLESHOOTING	1
Equipment Required	1
Test Procedure	1
CONSOLE INTERFACE BOARD HARNESS	2
OUTLINE DIAGRAM	3
PARTS LIST	4
SCHEMATIC DIAGRAM	5

**CONSOLE INTERFACE BOARD
(19D438451G1)**

The Console Interface board is mounted behind the analog voter and contains a 2175 Hz tone generator, a 2175 Hz tone detector, and line interfaces. This board allows routing of voted and console audio with the proper Secur-it/hold tone. A block diagram of the Console Interface board is shown in Figure 1.

The board generates and detects the 2175 Hz tone which is required to provide the dispatch console override feature in EDACS voting. In normal voter operation, 2175 Hz is generated and bridged across the voted audio phone line going to the station control panel. The tone acts as a transmit keep-alive signal which lets the station know the condition of the control link.

When the console operator wishes to preempt a transmission in progress, the console is keyed on the group transmission. The 2175 Hz tone that is superimposed on the console audio is detected by the Console Interface board, and activates the carrier-operated relay (COR) in the analog voter. This relay switches the audio lines going to the control panel.

2175 HZ TONE GENERATOR

The generator is controlled by the digital voter selector mute control line, and contains coupling to allow the same signal to control the analog voter. The generator output is typically set to -20 dBm.

The 2918 Hz tone is generated by an oscillator formed from AR3 and associated components. Amplifier AR3 and filter FL2 form a narrow bandpass filter trimmed to 2175 Hz. Output from AR3 (pin 1) is coupled through C41 and R45 to an amplifier stage formed from Q5 and Q6. Transistor Q5 provides about 6 dB gain, while emitter follower Q6 provides the necessary impedance matching. The output signal from the emitter follower is coupled back to the input bias network of AR3 through C46 and R42 to provide feedback for the oscillator.

Resistor R54 sets the 2175 Hz tone level by adjusting the gain of amplifier U4A. Output of the 2175 Hz tone generator is applied to CMOS transmission gate U1B-4. The switch is controlled by the TONE CONTROL line (J1-3) which comes from the voter selector. When this line is held low, the 2175 Hz tone is coupled through R55 and C51 to line transformer T2. This transformer is externally tied across the voted audio line through PHONE OUT (J1-1 & 2). Transient suppression is provided by E3 and E4. Resistor R68 couples the TONE CONTROL signal out J1-6 where it is used to mute the analog voter.

2175 HZ TONE DETECTOR

The detector senses the audio line coming from the console and, upon detecting a 2175 Hz tone, will control the carrier-operated relay (COR) of the analog voter. This causes console audio (in place of voter audio) to be routed to the main site. The digital voter selector also monitors the COR control line, and therefore knows when the console has preempted the line.

Audio input from the dispatch console comes through J1-9 and J1-10 (PHONE IN). Surge suppression is provided by E1 and E2. The console audio is coupled to a bandpass filter (U3A & U3B) through transformer T1. The two-pole bandpass filter has a broad bandwidth centered at 2175 Hz. This provides pre-filtering and overload protection for the high-Q filter which follows. The output from the filter is coupled through unity-gain buffer U3C which drives the active bandpass filter (AR1 and FL1). Recovered 2175 Hz from the filter is present at test point TP3.

Transistor Q2 provides a gain of three and buffers the filter output. The amplified signal is ac coupled through C10 to the base of Q3. Transistor Q3 acts as a positive-peak detector. When the base of Q3 is driven positive, the transistor conducts discharging C12 which is at a quiescent 10-volt level. During periods of non-conduction, C12 charges through R28 and R29.

At a certain level of Q3 conduction, the average voltage on C12 will be low enough to turn on Q4 through R27 and voltage divider R28/R29.

When Q4 conducts, the base of Q3 is biased higher, increasing conduction. This provides a snap-action pick up or hysteresis. One input of comparator U3D is tied through R31 to capacitor C12. The other input (U3D-12) is held at 5 volts by voltage divider R30/R32. When the voltage level on C12 drops below 5 volts, the output of the comparator (U3D-14) will go high indicating detection of 2175 Hz tone and causing the TONE DETECT (J1-04) line to go high. Inverter Q7 provides an inverted TONE DETECT signal (J1-08) that is used in some applications. Jumper P2 allows Q7 to be used as an independent inverter.

POWER DISTRIBUTION

The Console Interface board obtains 25 Vdc power from the analog voter through J1-5. The 25-volt supply feeds the input of a 10-volt linear regulator (U2). Resistors R62 and R63 bias U2 for 10-volt regulation at U2-2. The 10-volt regulated output is used to supply power to most of the circuitry on the board. A 5-volt reference is obtained from the 10-volt line through voltage divider R36/R37. The reference is used to bias op-amps U3 and U4.

TEST AND TROUBLESHOOTING

The test procedure contained in this section should be used to verify proper operation of the Console Interface board. The test may also be used as an aid in troubleshooting to isolate a problem to a stage or component.

Equipment Required

The following equipment is required for performing the test procedure.

- Power Supply, 25 ± 1 Vdc, 50 mA
- Distortion Analyzer
- Voltmeter
- Signal Generator, 2175/2460/1970 ± 3 Hz
- Frequency Counter, 2175/2460/1970 Hz
- Jumpers

Test Procedure

Set up the Console Interface board under test as shown in Figure 2. Follow the test procedure in Table 1.

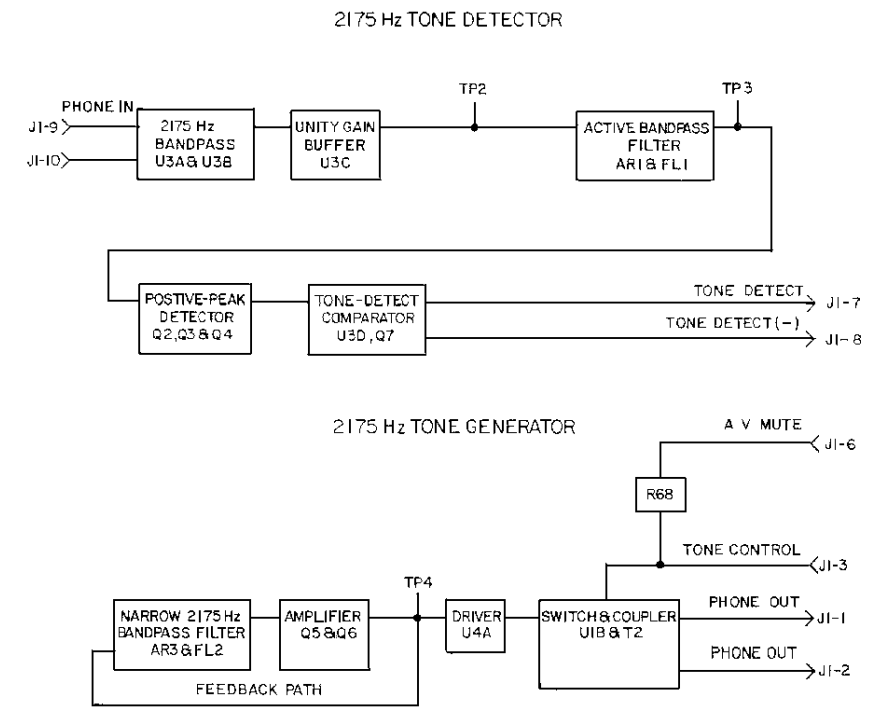

Figure 1 - Console Interface Board Block Diagram

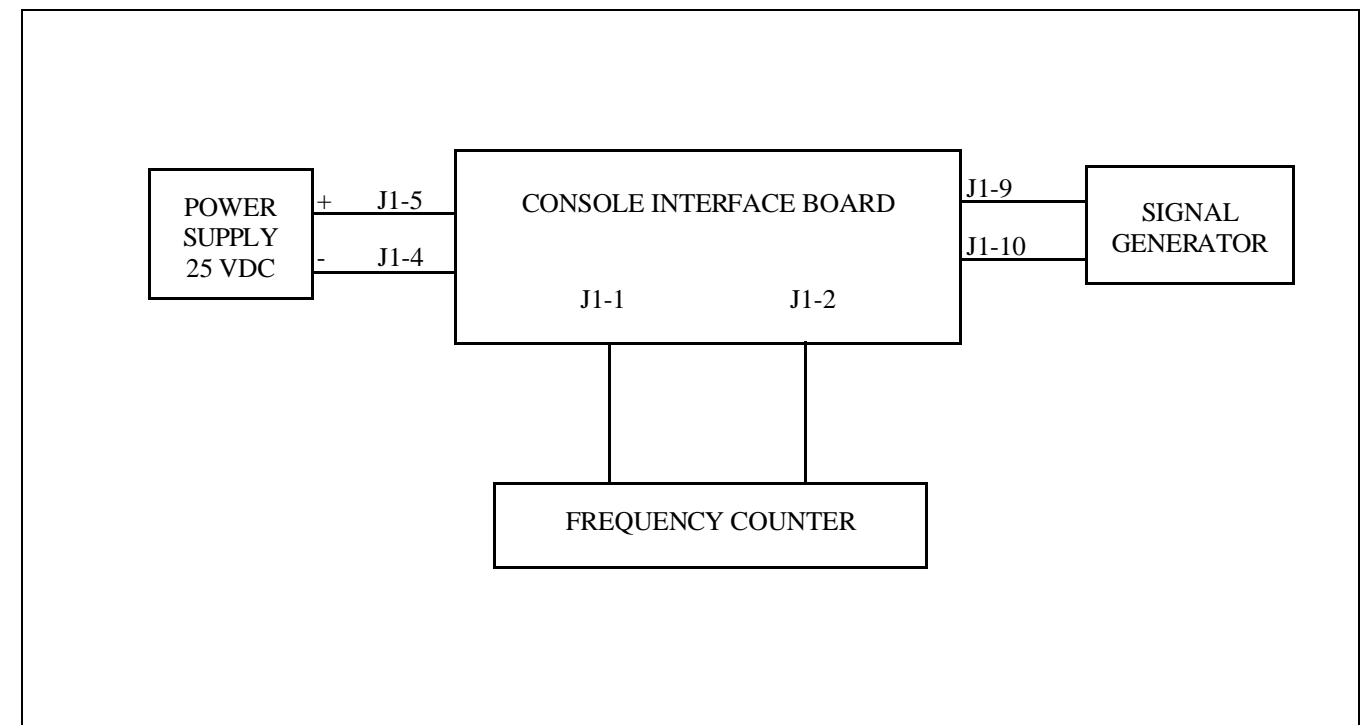
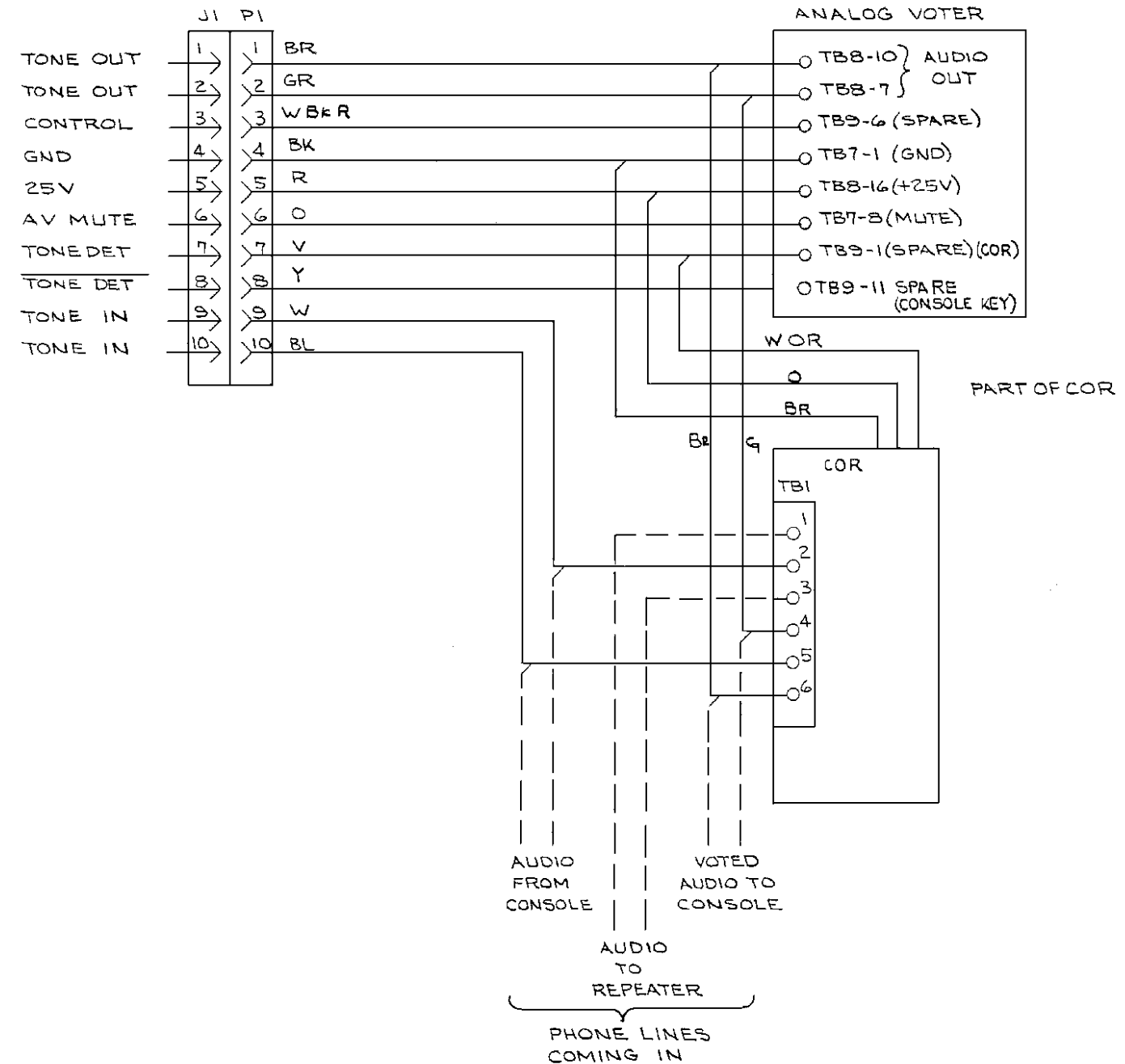

Figure 2 - Preliminary Test Set Up

Table 1 - TEST PROCEDURE

NO.	STEP	MEASUREMENT	CORRECTIVE ACTION
1.	Connect test equipment as shown in Figure 2.		
2.	Apply 25 ±1 Vdc power to the board under test.		
3.	Measure power supply current.	< 50 mA	a. Check for shorts b. Check for loading on 10 V bus.
4.	Measure the regulated voltage at U2-2.	10 ±0.3 Vdc	Check U2 and associated components.
5.	Measure the frequency of the signal across J1-1 and J1-2.	2175 ±3 Hz	a. Check for 2175 Hz at TP6. If present, check U1B, T2, and associated components. b. Check for 2175 Hz at TP4. If present, check U4A and associated components. c. Check AR3, FL2 and associated components.
6.	Adjust R54 through its range while monitoring the 2175 Hz level across J1-1 and J1-2.	< -20 thru > -10 dBm.	Check R54, R50, C45, U4A, and U1B.
7.	Monitor the 2175 Hz level across J1-1 and J1-2, and adjust R54 for -20 dBm.	-20 ± 0.2 dBm.	Check R54, R52, R50, C45, U4A, and U1B.
8.	Measure the voltage at J1-6.	> 9 Vdc	Check R68 and R58.
9.	Ground J1-3 and measure the signal level across J1-1 and J1-2.	< -60 dBm	Check U1B, T2, and associated components.
10.	Measure the voltage at J1-6.	< 0.1 Vdc	Check the resistor R68.
11.	Apply a 2175 ± 3 Hz tone at a -40 dBm level across J1-9 and J1-10.		
12.	Measure the voltage at J1-7.	> 7 Vdc	Check jumper P2, R69, U3D, and detector circuit components.
13.	Measure the voltage at J1-8.	< 0.5 Vdc	Check jumper P2, Q7, and associated components.
14.	Decrease the 2175 Hz tone level to -70 dBm.		
15.	Measure the voltage at J1-8.	< 0.5 Vdc	Check Q2, Q3, Q4, U3D, and associated components of detector circuit.
16.	Measure the voltage at J1-8.	> 7 Vdc	Check Q7 and associated components.
17.	Change the signal generator frequency to 2460 ±5 Hz at -20 dBm.		
18.	Measure the voltage at J1-7.	< 0.5 Vdc	a. Check U3A, U3B, U3C, and associated components. b. Check AR1, FL1, Q2, and associated components. c. Check U3D and associated components.
19.	Change the signal generator frequency to 1970 ±5 Hz.		
20.	Measure the voltage at J1-7.	< 0.5 Vdc	a. Check U3A, U3B, U3C, and associated components. b. Check AR1, FL1, Q2, and associated components. c. Check U3D and associated components.



(19C336922, Sh. 1, Rev. 0)

COMPONENT SIDE

SOLDER SIDE

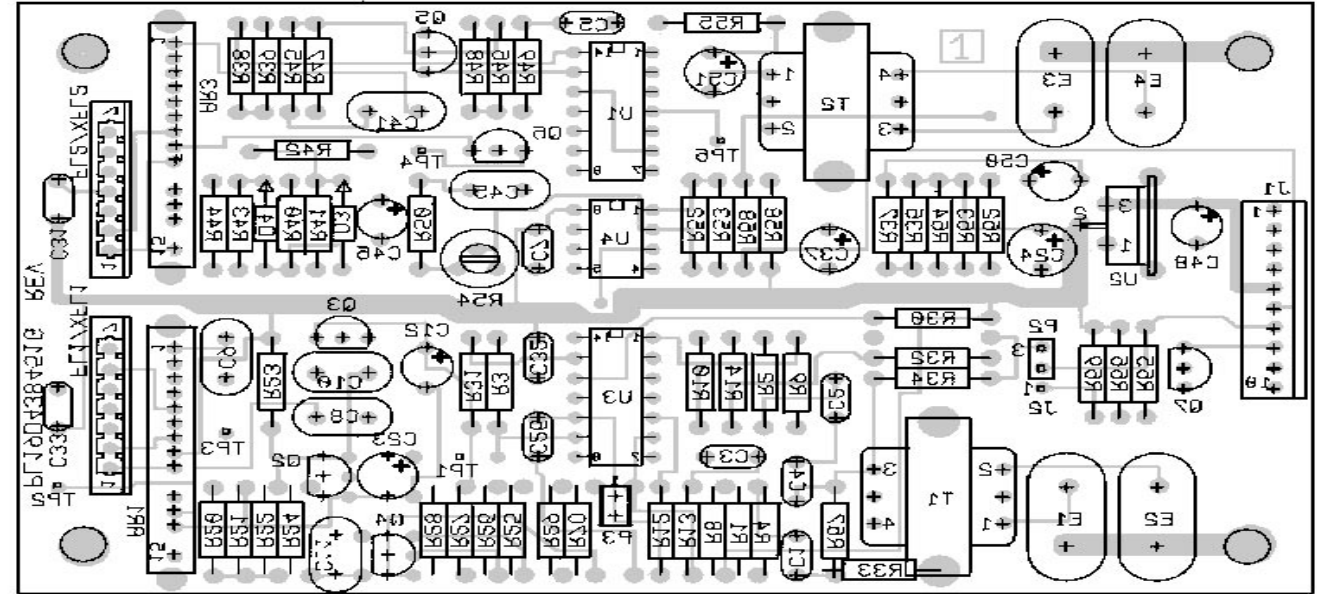
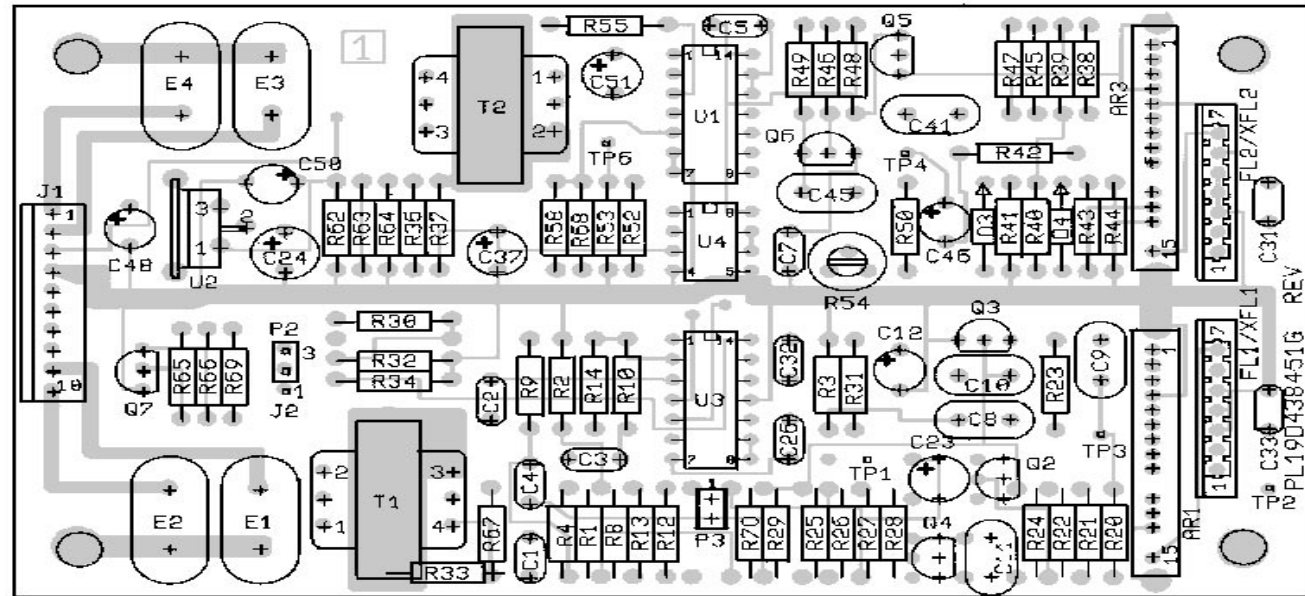

(19D438450, Rev. 1)

(19D438450, Rev. 1)

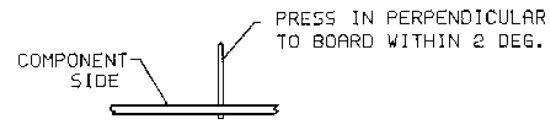

TYPICAL MOUNTING FOR J2, TP1 THRU TP4, & TP6

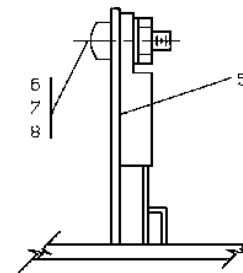
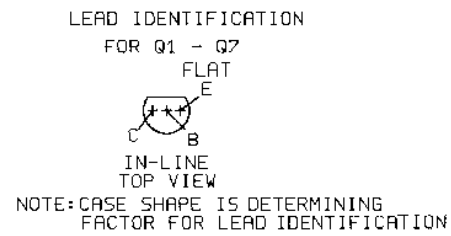

TYPICAL MOUNTING FOR U4 LEAD FORM PER 19A70129



CAUTION
OBSERVE PRECAUTIONS FOR HANDLING ELECTROSTATIC SENSITIVE DEVICES

(19D438451, Sh. 1, Rev. 3)

PRODUCTION CHANGES

Changes in the equipment performance or to simplify circuits are identified by a "Revision Letter", which is stamped after the model number of the unit. The revision stamped on the unit includes all previous revisions. Refer to the Parts List for the descriptions of parts affected by these revisions.

REV. A - Console Interface Board 19D438451G1

To improve tone detection, capacitor C12 was changed from 0.1 µF to µF.

Old part number was: T644ACP410K.

REV. B - Console Interface Board 19D438451G1

In some applications, the main level on the line input from the switch may cause the COR of the analog voter to chatter. A jumper option is provided to allow a gain reduction of 10 dB.
R70 was added (H212CRP315C).
P3 was added (19A704852P1).

CONSOLE INTERFACE BOARD
19D438451G1
ISSUE 3

SYMBOL	GE PART NO.	DESCRIPTION
----- INTEGRATED CIRCUITS -----		
AR1 and AR3	19D417092G2	Selective Amplifier.
----- CAPACITORS -----		
C1 and C2	T644ACP310J	Polyester: .010 µF ±5%, 50 VDCW.
C3	T644ACP310K	Polyester: .010 µF ±10%, 50 VDCW.
C4	T644ACP310J	Polyester: .010 µF ±5%, 50 VDCW.
C5	T644ACP310K	Polyester: .010 µF ±10%, 50 VDCW.
C7	T644ACP310K	Polyester: .010 µF ±10%, 50 VDCW.
C8 thru C11	T644ACP410K	Polyester: 0.1 µF ±10%, 50 VDCW.
C12*	19A701534P4	Tantalum: 1 µF ±20%, 35 VDCW.
C23	19A701534P15	Tantalum: 3.3 µF ±20%, 35 VDCW.
C24	19A701534P8	Tantalum: 22 µF ±20%, 16 VDCW.
C26	T644ACP310K	Polyester: .010 µF ±10%, 50 VDCW.
C31 thru C33	T644ACP310K	Polyester: .010 µF ±10%, 50 VDCW.
C37	19A701534P6	Tantalum: 4.7 µF ±20%, 35 VDCW.
C41	T644ACP410K	Polyester: 0.1 µF ±10%, 50 VDCW.
C45	T644ACP410K	Polyester: 0.1 µF ±10%, 50 VDCW.
C46	19A701534P4	Tantalum: 1 µF ±20%, 35 VDCW.
C48	19A701534P4	Tantalum: 1 µF ±20%, 35 VDCW.
C50	19A701534P4	Tantalum: 1 µF ±20%, 35 VDCW.
C51	19A701534P15	Tantalum: 3.3 µF ±20%, 35 VDCW.
----- DIODES -----		
D3 and D4	19A115250P1	Silicon, fast recovery, 225 mA, 50 PIV.
----- TERMINALS -----		
E1 thru E4	19A705677P1	Contact, electrical.
----- FILTERS -----		
FL1 and FL2	19C320291G17	Hybrid Network.
----- JACKS -----		
J1	19A704852P36	Printed wire, two part: 10 contacts, sim to Molex 22-29-2101.
J2	19A703248P11	Post: Gold Plated, 10 mm length.
----- PLUGS -----		
P2	19A702104P2	Connector: Shorting Jumper, Gold Plated. (Housing Color: White).
P3*	19A704852P1	Printed wire, two part: 2 contacts; sim to Molex 22-10-2021.
----- TRANSISTORS -----		
Q2 and Q3	19A700023P2	Silicon, NPN: sim to 2N3904.
Q4	19A700022P2	Silicon, PNP: sim to 2N3906.
Q5 thru Q7	19A700023P2	Silicon, NPN: sim to 2N3904.

*COMPONENTS ADDED, DELETED OR CHANGED BY PRODUCTION CHANGES

SYMBOL	GE PART NO.	DESCRIPTION
----- RESISTORS -----		
R1	19A701250P390	Metal film: 84.5K ohms ±1%, 1/4 w.
R2	19A701250P289	Metal film: 8.25K ohms ±1%, 250 VDCW, 1/4 w.
R3	H212CRP247C	Deposited carbon: 4.7K ohms ±5%, 1/4 w.
R4	19A701250P288	Metal film: 8060 ohms ±1%, 250 VDCW, 1/4 w.
R8	H212CRP322C	Deposited carbon: 22K ohms ±5%, 1/4 w.
R9	19A701250P279	Metal Film: 6.49K ohms ±1%, 1/4 w.
R10	19A701250P237	Metal film: 7.37K ohms ±1%, 1/4 w.
R12	H212CRP333C	Deposited carbon: 33K ohms ±5%, 1/4 w.
R13	H212CRP347C	Deposited carbon: 47K ohms ±5%, 1/4 w.
R14	19A701250P201	Metal film: 1K ohms ±1%, 250 VDCW, 1/4 w.
R20	19A701250P356	Metal film: 37.4K ohms ±1%, 1/4 w.
R21	19A701250P418	Metal film: 150K ohms ±1%, 1/4 w.
R22	H212CRP415C	Deposited carbon: 0.15M ohms ±5%, 1/4 w.
R23	H212CRP322C	Deposited carbon: 22K ohms ±5%, 1/4 w.
R24 and R25	H212CRP410C	Deposited carbon: 100K ohms ±5%, 1/4 w.
R26	H212CRP527C	Deposited carbon: 2.7M ohms ±10%, 1/4 w.
R27	H212CRP310C	Deposited carbon: 10K ohms ±5%, 1/4 w.
R28	H212CRP382C	Deposited carbon: 82K ohms ±5%, 1/4 w.
R29	H212CRP322C	Deposited carbon: 22K ohms ±5%, 1/4 w.
R30 thru R32	H212CRP347C	Deposited carbon: 47K ohms ±5%, 1/4 w.
R33	H212CRP468C	Deposited carbon: 0.68M ohms ±5%, 1/4 w.
R34	H212CRP310C	Deposited carbon: 10K ohms ±5%, 1/4 w.
R36 and R37	H212CRP310C	Deposited carbon: 10K ohms ±5%, 1/4 w.
R38	19A701250P301	Metal film: 10K ohms ±1%, 1/4 w.
R39	19A701250P330	Metal film: 20K ohms ±1%, 1/4 w.
R40	19A701250P451	Metal film: 332K ohms ±1%, 250 VDCW, 1/4 w.
R41 and R42	19A701250P318	Metal film: 15K ohms ±1%, 1/4 w.
R43	19A701250P285	Metal film: 7.5K ohms ±1%, 250 VDCW, 1/4 w.
R44	19A701250P281	Metal film: 6.81K ohms ±1%, 1/4 w.
R45	19A701250P393	Metal film: 90.9K ohms ±1%, 250 VDCW, 1/4 w.
R46	H212CRP415C	Deposited carbon: 0.15M ohms ±5%, 1/4 w.
R47	H212CRP322C	Deposited carbon: 22K ohms ±5%, 1/4 w.
R48	H212CRP347C	Deposited carbon: 47K ohms ±5%, 1/4 w.
R49	H212CRP251C	Deposited carbon: 5.1K ohms ±5%, 1/4 w.
R50	H212CRP222C	Deposited carbon: 2.2K ohms ±5%, 1/4 w.
R52	H212CRP227C	Deposited carbon: 2.7K ohms ±5%, 1/4 w.
R53	H212CRP251C	Deposited carbon: 5.1K ohms ±5%, 1/4 w.
R54	19A700016P6	Variable, cermet: 50K ohms ±10%, 1/2 w; sim to Bourns 3329H-1-503.
R55	H212CRP212C	Deposited carbon: 1.2K ohms ±5%, 1/4 w.
R58	H212CRP215C	Deposited carbon: 1.5K ohms ±5%, 1/4 w.
R62	19A701250P223	Metal film: 1.69K ohms ±1%, 1/4 w.
R63	19A701250P138	Metal film: 243 ohms ±1%, 250 VDCW, 1/4 w.
R64	H212CRP222C	Deposited carbon: 2.2K ohms ±5%, 1/4 w.
R65	H212CRP310C	Deposited carbon: 10K ohms ±5%, 1/4 w.
R66	H212CRP347C	Deposited carbon: 47K ohms ±5%, 1/4 w.
R67	H212CRP212C	Deposited carbon: 1.2K ohms ±5%, 1/4 w.
R68	H212CRP315C	Deposited carbon: 15K ohms ±5%, 1/4 w.
R69	H212CRP310C	Deposited carbon: 10K ohms ±5%, 1/4 w.
R70*	H212CRP315C	Deposited carbon: 15K ohms ±5%, 1/4 w.
----- TRANSFORMERS -----		
T1 and T2	19A705720P1	Transformer, audio.

SYMBOL	GE PART NO.	DESCRIPTION
----- TEST POINTS -----		
TP1 thru TP4	19A703248P11	Post: Gold Plated, 10 mm length.
TP6	19A703248P11	Post: Gold Plated, 10 mm length.
----- INTEGRATED CIRCUITS -----		
U1	19A700029P44	Digital: BILATERAL SWITCH.
U2	19A701999P1	Linear: Voltage Regulator; sim to LM317T.
U3	19A701789P1	Linear: Quad Op Amp; sim to LM324.
U4	19A701789P2	Linear: Dual Op Amp; sim to LM358.
----- SOCKETS -----		
XF11 and XF12	19C320299G1	Connector. Includes: 19D416714P1 Shell, 19B219681P1 Contact, electrical.
----- MISCELLANEOUS -----		
	19B232901P2	Support.
	NS0P9005B6	Machine screw: pan head, steel.
	N404P1B6	Lockwasher; internal: No. 4.
	7141225P2	Nut, Hex: 4-40.

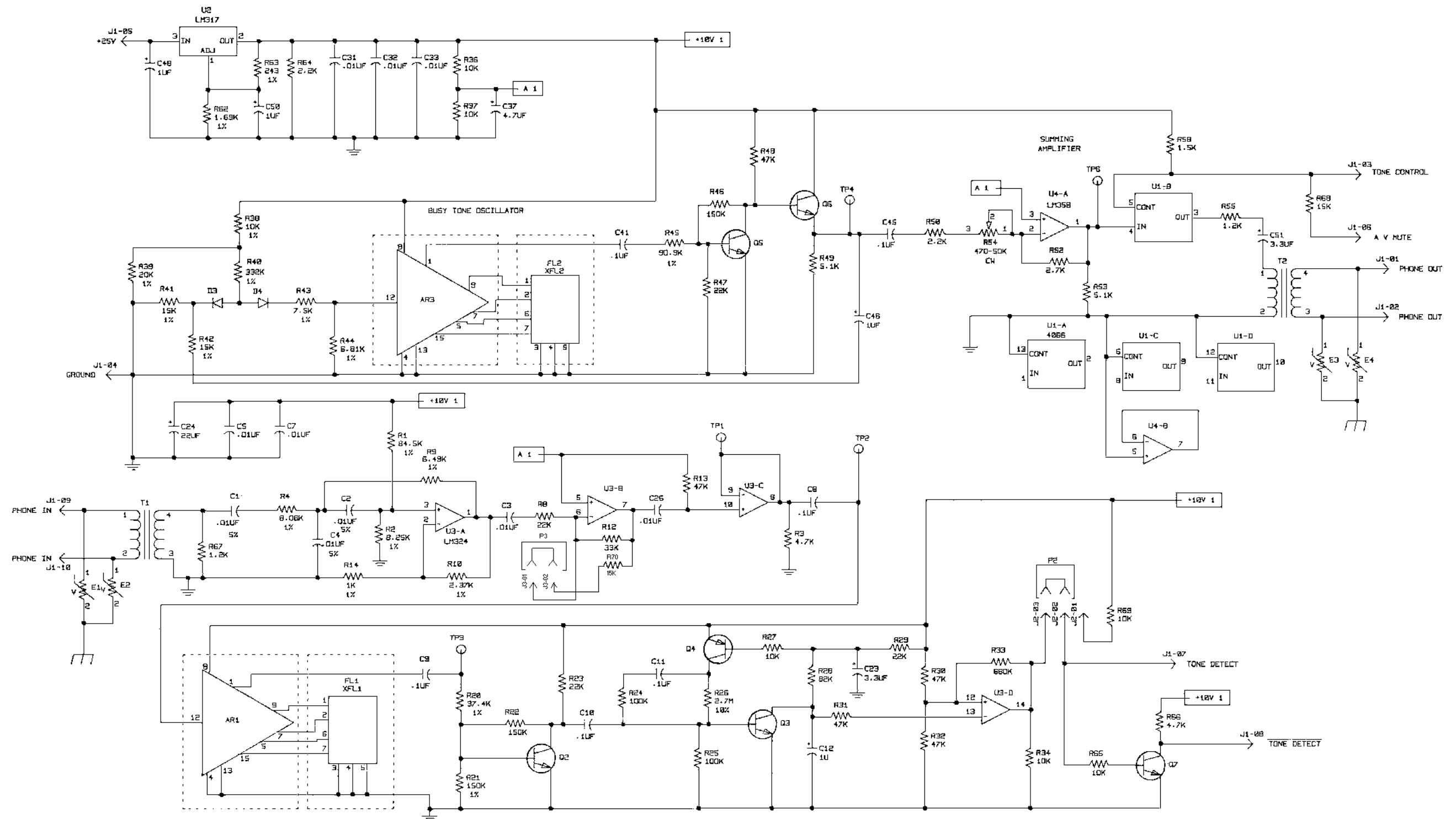

POWER & GROUND CONNECTIONS

DEVICE	+18V PIN NO.	GND PIN NO.
U1	14	7
U3	4	11
U4	8	4

ALL RESISTORS ARE 1/4 WATT UNLESS OTHERWISE SPECIFIED AND RESISTOR VALUES IN OHMS UNLESS FOLLOWED BY K=1000 OHMS OR MEG=1,000,000 OHMS. CAPACITOR VALUES IN PICOFARADS (EQUAL TO MICROMICROFARADS) UNLESS FOLLOWED BY UF=MICROFARADS. INDUCTANCE VALUES IN MILLIHENRYS UNLESS FOLLOWED BY M= MILLIHENRYS OR H=HENRYS.

MODEL NO	REV LETTER
PL19D43845IG1	B

UNLESS OTHERWISE SPECIFIED:
 ALL POLARIZED CAPACITORS ARE +/- 20%
 ALL OTHER CAPACITORS ARE +/- 10%
 ALL RESISTORS ARE +/- 5%