

M-RK I

PERSONAL RADIO

DISASSEMBLY AND ASSEMBLY PROCEDURE

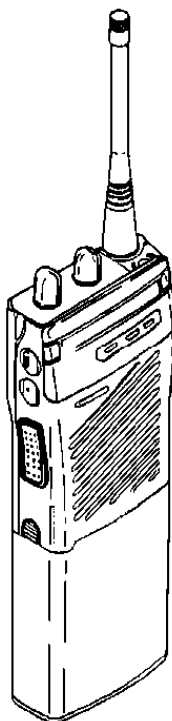

● CAUTION - BEFORE PROCEEDING -

1. Please read this booklet carefully before carrying out procedures.
2. After reading, keep it somewhere convenient for reference.
3. Always remove BATTERY PACK before procedure, as it may cause a power short.
(See page 2 "1. BATTERY PACK REMOVAL".)
4. Do not follow any procedures other than what is shown in this booklet as it may cause the main unit to malfunction.

● Necessary Tools

- The following tools are necessary for assembly and disassembly.
 - TORX screwdriver (T-8)
 - Screwdriver (M2)
 - Torque wrench with adapters

1. M-RK I DISASSEMBLY

1. BATTERY PACK REMOVAL

1. Make sure that the VOLUME SWITCH is turned off.
2. Release the BATTERY LATCH by pushing it up in the direction of Arrow 1.
3. Remove the BATTERY PACK by sliding it in the direction of Arrow 2.

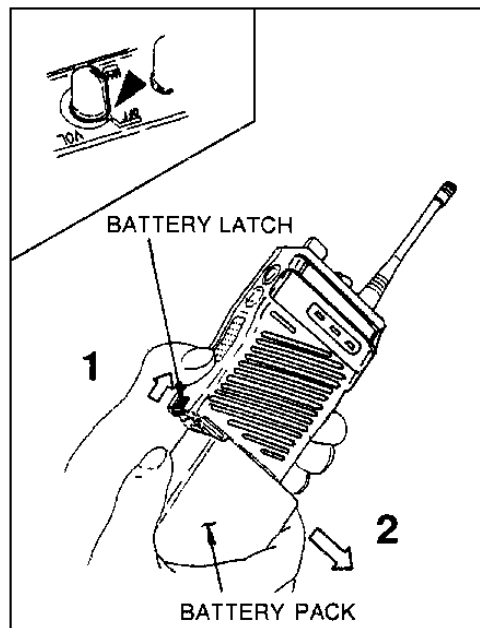

2. REAR CASE REMOVAL

1. Loosen the four captive screws (TORX BIND, M2.6X6) on the REAR CASE with the TORX screwdriver (T-8) and remove the REAR CASE.

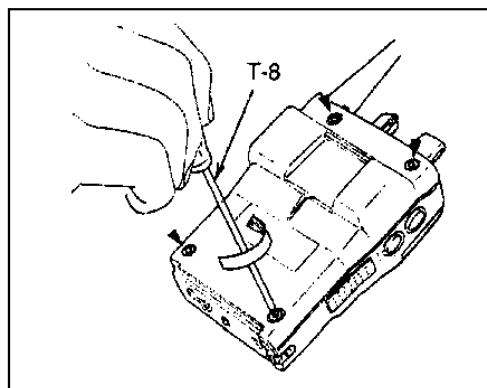

3. INTERNAL UNIT REMOVAL

1. Remove the REAR CASE, and loosen the two flat screws (M3) on the bottom of the main unit with the screwdriver.

2. Gently pull the loosened screws fully.

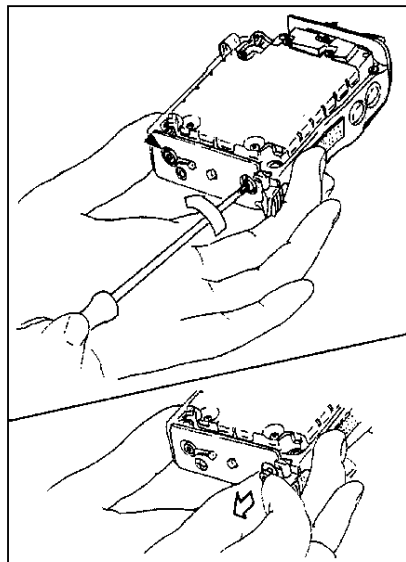

3. Loosen the two screws (PANHEAD, M2X6) on both sides at the upper part with the screwdriver and remove them.

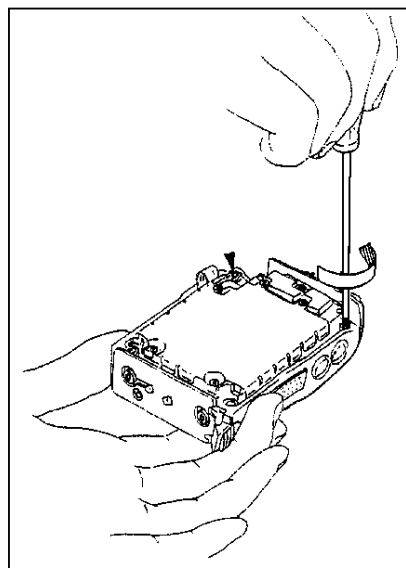

Note: For REARCASE removal, see page 2 "2. REAR CASE REMOVAL."

4. Separate the INTERNAL UNIT from the FRONT CASE. First, disengage the bottom part of INTERNAL UNIT as shown, taking care not to damage the fitting between the TOP PANEL and the FRONT CASE.

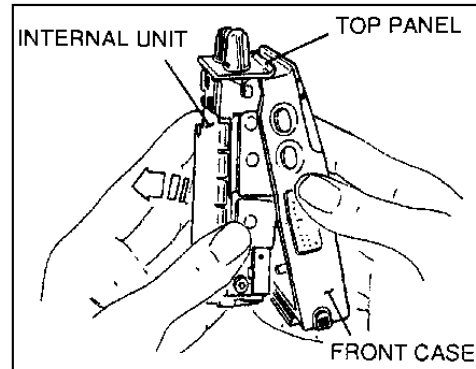

5. Remove the INTERNAL UNIT from the FRONT CASE being careful not to damage the FLEX P.C.B.

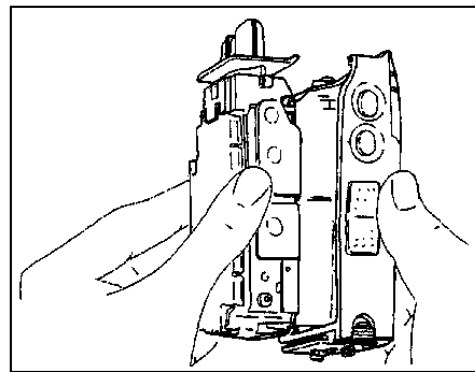

6. Disconnect the CONNECTOR A with a flat tipped tool.

Note: Pull the CONNECTOR A straight out being careful not to damage the connector pins.

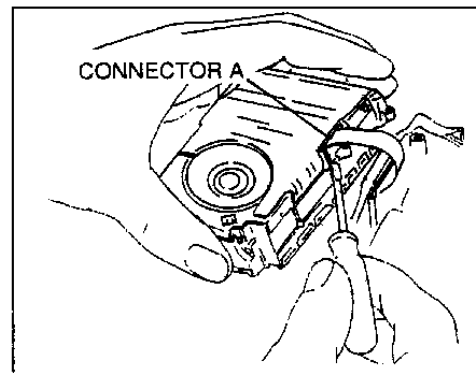

4. LED FLEX ASSY. REMOVAL

1. Loosen the screw (BTP, M2X3.5) on the back of the LED FLEX ASSY. with the screwdriver and remove it.

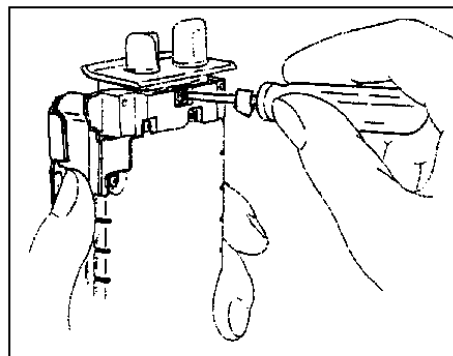

2. Loosen the two screws (PANHEAD, M2X2) on both sides of the LED FLEX ASSY. with the screwdriver and remove them.

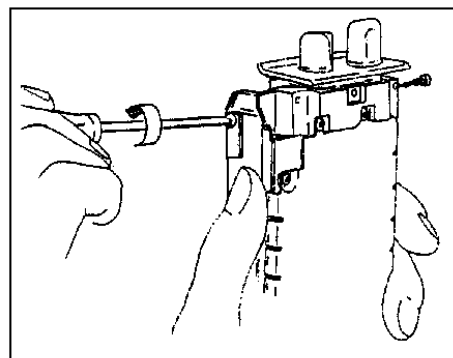

3. Insert a flat tipped tool into the frame of the CONNECTOR B as shown, and lift up the CONNECTOR B slightly to disengage the fitting.

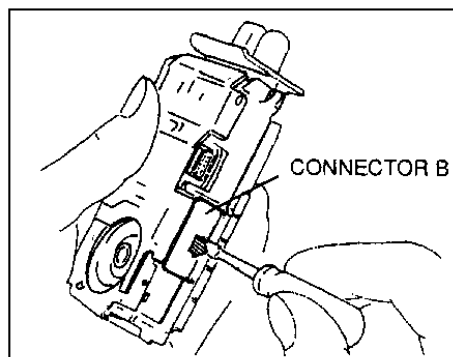

4. Hold the CONNECTOR B with your fingers and remove it taking care not to damage the connector pins.

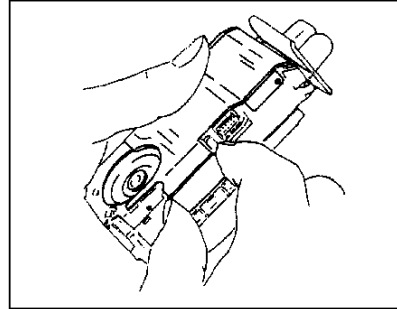

5. Insert a tool with thin end such as a minus screwdriver at the fitting between the LED FLEX ASSY. and the protruding part of the CHASSIS. Then disengage the fitting by twisting the tool, and remove the LED FLEX ASSY. gently.

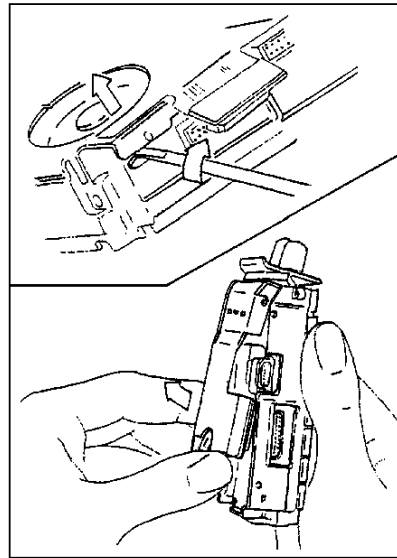

5. RF BOARD ASSY. AND CONTROL BOARD ASSY. REMOVAL

1. Loosen the two screws (PANHEAD, M2X2) at the upper part of the RF SHIELD PLATE with the screwdriver and remove them.

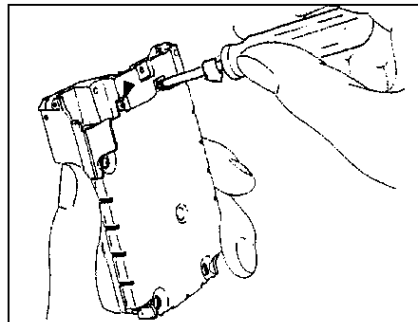

2. Remove the three screws (PANHEAD, M2X4 with SW) at the indented parts of the RF SHIELD PLATE, and remove the RF SHIELD PLATE.

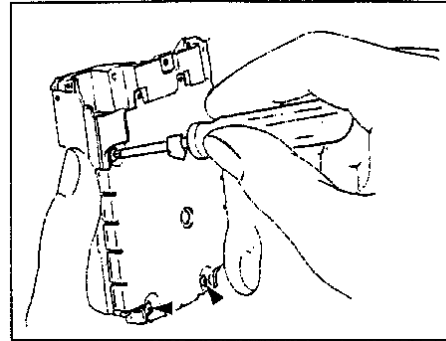

3. Remove the two screws (BIND, M2.6X6) on the side of the CASTING with the screwdriver and remove the PA MODULE RETAINER.

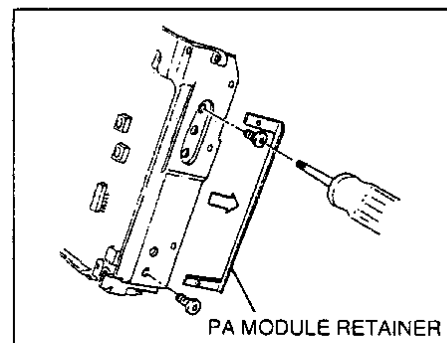

4. Lift up the RF BOARD ASSY. taking care not to damage the connector which connects it with the CONTROL BOARD ASSY. Then remove the RF BOARD ASSY. from the CASTING keeping horizontal state.

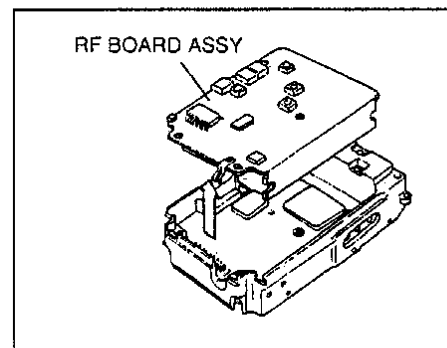

Note: The connector is located on the bottom of the CASTING as shown.

5. Turn the CASTING over and loosen the three screws (PANHEAD with SW, M2X4) on the CONTROL BOARD ASSY. with the screwdriver, and remove the CONTROL BOARD ASSY. from the CASTING.

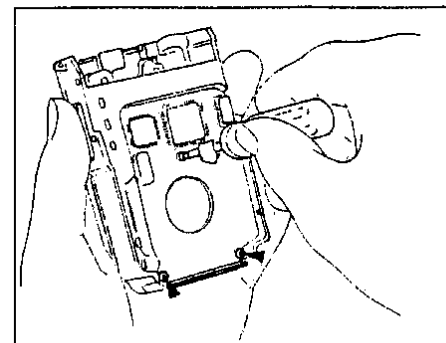

2. M-RK I ASSEMBLY

1. INTERNAL UNIT ASSEMBLY

1. Put the mounting holes on the RF BOARD ASSY. and the bosses at the mounting holes on the CASTING together, and fit the RF BOARD ASSY. with the CASTING.

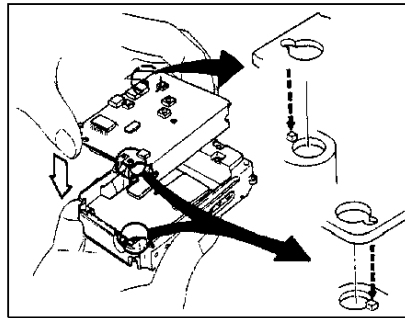

2. Install the RF SHIELD PLATE on the CASTING by fastening the three screws (PANHEAD with SW, M2X4) at the concave parts through the RF BOARD ASSY. with the screwdriver. Torque to 1.5 kg-cm \pm 10%.

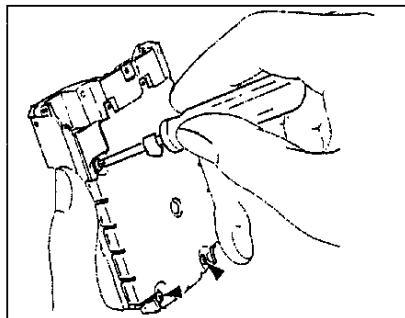

3. Secure the RF SHIELD PLATE by fastening the two screws (PANHEAD, M2X2) on the upper part with the screwdriver. Torque to 1.5 kg-cm \pm 10%.

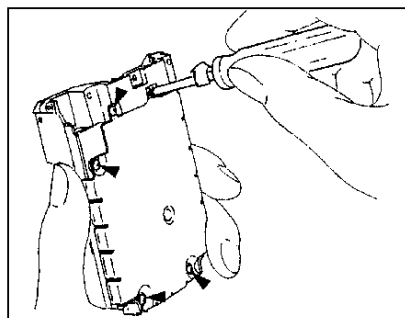

4. Insert the PA MODULE RETAINER into mounting holes and secure it by fastening the two screws (BIND, M2.6X6) on the side of the CASTING with the screwdriver. Torque to 3.6 kg-cm \pm 10%.

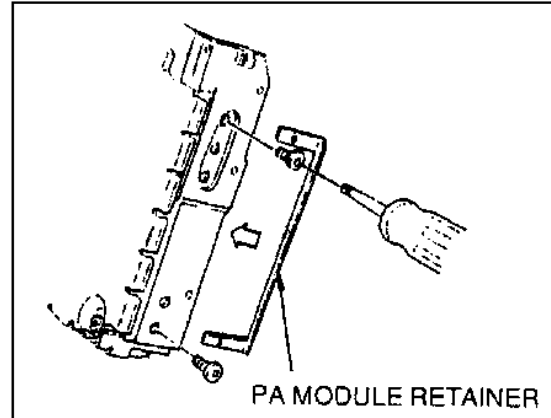

5. Turn the CASTING over and fit the connectors of the RF BOARD ASSY. and the CONTROL BOARD ASSY.

Note: Be careful not to damage the connector pins.

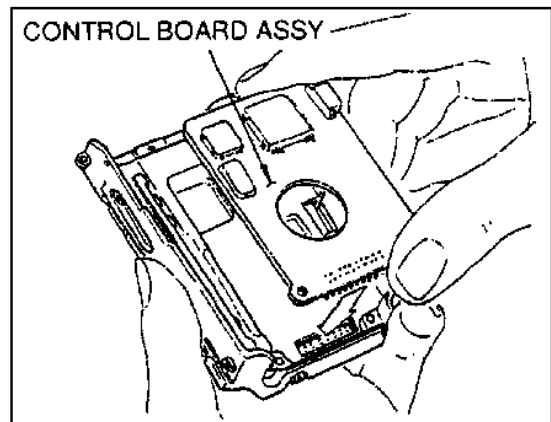

6. Secure the CONTROL BOARD ASSY. in the CASTING by fastening the three screws (PAN-HEAD with the SW, M2X4) with the screwdriver. Torque to 1.5 kg-cm \pm 10%.

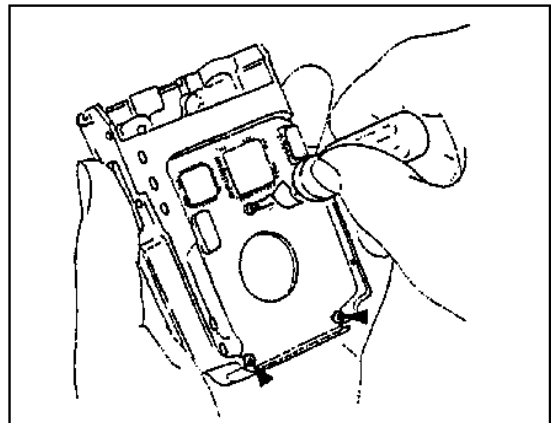

2. LED FLEX ASSY. INSTALLATION

1. Engage the upper part of the LED FLEX ASSY. with the CASTING. First fit the CHANNEL SWITCH side, then fit the EMERGENCY BUTTON SIDE.

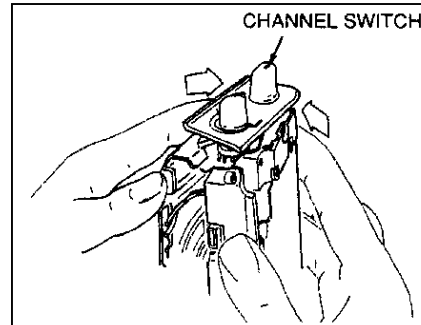

2. After engaging the upper part, fit the bosses of the LOGIC SHIELD PLATE with the holes on both sides of the CASTING.

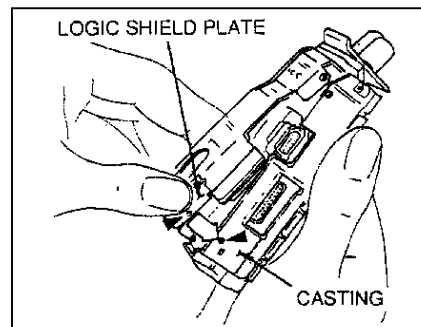

3. Fasten the screw (BTP, M2X3.5) on the upper part of the LED FLEX ASSY. with the screwdriver. Torque to 1.5 kg-cm \pm 10%.

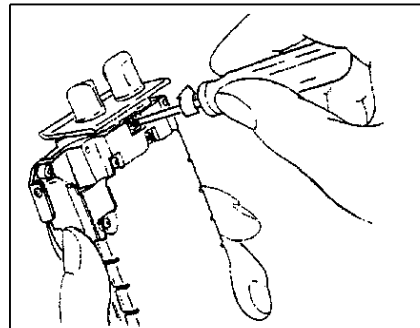

4. Secure the LED FLEX ASSY. by fastening the two screws (PANHEAD, M2X2) on both sides with the screwdriver. Torque to 1.5 kg-cm \pm 10%.

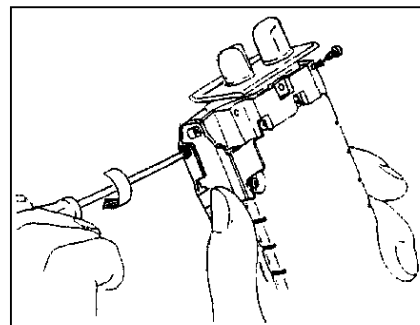

5. Fit the CONNECTOR B securely by pressing the FLEX P.C.B. on the CONNECTOR B with the thumb tip as shown.

Note: Be careful not to damage the connector pins.

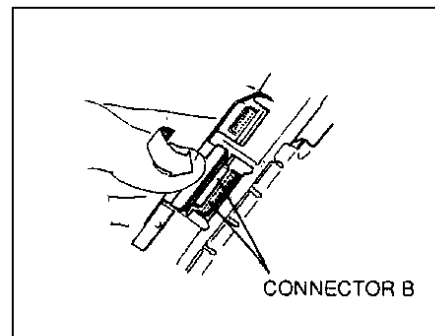

6. Hold the FLEX P.C.B. of the CONNECTOR A with your fingers, and connect by pressing the FLEX P.C.B. with the index finger tip as shown.

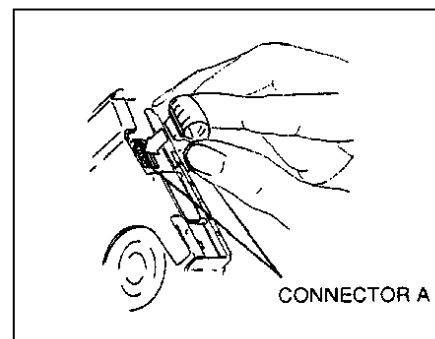

3. INTERNAL UNIT INSTALLATION

1. Place the upper part of the INTERNAL UNIT in the FRONT CASE. After deciding the position, install the INTERNAL UNIT in the FRONT CASE as shown. Then, set two screws (TORX, M3) at the bottom of the FRONT CASE.

Note: Be careful not to catch the FLEX P.C.B. of the CONNECTOR A between the FRONT CASE and the INTERNAL UNIT.

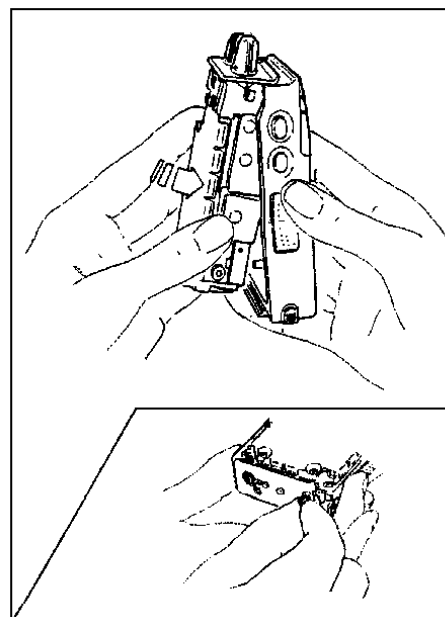

2. Secure the INTERNAL UNIT by fastening the two screws (PANHEAD, M2X6) at the upper part on both sides with the screwdriver. Torque to 1.5 kg-cm \pm 10%.

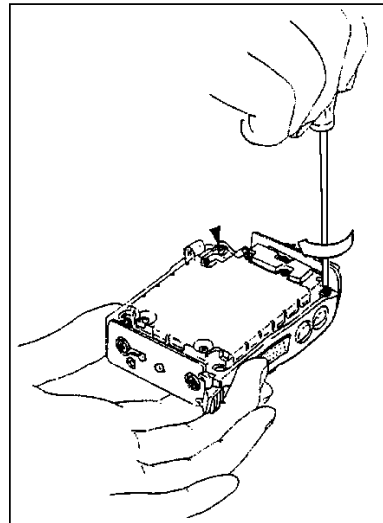

3. Fasten the two flat screws (M3) on the bottom of the FRONT CASE with the screwdriver. Torque to 5.5 kg-cm \pm 10%.

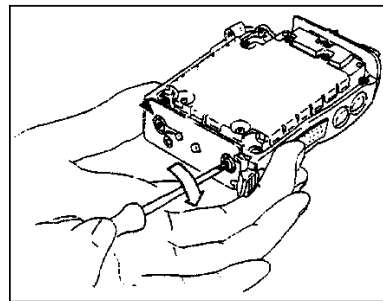

Note: After tightening screw, return the negative (-) battery contact (on the left side of diagram) just a little bit counterclockwise so the the contact is centered in the mounting groove.

4. REAR CASE INSTALLATION

1. Install the REAR CASE and fasten the four captive screws (TORX BIND, M2.6X6) with the TORX screwdriver (T-8). Take care not to catch the FLEX P.C.B. of the CONNECTOR A between the REAR CASE and the FRONT CASE.

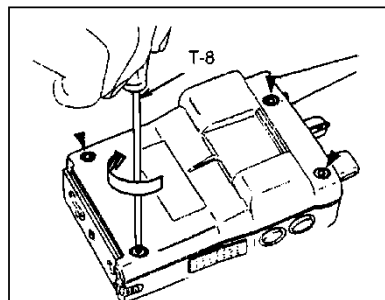

Note: Fastening torque should not be over 3.5 kg-cm.

SECTION II

M-RK II
PERSONAL RADIO

DISASSEMBLY AND ASSEMBLY PROCEDURE

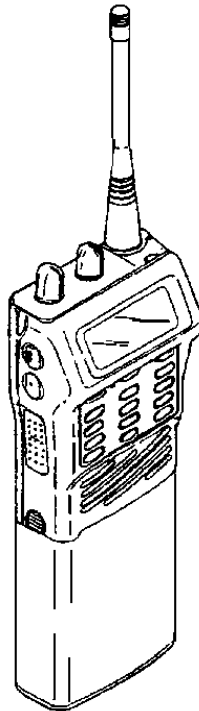
**● CAUTION - BEFORE PROCEEDING -**

1. Please read this booklet carefully before carrying out procedures.
2. After reading, keep it somewhere convenient for reference.
3. Always remove BATTERY PACK before procedure, as it may cause a power short.
(See page 14 "1. BATTERY PACK REMOVAL".)
4. Do not follow any procedures other than what is shown in this booklet as it may cause the main unit to malfunction.

● Necessary Tools

- The following tools are necessary for assembly and disassembly.
 - TORX screwdriver (T-8)
 - Screwdriver (M2)
 - Torque wrench with adapters

1. M-RK II DISASSEMBLY

1. BATTERY PACK REMOVAL

1. Make sure that the VOLUME SWITCH is turned off.
2. Release the BATTERY LATCH by pushing it up in the direction of Arrow 1.
3. Remove the BATTERY PACK by sliding it in the direction of Arrow 2.

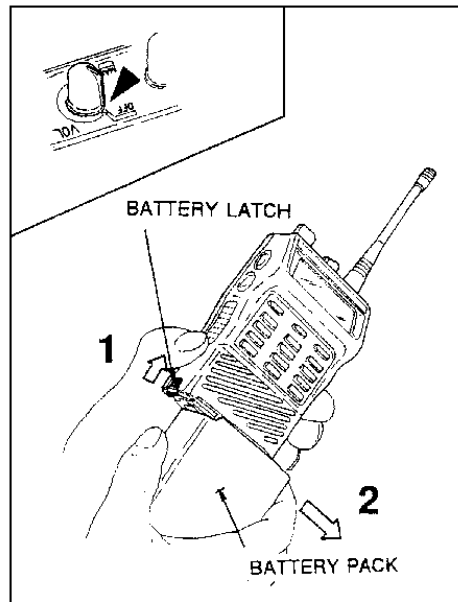

2. REAR CASE REMOVAL

1. Loosen the four captive screws (TORX BIND, M2.6X6) on the REAR CASE with the TORX screwdriver (T-8) and remove the REAR CASE.

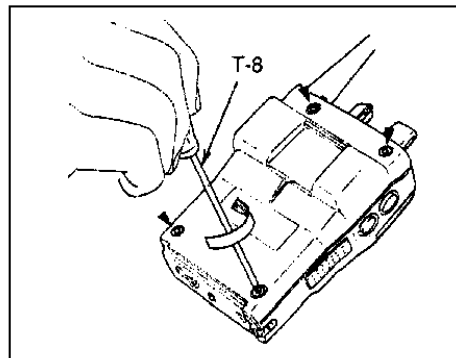

3. INTERNAL UNIT REMOVAL

1. Remove the REAR CASE, and loosen the two flat screws (M3) on the bottom of the main unit with the screwdriver.

2. Gently pull the loosened screws fully.

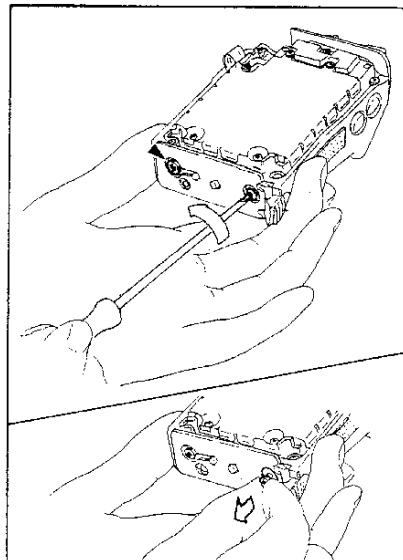

3. Loosen the two screws (PANHEAD, M2X6) on both sides at the upper part with the screwdriver and remove them.

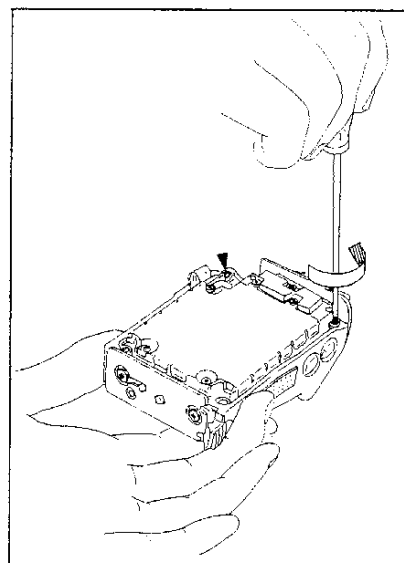

Note: For REAR CASE removal, see page 14 "2. REAR CASE REMOVAL."

4. Separate the INTERNAL UNIT from the FRONT CASE. First, disengage the bottom part of INTERNAL UNIT as shown, taking care not to damage the fitting between the TOP PANEL and the FRONT CASE.

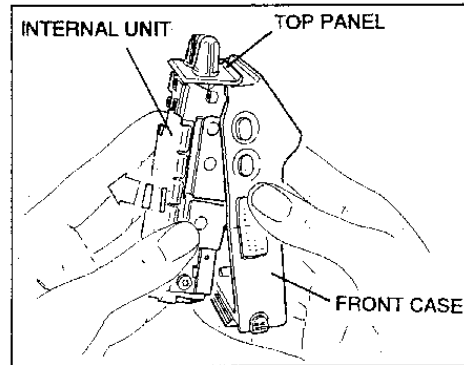

5. Remove the INTERNAL UNIT from the FRONT CASE being careful not to damage the FLEX P.C.B.

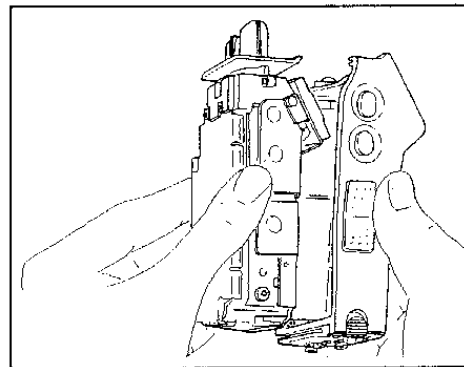

6. Disconnect the CONNECTOR A with a flat tipped tool.

Note: Pull the CONNECTOR A straight out being careful not to damage the connector pins.

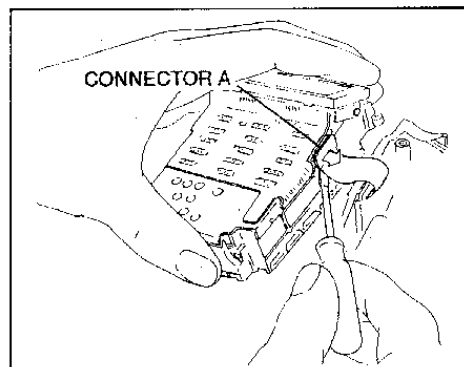

4. LCD/KB FLEX ASSY. REMOVAL

1. Loosen the screw (BTP, M2X3.5) on the back of the LCD/KB FLEX ASSY. with the screwdriver and remove it.

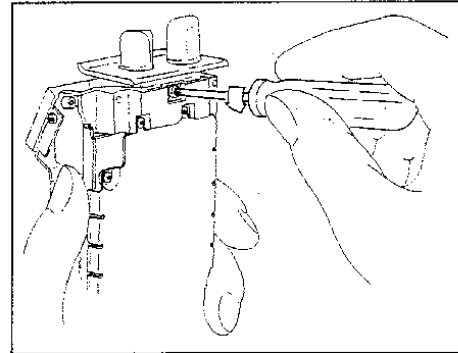

2. Loosen the two screws (PANHEAD, M2X2) on both sides of the LCD/KB FLEX ASSY. with the screwdriver and remove them.

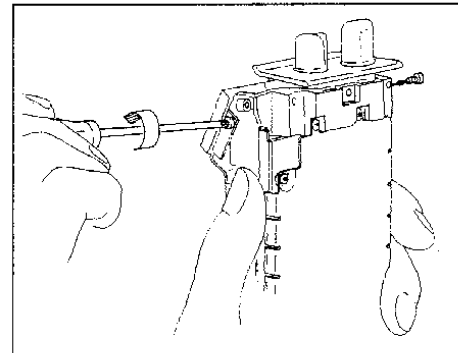

3. Insert a flat tipped tool into the frame of the CONNECTOR B as shown, and lift up the CONNECTOR B slightly to disengage the fitting.

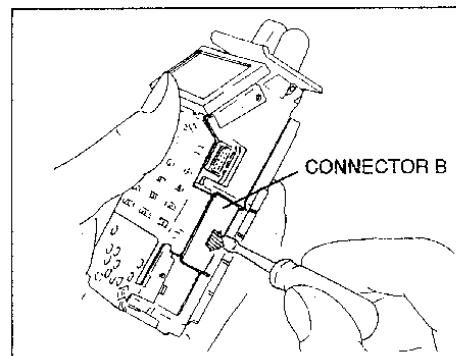

4. Hold the CONNECTOR B with your fingers and remove it taking care not to damage the connector pins.

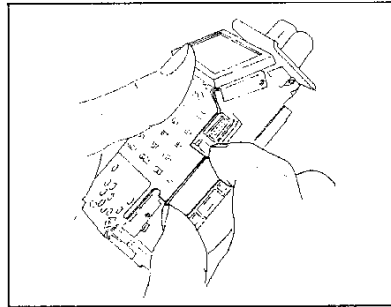

5. Insert a tool with thin end such as a minus screwdriver at the fitting between the LCD/KB FLEX ASSY. and the protruding part of the CHASSIS. Then disengage the fitting by twisting the tool, and remove the LCD/KB FLEX ASSY. gently.

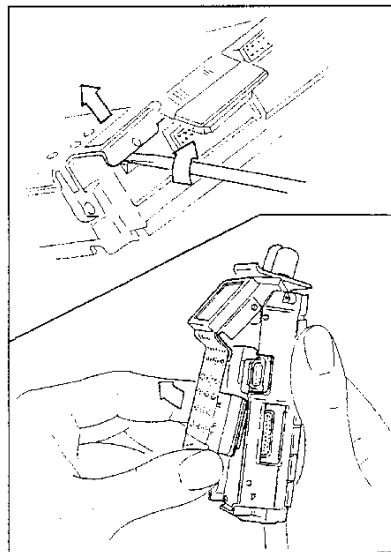

5. RF BOARD ASSY. AND CONTROL BOARD ASSY. REMOVAL

1. Loosen the two screws (PANHEAD, M2X2) at the upper part of the RF SHIELD PLATE with the screwdriver and remove them.

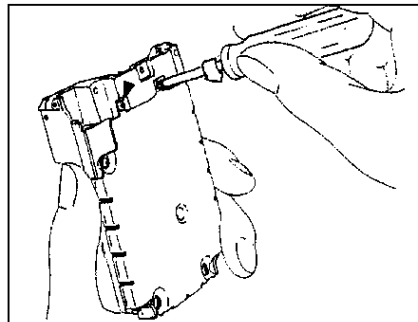

2. Remove the three screws (PANHEAD, M2X4 with SW) at the indented parts of the RF SHIELD PLATE, and remove the RF SHIELD PLATE.

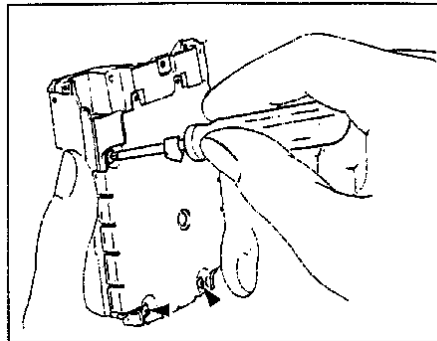

3. Remove the two screws (BIND, M2.6X6) on the side of the CASTING with the screwdriver and remove the PA MODULE RETAINER.

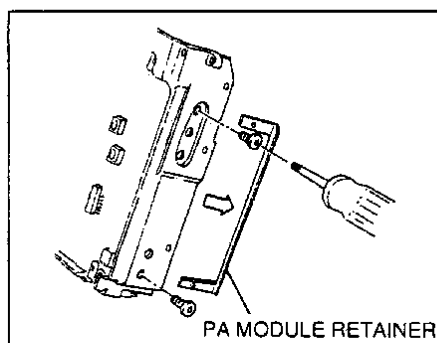

4. Lift up the RF BOARD ASSY. taking care not to damage the connector which connects it with the CONTROL BOARD ASSY. Then remove the RF BOARD ASSY. from the CASTING keeping horizontal state.

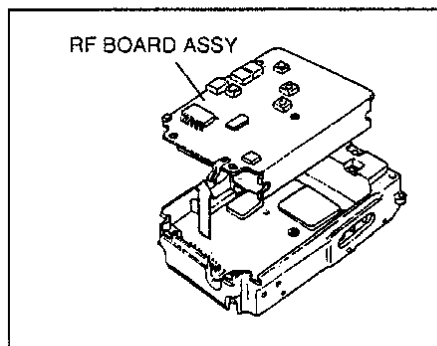

Note: The connector is located on the bottom of the CASTING as shown.

5. Turn the CASTING over and loosen the three screws (PANHEAD with SW, M2X4) on the CONTROL BOARD ASSY. with the screwdriver, and remove the CONTROL BOARD ASSY. from the CASTING.

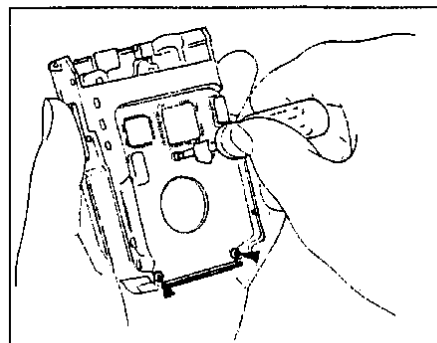

2. M-RK II ASSEMBLY

1. INTERNAL UNIT ASSEMBLY

1. Put the mounting holes on the RF BOARD ASSY. and the bosses at the mounting holes on the CASTING together, and fit the RF BOARD ASSY. with the CASTING.

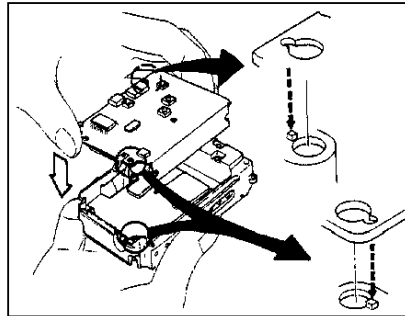

2. Install the RF SHIELD PLATE on the CASTING by fastening the three screws (PANHEAD with SW, M2X4) at the concave parts through the RF BOARD ASSY. with the screwdriver. Torque to 1.5 kg-cm \pm 10%.

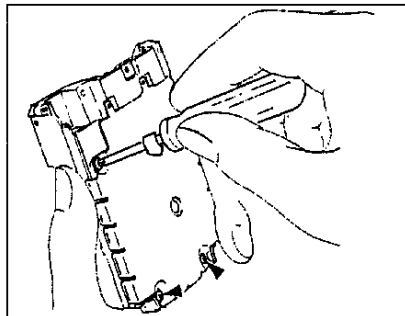

3. Secure the RF SHIELD PLATE by fastening the two screws (PANHEAD, M2X2) on the upper part with the screwdriver. Torque to 1.5 kg-cm \pm 10%.

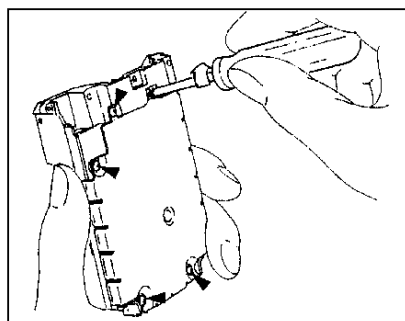

4. Insert the PA MODULE RETAINER into mounting holes and secure it by fastening the two screws (BIND, M2.6X6) on the side of the CASTING with the screwdriver. Torque to 3.6 kg-cm \pm 10%.

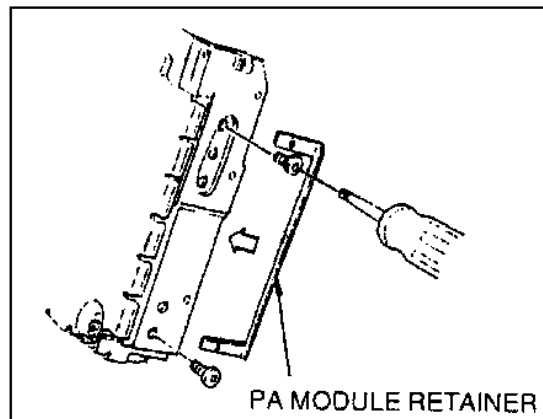

5. Turn the CASTING over and fit the connectors of the RF BOARD ASSY. and the CONTROL BOARD ASSY.

Note: Be careful not to damage the connector pins.

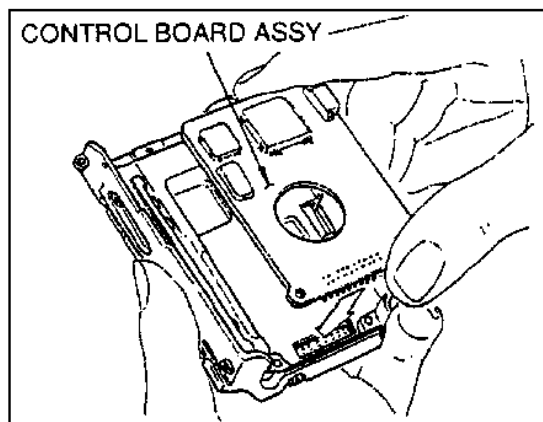

6. Secure the CONTROL BOARD ASSY. in the CASTING by fastening the three screws (PAN-HEAD with the SW, M2X4) with the screwdriver. Torque to 1.5 kg-cm \pm 10%.

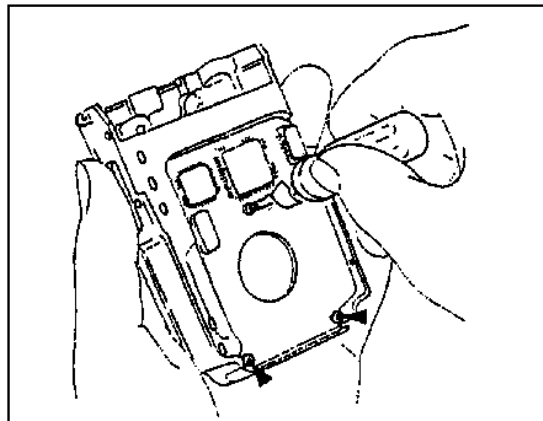

2. LCD/KB FLEX ASSY. INSTALLATION

1. Engage the upper part of the LCD/KB FLEX ASSY. with the CASTING. First fit the CHANNEL SWITCH side, then fit the EMERGENCY BUTTON SIDE.

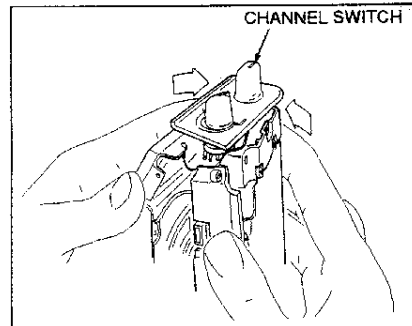

2. After engaging the upper part, fit the bosses of the LOGIC SHIELD PLATE with the holes on both sides of the CASTING.

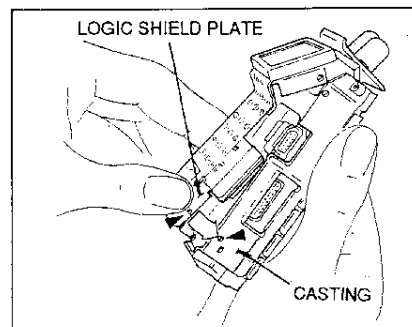

3. Fasten the screw (BTP, M2X3.5) on the upper part of the LCD/KB FLEX ASSY. with the screwdriver. Torque to 1.5 kg-cm \pm 10%.

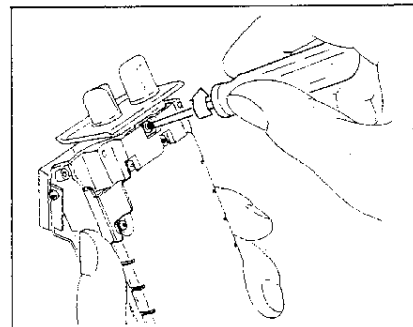

4. Secure the LCD/KB FLEX ASSY. by fastening the two screws (PANHEAD, M2X2) on both sides with the screwdriver. Torque to 1.5 kg-cm \pm 10%.

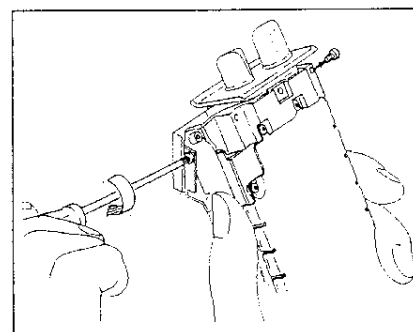

5. Fit the CONNECTOR B securely by pressing the FLEX P.C.B. on the CONNECTOR B with the thumb tip as shown.

Note: Be careful not to damage the connector pins.

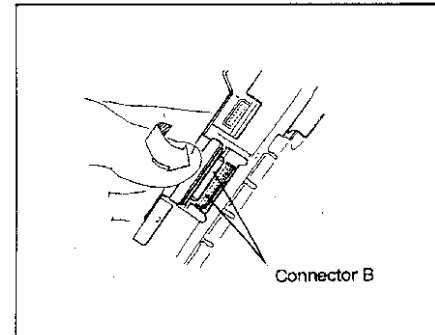

6. Hold the FLEX P.C.B. of the CONNECTOR A with your fingers, and connect by pressing the FLEX P.C.B. with the index finger tip as shown.

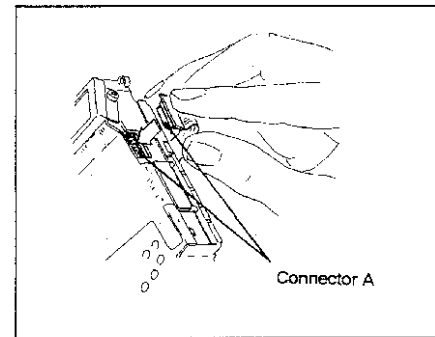

3. INTERNAL UNIT INSTALLATION

1. Place the upper part of the INTERNAL UNIT in the FRONT CASE. After deciding the position, install the INTERNAL UNIT in the FRONT CASE as shown. Then, set two screws (TORX, M3) at the bottom of the FRONT CASE.

Note: Be careful not to catch the FLEX P.C.B. of the CONNECTOR A between the FRONT CASE and the INTERNAL UNIT.

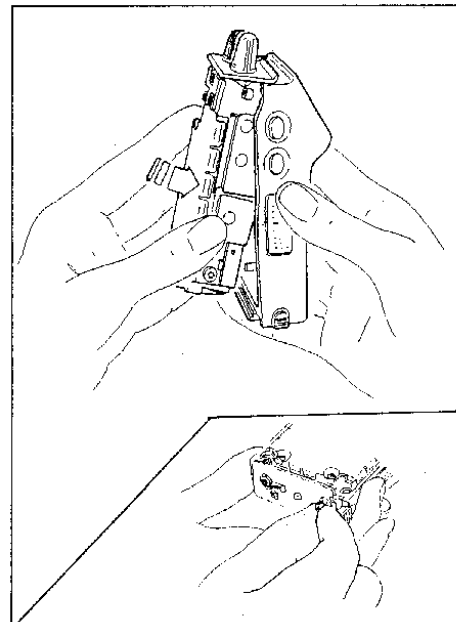

2. Secure the INTERNAL UNIT by fastening the two screws (PANHEAD, M2X6) at the upper part on both sides with the screwdriver. Torque to 1.5 kg-cm \pm 10%.

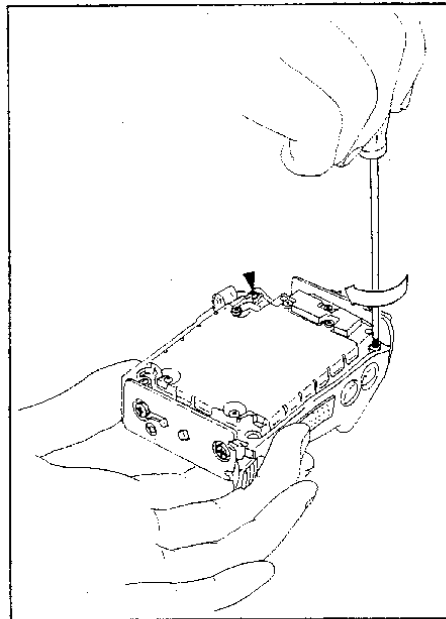

3. Fasten the two flat screws (M3) on the bottom of the FRONT CASE with the screwdriver. Torque to 5.5 kg-cm \pm 10%.

Note: After tightening screw, return the negative (-) battery contact (on the left side of diagram) just a little bit counterclockwise so the the contact is centered in the mounting groove.

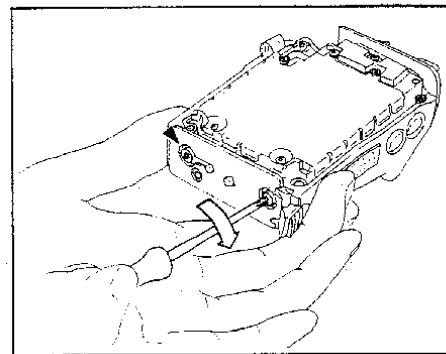

4. REAR CASE INSTALLATION

1. Install the REAR CASE and fasten the four captive screws (TORX BIND, M2.6X6) with the TORX screwdriver (T-8). Take care not to catch the FLEX P.C.B. of the CONNECTOR A between the REAR CASE and the FRONT CASE.

Note: Fastening torque should not be over 3.5Kg-cm.

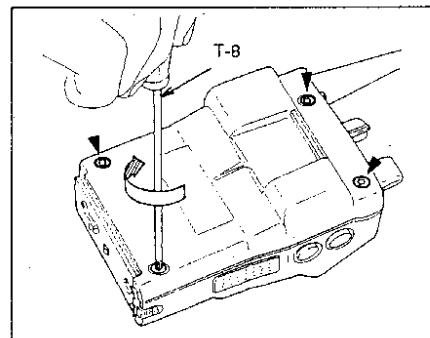

M-RK SCAN

PERSONAL RADIO

DISASSEMBLY AND ASSEMBLY PROCEDURE

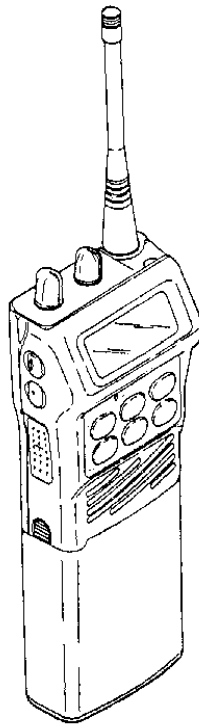

● CAUTION - BEFORE PROCEEDING -

1. Please read this booklet carefully before carrying out procedures.
2. After reading, keep it somewhere convenient for reference.
3. Always remove BATTERY PACK before procedure, as it may cause a power short.
(See page 26 "1. BATTERY PACK REMOVAL".)
4. Do not follow any procedures other than what is shown in this booklet as it may cause the main unit to malfunction.

● Necessary Tools

- The following tools are necessary for assembly and disassembly.
 - TORX screwdriver (T-8)
 - Screwdriver (M2)
 - Torque wrench with adapters

1. M-RK SCAN DISASSEMBLY

1. BATTERY PACK REMOVAL

1. Make sure that the VOLUME SWITCH is turned off.

2. Release the BATTERY LATCH by pushing it up in the direction of Arrow 1.

3. Remove the BATTERY PACK by sliding it in the direction of Arrow 2.

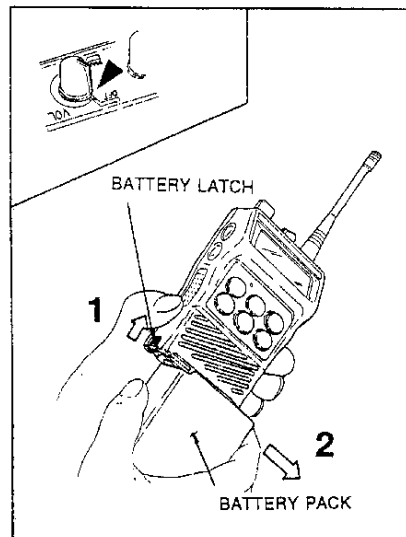

2. REAR CASE REMOVAL

1. Loosen the four captive screws (TORX BIND, M2.6X6) on the REAR CASE with the TORX screwdriver (T-8) and remove the REAR CASE.

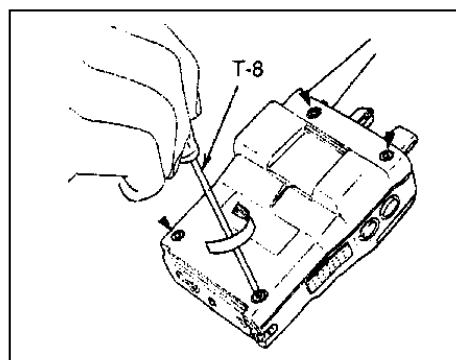

3. INTERNAL UNIT REMOVAL

1. Remove the REAR CASE, and loosen the two flat screws (M3) on the bottom of the main unit with the screwdriver.

2. Gently pull the loosened screws fully.

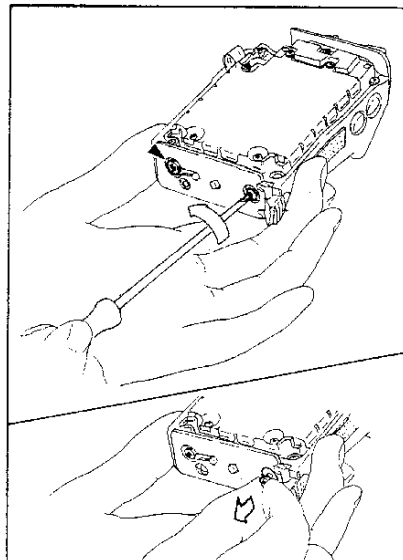

3. Loosen the two screws (PANHEAD, M2X6) on both sides at the upper part with the screwdriver and remove them.

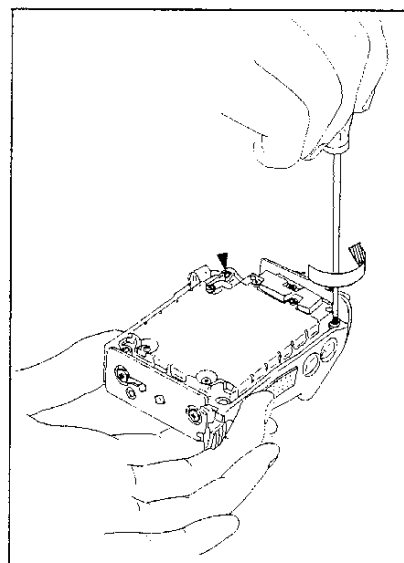

Note: For REAR CASE removal, see page 26 "2. REAR CASE REMOVAL."

4. Separate the INTERNAL UNIT from the FRONT CASE. First, disengage the bottom part of INTERNAL UNIT as shown, taking care not to damage the fitting between the TOP PANEL and the FRONT CASE.

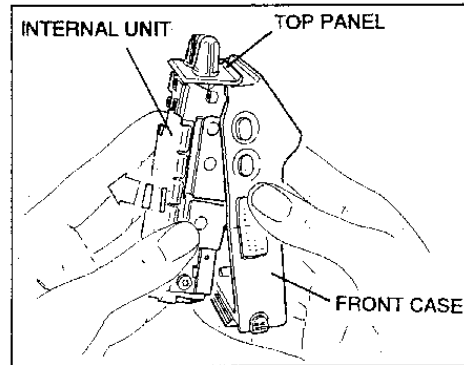

5. Remove the INTERNAL UNIT from the FRONT CASE being careful not to damage the FLEX P.C.B.

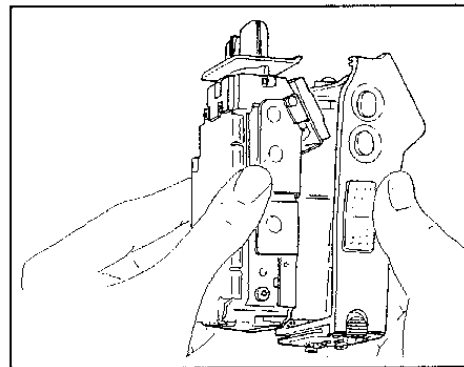

6. Disconnect the CONNECTOR A with a flat tipped tool.

Note: Pull the CONNECTOR A straight out being careful not to damage the connector pins.

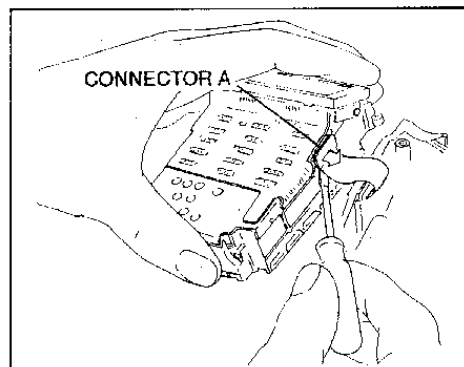

4. LCD/KB FLEX ASSY. REMOVAL

1. Loosen the screw (BTP, M2X3.5) on the back of the LCD/KB FLEX ASSY. with the screwdriver and remove it.

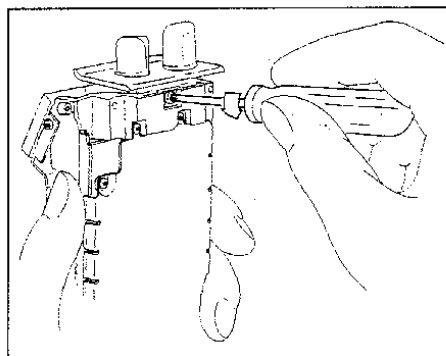

2. Loosen the two screws (PANHEAD, M2X2) on both sides of the LED FLEX ASSY. with the screwdriver and remove them.

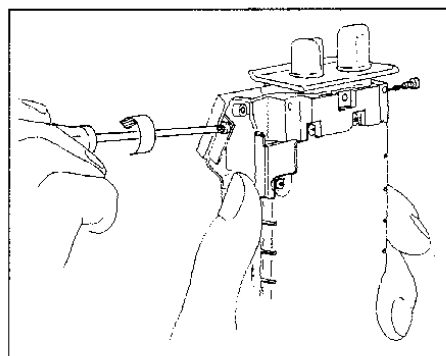

3. Insert a flat tipped tool into the frame of the CONNECTOR B as shown, and lift up the CONNECTOR B slightly to disengage the fitting.

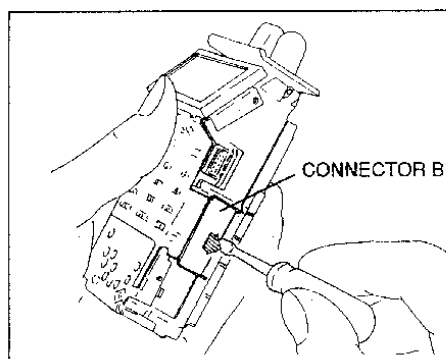

4. Hold the CONNECTOR B with your fingers and remove it taking care not to damage the connector pins.

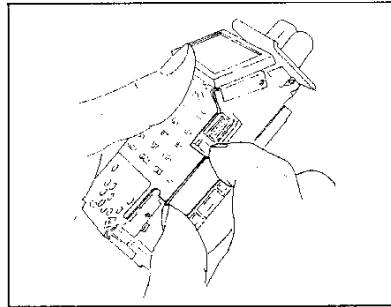

5. Insert a tool with thin end such as a minus screwdriver at the fitting between the LCD/KB FLEX ASSY. and the protruding part of the CHASSIS. Then disengage the fitting by twisting the tool, and remove the LCD/KB FLEX ASSY. gently.

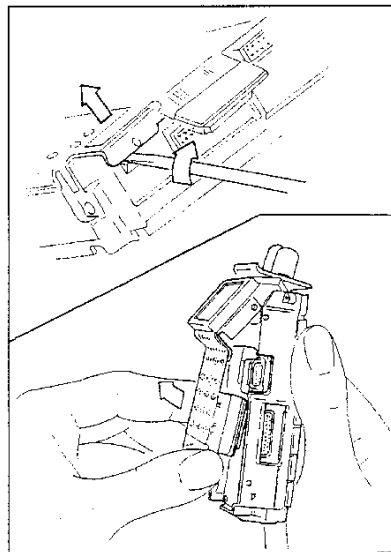

5. RF BOARD ASSY. AND CONTROL BOARD ASSY. REMOVAL

1. Loosen the two screws (PANHEAD, M2X2) at the upper part of the RF SHIELD PLATE with the screwdriver and remove them.

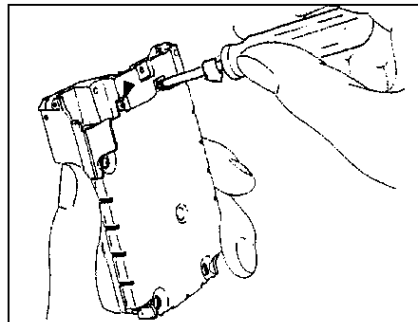

2. Remove the three screws (PANHEAD, M2X4 with SW) at the indented parts of the RF SHIELD PLATE, and remove the RF SHIELD PLATE.

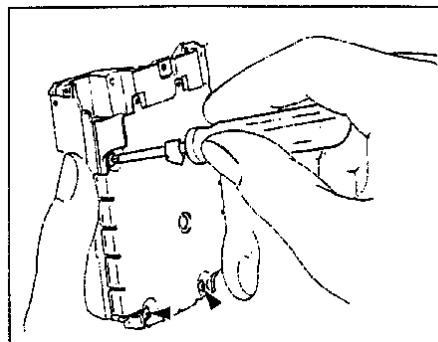

3. Remove the two screws (BIND, M2.6X6) on the side of the CASTING with the screwdriver and remove the PA MODULE RETAINER.

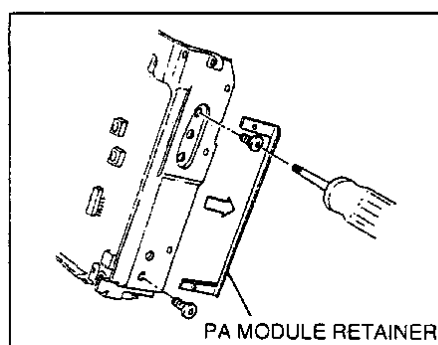

4. Lift up the RF BOARD ASSY. taking care not to damage the connector which connects it with the CONTROL BOARD ASSY. Then remove the RF BOARD ASSY. from the CASTING keeping horizontal state.

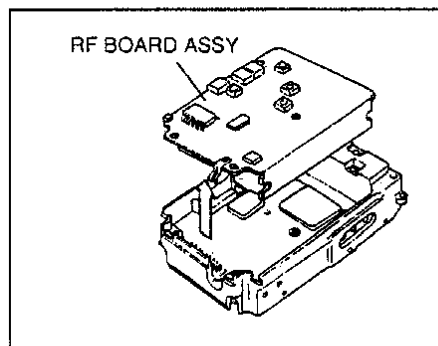

Note: The connector is located on the bottom of the CASTING as shown.

5. Turn the CASTING over and loosen the three screws (PANHEAD with SW, M2X4) on the CONTROL BOARD ASSY. with the screwdriver, and remove the CONTROL BOARD ASSY. from the CASTING.

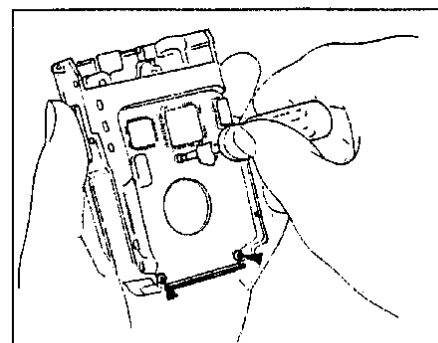

2. M-RK SCAN ASSEMBLY

1. INTERNAL UNIT ASSEMBLY

1. Put the mounting holes on the RF BOARD ASSY. and the bosses at the mounting holes on the CASTING together, and fit the RF BOARD ASSY. with the CASTING.

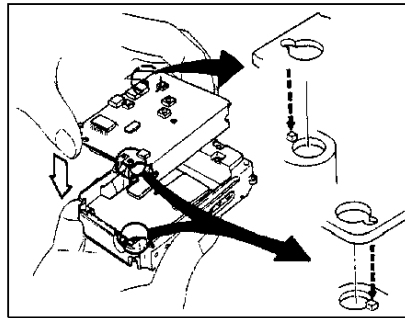

2. Install the RF SHIELD PLATE on the CASTING by fastening the three screws (PANHEAD with SW, M2X4) at the concave parts through the RF BOARD ASSY. with the screwdriver. Torque to 1.5 kg-cm \pm 10%.

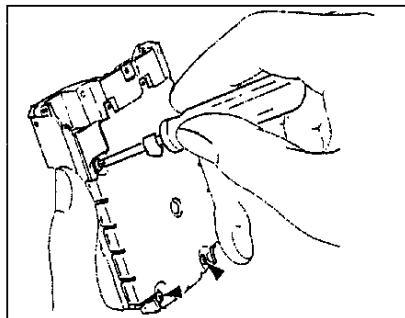

3. Secure the RF SHIELD PLATE by fastening the two screws (PANHEAD, M2X2) on the upper part with the screwdriver. Torque to 1.5 kg-cm \pm 10%.

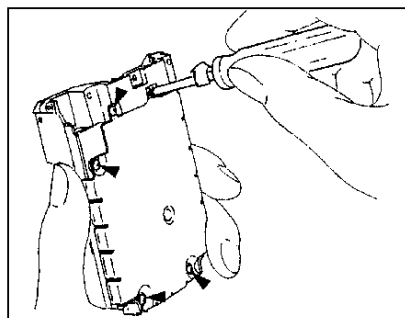

4. Insert the PA MODULE RETAINER into mounting holes and secure it by fastening the two screws (BIND, M2.6X6) on the side of the CASTING with the screwdriver. Torque to 3.6 kg-cm \pm 10%.

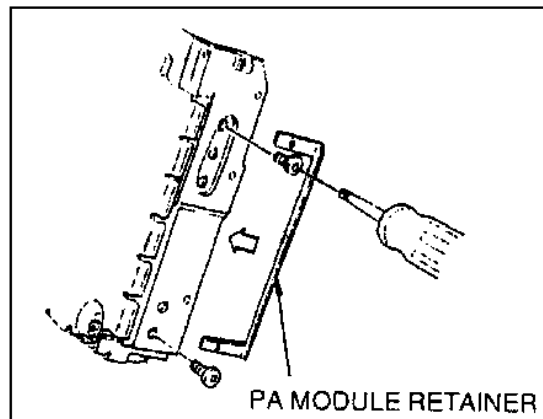

5. Turn the CASTING over and fit the connectors of the RF BOARD ASSY. and the CONTROL BOARD ASSY.

Note: Be careful not to damage the connector pins.

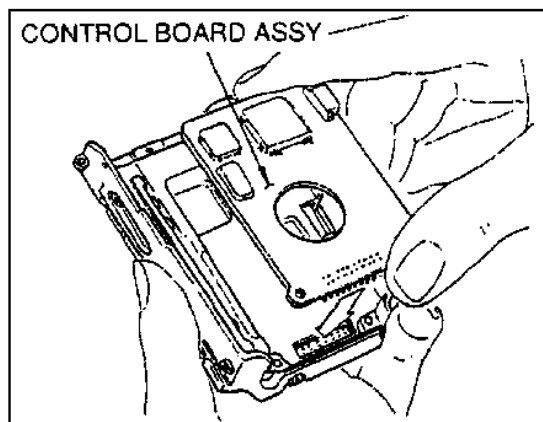

6. Secure the CONTROL BOARD ASSY. in the CASTING by fastening the three screws (PAN-HEAD with the SW, M2X4) with the screwdriver. Torque to 1.5 kg-cm \pm 10%.

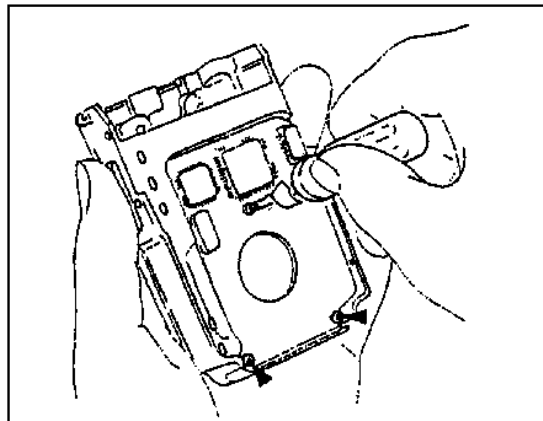

2. LED FLEX ASSY. INSTALLATION

1. Engage the upper part of the LCD/KB FLEX ASSY. with the CASTING. First fit the CHANNEL SWITCH side, then fit the EMERGENCY BUTTON SIDE.

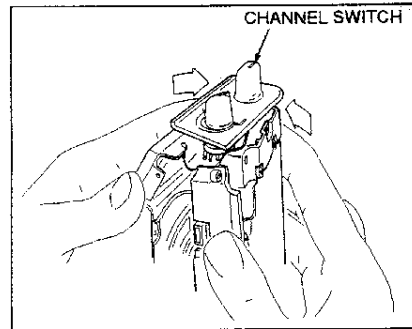

2. After engaging the upper part, fit the bosses of the LOGIC SHIELD PLATE with the holes on both sides of the CASTING.

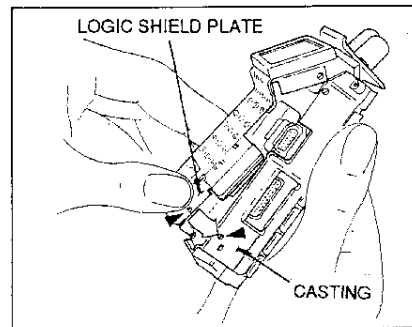

3. Fasten the screw (BTP, M2X3.5) on the upper part of the LCD/KB FLEX ASSY. with the screwdriver. Torque to 1.5 kg-cm \pm 10%.

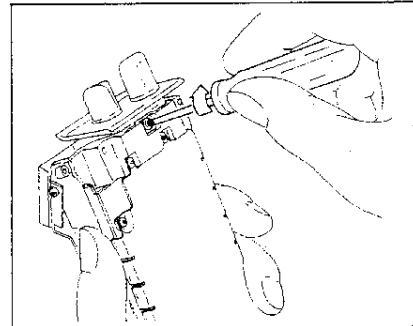

4. Secure the LCD/KB FLEX ASSY. by fastening the two screws (PANHEAD, M2X2) on both sides with the screwdriver. Torque to 1.5 kg-cm \pm 10%.

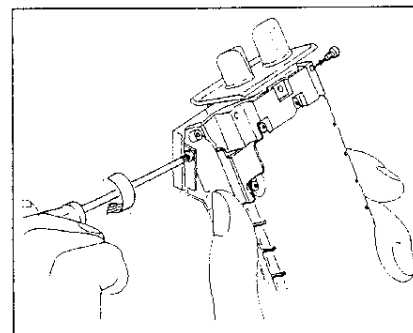

5. Fit the CONNECTOR B securely by pressing the FLEX P.C.B. on the CONNECTOR B with the thumb tip as shown.

Note: Be careful not to damage the connector pins.

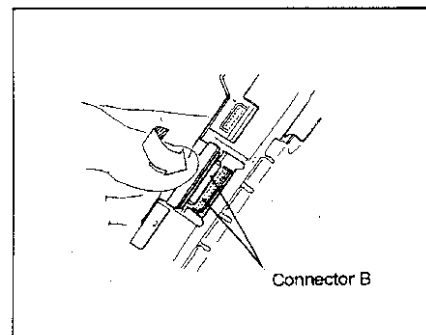

6. Hold the FLEX P.C.B. of the CONNECTOR A with your fingers, and connect by pressing the FLEX P.C.B. with the index finger tip as shown.

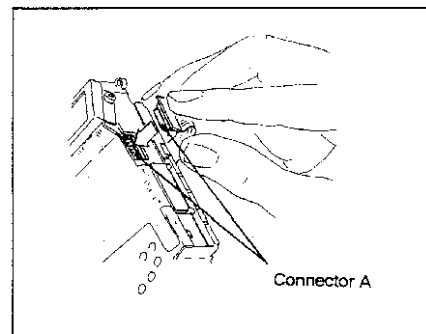

3. INTERNAL UNIT INSTALLATION

1. Place the upper part of the INTERNAL UNIT in the FRONT CASE. After deciding the position, install the INTERNAL UNIT in the FRONT CASE as shown. Then, set two screws (TORX, M3) at the bottom of the FRONT CASE.

Note: Be careful not to catch the FLEX P.C.B. of the CONNECTOR A between the FRONT CASE and the INTERNAL UNIT.

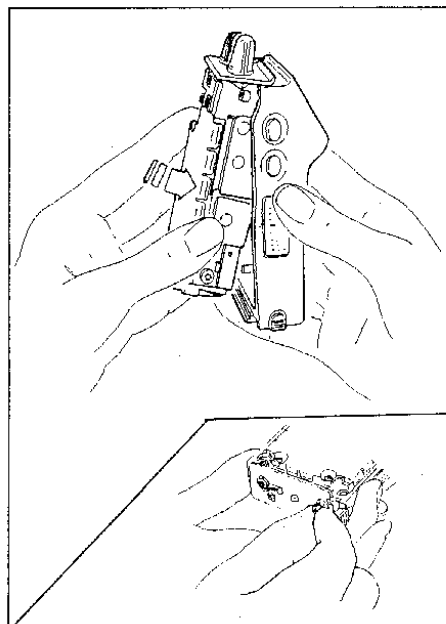

2. Secure the INTERNAL UNIT by fastening the two screws (PANHEAD, M2X6) at the upper part on both sides with the screwdriver. Torque to 1.5 kg-cm \pm 10%.

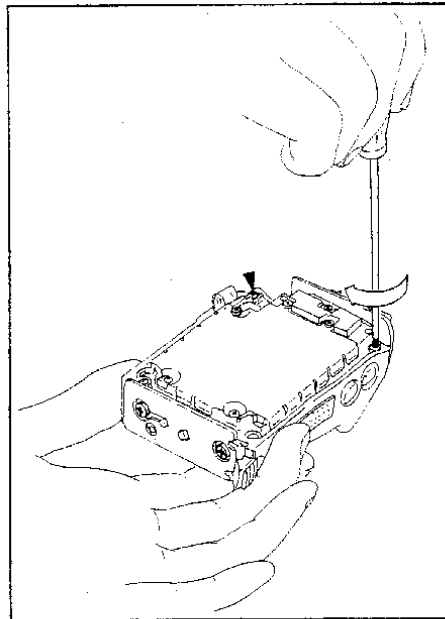

3. Fasten the two flat screws (M3) on the bottom of the FRONT CASE with the screwdriver. Torque to 5.5 kg-cm \pm 10%.

Note: After tightening screw, return the negative (-) battery contact (on the left side of diagram) just a little bit counterclockwise so the the contact is centered in the mounting groove.

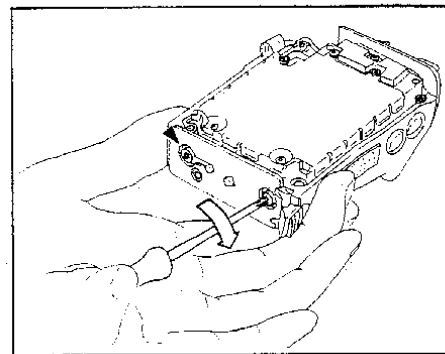

4. REAR CASE INSTALLATION

1. Install the REAR CASE and fasten the four captive screws (TORX BIND, M2.6X6) with the TORX screwdriver (T-8). Take care not to catch the FLEX P.C.B. of the CONNECTOR A between the REAR CASE and the FRONT CASE.

Note: Fastening torque should not be over 3.5Kg-cm.

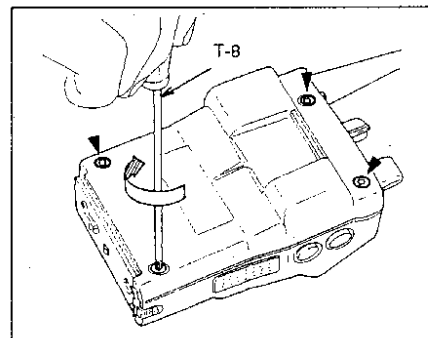

MIC SHEET Replacement Procedure (For the M-RK II)

1. Unscrew the attachment screw (M1.7x2.5, 8 places) on Plate-retaining to remove it.

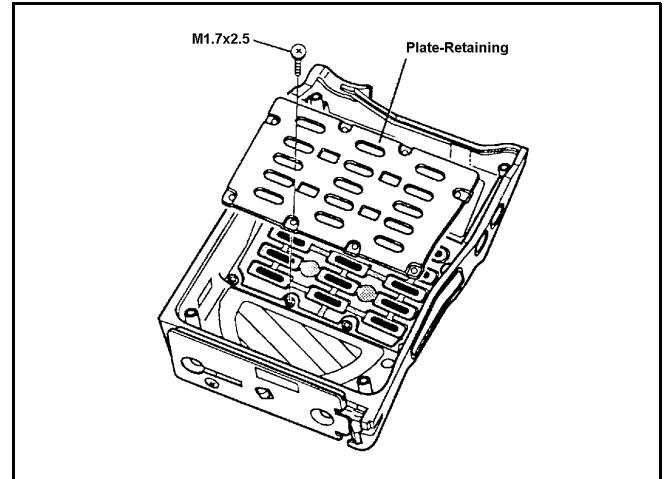

2. Remove Key Pad from Front Case.

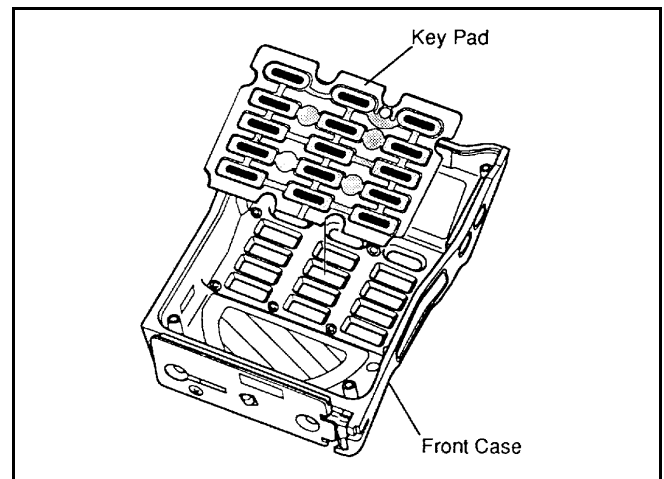

3. Remove Mic Sheet with the sharp ended Pin Set, and thoroughly remove the adhesive on the Front Case.

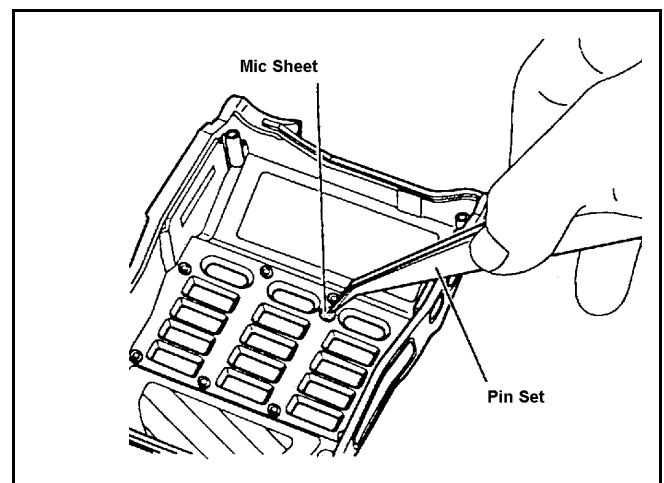

4. Peel off the back sheet on the Mic Sheet and stick on the attachment position.

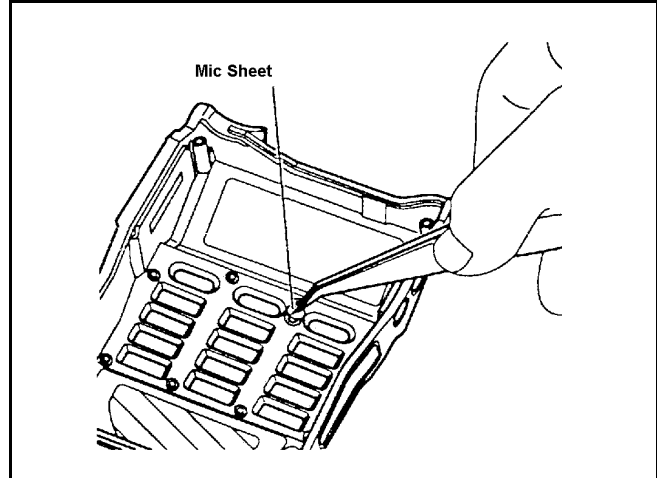

5. Attach the Key Pad and Plate-Retaining on their original positions and screw the attachment screws (M1.7x2.5, 8 places) with precision driver (+).

Note: Fastening torque should not be over 1.0kg-cm.

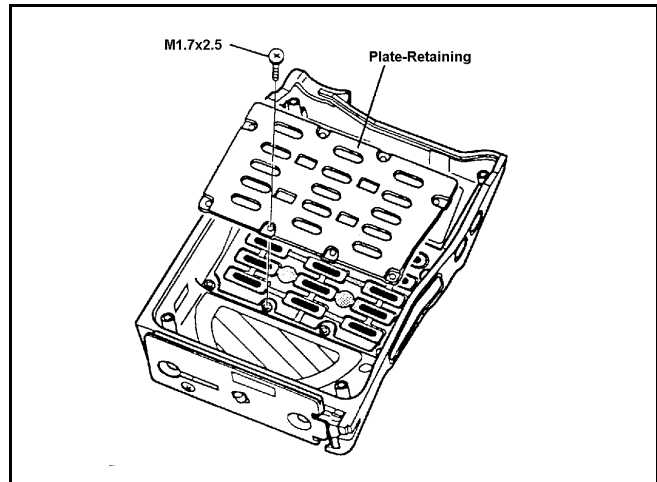

MIC SHEET Replacement Procedure (For the M-RK SCAN)

1. Unscrew the attachment screw (M1.7x2.5, 8 places) on Plate-retaining to remove it.

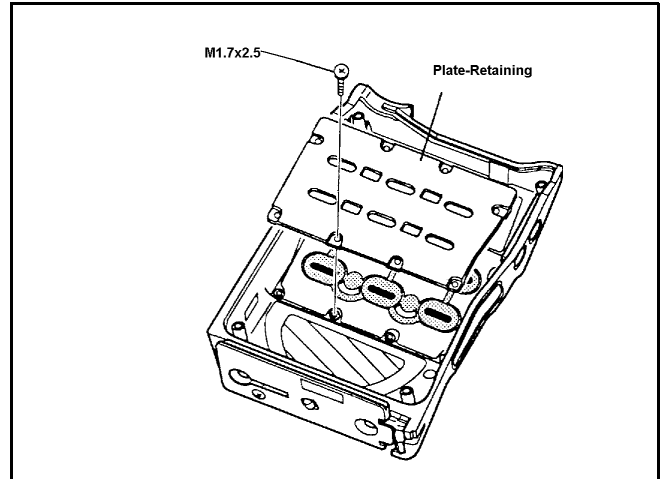

2. Remove Key Pad from Front Case.

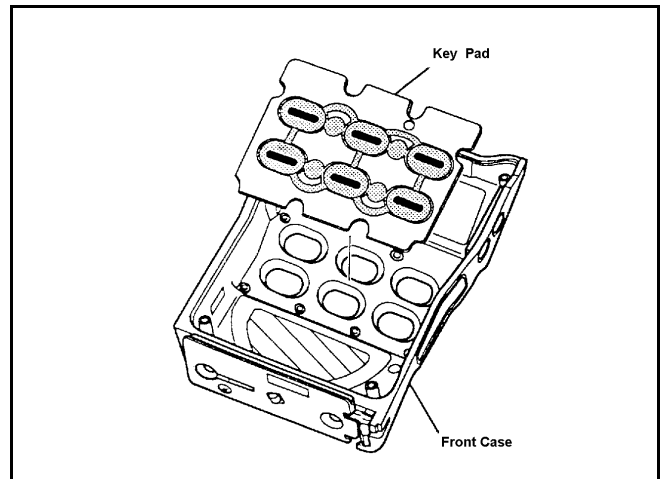

3. Remove Mic Sheet with the sharp ended Pin Set, and thoroughly remove the adhesive on the Front Case.

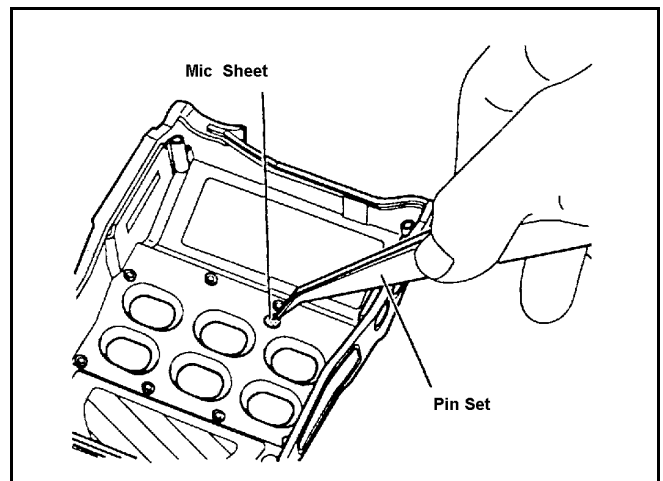

4. Peel off the back sheet on the Mic Sheet and stick on the attachment position.

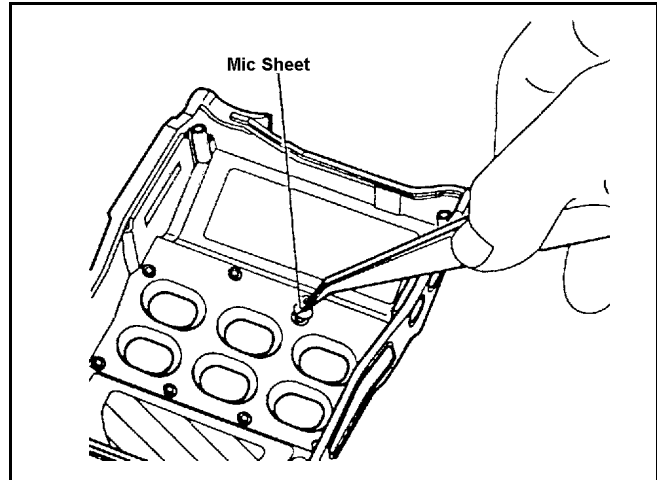

5. Attach the Key Pad and Plate-Retaining on their original positions and screw the attachment screws (M1.7x2.5, 8 places) with precision driver (+).

Note: Fastening torque should not be over 1.0kg-cm.

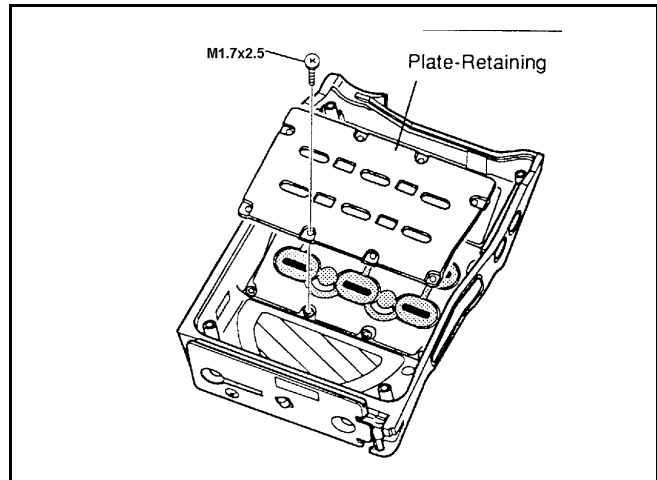

Replacement Procedure of TOP - PANEL (In case of LED FLEX ASSY)

DISASSEMBLY PROCEDURE

1. Pull out VOL knob and CH knob carefully (in direction of arrows) so that switch is not damaged.

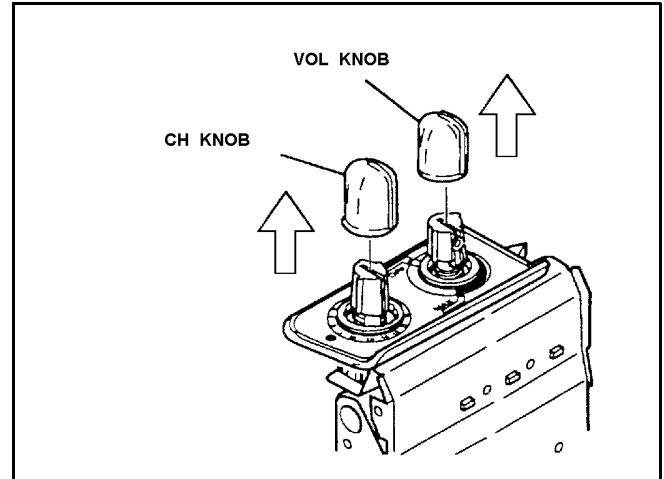

2. Loosen the hex socket set screws on VOL knob stopper and CH knob stopper with hex driver and remove these stoppers.

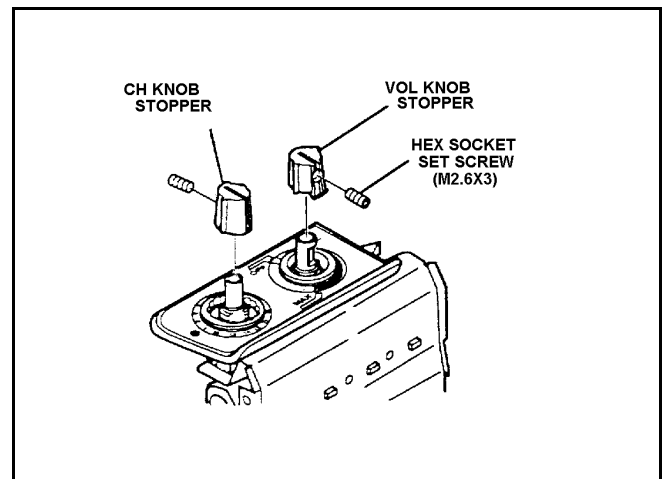

3. Loosen the special nuts on VOL switch and CH switch. Then remove them with the special driver.

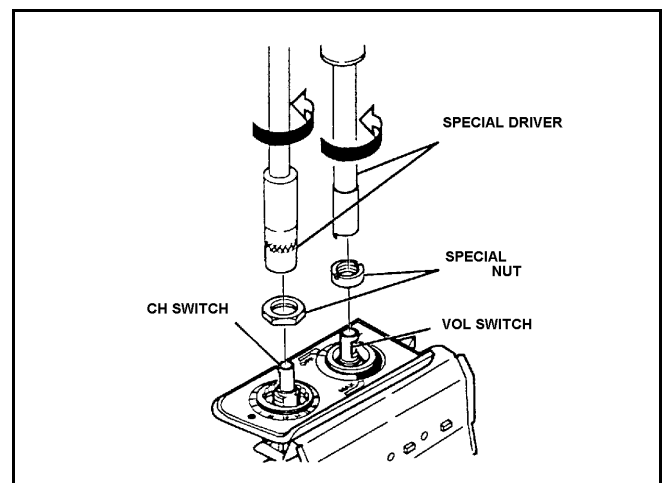

LBI-38741D

4. Loosen the set screws (M2x3.5, 2 places) on the back of the top panel with a precision driver (+) and remove.

* The set screws is in a hidden spot, so be careful not to damage the FLEX P.C.B.

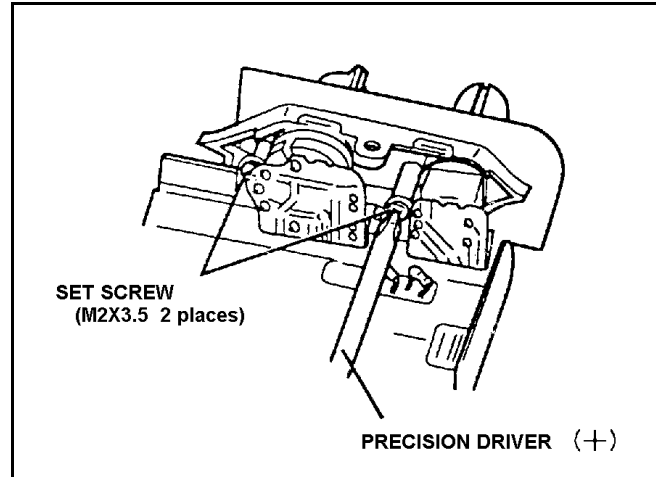

5. Remove the Top-Panel carefully and replace with new one.

* Be careful not to lose O-ring.

* Please take care in removing the Top-Panel so that FLEX P.C.B is not damaged.

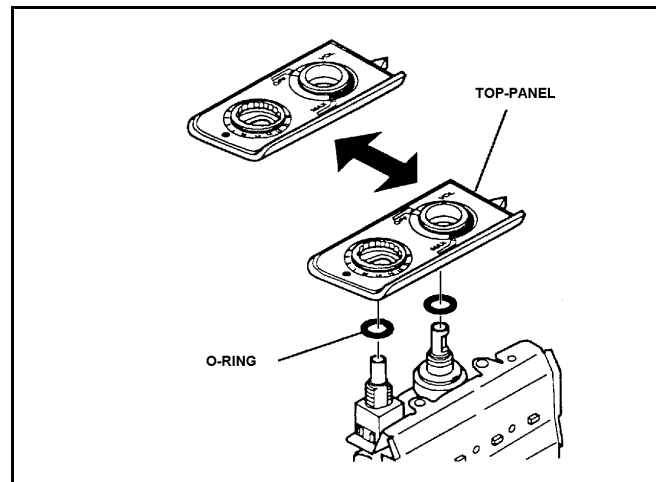

Replacement Procedure of TOP - PANEL (In case of LED FLEX ASSY) - Cont.

ASSEMBLY PROCEDURE

- Put the Top-Panel on the main unit. (Adjust the hook on VOL switch to fit the groove on the back side of the Top-Panel, and also adjust the D-cut shape on the Top-Panel to fit the CH switch).

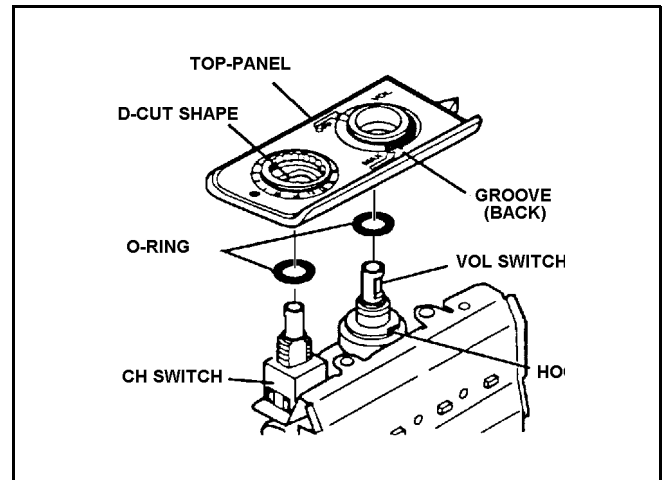

- Put the SPECIAL NUT on VOL switch and put SPECIAL HEXAGON NUT on CH switch. Then fasten them with each special driver at proper fastening torque. (SPECIAL HEXAGON NUT torque : 6kg-cm. SPECIAL NUT torque : 5kg-cm.).

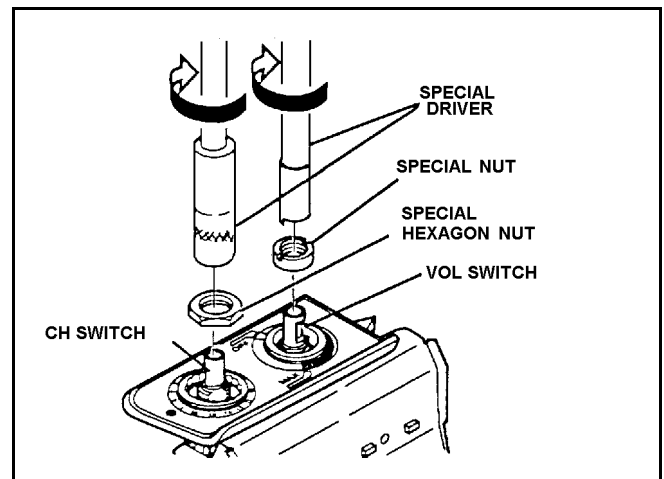

* Be careful not to fasten both switches while tilting them.

- Adjust the attachment holes on FLEX P.C.B. to fit the attachment screw holes on Top-Panel by fastening the set screws (M2x3.5, 2 places) with a precision driver (+).

* Be careful not to damage FLEX P.C.B. when adjusting the attachment hole.

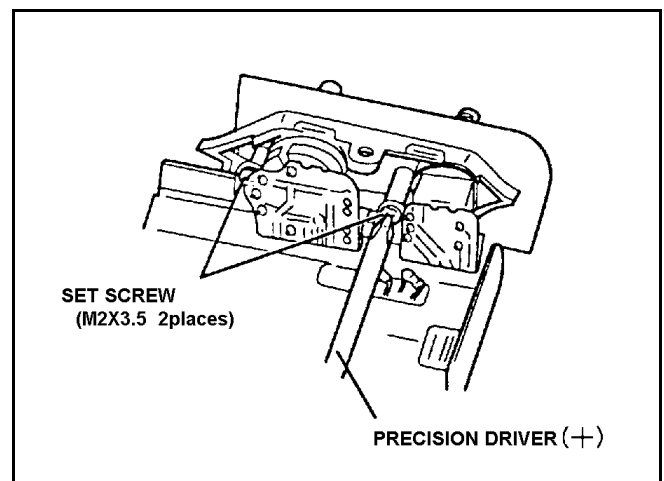

Note: Fastening torque should not be over 1.5kg-cm.

- Put VOL knob stopper on VOL switch and put CH knob stopper on CH switch. Then fasten the hex socket set screws (M2.6x3) with hexagon driver at proper fastening torque (3.5kg-cm).

Note: Please fasten the M2.6 screw by adjusting to fit the concave position of the shaft. (Please see fig.)

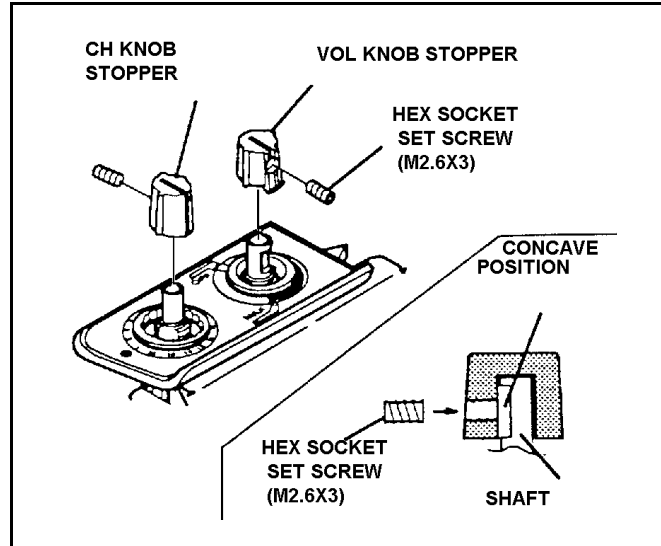

- Put VOL knob on VOL knob stopper and put CH knob on CH knob stopper by adjusting each key groove to fit the convex part.

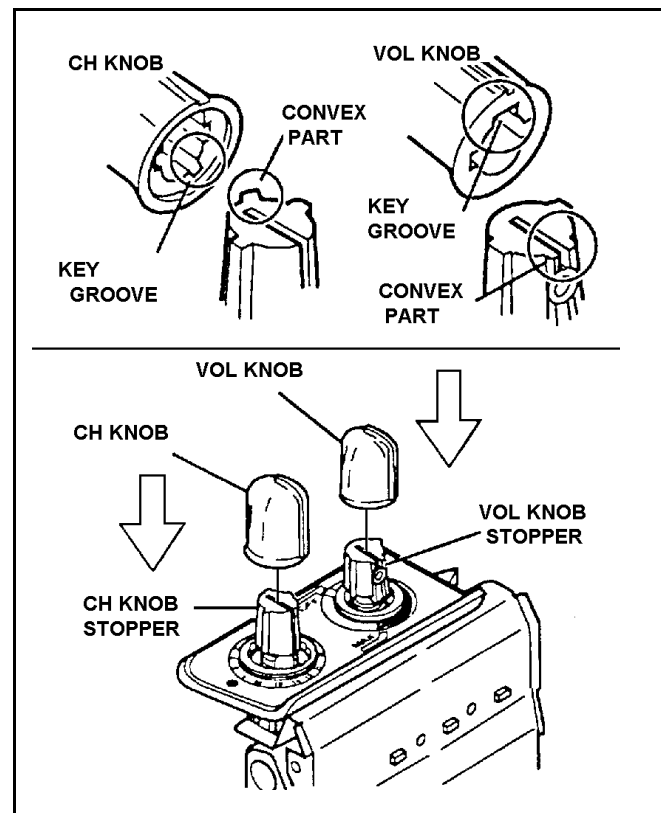

Replacement Procedure of TOP - PANEL (In case of LCD/KB FLEX ASSY)

DISASSEMBLY PROCEDURE

1. Pull out VOL knob and CH knob carefully (in direction of arrows) so that switch is not damaged.

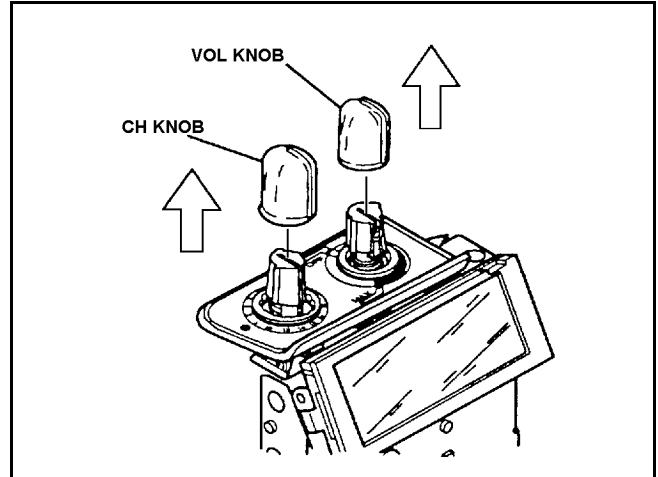

2. Loosen the hex socket set screws on VOL knob stopper and CH knob stopper with hex driver and remove these stoppers.

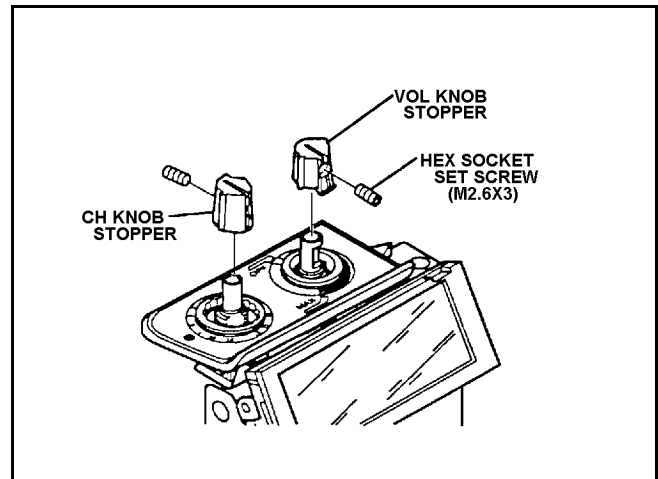

3. Loosen the special nuts on VOL switch and CH switch. Then remove them with the special driver.

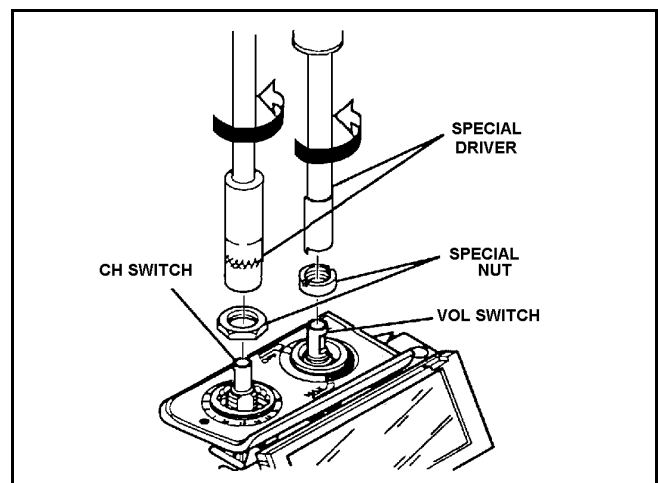

4. Loosen the set screws (M2x3.5, 2 places) on the back of the top panel with a precision driver (+) and remove.

* The set screws is in a hidden spot, so be careful not to damage the FLEX P.C.B.

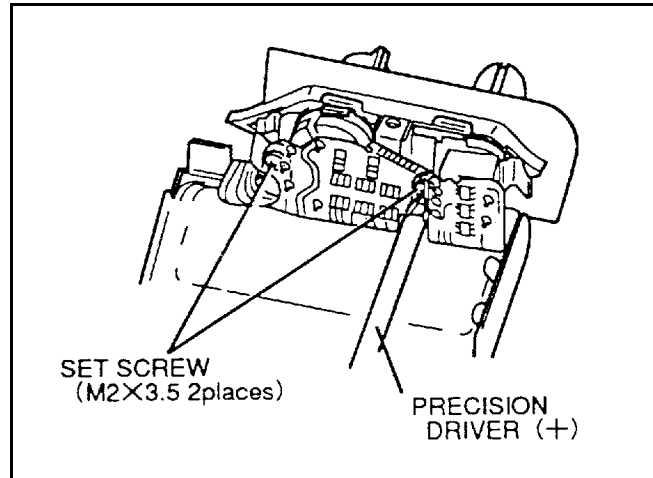

5. Remove the Top-Panel carefully and replace with new one.

* Be careful not to bend or damage the shield plate or lose the O-ring.

* Please take care in removing the Top-Panel so that FLEX P.C.B is not damaged.

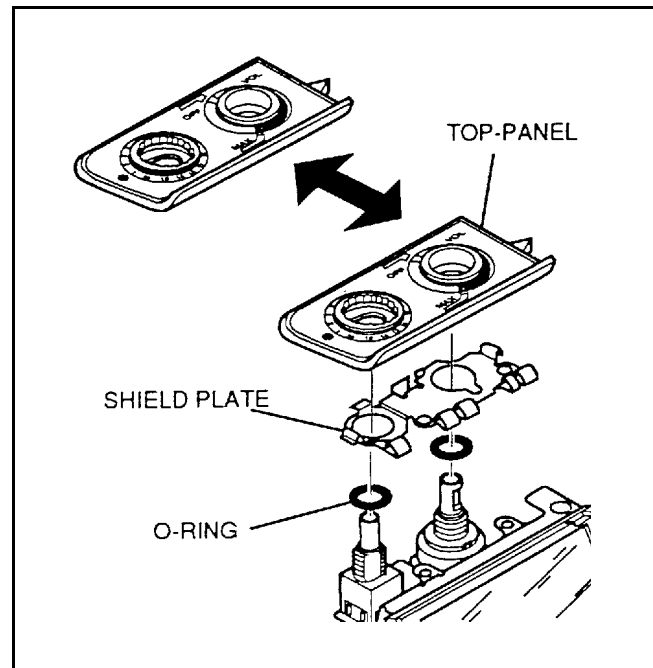

Replacement Procedure of TOP - PANEL (In case of LCD/KB FLEX ASSY)

ASSEMBLY PROCEDURE

1. Put the Top-Panel on the main unit. (Adjust the hook on VOL switch to fit the groove on the back side of the Top-Panel and the shield plate, and also adjust the D-cut shape on the Top-Panel to fit the CH switch).

* Be careful not to bend or damage the shield plate.

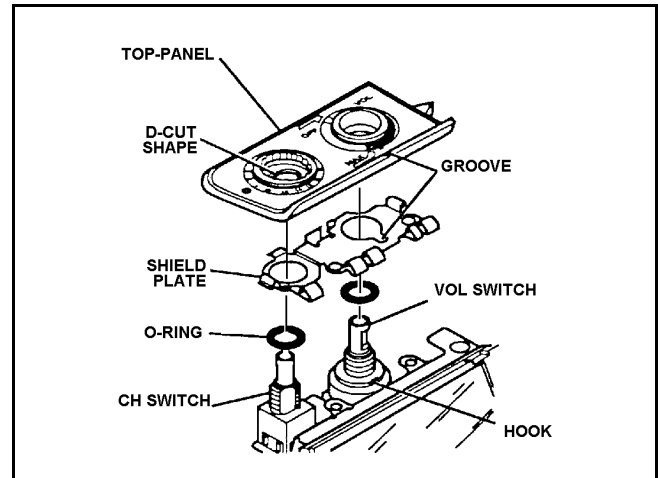

2. Put the SPECIAL NUT on VOL switch and put SPECIAL HEXAGON NUT on CH switch. Then fasten them with each special driver at proper fastening torque. (SPECIAL HEXAGON NUT torque : 6kg-cm. SPECIAL NUT torque : 5kg-cm.).

* Be careful not to fasten both switches while tilting them.

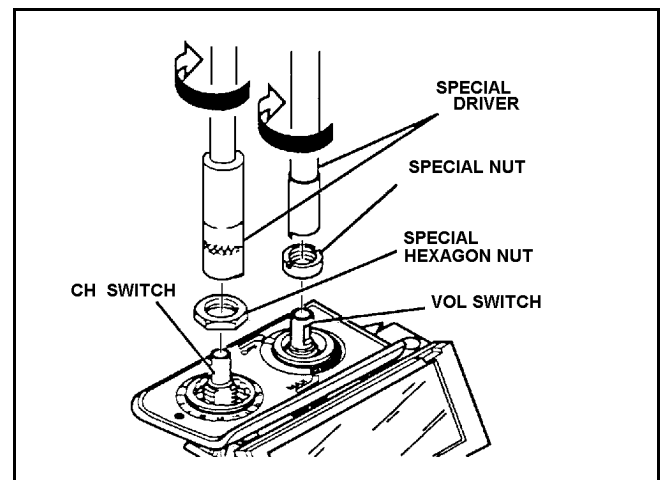

3. Adjust the attachment holes on FLEX P.C.B. to fit the attachment screw holes on Top-Panel by fastening the set screws (M2x3.5, 2 places) with a precision driver (+).

* Be careful not to damage FLEX P.C.B. when adjusting the attachment hole.

Note: Fastening torque should not be over 1.5kg-cm.

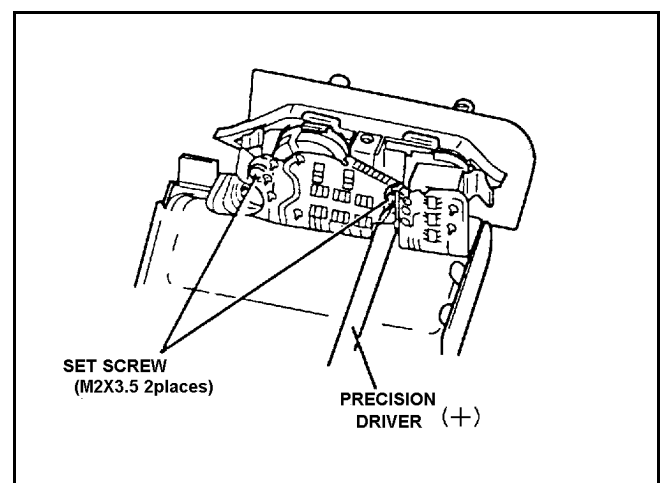

- Put VOL knob stopper on VOL switch and put CH knob stopper on CH switch. Then fasten the hex socket set screws (M2.6x3) with hexagon driver at proper fastening torque (3.5kg-cm).

Note: Please fasten the M2.6 screw by adjusting to fit the concave position of the shaft. (Please see fig.)

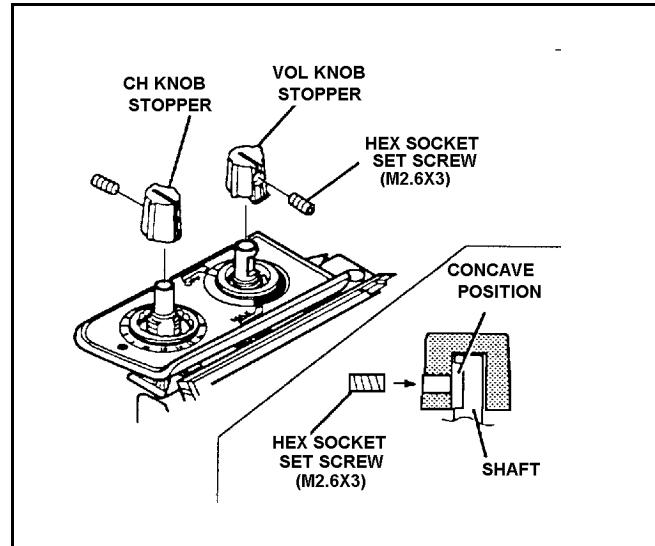

- Put VOL knob on VOL knob stopper and put CH knob on CH knob stopper by adjusting each key groove to fit the convex part.

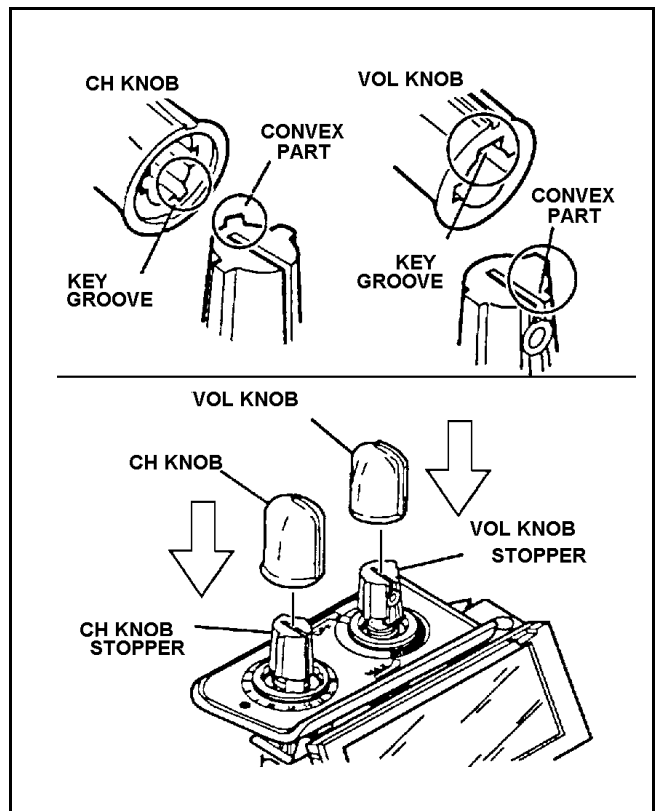

Replacement Procedure of (+) BATTERY CONTACT

***Turn the main unit upside down during replacement
so that the parts are neither dropped nor lost.**

1. Loosen the set screw (FLAT HEAD TORX SCREW M3x12, 2 places) and remove (-) BATTERY CONTACT.

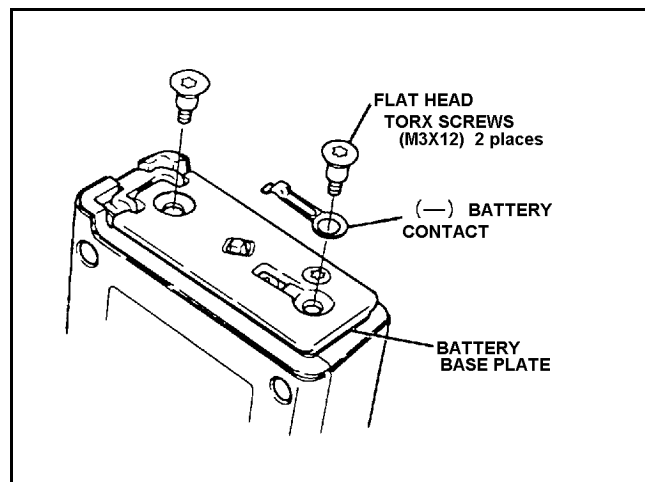

2. Loosen the set screw (TORX SCREW M2x3.5) on BATTERY BASE PLATE and remove the plate.

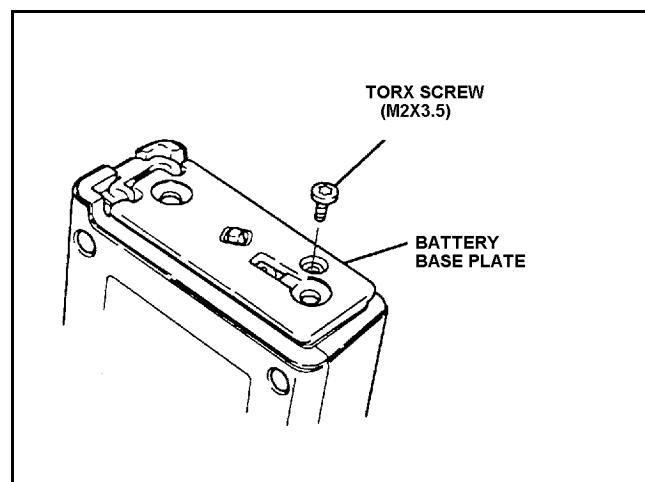

3. Loosen the set screw (PAN HEAD TAPPING SCREW M2x3.5) on A+ CONTACT and remove it for replacement.

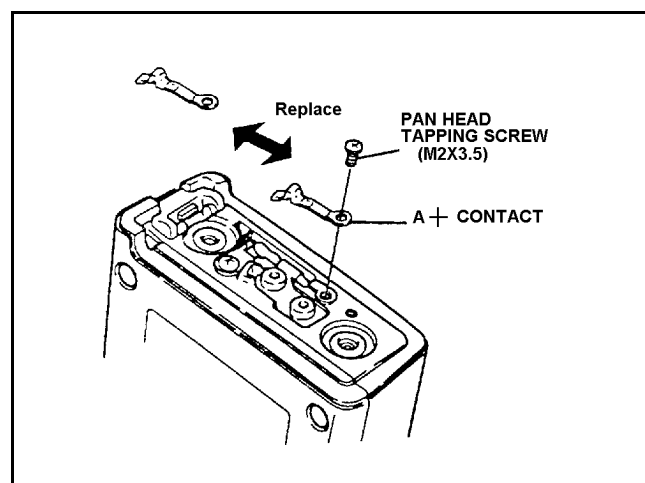

Assembly Procedure of (+) BATTERY CONTACT

***Turn the main unit upside down during replacement so that the parts are neither dropped nor lost.**

1. After the replacement of A+ CONTACT, fasten it with the set screw (PAN HEAD TAPPING SCREW 32x3.5, Fastening torque : 1.5kg-cm).

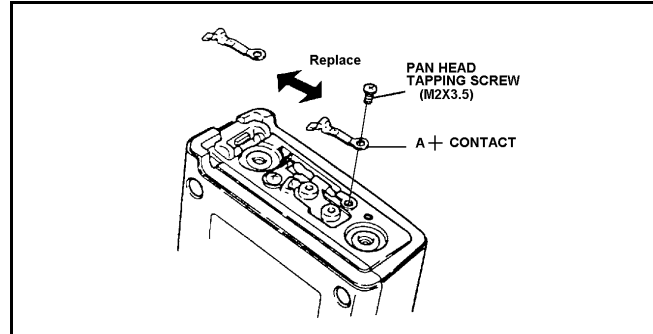

2. Secure BATTERY BASE PLATE with the set screw (TORX SCREW M2x3.5, Fastening torque: 2.0kg-cm) after adjusting the plate on the main unit carefully so that A+ CONTACT is not bent or damaged.

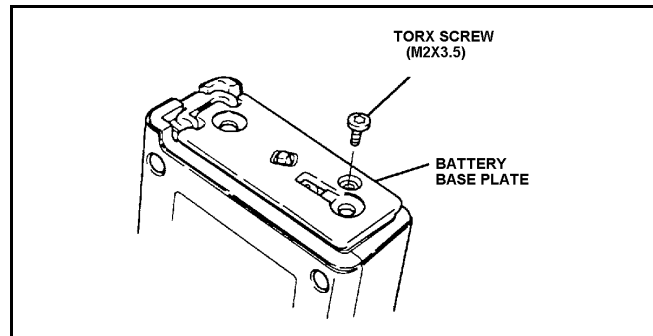

3. Fit (-) BATTERY CONTACT in the BATTERY BASE PLATE and fasten the set screws (FLAT HEAD TORX SCREW M3x12, 2 places, Fastening torque : 5.5 kg-cm).

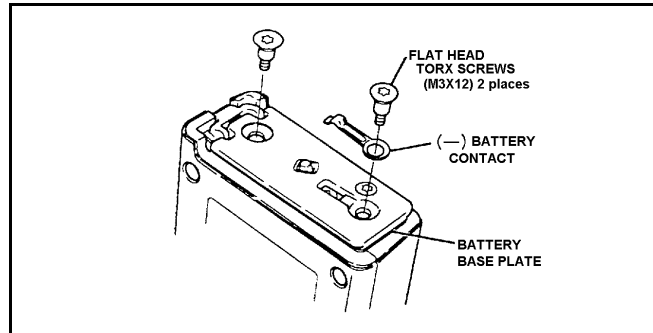

4. Adjust the set screw (FLAT HEAD TORX SCREW M3x12) on the (-) BATTERY CONTACT side by rotating it just a little counter clockwise so that (-) BATTERY CONTACT is set on the center position of the attachment groove.

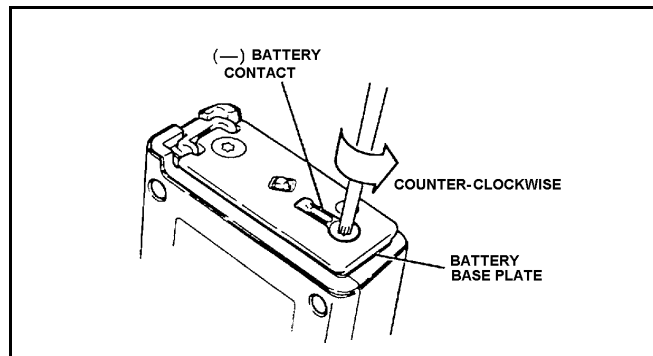

Ericsson Inc.

Private Radio Systems

Mountain View Road

Lynchburg, Virginia

1-800-528-7711 (Outside USA, 804-528-7711)

Printed in U.S.A.