

INSTRUCTION MANUAL

GLB Electronics

300A

CHANNELIZER

INSTRUCTION MANUAL FOR GLB UNIVERSAL CHANNELIZER

INDEX

ALIGNMENT.....	27
BASE STATION POWER SUPPLY.....	6, 9
"BASSY" AUDIO	5
CRYSTAL OPERATION WITH CHANNELIZER...	6
DIRECT FM CONNECTIONS	9
DRIVING CRYSTAL OSCILLATORS	4, 9
FACTORY SERVICE	31
FORMULA FOR OFFSET CRYSTAL	8
FREQUENCIES, OUTPUT	1
FREQUENCY SETTING	3
HIGH-SIDE INJECTION	8
HUM	5
INSTALLATION	3
INSTRUCTIONS (CHANNELIZER ASSY)..10-	26
INTERCONNECTING CABLES	3
INTRODUCTION	1
MATCHING TO TRANSCEIVER	4
OPERATION	2
OUTPUT PROGRAMMING	6
PUSH TO TALK	4
RECEIVER CONSIDERATIONS	4
RETURNS FOR REPAIR	31
RF IN CHANNELIZER	5
SELECTOR SWITCHES	2
SPECIFICATIONS	2
TEST OF INTERFACING	6
THEORY OF OPERATION	7
TRANSMITTER CONSIDERATIONS	5
TROUBLE SHOOTING	28
WARRANTY	31

INSTRUCTION MANUAL FOR GLB MODEL 300A CHANNELIZER

INTRODUCTION

The GLB CHANNELIZER is a true digital frequency synthesizer, using a single crystal to generate 800 output frequencies between 144.000 and 147.995 MHz in steps of 5 KHz. In the transmit mode these frequencies are generated at a subharmonic of the output range. In the receive mode an offset is provided, such that the displayed frequency always is the frequency transmitted or received. The offset is generated by means of a second crystal oscillator in which the crystal frequency determines the receiver IF.

The frequency control switches are arranged in decimal form - that is, separate ten-position switches are used for the 10 and 100 KHz steps. A four position switch is used to select MHz steps. Thus the frequencies in use can be read directly from the switch settings.

For repeater operation, two 600KHz offsets are provided. These are selectable plus and minus 600 KHz. Additional offsets can be provided on special order.

The output frequency ranges of the Channelizer can be changed by means of inserting jumpers on the circuit boards, permitting great latitude in adapting it to various transceivers. In most cases no changes have to be made to the mating transceiver, and often a direct connection can be made to the crystal sockets. The Channelizer is switched between receive and transmit modes by means of a connection to the push-to-talk circuit of the transceiver.

GLB maintains a file on the necessary steps to adapt a wide variety of transceivers to channelized operation and provides such information when available. In special cases we will be happy to work with you to develop a procedure for your rig. If our files don't include data on your rig, we will need (1) the receiver first IF; (2) frequencies of existing crystals for both the receiver and transmitter; and (3) a copy of the transceiver schematic.

The Channelizer can be modified in various ways for special requirements. Call or write us concerning such applications.

OUTPUT FREQUENCIES:

GLB CHANNELIZER output frequencies in both the transmit and receive modes are: 6,8,12 and 24 MHz. For transceivers requiring signals in the 18, 36, 48 or 72 MHz (nominal) ranges, a frequency multiplier is provided. The multiplier stage mounts inside of the Channelizer cabinet and is a universal design -- that is, the same printed circuit board is used for all frequencies.

5 KHz steps are standard in the GLB 2 Meter Channelizer.

SPECIFICATIONS FOR GLB CHANNELIZERS

The GLB models 50, 400B, 220 and 450 Channelizers have been redesigned to use one universal main PC board (5124), and a universal VCO board (V-67). This makes it possible to buy a kit for any of the 4 bands and change to any other band. Option kits are available from GLB to make the changes.

<u>SPECIFICATIONS:</u>	6 METER	2 METER	220 MHz	450 MHz
<u>FREQUENCY RANGE</u>	50 to 54MHz	144-147.995	218-227	420-449.975
<u>FREQUENCY INCREMENTS</u>	5 KHz	5 KHz	10 KHz	25 + 50 KHz
<u>TRANSMIT-RECEIVE OUTPUT</u>	4,6,9,18 MHz	6,8,12,24	18	6,8,12,24
<u>FREQUENCY STABILITY</u>	.0005% from -10 to +50C			
<u>SPURIOUS OUTPUT (non harmonic)</u>	-60 db minimum			
<u>LOCK TIME</u>	Average 15 ms; worst case 152 ms.			
<u>INPUT POWER</u>	11 to 15 volts @ 400ma.			
<u>HUM & FM noise on carrier</u>	- 30 db below 5 KHz dev.Min at transmitter output			
<u>OUTPUT POWER</u>	Typical 10 milliwatts into a 50 ohm load			
<u>EXTERNAL CONNECTIONS</u>	B+ input, push to talk, receiver output, transmit out.			

CONTROLS: Two sets of frequency switches, each consisting of:
Megahertz 1-5 KHz
100 KHz
10 KHz

The low profile models use one set of frequency control switches for simplex operation. A repeater offset is incorporated for repeater operation.

CHANNELIZER OPERATION

There are two sets of frequency control switches and two selector switches on the panel of the Channelizer. The two sets of rotary switches control the actual frequency settings while the two-position selector switches determine which of the frequency settings is in actual use. A power on-off switch isn't necessary because the Channelizer is connected to the switched 12 volt line of the transceiver with which it is used.

SELECTOR SWITCHES

These are the two toggle switches located at the right and left sides of the panel. The left-hand switch, labeled "RX" is the receive mode selector. In the "up" position it causes the receiver frequency to be controlled by the top set of frequency control switches. In the "down" position the receiver frequency is determined by the lower frequency control switch settings. Similarly the transmitter can be controlled by either set of switches, depending upon the position of the "TX" switch.

This arrangement provides complete flexibility in the choice of frequencies.

For example, if both the TX and RX switches are up, you are transmitting and receiving on the same frequency, determined by the upper set of switch settings. You can transceive on the bottom set of controls by switching both selectors down. To receive on the top set and transmit on the bottom set, the RX switch is up and the TX switch is down.

For example, if you wish to operate via a repeater having an input frequency of 146.34 mhz and an output of 146.94 mhz you set the top row of controls to 146.34, the transmit selector up, and the bottom set of controls to 146.94 with the receive selector down. If at any time you would like to check the other fellow's unrepeated signal on '34, simply switch the receive selector up and you are listening on your own transmit frequency.

The dual frequency controls are convenient beyond repeater operation, too. Let's say you are in a contact on 146.94 simplex and you wish to change to 146.76. Assuming that you have been using the top row of switches for 146.94 operation, you can set the bottom row to 146.76 while transmitting or receiving. With both selectors up this action has no effect on your QSO. When ready to move, simply flick down the receive selector followed by the transmitter selector and you are there.

FREQUENCY SETTING

The actual setting of a frequency is simply a matter of adding the number of MHZ, hundreds of KHZ and tens of KHZ (plus either 5 khz or 0 khz with the 5 KHZ step adaptor) to 140 MHZ. The 140 MHZ figure is programmed into the Channelizer permanently, so the switch settings are added to it as follows:

EXAMPLE: To set 146.94 mhz. Add "6" on the MHZ switch, "9" on the 100 KHZ switch, and "4" on the 10 KHZ switch. $140 + 6 + .9 + .04 = 146.94$.

The top and bottom sets operate independently and identically.

BEFORE TRANSMITTING BE SURE TO CHECK THE POSITION OF THE TX SWITCH TO AVOID ACCIDENTAL INTERFERENCE or OUT-OF-BAND OPERATION!

INSTALLATION OF THE CHANNELIZER

Due to the widely varying requirements of different installations, cables are not supplied with the Channelizer. Output levels are sufficient to drive long coaxial cables to reach trunk-mounted equipment in a mobile installation or remote base station setups with the transceiver in other parts of a building. Cable impedance may be 50, 75 or 91 ohms. Don't use shielded audio cable.

A +12 volt power supply lead is required from the associated transceiver. This connection goes to the switch (and fused) side of the supply line in the transceiver so that they both turn on and off simultaneously. If unusually high levels of ripple or hash are present on the supply line additional filtering may be necessary.

The push-to-talk line on most transceivers is arranged such that it is grounded on transmit and a positive voltage (usually +12) on receive. This arrangement is directly compatible with the Channelizer, requiring a simple direct connection between the push-to-talk lines.

WARNING! Many transceivers operate relay coils with the PTT line. The inductive voltage transient created when relay coil current is broken can have sufficient energy to damage internal parts of the Channelizer. This potential problem can be solved by connecting a diode across the relay coil, as shown in Fig. 1c. Page 9.

The actual push-to-talk line requirements of the Channelizer are:

Transmit mode - a ground with no more than 1 volt at the PTT terminal.

Receive mode - at least 4 volts or open circuit. Do not exceed 50 volts.

If these requirements can't be met in the transceiver PTT line a transistor inverter or a separate relay can be added to key the Channelizer, as shown in fig. 1.

MATCHING TO TRANSCEIVER

Before connecting the Channelizer to the rig, measure the drive level at one of the multiplier stages with the rig operating on crystal.

With the Channelizer connected, the drive should be adjusted to the same levels as crystal.

Coupling the Channelizer into the oscillator circuits of your equipment involves exactly the same techniques you would need to couple in an external VFO. Coupling must be accomplished in such a way as to allow the crystal oscillator to behave as a buffer amplifier and not as an oscillator. Failure to achieve this result can cause spurious frequencies to be generated at the interface.

Many vacuum-tube oscillators are of the Pierce type, where the crystal is connected between the grid and screen. These circuits drive easily, simply by bypassing the screen to ground and coupling the Channelizer into the grid. However, since the Channelizer output impedance is low, a step-up circuit must be used to increase the drive voltage. As shown in fig. 2 there are several ways to accomplish this transformation.

Solid-state oscillators are usually of the Colpitts type as shown in fig. 3. Such an oscillator, when driven directly from a low-impedance source is likely to "squegg", causing spurious outputs in transmit and spurious responses in receive. This problem can be corrected by driving the oscillator thru a series element such as a resistor or inductor. Although the use of a resistor decreases the available drive power, it is possible to overdrive an oscillator with the Channelizer because of its high output power. The drive level can be adjusted by varying the value of the resistor. For maximum drive use a series inductor instead, adjusting its value for maximum output.

Any matching components should be mounted as close as possible to the crystal sockets to prevent RF pickup or radiation. The most reliable installation is achieved with directly soldered connections, but if you prefer a spare crystal holder can be used as a plug-in holder for the matching components. A ground lug, if needed can be mounted under a nearby chassis screw.

RECEIVER CONSIDERATIONS

The only necessary condition for Channelized operation in the receiver is to provide adequate drive at an appropriate frequency. The drive frequency doesn't necessarily have to be at the frequency band of the original crystal. For example, most receivers requiring a 46 mhz crystal work well when driven at 23 mhz, with the crystal oscillator acting as a doubler. In other cases a different multiplication ratio can be used. A Standard 806 requires a 15 mhz receive crystal, which is multiplied by 9 in the receiver. Again, if it is driven with 23 mhz it will just as well multiply by 6. Since the original scheme was to multiply first by 3, then by 3 again, the output of the first tripler was at 45 mhz. Driven by 23 mhz this stage becomes a doubler with the same nominal output frequency to drive the next tripler.

No changes have to be made in the rig because there isn't any tuned circuit at 15 mhz; thus it accepts drive at 23 mhz as well.

Similarly a Motorola 80D utilizes a quintupler after the crystal oscillator. If it is driven at 1/6th the injection frequency it still works, with the quintupler changed to a X6 multiplier. When changing multiplier ratios make sure that there isn't any tuned circuit at the input frequency to be changed. If there is, it will be necessary to pad it down to the new input frequency.

If you need help, be sure to send a copy of the oscillator-multiplier circuit of your particular rig, because some types of equipment have several variations in circuitry.

Channelizer output can be programmed to supply RF drive at 1/6, 1/12, 1/18 or 1/24 of the injection frequency [corresponding to the multiples 6, 12, 18 and 24 on the chart of page 6.]. Multiples of 8, 4, 3 or 2 can be accommodated by means of the frequency multiplier option. This extra stage mounts within the Channelizer case, providing the required output frequency at the rear jack.

TRANSMITTER CONSIDERATIONS

When properly matched to the Channelizer, the transmitter should operate just as it does with a crystal. Problems sometimes occur, however, and they must be diagnosed correctly in order to correct them.

The most common condition is "bassy" audio quality, sometimes accompanied by hum. These symptoms indicate RF leakage into the Channelizer from the transmitter. The Channelizer is well enough shielded to work in the field of transmitters running a kilowatt, but there are conducting paths that can cause leakage. Two of these possible paths are the PTT and the B+ lines, but these are effectively filtered with coaxial feed-thru capacitors.

RF can couple in via either the transmitter or receiver output jacks, however. All GLB Channelizers are supplied with low pass filters for the transmitter line. A low-pass filter passes the RF output of the Channelizer (at relatively low frequency) while rejecting the VHF RF. With some rigs additional filtering is needed. When a frequency multiplier is used in the transmitter output, the low-pass filter is not needed.

If the "bassy" syndrome persists, try disconnecting the receiver coax from the Channelizer. If the audio clears up, RF is being coupled into the Channelizer via the receive coax. A low-pass filter in the receiver line is the cure.

Another factor that increases the "bassy" effect is incidental AM on the transmitter. Incidental AM can be caused by poor transmitter alignment, insufficient drive or weak tubes. AM hum is common on base station equipment. You may have considerable AM hum on your rig without knowing about it, because it is inaudible on an FM receiver. Any RF leakage of the "hummy" carrier into the Channelizer will convert it to an FM hum that is audible! This condition can be corrected by improving the filtering on the transmitter power supplies.

Finally, hum can be produced from the Channelizer itself if the power supply isn't adequately filtered. Power supply ripple should be

held to less than 1.5 volts peak-to-peak at the B+ terminal.

NOTE: Hum can be picked up in the VCO circuits if the covers are left off. Before testing with a transmitter make sure the VCO shield is in place and the cover is securely mounted to the Cabinet with all four screws.

A good test of proper interfacing is to compare the audio quality and RF power output of the transceiver with a crystal to that with the Channelizer (set to the same frequency as the crystal). If there is no change in power output and little or no change in audio level or quality, you are finished! If output power either decreases or increases it could indicate a squegging oscillator and spurious outputs.

The transmitter output of the Channelizer can be programmed to the same multiples previously described under "Receiver considerations".

USE OF CRYSTALS WHILE CHANNELIZER IS CONNECTED

Power to the Channelizer should be removed when using the transceiver on the crystal positions to prevent interference.

BASE STATION POWER SUPPLY

Fig. 6 shows a suggested power supply circuit for operating the Channelizer on AC mains. Any supply may be used with output voltage between 11 and 15 volts under load, with less than 1.5 volts peak-to-peak ripple.

OUTPUT PROGRAMMING CONNECTIONS GLB V-67 VCO BOARD

Lettered connection points are on the trace side of the V-67 board.

L and M are on the Main 5124 board. If your transceiver program requires connection to L or M install an 8" length of wire at the proper point on the main board when doing the main board wiring. This wire can be connected to the V-67 board during the final chassis wiring.

RECEIVER FREQUENCY MHz	TRANSMITTER FREQUENCY MHz	JUMPERS
23	24	A-G, A-B, remove Z12
23	12	A-B, E-G, D-gnd, J to L
23	8	A-B, F-G, D-E, H to L
23	6	A-B, F-G, H to L
11	24	A-G, B-F, D-gnd, J to M
11	12	B-E, F-G, D-gnd
11	8	C-B, D-F, E-G, J to L
11	6	C-B, E-G, J to L

Frequencies in the 18, 36, 45 and 72 MHz range are obtained with a multiplier option that fits within the Channelizer case.

THEORY OF OPERATION

Fig. 8 shows a block diagram of the GLB. A signal is generated in the 20 to 25 mhz frequency range by a voltage-controlled oscillator (VCO). Its output is amplified and fed to a mixer. In the transmit mode the mixer also receives a 25 mhz signal from the master oscillator. The resulting mixer output frequency is equal to the difference between the VCO frequency and the 25 mhz reference signal. For operation in the 144 to 148 mhz range the VCO operates at $1/6$ of the output frequency of the transceiver or 24 to 24.6667 mhz. The resulting IF output from the mixer is in the range of 1.000 to 0.3333 mhz. This IF signal is low-pass filtered to eliminate the undesired mixer output products, amplified and fed to a programmable frequency divider.

A digital programmable frequency divider consists of a series of flip-flops suitably interconnected, that can be programmed by combinations of voltages on its control lines to divide by any desired number. In the Model 400B the programmable divider can be set to divide by any number between 1 and 1000. Ten control lines are used to program it to numbers between 201 and 600, the range of ratios actually used to cover the 2 - meter band.

The purpose of this divider is to divide the IF down to a reference frequency of $1 \frac{2}{3}$ khz. If, for example, it is set to divide by 300, the output would be $1 \frac{2}{3}$ khz only for an IF input of $300 \times 1 \frac{2}{3} = 500$ khz. Working back to the mixer, this IF could occur only if the VCO was on a frequency of $25 - 0.5 = 24.5$ mhz. This VCO frequency corresponds to an output frequency at the transmitter of $6 \times 24.5 = 147.00$ mhz.

The foregoing assumes that the VCO was originally on the right frequency to make the programmable divider output equal to $1 \frac{2}{3}$ mhz. However, if the VCO starts out on some other frequency, the output of the programmable divider will also be wrong. A frequency comparator circuit is employed to correct this error.

The frequency comparator compares the frequency of the programmable divider output against a $1 \frac{2}{3}$ khz reference frequency and responds to their relationship by adjusting the DC tuning voltage of the VCO. If the two frequencies are identical the tuning voltage is held steady. If the output of the programmable divider is higher or lower than the $1 \frac{2}{3}$ khz reference frequency, the frequency comparator responds by adjusting the tuning voltage up or down, in such a way as to correct the error. The end result is always to equalize the frequency of the programmable divider to the $1 \frac{2}{3}$ khz reference signal, because once this goal is achieved the VCO will have been automatically adjusted to the dialed frequency (divided by 6, of course).

The two reference frequencies needed in the process are both derived from the same source; the 25 mhz master crystal oscillator. In order to obtain $1 \frac{2}{3}$ khz, the 25 mhz frequency is divided by 15,000 in a chain of flip-flops permanently programmed to this ratio.

With both reference frequencies derived from the same source, the final output frequency is only dependent upon the accuracy of that source and the settings of the switches, which determine the ratio of the programmable divider.

Thus, the loop is completed. If the VCO frequency doesn't correspond to the frequency dictated by the switch settings, the output of the programmable divider can't be at $1 \frac{2}{3}$ khz. This error is detected by the frequency comparator, which responds by retuning the VCO frequency.

Actually, the comparator has two modes of operation; that of a frequency discriminator when a large frequency difference occurs and that of a phase detector when the signals it sees are nearly identical. Since the final frequency correction is based upon phase information the frequency error goes to zero. In fact, the type of phase comparator used actually reduces the phase error to zero! Thus the synthesizer output frequency is related by an exact mathematical expression to the reference crystal oscillator frequency:

VCO output freq. = $25 - N/600$ [N is the programmable divider ratio]
and:

Transceiver output frequency is six times the VCO frequency, or:

$$F_{\text{trans}} = 150 - N/100, \text{ in MHz.}$$

When N changes in integer steps, the output therefore changes in steps of 1/100 mhz, which is 10 khz. Thus the position of the frequency control switches (which determine N) determines the output frequency of the transmitter and can be calibrated in terms of frequency output.

For operation in the receive mode the only difference is that a different frequency is injected into the mixer in place of the 25 mhz reference frequency used on transmit. Assuming that a 24 mhz reference is substituted;

$$\text{VCO freq} = 24 - N/600$$

and:

$$F_{\text{inject.}} = 6(\text{VCO freq}) = 144 - N/100$$

If N=300, the transmit output would be $150 - 300/100 = 150 - 3 = 147$ mhz. For the same switch settings, but the receive mode the local oscillator injection frequency is:

$$F_{\text{inject.}} = 144 - 300/100 = 144 - 3 = 141 \text{ mhz.}$$

This frequency is 6 mhz lower than the corresponding transmitter output frequency, so that if a receiver having a 6 mhz first IF were being used it would receive the same frequency as was being transmitted. It turns out that the relation for determining the frequency of the offset crystal is:

$$F_{\text{offset}} = (150 - \text{RCVR 1st IF})/6, \text{ in MHz.}$$

These examples were for the case where both the receiver and transmitter multiply the input frequency by 6. Other multiples are accommodated by dividing the VCO output frequency by 2, 3 or 4. Choice of this divide ratio is made by wiring the jumpers according to Table 2. As long as the net multiple from the VCO to the final output frequency is 6, frequency step spacing doesn't change. For example, consider a transmitter with frequency multiplication from the crystal frequency to the output frequency of 24 (using 6 mhz crystals). For this type of equipment the Channelizer is wired to divide the VCO output by 4 to obtain 6 mhz, which is then multiplied by 24 in the transmitter. $24/4=6$, which is the desired ratio.

HIGH-SIDE INJECTION MODIFICATION

The standard Channelizer is equipped for low-side injection. This modification converts it to high-side injection. High-side injection requires a change in the offset crystal frequency, using the formula:

$$F_{\text{offset}} = (150 + \text{RCVR 1st IF})/6, \text{ in MHz}$$

instead of the original formula.

Fig. 1 (a) Circuit for converting positive-going push-to-talk circuits to Channelizer PTT. (b) Use of a relay permits any circuit to be used, as long as the relay can be operated. (c) Showing a "de-spiking" diode across the normal changeover relay in transceiver, when Channelizer PTT line is directly connected.

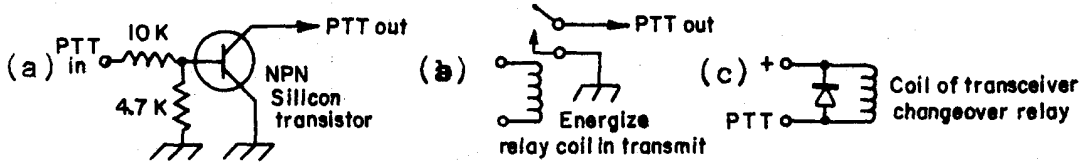

Fig. 2. Impedance step-up circuits for vacuum-tube equipment. (a) tapped tuned circuit, (b) link-coupled tuned circuit, (c) L-network. In each case C represents the internal capacitance of the transmitter oscillator circuit. The inductance value is adjusted to resonate with the circuit capacitance at the Channelizer output frequency, and addition of capacitance is not recommended.

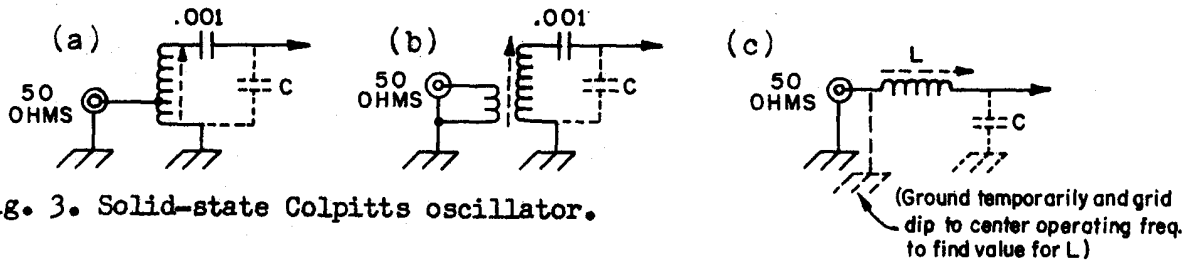

Fig. 3. Solid-state Colpitts oscillator.

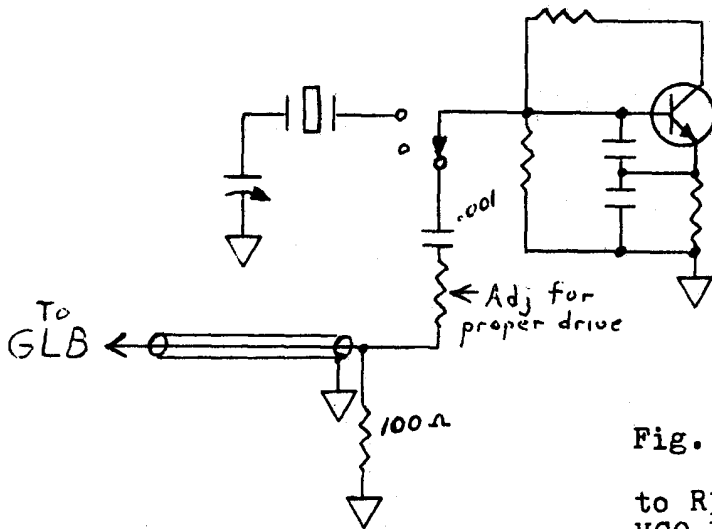

Fig. 4. Low-pass filter circuit. $L = 1 \text{ uh}$. $C1 \ \& \ C2 = 47 \text{ pf}$.

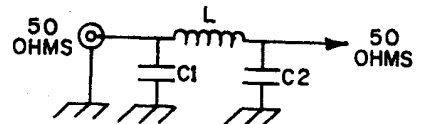

Fig. 5. Direct FM connections.

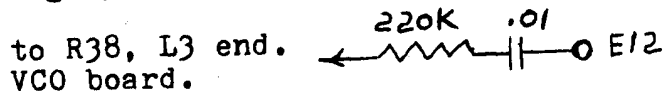
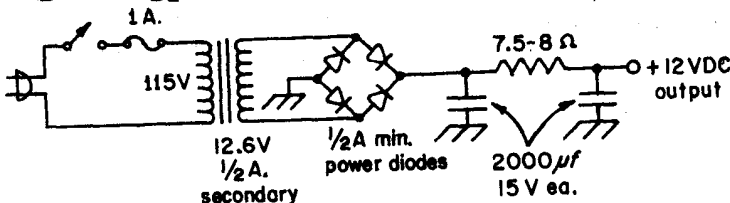

Fig. 6 Suggested circuit for a base-station power supply for the Channelizer.



GLB MODEL 400B CHANNELIZER

IMPORTANT! BEFORE PROCEEDING, READ THIS!

Check the parts against the parts list before doing anything else. If there are any shortages, notify GLB immediately. Be sure that you have checked every package and envelope before reporting a shortage.

While you are checking the parts, now is a good time to sort and arrange them in an orderly manner of storage so that they are easily accessible while you are building your GLB. Your XYL should have a couple of cup-cake or muffin pans in the cupboard that you can borrow for awhile. If not, a trip to your nearest 5 & 10 or K-Mart can get you a couple for very little money. They make the best small parts storage during kit construction of anything that we know.

Checking the parts will also help you to familiarize yourself with them. From time to time, reasonable substitutions may be made for the parts specified. Such differences are usually obvious and shouldn't present any difficulties. If you have trouble identifying a part, it may become clear by the process of elimination when you are finished. Check off each part in the spaces provided on the parts list.

Some kit builders like to check all of the capacitors for shorts before they start construction. We have had very few troubles of this kind, and the practice hardly seems necessary. **DO NOT TEST THE TANTALUM CAPACITORS WITH AN OHMMETER**, as the battery in the meter will burn them out!

It can't be overemphasized that you follow the step-by-step instructions implicitly. The sequence of steps is designed to facilitate construction and to maximize the chances of "first-time" operational success. A space is provided to check off each step when completed.

When the instructions call for soldering a part in place on a printed circuit board, it is to be assumed that any excess lead length on the trace side of the board should be clipped off. Leave a stub of about 1/10th inch below the board when clipping the leads.

The most frequent problems with kits returned to the factory for repair are: **POOR SOLDERING AND FAILURE TO READ AND FOLLOW INSTRUCTIONS**. Most kit builders do not use enough heat on the sockets and the large ground traces of the boards. We recommend a 40 watt iron with a 1/8th inch screwdriver tip. Use a good grade of Rosin core solder such as "Kester 44" or "Ersin Multicore". Use 1/32nd inch diameter solder.

In addition to the normal hand tools that you will use during construction of your kit, we recommend that you have a magnifying glass. After each solder connection, it will allow a better inspection with even the sharpest pair of eyes, and will disclose any tiny solder bridges between traces on the board. The best available tool for removing surplus solder is a spring operated solder-sucking tool.

GLB MODEL 400B CHANNELIZER

Molded Tantalum capacitors are polarized electrolytics and have to be installed with the right polarity. They may have a + sign or a color stripe on one side, or even a dimple built into them to show the positive side.

For purposes of your GLB kit, capacitor identification can best be accomplished by checking and sorting the components against the parts list. The number of a given value found, when checked against the list, should clear up any question that you might have about its identification.

The easiest way to find trouble in a kit is to avoid it. Even if it takes twice as long to build the kit, you are still way ahead because trouble-shooting is a slow process. Check each step as you make it. Use the magnifying glass to inspect the connection, then recheck the value of the component installed.

Keep your work area uncluttered and always have good lighting conditions. Do not work on your kit if you become over-tired. This will only lead to mistakes, and will just add to your eventual completion time.

TEFLON COAX costs more, but it is easier to strip! Follow these simple steps:

1. Score outer jacket with knife.
2. Pull off outer jacket.
3. Tin braid and score with knife.
4. Bend braid back and forth. It will break off and you can pull it off.
5. Score center conductor insulation and strip. Do not nick the conductor.

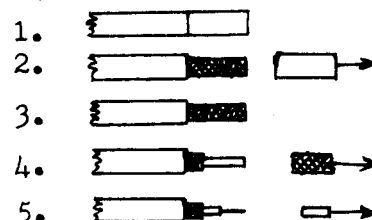

All ceramic and mylar capacitors should be mounted with the shortest possible leads and the capacitor body against the top of the board as closely as possible.

Capacitors are identified in several ways. Some are marked with the value printed in uf (microfarads), others in uuf (the old micro-microfarad symbol which has been newly adopted to be picofarad, or pf), and still others are coded as follows:

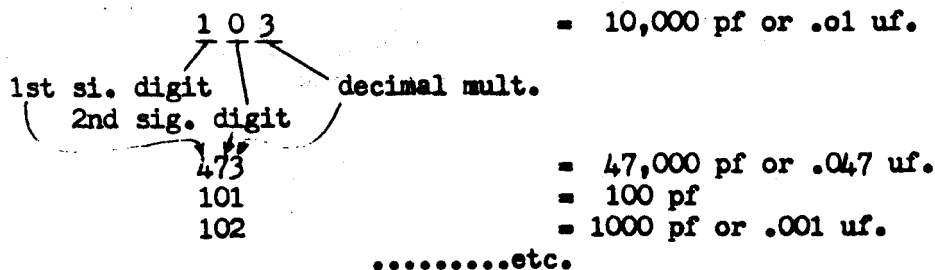

RESISTOR COLOR CODE:

- 1 brown
- 2 red
- 3 orange
- 4 yellow
- 5 green
- 6 blue
- 7 violet
- 8 gray
- 9 white
- 0 black

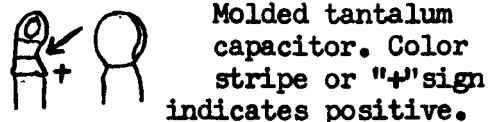
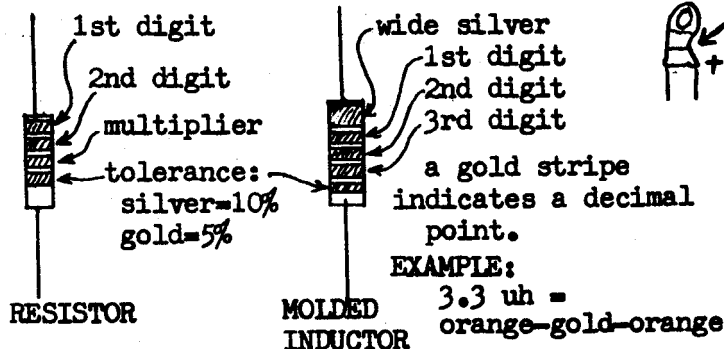

Aluminum and tantalum types are both polarized electrolytic capacitors.

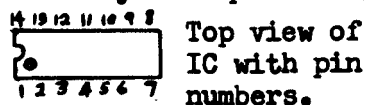

Top view of IC with pin numbers.

GLB MODEL 5124 PARTS CHECK LIST -- 2 METERS 300A

<u>RESISTORS</u>				QTY		<u>COILS</u>				QTY	
100	ohm	1/2W	10%	1	()	Slug tuned		5	()		
100	ohm	1/2W	10%	2	()	3.3uh (Violet)		2	()		
220	Ohm	1/2W	10%	2	()	47uh (Green)		1	()		
330	"	"	"	1	()						
470	"	"	"	3	()						
680				2	()						
1K				13	()						
1.5K				1	()						
1.8K				2	()						
2.2K				5	()						
3.9K				1	()						
4.7K				4	()						
10K				20	()						
47K				7	()						
18K	Ohm	1/2W	5%	2	()						
9.1K	Ohm	1/2W	5%	1	()						
390	ohm	"	"	1	()						
<u>CAPACITORS</u>						<u>SWITCHES</u>					
33pf		Ceramic		1	()	4-position BCD		1	()		
39pf	N1500	"		3	()	10-position BCD		2	()		
50pf	N5600	"		4	()	Toggle (SPDT)		3	()		
100pf		"		3	()						
150pf		"		3	()						
180pf		"		1	()						
220pf		"		2	()						
470pf		"		4	()						
150J	N750	"		2	()						
.001uf		"		23	()						
.01uf		"		6	()						
.05uf		"		3	()						
.005uf		Mylar		2	()						
.01uf		"		1	()						
.05uf		"		2	()						
1uf		Tantalum		3	()						
22uf		"		1	()						
22uf		Aluminum		3	()						
470uf		"		1	()						
5-30pf		Trimmer		1	()						
.001uf		Feedthru		2	()						
<u>DIODES</u>						<u>CIRCUIT BOARDS</u>					
1N914	or 1N4148			5	()	5124 (Main)		1	()		
MV2209				1	()	V-67 (VCO)		1	()		
<u>TRANSISTORS</u>						601 (Offset)		1	()		
2N3904				16	()						
MPS3563				1	()						
40841	or MFE122			1	()						
<u>INTEGRATED CIRCUITS</u>						<u>HARDWARE</u>					
74176				6	()	3/8" nuts		3	()		
74177				1	()	3/8" Lockwashers		3	()		
7473				1	()	3/8" spacers		7	()		
74H73				1	()	4-40x1/2" screws		17	()		
7400				2	()	#4 Lockwashers		11	()		
4044P				1	()	6-32x1/2" screws		4	()		
74S00				1	()	4-40x3/4" spacers		2	()		
7805				1	()	Rubber feet		4	()		
						Main Chassis		1	()		
						Cover (Black)		1	()		
						VCO cover		1	()		
						<u>CRYSTALS</u>					
						25.00000 MHz		1	()		
						IF offset (custom)		1	()		
						25.10000 MHz RPT HI x 4		1	()		
						24.90000 MHz RPT LO x 3		1	()		
						<u>OUTPUT FILTER</u>					
						Mounting strip		1	()		
						1uh choke (Red)		1	()		
						47pf Ceramic		2	()		
						<u>WIRE & CABLE</u>					
						Teflon coax		12"	()		
						Ribbon cable		8"	()		
						Black, Yellow, #24		12"	()		
						Red, Orange, #24		20"	()		
						Brown #24		20"	()		
						White #24		50"	()		
						<u>MISCELLANEOUS</u>					
						Knobs		3	()		
						IC sockets		13	()		
						Phono jacks & hardware		2	()		
						Bulbs (4 volts)		3	()		
						Illumination Strip		1	()		
						Rear panel label		1	()		
						Instruction manual		1	()		

MAIN CIRCUIT BOARD ASSEMBLY -- GLB 5124

The following three pages are to be used as a reference for the main (5124) circuit board assembly. Each page shows the board layout and a list of parts to be installed. Parts should be installed and soldered on an item by item basis.

CHECK OFF EACH ITEM AS COMPLETED. BE SURE TO INSTALL THE REQUIRED QUANTITIES. Several option kits are available for the GLB Channelizer. We advise you to read the instruction sheets for the option kits before starting construction of the Channelizer.

When installing components on the PC boards, it is important that they be mounted as close to the board as possible. Insert the components in the board and bend the leads on the trace side about 45 degrees as shown below, Fig. 1. Solder the leads and cut off excess lead length.

Before starting assembly of the 5124 board, the reference divider chain must be programmed for the correct reference frequency -- 1.6667 KHz. Refer to Fig. 2, and complete the following steps: Trace side of board.

- () 1. Cut trace as shown above Z2.

FIG. 1.

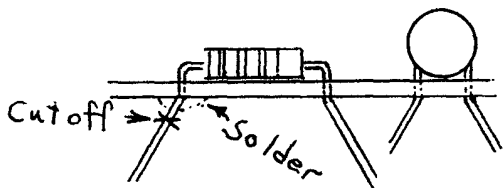
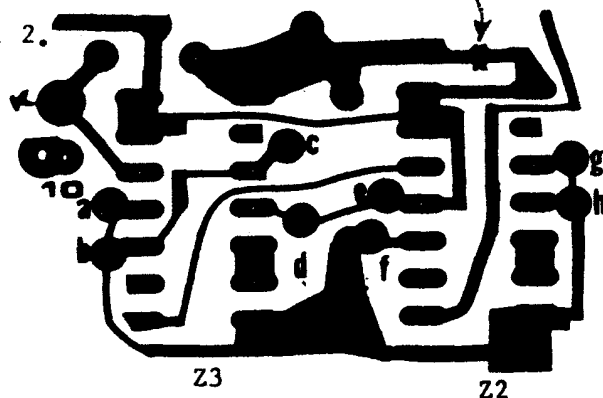
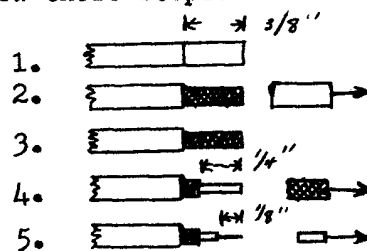

FIG. 2.



TEFLON COAX is more expensive but it is easier to use! Follow these steps:

1. Score outer jacket with knife (not braid).
2. Pull off outer jacket.
3. Tin braid all around and score with a knife.
4. Bend braid at score mark. It will break cleanly and you can pull it off.
5. Strip center conductor in the normal manner. Don't nick the center conductor.



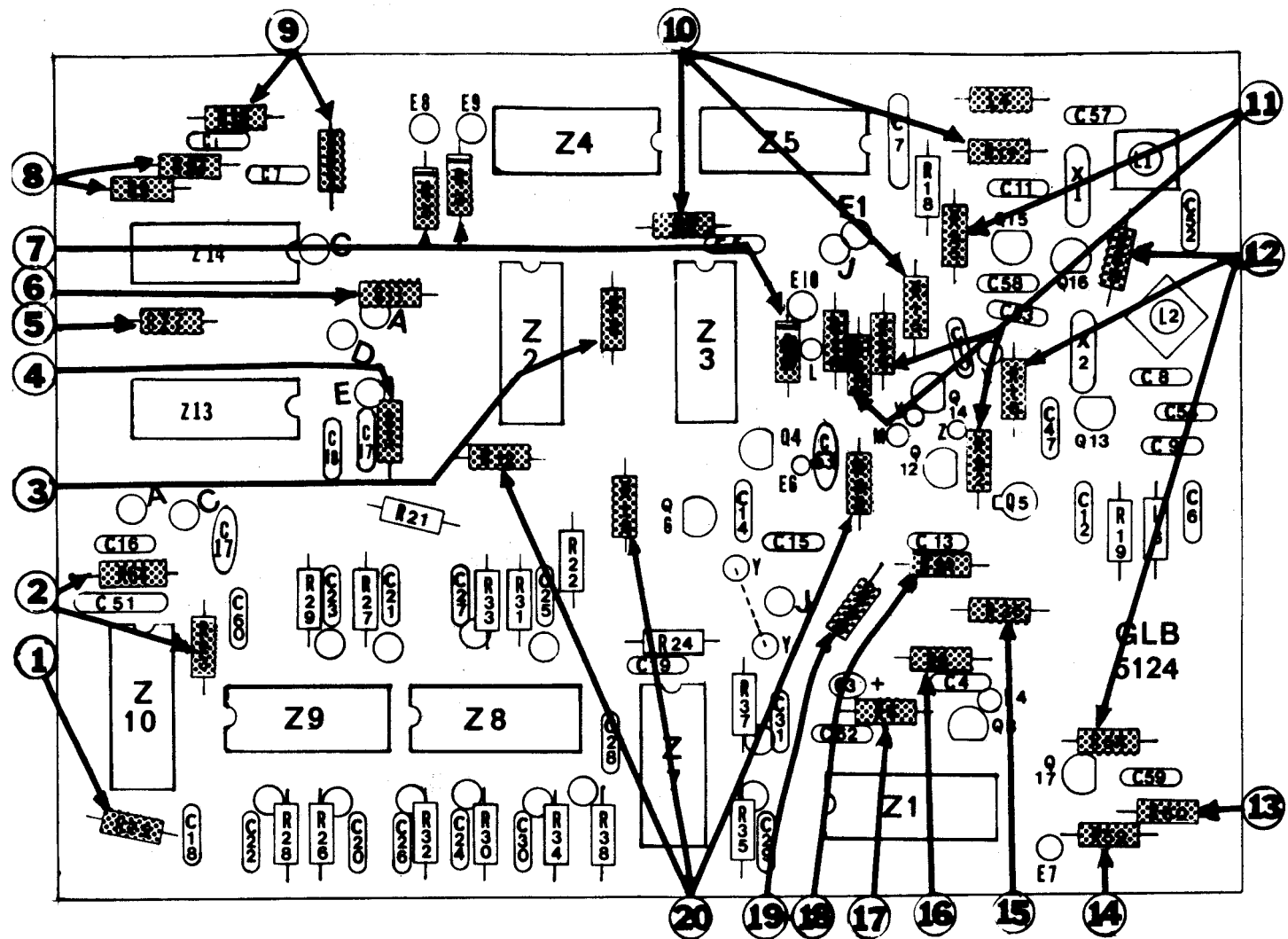

Item	Value	Qty	Chk
1	1.5K	1	
2	2.2K	2	
3	2.2K	1	
4	Not Used	0	
5	10K	1	
6	470	1	
7	1N914	3	
8	1.8K	2	
9	1K	2	
10	1K	3	

Item	Value	Qty	Chk
11	10K	4	
12	4.7K	3	
13	100	1	
14	390	1	
15	1K	1	
16	10K	1	
17	3.9K	1	
18	1K	1	
19	470	1	
20	4.7K	3	

All resistors are $\frac{1}{4}$ W 10% unless noted.
 All capacitors are disc ceramic unless noted.
 All electrolytic and tantalum capacitors
 are 16 volts minimum.

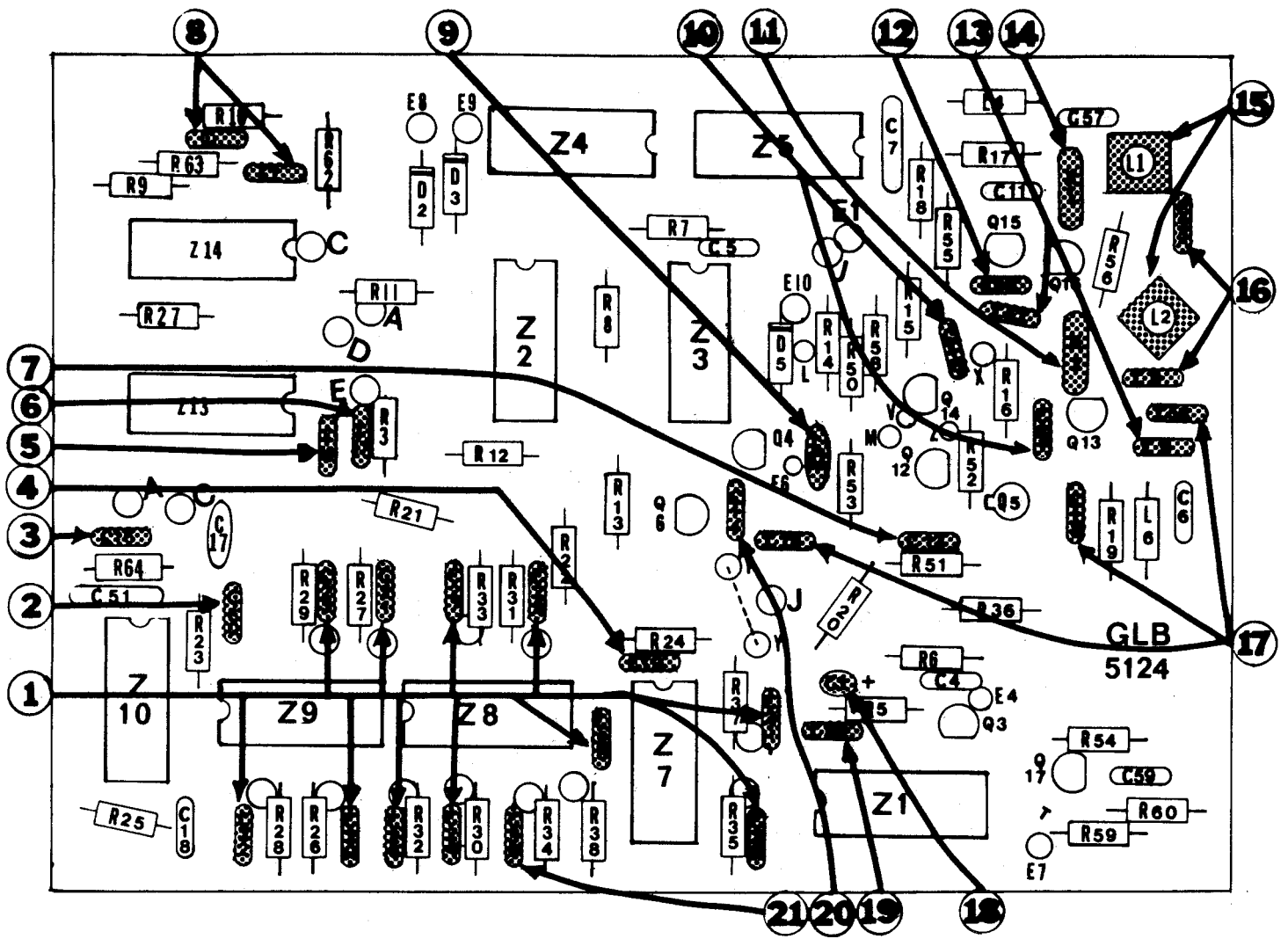

Item	Value	Qty	Chk
1	.001uf	11	
2	39 N1500	1	
3	150	1	
4	150	1	
5	.001uf	1	
6	Not Used	0	
7	100	1	
8	220	2	
9	.01	1	
10	.001uf	2	
11	Note 1	1	

Item	Value	Qty	Chk
12	180	1	
13	470	2	
14	Note 1	1	
15	Coil	2	
16	50 N5600	2	
17	.01uf	3	
18	1uf Ta	1	
19	33	1	
20	100	1	
21	Not Used	0	

ITEM 15: SLUG TUNED COILS:
Board traces are designed to
accept any orientation.

NOTE 1:
Crystals must be $\frac{1}{4}$ "
up from the board.

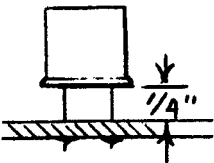

X1 is reference
See parts list.

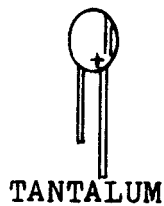

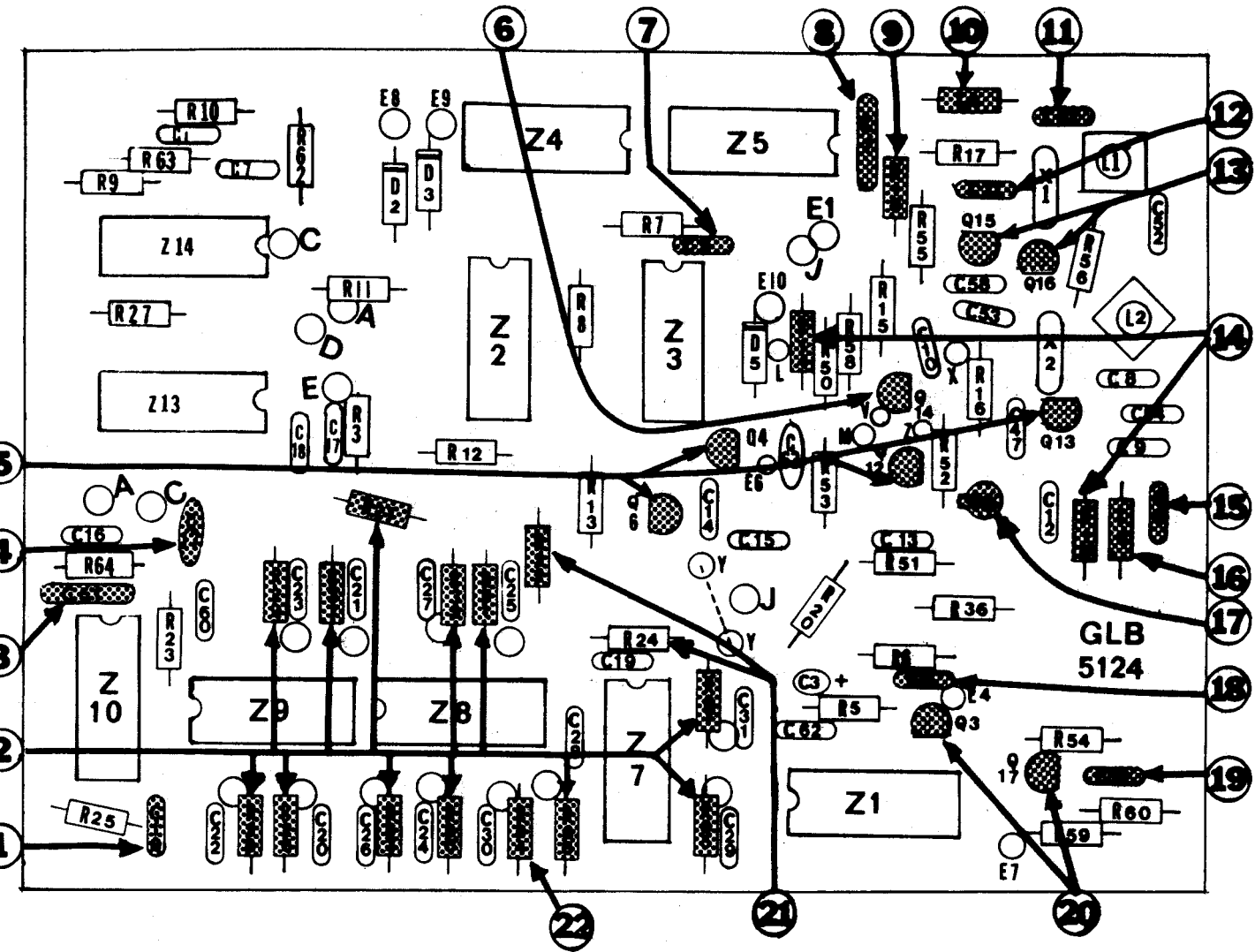

Item	Value	Qty	Chk	Item	Value	Qty	Chk
1	100	1		12	39 N1500	1	
2	10K	12		13	2N3904	2	
3	.05uf	1		14	680	2	
4	.05uf	1		15	39 N1500	1	
5	2N3904	4		16	3.3uh	1	
6	MPS3563	1		17	40841	1	
7	150	1		18	.05uf My	1	
8	.05uf	1		19	.001uf	1	
9	220	1		20	2N3904	2	
10	3.3uh	1		21	1K	2	
11	.001uf	1		22	Not Used	0	
				23	Note 1	11	

ITEM 17: 40841 or MPE122.
 Note the position of the tab and spread the leads to meet the holes on the board. Press the transistor toward the board to reduce the lead lengths but not so hard as to short the leads to the case.

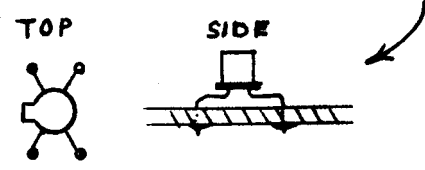

Installing 2N3904 transistors:
 Trim the leads of the transistor to 1/4" from the transistor body. Install the transistor **FLUSH TO THE BOARD**. Bend each lead so that it lies on the proper trace and solder.

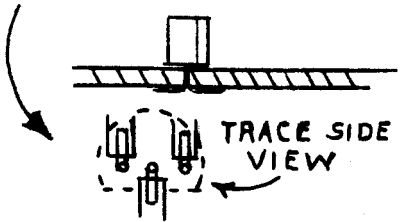

NOTE 1. Item 23: IC sockets.
 Note that a diagonal section is molded in the corner of the IC socket. This corner of the socket is pin 1 of the IC.

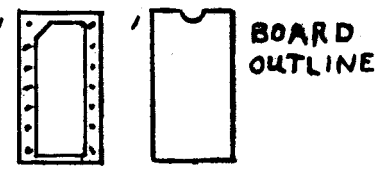

Proceed to the VCO assembly instructions.

Using the VCO pictorial as a guide, insert and solder the components on an item by item basis. CHECK OFF EACH ITEM AS COMPLETED.

When the component installation is complete, inspect the board carefully for correct component placement and soldering.

TRANSMIT AND RECEIVE FREQUENCY PROGRAMMING:

Lettered connection points are on the trace side of the VCO board. Refer to the programming chart on page 6. Using insulated wire, connect the proper points on the trace side of the VCO board for the receive and transmit frequencies required for your rig.

Mount the VCO cover on the board, making sure that the holes in the cover are over L3 and C37 so they can be adjusted with the cover on. Use the 4-40x $\frac{1}{4}$ " screws and washers, through the cover and board and the 4-40x $\frac{3}{8}$ " spacers on the trace side of the board.

Prepare the following lengths of coax cable as shown below:
NOTE: See stripping instructions on page 2.

- () 3 inch
- () 4 "
- () 5 "

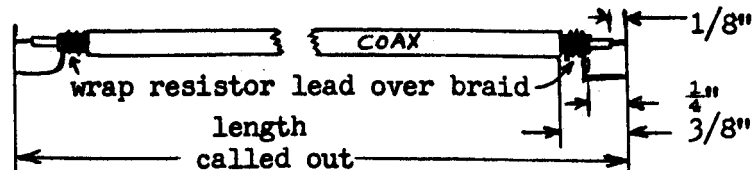

Wrap resistor lead as shown and solder to braid.

Wrap resistor lead on one end of the 5" length.

- () Refer to the VCO pictorial and connect the center conductor from one end of the 3" length of coax to E11.
- () Refer to the VCO pictorial and connect the center conductor from one end of the 5" length of coax to E12.

Set the 4" length of coax aside. This will be used in the main board wiring.

After the coax is installed at E11 and E12, set the VCO assembly aside. The next step will be the assembly and wiring of the frequency switches.

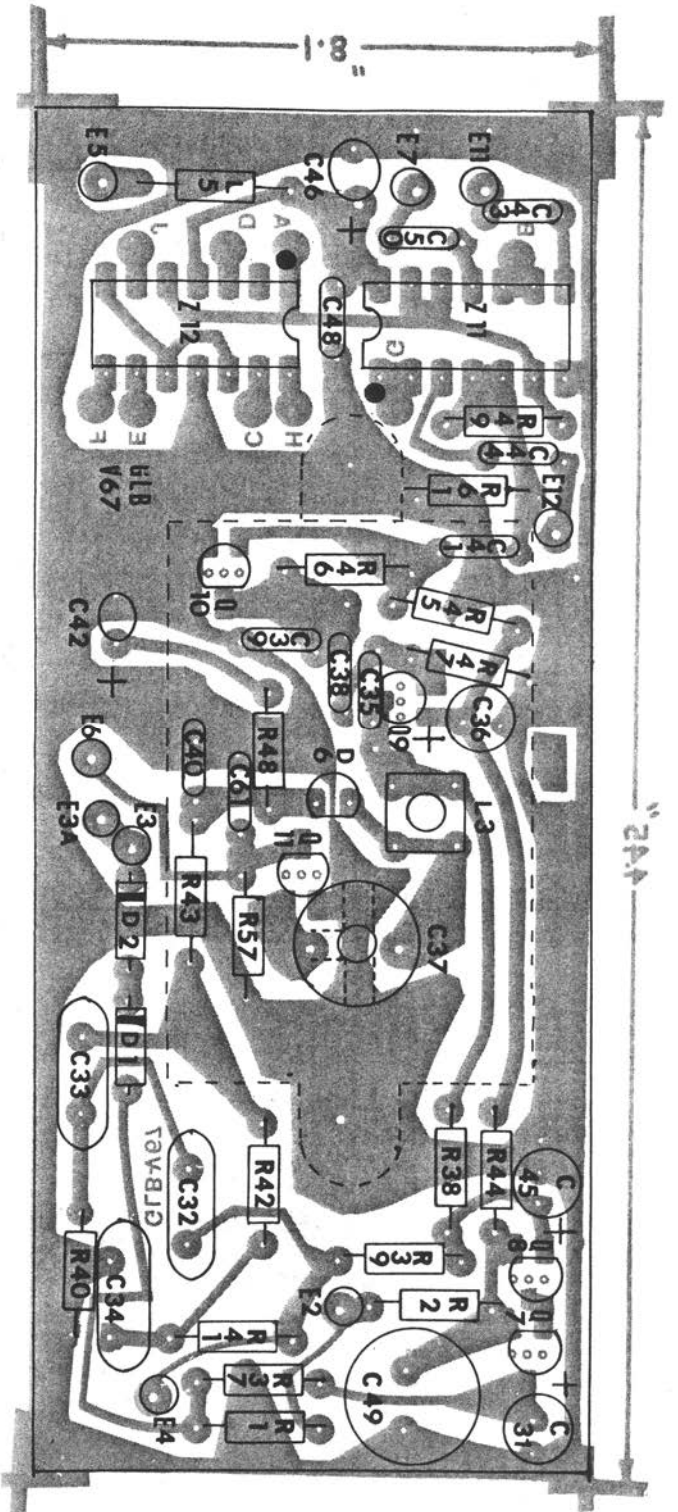

Using the VCO pictorial as a guide, insert and solder the components on an item by item basis. CHECK OFF EACH ITEM AS COMPLETED.

Item	Part #	Value	Chk
1	L5	47uh (Green)	
2	R49	1K ½W 10%	
3	R61	1K	
4	R45	2.2K	
5	R47	2.2K	
6	R46	4.7K	
7	R48	10K	
8	R57	1K	
9	R43	4.7K	
10	R44	100 Ohm	
11	R38	1K	
12	R39	4.7K	
13	R2	220	
14	R37	10K	
15	R1	330	
16	R40	9.1K ½W 5%	
17	R41	18K ½W 5%	
18	R42	18K ½W 5%	
19	Q9,10,11,8,7	2N3904	

Item	Part #	Value	Chk
20	D6	MV2209	
21	D1, D2	1M,148 or 1M914	
22	Q43, Q50	.001uf	
23	Q44, Q41	.001uf	
24	Q46	22uf Tantalum	
25	Q48	.01uf	
26	C35, C38	150 N750	
27	C39	.001uf	
28	Q42	1uf Tantalum	
29	C61	.01uf	
30	C40	.05uf Mylar	
31	C36,45,3	22uf Aluminum	
32	Q49	470uf Aluminum	
33	C32, C33	.005uf Mylar	
34	C34	.01uf Mylar	
35	C37	5-30 Trimmer	
36	L3	Slug tuned coil	
37	Z11,12	IC sockets	
38		2 ½" wire from E5 to E3A	

MAIN CHASSIS ASSEMBLY

Refer to the main chassis assembly pictorial.

Install the two feedthru caps and the two phono jacks as shown.

Install the four main board mounting spacers, "A".

Before mounting Z6, complete the following steps:

- () 1. Bend the leads of Z6 as shown.
- () 2. Form a loop at the end of each lead.
- () 3. Connect a luf tantalum capacitor as shown, plus to Z6-B, minus to Z6-C.
SOLDER "C" ONLY.
- () 4. Install Z6 on chassis at the left rear multiplier mounting hole as shown. Use a 4-40x $\frac{1}{4}$ " screw and #4 lockwasher. Use a 4-40x $\frac{3}{8}$ " spacer as a nut.
- () 5. Cut a 3 $\frac{1}{2}$ " length of red wire. Strip and tin $\frac{1}{4}$ " each end. Connect to the lower feedthru capacitor and solder.
- () 6. Connect the other end of this wire to Z6-B. DO NOT SOLDER.

FREQUENCY SWITCH ASSEMBLY

For the following steps refer to the switch assembly pictorial. Page 34.

The silkscreened front panel is installed with the frequency switches.

If you are installing the Preset Option, the Switch hole will have to be drilled before the panel is installed.

- () 1. Install the 4-position switch in the hole marked MHz.
- () 2. Install the 10-position switches in the remaining holes.
- () 3. Install S4, S5, & S6. To avoid scratching the panel, tighten the nuts behind the panel.

Connect the switch commons as follows: Note--10-position switches have two common lugs. Both lugs must be soldered on each switch.

- () 1. Cut a 2 $\frac{1}{4}$ " length of White wire. Strip each end $\frac{3}{8}$ " and tin. Connect from S1-CC, NS, to S2-CC, NS. (NS) means no solder.
- () 2. Cut a 2" length of White wire. Strip one end $\frac{3}{8}$ " and tin. Strip the other end $\frac{1}{4}$ " and tin. Connect from S2-CC, Solder, to S3-C, Solder.
- () 3. Cut a 6 $\frac{1}{4}$ " length of Orange wire. Strip each end $\frac{1}{4}$ " and tin. Connect one end to S1-CC, Solder.

If your rig requires the frequency multiplier, assemble it at this time, using the instructions that come with the multiplier kit.

The multiplier mounts on the two "B" spacers at the rear of the chassis.

ILLUMINATION KIT ASSEMBLY

For the following steps refer to the pictorial on page

Find the 3 bulbs, 100 ohm $\frac{1}{4}$ W resistor and the etched illumination strip.

- () 1. Cut and strip the leads on the bulbs as shown in the pictorial. USE EXTREME CARE when cutting or stripping the leads.
- () 2. Solder the $\frac{1}{4}$ W resistor as shown.
- () 3. Solder the leads of the bulbs as shown.
- () 4. Cut a 6" piece of white wire. Strip each end $\frac{1}{4}$ " and tin. Connect one end to the strip as shown.
- () 5. Cut and strip an 8 $\frac{1}{4}$ " length of red wire. Connect to strip at the 100 ohm resistor.
- () 6. Pull off backing from adhesive on rear of strip and carefully install on panel as shown. The bulbs can be oriented on top of the switches to give the proper amount of illumination.

The selectable offset board must be built and installed on the main board.
Use the following instructions:

- () 1. Using the 601 parts layout as a guide, insert and solder all of the components.
- () 2. Cut a 3" length of white wire. Strip 1/8" each end. Connect one end to pad "X" on the 601 board.
- () 3. Cut and strip an 8" length of Yellow wire. Connect one end to the pad marked "L" on the 601 board.
- () 4. Cut and strip an 8" length of Black wire. Connect one end to the pad marked "H" on the 601 board.
- () 5. Install the two 4-40x3/4" standoffs on the 5124 board, using 4-40x1/2" screws. The standoffs mount near L4 and C13.
- () 6. Mount the 601 board on the standoffs with 4-40x1/2" screws.
- () 7. Connect the white wire from Pad "X" on the 601 board to Pad "X" on the main board and solder.

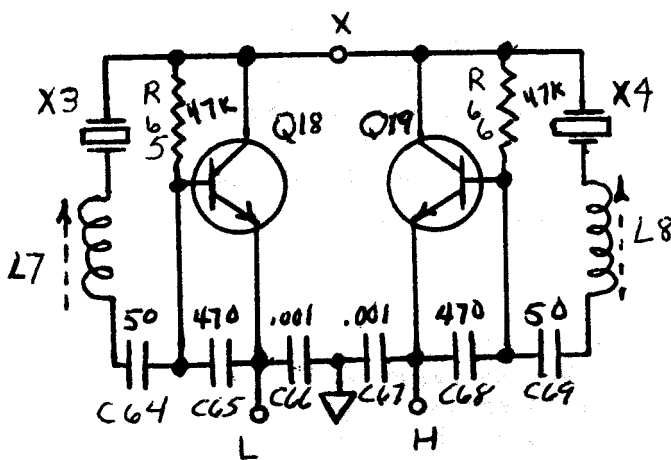
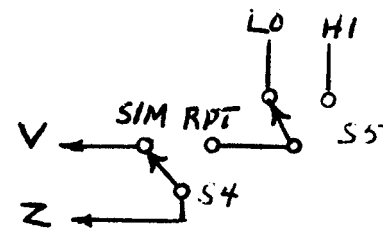
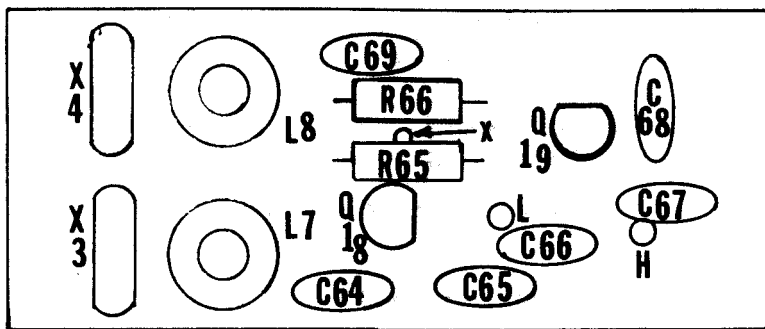

Repeater offset crystal oscillator frequency adjustment will be done after step 5 on page 27.

1. Connect a frequency counter to the transmit output jack.
2. Calculate the frequency needed for your transceiver for HI and LO offset.
3. Set the RPT/SIM switch to the RPT position.
4. Apply power and ground the PTT line. Set the LO/HI switch to HI and set output frequency with L2. Set HI/LO switch to LO and set output frequency with L1.

Formula - 600 KHz offset --- $150 - .6 \text{ MHz}/6 = \text{Low side offset.}$
 $150 + .6 \text{ MHz}/6 = \text{High side offset.}$

MAIN CHASSIS ASSEMBLY

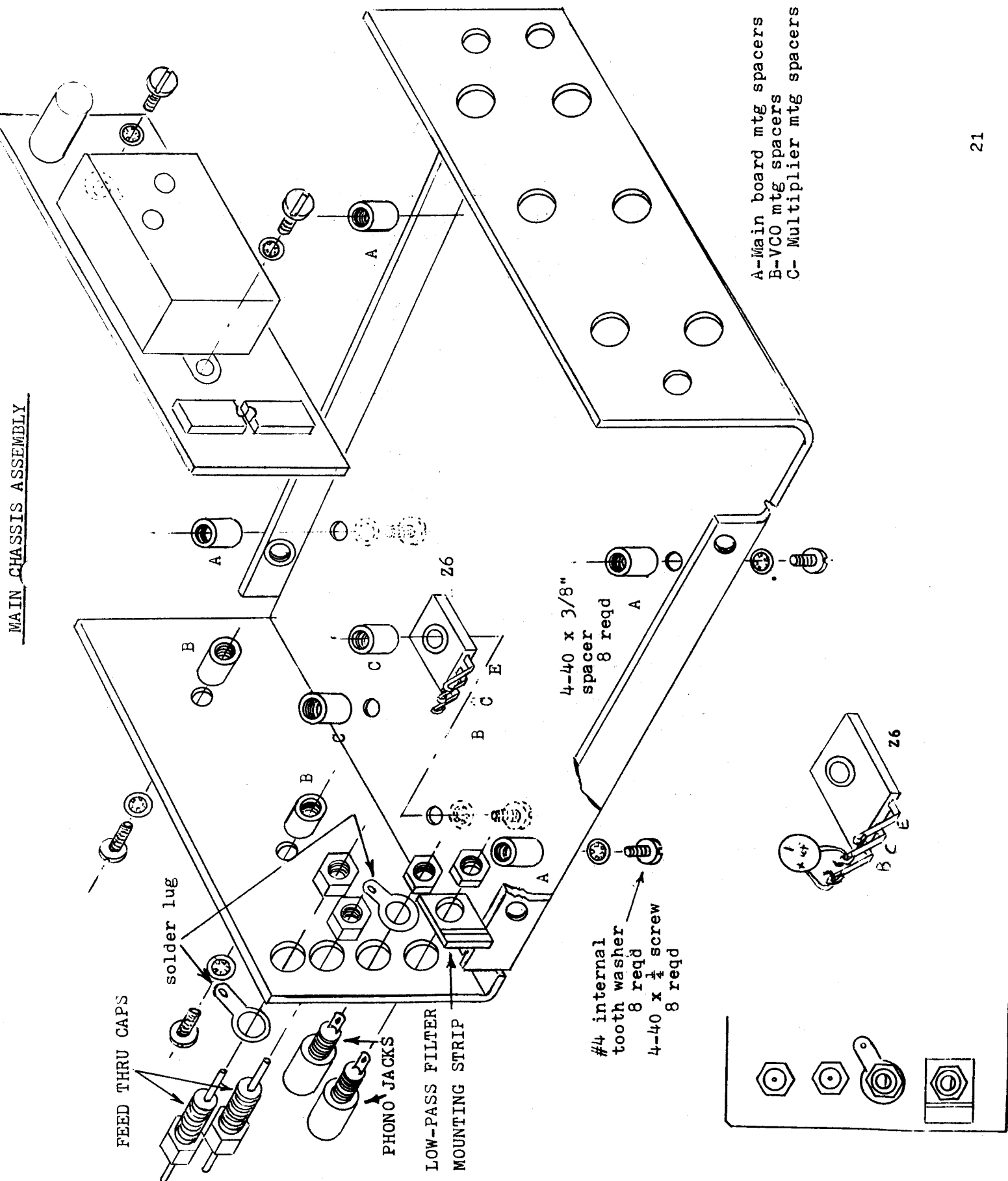

A-Main board mtg spacers
 B-VCO mtg spacers
 C-Multiplier mtg spacers

4-40 x 3/8"
 spacer
 8 reqd

#4 internal
 tooth washer
 8 reqd
 4-40 x 1/4
 screw
 8 reqd

CHANNELIZER WIRING

MAIN BOARD WIRING

The following instructions are for the ribbon cable used for the switch wiring.

FOR THE FOLLOWING STEPS REFER TO THE MAIN BOARD PICTORIAL.

On all measured leads strip 1/8" of insulation from each end unless otherwise noted. All wires are connected to the trace side of the board. Apply solder to each terminal and to the end of the connecting wire first, then make the connection by reheating the terminal while holding the pretinned wire against it. Don't apply heat to the terminals any longer than necessary and do not pull on the lead until after the joint has cooled completely.

- () 1. Separate the wires on one end of the 10-conductor ribbon cable to 1" from the end (use a sharp knife). Strip the ends 1/8" and tin the wire ends.
- () 2. Prepare the other end similarly except separate the leads for 2".
- () 3. Place the completed main board assembly, component side down in front of you with the pads numbered from 13 to 25 toward you. Tin the numbered pads.
- () 4. Starting with the end separated 1", connect the Black wire to #15.

COLOR	PAD #	✓
BLACK	15	
WHITE	16	
GRAY	13	
VIOLET	14	
BLUE	19	
GREEN	20	
YELLOW	17	
ORANGE	18	
RED	21	
BROWN	22	

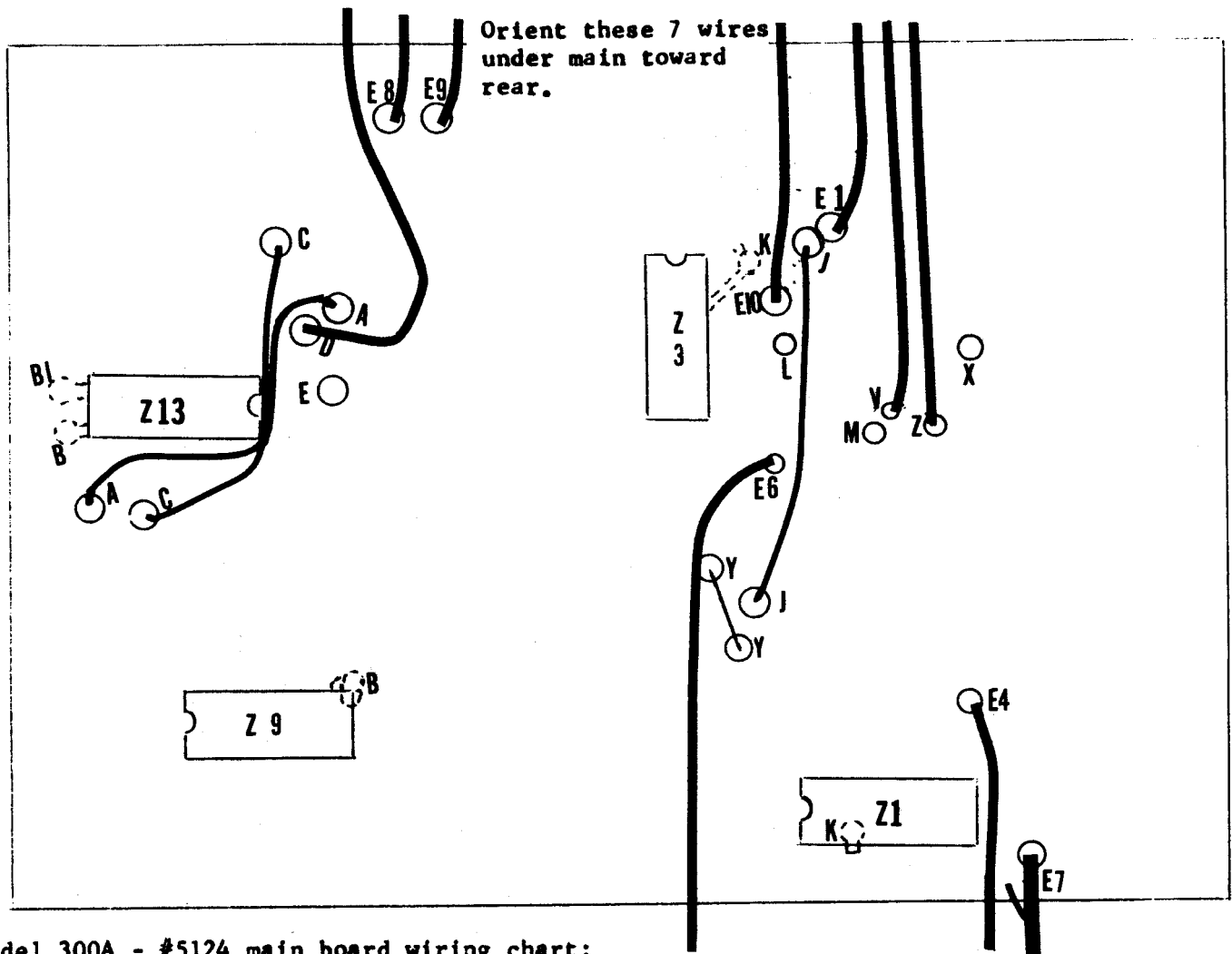

Model 300A - #5124 main board wiring chart:
Connect "from" end only at this time.

FROM	COLOR	LNG	TO	CHK
Main Board---E8	4	10"	Upper FT	
" " ---E4	0	9"	VCO--E4	
" " ---E6	1	9"	VCO--E6	
" " ---E1	2	8"	Z6--E	
" " ---D	3	8"	S6-right hand lug	
" " ---E7	coax	4"	VCO--E7	
" " ---V	9	8"	S4-upper lug	
" " ---Z	0	8"	S4-center lug	
Z6-B	2	5½"	VCO--E2	
Z6-E	3	4"	VCO--E3	

Cut wires to length.
Strip and tin 1/8".

Install the following jumpers on the main board as follows:

Strip and tin each end 1/8". Use White wire.

- () 1. 2" from "J" to "J" component side of board.
- () 2. 2" from "C" to "C" " " " "
- () 3. 2½" from "A" to "A" " " " "
- () 4. Resistor lead from "Y" to "Y".
- () 5. 2½" from "K" to "K" on trace side of board.
- () 6. 2" from "B" at Z9 to "B1" at Z13 - trace side.

MAIN CHASSIS WIRING:

- () 1. Position the main board vertically with the crystals up and the component side of the board towards the rear panel.
- () 2. Orient the ribbon cable, and the White and Brown wires from E9 and E10 towards the front panel.
- () 3. Tape the main board in this position with masking tape while wiring the switches.

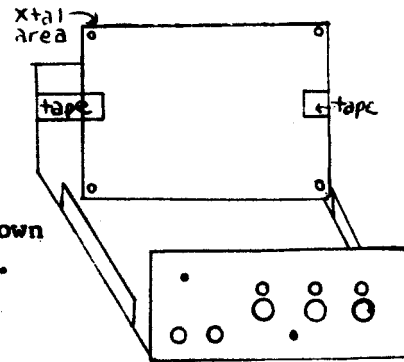

Refer to the switch assembly pictorial and the ribbon cable wiring chart on pages

- () 4. Using the pictorial and chart as a guide, connect the proper color of ribbon wire to the "E" number lug on the switches. (Separate the wires further as required when connecting the remaining wires).

FRONT PANEL WIRING:

FROM	COLOR	LNK	TO
WIRE FROM S1-CC	3	--	Z6-E
" " ILLUM. STRIP	9	--	Gnd, rear main brd.
" " " "	2	--	+12V feedthru
S6-ctr lug	9	1 1/2"	S2-CC
S4-bottom lug	9	1"	S5-ctr lug
Wire from 601 -- "L"	4	--	S5-upper lug
" " 601 -- "H"	0	--	S5-lower lug

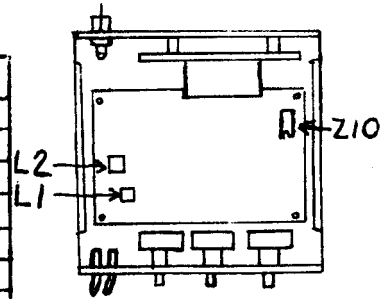

- () 6. Pull off the tape holding the main board in the vertical position and lower the board to its mounting position over the "A" spacers. Orient the remaining wiring toward the rear of the chassis. Fasten the board with 4-40x1/2" screws.

Take care not to crossthread the screws. If necessary loosen the spacers from the chassis side to line them up.

- () 7. Position the VCO board near the back of the chassis so that the two IC's are next to the chassis connectors.
- () 8. Connect the center conductor of the coax from E12 to the copper area on the filter mounting plate as shown. If you will be using the frequency multiplier on transmit, make this connection from the VCO according to the instructions with the frequency multiplier.
- () 9. The low pass filter provided with the GLB is in the 25 MHz range. Connect the parts as shown at the right using the luh choke and the two 47pf capacitors. If no filter is used or if a frequency multiplier is used on transmit, replace the choke with a short jumper.
- () 10. Connect the center conductor of the coax from E11 to the upper phono jack(receiver output). Connect the shield wire to the ground lug, keeping this lead as short as possible.
- () 11. Refer to the VCO pictorial and the 5124 main board wiring chart on page 23. Complete wiring from main board to VCO, Z6 and chassis connections.
- () 12. Mount the VCO board on the rear panel using 4-40x1/2" screws and #4 washers.

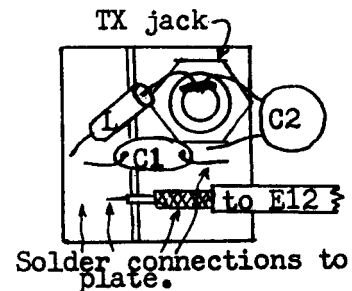

INITIAL CHECKOUT:

Connect three test wires to the rear of the Channelizer as follows:

- () A ground lead to the lug on the PTT (top) feedthru capacitor.
- () A B+ lead to the second from top feedthru.
- () A push to talk lead to the top feedthru.

A 12-volt DC power supply is needed for testing. It may be either a battery or a well filtered AC operated supply capable of delivering 450 ma. Voltage under load should be between 11 and 15 volts, and ripple should be less than $1\frac{1}{2}$ volts peak to peak.

This test is only to make sure that the supply voltages to the IC's are correct.

Use a voltmeter capable of indicating at least 6 volts. Connect the negative lead to ground and the positive lead to Z6 - E.

Turn the power supply on. The voltage reading should be between 4.75 and 5.25 volts. If too high, shut off power and check wiring.

Turn power off and remove the positive voltmeter lead. Turn the supply on again and probe the following points for limits indicated.

- () Z11 pin 14 (VCO) 4.75 to 5.25 volts.
- () Z1 pin 14 (MAIN) " " " :
- () Z3 pin 14 (MAIN) " " " :

Switch to a scale capable of indicating 12 volts DC. Probe the following points for the indicated voltages:

- () Bottom end of R2 (VCO) +12 volts
- () Top end of R2 (VCO) 10 to 11 volts
- () Left end of R44 (VCO) 9.5 to 10 volts

IF ANY OF THE ABOVE VOLTAGES ARE OUTSIDE OF THE INDICATED LIMITS, SHUT OFF THE SUPPLY AND RECHECK THE PARTS VALUES, POSITIONS AND WIRING IN THE APPROPRIATE PORTIONS OF THE CIRCUIT. IN PARTICULAR LOOK FOR SOLDER SPLASHES BETWEEN TRACES BENEATH THE BOARDS OR SHORTS BETWEEN IC PINS. Check the polarity of the electrolytic capacitors C49, C45, C36 and C31.

THIS COMPLETES THE INITIAL CHECKOUT. THE IC'S WILL NOW BE INSERTED.

Prepare the IC's for installation. Note that most of the IC's have the leads spread out at an angle (see right). For easy insertion press the leads against a hard flat surface (while holding the IC by the ends) until the leads are bent to a position perpendicular to the body. (see right)

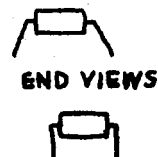

Make certain that the orientation marking on each IC corresponds to the positions shown on the layouts. The orientation mark could be a small dot or a notch in the end of the plastic package.

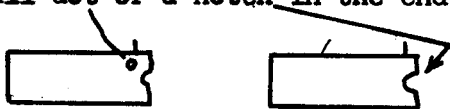

Insert the IC by setting it in place lightly over the pins. Make sure that all leads are lined up on the corresponding pin jacks. Insert it by applying pressure while gently rocking it end-to-end. Once properly started, press the IC all the way in.

Using the above steps, insert all of the IC's, as follows.

() Z1 (MC4044P)	() Z8 (74176)
() Z5 (74176)	() Z9 (")
() Z4 (")	() Z10 (7400)
() Z2 (")	() Z13 (7473)
() Z3 (74177)	() Z14 (7400)
() Z7 (74176)	() Z11 (74S00)
	() Z12 (74H73)

When the IC's are in place, repeat the initial voltage checks.

If the voltages are correct, procede to the alignment procedures outlined on page 27 after completing the following steps.

- () 1. With a pair of pliers, turn the rotary switches to the extreme counter-clockwise position.
- () 2. Install the knob on the MHZ switch with the "4" over the illumination hole.
- () 3. Install the remaining knobs with the "0" over the holes.
- () 4. Turn the chassis upside-down. With a ruler draw light pencil lines from front to rear of the chassis, 3/4" from each side. Than draw light lines parallel to the front and rear panels, 3/4" in. Remove the rubber feet from the backing one at a time and press them firmly into place at the four line intersections.

In the following steps coil adjustment is called for. Before attempting an adjustment, find a screwdriver that fits the slot in the slug properly. A jewelers or other small screwdriver is OK because the metal will not affect the tuning greatly. When making the adjustments don't drive the slug all the way to the bottom of the coil form. Proper position of the slug is above the center of the coil winding.

DO NOT RUN THE SLUG UP AND DOWN NEEDLESSLY.

Failure of the VCO adjustment to vary the indicated voltages means that the loop is not locking.
Check voltages and waveforms.

Alignment Procedure: (Note: GLB approval required on wired units in warranty.)

VCO alignment (low side injection)

1. Ground the PTT connection at rear panel.
2. SET FREQUENCY SWITCHES TO 147.99 MHz
3. Set both selector switches to the up position. Set the offset switch for simplex on "Low profile models".
4. Connect a DC voltmeter (VTVM or 20,000 ohms per volt) with the +lead to the E4 side of R6 (main board) and the -lead to ground.
5. Apply power.
6. There should be a reading between 1.3 and 5 volts. If outside these limits, there is trouble with the unit.
7. Tune the slug in L3 for a reading of 1.75 to 2.0 volts.
8. Disconnect the PTT ground.
9. Tune C37 for a reading of 1.75 to 2.0 volts.
10. Ground the PTT terminal again.
11. If the voltage changes outside of the above limits, readjust L3 and repeat steps 8,9 and 10.

Master Oscillator Frequency Adjustment:

1. Select from the list below a test point having a frequency within the frequency capability of your counter.

	2 Meters	
25.000 MHz		top of R18
2.500 MHz		Z5 pin 12
.250 MHz		Z4 pin 12

2. Connect the counter to the desired test point.
3. Apply power.
4. Adjust L1 carefully for the indicated frequency for that test point.
5. Shut off power and disconnect frequency counter.

5. Offset Crystal Oscillator Frequency Adjustment.

1. This adjustment should not be made until the master oscillator is accurately adjusted as in procedure 4 or 5.
2. Do not attempt to connect a frequency counter to the offset oscillator directly, because the probe capacitance will disturb the circuit.
3. Connect a frequency counter to the receiver output jack.
4. Calculate the frequency needed for your receiver to receive a selected frequency.
5. Adjust the slug in L2 for the frequency calculated in step 4.

If a frequency counter isn't available:

3. With the Channelizer mated to your transceiver, switch to a channel having a signal known to be on frequency accurately.
4. Connect a suitable meter to the discriminator of the receiver.
5. Adjust the slug in L2 for a zero discriminator reading.

TROUBLE SHOOTING INFORMATION

Since about 90% of the circuitry in the Channelizer is involved in a phase-locked loop, the most common problem is an out-of-lock condition. An out-of-lock condition occurs when the VCO is not being properly controlled by the remaining circuits. In this condition the VCO behaves as an unstable self excited oscillator and the test point voltage at R6 is either at +5 or +1.3 volts, with the VCO adjustment L3 having no effect.

If the voltage at R6 is +5 and it wont tune any lower.....

The trouble is in the IF path:
Check Q17, Q5, Q6, Z10 and the remaining IC's thru to Z1 for parts placement, shorts, bridges, unsoldered joints, etc. See waveforms.

If the voltage at R6 is +1.3 and it wont tune any higher.....

The trouble is in the crystal oscillator or divider circuits:
Check Q16, Q15, Z5, Z4, Z3, Z2 up to Z1 pin 3. Check these areas for the trouble. Check frequencies and waveforms.

If the voltage jumps abruptly when tuned from 1.3 to 5V or vice-versa.....

Make sure a DC path ezists from the collector of Q3 (R6) thru the wire to E4 on the VCO board, thru R41, R42, R43 to D6. Make sure there are no grounds at any point along this line. When checked with a DVM or VTVM there should be negligible DC drop along this path.

If a "lock" is indicated on transmit (VCO tunes properly) but not on receive:

Check the oscillator circuit Q13.

IF THE UNIT LOCKS NORMALLY BUT THERE IS NO OUTPUT.....

Make sure you have the output programmed properly.

Check the output circuits Z11, Z12.

Check the coax cables, to the output jacks for breaks or shorts.

Are they connected to the right places?

Be sure your method of measuring output is valid. A diode detector to a DC voltmeter, an RF power indicator or a fast oscilloscope are good. A frequency counter or the rig you are driving are unreliable indicators.

IF EVERYTHING SEEMS TO BE WORKING BUT YOU HAVE SPURIOUS OUTPUT OR SPURIOUS RESPONSES.....

The situation could be normal if you are hearing nearby stations on the wrong frequencies weakly and the responce is crystal-stable. Our specified -60 db minimum spurious rejection meets EIA standards for commercial equipment but may not reject extremely strong nearby stations or vice-versa.

If the "spurs" are unstable (even very slighty) it most likely indicates that you have an unstable interface. Since we depend upon information from our customers concerning the interfacing of various rigs, the interface may or may not work properly for you. In many cases the same type of equipment behaves differently from unit to unit.

Also, don't overlook the possibilty that the other station may be having problems, too.

If the Channelizer does not operate, make the following checks.

Voltages taken with Simpson 260:
Waveforms with Tektronix 465:

1. Check voltage at both ends of L5 (47uh) on VCO board. 4.4 to 5.2V.
2. " " " " " " R38 (1K) " " " 4.4 to 5.2V.
3. Voltage at E23-end of R14 near E10. TX-4.0V. RX-.9V.
4. Voltage at E24-end of R58 near Q14. TX-.1V. RX- 5.0V.
5. Check waveform at Z1-pin-3 (4044)
square wave abt 4V p-p. ----- 2 Meter-frequency 1.666 KHz,
5. Check waveform at Z1-pin-3 (4044)
Square wave abt 4.0V p-p.
2 Mtr. -frequency - 1.666 KHz.
6. Check mixer (Q5) waveforms.
7. Check waveform Z1-pin-1. --
8. Check transmit and receive outputs.

1 volt per division
All waveforms

Z1 Pin 1

Dial 147.99

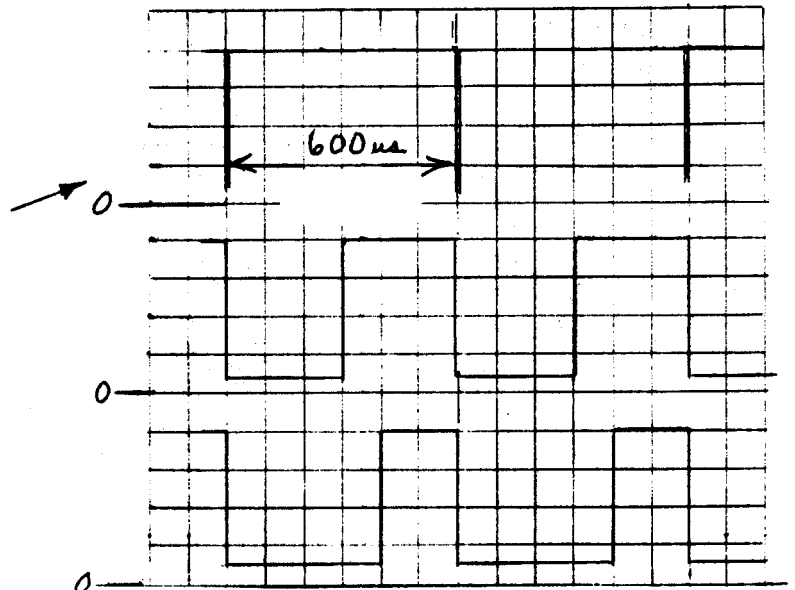

NOTE: When locked, the period is always
600 us at Z1, pin 1, at 2 Meters.

Only the duty cycle changes
with dial setting.

Make the frequency checks on page 27. Check the following:

2 Meters - Z1-pin 1. - 1.667 KHz.
" " - Z1-pin 3. - 1.667 KHz.

TROUBLE-SHOOTING HELP

If you wish to call or write us concerning a problem, send complete information regarding the symptoms. Go over the checks on pages 29&30. MOST IMPORTANT---We will need the serial number of the unit. This is engraved on the bottom of the chassis and is the same as your order number.

REF ÷ Input
Col Q5

F= 25.000 - 2-Meters

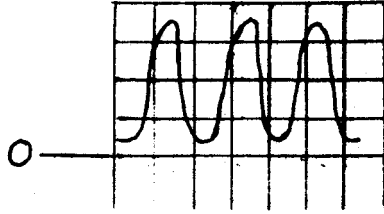

MIXER GATE #1

Top of L6

F= same as above

F in RX= X2

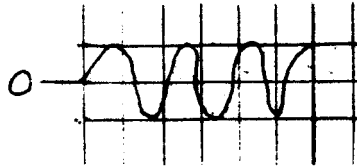

MIXER GATE #2

F= VCO Freq.

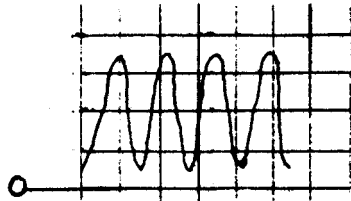

NOTE:

VCO Freq. = 24.665 MHz at
147.99 dial TX.

MIXER DRAIN

F= 335 KHz at

147.99 dial

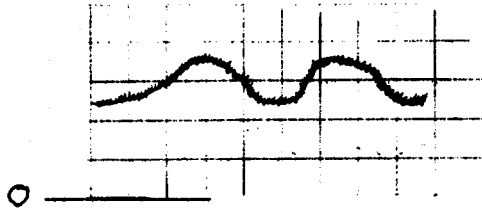

Z10 pin 12 & 13

F= 335 KHz at

147.99 dial

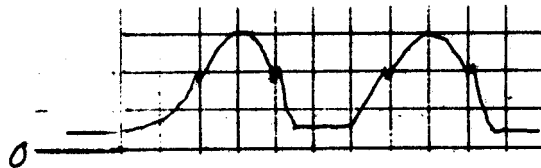

E7 (main board)

F= VCO Freq.

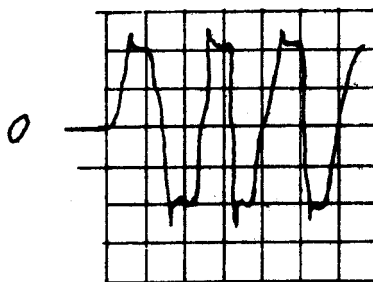

FACTORY SERVICE

All replacements or repairs require prepaid shipment to GLB Electronics. In-warranty repairs to factory-built units will be made free of charge, providing the terms of the warranty are not violated. In-warranty repairs to kits will be made free of charge when in the opinion of GLB Electronics the fault lies with the design or is due to defective parts supplied by GLB and where such defect interferes with the normal intended use and operation of the equipment. In other cases a charge will be made for labor and any customer-damaged parts. If the service costs are a substantial portion of the original cost of such equipment, the customer will be notified before such service is performed.

RETURNS:

It is advisable to keep the original shipping carton in case shipment to GLB is necessary. Make sure that the unit is well padded and protected against damage in shipment and insure it. Include a note describing the difficulty. In the case of Channelizers include the transceiver type the unit is being used with. Make sure all parts are included. Ship prepaid to:

**GLB ELECTRONICS
SALES DIVISION
1952 CLINTON ST.
BUFFALO, N.Y. 14206**

Tel. 716-824-7936

In order to avoid unnecessary delay or charges, be sure to complete all steps in the assembly instructions before returning for service. Include instructions describing the services you wish to have performed and the type of rig the unit is for.

Return shipments will be sent collect.

GLB ELECTRONICS warrants that for a period of 90 days from the date of shipment, all GLB-supplied parts shall be free from defects in materials or workmanship. Defective parts or assemblies shall be replaced or repaired upon the return of such parts or assemblies without further damage to GLB ELECTRONICS. This warranty is and shall be in lieu of all other warranties, whether expressed or implied and in no case will GLB ELECTRONICS be liable for any anticipated profits, consequential damages, loss of time, or other losses incurred by the purchaser in connection with the purchase or operation of GLB products or components thereof. Parts damaged in handling or assembly by the purchaser shall not be replaced.

Factory wired units are warranted for a period of 180 days from date of shipment. The unit must be returned to the factory prepaid with a note describing difficulty. Our liability under warranty is limited to repair, adjustment or replacement of units proven to be defective. No other warranty is expressed or implied. Units modified or obviously misused will not be covered by the warranty.

SWITCH WIRING

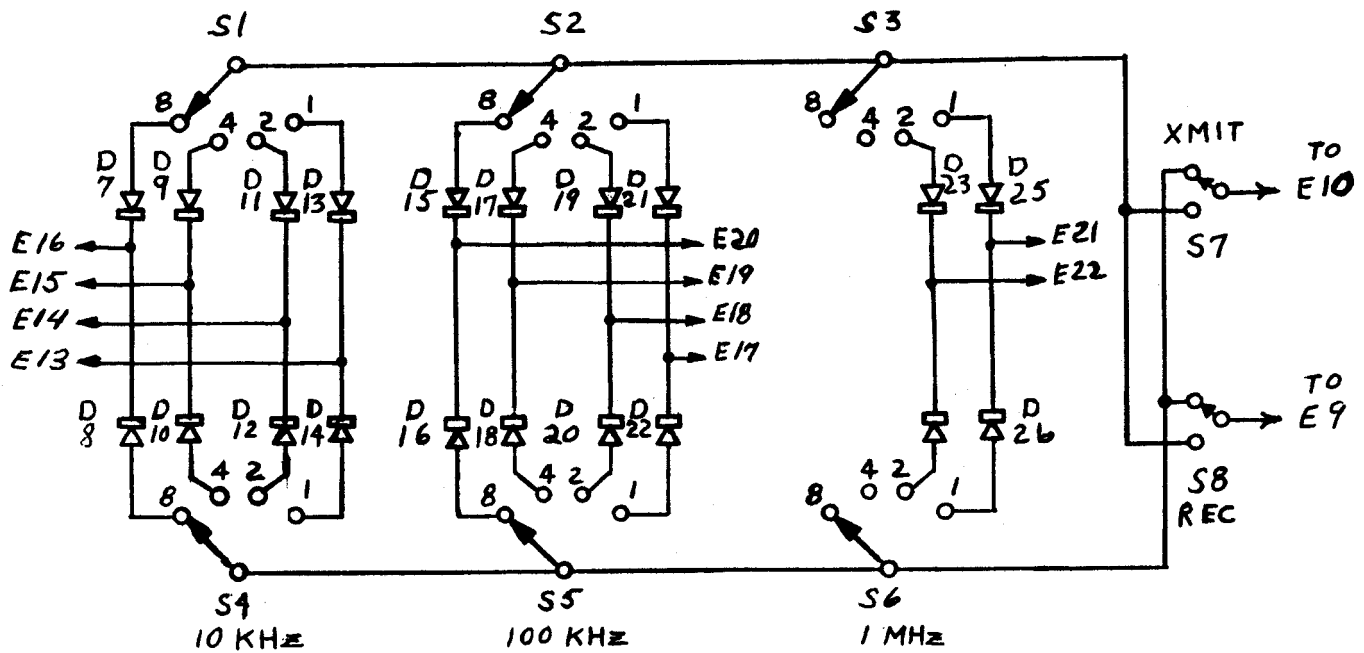

TYPICAL GLB CHANNELIZER
BLOCK DIAGRAM

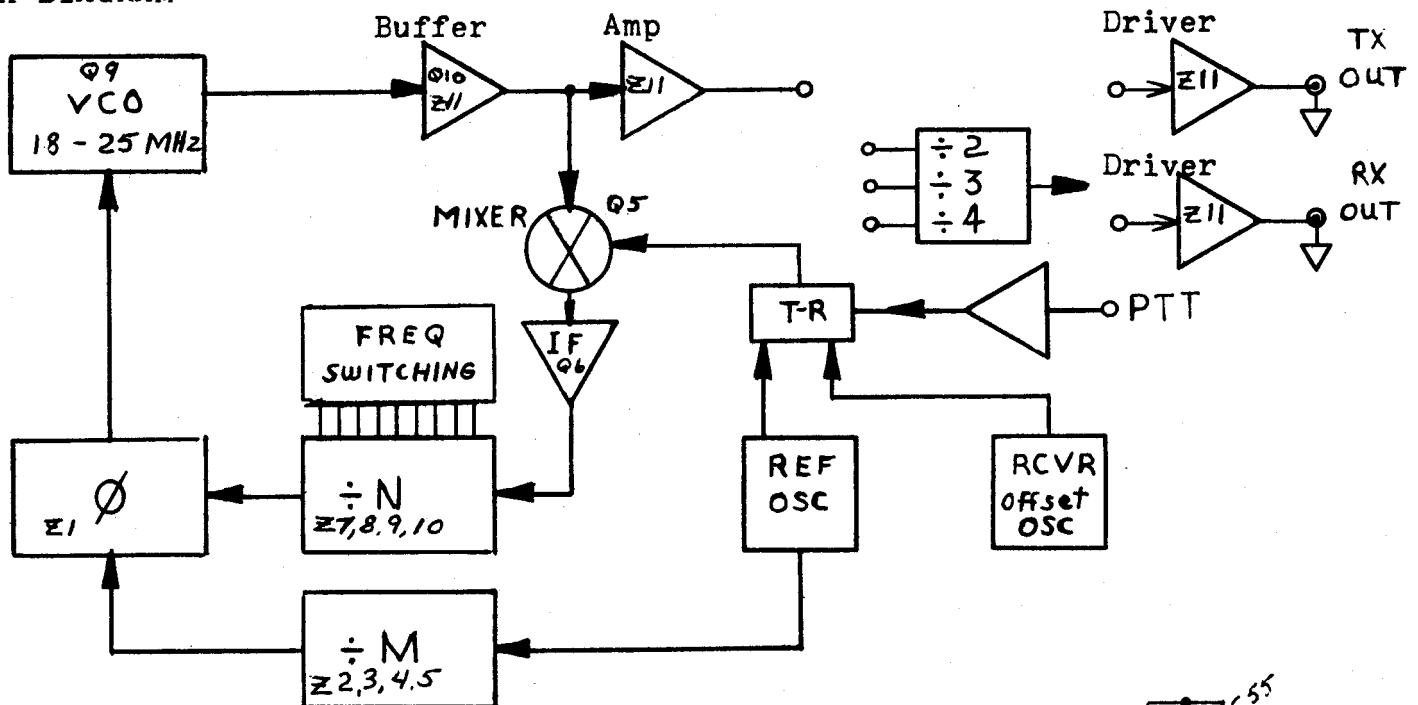

Divide by M is programmable for 144, 220 & 450 MHz models.)

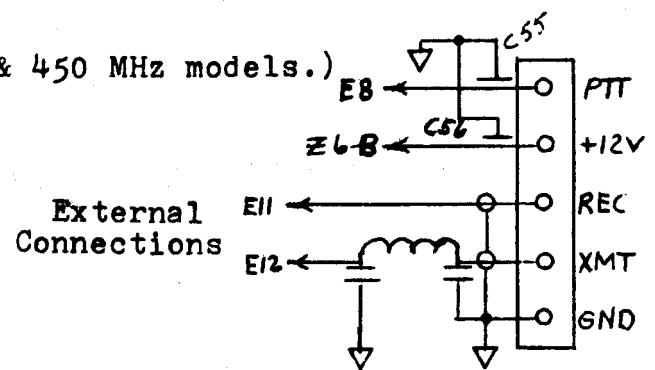

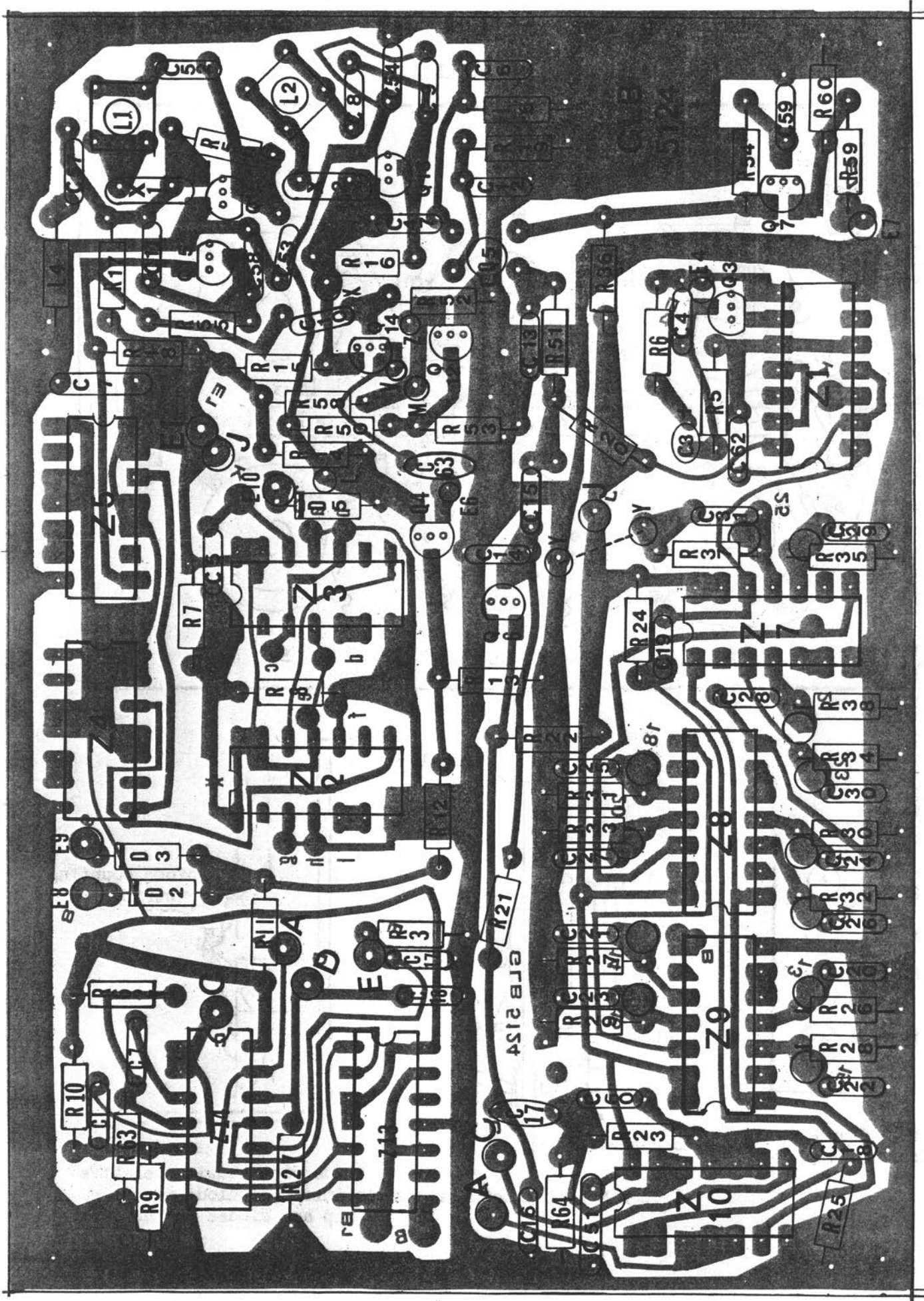

GLB ELECTRONICS #5124 Main Board Layout

GLB ELECTRONICS
MODEL 300A CHANNELIZER

White-6" to ground

Red-8½" to +12 feedthru

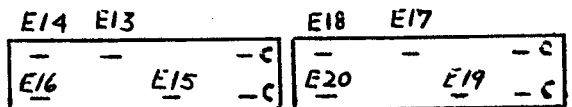
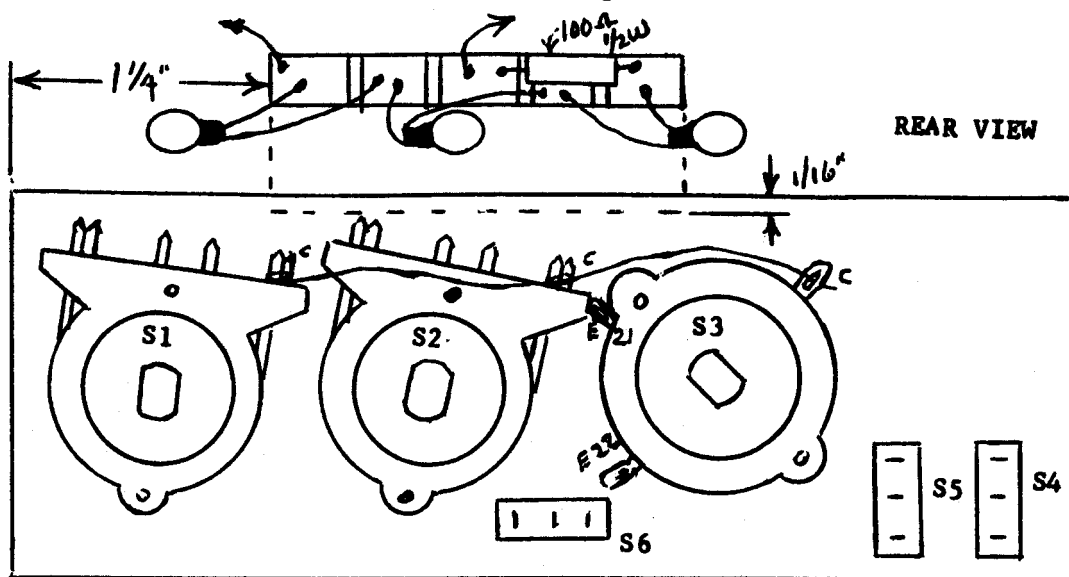

S1 S2

TOP VIEW

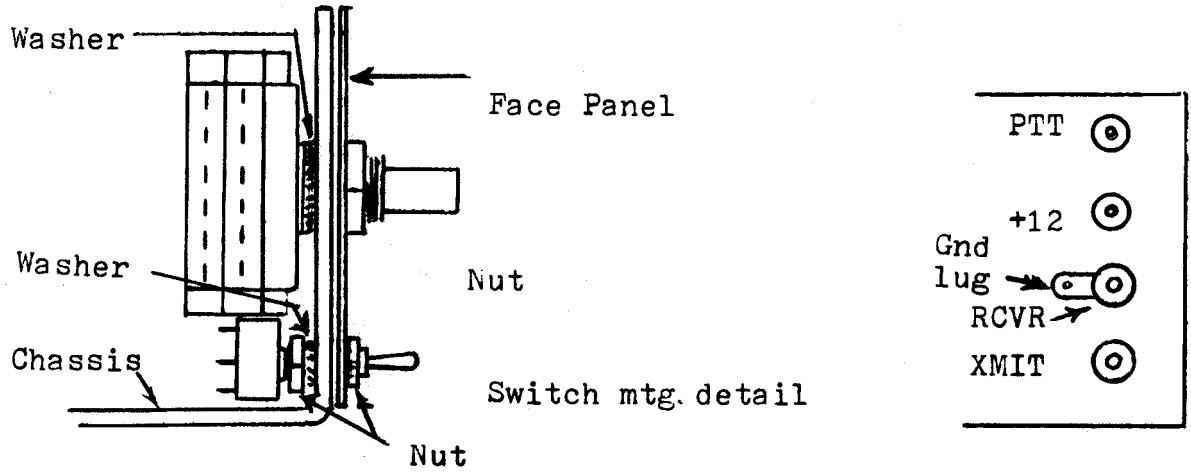

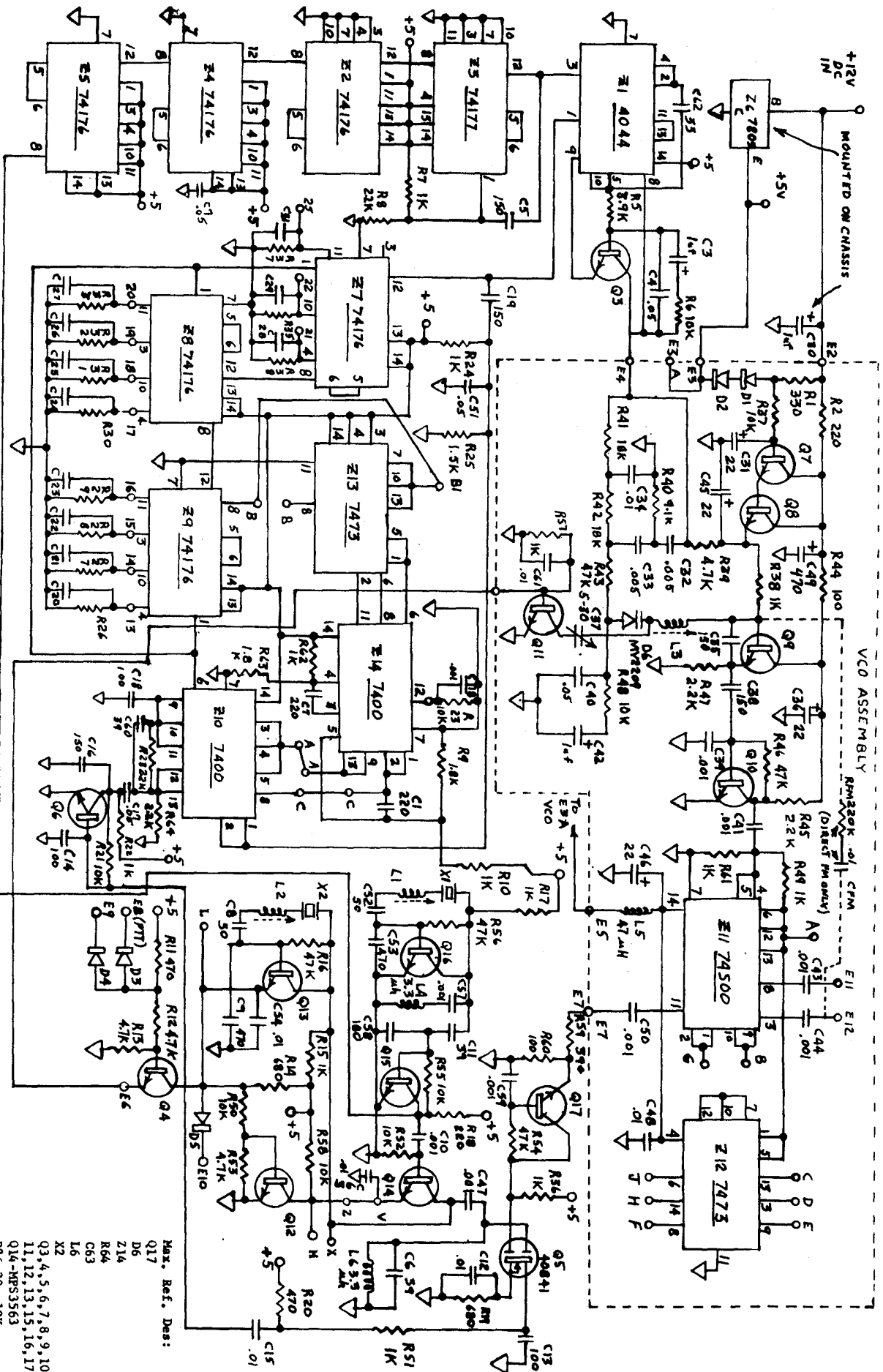

GIB MODEL 4008 CHANNELIZER
 5 kHz steps -- 144 to 147.995
 1/16/78

Capacitor values in pF unless value less than 1
 or marked with polarity. All others in uF.
 Resistors in ohms.

Max. Ref. Des:	Value
Q17	40041
D6	470
Z14	74176
Q14	74176
R26-38	10K
C20-31	100
D1-5	1N914 or 1N4148

All 400B instructions for assembly of the main and VCO boards apply to the Mod. 300.

CHANGE PARTS LIST AS FOLLOWS:

DIODES:

Small signal 5 ()

SWITCHES:

4 position rotary* 1 (✓)

BCD 10 position rotary 2 (✓)

* With Band Extender kit, 3 BCD 10 position rotary switches are furnished.

WIRE:

BROWN 36" ()

RED 40" ()

YELLOW 36" ()

WHITE 40" ()

GRAY *as strip* 30" ()

ORANGE 40" ()

RIBBON WIRE 8" ()

MISCELLANEOUS:

Knobs 3 (✓)

Q2 mtg. kit 1 ()

miniature lamps 3 (✓)

Lamp mtg. strip 1 (✓)

DELETE:

Heat sink strip

Terminal strip

HARDWARE:

3/8" nuts 3 (✓)

3/8" washers 3 (✓)

Front panel 1 (✓)

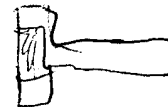

Follow the 400B Main and VCO assembly instructions to end of page 7. Page 11, steps 49 to 53.

If your transceiver requires the frequency multiplier, complete its assembly and installation before proceeding with the main chassis wiring.

Install silk screened front panel and switches. If you are installing the preset and/or the 5 KHz options, the holes will have to be drilled for these options before the front panel is installed. See panel detail. Drill holes in panel, install panel and switches. Transfer drill option holes thru chassis after installation.

Install all chassis hardware Mount the power transistor, Q2 - 2N5296 as shown.

ILLUMINATION:

Solder the 3 lamps, +12 volt and ground wire to the illumination strip as shown. Remove the backing from the strip and position as shown.

Press into place. Route the wires as follows: +12 volt wire to +12 volt feedthru, solder. Ground wire to rear of main board ground trace, solder.

Connect the BCD switch commons using orange wire. Follow wire dimensions on sketch. Route the 6 1/4" orange wire to Q2 - Emitter, and solder. Proceed with main board and 600 KHz wiring.

Refer to 400B instructions, Page 13, step 71 to page 14, step 91 for coax wiring and hardware installation.

Complete main board and 600 KHz wiring. Complete page 15 to page 18 of 400B instructions.

WIRING INSTRUCTIONS FOR GLB MODEL 300.

All wire color designations are standard color code numbers:

1 - Brown. 2 - Red. 3 - Orange, etc.

Follow the Main Board wiring layout and wiring chart. Cut, strip and tin each wire as indicated in the chart, and solder each wire to the main board only.

All wires are stripped and tinned $\frac{1}{8}$ ", with the exception of the wires connecting to S1, S2 & S3. All wires connecting to these switches should be stripped and tinned $\frac{1}{2}$ $\frac{1}{4}$ ".

As each wire is soldered into the main board, check off in the column provided in the chart.

After all wires are soldered to the main board, route these wires as shown on wiring layout and tie with plastic ties as shown.

Set main board aside and wire 600 KHz offset board.

Complete chassis wiring. Follow charts and wiring layout. After each wire is soldered to its final destination, check off in column marked "Dest".

Bring the 4 wire ribbon from E13,14,15,&16 under the main board to S1. E17,21 &22 to S3. Solder to the proper points on S1,2,3.

Bring the 3 wire ribbon from E18,19 & 20 over to the 600 KHz board and solder to E5,6 &7 as shown.

Route the wires from E1,2,3 & BQ2 toward the rear of the board and solder to the proper points as shown.

Route the wires from E4,5,6 &8 toward the rear of the board and solder to the proper points as shown.

On the 600 KHz offset board, route the wires from E1,2,3,4 &8 toward the front of the board and solder to the proper points as shown.

Bring the 2 wires from the top of R14 & R58 toward the front of the board and solder to S4 as shown.

Check all wiring connections. Mount boards in chassis and proceed with final assembly and test.

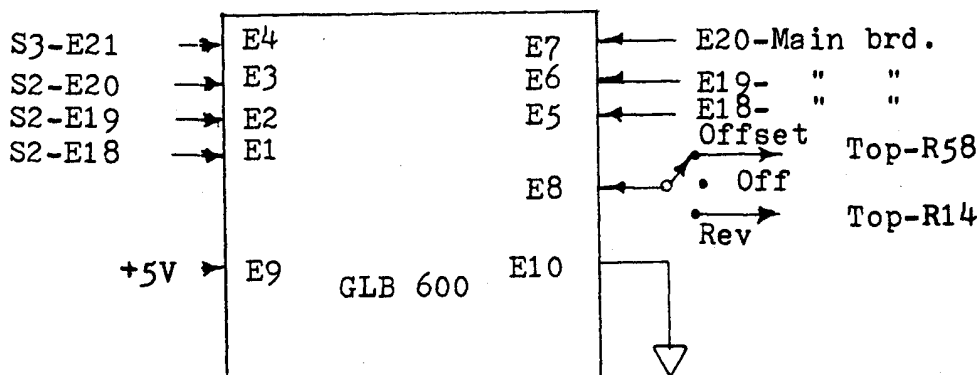

E#	CLR	LNG	DEST	✓	E#	CLR	LNG	DEST	✓
E1	2	10½"	+12-FT	✓	E15	RIB 2	8"	S1-E15	✓
E2	4	6½"	E2-VCO	✓	E13	" 1	"	S1-E13	✓
E3	3	6½"	E3-VCO	✓	E16	" 3	"	S1-E16	✓
Q2-B	8	7"	Q2-B	✓	E14	" 4	"	S1-E14	✓
Q2-C	9	7"	Q2-C	✓	E20	" 8	"6"	E7-600	✓
Q2-E	1	7"	Q2-E	✓	E19	" 9		E6-600	✓
E4	4	9"	E4-VCO	✓	E18	" 0		E5-600	✓
E5	2	6"	E5-VCO	✓	E17	" 5		S2-E17	✓ X
E6	1	7½"	E6-VCO	✓	E21	" 6		S3-E21	✓ X
E8	9	6½"	PTT-FT	✓	E22	" 7		S3-E22	✓ X
R14	3	7"	Top-S4	✓	E7	coax	5"	E7-VCO	✓ X
R58	9	7"	Bot-S4	✓					

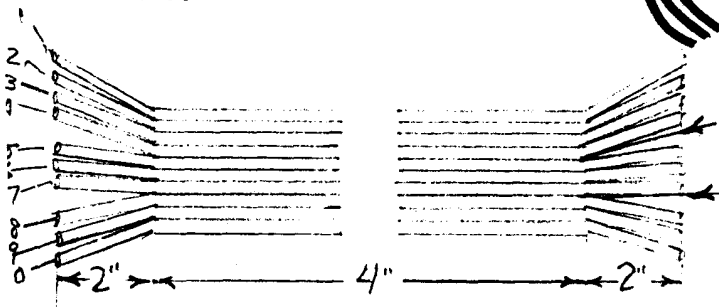
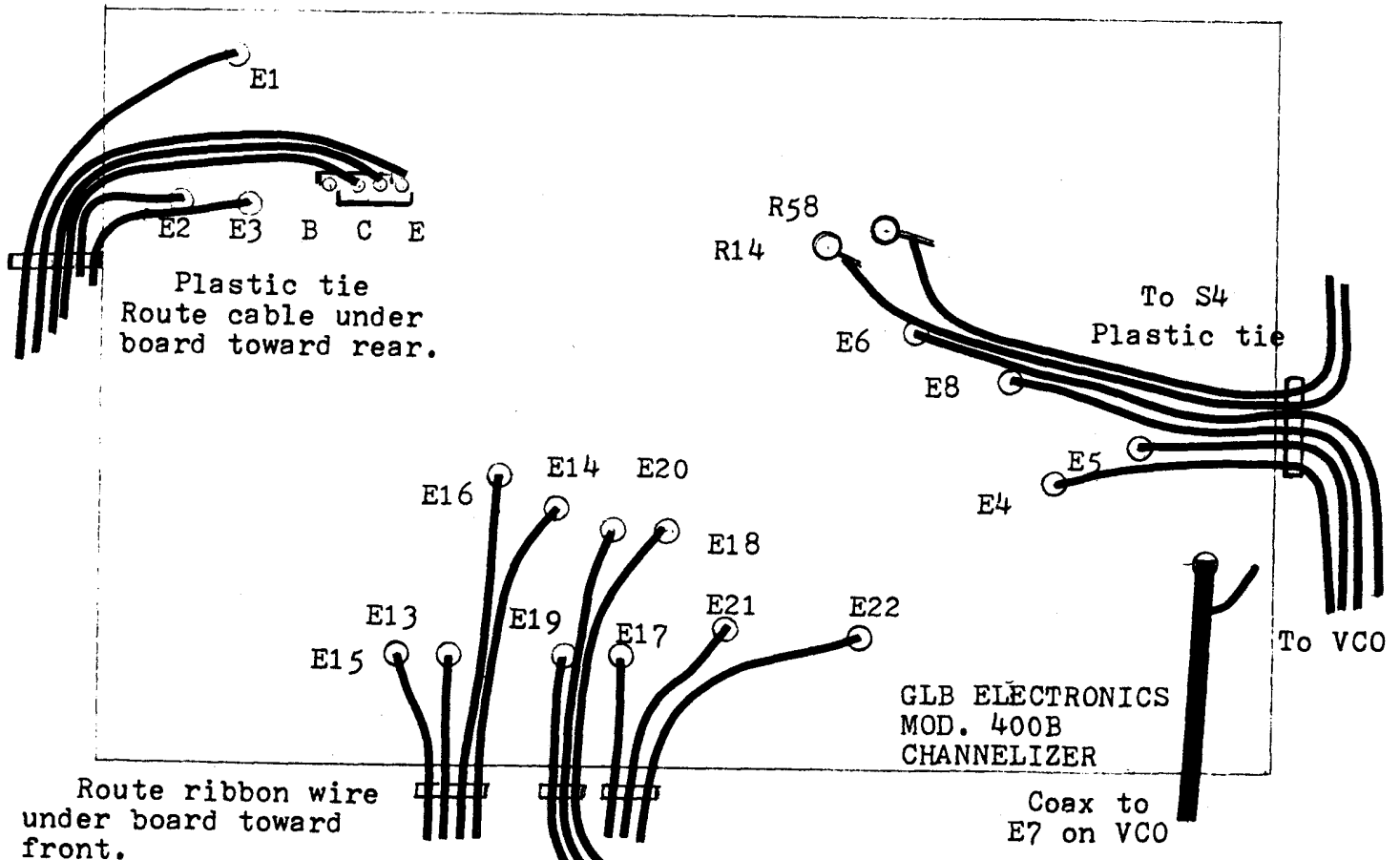

Cut ribbon at points shown. Use a sharp pointed Xacto knife. Separate into 1 - 4 wire ribbon and 2 - 3 wire ribbons.

GLB MODEL 300 CHANNELIZER

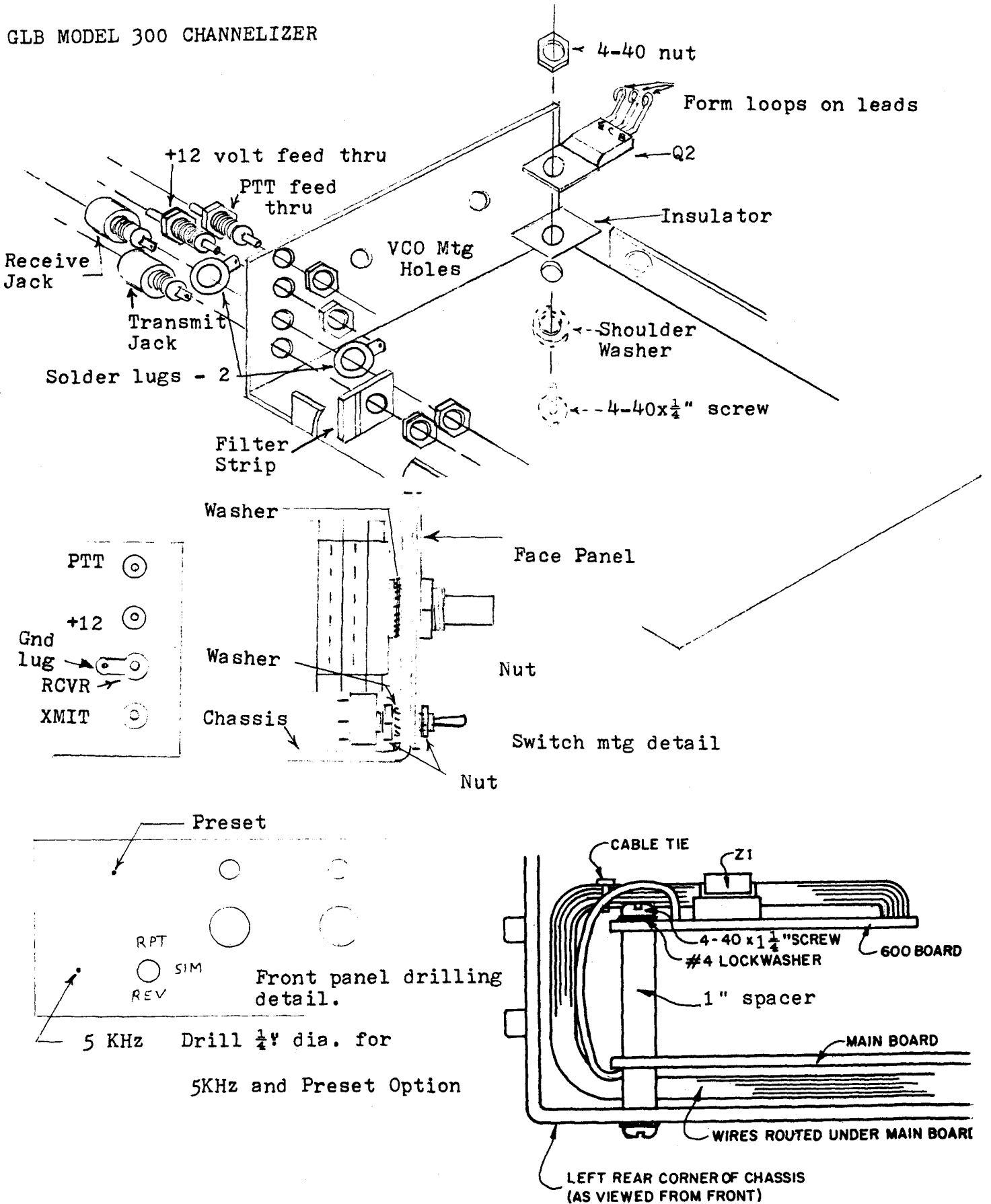

*Xamps are placed above switches
NOT in holes*

GLB Model 300

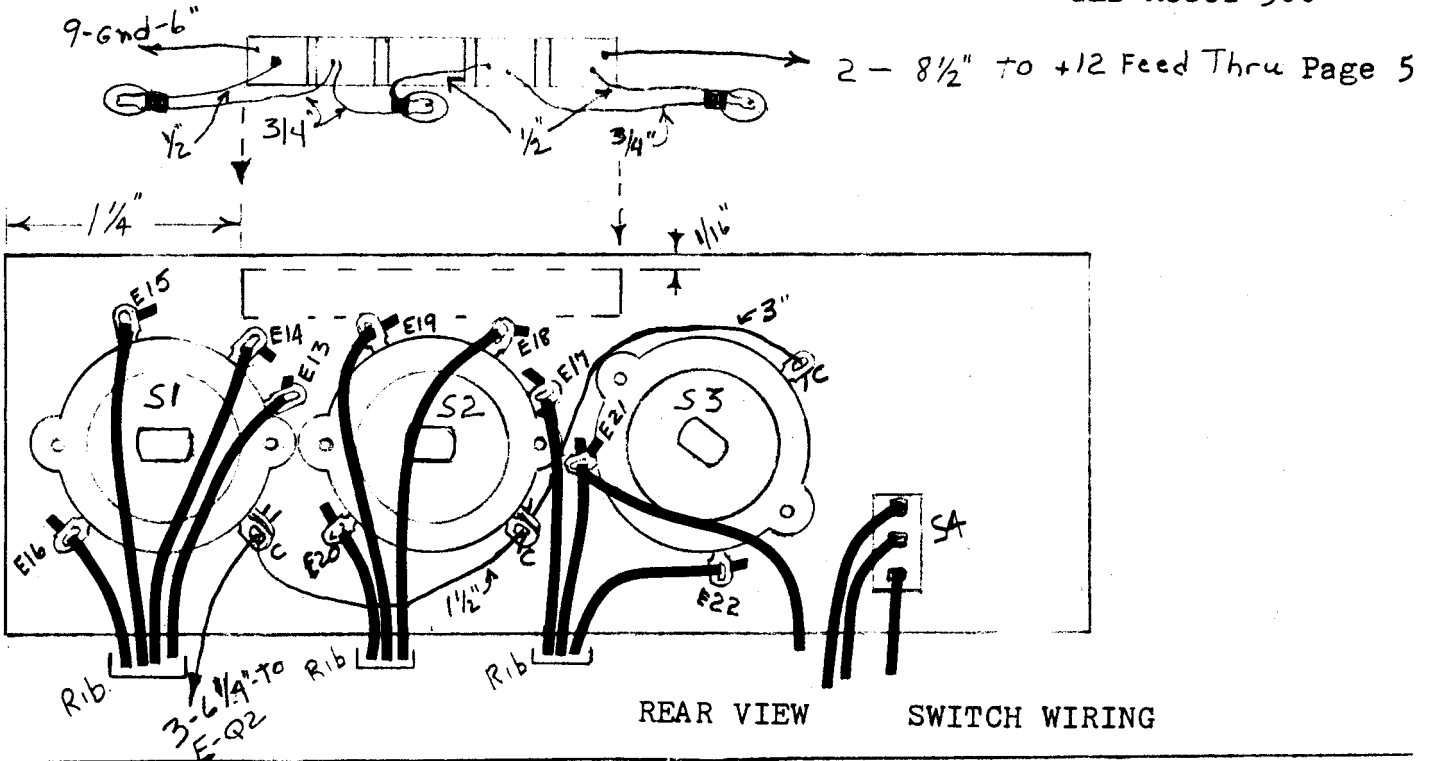

5 KHz modification for Mod. 300

When the 5KHz kit is installed on the Mod.300, 1 spade lug is used for mounting.

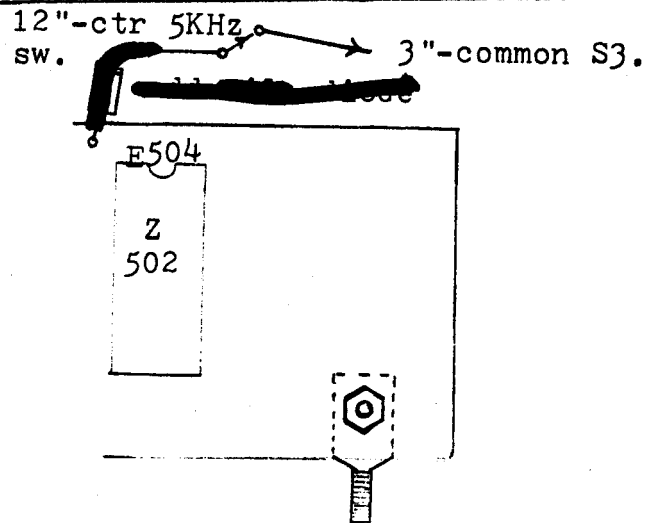

Modifications for installing the Preset kit on Model 300 Channelizer

Remove the orange wire from the panel switch common, going to E-Q2. Run a 12" lng. of wire from E-Q2 to both common lugs of the preset switch. Connect a 3" lng. of wire from the panel switch common connection to the #1 position lug of the preset switch. Xmit deck.

A diode terminal strip and 10 diodes must be added. Keep terminal strip as close to the switches as possible.

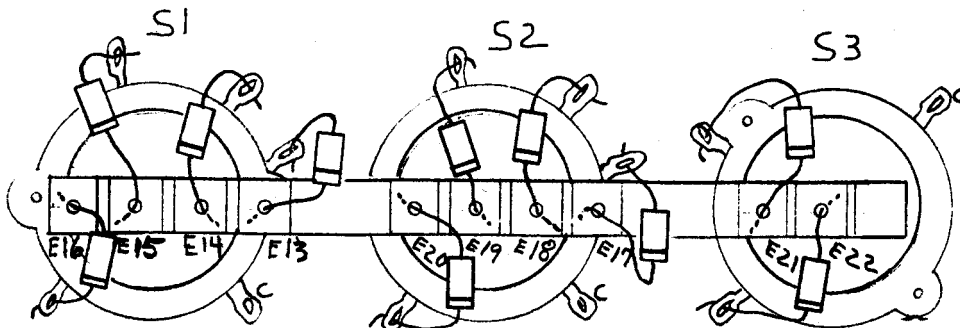

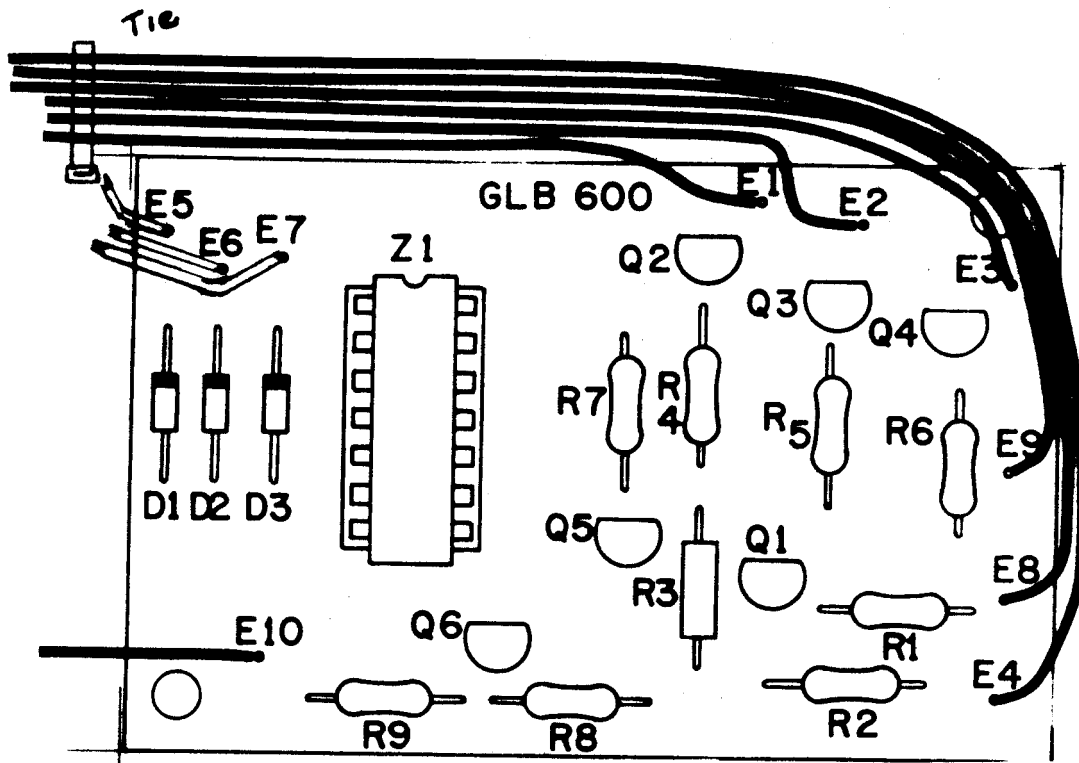

Wiring chart - 600 KHz board

E#	Clr	Lng	✓	Dest	✓
1	2	10"		S2-E18	
2	4	10"		S2-E19	
3	9	10½"		S2-E20	
4	1	11½"		S3-E21	
8	8	9"		S4-Ctr	
9	3	9"		E-Q2	
10	8	5"		Gnd	

600 KHZ OFFSET
FOR 400B

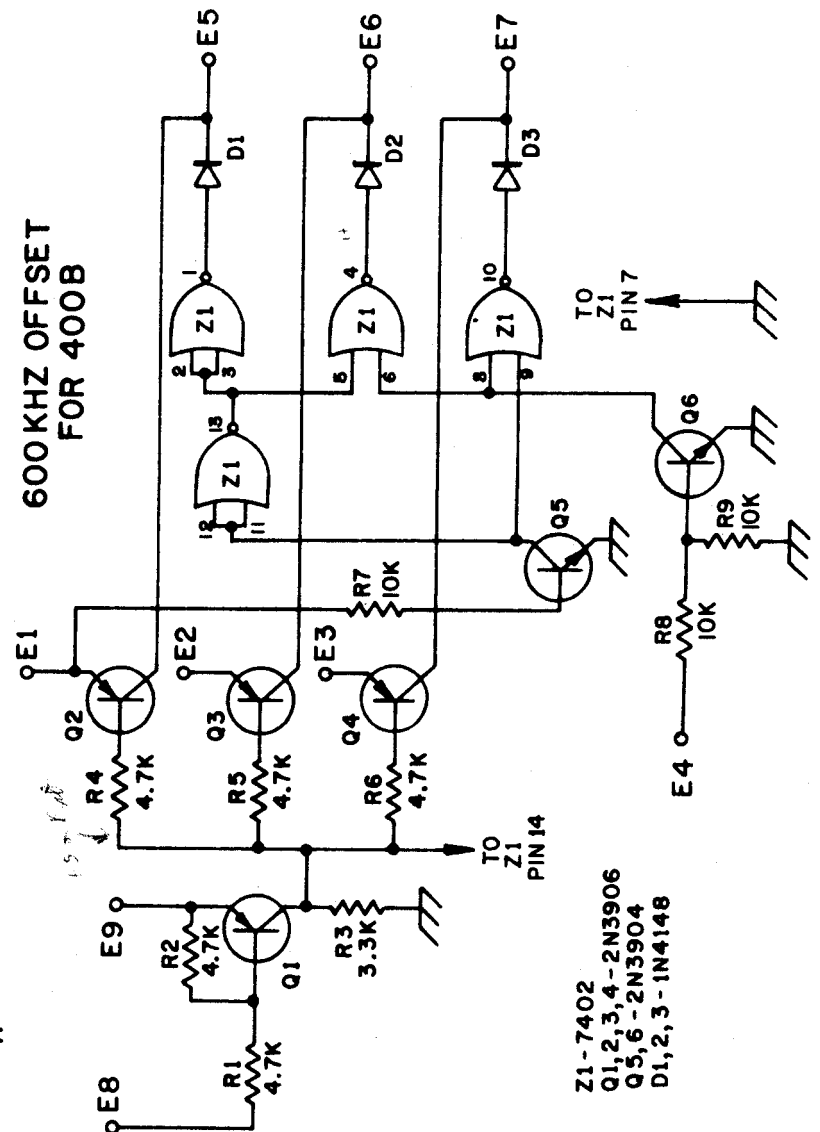

- Z1-7402
- Q1,2,3,4-2N3906
- Q5,6-2N3904
- D1,2,3-1N4148

