Repeater Builder
 STM32-DUM-MTR2K U3
 (C) 2020 - N3XCC Rev.

SBC SERIAL
 5v Tx Rx GND

I/O PROCESSOR
 I/O SERIAL EN.

UART LEVEL SHIFT

Install to Emulate Aux I/O Card

ANALOG HANDSHAKE ENABLE
 HA08EDA

LSP2 LSP3 LSP1
 C30 4.7uF C29 4.7uF C28 100nF C27 100nF

GND +U
 EXT PWR

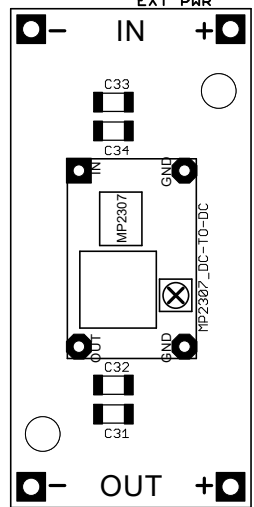

DIN 41612 - C

N0MJS
 N3XCC

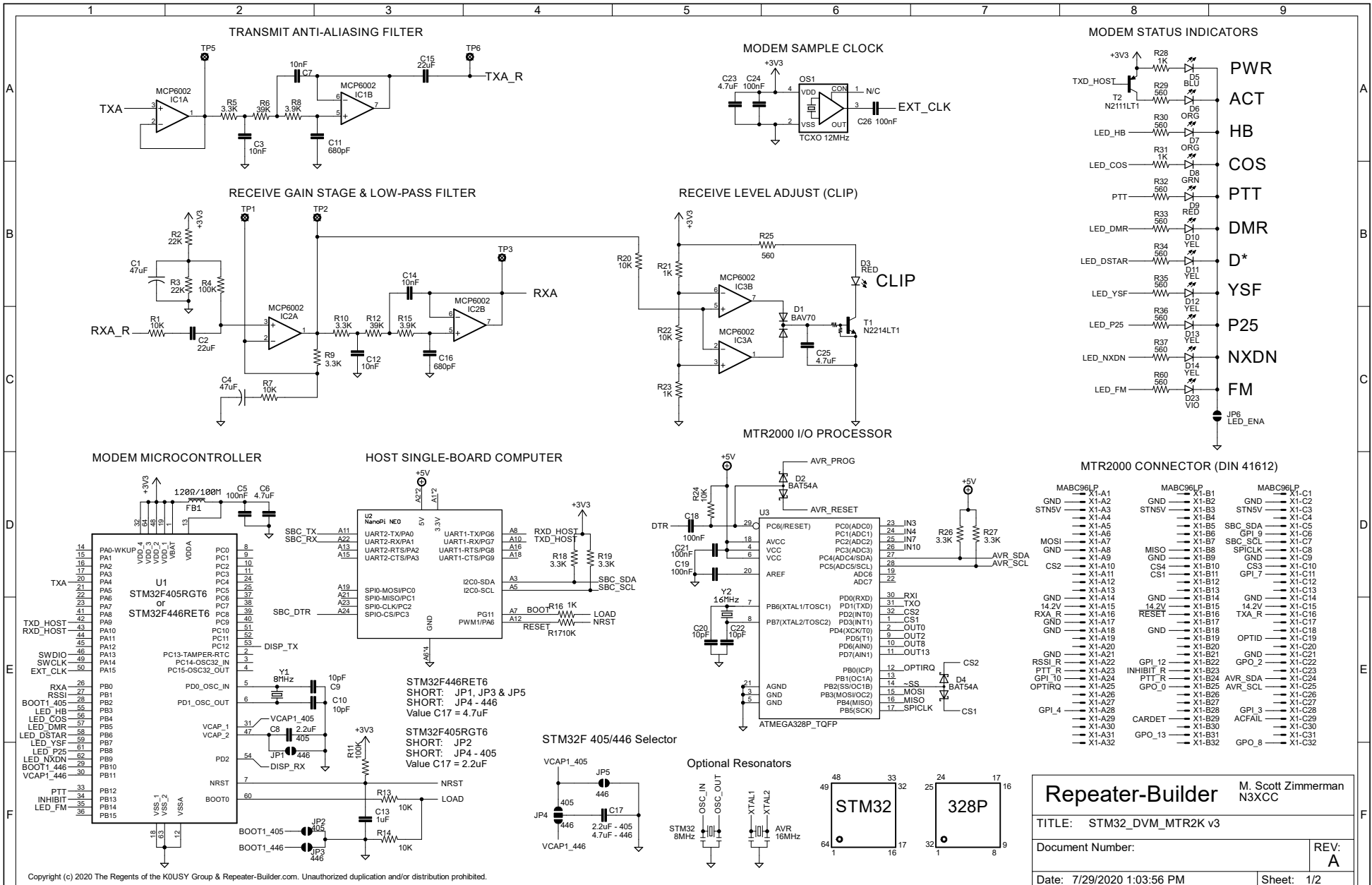

Copyright (c) 2020 The Regents of the K0USY Group & Repeater-Builder.com. Unauthorized duplication and/or distribution prohibited.

Repeater-Builder M. Scott Zimmerman
N3XCC

TITLE: STM32_DVM_MTR2K v3

Document Number: _____ REV: A

Date: 7/29/2020 1:03:56 PM Sheet: 1/2

POWER SUPPLIES/FEEDS

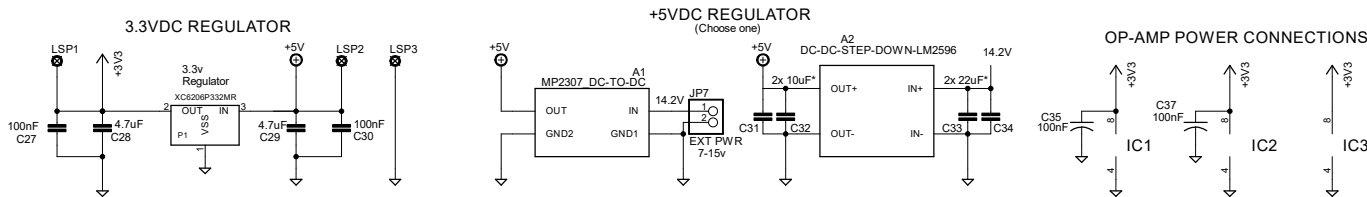

PIN HEADERS

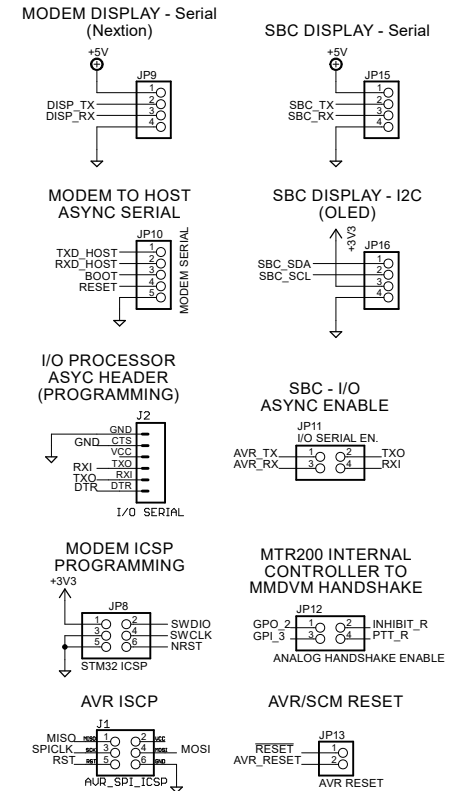

DIGITAL I/O BUFFERS

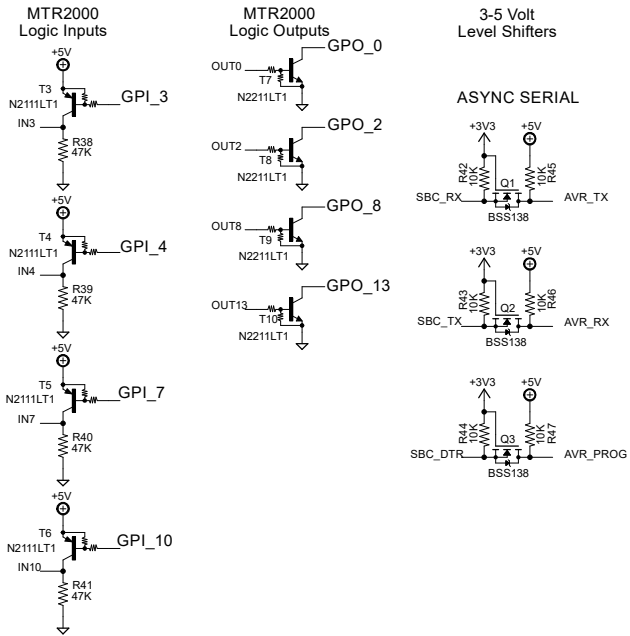

ANALOG CONDITIONING

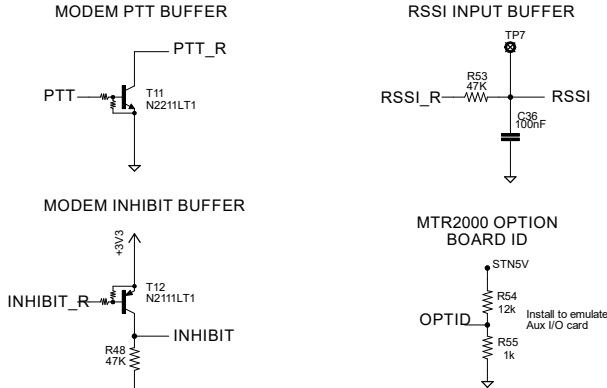

I/O INDICATORS

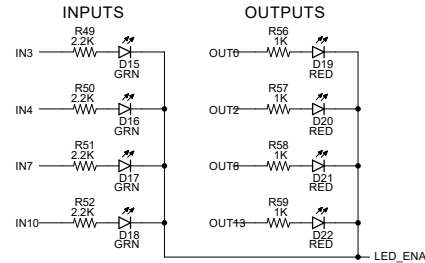

MODEM PROGRAMMING

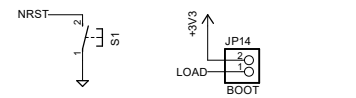

Repeater-Builder		M. Scott Zimmerman N3XCC	
TITLE: STM32_DVM_MTR2K v3			
Document Number:			REV: A
Date: 7/29/2020 1:03:56 PM			Sheet: 2/2